



Site Servicing and Stormwater  
Management Brief – Mooney's Bay -  
729 Ridgewood Avenue, Ottawa, ON

File: 160410536/83

June 30, 2022

Prepared for:

Brigil Homes

Prepared by:

Stantec Consulting Ltd.

<b>Revision</b>	<b>Description</b>	<b>Author</b>		<b>Quality Check</b>	
0	1 <sup>st</sup> submission	A. Paerez	09/06/2021	K. Kilborn	09/06/2021
1	2 <sup>nd</sup> submission	D. Thiffault	29/06/2022	K. Kilborn	30/06/2022



**SITE SERVICING AND STORMWATER MANAGEMENT BRIEF – MOONEY’S BAY - 729 RIDGEWOOD AVENUE,  
OTTAWA, ON**

This document entitled Site Servicing and Stormwater Management Brief – Mooney's Bay - 729 Ridgewood Avenue, Ottawa, ON was prepared by Stantec Consulting Ltd. ("Stantec") for the account of Brigil Homes (the "Client"). Any reliance on this document by any third party is strictly prohibited. The material in it reflects Stantec's professional judgment in light of the scope, schedule and other limitations stated in the document and in the contract between Stantec and the Client. The opinions in the document are based on conditions and information existing at the time the document was published and do not take into account any subsequent changes. In preparing the document, Stantec did not verify information supplied to it by others. Any use which a third party makes of this document is the responsibility of such third party. Such third party agrees that Stantec shall not be responsible for costs or damages of any kind, if any, suffered by it or any other third party as a result of decisions made or actions taken based on this document.



Prepared by \_\_\_\_\_  
(signature)

**Dustin Thiffault, P. Eng.**



Reviewed by \_\_\_\_\_  
(signature)

**Kris Kilborn**



## Table of Contents

<b>1.0</b>	<b>INTRODUCTION AND OBJECTIVE</b> .....	<b>1.1</b>
1.1	OBJECTIVE.....	1.2
<b>2.0</b>	<b>REFERENCES</b> .....	<b>2.1</b>
<b>3.0</b>	<b>WATER DISTRIBUTION</b> .....	<b>3.1</b>
<b>4.0</b>	<b>SANITARY SEWER</b> .....	<b>4.1</b>
4.1	SANITARY SEWER DESIGN CRITERIA.....	4.2
<b>5.0</b>	<b>STORMWATER MANAGEMENT</b> .....	<b>5.1</b>
5.1	OBJECTIVES .....	5.1
5.2	EXISTING CONDITIONS .....	5.1
5.3	SWM CRITERIA AND CONSTRAINTS .....	5.1
5.4	STORMWATER MANAGEMENT DESIGN.....	5.2
5.4.1	Design Methodology .....	5.2
5.4.2	Water Quantity Control .....	5.3
5.4.3	Allowable Release Rate .....	5.3
5.4.4	Storage Requirements .....	5.3
5.4.5	Uncontrolled Area.....	5.4
5.4.6	Results .....	5.5
5.4.7	Water Quality Control.....	5.5
<b>6.0</b>	<b>GRADING AND DRAINAGE</b> .....	<b>6.1</b>
<b>7.0</b>	<b>UTILITIES</b> .....	<b>7.1</b>
<b>8.0</b>	<b>EROSION CONTROL DURING CONSTRUCTION</b> .....	<b>8.1</b>
<b>9.0</b>	<b>GEOTECHNICAL INVESTIGATION AND ESA</b> .....	<b>9.1</b>
9.1	GEOTECHNICAL INVESTIGATION.....	9.1
9.2	PHASE ONE ENVIRONMENTAL SITE ASSESSMENT.....	9.3
9.3	PHASE TWO ENVIRONMENTAL SITE ASSESSMENT .....	9.4
<b>10.0</b>	<b>CONCLUSIONS</b> .....	<b>10.1</b>
10.1	WATER SERVICING .....	10.1
10.2	SANITARY SERVICING .....	10.1
10.3	STORMWATER SERVICING .....	10.1
10.4	GRADING .....	10.1
10.5	UTILITIES .....	10.2
10.6	APPROVAL / PERMITS .....	10.2

### LIST OF TABLES

Table 1: Estimated Water Demands .....	3.1
--	-----



Table 2: Boundary Conditions .....	3.2
Table 3: Estimated Wastewater Peak Flow .....	4.1
Table 4: Target Release Rate.....	5.3
Table 5 – 2-Year Summary of Roof Controls.....	5.3
Table 6 – 100-Year Summary of Roof Controls.....	5.4
Table 7: Peak Controlled (Cistern) 2-Year Release Rate .....	5.4
Table 8: Peak Controlled (Cistern) 100-Year Release Rate .....	5.4
Table 9: Peak Uncontrolled (Non-tributary) 2-Year Release Rate .....	5.4
Table 10: Peak Uncontrolled (Non-tributary) 100-Year Release Rate .....	5.4
Table 11: Estimated Discharge from Site (2-Year) .....	5.5
Table 12: Estimated Discharge from Site (100-Year) .....	5.5
Table 13: Recommended Parking Structure – Parking Areas .....	9.1
Table 14: Recommended Parking Structure – Local Roadways, Access Lanes and Heavy Vehicle Parking .....	9.2

**LIST OF FIGURES**

Figure 1: Site Location .....	1.1
-------------------------------	-----

**LIST OF APPENDICES**

<b>APPENDIX A</b>	<b>WATER CALCULATIONS.....</b>	<b>A.1</b>
<b>APPENDIX B</b>	<b>PROPOSED SITE PLAN .....</b>	<b>B.1</b>
<b>APPENDIX C</b>	<b>SANITARY SEWER CALCULATIONS.....</b>	<b>C.1</b>
<b>APPENDIX D</b>	<b>STORMWATER MANAGEMENT CALCULATIONS.....</b>	<b>D.1</b>
<b>APPENDIX E</b>	<b>GEOTECHNICAL REPORT AND ENVIRONMENTAL SITE ASSESSMENT .....</b>	<b>E.1</b>
<b>APPENDIX F</b>	<b>CITY OF OTTAWA SERVICING STUDY CHECKLIST .....</b>	<b>F.1</b>
<b>APPENDIX G</b>	<b>BACKGROUND CORRESPONDENCE .....</b>	<b>G.1</b>
<b>APPENDIX H</b>	<b>DRAWINGS.....</b>	<b>H.1</b>



# SITE SERVICING AND STORMWATER MANAGEMENT BRIEF – MOONEY’S BAY - 729 RIDGEWOOD AVENUE, OTTAWA, ON

## Introduction and Objective

### 1.0 INTRODUCTION AND OBJECTIVE

Stantec Consulting Ltd. has been retained by Brigil Homes to prepare the following site servicing and stormwater management (SWM) brief to satisfy the City of Ottawa Site Plan Control Application process. The site is located at 729 Ridgewood Avenue, generally surrounded by residential and institutional developments in the city of Ottawa (see **Figure 1** below).

The site proposed for re-development measures 1.33 ha. The proposed re-development area was previously occupied by a commercial site and associated paved parking areas. The proposed development consists of four (4) multi-storey buildings with two consisting of commercial land uses on the ground floor and apartment buildings on the floors above and remaining ground floor space. The four buildings will surround a common courtyard area, surface parking areas and an access road and will provide a total of 446 residential units, 721 m<sup>2</sup> of commercial area, two levels of underground parking and associated access and servicing infrastructure. The proposed site plan has been included in **Appendix B**.

**Figure 1: Site Location**



# **SITE SERVICING AND STORMWATER MANAGEMENT BRIEF – MOONEY’S BAY - 729 RIDGEWOOD AVENUE, OTTAWA, ON**

## Introduction and Objective

### **1.1 OBJECTIVE**

This site servicing and SWM brief has been prepared to present a servicing scheme that is free of conflicts and which utilizes the existing infrastructure as obtained from available as-built drawings and in consultation with City of Ottawa staff. Infrastructure requirements for water supply, sanitary and storm sewer services are presented in this report.

Criteria and constraints provided by the City of Ottawa have been used as a basis for the conceptual servicing design of the proposed development. Specific elements and potential development constraints to be addressed are as follows:

- Prepare a grading plan in accordance with the proposed site plan and existing grades.
- Storm Sewer Servicing
  - Define major and minor conveyance systems in conjunction with the proposed grading plan
  - Determine the stormwater management storage requirements to meet the allowable release rate for the site
  - Coordinate with mechanical engineer to convey drainage from roof tops, amenity areas, and private terrace areas to the internal cistern and discharge to the proposed storm service lateral at the allowable release rate.
  - Define and size the proposed storm service lateral that will be connected to the existing 300 mm diameter storm sewer on Ridgewood Avenue.
- Wastewater Servicing
  - Define and size the sanitary service lateral which will be connected to the existing 225 mm diameter sanitary sewer on Ridgewood Avenue.
- Water Servicing
  - Estimate water demands to characterize the proposed feed for the development which will be serviced from the existing 305 mm diameter watermain on Ridgewood Avenue.
  - Watermain servicing for the development is to be able to provide average day and maximum day (including peak hour) demands (i.e., non-emergency conditions) at pressures within the acceptable range of 50 to 70 psi (350 to 480 kPa).
  - Under fire flow (emergency) conditions, the water distribution system is to maintain a minimum pressure greater than 20 psi (140 kPa).

The accompanying drawings included in the back of this report illustrate the proposed internal servicing scheme for the site.



# SITE SERVICING AND STORMWATER MANAGEMENT BRIEF – MOONEY’S BAY - 729 RIDGEWOOD AVENUE, OTTAWA, ON

References

## 2.0 REFERENCES

The following background studies have been referenced during the preliminary servicing design of the proposed site:

- *City of Ottawa Design Guidelines – Water Distribution*, City of Ottawa, July 2010
- *City of Ottawa Sewer Design Guidelines*, City of Ottawa, October 2012
- *Technical Bulletin ISDTB-2014-01*, City of Ottawa, February 2014
- *Technical Bulletin ISTB-2018-01*, City of Ottawa, March 21, 2018
- *Technical Bulletin ISTB-2018-02*, City of Ottawa, March 21, 2018
- *Technical Bulletin ISTB-2018-03*, City of Ottawa, March 21, 2018
- *Technical Bulletin PI EDTB -2016-01*, City of Ottawa, September 6, 2016
- *Geotechnical Investigation Proposed Multi-Storey Building 729 Ridgewood Avenue – Ottawa*, Paterson Group, September 15, 2020
- *Sawmill Creek Subwatershed Study Update*, CH2MHILL, May 2003
- *Phase One Environmental Site Assessment – 729 Ridgewood Avenue, Ottawa, Ontario*, Lopers and Associates, July 27, 2020
- *Phase Two Environmental Site Assessment – 729 Ridgewood Avenue, Ottawa, Ontario*, Lopers and Associates, August 14, 2020



### **3.0 WATER DISTRIBUTION**

The proposed development is located in Pressure Zone 2W2C of the City of Ottawa's Water Distribution System. The proposed development will be serviced through the existing 305 mm diameter watermain on Ridgewood Avenue as shown on the Site Servicing Plan (see **Drawing SSP-1**).

The proposed development encompasses four residential buildings, one of which being a mixed-use building with retail spaces on the ground floor and residential units on the higher floors, two levels of underground parking, landscaped amenity areas, surface parking areas and an access road. Tower I will consist of a 20-storey residential building with 142 one-bedroom apartments, 41 two-bedroom apartments and 33 three-bedroom apartments. Building II is attached to Tower I and will consist of a 6-storey residential building with 74 one-bedroom apartments and 17 two-bedroom apartments. Building III is a 4-storey residential building with 71 one-bedroom apartments and 14 two-bedroom apartments. Building IV is also a 4-storey residential building with commercial uses on the first floor and with 39 one-bedroom apartments, 12 two-bedroom apartments, and 3 three-bedroom apartments. The proposed site plan is included in **Appendix B**.

Water demands were calculated using the City of Ottawa Water Distribution Guidelines (July 2010) to determine the typical operating pressures to be expected at the proposed development (see detailed calculations in **Appendix A**). A daily rate of 280 L/cap/day has been applied for the population of the proposed site. The average daily (AVDY) residential demand was estimated for an occupancy of 1.4 persons per unit for a one-bedroom apartment, 2.1 persons per unit for a two-bedroom apartment and 3.1 persons per unit for a three-bedroom apartment. Water demands for the proposed retail/commercial space were estimated based on 28,000 L/ha/day. Maximum day (MXDY) demands were determined by multiplying the AVDY demands by a factor of 2.5 for residential areas and by a factor of 1.5 for commercial areas. Peak hourly (PKHR) demands were determined by multiplying the MXDY demands by a factor of 2.2 for residential areas and by a factor of 1.8 for commercial areas. The estimated demands are summarized in **Table 1**.

**Table 1: Estimated Water Demands**

	<b>Population/Area</b>	<b>AVDY (L/s)</b>	<b>MXDY (L/s)</b>	<b>PKHR (L/s)</b>
Residential	744 persons	2.42	6.03	13.27
Commercial	721 m <sup>2</sup>	0.23	0.35	0.63
<b>Total Site:</b>		<b>2.65</b>	<b>6.38</b>	<b>13.90</b>

Required fire flows for the development have been developed under the *Water Supply for Public Fire Protection* guide as produced by the Fire Underwriters Survey (FUS). Calculation sheets





## SITE SERVICING AND STORMWATER MANAGEMENT BRIEF – MOONEY’S BAY - 729 RIDGEWOOD AVENUE, OTTAWA, ON

### Water Distribution

have been prepared considering all buildings on-site to be equipped with sprinklers designed per NFPA 13. Tower I and Building II were assessed as a single building of non-combustible construction with protected vertical openings as described in the FUS guidelines. Buildings III and IV were assessed as combustible relating to Type IV-B mass timber construction based on requirements for structural members including floor assemblies and interior bearing walls to have fire resistance ratings no less than 1 hr. Calculation sheets are included as part of **Appendix A**. The minimum required fire flow for this development has been determined to be 100 L/s (6,000L/min).

**Table 2** outlines the boundary conditions provided by the City of Ottawa on April 27, 2021.

**Table 2: Boundary Conditions**

	<b>Connection to Ridgewood Av.</b>
<b>Min. HGL (m)</b>	123.7
<b>Max. HGL (m)</b>	131.9
<b>Max. Day + Fire Flow (117 L/s)</b>	125.6

1. Fire flow requirements for the proposed site have been revised to 100 L/s and as such, are conservative for the subject development.

The desired normal operating objective pressure range as per the City of Ottawa 2010 Water Distribution Design Guidelines is 350 kPa (50 psi) to 480kPa (70 psi) and no less than 275kPa (40 psi) at ground elevation. Furthermore, the maximum pressure at any point in the water distribution should not exceed 100 psi as per the Ontario Building/Plumbing Code; pressure reducing measures are required to service areas where pressures greater than 552kPa (80 psi) are anticipated.

The ground elevation along Ridgewood Avenue where the proposed building services are to be connected is approximately 82.43 m. With respect to the peak hour flow conditions, the resulting boundary condition HGL of 123.7 m corresponds to a peak hour pressure of 407 kPa (59 psi) at ground elevation. Since the proposed development consists of 4-storey, 6-storey and 20-storey towers, and an additional 34 kPa (5 psi) for every additional storey over two storeys is required to account for the change in elevation head and additional head loss, it is expected that booster pumps will be required for the 6-storey and 15-storey towers to maintain an acceptable level of service on the higher floors.

A maximum pressure check can be conducted using the buildings' lowest finished floor elevation (~83.45 m for Tower IV) and the maximum boundary condition HGL of 131.9 m. This results in a pressure of 476 kPa (69 psi). This value is below the limit of 80 psi for which pressure reducing valves would be required.

Boundary conditions provided by the City confirm that a flow rate of 7,000 L/min (117 L/s) would have a residual pressure of 421 kPa (61 psi) on Ridgewood Avenue based on anticipated ground elevation of 82.43m. As such, the required fire flow rate of 6,000 L/min is achievable



## **SITE SERVICING AND STORMWATER MANAGEMENT BRIEF – MOONEY’S BAY - 729 RIDGEWOOD AVENUE, OTTAWA, ON**

### Water Distribution

within the watermain at the connection location while maintaining a residual pressure above the minimum allowable pressure of 138kPa (20 psi).

There are two hydrants along Ridgewood Avenue in close proximity to the site: one hydrant approximately 108 m west of the site and a second hydrant approximately 65 m east of the site. It is proposed to install a hydrant on-site as shown on **Drawing SSP-1** to ensure an available hydrant is within 45m of the building fire department connection per OBC requirements.

In conclusion, based on the boundary conditions available, the 305 mm diameter watermain on Ridgewood Avenue provides adequate fire flow capacity and water volumes to meet domestic demands for the proposed development. In order to meet the City water supply objective that limits a single feed to 50 m<sup>3</sup>/d during basic day demands, two connections are required to service the proposed development. The service connections will be capable of providing anticipated demands at acceptable pressures to the lower storeys but will require booster pumps to maintain minimum required pressures for the higher floors of the proposed 6-storey and 20-storey buildings.



Sanitary Sewer

## 4.0 SANITARY SEWER

As illustrated on **Drawing SSP-1**, sanitary servicing for the proposed development will be provided through a proposed 200 mm diameter service lateral connecting to the existing 225 mm diameter sanitary sewer running east on Ridgewood Avenue.

The proposed 1.33 ha re-development area will consist of four (4) multi-storey buildings with two levels of underground parking, a common courtyard area, surface parking areas and an access road. The proposed buildings will include retail space within the ground floor of two buildings (721 m<sup>2</sup>), 326 one-bedroom apartments, 84 two-bedroom apartments, and 36 three-bedroom apartments. The anticipated wastewater peak flows generated from the proposed development is summarized in **Table 3** below, while a sanitary sewer design sheet is included in **Appendix C**.

**Table 3: Estimated Wastewater Peak Flow**

Residential/Commercial Peak Flows					Infiltration Flow (L/s)	Total Peak Flow (L/s)
	# of Units/Area	Population	Peak Factor	Peak Flow (L/s)		
Residential	446 units	744	3.88	9.36	0.44	9.83
Commercial	0.072 ha	N/A	1.50	0.04		

1. Average residential flow based on 280 L/p/day
2. Peak factor for residential units calculated using Harmon's formula
3. Apartment population estimated based on 1.4 persons/unit for one-bedroom apartments, 2.1 persons/unit for two-bedroom apartments and 3.1 persons/unit for three-bedroom apartments
4. Commercial peak flows estimated based on 28,000 L/ha/day
5. Infiltration flow based on 0.33 L/s/ha.

The proposed sewage peak flows were initially provided to City of Ottawa staff to conduct a capacity analysis of the sanitary sewer system in the vicinity of the site with the addition of 8.72L/s from the current development. Confirmation was received that there are no concerns with respect to adding the proposed sanitary peak flows to the existing sewers on Ridgewood Avenue (see correspondence in **Appendix C**). It is assumed that the minor increase to 9.83L/s from the 8.72L/s value initially noted will have negligible impact on the downstream system.

Detailed sanitary sewage calculations are included in **Appendix C**. A backflow preventer will be required for the proposed building in accordance with the Ottawa Sewer Design Guidelines and will be coordinated with building mechanical engineers.

All underground parking drains should be connected to the building's internal plumbing. A sump pump will be required to drain the underground parking levels to the existing sanitary sewer on Ridgewood Avenue.



Sanitary Sewer

## **4.1 SANITARY SEWER DESIGN CRITERIA**

As outlined in the City of Ottawa Sewer Design Guidelines and the MECP’s Design Guidelines for Sewage Works, the following criteria were used to calculate estimated wastewater flow rates and to size the sanitary sewer lateral:

- Minimum Velocity – 0.6 m/s (0.8 m/s for upstream sections)
- Maximum Velocity – 3.0 m/s
- Manning roughness coefficient for all smooth wall pipes – 0.013
- 1.4 persons/one-bedroom apartment
- 2.1 persons/two-bedroom apartment
- 3.1 persons/three-bedroom apartment
- 28,000 L/ha/day for commercial areas
- Harmon’s Formula for Residential Peak Factor – Max = 4.0
- Commercial Peak Factor of 1.5
- Extraneous Flow Allowance – 0.33 L/s/ha (conservative value)
- Manhole Spacing – 120 m
- Minimum Cover – 2.5 m



## **5.0 STORMWATER MANAGEMENT**

### **5.1 OBJECTIVES**

The objective of this stormwater management plan is to determine the measures necessary to control the quantity of stormwater released from the proposed development to the required levels and to provide sufficient detail for approval and construction.

### **5.2 EXISTING CONDITIONS**

The proposed re-development area was previously occupied by two slab on grade commercial buildings, associated access roads and paved parking areas. A former mechanics garage which has been recently demolished was located on the east portion of the site. The previous site was serviced through the existing 300 mm diameter storm sewer on Ridgewood Avenue (see **Drawing EX-1**).

City of Ottawa staff recommended stormwater management peak flows from the proposed site be restricted to the 2-year storm with a runoff coefficient based on the Sawmill Creek Subwatershed Study (CH2MHILL, May 2003) and a minimum time of concentration (T<sub>c</sub>) of 10 minutes (see pre-consultation meeting notes in **Appendix G**).

The Sawmill Creek Subwatershed Study (CH2MHILL, May 2003) assessed the hydrology and fluvial geomorphology of the creek under ultimate development conditions which considered the proposed site as a commercial site per the development conditions at the time of the report and as such, target peak outflows from the proposed development have been estimated using a runoff coefficient (C) of 0.80. The time of concentration of the existing development was assessed assuming a storm sewer network as per the storm sewer design sheet included in **Appendix D**, which resulted in a T<sub>c</sub> of 12.38 minutes.

The proposed 729 Ridgewood Avenue re-development encompasses approximately 1.33 ha of land which, assuming a time of concentration (T<sub>c</sub>) of 12.38 minutes, results in an allowable peak outflow of  $Q = 2.78 \times C \times I \times A = 2.78 \times 0.80 \times 68.73 \times 1.33 = \mathbf{203.3 \text{ L/s}}$ .

### **5.3 SWM CRITERIA AND CONSTRAINTS**

The stormwater management criteria for the proposed site are based on City of Ottawa Sewer Design Guidelines (2012) and on consultation with City of Ottawa Staff. The following summarizes the criteria used in the preparation of this stormwater management plan:

- Control post development peak flows up to the 100-year storm to the 2-year runoff with a runoff coefficient (C) of 0.80 which corresponds to **203.3 L/s**.



# SITE SERVICING AND STORMWATER MANAGEMENT BRIEF – MOONEY’S BAY - 729 RIDGEWOOD AVENUE, OTTAWA, ON

## Stormwater Management

- Size storm sewers using an inlet time of concentration ( $T_c$ ) of 10 minutes
- Post-development runoff coefficient ( $C$ ) value based on proposed impervious areas as per site plan drawing (see **Appendix D**)
- Provide ‘Enhanced’ level of quality control (i.e., 80% TSS removal)

## 5.4 STORMWATER MANAGEMENT DESIGN

The proposed 1.33 ha re-development area consists of four (4) multi-storey buildings with two levels of underground parking, a common courtyard area, surface parking areas, and associated access and servicing infrastructure. The imperviousness of the proposed site is 63% ( $C = 0.64$ ).

The SWM strategy for the site is to use roof storage wherever possible and to provide a cistern in the underground parking to attenuate peak flows in the downstream system to the allowable release rate of 203.3 L/s. The proposed buildings will capture storm drainage through a combination of uncontrolled roof drains (Building II), controlled roof drains (remaining buildings), a trench drain that will capture runoff from the roundabout, amenity area drains and a trench drain at the end of the parking ramp that will direct peak flows to the cistern located in the underground parking levels for attenuation. Controlled peak flows from the cistern will be pumped from Building 4, and ultimately discharged into the existing 300 mm diameter storm sewer on Ridgewood Avenue. Coordination with the mechanical consultant is on-going to size the internal plumbing system and the underground cistern.

The proposed site plan, drainage areas and proposed storm sewer infrastructure are shown on **Drawing SD-1**.

### 5.4.1 Design Methodology

The intent of the stormwater management plan presented herein is to mitigate any negative impact that the proposed development could have on the existing drainage and storm sewer infrastructure, while providing adequate capacity to service the proposed buildings, parking and access areas. The proposed stormwater management plan is designed to detain runoff on the roofs of buildings and in an underground cistern to ensure that peak flows after construction from the proposed re-development area will not exceed the target release rate for the site.

A portion of the site could not be graded to enter the building’s internal plumbing system and as such it will sheet drain uncontrolled to the Ridgewood Avenue ROW. Runoff from this uncontrolled area is included in the overall site discharge calculations.



Stormwater Management

### 5.4.2 Water Quantity Control

The Modified Rational Method was used to assess the quantity and volume of runoff generated during post development conditions. The site was subdivided into subcatchments (subareas) tributary to storm sewer inlets, as defined by the location of inlet grates and used in the storm sewer design (see **Appendix D**). A summary of subareas and runoff coefficients is provided in **Appendix D**, and **Drawing SD-1** indicates the stormwater management subcatchments.

### 5.4.3 Allowable Release Rate

Site discharge rates up to the 100-year storm event are to be restricted to the 2-year storm event with a runoff coefficient ('C' value of 0.80) as outlined below in **Table 4**.

**Table 4: Target Release Rate**

Rational Method 'C'	Area (ha)	Time of Concentration (min)	Q <sub>Target</sub> (L/s)
0.80	1.33	12.38	203.3

### 5.4.4 Storage Requirements

The site requires quantity control measures to meet the stormwater release criteria. Therefore, it is proposed to use roof storage and underground storage in a cistern located in the underground parking. Stormwater management calculations are provided in **Appendix D**.

#### 5.4.4.1 Roof Storage

The roof of the proposed Building 2 will consist of a partial green roof with public amenity areas and as such it has been assumed that any roof drains will maintain an open flow control setting. The following calculations assume the roofs of on-site buildings will be equipped with standard Watts Model R110 Accuflow Single Notch Roof Drains and that 80% of the roof areas are usable. **Table 5** and **Table 6** summarize the 2-year and 100-year roof release rates and storage requirements respectively.

**Table 5 – 2-Year Summary of Roof Controls**

Area ID	# of Drains	Usable Roof Area (m <sup>2</sup> )	Depth (mm)	Discharge (L/s)	Drawdown Time (h)	Storage Volume (m <sup>3</sup> )
ROOF1	4 drains – 50% open	720	96	3.7	0.8	9.6
ROOF2	4 drains – 100% open	1040	74	3.7	0.5	6.3
ROOF3	6 drains – 75% open	1360	98	6.5	0.9	19.0
ROOF4	4 drains – 100% open	1200	100	5.1	1.2	17.9



**Table 6 – 100-Year Summary of Roof Controls**

Area ID	# of Drains	Usable Roof Area (m <sup>2</sup> )	Depth (mm)	Discharge (L/s)	Drawdown Time (h)	Storage Volume (m <sup>3</sup> )
ROOF1	4 drains – 50% open	720	146	4.9	2.2	33.3
ROOF2	4 drains – 100% open	1040	117	5.9	1.5	25.2
ROOF3	6 drains – 75% open	1360	146	9.2	2.3	63.1
ROOF4	4 drains – 100% open	1200	148	7.5	2.8	57.6

#### 5.4.4.2 Subsurface Storage

It is proposed to detain stormwater within a 50 m<sup>3</sup> cistern below grade with a maximum controlled release rate of 166.2 L/s to the gravity service provided. The modified rational method was used to determine the peak volume requirement for the cistern. Site drainage areas are captured into the building plumbing directed to the cistern for additional control.

**Table 7** and **Table 8** summarize the flow rates and storage from the cistern for the 2 and 100-year events, respectively.

**Table 7: Peak Controlled (Cistern) 2-Year Release Rate**

Area ID	Area (ha)	Runoff 'C'	Q <sub>release</sub> (L/s)	V <sub>stored</sub> (m <sup>3</sup> )
ROOF1-4, TANK1-6	1.20	0.66	94.1	0.0

**Table 8: Peak Controlled (Cistern) 100-Year Release Rate**

Area ID	Area (ha)	Runoff 'C'	Q <sub>release</sub> (L/s)	V <sub>stored</sub> (m <sup>3</sup> )
ROOF1-4, TANK1-6	1.20	0.82	166.2	47.2

#### 5.4.5 Uncontrolled Area

A portion of the site around the buildings (see **Drawing SD-1**) could not be graded to enter the building's internal plumbing system and as such it will sheet drain uncontrolled. **Table 9** and **Table 10** summarize the 2 and 100-year uncontrolled release rates from the proposed development.

**Table 9: Peak Uncontrolled (Non-tributary) 2-Year Release Rate**

Area ID	Area (ha)	Runoff 'C'	T <sub>c</sub> (min)	Q <sub>release</sub> (L/s)
UNC-1	0.13	0.46	10	12.8

**Table 10: Peak Uncontrolled (Non-tributary) 100-Year Release Rate**

Area ID	Area (ha)	Runoff 'C'	T <sub>c</sub> (min)	Q <sub>release</sub> (L/s)
UNC-1	0.13	0.58	10	37.1





Stormwater Management

**5.4.6 Results**

**Table 11** and **Table 12** demonstrate that the proposed stormwater management plan provides adequate attenuation storage to meet the target peak outflow for the site.

**Table 11: Estimated Discharge from Site (2-Year)**

Area Type	Q <sub>release</sub> (L/s)	Target (L/s)
Controlled Cistern Discharge	94.1	<b>203.3</b>
Uncontrolled Sheet Flow	12.8	
<b>Total</b>	<b>106.8</b>	

**Table 12: Estimated Discharge from Site (100-Year)**

Area Type	Q <sub>release</sub> (L/s)	Target (L/s)
Controlled Cistern Discharge	166.2	<b>203.3</b>
Uncontrolled Sheet Flow	37.1	
<b>Total</b>	<b>203.3</b>	

**5.4.7 Water Quality Control**

The storm sewers on Ridgewood Avenue ultimately discharge into Sawmill Creek less than 1 km downstream of the proposed development. The Rideau Valley Conservation Authority (RVCA) that confirmed through correspondence that given that the proposed development consists of more than 6 surface parking spaces, onsite water quality treatment will be required to provide 'Enhanced' level of quality control, which is equivalent to 80% Total Suspended Solids (TSS) removal.

A Stormceptor oil-grit separator has been sized to specify a unit capable of providing the required TSS removal. Assessment of a drainage area of 1.20 ha (i.e., surface parking, roof, and access areas) with an imperviousness of 66% results in the requirement to install a Stormceptor EF06 to provide the required long term 80% TSS removal. It should be noted that the Stormceptor unit has been provided as an example and that an approved equivalent unit can be used during construction subject to approval. Stormceptor sizing information has been provided in **Appendix D**.



Grading and Drainage

## **6.0 GRADING AND DRAINAGE**

The proposed re-development site measures approximately 1.33 ha in area. A detailed grading plan (see **Drawing GP-1**) has been provided to satisfy stormwater management requirements and coordinated to accommodate architectural constraints.

The subject site maintains emergency overland flow routes to the back and to Ridgewood Avenue as depicted on **Drawings GP-1** and **SD-1**.



Utilities

## **7.0 UTILITIES**

All utilities (Hydro Ottawa, Bell Canada, Rogers Ottawa, and Enbridge Gas) have existing plants in the area. The site will be serviced through connection to these existing services. Detailed design of the required utility services will be further investigated as part of the composite utility planning process following design circulation.



Erosion Control During Construction

## **8.0 EROSION CONTROL DURING CONSTRUCTION**

Erosion and sediment controls must be in place during construction. The following recommendations to the contractor will be included in contract documents.

1. Implement best management practices to provide appropriate protection of the proposed drainage system and the receiving water course(s).
2. Limit extent of exposed soils at any given time.
3. Re-vegetate exposed areas as soon as possible.
4. Minimize the area to be cleared and grubbed.
5. Protect exposed slopes with plastic or synthetic mulches.
6. Provide sediment traps and basins during dewatering.
7. Install sediment traps (such as SiltSack® by Terrafix) between catch basins and frames.
8. Plan construction at proper time to avoid flooding.
9. Installation of a mud matt to prevent mud and debris from being transported off site.
10. Installation of a silt fence to prevent sediment runoff.

The contractor will, at every rainfall, complete inspections and guarantee proper performance. The inspection is to include:

1. Verification that water is not flowing under silt barriers.
2. Clean and change silt traps at catch basins.

Refer to **Drawing EC/DS-1** for the proposed location of silt fences, and other erosion control structures.



Geotechnical Investigation and ESA

## **9.0 GEOTECHNICAL INVESTIGATION AND ESA**

### **9.1 GEOTECHNICAL INVESTIGATION**

A geotechnical report for the site was prepared by Paterson Group in September 2020 (see **Appendix E**). As stated in the geotechnical report, the subsurface profile across the site generally consists of asphaltic concrete overlying a fill layer consisting of crushed stone and silty sand. The fill material is underlain by a stiff to hard layer of brown silty clay with sand seams. Glacial till was encountered below the above noted layers consisting of a compact to a very dense silty sand with clay, gravel, cobbles, and boulders. Seams of coarse sand were encountered in the glacial till layer at some test hole locations

Bedrock was cored at one borehole location to confirm refusal. Limestone bedrock was encountered at a depth of 9.7 m below the existing ground surface at BH6. Refusal was encountered in the other boreholes between a depth of 4.8 to 8.7 m. It should be noted that boulders are to be expected.

Groundwater levels were measured in July 2020 and were found to range between 1.9 m and 4.7 m below ground surface elevation. Long-term groundwater levels can also be determined based on observations of the recovered soil samples, such as moisture levels, colouring and consistency. Based on these observations, the long-term groundwater level is expected at a 5 to 6 m depth.

Bedrock removal can be accomplished by hoe ramming where only small quantity of the bedrock needs to be removed. Sound bedrock may be removed by line drilling and controlled blasting and/or hoe ramming.

Prior to considering blasting operations, the blasting effects on the existing services, buildings and other structures should be addressed. A pre-blast or pre-construction survey of the existing structures located in proximity of the blasting operations should be completed prior to commencing site activities. The extent of the survey should be determined by the blasting consultant and should be sufficient to respond to any inquiries/claims related to the blasting operations.

For design purposes, the flexible pavement structure presented in the following tables could be used for the design of car only parking areas in the lower level of the parking garage.

**Table 13: Recommended Parking Structure – Parking Areas**

<b>Thickness (mm)</b>	<b>Material Description</b>
50	Wear Course - HL 3 or Superpave 12.5 Asphaltic Concrete



**SITE SERVICING AND STORMWATER MANAGEMENT BRIEF – MOONEY’S BAY - 729 RIDGEWOOD AVENUE, OTTAWA, ON**

Geotechnical Investigation and ESA

Thickness (mm)	Material Description
150	BASE - OPSS Granular A Crushed Stone
300	SUBBASE - OPSS Granular B Type II
SUBGRADE - Either fill, in situ silty clay or sand or crushed stone material placed over in situ soil.	

**Table 14: Recommended Parking Structure – Local Roadways, Access Lanes and Heavy Vehicle Parking**

Thickness (mm)	Material Description
40	Wear Course - Superpave 12.5 Asphaltic Concrete
50	Binder Course - Superpave 19.0 Asphaltic Concrete
150	BASE - OPSS Granular A Crushed Stone
400	SUBBASE - OPSS Granular B Type II
SUBGRADE - Either fill, in situ silty clay or sand or crushed stone material placed over in situ soil.	

It is expected that the building foundation walls will be placed in close proximity to all the boundaries. It is expected that the foundation wall will be blind poured against a drainage system and waterproofing system fastened against the shoring system.

A waterproofing membrane will be required to lessen the effect of water infiltration for the lower P-2 basement level. The waterproofing membrane can be placed and fastened to the shoring system (soldier pile and timber lagging) and should extend to the bottom of the excavation at the founding level of the raft foundation.

It is recommended that the composite drainage system, such as Delta Drain 6000 or equivalent, extend from the exterior finished grade to the founding elevation (underside of raft slab). The purpose of the composite drainage system is to direct any water infiltration resulting from a breach of the waterproofing membrane to the building sump pit. It is recommended that 150 mm diameter sleeves at 3 m centres be cast in the foundation wall at the raft slab interface to allow the infiltration of water to flow to an interior perimeter underfloor drainage pipe. The perimeter drainage pipe should direct water to sump pit(s) within the lower basement area.

Underfloor drainage will be required to control water infiltration due to groundwater infiltration at the proposed founding elevation. For design purposes, we recommend that 150 mm in diameter perforated pipes be placed along the interior perimeter of the foundation wall and one drainage line within each bay. The spacing of the underfloor drainage system should be confirmed at the time of backfilling the floor completing the excavation when water infiltration can be better assessed.



## **SITE SERVICING AND STORMWATER MANAGEMENT BRIEF – MOONEY’S BAY - 729 RIDGEWOOD AVENUE, OTTAWA, ON**

Geotechnical Investigation and ESA

It is anticipated that groundwater infiltration into the excavations should be controllable using open sumps. The contractor should be prepared to direct water away from all bearing surfaces and subgrades, regardless of the source, to prevent disturbance to the founding medium.

A temporary Ministry of Environment, Conservation and Parks (MECP) Category 3 Permit to Take Water (PTTW) may be required if more than 400,000 L/day are to be pumped during the construction phase. At least 4 to 5 months should be allowed for completion of the application and issuance of the permit by the MECP.

For typical ground or surface water volumes being pumped during the construction phase, typically between 50,000 to 400,000 L/day, it is required to register on the Environmental Activity and Sector Registry (EASR). A minimum of two to four weeks should be allotted for completion of the EASR registration and the Water Taking and Discharge Plan to be prepared by a Qualified Person as stipulated under O.Reg. 63/16. If a project qualifies for a PTTW based upon anticipated conditions, an EASR will not be allowed as a temporary dewatering measure while awaiting the MECP review of the PTTW application.

### **9.2 PHASE ONE ENVIRONMENTAL SITE ASSESSMENT**

Lopers and Associates completed a Phase One Environmental Site Assessment of the existing commercial property in July 2020 (see **Appendix E**).

The Phase One Property was undeveloped prior to the 1950's when initial development was interpreted to have been for residential purposes. A commercial lease was registered at the Phase One Property in 1965 and it is inferred that commercial redevelopment of the Property occurred at this time. Demolition of the former residential building was completed prior to 1991. A retail fuel outlet and automotive service garage were present as part of the original commercial development at the Phase One Property and operated on the southeast portion of the Property until 2002 and 2018, respectively. The automotive garage moved to the south unit of the south commercial building in 2018 and has operated at that location on the Phase One Property since that time.

The presence of a former retail fuel outlet and automotive service garage on the southeast portion of the Phase One Property are a significant potentially contaminating activities (PCAs) which represent areas of potential environmental concern (APECs) for the Property. Given that previous reports were provided which document remnant petroleum hydrocarbon (PHC) and benzene, toluene, ethylbenzene and xylenes (BTEXs) soil contamination and that groundwater quality was not confirmed following the completion of a remediation program, further investigation is warranted. The contaminants of potential concern associated with retail fuelling are generally PHCs and BTEXs, and metals as this was an older facility and lead was historically present in gasoline. Based on historical soil analysis in this area of the Property, polycyclic aromatic hydrocarbons (PAH) and volatile organic compounds (VOCs) are also considered contaminants of potential concern associated with the former automotive garage operations.



## **SITE SERVICING AND STORMWATER MANAGEMENT BRIEF – MOONEY’S BAY - 729 RIDGEWOOD AVENUE, OTTAWA, ON**

Geotechnical Investigation and ESA

The practice of backfilling following demolition activities at the Phase One Property is also a significant PCA which represents an APEC for the Property. Given that no reports were provided with analytical data to support the environmental quality of the backfill used to fill the former residential building footprint on the central-south portion of the Property, this area warrants further investigation. The contaminants of potential concern commonly found in poor environmental quality backfill are PHCs/BTEXs, PAHs and metals.

The presence of an active automotive service garage was observed during the site walk over on the central portion of the Phase One Property at the time of the Site Investigation. Although this garage has only been operating for a short time period (2018 to present), these operations are a PCA which represents an APEC for the Property. Based on the observations at this automotive garage, that contaminants of potential concern are considered to be PHCs and BTEXs.

Three active and/or historical fuel storage tank locations at neighbouring properties in the Phase One Study Area constitute PCAs. The PCAs at neighbouring properties in the Phase One Study Area are located significant distances and at down- or cross-gradient orientations with respect to the Phase One Property and are not considered to represent APECs for the Phase One Property.

Based on the identification of PCAs and APECs at the Phase One Property, it was recommended that a Phase Two Environmental Site Assessment be completed to assess the soil and groundwater quality in the vicinity of the four APECs.

### **9.3 PHASE TWO ENVIRONMENTAL SITE ASSESSMENT**

Lopers & Associates (Lopers) completed a Phase Two Environmental Site Assessment (Phase Two ESA) of the existing commercial property in August 2020.

The scope of work for the Phase Two ESA included drilling seven boreholes at the Phase Two Property. Three of the boreholes were instrumented with groundwater monitoring wells with screens installed in the overburden.

Six soil samples, including one duplicate sample, were submitted for laboratory analysis for a combination of PHCs, BTEXs, volatile organic compounds (VOCs), PAHs, metals and inorganics. One sample was also submitted for toxicity leaching characteristic procedure (TCLP) for waste characterization purposes.

Groundwater sampling was completed of the newly installed monitoring wells and two existing groundwater monitoring wells at the Phase Two Property, which were installed as part of historical investigations. A total of seven groundwater samples, including a duplicate sample and a trip blank, were submitted for laboratory analysis for a combination of PHCs, BTEXs, VOCs, PAHs, metals and inorganics.





## SITE SERVICING AND STORMWATER MANAGEMENT BRIEF – MOONEY’S BAY - 729 RIDGEWOOD AVENUE, OTTAWA, ON

### Geotechnical Investigation and ESA

The applicable sites standard was determined to be the full depth generic site condition standard, in a non-potable groundwater condition, with coarse textured soil, for residential property use, as specified in Table 3 of the MECP Soil, Ground Water and Sediment Standards for Use Under Part XV.1 of the Environmental Protection Act, April 15, 2011.

At APEC #3 (placement of fill of unknown quality) the soil samples BH1-20-SS5 and BH11-20-SS5 (Duplicate of BH1-20-SS5), collected from a depth of approximately 3.1-3.7 m BGS, had reported concentrations of PHC F2 range (909 µg/g and 306 µg/g vs. 98 µg/g), Methylanthalene (7.61 µg/g and 2.26 µg/g vs. 0.99 µg/g) and reported concentrations of vanadium (101 µg/g and 104 µg/g vs. 86 µg/g). These samples also had respective cobalt concentrations of 20.1 µg/g and 22.5 µg/g compared to the site condition standard of 22 µg/g; since the average concentration of cobalt in these samples is less than the site condition standard, the marginal exceedance in the duplicate standard is not considered to exceed the site condition standard.

At APEC #1 (former retail fuel outlet) the soil sample BH3-20-SS6, collected from a depth of approximately 3.8-4.4 m BGS, had reported concentrations of PHC F1 range (117 µg/g vs. 55 µg/g), PHC F2 range (110 µg/g vs. 98 µg/g), benzene (3.02 µg/g vs. 0.21 µg/g), ethylbenzene (59 µg/g vs. 2 µg/g), toluene (73.5 µg/g vs. 2.3 µg/g) and xylenes (276 µg/g vs. 3.1 µg/g). Additionally, PAH exceedances from the same soil sample included Methylanthalene (1.95 µg/g vs. 0.99 µg/g) and Naphthalene (1.69 µg/g vs. 0.6 µg/g).

At APEC #1 (former retail fuel outlet), the groundwater samples BH3-20 and BH13-20 (Duplicate of BH3-20), collected from a screen depth of approximately 2.5-5.5 m BGS, had reported concentrations of PHC F1 range (3,600 µg/g and 3,790 µg/g vs. 750 µg/g), PHC F2 range (52,400 µg/g and 2,260 µg/g vs. 150 µg/g), PHC F3 range (3,940 µg/g vs. 500 µg/g), benzene (19,300 µg/g and 19,700 µg/g vs. 44 µg/g), ethylbenzene (3,800 µg/g and 3,700 µg/g vs. µg/g), toluene (65,200 µg/g and 60,900 µg/g vs. 18,000 µg/g) and xylenes (27,600 µg/g and 26,600 µg/g vs. 4,200 µg/g). Lead was also reported at concentrations of 51.6 µg/g and 54.6 µg/g vs. 25 µg/g.

All of the other soil and groundwater results for the Phase Two Property are in compliance with the applicable site condition standards. The Phase Two Property is not in compliance with the Table 3 site condition standards as of the certification date of June 30, 2020.

An environmental remediation program, including the bulk removal and off-site disposal of soil and groundwater in excess of the site condition standards is recommended for the Phase Two Property. Given the scope and timeline for the proposed redevelopment and the requirements for specialized construction techniques to complete remediation of the Phase Two Property to meet the site condition standards, it is recommended that remediation be completed in conjunction with redevelopment of the property. It should be noted that the proposed redevelopment includes excavation for at least two to three levels of underground parking, which is expected to be sufficient for remediation of the aforementioned environmental contamination at the Phase Two Property.



## **SITE SERVICING AND STORMWATER MANAGEMENT BRIEF – MOONEY’S BAY - 729 RIDGEWOOD AVENUE, OTTAWA, ON**

### Geotechnical Investigation and ESA

Further delineation and confirmation of remediation sampling will be required prior to the completion of an environmental remediation program and confirmation of compliance with the site condition standards; however, these tasks can be completed at the time decommissioning and demolition of existing structures at the Phase Two Property. The submission of a record of site condition would be required in the event of a change of zoning of the Phase Two Property; however, these tasks can be completed at the time decommissioning and demolition of existing structures at the Phase Two Property. The Phase Two ESA could be then updated at that time to show compliance with site condition standards.

Preparation of a soil management plan in accordance with O.Reg. 406/19 will be required as part of management of excess soil generated as part of construction activities. It was recommended that a remedial action plan be prepared to develop a strategy for remediation, including soil and groundwater management, during redevelopment.



Conclusions

## **10.0 CONCLUSIONS**

### **10.1 WATER SERVICING**

The existing 305 mm diameter watermain on Ridgewood Avenue will provide adequate fire flow capacity. In order to meet the City water supply objective that limits a single feed to 50 m<sup>3</sup>/d during basic day demands, two connections are required to service the proposed development. The service connections will be capable of providing anticipated demands at acceptable pressures to the lower storeys but will require booster pumps to maintain minimum required pressures for the higher floors of the proposed 6-storey and 15-storey towers.

### **10.2 SANITARY SERVICING**

The proposed sanitary sewer lateral is sufficiently sized to provide gravity drainage for the site. The proposed site will be serviced by a 200 mm diameter service lateral directing wastewater flows to the existing 225 mm diameter sanitary sewer on Ridgewood Avenue. A backflow preventer will be required for the proposed building in accordance with the Ottawa sewer design guide and will be coordinated with building mechanical engineers.

All underground parking drains should be connected to the building's internal plumbing. A sump pump will be required to drain the underground parking levels to the existing sanitary sewer on Ridgewood Avenue.

### **10.3 STORMWATER SERVICING**

The proposed stormwater management plan is in compliance with the goals specified through consultation with the City of Ottawa, as well as local standards. A combination of roof storage and underground storage within a cistern located in the underground parking will be provided to attenuate post development peak flows. Post development peak flows from the overall site up to the 100-year storm will be restricted to the target release rate. A sump pump will be required to direct flows from the internal building plumbing system to the proposed gravity service connected to the existing 300 mm diameter storm sewer running on Ridgewood Avenue.

### **10.4 GRADING**

Erosion and sediment control measures will be implemented during construction to reduce the impact on existing infrastructure. The subject site will maintain emergency overland flow routes to the back and to Ridgewood Avenue.



## **SITE SERVICING AND STORMWATER MANAGEMENT BRIEF – MOONEY’S BAY - 729 RIDGEWOOD AVENUE, OTTAWA, ON**

Conclusions

### **10.5 UTILITIES**

All utilities (Hydro Ottawa, Bell Canada, Rogers Ottawa, and Enbridge Gas) have existing plants in the subject area. Exact size, location and routing of utilities will be finalized after design circulation.

### **10.6 APPROVAL / PERMITS**

Ministry of the Environment Conservation and Parks (MECP) Environmental Compliance Approvals (ECA) are not expected to be required for the subject site as the site is private and will remain under singular ownership. A Permit to Take Water may be required for pumping requirements for construction of underground parking level. No other approval requirements from other regulatory agencies are anticipated.



# **APPENDICES**

**SITE SERVICING AND STORMWATER MANAGEMENT BRIEF – MOONEY’S BAY - 729  
RIDGEWOOD AVENUE, OTTAWA, ON**

Appendix A Water Calculations

## **Appendix A WATER CALCULATIONS**



**From:** [Rasool, Rubina](#)  
**To:** [Mott, Peter](#)  
**Cc:** [Kilborn, Kris](#)  
**Subject:** RE: 729 Ridgewood Avenue - Boundary Conditions Request  
**Date:** Tuesday, April 27, 2021 3:59:58 PM  
**Attachments:** [729 Ridgewood April 2021.pdf](#)

---

Good afternoon,

The following are boundary conditions, HGL, for hydraulic analysis at 729 Ridgewood Ave (zone 2W2C) assumed to be connected to the 305 mm on Ridgewood Ave (see attached PDF for location).

Both Connections

Minimum HGL = 123.7 m

Maximum HGL = 131.9 m

Max Day + Fire Flow (117 L/s) = 125.6 m

These are for current conditions and are based on computer model simulation.

*Disclaimer: The boundary condition information is based on current operation of the city water distribution system. The computer model simulation is based on the best information available at the time. The operation of the water distribution system can change on a regular basis, resulting in a variation in boundary conditions. The physical properties of watermains deteriorate over time, as such must be assumed in the absence of actual field test data. The variation in physical watermain properties can therefore alter the results of the computer model simulation.*

**Rubina**

-----  
**Rubina Rasool, E.I.T.**

Project Manager

Planning, Infrastructure and Economic Development Department - Services de la planification, de l'infrastructure et du développement économique

Development Review – East Branch

City of Ottawa | Ville d'Ottawa

110 Laurier Avenue West Ottawa, ON | 110, avenue Laurier Ouest. Ottawa (Ontario) K1P 1J1

[rubina.rasool@ottawa.ca](mailto:rubina.rasool@ottawa.ca)

---

**From:** Mott, Peter <Peter.Mott@stantec.com>  
**Sent:** April 13, 2021 9:33 AM  
**To:** Rasool, Rubina <Rubina.Rasool@ottawa.ca>  
**Cc:** Kilborn, Kris <kris.kilborn@stantec.com>  
**Subject:** 729 Ridgewood Avenue - Boundary Conditions Request

**CAUTION: This email originated from an External Sender. Please do not click links or open attachments unless you recognize the source.**

**ATTENTION : Ce courriel provient d'un expéditeur externe. Ne cliquez sur aucun lien et n'ouvrez pas de pièce jointe, excepté si vous connaissez l'expéditeur.**

Hello Ms. Rasool,

I would like to request the hydraulic boundary conditions for the proposed 729 Ridgewood Avenue Development. Please find attached the concept plan, the key map showing the location of the proposed development, domestic water demand calculations, and fire flow calculations.

A summary of the proposed site is provided below:

We anticipate a minimum of two (2) connections to the existing watermain will be required to service the site. The following connections are expected for servicing:

➤Connections to the existing 305 mm (CI) watermain on Ridgewood Avenue.

\*Existing hydrants on Ridgewood Avenue.

**For the purpose of the boundary conditions request, may you please provide us with the boundary conditions for the following servicing options:**

i. Watermain connections to the existing 305 mm (CI) watermain on Ridgewood Avenue; assuming a fire flow requirement of **7,000 L/min** for the site in addition to the domestic water demands provided below.

- The intended land use is a combination of commercial and residential, per the summary provided in the Domestic Demands spreadsheet. (See attached Concept Plan with project stats)
- Estimated fire flow demand per the FUS methodology: 7000 L/min (117 L/s) for the worst-case scenario (Tower I & Building II)
- Domestic water demands for the entire development:
  - **Average day: 172.5 L/min (2.87 L/s)**
  - **Maximum day: 414.3 L/min (6.91 L/s)**
  - **Peak hour: 901.3 L/min (15.02 L/s)**

Thank you for your time and please contact me at your earliest convenience if any additional information or clarification is required.

Best regards,

**Peter Mott** EIT

Engineering Intern, Community Development

Mobile: 613-897-0445

[Peter.Mott@stantec.com](mailto:Peter.Mott@stantec.com)

Stantec

400 - 1331 Clyde Avenue

Ottawa ON K2C 3G4

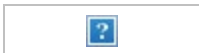

The content of this email is the confidential property of Stantec and should not be copied, modified, retransmitted, or used for any purpose except with Stantec's written authorization. If you are not the intended recipient, please delete all copies and notify us immediately.

,

This e-mail originates from the City of Ottawa e-mail system. Any distribution, use or copying of this e-mail or the information it contains by other than the intended recipient(s) is



unauthorized. Thank you.

Le présent courriel a été expédié par le système de courriels de la Ville d'Ottawa. Toute distribution, utilisation ou reproduction du courriel ou des renseignements qui s'y trouvent par une personne autre que son destinataire prévu est interdite. Je vous remercie de votre collaboration.

,

**Boundary Condition for 729 Ridgewood**

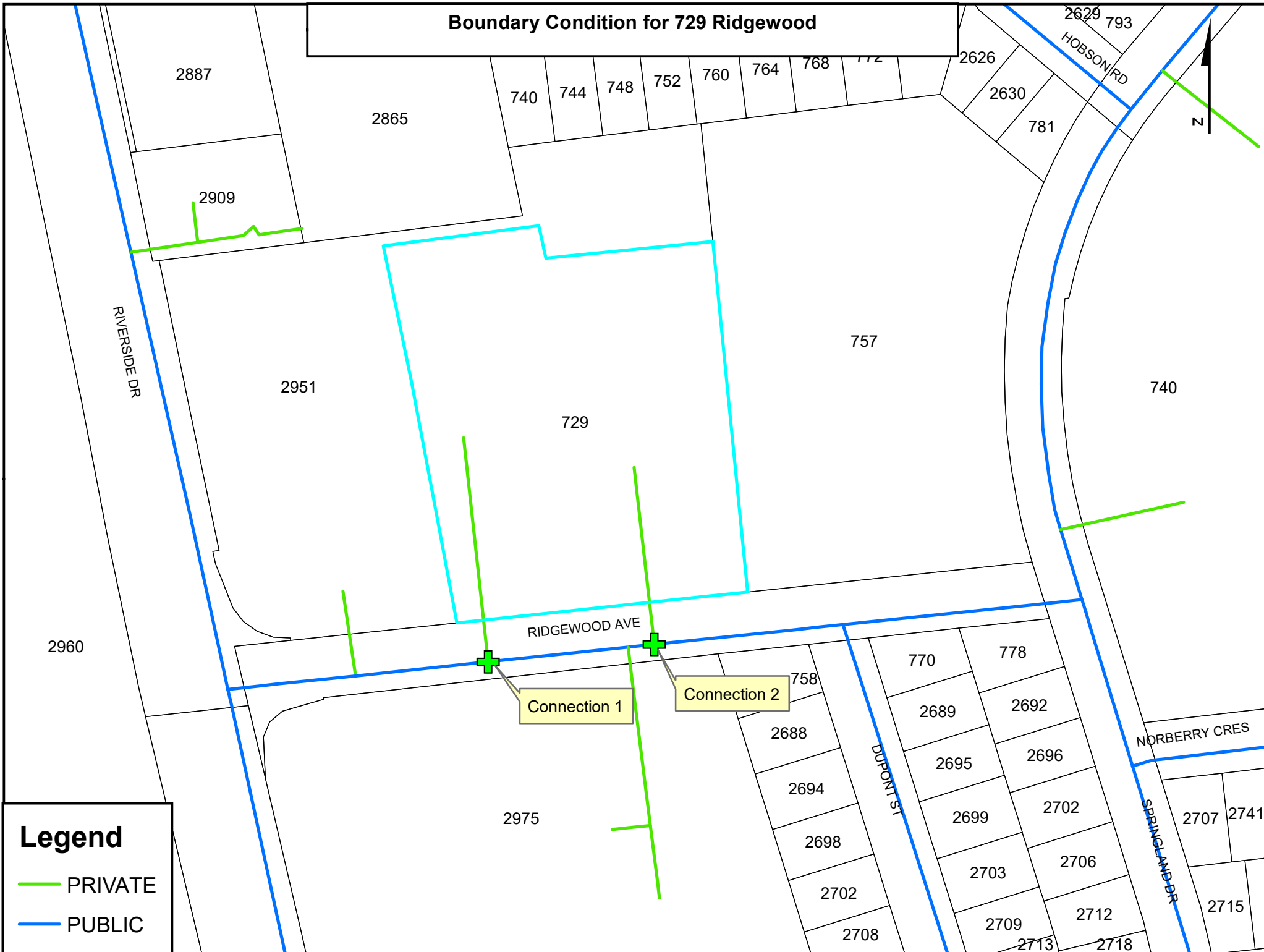

**Legend**

- PRIVATE
- PUBLIC

**729 Ridgewood Avenue (Brigil Development) - Domestic Water Demand Estimates**

Based on conceptual development plans from Neuf Architect(e)s (2022-06-16)  
 Last updated on June 29, 2022

Ottawa Design Guidelines - Water Distribution

Table 4.1 Per Unit Populations		
Studio	1.4	ppu
1 Bedroom	1.4	ppu
2 Bedroom	2.1	ppu
3 Bedroom	3.1	ppu

Development Block/Area ID	Commercial/Amenity Area (m <sup>2</sup> )	Number of Residential Units	Population	Daily Demand Rate (L/cap/day or L/ha/d)	Avg. Day Demand <sup>1,2</sup>		Max. Day Demand <sup>1,2</sup>		Peak Hour Demand <sup>1,2</sup>	
					(L/min)	(L/s)	(L/min)	(L/s)	(L/min)	(L/s)
<b>Tower I (20 Storeys)</b>										
1 Bedroom	-	142	199	280	38.7	0.64	96.6	1.61	212.6	3.54
2 Bedroom	-	41	86	280	16.7	0.28	41.9	0.70	92.1	1.53
3 Bedroom	-	33	102	280	19.9	0.33	49.7	0.83	109.4	1.82
<b>Building II (6 Storeys)</b>										
1 Bedroom	-	74	104	280	20.1	0.34	50.4	0.84	110.8	1.85
2 Bedroom	-	17	36	280	6.9	0.12	17.4	0.29	38.2	0.64
<b>Building III (4 Storeys)</b>										
Studio	-	2	3	280	0.5	0.01	1.4	0.02	3.0	0.05
1 Bedroom	-	69	97	280	18.8	0.31	47.0	0.78	103.3	1.72
2 Bedroom	-	14	29	280	5.7	0.10	14.3	0.24	31.4	0.52
Commercial Area	164	-	-	28000	3.2	0.05	4.8	0.08	8.6	0.14
<b>Building IV (4 Storeys)</b>										
Studio	-	3	4	280	0.8	0.01	2.0	0.03	4.5	0.07
1 Bedroom	-	36	50	280	9.8	0.16	24.5	0.41	53.9	0.90
2 Bedroom	-	12	25	280	4.9	0.1	12.3	0.2	27.0	0.45
3 Bedroom	-	3	9	280	1.8	0.03	4.5	0.08	9.9	0.17
Commercial Area	557	-	-	28000	10.8	0.18	16.2	0.27	29.2	0.49
<b>Total Site :</b>	<b>721</b>	<b>446</b>	<b>744</b>	<b>-</b>	<b>158.8</b>	<b>2.65</b>	<b>382.9</b>	<b>6.38</b>	<b>833.9</b>	<b>13.90</b>

1 Water demand criteria used to estimate peak demand rates for residential areas are as follows:  
 maximum daily demand rate = 2.5 x average day demand rate  
 peak hour demand rate = 2.2 x maximum day demand rate

2 Water demand criteria used to estimate peak demand rates for commercial/amenity/lobby areas are as follows:  
 maximum daily demand rate = 1.5 x average day demand rate  
 peak hour demand rate = 1.8 x maximum day demand rate

3 Population density for all residential units based on an population densities provided in Table 4.1 - Per Unit Populations of the City of Ottawa Water Distribution Design Guidelines (July 2010).



FUS Fire Flow Calculation Sheet - 2020 FUS Guidelines

Stantec Project #: 160401536  
 Project Name: Ridgewood Avenue  
 Date: 6/30/2022

Fire Flow Calculation #: 1  
 Description: Tower I and Building II

Notes: Floorplates at ground level

Step	Task	Notes						Value Used	Req'd Fire Flow (L/min)	
1	Determine Type of Construction	Type II - Noncombustible Construction / Type IV-A - Mass Timber Construction						0.8	-	
2	Determine Effective Floor Area	Sum of Largest Floor + 25% of Two Additional Floors			Vertical Openings Protected?			YES	-	
		2205	2205	2205				3307.5	-	
3	Determine Required Fire Flow	(F = 220 x C x A <sup>1/2</sup> ). Round to nearest 1000 L/min						-	10000	
4	Determine Occupancy Charge	Limited Combustible						-15%	8500	
5	Determine Sprinkler Reduction	Conforms to NFPA 13						-30%	-4250	
		Standard Water Supply						-10%		
		Fully Supervised						-10%		
		% Coverage of Sprinkler System						100%		
6	Determine Increase for Exposures (Max. 75%)	Direction	Exposure Distance (m)	Exposed Length (m)	Exposed Height (Stories)	Length-Height Factor (m x stories)	Construction of Adjacent Wall	Firewall / Sprinklered ?	-	-
		North	> 30	0	0	0-20	Type V	NO	0%	1020
		East	10.1 to 20	22	2	41-60	Type V	NO	12%	
		South	10.1 to 20	23	4	81-100	Type III-IV - Protected Openings	YES	0%	
		West	10.1 to 20	27	2	41-60	Type I-II - Unprotected Openings	YES	0%	
7	Determine Final Required Fire Flow	Total Required Fire Flow in L/min, Rounded to Nearest 1000L/min						5000		
		Total Required Fire Flow in L/s						83.3		
		Required Duration of Fire Flow (hrs)						1.75		
		Required Volume of Fire Flow (m <sup>3</sup> )						525		



FUS Fire Flow Calculation Sheet - 2020 FUS Guidelines

Stantec Project #: 160401536  
 Project Name: Ridgewood Avenue  
 Date: 6/30/2022  
 Fire Flow Calculation #: 2  
 Description: Building III

Notes: 4-Storey Residential, sprinklered with floor assemblies / load bearing walls as 1hr rated assemblies per OBC 3.2.2.52

Step	Task	Notes							Value Used	Req'd Fire Flow (L/min)
1	Determine Type of Construction	Type IV-B Mass Timber Construction							0.9	-
2	Determine Effective Floor Area	Sum of Largest Floor + 25% of Two Additional Floors				Vertical Openings Protected?			YES	-
		1675	1675	1675					2512.5	-
3	Determine Required Fire Flow	(F = 220 x C x A <sup>1/2</sup> ). Round to nearest 1000 L/min							-	10000
4	Determine Occupancy Charge	Limited Combustible							-15%	8500
5	Determine Sprinkler Reduction	Conforms to NFPA 13							-30%	-4250
		Standard Water Supply							-10%	
		Fully Supervised							-10%	
		% Coverage of Sprinkler System							100%	
6	Determine Increase for Exposures (Max. 75%)	Direction	Exposure Distance (m)	Exposed Length (m)	Exposed Height (Stories)	Length-Height Factor (m x stories)	Construction of Adjacent Wall	Firewall / Sprinklered ?	-	-
		North	10.1 to 20	23	4	81-100	Type I-II - Protected Openings	YES	0%	1275
		East	10.1 to 20	67	2	> 100	Type V	NO	15%	
		South	> 30	0	0	0-20	Type V	NO	0%	
		West	10.1 to 20	46	4	> 100	Type III-IV - Protected Openings	YES	0%	
7	Determine Final Required Fire Flow	Total Required Fire Flow in L/min, Rounded to Nearest 1000L/min								6000
		Total Required Fire Flow in L/s								100.0
		Required Duration of Fire Flow (hrs)								2.00
		Required Volume of Fire Flow (m <sup>3</sup> )								720



FUS Fire Flow Calculation Sheet - 2020 FUS Guidelines

Stantec Project #: 160401536  
 Project Name: Ridgewood Avenue  
 Date: 6/30/2022

Fire Flow Calculation #: 3  
 Description: Building IV

Notes: Mixed-use - 2-4th Floors considered as wood frame, first floor non-combustible construction, predominantly residential.  
 Sprinklered with floor assemblies / load bearing walls as 1hr rated assemblies per OBC 3.2.2.52

Step	Task	Notes							Value Used	Req'd Fire Flow (L/min)
1	Determine Type of Construction	Type IV-B Mass Timber Construction							0.9	-
2	Determine Effective Floor Area	Sum of Largest Floor + 25% of Two Additional Floors				Vertical Openings Protected?			YES	-
		1511	1511	1511					2266.5	-
3	Determine Required Fire Flow	(F = 220 x C x A <sup>1/2</sup> ). Round to nearest 1000 L/min							-	9000
4	Determine Occupancy Charge	Limited Combustible							-15%	7650
5	Determine Sprinkler Reduction	Conforms to NFPA 13							-30%	-3825
		Standard Water Supply							-10%	
		Fully Supervised							-10%	
		% Coverage of Sprinkler System							100%	
6	Determine Increase for Exposures (Max. 75%)	Direction	Exposure Distance (m)	Exposed Length (m)	Exposed Height (Stories)	Length-Height Factor (m x stories)	Construction of Adjacent Wall	Firewall / Sprinklered ?	-	-
		North	> 30	0	0	0-20	Type I-II - Protected Openings	YES	0%	0
		East	10.1 to 20	46	4	> 100	Type III-IV - Protected Openings	YES	0%	
		South	> 30	0	0	0-20	Type V	NO	0%	
		West	> 30	0	0	0-20	Type V	NO	0%	
7	Determine Final Required Fire Flow	Total Required Fire Flow in L/min, Rounded to Nearest 1000L/min								4000
		Total Required Fire Flow in L/s								66.7
		Required Duration of Fire Flow (hrs)								1.50
		Required Volume of Fire Flow (m <sup>3</sup> )								360

**SITE SERVICING AND STORMWATER MANAGEMENT BRIEF – MOONEY’S BAY - 729  
RIDGEWOOD AVENUE, OTTAWA, ON**

Appendix B Proposed Site Plan

## **Appendix B PROPOSED SITE PLAN**







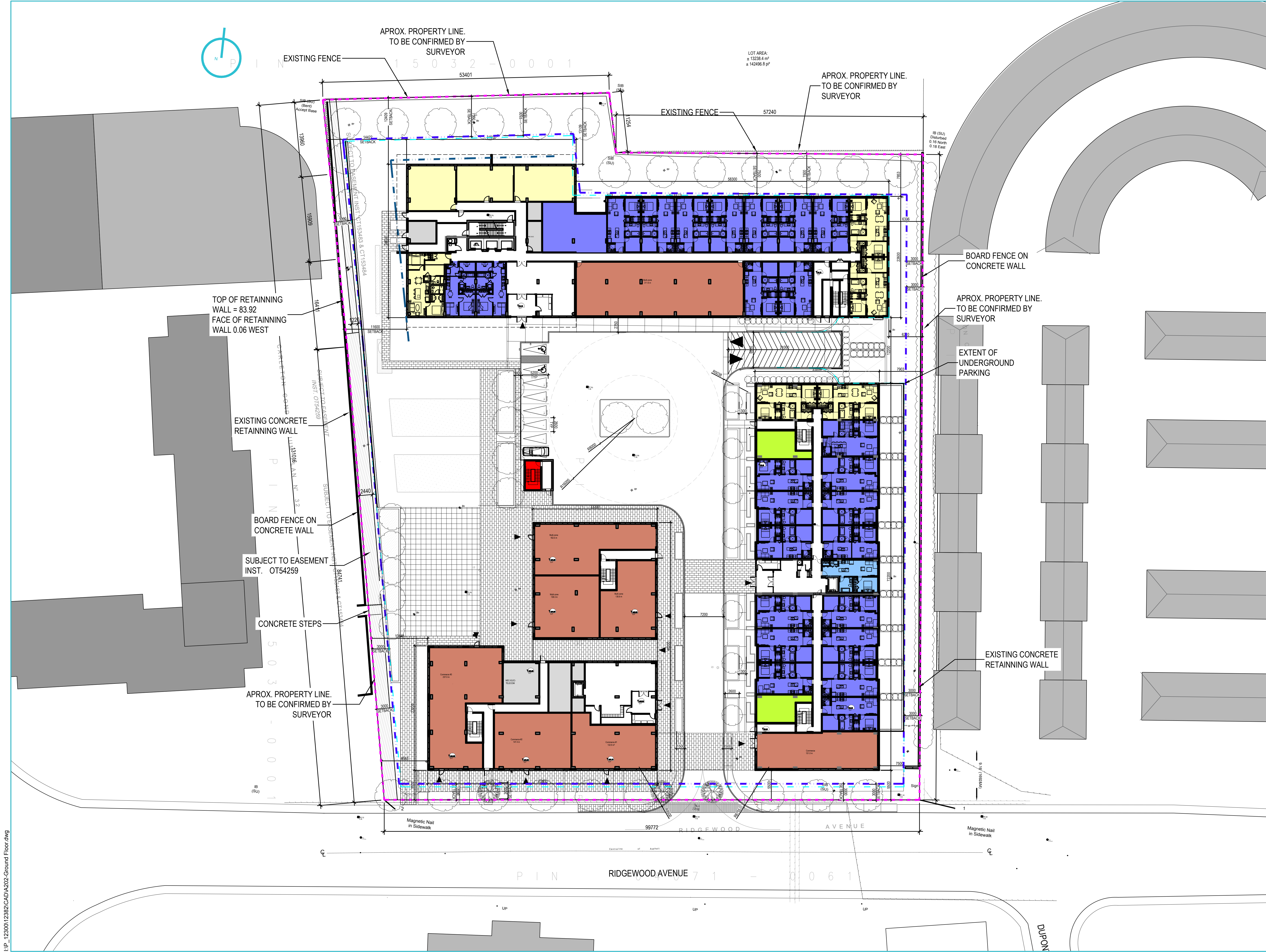

NOTES GÉNÉRALES / General Notes

- Ces documents d'architecture sont la propriété exclusive de NEUF architectes, et ne doivent être utilisés, reproduits ou copiés sans autorisation écrite au préalable. / These architectural documents are the exclusive property of NEUF architectes and cannot be used, copied or reproduced without written pre-authorization.
- Les dimensions apparaissant sur ces documents doivent être vérifiées par l'entrepreneur avant le début des travaux. / All dimensions which appear on the documents must be verified by the contractor before starting the work.
- Veuillez aviser l'architecte de toute dimension erronée et/ou divergences entre ces documents et ceux des autres professionnels. / The architect must be notified of all errors, omissions and/or discrepancies between these documents and those of other professionals.
- Les dimensions sur ces documents doivent être lues et non mesurées. / The dimensions on these documents must be read and not measured.

PLANIFICATEUR / Planner  
**FOTENN Planning and Urban design**  
 398, Cooper Street, Ottawa, ON K2P 2H7  
 T 613 730 5709 www.fotenn.com

ARCHITECTURE DE PAYSAGE / Landscape architect  
**LEVSTEK CONSULTANTS Inc**  
 5871, High Crescent, Ottawa, ON K1A 2W0  
 T 613 526 5515 www.landscapelevstek.com

INGÉNIEUR TRANSPORT / Engineering, Transportation  
**PARSONS**  
 100-1222, Metcalfe Street Suite 100, Ottawa, ON K1J 7T2  
 T 613 738 4160 www.parsons.com

CIVIL / Civil  
**STANTEC**  
 1331, Clyde Ave., Suite 400, Ottawa, ON K2C 3G4  
 T 613 722 4420 www.stantec.com

ARCHITECTES / Architect  
**NEUF architect(e)s**  
 630, boul. René-Lévesque O., 32e étage, Montréal QC H3B 1S6  
 T 514 847 1117 NEUFarchitectes.com

GEOTECHNIQUE / Geotechnical  
**PATERSON GROUP**  
 154 Colomnade Rd S, Nepean, On. K2E 7J5  
 T 613 226 7381 www.me-eng.com

CONSERVATION DES ARBRES / Tree Conservation  
**BOWFIN**  
 168 Montreal Rd., Cornwall, ON K6H 1H3  
 T 613 535 5139 www.bowfinenvironmental.ca

ENVIRONNEMENT / Environmental (ESA)  
**LOPERS ASSOCIATES**

SCEAU / Seal

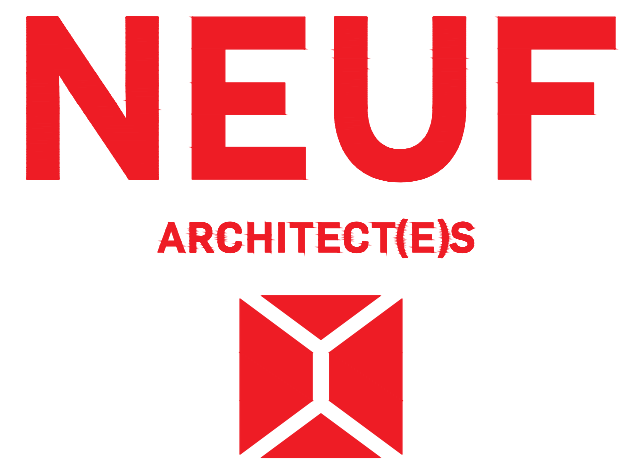

CLIENT / Client  
**brigil**  
 98 Lois, Gatineau, Qc J8Y 3R7  
 T 819 243 7392 brigil.com

OUVRAGE / Project  
**MOONEY'S BAY**

EMPLACEMENT / Location  
 OTTAWA, ON

NO PROJET / No.  
 12382.00

NO	REVISION	DATE (aa.mm.jj)
A	For Comments	2022.06.07
B	For Comments	2022.06.09

DESSIN PAR / Drawn by  
 O.C.

VERIFIÉ PAR / Checked by  
 ANT. C.F.P.

DATE (aa.mm.jj)  
 22.06.08

ECHELLE / Scale  
 1:300

TITRE DU DESSIN / Drawing Title  
**Ground Floor**

REVISION / Revision  
**B**

NO. DESSIN / Dwg Number  
**A203**

I:\P\_123001\12382\CAD\A202-Ground Floor.dwg

## **Appendix C SANITARY SEWER CALCULATIONS**





SUBDIVISION:  
**Mooney's Bay - 729 Ridgewood Avenue**

DATE: 6/30/2022  
 REVISION: 1  
 DESIGNED BY: DT  
 CHECKED BY:

**SANITARY SEWER  
 DESIGN SHEET  
 (City of Ottawa)**

FILE NUMBER: 160410536

**DESIGN PARAMETERS**

MAX PEAK FACTOR (RES.)=	4.0	AVG. DAILY FLOW / PERSON	280 L/p/day	MINIMUM VELOCITY	0.60 m/s
MIN PEAK FACTOR (RES.)=	2.0	COMMERCIAL	28,000 L/ha/day	MAXIMUM VELOCITY	3.00 m/s
PEAKING FACTOR (INDUSTRIAL):	2.4	INDUSTRIAL (HEAVY)	55,000 L/ha/day	MANNINGS n	0.013
PEAKING FACTOR (ICI >20%):	1.5	INDUSTRIAL (LIGHT)	35,000 L/ha/day	BEDDING CLASS	B
PERSONS / 1 BEDROOM	1.4	INSTITUTIONAL	28,000 L/ha/day	MINIMUM COVER	2.50 m
PERSONS / 2 BEDROOM	2.1				
PERSONS / 3 BEDROOM	3.1	INFILTRATION	0.33 L/s/ha	HARMON CORRECTION FACTOR	0.8
PERSONS / TOWNHOME	2.7				

LOCATION			RESIDENTIAL AREA AND POPULATION							COMMERCIAL		INDUSTRIAL (L)		INDUSTRIAL (H)		INSTITUTIONAL		GREEN / UNUSED		C+H	INFILTRATION			TOTAL	PIPE									
AREA ID NUMBER	FROM M.H.	TO M.H.	AREA (ha)	1 BEDROOM	2 BEDROOM	3 BEDROOM	TOWNHOME	POP.	CUMULATIVE AREA (ha)	POP.	PEAK FACT.	PEAK FLOW (L/s)	AREA (ha)	ACCU. AREA (ha)	AREA (ha)	ACCU. AREA (ha)	AREA (ha)	ACCU. AREA (ha)	AREA (ha)	ACCU. AREA (ha)	PEAK FLOW (L/s)	TOTAL AREA (ha)	ACCU. AREA (ha)	INFILT. FLOW (L/s)	FLOW (L/s)	LENGTH (m)	DIA (mm)	MATERIAL	CLASS	SLOPE (%)	CAP. (FULL) (l/s)	CAP. V. PEAK FLOW (%)	VEL. (FULL) (m/s)	VEL. (ACT.) (m/s)
Proposed Site	BLDG	SAN10	0.478	326	84	36	0	744	0.478	744	3.88	9.36	0.072	0.072	0.000	0.00	0.000	0.00	0.000	0.00	0.04	1.330	1.330	0.44	9.83	1.5	200	PVC	SDR 35	2.00	47.3	20.79%	1.49	0.98
	SAN10	EX. SANMH2	0.000	0	0	0	0	0	0.478	744	3.88	9.36	0.000	0.072	0.000	0.00	0.000	0.00	0.000	0.00	0.04	0.000	1.330	0.44	9.83	10.8	200	PVC	SDR 35	0.50	23.6	41.58%	0.74	0.60

**From:** [Rasool, Rubina](#)  
**To:** [Paerez, Ana](#)  
**Cc:** [Kilborn, Kris](#); [Sharp, Mike](#)  
**Subject:** RE: 729 Ridgewood Avenue Site  
**Date:** Wednesday, May 26, 2021 1:06:13 PM

---

The City has not identified concerns with the proposed flows.

**Rubina**

---

**Rubina Rasool, E.I.T.**

Project Manager

Planning, Infrastructure and Economic Development Department - Services de la planification, de l'infrastructure et du développement économique

Development Review – East Branch

City of Ottawa | Ville d'Ottawa

110 Laurier Avenue West Ottawa, ON | 110, avenue Laurier Ouest. Ottawa (Ontario) K1P 1J1

[rubina.rasool@ottawa.ca](mailto:rubina.rasool@ottawa.ca)

---

**From:** Rasool, Rubina

**Sent:** May 21, 2021 1:29 PM

**To:** Paerez, Ana <[Ana.Paerez@stantec.com](mailto:Ana.Paerez@stantec.com)>

**Cc:** Kilborn, Kris <[kris.kilborn@stantec.com](mailto:kris.kilborn@stantec.com)>; Sharp, Mike <[Mike.Sharp@stantec.com](mailto:Mike.Sharp@stantec.com)>

**Subject:** RE: 729 Ridgewood Avenue Site

Hi Ana,

I have forwarded your request to Asset Management and should receive a response next week.

Have a good long weekend

**Rubina**

---

**Rubina Rasool, E.I.T.**

Project Manager

Planning, Infrastructure and Economic Development Department - Services de la planification, de l'infrastructure et du développement économique

Development Review – East Branch

City of Ottawa | Ville d'Ottawa

110 Laurier Avenue West Ottawa, ON | 110, avenue Laurier Ouest. Ottawa (Ontario) K1P 1J1

[rubina.rasool@ottawa.ca](mailto:rubina.rasool@ottawa.ca)

---

**From:** Paerez, Ana <[Ana.Paerez@stantec.com](mailto:Ana.Paerez@stantec.com)>

**Sent:** May 21, 2021 12:35 PM

**To:** Rasool, Rubina <[Rubina.Rasool@ottawa.ca](mailto:Rubina.Rasool@ottawa.ca)>

**Cc:** Kilborn, Kris <[kris.kilborn@stantec.com](mailto:kris.kilborn@stantec.com)>; Sharp, Mike <[Mike.Sharp@stantec.com](mailto:Mike.Sharp@stantec.com)>

**Subject:** 729 Ridgewood Avenue Site

**CAUTION: This email originated from an External Sender. Please do not click links or open attachments unless you recognize the source.**

**ATTENTION : Ce courriel provient d'un expéditeur externe. Ne cliquez sur aucun lien et n'ouvrez pas de pièce jointe, excepté si vous connaissez l'expéditeur.**

Good afternoon Rubina,

We are working on a mixed-use (residential/commercial site) on 729 Ridgewood Avenue that will consist of 5 multi-storey buildings with 387 apartment units and retail area on the ground floor of one of the buildings fronting on Ridgewood Avenue.

The sanitary peak flows from the proposed site are approximately 8.72 L/s. Would it be possible for the City to confirm if the downstream sanitary sewers have sufficient capacity for the proposed flows.

Thank you very much for your feedback,

**Ana Paerez** P. Eng.

Water Resources Engineer

Direct: 506 204-5856

Fax: 506 858-8698

[Ana.Paerez@stantec.com](mailto:Ana.Paerez@stantec.com)

Stantec

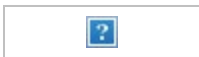

The content of this email is the confidential property of Stantec and should not be copied, modified, retransmitted, or used for any purpose except with Stantec's written authorization. If you are not the intended recipient, please delete all copies and notify us immediately.

This e-mail originates from the City of Ottawa e-mail system. Any distribution, use or copying of this e-mail or the information it contains by other than the intended recipient(s) is unauthorized. Thank you.

Le présent courriel a été expédié par le système de courriels de la Ville d'Ottawa. Toute distribution, utilisation ou reproduction du courriel ou des renseignements qui s'y trouvent par une personne autre que son destinataire prévu est interdite. Je vous remercie de votre collaboration.

## **Appendix D STORMWATER MANAGEMENT CALCULATIONS**





729 Ridgewood Avenue - Brigid Homes

**STORM SEWER  
DESIGN SHEET  
(City of Ottawa)**  
Existing Development Conditions to estimate time of concentration  
**FILE NUMBER: 160404536**

**DESIGN PARAMETERS**

$I = a / (t+b)^2$  (As per City of Ottawa Guidelines, 2012)

	1:2 yr	1.5 yr	1:10 yr	1:100 yr
a =	732.951	998.071	1174.184	1735.688
b =	6.199	6.053	6.014	6.014
c =	0.810	0.814	0.816	0.820

MANNING'S n = 0.013  
BEDDING CLASS = B  
MINIMUM COVER: 2.00 m  
TIME OF ENTRY: 10 min

LOCATION			DRAINAGE AREA																	PIPE SELECTION																				
AREA ID NUMBER	FROM M.H.	TO M.H.	AREA (2-YEAR) (ha)	AREA (5-YEAR) (ha)	AREA (10-YEAR) (ha)	AREA (100-YEAR) (ha)	AREA (ROOF) (ha)	C (2-YEAR) (-)	C (5-YEAR) (-)	C (10-YEAR) (-)	C (100-YEAR) (-)	A x C (2-YEAR) (ha)	ACCUM A x C (2YR) (ha)	A x C (5-YEAR) (ha)	ACCUM A x C (5YR) (ha)	A x C (10-YEAR) (ha)	ACCUM A x C (10YR) (ha)	A x C (100-YEAR) (ha)	ACCUM A x C (100YR) (ha)	T of C (min)	I <sub>2-YEAR</sub> (mm/h)	I <sub>5-YEAR</sub> (mm/h)	I <sub>10-YEAR</sub> (mm/h)	I <sub>100-YEAR</sub> (mm/h)	Q <sub>CONTROL</sub> (L/s)	ACCUM. Q <sub>CONTROL</sub> (L/s)	Q <sub>ACT</sub> (CIA/360) (L/s)	LENGTH (m)	PIPE WIDTH OR DIAMETE (mm)	PIPE HEIGHT (mm)	PIPE SHAPE (-)	MATERIAL (-)	CLASS (-)	SLOPE (%)	Q <sub>cap</sub> (FULL) (L/s)	% FULL (-)	VEL (FULL) (m/s)	VEL (ACT) (m/s)	TIME OF FLOW (min)	
Half of existing Site	CB1	CB2	0.66	0.00	0.00	0.00	0.00	0.90	0.00	0.00	0.00	0.594	0.594	0.000	0.000	0.000	0.000	0.000	0.000	0.000	10.00	76.81	104.19	122.14	178.56	0.0	0.0	126.7	153.0	300	300	CIRCULAR	PVC	-	2.00	136.0	93.20%	1.93	1.99	1.28
Half of Existing Site	CB2	STM	0.66	0.00	0.00	0.00	0.00	0.90	0.00	0.00	0.00	0.594	1.188	0.000	0.000	0.000	0.000	0.000	0.000	0.000	11.28	72.21	97.88	114.70	167.63	0.0	0.0	238.3	86.0	300	300	CIRCULAR	PVC	-	2.00	136.0	175.24%	1.93	1.93	0.74
<b>12.02</b>																																								



Stantec

Mooney's Bay - 729 Ridgewood Avenue

STORM SEWER DESIGN SHEET (City of Ottawa)

DESIGN PARAMETERS

I = a / (t+b)^c (As per City of Ottawa Guidelines, 2012)

DATE: 2021-06-09
REVISION: 1
DESIGNED BY: DT
CHECKED BY: KK

FILE NUMBER: 160401536

Table with 4 columns: 1:2 yr, 1:5 yr, 1:10 yr, 1:100 yr. Rows for a, b, c values.

MANNING'S n = 0.013
BEDDING CLASS = B
MINIMUM COVER: 2.00 m
TIME OF ENTRY: 10 min

Main data table with columns: LOCATION, DRAINAGE AREA, and PIPE SELECTION. Includes rows for ROOF1-4, TANK1-6.



### Stormwater Management Calculations

File No: 160401536  
 Project: 729 Ridgewood Avenue - Brigil Homes  
 Date: 30-Jun-22

SWM Approach:  
 Restrict 100-year peak flows from entire site to 2-year storm as per existing development conditions

**Post-Development Site Conditions:**

**Overall Runoff Coefficient for Site and Sub-Catchment Areas**

Runoff Coefficient Table						
Sub-catchment Area	Area (ha)	Runoff Coefficient "C"	"A x C"	Overall Runoff Coefficient		
Catchment Type	ID / Description	"A"	"C"	"A x C"		
Roof	ROOF_1	Hard Soft	0.090 0.000	0.9 0.2	0.081 0.000	
	Subtotal			0.09	0.081	0.900
Roof	ROOF_2	Hard Soft	0.052 0.078	0.9 0.2	0.047 0.016	
	Subtotal			0.13	0.062	0.480
Roof	ROOF_3	Hard Soft	0.170 0.000	0.9 0.2	0.153 0.000	
	Subtotal			0.17	0.153	0.900
Roof	ROOF_4	Hard Soft	0.150 0.000	0.9 0.2	0.135 0.000	
	Subtotal			0.15	0.135	0.900
Uncontrolled - Tributary	TANK 6	Hard Soft	0.025 0.005	0.9 0.2	0.023 0.001	
	Subtotal			0.03	0.0237	0.790
Uncontrolled - Tributary	TANK 1	Hard Soft	0.080 0.080	0.9 0.2	0.072 0.016	
	Subtotal			0.16	0.088	0.550
Uncontrolled - Tributary	TANK 2	Hard Soft	0.166 0.024	0.9 0.2	0.149 0.005	
	Subtotal			0.19	0.1539	0.810
Uncontrolled - Tributary	TANK 3	Hard Soft	0.044 0.006	0.9 0.2	0.039 0.001	
	Subtotal			0.05	0.0405	0.810
Uncontrolled - Tributary	TANK 4	Hard Soft	0.004 0.146	0.9 0.2	0.004 0.029	
	Subtotal			0.15	0.033	0.220
Uncontrolled - Tributary	TANK 5	Hard Soft	0.002 0.078	0.9 0.2	0.002 0.016	
	Subtotal			0.08	0.0176	0.220
Uncontrolled - Non-Tributary	UNC-1	Hard Soft	0.048 0.082	0.9 0.2	0.043 0.016	
	Subtotal			0.13	0.0598	0.460
Controlled - Tributary	CISTERN	Hard Soft	0.000 0.000	0.9 0.2	0.000 0.000	
	Subtotal			0.0E+00	0.0E+00	0.000
<b>Total</b>			<b>1.330</b>		<b>0.848</b>	
<b>Overall Runoff Coefficient= C:</b>						<b>0.64</b>

Total Roof Areas	0.540 ha
Total Tributary Surface Areas (Controlled and Uncontrolled)	0.660 ha
Total Tributary Area to Outlet	1.200 ha
 Total Uncontrolled Areas (Non-Tributary)	 0.130 ha
 Total Site	 1.330 ha

# Stormwater Management Calculations

**Project #160401536, 729 Ridgewood Avenue - Brigil Homes**  
**Modified Rational Method Calculators for Storage**

2 yr Intensity City of Ottawa	$I = a/(t + b)$	a = 732.951	t (min)	I (mm/hr)
		b = 6.199	10	76.81
		c = 0.81	20	52.03
			30	40.04
			40	32.86
			50	28.04
			60	24.56
			70	21.91
			80	19.83
			90	18.14
			100	16.75
			110	15.57
			120	14.56

**Target Release for Overall Site**

Subdrainage Area: Restrict to 2-yr pre-development rate (C=0.80) per Sawmill Creek Subwatershed Study  
 Area (ha): 1.3300  
 C: 0.80

Typical Time of Concentration

tc (min)	I (2 yr) (mm/hr)	Qtarget (L/s)
12.38	68.73	203.3

**2 YEAR Modified Rational Method for Entire Site**

Subdrainage Area: ROOF\_1  
 Area (ha): 0.09  
 C: 0.90  
 Maximum Storage Depth: 150 mm

tc (min)	I (2 yr) (mm/hr)	Qactual (L/s)	Qrelease (L/s)	Qstored (L/s)	Vstored (m³)	Depth (mm)
10	76.81	17.3	3.5	13.8	8.3	90.2
20	52.03	11.7	3.7	8.0	9.6	95.8
30	40.04	9.0	3.7	5.3	9.6	95.7
40	32.86	7.4	3.6	3.8	9.1	93.5
50	28.04	6.3	3.5	2.8	8.3	90.4
60	24.56	5.5	3.5	2.1	7.5	87.0
70	21.91	4.9	3.4	1.6	6.6	83.4
80	19.83	4.5	3.3	1.2	5.7	79.9
90	18.14	4.1	3.2	0.9	4.8	76.4
100	16.75	3.8	3.1	0.7	4.1	72.1
110	15.57	3.5	3.0	0.5	3.6	67.6
120	14.56	3.3	2.9	0.4	3.0	63.3

Storage: Roof Storage

Depth (mm)	Head (m)	Discharge (L/s)	Vreq (cu. m)	Vavail (cu. m)	Discharge Check
5-year Water Level	95.8	0.10	3.7	9.6	36.0

Subdrainage Area: ROOF\_2  
 Area (ha): 0.13  
 C: 0.48  
 Maximum Storage Depth: 150 mm

tc (min)	I (2 yr) (mm/hr)	Qactual (L/s)	Qrelease (L/s)	Qstored (L/s)	Vstored (m³)	Depth (mm)
10	76.81	13.3	3.6	9.7	5.8	71.4
20	52.03	9.0	3.7	5.3	6.3	74.1
30	40.04	6.9	3.6	3.3	6.0	72.0
40	32.86	5.7	3.5	2.2	5.4	68.7
50	28.04	4.9	3.3	1.6	4.7	65.2
60	24.56	4.3	3.1	1.1	4.1	61.9
70	21.91	3.8	3.0	0.8	3.5	58.7
80	19.83	3.4	2.8	0.6	3.0	55.8
90	18.14	3.1	2.7	0.5	2.5	53.2
100	16.75	2.9	2.6	0.3	2.1	50.7
110	15.57	2.7	2.4	0.3	1.8	48.1
120	14.56	2.5	2.3	0.2	1.6	45.6

Storage: Roof Storage

Depth (mm)	Head (m)	Discharge (L/s)	Vreq (cu. m)	Vavail (cu. m)	Discharge Check
5-year Water Level	74.1	0.07	3.7	6.3	52.0

Subdrainage Area: ROOF\_3  
 Area (ha): 0.17  
 C: 0.90  
 Maximum Storage Depth: 150 mm

tc (min)	I (2 yr) (mm/hr)	Qactual (L/s)	Qrelease (L/s)	Qstored (L/s)	Vstored (m³)	Depth (mm)
10	76.81	32.7	6.1	26.6	15.9	91.0
20	52.03	22.1	6.5	15.7	18.8	97.1
30	40.04	17.0	6.5	10.5	19.0	97.5
40	32.86	14.0	6.4	7.6	18.2	95.9
50	28.04	11.9	6.2	5.7	17.0	93.3
60	24.56	10.4	6.1	4.4	15.7	90.5
70	21.91	9.3	5.9	3.4	14.3	87.5
80	19.83	8.4	5.7	2.7	12.9	84.5
90	18.14	7.7	5.6	2.1	11.6	81.6
100	16.75	7.1	5.4	1.7	10.2	78.7
110	15.57	6.6	5.3	1.4	9.0	76.0
120	14.56	6.2	5.1	1.1	8.0	72.9

Storage: Roof Storage

Depth (mm)	Head (m)	Discharge (L/s)	Vreq (cu. m)	Vavail (cu. m)	Discharge Check
5-year Water Level	97.5	0.10	6.5	19.0	68.0

**Project #160401536, 729 Ridgewood Avenue - Brigil Homes**  
**Modified Rational Method Calculators for Storage**

100 yr Intensity City of Ottawa	$I = a/(t + b)$	a = 1735.688	t (min)	I (mm/hr)
		b = 6.014	10	178.56
		c = 0.820	20	119.95
			30	91.87
			40	75.15
			50	63.95
			60	55.89
			70	49.79
			80	44.99
			90	41.11
			100	37.90
			110	35.20
			120	32.89

**100 YEAR Modified Rational Method for Entire Site**

Subdrainage Area: ROOF\_1  
 Area (ha): 0.09  
 C: 1.00  
 Maximum Storage Depth: 150 mm

tc (min)	I (100 yr) (mm/hr)	Qactual (L/s)	Qrelease (L/s)	Qstored (L/s)	Vstored (m³)	Depth (mm)
10	178.56	44.7	4.6	40.1	24.1	130.3
20	119.95	30.0	4.8	25.2	30.2	140.5
30	91.87	23.0	4.9	18.1	32.5	144.3
40	75.15	18.8	4.9	13.9	33.3	145.5
50	63.95	16.0	4.9	11.1	33.2	145.4
60	55.89	14.0	4.9	9.1	32.7	144.5
70	49.79	12.5	4.9	7.6	31.8	143.2
80	44.99	11.3	4.8	6.4	30.8	141.5
90	41.11	10.3	4.8	5.5	29.7	139.6
100	37.90	9.5	4.7	4.7	28.5	137.6
110	35.20	8.8	4.7	4.1	27.2	135.5
120	32.89	8.2	4.6	3.6	25.9	133.4

Storage: Roof Storage

Depth (mm)	Head (m)	Discharge (L/s)	Vreq (cu. m)	Vavail (cu. m)	Discharge Check
100-year Water Level	145.5	0.15	4.9	33.3	36.0

Subdrainage Area: ROOF\_2  
 Area (ha): 0.13  
 C: 0.60  
 Maximum Storage Depth: 150 mm

tc (min)	I (100 yr) (mm/hr)	Qactual (L/s)	Qrelease (L/s)	Qstored (L/s)	Vstored (m³)	Depth (mm)
10	178.56	38.7	5.4	33.3	20.0	107.8
20	119.95	26.0	5.8	20.2	24.2	115.0
30	91.87	19.9	5.9	14.0	25.2	116.8
40	75.15	16.3	5.9	10.4	25.0	116.4
50	63.95	13.9	5.8	8.1	24.2	115.0
60	55.89	12.1	5.7	6.4	23.1	113.1
70	49.79	10.8	5.6	5.2	21.8	110.9
80	44.99	9.8	5.5	4.3	20.5	108.7
90	41.11	8.9	5.4	3.5	19.1	106.4
100	37.90	8.2	5.3	3.0	17.8	104.1
110	35.20	7.6	5.1	2.5	16.5	101.8
120	32.89	7.1	5.0	2.1	15.2	99.5

Storage: Roof Storage

Depth (mm)	Head (m)	Discharge (L/s)	Vreq (cu. m)	Vavail (cu. m)	Discharge Check
100-year Water Level	116.8	0.12	5.9	25.2	52.0

Subdrainage Area: ROOF\_3  
 Area (ha): 0.17  
 C: 1.00  
 Maximum Storage Depth: 150 mm

tc (min)	I (100 yr) (mm/hr)	Qactual (L/s)	Qrelease (L/s)	Qstored (L/s)	Vstored (m³)	Depth (mm)
10	178.56	84.4	8.4	76.0	45.6	130.5
20	119.95	56.7	8.9	47.8	57.3	140.7
30	91.87	43.4	9.2	34.3	61.7	144.5
40	75.15	35.5	9.2	26.3	63.1	145.7
50	63.95	30.2	9.2	21.0	63.0	145.7
60	55.89	26.4	9.2	17.2	62.1	144.8
70	49.79	23.5	9.1	14.4	60.6	143.6
80	44.99	21.3	9.0	12.3	58.8	142.0
90	41.11	19.4	8.9	10.5	56.8	140.2
100	37.90	17.9	8.8	9.1	54.7	138.4
110	35.20	16.6	8.7	7.9	52.4	136.4
120	32.89	15.5	8.6	7.0	50.2	134.4

Storage: Roof Storage

Depth (mm)	Head (m)	Discharge (L/s)	Vreq (cu. m)	Vavail (cu. m)	Discharge Check
100-year Water Level	145.7	0.15	9.2	63.1	68.0

# Stormwater Management Calculations

**Project #160401536, 729 Ridgewood Avenue - Brigil Homes**  
**Modified Rational Method Calculators for Storage**

<b>Subdrainage Area:</b> ROOF_4		Roof	
<b>Area (ha):</b> 0.15	<b>Maximum Storage Depth:</b>		150 mm
<b>C:</b> 0.90			

tc (min)	I (2 yr) (mm/hr)	Qactual (L/s)	Qrelease (L/s)	Qstored (L/s)	Vstored (m <sup>3</sup> )	Depth (mm)	
10	76.81	28.8	4.6	24.2	14.5	92.0	0.0
20	52.03	19.5	5.0	14.5	17.4	99.1	0.0
30	40.04	15.0	5.1	10.0	17.9	100.2	0.0
40	32.86	12.3	5.0	7.3	17.6	99.5	0.0
50	28.04	10.5	4.9	5.6	16.8	97.6	0.0
60	24.56	9.2	4.8	4.4	15.9	95.3	0.0
70	21.91	8.2	4.7	3.5	14.9	92.9	0.0
80	19.83	7.4	4.6	2.9	13.8	90.4	0.0
90	18.14	6.8	4.4	2.4	12.8	87.9	0.0
100	16.75	6.3	4.3	2.0	11.8	85.5	0.0
110	15.57	5.8	4.2	1.6	10.9	83.2	0.0
120	14.56	5.5	4.1	1.4	9.9	80.9	0.0

Storage: Roof Storage

Depth (mm)	Head (m)	Discharge (L/s)	Vreq (cu. m)	Vavail (cu. m)	Discharge Check
100.2	0.10	5.1	17.9	60.0	0.4

5-year Water Level

**Project #160401536, 729 Ridgewood Avenue - Brigil Homes**  
**Modified Rational Method Calculators for Storage**

<b>Subdrainage Area:</b> ROOF_4		Roof	
<b>Area (ha):</b> 0.15	<b>Maximum Storage Depth:</b>		150 mm
<b>C:</b> 1.00			

tc (min)	I (100 yr) (mm/hr)	Qactual (L/s)	Qrelease (L/s)	Qstored (L/s)	Vstored (m <sup>3</sup> )	Depth (mm)	
10	178.56	74.5	6.6	67.9	40.7	130.9	0.00
20	119.95	50.0	7.1	42.9	51.5	141.5	0.00
30	91.87	38.3	7.4	31.0	55.7	145.8	0.00
40	75.15	31.3	7.4	23.9	57.4	147.4	0.00
50	63.95	26.7	7.5	19.2	57.6	147.7	0.00
60	55.89	23.3	7.4	15.9	57.2	147.2	0.00
70	49.79	20.8	7.4	13.4	56.2	146.2	0.00
80	44.99	18.8	7.3	11.4	54.9	145.0	0.00
90	41.11	17.1	7.2	9.9	53.5	143.5	0.00
100	37.90	15.8	7.2	8.6	51.8	141.9	0.00
110	35.20	14.7	7.1	7.6	50.2	140.3	0.00
120	32.89	13.7	7.0	6.7	48.4	138.5	0.00

Storage: Roof Storage

Depth (mm)	Head (m)	Discharge (L/s)	Vreq (cu. m)	Vavail (cu. m)	Discharge Check
147.7	0.15	7.5	57.6	60.0	0.8

100-year Water Level

<b>Subdrainage Area:</b> TANK 6		Uncontrolled - Tributary	
<b>Area (ha):</b> 0.03			
<b>C:</b> 0.79			

tc (min)	I (2 yr) (mm/hr)	Qactual (L/s)	Qrelease (L/s)	Qstored (L/s)	Vstored (m <sup>3</sup> )
10	76.81	5.1	5.1		
20	52.03	3.4	3.4		
30	40.04	2.6	2.6		
40	32.86	2.2	2.2		
50	28.04	1.8	1.8		
60	24.56	1.6	1.6		
70	21.91	1.4	1.4		
80	19.83	1.3	1.3		
90	18.14	1.2	1.2		
100	16.75	1.1	1.1		
110	15.57	1.0	1.0		
120	14.56	1.0	1.0		

<b>Subdrainage Area:</b> TANK 6		Uncontrolled - Tributary	
<b>Area (ha):</b> 0.03			
<b>C:</b> 0.99			

tc (min)	I (100 yr) (mm/hr)	Qactual (L/s)	Qrelease (L/s)	Qstored (L/s)	Vstored (m <sup>3</sup> )
10	178.56	14.7	14.7		
20	119.95	9.9	9.9		
30	91.87	7.6	7.6		
40	75.15	6.2	6.2		
50	63.95	5.3	5.3		
60	55.89	4.6	4.6		
70	49.79	4.1	4.1		
80	44.99	3.7	3.7		
90	41.11	3.4	3.4		
100	37.90	3.1	3.1		
110	35.20	2.9	2.9		
120	32.89	2.7	2.7		

<b>Subdrainage Area:</b> TANK 1		Uncontrolled - Tributary	
<b>Area (ha):</b> 0.16			
<b>C:</b> 0.55			

tc (min)	I (2 yr) (mm/hr)	Qactual (L/s)	Qrelease (L/s)	Qstored (L/s)	Vstored (m <sup>3</sup> )
10	76.81	18.8	18.8		
20	52.03	12.7	12.7		
30	40.04	9.8	9.8		
40	32.86	8.0	8.0		
50	28.04	6.9	6.9		
60	24.56	6.0	6.0		
70	21.91	5.4	5.4		
80	19.83	4.9	4.9		
90	18.14	4.4	4.4		
100	16.75	4.1	4.1		
110	15.57	3.8	3.8		
120	14.56	3.6	3.6		

<b>Subdrainage Area:</b> TANK 1		Uncontrolled - Tributary	
<b>Area (ha):</b> 0.16			
<b>C:</b> 0.69			

tc (min)	I (100 yr) (mm/hr)	Qactual (L/s)	Qrelease (L/s)	Qstored (L/s)	Vstored (m <sup>3</sup> )
10	178.56	54.6	54.6		
20	119.95	36.7	36.7		
30	91.87	28.1	28.1		
40	75.15	23.0	23.0		
50	63.95	19.6	19.6		
60	55.89	17.1	17.1		
70	49.79	15.2	15.2		
80	44.99	13.8	13.8		
90	41.11	12.6	12.6		
100	37.90	11.6	11.6		
110	35.20	10.8	10.8		
120	32.89	10.1	10.1		

<b>Subdrainage Area:</b> TANK 2		Uncontrolled - Tributary	
<b>Area (ha):</b> 0.19			
<b>C:</b> 0.81			

tc (min)	I (2 yr) (mm/hr)	Qactual (L/s)	Qrelease (L/s)	Qstored (L/s)	Vstored (m <sup>3</sup> )
10	76.81	32.9	32.9		
20	52.03	22.3	22.3		
30	40.04	17.1	17.1		
40	32.86	14.1	14.1		
50	28.04	12.0	12.0		
60	24.56	10.5	10.5		
70	21.91	9.4	9.4		
80	19.83	8.5	8.5		
90	18.14	7.8	7.8		
100	16.75	7.2	7.2		
110	15.57	6.7	6.7		
120	14.56	6.2	6.2		

<b>Subdrainage Area:</b> TANK 2		Uncontrolled - Tributary	
<b>Area (ha):</b> 0.19			
<b>C:</b> 1.00			

tc (min)	I (100 yr) (mm/hr)	Qactual (L/s)	Qrelease (L/s)	Qstored (L/s)	Vstored (m <sup>3</sup> )
10	178.56	94.3	94.3		
20	119.95	63.4	63.4		
30	91.87	48.5	48.5		
40	75.15	39.7	39.7		
50	63.95	33.8	33.8		
60	55.89	29.5	29.5		
70	49.79	26.3	26.3		
80	44.99	23.8	23.8		
90	41.11	21.7	21.7		
100	37.90	20.0	20.0		
110	35.20	18.6	18.6		
120	32.89	17.4	17.4		

<b>Subdrainage Area:</b> TANK 3		Uncontrolled - Tributary	
<b>Area (ha):</b> 0.05			
<b>C:</b> 0.81			

tc (min)	I (2 yr) (mm/hr)	Qactual (L/s)	Qrelease (L/s)	Qstored (L/s)	Vstored (m <sup>3</sup> )
10	76.81	8.6	8.6		
20	52.03	5.9	5.9		
30	40.04	4.5	4.5		
40	32.86	3.7	3.7		
50	28.04	3.2	3.2		
60	24.56	2.8	2.8		
70	21.91	2.5	2.5		
80	19.83	2.2	2.2		
90	18.14	2.0	2.0		
100	16.75	1.9	1.9		
110	15.57	1.8	1.8		
120	14.56	1.6	1.6		

<b>Subdrainage Area:</b> TANK 3		Uncontrolled - Tributary	
<b>Area (ha):</b> 0.05			
<b>C:</b> 1.00			

tc (min)	I (100 yr) (mm/hr)	Qactual (L/s)	Qrelease (L/s)	Qstored (L/s)	Vstored (m <sup>3</sup> )
10	178.56	24.3	24.8		
20	119.95	16.7	16.7		
30	91.87	12.8	12.8		
40	75.15	10.4	10.4		
50	63.95	8.9	8.9		
60	55.89	7.8	7.8		
70	49.79	6.9	6.9		
80	44.99	6.3	6.3		
90	41.11	5.7	5.7		
100	37.90	5.3	5.3		
110	35.20	4.9	4.9		
120	32.89	4.6	4.6		

# Stormwater Management Calculations

## Project #160401536, 729 Ridgewood Avenue - Brigil Homes Modified Rational Method Calculators for Storage

Subdrainage Area: TANK 4 Uncontrolled - Tributary  
Area (ha): 0.15  
C: 0.22

tc (min)	I (2 yr) (mm/hr)	Qactual (L/s)	Qrelease (L/s)	Qstored (L/s)	Vstored (m <sup>3</sup> )
10	76.81	7.0	7.0		
20	52.03	4.8	4.8		
30	40.04	3.7	3.7		
40	32.86	3.0	3.0		
50	28.04	2.6	2.6		
60	24.56	2.3	2.3		
70	21.91	2.0	2.0		
80	19.83	1.8	1.8		
90	18.14	1.7	1.7		
100	16.75	1.5	1.5		
110	15.57	1.4	1.4		
120	14.56	1.3	1.3		

Subdrainage Area: TANK 5 Uncontrolled - Tributary  
Area (ha): 0.08  
C: 0.22

tc (min)	I (2 yr) (mm/hr)	Qactual (L/s)	Qrelease (L/s)	Qstored (L/s)	Vstored (m <sup>3</sup> )
10	76.81	3.8	3.8		
20	52.03	2.5	2.5		
30	40.04	2.0	2.0		
40	32.86	1.6	1.6		
50	28.04	1.4	1.4		
60	24.56	1.2	1.2		
70	21.91	1.1	1.1		
80	19.83	1.0	1.0		
90	18.14	0.9	0.9		
100	16.75	0.8	0.8		
110	15.57	0.8	0.8		
120	14.56	0.7	0.7		

Subdrainage Area: UNC-1 Uncontrolled - Non-Tributary (Ridgewood Avenue)  
Area (ha): 0.13  
C: 0.46

tc (min)	I (2 yr) (mm/hr)	Qactual (L/s)	Qrelease (L/s)	Qstored (L/s)	Vstored (m <sup>3</sup> )
10	76.81	12.8	12.8		
20	52.03	8.6	8.6		
30	40.04	6.7	6.7		
40	32.86	5.5	5.5		
50	28.04	4.7	4.7		
60	24.56	4.1	4.1		
70	21.91	3.6	3.6		
80	19.83	3.3	3.3		
90	18.14	3.0	3.0		
100	16.75	2.8	2.8		
110	15.57	2.6	2.6		
120	14.56	2.4	2.4		

Subdrainage Area: CISTERN Controlled - Tributary  
\*Accepts flows from TANK1-6, ROOF1-4

tc (min)	I (2 yr) (mm/hr)	Qactual (L/s)	Qrelease (L/s)	Qstored (L/s)	Vstored (m <sup>3</sup> )
10	76.81	94.1	94.1	0.0	0.0
20	52.03	70.5	70.5	0.0	0.0
30	40.04	58.6	58.6	0.0	0.0
40	32.86	51.1	51.1	0.0	0.0
50	28.04	45.8	45.8	0.0	0.0
60	24.56	41.8	41.8	0.0	0.0
70	21.91	38.7	38.7	0.0	0.0
80	19.83	36.1	36.1	0.0	0.0
90	18.14	33.9	33.9	0.0	0.0
100	16.75	32.0	32.0	0.0	0.0
110	15.57	30.3	30.3	0.0	0.0
120	14.56	28.8	28.8	0.0	0.0

Stage	Head (m)	Discharge (L/s)	Vreq (cu. m)	Vavail (cu. m)	Volume Check
5-year Water Level		94.1	0.0	50.0	OK

### SUMMARY TO OUTLET

	Tributary Area	1.20 ha	Vrequired	Vavailable*
Total 2yr Flow to Sewer	94.1 L/s		0	0 m <sup>3</sup> OK
Total 2yr Flow Uncontrolled	12.8 L/s			
Total Area	1.33 ha			
Total 2yr Flow Target	106.8 L/s			
	203.3 L/s			

## Project #160401536, 729 Ridgewood Avenue - Brigil Homes Modified Rational Method Calculators for Storage

Subdrainage Area: TANK 4 Uncontrolled - Tributary  
Area (ha): 0.15  
C: 0.28

tc (min)	I (100 yr) (mm/hr)	Qactual (L/s)	Qrelease (L/s)	Qstored (L/s)	Vstored (m <sup>3</sup> )
10	178.56	20.5	20.5		
20	119.95	13.8	13.8		
30	91.87	10.5	10.5		
40	75.15	8.6	8.6		
50	63.95	7.3	7.3		
60	55.89	6.4	6.4		
70	49.79	5.7	5.7		
80	44.99	5.2	5.2		
90	41.11	4.7	4.7		
100	37.90	4.3	4.3		
110	35.20	4.0	4.0		
120	32.89	3.8	3.8		

Subdrainage Area: TANK 5 Uncontrolled - Tributary  
Area (ha): 0.08  
C: 0.28

tc (min)	I (100 yr) (mm/hr)	Qactual (L/s)	Qrelease (L/s)	Qstored (L/s)	Vstored (m <sup>3</sup> )
10	178.56	10.9	10.9		
20	119.95	7.3	7.3		
30	91.87	5.6	5.6		
40	75.15	4.6	4.6		
50	63.95	3.9	3.9		
60	55.89	3.4	3.4		
70	49.79	3.0	3.0		
80	44.99	2.8	2.8		
90	41.11	2.5	2.5		
100	37.90	2.3	2.3		
110	35.20	2.2	2.2		
120	32.89	2.0	2.0		

Subdrainage Area: UNC-1 Uncontrolled - Non-Tributary (Ridgewood Avenue)  
Area (ha): 0.13  
C: 0.58

tc (min)	I (100 yr) (mm/hr)	Qactual (L/s)	Qrelease (L/s)	Qstored (L/s)	Vstored (m <sup>3</sup> )
10	178.56	37.1	37.1		
20	119.95	24.9	24.9		
30	91.87	19.1	19.1		
40	75.15	15.6	15.6		
50	63.95	13.3	13.3		
60	55.89	11.6	11.6		
70	49.79	10.3	10.3		
80	44.99	9.3	9.3		
90	41.11	8.5	8.5		
100	37.90	7.9	7.9		
110	35.20	7.3	7.3		
120	32.89	6.8	6.8		

Subdrainage Area: CISTERN Controlled - Tributary  
\*Accepts flows from TANK1-6, ROOF1-4

tc (min)	I (100 yr) (mm/hr)	Qactual (L/s)	Qrelease (L/s)	Qstored (L/s)	Vstored (m <sup>3</sup> )
10	178.56	244.8	166.2	78.6	47.2
20	119.95	174.4	166.2	8.2	9.8
30	91.87	140.4	140.4	0.0	0.0
40	75.15	120.0	120.0	0.0	0.0
50	63.95	106.1	106.1	0.0	0.0
60	55.89	96.0	96.0	0.0	0.0
70	49.79	88.3	88.3	0.0	0.0
80	44.99	82.0	82.0	0.0	0.0
90	41.11	76.9	76.9	0.0	0.0
100	37.90	72.6	72.6	0.0	0.0
110	35.20	68.9	68.9	0.0	0.0
120	32.89	65.7	65.7	0.0	0.0

Stage	Head (m)	Discharge (L/s)	Vreq (cu. m)	Vavail (cu. m)	Volume Check
100-year Water Level		166.2	47.2	50.0	OK

2.85

### SUMMARY TO OUTLET

	Tributary Area	1.20 ha	Vrequired	Vavailable*
Total 100yr Flow to Sewer	166.2 L/s		0	0 m <sup>3</sup> OK
Total 100yr Flow Uncontrolled	37.1 L/s			
Total Area	1.33 ha			
Total 100yr Flow Target	203.3 L/s			
	203.3 L/s			

**Roof Drain Design Calculation Sheet**

**Project #160401536, 729 Ridgewood Avenue - Brigil Homes**  
**Roof Drain Design Sheet, Area ROOF\_1**  
**Standard Zurn Model Z-105-5 Control-Flo Single Notch Roof Drain**

Rating Curve				Volume Estimation				Water Depth (m)
Elevation (m)	Discharge Rate (cu.m/s)	Outlet Discharge (cu.m/s)	Storage (cu. m)	Elevation (m)	Area (sq. m)	Volume (cu. m)		
						Increment	Accumulated	
0.000	0.0000	0.0000	0	0.000	0	0	0	0.000
0.025	0.0003	0.0013	0	0.025	20	0	0	0.025
0.050	0.0006	0.0025	1	0.050	80	1	1	0.050
0.075	0.0008	0.0032	5	0.075	180	3	5	0.075
0.100	0.0009	0.0038	11	0.100	320	6	11	0.100
0.125	0.0011	0.0044	21	0.125	500	10	21	0.125
0.150	0.0013	0.0050	36	0.150	720	15	36	0.150

Drawdown Estimate			
Total Volume (cu.m)	Total Time (sec)	Vol (cu.m)	Detention Time (hr)
0.0	0.0	0.0	0
1.2	462.3	1.2	0.12842
4.3	1003.9	3.2	0.40727
10.5	1629.1	6.2	0.85978
20.7	2302.1	10.2	1.49925
35.8	3005.0	15.2	2.33396

**Rooftop Storage Summary**

Total Building Area (sq.m)		900	
Assume Available Roof Area (sq. Roof Imperviousness)	80%	720	
		0.99	
Number of Roof Notches*		4	
Max. Allowable Depth of Roof Ponding (m)		0.15	* As per Ontario Building Code section OBC 7.4.10.4.(2)(c).
Max. Allowable Storage (cu.m)		36	
Estimated 100 Year Drawdown Time (h)		2.2	

**From Watts Drain Catalogue**

Head (m) L/s					
	Open	75%	50%	25%	Closed
0.025	0.3155	0.3155	0.3155	0.3155	0.3155
0.050	0.6309	0.6309	0.6309	0.6309	0.6309
0.075	0.9464	0.8675	0.7886	0.7098	0.6309
0.100	1.2618	1.1041	0.9464	0.7886	0.6309
0.125	1.5773	1.3407	1.1041	0.8675	0.6309
0.150	1.8927	1.5773	1.2618	0.9464	0.6309

\* Note: Number of drains can be reduced if multiple-notch drain used.

**Calculation Results**

	5yr	100yr	Available
Qresult (cu.m/s)	0.004	0.005	-
Depth (m)	0.096	0.146	0.150
Volume (cu.m)	9.6	33.3	36.0
Drain time (hrs)	0.8	2.2	

**Roof Drain Design Calculation Sheet**

**Project #160401536, 729 Ridgewood Avenue - Brigil Homes**  
**Roof Drain Design Sheet, Area ROOF\_2**  
**Standard Zurn Model Z-105-5 Control-Flo Single Notch Roof Drain**

Rating Curve				Volume Estimation				Water Depth (m)
Elevation (m)	Discharge Rate (cu.m/s)	Outlet Discharge (cu.m/s)	Storage (cu. m)	Elevation (m)	Area (sq. m)	Volume (cu. m)		
						Increment	Accumulated	
0.000	0.0000	0.0000	0	0.000	0	0	0	0.000
0.025	0.0003	0.0013	0	0.025	29	0	0	0.025
0.050	0.0006	0.0025	2	0.050	116	2	2	0.050
0.075	0.0009	0.0038	7	0.075	260	5	7	0.075
0.100	0.0013	0.0050	15	0.100	462	9	15	0.100
0.125	0.0016	0.0063	30	0.125	722	15	30	0.125
0.150	0.0019	0.0076	52	0.150	1040	22	52	0.150

Drawdown Estimate			
Total Volume (cu.m)	Total Time (sec)	Vol (cu.m)	Detention Time (hr)
0.0	0.0	0.0	0
1.7	667.8	1.7	0.18549
6.3	1208.3	4.6	0.52114
15.2	1764.8	8.9	1.01137
29.9	2327.6	14.7	1.65794
51.8	2893.7	21.9	2.46173

**Rooftop Storage Summary**

Total Building Area (sq.m)		1300	
Assume Available Roof Area (sq. Roof Imperviousness)	80%	1040	0.99
Number of Roof Notches*		4	
Max. Allowable Depth of Roof Ponding (m)		0.15	* As per Ontario Building Code section OBC 7.4.10.4.(2)(c).
Max. Allowable Storage (cu.m)		52	
Estimated 100 Year Drawdown Time (h)		1.5	

**From Watts Drain Catalogue**

Head (m)	L/s	75%	50%	25%	Closed
0.025	0.3155	0.3155	0.3155	0.3155	0.3155
0.050	0.6309	0.6309	0.6309	0.6309	0.6309
0.075	0.9464	0.8675	0.7886	0.7098	0.6309
0.100	1.2618	1.1041	0.9464	0.7886	0.6309
0.125	1.5773	1.3407	1.1041	0.8675	0.6309
0.150	1.8927	1.5773	1.2618	0.9464	0.6309

\* Note: Number of drains can be reduced if multiple-notch drain used.

Calculation Results	5yr	100yr	Available
Qresult (cu.m/s)	0.004	0.006	-
Depth (m)	0.074	0.117	0.150
Volume (cu.m)	6.3	25.2	52.0
Draintime (hrs)	0.5	1.5	

**Roof Drain Design Calculation Sheet**

**Project #160401536, 729 Ridgewood Avenue - Brigil Homes**  
**Roof Drain Design Sheet, Area ROOF\_3**  
**Standard Zurn Model Z-105-5 Control-Flo Single Notch Roof Drain**

Rating Curve				Volume Estimation				Water Depth (m)
Elevation (m)	Discharge Rate (cu.m/s)	Outlet Discharge (cu.m/s)	Storage (cu. m)	Elevation (m)	Area (sq. m)	Volume (cu. m)		
						Increment	Accumulated	
0.000	0.0000	0.0000	0	0.000	0	0	0	0.000
0.025	0.0003	0.0019	0	0.025	38	0	0	0.025
0.050	0.0006	0.0038	3	0.050	151	2	3	0.050
0.075	0.0009	0.0052	9	0.075	340	6	9	0.075
0.100	0.0011	0.0066	20	0.100	604	12	20	0.100
0.125	0.0013	0.0080	39	0.125	944	19	39	0.125
0.150	0.0016	0.0095	68	0.150	1360	29	68	0.150

Drawdown Estimate			
Total Volume (cu.m)	Total Time (sec)	Vol (cu.m)	Detention Time (hr)
0.0	0.0	0.0	0
2.2	582.2	2.2	0.16171
8.2	1149.2	6.0	0.48093
19.8	1758.4	11.6	0.96936
39.0	2387.3	19.2	1.63251
67.7	3027.2	28.6	2.4734

**Rooftop Storage Summary**

Total Building Area (sq.m)		1700	
Assume Available Roof Area (sq. Roof Imperviousness)	80%	1360	
		0.99	
Number of Roof Notches*		6	
Max. Allowable Depth of Roof Ponding (m)		0.15	* As per Ontario Building Code section OBC 7.4.10.4.(2)(c).
Max. Allowable Storage (cu.m)		68	
Estimated 100 Year Drawdown Time (h)		2.3	

**From Watts Drain Catalogue**

Head (m) L/s	Open	75%	50%	25%	Closed
0.025	0.3155	0.3155	0.3155	0.3155	0.3155
0.050	0.6309	0.6309	0.6309	0.6309	0.6309
0.075	0.9464	0.8675	0.7886	0.7098	0.6309
0.100	1.2618	1.1041	0.9464	0.7886	0.6309
0.125	1.5773	1.3407	1.1041	0.8675	0.6309
0.150	1.8927	1.5773	1.2618	0.9464	0.6309

\* Note: Number of drains can be reduced if multiple-notch drain used.

**Calculation Results**

	5yr	100yr	Available
Qresult (cu.m/s)	0.006	0.009	-
Depth (m)	0.098	0.146	0.150
Volume (cu.m)	19.0	63.1	68.0
Draintime (hrs)	0.9	2.3	

**Roof Drain Design Calculation Sheet**

**Project #160401536, 729 Ridgewood Avenue - Brigil Homes**  
**Roof Drain Design Sheet, Area ROOF 4**  
**Standard Zurn Model Z-105-5 Control-Flo Single Notch Roof Drain**

Rating Curve				Volume Estimation				Water Depth (m)
Elevation (m)	Discharge Rate (cu.m/s)	Outlet Discharge (cu.m/s)	Storage (cu. m)	Elevation (m)	Area (sq. m)	Volume (cu. m)		
						Increment	Accumulated	
0.000	0.0000	0.0000	0	0.000	0	0	0	0.000
0.025	0.0003	0.0013	0	0.025	33	0	0	0.025
0.050	0.0006	0.0025	2	0.050	133	2	2	0.050
0.075	0.0009	0.0038	8	0.075	300	5	8	0.075
0.100	0.0013	0.0050	18	0.100	533	10	18	0.100
0.125	0.0016	0.0063	35	0.125	833	17	35	0.125
0.150	0.0019	0.0076	60	0.150	1200	25	60	0.150

Drawdown Estimate			
Total Volume (cu.m)	Total Time (sec)	Vol (cu.m)	Detention Time (hr)
0.0	0.0	0.0	0
1.9	770.5	1.9	0.21403
7.2	1394.2	5.3	0.60132
17.5	2036.3	10.3	1.16696
34.4	2685.7	16.9	1.91301
59.7	3338.8	25.3	2.84046

**Rooftop Storage Summary**

Total Building Area (sq.m)		1500
Assume Available Roof Area (sq. Roof Imperviousness)	80%	1200
		0.99
Number of Roof Notches*		4
Max. Allowable Depth of Roof Ponding (m)		0.15
Max. Allowable Storage (cu.m)		60
Estimated 100 Year Drawdown Time (h)		2.8

\* As per Ontario Building Code section OBC 7.4.10.4.(2)(c).

**From Watts Drain Catalogue**

Head (m)	L/s	75%	50%	25%	Closed
0.025	0.3155	0.3155	0.3155	0.3155	0.3155
0.050	0.6309	0.6309	0.6309	0.6309	0.6309
0.075	0.9464	0.8675	0.7886	0.7098	0.6309
0.100	1.2618	1.1041	0.9464	0.7886	0.6309
0.125	1.5773	1.3407	1.1041	0.8675	0.6309
0.150	1.8927	1.5773	1.2618	0.9464	0.6309

\* Note: Number of drains can be reduced if multiple-notch drain used.

**Calculation Results**

	5yr	100yr	Available
Qresult (cu.m/s)	0.005	0.007	-
Depth (m)	0.100	0.148	0.150
Volume (cu.m)	17.9	57.6	60.0
Drain time (hrs)	1.2	2.8	



# Stormceptor<sup>®</sup> EF Sizing Report

## STORMCEPTOR<sup>®</sup> ESTIMATED NET ANNUAL SEDIMENT (TSS) LOAD REDUCTION

06/30/2022

Province:	Ontario
City:	Ottawa
Nearest Rainfall Station:	OTTAWA CDA RCS
Climate Station Id:	6105978
Years of Rainfall Data:	20

Project Name:	Ridgewood
Project Number:	59000
Designer Name:	Dustin Thiffault
Designer Company:	Stantec Consulting Ltd.
Designer Email:	dustin.thiffault@stantec.com
Designer Phone:	613-724-4420
EOR Name:	
EOR Company:	
EOR Email:	
EOR Phone:	

Site Name:	Overall
Drainage Area (ha):	1.20
Runoff Coefficient 'c':	0.66
Particle Size Distribution:	Fine
Target TSS Removal (%):	80.0

Required Water Quality Runoff Volume Capture (%):	90.00
Estimated Water Quality Flow Rate (L/s):	25.56
Oil / Fuel Spill Risk Site?	Yes
Upstream Flow Control?	Yes
Upstream Orifice Control Flow Rate to Stormceptor (L/s):	166.20
Peak Conveyance (maximum) Flow Rate (L/s):	
Site Sediment Transport Rate (kg/ha/yr):	

Net Annual Sediment (TSS) Load Reduction Sizing Summary	
Stormceptor Model	TSS Removal Provided (%)
EFO4	76
<b>EFO6</b>	<b>87</b>
EFO8	93
EFO10	96
EFO12	98

**Recommended Stormceptor EFO Model: EFO6**  
**Estimated Net Annual Sediment (TSS) Load Reduction (%): 87**  
**Water Quality Runoff Volume Capture (%): > 90**

## Stormceptor® EF Sizing Report

### THIRD-PARTY TESTING AND VERIFICATION

► **Stormceptor® EF and Stormceptor® EFO** are the latest evolutions in the Stormceptor® oil-grit separator (OGS) technology series, and are designed to remove a wide variety of pollutants from stormwater and snowmelt runoff. These technologies have been third-party tested in accordance with the Canadian ETV **Procedure for Laboratory Testing of Oil-Grit Separators** and performance has been third-party verified in accordance with the **ISO 14034 Environmental Technology Verification (ETV)** protocol.

### PERFORMANCE

► **Stormceptor® EF and EFO** remove stormwater pollutants through gravity separation and floatation, and feature a patent-pending design that generates positive removal of total suspended solids (TSS) throughout each storm event, including high-intensity storms. Captured pollutants include sediment, free oils, and sediment-bound pollutants such as nutrients, heavy metals, and petroleum hydrocarbons. Stormceptor is sized to remove a high level of TSS from the frequent rainfall events that contribute the vast majority of annual runoff volume and pollutant load. The technology incorporates an internal bypass to convey excessive stormwater flows from high-intensity storms through the device without resuspension and washout (scour) of previously captured pollutants. Proper routine maintenance ensures high pollutant removal performance and protection of downstream waterways.

### PARTICLE SIZE DISTRIBUTION (PSD)

► The **Canadian ETV PSD** shown in the table below was used, or in part, for this sizing. This is the identical PSD that is referenced in the Canadian ETV **Procedure for Laboratory Testing of Oil-Grit Separators** for both sediment removal testing and scour testing. The Canadian ETV PSD contains a wide range of particle sizes in the sand and silt fractions, and is considered reasonably representative of the particle size fractions found in typical urban stormwater runoff.

Particle Size (µm)	Percent Less Than	Particle Size Fraction (µm)	Percent
1000	100	500-1000	5
500	95	250-500	5
250	90	150-250	15
150	75	100-150	15
100	60	75-100	10
75	50	50-75	5
50	45	20-50	10
20	35	8-20	15
8	20	5-8	10
5	10	2-5	5
2	5	<2	5

## Stormceptor<sup>®</sup> EF Sizing Report

### Upstream Flow Controlled Results

Rainfall Intensity (mm / hr)	Percent Rainfall Volume (%)	Cumulative Rainfall Volume (%)	Flow Rate (L/s)	Flow Rate (L/min)	Surface Loading Rate (L/min/m <sup>2</sup> )	Removal Efficiency (%)	Incremental Removal (%)	Cumulative Removal (%)
0.5	8.6	8.6	1.10	66.0	25.0	100	8.6	8.6
1	20.3	29.0	2.20	132.0	50.0	100	20.3	29.0
2	16.2	45.2	4.40	264.0	100.0	96	15.6	44.5
3	12.0	57.2	6.61	396.0	151.0	89	10.7	55.3
4	8.4	65.6	8.81	528.0	201.0	83	7.0	62.3
5	5.9	71.6	11.01	661.0	251.0	81	4.8	67.1
6	4.6	76.2	13.21	793.0	301.0	78	3.6	70.7
7	3.1	79.3	15.41	925.0	352.0	76	2.3	73.0
8	2.7	82.0	17.61	1057.0	402.0	74	2.0	75.1
9	3.3	85.3	19.82	1189.0	452.0	72	2.4	77.4
10	2.3	87.6	22.02	1321.0	502.0	69	1.6	79.0
11	1.6	89.2	24.22	1453.0	553.0	67	1.0	80.1
12	1.3	90.5	26.42	1585.0	603.0	65	0.9	80.9
13	1.7	92.2	28.62	1717.0	653.0	64	1.1	82.0
14	1.2	93.5	30.82	1849.0	703.0	64	0.8	82.8
15	1.2	94.6	33.03	1982.0	753.0	63	0.7	83.6
16	0.7	95.3	35.23	2114.0	804.0	63	0.4	84.0
17	0.7	96.1	37.43	2246.0	854.0	63	0.5	84.5
18	0.4	96.5	39.63	2378.0	904.0	62	0.2	84.7
19	0.4	96.9	41.83	2510.0	954.0	62	0.3	85.0
20	0.2	97.1	44.04	2642.0	1005.0	62	0.1	85.1
21	0.5	97.5	46.24	2774.0	1055.0	60	0.3	85.4
22	0.2	97.8	48.44	2906.0	1105.0	59	0.1	85.5
23	1.0	98.8	50.64	3038.0	1155.0	58	0.6	86.1
24	0.3	99.1	52.84	3171.0	1206.0	57	0.2	86.3
25	0.9	100.0	55.04	3303.0	1256.0	56	0.5	86.8
30	0.9	100.9	66.05	3963.0	1507.0	49	0.5	87.2
35	-0.9	100.0	77.06	4624.0	1758.0	42	N/A	86.8
40	0.0	100.0	88.07	5284.0	2009.0	36	0.0	86.8
45	0.0	100.0	99.08	5945.0	2260.0	32	0.0	86.8
<b>Estimated Net Annual Sediment (TSS) Load Reduction =</b>								<b>87 %</b>

Climate Station ID: 6105978 Years of Rainfall Data: 20



## Stormceptor® EF Sizing Report

### RAINFALL DATA FROM OTTAWA CDA RCS RAINFALL STATION

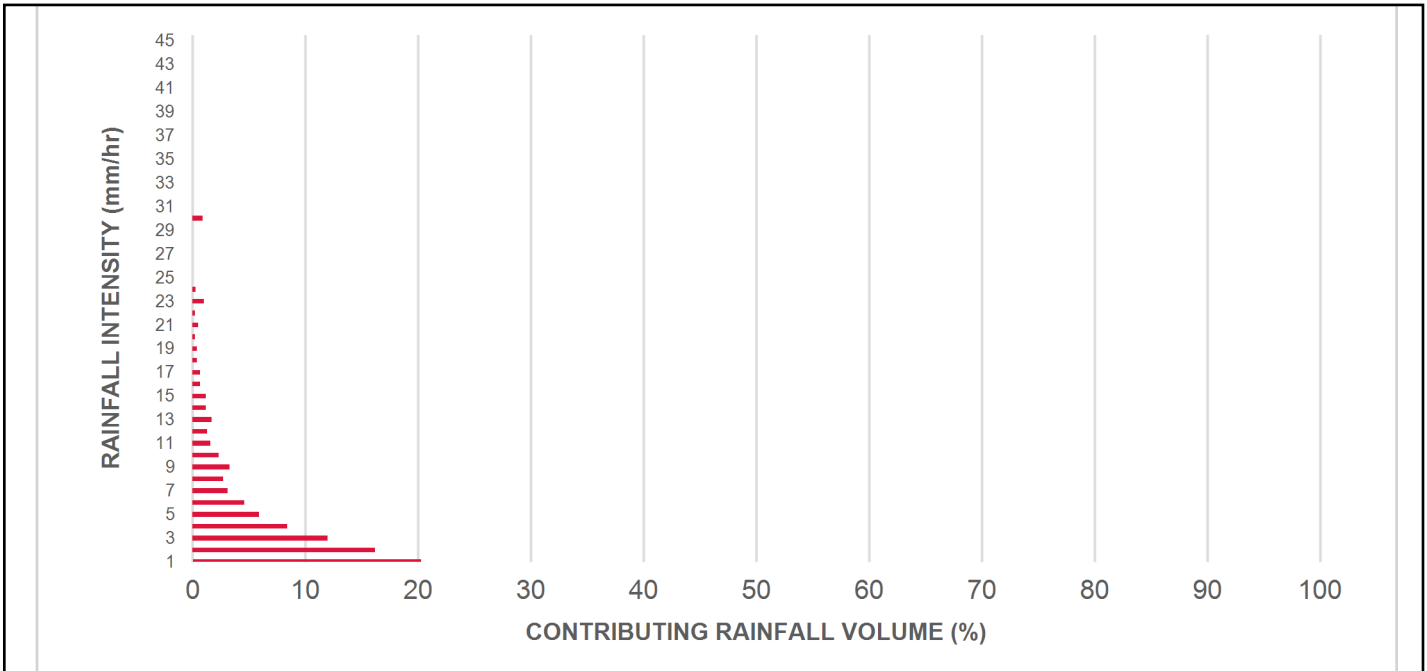

### INCREMENTAL AND CUMULATIVE TSS REMOVAL FOR THE RECOMMENDED STORMCEPTOR® MODEL

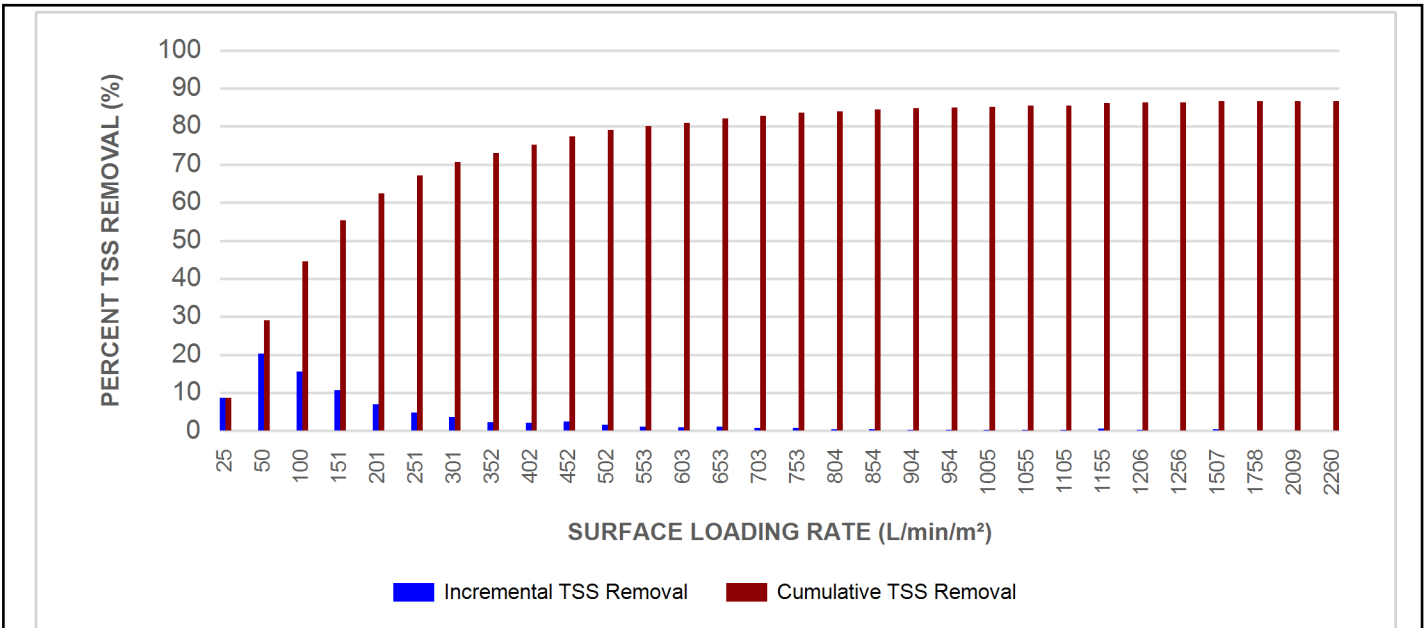

## Stormceptor® EF Sizing Report

### Maximum Pipe Diameter / Peak Conveyance

Stormceptor EF / EFO	Model Diameter		Min Angle Inlet / Outlet Pipes	Max Inlet Pipe Diameter		Max Outlet Pipe Diameter		Peak Conveyance Flow Rate	
	(m)	(ft)		(mm)	(in)	(mm)	(in)	(L/s)	(cfs)
EF4 / EFO4	1.2	4	90	609	24	609	24	425	15
EF6 / EFO6	1.8	6	90	914	36	914	36	990	35
EF8 / EFO8	2.4	8	90	1219	48	1219	48	1700	60
EF10 / EFO10	3.0	10	90	1828	72	1828	72	2830	100
EF12 / EFO12	3.6	12	90	1828	72	1828	72	2830	100

### SCOUR PREVENTION AND ONLINE CONFIGURATION

► Stormceptor® EF and EFO feature an internal bypass and superior scour prevention technology that have been demonstrated in third-party testing according to the scour testing provisions of the Canadian ETV **Procedure for Laboratory Testing of Oil-Grit Separators**, and the exceptional scour test performance has been third-party verified in accordance with the ISO 14034 ETV protocol. As a result, Stormceptor EF and EFO are approved for online installation, eliminating the need for costly additional bypass structures, piping, and installation expense.

### DESIGN FLEXIBILITY

► Stormceptor® EF and EFO offers design flexibility in one simplified platform, accepting stormwater flow from a single inlet pipe or multiple inlet pipes, and/or surface runoff through an inlet grate. The device can also serve as a junction structure, accommodate a 90-degree inlet-to-outlet bend angle, and can be modified to ensure performance in submerged conditions.

### OIL CAPTURE AND RETENTION

► While Stormceptor® EF will capture and retain oil from dry weather spills and low intensity runoff, Stormceptor® EFO has demonstrated superior oil capture and greater than 99% oil retention in third-party testing according to the light liquid re-entrainment testing provisions of the Canadian ETV **Procedure for Laboratory Testing of Oil-Grit Separators**. Stormceptor EFO is recommended for sites where oil capture and retention is a requirement.

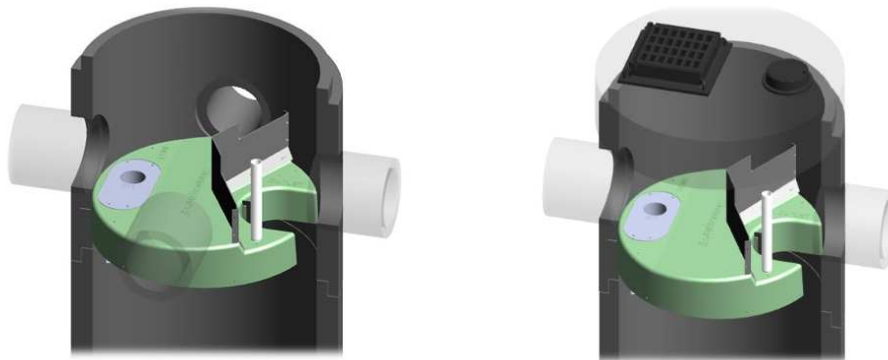

## Stormceptor® EF Sizing Report

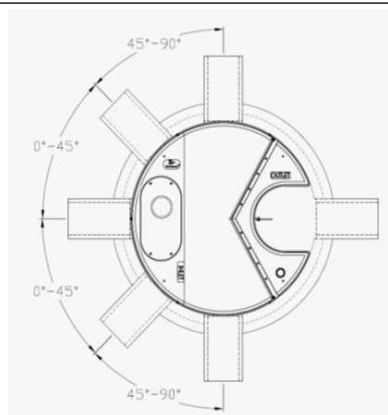

### INLET-TO-OUTLET DROP

Elevation differential between inlet and outlet pipe inverts is dictated by the angle at which the inlet pipe(s) enters the unit.

0° - 45° : The inlet pipe is 1-inch (25mm) higher than the outlet pipe.

45° - 90° : The inlet pipe is 2-inches (50mm) higher than the outlet pipe.

### HEAD LOSS

The head loss through Stormceptor EF is similar to that of a 60-degree bend structure. The applicable K value for calculating minor losses through the unit is 1.1.

For submerged conditions the applicable K value is 3.0.

### Pollutant Capacity

Stormceptor EF / EFO	Model Diameter		Depth (Outlet Pipe Invert to Sump Floor)		Oil Volume		Recommended Sediment Maintenance Depth *		Maximum Sediment Volume *		Maximum Sediment Mass **	
	(m)	(ft)	(m)	(ft)	(L)	(Gal)	(mm)	(in)	(L)	(ft <sup>3</sup> )	(kg)	(lb)
EF4 / EFO4	1.2	4	1.52	5.0	265	70	203	8	1190	42	1904	5250
EF6 / EFO6	1.8	6	1.93	6.3	610	160	305	12	3470	123	5552	15375
EF8 / EFO8	2.4	8	2.59	8.5	1070	280	610	24	8780	310	14048	38750
EF10 / EFO10	3.0	10	3.25	10.7	1670	440	610	24	17790	628	28464	78500
EF12 / EFO12	3.6	12	3.89	12.8	2475	655	610	24	31220	1103	49952	137875

\*Increased sump depth may be added to increase sediment storage capacity

\*\* Average density of wet packed sediment in sump = 1.6 kg/L (100 lb/ft<sup>3</sup>)

Feature	Benefit	Feature Appeals To
Patent-pending enhanced flow treatment and scour prevention technology	Superior, verified third-party performance	Regulator, Specifying & Design Engineer
Third-party verified light liquid capture and retention for EFO version	Proven performance for fuel/oil hotspot locations	Regulator, Specifying & Design Engineer, Site Owner
Functions as bend, junction or inlet structure	Design flexibility	Specifying & Design Engineer
Minimal drop between inlet and outlet	Site installation ease	Contractor
Large diameter outlet riser for inspection and maintenance	Easy maintenance access from grade	Maintenance Contractor & Site Owner

### STANDARD STORMCEPTOR EF/EFO DRAWINGS

For standard details, please visit <http://www.imbriumsystems.com/stormwater-treatment-solutions/stormceptor-ef>

### STANDARD STORMCEPTOR EF/EFO SPECIFICATION

For specifications, please visit <http://www.imbriumsystems.com/stormwater-treatment-solutions/stormceptor-ef>

## Stormceptor<sup>®</sup> EF Sizing Report

# STANDARD PERFORMANCE SPECIFICATION FOR “OIL GRIT SEPARATOR” (OGS) STORMWATER QUALITY TREATMENT DEVICE

## PART 1 – GENERAL

### 1.1 WORK INCLUDED

This section specifies requirements for selecting, sizing, and designing an underground Oil Grit Separator (OGS) device for stormwater quality treatment, with third-party testing results and a Statement of Verification in accordance with ISO 14034 Environmental Management – Environmental Technology Verification (ETV).

### 1.2 REFERENCE STANDARDS & PROCEDURES

ISO 14034:2016 Environmental management – Environmental technology verification (ETV)

Canadian Environmental Technology Verification (ETV) Program’s **Procedure for Laboratory Testing of Oil-Grit Separators**

### 1.3 SUBMITTALS

1.3.1 All submittals, including sizing reports & shop drawings, shall be submitted upon request with each order to the contractor then forwarded to the Engineer of Record for review and acceptance. Shop drawings shall detail all OGS components, elevations, and sequence of construction.

1.3.2 Alternative devices shall have features identical to or greater than the specified device, including: treatment chamber diameter, treatment chamber wet volume, sediment storage volume, and oil storage volume.

1.3.3 Unless directed otherwise by the Engineer of Record, OGS stormwater quality treatment product substitutions or alternatives submitted within ten days prior to project bid shall not be accepted. All alternatives or substitutions submitted shall be signed and sealed by a local registered Professional Engineer, based on the exact same criteria detailed in Section 3, in entirety, subject to review and approval by the Engineer of Record.

## PART 2 – PRODUCTS

### 2.1 OGS POLLUTANT STORAGE

The OGS device shall include a sump for sediment storage, and a protected volume for the capture and storage of petroleum hydrocarbons and buoyant gross pollutants. The minimum sediment & petroleum hydrocarbon storage capacity shall be as follows:

2.1.1	4 ft (1219 mm) Diameter OGS Units:	1.19 m <sup>3</sup> sediment / 265 L oil
	6 ft (1829 mm) Diameter OGS Units:	3.48 m <sup>3</sup> sediment / 609 L oil
	8 ft (2438 mm) Diameter OGS Units:	8.78 m <sup>3</sup> sediment / 1,071 L oil
	10 ft (3048 mm) Diameter OGS Units:	17.78 m <sup>3</sup> sediment / 1,673 L oil
	12 ft (3657 mm) Diameter OGS Units:	31.23 m <sup>3</sup> sediment / 2,476 L oil

## PART 3 – PERFORMANCE & DESIGN

### 3.1 GENERAL

The OGS stormwater quality treatment device shall be verified in accordance with ISO 14034:2016 Environmental management – Environmental technology verification (ETV). The OGS stormwater quality treatment device shall

## Stormceptor<sup>®</sup> EF Sizing Report

remove oil, sediment and gross pollutants from stormwater runoff during frequent wet weather events, and retain these pollutants during less frequent high flow wet weather events below the insert within the OGS for later removal during maintenance. The Manufacturer shall have at least ten (10) years of local experience, history and success in engineering design, manufacturing and production and supply of OGS stormwater quality treatment device systems, acceptable to the Engineer of Record.

### 3.2 SIZING METHODOLOGY

The OGS device shall be engineered, designed and sized to provide stormwater quality treatment based on treating a minimum of 90 percent of the average annual runoff volume and a minimum removal of an annual average 60% of the sediment (TSS) load based on the Particle Size Distribution (PSD) specified in the sizing report for the specified device. Sizing of the OGS shall be determined by use of a minimum ten (10) years of local historical rainfall data provided by Environment Canada. Sizing shall also be determined by use of the sediment removal performance data derived from the ISO 14034 ETV third-party verified laboratory testing data from testing conducted in accordance with the Canadian ETV protocol Procedure for Laboratory Testing of Oil-Grit Separators, as follows:

3.2.1 Sediment removal efficiency for a given surface loading rate and its associated flow rate shall be based on sediment removal efficiency demonstrated at the seven (7) tested surface loading rates specified in the protocol, ranging 40 L/min/m<sup>2</sup> to 1400 L/min/m<sup>2</sup>, and as stated in the ISO 14034 ETV Verification Statement for the OGS device.

3.2.2 Sediment removal efficiency for surface loading rates between 40 L/min/m<sup>2</sup> and 1400 L/min/m<sup>2</sup> shall be based on linear interpolation of data between consecutive tested surface loading rates.

3.2.3 Sediment removal efficiency for surface loading rates less than the lowest tested surface loading rate of 40 L/min/m<sup>2</sup> shall be assumed to be identical to the sediment removal efficiency at 40 L/min/m<sup>2</sup>. No extrapolation shall be allowed that results in a sediment removal efficiency that is greater than that demonstrated at 40 L/min/m<sup>2</sup>.

3.2.4 Sediment removal efficiency for surface loading rates greater than the highest tested surface loading rate of 1400 L/min/m<sup>2</sup> shall assume zero sediment removal for the portion of flow that exceeds 1400 L/min/m<sup>2</sup>, and shall be calculated using a simple proportioning formula, with 1400 L/min/m<sup>2</sup> in the numerator and the higher surface loading rate in the denominator, and multiplying the resulting fraction times the sediment removal efficiency at 1400 L/min/m<sup>2</sup>.

The OGS device shall also have sufficient annual sediment storage capacity as specified and calculated in Section 2.1.

### 3.3 CANADIAN ETV or ISO 14034 ETV VERIFICATION OF SCOUR TESTING

The OGS device shall have Canadian ETV or ISO 14034 ETV Verification of third-party scour testing conducted in accordance with the Canadian ETV Program's **Procedure for Laboratory Testing of Oil-Grit Separators**.

3.3.1 To be acceptable for on-line installation, the OGS device must demonstrate an average scour test effluent concentration less than 10 mg/L at each surface loading rate tested, up to and including 2600 L/min/m<sup>2</sup>.

### 3.4 LIGHT LIQUID RE-ENTRAINMENT SIMULATION TESTING

The OGS device shall have Canadian ETV or ISO 14034 ETV Verification of completed third-party Light Liquid Re-entrainment Simulation Testing in accordance with the Canadian ETV **Program's Procedure for Laboratory Testing of Oil-Grit Separators**, with results reported within the Canadian ETV or ISO 14034 ETV verification. This re-entrainment testing is conducted with the device pre-loaded with low density polyethylene (LDPE) plastic beads as a surrogate for light liquids such as oil and fuel. Testing is conducted on the same OGS unit tested for sediment removal to



## Stormceptor<sup>®</sup> EF Sizing Report

assess whether light liquids captured after a spill are effectively retained at high flow rates.

3.4.1 For an OGS device to be an acceptable stormwater treatment device on a site where vehicular traffic occurs and the potential for an oil or fuel spill exists, the OGS device must have reported verified performance results of greater than 99% cumulative retention of LDPE plastic beads for the five specified surface loading rates (ranging 200 L/min/m<sup>2</sup> to 2600 L/min/m<sup>2</sup>) in accordance with the Light Liquid Re-entrainment Simulation Testing within the Canadian ETV Program's **Procedure for Laboratory Testing of Oil-Grit Separators**. However, an OGS device shall not be allowed if the Light Liquid Re-entrainment Simulation Testing was performed with screening components within the OGS device that are effective at retaining the LDPE plastic beads, but would not be expected to retain light liquids such as oil and fuel.

**SITE SERVICING AND STORMWATER MANAGEMENT BRIEF – MOONEY’S BAY - 729  
RIDGEWOOD AVENUE, OTTAWA, ON**

Appendix E Geotechnical Report and Environmental Site Assessment

**Appendix E GEOTECHNICAL REPORT AND ENVIRONMENTAL  
SITE ASSESSMENT**



## **4.0 Observations**

### **4.1 Surface Conditions**

The subject property is presently occupied by two slab on grade commercial buildings. A former mechanical shop located on southeastern portion of the site was recently demolished. The area was backfilled with granular material. A parking lot and pavement structure covers the majority of the site. Some landscaped areas were noted along Ridgewood Avenue.

The ground surface across the subject site is relatively flat and slightly below grade from Ridgewood Avenue and the property to the west. The site is bordered to the west by a residential high rise structure, to the north and east by a residential and institutional development, and Ridgewood Avenue to the south.

### **4.2 Subsurface Profile**

#### **Overburden**

Generally, the subsurface profile encountered at the boreholes consist of asphaltic concrete overlying a fill layer consisting of crushed stone and silty sand. The fill layer is underlain by a stiff to hard layer of brown silty clay with sand seams. Glacial till was encountered below the above noted layers consisting of a compact to a very dense silty sand with clay, gravel, cobbles, and boulders. Seams of coarse sand were encountered in the glacial till layer at some test hole locations. Reference should be made to the Soil Profile and Test Data sheets in Appendix 1 for the details of the soil profile encountered at each test hole location.

#### **Bedrock**

Bedrock was cored at one borehole location to confirm refusal. Limestone bedrock was encountered at a depth of 9.7 m below the existing ground surface at BH6. Refusal was encountered in the other boreholes between a depth of 4.8 to 8.7 m. It should be noted that boulders are to be expected.

Upon review of the core hole sample, the upper first meter of the bedrock was found to be of good quality.

Based on available geological mapping, the subject site is located in an area where the bedrock consists of limestone of the Bobcaygeon Formation. The overburden drift thickness is anticipated to be between 5 to 15 m in depth.

### 4.3 Groundwater

Flexible piezometers were installed as part of our geotechnical investigation. Groundwater level measurements were recorded at the borehole locations and our findings are presented in Table 1. It should also be noted that the groundwater level is subject to seasonal fluctuations. Therefore, groundwater could vary at the time of construction. It should be further noted that groundwater measurements at monitoring well locations can be influenced by surface water entering the backfilled borehole, which can lead to higher than normal groundwater level readings. Long-term groundwater levels can also be determined based on observations of the recovered soil samples, such as moisture levels, colouring and consistency. Based on these observations, the long-term groundwater level is expected at a 5 to 6 m depth.

<b>Table 1 - Groundwater Measurements at Monitoring Well Locations</b>				
<b>Test Hole Location</b>	<b>Ground Surface Elevation (m)</b>	<b>GW Level Reading (m)</b>	<b>GW Level Elevation (m)</b>	<b>Date</b>
BH 1	82.55	2.75	79.80	July 7, 2020
BH 2	81.92	3.54	78.38	July 7, 2020
BH 3	82.05	4.72	77.33	July 7, 2020
BH 4	81.35	4.01	77.34	July 7, 2020
BH 5	81.71	3.28	78.43	July 7, 2020
BH 6	82.02	1.88	80.14	July 7, 2020
BH 7	81.61	3.15	78.46	July 7, 2020

## 5.0 Discussion

### 5.1 Geotechnical Assessment

From a geotechnical perspective, the subject site is considered satisfactory for the proposed development. The proposed mid-rise residential building is anticipated to be founded on spread footings placed directly or indirectly by the use of a lean concrete in-filled trench on a clean, surface sounded bedrock bearing surface or compact glacial till bearing surface.

Bedrock removal may be required to complete the underground level. Hoe ramming is an option where only small quantities of bedrock need to be removed. Line drilling and controlled blasting where large quantities of bedrock need to be removed is recommended. The blasting operations should be planned and completed under the guidance of a professional engineer with experience in blasting operations.

The above and other considerations are further discussed in the following sections.

### 5.2 Site Grading and Preparation

#### Stripping Depth

Since the building will occupy the entire boundaries of the subject site, it is expected that most of the overburden will be removed to bedrock. Topsoil and deleterious fill, such as those containing organic materials, should be stripped from under any buildings, paved areas, pipe bedding and other settlement sensitive structures

#### Bedrock Removal

Bedrock removal can be accomplished by hoe ramming where only small quantity of the bedrock needs to be removed. Sound bedrock may be removed by line drilling and controlled blasting and/or hoe ramming.

Prior to considering blasting operations, the blasting effects on the existing services, buildings and other structures should be addressed. A pre-blast or pre-construction survey of the existing structures located in proximity of the blasting operations should be completed prior to commencing site activities. The extent of the survey should be determined by the blasting consultant and should be sufficient to respond to any inquiries/claims related to the blasting operations.

As a general guideline, peak particle velocities (measured at the structures) should not exceed 25 mm/s during the blasting program to reduce the risks of damage to the existing structures. The blasting operations should be planned and conducted under the supervision of a licensed professional engineer who is also an experienced blasting consultant.

Excavation side slopes in sound bedrock can be carried out using almost vertical side walls. A minimum 1 m horizontal ledge, should be left between the bottom of the overburden excavation and the top of the bedrock surface to provide an area to allow for potential sloughing or to provide a stable base for the overburden shoring system.

### **Lean Concrete In-Filled Trenches**

Where bedrock is encountered below the design underside of footing elevation, consideration should be given to excavating vertical trenches to expose the underlying bedrock surface and backfilling with lean concrete (15 MPa 28-day compressive strength). Typically, the excavation sidewalls will be used as the form to support the concrete. The additional width of the concrete poured against an undisturbed trench sidewall will suffice in providing a direct transfer of the footing load to the underlying bedrock.

The effectiveness of this operation will depend on the ability of maintaining vertical trenches until the lean concrete can be poured. It is suggested that once the bottom of the excavation is exposed, an assessment should be completed to determine the water infiltration and stability of the excavation sidewalls extending to the bedrock surface.

The trench excavation should be at least 150 mm wider than all sides of the footing at the base of the excavation. The excavation bottom should be relatively clean using the hydraulic shovel only (workers will not be permitted in the excavation below a 1.5 m depth). Once approved by the geotechnical engineer, lean concrete can be poured up to the proposed founding elevation.

Footings placed on lean concrete filled trenches extending to the bedrock surface can be designed using a factored bearing resistance value at ultimate limit states (ULS) of 1,500 kPa.

## **Vibration Considerations**

Construction operations are the cause of vibrations, and possibly, sources of nuisance to the community. Therefore, means to reduce the vibration levels as much as possible should be incorporated in the construction operations to maintain, as much as possible, a cooperative environment with the residents.

The following construction equipments could be the source of vibrations: hoe ram, compactor, dozer, crane, truck traffic, etc. Vibrations, whether caused by blasting operations or by construction operations, could be the source of detrimental vibrations on the nearby buildings and structures. Therefore, all vibrations are recommended to be limited.

Two parameters are used to determine the permissible vibrations, namely, the maximum peak particle velocity and the frequency. For low frequency vibrations, the maximum allowable peak particle velocity is less than that for high frequency vibrations. As a guideline, the peak particle velocity should be less than 15 mm/s between frequencies of 4 to 12 Hz, and 50 mm/s above a frequency of 40 Hz (interpolate between 12 and 40 Hz). The guidelines are for current construction standards. Considering that these guidelines are above perceptible human level and, in some cases, could be very disturbing to some people, a pre-construction survey is recommended be completed to minimize the risks of claims during or following the construction of the proposed building.

## **Fill Placement**

Fill used for grading purposes beneath the proposed buildings should consist of clean imported granular fill, such as Ontario Provincial Standard Specifications (OPSS) Granular A or Granular B Type II. The fill should be tested and approved prior to delivery to the site. It should be placed in lifts no greater than 300 mm in thickness and compacted using suitable compaction equipment for the specified lift thickness. Fill placed beneath the building areas should be compacted to at least 98% of its standard Proctor maximum dry density (SPMDD).

Non-specified existing fill along with site-excavated soil can be used as general landscaping fill where settlement of the ground surface is of minor concern. These materials should be spread in thin lifts and be compacted at minimum by the tracks of the spreading equipment to minimize voids. If these materials are to be used to build up the subgrade level for areas to be paved, they should be compacted in thin lifts to a minimum density of 95% of their respective SPMDD. Non-specified existing fill and site-excavated soils are not suitable for use as backfill against foundation walls unless used in conjunction with a composite drainage membrane.

## 5.3 Foundation Design

### Bearing Resistance Values

Footings placed on an undisturbed, **dense glacial till bearing surface** can be designed using a bearing resistance value at serviceability limit states (SLS) of **250 kPa** and a factored bearing resistance value at ultimate limit states (ULS) of **500 kPa**. A geotechnical resistance factor of 0.5 was applied to the above noted bearing resistance value at ULS. Footings designed using the above-noted bearing resistance value at SLS will be subjected to potential post-construction total and differential settlements of 25 and 20 mm, respectively.

Footings placed on the upper levels of the **fractured limestone** bedrock bearing surface can be designed using a factored bearing resistance value at ultimate limit states (ULS) of **1,500 kPa**, incorporating a geotechnical resistance factor of 0.5. Where the design underside of footing is slightly above the bedrock surface, footings can be placed over concrete in-filled (17 MPa). zero entry, near vertical trenches extended to a surface sounded bedrock bearing surface using the same bearing resistance values. The concrete in-filled trenches should extend a minimum 300 mm beyond the footing faces in all directions.

A factored bearing resistance value at ULS of **4,000 kPa**, incorporating a geotechnical resistance factor of 0.5 if founded on **clean, surface sounded limestone bedrock** and the bedrock is free of seams, fractures and voids within 1.5 m below the founding level. This could be verified by completing and probing 50 mm diameter drill holes to a depth of 1.5 m below the founding level within the footing footprint(s). One drill hole should be completed per footing. The drill hole inspection should be completed by the geotechnical consultant.

A clean, surface-sounded bedrock bearing surface should be free of loose materials, and have no near surface seams, voids, fissures or open joints which can be detected from surface sounding with a rock hammer.

Footings bearing on an acceptable bedrock bearing surface and designed using the bearing resistance values provided herein will be subjected to negligible potential post-construction total and differential settlements.



## Soil/Bedrock Transition

It is expected that not all footings will be founded on bedrock. Where the building is founded on the glacial till deposit, it is recommended to decrease the soil bearing capacity by 25% for the footing placed on soil bearing media to reduce the potential long term total and differential settlements. Also, at the soil/bedrock and bedrock/soil transitions, it is recommended that a 2 m transition zone composed of 0.5 m layer of nominally compacted OPSS Granular A or Granular B type II be placed directly on sound bedrock. Steel reinforcement, extending at least 3 m on both sides of the 2 m long transition should be placed in the top part of the footing and foundation walls.

## Raft Foundation

Alternatively, consideration can be given to a raft foundation if the building loads exceed the bearing resistance values provided for a conventional spread footing foundation. The following parameters may be used for raft design.

The amount of settlement of the raft slab will be dependent on the sustained raft contact pressure. The bearing resistance value at SLS (contact pressure) of **250 kPa** can be used for design purposes. The loading conditions for the contact pressure are based on sustained loads, that are generally taken to be 100% Dead Load and 50% Live Load. The contact pressure provided considers the stress relief associated with the soil removal associated with one underground parking level. The factored bearing resistance (contact pressure) at ULS can be taken as **400 kPa**. A geotechnical resistance factor of 0.5 was applied to the bearing resistance value at ULS.

Based on the following assumptions for the raft foundation, the proposed building can be designed using the above parameters with a total and differential settlement of 25 and 15 mm, respectively.

Base on a single underground parking level or more it is expected that the raft foundation will be installed on the glacial till deposit. The modulus of subgrade reaction was calculated to be **30 MPa/m** for a contact pressure of 250 kPa. The design of the raft foundation is required to consider the relative stiffness of the reinforced concrete slab and the supporting bearing medium.

## Lateral Support

The bearing medium under footing-supported structures is required to be provided with adequate lateral support with respect to excavations and different foundation levels. Adequate lateral support is provided to a sound bedrock bearing medium when a plane extending down and out from the bottom edge of the footing at a minimum of 1H:6V (or flatter) passes only through sound bedrock or a material of the same or higher capacity as the bedrock, such as concrete. A weathered bedrock bearing medium will require a lateral support zone of 1H:1V (or flatter).

## 5.4 Design for Earthquakes

The site class for seismic site response can be taken as **Class C** for the foundations considered at this site. However, a higher site class (**Class A or B**) can be achieved. The higher site class will require a site specific shear wave velocity test to be completed in confirmation of the seismic site classification. The soils underlying the subject site are not susceptible to liquefaction. Refer to the latest revision of the Ontario Building Code for a full discussion of the earthquake design requirements.

## 5.5 Basement Slab

With the removal of all topsoil and deleterious fill, containing organic matter, within the footprints of the proposed building, the native soil surface, bedrock or approved engineered fill pad will be considered an acceptable subgrade on which to commence backfilling for floor slab construction.

Any soft areas should be removed and backfilled with appropriate backfill material. A clear crushed stone fill is recommended for backfilling below the floor slab for limited span slab-on-grade areas, such as front porch or garage footprints. It is recommended that the upper 200 mm of sub-slab fill consist of 19 mm clear crushed stone below basement floor slabs.

It is expected that the basement area will be mostly parking and a rigid pavement structure designed by a structural engineer will be applicable. However, if storage or other uses of the lower level where a concrete floor slab will be used it is recommended that the upper 200 mm of sub-slab fill consists of 19 mm clear crushed stone. All backfill material within the footprint of the proposed building should be placed in maximum 300 mm thick loose layers and compacted to at least 98% of its SPMDD.

## 5.6 Basement Wall

It is understood that the basement walls are to be poured against a dampproofing system, which will be placed against the exposed bedrock face. Below the bedrock surface, a nominal coefficient for at-rest earth pressure of 0.01 is recommended in conjunction with a bulk unit weight of 24.5 kN/m<sup>3</sup> (effective 15.5 kN/m<sup>3</sup>). A seismic earth pressure component will not be applicable for the foundation wall, which is to be poured against the bedrock face. It is expected that the seismic earth pressure will be transferred to the underground floor slabs, which should be designed to accommodate these pressures. A hydrostatic groundwater pressure should be added for the portion below the groundwater level.

Where soil is to be retained, the conditions can be well-represented by assuming the retained soil consists of a material with an angle of internal friction of 30 degrees and a bulk (drained) unit weight of 20 kN/m<sup>3</sup>. Undrained conditions are anticipated (i.e. below the groundwater level). Therefore, the applicable effective (undrained) unit weight of the retained soil can be taken as 13 kN/m<sup>3</sup>, where applicable. A hydrostatic pressure should be added to the total static earth pressure when using the effective unit weight.

Two distinct conditions, static and seismic, must be reviewed for design calculations. The parameters for design calculations for the two conditions are presented below.

### Static Conditions

The static horizontal earth pressure ( $p_o$ ) can be calculated using a triangular earth pressure distribution equal to  $K_o \cdot \gamma \cdot H$  where:

- $K_o$  = at-rest earth pressure coefficient of the applicable retained soil, 0.5
- $\gamma$  = unit weight of fill of the applicable retained soil (kN/m<sup>3</sup>)
- $H$  = height of the wall (m)

An additional pressure having a magnitude equal to  $K_o \cdot q$  and acting on the entire height of the wall should be added to the above diagram for any surcharge loading,  $q$  (kPa), that may be placed at ground surface adjacent to the wall. The surcharge pressure will only be applicable for static analyses and should not be used in conjunction with the seismic loading case.

Actual earth pressures could be higher than the “at-rest” case if care is not exercised during the compaction of the backfill materials to maintain a minimum separation of 0.3 m from the walls with the compaction equipment.

## Seismic Conditions

The total seismic force ( $P_{AE}$ ) includes both the earth force component ( $P_o$ ) and the seismic component ( $\Delta P_{AE}$ ).

The seismic earth force ( $\Delta P_{AE}$ ) can be calculated using  $0.375 \cdot a_c \cdot \gamma \cdot H^2/g$  where:

$$a_c = (1.45 - a_{max}/g) a_{max}$$

$\gamma$  = unit weight of fill of the applicable retained soil (kN/m<sup>3</sup>)

H = height of the wall (m)

g = gravity, 9.81 m/s<sup>2</sup>

The peak ground acceleration, ( $a_{max}$ ), for the Ottawa area is 0.32g according to OBC 2012. Note that the vertical seismic coefficient is assumed to be zero.

The earth force component ( $P_o$ ) under seismic conditions can be calculated using  $P_o = 0.5 K_o \gamma H^2$ , where  $K_o = 0.5$  for the soil conditions noted above.

The total earth force ( $P_{AE}$ ) is considered to act at a height, h (m), from the base of the wall, where:

$$h = \{P_o \cdot (H/3) + \Delta P_{AE} \cdot (0.6 \cdot H)\} / P_{AE}$$

The earth forces calculated are unfactored. For the ULS case, the earth loads should be factored as live loads, as per OBC 2012.

## 5.7 Pavement Structure

For design purposes, the flexible pavement structure presented in the following table could be used for the design of car only parking areas in the lower level of the parking garage.

<b>Table 4 - Recommended Pavement Structure - Parking Areas</b>	
<b>Thickness (mm)</b>	<b>Material Description</b>
50	<b>Wear Course</b> - HL 3 or Superpave 12.5 Asphaltic Concrete
150	<b>BASE</b> - OPSS Granular A Crushed Stone
300	<b>SUBBASE</b> - OPSS Granular B Type II
<b>SUBGRADE</b> - Either fill, in situ silty clay or sand or crushed stone material placed over in situ soil.	

<b>Table 5 - Recommended Pavement Structure - Local Roadways, Access Lanes and Heavy Vehicle Parking</b>	
<b>Thickness (mm)</b>	<b>Material Description</b>
40	<b>Wear Course</b> - Superpave 12.5 Asphaltic Concrete
50	<b>Binder Course</b> - Superpave 19.0 Asphaltic Concrete
150	<b>BASE</b> - OPSS Granular A Crushed Stone
400	<b>SUBBASE</b> - OPSS Granular B Type II
<b>SUBGRADE</b> - Either fill, in situ silty clay or sand or crushed stone material placed over in situ soil.	

Minimum Performance Graded (PG) 58-34 asphalt cement should be used for parking areas and local roadways and PG 64-34 asphalt cement should be used for roadways with bus traffic. The pavement granular base and subbase should be placed in maximum 300 mm thick lifts and compacted to a minimum of 100% of the material's SPMDD using suitable vibratory equipment.

The proposed pavement structure, where it abuts the existing pavement, should match the existing pavement layers. It is recommended that a 300 mm wide and 50 mm deep stepped joint be provided where the new asphalt layer joins with the existing asphalt layer to provide more resistance to cracking at the joint.

## **6.0 Design and Construction Precautions**

### **6.1 Foundation Drainage and Backfill**

#### **Foundation Drainage and Waterproofing**

It is expected that the building foundation walls will be placed in close proximity to all the boundaries. It is expected that the foundation wall will be blind poured against a drainage system and waterproofing system fastened against the shoring system.

A waterproofing membrane will be required to lessen the effect of water infiltration for the lower P-2 basement level. The waterproofing membrane can be placed and fastened to the shoring system (soldier pile and timber lagging) and should extend to the bottom of the excavation at the founding level of the raft foundation.

It is recommended that the composite drainage system, such as Delta Drain 6000 or equivalent, extend from the exterior finished grade to the founding elevation (underside of raft slab). The purpose of the composite drainage system is to direct any water infiltration resulting from a breach of the waterproofing membrane to the building sump pit. It is recommended that 150 mm diameter sleeves at 3 m centres be cast in the foundation wall at the raft slab interface to allow the infiltration of water to flow to an interior perimeter underfloor drainage pipe. The perimeter drainage pipe should direct water to sump pit(s) within the lower basement area.

#### **Foundation Raft Slab Construction Joints**

If applicable, it is expected that the raft slab will be poured in sections. For the construction joint at each pour should incorporate a rubber water stop along with a chemical grout (Xypex or equivalent) applied to the entire vertical joint of the raft slab. Furthermore, a rubber water stop should be incorporated in the horizontal interface between the foundation wall and the raft slab.

#### **Underfloor Drainage**

Underfloor drainage will be required to control water infiltration due to groundwater infiltration at the proposed founding elevation. For design purposes, we recommend that 150 mm in diameter perforated pipes be placed along the interior perimeter of the foundation wall and one drainage line within each bay. The spacing of the underfloor drainage system should be confirmed at the time of backfilling the floor completing the excavation when water infiltration can be better assessed.

## **Adverse Effects of Dewatering on Adjacent Properties**

It is understood that up to 2 underground parking levels are planned for the proposed development, with the lower portion of the foundation having a groundwater infiltration control system in place. The existing buildings along the west portion are expected to be founded over bedrock or within the glacial till above the bedrock surface.

Based on field observations and assessment, the groundwater level is anticipated at a 5 to 6 m depth below existing grade. A local groundwater lowering is expected under short-term conditions due to construction of the proposed building. It should be noted that the extent of any significant groundwater lowering will take place within a limited range of the subject site due to the minimal groundwater lowering. It should also be noted that the lower portion of the foundation walls will be waterproofed which will limit groundwater lowering within the subject site and surroundings.

Since the neighbouring structures are founded within native glacial till or directly over a bedrock bearing surface based on available soils information. No issues are expected with respect to groundwater lowering that would cause long term damage to adjacent structures surrounding the proposed building.

## **Foundation Backfill**

Above the bedrock surface, backfill against the exterior sides of the foundation walls should consist of free-draining non frost susceptible granular materials. The greater part of the site excavated materials will be frost susceptible and, as such, are not recommended for re-use as backfill against the foundation walls, unless used in conjunction with a drainage geocomposite, such as Miradrain G100N or Delta Drain 6000, connected to the perimeter foundation drainage system. Imported granular materials, such as clean sand or OPSS Granular B Type I granular material, should otherwise be used for this purpose.

## **6.2 Protection of Footings Against Frost Action**

The parking garage may require protection against frost action depending on the founding depth. Unheated structures, such as the access ramp wall footings, may be required to be insulated against the deleterious effect of frost action. A minimum of 2.1 m of soil cover alone, or a minimum of 0.6 m of soil cover, in conjunction with foundation insulation, should be provided.

Perimeter footings of heated structures are required to be insulated against the deleterious effects of frost action. A minimum of 1.5 m of soil cover alone, or a minimum of 0.6 m of soil cover, in conjunction with adequate foundation insulation, should be provided. More details regarding foundation insulation can be provided, if requested.

The effectiveness of this operation will depend on the ability of maintaining vertical trenches until the lean concrete can be poured. It is suggested that once the bottom of the excavation is exposed, an assessment should be completed to determine the water infiltration and stability of the excavation sidewalls extending to the bedrock surface.

Exterior unheated footings, such as those for isolated exterior piers, are more prone to deleterious movement associated with frost action than the exterior walls of the heated structure and require additional protection, such as soil cover of 2.1 m or an equivalent combination of soil cover and foundation insulation.

## **6.3 Excavation Side Slopes**

### **Unsupported Side Slopes**

The side slopes of excavations in the soil and fill overburden materials should either be excavated at acceptable slopes or should be retained by shoring systems from the beginning of the excavation until the structure is backfilled. Insufficient room is expected for majority of the excavation to be constructed by open-cut methods (i.e. unsupported excavations).

The excavation side slopes above the groundwater level extending to a maximum depth of 3 m should be excavated at 1H:1V or shallower. The shallower slope is required for excavation below groundwater level. The subsurface soils are considered to be a Type 2 and 3 soil according to the Occupational Health and Safety Act and Regulations for Construction Projects.

Excavated soil should not be stockpiled directly at the top of excavations and heavy equipment should be kept away from the excavation sides.

Slopes in excess of 3 m in height should be periodically inspected by the geotechnical consultant in order to detect if the slopes are exhibiting signs of distress. A trench box is recommended to protect personnel working in trenches with steep or vertical sides. Services are expected to be installed by "cut and cover" methods and excavations should not remain open for extended periods of time.



## Temporary Shoring

Temporary shoring will be required to support the overburden soils. The design and implementation of these temporary systems will be the responsibility of the excavation contractor or the shoring contractor and their design team. Inspections and approval of the temporary system will also be the responsibility of the designer. Geotechnical information provided below is to assist the designer in completing a suitable and safe shoring system. The designer should take into account the impact of a significant precipitation event and designate design measures to ensure that a precipitation will not negatively impact the shoring system or soils supported by the system. Any changes to the approved shoring design system should be reported immediately to the owner’s representative prior to implementation.

Temporary shoring may be required to complete the required excavations where insufficient room is available for open cut methods. The shoring requirements will depend on the depth of the excavation, the proximity of the adjacent buildings and underground structures and the elevation of the adjacent building foundations and underground services. Additional information can be provided when the above details are known.

For design purposes, the temporary system may consist of soldier pile and lagging system or interlocking steel sheet piling. Any additional loading due to street traffic, construction equipment, adjacent structures and facilities, etc., should be added to the earth pressures described below. These systems can be cantilevered, anchored or braced. The earth pressures acting on the shoring system may be calculated using the following parameters.

<b>Parameters</b>	<b>Values</b>
Active Earth Pressure Coefficient ( $K_a$ )	0.33
Passive Earth Pressure Coefficient ( $K_p$ )	3
At-Rest Earth Pressure Coefficient ( $K_o$ )	0.5
Unit Weight ( $\gamma$ ), kN/m <sup>3</sup>	20
Submerged Unit Weight ( $\gamma$ ), kN/m <sup>3</sup>	13

Generally, it is expected that the shoring systems will be provided with tie-back rock anchors to ensure their stability. It is further recommended that the toe of the shoring be adequately supported to resist toe failure.

The geotechnical design of grouted rock anchors in sedimentary bedrock is based upon two possible failure modes. The anchor can fail either by shear failure along the grout/rock interface or by pullout of a 60 to 90 degree cone of rock with the apex of the cone near the middle of the bonded length of the anchor.

The anchor derives its capacity from the bonded portion, or fixed anchor length, at the base of the anchor. An unbonded portion, or free anchor length, is also usually provided between the rock surface and the start of the bonded length. A factored tensile grout to rock bond resistance value at ULS of **1.0 MPa**, incorporating a resistance factor of 0.3, can be used. A minimum grout strength of 40 MPa is recommended.

It is recommended that the anchor drill hole diameter be within 1.5 to 2 times the rock anchor tendon diameter and the anchor drill holes be inspected by geotechnical personnel and should be flushed clean prior to grouting. The use of a grout tube to place grout from the bottom up in the anchor holes is further recommended.

The geotechnical capacity of each rock anchor should be proof tested at the time of construction. More information on testing can be provided upon request. Compressive strength testing is recommended to be completed for the rock anchor grout. A set of grout cubes should be tested for each day grout is prepared.

### **Soldier Pile and Lagging System**

The active earth pressure acting on a soldier pile and lagging shoring system can be calculated using a rectangular earth pressure distribution with a maximum pressure of  $0.65 K \gamma H$  for strutted or anchored shoring or a triangular earth pressure distribution with a maximum value of  $K \gamma H$  for a cantilever shoring system.  $H$  is the height of the excavation.

The active earth pressure should be used where wall movements are permissible while the at-rest pressure should be used if no movement is permissible.

The total unit weight should be used above the groundwater level while the submerged unit weight should be used below the groundwater level.

The hydrostatic groundwater pressure should be added to the earth pressure distribution wherever the submerged unit weights are used for earth pressure calculations should the level on the groundwater not be lowered below the bottom of the excavation. If the groundwater level is lowered, the total unit weight for the soil should be used full weight, with no hydrostatic groundwater pressure component.

## **Concrete Underpinning**

Based on proximity of existing adjacent buildings support in the form of concrete underpinning maybe required during excavation for the proposed building. It is expected that the founding elevations of the existing foundations will be in close proximity to the bedrock surface (less than 1.5 m) and conventional concrete underpinning may be used to support the full width and length of the foundation.

It is expected that the structural engineer along with the geotechnical engineer will review the site conditions at the time of construction and finalize the underpinning program based on their observations at that time.

## **6.4 Pipe Bedding and Backfill**

Bedding and backfill materials should be in accordance with the most recent Material Specifications & Standard Detail Drawings from the Department of Public Works and Services, Infrastructure Services Branch of the City of Ottawa.

A minimum of 150 mm of OPSS Granular A should be placed for bedding for sewer or water pipes when placed on soil subgrade. If the bedding is placed on bedrock, the thickness of the bedding should be increased to 300 mm for sewer pipes. The bedding should extend to the spring line of the pipe. Cover material, from the spring line to a minimum of 300 mm above the obvert of the pipe should consist of OPSS Granular A (concrete or PSM PVC pipes) or sand (concrete pipe). The bedding and cover materials should be placed in maximum 225 mm thick lifts and compacted to 95% of the SPMDD.

Where hard surface areas are considered above the trench backfill, the trench backfill material within the frost zone (about 1.8 m below finished grade) should match the soils exposed at the trench walls to reduce the potential differential frost heaving. The trench backfill should be placed in maximum 300 mm thick loose lifts and compacted to a minimum of 95% of the SPMDD.

## **6.5 Groundwater Control**

It is anticipated that groundwater infiltration into the excavations should be controllable using open sumps. The contractor should be prepared to direct water away from all bearing surfaces and subgrades, regardless of the source, to prevent disturbance to the founding medium.

A temporary Ministry of Environment, Conservation and Parks (MECP) Category 3 Permit to Take Water (PTTW) may be required if more than 400,000 L/day are to be pumped during the construction phase. At least 4 to 5 months should be allowed for completion of the application and issuance of the permit by the MECP.

For typical ground or surface water volumes being pumped during the construction phase, typically between 50,000 to 400,000 L/day, it is required to register on the Environmental Activity and Sector Registry (EASR). A minimum of two to four weeks should be allotted for completion of the EASR registration and the Water Taking and Discharge Plan to be prepared by a Qualified Person as stipulated under O.Reg. 63/16. If a project qualifies for a PTTW based upon anticipated conditions, an EASR will not be allowed as a temporary dewatering measure while awaiting the MECP review of the PTTW application.

## **6.6 Winter Construction**

Precautions must be taken if winter construction is considered for this project. The subsoil conditions at this site mostly consist of frost susceptible materials. In presence of water and freezing conditions ice could form within the soil mass. Heaving and settlement upon thawing could occur.

In the event of construction during below zero temperatures, the founding stratum should be protected from freezing temperatures by the use of straw, propane heaters and tarpaulins or other suitable means. In this regard, the base of the excavations should be insulated from sub-zero temperatures immediately upon exposure and until such time as heat is adequately supplied to the building and the footings are protected with sufficient soil cover to prevent freezing at founding level.

The trench excavations should be carried out in a manner to avoid the introduction of frozen materials, snow or ice into the trenches. Precaution must be taken where excavations are carried in proximity of existing structures which may be adversely affected due to the freezing conditions. In particular, it should be recognized that where a shoring system is used, the soil behind the shoring system will be subjected to freezing conditions and could result in heaving of the structure(s) placed within or above frozen soil. Provisions should be made in the contract document to protect the walls of the excavations from freezing, if applicable.

## **6.7 Corrosion Potential and Sulphate**

The analytical testing results indicate that the sulphate content is less than 0.1%. This result indicates that Type 10 Portland Cement (i.e. normal cement) would be appropriate for this site. The chloride content and pH of the samples indicate that they are not significant factors in creating a corrosive environment, whereas the resistivity is indicative of an aggressive corrosive environment.

## 7.0 Recommendations

A materials testing and observation services program is a requirement for the provided foundation design data to be applicable. The following aspects of the program should be performed by the geotechnical consultant:

- Review of the geotechnical aspects of the excavating contractor's shoring design, prior to construction.
- Review the bedrock stabilization and excavation requirements.
- Review proposed foundation drainage design and requirements.
- Observation of all bearing surfaces prior to the placement of concrete.
- Sampling and testing of the concrete and fill materials used.
- Observation of all subgrades prior to backfilling.
- Field density tests to determine the level of compaction achieved.

A report confirming that these works have been conducted in general accordance with our recommendations could be issued, upon request, following the completion of a satisfactory materials testing and observation program by the geotechnical consultant.

## 8. Conclusions

---

### i. Whether Phase Two Environmental Site Assessment Required Before Record of Site Condition Submitted

The presence of a former retail fuel outlet and automotive service garage on the southeast portion of the Phase One Property are a significant PCAs which represent APECs for the Property. Given that reports were provided which document remnant PHC/BTEXs soil contamination and that groundwater quality was not confirmed following the completion a remediation program, further investigation is warranted. The contaminants of potential concern associated with retail fuelling are generally PHCs and BTEXs and metals as this was an older facility and lead was historically present in gasoline. Based on historical soil analysis in this area of the Property, PAH and VOCs are also considered contaminants of potential concern associated with the former automotive garage operations.

The practice of backfilling following demolition activities at the Phase One Property is a significant PCA which represents an APEC for the Property. Given that no reports were provided with analytical data to support the environmental quality of the backfill used to fill the former inferred residential building footprint on the central-south portion of the Property, this area warrants further investigation. The contaminants of potential concern commonly found in poor environmental quality backfill are PHCs/BTEXs, PAHs and metals.

The presence of an active automotive service garage was observed on the central portion of the Phase One Property at the time of the Site Investigation. Although this garage has only been operating for a short time period (2018 to present), these operations are a PCA which represents an APEC for the Property. Based on the observations at this automotive garage, that contaminants of potential concern are considered to be PHCs and BTEXs.

Based on the identification of APECs at the Phase One Property, it is recommended that a Phase Two Environmental Site Assessment be completed to assess the soil and/or groundwater quality in the vicinity of the APECs.

### ii. Record of Site Condition Based on Phase One Environmental Site Assessment Alone

Given that there were APECs identified at the Phase One Property, a Phase Two Environmental Site Assessment is required before a record of site condition (RSC) may be submitted with respect to all or part of the Phase One Property.

## 7. Conclusions

---

The soil samples BH1-20-SS5 and BH11-20-SS5 (Duplicate of BH1-20-SS5), collected from a depth of approximately 3.1-3.7 m BGS, had reported concentrations of PHC F2 range (909 µg/g and 306 µg/g vs. 98 µg/g), Methylnaphthalene (7.61 µg/g and 2.26 µg/g vs. 0.99 µg/g) and reported concentrations of vanadium (101 µg/g and 104 µg/g vs. 86 µg/g). These samples also had respective cobalt concentrations of 20.1 µg/g and 22.5 µg/g compared to the site condition standard of 22 µg/g; since the average concentration of cobalt in these samples is less than the site condition standard, the marginal exceedance in the duplicate standard is not considered to exceed the site condition standard. It should be noted that based on past investigations, it has been observed that both Cobalt and Vanadium are known to exceed MECP standards in Ottawa region natural soils, particularly clay.

The soil sample BH3-20-SS6, collected from a depth of approximately 3.8-4.4 m BGS, had reported concentrations of PHC F1 range (117 µg/g vs. 55 µg/g), PHC F2 range (110 µg/g vs. 98 µg/g), benzene (3.02 µg/g vs. 0.21 µg/g), ethylbenzene (59 µg/g vs. 2 µg/g), toluene (73.5 µg/g vs. 2.3 µg/g) and xylenes (276 µg/g vs. 3.1 µg/g). Additionally, PAH exceedances from the same soil sample included Methylnaphthalene (1.95 µg/g vs. 0.99 µg/g) and Naphthalene (1.69 µg/g vs. 0.6 µg/g).

The groundwater samples BH3-20 and BH13-20 (Duplicate of BH3-20), collected from a screen depth of approximately 2.5-5.5 m BGS, had reported concentrations of PHC F1 range (3,600 µg/g and 3,790 µg/g vs. 750 µg/g), PHC F2 range (52,400 µg/g and 2,260 µg/g vs. 150 µg/g), PHC F3 range (3,940 µg/g vs. 500 µg/g), benzene (19,300 µg/g and 19,700 µg/g vs. 44 µg/g), ethylbenzene (3,800 µg/g and 3,700 µg/g vs. µg/g), toluene (65,200 µg/g and 60,900 µg/g vs. 18,000 µg/g) and xylenes (27,600 µg/g and 26,600 µg/g vs. 4,200 µg/g). Lead was also reported at concentrations of 51.6 µg/g and 54.6 µg/g vs. 25 µg/g.

All of the other soil and groundwater results for the Phase Two Property are in compliance with the applicable site condition standards. The Phase Two Property is not in compliance with the site condition standards as of the certification date of June 30, 2020.

It is suspected that remnant soil and/or groundwater contamination may be present near the east Property limits of the Phase Two Property based on historical sampling data, however, this could not be confirmed as part of this Phase Two ESA due to physical impediments (fencing) during the drilling program. Additional investigation and confirmation of soil and groundwater quality in this area of the Property is recommended at the time of excavation for site redevelopment. It should be noted that the proposed redevelopment includes excavation for at least two to three levels of underground parking, which is expected to be sufficient for remediation of the aforementioned environmental contamination at the Phase Two Property.



An environmental remediation program, including the bulk removal and off-site disposal of soil and groundwater in excess of the site condition standards is recommended for the Phase Two Property. Given the scope and timeline for the proposed redevelopment and the requirements for specialized construction techniques to complete remediation of the Phase Two Property to meet the site condition standards, it is recommended that remediation be completed in conjunction with redevelopment of the Property.

Further delineation and confirmation of remediation sampling will be required prior to the completion of an environmental remediation and program and confirmation of compliance with the site condition standards; however, these tasks can be completed at the time decommissioning and demolition of existing structures at the Phase Two Property. The submission of a record of site condition would be required in the event of a change of zoning of the Phase Two Property; however, these tasks can be completed at the time decommissioning and demolition of existing structures at the Phase Two Property. The Phase Two ESA could be then updated at that time to show compliance with site condition standards.

Preparation of a soil management plan in accordance with O.Reg. 406/19 will be required as part of management of excess soil generated as part of construction activities. It is recommended that a remedial action plan be prepared to develop a strategy for remediation, including soil and groundwater management, during redevelopment.

**SITE SERVICING AND STORMWATER MANAGEMENT BRIEF – MOONEY’S BAY - 729  
RIDGEWOOD AVENUE, OTTAWA, ON**

Appendix F City of Ottawa Servicing Study Checklist

## **Appendix F CITY OF OTTAWA SERVICING STUDY CHECKLIST**





**APPLICANT'S STUDY AND PLAN IDENTIFICATION LIST - Draft**

Legend: **S** indicates that the study or plan is required with application submission.

**A** indicates that the study or plan may be required to satisfy a condition of approval/draft approval.

For information and guidance on preparing required studies and plans refer to:

<http://ottawa.ca/en/development-application-review-process-0/guide-preparing-studies-and-plans>

S/A	Number of copies	ENGINEERING		S/A	Number of copies
S		1. Site Servicing Plan	2. Assessment of Adequacy of Public Services / Site Servicing Study / Brief	S	
S		3. Grade Control and Drainage Plan	4. Geotechnical Study / Slope Stability Study	S	
		5. Composite Utility Plan	6. Groundwater Impact Study		
		7. Servicing Options Report	8. Wellhead Protection Study		
S		9. Community Transportation Study and / or Transportation Impact Study / Brief	10. Erosion and Sediment Control Plan / Brief	S	
S		11. Storm water Management Report / Brief	12. Hydro geological and Terrain Analysis		
		13. Hydraulic Water main Analysis	14. Noise / Vibration Study	S	
		15. Roadway Modification Design Plan	16. Confederation Line Proximity Study		

S/A	Number of copies	PLANNING / DESIGN / SURVEY		S/A	Number of copies
		17. Draft Plan of Subdivision	18. Plan Showing Layout of Parking Garage	S	
		19. Draft Plan of Condominium	20. Planning Rationale	S	
S		21. Site Plan	22. Minimum Distance Separation (MDS)		
		23. Concept Plan Showing Proposed Land Uses and Landscaping	24. Agrology and Soil Capability Study		
		25. Concept Plan Showing Ultimate Use of Land	26. Cultural Heritage Impact Statement		
S		27. Landscape Plan	28. Archaeological Resource Assessment Requirements: <b>S</b> (site plan) <b>A</b> (subdivision, condo)		
S		29. Survey Plan	30. Shadow Analysis		
S		31. Architectural Building Elevation Drawings (dimensioned)	32. Design Brief (includes the Design Review Panel Submission Requirements)		
		33. Wind Analysis			

S/A	Number of copies	ENVIRONMENTAL		S/A	Number of copies
S		34. Phase 1 Environmental Site Assessment	35. Impact Assessment of Adjacent Waste Disposal/Former Landfill Site		
A		36. Phase 2 Environmental Site Assessment (depends on the outcome of Phase 1)	37. Assessment of Landform Features		
A		38. Record of Site Condition	39. Mineral Resource Impact Assessment		
S		40. Tree Conservation Report	41. Environmental Impact Statement / Impact Assessment of Endangered Species		
		42. Mine Hazard Study / Abandoned Pit or Quarry Study	43. Integrated Environmental Review (Draft, as part of Planning Rationale)		

**Number of copies**

**\*Reports require 3 copies; Plans require 3 copies + Digital versions of all submissions**

Meeting Date: TBD

Application Type: TBD

File Lead (Assigned Planner): Kelby Lodoen Unseth

Infrastructure Approvals Project Manager: Rubina Rasool

Site Address (Municipal Address): 729 Ridgewood Ave.

\*Preliminary Assessment: 1  2  3  4  5

\*One (1) indicates that considerable major revisions are required before a planning application is submitted, while five (5) suggests that proposal appears to meet the City's key land use policies and guidelines. **This assessment is purely advisory and does not consider technical aspects of the proposal or in any way guarantee application approval.**

*It is important to note that the need for additional studies and plans may result during application review. If following the submission of your application, it is determined that material that is not identified in this checklist is required to achieve complete application status, in accordance with the Planning Act and Official Plan requirements, the Planning, Infrastructure and Economic Development Department will notify you of outstanding material required within the required 30 day period. Mandatory pre-application consultation will not shorten the City's standard processing timelines, or guarantee that an application will be approved. It is intended to help educate and inform the applicant about submission requirements as well as municipal processes, policies, and key issues in advance of submitting a formal development application. This list is valid for one year following the meeting date. If the application is not submitted within this timeframe the applicant must again pre-consult with the Planning, Infrastructure and Economic Development Department.*

## **Appendix G BACKGROUND CORRESPONDENCE**



## Site Plan Pre- Application Consultation Notes

**Date:** Wednesday , May 6, 2020.

**Site Location:** 729 Ridgewood Avenue

**Type of Development:**  Residential ( townhomes,  stacked,  singles,  apartments),  Office Space,  Commercial,  Retail,  Institutional,  Industrial, Other: N/A

**Project Manager:** Sharif Golam

**Assigned Planner:** Kelby Lodoen Unseth

## Infrastructure

### Water

Water District Plan No: 368-025

Existing public services:

- Ridgewood Avenue – 305mm CI



Watermain Frontage Fees to be paid (\$190.00 per metre)  Yes  No

- Existing on-site water service must be shown on the plans. The existing on-site water services will be blanked at the watermain if it will not be reused.
- Service areas with a basic demand greater than 50 m<sup>3</sup>/day shall be connected with a minimum of two water services, separated by an isolation valve, to avoid creation of vulnerable service area.
- A water meter sizing questionnaire [water card] will have to be completed prior to receiving a water permit (water card will be provided post approval)

### Boundary conditions:

Civil consultant must request boundary conditions from the City's assigned Project Manager prior to first submission.

- Water boundary condition requests must include the location of the service(s) and the expected loads required by the proposed developments. Please provide all the following information:
  - Location of service(s)
  - Type of development and the amount of fire flow required (as per FUS, 1999).
  - Average daily demand: \_\_\_ l/s.
  - Maximum daily demand: \_\_\_ l/s.
  - Maximum hourly daily demand: \_\_\_ l/s.
- Fire protection (Fire demand, Hydrant Locations)
- A water meter sizing questionnaire [water card] will have to be completed prior to receiving a water permit (water card will be provided post approval)

## Sanitary Sewer

---

Existing public services:

- Ridgewood Avenue – 225mm Conc.



Is a monitoring manhole required on private property?  Yes  No

- The sanitary sewer design has assumed a population density for the area. The sewer design should demonstrate that the proposed development is within that design criteria or that additional demand can be accommodated.

## Storm Sewer

---

Existing public services:

- Ridgewood Avenue – 300mm Conc.



## Stormwater Management

---

Quality Control:

- Rideau Valley Conservation Authority to confirm quality control requirements.

Quantity Control:

- Master Servicing Study:
  - Sawmills Creek Subwatershed Study
- Allowable Run-off Coefficient: to be calculated as per the Sawmills Creek Subwatershed Study
- Time of concentration (Tc): Tc = pre-development; maximum Tc = 10 min

- Allowable flowrate: Control the 100-year storm events to the 2-year storm event

### Ministry of Environment, Conservation and Parks (MECEP)

All development applications should be considered for an Environmental Compliance Approval, under MECP regulations.

- a. Consultant determines if an approval for sewage works under Section 53 of OWRA is required. Consultant determines what type of application is required and the City's project manager confirms. (If the consultant is not clear if an ECA is required, they will work with the City to determine what is required. If unclear or there is a difference of opinion the City Project Manager will coordinate requirements with MECP).
- b. The project will be either transfer of review (standard), transfer of review (additional), direct submission, or exempt as per O. Reg. 525/98.
- c. Pre-consultation is not required if applying for standard or additional works (Schedule A of the Agreement) under Transfer Review.
- d. Pre-consultation with local District office of MECP is recommended for direct submission.
- e. Consultant completes an MECP request form for a pre-consultation. Sends request to [moeccottawasewage@ontario.ca](mailto:moeccottawasewage@ontario.ca)
- f. ECA applications are required to be submitted online through the MECP portal. A business account required to submit ECA application. For more information visit <https://www.ontario.ca/page/environmental-compliance-approval>

**NOTE: Site Plan Approval, or Draft Approval, is required before any Ministry of the Environment and Climate Change (MOECC) application is signed**

### General Service Design Comments

---

- Ensure that the proposed drive lane entrance to the underground parking garage is protected from the major overland flow route within Ridgewood Avenue.
- The City of Ottawa requests that all new services be located within the existing service trench to minimize necessary road cuts.
- Monitoring manholes should be located within the property near the property line in an accessible location to City forces and free from obstruction (i.e. not a parking).
- Where service length is greater than 30 m between the building and the first maintenance hole / connection, a cleanout is required.
- The City of Ottawa Standard Detail Drawings should be referenced where possible for all work within the Public Right-of-Way.
- The upstream and downstream manhole top of grate and invert elevations are required for all new sewer connections.
- Services crossing the existing watermain or sewers need to clearly provide the obvert/invert elevations to demonstrate minimum separation distances. A watermain crossing table may be provided.

### Other

---

Are there are Capital Works Projects scheduled that will impact the application?  Yes  No

### References and Resources

---

- As per section 53 of the Professional Engineers Act, O. Reg 941/40, R.S.O. 1990, all documents prepared by engineers must be signed and dated on the seal.
- All required plans are to be submitted on standard A1 size sheets (594mm x 841mm) sheets, utilizing a reasonable and appropriate metric scale as per City of Ottawa Servicing and Grading Plan Requirements: title blocks are to be placed on the right of the sheets and not along the bottom. Engineering plans may be combined, but the Site Plans must be provided separately. Plans shall include the survey monument used to confirm datum. Information shall be provided to enable a non-surveyor to locate the survey monument presented by the consultant.
- All required plans & reports are to be provided in \*.pdf format (at application submission and for any, and all, re-submissions)
- Please find relevant City of Ottawa Links to Preparing Studies and Plans below:

<https://ottawa.ca/en/city-hall/planning-and-development/information-developers/development-application-review-process/development-application-submission/guide-preparing-studies-and-plans#standards-policies-and-guidelines>

- To request City of Ottawa plan(s) or report information please contact the City of Ottawa Information Centre:  
[InformationCentre@ottawa.ca](mailto:InformationCentre@ottawa.ca)<<mailto:InformationCentre@ottawa.ca>>  
(613) 580-2424 ext. 44455
- geoOttawa  
<http://maps.ottawa.ca/geoOttawa/>



## SITE PLAN APPLICATION – Municipal servicing

For information on preparing required studies and plans refer to:

<http://ottawa.ca/en/development-application-review-process-0/guide-preparing-studies-and-plans>

S/A	Number of copies	ENGINEERING		S/A	Number of copies
S		1. Site Servicing Plan	2. Site Servicing Study	S	
S		3. Grade Control and Drainage Plan	4. Geotechnical Study	S	
		5. Composite Utility Plan	6. Groundwater Impact Study		
		7. Servicing Options Report	8. Wellhead Protection Study		
		9. Community Transportation Study and/or Transportation Impact Study / Brief	10. Erosion and Sediment Control Plan / Brief	S	
S		11. Storm water Management Report	12. Hydro-geological and Terrain Analysis		
		13. Water main Analysis	14. Noise / Vibration Study	S	
		15. Roadway Modification Design Plan	16. Confederation Line Proximity Study		

S/A	Number of copies	ENVIRONMENTAL		S/A	Number of copies
S		17. Phase 1 Environmental Site Assessment	18. Impact Assessment of adjacent Waste Disposal/Former Landfill Site		
		19. Phase 2 Environmental Site Assessment (depends on the outcome of Phase 1)	20. Assessment of Landform Features		
		21. Record of Site Condition	22. Mineral Resource Impact Assessment		
		23. Tree Conservation Report	24. Environmental Impact Statement / Impact Assessment of Endangered Species		
		25. Mine Hazard Study / Abandoned Pit or Quarry Study			

*It is important to note that the need for additional studies and plans may result during application review. If following the submission of your application, it is determined that material that is not identified in this checklist is required to achieve complete application status, in accordance with the Planning Act and Official Plan requirements, City Planning will notify you of outstanding material required within the required 30 day period. Mandatory pre-application consultation will not shorten the City's standard processing timelines, or guarantee that an application will be approved. It is intended to help educate and inform the applicant about submission requirements as well as municipal processes, policies, and key issues in advance of submitting a formal development application. This list is valid for one year following the meeting date. If the application is not submitted within this timeframe the applicant must again pre-consult with the City.*

### Notes:

4. Geotechnical Study / Slope Stability Study – required as per Official Plan section 4.8.3. All site plan applications need to demonstrate the soils are suitable for development. A Slope Stability Study may be required with unique circumstances (Schedule K or topography may define slope stability concerns).

10. Erosion and Sediment Control Plan – required with all site plan applications as per Official Plan section 4.7.3.

11. Stormwater Management Report/Brief - required with all site plan applications as per Official Plan section 4.7.6.

14. Noise and Vibration Study – a Noise Study will be required if the noise sensitive development is proposed within 250 metres of an existing or proposed highway or a railway right-of-way, or 100 metres of an arterial or collector roadway or rapid-transit corridor. A Vibration Study will be required if the proposed development is within 75 metres of either an existing or proposed railway ROW. A Noise Study may also be required if the proposed development is adjacent to an existing or proposed stationary noise source.

**SITE SERVICING AND STORMWATER MANAGEMENT BRIEF – MOONEY’S BAY - 729  
RIDGEWOOD AVENUE, OTTAWA, ON**

Appendix H Drawings

## **Appendix H DRAWINGS**

