

SERVICING & STORMWATER MANAGEMENT REPORT MIXED USE DEVELOPMENT – 265 CENTRUM



Project No.: CCO-23-3408

City File No.: D07-12-23-0033

Prepared for:

Bayview Orleans Inc
108 Chestnut Street, Toronto, ON M5G 1R3

Prepared by:

McIntosh Perry Consulting Engineers Ltd.
115 Walgreen Road
Carp, ON K0A 1L0

March 24, 2023

Rev: March 19, 2024

McINTOSH PERRY

TABLE OF CONTENTS

1.0	PROJECT DESCRIPTION.....	1
1.1	Purpose.....	1
1.2	Site Description	1
1.3	Proposed Development and Statistics	2
1.4	Existing Conditions and Infrastructure.....	2
1.5	Approvals.....	3
2.0	BACKGROUND STUDIES.....	3
2.1	Applicable Guidelines and Standards	3
3.0	PRE-CONSULTATION SUMMARY.....	5
4.0	WATERMAIN.....	6
4.1	Existing Watermain	6
4.2	Proposed Watermain.....	6
5.0	SANITARY DESIGN.....	9
5.1	Existing Sanitary Sewer.....	9
5.2	Proposed Sanitary Sewer	9
5.3	Proposed Sanitary Capacity	10
6.0	STORM SEWER DESIGN.....	11
6.1	Existing Storm Sewers.....	11
6.2	Proposed Storm Sewers.....	11
7.0	PROPOSED STORMWATER MANAGEMENT.....	12
7.1	Design Criteria and Methodology.....	12
7.2	Runoff Calculations.....	12
7.3	Pre-Development Drainage.....	13
7.4	Post-Development Drainage.....	13
7.5	Quality Control	15
8.0	EROSION AND SEDIMENT CONTROL.....	16
8.1	Temporary Measures.....	16
8.2	Permanent Measures	16
9.0	SUMMARY.....	18
10.0	RECOMMENDATION	19
11.0	STATEMENT OF LIMITATIONS.....	20

LIST OF TABLES

Table 1: Water Demands.....	7
Table 2: Fire Protection Confirmation.....	7
Table 3: Boundary Condition Results.....	8
Table 4: Sanitary Design Criteria.....	9
Table 5: Summary of Estimated Sanitary Flow	10
Table 6: Pre-Development Runoff Summary.....	13
Table 7: Post-Development Runoff Summary	14

APPENDICES

Appendix A: Site Location Plan

Appendix B: City of Ottawa Pre-Consultation Notes

Appendix C: Watermain Calculations

Appendix D: Sanitary Calculations

Appendix E: Pre-Development Drainage Plan

Appendix F: Post-Development Drainage Plan

Appendix G: Stormwater Management Calculations

Appendix H: City of Ottawa Design Checklist

1.0 PROJECT DESCRIPTION

1.1 Purpose

McIntosh Perry (MP) has been retained by Bayview Orleans Inc to prepare this Servicing and Stormwater Management Report in support of the Site Plan Control process for the proposed mixed-use development, located at 265 Centrum within the City of Ottawa (City File No. PC2022).

The main purpose of this report is to present a servicing design for the development in accordance with the recommendations and guidelines provided by the City of Ottawa (City), the Rideau Valley Conservation Authority (RVCA), and the Ministry of the Environment, Conservation and Parks (MECP). This report will address the water, sanitary and storm sewer servicing for the development, ensuring that existing and available services will adequately service the proposed development.

This report should be read in conjunction with the following drawings:

- COO-23-3408, C101 – Site Grading and Drainage Plan,
- COO-23-3408, C102 – Site Servicing Plan, and
- COO-23-3408, POST – Post-Development Drainage Area Plan (Appendix F)

1.2 Site Description

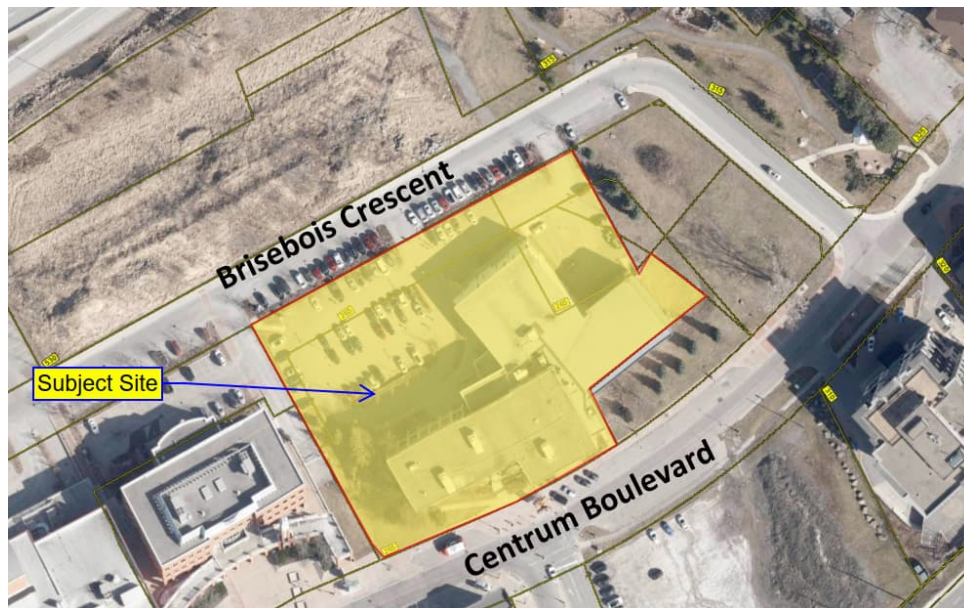

Figure 1: Site Map

The subject property, herein referred to as the site, is located 265 Centrum Boulevard within the Orleans East-Cumberland ward. It is described as Registered Plan 50M-165, City of Ottawa. The land in question covers approximately 0.90 ha and is located between Centrum Boulevard and Brisebois Crescent. See Site Location Plan in Appendix A for more details.

1.3 Proposed Development and Statistics

The proposed development consists of a 35-storey mixed-use residential building, a 30-storey mixed-use residential building, and a 40-storey residential building. Drive aisles will extend through the site from the three proposed accesses from Brisebois Crescent. Underground parking will be provided for residents and visitors. Refer to the Site Plan prepared by B+H Architects included in Appendix B for details.

1.4 Existing Conditions and Infrastructure

The existing site is currently developed as a recreational facility with parking provided to the north of the property.

Sewer and watermain mapping collected from the City of Ottawa indicate that the following services exist across the property frontages within the adjacent municipal rights-of-way(s):

- Centrum Boulevard
 - 305 mm diameter ductile iron watermain,
 - 250 mm PVC and 450 mm diameter concrete sanitary sewer tributary to the Cumberland Collector, and a
 - 600 mm diameter concrete storm sewer tributary to the Ottawa River approximately 1.1 km downstream.
- Brisebois Crescent
 - 203 mm diameter PVC watermain,
 - 250 mm PVC sanitary sewer tributary to the Cumberland Collector, and a
 - 750-900 mm diameter concrete storm sewer tributary to the Ottawa River approximately 1.1 km downstream.

Water servicing for the site is provided via a private 152 mm diameter water service extending from the 305mm ductile iron watermain within Centrum Boulevard.

Sanitary servicing for the site is provided via a 150 mm diameter sanitary service extending from the 450 mm diameter concrete sanitary sewer within Centrum Boulevard. There is also a private 150-200 mm diameter PVC sanitary sewer that services the site extending from the existing 250 mm diameter PVC sanitary sewer within Brisebois Crescent.

Storm servicing for the site is provided via a private storm sewer ranging from 250 mm to 300 mm in diameter extending from the existing 600mm diameter sewer within Centrum Boulevard. There

is also a private storm sewer ranging from 300 mm to 900 mm in diameter and extending from the 750-900mm diameter storm sewer within Brisebois Crescent.

1.5 Approvals

The proposed development is subject to the City of Ottawa site plan control approval process. Site plan control requires the City to review, provided concurrence and approve the engineering design package. Permits to construct can be requested once the City has issued a site plan agreement.

An Environmental Compliance Approval (ECA) through the Ministry of Environment, Conservation and Parks (MECP) is not anticipated to be required for the development since the development is contained within a single parcel of land, is not within a combined sewershed, and does not propose industrial sewage. As a result, the stormwater management system meets the exemption requirements under O.Reg 525/90..

2.0 BACKGROUND STUDIES

Background studies that have been completed for the proposed site include City of Ottawa as-built drawings, a topographical survey, and a geotechnical report.

As-built drawings of existing services within the vicinity of the proposed site were reviewed in order to determine accurate servicing and stormwater management schemes for the site.

A topographic survey of the site was completed by Annis, O'Sullivan, Vollebakk Ltd and dated November 29, 2021.

The following reports have previously been completed and are available under separate cover:

- Orleans Town Centre (West) Serviceability and Stormwater Management Report completed by Novatech Engineering Consultants.
- NCR YMCA/YWCA Orleans Facility 265 Centrum Serviceability and Stormwater Management Report completed by Novatech Engineering Consultants, dated June 9, 2009, Revised July 26, 2010.
- Municipal Servicing Report Orleans Town Centre Lands completed by J.L. Richards & Associated Ltd., dated November 2005.

2.1 Applicable Guidelines and Standards

City of Ottawa:

- ◆ Ottawa Sewer Design Guidelines, City of Ottawa, SDG002, October 2012. (Ottawa Sewer Guidelines)
 - Technical Bulletin ISTB-2014-01 City of Ottawa, February 2014. (ISTB-2014-01)
 - Technical Bulletin PIEDTB-2016-01 City of Ottawa, September 2016. (PIEDTB-2016-01)
 - Technical Bulletin ISTB-2018-01 City of Ottawa, January 2018. (ISTB-2018-01)
 - Technical Bulletin ISTB-2018-03 City of Ottawa, March 2018. (ISTB-2018-03)

- Technical Bulletin ISTB-2019-01 City of Ottawa, January 2019. (ISTB-2019-01)
- Technical Bulletin ISTB-2019-02 City of Ottawa, February 2019. (ISTB-2019-02)
- ◆ Ottawa Design Guidelines – Water Distribution City of Ottawa, July 2010. (Ottawa Water Guidelines)
 - Technical Bulletin ISD-2010-2 City of Ottawa, December 15, 2010. (ISD-2010-2)
 - Technical Bulletin ISDTB-2014-02 City of Ottawa, May 2014. (ISDTB-2014-02)
 - Technical Bulletin ISTB-2018-02 City of Ottawa, March 2018. (ISTB-2018-02)

Ministry of Environment, Conservation and Parks:

- ◆ Stormwater Planning and Design Manual, Ministry of the Environment, March 2003. (MECP Stormwater Design Manual)
- ◆ Design Guidelines for Sewage Works, Ministry of the Environment, 2008. (MECP Sewer Design Guidelines)

Other:

- ◆ Water Supply for Public Fire Protection, Fire Underwriters Survey, 2020. (FUS Guidelines)

3.0 PRE-CONSULTATION SUMMARY

A pre-consultation meeting was conducted on March 22, 2022 regarding the proposed site. Specific design parameters to be incorporated within this design include the following:

- The servicing report is required to refer to existing studies for this area to demonstrate the maximum allowable release rate.
- The City is to be consulted for site specific quality control measures.

The notes from the City of Ottawa can be found in Appendix B.

4.0 WATERMAIN

4.1 Existing Watermain

The site is located within the 1E pressure zone, as per the Water Distribution System Mapping included in Appendix C. There is an existing 203 mm diameter PVC watermain within Brisebois and a 305mm diameter ductile iron watermain within Centrum Boulevard. The site is currently serviced for water via a 150 mm diameter service extending from the 305mm ductile iron watermain within Centrum Boulevard. There are four public hydrants located on Brisebois Crescent and three public hydrants located on Centrum Boulevard available to provide fire flow to the development.

4.2 Proposed Watermain

Two new 150mm diameter PVC water services are proposed to service the development complete with water valves located at the property line. The water services are proposed to be serviced by the existing 203 mm diameter watermain within Brisebois Crescent. The services are designed to have a minimum of 2.4m cover. A private hydrant, to be designed by the Mechanical Engineer, will be installed on site. Refer to drawing C102 for a detailed servicing layout.

The Fire Underwriters Survey 2020 (FUS) method was utilized to determine the required fire flow for the site. The 'C' factor (type of construction) for the FUS calculation was determined to be 0.8 (non-combustible construction). The total effective floor area ('A' value) for the FUS calculation was determined to be 7,292 m², 5,481 m² and 5,230 m² for Building A, Building B and Building C, respectively. The results of the calculations yielded a required fire flow of 11,000 L/min for Building A, 8,000 L/min for Building B and 9,000 L/min for Building C, respectively. The detailed calculations for the FUS can be found in Appendix C.

The water demands for the proposed building have been calculated to adhere to the Ottawa Design Guidelines – Water Distribution manual and can be found in Appendix C. The results have been summarized below. In accordance with Section 4.3.1 of the guidelines, service areas with a basic day demand greater than 50 m³/day require a dual connection to the municipal system. The basic day demand for the development is estimated to be 550.6 m³/day, therefore a dual connection is required.

Table 1: Water Demands

Site Area	0.90ha
Residential	280 L/c/day
Commercial	28,000 L/ha/day
Average Day Demand (L/s)	6.37
Maximum Daily Demand (L/s)	15.89
Peak Hourly Demand (L/s)	34.95
FUS Fire Flow Requirement (L/s)	183.33

To confirm the adequacy of fire flow to protect the proposed development, public fire hydrants within 150 m of the proposed building were reviewed per City of Ottawa ISTB 2018-02 Appendix I Table 1. Based on City guidelines (ISTB-2018-02), the existing hydrants can provide adequate fire coverage to the proposed development. The results are summarized below.

Table 2: Fire Protection Confirmation

Building	Fire Flow Demand (L/min.)	Fire Hydrant(s) within 75m*	Fire Hydrant(s) within 150m*	Combined Fire Flow (L/min.)
Building A	11,000 (FUS)	3	4	32,300
Building B	8,000 (FUS)	3	4	32,300
Building C	8,000 (FUS)	3	4	32,300

* Fire hydrants within 75 metres contribute 5,700 L/min to fire flow and fire hydrants within 150 meters contribute 3,800 L/min to fire flow, respectively, per ISTB-2018-02.

The City provided the estimated water pressures at both for the average day scenario, peak hour scenario and the max day plus fire flow scenario for the demands indicated by the correspondence in Appendix B. The resulting pressures for the boundary conditions results are shown in Table 3, below.

Table 3: Boundary Condition Results

Scenario	Proposed Demands (L/s)	Connection 1 (West) HGL (m H ₂ O)* / kPa	Connection 2 (East) HGL (m H ₂ O)* / kPa
Average Day Demand	6.37	46.4 / 455.2	46.1 / 452.2
Maximum Daily + Fire Flow Demand	199.22	24.8 / 243.3	25.2 / 247.2
Peak Hourly Demand	34.95	39.4 / 386.5	39.1 / 383.6
* Adjusted for an estimated ground elevation of 67.6 m above the west connection point and 67.9m above the east connection point.			

The normal operating pressure range is anticipated to be 384 kPa to 455 kPa and will not be less than 275 kPa (40 psi) or exceed 689 kPa (100 psi). The proposed watermains will meet the minimum required 20 psi (140 kPa) from the Ottawa Water Guidelines at the ground level under maximum day demand and fire flow conditions. A pressure reducing valve is not anticipated to be required since the pressures do not exceed 552 kPa (80 psi) in the average day scenario.

5.0 SANITARY DESIGN

5.1 Existing Sanitary Sewer

There is an existing 250 mm diameter PVC and 450 mm diameter Concrete sanitary sewer within Centrum Boulevard, tributary to the Cumberland Collector. There is also an existing 250 mm diameter PVC sanitary sewer within Brisebois Crescent, tributary to the Cumberland Collector. Refer to the City of Ottawa Trunk Sewer Map figure available in Appendix D.

Sanitary servicing for the site is provided via a 150 mm diameter sanitary service extending from the 450 mm diameter concrete sanitary sewer within Centrum Boulevard and a private 150-200 mm diameter sewer extending from the 250 mm sewer within Brisebois Crescent.

5.2 Proposed Sanitary Sewer

A new 200 mm diameter gravity sanitary service is proposed to be connected to the existing 250 mm diameter sanitary sewer within Brisebois Crescent. The sanitary service will be complete with a maintenance hole (MH1A) which will be installed at the property line as per the City of Ottawa – Sewer Design Guidelines.

The proposed development consists of three mixed-use residential buildings. The peak design flows for the proposed buildings were calculated using criteria from the Ottawa Sewer Guidelines and are summarized in Table 4, below.

Table 4: Sanitary Design Criteria

Design Parameter	Value
Ste Area	0.90 ha
Residential Demand	280 L/c/d
Residential Peaking Factor	3.07
Commercial/ Amenity	2,800 L/(1000m ² /d)
Institutional Peaking Factor	1.0
Office Demand	75 L/7.0m ² /d
Extraneous Flow Allowance	0.33 L/s/ha

Based on the unit occupancy statistics provided by the architect, the proposed site development will generate a flow of 20.3 L/s. Table 5 below, summarizes the estimated wastewater flow from the proposed development. Refer to Appendix D for detailed calculations.

Table 5: Summary of Estimated Sanitary Flow

Design Parameter	Total Flow (L/s)
Total Estimated Average Dry Weather Flow	6.85
Total Estimated Peak Dry Weather Flow	20.00
Total Estimated Peak Wet Weather Flow	20.25

5.3 Proposed Sanitary Capacity

The proposed sanitary network has been designed to attain a minimum full flow target velocity (cleansing velocity) of 0.6 m/s and a full flow velocity of not more than 3.0 m/s. The capacity of the proposed 200 mm diameter sanitary service with a slope of 1.00% is 34.22 L/s based on sanitary sewer design calculations available in Appendix D.

Based on the Orleans Town Centre (West) Serviceability and Stormwater Management Report, the existing 250 mm diameter sewer within Brisebois Crescent has a design flow 6.46 L/s and a capacity of 30.2 L/s. The existing sewer will have capacity to convey existing sanitary design flow and the additional 20.3 L/s peak flow from the proposed development at 89% of the pipe capacity. Refer to Appendix D.

The City Asset Management Branch has identified that there is sufficient capacity for the existing sanitary mains to accept the proposed sanitary flow.

6.0 STORM SEWER DESIGN

6.1 Existing Storm Sewers

Storm servicing for the site is provided via a private storm sewer ranging from 250 mm to 300 mm in diameter and extending from the existing 600 mm diameter sewer within Centrum Boulevard. Drainage from the sewer within Centrum Boulevard is tributary to the Ottawa River approximately 1.1 Km downstream.

There is also a private storm sewer ranging from 300mm to 900mm in diameter and extending from the 750-900mm diameter storm sewer within Brisebois Crescent. Per the Orleans Town Centre West Stormwater Management Report, drainage from the storm sewer within Brisebois is conveyed to a stormwater management pond northeast of the site and ultimately the Ottawa River.

6.2 Proposed Storm Sewers

A new 375mm diameter storm service is proposed to be extended from the existing 750mm diameter storm sewer within Brisebois Crescent and a new 250mm diameter storm service is proposed to be extended from the existing 600mm diameter storm sewer within Centrum Boulevard.

Runoff from at-grade areas will be collected by proposed drain structures. Surface runoff will be conveyed to an internal cistern that will attenuate drainage using an ICD before discharging via the proposed 375mm diameter storm service.

Runoff collected from the roof of Building A will be collected and attenuated by roof drains. Roof drainage will then discharge via the 250mm diameter storm service.

Runoff collected from the roofs of Building B and Building C will be collected and attenuated by roof drains. Roof drainage will then discharge via the 375mm diameter storm service.

Foundation drainage will be conveyed to the existing 600mm diameter storm sewer within Brisebois via the proposed 375mm diameter storm service downstream of roof and cistern controls.

See drawing C102 for a detailed servicing layout and OOO-23-1150 - POST included in Appendix 'F' of this report for more details. The Stormwater Management design for the subject property will be outlined in Section 7.0 of this report.

7.0 PROPOSED STORMWATER MANAGEMENT

7.1 Design Criteria and Methodology

Stormwater management for the proposed site will be maintained through two methods. The first will store and control runoff collected on the roof of the proposed buildings. Building A, Building B, Building C will use twenty, nine and thirteen-Watts Accutrol Weirs (fully closed), respectively, to control the release rate of the roof drainage. The second will control stormwater via an internal cistern and will collect runoff from the at-grade areas within the site. Runoff from Building B, Building C, and the cistern will be directed to the 750mm diameter storm sewer within Brisebois Crescent. Runoff from Building A will be directed to the 600mm storm sewer within Centrum Boulevard. In summary, the following design criteria have been employed in developing the stormwater management design for the site as directed by the RVCA and City:

Quality Control

- The site has been designed to achieve an 80% total suspended solids removal (enhanced level).

Quantity Control

- Post-development peak flows conveyed to the Brisebois storm sewer to be restricted to the existing peak flows per the Serviceability and Stormwater Management Report.
- Post-development peak flows conveyed to the Centrum storm sewer to be restricted to the peak attenuated roof flow from Proposed Building A.

7.2 Runoff Calculations

Runoff calculations presented in this report are derived using the Rational Method, given as:

$$Q = 2.78CIA \text{ (L/s)}$$

Where	C	= Runoff coefficient
	I	= Rainfall intensity in mm/hr (City of Ottawa IDF curves)
	A	= Drainage area in hectares

It is recognized that the Rational Method tends to overestimate runoff rates. As a result, the conservative calculation of runoff ensures that any SWM facility sized using this method is expected to function as intended.

The following coefficients were used to develop an average C for each area:

Roofs/ Concrete/ Asphalt	0.90
Gravel	0.60
Undeveloped and Grass	0.20

As per the City of Ottawa - Sewer Design Guidelines, the 5-year balanced 'C' value must be increased by 25% for a 100-year storm event to a maximum of 1.0.

7.3 Pre-Development Drainage

The existing drainage limits for the north part of the site are demonstrated on the YMCA Expansion Revised Drainage Area Plan available in Appendix E. Existing site drainage limits for the south part of the site were requested from the City in order to determine pre-development runoff conditions. Per communications with the City attached in Appendix B, a pre-development conditions plan for the southern part of the site was unavailable.

Table 6: Pre-Development Runoff Summary

Drainage Area	Area (ha)	Q (L/s)
		100-Year
YMCA-Expansion	0.11	4.50
YMCA-Grass	0.02	3.00
YMCA-Parking	0.47	27.40
Total	0.60	34.90

See Appendix E for an existing conditions drainage plan and Appendix G for calculations.

7.4 Post-Development Drainage

The proposed site drainage limits are demonstrated on the Post-Development Drainage Area Plan. See COO-23-3408 - POST in Appendix 'F' of this report for more details. A summary of the Post-Development Runoff Calculations can be found below.

Table 7: Post-Development Runoff Summary

Drainage Area	Area (ha)	5-Year Peak Flow (L/s)	100-Year Peak Flow (L/s)	100-Year Storage Requirement (m ³)	100-Year Storage Available (m ³)
B1	0.14	7.50	7.89	35.9	37.6
B2	0.16	5.40	5.68	52.7	58.8
B3	0.37	7.93	15.22	119.3	119.3
B4	0.02	3.06	6.02	-	-
Brisebois Total	0.69	23.89	34.80	207.9	215.7
B5	0.21	8.52	8.52	56.5	65.9
Centrum Total	0.21	8.52	8.52	56.5	65.9

After discussing the stormwater management criteria for the site with City Staff, the total post-development drainage conveyed to the Brisebois storm sewer is not to exceed the existing release rate of 34.90 L/s per the Serviceability and Stormwater Management Report. Post-development drainage conveyed to the Centrum storm sewer is to be limited to the attenuated roof flow rate of Building A.

Post-development drainage conveyed to the Brisebois storm sewer will be restricted to a maximum release rate of 34.90 L/s based on a maximum release rate requirement of 34.90 L/s. Based on City requirements attached in Appendix B, the post-development drainage conveyed to the Centrum storm sewer is to be the restricted runoff from Building A (B5), or 8.52 L/s.

To meet the stormwater objectives the development will contain a combination of flow attenuation with rooftop controls and cistern storage.

Runoff for area B1 will be stored on the roof of the proposed Building C and restricted using twenty-five (25) fully closed Watts Accutrol roof drains (or approved equivalent) to a maximum release rate of 7.89 L/s and will provide up to 37.6 m³ of surface storage.

Runoff for area B2 will be stored on the roof of the proposed Building B and restricted using eighteen (18) fully closed Watts Accutrol roof drains (or approved equivalent) to a maximum release rate of 5.68 L/s and will provide up to 58.8 m³ of surface storage.

Runoff for area B3 will be collected by surface drains and conveyed to the Internal cistern. The internal cistern will attenuate flows to a maximum release rate of 15.22 L/s with 119.3 m³ of storage. Flows in excess of the 100-year storm event will need to be directed towards Brisebois Crescent via a cistern overflow. Cistern details are to be confirmed by the Mechanical Engineer.

Runoff for area B4 will be directed to the Brisebois Crescent right of way without attenuation and will be compensated for in areas with attenuation.

Runoff for area B5 will be stored on the roof of the proposed Building A and restricted using twenty-seven (27) fully closed Watts Accutrol roof drains (or approved equivalent) to a maximum release rate of 8.52 L/s and will provide up to 65.9 m³ of surface storage.

7.5 Quality Control

As Per the Orleans Town Centre (West) Serviceability and Stormwater Management Report, drainage from the Brisebois storm service is tributary to a SWM Pond northeast of the site. The SWM Pond has been designed to provide 70% TSS removal for runoff collected by the sewer. Treated runoff from the SWM pond enters a storm sewer where it is discharged to the Ottawa River, approximately 1.0 Km downstream. Runoff from the Centrum storm service is tributary to the Ottawa River approximately 1.5 Km downstream. Based on the distance from the site runoff to the outlet, City Staff has advised that on site quality controls are not required.

8.0 EROSION AND SEDIMENT CONTROL

8.1 Temporary Measures

Before construction begins, temporary silt fence, straw bale or rock flow check dams will be installed at all natural runoff outlets from the property. It is crucial that these controls be maintained throughout construction and inspection of sediment and erosion control will be facilitated by the Contractor or Contract Administration staff throughout the construction period.

Silt fences will be installed where shown on the final engineering plans, specifically along the downstream property limits. The Contractor, at their discretion or at the instruction of the City, Conservation Authority or the Contract Administrator shall increase the quantity of sediment and erosion controls on-site to ensure that the site is operating as intended and no additional sediment finds its way off site. The rock flow, straw bale & silt fence check dams and barriers shall be inspected weekly and after rainfall events. Care shall be taken to properly remove sediment from the fences and check dams as required. Fibre roll barriers are to be installed at all existing curb inlet catchbasins and filter fabric is to be placed under the grates of all existing catchbasins and manholes along the frontage of the site and any new structures immediately upon installation. The measures for the existing/proposed structures is to be removed only after all areas have been paved. Care shall be taken at the removal stage to ensure that any silt that has accumulated is properly handled and disposed of. Removal of silt fences without prior removal of the sediments shall not be permitted.

Although not anticipated, work through winter months shall be closely monitored for erosion along sloped areas. Should erosion be noted, the Contractor shall be alerted and shall take all necessary steps to rectify the situation. Should the Contractor's efforts fail at remediating the eroded areas, the Contractor shall contact the City and/or Conservation Authority to review the site conditions and determine the appropriate course of action. As the ground begins to thaw, the Contractor shall place silt fencing at all required locations as soon as ground conditions warrant. Please see the Site Grading, Drainage and Sediment & Erosion Control Plan for additional details regarding the temporary measures to be installed and their appropriate OPSD references.

8.2 Permanent Measures

Rip-rap will be placed at all locations that have the potential for concentrated flow. It is crucial that the Contractor ensure that the geotextile is keyed in properly to ensure runoff does not undermine the rip rapped area. Additional rip rap is to be placed at erosion prone locations as identified by the Contractor / Contract Administrator / City or Conservation Authority.

It is expected that the Contractor will promptly ensure that all disturbed areas receive topsoil and seed/sod and that grass be established as soon as possible. Any areas of excess fill shall be removed or levelled as soon as possible and must be located a sufficient distance from any watercourse to ensure that no sediment is washed out into the watercourse. As the vegetation growth within the

site provides a key component to the control of sediment for the site, it must be properly maintained once established. Once the construction is complete, it will be up to the landowner to maintain the vegetation and ensure that the vegetation is not overgrown or impeded by foreign objects.

9.0 SUMMARY

- Three new mixed-use residential buildings are proposed to be constructed at 265 Centrum Boulevard.
- Dual 150 mm diameter water services are proposed to be connected to the existing 203 mm diameter watermain within Brisebois Crescent.
- A private hydrant, to be designed by the Mechanical Engineer, will be installed on site.
- A new 200 mm diameter sanitary service complete with a maintenance hole at the property line is proposed to service the development, extending from the existing 250 mm diameter sanitary service within Brisebois Crescent.
- A new 375 mm storm service for rooftop, surface, and foundation drainage is proposed to service the development. The storm service will connect to the 750 mm diameter storm sewer within Brisebois Crescent.
- A new 250 mm storm service is proposed to service rooftop drainage for Building A, extending from the 600 mm diameter storm sewer within Centrum Boulevard.
- Storage for the 5- through 100-year storm events will be provided through roof attenuation and internal cistern attenuation.
- On site quality controls are not required for the development.

10.0 RECOMMENDATION

Based on the information presented in this report, we recommend that City of Ottawa approve this Servicing and Stormwater Management Report in support of the proposed mixed-use residential development at 265 Centrum Boulevard.

This report is respectfully being submitted for approval.

Regards,

McIntosh Perry Consulting Engineers Ltd.



Andrew MacLeod, P.Eng.
Senior Engineer
T: 365.527.2696
E: a.macleod@mcintoshperry.com

A handwritten signature in black ink that reads "Ryan Robineau".

Ryan Robineau, B.Eng.
Project Coordinator
T: 613.714.6611
E: r.robineau@mcintoshperry.com

11.0 STATEMENT OF LIMITATIONS

This report was produced for the exclusive use of Bayview Orleans Inc. The purpose of the report is to assess the existing stormwater management system and provide recommendations and designs for the post-construction scenario that are in compliance with the guidelines and standards from the Ministry of the Environment, Conservation and Parks, City of Ottawa and local approval agencies. McIntosh Perry reviewed the site information and background documents listed in Section 2.0 of this report. While the previous data was reviewed by McIntosh Perry and site visits were performed, no field verification/measures of any information were conducted.

Any use of this review by a third party, or any reliance on decisions made based on it, without a reliance report is the responsibility of such third parties. McIntosh Perry accepts no responsibility for damages, if any, suffered by any third party as a result of decisions or actions made based on this review.

The findings, conclusions and/or recommendations of this report are only valid as of the date of this report. No assurance is made regarding any changes in conditions subsequent to this date. If additional information is discovered or becomes available at a future date, McIntosh Perry should be requested to re-evaluate the conclusions presented in this report, and provide amendments, if required.

APPENDIX A
KEY PLAN

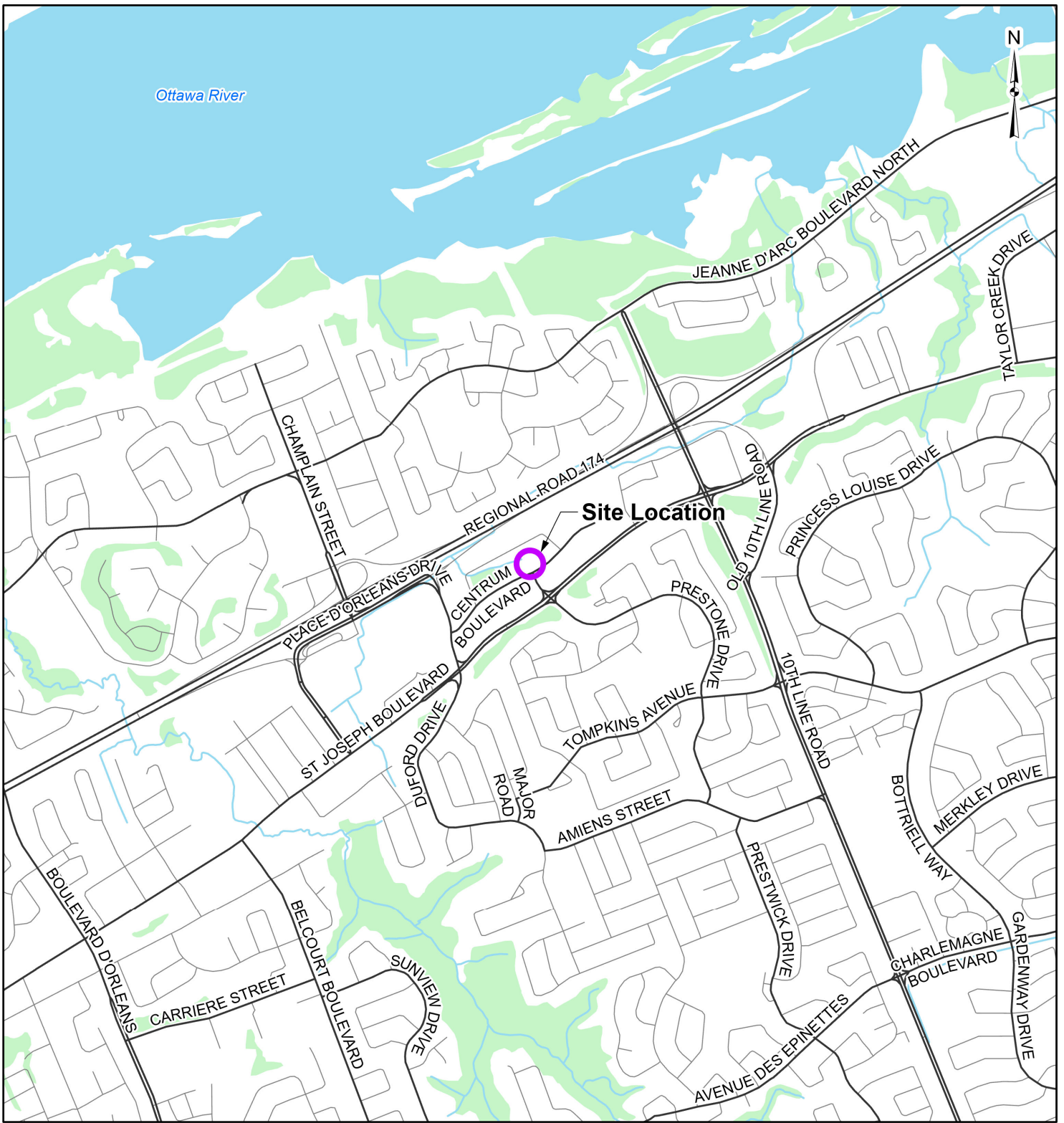

LEGEND

- Site Location
- Local Road
- Major Road
- Watercourse
- Waterbody
- Wooded Area



REFERENCE

GIS data provided by the Ontario Ministry of Natural Resources and Forestry, 2023.

CLIENT:		DEMARCO CONSTRUCTION LTD.	
PROJECT:		265 CENTRUM BOULEVARD	
TITLE:		SITE LOCATION	
McINTOSH PERRY <small>115 Walgreen Road, RR3, Carp, ON K0A1L0 Tel: 613-836-2184 Fax: 613-836-3742 www.mcintoshperry.com</small>	PROJECT NO: CCO-23-3408	FIGURE:	1
	Date	Feb., 07, 2023	
	GIS	AH	
Checked By	RR		

C:\Users\hamed\McIntosh Perry\GIS - Documents\Projects\2023\CCO-23-3408 Demarco Apartment 265 Centrum Boulevard\appx\LandDevelopment\CCO-23-3408_SiteLocation.aprx

APPENDIX B
BACKGROUND DOCUMENTS

Zoning Pre-Application Consultation Notes

Date: Tuesday, March 22, 2022.

Site Location: 265 Centrum Blvd

Type of Development: Residential (townhomes, stacked, singles, apartments), Office Space, Commercial, Retail, Institutional, Industrial, Other: N/A

Infrastructure

Water

Existing public services:

- Centrum Blvd – 200mm PVC
- Brisebois Cres – 305mm DI

Watermain Frontage Fees to be paid (\$190.00 per metre) Yes No

Boundary conditions:

Civil consultant must request boundary conditions from the City's assigned Project Manager prior to first submission.

- Water boundary condition requests must include the location of the service(s) and the expected loads required by the proposed developments. Please provide all the following information:
 - Location of service(s)
 - Type of development and the amount of fire flow required (as per FUS, 1999)
 - Average daily demand: ___ L/s
 - Maximum daily demand: ___ L/s
 - Maximum hourly daily demand: ___ L/s
- Fire protection (Fire demand, Hydrant Locations)
- Please submit sanitary demands with the water boundary conditions.

General comments

- Service areas with a basic demand greater than 50 m³/day shall be connected with a minimum of two water services, separated by an isolation valve, to avoid creation of vulnerable service area.
- A District Metering Area Chamber (DMA) is required for services 150mm or greater in diameter.

Sanitary Sewer

Existing public services:

- Centrum Blvd – 450mm Conc
- Brisebois Cres – 250mm PVC

Is a monitoring manhole required on private property? Yes No

General comments

- The servicing report is required to refer to existing studies for this area to demonstrate there is sufficient capacity for the proposed rezoning. The servicing report should focus on the maximum sanitary demands that can be anticipated based on zone and not a specific proposal. Note that the parcels may have changed since the time of the original report and this should be taken into consideration when allocating demands for the area.
 - Municipal Servicing Report Orleans Town Centre Lands, Report JLR 20724, prepared by J.L. Richards & Associates Ltd, dated Nov 2005.
 - Orleans Town Centre Lands (West) Serviceability Stormwater Management Report, Report No. R-2007-103, prepared by Novatech Engineering Consultants Ltd., dated 27 July 2007, revised 15 January 2008.
- The servicing report is required to demonstrate that the city mains are sized adequately to support the additional sanitary demands.
- Please submit sanitary demands with the water boundary conditions.

Storm Sewer

Existing public services:

- Centrum Blvd – 600mm Conc
- Brisebois Cres – 750mm PVC

General comments

- The servicing report is required to refer to existing studies for this area to demonstrate the maximum allowable release rate. Note that the parcels may have changed since the time of the original report and this should be taken into consideration when allocating demands for the area.
 - Municipal Servicing Report Orleans Town Centre Lands, Report JLR 20724, prepared by J.L. Richards & Associates Ltd, dated Nov 2005.
 - Orleans Town Centre Lands (West) Serviceability Stormwater Management Report, Report No. R-2007-103, prepared by Novatech Engineering Consultants Ltd., dated 27 July 2007, revised 15 January 2008.
- Prior to rezoning the existing stormwater infrastructure should not be servicing multiple properties. Easements are required for infrastructure crossing property lines.
- In order to minimize number of storm sewer connections the foundation drain, the drive ramp drain, and building rooftop, may connect to site sewer under free-flow conditions. The system must be designed to ensure that drainage does not back-up into the building drain or drive ramp.
- Buildings close to the property lines would be required:
 - to tie into existing grades at the property line without modifying grades within the ROW
 - drainage cannot be directed to neighbouring properties.

Stormwater Management

Quality Control:

- Rideau Valley Conservation Authority to confirm quality control requirements.

Quantity Control:

- Site is located within the Taylor Creek Area Subwatershed Study Area draining to the Ottawa River
- When both underground and above ground storage is utilized, the release rate from the system will significantly differ than when solely one level storage is being used (i.e. greater range of head vs smaller change of head during storm event). If both levels of storage are to be accounted for then there are two options for SWM calculations: 1) use a dynamic computer model or 2) use an assumed average flow rate of half (50%) of the controlled peak flow rate of the area(s) utilizing two levels of storage.

Ministry of Environment, Conservation and Parks (MECEP)

All development applications should be considered for an Environmental Compliance Approval, under MECP regulations.

- a. A transfer of review ECA application will be required if the proposed development is multiple properties.
- b. Transfer of Review ECAs are reviewed by the MECP and may take 1-2 months for approval.
- c. Approximately \$1500 ECA application fees are collected by the City on behalf of the MECP for the proposed review.

NOTE: Site Plan Approval, or Draft Approval, is required before any Ministry of the Environment and Climate Change (MOECC) application is sent

General Service Design Comments

- Existing sewer or watermains that are not reused must be decommissioned as per City Standards. Please show all road cuts on the plans.
- The City of Ottawa Standard Detail Drawings should be referenced where possible for all work within the Public Right-of-Way.
- The application should include legal easement or joint-use and maintenance agreements.

Other

Capital Works Projects within proximity to application? Yes No

- Future asphalt resurfacing on Jasmine Cres to begin in 3-5 years. A three year moratorium is placed on future road cuts after the road resurfacing is completed. The applicant should coordinate with the City to avoid construction and timeline conflicts.

References and Resources

- As per section 53 of the Professional Engineers Act, O. Reg 941/40, R.S.O. 1990, all documents prepared by engineers must be signed and dated on the seal.
- All required plans & reports are to be provided in *.pdf format (at application submission and for any, and all, re-submissions)
- Please find relevant City of Ottawa Links to Preparing Studies and Plans below:
<https://ottawa.ca/en/city-hall/planning-and-development/information-developers/development-application-review-process/development-application-submission/guide-preparing-studies-and-plans#standards-policies-and-guidelines>
- To request City of Ottawa plan(s) or report information please contact the City of Ottawa Information Centre:
InformationCentre@ottawa.ca<mailto:InformationCentre@ottawa.ca>
(613) 580-2424 ext. 44455
- geoOttawa
<http://maps.ottawa.ca/geoOttawa/>

PLANS & STUDIES LIST

For information on preparing required studies and plans refer to:

<http://ottawa.ca/en/development-application-review-process-0/guide-preparing-studies-and-plans>

S/Z	Number of copies	ENGINEERING		S/A	Number of copies
		1. Site Servicing Plan	2. Site Servicing Brief The application should include legal easement or joint-use and maintenance agreements	Z	
		3. Grade Control and Drainage Plan	4. Geotechnical Study	Z	
		5. Composite Utility Plan	6. Groundwater Impact Study		
		7. Servicing Options Report	8. Wellhead Protection Study		
		9. Community Transportation Study and/or Transportation Impact Study / Brief	10. Erosion and Sediment Control Plan / Brief		
Z		11. Storm water Management Brief	12. Hydro-geological and Terrain Analysis		
		13. Water main Analysis	14. Noise / Vibration Study		
		15. Roadway Modification Design Plan	16. Confederation Line Proximity Study		

S – Required for Site Plan Control

Z – Required for Zoning By-Law Amendment

Ryan Robineau

From: Curtis Melanson
Sent: March 21, 2023 9:51 AM
To: Ryan Robineau
Subject: FW: Centrum Site Plan

FYI

Curtis Melanson, C.E.T.

Practice Area Lead, Land Development

T. 613.714.4621 | F. 613.836.3742 | C. 613.857.0784

c.melanson@mcintoshperry.com | www.mcintoshperry.com

McINTOSH PERRY

Turning Possibilities Into Reality

From: Charie, Kelsey <kelsey.charie@ottawa.ca>
Sent: Thursday, March 9, 2023 5:11 PM
To: Curtis Melanson <c.melanson@mcintoshperry.com>
Cc: Ryan Robineau <r.robineau@mcintoshperry.com>; Robert Freel <r.freel@mcintoshperry.com>
Subject: RE: Centrum Site Plan

Thanks Curtis,

I reviewed that SWM report and it is not terribly clear, but your suggestion of a release rate of 35.5 L/s to Brisebois and controlled flow for Tower A to Centrum makes sense to me. I tried to figure out what the existing YMCA release rate to Centrum was, but haven't been able to find anything, I can see if our Asset Management branch can help with that.

Also Natasha mentioned a Rod Price was looking for boundary conditions? Is that something I can also help with?

Kelsey

From: Curtis Melanson <c.melanson@mcintoshperry.com>
Sent: March 09, 2023 9:09 AM
To: Charie, Kelsey <kelsey.charie@ottawa.ca>
Cc: Ryan Robineau <r.robineau@mcintoshperry.com>; Robert Freel <r.freel@mcintoshperry.com>
Subject: Centrum Site Plan

CAUTION: This email originated from an External Sender. Please do not click links or open attachments unless you recognize the source.

ATTENTION : Ce courriel provient d'un expéditeur externe. Ne cliquez sur aucun lien et n'ouvrez pas de pièce jointe, excepté si vous connaissez l'expéditeur.

Hi Kelsey,

As discussed, see attached site plan. If there's any questions don't hesitate to let me know.

Cheers,

CONTRACTOR SHALL CHECK ALL DIMENSIONS ON THE WORK AND REPORT ANY DISCREPANCY TO THE CONSULTANT BEFORE PROCEEDING. THIS DRAWING IS NOT TO BE USED FOR CONSTRUCTION UNLESS AUTHORIZED IN WRITING BY CONSULTANT.

PART OF BLOCK 6 AND PART OF COMMERCIAL DRIVE
(As Closed by By-Law 90-92, Inst. L7789196) REGISTERED
PLAN 50M-165
CITY OF OTTAWA

NOTES

1. TO BE READ IN CONJUNCTION WITH DRAWINGS PREPARED BY SITE SERVING ENGINEER AND LANDSCAPE ARCHITECT. REFER TO SITE SERVICES/GRADING DRAWINGS FOR GRADING INFORMATION AND DRAINAGE.
2. FIRE ROUTES SHALL BE DESIGNED IN ACCORDANCE WITH APPLICABLE OBC REQUIREMENTS; MIN. WIDTH 6m AND MIN. TURNING RADIUS OF 12m; INTERIOR TURNING RADI OF 9m AND OUTSIDE TURNING RADI OF 15m.
3. FIRE ROUTES OVER PARKING GARAGE SHALL BE DESIGNED TO SUPPORT THE 500 KPA LOADING REQUIREMENT IDENTIFIED IN NFPA 1901.
4. FIRE ROUTES SHALL BE DESIGNED TO SUPPORT EXPECTED LOADS IMPOSED BY FIREFIGHTING EQUIPMENT AND MEET THE REQUIREMENTS OF THE CANADIAN HIGHWAY BRIDGE CODE, AND SHALL BE SURFACED IN ORDER TO BE ACCESSIBLE UNDER ALL CLIMATIC CONDITIONS.

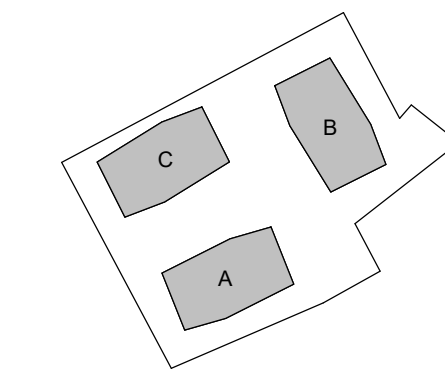

KEY PLAN

REVISION		
NO.	DATE	DESCRIPTION
1	23-03-24	ISSUED FOR SITE PLAN APPROVAL
2	24-03-13	ISSUED FOR SPA REVISIONS

LEGEND

- MAIN PEDESTRIAN ENTRY
- PEDESTRIAN ENTRY
- PEDESTRIAN EGRESS
- VEHICULAR ENTRY
- PROPOSED ELEVATION
- SIAMESE CONNECTION
- FIRE HYDRANT
- LIGHT POST
- CATCH BASIN / MAN-HOLE COVER
- FIRE ACCESS ROUTE
- OUTLINE OF UPPER TOWER FACADE
- OUTLINE OF LOWER TOWER FACADE
- OUTLINE OF PODIUM FACADE

BIKE PARKING DIAGRAMS

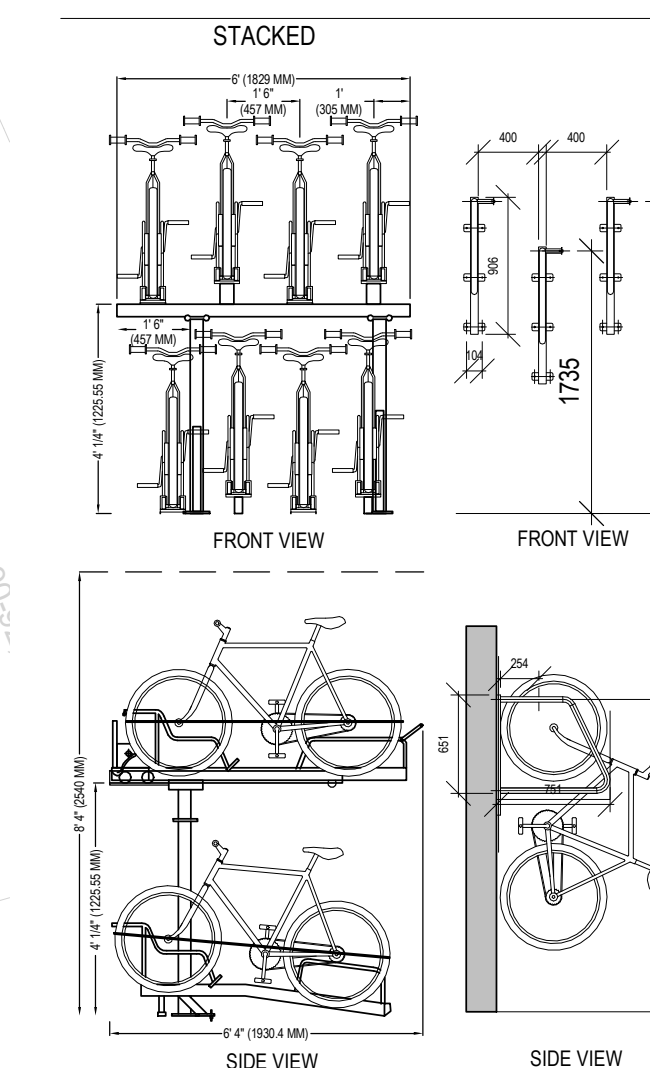

PARKING SPACE LEGEND

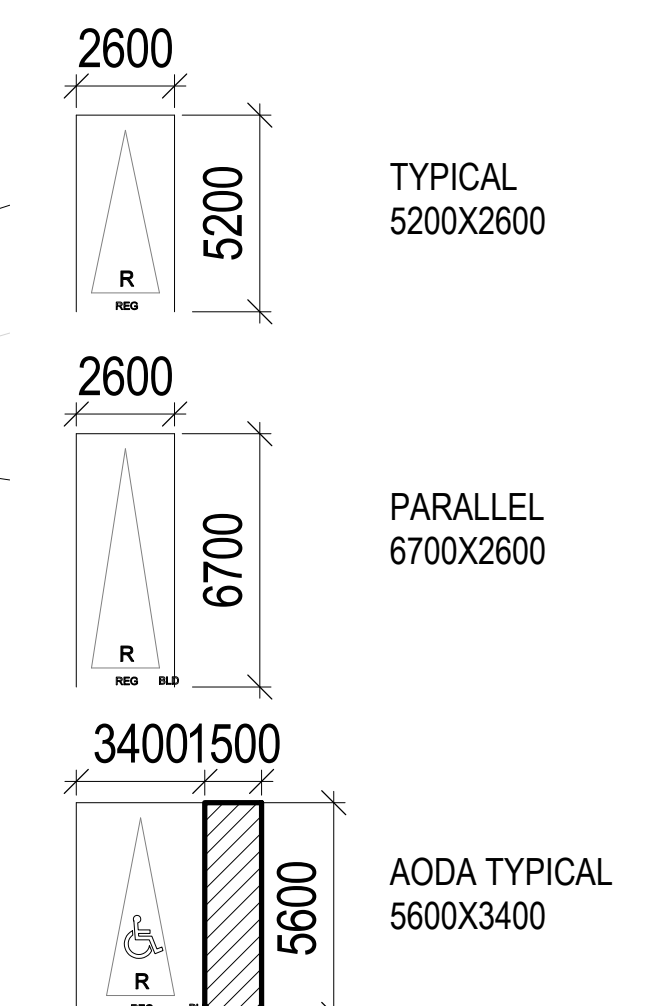

STRUCTURAL ENGINEER:

Art Engineering
171 Walgreen Rd
Carp, K0A 1L0
T/613-836-0632

MECHANICAL ENGINEER:

Mechanical Consultant
Street Address
City Post Code
T/xxxx.xxxx.xxxx F/xxxx.xxxx.xxxx

ELECTRICAL ENGINEER:

Electrical Consultant
Street Address
City Post Code
T/xxxx.xxxx.xxxx F/xxxx.xxxx.xxxx

WIND + NOISE CONSULTANT:

Gradient Wind
127 Walgreen Rd
Carp, K0A 1L0
T/613-836-0934

LANDSCAPE ARCHITECT:

J. Lennox and Associates
3332 Carling Ave
Nepean K2H 5A8
T/613-722-5168

SITE SERVICES/CIVIL ENGINEER:

McIntosh Perry
115 Walgreen Rd
Carp, K0A 1L0
T/613-836-2184

PLANNING CONSULTANT:

Fotenn
396 Cooper St Suite 300
Ottawa K2P 2H7
T/613-730-5709

TRAFFIC CONSULTANT:

CGH
13 Markham Ave
Nepean K2G 3Z1
T/343-996-2623

OWNER:

BAYVIEW GROUP

108 Chestnut Street
Toronto M5G 1R3
T/(416)-597-6368

PROJECT:

CENTRUM

265 CENTRUM BLVD
ORLÉANS, ON
K1E 3X7

SHEET CONTENTS:

SITE PLAN

PROJECT NUMBER:

2211080

DRAWING SCALE:

As indicated

DRAWN BY:

Author

CHECKED BY:

Checker

DATE:

01/19/23

SHEET NO.:

A010

REV:

2

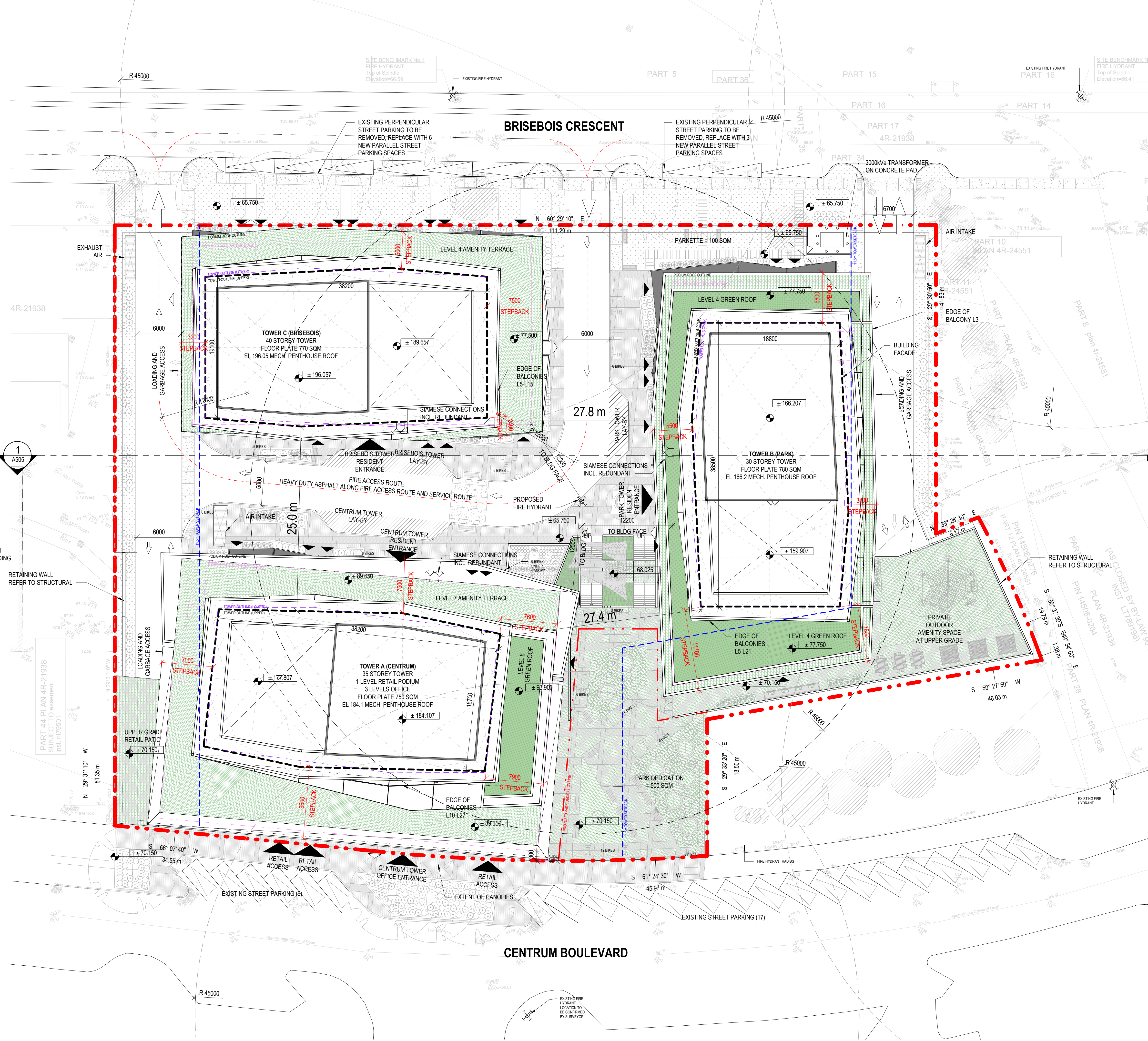

3/13/2024 1:52:45 PM A010
BIM 360/2211080 - Centrum Blvd Orleans/2211080-BH-ARCH-MASTER-R2021.rvt
SITE PLAN
PART 44 PLAN 4R-21938
SUBJECT TO ESCHEAT
INST. M79501

APPENDIX C
WATERMAIN CALCULATIONS

265 Centrum Blvd 1E Pressure Zone

ORLEANS P.S.

FOREST RIDGE P.S.

S.

SITE LOCATION

2E

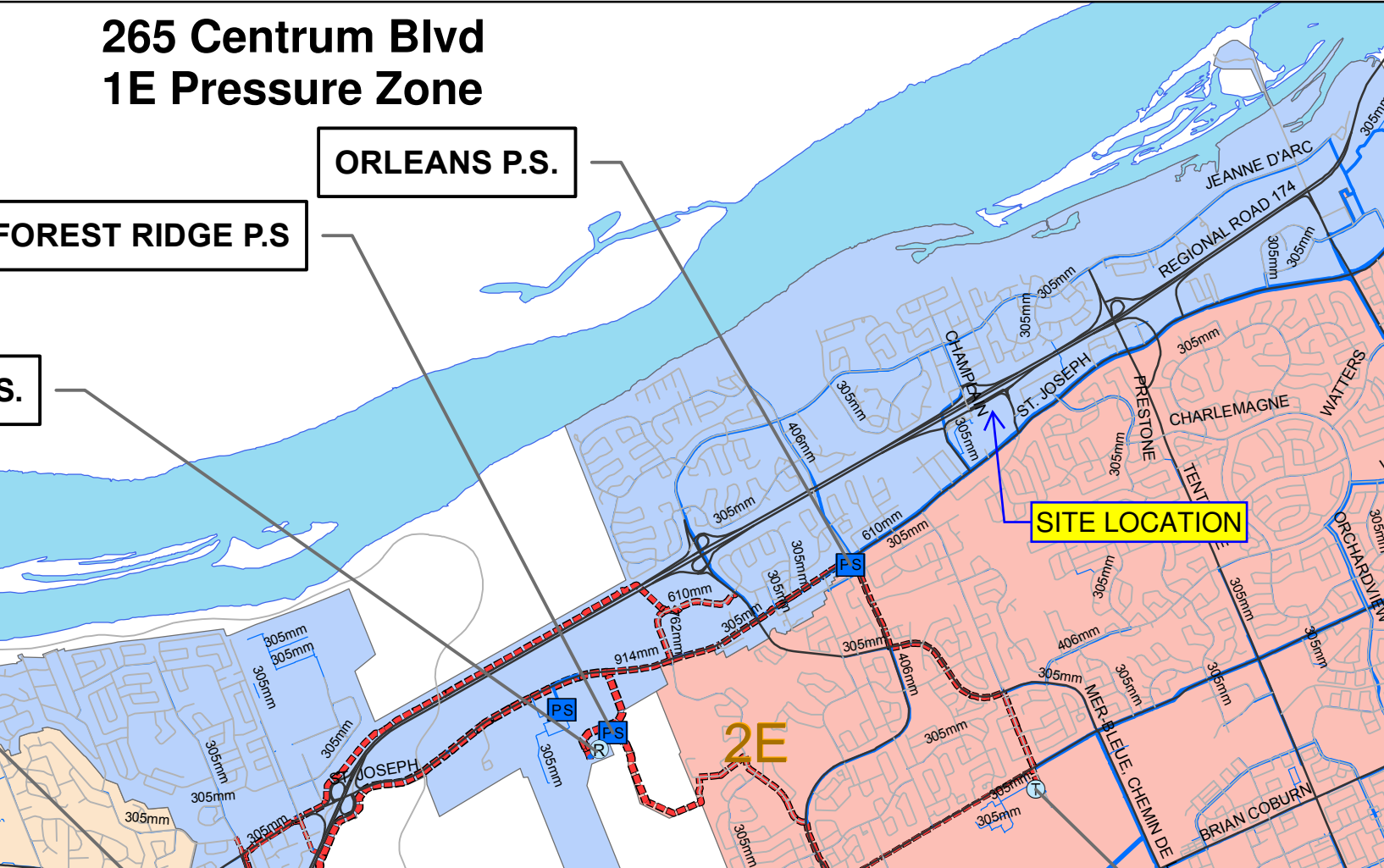

McINTOSH PERRY

000-23-3408 - 265 Centrum - Water Demands

Project:	265 Centrum
Project No.:	000-23-3408
Designed By:	RRR
Checked By:	RDF
Date:	March 15, 2024
Ste Area:	0.91 gross ha

<u>Residential</u>	NUMBER OF UNITS	UNIT RATE	
Single Family	homes	3.4	persons/unit
Semi-detached	homes	2.7	persons/unit
Townhouse	17 homes	2.7	persons/unit
Bachelor Apartment	units	1.4	persons/unit
1 Bedroom Apartment	681 units	1.4	persons/unit
2 Bedroom Apartment	375 units	2.1	persons/unit
3 Bedroom Apartment	54 units	3.1	persons/unit
Average Apartment	units	1.8	persons/unit

Total Population 1955 persons

<u>Commercial/ Institutional</u>	1136 m2
<u>Industrial - Light</u>	m2
<u>Industrial - Heavy</u>	m2

AVERAGE DAILY DEMAND

DEMAND TYPE	AMOUNT	UNITS	
Residential	280	L/c/d	
Industrial - Light	35,000	L/gross ha/d	
Industrial - Heavy	55,000	L/gross ha/d	
Shopping Centres	2,500	L/(1000m ² /d)	
Hospital	900	L/(bed/day)	
Schools	70	L/(Student/d)	
Trailer Park with no Hook-Ups	340	L/(space/d)	
Trailer Park with Hook-Ups	800	L/(space/d)	
Campgrounds	225	L/(campsite/d)	
Mobile Home Parks	1,000	L/(Space/d)	
Motels	150	L/(bed-space/d)	
Hotels	225	L/(bed-space/d)	
Tourist Commercial	28,000	L/gross ha/d	
Other Commercial	28,000	L/gross ha/d	
AVERAGE DAILY DEMAND	Residential	6.34	L/s
	Commercial/ Industrial/ Institutional	0.04	L/s

McINTOSH PERRY

MAXIMUM DAILY DEMAND

DEMAND TYPE	AMOUNT		UNITS
Residential	2.5	x avg. day	L/c/d
Industrial	1.5	x avg. day	L/gross ha/d
Commercial	1.5	x avg. day	L/gross ha/d
Institutional	1.5	x avg. day	L/gross ha/d
MAXIMUM DAILY DEMAND	Residential	15.84	L/s
	Commercial/ Industrial/ Institutional	0.06	L/s

MAXIMUM HOUR DEMAND

DEMAND TYPE	AMOUNT		UNITS
Residential	2.2	x max day	L/c/d
Industrial	1.8	x max. day	L/gross ha/d
Commercial	1.8	x max. day	L/gross ha/d
Institutional	1.8	x max. day	L/gross ha/d
MAXIMUM HOUR DEMAND	Residential	34.85	L/s
	Commercial/ Industrial/ Institutional	0.10	L/s

WATER DEMAND DESIGN FLOWS PER UNIT COUNT

CITY OF OTTAWA - WATER DISTRIBUTION GUIDELINES, JULY 2010

AVERAGE DAILY DEMAND	6.37	L/s
MAXIMUM DAILY DEMAND	15.89	L/s
MAXIMUM HOUR DEMAND	34.95	L/s

McINTOSH PERRY

000-23-3408 - 265 Centrum - Fire Underwriters Survey Tower A

Project: 265 Centrum
 Project No.: 000-23-3408
 Designed By: PRR
 Checked By: RDF
 Date: March 15, 2024

From the Fire Underwriters Survey (2020)

From Part II – Guide for Determination of Required Fire Flow Copyright I.S.O.:
 Qty of Ottawa Technical Bulletin ISTB-2018-02 Applied Where Applicable

A. BASE REQUIREMENT (Rounded to the nearest 1000 L/min)

F = 220 x C x √A Where:

F = Required fire flow in liters per minute

C = Coefficient related to the type of construction.

A = The total effective floor area in square meters (two largest adjoining floor areas plus 50% of all floors immediately above them up to a maximum of eight) in the building being considered per 2020 FUS Page 20

Floor Level	Area (m ²)	Area Applied (m ²)
L3	1782.6	1782.6
L4	1785.7	1785.7
L5	1785.9	892.9
L6	773.8	386.9
L7	1031.7	515.9
L8	771.2	385.6
L9	771.2	385.6
L10	771.2	385.6
L11	771.2	385.6
L12	771.2	385.6

A-Total Effective Floor Area (per the 2020 FUS Page 20 - Total Effective Area) 7,292.1 m²

Construction Type Non-Combustible Construction

C 0.8

* Unprotected Vertical Openings

Calculated Fire Flow

15,029.3 L/min
 15,000.0 L/min

B. REDUCTION FOR OCCUPANCY TYPE (No Rounding)

From Page 24 of the Fire Underwriters Survey:

Limited Combustible

-15%

Fire Flow

12,750.0 L/min

C. REDUCTION FOR SPRINKLER TYPE (No Rounding)

Standard Water Supply Sprinklered

-40%

Reduction

-5,100.0 L/min

D. INCREASE FOR EXPOSURE (No Rounding)

Exposure	Separation Distance (m)	Cons. of Exposed Wall	Length Exposed	Height	Length-Height	% Increase*
Exposure 1	10.1 to 20	Fire Resistive - Non Combustible (Unprotected Openings)	55	40	2200.0	8%
Exposure 2	10.1 to 20	Fire Resistive - Non Combustible (Unprotected Openings)	57	30	1710.0	8%
Exposure 3	Over 30 m	Fire Resistive - Non Combustible (Unprotected Openings)	35	2	70.0	0%
Exposure 4	10.1 to 20	Fire Resistive - Non Combustible (Unprotected Openings)	38	3	114.0	8%
						% Increase* 24%

Increase*

3,060.0 L/min

E. Total Fire Flow (Rounded to the Nearest 1000 L/min)

Fire Flow

10,710.0 L/min

Fire Flow Required**

11,000.0 L/min

* In accordance with Part II, Section 4, the Increase for separation distance is not to exceed 75%

** In accordance with Section 4 the Fire flow is not to exceed 45,000 L/min or be less than 2,000 L/min

McINTOSH PERRY

COO-23-3408 - 265 Centrum - Fire Underwriters Survey Tower B

Project: 265 Centrum
 Project No.: COO-23-3408
 Designed By: RFR
 Checked By: RDF
 Date: March 15, 2024

From the Fire Underwriters Survey (2020)

From Part II – Guide for Determination of Required Fire Flow Copyright I.S.O.:
 City of Ottawa Technical Bulletin ISTB-2018-02 Applied Where Applicable

A. BASE REQUIREMENT (Rounded to the nearest 1000 L/min)

F = 220 x C x √A Where:

F = Required fire flow in liters per minute

C = Coefficient related to the type of construction.

A = The total effective floor area in square meters (two largest adjoining floor areas plus 50% of all floors immediately above them up to a maximum of eight) in the building being considered per 2020 FUS Page 20

Floor Level	Area (m ²)	Area Applied (m ²)
L2	1225.2	1225.2
L3	1129.7	1129.7
L4	741.3	370.7
L5	787.3	393.7
L6	787.3	393.7
L7	787.3	393.7
L8	787.3	393.7
L9	787.3	393.7
L10	787.3	393.7
L11	787.3	393.7

A-Total Effective Floor Area (per the 2020 FUS Page 20 - Total Effective Area) 5,481.2 m²

Construction Type Non-Combustible Construction

C 0.8

* Unprotected Vertical Openings

Calculated Fire Flow

13,030.2 L/min
13,000.0 L/min

B. REDUCTION FOR OCCUPANCY TYPE (No Rounding)

From Page 24 of the Fire Underwriters Survey:
 Limited Combustible

-15%

Fire Flow

11,050.0 L/min

C. REDUCTION FOR SPRINKLER TYPE (No Rounding)

Standard Water Supply Sprinklered

-40%

Reduction

-4,420.0 L/min

D. INCREASE FOR EXPOSURE (No Rounding)

Exposure	Separation Distance (m)	Cons. of Exposed Wall	Length Exposed	Height	Length-Height	
Exposure 1	Over 30 m	Wood frame	5	2	10.0	0%
Exposure 2	Over 30 m	Ordinary - Mass Timber (Unprotected)	35	4	140.0	0%
Exposure 3	10.1 to 20	Fire Resistive - Non Combustible (Unprotected Openings)	35	35	1225.0	8%
Exposure 4	10.1 to 20	Fire Resistive - Non Combustible (Unprotected Openings)	28	40	1120.0	8%
						% Increase*
						16%

Increase*

1,768.0 L/min

E. Total Fire Flow (Rounded to the Nearest 1000 L/min)

Fire Flow

8,398.0 L/min

Fire Flow Required**

8,000.0 L/min

* In accordance with Part II, Section 4, the increase for separation distance is not to exceed 75%

** In accordance with Section 4 the Fire flow is not to exceed 45,000 L/min or be less than 2,000 L/min

McINTOSH PERRY

COO-23-3408 - 265 Centrum - Fire Underwriters Survey Tower C

Project: 265 Centrum
 Project No.: COO-23-3408
 Designed By: RFR
 Checked By: RDF
 Date: March 15, 2024

From the Fire Underwriters Survey (2020)

From Part II – Guide for Determination of Required Fire Flow Copyright I.S.O.:
 City of Ottawa Technical Bulletin ISTB-2018-02 Applied Where Applicable

A. BASE REQUIREMENT (Rounded to the nearest 1000 L/min)

F = 220 x C x √A Where:

F = Required fire flow in liters per minute

C = Coefficient related to the type of construction.

A = The total effective floor area in square meters (two largest adjoining floor areas plus 50% of all floors immediately above them up to a maximum of eight) in the building being considered per 2020 FUS Page 20

Floor Level	Area (m ²)	Area Applied (m ²)
L1	1126.6	1126.6
L2	864.0	864.0
L3	1126.6	563.3
L4	726.7	363.3
L5	771.0	385.5
L6	771.0	385.5
L7	771.0	385.5
L8	771.0	385.5
L9	771.0	385.5
L10	771.0	385.5

A-Total Effective Floor Area (per the 2020 FUS Page 20 - Total Effective Area) 5,230.4 m²

Construction Type Non-Combustible Construction

C 0.8

* Unprotected Vertical Openings

Calculated Fire Flow 12,728.5 L/min
 13,000.0 L/min

B. REDUCTION FOR OCCUPANCY TYPE (No Rounding)

From Page 24 of the Fire Underwriters Survey:

Limited Combustible -15%

Fire Flow 11,050.0 L/min

C. REDUCTION FOR SPRINKLER TYPE (No Rounding)

Standard Water Supply Sprinklered -40%

Reduction -4,420.0 L/min

D. INCREASE FOR EXPOSURE (No Rounding)

Exposure	Separation Distance (m)	Cons. of Exposed Wall	Length Exposed	Height	Length-Height	% Increase*
Exposure 1	Over 30 m	Wood frame	35	2	70.0	0%
Exposure 2	10.1 to 20	Fire Resistive - Non Combustible (Unprotected Openings)	35	30	1050.0	8%
Exposure 3	20.1 to 30	Fire Resistive - Non Combustible (Unprotected Openings)	38	35	1330.0	4%
Exposure 4	10.1 to 20	Fire Resistive - Non Combustible (Unprotected Openings)	38	3	114.0	8%
					% Increase*	20%

Increase* 2,210.0 L/min

E. Total Fire Flow (Rounded to the Nearest 1000 L/min)

Fire Flow 8,840.0 L/min
 Fire Flow Required** 9,000.0 L/min

* In accordance with Part II, Section 4, the Increase for separation distance is not to exceed 75%

** In accordance with Section 4 the Fire flow is not to exceed 45,000 L/min or be less than 2,000 L/min

McINTOSH PERRY

000-23-3408 - 265 Centrum - Boundary Condition Unit Conversion

Project:	265 Centrum
Project No.:	000-23-3408
Designed By:	RRR
Checked By:	PDF
Date:	March 15, 2024

Boundary Conditions Unit Conversion

Brisebois Crescent

Brisebois West Connection	Height (m)	Elevation (m)	m H ₂ O	PSI	kPa
Avg. DD	114.0	67.6	46.4	66.0	455.2
Fire Flow (183 L/s or 11,000 L/min)	92.4	67.6	24.8	35.3	243.3
Peak Hour	107.0	67.6	39.4	56.1	386.5

*Ground Elevation 67.6m

Brisebois East Connection	Height (m)	Elevation (m)	m H ₂ O	PSI	kPa
Avg. DD	114.0	67.9	46.1	65.6	452.2
Fire Flow (183 L/s or 11,000 L/min)	93.1	67.9	25.2	35.9	247.2
Peak Hour	107.0	67.9	39.1	55.6	383.6

*Ground Elevation 67.9m

Boundary Conditions 265 Centrum Blvd

Provided Information

Scenario	Demand	
	L/min	L/s
Average Daily Demand	382	6.37
Maximum Daily Demand	953	15.89
Peak Hour	2,097	34.95
Fire Flow Demand #1	11,000	183.33

Location

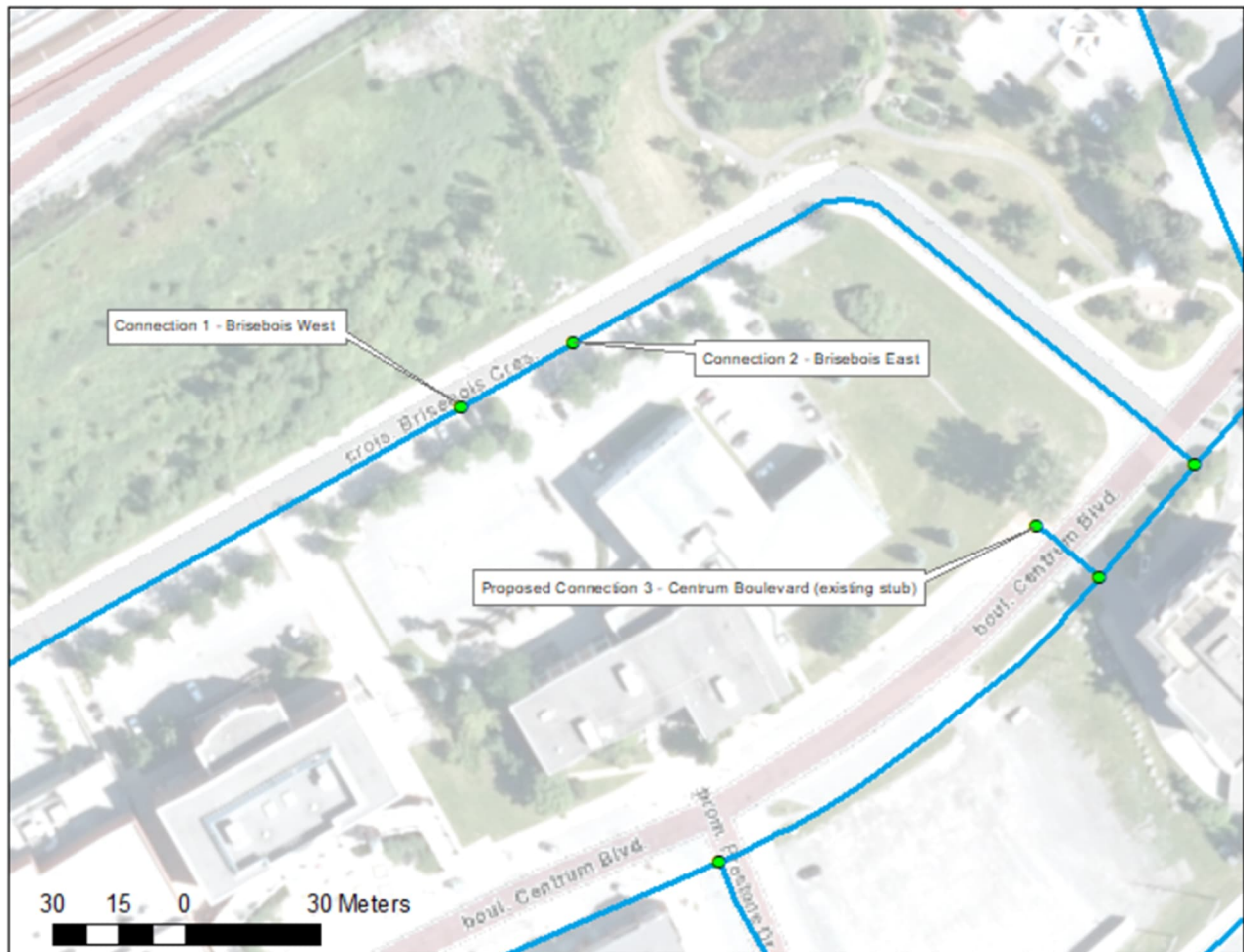

Results

Scenario 1 – Dual Connection at Brisebois Crescent

Connection 1 – Brisebois Crescent West

Demand Scenario	Head (m)	Pressure¹ (psi)
Maximum HGL	114.0	66.0
Peak Hour	107.0	56.1
Max Day plus Fire Flow	92.4	35.2

¹ Ground Elevation = 67.6 m

Connection 2 - Brisebois Crescent East

Demand Scenario	Head (m)	Pressure¹ (psi)
Maximum HGL	114.0	65.7
Peak Hour	107.0	55.8
Max Day plus Fire Flow	93.1	35.9

¹ Ground Elevation = 67.9 m

Scenario 2 – Brisebois & Centrum Boulevard Stub Connections

Connection 1 – Brisebois Crescent West

Demand Scenario	Head (m)	Pressure¹ (psi)
Maximum HGL	114.1	66.1
Peak Hour	107.5	56.7
Max Day plus Fire Flow	93.1	36.3

¹ Ground Elevation = 67.6 m

Connection 3 – Centrum Boulevard

Demand Scenario	Head (m)	Pressure¹ (psi)
Maximum HGL	114.1	64.1
Peak Hour	107.6	54.9
Max Day plus Fire Flow	105.4	51.8

¹ Ground Elevation = 69.0 m

Notes

1. 2 possible connection scenarios as stated above:
 - a. First connection scenario: requested dual connection on Brisebois Crescent on each side of isolation valve.
 - b. Second connection scenario: 1 connection at Brisebois Crescent and 1 connection on existing stub at Centrum Boulevard.
2. If first connection scenario is preferred, connection on each side of an isolation valve is required to respect The Ottawa Water Distribution Design Guideline (OWDG) – **Technical Bulletin ISTB-2021-03 Section 4.3.1:**

Industrial, commercial, institutional service areas with a basic day demand greater than 50 m³/day (0.58 L/s) and residential areas serving 50 or more dwellings shall be connected with a minimum of two watermains, separated by an isolation valve, to avoid the creation of a vulnerable service area. Individual residential facilities with a basic day demand greater than 50 m³/day shall be connected with a minimum of two water services, separated by an isolation valve, to avoid the creation of a vulnerable service area.

Disclaimer

The boundary condition information is based on current operation of the city water distribution system. The computer model simulation is based on the best information available at the time. The operation of the water distribution system can change on a regular basis, resulting in a variation in boundary conditions. The physical properties of watermains deteriorate over time, as such must be assumed in the absence of actual field test data. The variation in physical watermain properties can therefore alter the results of the computer model simulation. Fire Flow analysis is a reflection of available flow in the watermain; there may be additional restrictions that occur between the watermain and the hydrant that the model cannot take into account.

APPENDIX D
SANITARY CALCULATIONS

McINTOSH PERRY

000-23-3408 - 265 Centrum - Sanitary Demands

Project:	265 Centrum
Project No.:	000-23-3408
Designed By:	PRR
Checked By:	RDF
Date:	March 7, 2024

Site Area	0.90	Gross ha	
1 Bedroom	681		1.40 Persons per unit
2 Bedroom	375		2.10 Persons per unit
3 Bedroom	54		3.10 Persons per unit
Townhouse	17		2.70 Persons per unit
Total Population	1955	Persons	
Commercial Area	833.00	m ²	
Amenity Space	2156.00	m ²	
Office Space	3033.00	m ³	

DESIGN PARAMETERS

Institutional/Commercial Peaking Factor	1	* Check technical bulleting (Either use 1.0 or 1.5)
Residential Peaking Factor	3.07	* Using Harmon Formula = $1+(14/(4+P^{0.5}))^{*}0.8$ where P = population in thousands, Harmon's Correction Factor = 0.8
Mannings coefficient (n)	0.013	
Demand (per capita)	280	L/ day
Infiltration allowance	0.33	L/s/ Ha

EXTRANEOUS FLOW ALLOWANCES

Infiltration / Inflow	Flow (L/s)
Dry	0.04
Wet	0.25
Total	0.30

AVERAGE DAILY DEMAND

DEMAND TYPE	AMOUNT	UNITS	POPULATION / AREA	Flow (L/s)
Residential	280	L/ c/ d	1955	6.34
Industrial - Light**	35,000	L/gross ha/d		0
Industrial - Heavy**	55,000	L/gross ha/d		0
Commercial / Amenity	2,800	L/(1000m ² /d)	2989.00	0.10
Hospital	900	L/(bed/day)		0
Schools	70	L/(Student/d)		0
Trailer Parks no Hook-Ups	340	L/(space/d)		0
Trailer Park with Hook-Ups	800	L/(space/d)		0
Campgrounds	225	L/(campsite/d)		0
Mobile Home Parks	1,000	L/(Space/d)		0
Motels	150	L/(bed-space/d)		0
Hotels	225	L/(bed-space/d)		0
Office	75	L/7.0m ² /d	3033.00	0.38
Tourist Commercial	28,000	L/gross ha/d		0
Other Commercial	28,000	L/gross ha/d		0

McINTOSH PERRY

AVERAGE RESIDENTIAL FLOW	6.34	L/s
PEAK RESIDENTIAL FLOW	19.48	L/s
AVERAGE ICI FLOW	0.47	L/s
PEAK INSTITUTIONAL/ COMMERCIAL FLOW	0.47	L/s
PEAK INDUSTRIAL FLOW	0.00	L/s
TOTAL PEAK ICI FLOW	0.47	L/s

TOTAL SANITARY DEMAND

TOTAL ESTIMATED AVERAGE DRY WEATHER FLOW	6.85	L/s
TOTAL ESTIMATED PEAK DRY WEATHER FLOW	20.00	L/s
TOTAL ESTIMATED PEAK WET WEATHER FLOW	20.25	L/s

SANITARY SEWER DESIGN SHEET

PROJECT: CCO-23-3408
 LOCATION: 265 Centrum



LOCATION				RESIDENTIAL									ICI AREAS						INFILTRATION ALLOWANCE			FLOW		SEWER DATA								
1	2	3	4	5	6	7	8	9	10	11	12	13	14	15	16	17	18	19	20	21	22	23	24	25	26	27	28	29	30	31		
STREET	AREA ID	FROM MH	TO MH	UNIT TYPES				AREA (ha)	POPULATION		PEAK FACTOR	PEAK FLOW (L/s)	AREA (ha)						PEAK FLOW (L/s)	AREA (ha)		FLOW (L/s)	DESIGN FLOW (L/s)	CAPACITY (L/s)	LENGTH (m)	DIA (mm)	SLOPE (%)	VELOCITY (full) (m/s)	AVAILABLE CAPACITY			
				1-BED	2-BED	TH	3-BED		IND	CUM			INSTITUTIONAL		COMMERCIAL		OFFICE			IND	CUM								IND	CUM	L/s	(%)
Brisebois Cres.		BLDG	MH1A	681	375	17	54	0.90	1954.2	1954.2	3.07	19.47		0.00	0.30	0.30	0.30	0.30	0.30	0.47	0.90	0.90	0.30	20.2	34.22	1.17	200	1.00	1.055	13.97	40.84	
		MH1A	EX Sewer						0.0	1954.2	3.07	19.47		0.00					0.30		0.90	0.30	20.2	34.22	10.18	200	1.00	1.055	13.97	40.84		
Design Parameters:				Notes:									Designed: FFR						No.			Revision						Date				
Residential				ICI Areas									Checked: AM																			
1-Bed	1.4	p/p/u																														
2-BED	2.1	p/p/u	INST	28,000	L/Ha/day																											
TH/SD	2.7	p/p/u	COM	28,000	L/Ha/day																											
3-BED	3.1	p/p/u	OFFICE	75	L/7.0m ² /d																											
Other	60	p/p/Ha																														
				4. Residential Peaking Factor: Harmon Formula = 1+(14/(4+P*0.5)*0.8) where P = population in thousands									Project No.: CCO-23-3408															Sheet No: 1 of 1				

265 Centrum Blvd

Cumberland Collector

East Urban Community Collection Area



SANITARY SEWER DESIGN SHEET

NOVATECH
ENGINEERING
CONSULTANTS LTD.

PROJECT: 106011
DESIGNED BY: DB
CHECKED BY: JA
DATE: 27-Jul-07
REVISED: 19-Oct-07
REVISED: 29-Nov-07
ISSUED FOR MOE APPROVAL: 15-Jan-08

PROJECT: Orleans Town Centre (West)
DEVELOPER: Public-Private Partnership

EA	LOCATION			INDIVIDUAL AREA (ha.)	CUMULATIVE AREA (ha.)	PEAK FACTOR M	POPULATION FLOW	INFILTRATION FLOW	PEAK DESIGN FLOW	PROPOSED SEWER								
	LAND USE	FROM MH	TO MH				Q (p) (L/s)	Q (i) (L/s)	Q (d) (L/s)	LENGTH (m)	PIPE SIZE (mm)	PIPE ID (mm)	TYPE OF PIPE	GRADE %	CAPACITY (L/s)	FULL FLOW VELOCITY (m/s)	Qpeak/Qcap	Depth of Flow/ Diameter
							0.81	0.37	1.18									
	Morguard Lands/Light Industrial	101	103	1.330	1.330	1.5	2.31	0.53	2.84									
	Future Hotel	101	103	0.580	1.910	4.0	3.43	0.90	4.32	111.0	250	251.46	DR 35	0.40	38.2	0.77	0.11	0.26
	Proposed Commercial	101	103	1.290	3.200	1.5	3.92	1.12	5.04									
	Future Light Industrial	103	105	0.810	4.010	1.5	4.48	1.30	5.78	120.0	250	251.46	DR 35	0.24	29.6	0.60	0.20	0.35
	Future Commercial	103	105	0.640	4.650	1.5	4.99	1.47	6.46	87.9	250	251.46	DR 35	0.25	30.2	0.61	0.21	0.36
	Future Commercial	105	107	0.590	5.240	1.5	4.99	1.47	6.46	7.3	250	251.46	DR 35	0.28	32.0	0.64	0.20	0.35
		107	109	0.000	5.240	1.5												
							6.96	0.14	7.10	58.7	250	251.46	DR 35	4.50	128.1	2.58	0.06	0.19
	Future Residential/Condo	113	111	0.490	0.490	4.0	6.96	0.14	7.10	8.4	250	251.46	DR 35	0.24	29.6	0.60	0.24	0.38
		111	109		0.490	4.0												
							11.95	1.62	13.56	24.6	250	251.46	DR 35	0.50	42.7	0.66	0.32	0.45
	Open Space	109	EX 1	0.050	5.780													
							11.95	1.62	13.56	47.9	250	251.46	DR 35	0.13	21.8	0.44	0.62	0.66
	Outlet	EX 1	EX 2		5.780		11.95	1.62	13.56	60.7	250	251.46	DR 35					
	Outlet	EX 2	EX 3		5.780													

Notes:

1. $Q(d) = Q(p) + Q(i)$, where

Q(d) = Design Flow (L/s)
Q(p) = Population Flow (L/s)
Q(i) = Infiltration Flow (L/s)

2. $Q(i) = 0.28 \text{ L/s/ha}$

3. Population Flow Assumptions:

Area A, D
Light Industrial
35,000 L/ha/day
Peak Factor = 1.5
(from OSDG)

Area B
Hotel
180 L/person/day
100 rooms
1.8 persons/room
Peak Factor=4
(from OSDG)

Area C, E, F
Commercial
50,000 L/ha/day
Peak Factor = 1.5
(from OSDG)

Area G
Senior's Residence
400 L/person/day
140 units
1.8 persons/unit
Peak factor=4
(from OSDG)

Senior's Condo's
275 L/person/day
100 units
1.8 persons/unit
Peak Factor=4
(from OSDG)

A = Cumulative Area (ha.)

Min pipe size 250mm @ min. slope 0.24% as per City of Ottawa Sewer Design Guidelines (OSDG)



APPENDIX E
PRE-DEVELOPMENT DRAINAGE PLAN

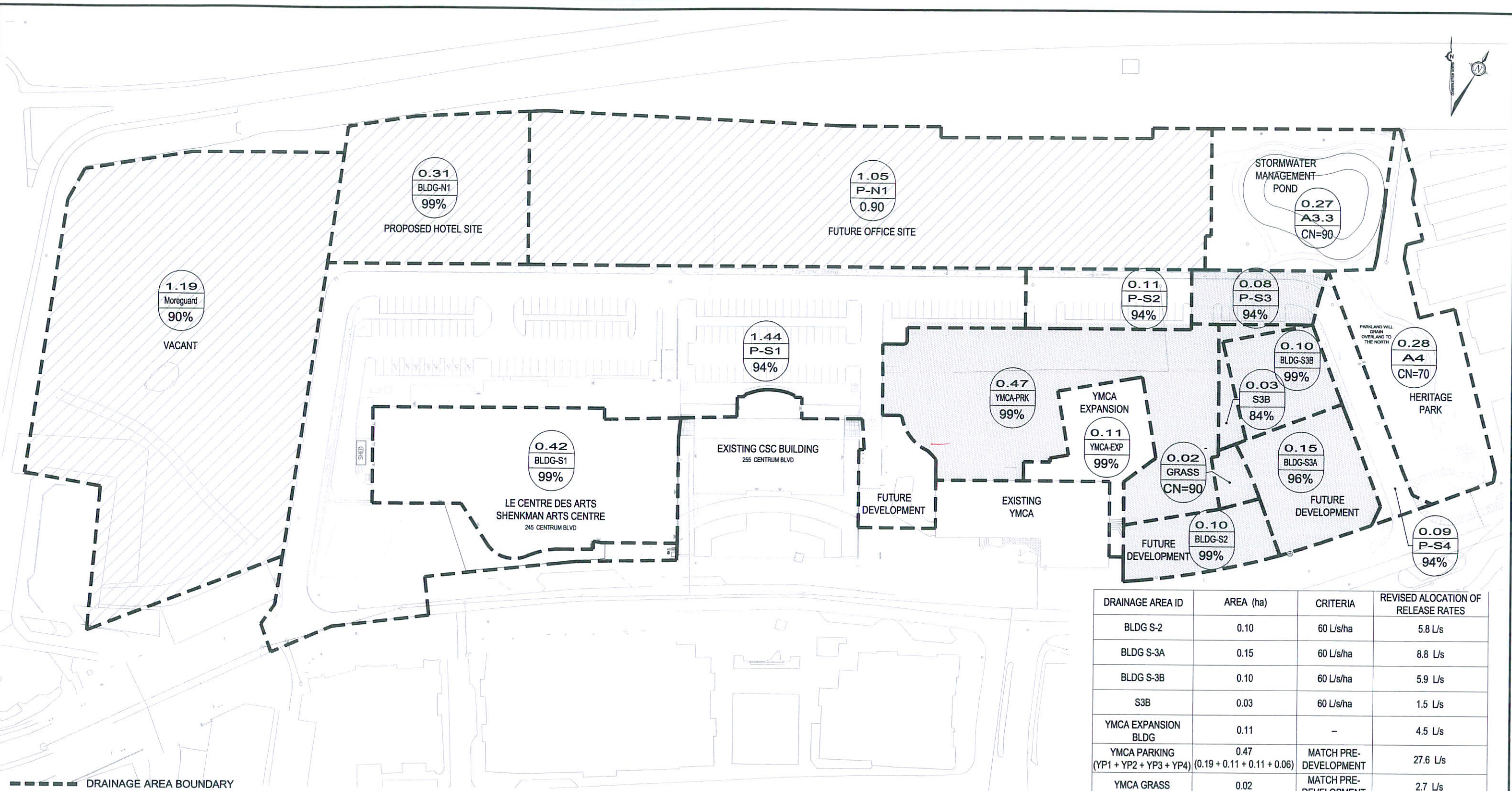

DRAINAGE AREA ID	AREA (ha)	CRITERIA	REVISED ALLOCATION OF RELEASE RATES
BLDG S-2	0.10	60 L/s/ha	5.8 L/s
BLDG S-3A	0.15	60 L/s/ha	8.8 L/s
BLDG S-3B	0.10	60 L/s/ha	5.9 L/s
S3B	0.03	60 L/s/ha	1.5 L/s
YMCA EXPANSION BLDG	0.11	-	4.5 L/s
YMCA PARKING (YP1 + YP2 + YP3 + YP4) (0.19 + 0.11 + 0.11 + 0.06)	0.47	MATCH PRE-DEVELOPMENT	27.6 L/s
YMCA GRASS	0.02	MATCH PRE-DEVELOPMENT	2.7 L/s
TOTAL	0.98	-	58.5 L/s

- DRAINAGE AREA BOUNDARY
- MAJOR SYSTEM OVERLAND FLOW
- DRAINAGE AREA (Hectares)
CATCHMENT ID
% IMPERVIOUS (STANDHYD)
SOIL CN (NASHYD)
- LANDS TRIBUTARY TO THE NORTH SEWER
- PROPOSED YMCA/YWCA EXPANSION
- DRAINAGE AREAS REVISED BY YMCA EXPANSION APPLICATION

No.	REVISION	DATE	BY
3	REVISED PER CITY COMMENTS	JULY 22/10	MER
2	REVISED FOR SITE PLAN APPROVAL	JUNE 7/10	MER
1	ISSUED WITH REPORT	NOV 12/09	MER

NOVATECH
ENGINEERING
CONSULTANTS LTD.
ENGINEERS & PLANNERS

Suite 200, 240 Michael Cowpland Drive
Ottawa, Ontario, Canada
K2M 1P6

Telephone (613) 254-9643
Facsimile (613) 254-5867
Email: novainfo@novatech-eng.com

YMCA EXPANSION
REVISED DRAINAGE AREAS

JULY 2010 109038 FIGURE 3

M:\2009\109038\CADD\Design\109038-SWM.dwg, SWM - OVERALL FIG 3, Jul 22, 2010 - 4:20pm, rancher

- A small portion of the YMCA building roof was accounted for twice in the November 2009 report; this error has been fixed and results in a lower peak overflow and runoff volume from the building roof to the YMCA parking during large storm events.
 - Reduction in peaks flows (July 1, 1979 storm): 33 L/s in November 2009 to 24 L/s in July 2010.
 - Reduction in runoff volumes (July 1, 1979 storm): 41.3 m³ in November 2009 to 33.1 m³ in July 2010.
- Due to the revised site plan, the area of the YMCA parking lot, and thus the tributary drainage area to the superpipe, has been reduced from 0.55 ha in 2009 to 0.52 ha in 2010. This reduction in drainage area translates to a reduction in runoff to the superpipe.
 - Reduction in peaks flows (July 1, 1979 storm): 192 L/s in November 2009 to 164 L/s in July 2010.
 - Reduction in runoff volumes (July 1, 1979 storm): From 483 m³ in November 2009 to 409 m³ in July 2010.
- The modeling completed for the November 2009 report used a lower overall release rate (50.3 L/s) than the approved release rate for the site (58.5 L/s). The release rates of the various catchment areas have been revised, and the overall release rate has been increased to 57.9 L/s.

The changes in peak flows and storage volumes are summarised in Table 5.

Table 5: Proposed Release Rates and Storage Volumes

Area ID	Area (ha)	Release Rate		Storage	
		(L/s)	(L/s/ha)	(m ³)	(m ³ /ha)
November 2009					
BLDG S2	0.11	4.0	40.0	62	564
BLDG S3	0.23	9.0	40.0	126	548
YMCA BLDG	0.13	5.2	40.0	33	254
YMCA Parking	0.55	32.1	58.4	266	484
Total	1.02	50.3	49.3	487	477
July 2010					
BLDG S2	0.10	6.0	60.0	41.0	410
BLDG S3A	0.15	9.0	60.0	62.7	418
BLDG S3B	0.10	6.0	60.0	41.5	415
Surface S3B	0.03	2.0	60.0	10.5	400
YMCA BLDG	0.11	4.5	41.0	36.0	327
YMCA Parking	0.47	27.4	58.3	204.3	434
YMCA Grass*	0.02	3.0	150.0	5.7	285
Total	0.98	57.9	59.1	401.7	409.9

* This area is currently a grassed picnic area. The storage required shown in the table (5.7 m³) reflects storage required to maintain the pre-development release rate (3.0 L/s) should this area paved in the future.

APPENDIX F
POST-DEVELOPMENT DRAINAGE PLAN

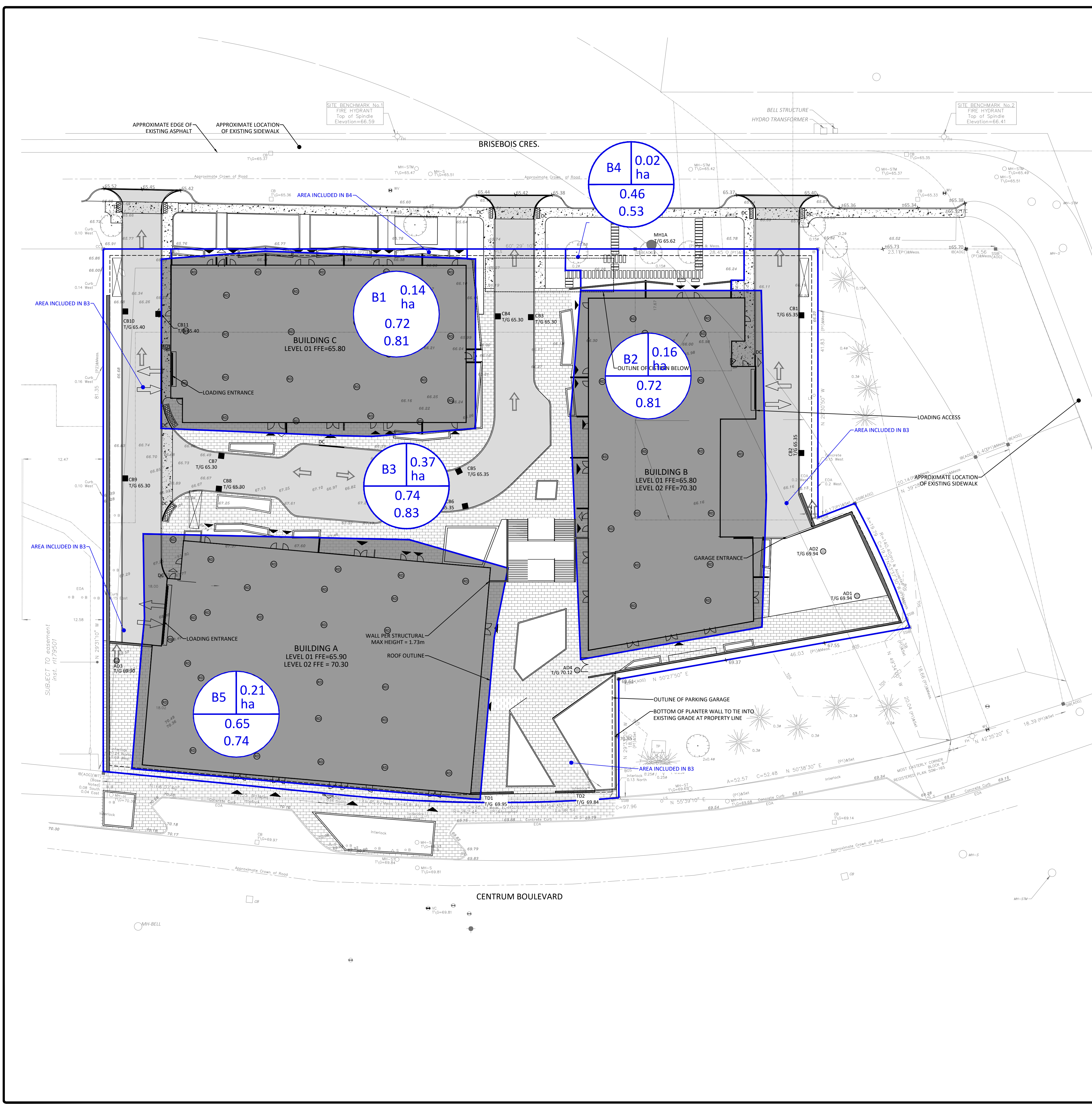

GENERAL NOTES

1. THE ORIGINAL TOPOGRAPHY, GROUND ELEVATION AND SURVEY DATA SHOWN ARE SUPPLIED FOR INFORMATION PURPOSES ONLY, AND IMPLY NO GUARANTEE OF ACCURACY. IT SHALL BE THE RESPONSIBILITY OF THE CONTRACTOR TO VERIFY ALL INFORMATION SHOWN.
2. THIS PLAN IS NOT A CADASTRAL SURVEY SHOWING LEGAL PROPERTY BOUNDARIES AND EASEMENTS. THE PROPERTY BOUNDARIES SHOWN HEREON HAVE BEEN DERIVED INFORMATION SUPPLIED BY ANNIS, O'SSULIVAN, VOLLEBEK LTD. (JOB NO. 22372-23) AND CANNOT BE RELIED UPON TO BE ACCURATE OR COMPLETE. THE PRECISE LOCATION OF THE CURRENT PROPERTY BOUNDARIES AND EASEMENTS CAN ONLY BE DETERMINED BY AN UP-TO-DATE LAND TITLES SEARCH AND A SUBSEQUENT CADASTRAL SURVEY PERFORMED AND CERTIFIED BY AN ONTARIO LAND SURVEYOR.
3. THE CONTRACTOR IS TO OBTAIN AND PAY FOR ALL NECESSARY PERMITS AND APPROVALS FROM THE CITY BEFORE COMMENCING CONSTRUCTION.
4. THE CONTRACTOR IS RESPONSIBLE FOR ALL LAYOUT.
5. THE CONTRACTOR IS TO DETERMINE THE EXACT LOCATION, SIZE, MATERIAL AND ELEVATION OF ALL EXISTING UTILITIES PRIOR TO COMMENCING CONSTRUCTION. PROTECT AND ASSUME ALL RESPONSIBILITY FOR EXISTING UTILITIES WHETHER OR NOT SHOWN ON THESE DRAWINGS. IF THERE IS ANY DISCREPANCY THE CONTRACTOR IS TO NOTIFY THE ENGINEER PROMPTLY.
6. RESTORE ALL TRENCHES AND SURFACES OF PUBLIC ROAD ALLOWANCES TO CONDITION EQUAL OR BETTER THAN ORIGINAL CONDITION AND TO THE SATISFACTION OF THE CITY AUTHORITIES.
7. EXCAVATE AND DISPOSE OF ALL EXCESS EXCAVATED MATERIAL, SUCH AS ASPHALT, CURBING AND DEBRIS, OFF SITE AS DIRECTED BY THE ENGINEER AND THE CITY.
8. TOPSOIL TO BE STRIPPED AND STOCKPILED FOR REHABILITATION. CLEAN FILL TO BE PLACED IN FILL AREAS AND COMPACTED TO 95% STANDARD PROCTOR DENSITY.
9. ALL DISTURBED AREAS TO BE RESTORED TO ORIGINAL CONDITION OR BETTER UNLESS OTHERWISE SPECIFIED.
10. THE CONTRACTOR SHALL BE RESPONSIBLE FOR ALL TRAFFIC CONTROL AND SAFETY MEASURES DURING THE CONSTRUCTION PERIOD, INCLUDING THE SUPPLY, INSTALLATION, AND REMOVAL OF ALL NECESSARY SIGNAGE, DELINEATORS, MARKERS AND BARRIERS.
11. DO NOT ALTER GRADING OF THE SITE WITHOUT PRIOR APPROVAL OF THE ENGINEER/CITY.
12. ALL ROADWAY, PARKING LOT, AND GRADING WORKS TO BE UNDERTAKEN IN ACCORDANCE WITH CITY STANDARDS AND SPECIFICATIONS. THE CONTRACTOR IS TO PROVIDE POSITIVE DRAINAGE AWAY FROM THE BUILDING.
13. CONTACT THE CITY FOR INSPECTION OF ROUGH GRADING OF PARKING LOTS, ROADWAYS AND LANDSCAPED AREAS PRIOR TO PLACEMENT OF ASPHALT AND TOPSOIL. ALL DEFICIENCIES NOTED SHALL BE RECTIFIED TO THE CITY'S SATISFACTION PRIOR TO PLACEMENT OF ANY ASPHALT, TOPSOIL, SEED & MULCH AND/OR SOO.
14. ALL DIMENSIONS AND INVERTS MUST BE VERIFIED PRIOR TO CONSTRUCTION, IF THERE IS ANY DISCREPANCY THE CONTRACTOR IS TO NOTIFY THE ENGINEER PROMPTLY.
15. ELECTRICAL, GAS, TELEPHONE AND TELEVISION SERVICE LOCATIONS ARE SUBJECT TO THE INDIVIDUAL AGENCY:
 - GAS SERVICE - ENBRIDGE,
 - TELEPHONE SERVICE - BELL CANADA,
 - TELEVISION SERVICE - ROGERS.
16. INSTALLATION TO BE IN ACCORDANCE WITH CURRENT CODES AND STANDARDS OF APPROVAL AGENCIES HYDRO ONE, BELL AND THE CITY.
17. CONTRACTOR TO ENSURE ALL APPLICABLE OPS SPECIFICATIONS ARE FOLLOWED DURING CONSTRUCTION
18. ALL PROPOSED CURB TO BE CONCRETE BARRIER CURB UNLESS OTHERWISE SPECIFIED.
19. THIS PLAN MUST BE READ IN CONJUNCTION WITH THE GEOTECHNICAL INVESTIGATION COMPLETED BY YURI MENDEZ ENGINEERING, DATED MAY 07, 2022.

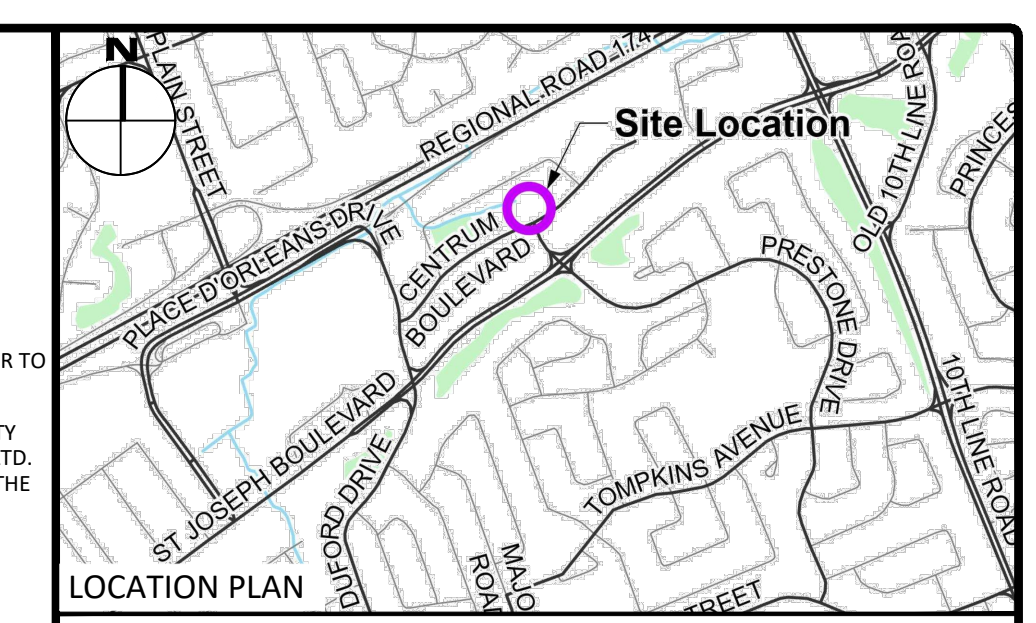

LEGEND

CONCRETE BARRIER CURB	LIMIT OF CONSTRUCTION
INTERLOCK CONCRETE PER LANDSCAPE	DRAINAGE SWALE
CONCRETE SIDEWALK	DRAINAGE DITCH
PROPOSED ASPHALT	SLOPING AT 3:1 UNLESS SPECIFIED
CS/BH T/G	95.50 SURFACE ELEVATION
CS/BMH T/G	95.50 SWALE ELEVATION
CBH T/G	X7/W95.50 TOP OF WALL ELEVATION
MH/A T/G	X/W94.25 BOTTOM OF WALL ELEVATION
HYD B/F	OVERLAND FLOW ROUTE
WATER VALVE	SILT FENCE BARRIER
WATER METER	INLET SEDIMENT CONTROL DEVICE PER DETAIL
REMOTE WATER METER	CONSTRUCTION MUD MAT
LOCATION OF FIRE DEPARTMENT CONNECTION	PROPOSED TWSI PER CITY SC7.3
	ROOF DRAIN LOCATION PER ARCHITECTURAL

FOR REVIEW ONLY
NOT FOR CONSTRUCTION

No.	Revisions	Date
2	ISSUED FOR SITE PLAN CONTROL	2024-03-19
1	ISSUED FOR SITE PLAN CONTROL	2023-03-22

Check and verify all dimensions before proceeding with the work. Do not scale drawings.

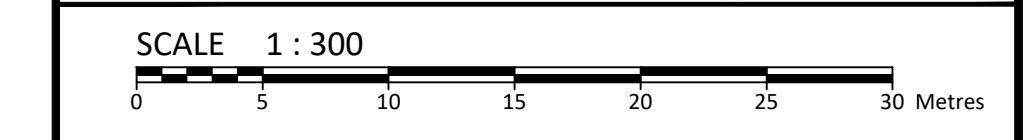

McINTOSH PERRY
115 Walgreen Road, RR3, Carp, ON K0A 1L0
Tel: 613-836-2184 Fax: 613-836-3742
www.mcintoshperry.com

Client: **BAYVIEW ORLEANS INC**
108 CHESTNUT STREET,
TORONTO, ON M5G 1R3

Project: **MIXED-USE DEVELOPMENT**
265 CENTRUM BOULEVARD

Ottawa ON

Drawing Title: **POST-DEVELOPMENT DRAINAGE PLAN**

Scale: 1:300 Project Number: CCO-23-3408

Drawn By: R.R.R. Checked By: A.M. Designed By: R.R.R.

Project Number: CCO-23-3408 Drawing Number: POST

FILENAME: U:\Information\2023\CCO-23-3408\Drawings\CCO-23-3408_Presentation.dwg
 DATE SAVED: Thursday, March 07, 2024 1:54:54 PM
 LAST PLOTTED: Tuesday, March 19, 2024 10:58:52 AM
 PLOTTER: HP DesignJet T1100e

D02-02-23-0021, D07-12-23-0033

APPENDIX G
STORMWATER MANAGEMENT CALCULATIONS

McINTOSH PERRY

CO-23-3408 - 256 Centrum - SWM Calculations

1 of 10

Tc (min)	Intensity (mm/hr)	
	5-Year	100-Year
10	104.2	178.6

C-Values	
Impervious	0.90
Gravel	0.60
Pervious	0.20

Post-Development Runoff Coefficient

Drainage Area	Impervious Area (m ²)	Gravel (m ²)	Pervious Area (m ²)	Average C (5-year)	Average C (100-year)	
B1	1,002	0	350	0.72	0.81	Building C Roof
B2	1,206	0	406	0.72	0.81	Building B Roof
B3	2,884	0	833	0.74	0.83	Attenuated Cistern
B4	86	0	142	0.46	0.53	Unattenuated
B5	1,351	0	735	0.65	0.74	Building A Roof

Post-Development Runoff Calculations

Drainage Area	Area (ha)	C 5-Year	C 100-Year	Tc (min)	Q (L/s)		
					5-Year	100-Year	
B1	0.14	0.72	0.81	10	28.15	54.08	Building C Roof
B2	0.16	0.72	0.81	10	33.80	64.92	Building B Roof
B3	0.37	0.74	0.83	10	80.01	153.50	Attenuated Cistern
B4	0.02	0.46	0.53	10	3.06	6.02	Unattenuated
B5	0.21	0.65	0.74	10	39.48	76.18	Building A Roof
Total	0.90				184.49	354.70	

McINTOSH PERRY

CO-23-3408 - 256 Centrum - SWM Calculations

2 of 10

Drainage * Area	Area (ha)	Q (L/s)
		100-Year
YMCA-Expansion	0.11	4.50
YMCA-Grass	0.02	3.00
YMCA-Parking	0.47	27.40
* Brisebois Total	0.60	34.90
** Centrum Total	-	8.52

* Drainage Areas and Release Rates From Novatech 265 Centrum Serviceability and Stormwater Management Report Rev. July 26, 2010. Peak runoff to Brisebois to match peak existing runoff to Brisebois per Novatech report.

** Drainage to Centrum to be restricted to peak attenuated flows from Building A Roof per coordination with City Staff

Post-Development Restricted Runoff Calculations

Drainage Area	Unrestricted Flow (L/S)		Restricted Flow (L/S)		Storage Required (m ³)		Storage Provided (m ³)	
	5-year	100-Year	5-Year	100-Year	5-Year	100-Year	5-Year	100-Year
B1	28.15	54.08	7.50	7.89	13.8	35.9	18.8	37.6
B2	33.80	64.92	5.40	5.68	21.8	52.7	22.6	58.8
B3	80.01	153.50	7.93	15.22	22.5	119.3	119.3	119.3
B4	3.06	6.02	3.06	6.02	-	-	-	-
Brisebois Total	145.01	278.51	23.89	34.80	58.05	207.88	160.68	215.65
B5	39.48	76.18	8.52	8.52	21.7	56.5	30.4	65.9
Centrum Total	39.48	76.18	8.52	8.52	21.74	56.46	30.40	65.86

McINTOSH PERRY

CO-23-3408 - 256 Centrum - SWM Calculations

3 of 10

Storage Requirements for Area B1

5-Year Storm Event

Tc (min)	I (mm/hr)	Runoff (L/s) B1	Allowable Outflow (L/s)	Runoff to be Stored (L/s)	Storage Required (m ³)
10	104.2	28.15	7.50	20.65	12.39
20	70.3	18.98	7.50	11.48	13.78
30	53.9	14.57	7.50	7.07	12.73
40	44.2	11.94	7.50	4.44	10.65
50	37.7	10.17	7.50	2.67	8.02

Maximum Storage Required 5-year = 14 m³

100-Year Storm Event

Tc (min)	I (mm/hr)	Runoff (L/s) B1	Allowable Outflow (L/s)	Runoff to be Stored (L/s)	Storage Required (m ³)
10	178.6	54.08	7.89	46.20	27.72
20	120.0	36.33	7.89	28.44	34.13
30	91.9	27.83	7.89	19.94	35.89
40	75.1	22.76	7.89	14.87	35.70
50	64.0	19.37	7.89	11.48	34.45
60	55.9	16.93	7.89	9.04	32.55
70	49.8	15.08	7.89	7.19	30.21
80	45.0	13.63	7.89	5.74	27.55
90	41.1	12.45	7.89	4.56	24.65
100	37.9	11.48	7.89	3.59	21.56

Maximum Storage Required 100-year = 36 m³

5-Year Storm Event Storage Summary

Roof Storage			
Location	Area*	Depth	Volume (m ³)
Roof	751.54	0.025	18.79

Storage Available (m³) = 18.79
Storage Required (m³) = 13.78

100-Year Storm Event Storage Summary

Roof Storage			
Location	Area*	Depth	Volume (m ³)
Roof	751.54	0.050	37.58

Storage Available (m³) = 37.58
Storage Required (m³) = 35.89

* Area is 75% of the total roof area

McINTOSH PERRY

Roof Drain Flow B1

Roof Drains Summary		
Type of Control Device	Watts Drainage - Accutrol Weir	
Number of Roof Drains	25	
	5-Year	100-Year
Rooftop Storage (m ³)	18.79	37.58
Storage Depth (m)	0.025	0.050
Flow (Per Roof Drain) (L/s)	0.30	0.32
Total Flow (L/s)	7.50	7.89

Flow Rate Vs. Build-Up (One Weir-Fully Closed)	
Depth (mm)	Flow (L/s)
15	0.18
20	0.24
25	0.30
30	0.32
35	0.32
40	0.32
45	0.32
50	0.32
55	0.32

* Roof Drain model to be Accutrol Weirs, See attached sheets

* Roof Drain Flow information taken from Watts Drainage website

CALCULATING ROOF FLOW EXAMPLES

1 roof drain during a 5 year storm
 elevation of water = 15mm
 Flow leaving 1 roof drain = (1 x 0.18 L/s) = 0.18 L/s

1 roof drain during a 100 year storm
 elevation of water = 50mm
 Flow leaving 1 roof drain = (1 x 0.32 L/s) = 0.32 L/s

4 roof drains during a 5 year storm
 elevation of water = 15mm
 Flow leaving 4 roof drains = (4 x 0.18L/s) = 0.72 L/s

4 roof drains during a 100 year storm
 elevation of water = 50mm
 Flow leaving 4 roof drains = (4 x 0.32 L/s) = 1.28 L/s

Roof Drain Flow		
Flow (l/s)	Storage Depth (mm)	Drains Flow (l/s)
0.18	15	4.50
0.24	20	6.00
0.30	25	7.50
0.32	30	7.89
0.32	35	7.89
0.32	40	7.89
0.32	45	7.89
0.32	50	7.89
0.32	55	7.89
0.32	60	7.89
0.32	65	7.89
0.32	70	7.89
0.32	75	7.89
0.32	80	7.89
0.32	85	7.89
0.32	90	7.89
0.32	95	7.89
0.32	100	7.89
0.32	105	7.89
0.32	110	7.89
0.32	115	7.89
0.32	120	7.89
0.32	125	7.89
0.32	130	7.89
0.32	135	7.89
0.32	140	7.89
0.32	145	7.89
0.32	150	7.89

Note: The flow leaving through a restricted roof drain is based on flow vs. head information

McINTOSH PERRY

CO-23-3408 - 256 Centrum - SWM Calculations

5 of 10

Storage Requirements for Area B2

5-Year Storm Event

Tc (min)	I (mm/hr)	Runoff (L/s) B2	Allowable Outflow (L/s)	Runoff to be Stored (L/s)	Storage Required (m ³)
10	104.2	33.80	5.40	28.40	17.04
20	70.3	22.79	5.40	17.39	20.87
30	53.9	17.49	5.40	12.09	21.77
40	44.2	14.33	5.40	8.93	21.44
50	37.7	12.21	5.40	6.81	20.44
60	32.9	10.69	5.40	5.29	19.03
70	29.4	9.53	5.40	4.13	17.34
80	26.6	8.62	5.40	3.22	15.44
90	24.3	7.88	5.40	2.48	13.38
100	22.4	7.27	5.40	1.87	11.21
110	20.8	6.75	5.40	1.35	8.94

Maximum Storage Required 5-year = 22 m³

100-Year Storm Event

Tc (min)	I (mm/hr)	Runoff (L/s) B2	Allowable Outflow (L/s)	Runoff to be Stored (L/s)	Storage Required (m ³)
10	178.6	64.92	5.68	59.24	35.54
20	120.0	43.61	5.68	37.93	45.51
30	91.9	33.40	5.68	27.72	49.90
40	75.1	27.32	5.68	21.64	51.94
50	64.0	23.25	5.68	17.57	52.71
60	55.9	20.32	5.68	14.64	52.71
70	49.8	18.10	5.68	12.42	52.17
80	45.0	16.36	5.68	10.68	51.25
90	41.1	14.95	5.68	9.27	50.04
100	37.9	13.78	5.68	8.10	48.60
110	35.2	12.80	5.68	7.12	46.98
120	32.9	11.96	5.68	6.28	45.22
130	30.9	11.23	5.68	5.55	43.32
140	29.2	10.60	5.68	4.92	41.32
150	27.6	10.04	5.68	4.36	39.23
160	26.2	9.54	5.68	3.86	37.06
170	25.0	9.09	5.68	3.41	34.82

Maximum Storage Required 100-year = 53 m³

McINTOSH PERRY

Roof Storage			
Location	Area*	Depth	Volume (m ³)
Roof	904.68	0.025	22.62

Storage Available (m ³) =	22.62
Storage Required (m ³) =	21.77

100-Year Storm Event Storage Summary

Roof Storage			
Location	Area*	Depth	Volume (m ³)
Roof	904.68	0.065	58.80

Storage Available (m ³) =	58.80
Storage Required (m ³) =	52.71

* Area is 75% of the total roof area

McINTOSH PERRY

Roof Drain Flow B2

Roof Drains Summary		
Type of Control Device	Watts Drainage - Accutrol Weir	
Number of Roof Drains	18	
	5-Year	100-Year
Rooftop Storage (m ³)	22.62	58.80
Storage Depth (m)	0.025	0.065
Flow (Per Roof Drain) (L/s)	0.30	0.32
Total Flow (L/s)	5.40	5.68

Flow Rate Vs. Build-Up (One Weir-Fully Closed)	
Depth (mm)	Flow (L/s)
15	0.18
20	0.24
25	0.30
30	0.32
35	0.32
40	0.32
45	0.32
50	0.32
55	0.32

* Roof Drain model to be Accutrol Weirs, See attached sheets
 * Roof Drain Flow information taken from Watts Drainage website

CALCULATING ROOF FLOW EXAMPLES

1 roof drain during a 5 year storm
 elevation of water = 15mm
 Flow leaving 1 roof drain = (1 x 0.18 L/s) = 0.18 L/s

1 roof drain during a 100 year storm
 elevation of water = 50mm
 Flow leaving 1 roof drain = (1 x 0.32 L/s) = 0.32 L/s

4 roof drains during a 5 year storm
 elevation of water = 15mm
 Flow leaving 4 roof drains = (4 x 0.18L/s) = 0.72 L/s

4 roof drains during a 100 year storm
 elevation of water = 50mm
 Flow leaving 4 roof drains = (4 x 0.32 L/s) = 1.28 L/s

Roof Drain Flow		
Flow (l/s)	Storage Depth (mm)	Drains Flow (l/s)
0.18	15	3.24
0.24	20	4.32
0.30	25	5.40
0.32	30	5.68
0.32	35	5.68
0.32	40	5.68
0.32	45	5.68
0.32	50	5.68
0.32	55	5.68
0.32	60	5.68
0.32	65	5.68
0.32	70	5.68
0.32	75	5.68
0.32	80	5.68
0.32	85	5.68
0.32	90	5.68
0.32	95	5.68
0.32	100	5.68
0.32	105	5.68
0.32	110	5.68
0.32	115	5.68
0.32	120	5.68
0.32	125	5.68
0.32	130	5.68
0.32	135	5.68
0.32	140	5.68
0.32	145	5.68
0.32	150	5.68

Note: The flow leaving through a restricted roof drain is based on flow vs. head information

McINTOSH PERRY

CO-23-3408 - 256 Centrum - SWM Calculations

8 of 10

Storage Requirements for Area B3

5-Year Storm Event

Tc (min)	I (mm/hr)	Runoff (L/s) B3	Allowable Outflow (L/s)	Runoff to be Stored (L/s)	Storage Required (m ³)
10	104.2	39.48	7.93	31.55	18.93
20	70.3	26.62	7.93	18.69	22.42
30	53.9	20.43	7.93	12.50	22.50
40	44.2	16.74	7.93	8.81	21.15
50	37.7	14.27	7.93	6.34	19.01

Maximum Storage Required 5-year = 23 m³

100-Year Storm Event

Tc (min)	I (mm/hr)	Runoff (L/s) B3	Allowable Outflow (L/s)	Runoff to be Stored (L/s)	Storage Required (m ³)
10	178.6	153.50	15.22	138.28	82.97
20	120.0	103.12	15.22	87.90	105.47
30	91.9	78.97	15.22	63.75	114.76
40	75.1	64.60	15.22	49.38	118.51
50	64.0	54.98	15.22	39.76	119.27
60	55.9	48.05	15.22	32.83	118.19
70	49.8	42.80	15.22	27.58	115.84
80	45.0	38.68	15.22	23.46	112.59
90	41.1	35.34	15.22	20.12	108.65
100	37.9	32.58	15.22	17.36	104.18

Maximum Storage Required 100-year = 119 m³

5-Year Storm Event Storage Summary

Storage Available (m ³) = 119.3
Storage Required (m ³) = 22.5

100-Year Storm Event Storage Summary

Storage Available (m ³) = 119.3
Storage Required (m ³) = 119.3

* Available Storage Provided By Gstern

McINTOSH PERRY

Storage Requirements for Area B5

5-Year Storm Event

Tc (min)	I (mm/hr)	Runoff (L/s) B5	Allowable Outflow (L/s)	Runoff to be Stored (L/s)	Storage Required (m ³)
10	104.2	39.48	8.52	30.96	18.58
20	70.3	26.64	8.52	18.12	21.74
30	53.9	20.42	8.52	11.90	21.43
40	44.2	16.75	8.52	8.23	19.75
50	37.7	14.28	8.52	5.77	17.30

Maximum Storage Required 5-year =	22 m ³
-----------------------------------	-------------------

100-Year Storm Event

Tc (min)	I (mm/hr)	Runoff (L/s) B5	Allowable Outflow (L/s)	Runoff to be Stored (L/s)	Storage Required (m ³)
10	178.6	76.20	8.52	67.68	40.61
20	120.0	51.20	8.52	42.68	51.22
30	91.9	39.21	8.52	30.69	55.24
40	75.1	32.04	8.52	23.52	56.46
50	64.0	27.31	8.52	18.79	56.36
60	55.9	23.85	8.52	15.33	55.19
70	49.8	21.25	8.52	12.73	53.46
80	45.0	19.20	8.52	10.68	51.27
90	41.1	17.54	8.52	9.02	48.69
100	37.9	16.17	8.52	7.65	45.91

Maximum Storage Required 100-year =	56 m ³
-------------------------------------	-------------------

5-Year Storm Event Storage Summary

Roof Storage			
Location	Area*	Depth	Volume (m ³)
Roof	1013.25	0.030	30.40

Storage Available (m ³) =	30.40
Storage Required (m ³) =	21.74

100-Year Storm Event Storage Summary

Roof Storage			
Location	Area*	Depth	Volume (m ³)
Roof	1013.25	0.065	65.86

Storage Available (m ³) =	65.86
Storage Required (m ³) =	56.46

* Area is 75% of the total roof area

McINTOSH PERRY

Roof Drain Flow B5

Roof Drains Summary		
Type of Control Device	Watts Drainage - Accutrol Weir	
Number of Roof Drains	27	
	5-Year	100-Year
Rooftop Storage (m ³)	30.40	65.86
Storage Depth (m)	0.030	0.065
Flow (Per Roof Drain) (L/s)	0.32	0.32
Total Flow (L/s)	8.52	8.52

Flow Rate Vs. Build-Up (One Weir-Fully Closed)	
Depth (mm)	Flow (L/s)
15	0.18
20	0.24
25	0.30
30	0.32
35	0.32
40	0.32
45	0.32
50	0.32
55	0.32

* Roof Drain model to be Accutrol Weirs, See attached sheets
 * Roof Drain Flow information taken from Watts Drainage website

CALCULATING ROOF FLOW EXAMPLES

1 roof drain during a 5 year storm
 elevation of water = 15mm
 Flow leaving 1 roof drain = (1 x 0.18 L/s) = 0.18 L/s

1 roof drain during a 100 year storm
 elevation of water = 50mm
 Flow leaving 1 roof drain = (1 x 0.32 L/s) = 0.32 L/s

4 roof drains during a 5 year storm
 elevation of water = 15mm
 Flow leaving 4 roof drains = (4 x 0.18L/s) = 0.72 L/s

4 roof drains during a 100 year storm
 elevation of water = 50mm
 Flow leaving 4 roof drains = (4 x 0.32 L/s) = 1.28 L/s

Roof Drain Flow		
Flow (l/s)	Storage Depth (mm)	Drains Flow (l/s)
0.18	15	4.86
0.24	20	6.48
0.30	25	8.10
0.32	30	8.52
0.32	35	8.52
0.32	40	8.52
0.32	45	8.52
0.32	50	8.52
0.32	55	8.52
0.32	60	8.52
0.32	65	8.52
0.32	70	8.52
0.32	75	8.52
0.32	80	8.52
0.32	85	8.52
0.32	90	8.52
0.32	95	8.52
0.32	100	8.52
0.32	105	8.52
0.32	110	8.52
0.32	115	8.52
0.32	120	8.52
0.32	125	8.52
0.32	130	8.52
0.32	135	8.52
0.32	140	8.52
0.32	145	8.52
0.32	150	8.52

Note: The flow leaving through a restricted roof drain is based on flow vs. head information

STORM SEWER DESIGN SHEET

PROJECT: COO-23-3408
 LOCATION: 265 Centrum
 CLIENT: Bayview Group



LOCATION				CONTRIBUTING AREA (ha)				RATIONAL DESIGN FLOW										SEWER DATA													
1	2	3	4	5	6	7	8	9	10	11	12	13	14	15	16	17	18	19	20	21	22			23	24	25	26	27	28		
STREET	AREA ID	FROM MH	TO MH	C-VALUE	AREA	INDIV AC	CUMUL AC	INLET (min)	TIME IN PIPE	TOTAL (min)	i (5) (mm/hr)	i (10) (mm/hr)	i (100) (mm/hr)	5yr PEAK FLOW (L/s)	10yr PEAK FLOW (L/s)	100yr PEAK FLOW (L/s)	FIXED FLOW (L/s)	DESIGN FLOW (L/s)	CAPACITY (L/s)	LENGTH (m)	PIPE SIZE (mm)			SLOPE (%)	VELOCITY (m/s)	AVAIL CAP (5yr)					
																					DIA	W	H			(L/s)	(%)				
Brisebois Cres.	B1	BLDG	EX STM. Sewer	0.72	0.14	0.10																									
	B2			0.72	0.16	0.12																									
	B3			0.74	0.37	0.28	0.49	10.00	0.13	10.13	104.19	122.14	178.56	141.96	166.41	243.28		141.96	182.91	12.92	375			1.00	1.604	40.95	22.39%				
Centrum Blvd	B5	BLDG	EX STM. Sewer	0.65	0.21	0.14	0.14	10.00	0.14	10.14	104.19	122.14	178.56	39.48	46.28	67.65		39.48	62.04	10.44	250			1.00	1.224	22.56	36.37%				
Definitions: Q = 2.78QA, where: Q = Peak Flow in Litres per Second (L/s) A = Area in Hectares (ha) i = Rainfall intensity in millimeters per hour (mm/hr) [i = 998.071 / (TC+6.053)^0.814] 5 YEAR [i = 1174.184 / (TC+6.014)^0.816] 10 YEAR [i = 1735.688 / (TC+6.014)^0.820] 100 YEAR				Notes: 1. Mannings coefficient (n) = 0.013				Designed: R.R.R. Checked: A.M. Project No.: COO-23-3408				No. Revision Date 1.				Date: Sheet No: 1 of 1															



Adjustable Accutrol Weir

Tag: _____

Adjustable Flow Control for Roof Drains

ADJUSTABLE ACCUTROL (for Large Sump Roof Drains only)

For more flexibility in controlling flow with heads deeper than 2", Watts Drainage offers the Adjustable Accutrol. The Adjustable Accutrol Weir is designed with a single parabolic opening that can be covered to restrict flow above 2" of head to less than 5 gpm per inch, up to 6" of head. To adjust the flow rate for depths over 2" of head, set the slot in the adjustable upper cone according to the flow rate required. Refer to Table 1 below.
 Note: Flow rates are directly proportional to the amount of weir opening that is exposed.

EXAMPLE:

For example, if the adjustable upper cone is set to cover 1/2 of the weir opening, flow rates above 2" of head will be restricted to 2-1/2 gpm per inch of head.

Therefore, at 3" of head, the flow rate through the Accutrol Weir that has 1/2 the slot exposed will be:
 [5 gpm (per inch of head) x 2 inches of head] + 2-1/2 gpm (for the third inch of head) = 12-1/2 gpm.

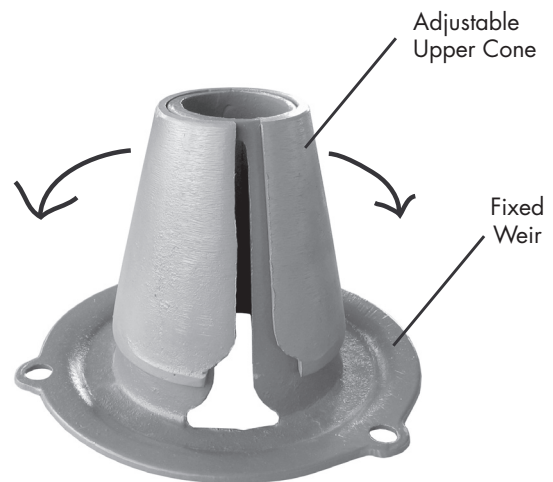
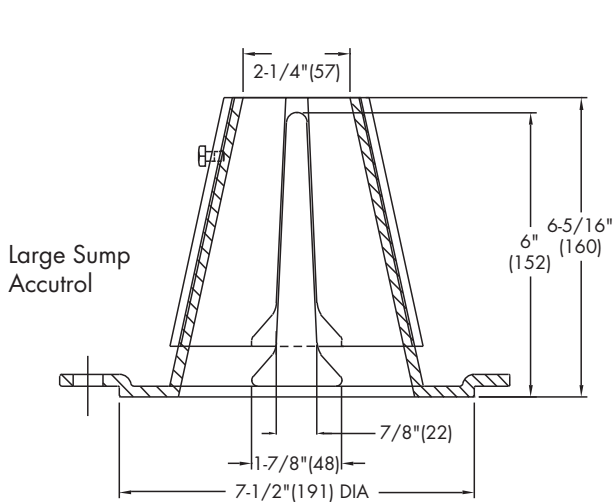

1/2 Weir Opening Exposed Shown Above

TABLE 1. Adjustable Accutrol Flow Rate Settings

Weir Opening Exposed	1"	2"	3"	4"	5"	6"
	Flow Rate (gallons per minute)					
Fully Exposed	5	10	15	20	25	30
3/4	5	10	13.75	17.5	21.25	25
1/2	5	10	12.5	15	17.5	20
1/4	5	10	11.25	12.5	13.75	15
Closed	5	5	5	5	5	5

Job Name _____
 Job Location _____
 Engineer _____

Contractor _____
 Contractor's P.O. No. _____
 Representative _____

Watts product specifications in U.S. customary units and metric are approximate and are provided for reference only. For precise measurements, please contact Watts Technical Service. Watts reserves the right to change or modify product design, construction, specifications, or materials without prior notice and without incurring any obligation to make such changes and modifications on Watts products previously or subsequently sold.

USA: Tel: (800) 338-2581 • Fax: (828) 248-3929 • Watts.com
 Canada: Tel: (905) 332-4090 • Fax: (905) 332-7068 • Watts.ca
 Latin America: Tel: (52) 81-1001-8600 • Fax: (52) 81-8000-7091 • Watts.com



APPENDIX H
CITY OF OTTAWA DESIGN CHECKLIST

City of Ottawa

4. Development Servicing Study Checklist

The following section describes the checklist of the required content of servicing studies. It is expected that the proponent will address each one of the following items for the study to be deemed complete and ready for review by City of Ottawa Infrastructure Approvals staff.

The level of required detail in the Servicing Study will increase depending on the type of application. For example, for Official Plan amendments and re-zoning applications, the main issues will be to determine the capacity requirements for the proposed change in land use and confirm this against the existing capacity constraint, and to define the solutions, phasing of works and the financing of works to address the capacity constraint. For subdivisions and site plans, the above will be required with additional detailed information supporting the servicing within the development boundary.

4.1 General Content

Criteria	Location (if applicable)
<input type="checkbox"/> Executive Summary (for larger reports only).	N/A
<input type="checkbox"/> Date and revision number of the report.	On Cover
<input type="checkbox"/> Location map and plan showing municipal address, boundary, and layout of proposed development.	Appendix A
<input type="checkbox"/> Plan showing the site and location of all existing services.	Site Servicing Plan (C102)
<input type="checkbox"/> Development statistics, land use, density, adherence to zoning and official plan, and reference to applicable subwatershed and watershed plans that provide context to which individual developments must adhere.	1.1 Purpose 1.2 Site Description 6.0 Stormwater Management
<input type="checkbox"/> Summary of pre-consultation meetings with City and other approval agencies.	Appendix B
<input type="checkbox"/> Reference and confirm conformance to higher level studies and reports (Master Servicing Studies, Environmental Assessments, Community Design Plans), or in the case where it is not in conformance, the proponent must provide justification and develop a defensible design criteria.	1.1 Purpose 1.2 Site Description 6.0 Stormwater Management
<input type="checkbox"/> Statement of objectives and servicing criteria.	3.0 Pre-Consultation Summary

<input type="checkbox"/> Identification of existing and proposed infrastructure available in the immediate area.	N/A
<input type="checkbox"/> Identification of Environmentally Significant Areas, watercourses and Municipal Drains potentially impacted by the proposed development (Reference can be made to the Natural Heritage Studies, if available).	Ste Grading Plan (C101)
<input type="checkbox"/> Concept level master grading plan to confirm existing and proposed grades in the development. This is required to confirm the feasibility of proposed stormwater management and drainage, soil removal and fill constraints, and potential impacts to neighbouring properties. This is also required to confirm that the proposed grading will not impede existing major system flow paths.	Ste Grading Plan (C101)
<input type="checkbox"/> Identification of potential impacts of proposed piped services on private services (such as wells and septic fields on adjacent lands) and mitigation required to address potential impacts.	N/A
<input type="checkbox"/> Proposed phasing of the development, if applicable.	N/A
<input type="checkbox"/> Reference to geotechnical studies and recommendations concerning servicing.	Section 2.0 Background Studies, Standards and References
<input type="checkbox"/> All preliminary and formal site plan submissions should have the following information: <ul style="list-style-type: none"> ○ Metric scale ○ North arrow (including construction North) ○ Key plan ○ Name and contact information of applicant and property owner ○ Property limits including bearings and dimensions ○ Existing and proposed structures and parking areas ○ Easements, road widening and rights-of-way ○ Adjacent street names 	Ste Grading Plan (C101)

4.2 Development Servicing Report: Water

Criteria	Location (if applicable)
<input type="checkbox"/> Confirm consistency with Master Servicing Study, if available	N/A
<input type="checkbox"/> Availability of public infrastructure to service proposed development	N/A
<input type="checkbox"/> Identification of system constraints	N/A
<input type="checkbox"/> Identify boundary conditions	Appendix C
<input type="checkbox"/> Confirmation of adequate domestic supply and pressure	N/A
<input type="checkbox"/> Confirmation of adequate fire flow protection and confirmation that fire flow is calculated as per the Fire Underwriter's Survey. Output should show available fire flow at locations throughout the development.	Appendix C
<input type="checkbox"/> Provide a check of high pressures. If pressure is found to be high, an assessment is required to confirm the application of pressure reducing valves.	N/A
<input type="checkbox"/> Definition of phasing constraints. Hydraulic modeling is required to confirm servicing for all defined phases of the project including the ultimate design	N/A
<input type="checkbox"/> Address reliability requirements such as appropriate location of shut-off valves	N/A
<input type="checkbox"/> Check on the necessity of a pressure zone boundary modification.	N/A
<input type="checkbox"/> Reference to water supply analysis to show that major infrastructure is capable of delivering sufficient water for the proposed land use. This includes data that shows that the expected demands under average day, peak hour and fire flow conditions provide water within the required pressure range	Appendix C, Section 4.2

<input type="checkbox"/> Description of the proposed water distribution network, including locations of proposed connections to the existing system, provisions for necessary looping, and appurtenances (valves, pressure reducing valves, valve chambers, and fire hydrants) including special metering provisions.	Site Servicing Plan (C101)
<input type="checkbox"/> Description of off-site required feeder mains, booster pumping stations, and other water infrastructure that will be ultimately required to service proposed development, including financing, interim facilities, and timing of implementation.	N/A
<input type="checkbox"/> Confirmation that water demands are calculated based on the City of Ottawa Design Guidelines.	Appendix C
<input type="checkbox"/> Provision of a model schematic showing the boundary conditions locations, streets, parcels, and building locations for reference.	N/A

4.3 Development Servicing Report: Wastewater

Criteria	Location (if applicable)
<input type="checkbox"/> Summary of proposed design criteria (Note: Wet-weather flow criteria should not deviate from the City of Ottawa Sewer Design Guidelines. Monitored flow data from relatively new infrastructure cannot be used to justify capacity requirements for proposed infrastructure).	N/A
<input type="checkbox"/> Confirm consistency with Master Servicing Study and/or justifications for deviations.	N/A
<input type="checkbox"/> Consideration of local conditions that may contribute to extraneous flows that are higher than the recommended flows in the guidelines. This includes groundwater and soil conditions, and age and condition of sewers.	N/A
<input type="checkbox"/> Description of existing sanitary sewer available for discharge of wastewater from proposed development.	Section 5.2 Proposed Sanitary Sewer

<input type="checkbox"/> Verify available capacity in downstream sanitary sewer and/or identification of upgrades necessary to service the proposed development. (Reference can be made to previously completed Master Servicing Study if applicable)	Section 5.3 Proposed Sanitary Design
<input type="checkbox"/> Calculations related to dry-weather and wet-weather flow rates from the development in standard MOE sanitary sewer design table (Appendix 'C') format.	N/A
<input type="checkbox"/> Description of proposed sewer network including sewers, pumping stations, and forcemains.	Section 5.2 Proposed Sanitary Sewer
<input type="checkbox"/> Discussion of previously identified environmental constraints and impact on servicing (environmental constraints are related to limitations imposed on the development in order to preserve the physical condition of watercourses, vegetation, soil cover, as well as protecting against water quantity and quality).	N/A
<input type="checkbox"/> Pumping stations: impacts of proposed development on existing pumping stations or requirements for new pumping station to service development.	N/A
<input type="checkbox"/> Forcemain capacity in terms of operational redundancy, surge pressure and maximum flow velocity.	N/A
<input type="checkbox"/> Identification and implementation of the emergency overflow from sanitary pumping stations in relation to the hydraulic grade line to protect against basement flooding.	N/A
<input type="checkbox"/> Special considerations such as contamination, corrosive environment etc.	N/A

4.4 Development Servicing Report: Stormwater Checklist

Criteria	Location (if applicable)
<input type="checkbox"/> Description of drainage outlets and downstream constraints including legality of outlets (i.e. municipal drain, right-of-way, watercourse, or private property)	Section 6.0 Stormwater Sewer Design & Section 7.0 Proposed Stormwater Management
<input type="checkbox"/> Analysis of available capacity in existing public infrastructure.	N/A
<input type="checkbox"/> A drawing showing the subject lands, its surroundings, the receiving watercourse, existing drainage patterns, and proposed drainage pattern.	Pre & Post-Development Plans
<input type="checkbox"/> Water quantity control objective (e.g. controlling post-development peak flows to pre-development level for storm events ranging from the 2 or 5-year event (dependent on the receiving sewer design) to 100-year return period); if other objectives are being applied, a rationale must be included with reference to hydrologic analyses of the potentially affected subwatersheds, taking into account long-term cumulative effects.	Section 6.0 Stormwater Sewer Design & Section 7.0 Proposed Stormwater Management
<input type="checkbox"/> Water Quality control objective (basic, normal or enhanced level of protection based on the sensitivities of the receiving watercourse) and storage requirements.	Section 6.0 Stormwater Sewer Design & Section 7.0 Proposed Stormwater Management
<input type="checkbox"/> Description of the stormwater management concept with facility locations and descriptions with references and supporting information.	Section 6.0 Stormwater Sewer Design & Section 7.0 Proposed Stormwater Management
<input type="checkbox"/> Set-back from private sewage disposal systems.	N/A
<input type="checkbox"/> Watercourse and hazard lands setbacks.	N/A
<input type="checkbox"/> Record of pre-consultation with the Ontario Ministry of Environment and the Conservation Authority that has jurisdiction on the affected watershed.	N/A
<input type="checkbox"/> Confirm consistency with sub-watershed and Master Servicing Study, if applicable study exists.	N/A
<input type="checkbox"/> Storage requirements (complete with calculations) and conveyance capacity for minor events (1:5-year return period) and major events (1:100-year return period).	Appendix G

<input type="checkbox"/> Identification of watercourses within the proposed development and how watercourses will be protected, or, if necessary, altered by the proposed development with applicable approvals.	Site Grading Plan
<input type="checkbox"/> Calculate pre-and post development peak flow rates including a description of existing site conditions and proposed impervious areas and drainage catchments in comparison to existing conditions.	Section 7.0 Proposed Stormwater Management Appendix G
<input type="checkbox"/> Any proposed diversion of drainage catchment areas from one outlet to another.	Section 6.0 Stormwater Sewer Design & Section 7.0 Proposed Stormwater Management
<input type="checkbox"/> Proposed minor and major systems including locations and sizes of stormwater trunk sewers, and stormwater management facilities.	Section 6.0 Stormwater Sewer Design & Section 7.0 Proposed Stormwater Management
<input type="checkbox"/> If quantity control is not proposed, demonstration that downstream system has adequate capacity for the post-development flows up to and including the 100-year return period storm event.	N/A
<input type="checkbox"/> Identification of potential impacts to receiving watercourses	N/A
<input type="checkbox"/> Identification of municipal drains and related approval requirements.	N/A
<input type="checkbox"/> Descriptions of how the conveyance and storage capacity will be achieved for the development.	Section 6.0 Stormwater Sewer Design & Section 7.0 Proposed Stormwater Management
<input type="checkbox"/> 100-year flood levels and major flow routing to protect proposed development from flooding for establishing minimum building elevations (MBE) and overall grading.	Site Grading Plan (C101)
<input type="checkbox"/> Inclusion of hydraulic analysis including hydraulic grade line elevations.	N/A

<input type="checkbox"/> Description of approach to erosion and sediment control during construction for the protection of receiving watercourse or drainage corridors.	Section 8.0 Sediment & Erosion Control
<input type="checkbox"/> Identification of floodplains – proponent to obtain relevant floodplain information from the appropriate Conservation Authority. The proponent may be required to delineate floodplain elevations to the satisfaction of the Conservation Authority if such information is not available or if information does not match current conditions.	N/A
<input type="checkbox"/> Identification of fill constraints related to floodplain and geotechnical investigation.	N/A

4.5 Approval and Permit Requirements: Checklist

The Servicing Study shall provide a list of applicable permits and regulatory approvals necessary for the proposed development as well as the relevant issues affecting each approval. The approval and permitting shall include but not be limited to the following:

Criteria	Location (if applicable)
<input type="checkbox"/> Conservation Authority as the designated approval agency for modification of floodplain, potential impact on fish habitat, proposed works in or adjacent to a watercourse, cut/fill permits and Approval under Lakes and Rivers Improvement Act. The Conservation Authority is not the approval authority for the Lakes and Rivers Improvement Act. Where there are Conservation Authority regulations in place, approval under the Lakes and Rivers Improvement Act is not required, except in cases of dams as defined in the Act.	N/A
<input type="checkbox"/> Application for Certificate of Approval (CofA) under the Ontario Water Resources Act.	N/A
<input type="checkbox"/> Changes to Municipal Drains.	N/A
<input type="checkbox"/> Other permits (National Capital Commission, Parks Canada, Public Works and Government Services Canada, Ministry of Transportation etc.)	N/A

4.6 Conclusion Checklist

Criteria	Location (if applicable)
<input type="checkbox"/> Clearly stated conclusions and recommendations	Section 9.0 Summary Section 10.0 Recommendations
<input type="checkbox"/> Comments received from review agencies including the City of Ottawa and information on how the comments were addressed. Final sign-off from the responsible reviewing agency.	All are stamped
<input type="checkbox"/> All draft and final reports shall be signed and stamped by a professional Engineer registered in Ontario	All are stamped