

- LEGEND:**
- EXISTING PROPERTY LINE TO REMAIN
  - PROPOSED EASEMENT
  - PROPOSED TERRACING (0.1 MIN.)
  - PROPOSED DOOR ENTRANCE/EXIT
  - PROPOSED ELEVATION
  - +50.00 PROPOSED HIGH POINT ELEVATION
  - +50.00SW PROPOSED SWALE ELEVATION
  - +50.00EX MATCH INTO EXISTING ELEVATION
  - 70.19 EXISTING ELEVATION
  - PROPOSED OVERLAND MAJOR FLOW ROUTE
  - PROPOSED SILT FENCE AS PER OPSD 219.110
  - PROPOSED 100mm PERFORATED SUBDRAIN
  - PROPOSED STORM SEWER
  - PROPOSED SANITARY SEWER
  - PROPOSED WATERMAIN
  - EXISTING SANITARY SEWER
  - EXISTING WATERMAIN
  - PROPOSED CATCH BASIN/MANHOLE/CATCH BASIN
  - PROPOSED CURB STOP
  - PROPOSED PIPE INSULATION
  - PROPOSED 100 YEAR HIGH WATER LEVEL
  - STORM WATERSHED EXTENT
  - WATERSHED NAME
  - RUNOFF COEFFICIENT
  - AREA IN HECTARES
  - PROPOSED GRASS AREA
  - PROPOSED CONCRETE FEATURES/SLAB
  - PROPOSED HEAVY DUTY ASPHALT
  - PROPOSED LIGHT DUTY ASPHALT
  - PROPOSED GRAVEL AREA
  - PROPOSED RIP RAP AS PER OPSD 810.010
  - PROPOSED WATER METER
  - PROPOSED ACCESS GATE
  - PROPOSED GROWING FIELD

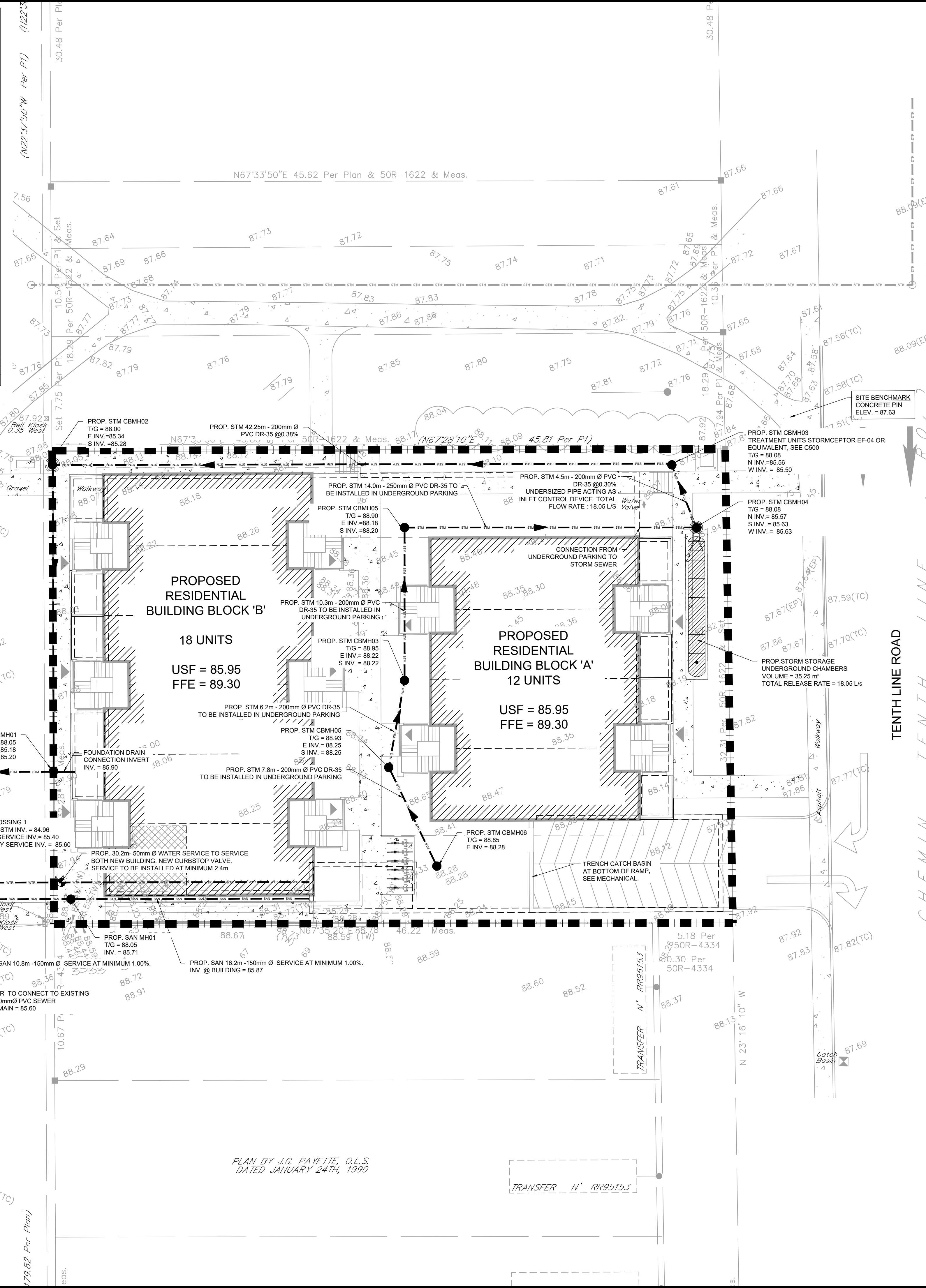
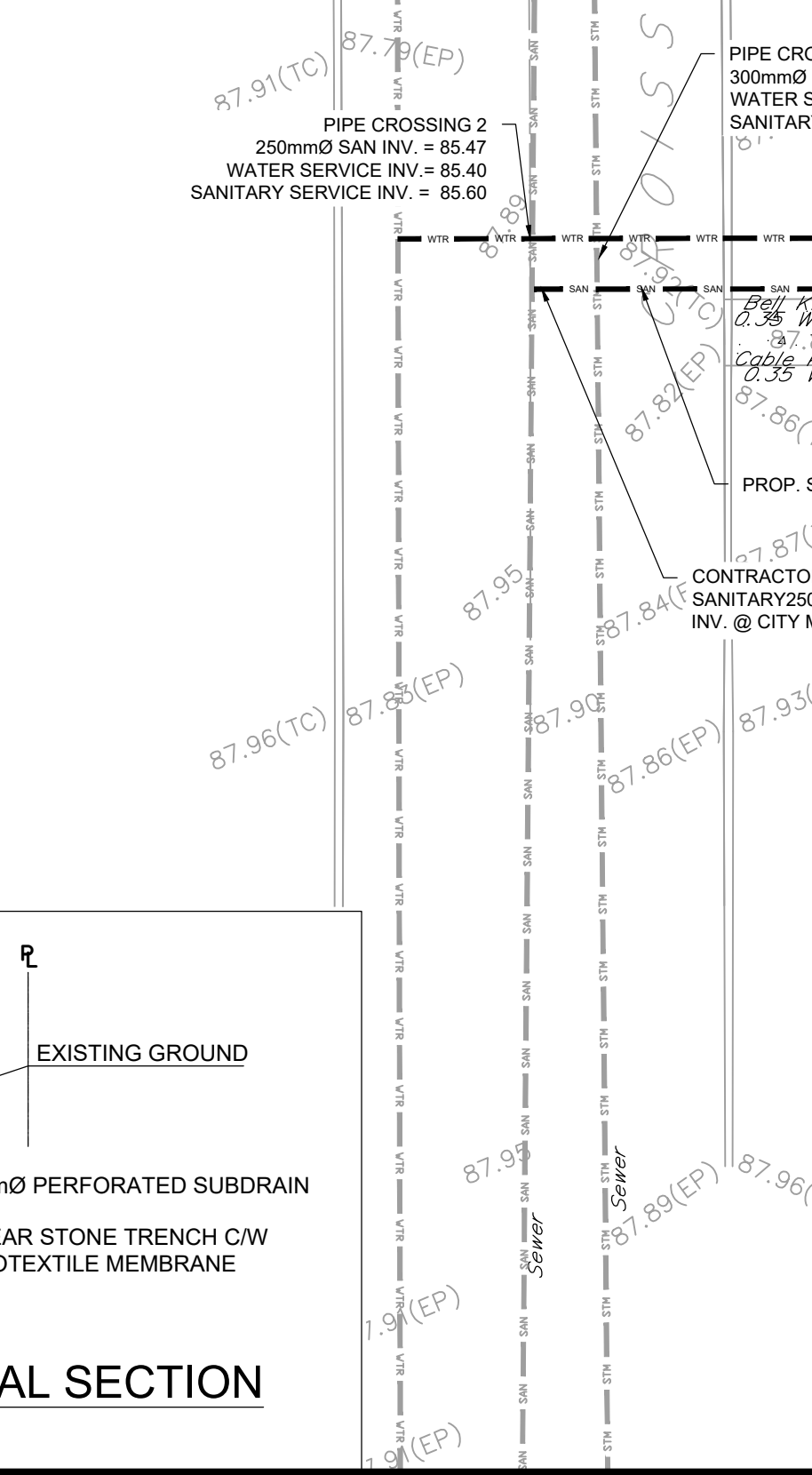
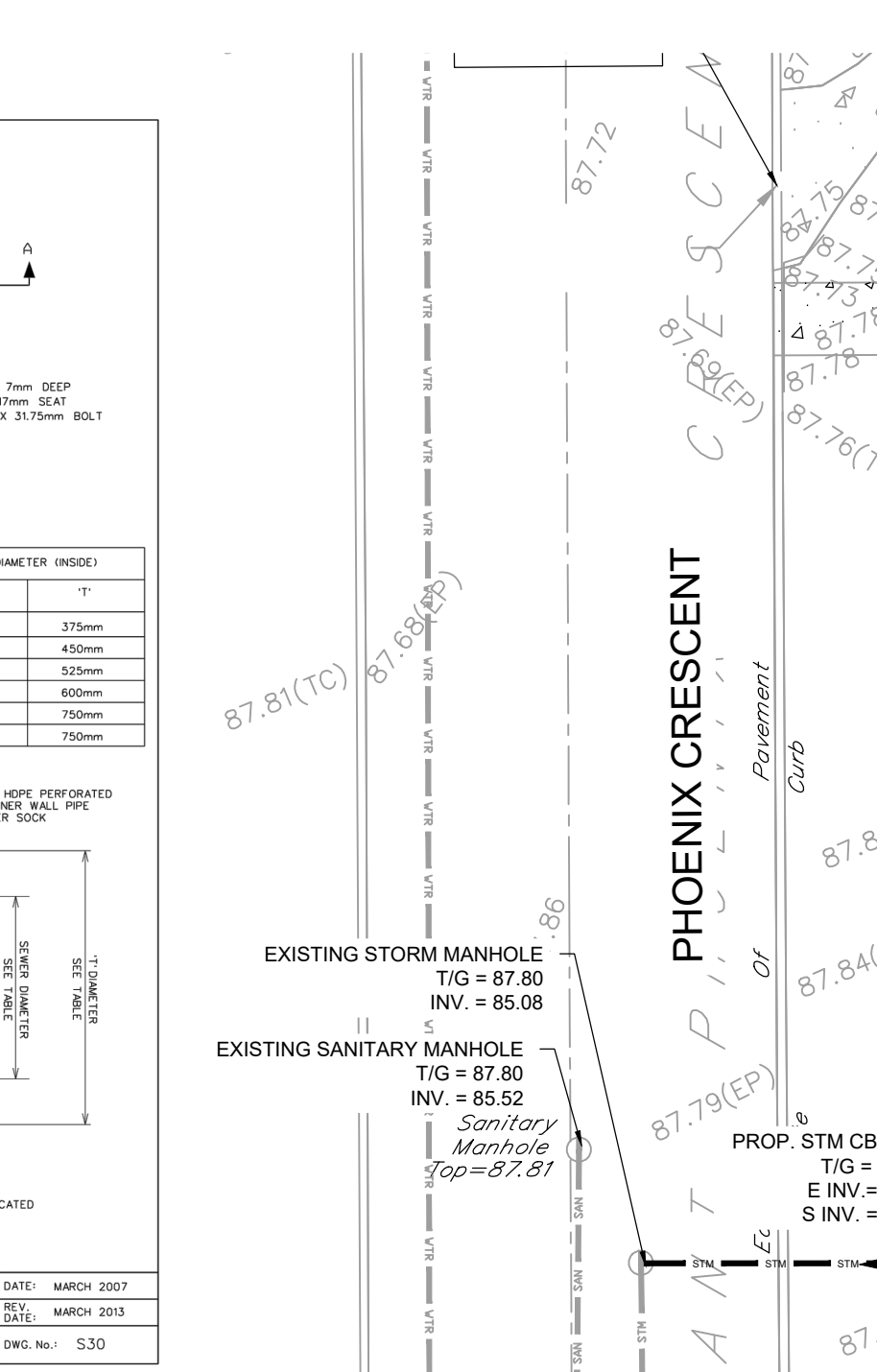
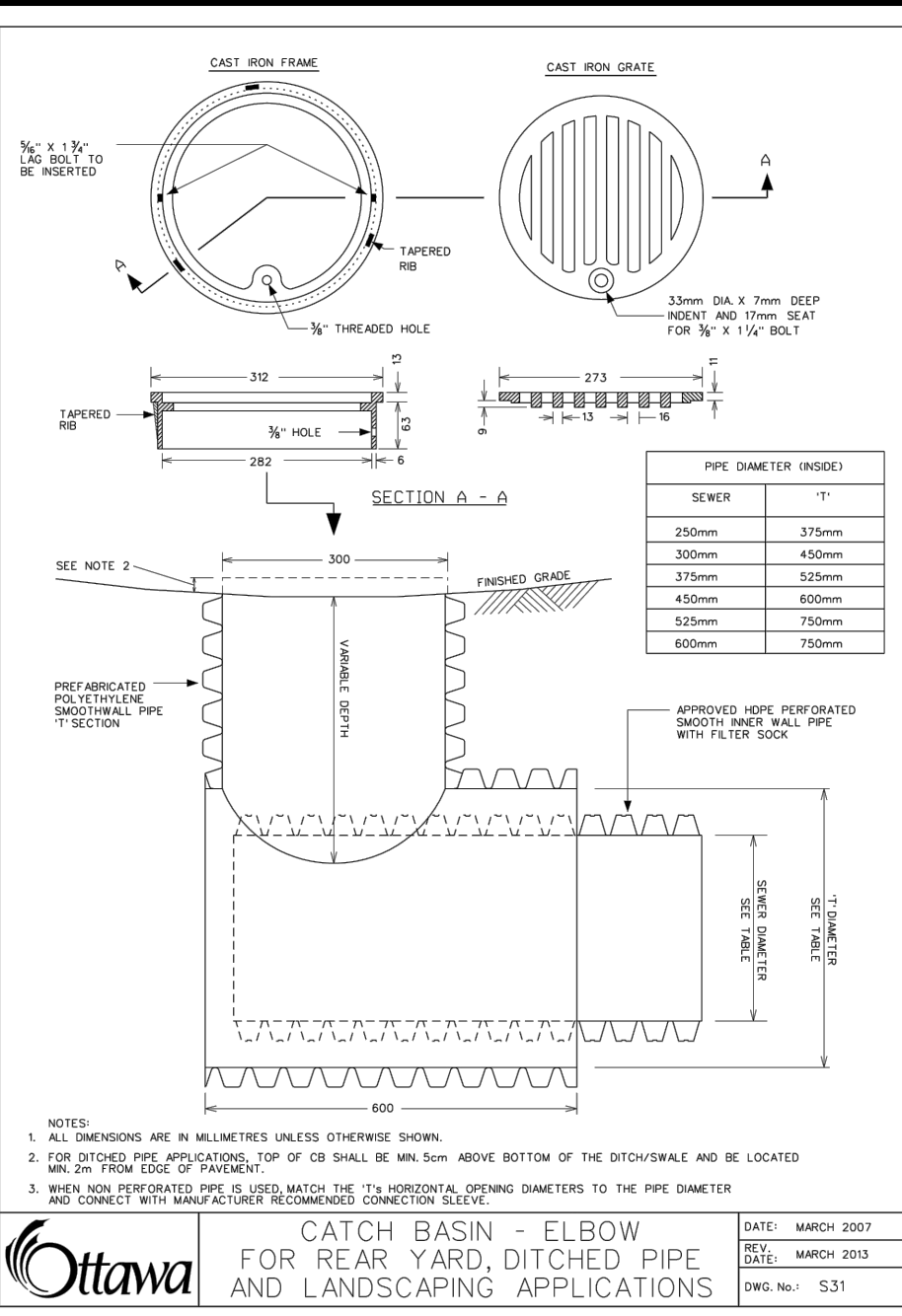

**ENGINEERING STAMP**

**BLANCHARD LETENDRE ENGINEERING**

**CLIENT: OLIGO DEVELOPMENT**

**PROJECT: NEW RESIDENTIAL DEVELOPMENT**

**DRAWING: SITE SERVICING PLAN**

**PAGE: C300**