

KEY PLAN - N.T.S.

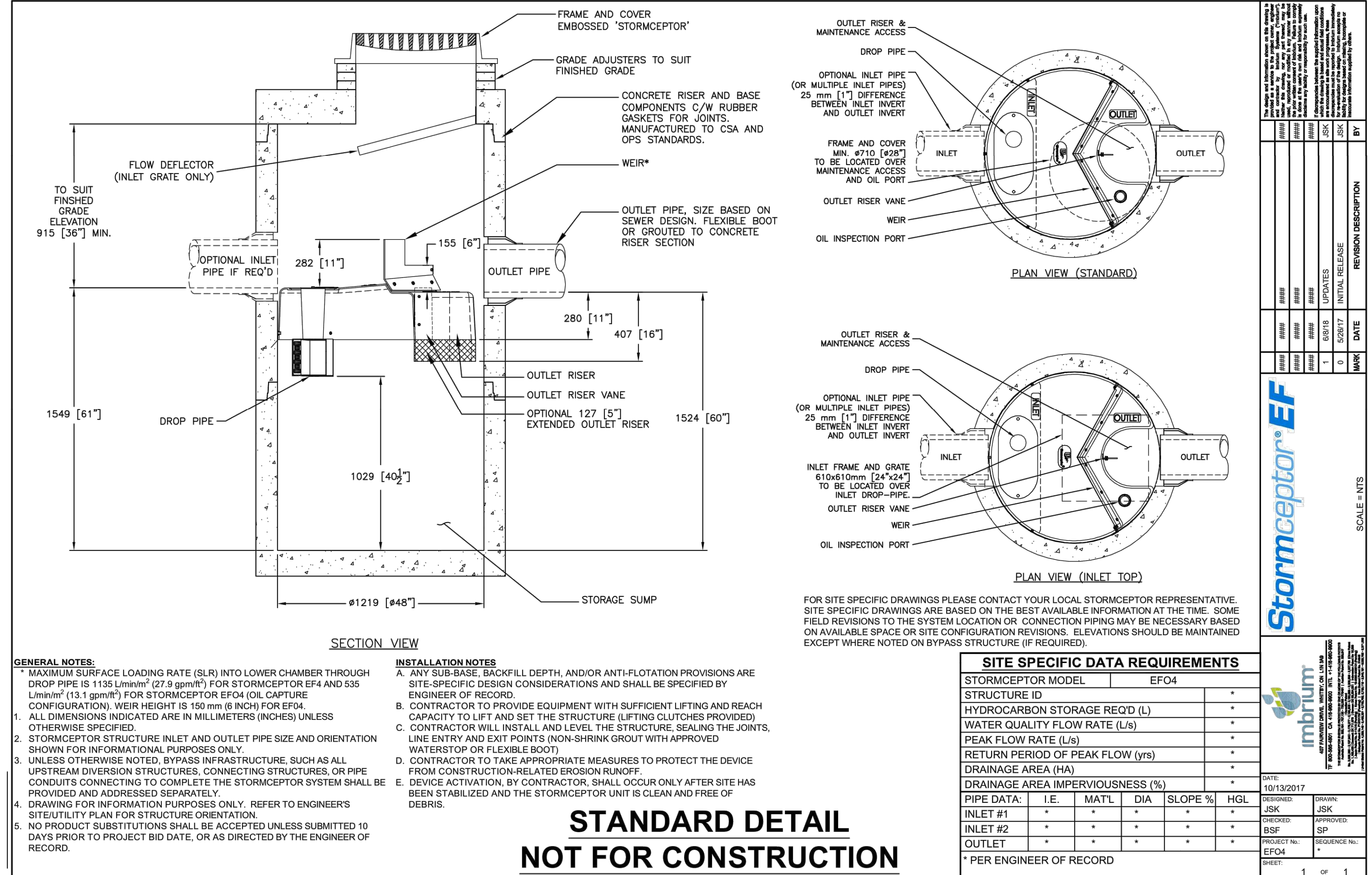

DISCLAIMER AND COPYRIGHT

CONTRACTOR MUST VERIFY ALL DIMENSIONS AND BE RESPONSIBLE FOR SAME. ANY DISCREPANCIES MUST BE REPORTED TO THE ENGINEER BEFORE COMMENCING WORK. DRAWINGS ARE NOT TO BE SCALED.

TATHAM ENGINEERING LIMITED CLAIMS COPYRIGHT TO THIS DRAWING WHICH MAY NOT BE USED FOR ANY PURPOSE OTHER THAN THAT PROVIDED IN THE CONTRACT BETWEEN THE OWNER/CLIENT AND THE ENGINEER WITHOUT THE EXPRESS CONSENT OF TATHAM ENGINEERING LIMITED.

LEGAL AND TOPOGRAPHIC SURVEY COMPLETED BY ARPENTAGE DUTRISAC SURVEYING INC.

BENCHMARK1: CONCRETE PIN LOCATED ON NORTH EAST CORNER OF THE SITE, ELEVATION: 87.63

BENCHMARK2: CONCRETE PIN LOCATED ON NORTH WEST CORNER OF THE SITE, ELEVATION: 87.72

No.	REVISION DESCRIPTION	DATE	ENGINEER STAMP
1.	ISSUED FOR SPA	DEC. 2022	
2.	AS PER ARCHITECT'S COMMENTS	DEC. 2022	
3.	RE-ISSUED FOR SPA	JUN. 2023	

BRIDOR DEVELOPMENTS
1592 TENTH LINE ROAD
CITY OF OTTAWA

DETAILS

TATHAM ENGINEERING

DESIGN: HY/GC FILE: 522677 DWG: **C500**

DRAWN: HY DATE: NOV 2022

CHECK: GC SCALE: 1:150

18576