

COPYRIGHT RESERVED  
 THE CONTRACTOR SHALL VERIFY AND BE RESPONSIBLE OF ALL DIMENSIONS. DO NOT SCALE THE DRAWING. ANY ERRORS OR OMISSIONS SHALL BE REPORTED TO BLANCHARD LETENDRE ENGINEERING LTD. WITHOUT DELAY. THE CONTRACTOR SHALL DESIGN AND DRAWINGS ARE THE PROPERTY OF BLANCHARD LETENDRE ENGINEERING LTD. REPRODUCTION OR USE FOR ANY PURPOSE OTHER THAN THAT AUTHORIZED BY BLANCHARD LETENDRE ENGINEERING LTD. IS STRICTLY PROHIBITED.

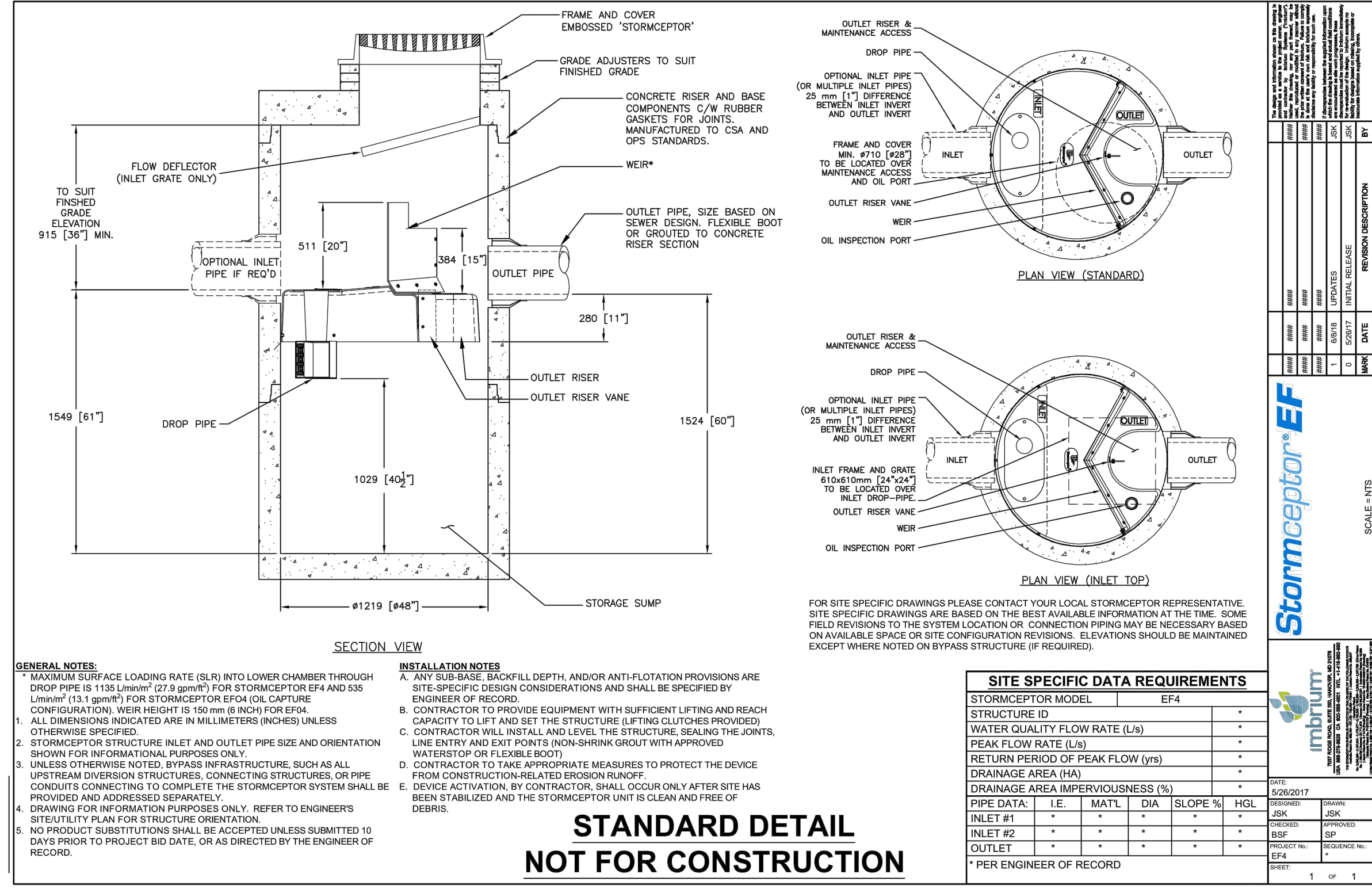
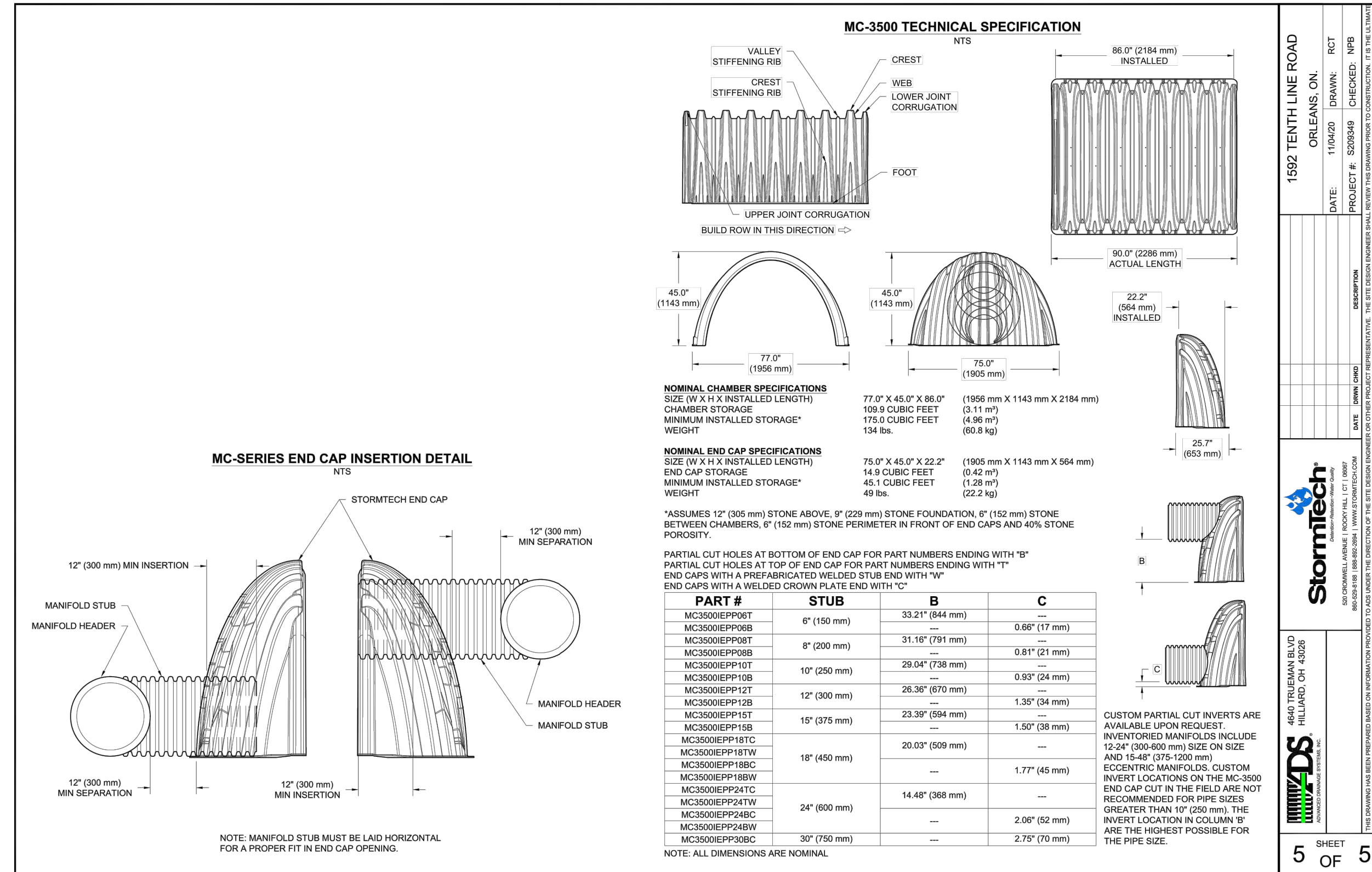

**ENGINEERING STAMP**

**CLIENT:**  
 OLIGO DEVELOPMENT  
 996-B ST. AUGUSTIN RD.  
 EMBRUN, ON

**PROJECT:**  
 NEW RESIDENTIAL DEVELOPMENT  
 1592 TENTH LINE RD.  
 ORLEANS, ON

**DRAWING:**  
 DETAILS - 2

**PAGE:**  
 C501

PAPER FORMAT: 24x36  
 DRAWN BY: BF + GB  
 CHECKED BY: GB  
 DATE: 01-2021  
 SCALE:  
 PROJECT NUMBER: 20-363