



**Servicing and Stormwater
Management Report Rev.02:
283 – 285 McLeod Street**

Stantec Project No. 160401782

City Project No. D01-01-21-0014
& D02-02-21-0084

May 29, 2023

Prepared for:

REZY Properties Inc.

Prepared by:

Stantec Consulting Ltd.
300-1331 Clyde Avenue
Ottawa ON K2C 3G4



Revision	Description	Author		Quality Check		Independent Review	
0	1 st Submission (Re-zoning application)	NN	2021-08-11	KS, ALG, TR	2021-08-12	KK	2021-08-13
1	2 nd Submission (Re-zoning application)	MW	2023-01-10	NC	2023-01-10	KK	2022-12-22
2	3 rd Submission (Re-zoning application)	MW	2023-05-18	NC	2023-05-29	KK DT	2023-05-11 (Servicing) 2023-05-11 (SWM)



SERVICING AND STORMWATER MANAGEMENT REPORT REV.02: 283 – 285 MCLEOD STREET

The conclusions in the Report titled Servicing and Stormwater Management Report Rev.02: 283 – 285 McLeod Street are Stantec’s professional opinion, as of the time of the Report, and concerning the scope described in the Report. The opinions in the document are based on conditions and information existing at the time the scope of work was conducted and do not take into account any subsequent changes. The Report relates solely to the specific project for which Stantec was retained and the stated purpose for which the Report was prepared. The Report is not to be used or relied on for any variation or extension of the project, or for any other project or purpose, and any unauthorized use or reliance is at the recipient’s own risk.

Stantec has assumed all information received from REZY Properties Inc. (the “Client and third parties in the preparation of the Report to be correct. While Stantec has exercised a customary level of judgment or due diligence in the use of such information, Stantec assumes no responsibility for the consequences of any error or omission contained therein.

This Report is intended solely for use by the Client in accordance with Stantec’s contract with the Client. While the Report may be provided to applicable authorities having jurisdiction and others for whom the Client is responsible, Stantec does not warrant the services to any third party. The report may not be relied upon by any other party without the express written consent of Stantec, which may be withheld at Stantec’s discretion.



Prepared by _____

Michael Wu, EIT



Reviewed by _____

Alyssa Gladish, EIT



Approved by _____

Neal Cody, P.Eng.



Table of Contents

1.0	INTRODUCTION	1
2.0	REFERENCES	2
3.0	POTABLE WATER SERVICING	2
3.1	BACKGROUND.....	2
3.2	WATER DEMANDS.....	2
3.2.1	Domestic Water Demands	2
3.2.2	Fire Flow Demands.....	3
3.2.3	Boundary Conditions.....	3
3.3	PROPOSED SERVICING.....	4
4.0	WASTEWATER SERVICING	4
4.1	BACKGROUND.....	4
4.2	DESIGN CRITERIA.....	5
4.3	WASTEWATER GENERATION AND SERVICING DESIGN	5
4.4	PROPOSED SANITARY SERVICING	5
5.0	STORMWATER MANAGEMENT	6
5.1	OBJECTIVES	6
5.2	SWM CRITERIA AND CONSTRAINTS	6
5.3	EXISTING CONDITIONS	7
5.3.1	Allowable Release Rate	8
5.4	STORMWATER MANAGEMENT	8
5.4.1	Quantity Control	8
5.4.2	Results.....	11
5.5	QUALITY CONTROL.....	12
5.6	PROPOSED STORMWATER SERVICING	12
6.0	SITE GRADING AND DRAINAGE	12
7.0	UTILITIES	13
8.0	APPROVALS/PERMITS	13
9.0	EROSION AND SEDIMENT CONTROL DURING CONSTRUCTION	14
10.0	GEOTECHNICAL INVESTIGATION	14
11.0	CONCLUSIONS	15
11.1	WATER SERVICING.....	15
11.2	WASTEWATER SERVICING	15
11.3	STORMWATER SERVICING AND MANAGEMENT	16
11.4	GEOTECHNICAL CONSIDERATIONS	16
11.5	GRADING	17



11.6 UTILITIES17

LIST OF TABLES

Table 3-1: Estimated Water Demands 3
 Table 3-2: Boundary Conditions 4
 Table 4-1: Estimated Wastewater Peak Flow 5
 Table 5-1: Target Release Rates 8
 Table 5-2: Roof Control Area (ROOF-1)..... 9
 Table 5-3: Peak Post-Development Uncontrolled Surface Release Rates.....10
 Table 5-4: Peak Post-Development Drain Discharge Rates10
 Table 5-5: Summary of Total 2-Year and 100-Year Event Release Rates.....11
 Table 5-6: Comparison of Pre- to Post-Development Release Rate to 283 & 285 McLeod 11

LIST OF FIGURES

Figure 1: Location Map 1

LIST OF APPENDICES

APPENDIX A POTABLE WATER SERVICINGA.1
 A.1 Water Demand Calculations A.1
 A.2 Fire Flow Requirements per FUS 2020 Guidelines A.2
 A.3 Boundary Conditions A.3
 A.4 Site Plan Hydraulic Analysis Sheet..... A.4
 A.5 Correspondence Confirming Proposed Building Construction A.5

APPENDIX B PROPOSED SITE PLAN B.1

APPENDIX C WASTEWATER SERVICING..... C.1
 C.1 Preconsultation with City of Ottawa C.1
 C.2 Sanitary Sewer Calculation Sheet C.2

APPENDIX D STORMWATER SERVICING AND MANAGEMENT D.1
 D.1 Modified Rational Method Calculations..... D.1
 D.2 Predevelopment Time of Concentration Calculation D.2
 D.3 Watts Adjustable Accutrol Weir detail (2016)..... D.3
 D.4 Correspondence with the City of Ottawa Staff -Stormwater Management Approach (2022.12.08)..... D.4

APPENDIX E EXTERNAL REPORT E.1
 E.1 Geotechnical Investigation, Rev.01 By Paterson Group Inc (July 2021) E.1
 E.2 Geotechnical Memo by Paterson Group (October 2022) E.2

APPENDIX F COMPLETED DEVELOPMENT SERVICING STUDY CHECKLIST F.1



Introduction

1.0 INTRODUCTION

Stantec Consulting Ltd. has been commissioned by REZY Properties Inc. to prepare the following site servicing and stormwater management (SWM) report in support of Official Plan Amendment (OPA) and Zoning By-law Amendment (ZBLA) applications for the proposed 5-storey residential development at 283 and 285 McLeod Street in the City of Ottawa.

The subject property is approximately 832 m² in area containing two existing buildings (see **Figure 1**). Both existing buildings will be demolished. Colizza Bruni Architecture Inc. have prepared a site plan to support the Official Plan Amendment and Zoning By-law Amendment applications. The site plan shows the amalgamation of Lots 283 and 285 (see **Appendix B**). The proposed building will have two portions, the five-storey portion along the full length of the rear of the building, and two three-storey portions at the front (separated by the parking garage ramp) which mimic the appearance of two houses. The building includes basement-level parking with provision for 8 cars and 16 bike storage spots. The proposed development consists of 31 residential units with indoor and outdoor amenity areas serving a projected population of 53 people.



Figure 1: Location Map

The site is located within a combined sewer area and will be serviced by the existing municipal infrastructure on McLeod Street. The intent of this report is to provide a servicing scenario for the site that is free of conflicts, provides servicing in accordance with City of Ottawa design guidelines, and utilizes the existing local infrastructure in accordance with the criteria outlined per consultation with city staff.



References

2.0 REFERENCES

Documents referenced in preparation of this servicing and stormwater management study include:

- *City of Ottawa Design Guidelines - Water Distribution*, City of Ottawa, July 2010 (as amended, including all subsequent technical bulletins).
- *City of Ottawa Sewer Design Guidelines (SDG)*, City of Ottawa, October 2012 (as amended, including all subsequent technical bulletins).
- *Geotechnical Investigation - Proposed Multi-Storey Building, 283 & 285 McLeod Street, Ottawa, ON*, Paterson Group Inc, July 2021.
- *Geotechnical Investigation Memorandum – Response to City Comments, Proposed Multi-Storey Building, 283-285 McLeod Street, Ottawa, ON*, Paterson Group Inc., October 2022.
- *Sewer Use (By-law No. 2003-514)*, City of Ottawa, January 2003 (as amended)
- *Topographical Plan of Survey – Part of Lots 2 and 3 (East O'Connor Street) and Lot 10 (North McLeod Street), Registered Plan 30, City of Ottawa, Annis, O'Sullivan, Vollebekk Ltd., April 2018*

3.0 POTABLE WATER SERVICING

3.1 BACKGROUND

The property is located within the City's Pressure Zone 1W. The proposed development comprises a 5-storey residential apartment building consisting of 31 residential units with indoor and outdoor amenity areas. The site is currently serviced using two separate water service connections fed from the existing 203 mm diameter (dia.) watermain on McLeod Street. The City requires a single service connection for properties built on combined lot areas with less than 50 dwelling units; therefore, the proposed development will be serviced by a new single water service connection off McLeod Street. Average ground elevations of the site are approximately 71 m. Under normal operating conditions, hydraulic grade lines vary from approximately 106.4 m to 115.3 m as confirmed through boundary conditions provided by the City of Ottawa (see **Appendix A.3**).

3.2 WATER DEMANDS

3.2.1 Domestic Water Demands

The proposed five-storey with basement building consists of five (5) bachelor units, thirteen (13) one-bedroom units, two (2) one-bedroom units with dens, ten (10) two-bedroom units, and one (1) two-bedroom unit with den. The Ministry of Environment's Design Guidelines for Drinking Water Systems (2008), the Ottawa Design Guidelines – Water Distribution (July 2010) and ISTB 2021-03 Technical Bulletin were used to determine water demands based on projected population densities for residential areas. The populations were estimated using an occupancy of 1.4 persons per unit for bachelor and one-bedroom apartments, and 2.1 persons per unit for two-bedroom apartments. The proposed residential apartment building was estimated to have a total projected population of 53 persons.



Potable Water Servicing

A daily rate of 280 L/cap/day has been used to estimate average daily (AVDY) potable water demands for the residential units, and 28,000 L/ha/day for amenity space. The City Water Design Guidelines were used to estimate peak demand rates for the site as follows: Maximum day (MXDY) demands were determined by multiplying the AVDY demands by a factor of 2.5 for residential areas and 1.5 for amenity areas. Peak Hourly (PKHR) demands were determined by multiplying the MXDY demands by a factor of 2.2 for residential areas and 1.8 for amenity areas.

The estimated domestic demands are summarized in

Table 3-1 below and detailed in **Appendix A.1**.

Table 3-1: Estimated Water Demands

Demand Type	Population	Area (m²)	AVDY (L/s)	MXDY (L/s)	PKHR (L/s)
Residential	53	-	0.17	0.43	0.93
Communal Amenity Space	-	249	0.01	0.01	0.02
Total Site:	53	-	0.18	0.44	0.95

3.2.2 Fire Flow Demands

The fire flow demand was calculated in accordance with the Fire Underwriter’s Survey (FUS) methodology following the 2020 FUS Guidelines. As no on-site watermains or fire hydrants are proposed for the current development, the FUS guidelines are acceptable for this purpose. The FUS estimate was based on correspondence with the architect regarding the building construction (refer to **Appendix A.5**) which was determined to be a Type III – Ordinary Construction/Type IV-C – Mass Timber Construction with unprotected openings. The effective floor area was estimated as the sum of all above-ground floor areas. It is anticipated that the building will be sprinklered. Required fire flows were determined to be approximately 166.67 L/s (10,000 L/min) (see calculations in **Appendix A.2**).

3.2.3 Boundary Conditions

The potable water demands and fire flow requirements for the proposed development fall within the range of water demands identified in July 2021 and December 2022. The hydraulic grade lines (HGL) shown in **Table 3-2** and **Appendix A.3** were interpolated from the boundary conditions provided by the City of Ottawa on July 29th, 2021 and December 6th, 2022. This interpolation is reasonable for this functional (high-level) servicing study because the potable water demands vary only slightly from the December 6th, 2022, demands used for the boundary condition request. The interpolated hydraulic boundary conditions have been used to determine the residual watermain pressures available from the 203 mm dia. watermain on McLeod Street under various operating conditions.



Wastewater Servicing

Table 3-2: Boundary Conditions

	Hydraulic Grade Line (m) Connection at McLeod Street
Min. HGL (m)	106.4
Max. HGL (m)	115.3
Max. Day + Fire Flow (166.7 L/s) (m)	101.5

3.3 PROPOSED SERVICING

The proposed finished floor elevation for the Level 01 dwelling units at the front of the building (72.30 m) will serve as the ground floor elevation (GFE) for the calculation of residual pressures. Based on the boundary conditions and the GFE, on-site pressures are expected to range from 334.7 kPa (48.5 psi) to 421.6 kPa (61.1 psi) under normal operating conditions. These values are within the normal operating pressure range as defined by City of Ottawa design guidelines which desires 50 to 80 psi and not less than 40 psi. Booster pumps internal to the building will be required to provide adequate pressures for upper stories. These pumps are to be designed by the buildings' mechanical consultant.

Under fire flow conditions the water service must provide adequate flow and pressure to meet both the anticipated maximum daily demand (0.45 L/s) and fire flow requirements as per the FUS methodology (**Appendix A.2**) of 166.67 L/s. Considering the GFE of 72.30, the boundary conditions provided by the City of Ottawa indicate that the 203 mm dia. watermain within McLeod Street is expected to maintain a residual pressure of 29.3 m equivalent to 286.3 kPa (41.5 psi) under the specified fire flow conditions. This demonstrates that the existing watermain and nearby hydrants can provide the designed fire flows while maintaining a residual pressure of 20 psi. The nearest existing hydrant fronting the site on McLeod Street is about 45 m east from the main building entrance. A Siamese connection has been provided on the east face of the building and is situated less than 45 m from the hydrant, conforming with the OBC and the City of Ottawa requirements.

The existing water service connections to the existing buildings will be removed and blanked at the main according to the City's standards. A new 150 mm diameter water service connection to the building will be introduced. The mechanical consultant or plumbing contractor will ultimately be responsible to confirm building pressures and proposed service size are adequate to meet building code requirements.

4.0 WASTEWATER SERVICING

4.1 BACKGROUND

The site will be serviced from the existing 525 mm diameter combined sewer within the McLeod Street ROW (see **Drawing SSGP-1**). The existing buildings on 283 and 285 McLeod Street are currently separately serviced by two sanitary service laterals, which will be capped and abandoned according to the City of Ottawa standards.



Wastewater Servicing

4.2 DESIGN CRITERIA

As outlined in the City of Ottawa Sewer Design Guidelines (as amended) and the MOE Design Guidelines for Sewage Works, the following criteria were used to calculate projected wastewater flow rates and to size the sanitary sewer lateral:

- Minimum velocity = 0.6 m/s (0.8 m/s for upstream sections)
- Maximum velocity = 3.0 m/s
- Manning roughness coefficient for all smooth wall pipes = 0.013
- Minimum size of sanitary sewer service = 135 mm
- Minimum grade of sanitary sewer service = 1.0 % (2.0 % preferred)
- Average wastewater generation = 280 L/person/day (per City Design Guidelines)
- Peak Factor = based on Harmon Equation; maximum of 4.0 (residential)
- Harmon correction factor = 0.8
- Infiltration allowance = 0.33 L/s/ha (per City Design Guidelines)
- Minimum cover for sewer service connections – 2.0 m
- Population density for one-bedroom and bachelor apartments – 1.4 persons/apartment
- Population density for two-bedroom apartments – 2.1 persons/apartment

4.3 WASTEWATER GENERATION AND SERVICING DESIGN

The proposed 0.082 ha site will consist of a five-storey plus basement residential apartment building consisting of 5 bachelor units, 17 one-bedroom units, and 9 two-bedroom units with a projected population of 53 persons. The anticipated wastewater peak flow generated from the proposed development is summarized in **Table 4-1** below, with detailed calculations included in **Appendix C.2**.

Table 4-1: Estimated Wastewater Peak Flow

Residential/Amenity Peak Flows					Infiltration Flow (L/s)	Total Peak Flow (L/s)
Demand Type	No. of Units/ Area (ha)	Population	Peak Factor	Peak Flow (L/s)		
Residential	31 units	53	3.45	0.59	0.03	0.63
Amenity	0.025 ha	-	1.50	0.01		

4.4 PROPOSED SANITARY SERVICING

A 200 mm diameter sanitary building service, complete with full port backwater valve as per City Standard Drawing S14.1, is proposed for the sanitary sewage from the proposed development. Final sizing of the lateral is to be confirmed by the mechanical consultant. Full port backwater valves are to be installed on all sanitary services within the site to prevent any surcharge from the downstream sewer from impacting the proposed development.



Stormwater Management

The proposed sanitary lateral for the property will be installed below the raft slab to provide a gravity outlet for the basement level and all floors above grade. See **Drawing SSGP-1** for further details of the sewer connection. Furthermore, floor drains will be installed in the parking garage to collect wastewater and convey it to the building's sanitary service lateral.

The service lateral size is less than half of the existing municipal combined sewer within the McLeod Street ROW; therefore, a manhole is not required at the connection to the combined sewer. As per Section 14 of the Sewer Use By-law, internal test ports will be provided for the service lateral. Final sizing of the lateral is to be confirmed by the mechanical consultant.

5.0 STORMWATER MANAGEMENT

5.1 OBJECTIVES

The objective of this stormwater management plan is to determine the measures necessary to control the quantity and quality of stormwater released from the proposed development to criteria established during the pre-consultation, discussions with City of Ottawa staff, and City of Ottawa Sewer Design Guidelines (as amended). The intent is to provide a functional stormwater management plan providing sufficient detail to support the Official Plan Amendment and Zoning By-law Amendment processes.

5.2 SWM CRITERIA AND CONSTRAINTS

Criteria were established by combining current design practices outlined by the City of Ottawa Design Guidelines (2012, as amended), and through consultation with City of Ottawa staff. The following summarizes the criteria, with the source of each criterion indicated in brackets:

General

- Use of the dual drainage principle (City of Ottawa).
- Wherever feasible and practical, site-level measures should be used to reduce and control the volume and rate of runoff. (City of Ottawa)
- Assess impact of 100-year event outlined in the City of Ottawa Sewer Design Guidelines on major and minor drainage system (City of Ottawa)
- The proposed site is not subject to quality control criteria due to the small site size (less than 0.1 ha) and proposed land usage of the development (City of Ottawa).

Storm Sewer & Inlet Controls

- Size storm sewers to convey 2-year storm event under free-flow conditions using City of Ottawa I-D-F parameters (City of Ottawa).
- Site discharge rates for each storm event to be restricted to 2-year storm event pre-development rates with a maximum pre-development C coefficient of 0.4 (City of Ottawa).
- Peak stormwater discharge rates during wet weather events to be further reduced by peak calculated sanitary discharge from the site (City of Ottawa).



Stormwater Management

- Proposed site to discharge into the existing 525 mm dia. combined sewer within McLeod Street which drains to the Rideau Canal trunk sewer and into the interceptor Sewer at Wellington Street (City of Ottawa).
- $T_c = 20$ minutes or less can be calculated; T_c should be not less than 10 minutes since IDF curves become unrealistic at less than 10 min (City of Ottawa).
- A separate storm sewer lateral is required for the reverse sloped ramp to the parking garage (depressed driveway) trench drain (SDG Section 5.7.6).

Surface Storage & Overland Flow

- Any storm events greater than 2 years, up to and including 100-year storm event must be detained on site. (City of Ottawa, Pre-consultation)
 - As per consultation with the City of Ottawa staff (08-Dec-2022) it has been permitted to match post- to pre-development flows, provide storage/control through optimization of rooftop storage, and allow a portion of the site to drain uncontrolled to the McLeod Street right of way, directed to the nearby catch basins (refer to **Appendix D.4**).
- Building openings to be a minimum of 0.30 m above the 100-year water level (City of Ottawa)
- Maximum depth of flow under either static or dynamic conditions shall be less than 0.30 m (City of Ottawa)

The outlet for the sanitary and storm systems for this site is the combined sewer within McLeod Street. The City of Ottawa has required separate connections for each of the services to the combined sewer. As such, separate sanitary and storm service connections have been proposed. The combined sewer connections to the existing buildings will be removed in accordance with the City of Ottawa's infrastructure requirements. Full port backwater valves will be installed on sanitary and storm building services.

5.3 EXISTING CONDITIONS

The existing grading and drainage of the subject site was analyzed to develop an Existing Conditions Storm Drainage Plan (see **Drawing EX.SD-1**) and delineate the existing drainage subcatchments. Under the existing conditions, the site drains entirely uncontrolled toward the McLeod Street ROW; hence, only one pre-development subcatchment area (EX-1, 0.083 ha) was delineated. The existing surfaces in the EX.SD-1 plan were assigned a runoff coefficient of 0.90 for hard surfaces, and 0.20 for soft surfaces. These coefficients were area-weighted and used to estimate the overall site pre-development runoff coefficient of $C=0.77$.

Time of concentration (T_c) for the predevelopment area was calculated as 3.41 minutes using the Federal Aviation Administration (FAA) (1970) method (see **Appendix D.2**). As recommended by the city in the pre-consultation notes (see **Appendix C.1**) a T_c of 10 minutes was assigned to the site as values below 10 minutes become unrealistic.



Stormwater Management

5.3.1 Allowable Release Rate

Based on pre-consultation with City of Ottawa staff, the peak post-development discharge from the subject site is to be limited to that of the 2-year event discharge under pre-development conditions, to a maximum runoff coefficient C of 0.4, and reduced further by the estimated peak sanitary discharge from the site. The pre-development release rate for the area has been determined using the rational method based on the criteria above. Runoff coefficient (C) values have been increased by 25% for the post-development 100-year storm event based on MTO Drainage Manual recommendations. Peak flow rates have been calculated using the rational method as follows:

$$Q = 2.78 CiA$$

Where:

Q = peak flow rate, L/s

C = site runoff coefficient

i = rainfall intensity, mm/hr (as per Ottawa IDF curves)

A = drainage area, ha

The pre-development 2-year release rate (calculated with a site runoff coefficient of 0.4) less the peak sanitary discharge is the allowable stormwater release rate for the site, as shown in **Table 5-1** below.

Table 5-1: Target Release Rates

Design Storm	2-Year Pre-Dev Rate (L/s)	Peak Sanitary Discharge (L/s)	Allowable Storm Release Rate (L/s)
All Events	7.07	0.63	6.44

5.4 STORMWATER MANAGEMENT

The Modified Rational Method was employed to assess the rate and volume of runoff generated during post-development conditions. The site was divided into eight (8) drainage areas (i.e., 7 sub-catchments and a roof storage). A summary of subareas and runoff coefficients is provided in **Appendix D.1** and **Drawing SD-1**.

5.4.1 Quantity Control

The site requires quantity control measures to meet the restrictive stormwater release criteria. It is proposed that rooftop storage via restricted roof release be used to reduce site peak outflow.

5.4.1.1 Rooftop Storage

It is proposed to maximize the retention of stormwater on the building rooftop by installing restricted flow roof drains. The following calculations assume the roof will be equipped with five (5) standard Watts Roof Drains with Adjustable Accutrol (flow control) Weirs or approved equivalent, see **Appendix D.3** for Accutrol weir data sheet.



Stormwater Management

Watts Drainage “Accutrol” roof drain weir data has been used to calculate a practical roof release rate, detention storage depth and storage volume for the rooftop. It should be noted that the “Accutrol” weir has been used as an example only, and that other products may be specified for use, provided that the total roof drain release rate is restricted to match the maximum rate of release indicated in **Table 5-2**, and that sufficient roof storage is provided to meet (or exceed) the resulting volume of detained stormwater. Proposed drain release rates have been calculated based on all Accutrol weir openings set to the “closed” position. Storage volume and controlled release rates were calculated using the MRM method as shown in **Appendix D.1** and are summarized in **Table 5-2**:

Table 5-2: Roof Control Area (ROOF-1)

Design Storm	Depth (mm)	Discharge (L/s)	Volume Stored (m ³)	Available Storage (m ³)
2-Year	94.03	1.58	3.58	14.00
100-Year	149.73	1.58	13.94	

5.4.1.2 Other Storage Opportunities

The rooftop storage accounts for approximately 48 % of the storage volume required to comply with the restrictive stormwater release rates for this site. In the first submission of this report, a cistern was proposed to be located beneath the basement slab to provide additional onsite detention storage and to reduce peak outflow to the target rate. Due to the geotechnical requirements to use a mud slab on the exposed clay during excavation and a raft slab foundation due to challenging subgrade soil conditions, it is no longer feasible to situate a cistern within the building footprint.

Other stormwater management techniques were considered for this site, including infiltration, LID, and underground storage. Due to the presence of marine clay soils, there is limited infiltration potential at this site; hence many LID and infiltration techniques are not practical. Based on the latest Site Plan, underground storage is only feasible at one location on-site, beneath the reverse-slope ramp to the basement parking garage. This would require maintenance/monitoring manhole equipped with an ICD to be situated in the driveway. The addition of a manhole cover within the driveway pavers does not benefit the visual appeal of the frontage and works against the strict directives from Heritage and Urban Planning for this site. An underground storage tank or storage pipe releasing to the combined sewer introduces additional risks of surcharging the municipal sewer (that may already be near capacity); concerns regarding the elevated hydraulic grade lines; and odour and backflow issues.

It was determined that due to the numerous development constraints on-site, alternate stormwater management opportunities were not feasible. The site is less than 0.1 ha in total area, and the roof storage area occupies most (40.2 %) of the site. **On this basis, a request was made to the City of Ottawa Staff to reduce the stormwater management criteria, allowing for roof-only control and the remaining site area to drain uncontrolled to the McLeod Street ROW. This approach has been allowed for this site, provided the uncontrolled flow is directed to the existing catch basins in the roadway.** See **Appendix D.4** for correspondence with the City of Ottawa Staff regarding the stormwater management approach.



Stormwater Management

5.4.1.3 Uncontrolled Drainage

There are two uncontrolled subcatchment areas, UNC-1 and UNC-2, which drain the rear, side, front and peaked roof areas, on the east and west sides of the building, respectively. These two areas drain south to the McLeod Street ROW via surface flows and are directed toward the existing roadway catch basins (CBs). The peak post-development release rates from the uncontrolled areas are summarized in **Table 5-3**.

Table 5-3: Peak Post-Development Uncontrolled Surface Release Rates

Design Storm	Release Rate (L/s)		
	UNC-1	UNC-2	Total
2-Year	4.87	2.25	7.13
100-Year	13.32	5.96	19.28

The reverse sloped ramp to the parking garage is considered a depressed driveway. A trench drain has been provided at the bottom of the ramp to provide an outlet for the driveway area (DRAIN-1 subcatchment). As per Section 5.7.6 of the City SDG (as amended), a separate stormwater service lateral is proposed to connect the trench drain by gravity to the combined sewer. A full port backwater valve will be provided on this lateral to prevent surcharge from the combined municipal sewer entering the garage. A plan for emergency overflow of the trench drain will be provided at the detailed design phase.

There are four other building areas lower than the surface grade, including basement level entrances and exits, sunken patios/terraces and the depressed outdoor amenity area in the rear yard as represented by subcatchments DRAIN-2 to DRAIN-5. One catch basin (CB)/area drain is proposed to provide an outlet for each area and limit surface ponding. These CBs will be connected to internal servicing and ultimately contribute to the main building stormwater service lateral and outlet to the 525 mm diameter municipal combined sewer. It is critical that these drains are always kept clean and clear of debris. Assuming unrestricted flow, the discharges from the area drains are summarized in **Table 5-4**.

Table 5-4: Peak Post-Development Drain Discharge Rates

Subcatchment Area	2-Year Discharge (L/s)	100-Year Discharge (L/s)
DRAIN-1	0.58	1.49
Total Trench Drain	0.58	1.49
DRAIN-2	0.19	0.50
DRAIN-3	0.19	0.50
DRAIN-4	0.19	0.50
DRAIN-5	0.58	1.49
Total Area Drains	1.15	2.99



Stormwater Management

5.4.2 Results

A summary of the peak design discharge rates calculated from the MRM analysis (see **Appendix D.1**) is provided in **Table 5-5** below. The table shows that under peak conditions, the total flows to the combined sewer are below the target release rate of 6.44 L/s; however, the uncontrolled surface areas exceed the 2-year target release rate for the site.

Table 5-5: Summary of Total 2-Year and 100-Year Event Release Rates

Drainage Areas	2-Year Peak Discharge (L/s)	100-Year Peak Discharge (L/s)
Controlled Roof Area	1.58	1.58
Uncontrolled Area Drains	1.15	2.98
Subtotal to STM Lateral 1	2.73	4.56
Uncontrolled Trench Drain	0.58	1.49
Subtotal to STM Lateral 2	0.58	1.49
Total STM to Sewer	3.31	6.04
Uncontrolled Surface Areas	7.13	19.28
Total Site	10.43	25.32
Target	6.44	6.44
Exceedance	3.99	18.88

The noted exceedance and uncontrolled surface flows is believed to be acceptable for this site given its size (less than 0.1 ha) and proximity to the receiving waterbody of the major system (located less than one kilometer from the Rideau Canal). The development of the property and the addition of rooftop storage provides a significant improvement compared to existing conditions. The table below (**Table 5-6**) compares the pre-to-post development stormwater release rates to demonstrate the stormwater management benefits of this development, which provides a peak discharge rate reduction of 22.6 % for the 2-year event and 19.2 % for the 100-year event.

Table 5-6: Comparison of Pre- to Post-Development Release Rate to 283 & 285 McLeod

	2-Year Peak Discharge				100-Year Peak Discharge			
	Pre-Dev. C=0.77	Post-Dev.	Difference		Pre-Dev. C=0.77	Post-Dev.	Difference	
	(L/s)	(L/s)	(L/s)	%	(L/s)	(L/s)	(L/s)	%
Uncontrolled	13.48	8.85	-4.63	-	31.34	23.74	-7.60	-
Controlled – Rooftop Storage	0	1.58	1.58	-	0	1.58	1.58	-
Total	13.48	10.43	-3.05	-22.6%	31.34	25.32	-6.02	-19.2%



Site Grading and Drainage

5.5 QUALITY CONTROL

There are no significant sources of sediments or contaminants anticipated on the site due to the proposed land use and absence of surface parking. Details for the garage drainage are to be determined by the mechanical consultant at detailed design. No additional quality control measures are required for the site based on the Site Plan provided.

5.6 PROPOSED STORMWATER SERVICING

Stormwater servicing for the building will require two (2) 200 mm diameter service laterals, each complete with full port backwater valve (BWV) as per City standard S14.1 and as shown in **Drawing SSGP-1**. The building service lateral is proposed for the foundation drain and the area drains (DRAIN 2 to DRAIN-5) with the roof drain connected to the service lateral via a wye-connection downstream of the full port backwater valve. A storm monitoring test port will be installed on the building storm service lateral as per Section 14 of the Sewer Use By-law.

The second service lateral will be for the trench drain only (DRAIN-1). Both laterals are gravity-drained and there are no requirements for stormwater sump pumps. As the size of each lateral (200 mm dia.) is less than half the size of the existing municipal combined sewer within the McLeod Street ROW (525 mm dia.), manholes are not required at the connections to the combined sewer. The downspouts from the two peaked roof areas (no available roof storage) will be released to the surface and directed south into the landscaped areas to promote infiltration.

The two window wells at the front of the building will be equipped with drains, which will be indirectly connected to the weeping tile system by discharging to the clear stone sloped towards weeping tile.

6.0 SITE GRADING AND DRAINAGE

The proposed development site measures approximately 0.083 ha in area. The topography across the site is relatively flat, and currently drains from north to south, with overland flow generally being directed to the adjacent McLeod Street ROW. A functional grading plan (see Drawing SSGP-1) has been provided to satisfy the stormwater management requirements, adhere to the geotechnical restrictions (see Section 10.0), and provide for minimum cover requirements for storm and sanitary sewers. Site grading has been established to allow for drainage towards the McLeod Street ROW. The rear of the site is bound by existing retaining walls located on the adjacent properties, which are to remain. The existing retaining wall on the east side of the property is to be removed, as it does not currently align with the property line. The grading plan includes a new concrete curb per SC1.1 along the full length of the east property line and closes off the northeast corner.

Grade raises on the site do not exceed 1.5 m as recommended in the geotechnical report. The peak dry weather HGL from the adjacent areas was identified to be 66.28 m (see **Appendix E.1**). The Finished Floor Elevation (FFE), underside of raft slab and foundation drain invert have adequate freeboard (FB) above the HGL such that the site is not expected to endure a system surcharge (backup) from the



Utilities

combined sewer; however, a BWV is to be installed on each service lateral to minimize basement flooding risks.

The preliminary location of the gas pressure regulating station (shown as a footprint /concrete pad) does not obstruct the overland flow routes (SWM) or conflict with any proposed grading or landscape features.

7.0 UTILITIES

As the subject site lies within a mature developed residential community, Hydro, Bell, Gas and Cable servicing for the proposed development should be readily available within subsurface plant and adjacent overhead utility lines within the McLeod Street ROW. Exact size, location, and routing of utilities, along with determination of any off-site works required for redevelopment, will be finalized after detailed design and design circulation.

The preliminary location of the gas pressure regulating station has been shown on the servicing drawings. Design of the gas pressure regulating station is to be completed by the mechanical consultant. This location may be subject to revision at detailed design and CUP design. The preliminary location of the gas pressure regulating station (shown as a footprint /concrete pad) does not obstruct the overland flow routes (SWM) or conflict with any proposed grading or landscape features.

8.0 APPROVALS/PERMITS

Pre-consultation with Ontario Ministry of Environment, Conservation and Parks (MECP) staff concerning Environmental Compliance Approvals (ECAs, formerly Certificates of Approval (C of A)) under the Ontario Water Resources Act is forthcoming. It is expected that a direct submission ECA will be required for approval of the proposed building service connections as they connect directly to an existing combined sewer. The Rideau Valley Conservation Authority will need to be consulted to obtain municipal approval for site development.

If the ground or surface water volumes being pumped during the construction phase are between 50,000 and 400,000 L/day, it is required to register on the Environmental Activity and Sector Registry (EASR). A minimum of two to four weeks should be allotted for completion of the EASR registration and the preparation of the Water Taking and Discharge Plan by a Qualified Person as stipulated under O.Reg. 63/16. A Permit to Take Water (PTTW) through the MECP would be required for dewatering in excess of 400,000 L/day, which is unlikely for this site. However, if a PTTW is required, at least 4 to 5 months should be allowed for completion of the application and issuance of the permit by the MECP. If blasting is used to remove the bedrock as part of the excavation for the building foundation, prior approval is required from the owners/operators of any water storage reservoir, pumping station, or water works transformer station within 200 m of the site.



Erosion and Sediment Control During Construction

9.0 EROSION AND SEDIMENT CONTROL DURING CONSTRUCTION

Erosion and sediment controls must be in place during construction. The following recommendations to the contractor will be included in contract documents.

1. Implement best management practices to provide appropriate protection of the existing and proposed drainage system and the receiving watercourse(s).
2. Limit extent of exposed soils at any given time.
3. Re-vegetate exposed areas as soon as possible.
4. Minimize the area to be cleared and grubbed.
5. Protect exposed slopes with plastic or synthetic mulches.
6. Install silt barriers/fencing around the perimeter of the site as indicated in **Drawing ECDS-1** to prevent the migration of sediment offsite.
7. Install track out control mats (mud mats) at the entrance/egress to prevent migration of sediment into the public ROW.
8. Provide sediment traps and basins during dewatering works.
9. Install sediment traps (such as SiltSack® by Terrafix) between catch basins and frames.
10. Plan construction at proper time to avoid flooding.

The contractor will also be required to complete inspections and guarantee the proper performance of their erosion and sediment control measures at least after every rainfall. The inspection is to include:

1. Verification that water is not flowing under silt barriers.
2. Clean and change catch basin sediment traps.

Refer to **Drawing ECDS-1** for the proposed location of silt fences, sediment traps, and other erosion control measures.

10.0 GEOTECHNICAL INVESTIGATION

A Geotechnical Investigation Memo was prepared by Paterson Group on October 17, 2022, as a follow-up to the Revision 1 of the Report prepared on July 22nd, 2021 and is provided in **Appendix E.1**. The report summarizes the findings of the September 2020 field investigation, subsequent soil sample analyses, and provides design and construction recommendations.



Conclusions

Subsurface soil conditions within the subject area were determined from 3 boreholes distributed across the proposed site. Generally, the subsurface profile at the test hole locations consists of an approximate 50 mm to 100 mm thickness of asphalt underlain by fill which extends to approximate depths of 2.3 m to 3.1 m below the existing ground surface. The fill was generally observed to consist of either a brown silty sand with gravel and brick or a brown silty clay.

Bedrock at the site consists of shale of the Billings formation with a drift thickness of 25 m to 50 m, and groundwater levels were observed to be well below the basement level at 7.70 m to 10.4 m depth from ground surface elevation. Due to the presence of the silty clay deposit, a permissible grade raise restriction of 1.5 m was recommended for grading at the subject site. A minimum 75 mm thick lean concrete mud slab was recommended to be placed on the undisturbed silty clay subgrade shortly after completion of the excavation to reduce the risk of disturbance of the subgrade under the traffic of workers and equipment. To minimize the exposure time and avoid disturbing/drying the silty clay, the mud slab may be completed in smaller sections. For further details, please refer to the full Paterson report in **Appendix E.1**.

11.0 CONCLUSIONS

This report provides the functional servicing and stormwater management design required to support the ZBLA/OPA applications. The completed Development Servicing Study Checklist can be found in **Appendix F**.

11.1 WATER SERVICING

Based on the supplied boundary conditions for existing watermain and calculated domestic and fire flow demands for the subject site, the watermain on McLeod Street has sufficient capacity to sustain both the required domestic and emergency fire flow demands for the development. Booster pump(s) may be required to provide adequate pressures to the building's upper stories. The proposed development requires a 150 mm diameter water service lateral, which will be connected to the existing 203 mm diameter watermain in the McLeod Street ROW. Sizing of the water service and requirements for booster pump(s) are to be confirmed by the mechanical consultant.

11.2 WASTEWATER SERVICING

The proposed site will be serviced by a gravity sewer which will direct the wastewater flows to the existing 525 mm diameter combined sewer via a proposed 200 mm diameter sanitary service lateral. Existing connections are to be removed and a full port backwater valve installed on the proposed sanitary service within the site to prevent any surcharge from the downstream sewer main from impacting the proposed property. An internal monitoring test port will be installed on the building service lateral as per Section 14 of the Sewer Use By-law. The proposed sanitary lateral for the property will provide a gravity outlet for the basement level and all floors above grade. Sizing of the sanitary service lateral is to be confirmed by the mechanical consultant.



Conclusions

11.3 STORMWATER SERVICING AND MANAGEMENT

As per the pre-consultation notes, the stormwater management criteria for this site were to control all storm events up to and including the 100-year event to the 2-year pre-development event. The release rate of stormwater to the combined sewer was to be restricted to the 2-year pre-development event less the sanitary flows. Due to numerous development constraints on the site, the original stormwater management criteria could not be met. Correspondence with the City of Ottawa staff authorized reduced stormwater management requirements for this site by allowing for roof-only control and allowing for the remainder of the site to drain uncontrolled toward the McLeod Street ROW, provided the surface flows were directed toward the existing catch basins. The proposed development maximizes available rooftop storage and stormwater detention volume.

The roof storage area will be equipped with five (5) roof drains with flow-restriction weirs set to the lowest outflow rate. Area drains connected to the building's internal servicing have been provided for all below-grade building features. A trench drain has been provided at the bottom of the ramp to the underground parking, which acts as a depressed driveway. Two 200 mm diameter storm service laterals are proposed, one for the building's foundation drain, area drains, and controlled roof drains, and the second lateral is uniquely for the underground parking ramp trench drain. Both laterals are to be gravity drained and include a full port backwater valve to prevent any surcharge from the downstream sewer main from impacting the proposed property. The roof drain is to be connected through internal plumbing to the service lateral on the downstream side of the backwater valve. An internal monitoring test port will be installed on the building service lateral as per Section 14 of the Sewer Use By-law. Sizing of the service laterals and internal plumbing is to be designed and confirmed by the mechanical consultant. Given the site is less than 0.1 ha in size, no additional quality control measures are required for the site.

11.4 GEOTECHNICAL CONSIDERATIONS

The geotechnical investigation was completed by Paterson Group in September 2020 and a revised report, dated July 22, 2021, and memo, dated October 17, 2022, was provided for reference. Subsurface soil conditions within the subject area were determined from 3 boreholes distributed across the proposed site. Generally, the subsurface profile at the test hole locations consists of an approximate 50 mm to 100 mm thickness of asphalt underlain by fill which extends to approximate depths of 2.3 m to 3.1 m below the existing ground surface. Groundwater levels were observed to be well below the basement level at 7.70 m to 10.4 m depth from ground surface elevation. Due to the presence of the silty clay deposit, a permissible grade raise restriction of 1.5 m was recommended for the site and a mud slab placed on the undisturbed silty clay subgrade was recommended to reduce the risk of disturbance of the subgrade under the traffic of workers and equipment.



Conclusions

11.5 GRADING

The proposed development site measures approximately 0.083 ha in area and is bound by existing retaining walls on the north and east sides. The topography across the site is relatively flat, and currently drains from north to south, with overland flow generally being directed to the adjacent McLeod Street ROW. Site grading has been established to allow stormwater surface drainage south to the McLeod Street ROW. The grading works include the replacement of the curb retaining wall along the east property line with a concrete curb per SC1.1.

11.6 UTILITIES

As the subject site lies within a mature developed residential community, Hydro, Bell, Gas, and Cable servicing for the proposed development should be readily available within subsurface plant and adjacent overhead utility lines within the McLeod Street ROW. Exact size, location, and routing of utilities, along with determination of any off-site works required for redevelopment, will be finalized after design circulation. Detailed design of the required utility services will be completed by the respective utility companies at the detailed design stage.



APPENDICES

Appendix A POTABLE WATER SERVICING

A.1 WATER DEMAND CALCULATIONS



283 - 285 Mcleod, Ottawa, ON - Domestic Water Demand Estimates

Site Plan provided by Colizza Bruni Architecture (2023-04-25)

Project No. 160401782

Densities as per Table 4.1 of City Guidelines:		
Apartment Units		
1 Bedroom	1.4	ppu
2 Bedroom	2.1	ppu
3 Bedroom	3.1	ppu



Building ID	Amenity areas (m ²)	No. of Units	Population	Daily Rate of Demand ^{1 2} (L/cap/day or L/ha/day)	Avg Day Demand		Max Day Demand ^{3 4}		Peak Hour Demand ^{3 4}	
					(L/min)	(L/s)	(L/min)	(L/s)	(L/min)	(L/s)
Apartment Units										
Bachelor		5	7	280	1.4	0.02	3.4	0.06	7.5	0.12
1 Bedroom		13	18	280	3.5	0.06	8.8	0.15	19.3	0.32
1 Bedroom + Den ⁵		2	4	280	0.8	0.01	1.9	0.03	4.3	0.07
2 Bedroom		10	21	280	4.1	0.07	10.2	0.17	22.5	0.37
2 Bedroom + Den ⁵		1	3	280	0.6	0.01	1.5	0.02	3.2	0.05
Amenity Areas										
	249			28000	0.48	0.01	0.7	0.01	1.3	0.02
Total Site :										
		31	53		10.8	0.18	26.5	0.44	58.0	0.95

1 Average day water demand for residential areas: 280 L/cap/d

2 Average day water demand for Amenity/common areas: 28,000 L/ha/d (based on commercial water demand rates)

3 The City of Ottawa water demand criteria used to estimate peak demand rates for residential areas are as follows:

maximum day demand rate = 2.5 x average day demand rate for residential

peak hour demand rate = 2.2 x maximum day demand rate for residential (as per Technical Bulletin ISD-2010-02)

4 Water demand criteria used to estimate peak demand rates for amenity/common areas are as follows:

maximum daily demand rate = 1.5 x average day demand rate

peak hour demand rate = 1.8 x maximum day demand rate (as per Technical Bulletin ISD-2010-02)

5 Assumption that "1 bedroom with den" has density of 2.1 ppu, "2-bedroom with den" has density of 3.1 ppu

A.2 FIRE FLOW REQUIREMENTS PER FUS 2020 GUIDELINES





FUS Fire Flow Calculation Sheet - 2020 FUS Guidelines

Stantec Project #: 160401782
 Project Name: 283-285 McLeod Street
 Date: 2023-05-09
 Fire Flow Calculation #: 1
 Description: Residential

Notes: Floor plans provided by Colizza Bruni Architecture (2023-05-08)

Step	Task	Notes							Value Used	Req'd Fire Flow (L/min)
1	Determine Type of Construction	Type III - Ordinary Construction / Type IV-C - Mass Timber Construction							1	-
2	Determine Effective Floor Area	Sum of All Floor Areas							NO	-
		495	950	950	674	674			3743	-
3	Determine Required Fire Flow	(F = 220 x C x A ^{1/2}). Round to nearest 1000 L/min							-	13000
4	Determine Occupancy Charge	Limited Combustible							-15%	11050
5	Determine Sprinkler Reduction	Conforms to NFPA 13							-30%	-5525
		Standard Water Supply							-10%	
		Fully Supervised							-10%	
		% Coverage of Sprinkler System							100%	
6	Determine Increase for Exposures (Max. 75%)	Direction	Exposure Distance (m)	Exposed Length (m)	Exposed Height (Stories)	Length-Height Factor (m x stories)	Construction of Adjacent Wall	Firewall / Sprinklered ?	-	-
		North	3.1 to 10	27.18	5	> 100	Type I-II - Unprotected Openings	YES	0%	4199
		East	3.1 to 10	20.25	2	41-60	Type V	NO	17%	
		South	> 30	0	0	0-20	Type V	NO	0%	
		West	0 to 3	16.27	2	21-49	Type V	NO	21%	
7	Determine Final Required Fire Flow	Total Required Fire Flow in L/min, Rounded to Nearest 1000L/min								10000
		Total Required Fire Flow in L/s								166.7
		Required Duration of Fire Flow (hrs)								2.00
		Required Volume of Fire Flow (m ³)								1200

A.3 BOUNDARY CONDITIONS



Nwanise, Nwanise

From: Wessel, Shawn <shawn.wessel@ottawa.ca>
Sent: Monday, July 19, 2021 2:19 PM
To: Nwanise, Nwanise
Subject: 283-285 McLeod Str. Boundary condition request
Attachments: 283-285 McLeod Street July 2021.pdf

Good afternoon Nwanise.

Please find requested information below and attached.

The following are boundary conditions, HGL, for hydraulic analysis at 283-285 McLeod Street (zone 1W) with an assumed connection to the 203 mm watermain on McLeod Street (see attached PDF for location).

Minimum HGL: 106.8 m

Maximum HGL: 115.3 m

Max Day + Fire Flow (83.3 L/s): 106.5 m

These are for current conditions and are based on computer model simulation.

Disclaimer: The boundary condition information is based on current operation of the city water distribution system. The computer model simulation is based on the best information available at the time. The operation of the water distribution system can change on a regular basis, resulting in a variation in boundary conditions. The physical properties of watermains deteriorate over time, as such must be assumed in the absence of actual field test data. The variation in physical watermain properties can therefore alter the results of the computer model simulation.

Please note that I will be away from the office August 9 – 13th.

If you require additional information or clarification, please do not hesitate to contact me anytime.

Thank you

Regards,

Shawn Wessel, A.Sc.T.,rcji

Project Manager - Infrastructure Approvals Gestionnaire de projet – Approbation des demandes d’infrastructures

Development Review Central Branch | Direction de l’examen des projets d’aménagement, Centrale
Planning, Infrastructure and Economic Development Department | Direction générale de la planification
de l’infrastructure et du développement économique
City of Ottawa | Ville d’Ottawa
110 Laurier Ave. W. | 110, avenue Laurier Ouest, Ottawa ON K1P 1J1
(613) 580 2424 Ext. | Poste 33017
Int. Mail Code | Code de Courrier Interne 01-14
shawn.wessel@ottawa.ca

 Please consider the environment before printing this email

*****Please also note that, while my work hours may be affected by the current situation and am working from home, I still have access to email, video conferencing and telephone. Feel free to schedule video conferences and/or telephone calls, as necessary.*****

This e-mail originates from the City of Ottawa e-mail system. Any distribution, use or copying of this e-mail or the information it contains by other than the intended recipient(s) is unauthorized. Thank you.

Le présent courriel a été expédié par le système de courriels de la Ville d’Ottawa. Toute distribution, utilisation ou reproduction du courriel ou des renseignements qui s’y trouvent par une personne autre que son destinataire prévu est interdite. Je vous remercie de votre collaboration.

Wu, Michael

From: Wessel, Shawn
Sent: Tuesday, 6 December, 2022 13:30
To: Gladish, Alyssa
Subject: 283/285 McLeod Resubmission
Attachments: 283-285 McLeod Street November 2022.pdf

Hello Alyssa

Water Resources Dept. apologized for the error and sent me the following:

The following are boundary conditions, HGL, for hydraulic analysis at 283-285 McLeod Street (zone 1W) with an assumed connection to the 203 mm watermain on McLeod Street (see attached PDF for location).

Minimum HGL: 106.4 m

Maximum HGL: 115.3 m

Max Day + Fire Flow (116.7 L/s): 104.5 m

These are for current conditions and are based on computer model simulation.

Disclaimer: The boundary condition information is based on current operation of the city water distribution system. The computer model simulation is based on the best information available at the time. The operation of the water distribution system can change on a regular basis, resulting in a variation in boundary conditions. The physical properties of watermains deteriorate over time, as such must be assumed in the absence of actual field test data. The variation in physical watermain properties can therefore alter the results of the computer model simulation.

If you require additional information or clarification, please do not hesitate to contact me anytime.

Thank you

Regards,

Shawn Wessel, A.Sc.T.,rcji

Pronouns: he/him | Pronom: il

Project Manager - Infrastructure Approvals

Gestionnaire de projet – Approbation des demandes d’infrastructures

Development Review Central Branch | Direction de l’examen des projets d’aménagement, Centrale
Planning, Real Estate and Economic Development Department | Direction générale de la planification des biens immobiliers et du
développement économique

City of Ottawa | Ville d'Ottawa

110 Laurier Ave. W. | 110, avenue Laurier Ouest, Ottawa ON K1P 1J1

(613) 580 2424 Ext. | Poste 33017

Int. Mail Code | Code de Courrier Interne 01-14

shawn.wessel@ottawa.ca

 Please consider the environment before printing this email

*****Please also note that, while my work hours may be affected by the current situation and am working from home, I still have access to email, video conferencing and telephone. Feel free to schedule video conferences and/or telephone calls, as necessary.*****

This e-mail originates from the City of Ottawa e-mail system. Any distribution, use or copying of this e-mail or the information it contains by other than the intended recipient(s) is unauthorized. Thank you.

Le présent courriel a été expédié par le système de courriels de la Ville d'Ottawa. Toute distribution, utilisation ou reproduction du courriel ou des renseignements qui s'y trouvent par une personne autre que son destinataire prévu est interdite. Je vous remercie de votre collaboration.

Caution: This email originated from outside of Stantec. Please take extra precaution.

Attention: Ce courriel provient de l'extérieur de Stantec. Veuillez prendre des précautions supplémentaires.

Atención: Este correo electrónico proviene de fuera de Stantec. Por favor, tome precauciones adicionales.

May 2023 Water Demands and HGL Interpolation Table

	Demand (L/s)
AVDY	0.18
MXDY	0.44
PKHR	0.95
FF	166.67

	HGL (m)
Min	106.4
Max	115.3
MXDY+FF	101.5

July 2021 Water Demands and Boundary Conditions

	Demand (L/s)
AVDY	0.28
MXDY	0.70
PKHR	1.52
FF	83.33

	HGL (m)
Min	106.8
Max	115.3
MXDY+FF	106.5

December 2022 Water Demands and Boundary Conditions

	Demand (L/s)
AVDY	0.17
MXDY	0.42
PKHR	0.91
FF	116.67

	HGL (m)
Min	106.4
Max	115.3
MXDY+FF	104.5

For 2021 and 2022 boundary conditions, please see Appendix A.3

A.4 SITE PLAN HYDRAULIC ANALYSIS SHEET





Project:	283-285 McLeod Street	No.	160401782
SITE PLAN HYDRAULIC ANALYSIS			
Revision:	01	Prepared By:	MW
Revision Date:	4-May-2023	Checked By:	

BOUNDARY CONDITIONS (BC)	
Connection at McLeod	
Site Plan Revision Date	8-May-2023
Min. HGL (m)	106.4
Max. HGL (m)	115.3
Max. Day + Fire Flow (166.67 L/s) (m)	101.5

Ground Floor Elevation (GFE) (Level 01) (m)	72.3
---	------

GROUND FLOOR (GF) PRESSURE RANGE				
	GF HGL (m)	GF Pressure (kPa)	GF Pressure (psi)	Outcome
	= BC HGL (m) - FFE (m)	= GF HGL (m) x 9.804 (kPa/m)	= GF Pressure (kPa) x 0.145 (psi/kPa)	If min <50 psi: booster pump If max >100 psi: pressure reducer
Minimum Normal	34.14	334.7	48.5	Booster Pump Required
Maximum Normal	43	421.6	61.1	No Pressure Reducer Required

Number of Floors Above Ground	5
Approximate Height of One Storey (m)	3.19
Pressure Drop Per Floor (kPa)	31.3
Pressure Drop Per Floor (psi)	4.5

RESIDUAL PRESSURE RANGE IN MULTI-LEVEL BUILDINGS			
	Residual Pressure (kPa)	Residual Pressure (psi)	Outcome
Top Floor Min	209.6	30.4	Booster Pump Required
Top Floor Max	296.5	43.0	
Maximum Number of Floors Above Ground at Minimum Pressure	1		

RESIDUAL PRESSURE UNDER FIRE FLOW CONDITIONS			
	Residual HGL (m)	Residual Pressure (kPa)	Residual Pressure (psi)
Ground Floor	29.2	286.3	41.5
Top Floor	16.44	161.2	23.4

PRESSURE CHECK		
	Pressure (kPa)	Pressure (psi)
UNDER NORMAL OPERATING CONDITIONS		
Pressure Below Minimum	<276	<40
Pressure Below Normal	276-345	40-50
Pressure Within Normal Range	345-552	50-80
Pressure Above Normal Range	552-690	80-100
Pressure Above Maximum	>690	>100
UNDER FIRE FLOW CONDITIONS		
Pressure Below Minimum	<140	<20
Acceptable Pressure	≥140	≥20

A.5 CORRESPONDENCE CONFIRMING PROPOSED BUILDING CONSTRUCTION



Gladish, Alyssa

From: James Colizza <JC@colizzabruni.com>
Sent: Monday, November 14, 2022 9:04 AM
To: Gladish, Alyssa; David Murcia
Cc: Anthony Bruni; Peter Goodeve; kevinzhang; petryshyn@fotenn.com; Wu, Michael
Subject: RE: 283 & 285 McLeod Street - Seeking Confirmation of Proposed Building Construction

Alyssa.....see comments below

JAMES COLIZZA

B.COMM B.ARCH FRAIC OAA

COLIZZA BRUNI architecture

76 CHAMBERLAIN AVE · OTTAWA · ONTARIO · K1S 1V9 · (P) 613.236.2944 · (F) 613.236.6777

From: Gladish, Alyssa <Alyssa.Gladish@stantec.com>
Sent: Friday, November 11, 2022 4:35 PM
To: David Murcia <dm@colizzabruni.com>
Cc: James Colizza <JC@colizzabruni.com>; Anthony Bruni <AB@colizzabruni.com>; Peter Goodeve <pg@goodevestructural.ca>; kevinzhang <Kevinzhang@zyerdevelopments.com>; petryshyn@fotenn.com; Wu, Michael <Michael.Wu@stantec.com>
Subject: 283 & 285 McLeod Street - Seeking Confirmation of Proposed Building Construction

Good afternoon David,

Can you please confirm the following information regarding the proposed building construction for 283 & 285 McLeod Street and provide any additional details that may be pertinent to the building's fire resistivity (such as minimum fire-resistance rating of floors, walls or openings, any intentional fire separations). This will support our OFM and FUS 2020 fire flow requirement calculations.

1. Building classification: C – Residential Occupancy, 5-storey + full basement apartment building with 31 units. (5 x bachelor, 17 x one-bedroom, 9 x two-bedroom).correct
2. What is the type of construction as defined by the FUS 2020? (see PDF page 21-22 in the attached for details).building is combination of combustible and noncombustible constructionside walls and floor between basement and ground floor are noncombustible.....remainder is combustible with conventional wood frame with 1 hour rating of floors, roof and walls
 - a. Type I – Fire Resistive Construction Non-Combustible without Fire-Resistive Ratings
 - b. Type II – Non-Combustible Construction / Type IV-A – Mass Timber Construction
 - c. Type III – Ordinary Construction / Type IV-C – Mass Timber Construction
 - d. Type IV-B – Mass Timber Construction
 - e. Type V – Wood Frame / Type IV-D – Mass Timber Construction
3. Will the building be sprinklered in Accordance with Applicable NFPA Standards?yes
4. Will the sprinkler system be *fully supervised* as defined by the FUS 2020? (see PDF page 29 in the attached for details). Yes

5. Are there any additional details pertinent to the building's fire resistivity? ...fire resistive rating between the basement and ground floor is 2hrs.

Thank you for your time.

Best regards,

Alyssa Gladish E.I.T.
Project Manager, Community Development

Direct: 780 917-8567
Mobile: 587 721-1241
Alyssa.Gladish@stantec.com

Stantec
300-1331 Clyde Avenue
Ottawa ON K2C 3G4



The content of this email is the confidential property of Stantec and should not be copied, modified, retransmitted, or used for any purpose except with Stantec's written authorization. If you are not the intended recipient, please delete all copies and notify us immediately.

Caution: This email originated from outside of Stantec. Please take extra precaution.

Attention: Ce courriel provient de l'extérieur de Stantec. Veuillez prendre des précautions supplémentaires.

Atención: Este correo electrónico proviene de fuera de Stantec. Por favor, tome precauciones adicionales.

Appendix B PROPOSED SITE PLAN



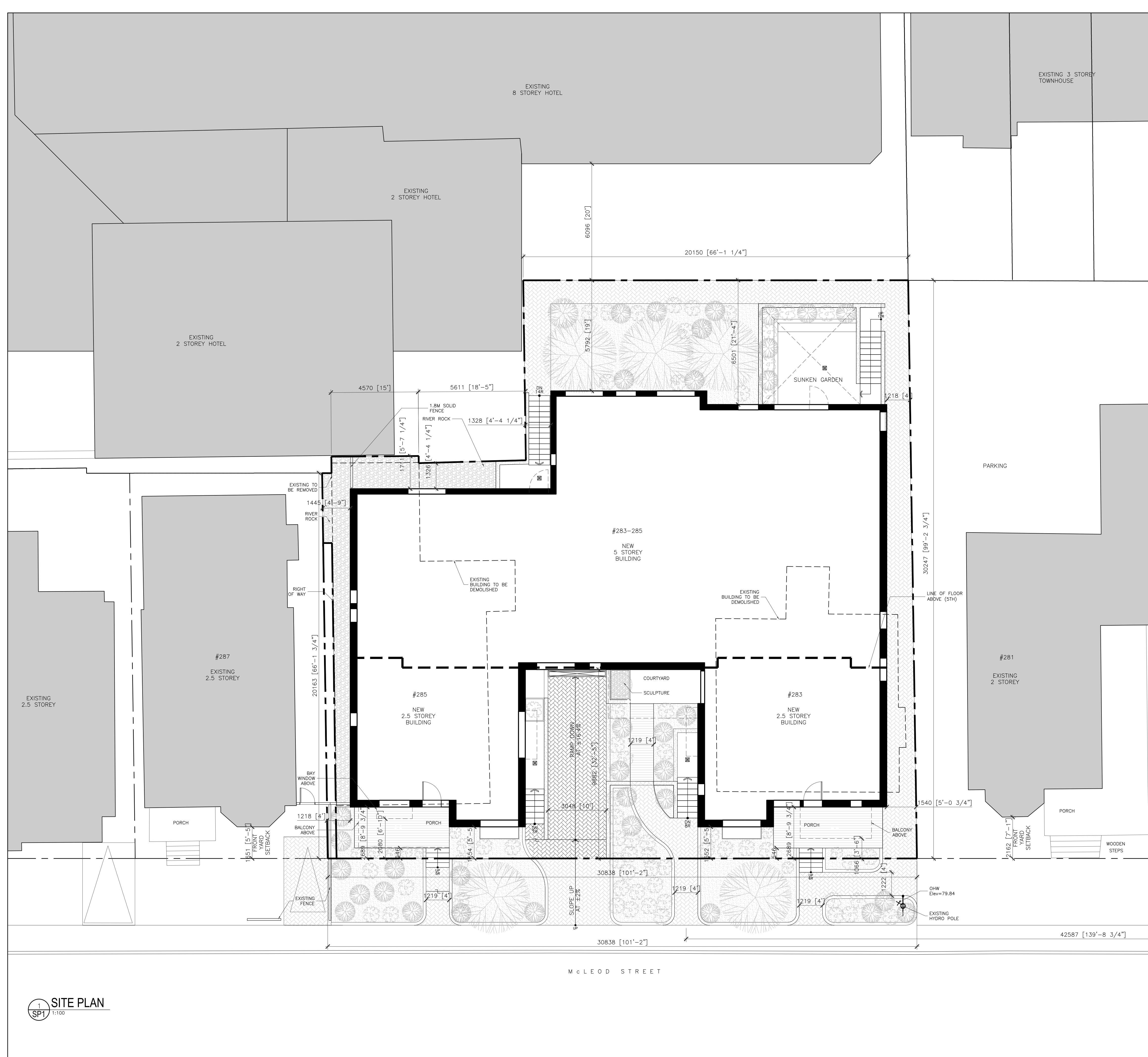

DEVELOPMENT INFORMATION			# OF UNITS
ZONING RALD (478) - RALD (479)			31
SITE AREA SQ.M	832	8955.6 SQ.FT	
% L.O.S SQ.M	253	2728 SQ.FT	30%

AREAS ABOVE GRADE		SQ.FT
TOTAL GROSS BUILDING AREA		22802
TOTAL GROSS FLOOR AREA OF APARTMENTS		18431
BUILDING EFFICIENCY ABOVE GRADE		81%

AREAS BELOW GRADE		SQ.FT
TOTAL GROSS BUILDING AREA		5205
TOTAL GROSS FLOOR AREA OF APARTMENTS		1033
BUILDING EFFICIENCY BELOW GRADE		20%

AREAS ABOVE GRADE (INCLUDING BASEMENT UNITS)		SQ.FT
TOTAL GROSS BUILDING AREA		23835
TOTAL GROSS FLOOR AREA OF APARTMENTS		19464
BUILDING EFFICIENCY		82%

PARKING AREA		UNITS
UNDERGROUND PARKING		7+1 VISITS

GROSS AREA BY FLOOR			
LEVEL	TOTAL	APART	UNITS
FIRST FLOOR	5325	3929	6
2ND & THIRD	10227	8715	13
4TH TO 5TH	7250	5787	10
BASEMENT	5205	1033	2

UNIT	AREA SQ.FT	CONFIGURATION	# OF UNITS
TYPE A	925	2BR	1
TYPE B	707	2BR	2
TYPE B2	498	1BR	1
TYPE B1 (BF)	707	2BR	2
TYPE C	454	1BR	5
TYPE D1	803	2BR	1
TYPE D2	652	1BR & DEN	1
TYPE D	628	1BR & DEN	2
TYPE E	763	2BR	1
TYPE F	953	2BR	1
TYPE G	558	1BR	1
TYPE G1 (BF)	664	1BR	2
TYPE H	434	BACHELOR	1
TYPE H1 (BF)	447	BACHELOR	1
TYPE I	850	2BR	1
TYPE J	925	2BR	1
TYPE K	421	BACHELOR	1
TYPE L	458	BACHELOR	1
TYPE M	1188	2BR & DEN	1
TYPE N	514	1BR	1
TYPE O	519	1BR	1
TYPE P	486	1BR	1
TYPE Q	388	BACHELOR	1

UNIT	# OF UNITS	REQUIRED BF 1% OF THE TOTAL # OF UNITS	PROVIDED
2BR	11	2	2
1BR	15	2	2
BACHELOR	5	1	1

AMENITY AREA	OUTDOOR (SQ.FT)	INDOOR (SQ.FT)
COMMUNAL	1785	249
PRIVATE	724	-
AMENITY AREA	SQ.FT	SQ.M
TOTAL	2758	256
REQUIRED	2003	186

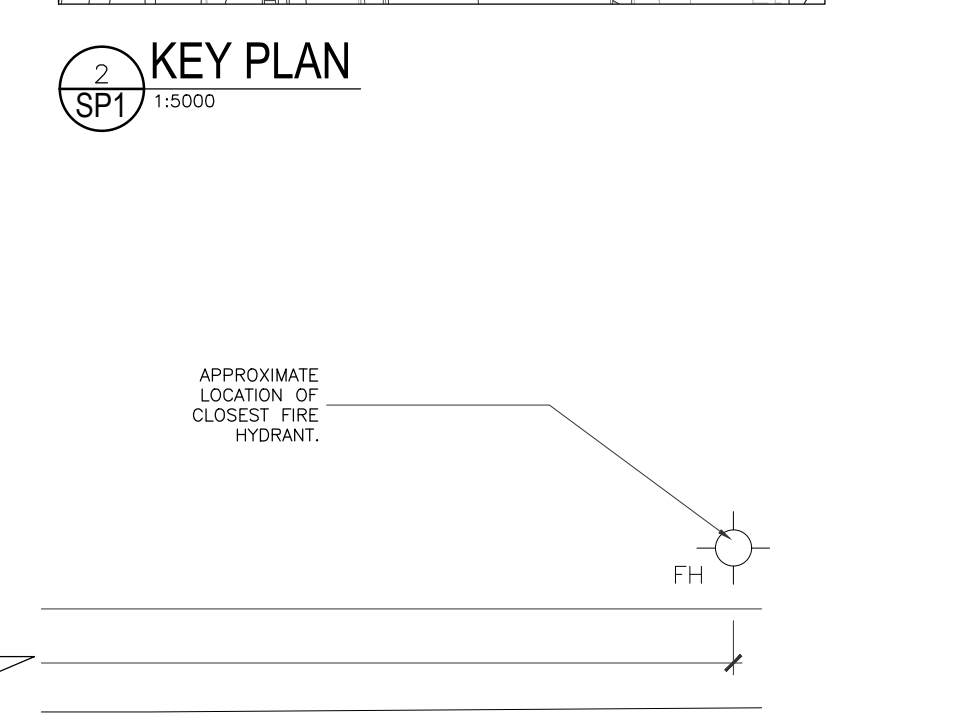

1 SITE PLAN
SPT 1:100

01 APR 25/23 FOR ZONING AMENDMENT RESUBMISSION

NO. REV. DATE REV. DESCRIPTION

COLIZZA BRUNI
architecture

76 CHAMBERLAIN AVE • OTTAWA • ONTARIO • K1S 1V9
T 613.236.2944 • F 613.236.6777 • www.colizzabruni.com

PROJECT NAME
**283 + 285 MCLEOD ST
OTTAWA, ON**

OTTAWA, ON
DRAWING TITLE
SITE PLAN

SCALE
AS NOTED
DRAWN BY
DAVID MURCIA
DATE
5/8/23
PROJECT NO.
019-17
DRAWING NO.
SP1
PLAN NO.:18721
D01-01-21-0014 & D02-02-21-0084

Appendix C WASTEWATER SERVICING

C.1 PRECONSULTATION WITH CITY OF OTTAWA



Infrastructure:

- A 203 mm dia. UCI Watermain (c. 1888) is available.
- A 525 mm dia. Conc. Combined Sewer (c. 1901) is available, which drains to the Rideau Canal . Trunk Sewer and onto the Interceptor Sewer at Wellington St.
- The following apply to this site and any development within a combined sewer area:
 - **Total** (San & Stm) allowable release rate will be 2-year pre-development rate.
 - Coefficient (C) of runoff will need to be determined **as per existing conditions** but in no case more than 0.4
 - TC = 20 minutes or can be calculated
 - TC should be not be less than 10 minutes, since IDF curves become unrealistic at less than 10 min.
 - Any storm events greater than 2 year, up to 100 year, and including 100 year storm event must be detained on site.
 - Two separate sewer laterals (one for sanitary and other for storm) will be required.
- An MECP ECA will be required.
- Please have applicant provide one copy of the following for our review:
 - MECP ECA Application Form - Direct Submission tied to SPC
 - Fees - Certified Cheque made out to "Ministry of Finance"
 - Proof of Applicant's Identification (if no Certificate of Incorporation)
 - Certificate of Incorporation (if Applicable)
 - NAICS Code (If Applicable)
 - Plan & Profile
 - Grading and Servicing Plans
 - Survey Plan
 - Pipe Data Form
 - Draft ECA (City of Ottawa Expanded Works Form)
 - Source Protection Policy Screening & Significant Threat Report
 - Sewer Drainage Area Plan
 - SWM Report
 - Services Report
 - Geotechnical Report & any other supportive documentation
 - Correspondence: City of Ottawa including ROW, Water Resources Dept., ISD etc., MNR, Conservation Authority & MECP.
- Please note that once the review has been completed and the Sr. Engineer is satisfied and ready to sign off on the application, after the PM recommendations 3 final bound copies including 3 CD Rom disks will be required to accompany the applications with MECP and for City of Ottawa records.
- Footer of ECA Application should have reference #: 8551E (2019/05)
- Please also note:
 - Foundation drains are to be independently connected to sewermain (separated or combined) unless being pumped with appropriate back up power, sufficient sized pump and back flow prevention.
 - Roof drains are to be connected downstream of any incorporated ICD within the SWM system.
 - Boundary Conditions will be provided at request of consultant after providing Average Daily Demands, Peak Hour Demands & Max Day + Fire Flow Demands

Other:

- Due to more sensitive use, a Record of Site Condition (RSC) is required. Ensure Phase I, and if applicable, Phase II ESA's speak to required RSC.
- An internal oil/grit separator will be required for car elevator sump sanitary connection and be accessible and meet all Ministry of Labour requirements – as applicable.

APPLICANT'S STUDY AND PLAN IDENTIFICATION LIST

Legend: S indicates that the study or plan is required with application submission.
 A indicates that the study or plan may be required to satisfy a condition of approval/draft approval.

For information and guidance on preparing required studies and plans refer to:

<http://ottawa.ca/en/development-application-review-process-0/guide-preparing-studies-and-plans>

S/A	Number of copies	ENGINEERING		S/A	Number of copies
S	3	1. <u>Site Servicing Plan</u>	2. <u>Assessment of Adequacy of Public Services / Site Servicing Study</u>	S	3
S	3	3. <u>Grade Control and Drainage Plan</u>	4. <u>Geotechnical Study</u>	S	3
	2	5. <u>Composite Utility Plan</u>	6. <u>Groundwater Impact Study (if over 10,000 L/day)</u>		4
	5	7. <u>Servicing Options Report</u>	8. <u>Wellhead Protection Study</u>		6
S	9	9. <u>Transportation Impact Assessment (dependent on Screening Form)</u>	10. <u>Erosion and Sediment Control Plan</u>	S	3
S	3	11. <u>Storm water Management Report</u>	12. <u>Full Hydro geological and Terrain Analysis</u>		3
	3	13. <u>Hydraulic Water main Analysis (is over 10,000 L/day)</u>	14. <u>Noise Study (environmental and stationary)</u>	S	3
	35/50/55	15. <u>Roadway Modification Design Plan</u>	16. <u>Pre-Construction/Blast Survey (Prior to Excavation & Shoring Permits)</u>	A	3

S/A	Number of copies	PLANNING / DESIGN / SURVEY		S/A	Number of copies
	50	17. <u>Draft Plan of Subdivision</u>	18. <u>Plan Showing Layout of Parking Garage</u>	S	3
	30	19. <u>Draft Plan of Condominium</u>	20. <u>Planning Rationale</u>	S	3
S	3	21. <u>Site Plan</u>	22. <u>Minimum Distance Separation (MDS) Calculations (can include in Planning Rationale)</u>		2
	20	23. <u>Concept Plan Showing Proposed Land Uses and Landscaping</u>	24. <u>Agrology and Soil Capability Study</u>		5
S	3	25. <u>Floor Plans</u>	26. <u>Cultural Heritage Impact Statement</u>	S	3
S	3	27. <u>Landscape Plan</u>	28. <u>Archaeological Resource Assessment Requirements: Dependent on results of screening form</u>		2
S	2	29. <u>Survey Plan</u>	30. <u>Shadow Analysis</u>	S	3
S	3	31. <u>Architectural Building Elevation Drawings (dimensioned)</u>	32. <u>Design Brief (includes the Design Review Panel Submission Requirements)</u>	S	3
S	3	33. <u>Wind Analysis</u>			

S/A	Number of copies	ENVIRONMENTAL		S/A	Number of copies
S	3	34. <u>Phase 1 Environmental Site Assessment</u>	35. <u>Impact Assessment of Adjacent Waste Disposal/Former Landfill Site</u>		6
S	3	36. <u>Phase 2 Environmental Site Assessment (depends on the outcome of Phase 1)</u>	37. <u>Assessment of Landform Features</u>		7
S	4	38. <u>Record of Site Condition</u>	39. <u>Mineral Resource Impact Assessment</u>		3
S	2	40. <u>Tree Conservation Report (can be combined with Landscape Plan)</u>	41. <u>Environmental Impact Statement / Impact Assessment of Endangered Species</u>		2
S	1	42. <u>PDF copy of all plans and reports</u>	43. <u>Lighting Study</u>		

Meeting Date: June 3, 2021

Application Type(s): *Site Plan Control (Complex, subject to public consultation)*

File Lead: Seana Turkington

Infrastructure Approvals Project Manager: Shawn Wessel

Site Address (Municipal Address): 283-285 McLeod Street

*Preliminary Assessment: 1 2 3 4 5

*One (1) indicates that considerable major revisions are required before a planning application is submitted, while five (5) suggests that proposal appears to meet the City's key land use policies and guidelines. This assessment is purely advisory and does not consider technical aspects of the proposal or in any way guarantee application approval.

It is important to note that the need for additional studies and plans may result during application review. If following the submission of your application, it is determined that material that is not identified in this checklist is required to achieve complete application status, in accordance with the Planning Act and Official Plan requirements, the Planning and Growth Management Department will notify you of outstanding material required within the required 30 day period. Mandatory pre-application consultation will not shorten the City's standard processing timelines, or guarantee that an application will be approved. It is intended to help educate and inform the applicant about submission requirements as well as municipal processes, policies, and key issues in advance of submitting a formal development application. This list is valid for one year following the meeting date. If the application is not submitted within this timeframe the applicant must again pre-consult with the Planning and Growth Management Department.

APPLICANT'S STUDY AND PLAN IDENTIFICATION LIST

Legend: **S** indicates that the study or plan is required with application submission.
A indicates that the study or plan may be required to satisfy a condition of approval/draft approval.

For information and guidance on preparing required studies and plans refer to:

<http://ottawa.ca/en/development-application-review-process-0/guide-preparing-studies-and-plans>

S/A	Number of copies	ENGINEERING		S/A	Number of copies
	3	1. <u>Site Servicing Plan</u>	2. <u>Assessment of Adequacy of Public Services / Site Servicing Study</u>	S	3
	3	3. <u>Grade Control and Drainage Plan</u>	4. Geotechnical Study		3
	2	5. Composite Utility Plan	6. Groundwater Impact Study (if over 10,000 L/day)		4
S	5	7. <u>Servicing Options Report</u>	8. Wellhead Protection Study		6
S	9	9. <u>Transportation Impact Assessment (dependent on Screening Form)</u>	10. Erosion and Sediment Control Plan		3
	3	11. Storm water Management Report	12. Full Hydro geological and Terrain Analysis		3
	3	13. Hydraulic Water main Analysis (is over 10,000 L/day)	14. Noise Study (environmental and stationary)	S	3
	35/50/55	15. Roadway Modification Design Plan	16.		3

S/A	Number of copies	PLANNING / DESIGN / SURVEY		S/A	Number of copies
	50	17. Draft Plan of Subdivision	18. Plan Showing Layout of Parking Garage		3
	30	19. Draft Plan of Condominium	20. Planning Rationale	S	3
	3	21. Site Plan	22. Minimum Distance Separation (MDS) Calculations (can include in Planning Rationale)		2
S	20	23. <u>Concept Plan Showing Proposed Land Uses and Landscaping</u>	24. Agrology and Soil Capability Study		5
	3	25. Floor Plans	26. Cultural Heritage Impact Statement	S	3
	3	27. Landscape Plan	28. Archaeological Resource Assessment Requirements: Dependent on results of screening form		2
S	2	29. Survey Plan	30. Shadow Analysis	S	3
S	3	31. Architectural Building Elevation Drawings (dimensioned)	32. Design Brief (includes the Design Review Panel Submission Requirements)	S	3
S	6	33. Wind Analysis			

S/A	Number of copies	ENVIRONMENTAL		S/A	Number of copies
S	3	34. Phase 1 Environmental Site Assessment	35. Impact Assessment of Adjacent Waste Disposal/Former Landfill Site		6
S	3	36. Phase 2 Environmental Site Assessment (depends on the outcome of Phase 1)	37. Assessment of Landform Features		7
S	4	38. <u>Record of Site Condition</u>	39. Mineral Resource Impact Assessment		3
	2	40. Tree Conservation Report (can be combined with Landscape Plan)	41. Environmental Impact Statement / Impact Assessment of Endangered Species		2
S	1	42. <u>PDF copy of all plans and reports</u>	43. Lighting Study		

Meeting Date: June 3, 2021

Application Type(s): *Official Plan Amendment (OPA) and Zoning By-law Amendment (ZBA)*

File Lead: Seana Turkington

Infrastructure Approvals Project Manager: Shawn Wessel

Site Address (Municipal Address): 283-285 McLeod Street

*Preliminary Assessment: 1 2 3 4 5

*One (1) indicates that considerable major revisions are required before a planning application is submitted, while five (5) suggests that proposal appears to meet the City's key land use policies and guidelines. **This assessment is purely advisory and does not consider technical aspects of the proposal or in any way guarantee application approval.**

It is important to note that the need for additional studies and plans may result during application review. If following the submission of your application, it is determined that material that is not identified in this checklist is required to achieve complete application status, in accordance with the Planning Act and Official Plan requirements, the Planning and Growth Management Department will notify you of outstanding material required within the required 30 day period. Mandatory pre-application consultation will not shorten the City's standard processing timelines, or guarantee that an application will be approved. It is intended to help educate and inform the applicant about submission requirements as well as municipal processes, policies, and key issues in advance of submitting a formal development application. This list is valid for one year following the meeting date. If the application is not submitted within this timeframe the applicant must again pre-consult with the Planning and Growth Management Department.



APPLICANT'S STUDY AND PLAN IDENTIFICATION LIST

Legend: S indicates that the study or plan is required with application submission.
 A indicates that the study or plan may be required to satisfy a condition of approval/draft approval.
 For information and guidance on preparing required studies and plans refer to:

		ENGINEERING			
S/A	Number of copies			S/A	Number of copies
S	5	1. Site Servicing Plan	2. Site Servicing Study	S	3
S	5	3. Grade Control and Drainage Plan	4. Geotechnical Study	S	3
	2	5. Composite Utility Plan	6. Groundwater Impact Study		6
S	5	7. Servicing Options Report	8. Wellhead Protection Study		6
S	9	9. Transportation Impact Study	10. Erosion and Sediment Control Plan	S	5
S	3	11. Storm water Management Report	12. Hydro geological and Terrain Analysis		8
	3	13. Hydraulic Water main Analysis	14. Noise Study	S	3
	5	15. Roadway Modification Design Plan	16. Confederation Line Proximity Study		9
		PLANNING / DESIGN / SURVEY			
S/A	Number of copies			S/A	Number of copies
	50	17. Draft Plan of Subdivision	18. Plan Showing Layout of Parking Garage	S	2
	30	19. Draft Plan of Condominium	20. Planning Rationale	S	3
S	5	21. Site Plan	22. Minimum Distance Separation (MDS)		3
S	5	23. Concept Plan Showing Proposed Land Uses and Landscaping	24. Agrology and Soil Capability Study		5
S	3	25. Concept Plan Showing Ultimate Use of Land	26. Cultural Heritage Impact Statement	S	3
S	5	27. Landscape Plan	28. Archaeological Resource Assessment Requirements: S (site plan) A (subdivision, condo)		3
S	2	29. Survey Plan	30. Shadow Analysis	S	3
S	3	31. Architectural Building Elevation Drawings (dimensioned)	32. Design Brief (includes the Design Review Panel Submission Requirements)	S	Available online
S	3	33. Wind Analysis (addendum to previous study)	34. Public Consultation Strategy: S (zoning, official plan, subdivision) may be included as part of Planning Rationale		1
		ENVIRONMENTAL			
S/A	Number of copies			S/A	Number of copies
S	5	35. Phase 1 Environmental Site Assessment	36. Impact Assessment of Adjacent Waste Disposal/Former Landfill Site		6
S	5	37. Phase 2 Environmental Site Assessment (depends on the outcome of Phase 1)	38. Assessment of Landform Features		7
A	4	39. Record of Site Condition	40. Mineral Resource Impact Assessment		4
S	5	41. Tree Conservation Report (combine with landscape plan)	42. Environmental Impact Statement / Impact Assessment of Endangered Species		11
	4	43. Mine Hazard Study / Abandoned Pit or Quarry Study	44. Integrated Environmental Review (Draft, as part of Planning Rationale)		3

Meeting Date: January 7, 2020

File Lead (Assigned Planner): S. Deiac

Site Address (Municipal Address): 283-285 McLeod

Application Type: OPA/ZBA

Infrastructure Approvals Project Manager: S. Wessel

*Preliminary Assessment: 1 2 3 4 5

*One (1) indicates that considerable major revisions are required before a planning application is submitted, while five (5) suggests that proposal appears to meet the City's key land use policies and guidelines. This assessment is purely advisory and does not consider technical aspects of the proposal or in any way guarantee application approval.

It is important to note that the need for additional studies and plans may result during application review. If following the submission of your application, it is determined that material that is not identified in this checklist is required to achieve complete application status, in accordance with the Planning Act and Official Plan requirements, the Planning, Infrastructure and Economic Development Department will notify you of outstanding material required within the required 30 day period. Mandatory pre-application consultation will not shorten the City's standard processing timelines, or guarantee that an application will be approved. It is intended to help educate and inform the applicant about submission requirements as well as municipal processes, policies, and key issues in advance of submitting a formal development application. This list is valid for one year following the meeting date. If the application is not submitted within this timeframe the applicant must again pre-consult with the Planning, Infrastructure and Economic Development Department.

110 Laurier Avenue West, Ottawa ON K1P 1J1
 110, av. Laurier Ouest, Ottawa (Ontario) K1P 1J1

Mail code: 01-14
 Courrier interne : 01-14

Visit us: Ottawa.ca/planning
 Visitez-nous: Ottawa.ca/urbanisme

C.2 SANITARY SEWER CALCULATION SHEET





SITE:
283 - 285 McLeod Street, Ottawa, ON

DATE: 2023-04-27
 REVISION: 1
 DESIGNED BY: MW
 CHECKED BY: AG

**SANITARY SEWER
 DESIGN SHEET
 (City of Ottawa)**

FILE NUMBER: 160401782

DESIGN PARAMETERS			
MAX PEAK FACTOR (RES.)=	4.0	AVG. DAILY FLOW / PERSON	280 l/p/day
MIN PEAK FACTOR (RES.)=	2.0	COMMERCIAL	28,000 l/ha/day
PEAKING FACTOR (INDUSTRIAL):	2.4	INDUSTRIAL (HEAVY)	55,000 l/ha/day
PEAKING FACTOR (ICI >20%):	1.5	INDUSTRIAL (LIGHT)	35,000 l/ha/day
PERSONS / 1 BEDROOM	1.4	INSTITUTIONAL	28,000 l/ha/day
PERSONS / 2 BEDROOM	2.1	INFILTRATION	0.33 l/s/ha
PERSONS / 3 BEDROOM	3.1		
MINIMUM VELOCITY	0.60 m/s		
MAXIMUM VELOCITY	3.00 m/s		
MANNINGS n	0.013		
BEDDING CLASS	B		
MINIMUM COVER	2.50 m		
HARMON CORRECTION FACTOR	0.8		

LOCATION			RESIDENTIAL AREA AND POPULATION										COMM/AMENITY		INDUSTRIAL (L)		INDUSTRIAL (H)		INSTITUTIONAL		GREEN / UNUSED		C++I	INFILTRATION			TOTAL	PIPE						
AREA ID NUMBER	FROM M.H.	TO M.H.	AREA (ha)	1 BEDROOM	2 BEDROOM	3 BEDROOM	POP.	CUMULATIVE AREA (ha)	POP.	PEAK FACT.	PEAK FLOW (l/s)	AREA (ha)	ACCU. AREA (ha)	AREA (ha)	ACCU. AREA (ha)	AREA (ha)	ACCU. AREA (ha)	AREA (ha)	ACCU. AREA (ha)	AREA (ha)	ACCU. AREA (ha)	PEAK FLOW (l/s)	TOTAL AREA (ha)	ACCU. AREA (ha)	INFILT. FLOW (l/s)	FLOW (l/s)	LENGTH (m)	DIA (mm)	MATERIAL	CLASS	SLOPE (%)	CAP. (FULL) (l/s)	CAP. V PEAK FLOW (%)	VEL. (FULL) (m/s)
PROPOSED BLDG	BLDG	EX SAN	0.049	18	12	1	53	0.049	53	3.45	0.59	0.025	0.025	0.00	0.00	0.00	0.00	0.00	0.00	0.00	0.00	0.01	0.083	0.08	0.03	0.63	8.0	200	PVC	SDR 35	1.00	33.4	1.89%	1.05

- Notes**
- Unit breakdown for proposed 5-storey residential building provided by Colizza Bruni Architecture in May 2023
 - Site to outlet to existing 525 mm dia. combined sewer on McLeod Street.
 - Entire site area considered as potential source of infiltration.

Appendix D STORMWATER SERVICING AND MANAGEMENT

D.1 MODIFIED RATIONAL METHOD CALCULATIONS



Roof Drain Design Calculation Sheet

**Project #160401782, 283 & 285 McLeod Street
Roof Drain Design Sheet, Area ROOF-1
Standard Watts Roof Drain with Adjustable Accutrol Weir**

Rating Curve				Volume Estimation				Water Depth (m)
Elevation (m)	Discharge Rate (cu.m/s)	Outlet Discharge (cu.m/s)	Storage (cu. m)	Elevation (m)	Area (sq. m)	Volume (cu. m)		
						Increment	Accumulated	
0.000	0.000000	0.0000	0.00	0.000	0	0.00	0.00	0.000
0.025	0.000315	0.0016	0.06	0.025	7.78	0.06	0.06	0.025
0.050	0.000315	0.0016	0.52	0.050	31.11	0.45	0.52	0.050
0.075	0.000315	0.0016	1.75	0.075	70.00	1.23	1.75	0.075
0.100	0.000315	0.0016	4.15	0.100	124.44	2.40	4.15	0.100
0.125	0.000315	0.0016	8.10	0.125	194.44	3.95	8.10	0.125
0.150	0.000315	0.0016	14.00	0.150	280.00	5.90	14.00	0.150

Drawdown Estimate			
Total Volume (cu.m)	Total Time (sec)	Vol (cu.m)	Detention Time (hr)
0.0	0.0	0.0	0
0.5	287.7	0.5	0.07991
1.7	780.9	1.2	0.29682
4.1	1520.6	2.4	0.71921
8.0	2507.0	4.0	1.41559
13.9	3739.9	5.9	2.45446

Rooftop Storage Summary

Total Building Area (sq.m)	350
Assume Available Roof Area (sq. m)	80% 280
Roof Imperviousness	0.99
Roof Drain Requirement (sq.m/Notch)	232
Number of Roof Notches*	5
Max. Allowable Depth of Roof Ponding (m)	0.15 * As per Ontario Building Code section OBC 7.4.10.4.(2)(c).
Max. Allowable Storage (cu.m)	14
Estimated 100 Year Drawdown Time (h)	2.5

* Note: Number of drains can be reduced if multiple-notch drain used.

Calculation Results

	2yr	100yr	Available
Qresult (cu.m/s)	0.002	0.002	-
Depth (m)	0.094	0.150	0.150
Volume (cu.m)	3.6	13.9	14.0
Drainage time (hrs)	0.6	2.5	

**Adjustable Accutrol Weir Flow Rate Settings
From Watts Drain Catalogue**

Head (m)	L/s				Closed
	Open	75%	50%	25%	
0.025	0.3154	0.3154	0.3154	0.3154	0.3154
0.05	0.6308	0.6308	0.6308	0.6308	0.3154
0.075	0.9462	0.8674	0.7885	0.7097	0.3154
0.1	1.2617	1.104	0.9462	0.7885	0.3154
0.125	1.5771	1.3405	1.104	0.8674	0.3154
0.15	1.8925	1.5771	1.2617	0.9462	0.3154

Stormwater Management Calculations

File No: **160401782**
 Project: **283 & 285 McLeod Street**
 Date: **01-May-23**

SWM Approach:
 Post-development to Pre-development flows

Post-Development Site Conditions:

Overall Runoff Coefficient for Site and Sub-Catchment Areas

Runoff Coefficient Table								
Catchment Type	Sub-catchment Area	ID / Description	Area (ha) "A"	Runoff Coefficient "C"	"A x C"	Overall Runoff Coefficient		
Uncontrolled - Non-Tributary	DRAIN-5	Hard	0.003	0.9	0.003			
		Soft	0.000	0.2	0.000			
		Subtotal			0.003		0.0027	0.900
Uncontrolled - Non-Tributary	DRAIN-4	Hard	0.001	0.9	0.001			
		Soft	0.000	0.2	0.000			
		Subtotal			0.001		0.0009	0.900
Uncontrolled - Non-Tributary	DRAIN-3	Hard	0.001	0.9	0.001			
		Soft	0.000	0.2	0.000			
		Subtotal			0.001		0.0009	0.900
Uncontrolled - Non-Tributary	DRAIN-2	Hard	0.001	0.9	0.001			
		Soft	0.000	0.2	0.000			
		Subtotal			0.001		0.0009	0.900
Roof	ROOF-1	Hard	0.035	0.9	0.032			
		Soft	0.000	0.2	0.000			
		Subtotal			0.035		0.0315	0.900
Uncontrolled - Non-Tributary	DRAIN-1	Hard	0.003	0.9	0.003			
		Soft	0.000	0.2	0.000			
		Subtotal			0.003		0.0027	0.900
Uncontrolled - Non-Tributary	UNC-2	Hard	0.012	0.9	0.010			
		Soft	0.000	0.2	0.000			
		Subtotal			0.012		0.01056	0.880
Uncontrolled - Non-Tributary	UNC-1	Hard	0.025	0.9	0.022			
		Soft	0.002	0.2	0.000			
		Subtotal			0.027		0.0228109	0.850
Total					0.083		0.073	0.88
Overall Runoff Coefficient= C:								

Total Roof Areas	0.035 ha
Total Tributary Surface Areas (Controlled and Uncontrolled)	0.009 ha
Total Tributary Area to Outlet	0.044 ha
 Total Uncontrolled Areas (Non-Tributary)	 0.039 ha
 Total Site	 0.083 ha

Stormwater Management Calculations

Project #160401782, 283 & 285 McLeod Street Modified Rational Method Calculations for Storage

2 yr Intensity City of Ottawa	$I = a/(t + b)^c$	a =	732.951	t (min)	I (mm/hr)
		b =	6.199	10	76.81
		c =	0.81	20	52.03
				30	40.04
			40	32.86	
			50	28.04	
			60	24.56	
			70	21.91	
			80	19.83	
			90	18.14	
			100	16.75	
			110	15.57	
			120	14.56	

2 YEAR Predevelopment Target Release from Portion of Site

Subdrainage Area: Predevelopment Tributary Area to Outlet
 Area (ha): 0.0628
 C: 0.40

Target stormwater release rate determined using a C of 0.4 in a 2-year event and subtracting the peak sanitary flow rate (as per preconsultation with the City).

Using a typical time of concentration of 10 minutes
 (Used Federal Aviation Administration Method (1970) to confirm that the actual predevelopment time of concentration is less than 10 minutes)

tc (min)	I (2 yr) (mm/hr)	Qexisting (L/s)
10	76.81	7.07

Subtracting the peak sanitary discharge of: 0.63 L/s

Target release rate: 6.44 L/s

Project #160401782, 283 & 285 McLeod Street Modified Rational Method Calculations for Storage

100 yr Intensity City of Ottawa	$I = a/(t + b)^c$	a =	1735.688	t (min)	I (mm/hr)
		b =	6.014	10	178.56
		c =	0.820	20	119.95
				30	91.87
			40	75.15	
			50	63.95	
			60	55.89	
			70	49.79	
			80	44.99	
			90	41.11	
			100	37.90	
			110	35.20	
			120	32.89	

100 YEAR Predevelopment Target Release from Portion of Site

Subdrainage Area: Predevelopment Tributary Area to Outlet
 Area (ha): 0.0628
 C: 0.40

Target stormwater release rate determined using a C of 0.4 in a 2-year event and subtracting the peak sanitary flow rate (as per preconsultation with the City).

Target release rate: 6.44 L/s

2 YEAR Modified Rational Method for Entire Site

Subdrainage Area: DRAIN-5 Uncontrolled - Non-Tributary
 Area (ha): 0.003
 C: 0.9

tc (min)	I (2 yr) (mm/hr)	Qactual (L/s)	Qrelease (L/s)	Qstored (L/s)	Vstored (m ³)
10	76.81	0.58	0.58		
20	52.03	0.39	0.39		
30	40.04	0.30	0.30		
40	32.86	0.25	0.25		
50	28.04	0.21	0.21		
60	24.56	0.18	0.18		
70	21.91	0.16	0.16		
80	19.83	0.15	0.15		
90	18.14	0.14	0.14		
100	16.75	0.13	0.13		
110	15.57	0.12	0.12		
120	14.56	0.11	0.11		

100 YEAR Modified Rational Method for Entire Site

Subdrainage Area: DRAIN-5 Uncontrolled - Non-Tributary
 Area (ha): 0.003
 C: 1.00

tc (min)	I (100 yr) (mm/hr)	Qactual (L/s)	Qrelease (L/s)	Qstored (L/s)	Vstored (m ³)
10	178.56	1.49	1.49		
20	119.95	1.00	1.00		
30	91.87	0.77	0.77		
40	75.15	0.63	0.63		
50	63.95	0.53	0.53		
60	55.89	0.47	0.47		
70	49.79	0.42	0.42		
80	44.99	0.38	0.38		
90	41.11	0.34	0.34		
100	37.90	0.32	0.32		
110	35.20	0.29	0.29		
120	32.89	0.27	0.27		

Subdrainage Area: DRAIN-4 Uncontrolled - Non-Tributary
 Area (ha): 0.001
 C: 0.90

tc (min)	I (2 yr) (mm/hr)	Qactual (L/s)	Qrelease (L/s)	Qstored (L/s)	Vstored (m ³)
10	76.81	0.19	0.19		
20	52.03	0.13	0.13		
30	40.04	0.10	0.10		
40	32.86	0.08	0.08		
50	28.04	0.07	0.07		
60	24.56	0.06	0.06		
70	21.91	0.05	0.05		
80	19.83	0.05	0.05		
90	18.14	0.05	0.05		
100	16.75	0.04	0.04		
110	15.57	0.04	0.04		
120	14.56	0.04	0.04		

Subdrainage Area: DRAIN-4 Uncontrolled - Non-Tributary
 Area (ha): 0.001
 C: 1.00

tc (min)	I (100 yr) (mm/hr)	Qactual (L/s)	Qrelease (L/s)	Qstored (L/s)	Vstored (m ³)
10	178.56	0.50	0.50		
20	119.95	0.33	0.33		
30	91.87	0.26	0.26		
40	75.15	0.21	0.21		
50	63.95	0.18	0.18		
60	55.89	0.16	0.16		
70	49.79	0.14	0.14		
80	44.99	0.13	0.13		
90	41.11	0.11	0.11		
100	37.90	0.11	0.11		
110	35.20	0.10	0.10		
120	32.89	0.09	0.09		

Subdrainage Area: DRAIN-3 Uncontrolled - Non-Tributary
 Area (ha): 0.001
 C: 0.90

tc (min)	I (2 yr) (mm/hr)	Qactual (L/s)	Qrelease (L/s)	Qstored (L/s)	Vstored (m ³)
10	76.81	0.19	0.19		
20	52.03	0.13	0.13		
30	40.04	0.10	0.10		
40	32.86	0.08	0.08		
50	28.04	0.07	0.07		
60	24.56	0.06	0.06		
70	21.91	0.05	0.05		
80	19.83	0.05	0.05		
90	18.14	0.05	0.05		
100	16.75	0.04	0.04		
110	15.57	0.04	0.04		
120	14.56	0.04	0.04		

Subdrainage Area: DRAIN-3 Uncontrolled - Non-Tributary
 Area (ha): 0.001
 C: 1.00

tc (min)	I (100 yr) (mm/hr)	Qactual (L/s)	Qrelease (L/s)	Qstored (L/s)	Vstored (m ³)
10	178.56	0.50	0.50		
20	119.95	0.33	0.33		
30	91.87	0.26	0.26		
40	75.15	0.21	0.21		
50	63.95	0.18	0.18		
60	55.89	0.16	0.16		
70	49.79	0.14	0.14		
80	44.99	0.13	0.13		
90	41.11	0.11	0.11		
100	37.90	0.11	0.11		
110	35.20	0.10	0.10		
120	32.89	0.09	0.09		

Stormwater Management Calculations

Project #160401782, 283 & 285 McLeod Street
 Modified Rational Method Calculations for Storage

Subdrainage Area: DRAIN-2 Uncontrolled - Non-Tributary
 Area (ha): 0.001
 C: 0.90

tc (min)	I (2 yr) (mm/hr)	Qactual (L/s)	Qrelease (L/s)	Qstored (L/s)	Vstored (m ³)
10	76.81	0.19	0.19		
20	52.03	0.13	0.13		
30	40.04	0.10	0.10		
40	32.86	0.08	0.08		
50	28.04	0.07	0.07		
60	24.56	0.06	0.06		
70	21.91	0.05	0.05		
80	19.83	0.05	0.05		
90	18.14	0.05	0.05		
100	16.75	0.04	0.04		
110	15.57	0.04	0.04		
120	14.56	0.04	0.04		

Project #160401782, 283 & 285 McLeod Street
 Modified Rational Method Calculations for Storage

Subdrainage Area: DRAIN-2 Uncontrolled - Non-Tributary
 Area (ha): 0.001
 C: 1.00

tc (min)	I (100 yr) (mm/hr)	Qactual (L/s)	Qrelease (L/s)	Qstored (L/s)	Vstored (m ³)
10	178.56	0.50	0.50		
20	119.95	0.33	0.33		
30	91.87	0.26	0.26		
40	75.15	0.21	0.21		
50	63.95	0.18	0.18		
60	55.89	0.16	0.16		
70	49.79	0.14	0.14		
80	44.99	0.13	0.13		
90	41.11	0.11	0.11		
100	37.90	0.11	0.11		
110	35.20	0.10	0.10		
120	32.89	0.09	0.09		

Subdrainage Area: ROOF-1 Roof
 Area (ha): 0.035 Maximum Storage Depth: 150 mm
 C: 0.90

tc (min)	I (2 yr) (mm/hr)	Qactual (L/s)	Qrelease (L/s)	Qstored (L/s)	Vstored (m ³)	Depth (mm)
10	76.81	6.73	1.58	5.15	3.09	89.0
20	52.03	4.56	1.58	2.98	3.58	94.0
30	40.04	3.51	1.58	1.93	3.47	93.0
40	32.86	2.88	1.58	1.30	3.12	89.3
50	28.04	2.46	1.58	0.88	2.64	84.2
60	24.56	2.15	1.58	0.57	2.06	78.3
70	21.91	1.92	1.58	0.34	1.44	68.6
80	19.83	1.74	1.58	0.16	0.77	55.0
90	18.14	1.59	1.58	0.01	0.07	25.1
100	16.75	1.47	1.46	0.01	0.06	23.1
110	15.57	1.36	1.35	0.01	0.06	21.5
120	14.56	1.28	1.27	0.01	0.05	20.1

Storage: Roof Storage

Depth (mm)	Head (m)	Discharge (L/s)	Vreq (cu. m)	Vavail (cu. m)	Discharge Check
94.03	0.09	1.58	3.58	14.00	0.00

2-year Water Level

Subdrainage Area: ROOF-1 Roof
 Area (ha): 0.035 Maximum Storage Depth: 150 mm
 C: 1.00

tc (min)	I (100 yr) (mm/hr)	Qactual (L/s)	Qrelease (L/s)	Qstored (L/s)	Vstored (m ³)	Depth (mm)
10	178.56	17.37	1.58	15.80	9.48	130.8
20	119.95	11.67	1.58	10.09	12.11	142.0
30	91.87	8.94	1.58	7.36	13.25	146.8
40	75.15	7.31	1.58	5.73	13.76	149.0
50	63.95	6.22	1.58	4.65	13.94	149.7
60	55.89	5.44	1.58	3.86	13.90	149.6
70	49.79	4.84	1.58	3.27	13.72	148.8
80	44.99	4.38	1.58	2.80	13.44	147.6
90	41.11	4.00	1.58	2.42	13.08	146.1
100	37.90	3.69	1.58	2.11	12.67	144.3
110	35.20	3.43	1.58	1.85	12.20	142.4
120	32.89	3.20	1.58	1.62	11.69	140.2

Storage: Roof Storage

Depth (mm)	Head (m)	Discharge (L/s)	Vreq (cu. m)	Vavail (cu. m)	Discharge Check
149.73	0.15	1.58	13.94	14.00	0.00

100-year Water Level

Subdrainage Area: DRAIN-1 Uncontrolled - Non-Tributary
 Area (ha): 0.003
 C: 0.90

tc (min)	I (2 yr) (mm/hr)	Qactual (L/s)	Qrelease (L/s)	Qstored (L/s)	Vstored (m ³)
10	76.81	0.58	0.58		
20	52.03	0.39	0.39		
30	40.04	0.30	0.30		
40	32.86	0.25	0.25		
50	28.04	0.21	0.21		
60	24.56	0.18	0.18		
70	21.91	0.16	0.16		
80	19.83	0.15	0.15		
90	18.14	0.14	0.14		
100	16.75	0.13	0.13		
110	15.57	0.12	0.12		
120	14.56	0.11	0.11		

Subdrainage Area: DRAIN-1 Uncontrolled - Non-Tributary
 Area (ha): 0.003
 C: 1.00

tc (min)	I (100 yr) (mm/hr)	Qactual (L/s)	Qrelease (L/s)	Qstored (L/s)	Vstored (m ³)
10	178.56	1.49	1.49		
20	119.95	1.00	1.00		
30	91.87	0.77	0.77		
40	75.15	0.63	0.63		
50	63.95	0.53	0.53		
60	55.89	0.47	0.47		
70	49.79	0.42	0.42		
80	44.99	0.38	0.38		
90	41.11	0.34	0.34		
100	37.90	0.32	0.32		
110	35.20	0.29	0.29		
120	32.89	0.27	0.27		

Subdrainage Area: UNC-2 Uncontrolled - Non-Tributary
 Area (ha): 0.012
 C: 0.88

tc (min)	I (2 yr) (mm/hr)	Qactual (L/s)	Qrelease (L/s)	Qstored (L/s)	Vstored (m ³)
10	76.81	2.25	2.25		
20	52.03	1.53	1.53		
30	40.04	1.18	1.18		
40	32.86	0.96	0.96		
50	28.04	0.82	0.82		
60	24.56	0.72	0.72		
70	21.91	0.64	0.64		
80	19.83	0.58	0.58		
90	18.14	0.53	0.53		
100	16.75	0.49	0.49		
110	15.57	0.46	0.46		
120	14.56	0.43	0.43		

Subdrainage Area: UNC-2 Uncontrolled - Non-Tributary
 Area (ha): 0.012
 C: 1.00

tc (min)	I (100 yr) (mm/hr)	Qactual (L/s)	Qrelease (L/s)	Qstored (L/s)	Vstored (m ³)
10	178.56	5.96	5.96		
20	119.95	4.00	4.00		
30	91.87	3.06	3.06		
40	75.15	2.51	2.51		
50	63.95	2.13	2.13		
60	55.89	1.86	1.86		
70	49.79	1.66	1.66		
80	44.99	1.50	1.50		
90	41.11	1.37	1.37		
100	37.90	1.26	1.26		
110	35.20	1.17	1.17		
120	32.89	1.10	1.10		

Subdrainage Area: UNC-1 Uncontrolled - Non-Tributary
 Area (ha): 0.027
 C: 0.85

tc (min)	I (2 yr) (mm/hr)	Qactual (L/s)	Qrelease (L/s)	Qstored (L/s)	Vstored (m ³)
10	76.81	4.87	4.87		
20	52.03	3.30	3.30		
30	40.04	2.54	2.54		
40	32.86	2.08	2.08		
50	28.04	1.78	1.78		
60	24.56	1.56	1.56		
70	21.91	1.39	1.39		
80	19.83	1.26	1.26		
90	18.14	1.15	1.15		
100	16.75	1.06	1.06		
110	15.57	0.99	0.99		
120	14.56	0.92	0.92		

Subdrainage Area: UNC-1 Uncontrolled - Non-Tributary
 Area (ha): 0.027
 C: 1.00

tc (min)	I (100 yr) (mm/hr)	Qactual (L/s)	Qrelease (L/s)	Qstored (L/s)	Vstored (m ³)
10	178.56	13.32	13.32		
20	119.95	8.95	8.95		
30	91.87	6.85	6.85		
40	75.15	5.61	5.61		
50	63.95	4.77	4.77		
60	55.89	4.17	4.17		
70	49.79	3.71	3.71		
80	44.99	3.36	3.36		
90	41.11	3.07	3.07		
100	37.90	2.83	2.83		
110	35.20	2.63	2.63		
120	32.89	2.45	2.45		

Stormwater Management Calculations

**Project #160401782, 283 & 285 McLeod Street
Modified Rational Method Calculations for Storage**

SUMMARY TO OUTLET		Vrequired	Vavailable*	
Tributary Area	0.044 ha			
2yr Flow to STM Service Lateral (Controlled)	1.58 L/s	3.58	14.00 m ³	OK
2yr Flow to STM Service Lateral (Uncontrolled)	1.73 L/s			
Total 2yr Flow to STM Service Lateral	3.31 L/s			
Non-Tributary Area	0.039 ha			
2yr Surface Flow Uncontrolled to Mcleod ROW	7.13 L/s			
Total Area	0.083 ha			
Total 2yr Release Rate from Site	10.43 L/s			
Target Release Rate to McLeod Combined Sewer	6.44 L/s			

**Project #160401782, 283 & 285 McLeod Street
Modified Rational Method Calculations for Storage**

SUMMARY TO OUTLET		Vrequired	Vavailable*	
Tributary Area	0.044 ha			
100yr Flow to STM Service Lateral (Controlled)	1.58 L/s	13.94	14.00 m ³	OK
100yr Flow to Storm Service Lateral (Uncontrolled)	4.47 L/s			
Total 100yr Flow to STM Service Lateral	6.04 L/s			
Non-Tributary Area	0.039 ha			
100yr Surface Flow Uncontrolled to Mcleod ROW	19.28 L/s			
Total Area	0.083 ha			
Total 100yr Release Rate from Site	25.32 L/s			
Target Release Rate to McLeod Combined Sewer	6.44 L/s			

D.2 PREDEVELOPMENT TIME OF CONCENTRATION CALCULATION



Federal Aviation Administration (FAA) (1970) Pre-Development Time of Concentration Calculation

Project: 283 - 285 McLeod Street

Stantec Project Number: 160401771

Last updated on: 2021-08-10

Federal Aviation Administration (1970)	$t_c = 1.8(1.1 - C)L^{0.50}/S^{0.333}$ [min]	Developed from air field drainage data assembled by the US Corps of Engineers; method is intended for use on airfield drainage problems, but has been used frequently for overland flow in urban basins
C =	rational method runoff coefficient	
L =	length of overland flow, ft	
S =	surface slope, ft/ft	

For the existing site in the pre-development condition:

$t_c =$ 3.41 minutes

Variable	Value	Unit	Notes
C	0.85	unitless	Represents existing condition of the site
L	112	ft	Measured from the North edge of site (rear end) to South edge (entrance) of site along prevailing slope.
S	2.73	%	

Since the calculated time of concentration is less than 10 minutes, a 10 minute time of concentration will be used to determine the stormwater target release rate.

D.3 WATTS ADJUSTABLE ACCUTROL WEIR DETAIL (2016)





Adjustable Accutrol Weir
 Tag: _____

**Adjustable Flow Control
 for Roof Drains**

ADJUSTABLE ACCUTROL (for Large Sump Roof Drains only)

For more flexibility in controlling flow with heads deeper than 2", Watts Drainage offers the Adjustable Accutrol. The Adjustable Accutrol Weir is designed with a single parabolic opening that can be covered to restrict flow above 2" of head to less than 5 gpm per inch, up to 6" of head. To adjust the flow rate for depths over 2" of head, set the slot in the adjustable upper cone according to the flow rate required. Refer to Table 1 below.
 Note: Flow rates are directly proportional to the amount of weir opening that is exposed.

EXAMPLE:

For example, if the adjustable upper cone is set to cover 1/2 of the weir opening, flow rates above 2" of head will be restricted to 2-1/2 gpm per inch of head.

Therefore, at 3" of head, the flow rate through the Accutrol Weir that has 1/2 the slot exposed will be:
 [5 gpm (per inch of head) x 2 inches of head] + 2-1/2 gpm (for the third inch of head) = 12-1/2 gpm.

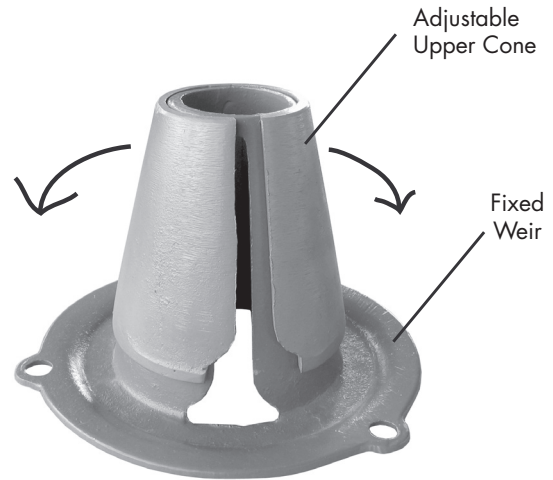
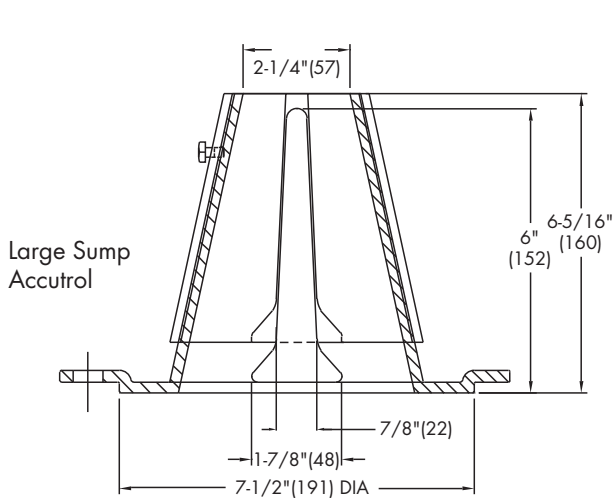

1/2 Weir Opening Exposed Shown Above

TABLE 1. Adjustable Accutrol Flow Rate Settings

Weir Opening Exposed	1"	2"	3"	4"	5"	6"
	Flow Rate (gallons per minute)					
Fully Exposed	5	10	15	20	25	30
3/4	5	10	13.75	17.5	21.25	25
1/2	5	10	12.5	15	17.5	20
1/4	5	10	11.25	12.5	13.75	15
Closed	5	5	5	5	5	5

Job Name _____
 Job Location _____
 Engineer _____

Contractor _____
 Contractor's P.O. No. _____
 Representative _____

Watts product specifications in U.S. customary units and metric are approximate and are provided for reference only. For precise measurements, please contact Watts Technical Service. Watts reserves the right to change or modify product design, construction, specifications, or materials without prior notice and without incurring any obligation to make such changes and modifications on Watts products previously or subsequently sold.

USA: Tel: (800) 338-2581 • Fax: (828) 248-3929 • Watts.com
 Canada: Tel: (905) 332-4090 • Fax: (905) 332-7068 • Watts.ca
 Latin America: Tel: (52) 81-1001-8600 • Fax: (52) 81-8000-7091 • Watts.com



D.4 CORRESPONDENCE WITH THE CITY OF OTTAWA STAFF - STORMWATER MANAGEMENT APPROACH (2022.12.08)



Wu, Michael

From: Wessel, Shawn <shawn.wessel@ottawa.ca>
Sent: Thursday, 8 December, 2022 11:20
To: Gladish, Alyssa
Cc: Wu, Michael; Cody, Neal; Burton, David; 'James Colizza'; McCreight, Andrew
Subject: RE: 283-285 McLeod Street Stormwater Management Requirements
Attachments: Paterson Group Report PG5489-1 Rev. 1 dated July 22, 2021.pdf; 221110_283+285 MCLEOD_FOOTING ELEVATIONS.pdf; 221102_283+285 MCLEOD_BASEMENT_FLOOR_PLAN.pdf

Good afternoon, Alyssa and thank you for your email.

Considering the following:

1. Peak dry weather flows from the adjacent areas, the HGL is 66.28 m, provide adequate FB for the McLeod system in front of 283-285 McLeod St.
Furthermore, another 1.58 l/s release rate from this site to the City system will not have a significant impact on the HGL, whereas this site is not expected to endure a system surcharge (backup), although we do however recommend a BWV be installed at the property as a second line of defense to minimize basement flooding.
2. Matching post to predevelopment, with mostly controlling on the site at roof and a small amount of uncontrolled flows directed to nearby CBs in ROW.
3. The release rate of 1.58 l/s directed to the City sewer system. Attached drawing has indicated that roof top storage is being controlled by roof drains.
4. Geotech Report speaks to using a mud slab on exposed clay during excavation process to protect subgrade and the use of either a raft or pile foundation system due to subgrade soil type, which does not permit a cistern in this case.

We are fine with what is being proposed, with the exception to the following item that we wanted to note and prior to detailed design review:

- A. As per SDG, trench drains typically drain to sanitary, whereas the City infrastructure fronting this site is a combined sewer and therefore a separate lateral for trench drain to the combined sewer is required. Refer to Standard Detail Drawing S17. We also suggest pumping with a backup pump and power and in either case, require a plan for emergency overflow due to connection to combined sewer system and opportunity for surcharge flows to enter garage at this location.

If you require additional information or clarification, please do not hesitate to contact me anytime.

Thank you

Regards,

Shawn Wessel, A.Sc.T.,rcji

Pronouns: he/him | Pronom: il

Project Manager - Infrastructure Approvals

Gestionnaire de projet – Approbation des demandes d’infrastructures

Development Review Central Branch | Direction de l’examen des projets d’aménagement, Centrale
Planning, Real Estate and Economic Development Department | Direction générale de la planification des biens immobiliers et du développement économique

City of Ottawa | Ville d'Ottawa

110 Laurier Ave. W. | 110, avenue Laurier Ouest, Ottawa ON K1P 1J1

(613) 580 2424 Ext. | Poste 33017

Int. Mail Code | Code de Courrier Interne 01-14

shawn.wessel@ottawa.ca

 Please consider the environment before printing this email

*****Please also note that, while my work hours may be affected by the current situation and am working from home, I still have access to email, video conferencing and telephone. Feel free to schedule video conferences and/or telephone calls, as necessary.*****

From: Gladish, Alyssa <Alyssa.Gladish@stantec.com>

Sent: December 07, 2022 1:45 PM

To: Wessel, Shawn <shawn.wessel@ottawa.ca>

Cc: Wu, Michael <Michael.Wu@stantec.com>; Cody, Neal <Neal.Cody@stantec.com>; Burton, David <David.Burton@stantec.com>; 'James Colizza' <JC@colizzabruni.com>; McCreight, Andrew <Andrew.McCreight@ottawa.ca>

Subject: RE: 283-285 McLeod Street Stormwater Management Requirements

CAUTION: This email originated from an External Sender. Please do not click links or open attachments unless you recognize the source.

ATTENTION : Ce courriel provient d’un expéditeur externe. Ne cliquez sur aucun lien et n’ouvrez pas de pièce jointe, excepté si vous connaissez l’expéditeur.

Hello Shawn,

I have attached the geotechnical report, elevation plans, and basement floor plan for your review. I do not believe the geotechnical report speaks to the cistern specifically.

This is not my area of expertise, but it is my understanding that there are engineering and safety concerns with siting the cistern below the raft slab due to the fundamental principles of the raft slab design. Providing the cistern’s maintenance/monitoring access hole through to the 3’ slab of concrete introduces additional concerns.

We will review Section 5.7.6 of the City SDG (with latest ISTB updates) regarding the treatment of the reverse-sloped ramp.

We are hoping to have this ZBA/OPA resubmission prepared as soon as possible – is there any way our team might be able to have a meeting with yourself, and other pertinent City staff (perhaps someone from the modelling group), to collectively work through these ideas?

Thank you,
Alyssa

Alyssa Gladish E.I.T.
Project Manager, Community Development

Direct: 780 917-8567
Mobile: 587 721-1241
Alyssa.Gladish@stantec.com

Stantec
300-1331 Clyde Avenue
Ottawa ON K2C 3G4



The content of this email is the confidential property of Stantec and should not be copied, modified, retransmitted, or used for any purpose except with Stantec's written authorization. If you are not the intended recipient, please delete all copies and notify us immediately.

From: Wessel, Shawn <shawn.wessel@ottawa.ca>
Sent: Friday, December 2, 2022 8:39 PM
To: Gladish, Alyssa <Alyssa.Gladish@stantec.com>
Cc: Wu, Michael <Michael.Wu@stantec.com>; Cody, Neal <Neal.Cody@stantec.com>; Burton, David <David.Burton@stantec.com>; 'James Colizza' <JC@colizzabruni.com>; McCreight, Andrew <Andrew.McCreight@ottawa.ca>
Subject: RE: 283-285 McLeod Street Stormwater Management Requirements

Hello again Alyssa

May I request the Geotechnical Report and the floor and foundation plans for our review so as to understand why the cistern is not a viable option.

I realize that this is a small site, although we are dealing with a combined sewer system which may be near capacity and I would like to see some documentation that speaks to these issues.

I have also consulted our modeling group to better understand how this proposal may benefit or affect our system, albeit being close to a nearby outlet, and taking into account previous files that permitted a deviation from our required SWM criteria.

I did note that the reverse sloped ramp to the garage is considered a depressed driveway and want to refer you to Section 5.7.6 of the City SDG (with latest ISTB updates).

If you require additional information or clarification, please do not hesitate to contact me anytime.

Thank you

Regards,

Shawn Wessel, A.Sc.T.,rcji
Project Manager - Infrastructure Approvals
Gestionnaire de projet – Approbation des demandes d’infrastructures

Development Review Central Branch | Direction de l’examen des projets d’aménagement, Centrale
Planning, Real Estate and Economic Development Department | Direction générale de la planification des biens immobiliers et du développement économique
City of Ottawa | Ville d'Ottawa
110 Laurier Ave. W. | 110, avenue Laurier Ouest, Ottawa ON K1P 1J1
(613) 580 2424 Ext. | Poste 33017
Int. Mail Code | Code de Courrier Interne 01-14
shawn.wessel@ottawa.ca

 Please consider the environment before printing this email

*****Please also note that, while my work hours may be affected by the current situation and am working from home, I still have access to email, video conferencing and telephone. Feel free to schedule video conferences and/or telephone calls, as necessary.*****

From: Gladish, Alyssa <Alyssa.Gladish@stantec.com>
Sent: November 30, 2022 6:50 PM
To: Wessel, Shawn <shawn.wessel@ottawa.ca>
Cc: Wu, Michael <Michael.Wu@stantec.com>; Cody, Neal <Neal.Cody@stantec.com>; Burton, David <David.Burton@stantec.com>; 'James Colizza' <JC@colizzabruni.com>
Subject: 283-285 McLeod Street Stormwater Management Requirements

CAUTION: This email originated from an External Sender. Please do not click links or open attachments unless you recognize the source.

ATTENTION : Ce courriel provient d’un expéditeur externe. Ne cliquez sur aucun lien et n’ouvrez pas de pièce jointe, excepté si vous connaissez l’expéditeur.

Good afternoon, Shawn:

I am looking to initiate some dialogue regarding the stormwater management requirements for 283-285 McLeod Street. Specifically, we would like to discuss the approach for the SWM Quantity Control.

It is our understanding through the pre-consultation notes that the following SWM criteria have been identified for this site:

- Time of concentration for the site is to be equal to or greater than 10 minutes
- Existing conditions are to be determined based on a rational method runoff coefficient of no greater than 0.4
- Storms up to and including the 100-year event are to be attenuated to the 2-year pre-development event

For the first submission, the SWM targets were met using rooftop storage with restricted release as well as a cistern (proposed below the basement slab) to be mechanically pumped at a restricted release rate.

During the development review process, Heritage Planning and Urban Design required many changes to the Site Plan to accommodate the streetscape and landscaping. The two front 3-storey portions of the building

were required to have peaked roofs to mimic individual houses. As a result, we lost about 30% of our available rooftop storage area.

As I mentioned in my last email, due to the complex foundation requirements and difficult soil conditions, it is no longer feasible to situate the cistern below the basement slab. This has left us with virtually no opportunities within the building footprint to situate the cistern. Other detention storage techniques were investigated, such as having an underground storage unit/pipe (providing approximately 14 m³ of storage) located directly underneath the ramp to the underground parking garage. Outflow from the underground storage pipe would be controlled by an appropriately sized ICD. Given there are concerns regarding the elevated hydraulic grade lines in the combined sewer, a cistern or storage pipe outlet could increase the risk of surcharging the sewer. In addition, underground storage (whether a tank or pipe) will require a manhole for monitoring and maintenance. The addition of a manhole cover within the driveway pavers does not benefit the visual appeal of the frontage and works against the directives from Heritage and Urban Planning for this site. Infiltration and LID stormwater management strategies were not considered for this site, as the challenging soil conditions do not recommend the addition of moisture to the subsurface. With the loss of roof storage area compounded with the underground cistern/pipe storage concerns, it is no longer feasible to reasonably meet the stringent stormwater quantity control criteria for this site.

This site has a total area of 0.082 ha, and the proposed building covers 0.048 ha (58.5 %).

The breakdown of the site surfacing is as follows:

- 0.033 ha (40.2 %) flat roof that is available for stormwater storage
- 0.023 ha (28.1 %) outdoor amenity spaces
- 0.015 ha (18.3 %) peaked roofs
- 0.011 ha (13.4 %) other landscaped areas

Since the site is less than 0.1ha in total area, and the roof storage area occupies most of the site, we would like to request **controlling only the roof storage area and allowing the remaining site area to flow uncontrolled** to the McLeod Street right of way.

The roof-only control approach has recently been recommended in pre-consultation minutes for many similar infill development sites in the city, where the site is less than 0.1 ha, and the roof storage area covers most of the site. Some examples include 138 Forward Avenue (D07-12-21-0237), 139 Parkdale Avenue (PC2021.0385), 1806 Scott Street, and 391 Dieppe Street, to name a few. In each case, roof-only control was permitted provided the uncontrolled areas were directed toward the right of way. In the proposed SWM approach for this site, the uncontrolled area can effectively be directed to the McLeod Street ROW to the south.

We believe this approach should be acceptable for this site for four key reasons:

1. Many changes that were required for Heritage and Urban design work against the site being able to fulfill all technical criteria. Since every effort has been made to accommodate and comply with the architectural and planning requirements, we are hoping the city will allow for some compromise regarding the stormwater management criteria.
2. The site is less than 0.1 ha, and the controlled roof area occupies the majority of the site.
3. The site is situated relatively close to the receiving waterbody of the major system (less than one kilometer from the canal). Getting stormwater to the receiving body as quickly as possible provides some benefits to the overall system, since it avoids compounding the upstream hydrograph peak. Hence, allowing a portion of the site to flow uncontrolled to the right of way may reduce peak burdens/demands on the combined municipal sewer.
4. The development of the property and the addition of roof storage provides a significant improvement compared to existing conditions. To support this claim, we have prepared an existing stormwater drainage plan for the site (see attached) to determine the existing runoff coefficient (C) value and the table below (Table 1) that compares pre-to-post development stormwater release rates. We found that

under existing conditions the runoff coefficient for the site is C=0.77. Using the rational method, we determined the pre-development stormwater release rates for the site are 12.88 L/s for the 2-year event and 30.74 L/s for the 100-year event.

In the attached preliminary stormwater management plan (SD-1) and preliminary MRM analysis, you will find that we have maximized the use of the rooftop storage by using five flow-controlled roof drains set to the closed position (minimal release rate). The remaining “at grade” site area will drain uncontrolled to the ROW. Depressed patios, entrances, and the sunken rear yard amenity space will require area drains and will need to be routed through the internal plumbing to the building stormwater service. We will ensure that the combined STM and SAN service lateral release rates do not exceed the 2-year pre-development rate (@C=0.4) to the combined sewer under all events up to and including the 100-year event.

Based on the characteristics of the subcatchments in the SD-1 plan we used the modified rational method to calculate the post-development release rates for the developed site to be 10.44 L/s for the 2-year event and 25.90 L/s for the 100-year event.

Seeing as the exceedance originates from the uncontrolled subcatchment areas (areas that can't readily be captured by onsite SWM infrastructure), the benefits to introducing additional SWM infrastructure would be negligible. It is our understanding that due to the proximity of the canal, there are benefits to getting the stormwater to the canal as soon as possible and avoid compounding the upstream hydrograph peak. The 13.02 L/s exceedance under the 100-year event should be considered acceptable. Please confirm if this SWM approach for quantity control is supported by the City of Ottawa. In other words, by controlling the roof area, the overall stormwater release rate is reduced by 23 % for the 2-year event and by 17 % for the 100-year event, compared to the existing (pre-development) conditions.

TABLE 1 - COMPARISON OF PRE-TO-POST DEVELOPMENT STORMWATER RELEASE RATES

	2-Year Peak Discharge				100-Year Peak Discharge			
	Pre-Dev. @ C=0.77	Post-Dev.	Difference		Pre-Dev. @ C=0.77	Post-Dev.	Difference	
	(L/s)	(L/s)	(L/s)	%	(L/s)	(L/s)	(L/s)	%
Uncontrolled – Surface	13.48	8.86	-4.02	-	31.34	24.32	-6.42	-
Controlled – Rooftop Storage	-	1.58	1.58	-	-	1.58	1.58	-
Total	13.48	10.44	-3.04	-23%	31.34	25.90	-5.44	-17%

We would like to proceed with the SWM approach for quantity control where only the roof storage area is controlled, and the remaining site area is allowed to flow uncontrolled to the McLeod Street right of way. **Please confirm if this SWM approach for quantity control can be supported by the City of Ottawa.**

If you have any questions or concerns, or if additional information is required, please do not hesitate to contact me, or I would be happy to setup a Teams meeting for further discussion.

Best regards,

Alyssa Gladish E.I.T.

Project Manager, Community Development

Direct: 780 917-8567

Mobile: 587 721-1241

Alyssa.Gladish@stantec.com

Stantec
300-1331 Clyde Avenue
Ottawa ON K2C 3G4



The content of this email is the confidential property of Stantec and should not be copied, modified, retransmitted, or used for any purpose except with Stantec's written authorization. If you are not the intended recipient, please delete all copies and notify us immediately.

This e-mail originates from the City of Ottawa e-mail system. Any distribution, use or copying of this e-mail or the information it contains by other than the intended recipient(s) is unauthorized. Thank you.

Le présent courriel a été expédié par le système de courriels de la Ville d'Ottawa. Toute distribution, utilisation ou reproduction du courriel ou des renseignements qui s'y trouvent par une personne autre que son destinataire prévu est interdite. Je vous remercie de votre collaboration.

Caution: This email originated from outside of Stantec. Please take extra precaution.

Attention: Ce courriel provient de l'extérieur de Stantec. Veuillez prendre des précautions supplémentaires.

Atención: Este correo electrónico proviene de fuera de Stantec. Por favor, tome precauciones adicionales.

This e-mail originates from the City of Ottawa e-mail system. Any distribution, use or copying of this e-mail or the information it contains by other than the intended recipient(s) is unauthorized. Thank you.

Le présent courriel a été expédié par le système de courriels de la Ville d'Ottawa. Toute distribution, utilisation ou reproduction du courriel ou des renseignements qui s'y trouvent par une personne autre que son destinataire prévu est interdite. Je vous remercie de votre collaboration.

Caution: This email originated from outside of Stantec. Please take extra precaution.

Attention: Ce courriel provient de l'extérieur de Stantec. Veuillez prendre des précautions supplémentaires.

Atención: Este correo electrónico proviene de fuera de Stantec. Por favor, tome precauciones adicionales.

Appendix E **EXTERNAL REPORT**

E.1 **GEOTECHNICAL INVESTIGATION, REV.01 BY PATERSON GROUP INC (JULY 2021)**



Geotechnical
Engineering

Environmental
Engineering

Hydrogeology

Geological
Engineering

Materials Testing

Building Science

Noise & Vibration Studies

Geotechnical Investigation
Proposed Multi-Storey Building
283-285 McLeod Street
Ottawa, Ontario

Prepared For

Zyer Developments

Paterson Group Inc.
Consulting Engineers
154 Colonnade Road
Ottawa (Nepean), Ontario
Canada K2E 7J5

Tel: (613) 226-7381
Fax: (613) 226-6344
www.patersongroup.ca

July 22, 2021

Report PG5489-1
Revision 1

Table of Contents

	Page
1.0 Introduction	1
2.0 Proposed Development	1
3.0 Method of Investigation	
3.1 Field Investigation	2
3.2 Field Survey	3
3.3 Laboratory Testing	3
3.4 Analytical Testing	3
4.0 Observations	
4.1 Surface Conditions	4
4.2 Subsurface Profile	4
4.3 Groundwater	5
5.0 Discussion	
5.1 Geotechnical Assessment	6
5.2 Site Grading and Preparation	6
5.3 Foundation Design	8
5.4 Design for Earthquakes	11
5.5 Basement Floor Slab	11
5.6 Basement Wall	11
5.7 Pavement Structure	13
6.0 Design and Construction Precautions	
6.1 Foundation Drainage and Backfill	14
6.2 Protection of Footings Against Frost Action	15
6.3 Excavation Side Slopes	15
6.4 Pipe Bedding and Backfill	17
6.5 Groundwater Control	18
6.6 Winter Construction	19
6.7 Corrosion Potential and Sulphate	19
7.0 Recommendations	20
8.0 Statement of Limitations	21

Appendices

- Appendix 1** Soil Profile and Test Data Sheets
 Symbols and Terms
 Analytical Testing Results
- Appendix 2** Figure 1 - Key Plan
 Drawing PG5489-1 - Test Hole Location Plan

1.0 Introduction

Paterson Group (Paterson) was commissioned by Zyer Developments to conduct a geotechnical investigation for the proposed multi-storey building to be located at 283-285 McLeod Street in the City of Ottawa, Ontario (refer to Figure 1 - Key Plan in Appendix 2 of this report).

The objectives of the geotechnical investigation were to:

- ❑ Determine the subsoil and groundwater conditions at this site by means of boreholes.
- ❑ Provide geotechnical recommendations for the design of the proposed development including construction considerations which may affect the design.

The following report has been prepared specifically and solely for the aforementioned project which is described herein. It contains our findings and includes geotechnical recommendations pertaining to the design and construction of the subject development as they are understood at the time of writing this report.

2.0 Proposed Development

Based on available drawings, it is understood that the existing residential structure located in the southeast corner of the site will be demolished, while the existing residential structure located within the southwest corner of the subject site will remain. A new, multi-storey building with 1 level of underground parking will then be constructed which will extend over the existing building to remain.

Associated access lanes, walkways and landscaped areas are also anticipated as part of the proposed development. It is further understood that the proposed development will be municipally serviced.

3.0 Method of Investigation

3.1 Field Investigation

Field Program

The field program for the geotechnical investigation was carried out on September 4, 2020 and consisted of 3 boreholes advanced to a maximum depth of 11.3 m. The borehole locations were distributed in a manner to provide general coverage of the subject site. The approximate locations of the boreholes are shown on Drawing PG5489-1 - Test Hole Location Plan included in Appendix 2.

The boreholes were advanced using a truck-mounted auger drill rig operated by a two-person crew. All fieldwork was conducted under the full-time supervision of our personnel under the direction of a senior engineer. The drilling procedure consisted of augering to the required depths at the selected locations, sampling and testing the overburden.

Sampling and In Situ Testing

Soil samples were collected from the boreholes using two different techniques, namely, sampled directly from the auger flights (AU) or collected using a 50 mm diameter split-spoon (SS) sampler. All samples were visually inspected and initially classified on site and subsequently placed in sealed plastic bags. All samples were transported to our laboratory for further examination and classification. The depths at which the auger and split spoon samples were recovered from the boreholes are shown as AU and SS, respectively, on the Soil Profile and Test Data sheets presented in Appendix 1.

A Standard Penetration Test (SPT) was conducted in conjunction with the recovery of the split spoon samples. The SPT results are recorded as "N" values on the Soil Profile and Test Data sheets. The "N" value is the number of blows required to drive the split spoon sampler 300 mm into the soil after a 150 mm initial penetration using a 63.5 kg hammer falling from a height of 760 mm.

Undrained shear strength testing, using a vane apparatus, was carried out at regular intervals of depth in cohesive soils.

The overburden thickness was evaluated by a dynamic cone penetration test (DCPT) completed at BH 3. The DCPT consists of driving a steel drill rod, equipped with a 50 mm diameter cone at the tip, using a 63.5 kg hammer falling from a height of 760 mm. The number of blows required to drive the cone into the soil is recorded for each 300 mm increment.

The subsurface conditions observed in the test holes were recorded in detail in the field. The soil profiles are presented on the Soil Profile and Test Data sheets in Appendix 1 of this report.

3.2 Field Survey

The test hole locations were selected by Paterson to provide general coverage of the subject site taking into consideration the existing site features and underground utilities. The test hole locations and ground surface elevation at each test hole location were surveyed by Paterson and are referenced to a geodetic datum. The location of the test holes and ground surface elevation at each test hole location are presented on Drawing PG5489-1 - Test Hole Location Plan in Appendix 2.

3.3 Laboratory Testing

Soil samples were recovered from the subject site and visually examined in our laboratory to review the results of the field logging.

3.4 Analytical Testing

One (1) soil sample was submitted for analytical testing to assess the potential for exposed ferrous metals and the potential of sulphate attacks against subsurface concrete structures. The sample was analyzed to determine its concentration of sulphate and chloride along with its resistivity and pH. The laboratory test results are shown in Appendix 1 and the results are discussed in Subsection 6.7.

4.0 Observations

4.1 Surface Conditions

The subject site consists of 2 contiguous properties, 285 and 283 McLeod Street, which border each other to the east and west, respectively. The site is bordered by a commercial property to the north, residential properties to the east and west, and McLeod Street to the south.

The southern half of the subject site is currently occupied by a 2 storey residential structure at 283 McLeod Street and a 2 storey commercial structure at 285 McLeod Street. The northern half of the property is currently occupied by an asphalt paved parking lot. The ground surface across the site is relatively level at approximate geodetic elevation 71 m.

4.2 Subsurface Profile

Overburden

Generally, the subsurface profile at the test hole locations consists of an approximate 50 to 100 mm thickness of asphalt underlain by fill which extends to approximate depths of 2.3 to 3.1 m below the existing ground surface. The fill was generally observed to consist of either a brown silty sand with gravel and brick or a brown silty clay.

A stiff grey silty clay deposit was observed underlying the fill material in boreholes BH 1 and BH 3. The silty clay in borehole BH 2 was observed to transition from a very stiff brown silty clay crust to a stiff grey silty clay at a depth of 3.8 m below the existing ground surface.

Refusal of the DCPT was encountered at an approximate depth of 28.2 m below the existing ground surface.

Bedrock

Based on available geological mapping, the bedrock at the subject site consists of shale of the Billings formation with a drift thickness of 25 to 50 m.

4.3 Groundwater

Groundwater levels were measured in the standpipes on April 9, 2020. The observed groundwater levels are summarized in Table 1.

Table 1 - Summary of Groundwater Level Readings				
Test Hole Number	Ground Surface Elevation (m)	Groundwater Depth (m)	Groundwater Elevation (m)	Recording Date
BH 1	71.04	7.70	63.34	September 11, 2020
BH 2	71.48	10.40	61.08	September 11, 2020
BH 3	71.46	Blocked and Dry	-	September 11, 2020
Note: - The ground surface elevations at the borehole locations are referenced to a geodetic datum.				

The recorded groundwater levels are noted on the applicable Soil Profile and Test Data sheet presented in Appendix 1. It should be noted that groundwater levels are subject to seasonal fluctuations. Therefore, the groundwater level could vary at the time of construction.

5.0 Discussion

5.1 Geotechnical Assessment

From a geotechnical perspective, the subject site is considered suitable for the proposed development. It is recommended that the proposed multi-storey building be founded on one of the following:

- ❑ A raft foundation bearing on an undisturbed, stiff silty clay bearing surface, or
- ❑ End-bearing piles extending to the bedrock.

Conventional spread footing may also be utilized to provide foundation support for isolated exterior columns and auxiliary structures.

Due to the presence of a deep silty clay deposit, a permissible grade raise restriction is required for the subject site.

The above and other considerations are discussed in the following paragraphs.

5.2 Site Grading and Preparation

Stripping Depth

Topsoil and fill, such as those containing organic or deleterious materials, should be stripped from under any building, paved areas, pipe bedding and other settlement sensitive structures.

Existing foundation walls and other construction debris should be entirely removed from within the building perimeter. Under paved areas, existing construction remnants, such as foundation walls, should be excavated to a minimum of 1 m below final grade.

Protection of Subgrade (Raft Foundation)

Since the subgrade material will consist of a silty clay deposit, it is recommended that a minimum 75 mm thick lean concrete mud slab be placed on the undisturbed silty clay subgrade shortly after the completion of the excavation. The main purpose of the mudslab is to reduce the risk of disturbance of the subgrade under the traffic of workers and equipment.

The final excavation to the raft bearing surface level and the placing of the mud slab should be done in smaller sections to avoid exposing large areas of the silty clay to potential disturbance due to drying.

Compacted Granular Fill Working Platform (Pile Foundation)

Should the proposed building be supported on a driven pile foundation, the use of heavy equipment would be required to install the piles (i.e. pile driving crane). It is conventional practice to install a compacted granular fill layer, at a convenient elevation, to allow the equipment to access the site without getting stuck.

A typical working platform could consist of 0.6 m of OPSS Granular B, Type II crushed stone which is placed and compacted to a minimum of 98% of its standard Proctor maximum dry density (SPMDD) in lifts not exceeding 300 mm in thickness.

Once the piles have been driven and cut off, the working platform can be regraded, and soil tracked in, or soil pumping up from the pile installation locations, can be bladed off and the surface can be topped up, if necessary, and re-compacted to act as the substrate for further fill placement for the basement slab.

Vibration Considerations

Construction operations could be the cause of vibrations, and possibly, sources of nuisance to the community. Therefore, means to reduce the vibration levels as much as possible should be incorporated in the construction operations to maintain a cooperative environment with the residents.

The following construction equipment could be the source of vibrations: pile driving rig, compactor, dozer, crane, truck traffic, etc. Vibrations, whether caused by pile driving (if required) or other construction operations, could be the cause or the source of detrimental vibrations at the nearby buildings and structures. Therefore, it is recommended that all vibrations be limited.

Two parameters determine the permissible vibrations, the maximum peak particle velocity and the frequency. For low frequency vibrations, the maximum allowable peak particle velocity is less than that for high frequency vibrations. As a guideline, the peak particle velocity should be less than 15 mm/s between frequencies of 4 to 12 Hz, and 50 mm/s above a frequency of 40 Hz (interpolate between 12 and 40 Hz). These guidelines are current construction standards. These guidelines are above perceptible human level and, in some cases, could be very disturbing to some people, a pre-construction survey is recommended to minimize the risks of claims during or following the construction of the proposed building.

Should the proposed multi-storey building be supported on a pile foundation, a pre-construction survey of the existing structures located in proximity of the pile driving operations should be conducted prior to commencing construction. The extent of the survey should be sufficient to respond to any inquiries/claims related to the blasting operations.

Fill Placement

Fill used for grading beneath the proposed building should consist of clean imported granular fill, such as Ontario Provincial Standard Specifications (OPSS) Granular A or Granular B Type II. This material should be tested and approved prior to delivery to the site. The fill should be placed in lifts no greater than 300 mm thick and compacted using suitable compaction equipment for the lift thickness. Fill placed beneath the building and paved areas should be compacted to at least 98% of the material's standard Proctor maximum dry density (SPMDD).

Non-specified existing fill, along with site-excavated soil, can be used as general landscaping fill where settlement of the ground surface is of minor concern. This material should be spread in thin lifts and at least compacted by the tracks of the spreading equipment to minimize voids. If this material is to be used to build up the subgrade level for areas to be paved, it should be compacted in thin lifts to at least 95% of the material's SPMDD.

Non-specified existing fill and site-excavated soils are not suitable for use as backfill against foundation walls unless used in conjunction with a composite drainage membrane.

5.3 Foundation Design

Bearing Resistance Values for Exterior Columns and Auxiliary Structures

Where required, strip footings, up to 3 m wide, and pad footings, up to 5 m wide, placed on an undisturbed, stiff silty clay bearing surface can be designed using a bearing resistance value at serviceability limit states (SLS) of **120 kPa** and a factored bearing resistance value at ultimate limit states (ULS) of **180 kPa**. A geotechnical resistance factor of 0.5 was applied to the bearing resistance value at ULS.

An undisturbed soil bearing surface consists of a surface from which all topsoil and deleterious materials, such as loose, frozen or disturbed soil, whether in situ or not, have been removed, in the dry, prior to the placement of concrete for footings.

Footings designed using the above-noted bearing resistance value at SLS will be subjected to potential post-construction total and differential settlements of 25 and 20 mm, respectively.

The bearing medium under footing-supported structures is required to be provided with adequate lateral support with respect to excavations and different foundation levels. Adequate lateral support is provided to a glacial till bearing medium when a plane extending down and out from the bottom edge of the footing at a minimum of 1.5H:1V, passes only through in situ soil or engineered fill of the same or higher capacity as the soil.

Raft Foundation

As noted above, it is expected that a raft foundation will be required to support the proposed multi-storey building. For our design calculations, one level of underground parking was assumed which would extend approximately 3 to 3.5 m below existing ground surface. The maximum SLS contact pressure is **150 kPa** for a raft foundation bearing on the undisturbed, stiff silty clay. It should be noted that the weight of the raft slab and everything above has to be included when designing with this value. The loading conditions for the contact pressure are based on sustained loads, that are generally taken to be 100% Dead Load and 50% Live Load. The factored bearing resistance (contact pressure) at ULS can be taken as **225 kPa**. A geotechnical resistance factor of 0.5 was applied to the bearing resistance value at ULS.

The modulus of subgrade reaction was calculated to be **6 MPa/m** for a contact pressure of **150 kPa**. The design of the raft foundation is required to consider the relative stiffness of the reinforced concrete slab and the supporting bearing medium. A common method of modeling the soil structure interaction is to consider the bearing medium to be elastic and to assign a subgrade modulus. However, glacial till is not elastic and limits have to be placed on the stress ranges of a particular modulus.

The proposed building can be designed using the above parameters with total and differential settlements of 25 and 20 mm, respectively.

Paterson should review the final raft bearing pressure distribution diagram for conformance with the recommendations provided above.

Pile Foundation

Should the maximum SLS contact pressure provided above for a raft foundation be insufficient for support of the proposed multi-storey building, a deep foundation system driven to refusal in the bedrock would be required to provide adequate foundation

support. For deep foundations, concrete-filled steel pipe piles are generally utilized in the Ottawa area. Applicable pile resistance values at ultimate limit states (ULS) are given in Table 2 below. A resistance factor of 0.4 has been incorporated into the factored ULS values. Note that these are all geotechnical axial resistance values.

Table 2 - Pile Foundation Design Data				
Pile Outside Diameter (mm)	Pile Wall Thickness (mm)	Geotechnical Axial Resistance	Final Set (blows/12 mm)	Transferred Hammer Energy (kJ)
		Factored at ULS (kN)		
245	9	1090	10	28.5
245	11	1260	10	34.2
245	13	1500	10	40.7

Re-striking of all piles, at least once, will also be required after at least 48 hours have elapsed since initial driving. A full-time field review program should be conducted during the pile driving operations to record the pile lengths, ensure that the refusal criteria is met and that piles are driven within the location tolerances (within 75 mm of proper location and within 2% of vertical).

The minimum recommended centre-to-centre pile spacing is 2.5 times the pile diameter. The closer the piles are spaced, however, the more potential that the driving of subsequent piles in a group could have influence on piles in the group that have already been driven. These effects, primarily consisting of uplift of previously driven piles, are checked as part of the field review of the pile driving operations.

Prior to the commencement of production pile driving, a limited number of indicator piles should be installed across the site. It is recommended that each indicator pile be dynamically load tested to evaluate pile stresses, hammer efficiency, pile load transfer, and end-of-driving criteria for end-bearing in the bedrock.

Permissible Grade Raise

Due to the presence of the silty clay deposit, a permissible grade raise restriction of **1.5 m** is recommended for grading at the subject site.

If higher than permissible grade raises are required, preloading with or without a surcharge, lightweight fill, and/or other measures should be investigated to reduce the risks of unacceptable long-term post construction total and differential settlements.

5.4 Design for Earthquakes

The site class for seismic site response can be taken as **Class D**. Soils underlying the subject site are not susceptible to liquefaction. Reference should be made to the latest revision of the Ontario Building Code 2012 for a full discussion of the earthquake design requirements.

5.5 Basement Floor Slab

If a raft slab is considered, a granular layer of OPSS Granular A is recommended to allow for the installation of sub-floor services above the raft slab foundation. The thickness of the OPSS Granular A crushed stone will be dependent on the piping requirements.

For a building founded on piles, it is recommended that the upper 200 mm of subfloor fill consists of 19 mm clear crushed stone, which is placed over an undisturbed, stiff silty clay subgrade.

An underslab drainage system, consisting of lines of perforated drainage pipe subdrains connected to a positive outlet, should be provided under the lowest level floor slab. The spacing of the underslab drainage pipes can be determined at the time of construction to confirm groundwater infiltration levels, if any. This is discussed further in Subsection 6.1.

5.6 Basement Wall

There are several combinations of backfill materials and retained soils that could be applicable for the basement walls of the subject structure. However, the conditions can be well-represented by assuming the retained soil consists of a material with an angle of internal friction of 30 degrees and a bulk (drained) unit weight of 20 kN/m³.

Where undrained conditions are anticipated (i.e. below the groundwater level), the applicable effective (undrained) unit weight of the retained soil can be taken as 13 kN/m³, where applicable. A hydrostatic pressure should be added to the total static earth pressure when using the effective unit weight.

Lateral Earth Pressures

The static horizontal earth pressure (p_o) can be calculated using a triangular earth pressure distribution equal to $K_o \cdot \gamma \cdot H$ where:

- K_o = at-rest earth pressure coefficient of the applicable retained soil (0.5)
 γ = unit weight of fill of the applicable retained soil (kN/m³)
 H = height of the wall (m)

An additional pressure having a magnitude equal to $K_o \cdot q$ and acting on the entire height of the wall should be added to the above diagram for any surcharge loading, q (kPa), that may be placed at ground surface adjacent to the wall. The surcharge pressure will only be applicable for static analyses and should not be used in conjunction with the seismic loading case.

Actual earth pressures could be higher than the “at-rest” case if care is not exercised during the compaction of the backfill materials to maintain a minimum separation of 0.3 m from the walls with the compaction equipment.

Seismic Earth Pressures

The total seismic force (P_{AE}) includes both the earth force component (P_o) and the seismic component (ΔP_{AE}).

The seismic earth force (ΔP_{AE}) can be calculated using $0.375 \cdot a_c \cdot \gamma \cdot H^2/g$ where:

- $a_c = (1.45 - a_{max}/g) a_{max}$
 γ = unit weight of fill of the applicable retained soil (kN/m³)
 H = height of the wall (m)
 g = gravity, 9.81 m/s²

The peak ground acceleration, (a_{max}), for the Ottawa area is 0.32g according to OBC 2012. Note that the vertical seismic coefficient is assumed to be zero.

The earth force component (P_o) under seismic conditions can be calculated using $P_o = 0.5 K_o \gamma H^2$, where $K_o = 0.5$ for the soil conditions noted above.

The total earth force (P_{AE}) is considered to act at a height, h (m), from the base of the wall, where:

$$h = \{P_o \cdot (H/3) + \Delta P_{AE} \cdot (0.6 \cdot H)\} / P_{AE}$$

The earth forces calculated are unfactored. For the ULS case, the earth loads should be factored as live loads, as per OBC 2012.

5.7 Pavement Structure

Should a flexible pavement be required for the project, the recommended flexible pavement structures shown in Tables 3 and 4 would be applicable.

Table 3 - Recommended Flexible Pavement Structure - Car Only Parking Areas	
Thickness (mm)	Material Description
50	Wear Course - HL-3 or Superpave 12.5 Asphaltic Concrete
150	BASE - OPSS Granular A Crushed Stone
300	SUBBASE - OPSS Granular B Type II
	SUBGRADE - Either fill, in situ soil or OPSS Granular B Type I or II material placed over in situ soil or fill

Table 4 - Recommended Flexible Pavement Structure - Access Lanes and Ramp	
Thickness (mm)	Material Description
40	Wear Course - HL-3 or Superpave 12.5 Asphaltic Concrete
50	Binder Course - HL-8 or Superpave 19.0 Asphaltic Concrete
150	BASE - OPSS Granular A Crushed Stone
400	SUBBASE - OPSS Granular B Type II
	SUBGRADE - Either fill, in situ soil or OPSS Granular B Type I or II material placed over in situ soil or fill

Minimum Performance Graded (PG) 58-34 asphalt cement should be used for this project.

If soft spots develop in the subgrade during compaction or due to construction traffic, the affected areas should be excavated and replaced with OPSS Granular B Type II material. The pavement granular base and subbase should be placed in maximum 300 mm thick lifts and compacted to a minimum of 99% of the SPMDD using suitable vibratory equipment.

6.0 Design and Construction Precautions

6.1 Foundation Drainage and Backfill

Foundation Drainage

It is recommended that a perimeter foundation drainage system be provided for the proposed building. The system should consist of a 150 mm diameter perforated and corrugated plastic pipe, surrounded on all sides by 150 mm of 10 mm clear crushed stone, which is placed at the footing level around the exterior perimeter of the structure. The pipe should have a positive outlet, such as a gravity connection to the storm sewer.

Where insufficient room is available for exterior backfill, it is suggested that the composite drainage system (such as Delta Drain 6000 or equivalent) be secured against the temporary shoring system extending to a series of drainage sleeve inlets through the building foundation wall. The drainage sleeves should be at least 150 mm diameter and be spaced 3 m along the perimeter foundation walls. An interior perimeter drainage pipe should be placed along the building perimeter along with the sub-slab drainage system. The perimeter drainage pipe and sub-slab drainage system should direct water to sump pit(s) within the lower garage area.

Foundation Raft Slab Construction Joints

It is expected that the raft slab, where utilized, will be poured in sections. For the construction joint at each pour, a rubber water stop along with a chemical grout (Xypex or equivalent) should be applied to the entire vertical joint of the slab. Furthermore, a rubber water stop should be incorporated in the horizontal interface between the foundation wall and the raft slab.

Underslab Drainage

Underslab drainage will be required to control water infiltration below the lowest level floor slab. For preliminary design purposes, we recommend that 100 or 150 mm perforated pipes be placed at approximate 6 m centres. The spacing of the sub-slab drainage system should be confirmed at the time of completing the excavation when water infiltration can be better assessed.

Foundation Backfill

Where space is available, backfill against the exterior sides of the foundation walls should consist of free-draining, non frost susceptible granular materials. The greater part of the site excavated materials will be frost susceptible and, as such, are not recommended for re-use as backfill against the foundation walls unless used in conjunction with a composite drainage system, such as Delta Drain 6000 or an approved equivalent. Imported granular materials, such as clean sand or OPSS Granular B Type I granular material, should otherwise be used for this purpose.

6.2 Protection of Footings Against Frost Action

Perimeter foundations of heated structures are required to be insulated against the deleterious effects of frost action. A minimum of 1.5 m of soil cover, or a minimum of 0.6 m of soil cover in conjunction with adequate foundation insulation, should be provided.

Exterior unheated foundations, such as those for isolated exterior columns, are more prone to deleterious movement associated with frost action than the exterior walls of the heated structure and require additional protection, such as soil cover of 2.1 m or an equivalent combination of soil cover and foundation insulation.

However, the foundations are expected to have sufficient frost protection due to the founding depth. Unheated structures such as the access ramp may require insulation against the deleterious effect of frost action.

6.3 Excavation Side Slopes

The side slopes of excavations in the soil and fill overburden materials should either be excavated at acceptable slopes or retained by shoring systems from the beginning of the excavation until the structure is backfilled. Given that the proposed building is anticipated to extend to the property lines, it is expected that a temporary shoring will be required to support the excavation.

Unsupported Excavations

The excavation side slopes above the groundwater level extending to a maximum depth of 3 m should be excavated at 1H:1V or shallower. The shallower slope is required for excavation below groundwater level. The subsurface soils are considered to be a Type 2 and 3 soil according to the Occupational Health and Safety Act and Regulations for Construction Projects.

Excavated soil should not be stockpiled directly at the top of excavations and heavy equipment should be kept away from the excavation sides.

Slopes in excess of 3 m in height should be periodically inspected by the geotechnical consultant in order to detect if the slopes are exhibiting signs of distress.

A trench box is recommended to protect personnel working in trenches with steep or vertical sides. Services are expected to be installed by “cut and cover” methods and excavations should not remain open for extended periods of time.

Temporary Shoring

Temporary shoring is anticipated to be required to support the overburden soils due to the proximity of the underground parking level to the property lines. The design and approval of the shoring system will be the responsibility of the shoring contractor and the shoring designer who is a licensed professional engineer and is hired by the shoring contractor. It is the responsibility of the shoring contractor to ensure that the temporary shoring is in compliance with safety requirements, designed to avoid any damage to adjacent structures and include dewatering control measures. In the event that subsurface conditions differ from the approved design during the actual installation, it is the responsibility of the shoring contractor to commission the required experts to re-assess the design and implement the required changes.

Furthermore, the design of the temporary shoring system should take into consideration a full hydrostatic condition which can occur during significant precipitation events. The temporary shoring system may consist of a soldier pile and lagging system which could be cantilevered, anchored or braced.

Any additional loading due to street traffic, construction equipment, adjacent structures and facilities, etc., should be added to the earth pressures described below. The earth pressures acting on the shoring system may be calculated using the following parameters.

Table 5 - Soil Parameters	
Parameters	Values
Active Earth Pressure Coefficient (K_a)	0.33
Passive Earth Pressure Coefficient (K_p)	3
At-Rest Earth Pressure Coefficient (K_o)	0.5
Unit Weight (γ), kN/m ³	21
Submerged Unit Weight (γ), kN/m ³	13

The active earth pressure should be calculated where wall movements are permissible while the at-rest pressure should be calculated if no movement is permissible. The dry unit weight should be calculated above the groundwater level while the effective unit weight should be calculated below the groundwater level.

The hydrostatic groundwater pressure should be included to the earth pressure distribution wherever the effective unit weight are calculated for earth pressures. If the groundwater level is lowered, the dry unit weight for the soil/bedrock should be calculated full weight, with no hydrostatic groundwater pressure component.

For design purposes, the minimum factor of safety of 1.5 should be calculated.

Underpinning of Adjacent Structures

As the excavation for the proposed basement level will abut the existing building located in the southwest corner of the site, and the adjacent building to the northwest of the subject site, underpinning will be required if the proposed building foundations extend below the depth of the existing building foundations. It is recommended that test pits be completed prior to construction, or at the start of construction, in order to evaluate the foundation depths of the existing structures for underpinning requirements.

Conventional timber lagged pits and concrete underpinning piers are considered to be suitable for this project. The depth of the underpinning, should it be required, will be dependent on the depth of the adjacent foundations relative to the foundation depths of the proposed addition at the subject site.

6.4 Pipe Bedding and Backfill

At least 150 mm of OPSS Granular A should be used for pipe bedding for sewer and water pipes. However, the bedding thickness should be increased to 300 mm for areas over a grey silty clay subgrade. The bedding should extend to the spring line of the pipe. Cover material, from the spring line to at least 300 mm above the obvert of the pipe, should consist of OPSS Granular A or Granular B Type II with a maximum size of 50 mm. The bedding and cover materials should be placed in maximum 225 mm thick lifts compacted to 95% of the material's standard Proctor maximum dry density. It should generally be possible to re-use the site materials above the cover material if the operations are carried out in dry weather conditions. Wet silty clay materials will be difficult to re-use, at the high water contents make compacting impractical without an extensive drying period.

Where hard surface areas are considered above the trench backfill, the trench backfill material within the frost zone (about 1.5 m below finished grade) and above the cover material should match the soils exposed at the trench walls to minimize differential frost heaving. The trench backfill should be placed in maximum 225 mm thick loose lifts and compacted to a minimum of 95% of the material standard Proctor maximum dry density.

6.5 Groundwater Control

It is anticipated that groundwater infiltration into the excavations should be controllable using open sumps. The contractor should be prepared to direct water away from all bearing surfaces and subgrades, regardless of the source, to prevent disturbance to the founding medium.

Groundwater Control for Building Construction

A temporary Ministry of the Environment, Conservation, and Parks (MECP) permit to take water (PTTW) may be required for this project if more than 400,000 L/day of ground and/or surface water is to be pumped during the construction phase. A minimum of 4 to 5 months should be allowed for completion of the PTTW application package and issuance of the permit by the MECP.

For typical ground or surface water volumes being pumped during the construction phase, between 50,000 to 400,000 L/day, it is required to register on the Environmental Activity and Sector Registry (EASR). A minimum of two to four weeks should be allotted for completion of the EASR registration and the Water Taking and Discharge Plan to be prepared by a Qualified Person as stipulated under O.Reg. 63/16. If a project qualifies for a PTTW based upon anticipated conditions, an EASR will not be allowed as a temporary dewatering measure while awaiting the MECP review of the PTTW application.

Impacts on Neighbouring Properties

Based on the existing groundwater level encountered during the geotechnical investigation, the proposed building construction will not extend below the groundwater level. Therefore, groundwater lowering is not anticipated during or after construction, and accordingly, the proposed development will not negatively impact the neighbouring structures.

6.6 Winter Construction

Precautions must be taken if winter construction is considered for this project.

The subsoil conditions at this site mostly consist of frost susceptible materials. In the presence of water and freezing conditions, ice could form within the soil mass. Heaving and settlement upon thawing could occur.

In the event of construction during below zero temperatures, the founding stratum should be protected from freezing temperatures by the use of straw, propane heaters, tarpaulins or other suitable means. In this regard, the base of the excavations should be insulated from sub-zero temperatures immediately upon exposure and until such time as heat is adequately supplied to the building and the footings are protected with sufficient soil cover to prevent freezing at founding level.

The trench excavations should be carried out in a manner to avoid the introduction of frozen materials, snow or ice into the trenches.

6.7 Corrosion Potential and Sulphate

The results of analytical testing show that the sulphate content is less than 0.1%. This result is indicative that Type 10 Portland cement (normal cement) would be appropriate for this site. The chloride content and the pH of the sample indicate that they are not significant factors in creating a corrosive environment for exposed ferrous metals at this site, whereas the resistivity is indicative of a non-aggressive to slightly aggressive corrosive environment.

7.0 Recommendations

A materials testing and observation services program is a requirement for the provided foundation design data to be applicable. The following aspects of the program should be performed by the geotechnical consultant:

- Review of the grading plan from a geotechnical perspective.
- Review the Contractor's design of the temporary shoring system.
- Observe test pits to determine requirements for underpinning of adjacent structures.
- Observation of all bearing surfaces prior to the placement of concrete.
- Sampling and testing of the concrete and fill materials used.
- Periodic observation of the condition of unsupported excavation side slopes in excess of 3 m in height, if applicable.
- Observation of all subgrades prior to backfilling.
- Field density tests to determine the level of compaction achieved.
- Sampling and testing of the bituminous concrete including mix design reviews.

A report confirming that these works have been conducted in general accordance with our recommendations could be issued, upon request, following the completion of a satisfactory materials testing and observation program by the geotechnical consultant.

8.0 Statement of Limitations

The recommendations provided in this report are in accordance with our present understanding of the project. We request that we be permitted to review the grading plan once available and to review our recommendations when the drawings and specifications are complete.

A geotechnical investigation is a limited sampling of a site. Should any conditions at the site be encountered which differ from those at the test locations, we request immediate notification to permit reassessment of our recommendations.

The recommendations provided herein should only be used by the design professionals associated with this project. They are not intended for contractors bidding on or undertaking the work. The latter should evaluate the factual information provided in this report and determine its suitability and completeness for their intended construction schedule and methods. Additional testing may be required for their purposes.

The present report applies only to the project described in this document. Use of this report for purposes other than those described herein or by person(s) other than Zyer Developments or their agents is not authorized without review by Paterson for the applicability of our recommendations to the altered use of the report.

Paterson Group Inc.



Kevin A. Pickard, EIT



Scott S. Dennis, P.Eng.

Report Distribution

- Zyer Developments (e-mail copy)
- Paterson Group (1 copy)

APPENDIX 1

SOIL PROFILE AND TEST DATA SHEETS

SYMBOLS AND TERMS

ANALYTICAL TESTING RESULTS

DATUM Geodetic

REMARKS

BORINGS BY CME-55 Low Clearance Drill

DATE September 4, 2020

FILE NO. **PG5489**

HOLE NO. **BH 1**

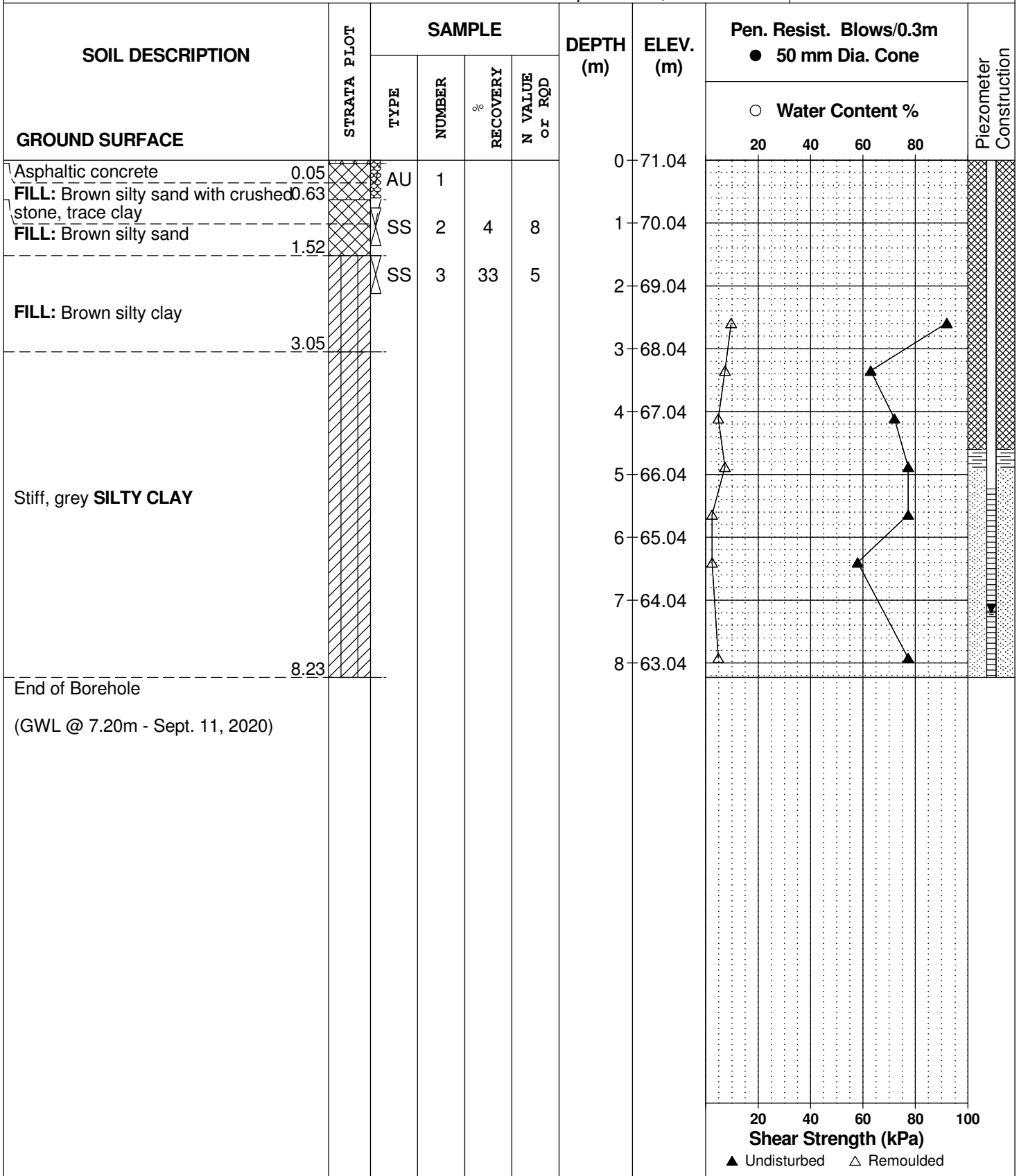

DATUM Geodetic

REMARKS

BORINGS BY CME-55 Low Clearance Drill

DATE September 4, 2020

FILE NO. **PG5489**

HOLE NO. **BH 2**

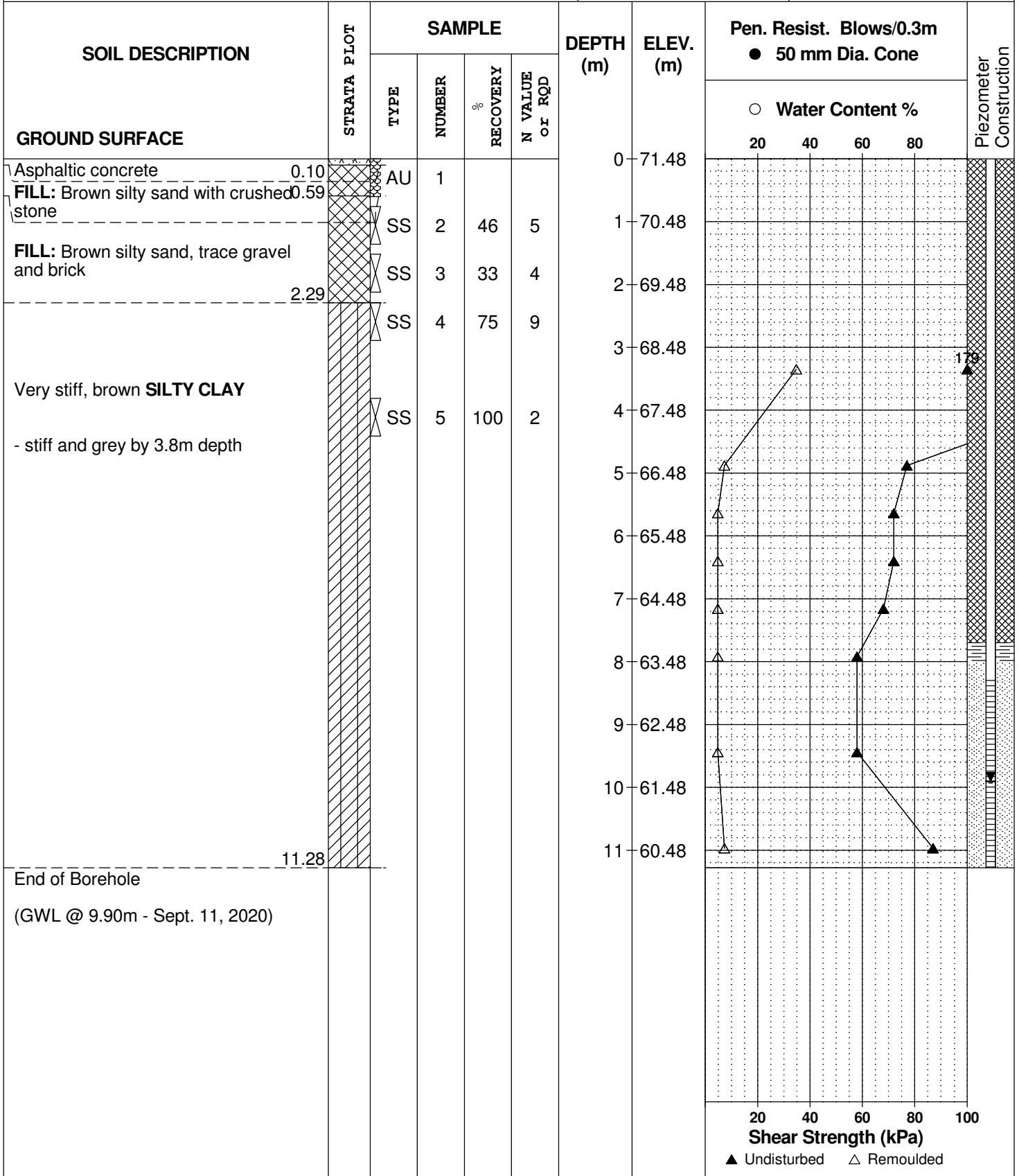

DATUM Geodetic

REMARKS

BORINGS BY CME-55 Low Clearance Drill

DATE September 4, 2020

FILE NO. **PG5489**

HOLE NO. **BH 3**

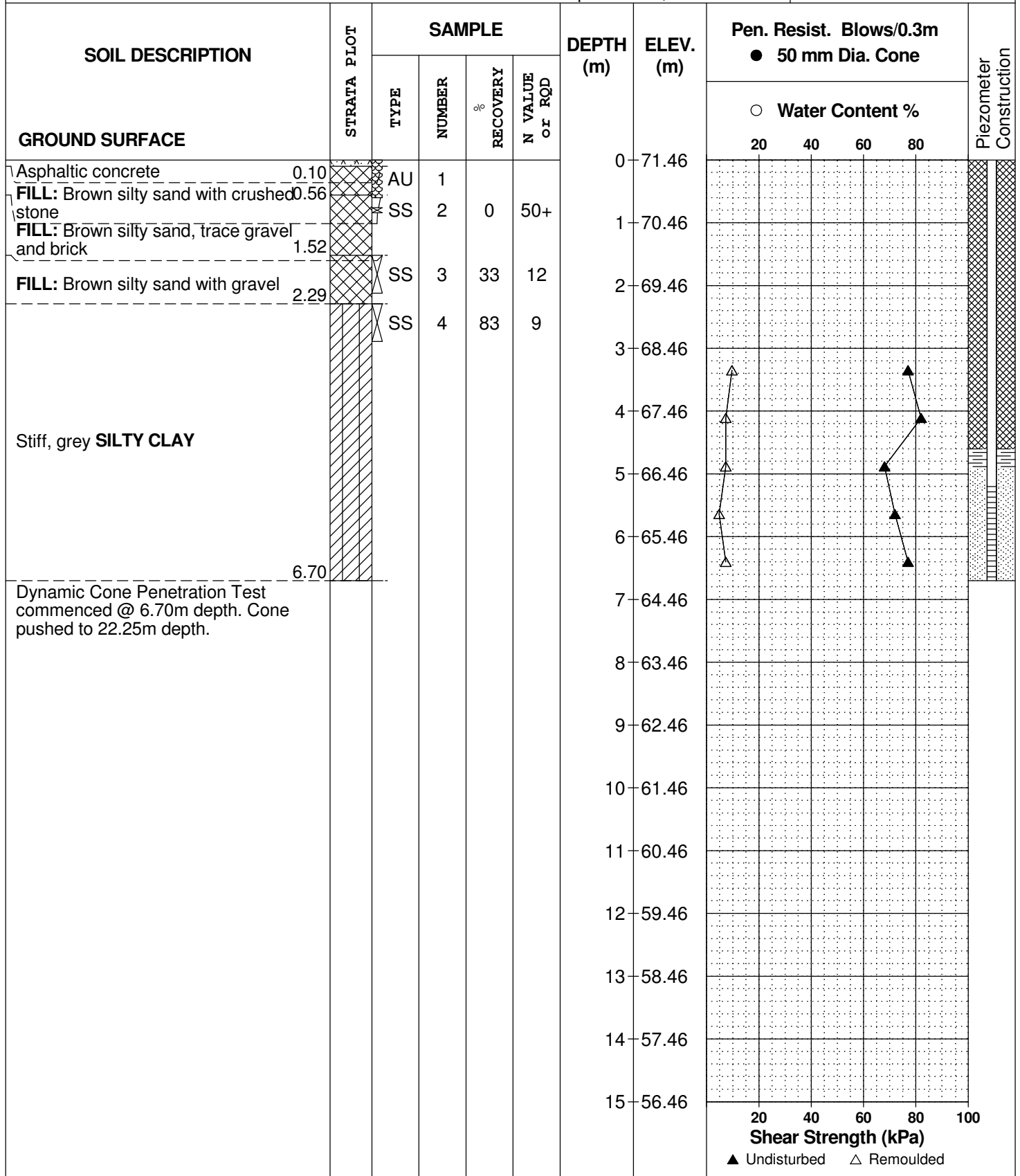

DATUM Geodetic

REMARKS

BORINGS BY CME-55 Low Clearance Drill

DATE September 4, 2020

FILE NO. **PG5489**

HOLE NO. **BH 3**

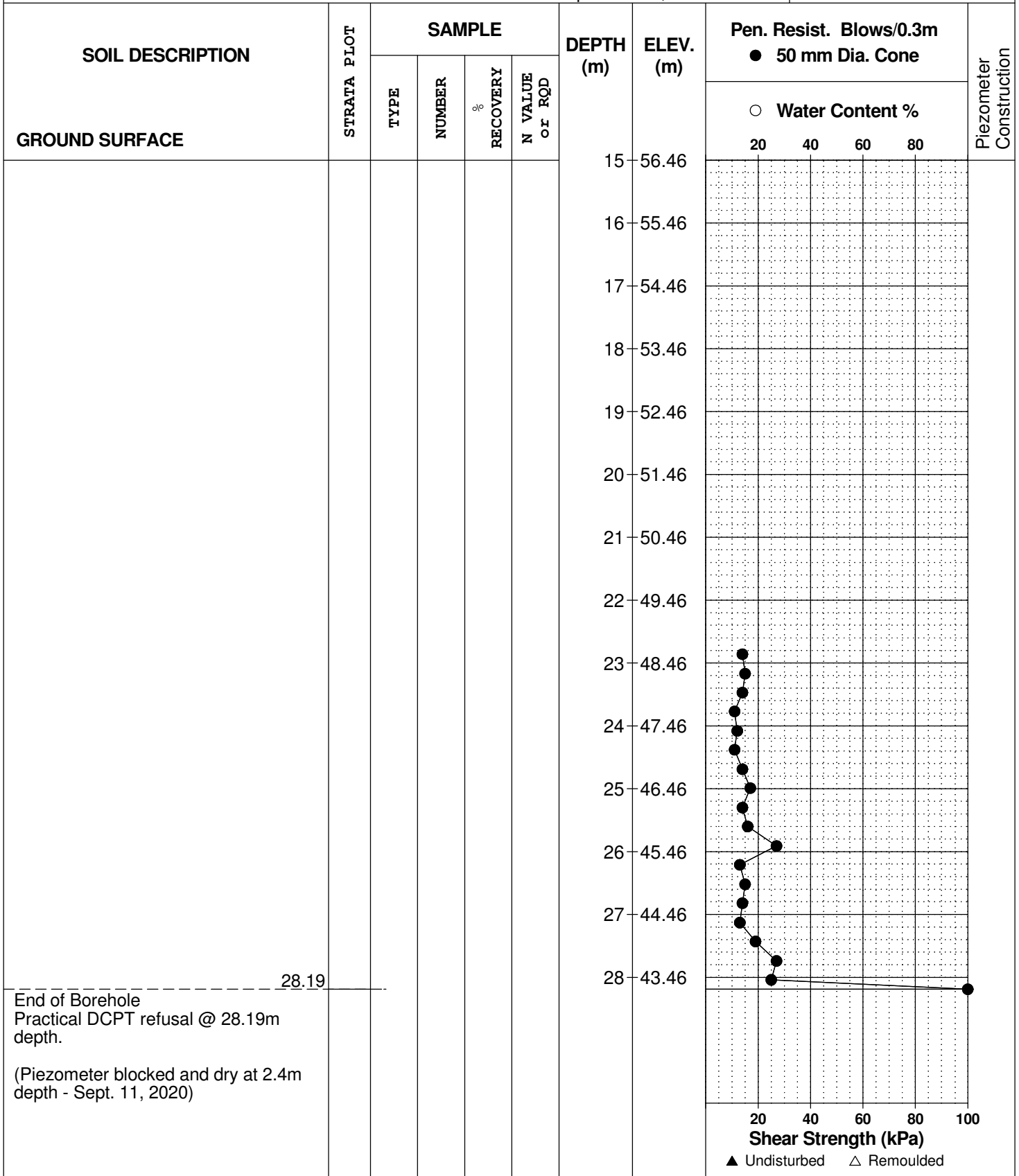

SYMBOLS AND TERMS

SOIL DESCRIPTION

Behavioural properties, such as structure and strength, take precedence over particle gradation in describing soils. Terminology describing soil structure are as follows:

Desiccated	-	having visible signs of weathering by oxidation of clay minerals, shrinkage cracks, etc.
Fissured	-	having cracks, and hence a blocky structure.
Varved	-	composed of regular alternating layers of silt and clay.
Stratified	-	composed of alternating layers of different soil types, e.g. silt and sand or silt and clay.
Well-Graded	-	Having wide range in grain sizes and substantial amounts of all intermediate particle sizes (see Grain Size Distribution).
Uniformly-Graded	-	Predominantly of one grain size (see Grain Size Distribution).

The standard terminology to describe the strength of cohesionless soils is the relative density, usually inferred from the results of the Standard Penetration Test (SPT) 'N' value. The SPT N value is the number of blows of a 63.5 kg hammer, falling 760 mm, required to drive a 51 mm O.D. split spoon sampler 300 mm into the soil after an initial penetration of 150 mm.

Relative Density	'N' Value	Relative Density %
Very Loose	<4	<15
Loose	4-10	15-35
Compact	10-30	35-65
Dense	30-50	65-85
Very Dense	>50	>85

The standard terminology to describe the strength of cohesive soils is the consistency, which is based on the undisturbed undrained shear strength as measured by the in situ or laboratory vane tests, penetrometer tests, unconfined compression tests, or occasionally by Standard Penetration Tests.

Consistency	Undrained Shear Strength (kPa)	'N' Value
Very Soft	<12	<2
Soft	12-25	2-4
Firm	25-50	4-8
Stiff	50-100	8-15
Very Stiff	100-200	15-30
Hard	>200	>30

SYMBOLS AND TERMS (continued)

SOIL DESCRIPTION (continued)

Cohesive soils can also be classified according to their “sensitivity”. The sensitivity is the ratio between the undisturbed undrained shear strength and the remoulded undrained shear strength of the soil.

Terminology used for describing soil strata based upon texture, or the proportion of individual particle sizes present is provided on the Textural Soil Classification Chart at the end of this information package.

ROCK DESCRIPTION

The structural description of the bedrock mass is based on the Rock Quality Designation (RQD).

The RQD classification is based on a modified core recovery percentage in which all pieces of sound core over 100 mm long are counted as recovery. The smaller pieces are considered to be a result of closely-spaced discontinuities (resulting from shearing, jointing, faulting, or weathering) in the rock mass and are not counted. RQD is ideally determined from NXL size core. However, it can be used on smaller core sizes, such as BX, if the bulk of the fractures caused by drilling stresses (called “mechanical breaks”) are easily distinguishable from the normal in situ fractures.

RQD %	ROCK QUALITY
90-100	Excellent, intact, very sound
75-90	Good, massive, moderately jointed or sound
50-75	Fair, blocky and seamy, fractured
25-50	Poor, shattered and very seamy or blocky, severely fractured
0-25	Very poor, crushed, very severely fractured

SAMPLE TYPES

SS	-	Split spoon sample (obtained in conjunction with the performing of the Standard Penetration Test (SPT))
TW	-	Thin wall tube or Shelby tube
PS	-	Piston sample
AU	-	Auger sample or bulk sample
WS	-	Wash sample
RC	-	Rock core sample (Core bit size AXT, BXL, etc.). Rock core samples are obtained with the use of standard diamond drilling bits.

SYMBOLS AND TERMS (continued)

GRAIN SIZE DISTRIBUTION

MC%	-	Natural moisture content or water content of sample, %
LL	-	Liquid Limit, % (water content above which soil behaves as a liquid)
PL	-	Plastic limit, % (water content above which soil behaves plastically)
PI	-	Plasticity index, % (difference between LL and PL)
Dxx	-	Grain size which xx% of the soil, by weight, is of finer grain sizes These grain size descriptions are not used below 0.075 mm grain size
D10	-	Grain size at which 10% of the soil is finer (effective grain size)
D60	-	Grain size at which 60% of the soil is finer
Cc	-	Concavity coefficient = $(D_{30})^2 / (D_{10} \times D_{60})$
Cu	-	Uniformity coefficient = D_{60} / D_{10}

Cc and Cu are used to assess the grading of sands and gravels:

Well-graded gravels have: $1 < Cc < 3$ and $Cu > 4$

Well-graded sands have: $1 < Cc < 3$ and $Cu > 6$

Sands and gravels not meeting the above requirements are poorly-graded or uniformly-graded.

Cc and Cu are not applicable for the description of soils with more than 10% silt and clay (more than 10% finer than 0.075 mm or the #200 sieve)

CONSOLIDATION TEST

p'_o	-	Present effective overburden pressure at sample depth
p'_c	-	Preconsolidation pressure of (maximum past pressure on) sample
Ccr	-	Recompression index (in effect at pressures below p'_c)
Cc	-	Compression index (in effect at pressures above p'_c)
OC Ratio		Overconsolidation ratio = p'_c / p'_o
Void Ratio		Initial sample void ratio = volume of voids / volume of solids
Wo	-	Initial water content (at start of consolidation test)

PERMEABILITY TEST

k	-	Coefficient of permeability or hydraulic conductivity is a measure of the ability of water to flow through the sample. The value of k is measured at a specified unit weight for (remoulded) cohesionless soil samples, because its value will vary with the unit weight or density of the sample during the test.
---	---	--

SYMBOLS AND TERMS (continued)

STRATA PLOT



Topsoil



Asphalt

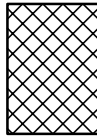

Fill



Peat

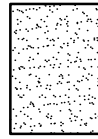

Sand

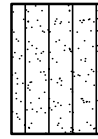

Silty Sand

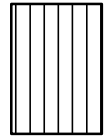

Silt



Sandy Silt

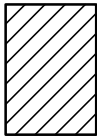

Clay

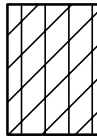

Silty Clay



Clayey Silty Sand



Glacial Till

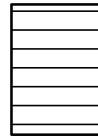

Shale

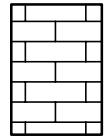

Bedrock

MONITORING WELL AND PIEZOMETER CONSTRUCTION

MONITORING WELL CONSTRUCTION



PIEZOMETER CONSTRUCTION

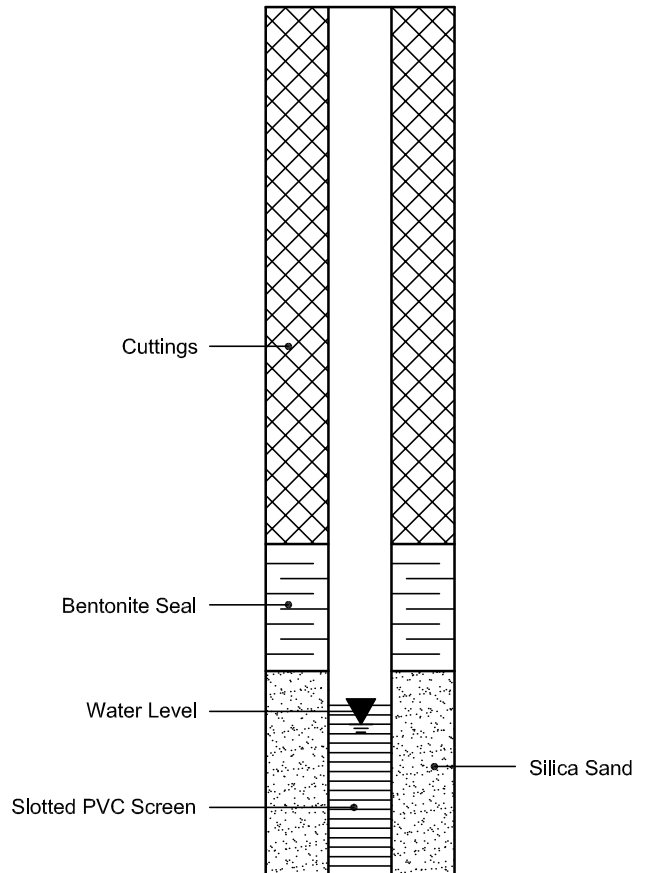

Certificate of Analysis

Report Date: 14-Sep-2020

Client: Paterson Group Consulting Engineers

Order Date: 8-Sep-2020

Client PO: 30820

Project Description: PG5489

Client ID:	BH2-SS4	-	-	-
Sample Date:	04-Sep-20 08:50	-	-	-
Sample ID:	2037133-01	-	-	-
MDL/Units	Soil	-	-	-

Physical Characteristics

% Solids	0.1 % by Wt.	69.5	-	-	-
----------	--------------	------	---	---	---

General Inorganics

pH	0.05 pH Units	7.43	-	-	-
Resistivity	0.10 Ohm.m	4.63	-	-	-

Anions

Chloride	5 ug/g dry	1420	-	-	-
Sulphate	5 ug/g dry	79	-	-	-

APPENDIX 2

FIGURE 1 - KEY PLAN

DRAWING PG5489-1 - TEST HOLE LOCATION PLAN

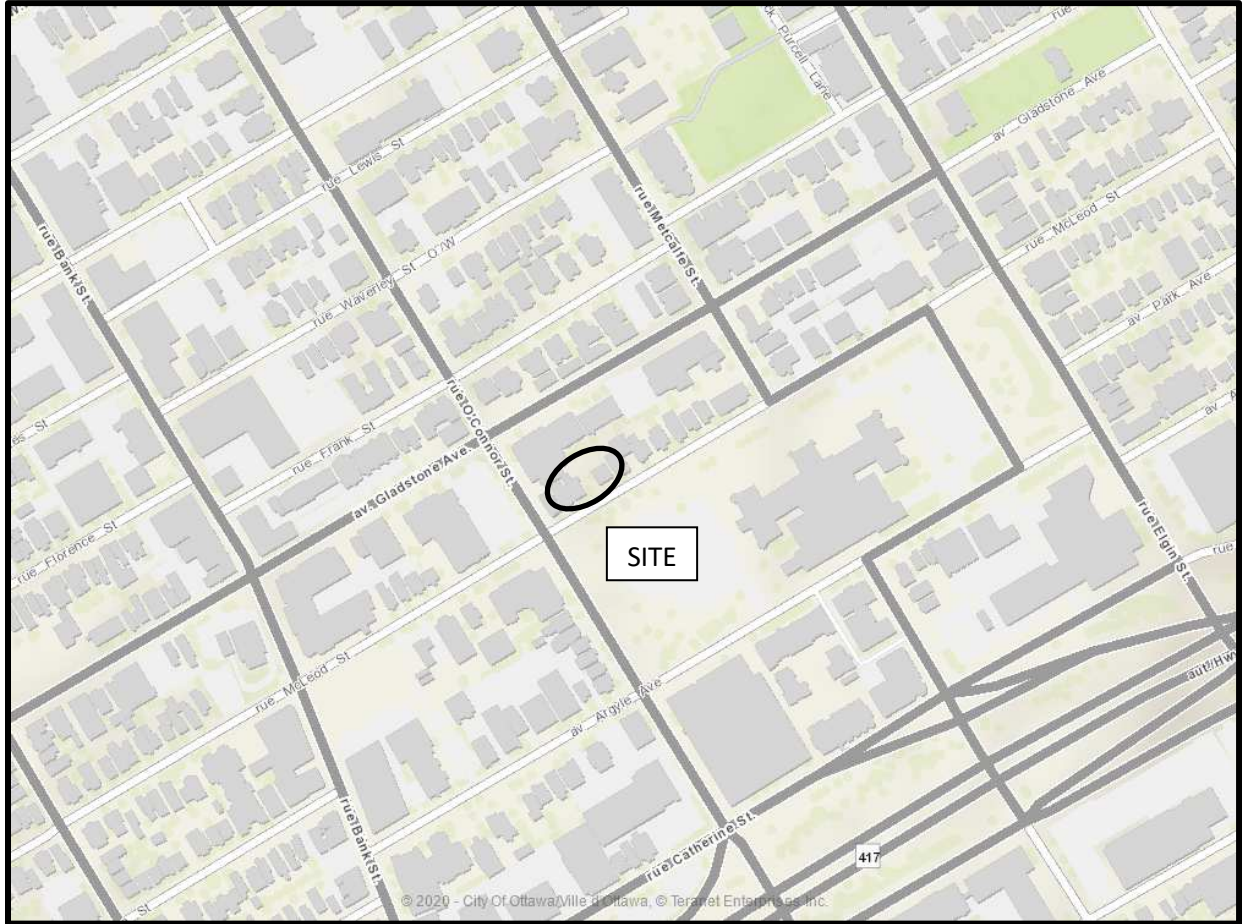
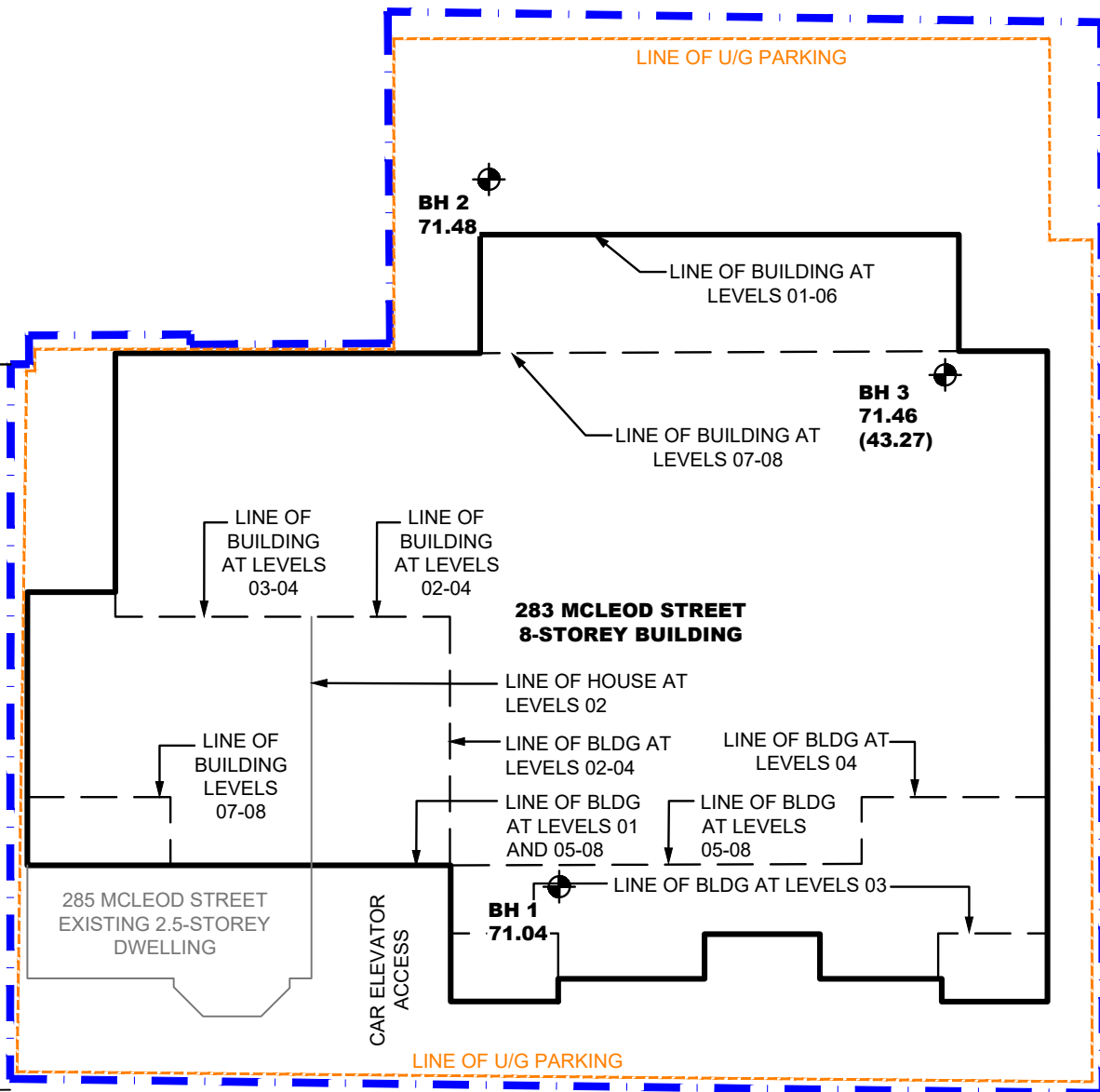
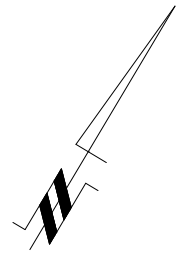



FIGURE 1

KEY PLAN

O'CONNOR STREET



MCLEOD STREET

LEGEND:
 BOREHOLE LOCATION
 71.46 GROUND SURFACE ELEVATION (m)
 (43.27) PRACTICAL DCPT REFUSAL ELEVATION (m)
 CONCEPTUAL PLAN PROVIDED BY GRC ARCHITECTS
 GROUND SURFACE ELEVATIONS AT BOREHOLE LOCATIONS ARE REFERENCED TO A GEODETIC DATUM

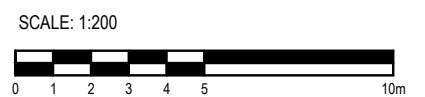

patersongroup
 consulting engineers

154 Colonnade Road South
 Ottawa, Ontario K2E 7J5
 Tel: (613) 226-7381 Fax: (613) 226-6344

NO.	REVISIONS	DATE	INITIAL
1	UPDATED TO NEW CONCEPTUAL PLAN	13/07/2021	SD

ZYER DEVELOPMENTS INC.
 GEOTECHNICAL INVESTIGATION
 PROPOSED MULTI-STOREY BUILDING - 283 AND 285 MCLEOD STREET
 OTTAWA, ONTARIO
 Title: **TEST HOLE LOCATION PLAN**

Scale:	1:200	Date:	09/2020
Drawn by:	YA	Report No.:	PG5489-1
Checked by:	KP	Dwg. No.:	PG5489-1
Approved by:	DJG	Revision No.:	1

p:\autocad\drawings\geotechnical\pg5489-1-test hole location plan (rev.01).dwg

E.2 GEOTECHNICAL MEMO BY PATERSON GROUP (OCTOBER 2022)





re: **Geotechnical Investigation – Response to City Comments**
Proposed Multi-Storey Building
283-285 McLeod Street
Ottawa, Ontario

to: Zyer Developments - **Mr. Kevin Zhang** – kevinzhang@zyerdevelopments.com

date: October 17, 2022

file: PG5489-MEMO.01

Further to your request and authorization, Paterson Group (Paterson) prepared this memorandum to provide responses to the geotechnical-related comments from the City of Ottawa listed in the letter dated May 18, 2022 (File Nos. D01-01-21-0014 and D02-02-21-0084). This memorandum should be read in conjunction with the Geotechnical Investigation Report (Paterson Group Report PG5489-1 Revision 1 dated July 22, 2021) which has been prepared for the proposed development at the aforementioned site.

Geotechnical Investigation Comments

Comment 1: *Due to the potential for heaving and rapid deterioration of the shale bedrock that exists on this site please speak to whether a concrete mud slab to be placed on exposed bedrock. in addition, a Construction Dewatering Management Plan is required to assist in the protection of shale bedrock against excessive dewatering and exposure to ambient air.*

Response: The proposed multi-storey building is understood to include 1 below-grade level, which is anticipated to extend to depths of about 4 to 5 m below the existing ground surface.

As the inferred bedrock surface was encountered in borehole BH 3 at an approximate depth of 28 m, the shale bedrock will not be exposed during the proposed building excavation, and therefore measures to prevent deterioration of the shale bedrock, such as a concrete mud slab or a Construction Dewatering Management Plan, are not required.

Comment 2: *As per report, any excavation utilizing hoe ramming and/or sheet piling, pile driving and/or rock anchors for shoring or foundation support will require a Pre-Construction Survey for existing dwellings. This will include investigation survey within 75 metres of site with notice of planned work to dwellings within 150 metres of site. In addition, in the event blasting is utilized, due to shallow/dense rock, relative to proposed basement/UG garage levels, a Pre-Blast Survey will be required for existing dwellings within 75 metres of site with notice of work to dwellings within 150 metres of site.*





Response: As noted above, the excavation to the founding level of the proposed multi-storey building will be within the overburden material. Therefore, no blasting or hoe ramming is required at the subject site.

However, should the proposed construction program include pile driving, sheet piles, or other activity which produces significant vibrations, a pre-construction survey will be completed for structures within 75 m of the site, and notice of planned work will be provided for structures within 150 m of the site.

We trust that this information satisfies your immediate requirements.

Best Regards,

Paterson Group Inc.

Zubaida Al-Moselly, P.Eng.



Scott S. Dennis, P.Eng.

Appendix F COMPLETED DEVELOPMENT SERVICING STUDY CHECKLIST



Servicing study guidelines for development applications

4. Development Servicing Study Checklist

The following section describes the checklist of the required content of servicing studies. It is expected that the proponent will address each one of the following items for the study to be deemed complete and ready for review by City of Ottawa Infrastructure Approvals staff.

The level of required detail in the Servicing Study will increase depending on the type of application. For example, for Official Plan amendments and re-zoning applications, the main issues will be to determine the capacity requirements for the proposed change in land use and confirm this against the existing capacity constraint, and to define the solutions, phasing of works and the financing of works to address the capacity constraint. For subdivisions and site plans, the above will be required with additional detailed information supporting the servicing within the development boundary.

4.1 General Content

- Executive Summary (for larger reports only).
- Date and revision number of the report.
- Location map and plan showing municipal address, boundary, and layout of proposed development.
- Plan showing the site and location of all existing services.
- Development statistics, land use, density, adherence to zoning and official plan, and reference to applicable subwatershed and watershed plans that provide context to which individual developments must adhere.
- Summary of Pre-consultation Meetings with City and other approval agencies.
- Reference and confirm conformance to higher level studies and reports (Master Servicing Studies, Environmental Assessments, Community Design Plans), or in the case where it is not in conformance, the proponent must provide justification and develop a defensible design criteria.
- Statement of objectives and servicing criteria.
- Identification of existing and proposed infrastructure available in the immediate area.
- Identification of Environmentally Significant Areas, watercourses and Municipal Drains potentially impacted by the proposed development (Reference can be made to the Natural Heritage Studies, if available).
- Concept level master grading plan to confirm existing and proposed grades in the development. This is required to confirm the feasibility of proposed stormwater management and drainage, soil removal and fill constraints, and potential impacts to neighbouring properties. This is also required to confirm that the proposed grading will not impede existing major system flow paths.
- Identification of potential impacts of proposed piped services on private services (such as wells and septic fields on adjacent lands) and mitigation required to address potential impacts.
- Proposed phasing of the development, if applicable.

- Reference to geotechnical studies and recommendations concerning servicing.

- All preliminary and formal site plan submissions should have the following information:
 - Metric scale

 - North arrow (including construction North)

 - Key plan

 - Name and contact information of applicant and property owner

 - Property limits including bearings and dimensions

 - Existing and proposed structures and parking areas

 - Easements, road widening and rights-of-way

 - Adjacent street names

4.2 Development Servicing Report: Water

- Confirm consistency with Master Servicing Study, if available
- Availability of public infrastructure to service proposed development
- Identification of system constraints
- Identify boundary conditions
- Confirmation of adequate domestic supply and pressure
- Confirmation of adequate fire flow protection and confirmation that fire flow is calculated as per the Fire Underwriter's Survey. Output should show available fire flow at locations throughout the development.
- Provide a check of high pressures. If pressure is found to be high, an assessment is required to confirm the application of pressure reducing valves.
- Definition of phasing constraints. Hydraulic modeling is required to confirm servicing for all defined phases of the project including the ultimate design
- Address reliability requirements such as appropriate location of shut-off valves
- Check on the necessity of a pressure zone boundary modification.
- Reference to water supply analysis to show that major infrastructure is capable of delivering sufficient water for the proposed land use. This includes data that shows that the expected demands under average day, peak hour and fire flow conditions provide water within the required pressure range

- Description of the proposed water distribution network, including locations of proposed connections to the existing system, provisions for necessary looping, and appurtenances (valves, pressure reducing valves, valve chambers, and fire hydrants) including special metering provisions.
- Description of off-site required feeder mains, booster pumping stations, and other water infrastructure that will be ultimately required to service proposed development, including financing, interim facilities, and timing of implementation.
- Confirmation that water demands are calculated based on the City of Ottawa Design Guidelines.
- Provision of a model schematic showing the boundary conditions locations, streets, parcels, and building locations for reference.

4.3 Development Servicing Report: Wastewater

- Summary of proposed design criteria (Note: Wet-weather flow criteria should not deviate from the City of Ottawa Sewer Design Guidelines. Monitored flow data from relatively new infrastructure cannot be used to justify capacity requirements for proposed infrastructure).
- Confirm consistency with Master Servicing Study and/or justifications for deviations.
- Consideration of local conditions that may contribute to extraneous flows that are higher than the recommended flows in the guidelines. This includes groundwater and soil conditions, and age and condition of sewers.
- Description of existing sanitary sewer available for discharge of wastewater from proposed development.
- Verify available capacity in downstream sanitary sewer and/or identification of upgrades necessary to service the proposed development. (Reference can be made to previously completed Master Servicing Study if applicable)
- Calculations related to dry-weather and wet-weather flow rates from the development in standard MOE sanitary sewer design table (Appendix 'C') format.
- Description of proposed sewer network including sewers, pumping stations, and forcemains.
- Discussion of previously identified environmental constraints and impact on servicing (environmental constraints are related to limitations imposed on the development in order to preserve the physical condition of watercourses, vegetation, soil cover, as well as protecting against water quantity and quality).
- Pumping stations: impacts of proposed development on existing pumping stations or requirements for new pumping station to service development.
- Forcemain capacity in terms of operational redundancy, surge pressure and maximum flow velocity.
- Identification and implementation of the emergency overflow from sanitary pumping stations in relation to the hydraulic grade line to protect against basement flooding.
- Special considerations such as contamination, corrosive environment etc.

4.4 Development Servicing Report: Stormwater Checklist

- Description of drainage outlets and downstream constraints including legality of outlets (i.e. municipal drain, right-of-way, watercourse, or private property)
- Analysis of available capacity in existing public infrastructure.
- A drawing showing the subject lands, its surroundings, the receiving watercourse, existing drainage patterns, and proposed drainage pattern.
- Water quantity control objective (e.g. controlling post-development peak flows to pre-development level for storm events ranging from the 2 or 5 year event (dependent on the receiving sewer design) to 100 year return period); if other objectives are being applied, a rationale must be included with reference to hydrologic analyses of the potentially affected subwatersheds, taking into account long-term cumulative effects.
- Water Quality control objective (basic, normal or enhanced level of protection based on the sensitivities of the receiving watercourse) and storage requirements.
- Description of the stormwater management concept with facility locations and descriptions with references and supporting information.
- Set-back from private sewage disposal systems.
- Watercourse and hazard lands setbacks.
- Record of pre-consultation with the Ontario Ministry of Environment and the Conservation Authority that has jurisdiction on the affected watershed.
- Confirm consistency with sub-watershed and Master Servicing Study, if applicable study exists.
- Storage requirements (complete with calculations) and conveyance capacity for minor events (1:5 year return period) and major events (1:100 year return period).
- Identification of watercourses within the proposed development and how watercourses will be protected, or, if necessary, altered by the proposed development with applicable approvals.
- Calculate pre and post development peak flow rates including a description of existing site conditions and proposed impervious areas and drainage catchments in comparison to existing conditions.
- Any proposed diversion of drainage catchment areas from one outlet to another.
- Proposed minor and major systems including locations and sizes of stormwater trunk sewers, and stormwater management facilities.
- If quantity control is not proposed, demonstration that downstream system has adequate capacity for the post-development flows up to and including the 100 year return period storm event.
- Identification of potential impacts to receiving watercourses
- Identification of municipal drains and related approval requirements.
- Descriptions of how the conveyance and storage capacity will be achieved for the development.
- 100 year flood levels and major flow routing to protect proposed development from flooding for establishing minimum building elevations (MBE) and overall grading.

- Inclusion of hydraulic analysis including hydraulic grade line elevations.
- Description of approach to erosion and sediment control during construction for the protection of receiving watercourse or drainage corridors.
- Identification of floodplains – proponent to obtain relevant floodplain information from the appropriate Conservation Authority. The proponent may be required to delineate floodplain elevations to the satisfaction of the Conservation Authority if such information is not available or if information does not match current conditions.
- Identification of fill constraints related to floodplain and geotechnical investigation.

4.5 Approval and Permit Requirements: Checklist

The Servicing Study shall provide a list of applicable permits and regulatory approvals necessary for the proposed development as well as the relevant issues affecting each approval. The approval and permitting shall include but not be limited to the following:

- Conservation Authority as the designated approval agency for modification of floodplain, potential impact on fish habitat, proposed works in or adjacent to a watercourse, cut/fill permits and Approval under Lakes and Rivers Improvement Act. The Conservation Authority is not the approval authority for the Lakes and Rivers Improvement Act. Where there are Conservation Authority regulations in place, approval under the Lakes and Rivers Improvement Act is not required, except in cases of dams as defined in the Act.
- Application for Certificate of Approval (CofA) under the Ontario Water Resources Act.
- Changes to Municipal Drains.
- Other permits (National Capital Commission, Parks Canada, Public Works and Government Services Canada, Ministry of Transportation etc.)

4.6 Conclusion Checklist

- Clearly stated conclusions and recommendations
- Comments received from review agencies including the City of Ottawa and information on how the comments were addressed. Final sign-off from the responsible reviewing agency.
- All draft and final reports shall be signed and stamped by a professional Engineer registered in Ontario