

DREAM THEIA BLOCK 204A L

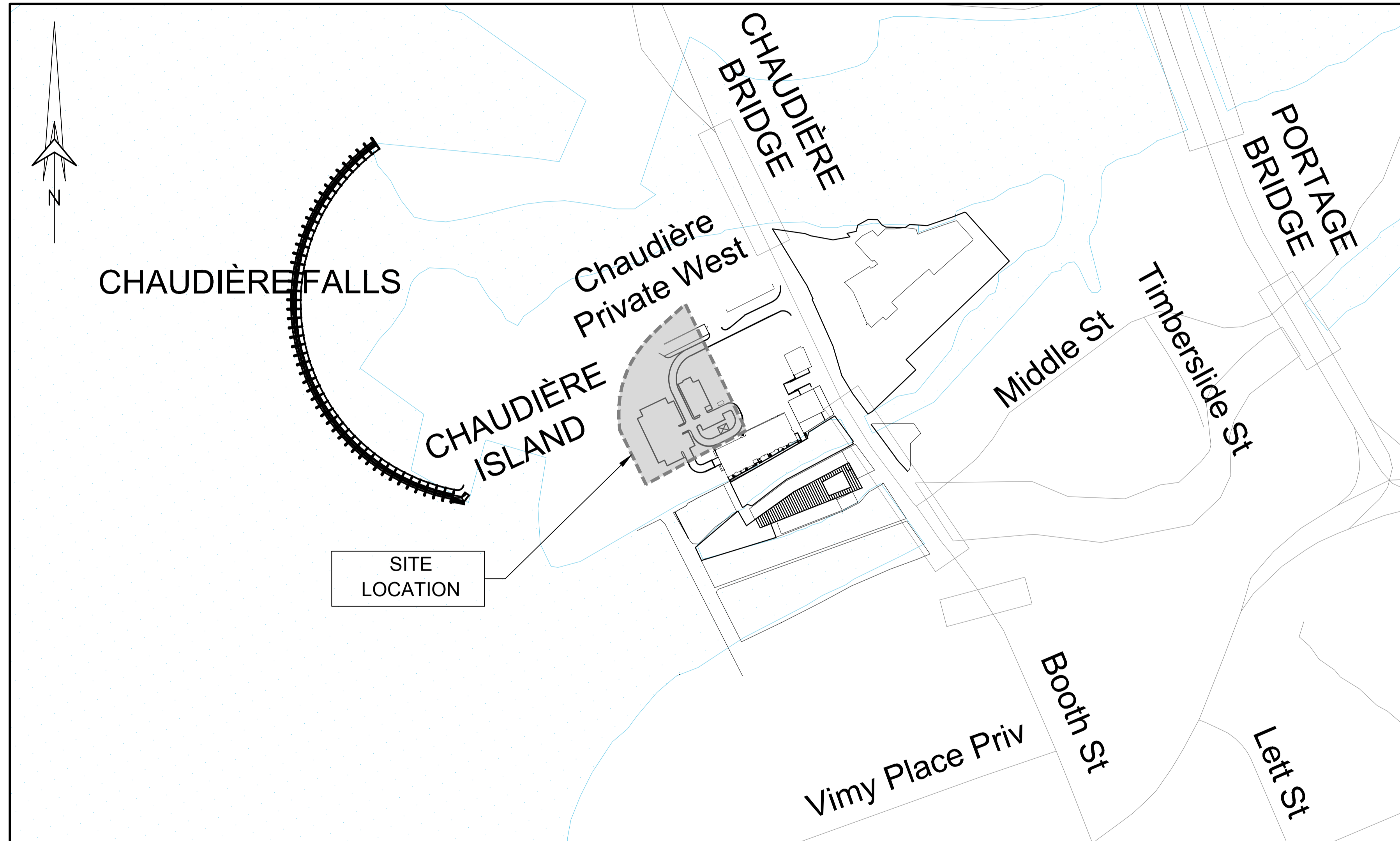

LIST OF DRAWINGS

PLAN No:	DESCRIPTION
C000	COVER PAGE
C001	TOPOGRAPHICAL SURVEY PLAN
C002	NOTES PLAN
C003	SEDIMENT AND EROSION CONTROL PLAN
C004	GRADE CONTROL AND DRAINAGE PLAN
C005	SITE SERVICING LAYOUT
C006A	PLAN AND PROFILE STA. 1+000 TO 1+145
C006B	PLAN AND PROFILE STA. 2+000 TO 2+100
C007	CROSS-SECTIONS AND DETAILS
C008	STORM WATER MANAGEMENT PLAN

ZIBI ONTARIO 315 PRIVE MIWATE, CHAUDIÈRE ISLAND OTTAWA, ONTARIO



7-814-888-8888
119-360 Chaudière Street, Ottawa, ON K1P 3B8 CANADA

DREAM THEIA BLOCK 204A L
ZIBI ONTARIO, 315 PRIVE MIWATE,
CHAUDIÈRE ISLAND, OTTAWA, ONTARIO
ISSUED FOR ECA, FEBRUARY 03rd, 2023

City of Ottawa Project # : D07-12-22-0071
City of Ottawa Plan # : 18749

TITLE LOCK 2438 VERT ENG 3.0
 PRINT DATE: 2023/03/14 PAPER SIZE: A0
 PATH: Z:\Cma-C1\0101\Projects\A000991_Zib\Blok 7_Ottawa400_Drafting\400_Civic-1_topo.dwg / LAYOUT: C001_Topo

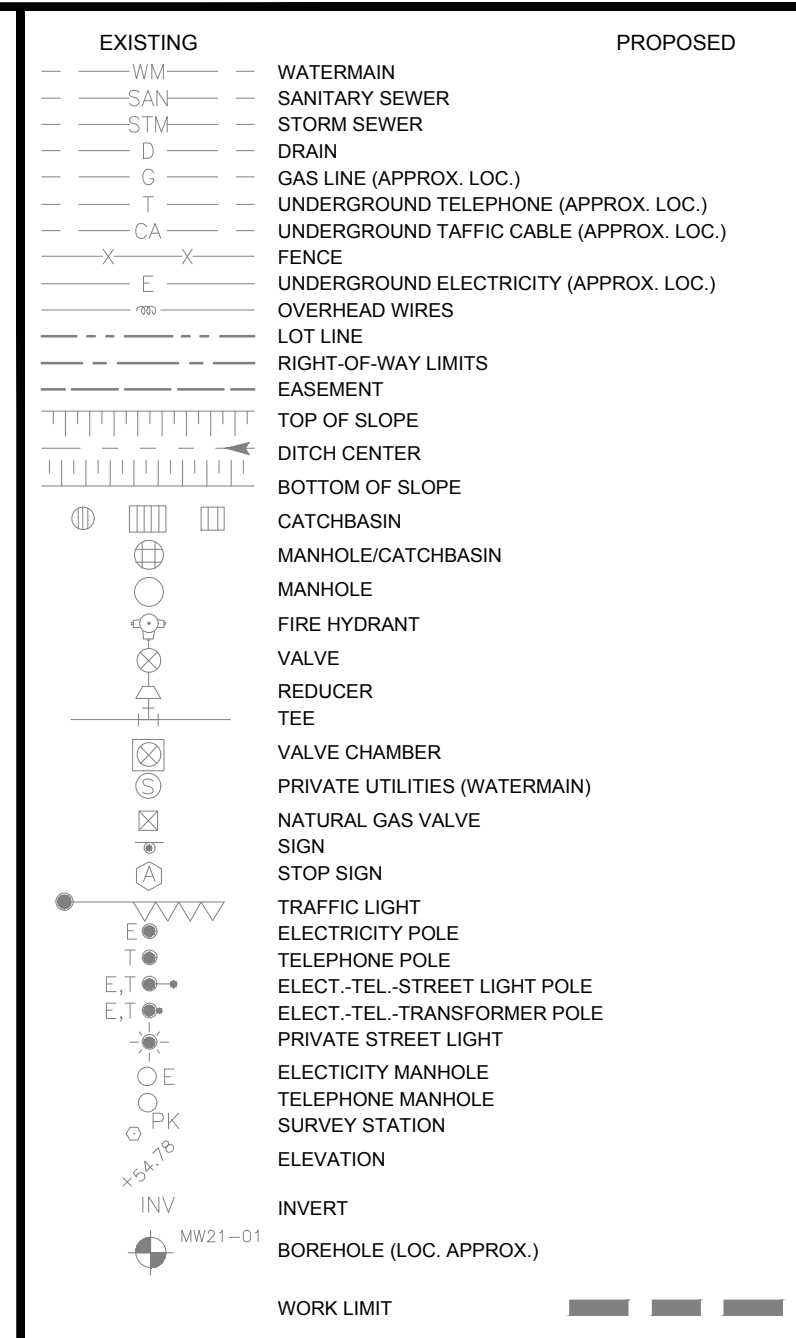
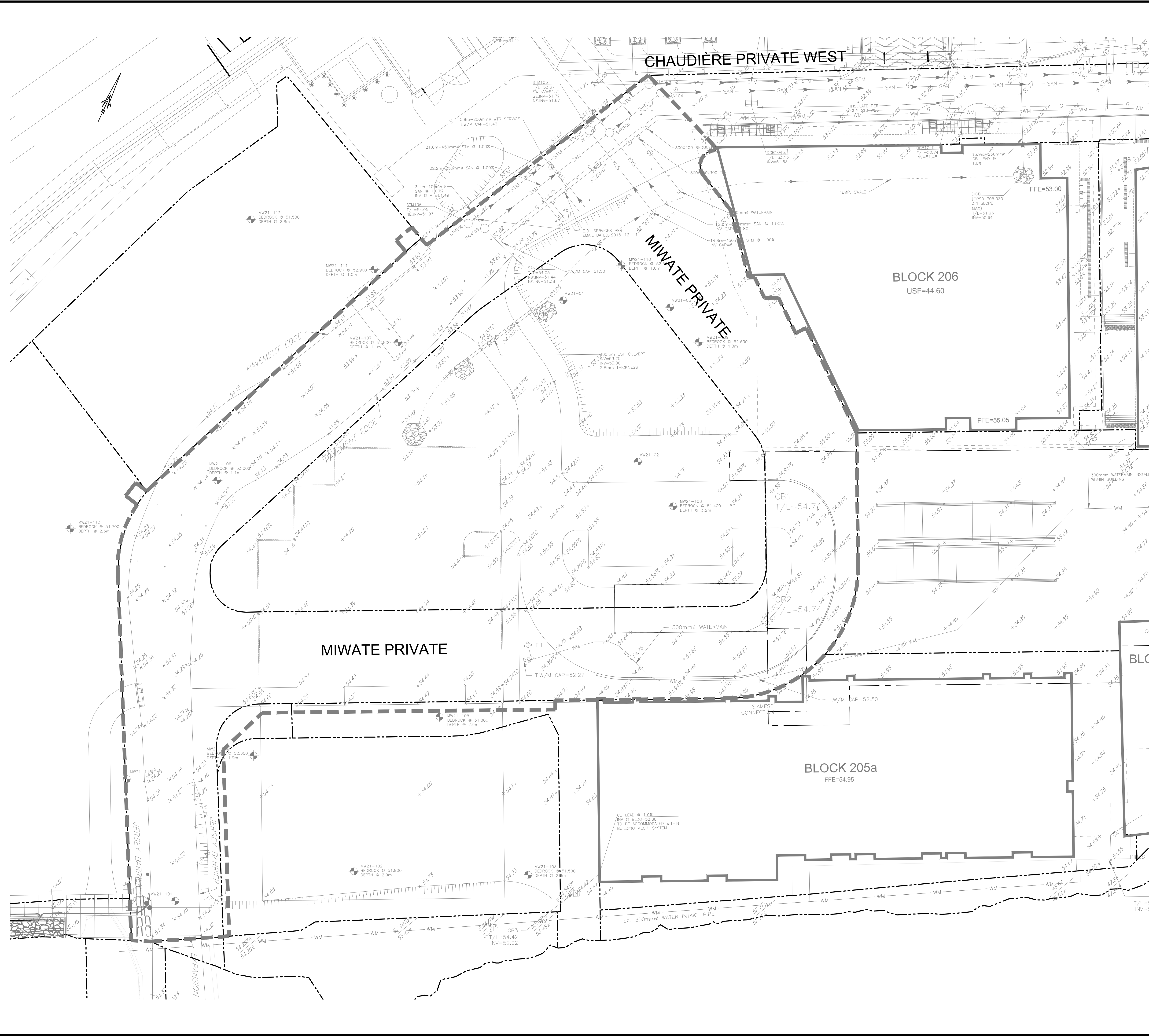

ABBREVIATIONS

STM	→	STORM
SAN	→	SANITARY
WM	→	WATERMAIN
WTR	→	WATER
INV	→	INVERT
MH	→	MANHOLE
CB	→	CATCHBASIN
TL	→	TOP OF LID
OBV	→	OBVERT
FFE	→	FINISHED FLOOR ELEVATION
BLDG	→	BUILDING
SERV	→	SERVICE

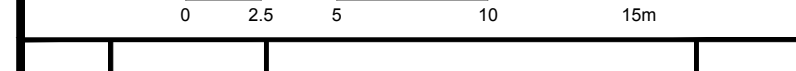

No.	Date	Description	By
4	FEB 03, 2023	ISSUED FOR ECA	A.C.
3	NOV 21, 2022	ISSUED FOR SITE PLAN APPLICATION	A.C.
2	AUG 31, 2022	ISSUED FOR SITE PLAN APPLICATION	A.C.
1	APR. 18, 2022	ISSUED FOR SITE PLAN APPLICATION	A.C.

STAMPS

DESIGNED BY	APPROVED BY
ENGINEER	



CLIENT:
DREAM UNLIMITED
 30 ADELAIDE STREET EAST
 SUITE 301
 TORONTO, ON, M5C 3H1
 613-219-2722
ZIBI (Project Address)
 310 Miwate Private
 OTTAWA, ONTARIO
 K1R 0E1

PROJECT NAME:
**ZIBI ONTARIO
 BLOCK 204
 315 PRIVE MIWATE PRIVATE,
 CHAUDIÈRE ISLAND
 OTTAWA, ONTARIO**

SHEET TITLE:
**TOPOGRAPHICAL
 SURVEY PLAN**

DISCIPLINE: CIVIL	SCALE: 1:250
DRAWN BY: S.C. POGGIOLI	DATE: 2022/03/14
DESIGNER: J. SALUVE	APPROVER: A. CHAUMONT
PROJECT NO.: A000991	DRAWING NO.: C001
SHEET NO.: 1 of 11	

TOPOGRAPHIC INFORMATION

- CHAUDIÈRE AND ALBERT ISLAND TOPOGRAPHIC INFORMATION PROVIDED BY FAIRHALL, MOFFATT & WOODLAND LIMITED, DATED JANUARY 15, 2019.
- BOOTH STREET/FLEET STREET/LOYD STREET/ALBERT STREET TOPOGRAPHIC INFORMATION PROVIDED BY STANTEC GEOMATICS LIMITED, DATED APRIL 20, 2018.
- TEMPORARY ROAD CHAUDIÈRE & ALBERT STREET TOPOGRAPHIC INFORMATION PROVIDED BY STANTEC GEOMATICS LIMITED, DATED AUGUST 08, 2019.

LEGAL INFORMATION

- LEGAL SURVEY PROVIDED BY STANTEC GEOMATICS LIMITED, DATED 2022

BENCH MARK

POINT	NORTHING	EASTING	ELEVATION	DESCRIPTION
10	5031271	365915.9320	54.3480	CP
85591	5031480	366018.9270	51.8200	BOLT
86037	5031454	366008.0430	52.0910	PKN
1000010	5031523	365993.0550	51.2040	MON 2018-007

NOTE OF CAUTION

THE GEODETIC COORDINATES OF EVERY ITEM INCLUDED AS PART OF THIS DOCUMENT ARE IN NAD83 - ORIGINAL / MTM - REFERENCE SYSTEM AND HAVE NO LEGAL VALUE. THE SITE LAYOUT MUST BE COMPLETED USING THE OFFICIAL BENCHMARKS OF AN ACCREDITED LAND SURVEYOR IN THE NAD83 - ORIGINAL / MTM - REFERENCE SYSTEM.

THE UNDERGROUND FEATURES AND INFORMATION THAT APPEAR ON THE DRAWINGS WERE OBTAINED FROM THE PUBLIC UTILITY COMPANIES AND/OR FROM THE CITY EACH RESPECTIVELY.

ALL INFORMATION UNDER THE LEGEND 'EXISTING' IS FOR INFORMATION ONLY. COMPLETE OR EXACT LOCATION AND ELEVATION OF UNDERGROUND SERVICES ARE NOT GUARANTEED.

CERTAIN UNDERGROUND FEATURES ON PRIVATE PROPERTY ARE NOT SHOWN ON THE CURRENT DRAWING.

ANYONE WHO PROCEEDS WITH EXCAVATION WORK SHALL VERIFY THE EXACT LOCATION OF ALL UNDERGROUND FEATURES, BY EXPLORATORY EXCAVATIONS, AND SHALL ASSUME FULL RESPONSIBILITY IF THERE IS ANY DAMAGE THAT OCCURS DURING WORK.

THE CONTRACTOR WILL HAVE THE RESPONSIBILITY AND THE OBLIGATION TO VALIDATE, BY EXPLORATORY EXCAVATION, THE SIZE OF THE PUBLIC UTILITIES UNDERGROUND SERVICES AND TO WARN THE ENGINEER OF ANY CONFLICT WITH THE PROJECTED WORK.

TITLEBLOCK 24x36 VERT ENG 3.0
PRINT DATE: 2023/03/14 PAPER SIZE: A0
PATH: Z:\Cma-C\1\0\1\Projects\A000931_Zib\Blok 7_Ottawa400_Drafting\60_Civic-2_Nores.dwg / LAYOUT: CO2D_Nores

GENERAL NOTES

1. GRADE CONTROL AND DRAINAGE - GENERAL

- 1.1. The Contractor must conform to all laws, codes, ordinances, and regulations adopted by federal, provincial or municipal government councils and government agencies, applying to work to be carried out.
- 1.2. Unless otherwise indicated, all materials and construction methods to be in accordance with the requirements of the latest edition of the City of Ottawa Design Guidelines, Ontario Provincial Standard Specifications and Drawings (OPSS and OPSD), the Ontario Ministry of Environment, Conservation and Parks (MECP), applicable Conservation Authorities, the municipal standard specifications and drawings, and all other governing authorities as they apply.
- 1.3. Wherever standards, laws and/or regulations are mentioned they refer to their current versions, modifications included.
- 1.4. The boreholes and test pits shown on the plan are for information purposes only. Their location on the plan is approximate. The Contractor must refer to the boreholes and test pit records to obtain information about observed stratigraphy on site.
- 1.5. The Contractor is responsible for obtaining all permits required to complete all works and bear cost of same, including road cut permit and water permit and their associated costs.
- 1.6. The Contractor is responsible for the coordination of his activities with others on site.
- 1.7. Submit copies of inspection and test reports to Owner's representative.
- 1.8. The location of existing underground municipal services and public utilities as shown on the plans are approximate. The Contractor must determine the exact location, size, material and elevation of all existing utilities (on-site and off-site) prior to any excavation work. Damage to any existing services and/or existing utilities during construction, whether or not shown on the drawings must be repaired by the Contractor at his own expense.
- 1.9. Site preparation includes clearing, grubbing, stripping of topsoil, demolition, removal of unsuitable materials, cut, fill and rough grading of all areas to receive finished surfaces.
- 1.10. N/A
- 1.11. Compaction must conform to the following requirements:
 - Exposed subgrade:
 - 95% Standard Proctor maximum dry density (SPMDD)
 - Granular Subbase foundations:
 - 99% Standard Proctor maximum dry density (SPMDD)
 - Granular Base foundations:
 - 99% Standard Proctor maximum dry density (SPMDD)
- 1.12. If groundwater is encountered during construction, dewatering of excavations could be required as per OPSS MUNI 518. It is assumed that groundwater may be controlled by sump and pumping methods. As required under the "Ontario Water Resources Act (OWRA)", the Contractor must register all water taking activities on Ontario's "Environmental Activity and Sector Registry (EASR)" if water taking exceeds 50,000 l/day, and obtain a "Permit to Take Water (PTTW)" if water taking exceeds 400,000 l/day. Furthermore, Contractor must provide all necessary measures required to ensure dewatering operations do not affect in any way the integrity of the existing surrounding buildings and must plan his work accordingly. Water Taking and Discharge Plan to be prepared by a Qualified Person as stipulated under O.Reg. 63/16.
- 1.13. Control disposal or runoff of water containing suspended materials or other harmful substances in accordance with local authority requirements and as follows:
 - 1.13.1. Provide flocculation tanks, settling basins, or other treatment facilities to remove suspended solids or other materials to within the required parameters of the receiving body before discharging to storm sewers, watercourses or drainage areas.
 - 1.13.2. Before discharging to storm sewers, watercourses or drainage areas, discharge water must be sampled and tested to ensure quality requirements in accordance with City of Ottawa Sewer Use By-Law No. 2003-514 and the MECP are adhered to. The Contractor is to perform all additional sampling and testing as required by City of Ottawa. All associated fees to be paid by the Contractor.
 - 1.13.3. Where water is not suitable for discharge into the adjacent storm sewers, watercourses or drainage areas it must be discharged into the on-site sanitary sewer collection system, or disposed off-site at an approved disposal facility.
- 1.13.4. Sanitary Sewer Discharge:
 - 1.13.4.1. When discharging to the sanitary sewer, the Contractor must obtain a Sanitary Sewer Agreement for Dewatering from the City of Ottawa in accordance with City of Ottawa Sewer Use By-Law No. 2003-514 and pay all associated fees.
 - 1.13.4.2. A copy of the signed Sanitary Sewer Agreement for Dewatering must be provided to the Owner's Representative in advance of dewatering and discharge.
 - 1.13.4.3. The Contractor must ensure all requirements of the Discharge Agreement are adhered to and all prerequisite requirements of the Agreement are in place prior to commencing dewatering.
 - 1.13.4.4. Provide flow meter and record discharge rate in accordance with City of Ottawa requirements.
 - 1.13.4.5. Dewatering discharge rate to sanitary sewer not to exceed rate specified by City.
 - 1.13.4.6. For off-site disposal of dewatering effluent, Contractor to provide Departmental Representative proof of receipt that dewatering effluent was received at a licensed landfill facility and pay all associated disposal fees.
 - 1.13.4.7. Contractor must provide name of proposed licensed disposal facility to Owner's Representative in advance of any dewatering waste leaving the site.
 - 1.13.4.8. Contractor is responsible for paying all costs associated with any water quality sampling and testing required.
- 1.14. The Contractor must maintain benchmarks and landmark references as is. Otherwise these references will be repositioned by a certified land surveyor at the Contractor's expense.
- 1.15. The Contractor is the only person in charge of safety on the building site. The Contractor is responsible for providing adequate protection of the workers, other personnel and the general public, protection of materials, as well as maintaining in good condition the completed works and works to be completed. The Contractor must supply, install and maintain an appropriate safety fence along the work perimeter until the work is complete.
 - The Contractor must provide at any time:
 - A sufficient number barriers, posts, guards and others to ensure safety.
 - Necessary conveniences for the completion of the work such as heating, lighting, ventilation, etc.
- 1.16. Temporary excavations in the overburden must be completed as per the requirements of the Occupational Health and Safety Act (OHS), O. Reg. 213/91, Part III - Excavations.
 - The side slopes of excavations in the soil and fill overburden materials should either be cut back at acceptable slopes or should be retained by shoring systems from the star of the excavation until the structure is backfilled.
 - The excavation side slopes above the groundwater level extending to a maximum depth of 3 m should be cut back at 1H:1V or flatter. The flatter slope is required for excavation below groundwater level. The subsurface soil is considered to be mainly a Type 2 and 3 soil according to the Occupational Health and Safety Act and Regulations for Construction Projects. Slopes in excess of 3 m in height should be periodically inspected by the geotechnical consultant in order to detect if the slopes are exhibiting signs of distress.
- 1.17. The Contractor must pace deliveries and removals in order to minimize and control stockpiles.
- 1.18. Excavated soil must not be stockpiled directly at the top of excavations and heavy equipment kept away from the excavation sides.
- 1.19. Cleanliness on the site:
 - The Contractor must clean roadways at his own cost as directed by the Owner's representative;
 - All site roads and walkways to and from the construction zone must be kept clean at all times, from mud, dirt, granular material, debris, etc.;
 - The Contractor must leave the work area clean at the end of each day;
 - Materials and equipment must be laid out in an organized and safe manner;
 - All material, equipment and temporary structures which are no longer necessary for the execution of the Contract must be removed from the site;
 - If required the Contractor must use screens, bulkheads, or any other recognized means in order to reduce noise, dust, interference, obstruction, etc., in conformity with the requirements of the provincial and municipal authorities having jurisdiction.

- 1.20. During the construction period the Contractor is responsible for installing and maintaining temporary traffic signage, including traffic signs, traffic markings and temporary traffic lights, and flagmen, as required by the Owner, the Consultant, the Municipality, and other governing authorities.
- 1.21. The Contractor must control surface runoff from precipitation during construction.
- 1.22. The Contractor must ensure the following mitigation measures are implemented in order to reduce the risk of ground contamination from petroleum products:
 - The list of persons and agencies to contact in the event of an emergency must be posted in plain sight on the work site for the duration of the construction period.
 - Machinery must be clean and kept clean to limit any grease or oil deposits inside the work area.
 - Frequent inspections must be performed to detect any oil, fuel, grease or other leaks. If a leak is detected, the necessary corrective action must be taken immediately.
 - An emergency kit for the recovery of petroleum products must be kept on site at all times.
 - The kit must include at least 30 m of absorbent booms, a box of absorbent pads and solid absorbent material (powder or granules). The kit must be stored near the location of work and machinery, and kept within easy reach at all times to ensure a rapid response;
 - In the event of a spill the Contractor must immediately report to the Spills Action Centre of the MECP at 1-800-268-6960. Hydrocarbons and contaminated soils will be recovered by a specialized firm.
- 1.23. The Contractor must ensure the following measures are implemented regarding the handling of concrete:
 - Concrete should either be mixed away from the site or should be prepared on paved surfaces if only small quantities are required (i.e. minor repairs).
 - Excess concrete must be disposed off-site at a location that has been approved by regulatory requirements;
 - The washing of concrete trucks and other equipment used for mixing concrete should not be carried out within 30 m of a watercourse or wetland and should take place outside of the work site.
 - All concrete trucks should collect their wash water and recycle it back into their trucks for disposal off-site at a location meeting all regulatory requirements.
- 2. DEMOLITION AND REMOVALS
 - 2.1. The Contractor must visit the premises in order to be fully aware of existing conditions on site, including all elements to be removed and demolished. No claim will be accepted due to a poor evaluation of the work to be completed.
 - 2.2. The Contractor must protect and maintain in service the existing works which must remain in place. If they are damaged, the Contractor must immediately make the replacements and necessary repairs to the satisfaction of the Owner's representative and without additional expense to the Owner.
 - 2.3. The Contractor must perform the necessary clearing and grubbing in accordance with OPSS MUNI 201.
 - 2.4. The Contractor must carry out necessary saw cuts even if they are not shown on the drawings.
 - 2.5. The Contractor must entirely remove the demolition wreckage from the construction site in accordance with the requirements of the MECP and in accordance with OPSS MUNI 180 and OPSS MUNI 510.
 - The Contractor must discard recyclable demolition materials in collaboration with a regional recycling company. The Contractor must be able to provide proof, upon request, that the materials were properly recycled and that the chosen recycling company is recognized in the recycling field.
 - All other demolition materials must be disposed off-site at authorized licensed landfills and in conformity with the applicable laws and regulations. The Contractor must be able to provide, upon request, copies of the disposal tickets.
 - 2.6. The Contractor is responsible for locating existing public utilities and (if required) submit a request for the interruption of public utility services, such as gas, telephone, power, cable, sewers, watermain, etc.
 - 2.7. The Contractor must conduct all removals required to make the work complete.
 - 2.8. Unless otherwise specified, all materials, products and others coming from the demolition belong to the Contractor.
 - 2.9. Surfaces and works located outside of the construction work limit must be reinstated as they were before beginning of work.
- 3. GENERAL SUBGRADE PREPARATION
 - 3.1. Earth removal must be inspected by an experienced Geotechnical Engineer to ensure that all unsuitable materials are removed prior to the placement of fill, including concrete and/or others, and to confirm the compaction degree and condition of the founding soils. All unsuitable materials must be hauled off site and disposed as per provincial and municipal regulations.
 - 3.2. Subgrade must be approved by experienced geotechnical personnel before proceeding with placement of fill.
 - 3.3. All granular fill must be placed in maximum 300 mm thick loose lifts and compacted using suitable methods as per the requirements.
 - 3.4. If soft spots develop in the subgrade during compaction or due to construction traffic, the affected areas should be excavated and replaced with OPSS Granular B Type II material.
 - 3.5. If contaminated material is encountered during the work, the Contractor must dispose off-site all materials from the contaminated area in accordance with the requirements of the MECP and OPSS MUNI 180. Prior to the start of work the Contractor must provide the name and location of landfill(s) where the contaminated materials will be disposed to the Consultant. The Contractor must obtain from the landfill Owner documents confirming that he has the right to accept the contaminated material. During the work, the contractor must provide the Consultant copies of all check-in receipts issued by the landfill Owner.
 - 3.6. The Contractor is responsible for providing a confirmation that the imported material used as subgrade fill is free of any contaminants such as Petroleum Hydrocarbons (C₁₀-C₂₀), PAH (Polycyclic Aromatic Hydrocarbons), MAH (Monocyclic Aromatic Hydrocarbons) and metals like mercury, silver, arsenic, cadmium, cobalt, chromium, copper, tin, manganese, molybdenum, nickel, lead and zinc.
- 4. EXCAVATION AND BACKFILL
 - 4.1. Subgrade preparation must be completed as per Section "3.0 General Subgrade Preparation".
 - 4.2. The management of excess materials to comply with OPSS MUNI 180.
 - 4.3. Topsoil and deleterious fill, such as those containing organic materials, must be stripped from under any buildings, paved areas, pipe bedding, and other settlement sensitive structures.
 - 4.4. Due to the relatively shallow depth of the bedrock surface and the anticipated founding level for the proposed building, all existing overburden material must be excavated from within the proposed building footprint.
 - 4.5. Existing foundation walls and other construction debris must be entirely removed from within the building perimeter. Under paved areas, existing construction remnants, such as foundation walls, must be excavated to a minimum of 1 m below final grade.
 - 4.6. Fill used for grading beneath the building areas must consist, unless otherwise specified, of clean imported granular fill, such as Ontario Provincial Standard Specifications (OPSS) Granular A or Granular B Type II. This material must be tested and approved prior to delivery to the site. The fill must be placed in lifts no greater than 300 mm thick and compacted using suitable compaction equipment for the lift thickness. Fill placed beneath the building must be compacted to at least 98% of its standard Proctor maximum dry density (SPMDD).
 - 4.7. Non-specified existing fill along with site-excavated soil can be used as general landscaping fill where settlement of the ground surface is of minor concern. These materials should be spread in thin lifts and at least compacted by the tracks of the spreading equipment to minimize voids. If these materials are to be used to build up the subgrade level for areas to be paved, they should be compacted in thin lifts to a minimum density of 95% of their respective SPMDD.
 - 4.8. Non-specified existing fill and site-excavated soils are not suitable for use as backfill against foundation walls unless a composite drainage blanket connected to a perimeter drainage system is provided.
 - 4.9. Based on the bedrock encountered in the area, it is expected that line-drilling in conjunction with hoe-ramping or controlled blasting may be required to remove the bedrock. In areas of weathered bedrock and where only a small quantity of bedrock is to be removed, bedrock removal may be possible by hoe-ramping.
 - 4.10. Rock excavation must conform to OPSS 403.MUNI / City of Ottawa Special Provision F-4031 and to all laws, codes, ordinances and regulations adopted by federal, provincial and municipal government councils and government agencies, applying to the work to be carried out.

- 4.11. Prior to considering blasting operations, the effects on the existing services, buildings and other structures must be addressed. A pre-blast or construction survey located in proximity of the blasting operations must be conducted prior to commencing construction. The extent of the survey must be determined by the blasting consultant and sufficient to respond to any inquiries/claims related to the blasting operations. As a general guideline, peak particle velocity (measured at the structures) must not exceed 25 mm/s during the blasting program to reduce the risks of damage to the existing structures. The blasting operations should be planned and conducted under the supervision of a licensed professional engineer who is an experienced blasting consultant.
- 4.12. Excavation side slopes in sound bedrock may be completed with almost vertical side walls. As required, obtain confirmation from a geotechnical engineer for safety.
- 4.13. Construction operations could cause vibrations, and possibly, sources of nuisance to the community. Therefore, means to reduce the vibration levels as much as possible must be incorporated in the construction operations to maintain a cooperative environment with the residents.
- 4.14. The following construction equipments could cause vibrations: piling equipment, hoe ram, compactor, dozer, crane, truck traffic, etc. Vibrations, caused by blasting or construction operations could cause detrimental vibrations on the adjoining buildings and structures. Therefore, it is recommended that all vibrations be limited.
- 4.15. Two parameters determine the recommended vibration limit, the maximum peak particle velocity and the frequency. For low frequency vibrations, the maximum allowable peak particle velocity is less than that for high frequency vibrations. As a guideline, the peak particle velocity should be less than 15 mm/s between frequencies of 4 to 12 Hz, and 50 mm/s above a frequency of 40 Hz (interpolate between 12 and 40 Hz). These guidelines are for current construction standards.
- 4.16. Considering there are several sensitive buildings in close proximity to the subject site, consideration to lowering these guidelines is recommended. These guidelines are above perceptible human level and, in some cases, could be very disturbing to some people. A pre-construction survey is therefore required to minimize the risks of claims during or following the construction of the proposed building.

SERVICING NOTES

1. MUNICIPAL SERVICES - GENERAL

- 1.1. Unless otherwise indicated, all materials and construction methods to be in accordance with the requirements of the latest edition of the Ontario Provincial Standard Specifications and Drawings (OPSS and OPSD), the Ontario Ministry of Environment, Conservation and Parks (MECP), applicable Conservation Authorities, the municipal standard specifications and drawings, and all other governing authorities as they apply.
- 1.2. Wherever standards, laws and/or regulations are mentioned they refer to their current versions, modifications included.
- 1.3. The boreholes and test pits shown on the plan are for information purposes only. Their location on the plan is approximate. The Contractor must refer to the boreholes and test pit records to obtain information about observed stratigraphy on site.
- 1.4. The location of existing underground municipal services and public utilities as shown on the plans are approximate. The Contractor must determine the exact location, size, material and elevation of all existing utilities (on-site and off-site) prior to any excavation work. Damage to any existing services and/or existing utilities during construction, whether or not shown on the drawings must be repaired by the Contractor at his own expense.
- 1.5. The Contractor is responsible for obtaining all permits required to complete all works and bear cost of same, including water permit and associated costs.
- 1.6. The Contractor is responsible for the coordination of his activities with others on-site.
- 1.7. Terminate and plug all service connections at 1.0 meter from edge of the building.
- 1.8. The Contractor must complete compaction as per OPSS MUNI 501 and note the following requirements for service trenching:

MATERIALS	COMPACTION
Pipe bedding	95% Standard Proctor Maximum Dry Density
Trench backfill and pipe cover	95% Standard Proctor Maximum Dry Density
- 1.9. The Contractor is responsible for making or arranging all connections to the existing sewers as per municipal requirements. Prior to connection, the Contractor must provide, to the Engineer and the City for approval, all test results performed on the internal services. Test results must include C.C.T.V. inspection of sewers, infiltration/exfiltration tests for sewers and manholes, deformation tests of sewers, watermain hydrostatic leakage test, flushing and disinfecting operations, and bacteriological water analysis.
- 1.10. Advise the City Public Works at least 72 hours in advance before any connection to the City services. Coordinate with City as required.
- 1.11. The Contractor must determine the exact invert (geodetic elevation), diameter and construction material of the existing conduits at the proposed connections. He must also carry out, if necessary, exploratory excavations in order to determine the exact location and inverts of existing duct banks. This information must immediately be provided to the Engineer prior to start undertaking any municipal services work and a 48 hour period must be allocated to the Engineer for design review.
- 1.12. The Contractor is responsible for all excavation, backfill and reinstatement of all areas disturbed during construction to existing conditions or better and all associated works to the satisfaction of the Engineer and municipal authorities.
 - Asphalt reinstatement must be in accordance with OPSS MUNI 310.
 - Landscape areas to be reinstated with 150 mm of topsoil and sod in accordance with OPSS MUNI 802 and OPSS MUNI 803.
- 1.13. It is recommended that a trench box be used at all times to protect personnel working in trenches with steep or vertical sides. Services are expected to be installed by "cut and cover" methods and excavations should not remain open for extended periods of time.
- 1.14. The pipe bedding for sewer and water pipes must consist of at least 150 mm of OPSS Granular A material. The material must be placed in maximum 300 mm thick lifts and compacted to a minimum of 95% of its SPMDD. The bedding material should extend at least to the spring line of the pipe.
- 1.15. The cover material, which must consist of OPSS Granular A, will extend from the spring line of the pipe to at least 300 mm above the crown of the pipe. The material must be placed in maximum 300 mm thick loose lifts and compacted to a minimum of 95% of its SPMDD.
- 1.16. Where hard surface areas are considered above the trench backfill, the trench backfill material within the frost zone (about 1.8 m below finished grade) must match the soils exposed at the trench walls to minimize differential frost heaving. The trench backfill must be placed in maximum 300 mm thick loose lifts and compacted to a minimum of 95% of the material's SPMDD.
- 1.17. Dewatering of pipeline, utility and associated structure in rock excavations to be completed as per OPSS MUNI 403.
- 1.18. Trenching, backfilling and compacting must conform to OPSS MUNI 401.

2. WATERMAIN

- 2.1. Watermain, water service connections and associated appurtenances must be constructed in accordance with the Ontario Provincial Standard Specifications / City of Ottawa Standards Specifications / Ministry of Environment and Climate Change Requirements. Specifically watermain must conform to OPSS MUNI 441.
- 2.2. Watermain must be constructed as per OPSS MUNI 441 and specifically OPSS 802.010 for earth excavations and 802.013 for rock excavation. Bedding and cover material to be OPSS Granular 'A' compacted to 95% Standard Proctor Maximum Dry Density.
- 2.3. Watermain pipe materials must be class 150 PVC DR 18 or approved equivalent, unless otherwise shown on the Drawings. Materials must conform to OPSS 441.
- 2.4. All watermain must be installed with a minimum of 2.40 meters cover from finished grade. Where a minimum of 2.40 meters cover is not reached, thermal insulation is required as per City of Ottawa Details W22 and W23.
- 2.5. Watermain service connections must be installed a minimum of 2.40 meters from any catch-basin, manhole or object that may contribute to freezing. Thermal insulation must be installed as per City of Ottawa Details W22 and W23 where 2.40 meters of separation cannot be achieved.
- 2.6. Cathodic protection (if required) must be installed as per City of Ottawa Details W40 and W42.
- 2.7. Thrust block and restraints must be as per City of Ottawa Details W25.3, W25.4, W25.5 and W25.6.
- 2.8. Valves to be installed as per OPSS 441 and conform to the following:
 - All valves must open in a counter clockwise direction;
 - Designed for cold water working pressure of 1035 kPa;
 - Types must be one of the following:
 - Valves less than 75 mm to be brass or bronze gate valves;
 - Valves greater than or equal to 75 mm, and less than or equal to 300 mm, to be cast or ductile iron gate valves;
 - Valves greater than 300 mm up to and including 500 mm to be gate or butterfly valves;
 - Valves greater than 500 mm to be butterfly valves.
- 2.9. A continuous 12 gauge copper tracer wire must be installed over all watermain. Tracer wire must be tied to all fire hydrants.
- 2.10. Valve box assembly to be as per City of Ottawa Detail W24.
- 2.11. When a watermain pipe crosses a sewer pipe, installation must be as per City of Ottawa Detail W25.2.
- 2.12. Watermain must be thoroughly flushed and cleaned to remove all dirt and debris prior to the disinfection process.
- 2.13. All watermain must be hydrostatically and bacteriologically tested as per provincial and municipal regulations. It is the Contractor's responsibility to ensure that all requirements are followed.
- 2.14. The Contractor must make arrangements with and give a minimum of 24 hours' notice to the City for the dosing off of necessary valves in the water distribution system. The DREAM representative will operate valves at the time of tie-ins, etc. at no expense to the Contractor under normal conditions; however the Contractor will be responsible for all costs associated with emergency shutdowns if they occur outside of the normal working hours of the DREAM representative (Monday to Friday, 7:00 a.m. to 5:00 p.m.).

- 2.15. Hydrostatic testing to be completed as per OPSS 441.07.24. Testing must be completed under the supervision of the Contract Administrator. The test section will be either a section between valves or the completed watermain. Test pressure to be 1035 kPa.
- 2.16. Flushing and Disinfecting to be completed as per OPSS 441.07.25 under the supervision of the Contract Administrator.
- 2.17. The Contractor must obtain a permit from the City before using an existing fire hydrant located within the City's territory.
- 2.18. The Contractor must coordinate and pay the cost of connection, inspection and disinfection by municipal personnel.
- 2.19. Contractor must coordinate the supply and installation of water meter and remote water meter for the building with the mechanical engineer.
- 2.20. All phases of Zibi Ontario serviced and billed by meter chamber per city standard W32. Individual sub-metering provided based on future condominium requirements.

3. STORM SEWER

- 3.1. Storm sewers, laterals and storm service connections must be constructed in accordance with the Ontario Provincial Standard Specifications / City of Ottawa Standards Specifications / Ministry of Environment and Climate Change Requirements. Specifically storm sewers must conform to OPSS MUNI 410.
- 3.2. PVC storm sewer material to conform to OPSS MUNI 1841. PVC storm sewers to be installed as per OPSS 802.010 for earth excavation and 802.013 for rock excavation. Bedding and cover material to be OPSS Granular 'A'.
- 3.3. The allowable deflected pipe diameter when using flexible pipe is as follows:
 - Pipes 100 to 750 mm: 7.5% of the base inside diameter of the pipe
 - Greater than 750 mm: 5.0% of the base inside diameter of the pipe
- 3.4. Final backfill material for storm sewers must be approved native material or select subgrade material in conformance with OPSS MUNI 212.
- 3.5. Storm sewer pipes must be type PVC SDR-35, unless noted otherwise on the drawings.
- 3.6. All storm sewers to be C.C.T.V. inspected by the Contractor as per OPSS MUNI 409. Report must be provided to the Engineer in two (2) copies and the C.C.T.V. inspection in DVD format only.
- 3.7. Storm manholes, manhole/catchbasins, catchbasins, ditch inlets and valve chambers to be installed as per OPSS 407.
- 3.8. Adjustment or rebuilding of manholes, manhole/catchbasins, catchbasins, ditch inlets and valve chambers to be completed as per OPSS 408 / City of Ottawa Special Provisions F-4800 and F-4081.
- 3.9. Excavating, backfilling, and compacting for manholes, manhole/catchbasins, catchbasins, ditch inlets and valve chambers to be completed as per OPSS 402.
- 3.10. Storm manhole, manhole/catchbasin and catchbasin excavations to be backfilled with OPSS Granular 'B' compacted to 99% Standard Proctor Maximum Dry Density (SPMDD). Joints between sections must be wrapped in a non-woven geotextile.
- 3.11. Storm manholes and manhole/catchbasins to be as per OPSS 701.010 and must be equipped with safety platform as per OPSS 404.020 when exceeding 5.0 m to the lowest invert.
- 3.12. Storm manhole frame and cover to be as per OPSS 401.010 Type 'A' closed cover.
- 3.13. A maintenance hole drop structure tee is to be used as per OPSS 1003.010 when the drop from the inlet invert to the outlet invert is greater than 600 mm and less than 1200 mm. A drop structure wye is to be used as per OPSS 1003.020 when the drop exceeds 1200 mm.
- 3.14. Storm service connections to rigid main sewer pipe to be as per City of Ottawa Detail S11. Connections to flexible main sewer pipe to be as per City of Ottawa Detail S11.1.
- 3.15. When a minimum cover of 1.8 meters is not reached, frost protection is required.
- 3.16. For building roof drain sizes and location refer to architectural and mechanical drawings.
- 3.17. For insulation of storm sewer, refer to city of Ottawa detail W22 and use a value of 1.5m instead of 2.4m to figure out thickness of board insulation.

4. SANITARY SEWER

- 4.1. Sanitary sewers, laterals and service connections must be constructed in accordance with the Ontario Provincial Standard Specifications / City of Ottawa Standards Specifications / Ministry of Environment and Climate Change Requirements. Specifically sanitary sewers must conform to OPSS MUNI 410.
- 4.2. PVC sanitary sewer pipe material to type PVC SDR-35, conforming to OPSS MUNI 1841. PVC sanitary sewers to be installed as per OPSS 802.010 for earth excavation and 802.013 for rock excavation. Bedding and cover material to be OPSS Granular 'A'.
- 4.3. The allowable deflected pipe diameter when using flexible pipe is as follows:
 - Pipes 100 to 750 mm: 7.5% of the base inside diameter of the pipe
 - Greater than 750 mm: 5.0% of the base inside diameter of the pipe
- 4.4. Final backfill material for sanitary sewers must be approved native material or select subgrade material in conformance with OPSS MUNI 212.
- 4.5. All sanitary sewers to be C.C.T.V. inspected by the Contractor as per OPSS MUNI 409. Report must be provided to the Engineer in two (2) copies and the C.C.T.V. inspection in DVD format only.
- 4.6. Sanitary manholes to be installed as per OPSS 407.
- 4.7. Adjustment or rebuilding of sanitary manholes to be completed as per OPSS 408.
- 4.8. Excavating, backfilling, and compacting for sanitary manholes to be completed as per OPSS MUNI 402.
- 4.9. Sanitary manholes to be backfilled with OPSS Granular 'B' compacted to 99% Standard Proctor Maximum Dry Density (SPMDD). Joints between sections must be wrapped in a non-woven geotextile.
- 4.10. Sanitary manholes to be as per OPSS 701.010 and must be equipped with safety platform as per OPSS 404.020 when exceeding 5.0 m to the lowest invert.
- 4.11. Sanitary manhole frame and cover to be as per OPSS 401.010 Type 'A' closed cover.
- 4.12. A maintenance hole drop structure tee is to be used as per OPSS 1003.010 when the drop from the inlet invert to the outlet invert is greater than 600 mm and less than 1200 mm. A drop structure wye is to be used as per OPSS 1003.020 when the drop exceeds 1200 mm.
- 4.13. Sanitary service connections to rigid main sewer pipe to be as per City of Ottawa Detail S11. Connections to flexible main sewer pipe to be as per City of Ottawa Detail S11.1.
- 4.14. When a minimum cover of 1.8 meters is not reached, frost protection is required.
- 4.15. Benching is required inside the concrete bottom of sanitary manholes as per OPSS 701.021.

No.	Date	Description	By
4	FEB 03, 2023	ISSUED FOR ECA	A.C.
3	NOV 21, 2022	ISSUED FOR SITE PLAN APPLICATION	A.C.
2	AUG 31, 2022	ISSUED FOR SITE PLAN APPLICATION	A.C.
1	APR. 18, 2022	ISSUED FOR SITE PLAN APPLICATION	A.C.

STAMPS:

DESIGNED BY: [Signature]
APPROVED BY: [Signature]

ENGINEER:

CLIENT:
DREAM UNLIMITED
30 ADELAIDE STREET EAST
SUITE 301
TORONTO, ON, M5C 3H1
613-219-2722
ZIBI (Project Address)
310 Mivatte Private
OTTAWA, ONTARIO
K1R 0E1

PROJECT NAME:
**ZIBI ONTARIO
BLOCK 204
315 PRIVE MIWATE PRIVATE,
CHAUDREY ISLAND
OTTAWA, ONTARIO**

SHEET TITLE:
NOTES PLAN

DISCIPLINE:
CIVIL

DRAWER: S.C. POGGIOLI	SCALE:
DESIGNER: J.SAUVÉ	DATE: 2022/03/14
APPROVER: A.CHAUMONT	APPROVER: A.CHAUMONT
PROJECT NO: A000931	DRAWING NO.:
SHEET NO: 2 of 11	C002

TITLE: LOCK 24328 VERT ENG 3.0
 PRINT DATE: 2023/03/14 PAPER SIZE: A0
 PATH: Z:\Cma-C1\0101\Projects\A000931_2\B1\Block 7_Ottawa400_Drafting\60_Civic-3_Sediment&Erosion.dwg LAYOUT: C003_SEC

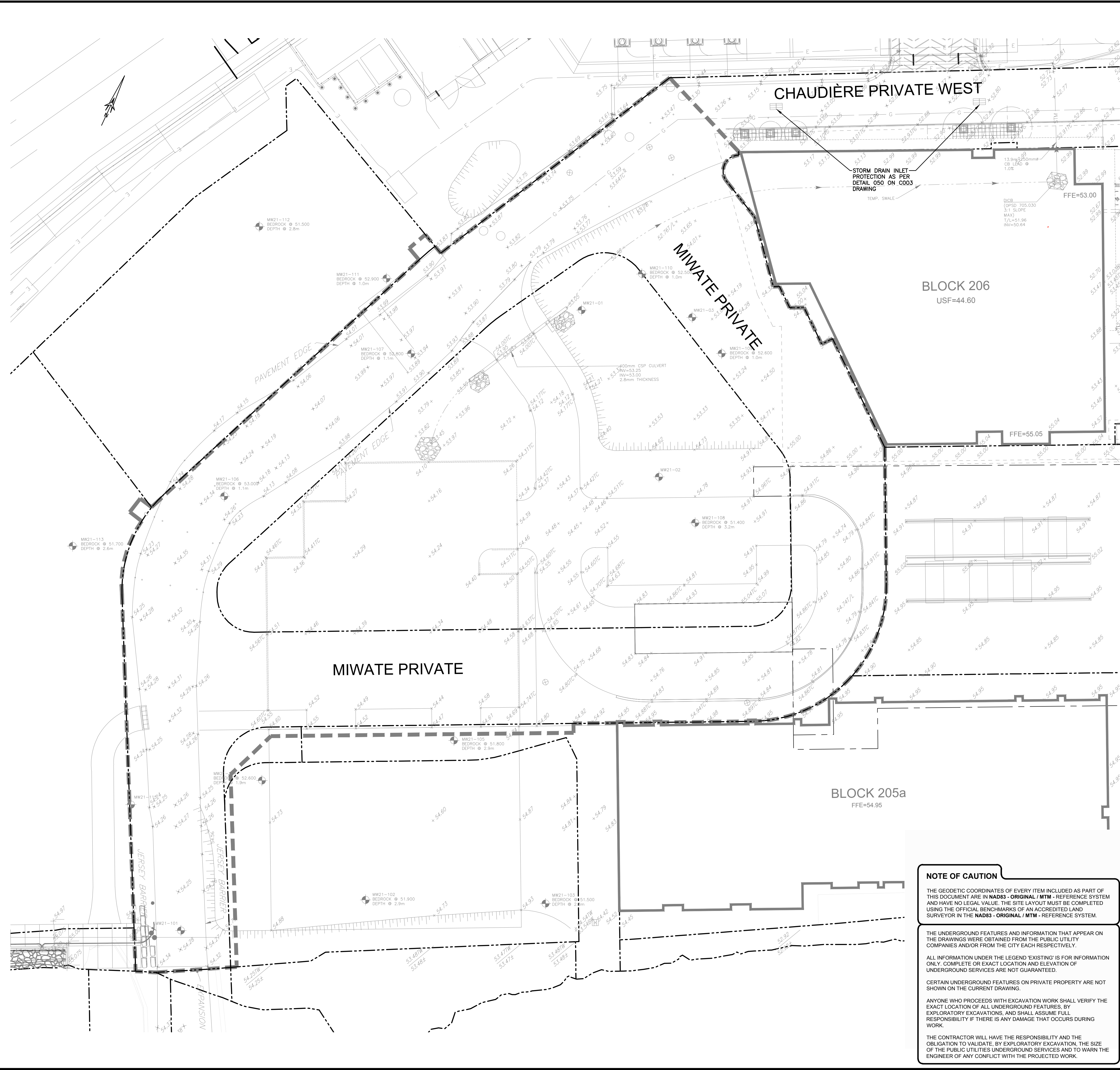

CHAUDIÈRE PRIVATE WEST

STORM DRAIN INLET PROTECTION AS PER DETAIL 050 ON C003 DRAWING

BLOCK 206
USF=44.60

MIWATE PRIVATE

BLOCK 205a
FFE=54.95

NOTE OF CAUTION

THE GEODETIC COORDINATES OF EVERY ITEM INCLUDED AS PART OF THIS DOCUMENT ARE IN NAD83 - ORIGINAL / MTM - REFERENCE SYSTEM AND HAVE NO LEGAL VALUE. THE SITE LAYOUT MUST BE COMPLETED USING THE OFFICIAL BENCHMARKS OF AN ACCREDITED LAND SURVEYOR IN THE NAD83 - ORIGINAL / MTM - REFERENCE SYSTEM.

THE UNDERGROUND FEATURES AND INFORMATION THAT APPEAR ON THE DRAWINGS WERE OBTAINED FROM THE PUBLIC UTILITY COMPANIES AND/OR FROM THE CITY EACH RESPECTIVELY.

ALL INFORMATION UNDER THE LEGEND 'EXISTING' IS FOR INFORMATION ONLY. COMPLETE OR EXACT LOCATION AND ELEVATION OF UNDERGROUND SERVICES ARE NOT GUARANTEED.

CERTAIN UNDERGROUND FEATURES ON PRIVATE PROPERTY ARE NOT SHOWN ON THE CURRENT DRAWING.

ANYONE WHO PROCEEDS WITH EXCAVATION WORK SHALL VERIFY THE EXACT LOCATION OF ALL UNDERGROUND FEATURES, BY EXPLORATORY EXCAVATIONS, AND SHALL ASSUME FULL RESPONSIBILITY IF THERE IS ANY DAMAGE THAT OCCURS DURING WORK.

THE CONTRACTOR WILL HAVE THE RESPONSIBILITY AND THE OBLIGATION TO VALIDATE, BY EXPLORATORY EXCAVATION, THE SIZE OF THE PUBLIC UTILITIES UNDERGROUND SERVICES AND TO WARN THE ENGINEER OF ANY CONFLICT WITH THE PROJECTED WORK.

- 1. SEDIMENT AND EROSION CONTROL**
- The contractor shall implement best management practices to provide for protection of the area drainage system and the receiving watercourse. During construction activities the contractor acknowledges that failure to implement appropriate erosion and sediment control measures may be subject to penalties imposed by any applicable regulatory agency.
 - Unless otherwise indicated, all materials and construction methods to be in accordance with the requirements of the latest edition of the Ontario Provincial Standard Specifications and Drawings (OPSS and OPSD), the Ontario Ministry of Environment, Conservation and Parks (MECP), applicable Conservation authorities, the municipal standard specifications and drawings, and all other governing authorities as they apply.
 - Wherever standards, laws and/or regulations are mentioned they refer to their current versions, modifications included.
 - Specifically, sediment and erosion control measures to be constructed as per OPSS MUNI 805.
 - The Contractor must implement best management practices and provide adequate sediment and erosion control measures during construction:
 - Prevent soil erosion which can result from stormwater runoff or wind erosion during construction;
 - Prevent sediment deposits in the storm sewer and/or collecting streams and;
 - Prevent air pollution from dust and particulate matter.
 - Provisions must be made for sediment and erosion control measures prior to stripping the site of vegetation and other deleterious materials. Measures such as phase stripping, vegetation buffer zones, silt fences, straw bales, sediment traps/basins, rock checks, etc. must be constructed and maintained in order to control sediment, as required by the provincial and municipal governing authorities.
 - The Contractor must set up the measures shown on the plan, inspect them frequently and clean and repair or replace the deteriorated structures.
 - When the sediment and erosion control measures have to be removed in order to complete a portion of the work, these same measures must be reinstated.
 - When storing soil on site in piles the Contractor must cover each pile with tarps, straw or a geotextile fabric to avoid fine particle transport by wind and/or streaming rain water.
 - During the construction period, sediment capture silt sacks or filter cloths must be installed and maintained between the frame and cover of all catchbasins and catchbasin/manholes to minimize sediments entering the storm sewer system. All landscaping areas must be completed prior to the removal of the silt sacks or filter cloths.
 - The light duty silt fence barrier must be installed as per OPSD 219.110.
 - At all times the Contractor must maintain the municipal access roads clean and free of sediments. When cleaning the access roads, the Contractor must take the necessary precautions to clear the surfaces covered with sediment prior to cleaning with water.
 - For dust control, Contractor to apply calcium chloride (Type 1 - OPSS 2501 and CAN/CSB-15-1) and water with equipment approved by the Owner's representative at rate in accordance to OPSS MUNI 506 when directed by Owner's representative.
 - At the end of the construction period, the Contractor is responsible for removal of the temporary sediment and erosion control measures and reconditioning the affected areas.
 - This plan is a "Living Document" which may be revised in the event that the control measures are not sufficient.

EXISTING

- WM WATERMAIN
- SAN SANITARY SEWER
- STW STORM SEWER
- D DRAIN
- G GAS LINE (APPROX. LOC.)
- T UNDERGROUND TELEPHONE (APPROX. LOC.)
- FC UNDERGROUND TRAFFIC CABLE (APPROX. LOC.)
- F FENCE
- E UNDERGROUND ELECTRICITY (APPROX. LOC.)
- OVERHEAD WIRES
- LOT LINE
- RIGHT-OF-WAY LIMITS
- EASEMENT
- TOP OF SLOPE
- DITCH CENTER
- BOTTOM OF SLOPE
- CATCHBASIN
- MANHOLE/CATCHBASIN
- MANHOLE
- FIRE HYDRANT
- VALVE
- REDUCER
- TEE
- VALVE CHAMBER
- PRIVATE UTILITIES (WATERMAIN)
- NATURAL GAS VALVE
- SIEN
- STOP SIGN
- TRAFFIC LIGHT
- ELECTRICITY POLE
- TELEPHONE POLE
- ELECT. TEL. STREET LIGHT POLE
- ELECT.-TEL.-TRANSFORMER POLE
- PRIVATE STREET LIGHT
- ELECTRICITY MANHOLE
- TELEPHONE MANHOLE
- SURVEY STATION
- ELEVATION

PROPOSED

- MW21-01 BOREHOLE (LOC. APPROX.)
- WORK LIMIT

ABBREVIATIONS

- STM → STORM
- SAN → SANITARY
- WM → WATERMAIN
- WTR → WATER
- INV → INVERT
- MH → MANHOLE
- CB → CATCHBASIN
- TL → TOP OF LID
- OBV → OVERT
- FFE → FINISHED FLOOR ELEVATION
- BLDG → BUILDING
- SERV → SERVICE

1:250
0 2.5 5 10 15m

No.	Date	Description	By
4	FEB 03, 2023	ISSUED FOR ECA	A.C.
3	NOV 21, 2022	ISSUED FOR SITE PLAN APPLICATION	A.C.
2	AUG 31, 2022	ISSUED FOR SITE PLAN APPLICATION	A.C.
1	APR 18, 2022	ISSUED FOR SITE PLAN APPLICATION	A.C.

STAMPS

LICENSED PROFESSIONAL ENGINEER
 J. A. SAUVÉ
 100200100
 PROVINCE OF ONTARIO

LICENSED PROFESSIONAL ENGINEER
 A. CHAUMONT
 90409194
 PROVINCE OF ONTARIO

DESIGNED BY: APPROVED BY:

ENGINEER:

CIMA+

CLIENT:
 DREAM UNLIMITED
 30 ADELAIDE STREET EAST
 SUITE 301
 TORONTO, ON, M5C 3H1
 613-219-2722
 ZIBI (Project Address)
 310 Miwate Private
 OTTAWA, ONTARIO
 K1R 0E1

PROJECT NAME:
 ZIBI ONTARIO
 BLOCK 204
 315 PRIVE MIWATE PRIVATE,
 CHAUDIÈRE ISLAND
 OTTAWA, ONTARIO

SHEET TITLE:
 SEDIMENT & EROSION
 CONTROL PLAN

DISCIPLINE:
 CIVIL

DRAWER: S.C. POGGIOLI
DESIGNER: J. SAUVÉ
APPROVER: A. CHAUMONT
PROJECT No.: A000931
SHEET No.: 3 of 11

SCALE: 1:250
DATE: 2022/03/14
APPROVER: A. CHAUMONT
DRAWING No.: C003

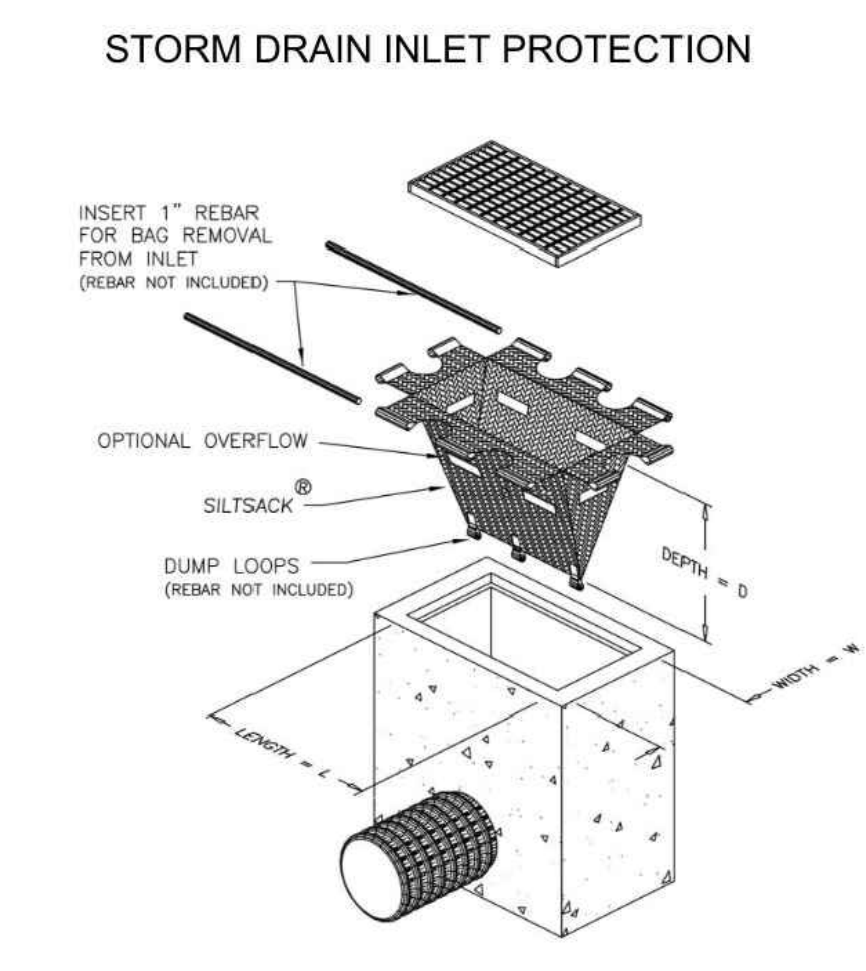
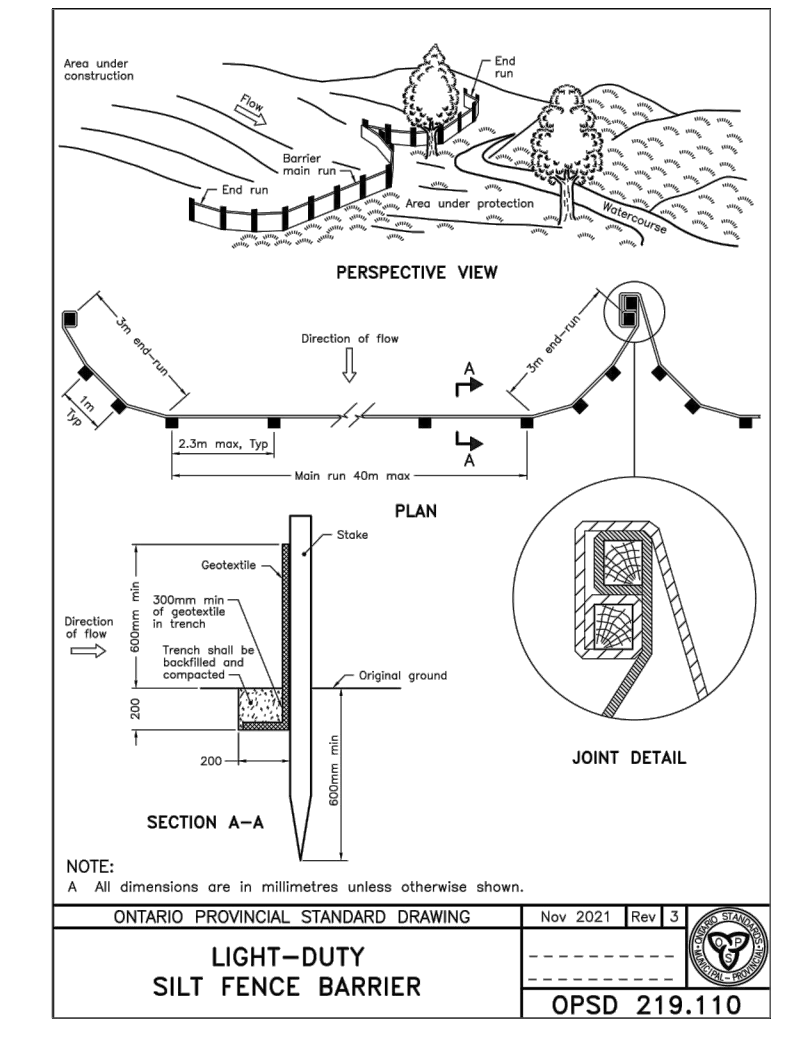

050 STORM DRAIN INLET PROTECTION
 SCALE: NTS

TITLEBLOCK 24238 VERT ENG 3.0
 PRINT DATE: 2023/03/14 PAPER SIZE: A0
 PATH: Z:\Cma-C\101\Projects\A000931_Zib\B\07_Ottawa400_Drafting\400_Civic-6_Servicing.dwg / LAYOUT: C005

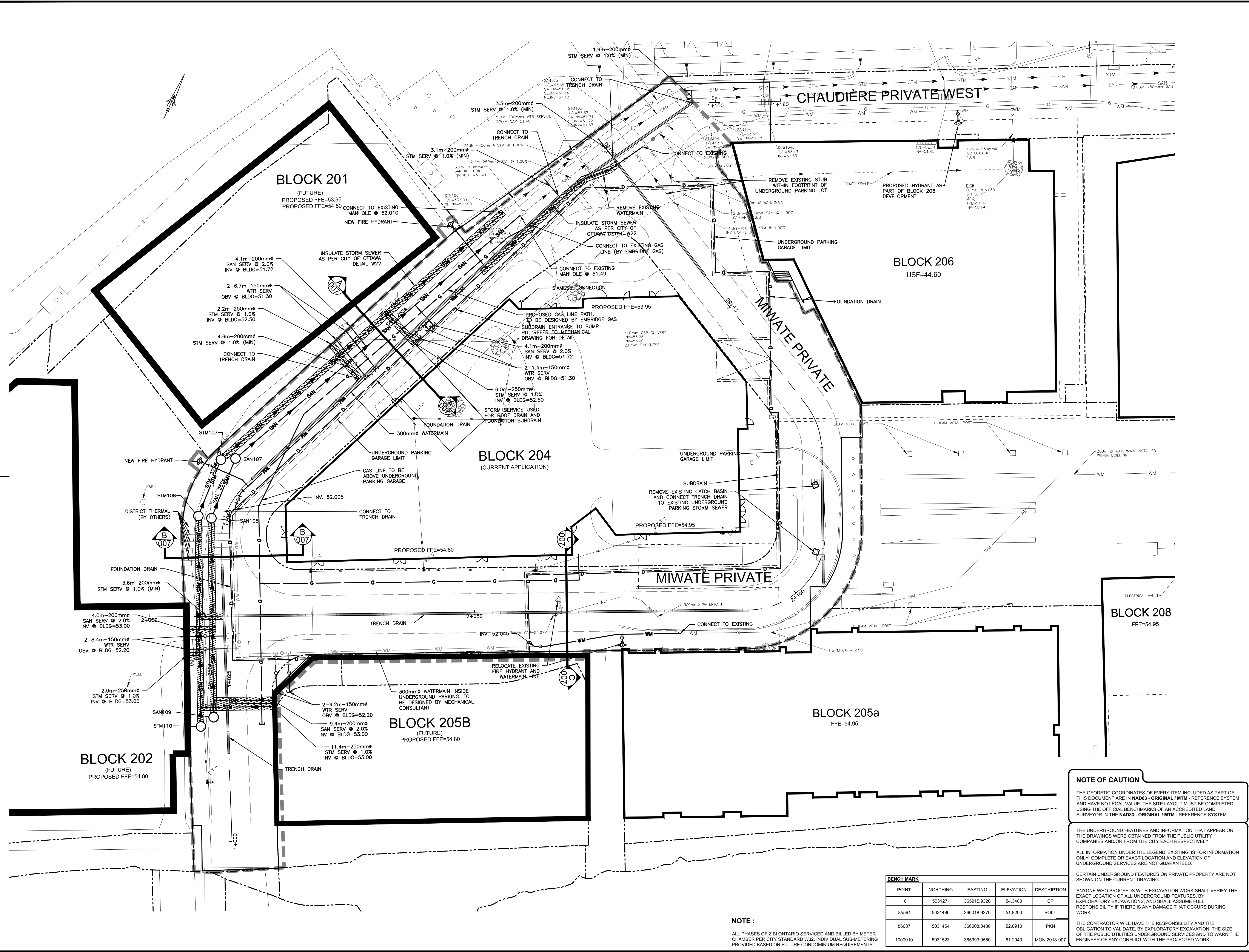

EXISTING

- WM WATERMAIN
- SAN SANITARY SEWER
- STM STORM SEWER
- D DRAIN
- G GAS LINE (APPROX. LOC.)
- T UNDERGROUND TELEPHONE (APPROX. LOC.)
- CA UNDERGROUND TRAFFIC CABLE (APPROX. LOC.)
- E UNDERGROUND ELECTRICITY (APPROX. LOC.)
- OT OVERHEAD WIRES

PROPOSED

- WM WATERMAIN
- SAN SANITARY SEWER
- STM STORM SEWER
- D DRAIN
- G GAS LINE (APPROX. LOC.)
- T UNDERGROUND TELEPHONE (APPROX. LOC.)
- CA UNDERGROUND TRAFFIC CABLE (APPROX. LOC.)
- E UNDERGROUND ELECTRICITY (APPROX. LOC.)
- OT OVERHEAD WIRES

Legend:

- LOT LINE
- RIGHT-OF-WAY LIMITS
- EASEMENT
- TOP OF SLOPE
- BOTTOM OF SLOPE
- CATCHBASIN
- MANHOLE/CATCHBASIN
- MANHOLE
- FIRE HYDRANT
- VALVE
- REDUCER
- TEE
- VALVE CHAMBER
- PRIVATE UTILITIES (WATERMAIN)
- NATURAL GAS VALVE
- TRENCH DRAIN
- STOP SIGN
- TRAFFIC LIGHT
- ELECTRICITY POLE
- TELEPHONE POLE
- ELECT-STREET LIGHT POLE
- ELECT-TEL-TURNFORMER POLE
- PRIVATE STREET LIGHT
- ELECTRICITY MANHOLE
- TELEPHONE MANHOLE
- SURVEY STATION
- WATERMAIN INSULATION
- UNDERGROUND PARKING GARAGE OUTLINE
- BOREHOLE (LOC. APPROX.)
- WORK LIMIT

ABBREVIATIONS

- STM - STORM
- SAN - SANITARY
- WM - WATERMAIN
- WTR - WATER
- INV - INVERT
- MH - MANHOLE
- CB - CATCHBASIN
- TL - TOP OF LID
- OBV - OVERTURN
- FFE - FINISHED FLOOR ELEVATION
- BLDG - BUILDING
- SERV - SERVICE

1:250

No.	Date	Description	By
4	FEB 03, 2023	ISSUED FOR ECA	A.C.
3	NOV 21, 2022	ISSUED FOR SITE PLAN APPLICATION	A.C.
2	AUG 31, 2022	ISSUED FOR SITE PLAN APPLICATION	A.C.
1	APR 18, 2022	ISSUED FOR SITE PLAN APPLICATION	A.C.

DESIGNED BY: **J.A. SAUVÉ** (Professional Engineer License 10020/100, 23-02-03)

APPROVED BY: **A. CHAUMONT** (Professional Engineer License 90409194, 23-02-03)

CIMA+

CLIENT: **DREAM UNLIMITED**
 30 ADELAIDE STREET EAST
 SUITE 301
 TORONTO, ON, M5C 3H1
 613-219-2722

ZIBI (Project Address)
 310 Miwate Private
 OTTAWA, ONTARIO
 K1R 0E1

PROJECT NAME: **ZIBI ONTARIO BLOCK 204**
 315 PRIVE MIWATE PRIVATE,
 CHAUDIERE ISLAND
 OTTAWA, ONTARIO

NOTE OF CAUTION

THE GEODETIC COORDINATES OF EVERY ITEM INCLUDED AS PART OF THIS DOCUMENT ARE IN NAD83 - ORIGINAL / MTM - REFERENCE SYSTEM AND HAVE NO LEGAL VALUE. THE SITE LAYOUT MUST BE COMPLETED USING THE OFFICIAL BENCHMARKS OF AN ACCREDITED LAND SURVEYOR IN THE NAD83 - ORIGINAL / MTM - REFERENCE SYSTEM.

THE UNDERGROUND FEATURES AND INFORMATION THAT APPEAR ON THE DRAWINGS WERE OBTAINED FROM THE PUBLIC UTILITY COMPANIES AND/OR FROM THE CITY EACH RESPECTIVELY.

ALL INFORMATION UNDER THE LEGEND 'EXISTING' IS FOR INFORMATION ONLY. COMPLETE OR EXACT LOCATION AND ELEVATION OF UNDERGROUND SERVICES ARE NOT GUARANTEED.

CERTAIN UNDERGROUND FEATURES ON PRIVATE PROPERTY ARE NOT SHOWN ON THE CURRENT DRAWING.

ANYONE WHO PROCEEDS WITH EXCAVATION WORK SHALL VERIFY THE EXACT LOCATION OF ALL UNDERGROUND FEATURES, BY EXPLORATORY EXCAVATIONS, AND SHALL ASSUME FULL RESPONSIBILITY IF THERE IS ANY DAMAGE THAT OCCURS DURING WORK.

THE CONTRACTOR WILL HAVE THE RESPONSIBILITY AND THE OBLIGATION TO VALIDATE, BY EXPLORATORY EXCAVATION, THE SIZE OF THE PUBLIC UTILITIES UNDERGROUND SERVICES AND TO WARN THE ENGINEER OF ANY CONFLICT WITH THE PROJECTED WORK.

BENCH MARK

POINT	NORTHING	EASTING	ELEVATION	DESCRIPTION
10	5031271	365915.9320	54.3480	CP
85591	5031480	366018.9270	51.8200	BOLT
88037	5031454	366008.0430	52.0910	PKN
1000010	5031523	365903.0550	51.2040	MON 2018-007

NOTE:

ALL PHASES OF ZIBI ONTARIO SERVICED AND BILLED BY METER CHAMBER PER CITY STANDARD W32. INDIVIDUAL SUB-METERING PROVIDED BASED ON FUTURE CONDOMINIUM REQUIREMENTS.

SHEET TITLE: **SITE SERVICING LAYOUT**

DISCIPLINE: **CIVIL**

DRAWER: **S.C. POGGIOLI** SCALE: 1:250

DESIGNER: **J. SAUVÉ** DATE: 2022/03/14

APPROVER: **A. CHAUMONT** APPROVER: **A. CHAUMONT**

PROJECT No.: **A000931** DRAWING No.: **C005**

SHEET No.: **7 of 11**

TITLE BLOCK 24068 VERT ENG 3.0
 PRINT DATE: 2023/03/14 PAPER SIZE: A0
 PATH: Z:\Cma-CO\0101_P\Project\A000931_Z01_Bloc 7 - Ottawa\A000_Drafting\480_Civic-3_Servicing.dwg / LAYOUT: C006A

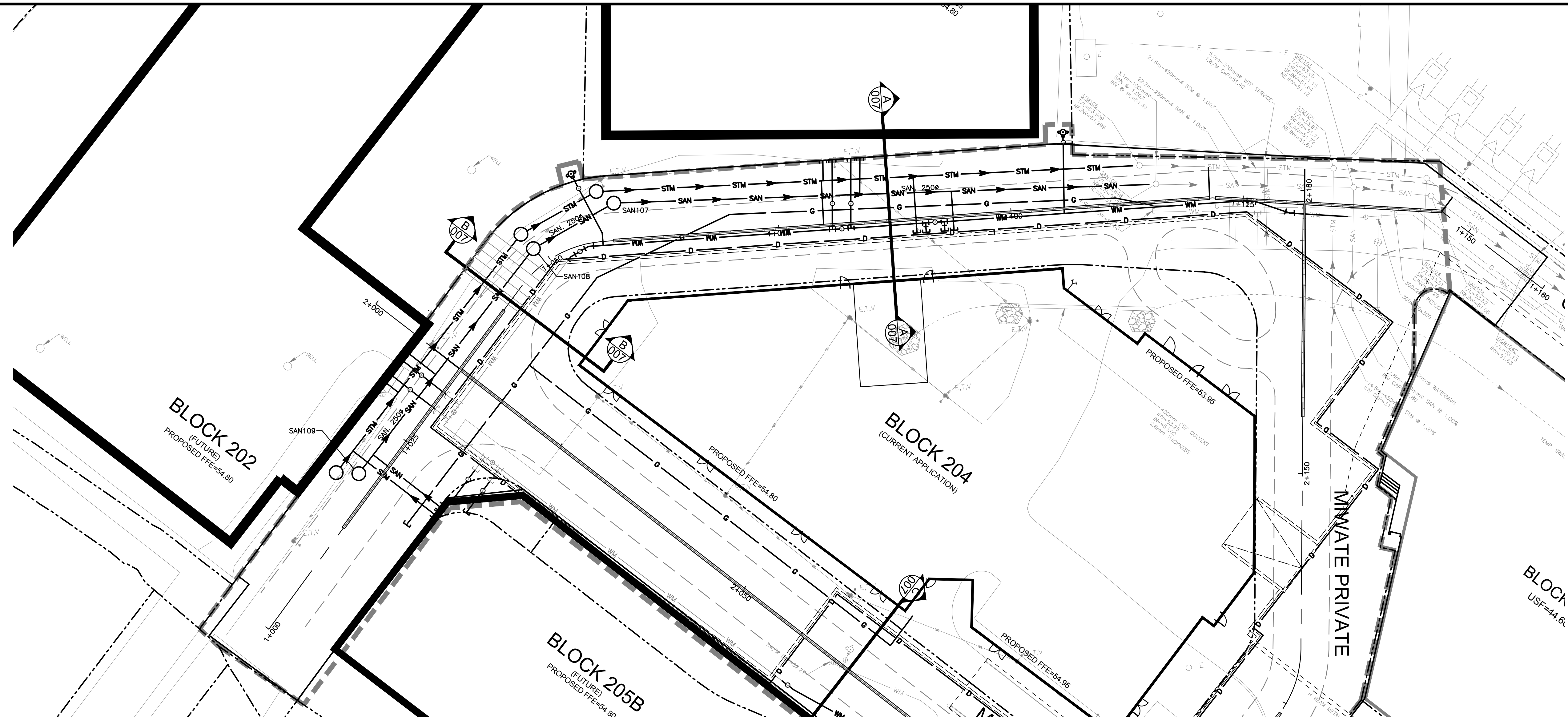

EXISTING	WATERMAIN	PROPOSED
WM	WATERMAIN	WM
SAN	SANITARY SEWER	SAN
STM	STORM SEWER	STM
D	DRAIN	D
G	GAS LINE (APPROX. LOC.)	G
T	UNDERGROUND TELEPHONE (APPROX. LOC.)	T
CA	UNDERGROUND CABLE (APPROX. LOC.)	CA
E	UNDERGROUND ELECTRICITY (APPROX. LOC.)	E
	OVERHEAD WIRES	
	LOT LINE	
	RIGHT-OF-WAY LIMITS	
	EASEMENT	
	TOP OF SLOPE	
	DITCH CENTER	
	BOTTOM OF SLOPE	
	CATCHBASIN	
	MANHOLE	
	FIRE HYDRANT	
	VALVE	
	REDUCER	
	TEE	
	VALVE CHAMBER	
	PRIVATE UTILITIES (WATERMAIN)	
	NATURAL GAS VALVE	
	TRENCH DRAIN	
	STOP SIGN	
	TRAFFIC LIGHT	
	ELECTRICITY POLE	
	ELECT. TEL. STREET LIGHT POLE	
	ELECT. TEL. TRANSFORMER POLE	
	PRIVATE STREET LIGHT	
	ELECTRICITY MANHOLE	
	TELEPHONE MANHOLE	
	SURVEY STATION	
	WATERMAIN INSULATION	
	UNDERGROUND PARKING	
	GARAGE OUTLINE	
	BORHOLE (LOC. APPROX.)	
	WORK LIMIT	

ABBREVIATIONS	
STM	→ STORM
SAN	→ SANITARY
WM	→ WATERMAIN
WTR	→ WATER
INV	→ INVERT
MH	→ MANHOLE
CB	→ CATCHBASIN
T/L	→ TOP OF LID
OBV	→ OBVERT
FFE	→ FINISHED FLOOR ELEVATION
BLDG	→ BUILDING
SERV	→ SERVICE

No.	Date	Description	By
4	FEB 03, 2023	ISSUED FOR ECA	A.C.
3	NOV 21, 2022	ISSUED FOR SITE PLAN APPLICATION	A.C.
2	AUG. 31, 2022	ISSUED FOR SITE PLAN APPLICATION	A.C.
1	APR. 18, 2022	ISSUED FOR SITE PLAN APPLICATION	A.C.

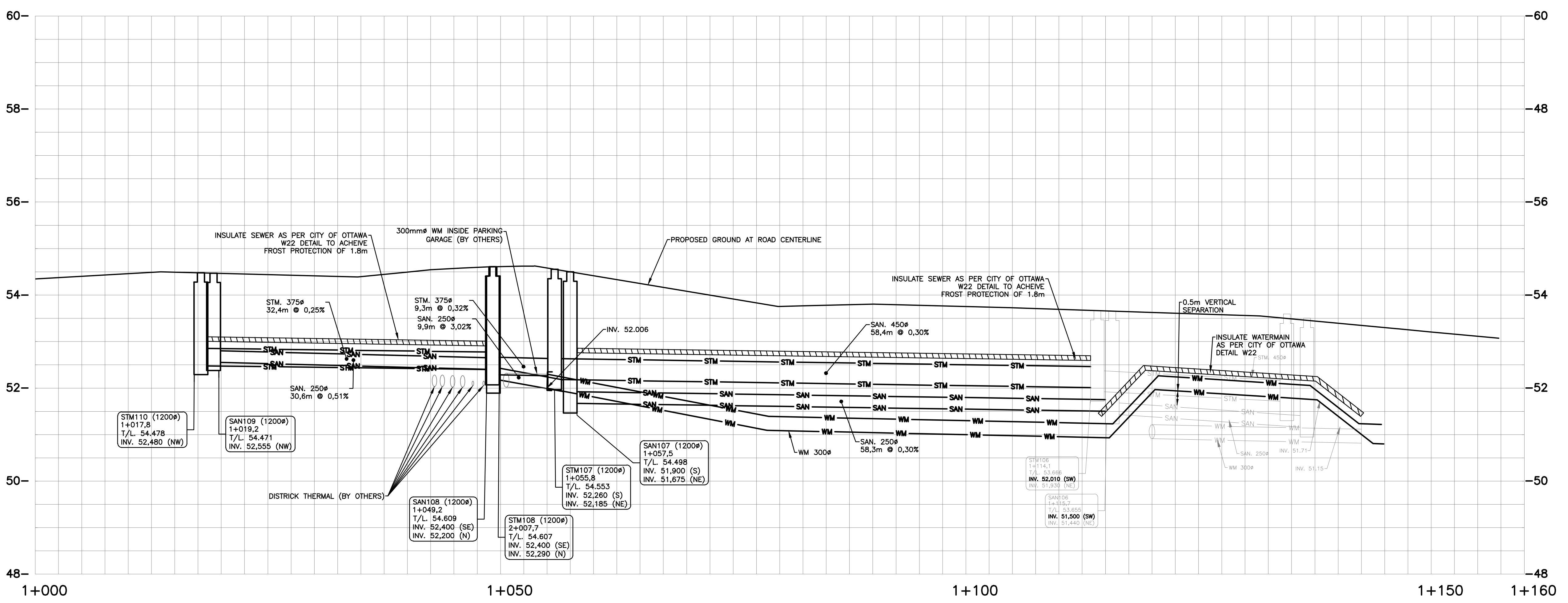

<p>DESIGNED BY: CIMA+</p>	
<p>CLIENT: DREAM UNLIMITED 30 ADELAIDE STREET EAST SUITE 301 TORONTO, ON, M5C 3H1 613-219-2722</p> <p>ZIBI (Project Address) 310 Mivate Private OTTAWA, ONTARIO K1R 0E1</p>	
<p>PROJECT NAME: ZIBI ONTARIO BLOCK 204 315 PRIVE MIWATE PRIVATE, CHAUDIERE ISLAND OTTAWA, ONTARIO</p>	
<p>SHEET TITLE: PLAN AND PROFILE STA. 1+000 TO 1+145</p>	
<p>DISCIPLINE: CIVIL</p>	
<p>DRAFTER: S.C. POGGIOLI</p>	<p>SCALE: H=1:250 V=1:50</p>
<p>DESIGNER: J. SAUVE</p>	<p>DATE: 2022/03/14</p>
<p>APPROVER: A. CHAUMONT</p>	<p>APPROVER: A. CHAUMONT</p>
<p>PROJECT No.: A000931</p>	<p>DRAWING No.: C006A</p>
<p>SHEET No.: 8 of 11</p>	<p>18749</p>

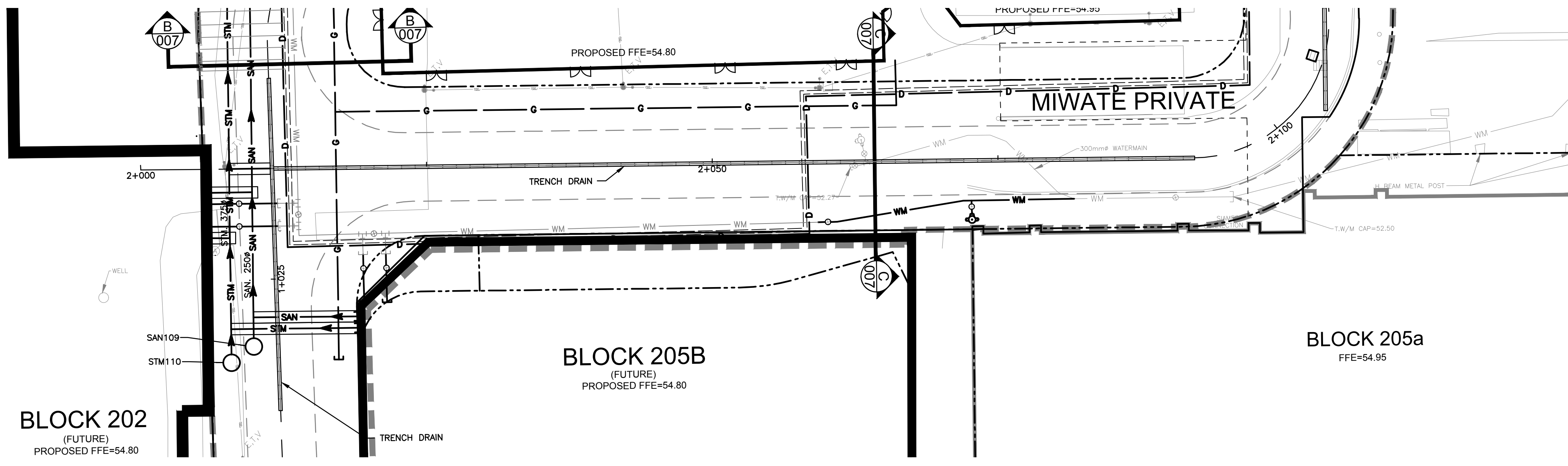

BLOCK 202
 (FUTURE)
 PROPOSED FFE=54.80

BLOCK 205B
 (FUTURE)
 PROPOSED FFE=54.80

BLOCK 205a
 FFE=54.95

EXISTING	PROPOSED
WM	WM
SAN	SAN
STM	STM
D	D
G	G
T	T
CA	CA
E	E
OVERHEAD WIRES	OVERHEAD WIRES
LOT LINE	LOT LINE
RIGHT-OF-WAY LIMITS	RIGHT-OF-WAY LIMITS
EASEMENT	EASEMENT
TOP OF SLOPE	TOP OF SLOPE
DITCH CENTER	DITCH CENTER
BOTTOM OF SLOPE	BOTTOM OF SLOPE
CATCHBASIN	CATCHBASIN
MANHOLE/CATCHBASIN	MANHOLE/CATCHBASIN
MANHOLE	MANHOLE
FIRE HYDRANT	FIRE HYDRANT
VALVE	VALVE
REDUCER	REDUCER
TEE	TEE
VALVE CHAMBER	VALVE CHAMBER
PRIVATE UTILITIES (WATERMAIN)	PRIVATE UTILITIES (WATERMAIN)
NATURAL GAS VALVE	NATURAL GAS VALVE
TRENCH DRAIN	TRENCH DRAIN
SIGN	SIGN
STOP SIGN	STOP SIGN
TRAFFIC LIGHT	TRAFFIC LIGHT
ELECTRICITY POLE	ELECTRICITY POLE
TELEPHONE POLE	TELEPHONE POLE
ELECT. TEL. STREET LIGHT POLE	ELECT. TEL. STREET LIGHT POLE
ELECT. TEL. TRANSFORMER POLE	ELECT. TEL. TRANSFORMER POLE
PRIVATE STREET LIGHT	PRIVATE STREET LIGHT
ELECTRICITY MANHOLE	ELECTRICITY MANHOLE
TELEPHONE MANHOLE	TELEPHONE MANHOLE
SURVEY STATION	SURVEY STATION
WATERMAIN INSULATION	WATERMAIN INSULATION
UNDERGROUND PARKING GARAGE OUTLINE	UNDERGROUND PARKING GARAGE OUTLINE
BORING (LOC. APPROX.)	BORING (LOC. APPROX.)
WORK LIMIT	WORK LIMIT

ABBREVIATIONS		
STM	→	STORM
SAN	→	SANITARY
WM	→	WATERMAIN
WTR	→	WATER
INV	→	INVERT
MH	→	MANHOLE
CB	→	CATCHBASIN
T/L	→	TOP OF LID
OBV	→	OBVERT
FFE	→	FINISHED FLOOR ELEVATION
BLDG	→	BUILDING
SERV	→	SERVICE

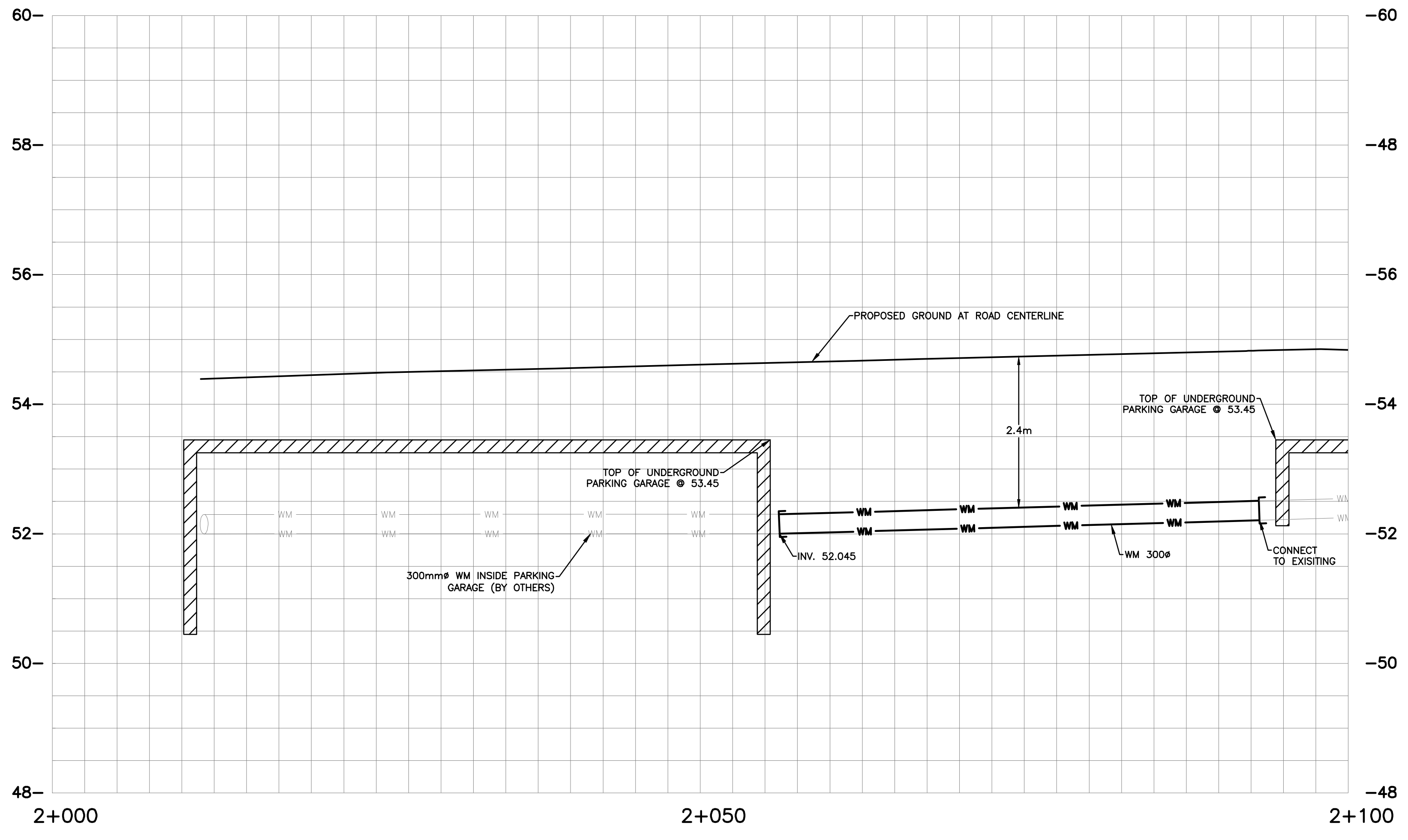

No.	Date	Description	By
4	FEB 03, 2023	ISSUED FOR ECA	A.C.
3	NOV 21, 2022	ISSUED FOR SITE PLAN APPLICATION	A.C.
2	AUG. 31, 2022	ISSUED FOR SITE PLAN APPLICATION	A.C.
1	APR. 18, 2022	ISSUED FOR SITE PLAN APPLICATION	A.C.

DESIGNED BY:

APPROVED BY:



CLIENT:
DREAM UNLIMITED
 30 ADELAIDE STREET EAST
 SUITE 301
 TORONTO, ON, M5C 3H1
 613-219-2722

ZIBI (Project Address)
 310 Miwate Private
 OTTAWA, ONTARIO
 K1R 0E1

PROJECT NAME:
**ZIBI ONTARIO
 BLOCK 204
 315 PRIVE MIWATE PRIVATE,
 CHAUDIERE ISLAND
 OTTAWA, ONTARIO**

SHEET TITLE:
**PLAN AND PROFILE
 STA. 2+000 TO 2+100**

DISCIPLINE: CIVIL	
DRAFTER: S.C. POGGIOLI	SCALE: H=1:250 V=1:50
DESIGNER: J. SAUVÉ	DATE: 2022/03/14
APPROVER: A. CHAUMONT	APPROVER: A. CHAUMONT
PROJECT No.: A000931	DRAWING No.: C006B
SHEET No.: 9 of 11	

TITILEBLOCK 24x36 VERT ENG 3.0

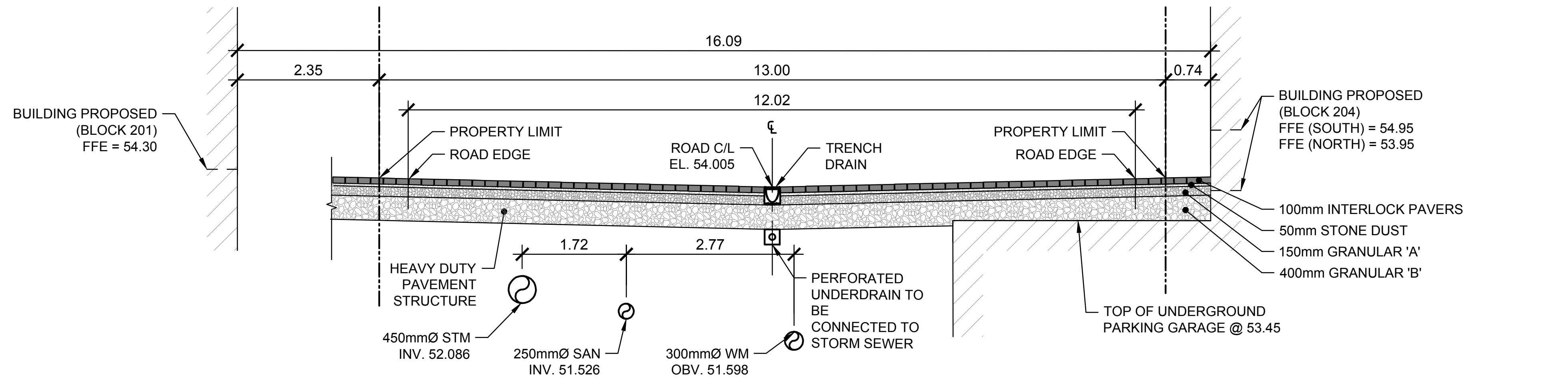

SECTION A-A
STA 1+091.31

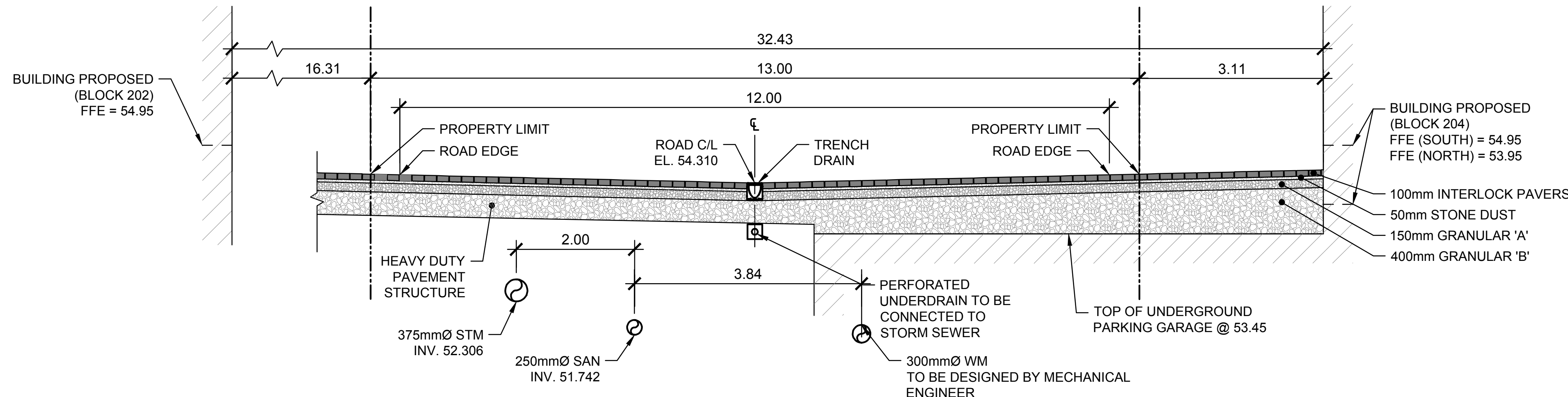

SECTION B-B
STA 1+048.15

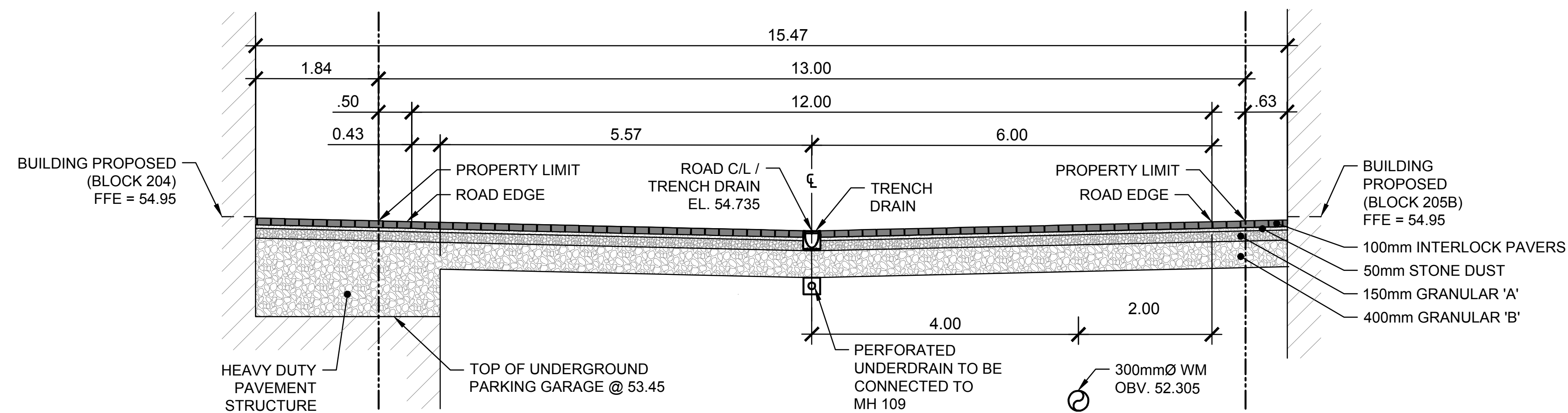

SECTION C-C
STA 2+056.38

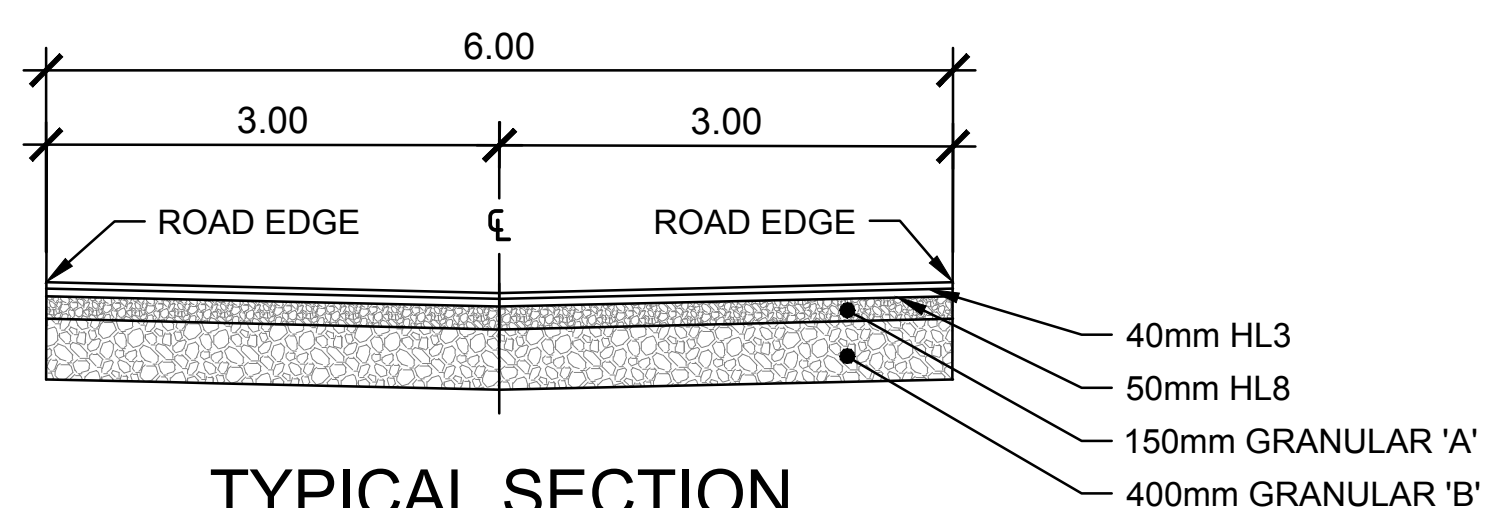

TYPICAL SECTION
INTERIM ASPHALT



APPROX. 16"W x 24"H



APPROX. 16"W x 6"H

100 UNDERGROUND PARKING STRUCTURE SIGN
SCALE: NTS

NOTE:
SIGNS TO BE MANUFACTURED OF METAL OR PLASTIC LAMICOID WITH APPROXIMATE DIMENSION SHOWN IN DETAIL. SIGNS TO BE INSTALLED ON EXTERIOR BUILDING WALL. SIGNS TO BE VISIBLE AND INSTALLED AT A HEIGHT OF 60'- 96" FROM THE GROUND.

No.	Date	Description	By
4	FEB 03, 2023	ISSUED FOR ECA	A.C.
3	NOV 21, 2022	ISSUED FOR SITE PLAN APPLICATION	A.C.
2	AUG. 31, 2022	ISSUED FOR SITE PLAN APPLICATION	A.C.
1	APR. 18, 2022	ISSUED FOR SITE PLAN APPLICATION	A.C.

DESIGNED BY: APPROVED BY:



CLIENT:
DREAM UNLIMITED
30 ADELAIDE STREET EAST
SUITE 301
TORONTO, ON, M5C 3H1
613-219-2722
ZIBI (Project Address)
310 Mivatte Private
OTTAWA, ONTARIO
K1R 0E1

PROJECT NAME:
ZIBI ONTARIO
BLOCK 204
315 PRIVE MIWATE PRIVATE,
CHAUDIERE ISLAND
OTTAWA, ONTARIO

SHEET TITLE:
TYPICAL CROSS SECTIONS
AND DETAILS

DISCIPLINE:
CIVIL

DRAFTER: S.C. POGGIOLI	SCALE: 1:50
DESIGNER: J. SAUVÉ	DATE: 2022/03/14
APPROVER: A. CHAUMONT	APPROVER: A. CHAUMONT
PROJECT No.: A000931	DRAWING No.: C007
SHEET No.: 10 of 11	

PRINT DATE: 2023/02/01 / PAPER SIZE: ---
PATH: Z:\Cms-CTD\Dr\Projects\A000931_Zib\Bldg 7_Ottawa\400_Drafting\400_Civic-3_Servicing.dwg / LAYOUT: C007

TITLE LOCK 24383 VERT ENG 3.0
 PRINT DATE: 2023/03/14 PAPER SIZE: A0
 PATH: Z:\Cma\CI\001\Projects\A000931_2b\01\Drawings\400_Civ\400_SWM.dwg / LAYOUT: C008_SWM

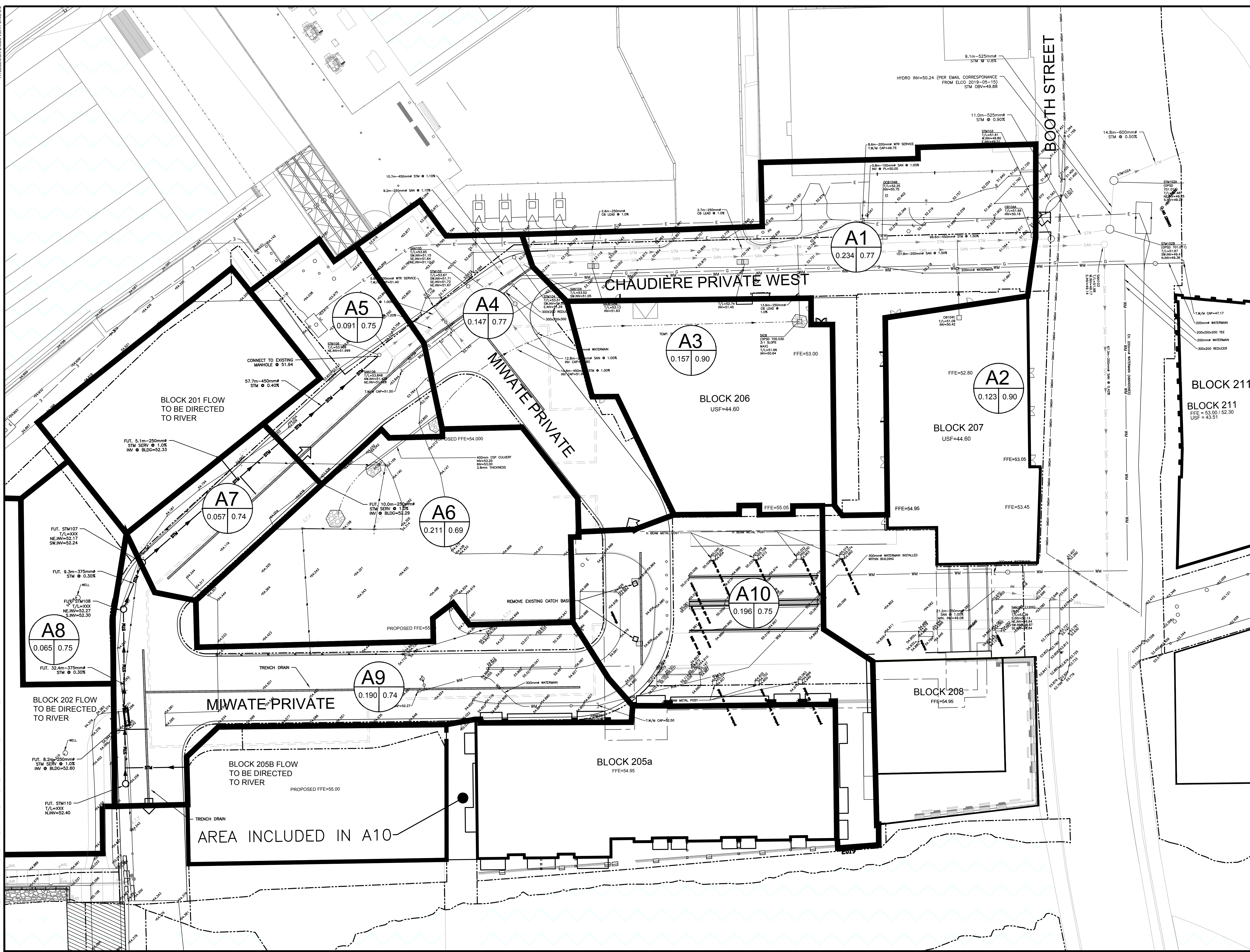

EXISTING		PROPOSED	
WM	WATERMAIN	WM	WATERMAIN
SS	SANITARY SEWER	SS	SANITARY SEWER
STM	STORM SEWER	STM	STORM SEWER
D	DRAIN	D	DRAIN
G	GAS LINE (APPROX. LOC.)	G	GAS LINE (APPROX. LOC.)
T	UNDERGROUND TELEPHONE (APPROX. LOC.)	T	UNDERGROUND TELEPHONE (APPROX. LOC.)
CA	UNDERGROUND TRAFFIC CABLE (APPROX. LOC.)	CA	UNDERGROUND TRAFFIC CABLE (APPROX. LOC.)
E	OVERHEAD WIRES	E	OVERHEAD WIRES
	FENCE		FENCE
	LOT LINE		LOT LINE
	RIGHT-OF-WAY LIMITS		RIGHT-OF-WAY LIMITS
	EASEMENT		EASEMENT
	TOP OF SLOPE		TOP OF SLOPE
	DITCH CENTER		DITCH CENTER
	BOTTOM OF SLOPE		BOTTOM OF SLOPE
	CATCHBASIN		CATCHBASIN
	MANHOLE/CATCHBASIN		MANHOLE/CATCHBASIN
	MANHOLE		MANHOLE
	FIRE HYDRANT		FIRE HYDRANT
	VALVE		VALVE
	REDUCER		REDUCER
	TEE		TEE
	VALVE CHAMBER		VALVE CHAMBER
	PRIVATE UTILITIES (WATERMAIN)		PRIVATE UTILITIES (WATERMAIN)
	ELEVATION		+ 99.000
	BOREHOLE (LOC. APPROX.)		BOREHOLE (LOC. APPROX.)
	OVERLAND FLOW		OVERLAND FLOW
	TRENCH DRAIN		TRENCH DRAIN
	WORK LIMIT		WORK LIMIT
	UNDERGROUND PARKING		UNDERGROUND PARKING
	GARAGE LIMIT		GARAGE LIMIT

Sub-catchment	A4	0.305	0.69
Area in Hectares			
Coefficient de ruissellement			
Overland flow			
Catchment area limit			

No.	Date	Description	By
4	FEB 03, 2023	ISSUED FOR ECA	A.C.
3	NOV 21, 2022	ISSUED FOR SITE PLAN APPLICATION	A.C.
2	AUG 31, 2022	ISSUED FOR SITE PLAN APPLICATION	A.C.
1	APR 18, 2022	ISSUED FOR SITE PLAN APPLICATION	A.C.

STAMPS:

DESIGNED BY: **CIMA+** (Professional Engineer Seal: J.A. SAUVÉ, 10020/100, 23-02-03)

APPROVED BY: **CIMA+** (Professional Engineer Seal: A. CHAUMONT, 90409194, 23-02-03)

CLIENT: DREAM UNLIMITED
 30 ADELAIDE STREET EAST
 SUITE 301
 TORONTO, ON, M5C 3H1
 613-219-2722

ZIBI (Project Address)
 310 Mivatte Private
 OTTAWA, ONTARIO
 K1R 0E1

PROJECT NAME: ZIBI ONTARIO BLOCK 204
 315 PRIVE MIWATTE PRIVATE,
 CHAUDIERE ISLAND
 OTTAWA, ONTARIO

SHEET TITLE: STORMWATER MANAGEMENT PLAN

DISCIPLINE: CIVIL

DRAWN BY: S.C. POGGIOLI
 DESIGNER: J. SAUVÉ
 APPROVER: A. CHAUMONT

SCALE: 1:300
 DATE: 2022/03/14
 APPROVER: A. CHAUMONT

PROJECT No.: A000931
 SHEET No.: 11 of 11

C008