

INDEX		
DWG	DESCRIPTION	REVISION
C000	COVER	00
C001	SITE SERVICING PLAN	02
C002	GRADING PLAN	02
C003	EROSION AND SEDIMENT CONTROL PLAN	02
C101	DETAILS (1 OF 4)	02
C102	DETAILS (2 OF 4)	02
C103	DETAILS (3 OF 4)	02
C104	DETAILS (4 OF 4)	02
C700	REMOVALS PLAN	02
C701	ROOF DRAIN LAYOUT & PONDING	02
C800	EXISTING DRAINAGE AREA PLAN	02
C801	PROPOSED DRAINAGE AREA PLAN	02

# OCH FRIEL STREET / CHAPEL 200/201 FRIEL STREET

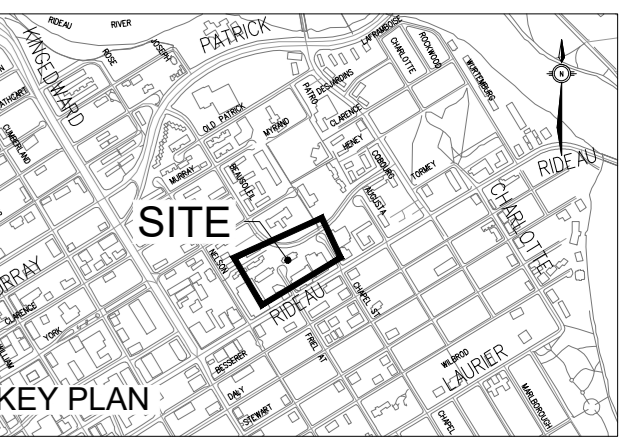

ISSUED

No.	Date	Description
0	2023 MAR 22	ISSUED FOR SITE PLAN APPROVAL
1	2023 MAY 12	ISSUED FOR 100% SCHEMATIC DESIGN
2	2023 MAY 18	ISSUED FOR ZONING AND SITE PLAN CONTROL - RESUBMISSION #1

**LEGEND**

- NEW AREA DRAIN (REFER TO MECHANICAL FOR CONTINUATION)
- NEW CATCH BASIN
- NEW STORM SEWER
- NEW SANITARY SEWER
- NEW WATERMAIN
- NEW WATER VALVE AND VALVE BOX (W24)
- EXISTING STORM/SANITARY MANHOLE
- EXISTING STORM SEWER
- EXISTING SANITARY SEWER BY
- EXISTING WATERMAIN
- ▼ NEW ENTRANCE
- STORMWATER MANAGEMENT CISTERN
- SITE BOUNDARY
- EDGE OF SUBSTRUCTURE
- ENTRANCE OF PARKING GARAGE ACCESS RAMP
- PROPERTY LINE

**CATCH BASIN DATA**

NO.	COVER	STRUCT.	ELEVATION		NOTES	CB CONNECTION		
			T/FRAME	LOW/INV		DIA (mm)	TYPE	LENGTH (m)
CB1	S22	705.010B	61.00	59.72		250	PVC DR35	N/A
CB2	S22	705.010B	58.78	57.50		250	PVC DR35	5.5
CBM1	S28.1	701.011	61.20	59.92		250	PVC DR35	7.5

**NEW STORM STRUCTURE**

NO.	COVER	STRUCT.	ELEVATION		LOCATION		NOTES
			T/FRAME	INVERTS	NORTHING	EASTING	
STMH1	S24.1 OR OPSD 401.010 TYPE B	701.011	61.45	59.02 (N) 58.98(SW)	5032694.90	368763.08	

**PIPE CROSSING TABLE**

NO.	PIPE	CLEARANCE OVER	EXISTING INVERT	STM OBV	STM INV
1	200mmØ WM 0.97m	CLEARANCE OVER 250mmØ SAN	WM INV=59.90, STM OBV=58.93		
2	200mmØ WM 0.30m	CLEARANCE OVER 250mmØ STM	WM INV=59.50, STM OBV=59.20		
3	250mmØ STM 0.48m	CLEARANCE OVER 600mmØ SAN	STM INV=58.78, SAN OBV=58.30		
4	200mmØ WM 0.41m	CLEARANCE OVER 200mmØ STM	WM INV=59.48, STM OBV=59.07		
5	200mmØ STM 0.60m	CLEARANCE OVER 600mmØ SAN	STM INV=58.88, SAN OBV=58.28		

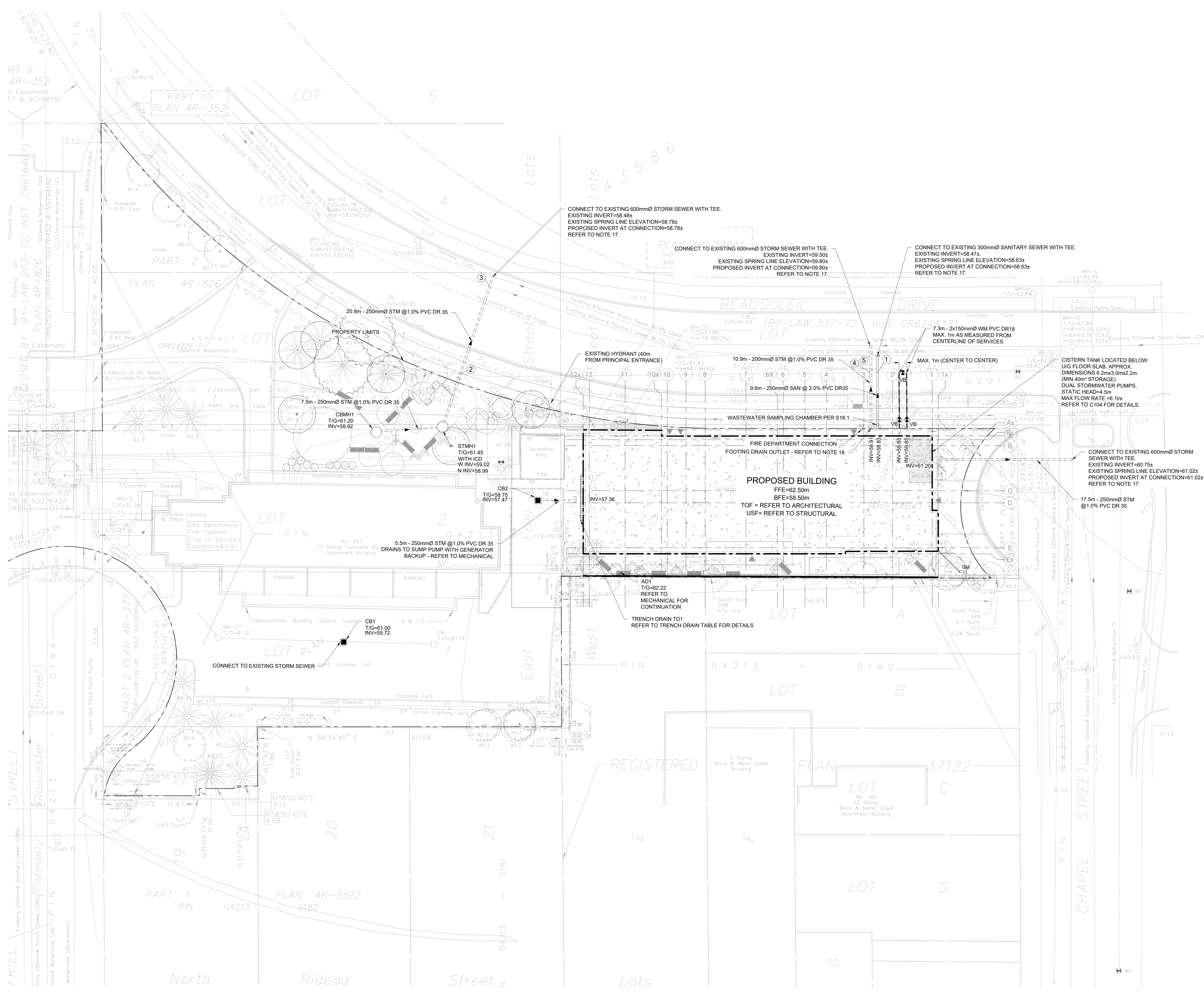

- NOTES:**
- GENERAL**
- TOPOGRAPHICAL SURVEY PREPARED BY FARLEY, SMITH & DENIS SURVEYING LTD. DATED SEPT 13, 2022. NAD 83 DATUM COVD-1928-1978.
  - SITE BENCHMARK: HYDRANT TOP OF SPINDLE ELEV. 61.91
  - SERVICES ARE TO BE CONSTRUCTED TO 1.0m FROM FACE OF BUILDING.
  - REFER TO "SITE SERVICING AND STORMWATER MANAGEMENT DESIGN BRIEF" PREPARED BY MORRISON HERSHFIELD.
  - REFER TO GEOTECHNICAL INVESTIGATION REPORT (AUG 2017) GEOTECH REPORT FOR 20-11 PREPARED BY PATTERSON GROUP FOR SUBSURFACE CONDITIONS. CONSTRUCTION RECOMMENDATIONS AND GEOTECHNICAL INSPECTION REQUIREMENTS. THE GEOTECHNICAL CONSULTANT SHALL REVIEW EXCAVATIONS PRIOR TO THE PLACEMENT OF GRANULAR MATERIAL.
  - CONTRACTOR TO VERIFY ALL EXISTING UTILITY ELEVATIONS AT CONNECTION AND CROSSING LOCATIONS PRIOR TO CONSTRUCTION AND ADVISE THE ENGINEER OF ANY DISCREPANCIES.
  - UNLESS DIRECTED OTHERWISE ANY DAMAGED ASPHALT OR CURB (REGARDLESS OF WHETHER WITHIN OR EXTERNAL TO THE SITE) SHALL BE REINSTATED IN ACCORDANCE WITH CITY STD. DET. R1 AND S1.
  - UNLESS DIRECTED OTHERWISE THE CONTRACTOR SHALL REINSTATE ALL SIGNS, LIGHTING AND OTHER STREET FURNITURE DISTURBED BY THE WORK.
  - THE CONTRACTOR SHALL DEVELOP AND IMPLEMENT TRAFFIC MANAGEMENT PLANS FOR WORK IN RIGHT OF WAY IN ACCORDANCE WITH OTM BOOK 7.
  - THE CONTRACTOR SHALL PROVIDE ANY TEMPORARY SERVICING NEEDED, AND SHALL ALSO COORDINATE WITH OTHER TRADES AS NECESSARY.

- SEWERS**
- ALL STORM SEWERS, SANITARY SEWERS AND CATCH BASINS LEADS SHALL BE PVC DR 35 UNLESS OTHERWISE SPECIFIED.
  - REFER TO CITY STD. DETAIL S6 ON DRAWING C102 FOR SEWER INSTALLATION.
  - CONTRACTOR SHALL MAINTAIN EXISTING SEWER FLOWS DURING CONSTRUCTION IN ACCORDANCE WITH CITY OF OTTAWA SPECIFICATIONS.
  - ALL MAINTENANCE HOLES, CATCHBASINS AND AREA DRAINS SHALL BE ADJUSTED TO POST-CONSTRUCTION GRADE.
  - LEAKAGE TEST (SANITARY SEWER ONLY) AND CCTV INSPECTION SHALL BE COMPLETED AS PER CITY OF OTTAWA STANDARD R10. CONNECTION TO INSTALLATION OF BASE COURSE ASPHALT.
  - BACKWATER VALVES TO BE INSTALLED AS PER CITY OF OTTAWA STANDARD S14 & S14.2.
  - CONTRACTOR TO CONFIRM EXACT ELEVATION OF SEWER PRIOR TO CONSTRUCTION AND NOTIFY ENGINEER OF ANY DISCREPANCIES. ROAD CUT REINSTATEMENT AS PER CITY OF OTTAWA STANDARD R10. CONNECTION TO SEWERMAN PER S11.1
  - FOOTING DRAINS OUTLET TO THE BUILDINGS SUMP PUMP. THE BUILDING SUMP PUMP IS CONNECTED TO THE BACKUP GENERATOR.
- WATERMANS**
- REFER TO CITY STD. DETAIL W17 ON DRAWING C102 FOR WATERMAIN INSTALLATION.

- ALL WATERMAIN MATERIALS AND CONSTRUCTION METHODS SHALL BE IN ACCORDANCE WITH THE LATEST EDITION OF THE CITY OF OTTAWA STANDARD SPECIFICATIONS AND STANDARD DRAWINGS. PVC PIPE TO BE CLASS 150 DR18 TO LATEST EDITION OF A.W.W.A. SPECIFICATION C900 AND CSA 9137.3 LATEST AMENDMENT WITH GASKETED BELL AND SPIGOT COUPLINGS.
- THE CONTRACTOR SHALL BE RESPONSIBLE FOR OBTAINING A WATER PERMIT AS REQUIRED FROM THE CITY OF OTTAWA AND COMPLYING WITH ALL CITY OF OTTAWA REQUIREMENTS. THE CITY MAY REQUIRE THAT CERTAIN ACTIVITIES (E.G. VALVE OPERATION, CONNECTION OF NEW WATER SERVICE TO EXISTING WATERMAIN, DISINFECTION) BE CARRIED OUT ONLY BY CITY FORCES.
- ALL VALVES 300mm DIAMETER AND SMALLER SHALL INCLUDE A VALVE BOX AS PER W24.
- THE NEW WATERMAIN IS TO BE INSTALLED WITH A MINIMUM OF 2.4m COVER. WHERE 2.4m COVER IS NOT POSSIBLE, PROVIDE INSULATION IN ACCORDANCE WITH CITY OF OTTAWA STANDARD DETAILS W22 & W23.
- THRUST RESTRAINT SHALL BE PROVIDED BY BOTH RESTRAINING/RETAINING RINGS AND THRUST BLOCKS AT ALL DEAD END CAPS, PLUGS, VALVES, BENDS AND REDUCERS AS PER CITY OF OTTAWA STANDARD DETAILS W25.3, W25.4, W25.5 AND W25.6. ALL TEMPORARY THRUST RESTRAINTS ARE THE RESPONSIBILITY OF THE CONTRACTOR.
- TRACER WIRE SHALL BE PROVIDED FOR ALL NEW PVC WATERMANS IN ACCORDANCE WITH THE SPECIFICATIONS AND CITY OF OTTAWA STANDARD DETAIL W36.
- CATHODIC PROTECTION SHALL BE PROVIDED FOR ALL NEW WATERMANS IN ACCORDANCE WITH THE SPECIFICATIONS AND CITY OF OTTAWA STANDARD DETAILS W39, W40, W41, W42 AND W47. CATHODIC PROTECTION OF EXISTING WATERMANS SHALL ALSO BE PROVIDED AT CONNECTIONS BETWEEN EXISTING AND NEW WATERMANS.

- ADJUST ALL VALVE CHAMBERS, VALVE BOXES AND HYDRANTS TO FINISHED GRADE.
- UTILITY NOTE**
- THE POSITION OF POLE LINES, CONDUITS, WATERMANS, SEWERS AND OTHER UNDERGROUND AND OVERGROUND UTILITIES AND STRUCTURES IS NOT NECESSARILY SHOWN ON THE CONTRACT DRAWING AND, WHERE SHOWN, THE ACCURACY OF THE POSITION OF SUCH UTILITIES AND STRUCTURES IS NOT GUARANTEED. BEFORE STARTING WORK THE CONTRACTOR SHALL INFORM HIMSELF OF THE EXACT LOCATION OF ALL SUCH UTILITIES AND STRUCTURES, AND SHALL ASSUME ALL LIABILITY FOR DAMAGE TO THEM. THE CONTRACTOR WILL BE RESPONSIBLE FOR SUPPORTING AND PROTECTING ANY EXISTING UTILITIES, AS REQUIRED, IN ACCORDANCE WITH THE UTILITY OWNERS' REQUIREMENTS. CONTRACTOR IS REQUIRED TO OBTAIN LOCATES, IN ADVANCE OF EXCAVATION WORK, AND FORWARD COPIES OF THE LOCATES TO THE CONSULTANT AND THE OWNER PRIOR TO EXCAVATION.
  - ALL CROSSING OF EX. UTILITIES TO BE IN ACCORDANCE WITH CITY STD. DET. S10

**TRENCH DRAIN DATA**

NO.	TRENCH DRAIN WIDTH	GRATE	ELEVATION		TD CONNECTION			
			T/FRAME	LOW/INV	DIA (mm)	TYPE	LENGTH (m)	INV.
TD1	100mm	STAINLESS STEEL, ACCESSIBLE, HEEL SAFE, LIGHT DUTY (ACO 44714460 OR APPROVED EQUIVALENT)	58.50	57.70	200	PVC DR35	1.2	REFER TO MECHANICAL

NOTE: POLYMER CONCRETE TRENCH DRAIN WITH 2% INTERNAL SLOPE AND MATCHING CATCH BASIN, UNLESS OTHERWISE SPECIFIED.

**INLET CONTROL DEVICE DATA TABLE - STMH1**

DESIGN EVENT	ICD TYPE	DIAMETER OF OUTLET PIPE (mm)	DESIGN FLOW (L/s)	WATER ELEVATION (m)	REQUIRED VOLUME (m³)	TOTAL VOLUME PROVIDED (m³)
1.5 YR	HYDROVEX 50/VH-2	250mmØ PVC	2.1	60.17	4.9	42
1:100 YR	HYDROVEX 50/VH-2	250mmØ PVC	3.0	61.32	9.1	42

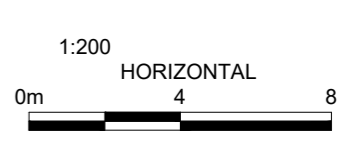

CONTRACTOR MUST CHECK & VERIFY ALL DIMENSIONS ON THE JOB. 50/40 SCALE DRAWING.

ALL DRAWINGS, SPECIFICATIONS AND RELATED DOCUMENTS ARE THE COPYRIGHT PROPERTY OF THE ARCHITECT AND MUST BE RETURNED UPON REQUEST. REPRODUCTION OF DRAWINGS, SPECIFICATIONS AND RELATED DOCUMENTS IN PART OR IN WHOLE IS FORBIDDEN WITHOUT THE WRITTEN PERMISSION OF THE ARCHITECT.

THIS DRAWING IS NOT TO BE USED FOR CONSTRUCTION LABELS, SIGNED BY THE ARCHITECT.

**OCH FRIEL STREET / CHAPEL**  
200/011 FRIEL STREET  
221021

**SITE SERVICING PLAN**

Scale: 1:200  
Project No: 22028200  
Date: 18/05/23

**C001**  
#18930

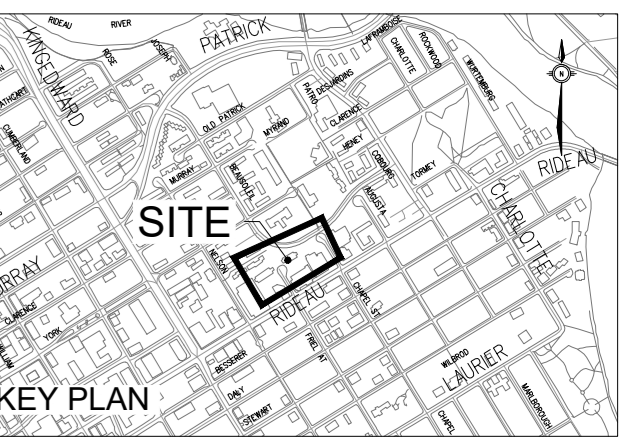

ISSUED

No.	Date	Description
0	2023 MAR 22	ISSUED FOR SITE PLAN APPROVAL
1	2023 MAY 12	ISSUED FOR 100% SCHEMATIC DESIGN
2	2023 MAY 18	ISSUED FOR REZONING AND SITE PLAN CONTROL - RESUBMISSION #1

- LEGEND**
- NEW AREA DRAIN
  - ⊙ PROPOSED MANHOLE
  - × (65.55) PROPOSED ELEVATION
  - × (65.75/7) PROPOSED TOP OF CURB ELEVATION
  - × (66.75/7) PROPOSED TOP OF WALL ELEVATION
  - PROPOSED SLOPE DIRECTION
  - ← MAJOR OVERLAND FLOW PATH
  - ▨ PAVERS - REFER TO LANDSCAPE
  - ▨ LIGHT/HEAVY DUTY ASPHALT PAVING
  - ▨ LIGHT DUTY CONCRETE
  - ▨ HEAVY DUTY CONCRETE
  - ▨ 40mm MILLING & REINSTATEMENT WITH HL3 OR SP12.5 ASPHALTIC CONCRETE
  - EXISTING ELEVATION
  - ⊙ EXISTING MANHOLE
  - CONCRETE CURB AS PER SC 1.1
  - PONDING ELEVATION (MAX 120mm)
  - ▼ NEW ENTRANCE
  - ▼ ENTRANCE OF PARKING GARAGE ACCESS RAMP
  - - - PROPERTY LINE

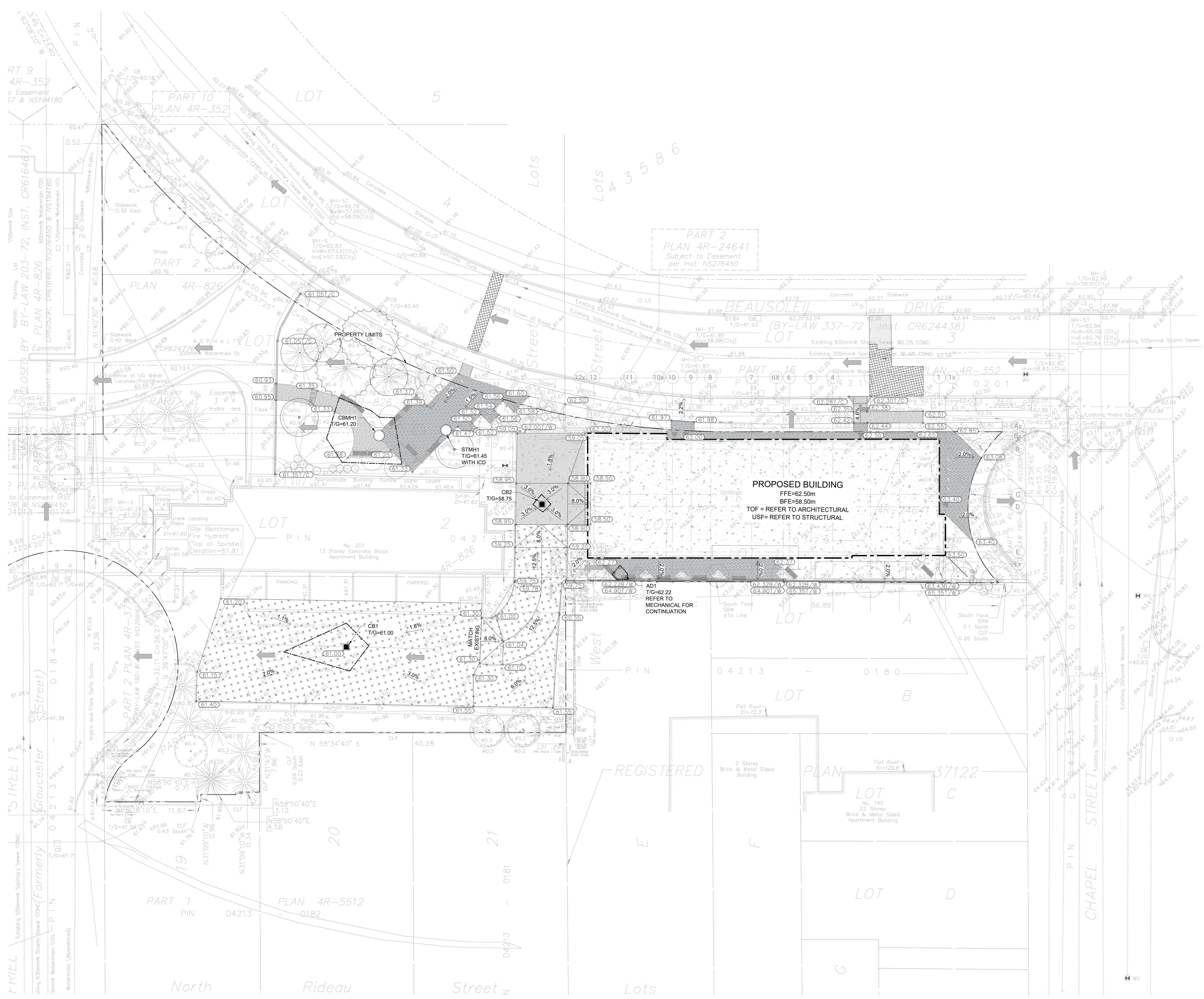

- NOTES**
1. ALL ELEVATIONS ARE GEODETIC AND IN METERS UNLESS OTHERWISE NOTED.
  2. THIS DRAWING SHALL BE READ IN CONJUNCTION WITH ALL OTHER DRAWINGS.
  3. REFER TO ARCHITECTURAL AND LANDSCAPE DRAWINGS FOR LAYOUT DIMENSIONS AND SURFACE FINISHES.
  4. ALL ELEVATIONS BY CURBS ARE EDGE OF PAVEMENT UNLESS OTHERWISE INDICATED.
  5. REINSTATE ALL DISTURBED/DAMAGED AREAS TO THEIR ORIGINAL CONDITION OR BETTER.
  6. PROVIDE POSITIVE DRAINAGE, MATCHING EXISTING OVERALL DRAINAGE PATTERN INDICATED.
  7. ALL WORK AND MATERIALS SHALL BE IN ACCORDANCE WITH CITY OF OTTAWA AND/OR ONTARIO PROVINCIAL STANDARDS.
  8. ALL TOPSOIL, ORGANIC OR DELETERIOUS MATERIAL MUST BE ENTIRELY REMOVED FROM BENEATH THE PROPOSED PAVED AREAS AS DIRECTED BY THE OWNER'S REPRESENTATIVE.
  9. SUBGRADE FOR THE PAVED AREAS SHALL BE PROOF ROLLED WITH A LARGE (10 TONNE MINIMUM) STEEL DRUM ROLLER UNDER DRY CONDITIONS. ANY SOFT AREAS EXPOSED FROM THE PROOF ROLLING SHOULD BE SUBCAVATED TO A DEPTH OF 500mm AND REPLACED WITH COMPACTED SUBGRADE FILL.
  10. ALL AREAS SHALL DRAIN AT A MINIMUM OF 1%. ANY DISCREPANCIES PREVENTING THIS SHALL BE REPORTED TO THE ENGINEER PRIOR TO CONTINUING WORK.
  11. BLEND NEW EARTHWORK INTO EXISTING, PROVIDING VERTICAL CURVES OR ROUNDING AT ALL TOP AND BOTTOM OF SLOPES.
  12. CONCRETE SIDEWALKS SHALL BE IN ACCORDANCE WITH CITY OF OTTAWA STANDARD DRAWING SC1.4 AND SC4 UNLESS SHOWN OTHERWISE.
  13. CONCRETE BARRIER CURBS SHALL BE IN ACCORDANCE WITH CITY OF OTTAWA STANDARD DRAWING SC1.1 UNLESS SHOWN OTHERWISE.
  14. SAW CUT AND KEY GRIND ASPHALT AT ALL TIE-INS PER CITY OF OTTAWA STANDARD R10.
  15. REINSTATE ANY LINE PAINTING DISTURBED BY THE WORK.
  16. REFER TO GEOTECHNICAL INVESTIGATION REPORT (AUG 2017 GEOTECH REPORT PG4129-1) PREPARED BY PATTERSON GROUP FOR SUBSURFACE CONDITIONS, CONSTRUCTION RECOMMENDATIONS AND GEOTECHNICAL INSPECTION REQUIREMENTS. THE GEOTECHNICAL CONSULTANT SHALL REVIEW EXCAVATIONS PRIOR TO THE PLACEMENT OF GRANULAR MATERIAL.

6. THE POSITION OF POLE LINES, CONDUITS, WATERMANS, SEWERS AND OTHER UNDERGROUND UTILITIES AND OVERGROUND UTILITIES AND STRUCTURES IS NOT NECESSARILY SHOWN ON THE CONTRACT DRAWING AND, WHERE SHOWN, THE ACCURACY OF THE POSITION OF SUCH UTILITIES AND STRUCTURES IS NOT GUARANTEED. BEFORE STARTING WORK THE CONTRACTOR SHALL INFORM HIMSELF OF THE EXACT LOCATION OF ALL SUCH UTILITIES AND STRUCTURES, AND SHALL ASSUME ALL LIABILITY FOR DAMAGE TO THEM. THE CONTRACTOR WILL BE RESPONSIBLE FOR SUPPORTING AND PROTECTING ANY EXISTING UTILITIES, AS REQUIRED, IN ACCORDANCE WITH THE UTILITY OWNERS' REQUIREMENTS. CONTRACTOR IS REQUIRED TO OBTAIN LOCATES, IN ADVANCE OF EXCAVATION WORK, AND FORWARD COPIES OF THE LOCATES TO THE CONSULTANT AND THE OWNER PRIOR TO EXCAVATION. HAND EXCAVATION IS REQUIRED PER UTILITY OWNERS' REQUIREMENTS.
7. CONTRACTOR IS RESPONSIBLE TO KEEP THE ROADS FREE AND CLEAN FROM THE MUD OR DEBRIS.
8. SWALES MUST HAVE MINIMUM 1.5% LONGITUDINAL AND SIDE SLOPE AND MAX 3H:1V SIDE SLOPE (S29).
9. **BENCHMARK NOTE:**  
TOPOGRAPHICAL SURVEY PREPARED BY FARLEY, SMITH & DENIS SURVEYING LTD. DATED SEPT 13, 2022, MTM ZONE 9, GEODETIC DATUM CGVD-1928-1978  
SITE BENCHMARK: HYDRANT TOP OF SPINDLE ELEV. 61.91

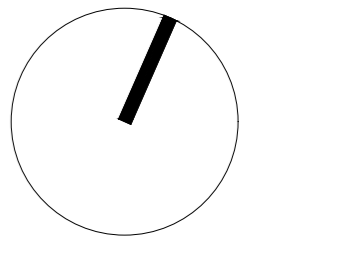
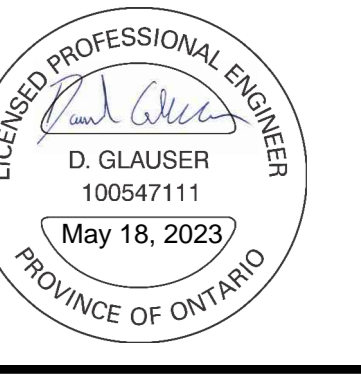

CONTRACTOR MUST CHECK AND VERIFY ALL DIMENSIONS ON THE JOB.  
NO 40% SCALE DRAWING.  
ALL DRAWINGS, SPECIFICATIONS AND RELATED DOCUMENTS ARE THE COPYRIGHT PROPERTY OF THE ARCHITECT AND MUST BE RETURNED UPON REQUEST. REPRODUCTION OF DRAWINGS, SPECIFICATIONS AND RELATED DOCUMENTS IN PART OR IN WHOLE IS FORBIDDEN WITHOUT THE WRITTEN PERMISSION OF THE ARCHITECT.  
THIS DRAWING IS NOT TO BE USED FOR CONSTRUCTION PURPOSES, UNLESS BY THE ARCHITECT.

**OCH FRIEL STREET / CHAPEL**  
200201 FRIEL STREET  
221021

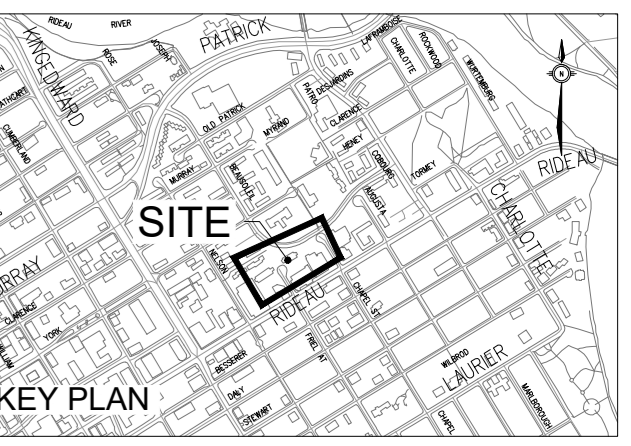

ISSUED

No.	Date	Description
0	2023 MAR 22	ISSUED FOR SITE PLAN APPROVAL
1	2023 MAY 12	ISSUED FOR 100% SCHEMATIC DESIGN
2	2023 MAY 18	ISSUED FOR REZONING AND SITE PLAN CONTROL - RESUBMISSION #1

**LEGEND**

- LIGHT DUTY SILT FENCE BARRIER (PER OPSD 219.110)
- CATCH BASIN PROTECTION (SILT SACK WITHIN CB, OR SURROUND CB WITH SILT SOCK)
- SEDIMENT CAPTURE FILTER SOCK HELD IN PLACE USING SANDBAGS

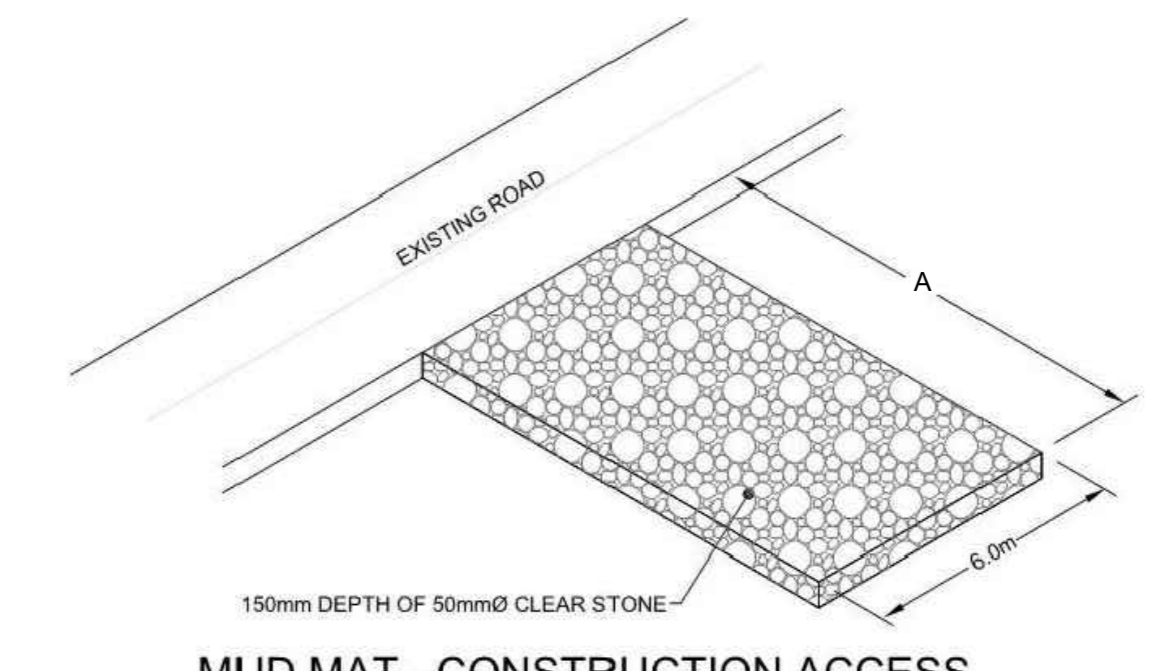

**MUD MAT - CONSTRUCTION ACCESS**  
N.T.S.

A - TO BE DETERMINED ON SITE IN CONJUNCTION WITH CONSTRUCTION MANAGER

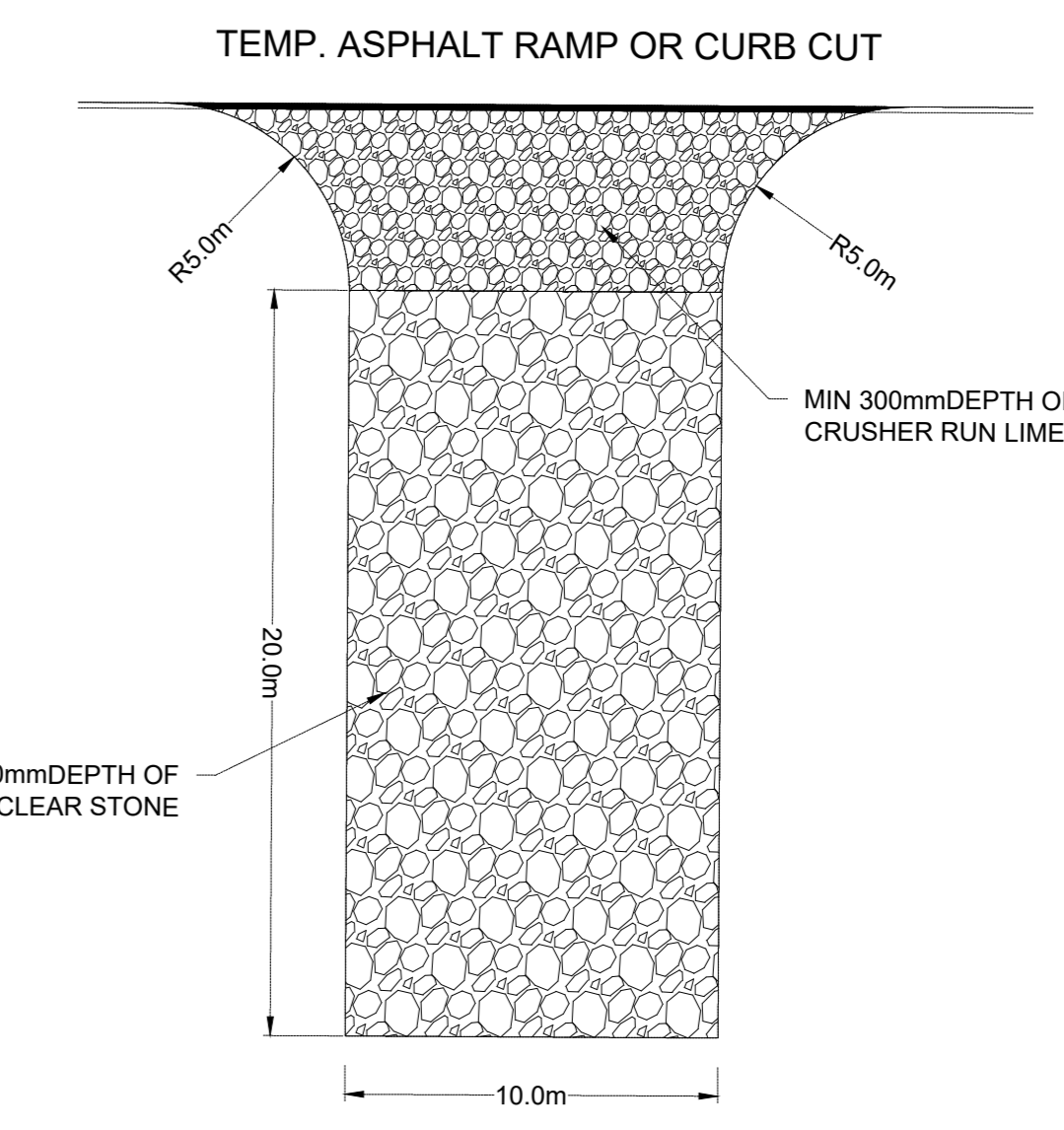

**TEMP. ASPHALT RAMP OR CURB CUT**  
N.T.S.

- NOTES:**
- INSTALL AT ALL SITE ACCESS LOCATIONS.
  - TEMPORARY CONSTRUCTION ACCESS SHALL BE REMOVED ON COMPLETION OF THE WORK AND ALL DISTURBED AREAS SHALL BE RESTORED TO ORIGINAL OR BETTER CONDITION.

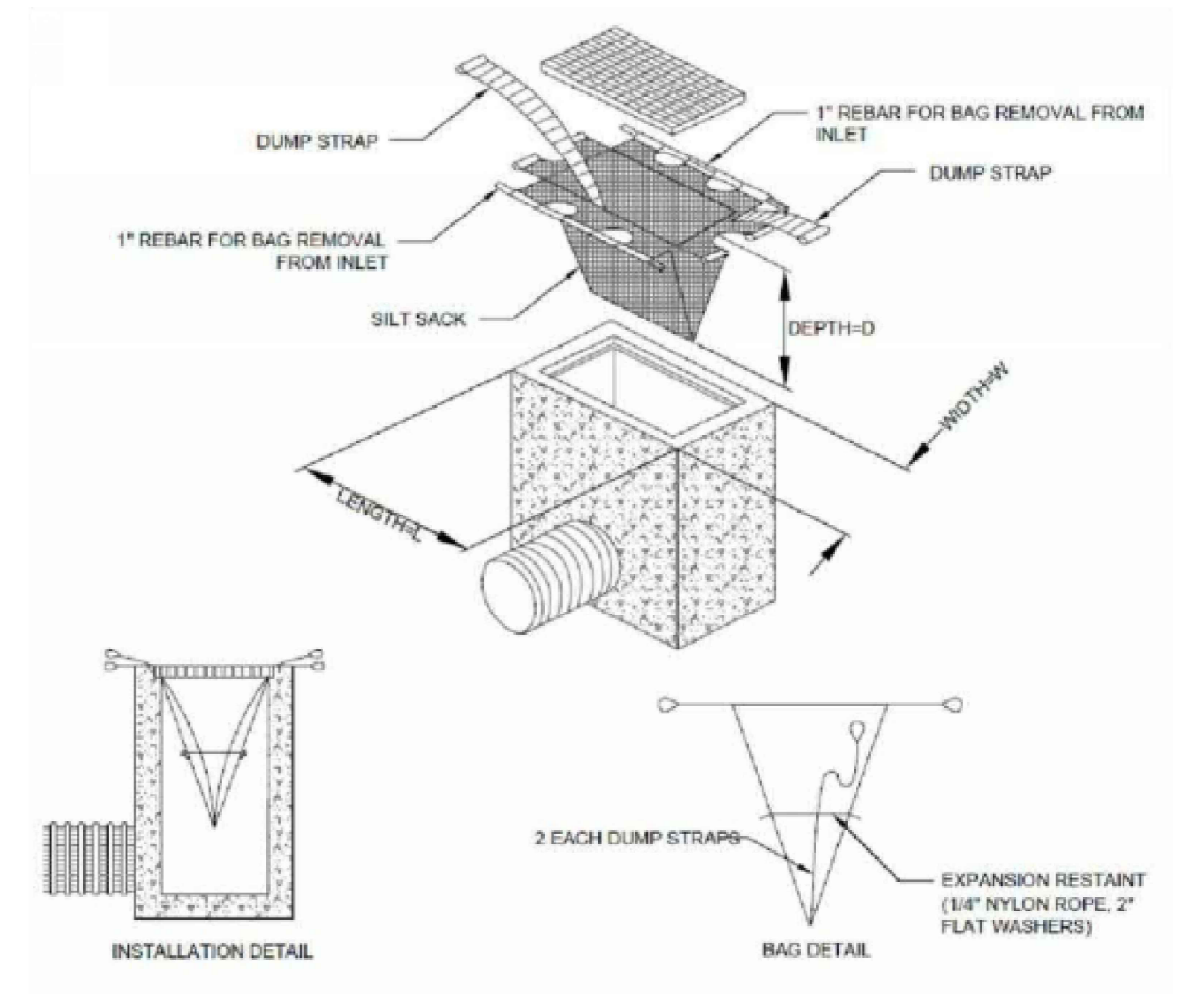

**INLET SEDIMENT CONTROL DEVICE**  
N.T.S.

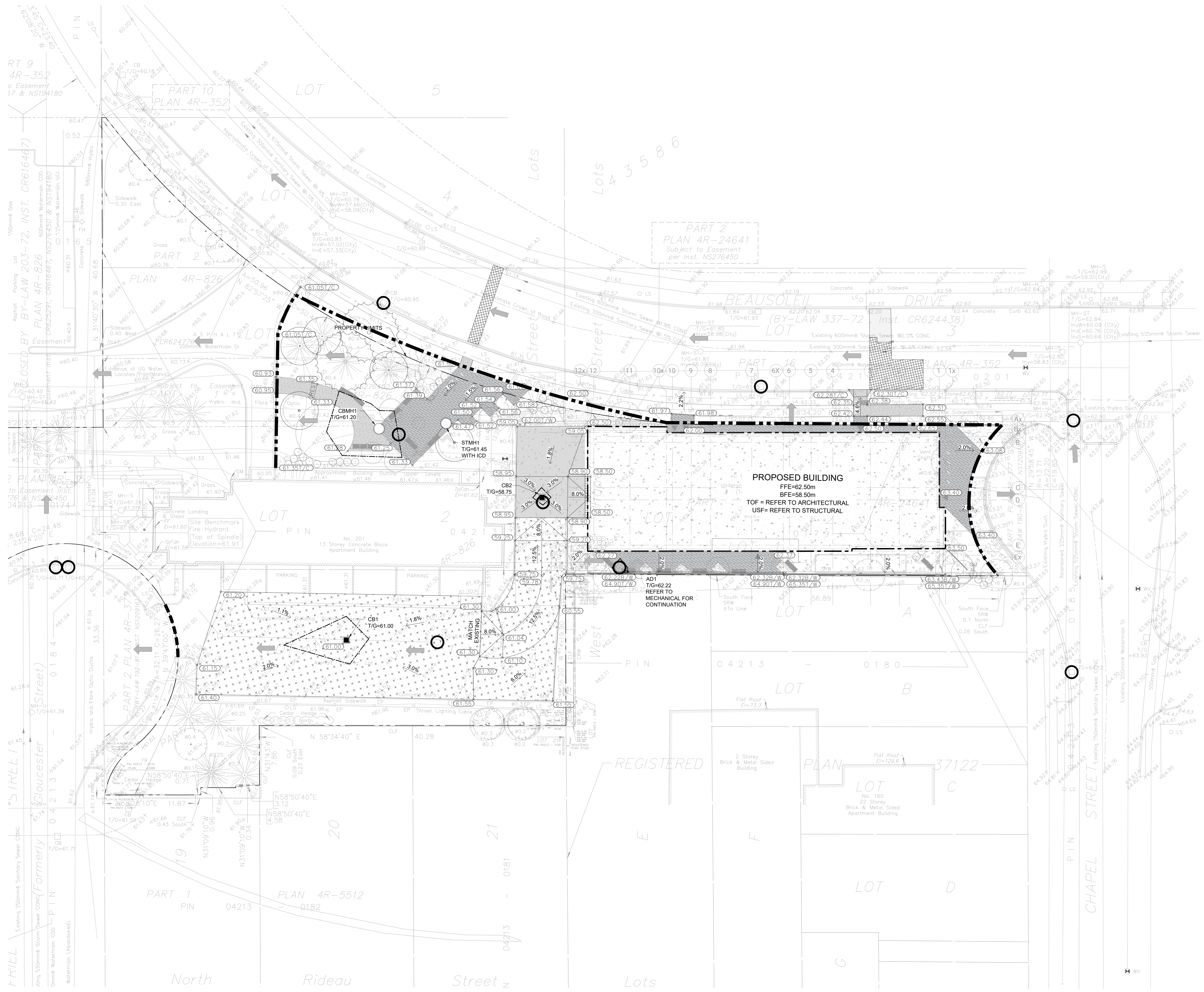

- EROSION AND SEDIMENT CONTROL**
- THE CONTRACTOR SHALL IMPLEMENT BEST MANAGEMENT PRACTICES, TO PROVIDE FOR PROTECTION OF THE AREA DRAINAGE SYSTEM AND THE RECEIVING WATERCOURSE. DURING CONSTRUCTION ACTIVITIES THIS INCLUDES LIMITING THE AMOUNT OF EXPOSED SOIL, USING CATCH BASIN SEDIMENT PROTECTION AND INSTALLING SILT FENCES AND OTHER EFFECTIVE SEDIMENT TRAPS. THE CONTRACTOR ACKNOWLEDGES THAT FAILURE TO IMPLEMENT APPROPRIATE EROSION AND SEDIMENT CONTROL MEASURES MAY BE SUBJECT TO PENALTIES IMPOSED BY ANY APPLICABLE REGULATORY AGENCY.
  - EROSION AND SEDIMENT CONTROL MEASURES ARE TO BE IMPLEMENTED PRIOR TO CONSTRUCTION AND REMAIN IN PLACE UNTIL VEGETATION IS ESTABLISHED.
  - REGULAR INSPECTION AND MAINTENANCE OF THE EROSION AND SEDIMENT MEASURES SHALL BE UNDERTAKEN. THE IMPLEMENTATION AND ADJUSTMENT AND/OR CORRECTIVE MAINTENANCE OF THE EROSION AND SEDIMENT MEASURES IS AN INTEGRAL PART OF THE PLAN AND MUST BE PERFORMED.
  - CONTRACTOR IS RESPONSIBLE TO KEEP THE ROADS FREE AND CLEAN FROM MUD AND DEBRIS, AS A MINIMUM THIS SHALL INCLUDE SWEEPING LIBRARY ROAD DAILY DURING EXCAVATION WORK.
  - THE SEDIMENT AND EROSION CONTROL MEASURES MAY BE MODIFIED IN THE FIELD AT THE DISCRETION OF THE CITY OF OTTAWA SITE INSPECTOR OR CONSERVATION AUTHORITY.

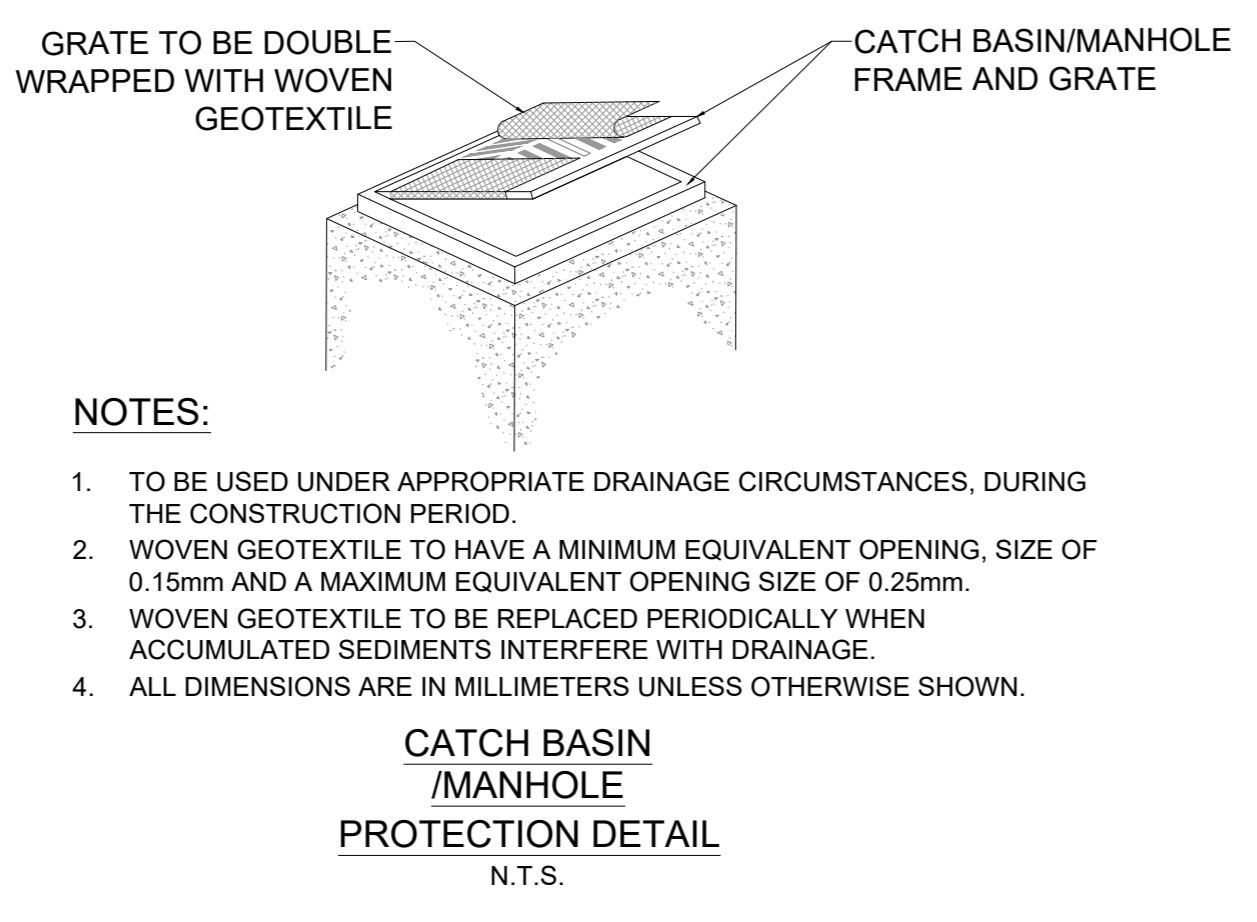

- NOTES:**
- TO BE USED UNDER APPROPRIATE DRAINAGE CIRCUMSTANCES, DURING THE CONSTRUCTION PERIOD.
  - WOVEN GEOTEXTILE TO HAVE A MINIMUM EQUIVALENT OPENING SIZE OF 0.15mm AND A MAXIMUM EQUIVALENT OPENING SIZE OF 0.25mm.
  - WOVEN GEOTEXTILE TO BE REPLACED PERIODICALLY WHEN ACCUMULATED SEDIMENTS INTERFERE WITH DRAINAGE.
  - ALL DIMENSIONS ARE IN MILLIMETERS UNLESS OTHERWISE SHOWN.

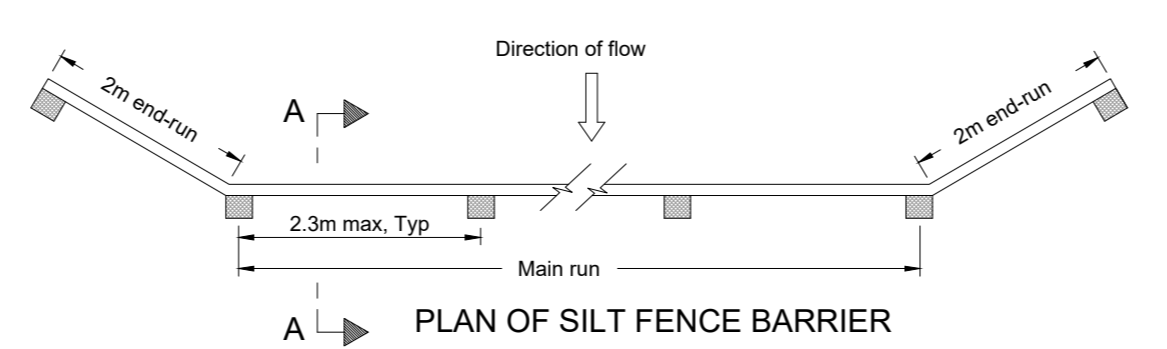

- NOTES:**
- WOVEN GEOTEXTILE TO HAVE A MINIMUM EQUIVALENT OPENING SIZE OF 0.15mm AND A MAXIMUM EQUIVALENT OPENING SIZE OF 0.25mm.
  - WOVEN GEOTEXTILE TO HAVE A HORIZONTAL OVERLAP OF 100mm AT JOINTS.
  - ALL DIMENSIONS ARE IN MILLIMETERS UNLESS OTHERWISE SHOWN.

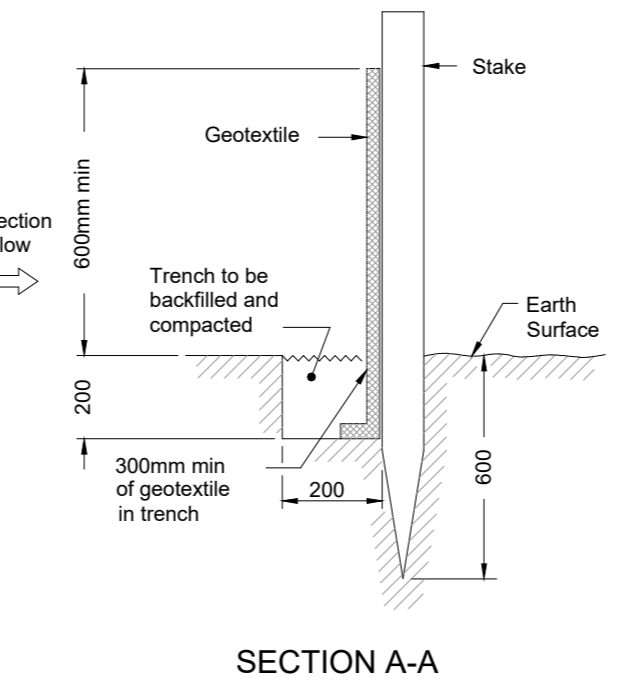

**LIGHT DUTY SILT FENCE BARRIER**  
AS PER OPSD 219.110  
N.T.S.

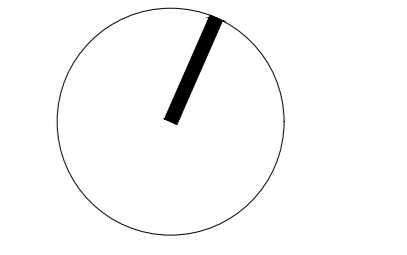

CONTRACTOR MUST CHECK & VERIFY ALL DIMENSIONS ON THE JOB. 50:40 SCALE DRAWING.  
ALL DRAWINGS, SPECIFICATIONS AND RELATED DOCUMENTS ARE THE COPYRIGHT PROPERTY OF THE ARCHITECT AND MUST BE RETURNED UPON REQUEST. REPRODUCTION OF DRAWINGS, SPECIFICATIONS AND RELATED DOCUMENTS IN PART OR IN WHOLE IS FORBIDDEN WITHOUT THE WRITTEN PERMISSION OF THE ARCHITECT.  
THIS DRAWING IS NOT TO BE USED FOR CONSTRUCTION UNLESS SIGNED BY THE ARCHITECT.

**OCH FRIEL STREET / CHAPEL**  
200201 FRIEL STREET  
221021

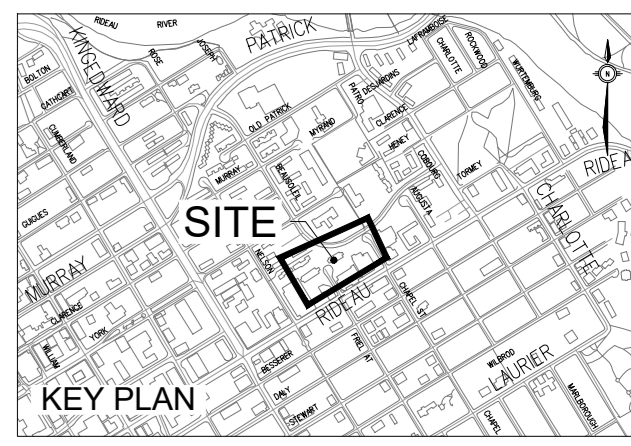

ISSUED  
No. Date Description  
0 2023 MAR 22 ISSUED FOR SITE PLAN APPROVAL  
1 2023 MAY 12 ISSUED FOR 100% SCHEMATIC DESIGN  
2 2023 MAY 18 ISSUED FOR REZONING AND SITE PLAN CONTROL - RESUBMISSION #1

**INSULATION REFERENCE TABLE**

DISTANCE FROM C.B. OR V.M. WALL	REQUIRED INSULATION THICKNESS (TYPICAL)
2400 - 3000 mm	50 mm
900 - 2400 mm	75 mm
300 - 900 mm	100 mm
100 - 300 mm	125 mm

**NOTES:**  
1. FOR WATERMAIN & SERVICES IN PROXIMITY TO CATCHBASINS MAINTENANCE HOLES, COLLECTS, ETC., SHALL BE TO THE WATERMAIN.  
2. STAGGER JOINTS OF MULTIPLE SHEETS.  
3. ALL DIMENSIONS ARE IN MILLIMETRES UNLESS SHOWN OTHERWISE.  
4. INSULATION CAN BE AT EITHER LOCATION OR BOTH.

**Ottawa** THERMAL INSULATION OF WATERMAINS AT OPEN STRUCTURES  
DATE: MAY 2021  
REV: FEB 2024  
DWG. No.: W23

**VALVE BOX ASSEMBLY**

**NOTES:**  
1. ALL DIMENSIONS ARE IN MILLIMETRES UNLESS SHOWN OTHERWISE.  
2. FOR 200 AND 300mm DI VALVES ADD BEDDING BELOW THE CONCRETE BLOCKS AS REQUIRED TO RAISE BELL HIGH ENOUGH TO PREVENT CONTACT WITH THE VALVE BODY.

**Ottawa** VALVE BOX ASSEMBLY  
DATE: MAY 2021  
REV: MARCH 2019  
DWG. No.: W24

**SECTION A - A**

**NOTES:**  
1. FOR WATERMAIN 100mm (NOMINAL) TO 400mm (NOMINAL).  
2. BARREL TO INVERT SEPARATION (S) SHALL BE 200mm MINIMUM.  
3. THRUST BLOCKS FOR MAINS LARGER THAN 400mm (NOMINAL) SHALL BE PER SPECIAL DESIGN.  
4. CONCRETE FOR THRUST BLOCKS SHALL BE 20 MPa.  
5. REFER TO W2.3 FOR RESTRAINED LENGTH REQUIREMENTS.  
6. REFER TO W2.3 AND W2.4 FOR THRUST BLOCK REQUIREMENTS.  
7. ALL DIMENSIONS ARE IN MILLIMETRES UNLESS SHOWN OTHERWISE.  
8. DESIGNED TO MEET THE INTENT OF THE SOIL WATERMAIN DESIGN CRITERIA JUNE 2012.

**Ottawa** WATERMAIN CROSSING BELOW SEWER  
DATE: MAY 2021  
REV: MARCH 2023  
DWG. No.: W25

**SECTION A - A**

**NOTES:**  
1. FOR WATERMAIN 100mm (NOMINAL) TO 400mm (NOMINAL).  
2. BARREL TO INVERT SEPARATION (S) SHALL BE 200mm MINIMUM.  
3. THRUST BLOCKS FOR MAINS LARGER THAN 400mm (NOMINAL) SHALL BE PER SPECIAL DESIGN.  
4. CONCRETE FOR THRUST BLOCKS SHALL BE 20 MPa.  
5. REFER TO W2.3 FOR RESTRAINED LENGTH REQUIREMENTS.  
6. REFER TO W2.3 AND W2.4 FOR THRUST BLOCK REQUIREMENTS.  
7. ALL DIMENSIONS ARE IN MILLIMETRES UNLESS SHOWN OTHERWISE.  
8. DESIGNED TO MEET THE INTENT OF THE SOIL WATERMAIN DESIGN CRITERIA JUNE 2012.

**Ottawa** WATERMAIN CROSSING OVER SEWER  
DATE: MAY 2021  
REV: MARCH 2023  
DWG. No.: W25.2

**CONCRETE THRUST BLOCKS FOR PVC AND DI PIPE 400mm AND UNDER**

**NOTES:**  
1. CONCRETE SHALL BE PLACED TO WITHIN 50mm OF FACE OF THE BELL.  
2. BOND BREAKER TO BE USED BETWEEN CONCRETE AND FITTING.  
3. ALL DIMENSIONS ARE IN MILLIMETRES UNLESS OTHERWISE SHOWN.  
4. REFER TO W2.3 FOR ADDITIONAL REQUIREMENTS.  
5. THRUST BLOCKS SHALL BE 20 MPa CONCRETE AND AS SHOWN ON ABOVE DRAWINGS UNLESS OTHERWISE DIRECTED BY THE CONTRACT ADMINISTRATOR. THE BLOCK SHALL BE CENTERED ON THE THRUST FORCE AND SHALL ALSO PARTIALLY COVER THE FITTING TO DISTRIBUTE THE FORCE. THE SOLE OF THE BLOCK SHALL BE 80mm FROM THE JOINT ON EITHER SIDE OF THE BELL OR TEE.  
6. THE CONCRETE WHERE POSSIBLE SHALL BE PLACED AGAINST UNDISTURBED SOIL AT THE BOTTOM AND SIDE OF THE TRENCH WHERE IT IS NOT POSSIBLE THE FALL BETWEEN THE BEARING SURFACE AND THE UNDISTURBED SOIL MUST BE COMPACTED IN ACCORDANCE WITH D-029.  
7. EXCEPT FOR THE ADDITION OF WATER CONCRETE FOR THRUST BLOCKS SHALL COME FROM READY-MIXED CONCRETE SUPPLIER. ALL READY-MIXED CONCRETE SHALL BE PLACED IN A CLEAN, SAND AND AGGREGATE ETC. BY THE CONTRACTOR FOR THE PURPOSE OF MAKING CONCRETE THRUST BLOCKS. WEDGERS SHALL NOT BE ACCEPTED.

**Ottawa** CONCRETE THRUST BLOCKS FOR PVC AND DI PIPE 400mm AND UNDER  
DATE: MAY 2021  
REV: MARCH 2020  
DWG. No.: W25.3

**SOILS WITH TYPICAL BEARING STRENGTH OF 100 TO 199 KPa**

PIPE DIAMETER	DIMENSION NOTED ON W25.3			
	A	B	C	D
102	250	250	200	200
152	400	400	250	300
203	550	550	300	450
254	650	650	400	500
305	800	800	450	650
406	1050	1050	600	850

**SOILS WITH TYPICAL BEARING STRENGTH OF 200 TO 299 KPa**

PIPE DIAMETER	DIMENSION NOTED ON W25.3			
	A	B	C	D
102	200	200	150	150
152	250	250	200	200
203	350	350	250	270
254	450	450	300	350
305	500	500	350	400
406	750	750	400	600

**SOILS WITH TYPICAL BEARING STRENGTH OF 300 KPa AND OVER**

PIPE DIAMETER	DIMENSION NOTED ON W25.3			
	A	B	C	D
102	150	150	150	150
152	200	200	200	200
203	300	300	200	230
254	400	400	250	270
305	450	450	300	300
406	650	650	350	450

**NOTES:**  
1. THE ABOVE THRUST BLOCK DIMENSIONS MEET OR EXCEED THE WATERMAIN DESIGN CRITERIA FOR FUTURE ALTERATIONS AUTHORIZED UNDER A CONCRETE WATERWORKS PERMIT.  
2. THE ASSUMPTIONS MADE FOR THE ABOVE CALCULATIONS ARE AS FOLLOWS:  
a) MAXIMUM SURFACE PRESSURE OF 30 kPa  
b) MAXIMUM SURFACE PRESSURE WITH A FLOW VELOCITY CHANGE OF 0.8 m/s  
c) MAXIMUM SURFACE PRESSURE WITH A FLOW VELOCITY CHANGE OF 0.8 m/s  
3. THE TABLES APPLY TO BOTH DUCTILE IRON AND PVC, WHERE ONE LENGTH EXCEEDED THE OTHER THE LONGER LENGTH WAS USED.  
4. DIMENSIONS MAY BE REDUCED TO LONG AS THE BEARING SURFACE AREA OF THE THRUST BLOCK IS NOT REDUCED.  
5. TO BE USED IN CONJUNCTION WITH W2.3.

**Ottawa** THRUST BLOCK DIMENSION TABLES FOR PVC AND DI PIPE 400mm AND UNDER  
DATE: MAY 2021  
REV: MARCH 2011  
DWG. No.: W25.4

**RESTRAINING AND RETAINING RINGS FOR PVC AND DI PIPE 400mm AND UNDER**

**NOTES:**  
1. ANY JOINT THAT FALLS WITHIN THE RESTRAINED LENGTH (L) SHALL BE RESTRAINED SEE DRAWING W20.4  
2. TO REDUCE THE NUMBER OF RESTRAINTS REQUIRED THE USE OF FULL PIPE LENGTH IS RECOMMENDED IN THESE AREAS.

**Ottawa** RESTRAINING AND RETAINING RINGS FOR PVC AND DI PIPE 400mm AND UNDER  
DATE: MAY 2021  
REV: NONE  
DWG. No.: W25.5

**TABLE OF RESTRAINED LENGTHS FOR DI AND PVC WATERMAIN PIPE IN STANDARD GRANULAR 'A' EMBEDMENT IN SOILS OF BEARING CAPACITY OF 100 KPa AND OVER**

REDUCERS	LARGER DIAMETER SIDE (TO BE RESTRAINED)				
	100mm	150mm	200mm	250mm	300mm
100mm	N/A	3	6	8	10
150mm	N/A	N/A	4	6	9
200mm	N/A	N/A	N/A	3	6
250mm	N/A	N/A	N/A	N/A	4
300mm	N/A	N/A	N/A	N/A	7
400mm	N/A	N/A	N/A	N/A	N/A

**PIPE DIAMETER**  
100mm 150mm 200mm 250mm 300mm 400mm

**DEAD ENDS, CAPS, PLUGS, VALVES**

BEFORE CAPS AND EITHER SIDE OF VALVES - L	5	6	9	10	12	16
---	---	---	---	----	----	----

**VERTICAL BENDS**

LENGTH THRU SIDE - LLS	3	4	5	6	7	9
LENGTH LOW SIDE - LLS	1.5	2	2.5	3	3.5	4.5

**TEES**

LENGTH ALONG THE BRANCH - L	1	1	1	1	1	1
LENGTH ALONG THE RUN - L <sub>r</sub>	3	3	3	3	3	3

**HORIZONTAL BENDS**

11.25, 22.5, AND 45 DEGREE BENDS	1	1.5	1.5	2	2	2.5
----------------------------------	---	-----	-----	---	---	-----

**NOTES:**  
1. THE ABOVE RESTRAINED LENGTHS MEET OR EXCEED THE WATERMAIN DESIGN CRITERIA FOR FUTURE ALTERATIONS AUTHORIZED UNDER A CONCRETE WATERWORKS PERMIT.  
2. THE ASSUMPTIONS MADE FOR THE ABOVE CALCULATIONS ARE AS FOLLOWS:  
a) MAXIMUM OPERATING PRESSURE OF 100 psig  
b) MAXIMUM SURFACE PRESSURE WITH A FLOW VELOCITY CHANGE OF 0.8 m/s  
c) MAXIMUM SURFACE PRESSURE WITH A FLOW VELOCITY CHANGE OF 0.8 m/s  
3. FOR SOFTWARE CALCULATIONS USE A TEST PRESSURE OF 180 psig AND A SAFETY FACTOR OF 1.8  
4. TYPE 'A' TRENCH BEDDING.  
5. DEPTH TO BENT 2.4 METRES EXCEPT FOR VERTICAL BENDS WHERE THE HEAD BELL IS AT 1.8 METRES.  
6. EMBEDMENT MATERIAL GRANULAR 'A' WITH CHARACTERISTICS OF ASTM D2457 GP.  
7. IF SOLE ARE DESCRIBED AS POORLY GRADED GRANULAR AND SAND-GRAVEL MIXES WITH LITTLE OR NO FINES.  
8. (U) MUST BE OF SOLID PIPE WITHOUT JOINTS, FITTINGS, ETC.  
9. THE TABLES APPLY TO BOTH DUCTILE IRON AND PVC, WHERE ONE LENGTH EXCEEDED THE OTHER THE LONGER LENGTH WAS USED.  
10. RESTRAINED LENGTH ARE IN METRES.

**Ottawa** TABLES OF RESTRAINED LENGTHS FOR PVC AND DI PIPE 400mm AND UNDER  
DATE: MAY 2021  
REV: MARCH 2011  
DWG. No.: W25.6

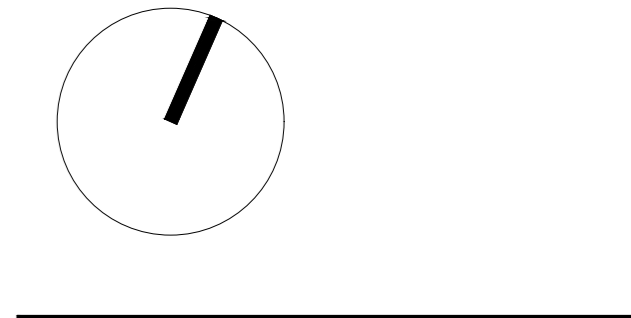
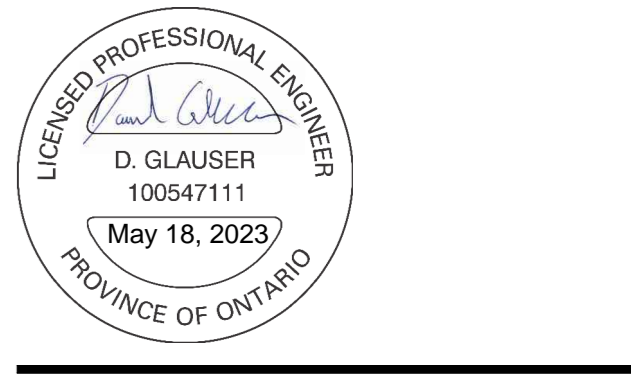

CONTRACTOR MUST CHECK AND VERIFY ALL DIMENSIONS ON THE JOB.  
ALL DRAWINGS, SPECIFICATIONS AND RELATED DOCUMENTS ARE THE PROPERTY OF THE ARCHITECT AND MUST BE RETURNED UPON REQUEST. REPRODUCTION OF DRAWINGS, SPECIFICATIONS AND RELATED DOCUMENTS IN PART OR IN WHOLE IS FORBIDDEN WITHOUT THE WRITTEN PERMISSION OF THE ARCHITECT.  
THIS DRAWING IS NOT TO BE USED FOR CONSTRUCTION UNLESS SIGNED BY THE ARCHITECT.

OCH FRIEL STREET / CHAPEL  
20001 FRIEL STREET  
221021

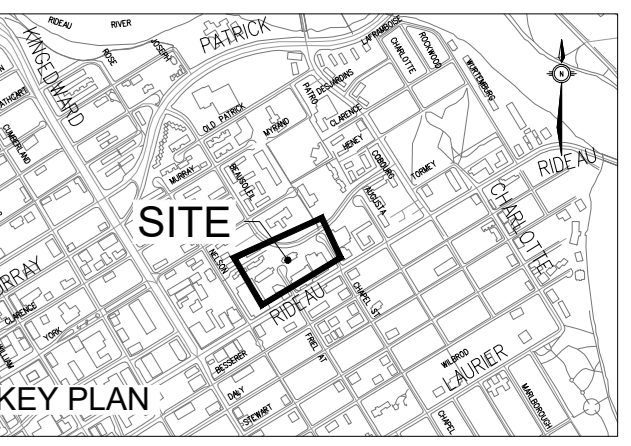

ISSUED

No.	Date	Description
0	2023 MAR 22	ISSUED FOR SITE PLAN APPROVAL
1	2023 MAY 12	ISSUED FOR 100% SCHEMATIC DESIGN
2	2023 MAY 18	ISSUED FOR REZONING AND SITE PLAN CONTROL - RESUBMISSION #1

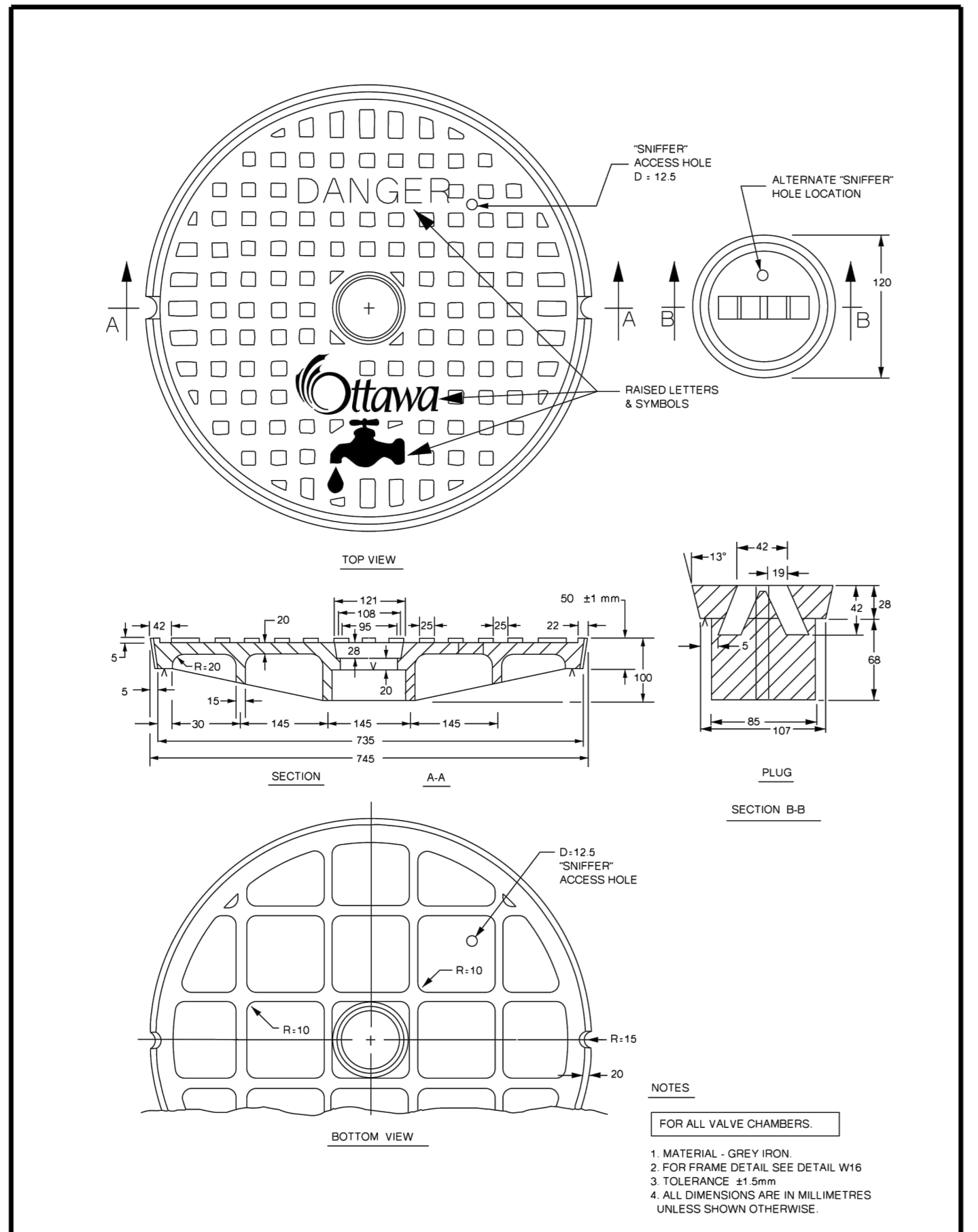

**Ottawa** STANDARD COVER FOR VALVE CHAMBERS  
DATE: MAY 2001  
REV: MARCH 2019  
DWG No.: W15

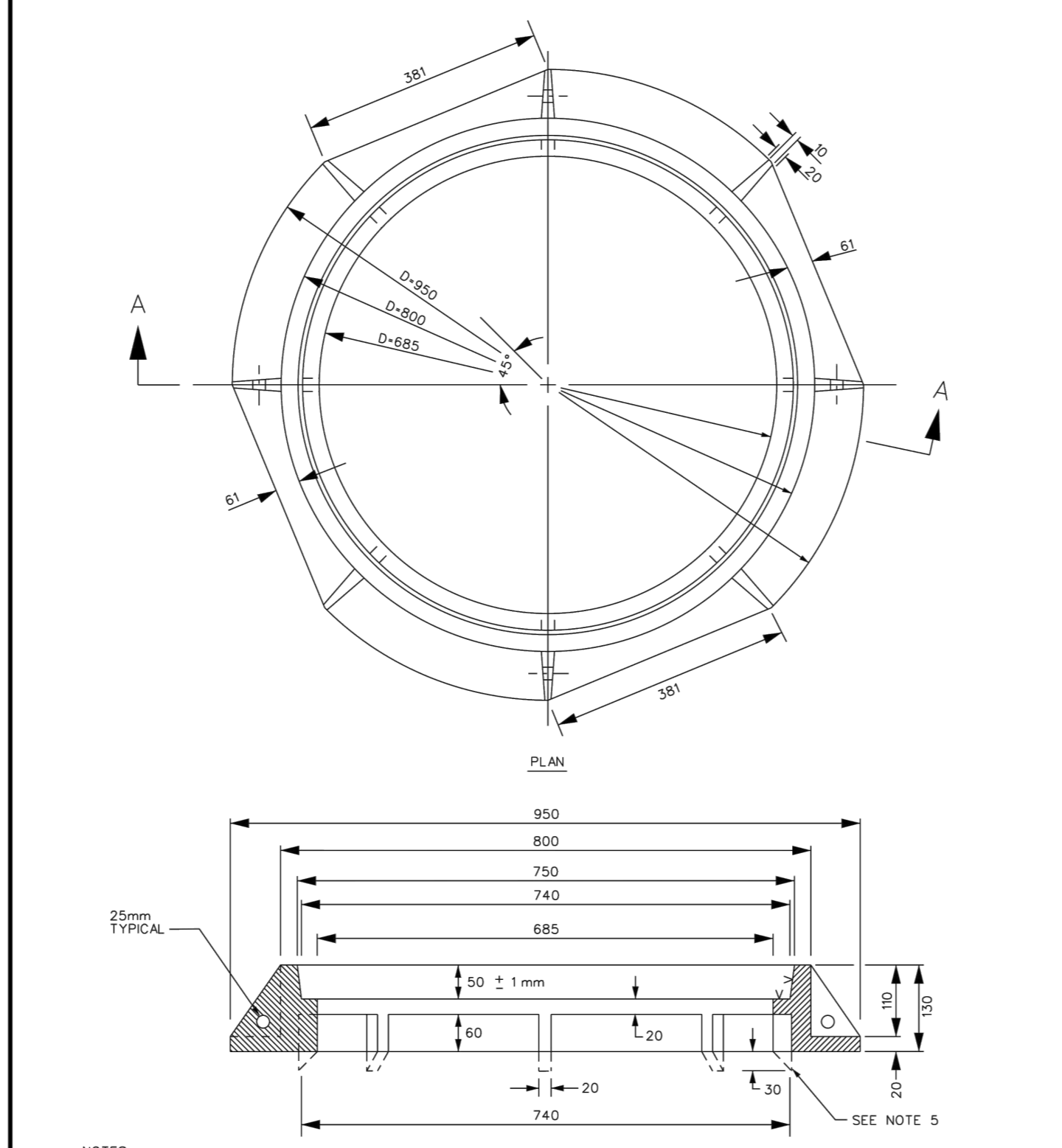

**Ottawa** STANDARD FRAME FOR VALVE CHAMBERS (MODIFIED OPSD-401.020)  
DATE: MAY 2001  
REV: MARCH 2016  
DWG No.: W16

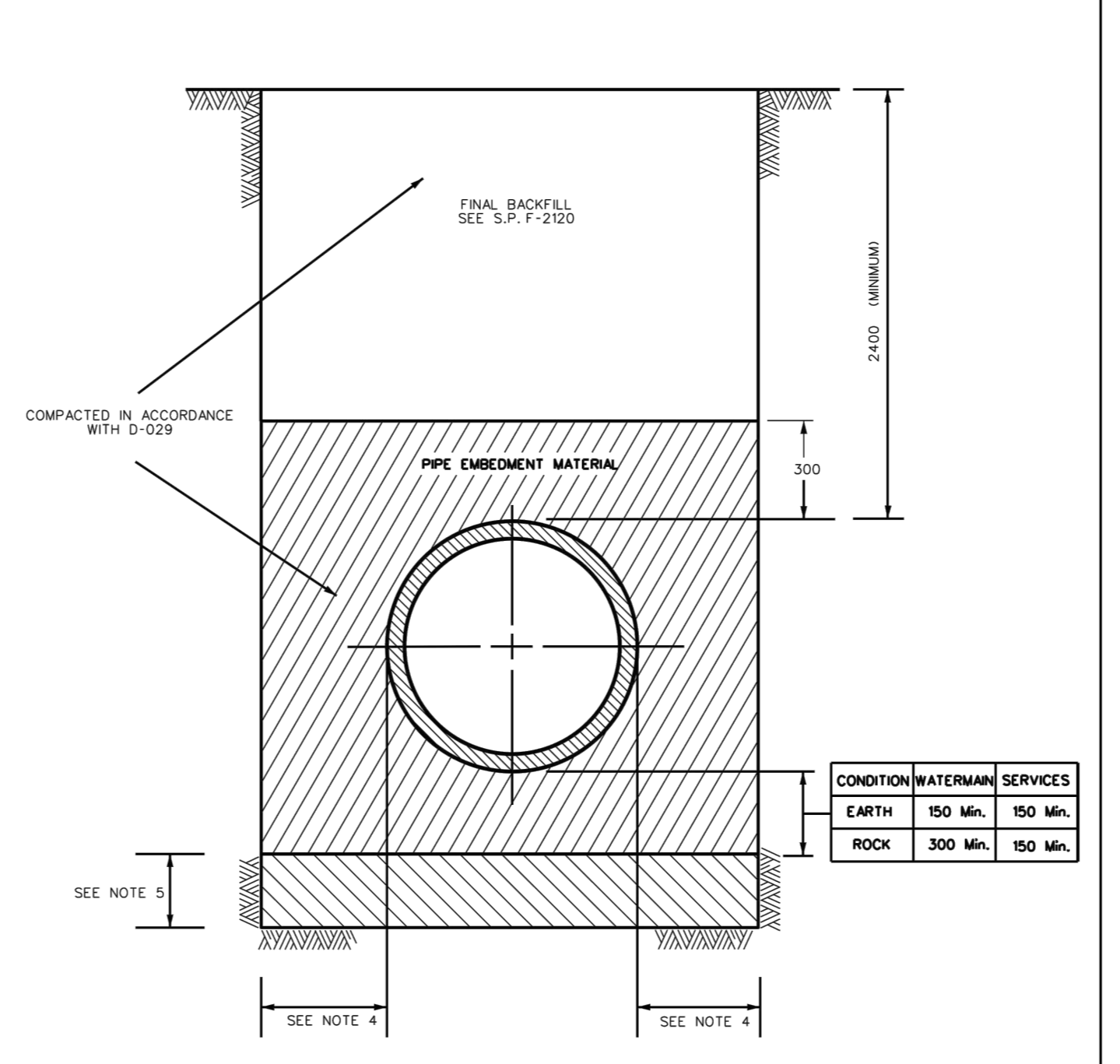

**Ottawa** STANDARD TRENCH DETAIL  
DATE: MAY 2001  
REV: MARCH 2018  
DWG No.: W17

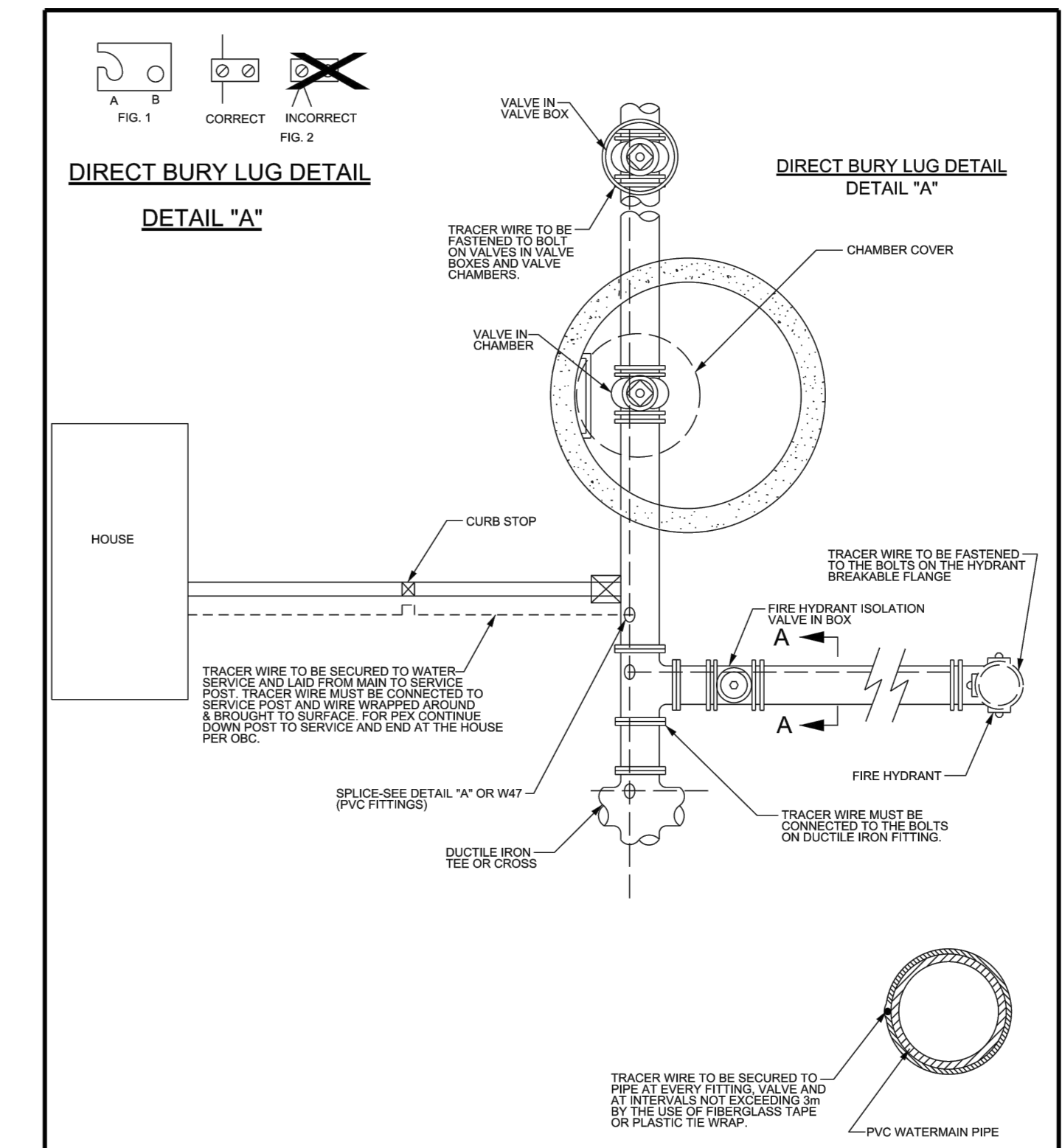

**Ottawa** TRACER WIRE INSTALLATION  
DATE: MAY 2001  
REV: MARCH 2014  
DWG No.: W36

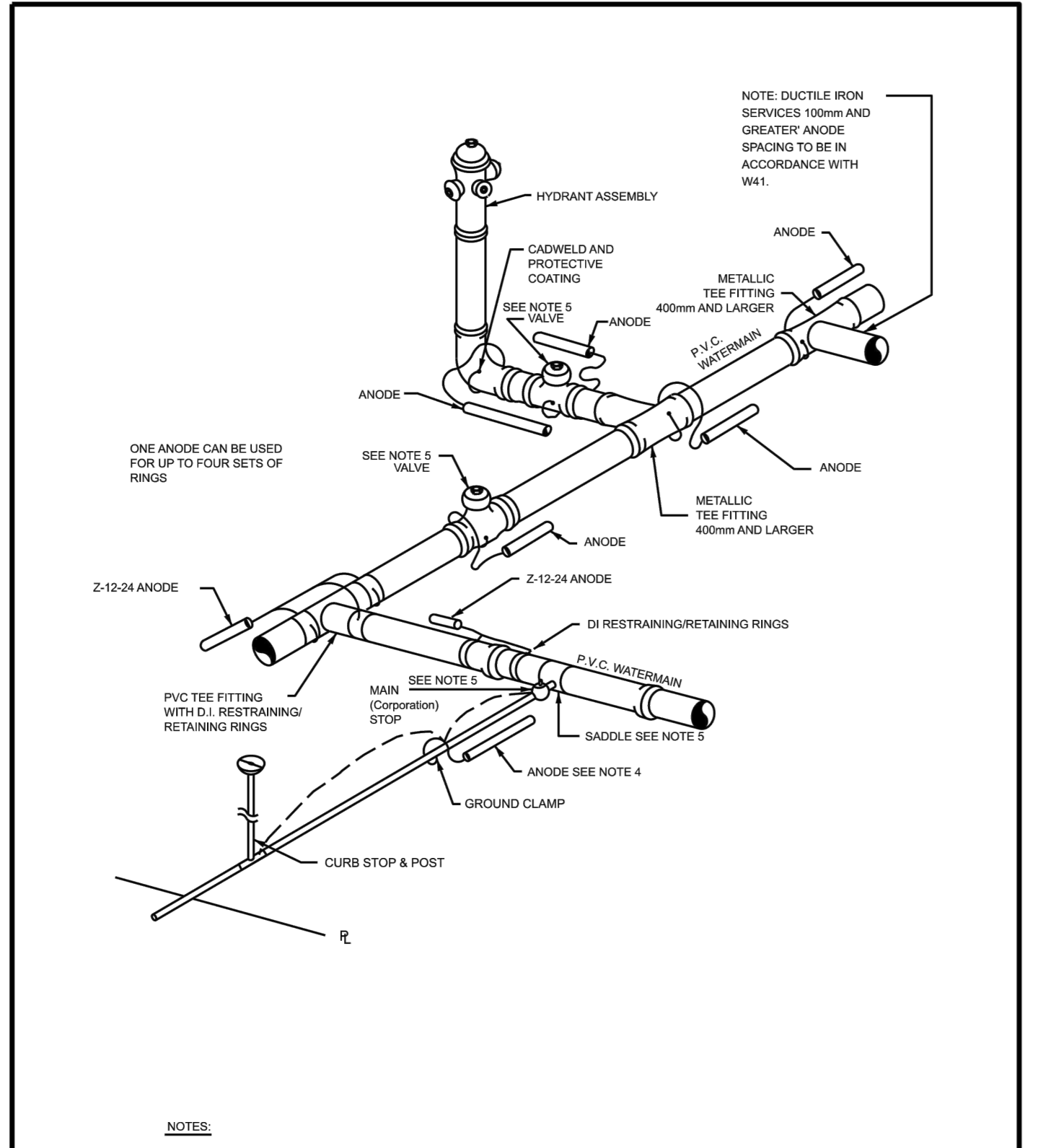

**Ottawa** CATHODIC PROTECTION FOR PVC WATERMAIN SYSTEMS  
DATE: MAY 2001  
REV: MARCH 2019  
DWG No.: W40

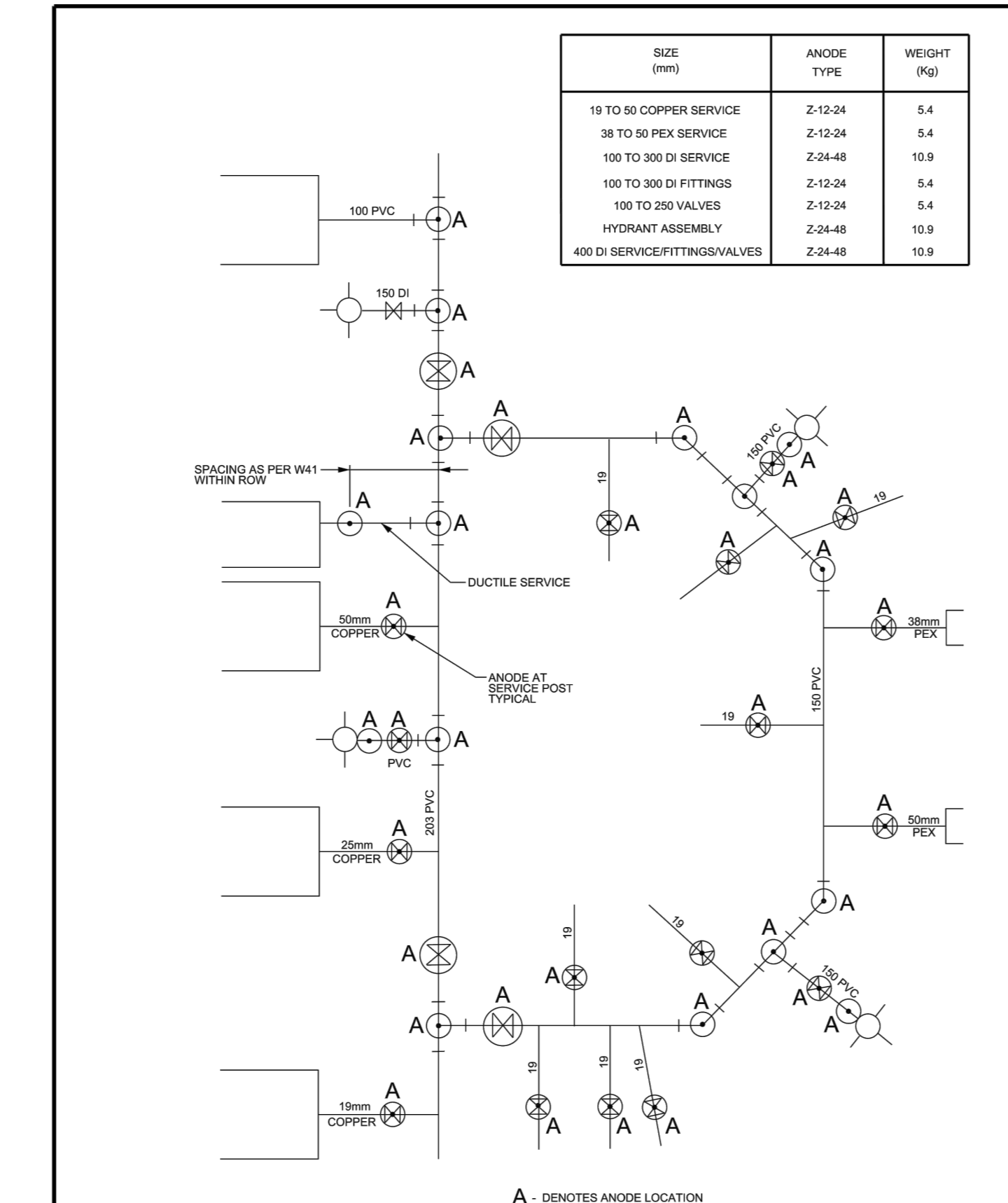

**Ottawa** TYPICAL ANODE INSTALLATION PVC WATERMAIN  
DATE: MAY 2001  
REV: MARCH 2014  
DWG No.: W42

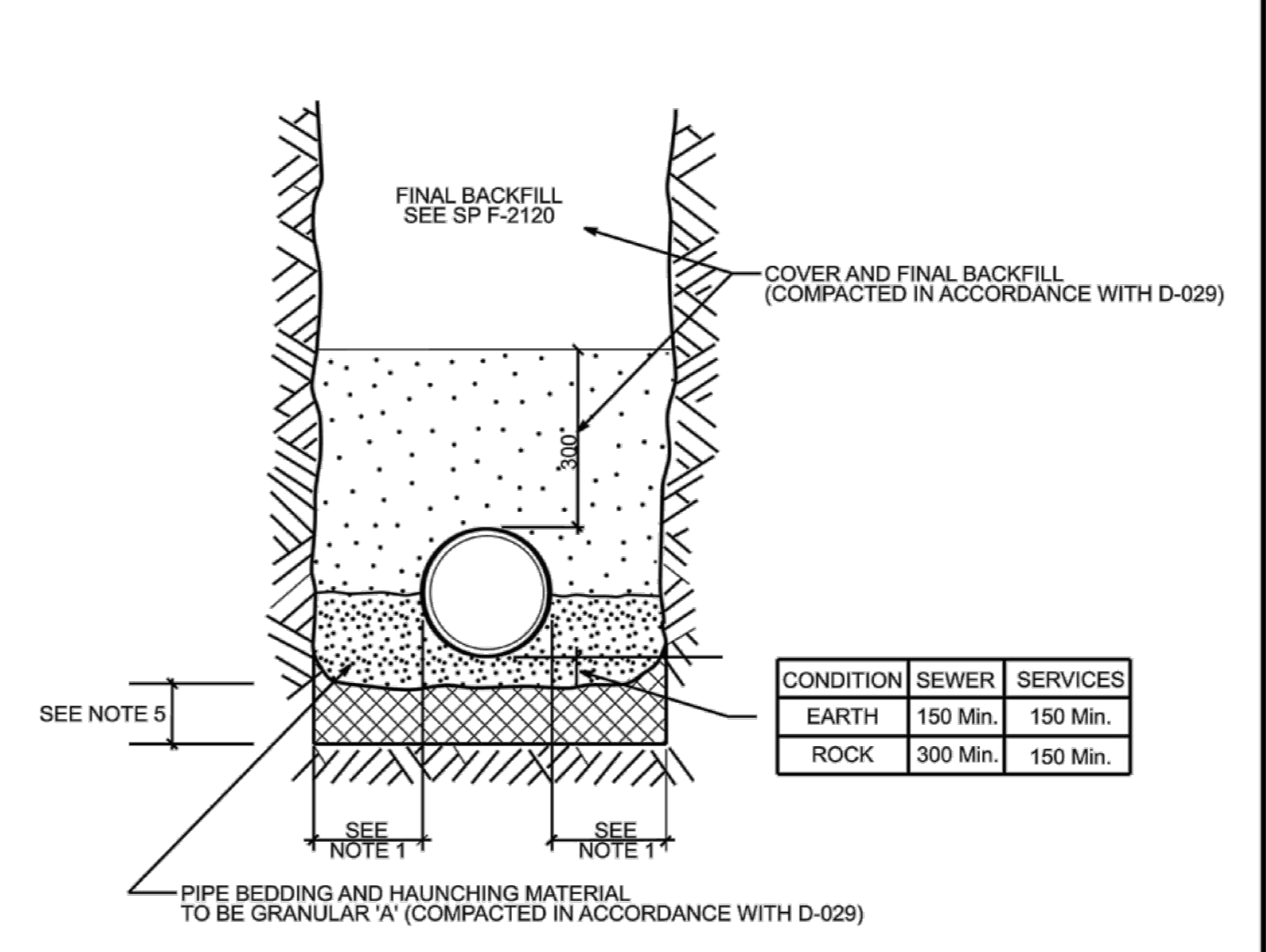

**Ottawa** SINGLE TRENCH (SEWER & SEWER SERVICES)  
DATE: MAY 2001  
REV: MARCH 2021  
DWG No.: S6

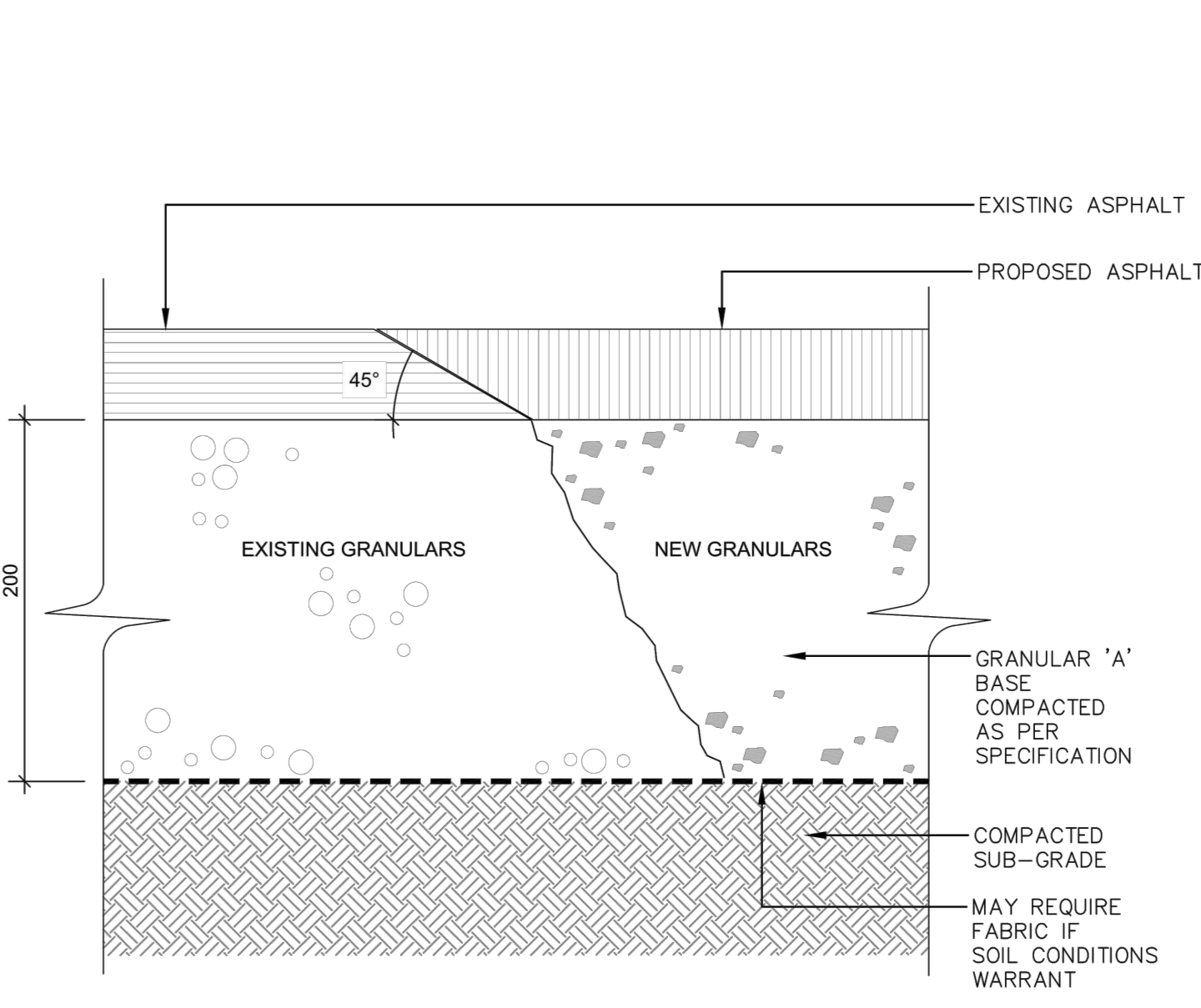

**Ottawa** ASPHALT REINSTATEMENT  
DATE: JAN 2015  
REV: MARCH 2021  
DWG No.: R25

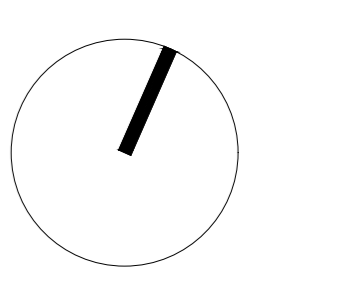
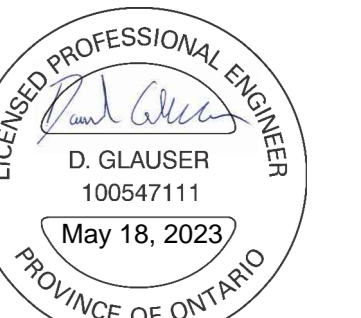

CONTRACTOR MUST CHECK & VERIFY ALL DIMENSIONS ON THE JOB. SO NOT SCALE DRAWINGS.  
ALL DRAWINGS, SPECIFICATIONS AND RELATED DOCUMENTS ARE THE COPYRIGHT PROPERTY OF THE ARCHITECT AND MUST BE RETURNED UPON REQUEST. REPRODUCTION OF DRAWINGS, SPECIFICATIONS AND RELATED DOCUMENTS IN PART OR IN WHOLE IS FORBIDDEN WITHOUT THE WRITTEN PERMISSION OF THE ARCHITECT.  
THIS DRAWING IS NOT TO BE USED FOR CONSTRUCTION UNLESS SIGNED BY THE ARCHITECT.

OCH FRIEL STREET / CHAPEL  
200201 FRIEL STREET  
221021

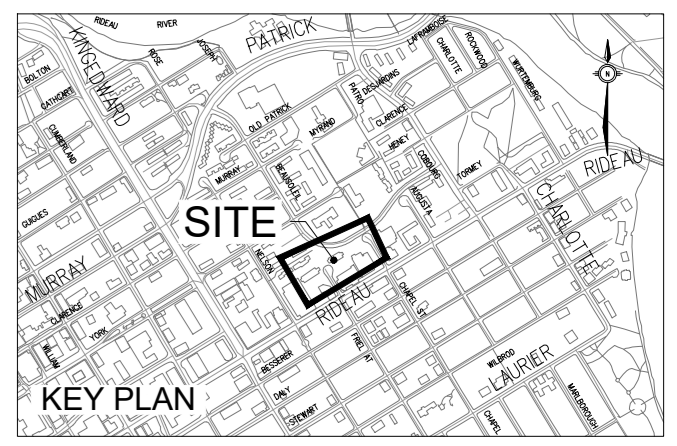

No.	Date	Description
0	2023 MAR 22	ISSUED FOR SITE PLAN APPROVAL
1	2023 MAY 12	ISSUED FOR 100% SCHEMATIC DESIGN
2	2023 MAY 18	ISSUED FOR REZONING AND SITE PLAN CONTROL - RESUBMISSION #1

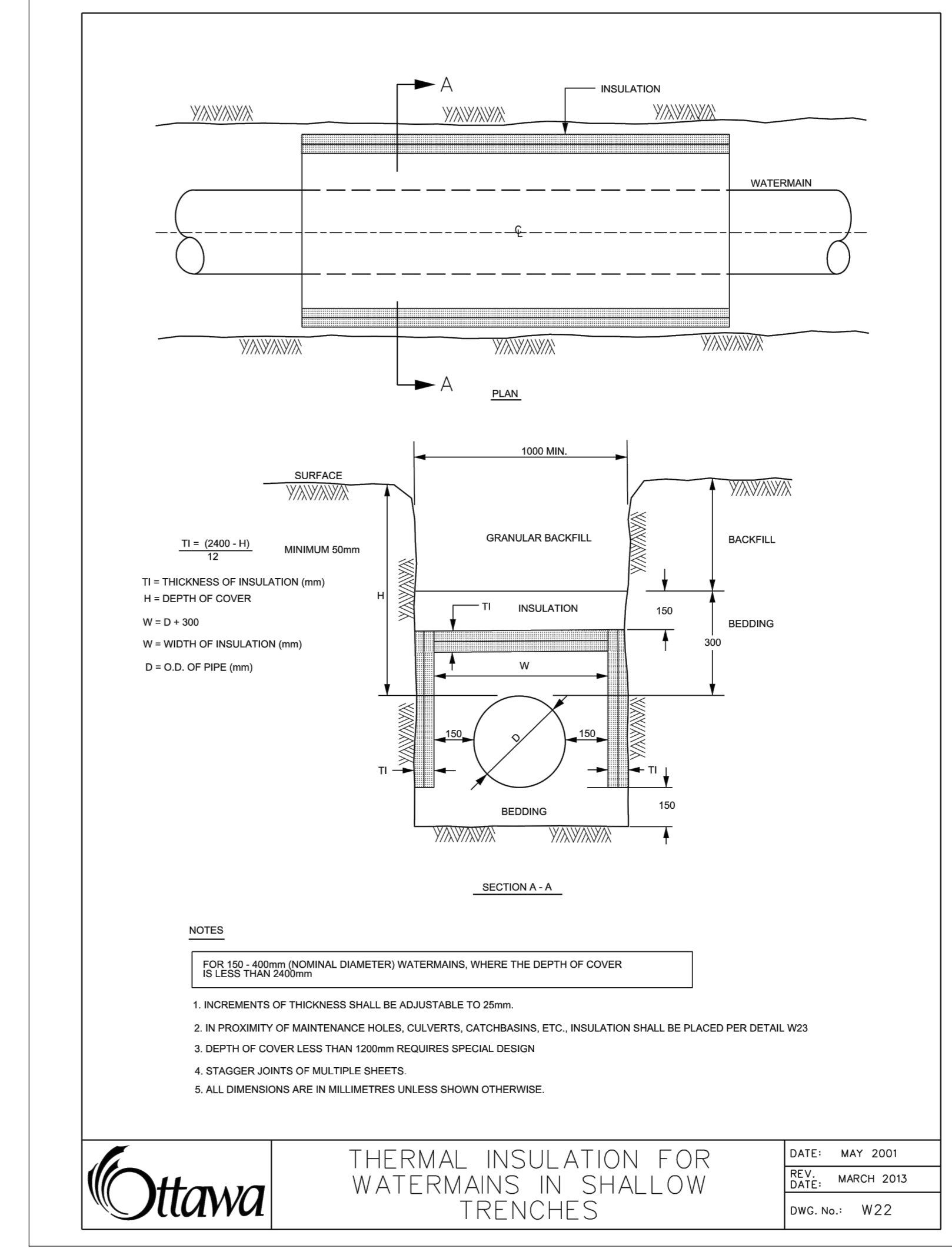
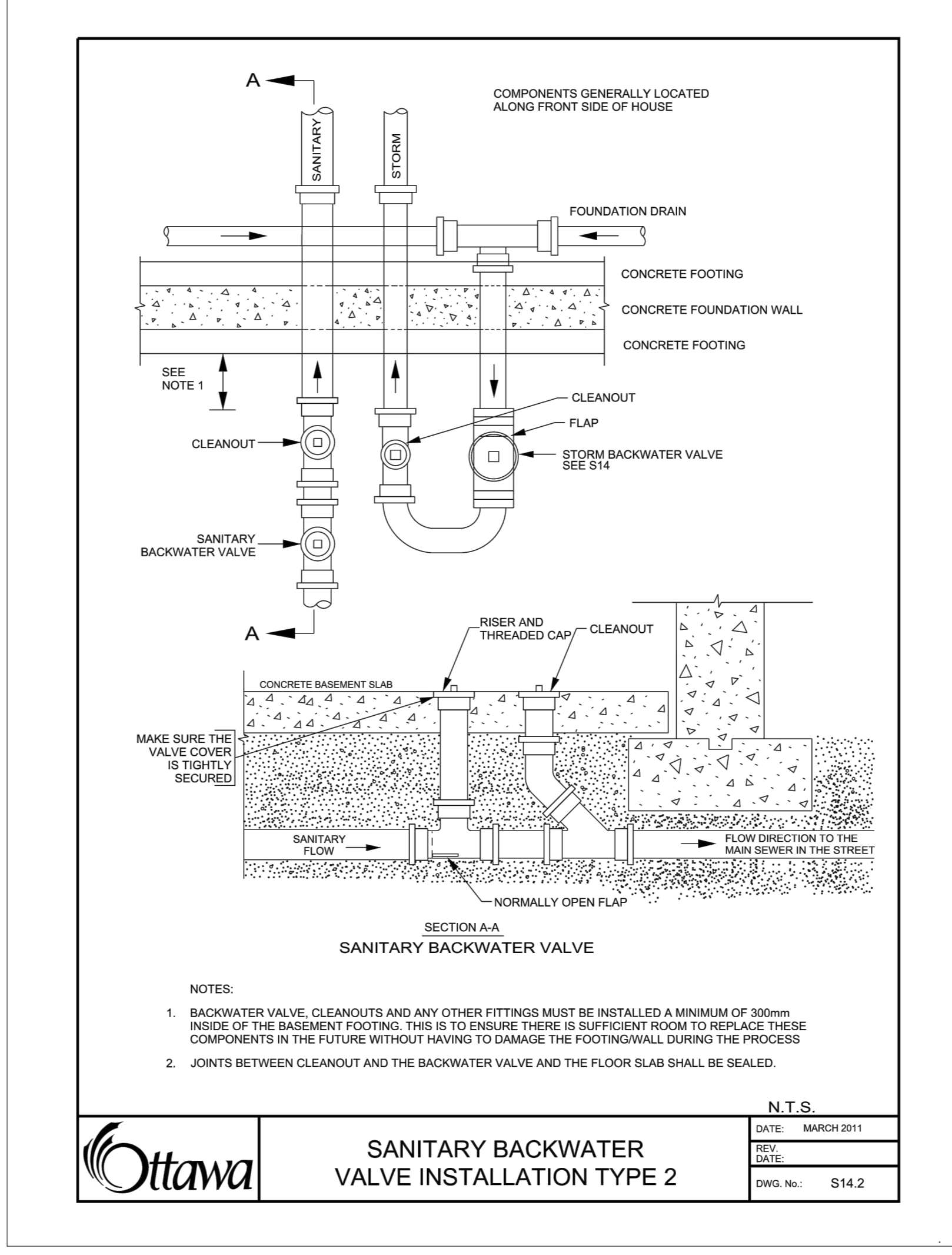
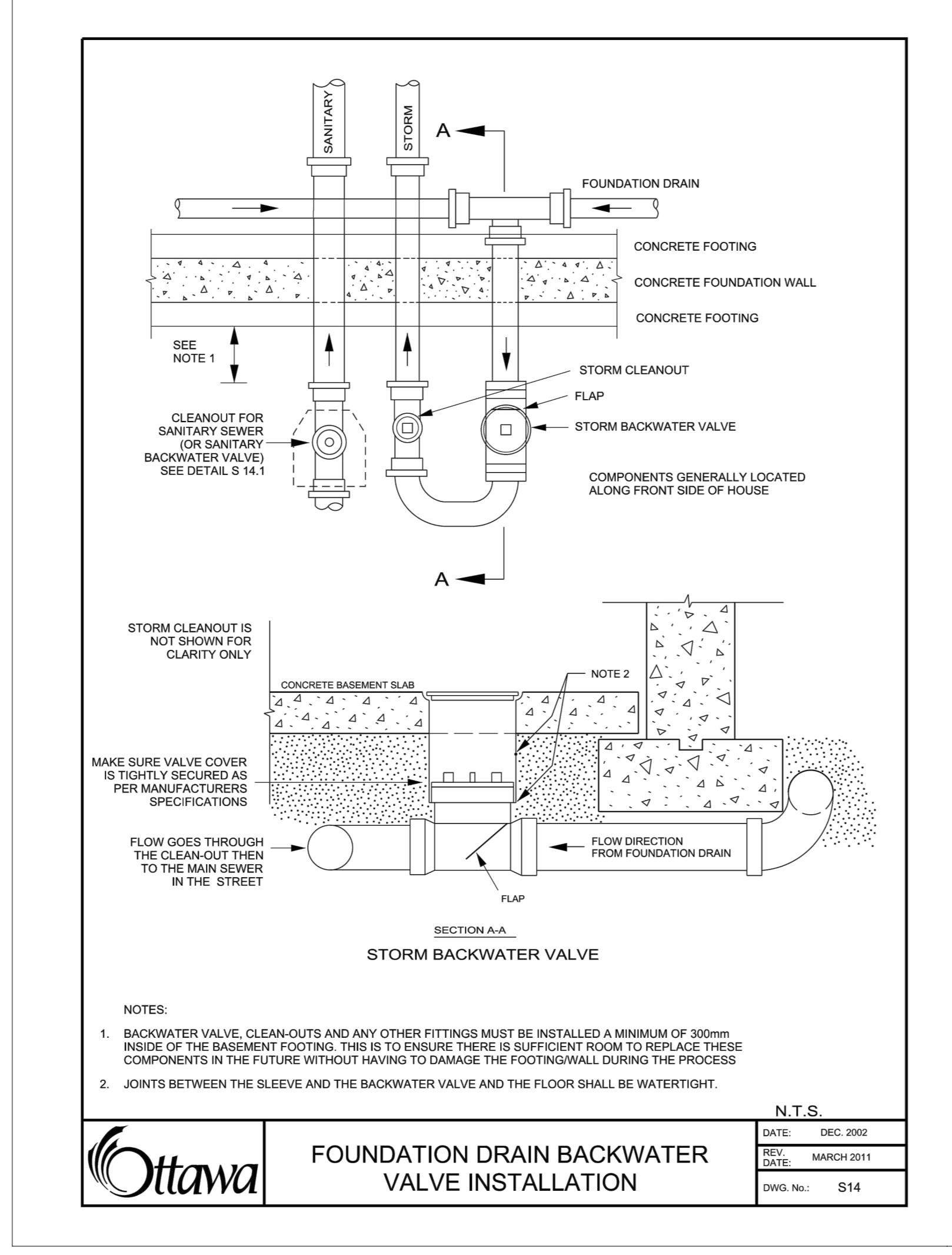
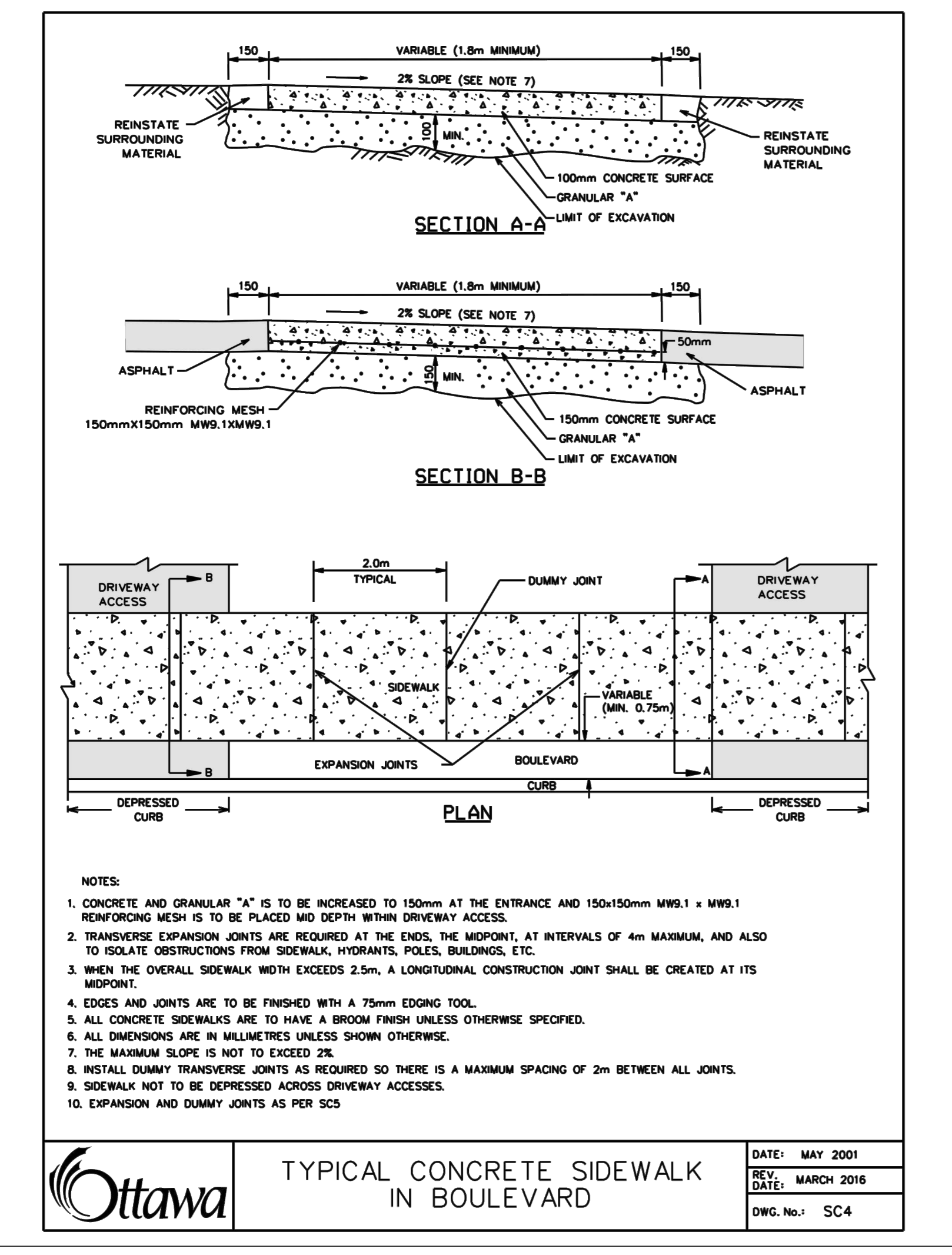
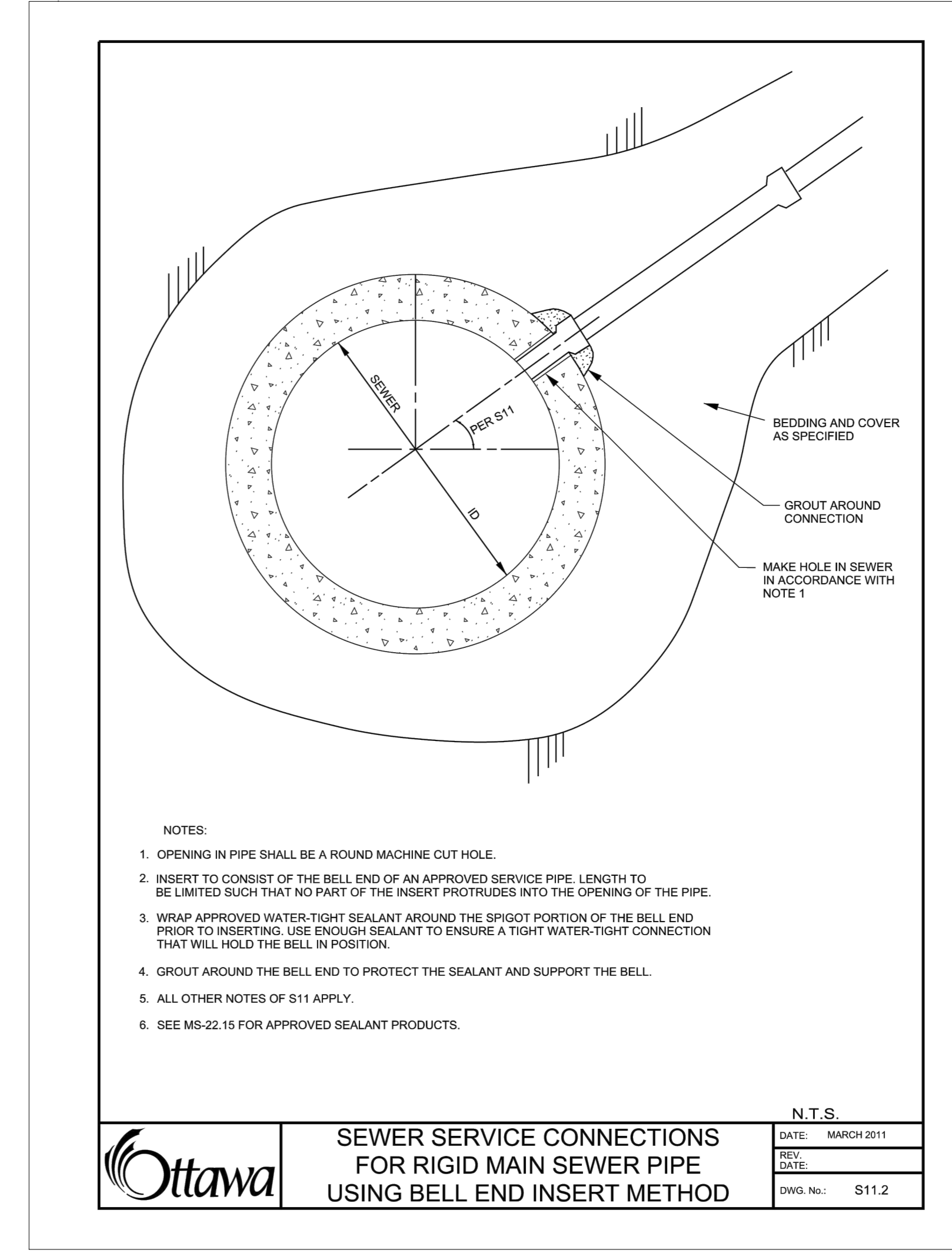
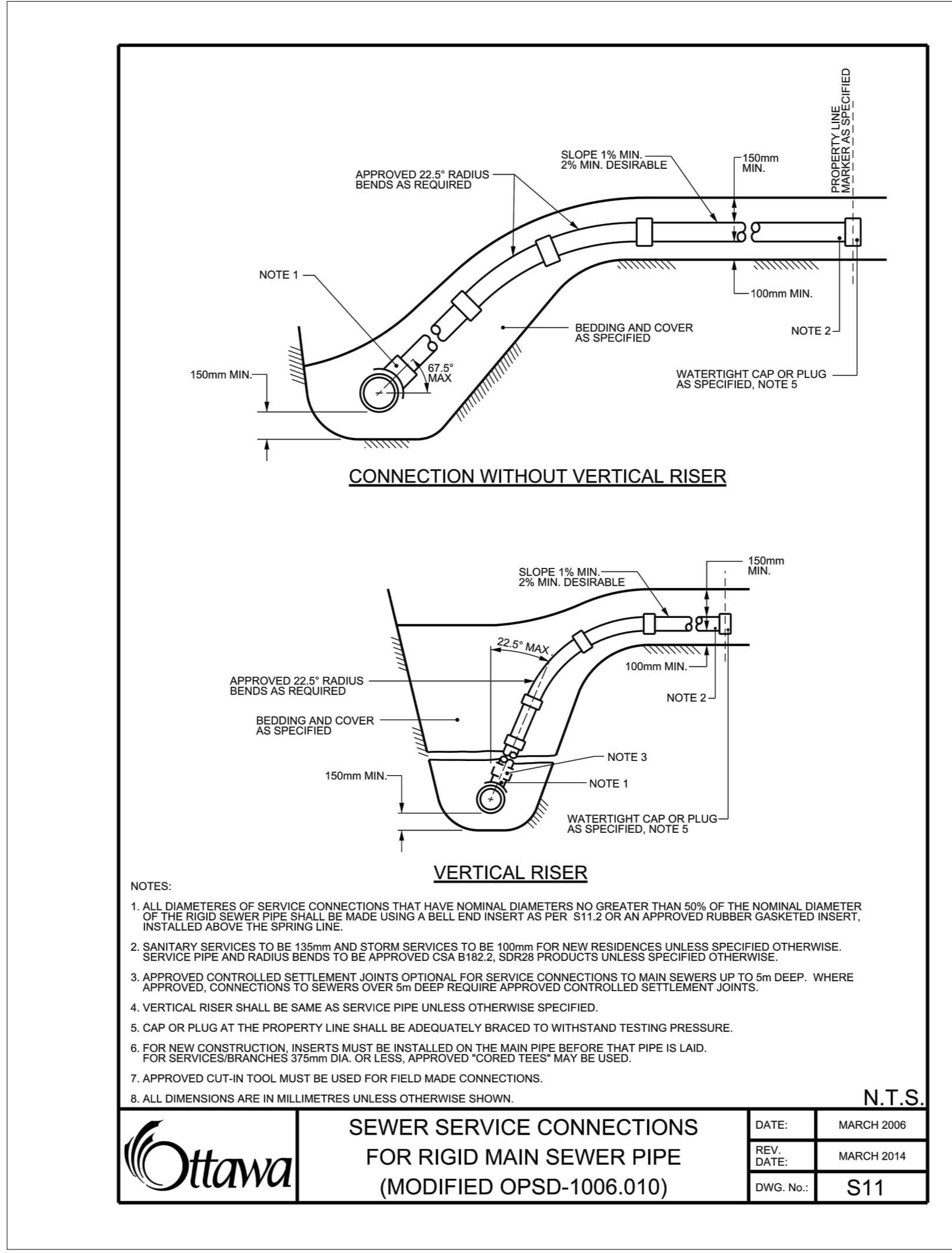
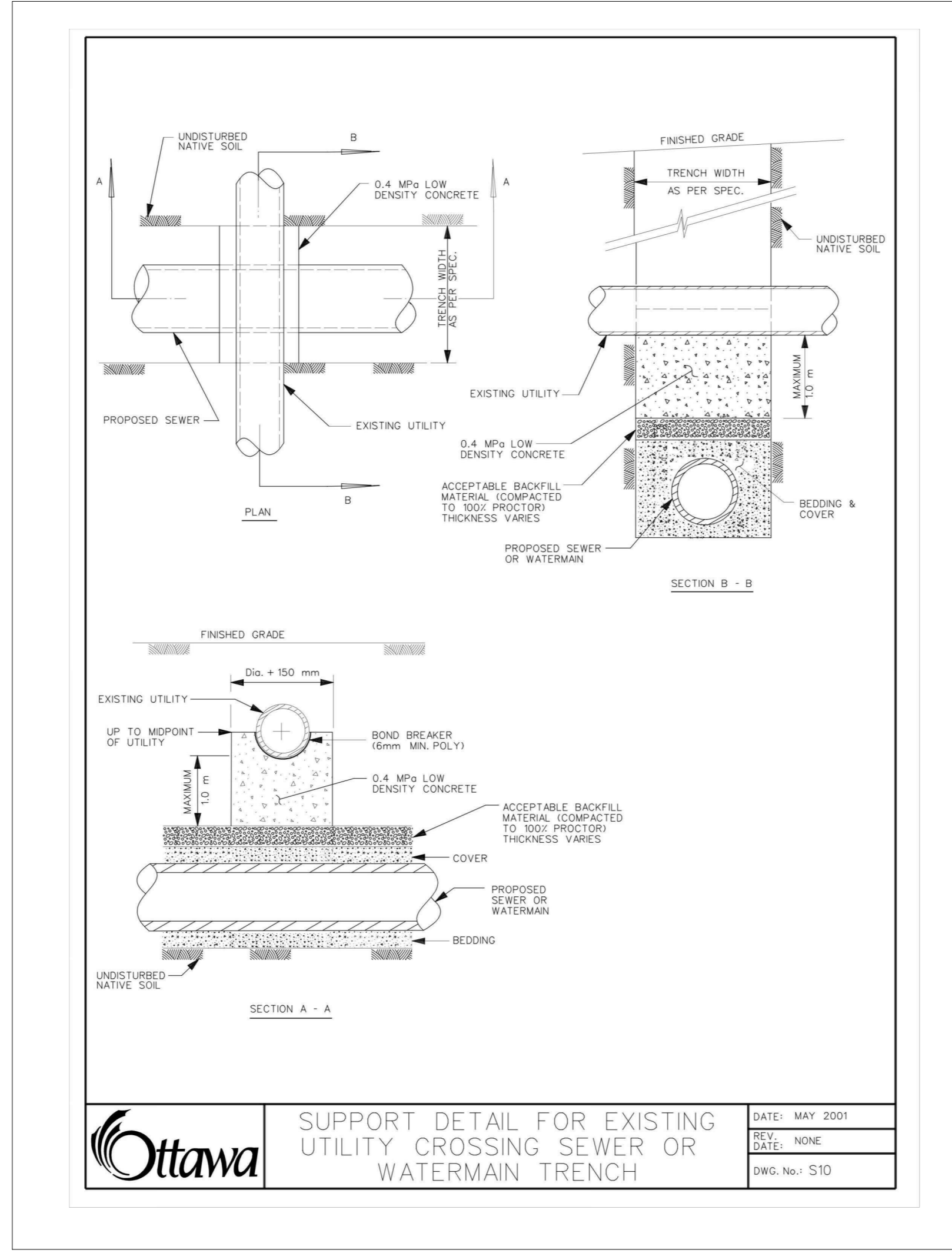
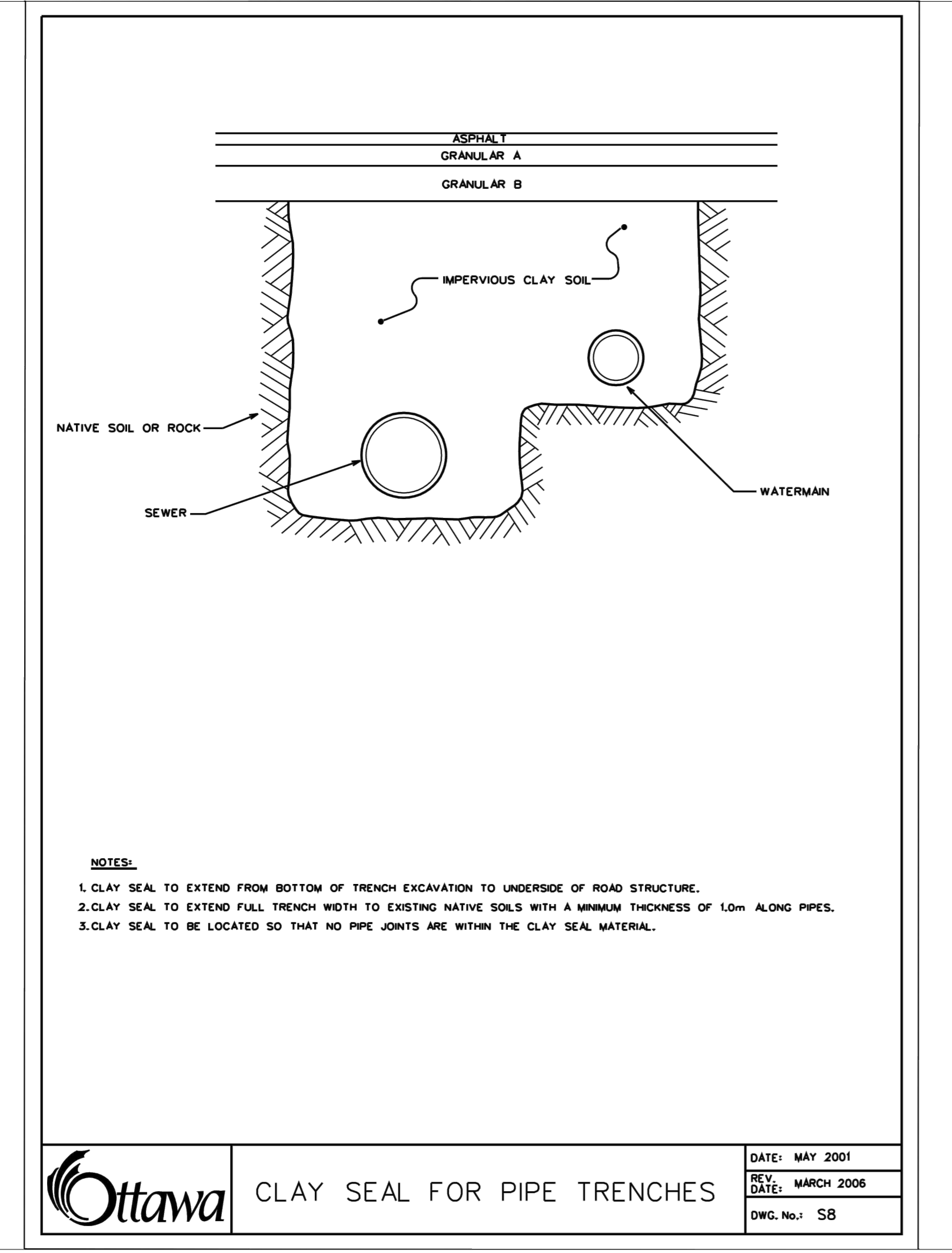

CONTRACTOR MUST CHECK & VERIFY ALL DIMENSIONS ON THE JOB. SHOWN SCALE DRAWING.  
ALL DRAWINGS, SPECIFICATIONS AND RELATED DOCUMENTS ARE THE COPYRIGHT PROPERTY OF THE ARCHITECT AND MUST BE RETURNED UPON REQUEST. REPRODUCTION OF DRAWINGS, SPECIFICATIONS AND RELATED DOCUMENTS IN PART OR IN WHOLE IS FORBIDDEN WITHOUT THE WRITTEN PERMISSION OF THE ARCHITECT.  
THIS DRAWING IS NOT TO BE USED FOR CONSTRUCTION UNLESS SIGNED BY THE ARCHITECT.

OCH FRIEL STREET / CHAPEL  
200201 FRIEL STREET  
221021

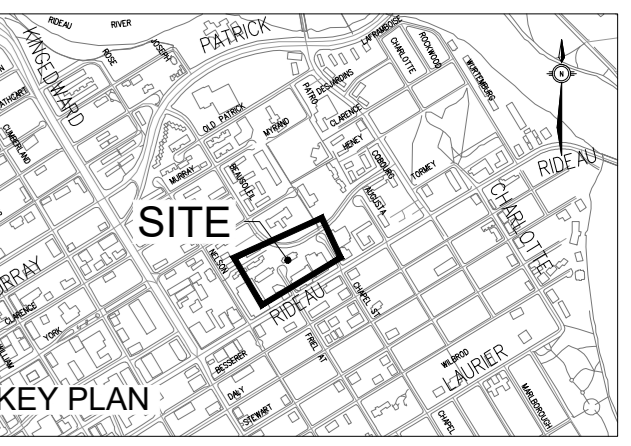

ISSUED

No.	Date	Description
0	2023 MAR 22	ISSUED FOR SITE PLAN APPROVAL
1	2023 MAY 12	ISSUED FOR 100% SCHEMATIC DESIGN
2	2023 MAY 18	ISSUED FOR REZONING AND SITE PLAN CONTROL - RESUBMISSION #1

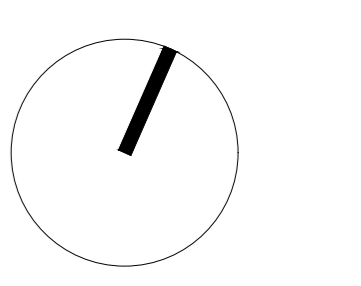
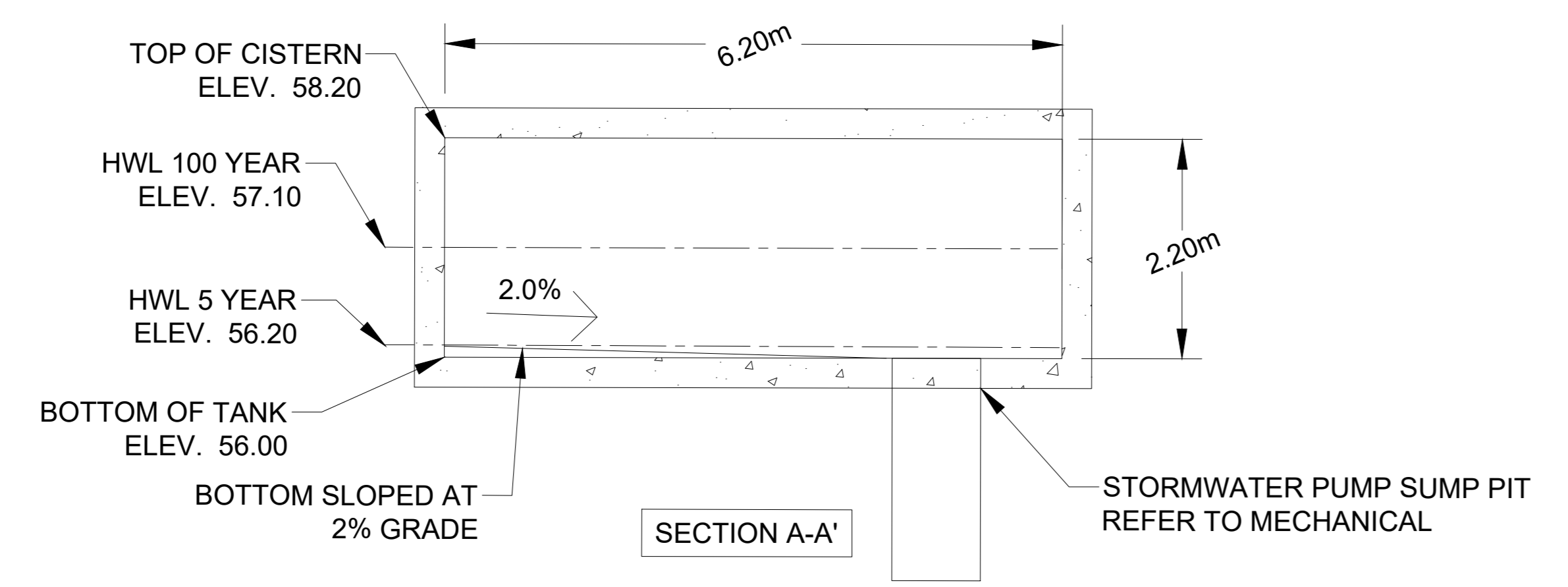
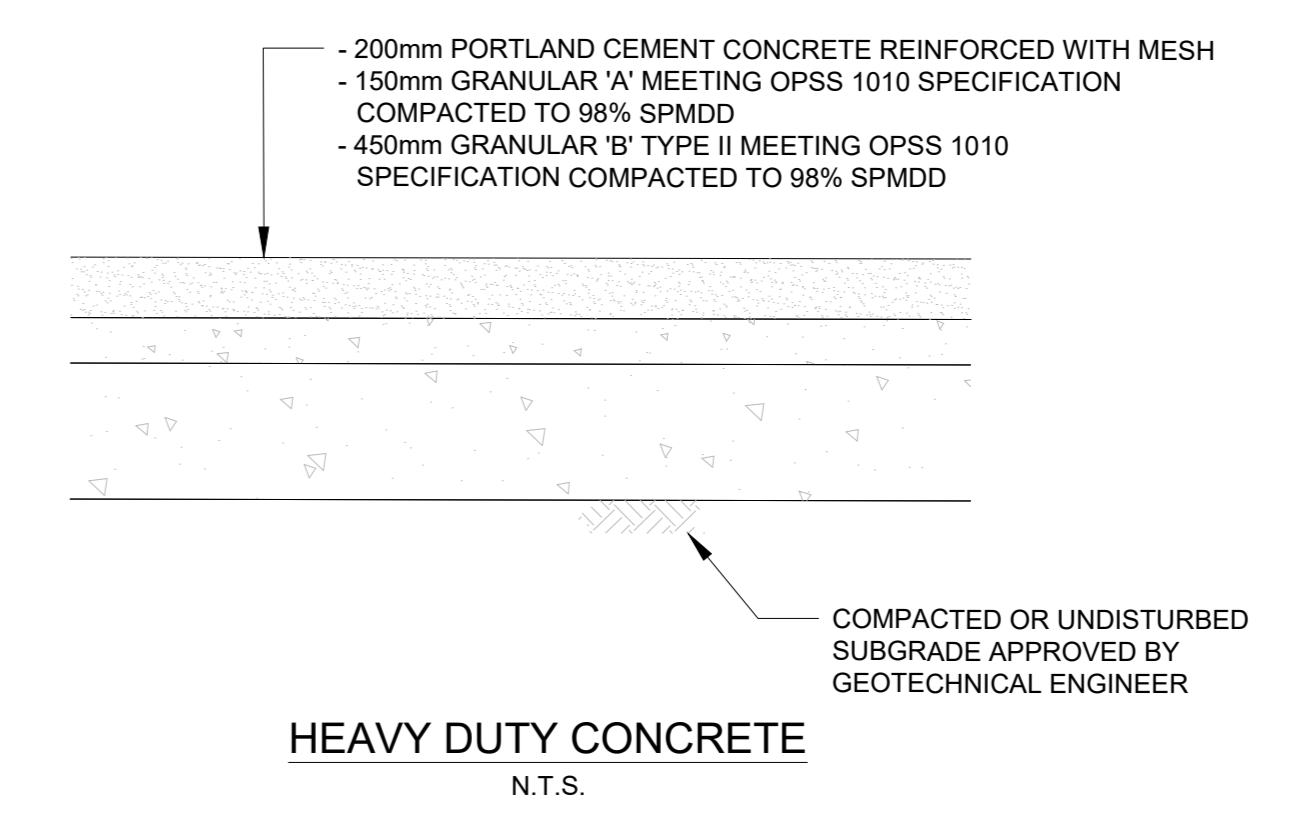
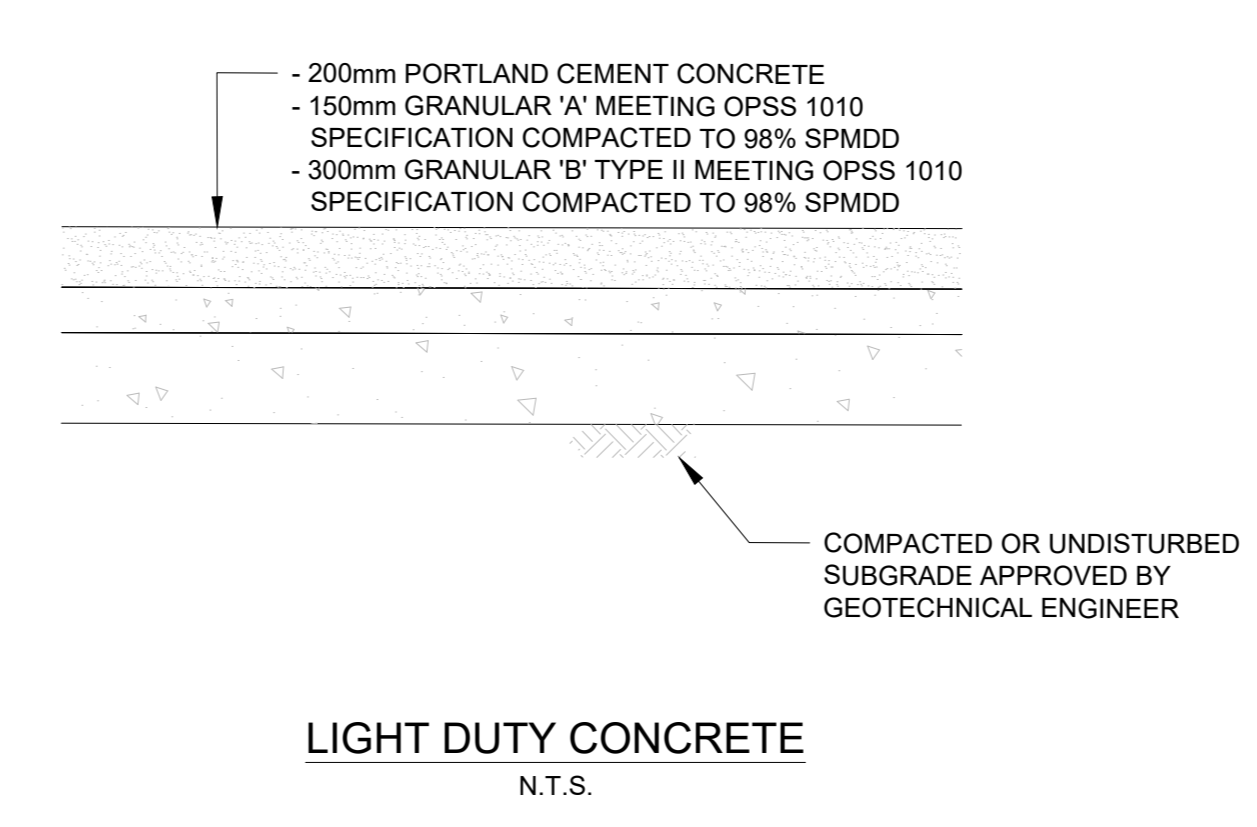
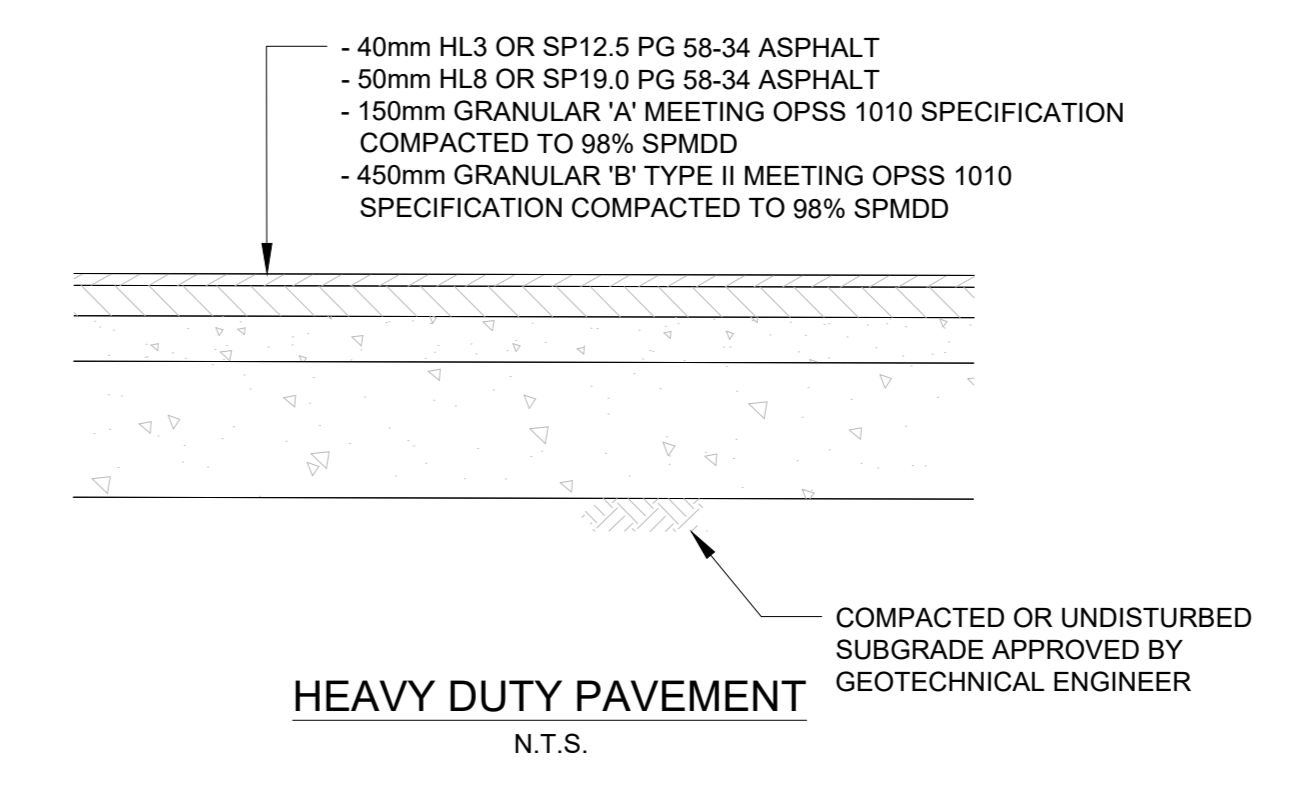
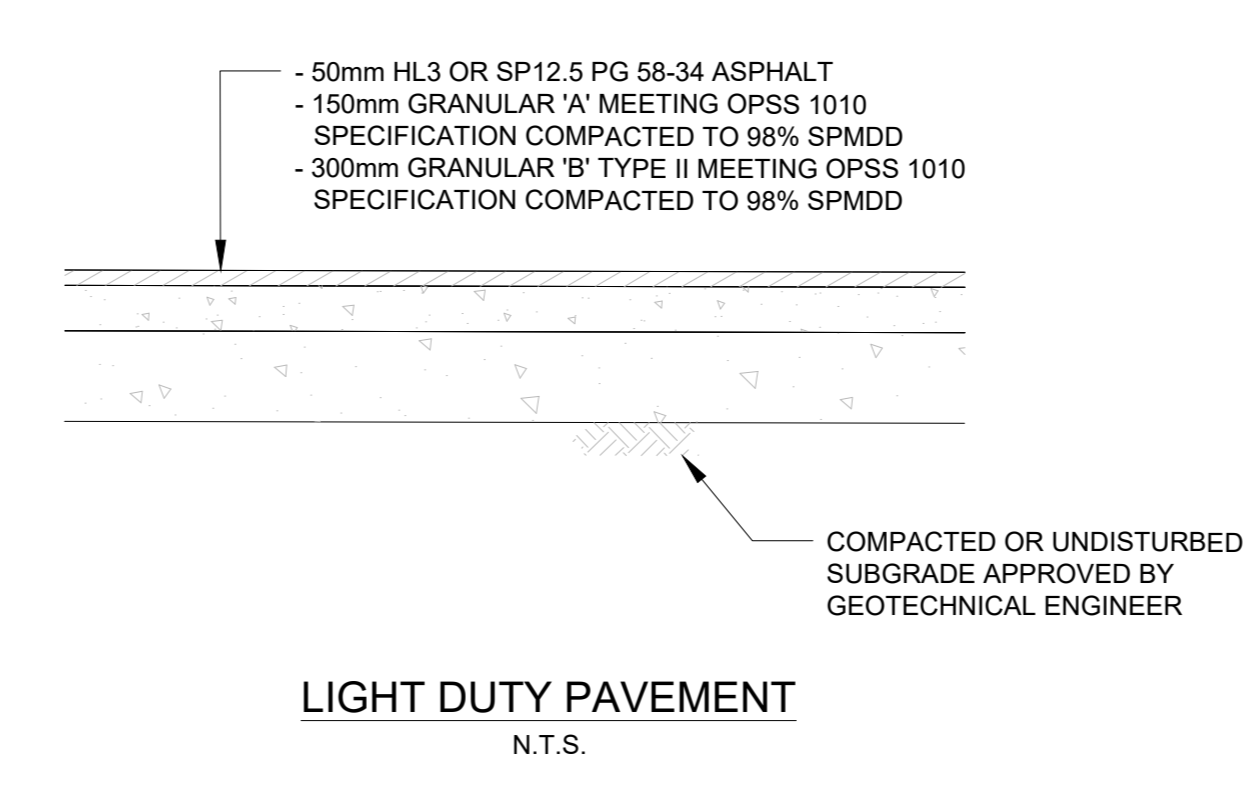
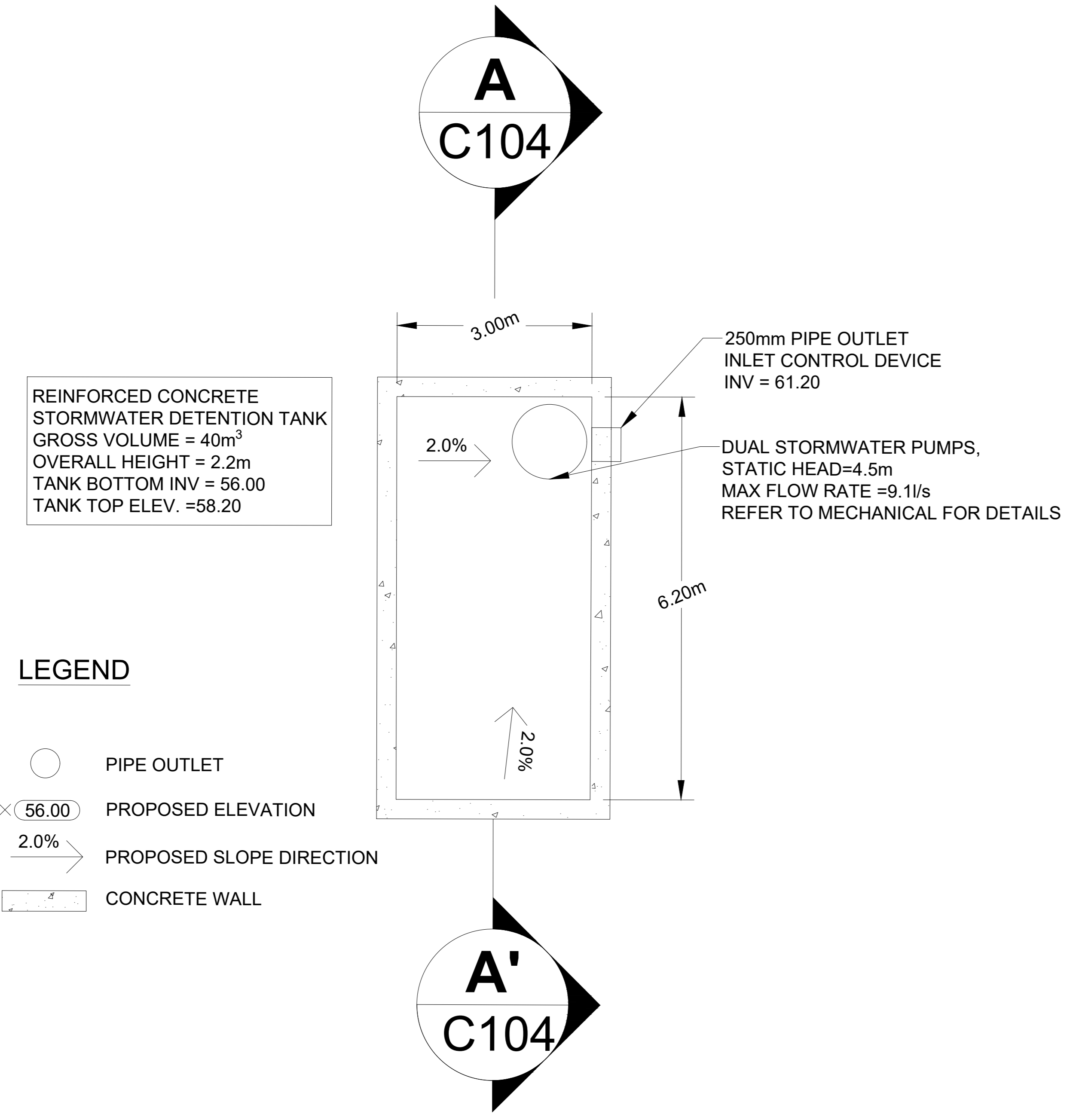

CONTRACTOR MUST CHECK & VERIFY ALL DIMENSIONS ON THE JOB.  
 DO NOT SCALE DRAWINGS.  
 ALL DRAWINGS, SPECIFICATIONS AND RELATED DOCUMENTS ARE THE COPYRIGHT PROPERTY OF THE ARCHITECT AND MUST BE RETURNED UPON REQUEST. REPRODUCTION OF DRAWINGS, SPECIFICATIONS AND RELATED DOCUMENTS IN PART OR IN WHOLE IS FORBIDDEN WITHOUT THE WRITTEN PERMISSION OF THE ARCHITECT.  
 THIS DRAWING IS NOT TO BE USED FOR CONSTRUCTION UNLESS SIGNED BY THE ARCHITECT.

OCH FRIEL STREET / CHAPEL  
 200201 FRIEL STREET  
 221021



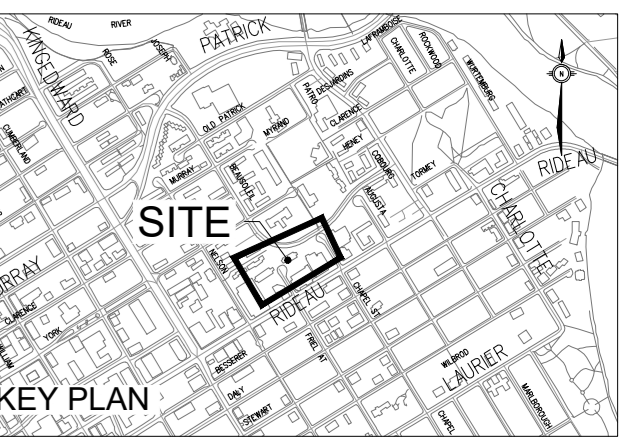

**LEGEND**  
X X X EXISTING WATERMAIN OR SEWER, VALVE CHAMBER, MAINTENANCE HOLE OR CATCH BASIN TO BE REMOVED OR ABANDONED (REMOVE IF WITH EXCAVATION LIMITS).

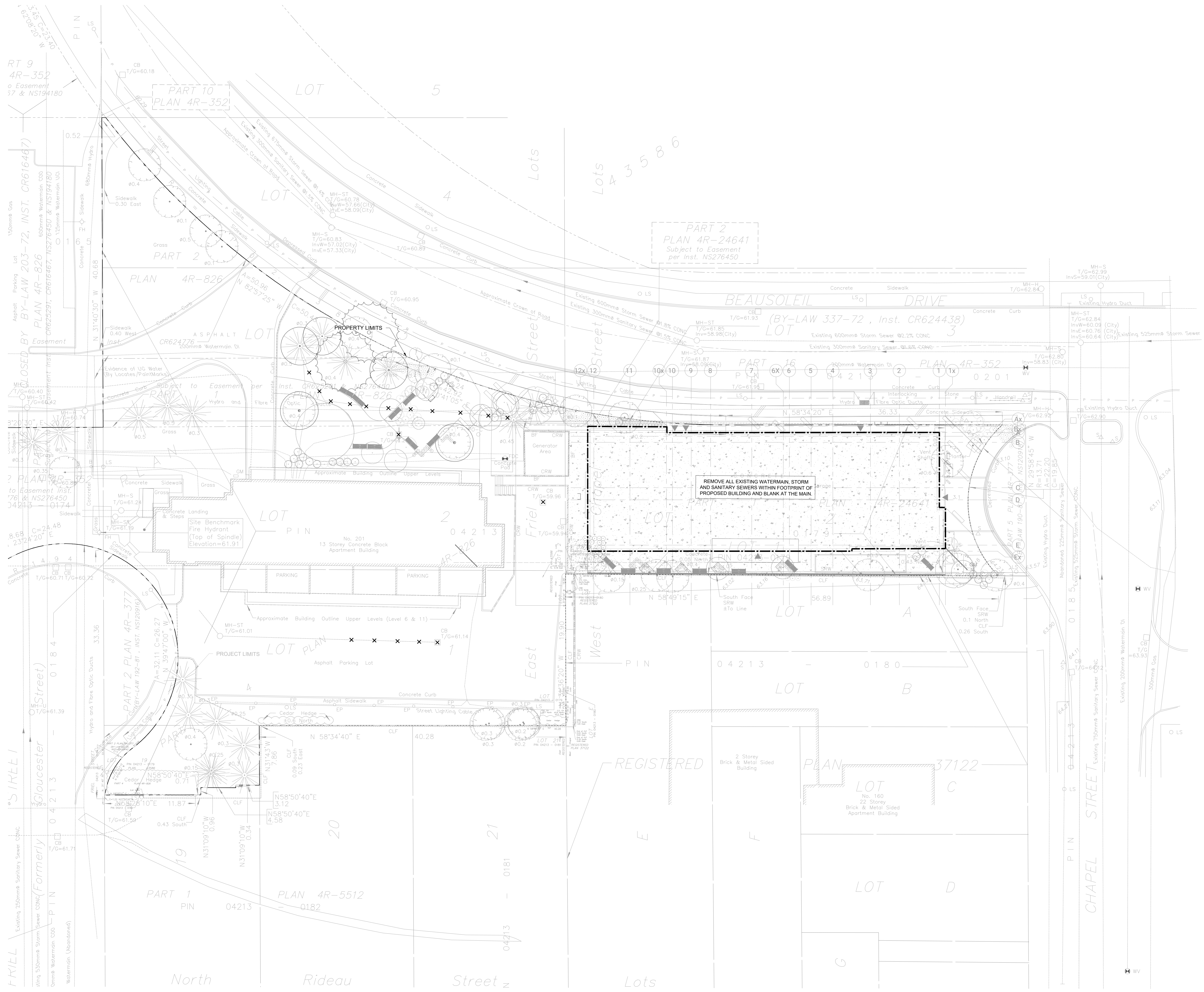

**NOTES:**  
1. COMPLETE ALL REMOVALS AND ABANDONMENTS IN ACCORDANCE WITH GPSS MUNI. 516.

**ISSUED**

No.	Date	Description
0	2023 MAR 22	ISSUED FOR SITE PLAN APPROVAL
1	2023 MAY 12	ISSUED FOR 100% SCHEMATIC DESIGN
2	2023 MAY 18	ISSUED FOR REZONING AND SITE PLAN CONTROL - RESUBMISSION #1

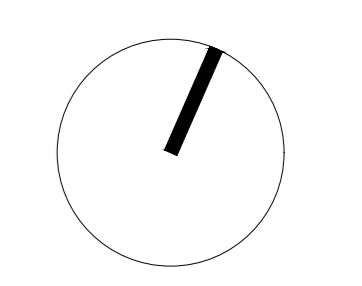
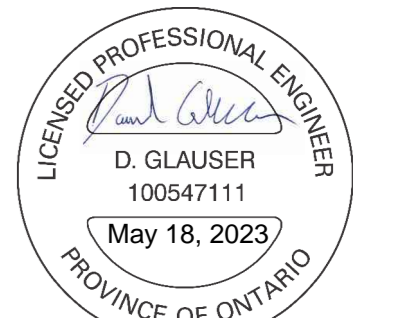

CONTRACTOR MUST CHECK AND VERIFY ALL DIMENSIONS ON THE JOB. 50/40 SCALE DRAWING.  
ALL DRAWINGS, SPECIFICATIONS AND RELATED DOCUMENTS ARE THE COPYRIGHT PROPERTY OF THE ARCHITECT AND MUST BE RETURNED UPON REQUEST. REPRODUCTION OF DRAWINGS, SPECIFICATIONS AND RELATED DOCUMENTS IN PART OR IN WHOLE IS FORBIDDEN WITHOUT THE WRITTEN PERMISSION OF THE ARCHITECT.  
THIS DRAWING IS NOT TO BE USED FOR CONSTRUCTION UNLESS SIGNED BY THE ARCHITECT.

OCH FRIEL STREET / CHAPEL  
200201 FRIEL STREET  
221021

Scale: 1:200  
Project No: 220282000  
Date: 18/05/23

REMOVALS PLAN  
#18930  
C700

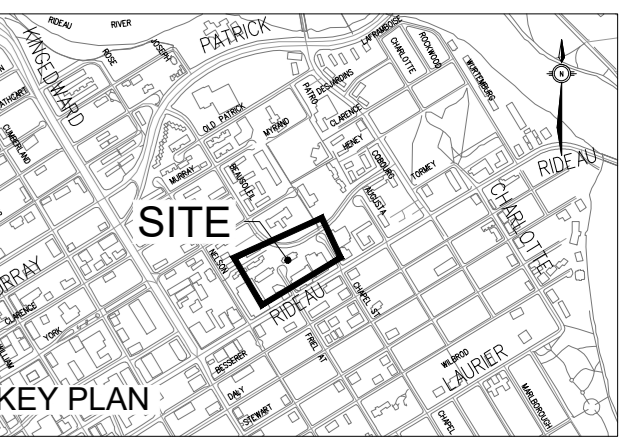

ISSUED

No.	Date	Description
0	2023 MAR 22	ISSUED FOR SITE PLAN APPROVAL
1	2023 MAR 22	ISSUED FOR 100% SCHEMATIC DESIGN
2	2023 MAY 18	ISSUED FOR REZONING AND SITE PLAN CONTROL - RESUBMISSION #1

**LEGEND**

- FLOW CONTROLLED ROOF DRAIN
- UNCONTROLLED FLOW ROOF DRAIN
- AMENITY/UNOCCUPIABLE ROOF - NO FLOW CONTROL
- 5 YR=22mm DEPTH
- 100 YR=60mm DEPTH

**PRODUCT HEAD vs. FLOW**

PONDING DEPTH (m)	FLOW (L/s)				
	OPEN	3/4	1/2	1/4	CLOSED
0.025	0.315	0.315	0.315	0.315	0.315
0.05	0.631	0.631	0.631	0.631	0.315
0.075	0.946	0.867	0.789	0.710	0.315
0.1	1.262	1.104	0.946	0.789	0.315
0.125	1.577	1.341	1.104	0.867	0.315
0.15	1.893	1.577	1.262	0.946	0.315

- NOTES:
- PRODUCT - ADJUSTABLE ACCUTROL WEIR SETTING - 3/4 FLOW RATE APPROX. 0.8L/s IN 100-YR EVENT
  - FOR SCUPPER / EMERGENCY OVERFLOW LOCATIONS / ELEVATION REFER TO ARCHITECTURAL

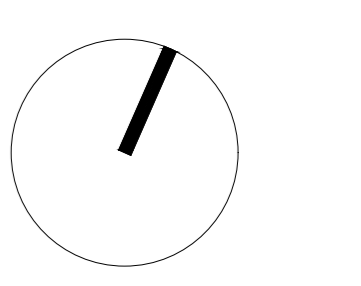
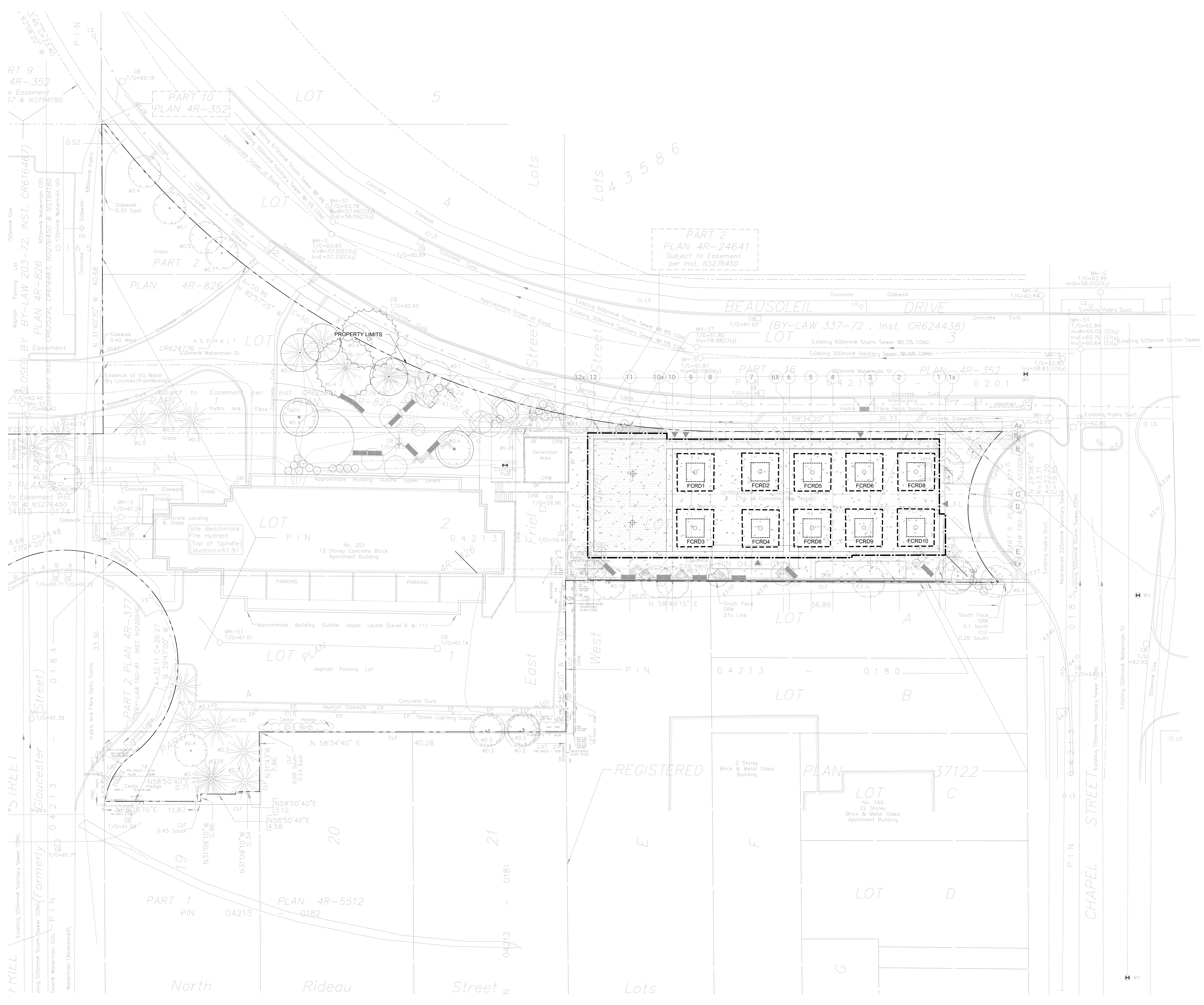

CONTRACTOR MUST CHECK & VERIFY ALL DIMENSIONS ON THE JOB. 50:40 SCALE DRAWING.  
ALL DRAWINGS, SPECIFICATIONS AND RELATED DOCUMENTS ARE THE COPYRIGHT PROPERTY OF THE ARCHITECT AND MUST BE RETURNED UPON REQUEST. REPRODUCTION OF DRAWINGS, SPECIFICATIONS AND RELATED DOCUMENTS IN PART OR IN WHOLE IS FORBIDDEN WITHOUT THE WRITTEN PERMISSION OF THE ARCHITECT.  
THIS DRAWING IS NOT TO BE USED FOR CONSTRUCTION UNLESS SIGNED BY THE ARCHITECT.

OCH FRIEL STREET / CHAPEL  
200201 FRIEL STREET  
221021

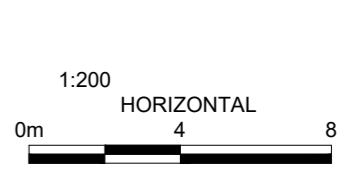

ROOF DRAIN LAYOUT & PONDING  
Scale: 1:200  
Project No: 220282000  
Date: 18/05/23

**C701**  
#18930

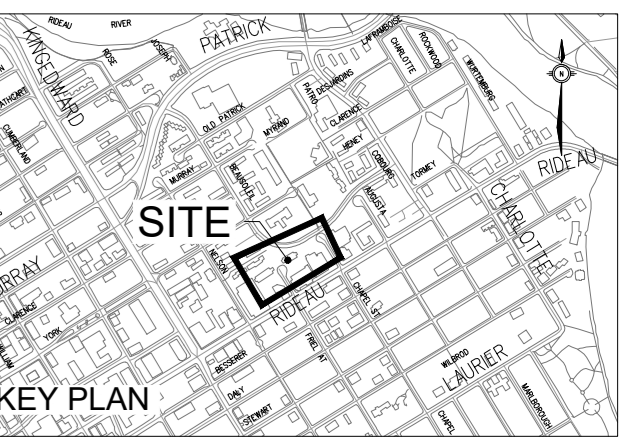

ISSUED

No.	Date	Description
0	2023 MAR 22	ISSUED FOR SITE PLAN APPROVAL
1	2023 MAY 12	ISSUED FOR 100% SCHEMATIC DESIGN
2	2023 MAY 18	ISSUED FOR ZONING AND SITE PLAN CONTROL - RESUBMISSION #1

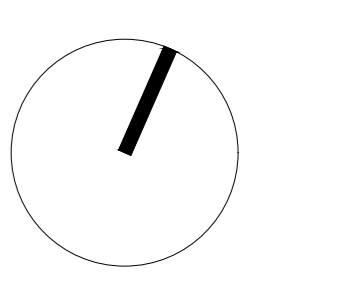
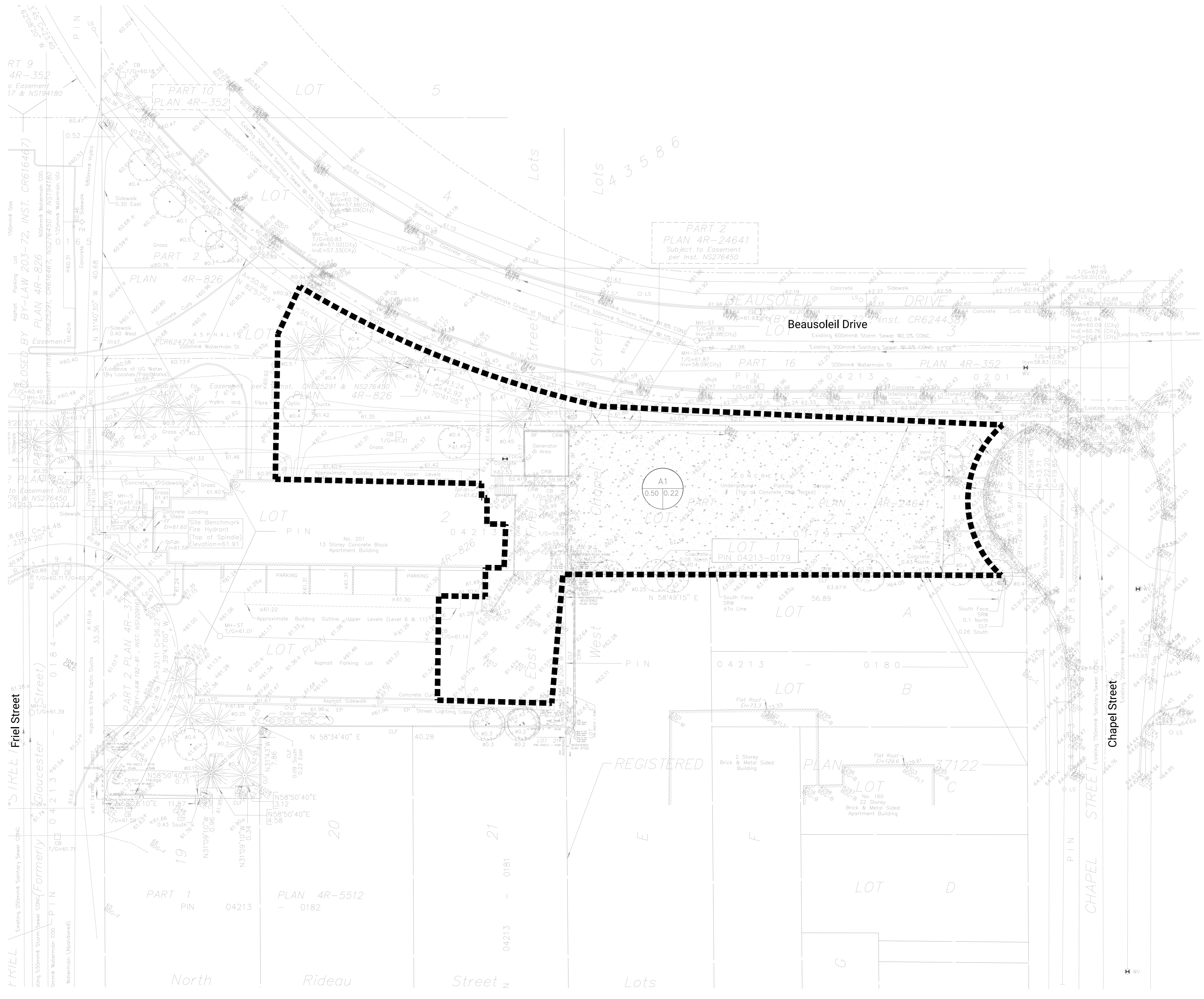
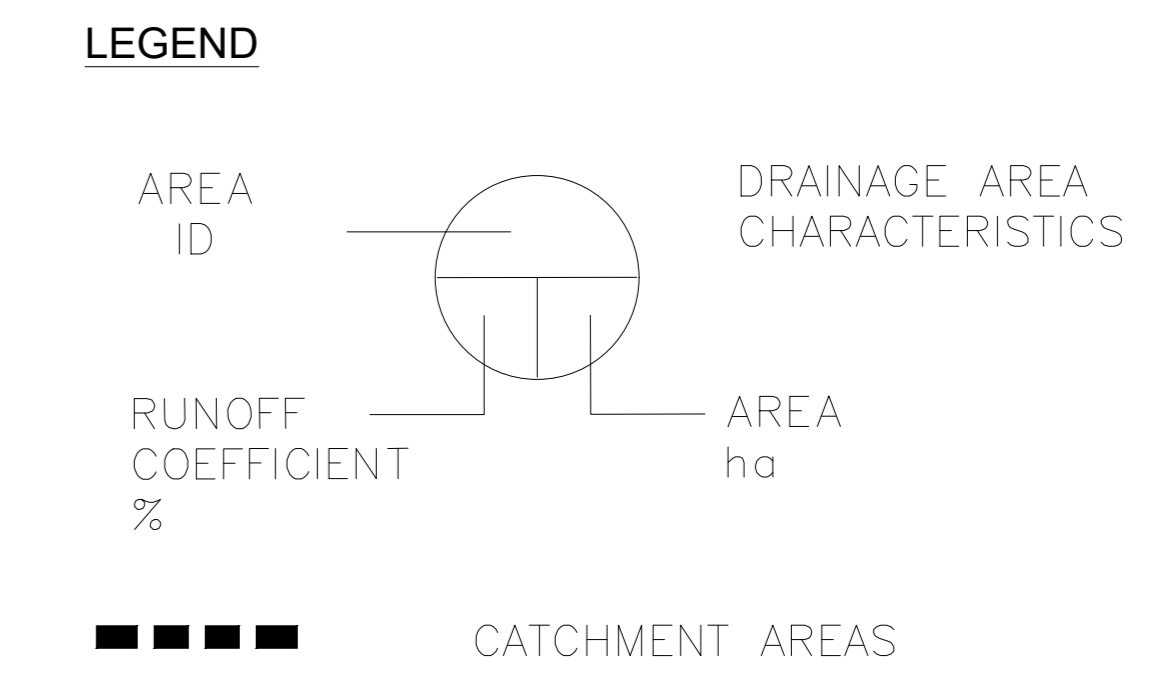

CONTRACTOR MUST CHECK & VERIFY ALL DIMENSIONS ON THE JOB. SEE 40% SCALE DRAWINGS.  
ALL DRAWINGS, SPECIFICATIONS AND RELATED DOCUMENTS ARE THE COPYRIGHT PROPERTY OF THE ARCHITECT AND MUST BE RETURNED UPON REQUEST. REPRODUCTION OF DRAWINGS, SPECIFICATIONS AND RELATED DOCUMENTS IN PART OR IN WHOLE IS FORBIDDEN WITHOUT THE WRITTEN PERMISSION OF THE ARCHITECT.  
THIS DRAWING IS NOT TO BE USED FOR CONSTRUCTION UNLESS SIGNED BY THE ARCHITECT.

OCH FRIEL STREET / CHAPEL  
200001 FRIEL STREET  
221021

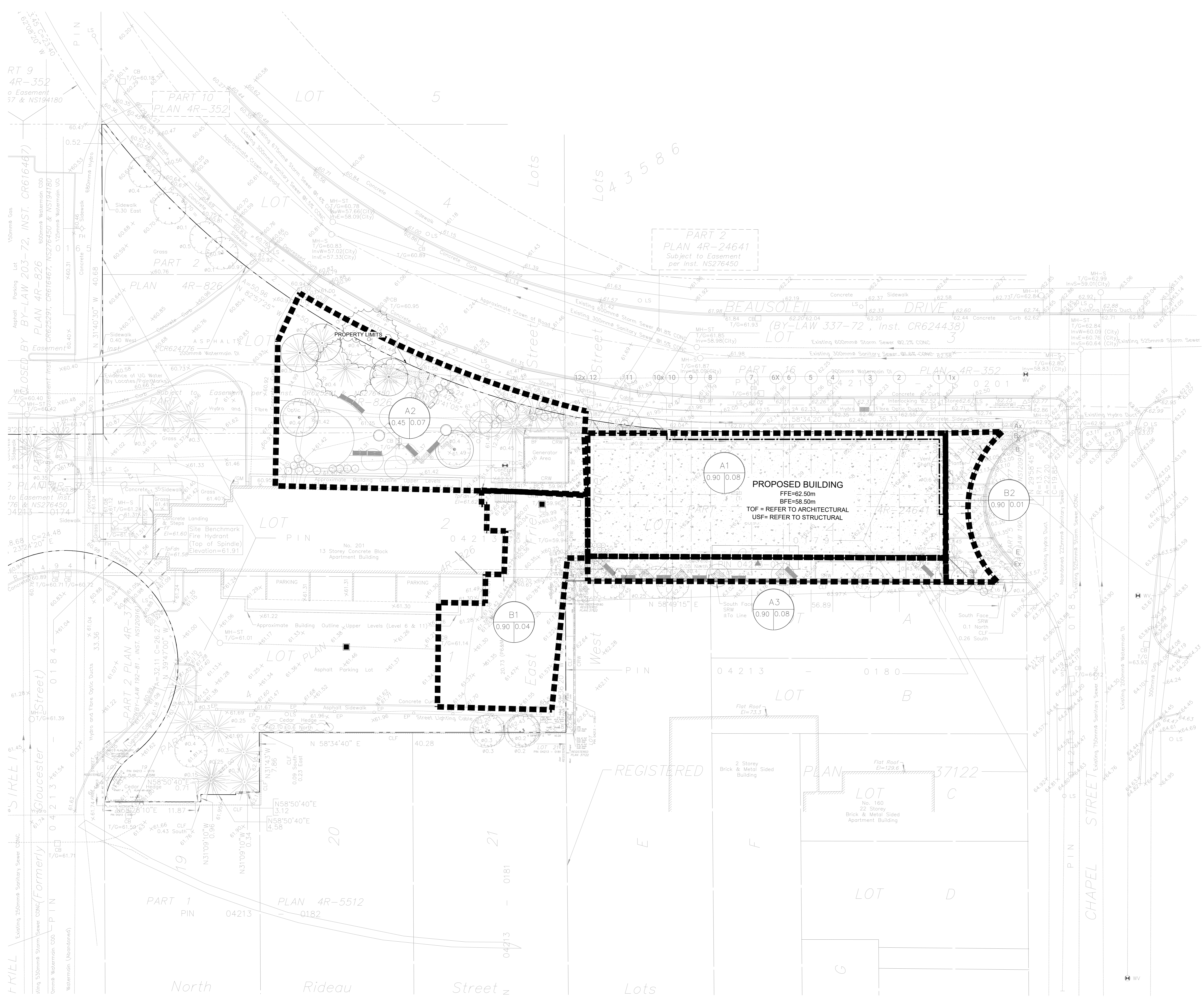

NOTES  
 1. A1, A2 & A3 ARE PROPOSED CONTROLLED CATCHMENTS.  
 B1 & B2 ARE PROPOSED UNCONTROLLED CATCHMENTS.

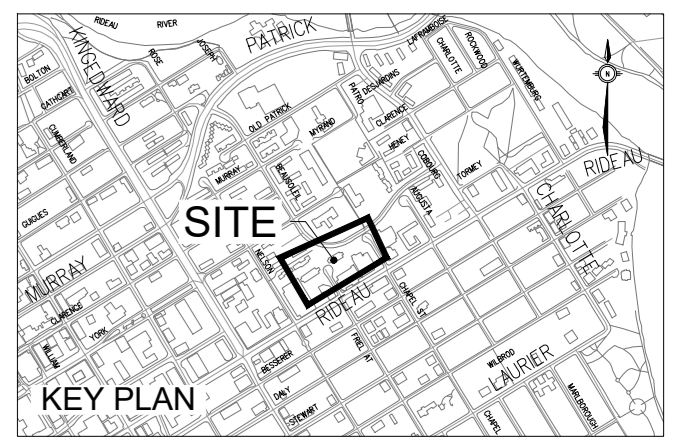
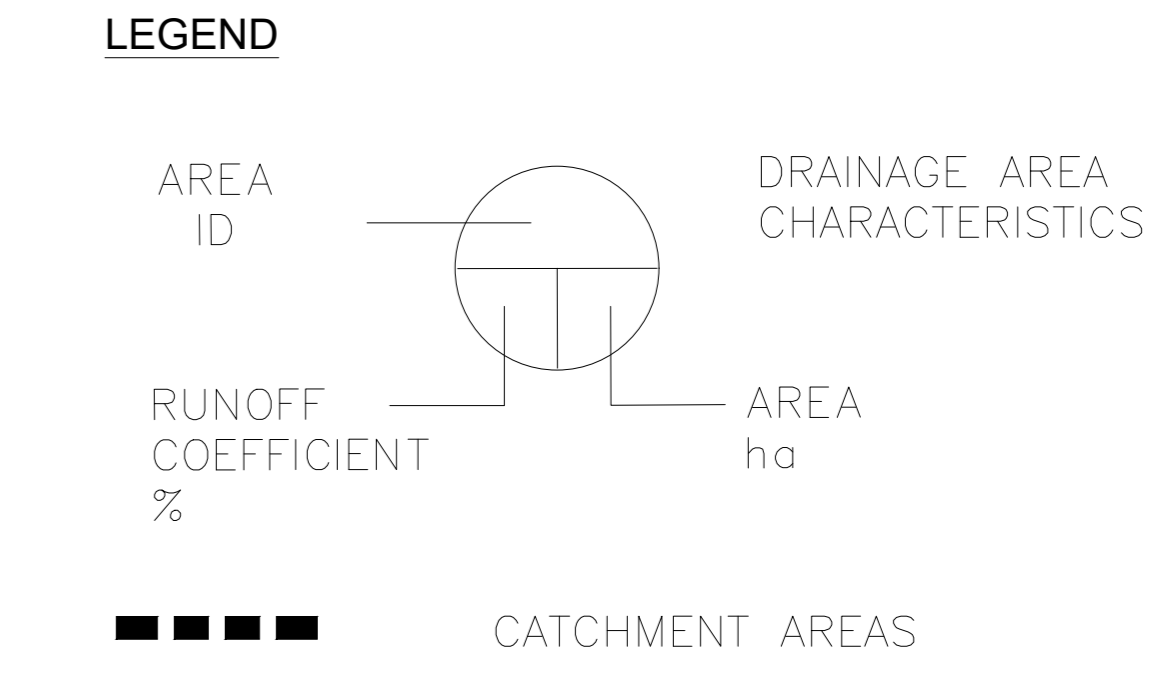

ISSUED

No.	Date	Description
0	2023 MAR 22	ISSUED FOR SITE PLAN APPROVAL
1	2023 MAY 12	ISSUED FOR 100% SCHEMATIC DESIGN
2	2023 MAY 18	ISSUED FOR REZONING AND SITE PLAN CONTROL - RESUBMISSION #1

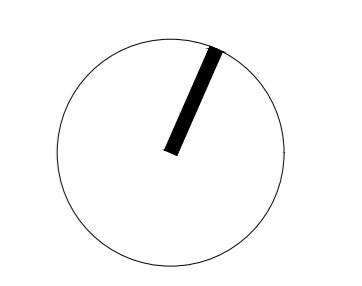

CONTRACTOR MUST CHECK & VERIFY ALL DIMENSIONS ON THE JOB. SEE 40% SCALE DRAWINGS.  
 ALL DRAWINGS, SPECIFICATIONS AND RELATED DOCUMENTS ARE THE COPYRIGHT PROPERTY OF THE ARCHITECT AND MUST BE RETURNED UPON REQUEST. REPRODUCTION OF DRAWINGS, SPECIFICATIONS AND RELATED DOCUMENTS IN PART OR IN WHOLE IS FORBIDDEN WITHOUT THE WRITTEN PERMISSION OF THE ARCHITECT.  
 THIS DRAWING IS NOT TO BE USED FOR CONSTRUCTION UNLESS SIGNED BY THE ARCHITECT.

OCH FRIEL STREET / CHAPEL  
 200001 FRIEL STREET  
 221021