



**ADEQUACY OF PUBLIC SERVICES  
REPORT - JULIAN OF NORWICH (8  
WITHROW AVENUE AND 7 ROSSLAND  
AVENUE)**

November 20, 2023

Prepared for:  
Figurr Architects Collective  
on behalf of  
The Anglican Diocese of Ottawa

Prepared by:  
Stantec Consulting Ltd.

Stantec Project Number:  
160401691

City of Ottawa File Number:  
D02-02-23-0062

**Adequacy of Public Services Report - Julian of Norwich (8 Withrow Avenue and 7 Rossland Avenue)**

**Introduction**

<b>Revision</b>	<b>Description</b>	<b>Author</b>	<b>Date</b>	<b>Quality Check</b>	<b>Date</b>	<b>Independent Review</b>	<b>Date</b>
0	ZBLA 1 <sup>st</sup> Submission	MW PM	2023/07/07 2023/07/07	RB	2023/07/07	AG/NC	2023/07/07
1	ZBLA 2nd Submission	MW	2023/11/20	RB	2023/11/20	AG/DT	2023/11/20



# Adequacy of Public Services Report - Julian of Norwich (8 Withrow Avenue and 7 Rossland Avenue)

## Introduction

The conclusions in the Report titled **Adequacy of Public Services Report – Julian of Norwich (8 Withrow Avenue and 7 Rossland Avenue)** are Stantec's professional opinion, as of the time of the Report, and concerning the scope described in the Report. The opinions in the document are based on conditions and information existing at the time the scope of work was conducted and do not take into account any subsequent changes. The Report relates solely to the specific project for which Stantec was retained and the stated purpose for which the Report was prepared. The Report is not to be used or relied on for any variation or extension of the project, or for any other project or purpose, and any unauthorized use or reliance is at the recipient's own risk.

Stantec has assumed all information received from Figurr Architects Collective and the Anglican Diocese of Ottawa (the "Client") and third parties in the preparation of the Report to be correct. While Stantec has exercised a customary level of judgment or due diligence in the use of such information, Stantec assumes no responsibility for the consequences of any error or omission contained therein.

This Report is intended solely for use by the Client in accordance with Stantec's contract with the Client. While the Report may be provided by the Client to applicable authorities having jurisdiction and to other third parties in connection with the project, Stantec disclaims any legal duty based upon warranty, reliance or any other theory to any third party, and will not be liable to such third party for any damages or losses of any kind that may result.

Prepared by:  Digitally signed by Wu, Michael  
Date: 2023.11.20 16:14:08 -05'00'

---

Signature

Michael Wu, EIT

---

Printed Name

Reviewed by:  Digitally signed by Gladish, Alyssa  
Date: 2023.11.20 16:34:12 -05'00'

---

Signature

Alyssa Gladish, EIT

---

Printed Name

Approved by: 

---

Signature

Robert Brandrick, P.Eng

---

Printed Name



## Table of Contents

<b>1.0</b>	<b>INTRODUCTION.....</b>	<b>1</b>
1.1	Objective.....	2
<b>2.0</b>	<b>BACKGROUND.....</b>	<b>4</b>
<b>3.0</b>	<b>POTABLE WATER SERVICING .....</b>	<b>5</b>
3.1	Background .....	5
3.2	Water Demands.....	5
3.2.1	Potable (Domestic) Water Demands.....	5
3.2.2	Fire Flow Demands .....	6
3.3	Level of Servicing .....	6
3.3.1	Boundary Conditions .....	6
3.3.2	Allowable Domestic Pressures.....	7
3.3.3	Allowable Fire Flow Pressures .....	7
3.3.4	Fire Hydrant Coverage .....	7
3.4	Proposed Water Servicing.....	9
<b>4.0</b>	<b>WASTEWATER SERVICING.....</b>	<b>10</b>
4.1	Background .....	10
4.2	Design Criteria .....	10
4.3	Wastewater Generation and Servicing Design .....	10
4.4	Proposed Sanitary Servicing .....	11
<b>5.0</b>	<b>STORMWATER MANAGEMENT AND SERVICING .....</b>	<b>12</b>
5.1	Background .....	12
5.2	Stormwater Management (SWM) Criteria .....	12
5.3	Existing Conditions.....	13
5.4	Stormwater Management Design.....	13
5.4.1	Allowable Release Rate .....	14
5.4.2	Quantity Control.....	15
5.4.3	Quality Control.....	16
5.5	Results.....	16
5.6	Proposed Stormwater Servicing.....	16
<b>6.0</b>	<b>SITE GRADING .....</b>	<b>18</b>
<b>7.0</b>	<b>UTILITIES.....</b>	<b>19</b>
<b>8.0</b>	<b>APPROVALS.....</b>	<b>20</b>
<b>9.0</b>	<b>EROSION AND SEDIMENT CONTROL DURING CONSTRUCTION.....</b>	<b>21</b>
<b>10.0</b>	<b>GEOTECHNICAL INVESTIGATION .....</b>	<b>22</b>
<b>11.0</b>	<b>CONCLUSIONS.....</b>	<b>23</b>
11.1	Potable Water Servicing .....	23
11.2	Sanitary Servicing.....	23
11.3	Stormwater Servicing and Management .....	23
11.4	Grading .....	23
11.5	Erosion and Sediment Control During Construction .....	24
11.6	Geotechnical Investigation .....	24
11.7	Utilities .....	24
11.8	Approvals.....	24



**Adequacy of Public Services Report - Julian of Norwich (8 Withrow Avenue and 7 Rossland Avenue)**

**Introduction**

List of Tables

Table 3.1: Estimated Domestic Water Demands .....	6
Table 3.2: Boundary Conditions.....	7
Table 3.3: Fire Hydrant Coverage Table.....	8
Table 4.1: Estimated Peak Wastewater Flow .....	10
Table 5.1: Summary of Post-Development Drainage Areas .....	14
Table 5.2: Allowable Target Release Rate .....	15
Table 5.3: Peak Post-Development Discharge of Uncontrolled Areas (UNC-1, UNC-2).....	15
Table 5.4: Comparison of Pre- and Post-Development Release Rates .....	16
Table 10.1: Recommended Pavement Structure.....	22

**LIST OF FIGURES**

Figure 1-1: Key Plan of Site .....	1
Figure 3-1: Fire Hydrant Coverage Sketch .....	8

**LIST OF APPENDICES**

**APPENDIX A BACKGROUND DOCUMENTS .....1**

A.1 Site Plan .....	1
A.2 Topographic Survey .....	2
A.3 Pre-Consultation Meeting Minutes .....	3

**APPENDIX B WATER SERVICING .....4**

B.1 Domestic Water Demands .....	4
B.2 Fire Flow Demands (2020 FUS).....	5
B.3 Boundary Conditions (City of Ottawa).....	6
B.4 Fire Hydrant Coverage Calculations .....	7
B.5 Multi-Hydrant Hydraulic Analysis Request .....	8

**APPENDIX C SANITARY.....1**

C.1 Sanitary Sewer Design Sheet .....	1
C.2 Correspondence with the City on Sanitary Sewer Capacity.....	2

**APPENDIX D STORMWATER SERVICING.....1**

D.1 Modified Rational Method Sheet .....	1
D.2 Storm Sewer Design Sheet .....	2
D.3 Correspondence with the City of Ottawa (SWM Quality Control).....	3
D.4 Preliminary Stormceptor Sizing (SWM Quality Control).....	4



## 1.0 Introduction

Stantec Consulting Ltd. is commissioned by Figurr Architects Collective (Figurr) on behalf of the Anglican Diocese of Ottawa to prepare the following Adequacy of Public Services Report in support of a Zoning By-law Amendment (ZBLA) Application for the proposed development located at 8 Withrow Avenue and 7 Rossland Avenue in the City of Ottawa.

The 0.72 ha site is located in the City View neighbourhood of the City of Ottawa. The site is currently zoned AM10, I1B, and I1B [422] and contains an existing church with two-storey attached and detached accessory buildings, and surface parking. The site is bounded by Rossland Avenue to the north, Withrow Avenue to the south, Merivale Road to the east, and existing residential developments to the west, as shown in **Figure 1-1** below.

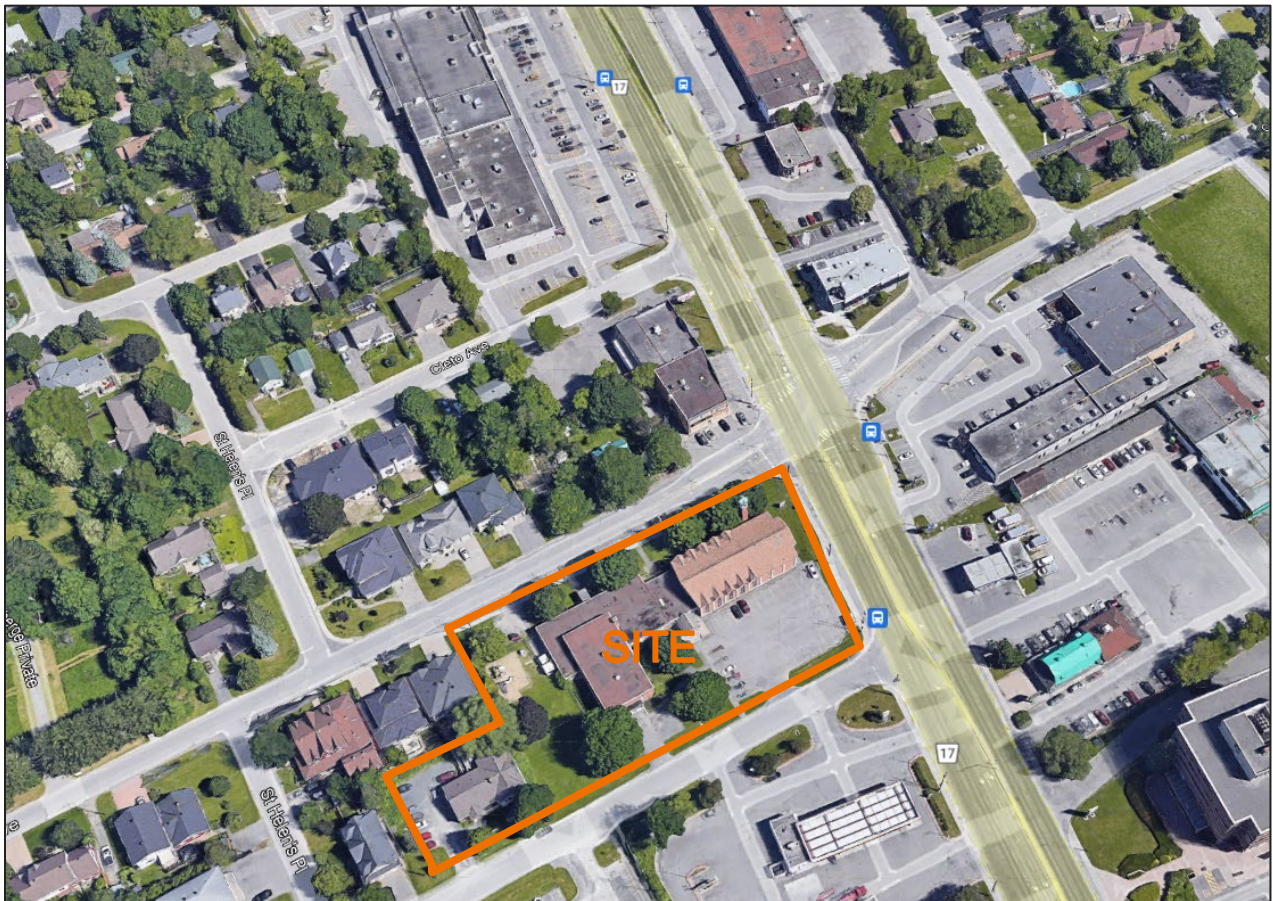

**Figure 1-1: Key Plan of Site**

The proposed development is an eight-storey apartment building integrated with a church and two sets of three-storey stacked and back-to-back townhouses. Overall, the development provides 84 residential units and 373 m<sup>2</sup> for the church and associated common spaces. The eight-storey apartment building



# Adequacy of Public Services Report - Julian of Norwich (8 Withrow Avenue and 7 Rossland Avenue)

## Introduction

provides 57 units; one studio unit, 22 one-bedroom units, 20 two-bedroom units, and 14 three-bedroom units. In addition, the ground floor of the eight-storey apartment building provides institutional uses such as office space, meeting rooms and common amenity areas to be used by the church and the residential building. The three-storey stacked and back-to-back townhouses provide 27 units; one 15-unit building fronting Rossland Avenue and one 12-unit building fronting Withrow Avenue. A small community shed/pavilion is also provided for shared use. The draft Site Plan prepared by Figurr Architects Collective is provided in **Appendix A.1**.

## 1.1 Objective

This Adequacy of Public Services Report presents a preliminary servicing scheme and preliminary stormwater management (SWM) concept that is free of conflicts, provides onsite servicing concept in accordance with City of Ottawa Design Guidelines, and uses the existing municipal infrastructure in compliance with any limitations communicated during consultation with the City of Ottawa staff. Details of the existing infrastructure located within the Merivale Road, Rossland Avenue, and Withrow Avenue right of way (ROW) are obtained from available as-built drawings and site topographic survey.

Criteria and constraints provided by the City of Ottawa are used as a basis for the preliminary servicing design supporting the proposed development. General and site-specific conditions considered are as follows:

- **Potable Water Servicing**
  - Estimated water demands to characterize the proposed feed(s) for the proposed development serviced from the existing 200 mm diameter watermain within the Rossland Avenue ROW.
  - Watermain servicing for the development is to provide average day and maximum day (including peak hour) demands (i.e., non-emergency conditions) at pressures within the acceptable range of 345 to 552 kPa (50 to 80 psi).
  - Under fire flow (emergency) conditions, the water distribution system is to maintain a minimum pressure greater than 140 kPa (20 psi).
  - Potable water servicing requires two connections separated by an isolation valve to avoid the creation of a vulnerable service area. Looped watermain is not feasible on this site due to different Water Pressure Zones on Withrow and Rossland (two connections must be within the same zone).
- **Wastewater (Sanitary) Servicing**
  - Identify the wastewater design flow from the proposed development.
  - Define and provide preliminary size of the proposed sanitary sewers within the site that will be connected to the existing 200 mm diameter sanitary sewer within the Rossland Avenue ROW.
- **Storm Sewer Servicing**
  - Define functional major and minor system conveyance patterns and drainage boundaries in conjunction with the proposed grading plan.
  - Determine the preliminary stormwater management storage requirements for water quantity control to meet the allowable release rates for the site.



## Adequacy of Public Services Report - Julian of Norwich (8 Withrow Avenue and 7 Rossland Avenue)

### Introduction

- Identify the intended water quality control measures to be applied to the site.
- Define and provide preliminary size of the proposed storm sewers within the site.
- Define and provide preliminary size of the proposed storm sewer extension within the Rossland Avenue ROW that will connect the site to the existing 300 mm diameter sewer stub and immediately downstream 525 mm diameter storm sewer within the Merivale Road ROW.
- Existing culverts to be removed and identify the location of new culverts proposed to maintain the existing ditch drainage along the north side of the Withrow Avenue ROW.
- **Site Grading Plan**
  - Prepare a preliminary grading plan in accordance with the proposed site plan and existing grades.
- **Tree Conservation Considerations**
  - The functional servicing schemes, stormwater management concept, and preliminary site grading shall be aligned with the Site Plan and Tree Conservation Report (TCR) to minimize the impacts to the existing high-value trees onsite that are to be preserved.
  - The critical root zones (CRZs) of the trees to be retained have been extracted from the TCR and incorporated into the civil servicing drawings to demonstrate the minimal impacts to the trees' CRZs.
  - The Landscape Architecture team will further review the impact of the infrastructure on the retained trees at detailed design and servicing alignments will be adjusted as required to accommodate tree retention at that time.

The accompanying drawings illustrate the preliminary internal servicing scheme for the site at a functional level to demonstrate the feasibility of servicing of the site.





## 2.0 Background

Documents referenced in preparing of this stormwater and servicing report for the 8 Withrow Avenue development include:

- *City of Ottawa Sewer Design Guidelines (SDG)*, City of Ottawa, October 2012, including all subsequent technical bulletins
- *City of Ottawa Design Guidelines – Water Distribution*, City of Ottawa, July 2010, including all subsequent technical bulletins
- *Design Guidelines for Drinking Water Systems*, Ministry of the Environment, Conservation, and Parks (MECP), 2008
- *Fire Protection Water Supply Guideline for Part 3 in the Ontario Building Code*, Office of the Fire Marshal (OFM), October 2020
- *Water Supply for Public Fire Protection*, Fire Underwriters Survey (FUS), 2020
- *Geotechnical Investigation – Proposed Mixed Use Building – 8 Withrow Avenue*, Paterson Group, February 25, 2020
- *Phase I Environmental Site Assessment – 8 Withrow Avenue*, Paterson Group, December 9, 2019
- *Phase II Environmental Site Assessment – 8 Withrow Avenue*, Paterson Group, February 15, 2020



## 3.0 Potable Water Servicing

### 3.1 Background

The existing watermain along the boundaries of the site consist of a 150 mm diameter cast iron watermain within Withrow Avenue, a 200 mm diameter cast iron watermain within Rossland Avenue, and a 300mm diameter ductile iron watermain within Merivale Road. The Withrow Avenue watermain is within the City of Ottawa water distribution system 'ME' pressure zone and the Rossland Avenue watermain is within the '2W2C' pressure zone. There are existing fire hydrants on Rossland Avenue and Withrow Avenue that offer a total of four hydrants in proximity to the site. Prior to installation of potable water servicing infrastructure, the existing water service laterals are to be blanked at the main by the City of Ottawa.

### 3.2 Water Demands

#### 3.2.1 POTABLE (DOMESTIC) WATER DEMANDS

Preliminary potable water demands are calculated using the City of Ottawa Water Distribution Guidelines (2010) as amended, and ISTB 2021-03 Technical Bulletin (see detailed calculations in **Appendix B.1**).

The proposed development consists of 27 three-storey stacked and back-to-back townhouse units; and in the eight-storey apartment building, one studio unit, 22 one-bedroom units, 20 two-bedroom units, 14 three-bedroom units, and 373 m<sup>2</sup> of institutional space. The population is estimated using an occupancy of 2.7 persons per unit for townhouses, 1.4 persons per unit for studio and one-bedroom apartments, 2.1 persons per unit for two-bedroom apartments, and 3.1 persons per unit for three-bedroom apartments. The proposed site is estimated to have a total projected population of 191 residents.

A daily rate of 280 L/cap/day is used to estimate average daily (AVDY) potable water demand for the residential units, and 28,000 L/gross ha/day for the institutional spaces. The maximum day (MXDY) demand is determined by multiplying the AVDY demands by a factor of 2.5 for residential areas and 1.5 for institutional areas. Peak hourly (PKHR) demand is determined by multiplying the MXDY by a factor of 2.2 for residential areas and 1.8 for institutional areas. The estimated demand for the institutional and residential uses are summarized in **Table 3.1**.



**Table 3.1: Estimated Domestic Water Demands**

<b>Demand Type</b>	<b>Population</b>	<b>Gross Parcel Area (ha)</b>	<b>AVDY (L/s)</b>	<b>MXDY (L/s)</b>	<b>PKHR (L/s)</b>
Institutional		0.04	0.01	0.02	0.03
<b>Institutional Subtotal</b>		<b>0.04</b>	<b>0.01</b>	<b>0.02</b>	<b>0.03</b>
Townhouses	73	-	0.24	0.59	1.30
Apartment	118	-	0.38	0.95	2.10
<b>Residential Subtotal</b>	<b>191</b>	<b>-</b>	<b>0.62</b>	<b>1.54</b>	<b>3.40</b>
<b>Total Site</b>			<b>0.63</b>	<b>1.56</b>	<b>3.43</b>

### **3.2.2 FIRE FLOW DEMANDS**

Preliminary fire flow requirements are estimated using the Fire Underwriters Survey (FUS) methodology (2020). The FUS estimate for the townhouse blocks assumes buildings of wood frame construction type with two-hour fire rated structural members, but without full protections of all vertical openings (one hour fire rating). Confirmation of type of construction and specifics of fire suppression equipment (such as automatic sprinkler systems) will be provided by the Architect at detailed design. As per page 22 of the *Fire Underwriters Survey's Water Supply for Public Fire Protection (2020)*, the gross construction area of all floors immediately above ground level, up to a maximum of eight floors, is then used for the purpose of the FUS calculation. Additionally, it is anticipated that all buildings onsite will be equipped with automatic sprinkler systems that are not fully supervised and conform to the NFPA 13 standard.

The worst-case fire flow is determined to be approximately 10,000 L/min (167.0 L/s) for the 15-unit, three-storey, stacked and back-to-back townhouse unit fronting Rossland Avenue. Detailed fire flow calculations per the FUS methodology are provided in **Appendix B.2**. Please note that a fire flow requirement (FFR) of 15,000 L/min (250 L/s) had initially been determined, however, this emergency condition could not be met based on the pressure and flow available from the municipal watermain in Rossland Avenue. To reduce the overall FFR for the site, automatic sprinkler systems conforming to the NFPA 13 standard are proposed in the townhouse units. Similarly, vertical fire walls could be used to divide the townhouse block into smaller units and effectively reduce the FFR. The automatic sprinkler system is the preferred option of the Architects at the time of the ZBA application.

## **3.3 Level of Servicing**

### **3.3.1 BOUNDARY CONDITIONS**

The estimated domestic water and fire flow demands are used to confirm the level of servicing available for the proposed development from the adjacent municipal watermain and hydrants. **Table 3.2** outlines the hydraulic grade line (HGL) elevation boundary conditions provided by the City of Ottawa on July 24, 2023 (see **Appendix B.3** for correspondence). Based on the proposed connection from the site, only the data associated with Rossland Avenue (pressure zone '2W2C') is presented.



**Table 3.2: Boundary Conditions**

HGL Condition	Elevation (m)
Minimum HGL	125.4
Maximum HGL	133.3
Max. Day + Fire Flow (167.0 L/s) HGL	118.9

With onsite fire flow reduction measures proposed, the FFR is expected to be no greater than 10,000 L/min (167 L/s) within the site, as reflected in the Boundary Conditions.

### **3.3.2 ALLOWABLE DOMESTIC PRESSURES**

The desired normal operating pressure range in occupied areas as per the City of Ottawa (2010) Water Distribution Design Guidelines is 345 kPa to 552 kPa (50 psi to 80 psi) under a condition of maximum daily demand and no less than 276 kPa (40 psi) under a condition of maximum hourly demand. Furthermore, the maximum pressure at any point in the water distribution should not exceed 689 kPa (100 psi) as per the Ontario Building/Plumbing Code; pressure reducing measures are required to service areas where pressures greater than 552 kPa (80 psi) are anticipated in occupied areas.

The proposed finished floor elevation for the first floor of the apartment and church building at 97.3 m, serves as the reference elevation for the calculation of residual pressures at ground level. From the boundary condition HGL elevations, the onsite pressures at ground level are expected to range from 276 kPa to 352 kPa (40 psi to 51 psi) under normal operating conditions.

To ensure adequate water pressure above the ground floor elevation, booster pump requirements are to be confirmed by the mechanical engineer.

### **3.3.3 ALLOWABLE FIRE FLOW PRESSURES**

The boundary conditions and comments provided by the City of Ottawa indicate that the watermain within Rossland Avenue is expected to maintain a residual pressure of 213 kPa (22 psi) under the required fire flow of 10,000 L/min (167 L/s), per the hydraulic boundary condition correspondence provided in **Appendix B.3**. This demonstrates that the watermains and nearby fire hydrants can provide the required fire flow and max. day domestic flows while maintaining the minimum residual pressure of 138 kPa (20 psi).

### **3.3.4 FIRE HYDRANT COVERAGE**

The buildings will be sprinklered and a Siamese (fire department) connection is to be provided at the entrance to each building. There are four hydrants in the proximity of the proposed development site as well as one hydrant proposed onsite, as shown in **Figure 3-1**. The distance from each hydrant to the proposed buildings is less than 133 m. Each Siamese connection will be situated within 45m of a fire hydrant.



**Adequacy of Public Services Report - Julian of Norwich (8 Withrow Avenue and 7 Rossland Avenue)  
Potable Water Servicing**

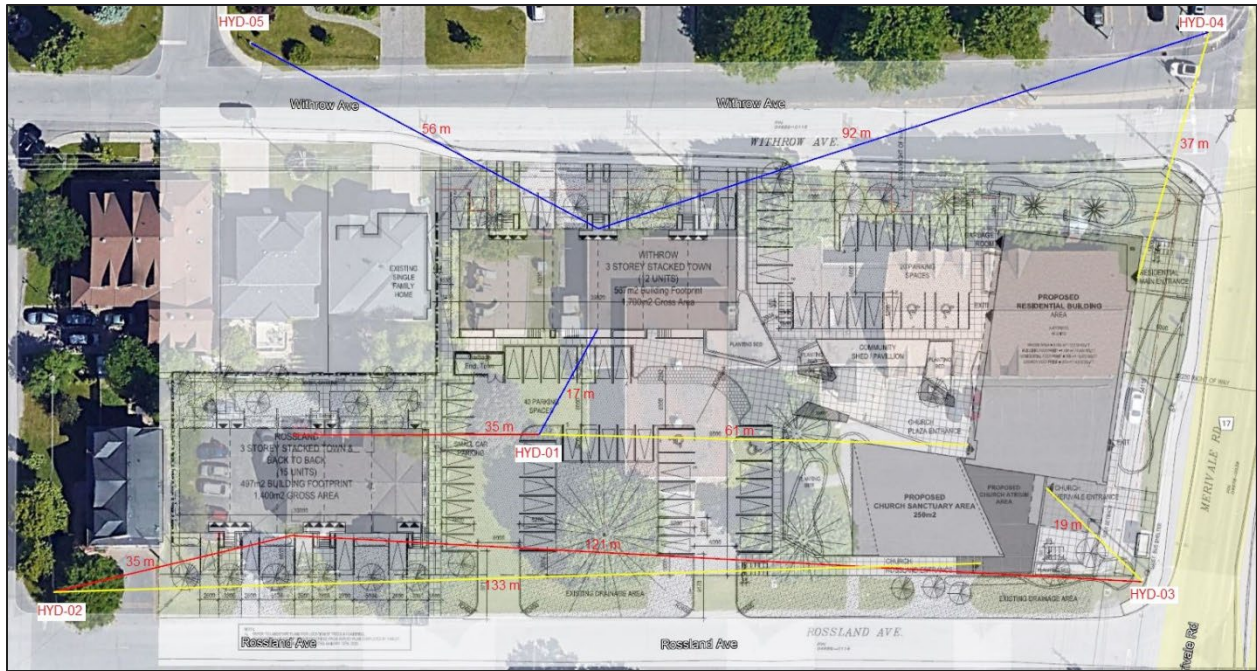

**Figure 3-1: Fire Hydrant Coverage Sketch**

According to the NFPA 1 Table 18.5.4.3, a hydrant situated less than 76 m away from a building can supply a maximum capacity of 5,678 L/min, while a hydrant 76 to less than 152 m away can supply a maximum capacity of 3,785 L/min. Hence, the required fire flow for the 15-unit townhouse building (10,000 L/min) can be achieved with a combination of HYD-01, HYD-02 and HYD-03. Other buildings can similarly be covered by a combination of two nearest hydrants, as shown in **Table 3.3** See **Appendix B.4** for fire hydrant coverage table calculations and NFPA Table 18.5.4.3.

Under the NFPA Table 18.5.4.3. assumptions, multiple hydrants are required to meet the RFF of each building. Consequently, a multi-hydrant hydraulic analysis is required to verify these emergency conditions using the city’s computer model simulation. A request for a multi-hydrant hydraulic analysis was submitted to the city on October 23, 2023 (see **Appendix B.5**). The results of this request will be included in the following submission.

**Table 3.3: Fire Hydrant Coverage Table**

Building	Hydrants
15-Unit Townhouse, fronting Rossland	HYD-01, HYD-02, HYD-03
12-Unit Townhouse, fronting Withrow	HYD-01, HYD-04, HYD-05
8-Storey Apartment Building and Church	HYD-01, HYD-03, HYD-04



### **3.4 Proposed Water Servicing**

The development is to be serviced via a network of private internal watermain pipes supported with a dual 200mm diameter connection, to the existing 200 mm diameter watermain on Rossland Avenue. It is assumed that the stacked Withrow townhomes can be serviced from the rear, while watermain has been provided at the front and rear of the Rossland townhomes to accommodate the servicing of the stacked and back-to-back units. It is assumed that the community shed/pavilion will require a small water service lateral for a bib hose. Water service lateral sizing and alignments for individual units and community shed will be determined at detailed design. The proposed water servicing is shown on **Drawing SSP-1**. Based on City of Ottawa Design Guidelines, the existing 200 mm diameter watermain on Rossland Avenue can provide adequate fire and domestic flows for the subject site.

A dual water service connection, separated by an isolation valve, has been provided per City of Ottawa Water Distribution Guidelines, as amended, to avoid the development of a vulnerable service area. The isolation valve between the two service connections allows for the isolation of the municipal watermain to the east or west on Rossland Avenue in case of any breaks, repairs, or replacements of the municipal water system west or east of the Site. Both services will connect to the watermain with TVS (tapping valve and sleeve) connections which allow for the individual service connection to be isolated from the private watermain.

A DMA (flow monitoring chamber) is provided onsite near the dual watermain connection as per City Standard W3 and as indicated in the pre-consultation minutes. Metering requirements for individual building services will be addressed at the detailed design (SPC) phase, in consultation with the mechanical engineering consultant. Confirmation of the service sizes to each building, the water pressure within each building, and booster pump requirements to meet building code will be the responsibility of the mechanical engineering consultant at detailed design.



## 4.0 Wastewater Servicing

### 4.1 Background

The existing sanitary sewer along the boundaries of the site consists of 200 mm diameter asbestos concrete pipes within Withrow Avenue and Rossland Avenue, and a 250mm diameter concrete pipe within Merivale Road.

### 4.2 Design Criteria

As outlined in the City of Ottawa Sewer Design Guidelines and the MECP Design Guidelines for Sewage Works, the following criteria are used to calculate the estimated wastewater flow rates and to determine the size and location of the sanitary service lateral:

- Minimum velocity = 0.6 m/s (0.8 m/s for upstream sections)
- Maximum velocity = 3.0 m/s
- Manning roughness coefficient for all smooth wall pipes = 0.013
- Minimum size of sanitary sewer service = 135 mm
- Minimum grade of sanitary sewer service = 1.0 % (2.0 % preferred)
- Average wastewater generation = 280 L/person/day (per City Design Guidelines)
- Peak Factor = based on Harmon Equation; maximum of 4.0 (residential)
- Harmon correction factor = 0.8
- Infiltration allowance = 0.33 L/s/ha (per City Design Guidelines)
- Minimum cover for sewer service connections = 2.0 m
- Population density for studio and one-bedroom apartments = 1.4 persons/apartment
- Population density for two-bedroom apartments = 2.1 persons/apartment
- Population density for three-bedroom apartments = 3.1 persons/apartment
- Population density for townhouses = 2.7 persons/unit

### 4.3 Wastewater Generation and Servicing Design

The proposed development consists of 27 three-storey stacked and back-to-back townhouse units; and in the eight-storey apartment building, one studio unit, 22 one-bedroom units, 20 two-bedroom units, 14 three-bedroom units, and 373 m<sup>2</sup> of institutional space. The anticipated peak wastewater flow generated from the proposed development is summarized in **Table 4.1** below.

**Table 4.1: Estimated Peak Wastewater Flow**

Peak Residential Wastewater Flow			Institutional Wastewater Flow	Infiltration Flow (L/s)	Total Peak Flow (L/s)
Population	Peak Factor	Peak Flow (L/s)			
191	3.5	2.18	0.03	0.26	2.5



**Adequacy of Public Services Report - Julian of Norwich (8 Withrow Avenue and 7 Rossland Avenue)  
Wastewater Servicing**

Preliminary sanitary sewage calculations are included in **Appendix C.1**.

The anticipated peak wastewater flows for the proposed development were provided to the City of Ottawa staff to evaluate the adequacy of the receiving municipal sanitary sewer system in the vicinity of the site and downstream network. Confirmation was obtained that the additional 2.5 L/s of peak sanitary flow from the proposed site is negligible for the downstream sanitary sewers, therefore there is capacity for the additional sanitary peak flow from the development (see correspondence in **Appendix C.2**).

#### **4.4 Proposed Sanitary Servicing**

The development is to be serviced via a gravity network of private (internal) sanitary sewer pipes and manholes. It is assumed that the stacked Withrow townhomes can be serviced from the rear, while sanitary sewer has been provided at the front and rear of the Rossland townhomes to accommodate the servicing of the stacked and back-to-back units. Sanitary service laterals for individual townhome units will be determined at detailed design. The private sanitary sewer network is to outlet through a sanitary monitoring manhole (anchored as per S.P. No. F-4070) before connecting to the existing sanitary manhole (labelled MHSA 17468 on GeoOttawa) and the 200 mm diameter sanitary sewer in Rossland Avenue. The proposed functional sanitary servicing is shown on **Drawing SSP-1 and SA-1**.

The mechanical engineering consultant is responsible to confirm service lateral sizes and that the appropriate backwater valve requirements are satisfied.





## 5.0 Stormwater Management and Servicing

### 5.1 Background

The existing storm servicing system along the boundaries of the site consists of curb and catch basins (urban roadway section) along Merivale Road; a hybrid roadway section with curb and catch basins on the south side of Withrow Avenue, and a ditch/culvert arrangement along the north side of Withrow Avenue; and a rural section along Rossland Avenue with a ditch/culvert system on the north and south sides of the roadway. The ditches on Withrow and Rossland are scheduled to be reopened within the next 2-5 years. At the intersection of Withrow Avenue and Merivale Road, ditch inlet catch basins and curb inlet catch basins direct drainage to a 375 mm concrete storm sewer that connects to the 525 mm concrete storm sewer in Merivale Road. At the intersection of Rossland Avenue and Merivale Road, ditch inlet catch basins direct drainage to a 300 mm concrete storm sewer that connects to the 525 mm concrete storm sewer in Merivale Road.

### 5.2 Stormwater Management (SWM) Criteria

The Stormwater Management (SWM) criteria are established by combining current design practices outlined by the City of Ottawa Sewer Design Guidelines (SDG) (October 2012), as amended, review of project pre-consultation notes with the City of Ottawa, and through consultation with City of Ottawa staff. The following summarizes the criteria, with the source of each criterion indicated in brackets:

#### General

- Use of the dual drainage principle (City of Ottawa SDG)
- Wherever feasible and practical, site-level measures should be used to reduce and control the volume and rate of runoff (City of Ottawa SDG)
- Assess impact of 100-year event outlined in the City of Ottawa Sewer Design Guidelines on the major and minor drainage systems (City of Ottawa SDG)

#### Storm Sewer and Inlet Controls

- Discharge for each storm event to be restricted to a 2-year storm event pre-development rate with a maximum pre-development C coefficient of 0.5 (City of Ottawa pre-consultation, **Appendix F**)
- Peak flows generated from events greater than the 2-year and including the 100-year storm must be detained onsite (City of Ottawa pre-consultation, **Appendix F**)
- The preferred stormwater system outlets for this site are the 375 mm diameter storm sewer stub in Withrow Avenue and 300 mm diameter storm sewer stub in Rossland Avenue, both which connect to the 525 mm diameter storm sewer in Merivale Road. (City of Ottawa pre-consultation, **Appendix F**)
- The foundation drainage system is to be independently connected to sewer main unless being pumped with appropriate back up power, sufficient sized pump, and backflow prevention. (City of Ottawa pre-consultation, **Appendix F**)



**Adequacy of Public Services Report - Julian of Norwich (8 Withrow Avenue and 7 Rossland Avenue)**  
**Stormwater Management and Servicing**

- Tc should be not less than 10 minutes since IDF curves become unrealistic at less than 10 min (City of Ottawa SDG).

**Surface Storage and Overland Flow**

- Building openings to be a minimum of 0.30 m above the 100-year water level (City of Ottawa SDG)
- Maximum depth of flow under either static or dynamic conditions shall be less than 0.30 m (City of Ottawa SDG)
- Provide adequate emergency overflow conveyance off-site with a minimum vertical clearance of 0.15 m between the spill elevation and the ground elevation at the building envelope in the proximity of the flow route or ponding area (City of Ottawa SDG)

**Quality Control**

- MVCA to provide criteria related to quality control criteria (City of Ottawa pre-consultation, **Appendix F**). Due to Bill 23 and the changes to the Conservation Authority Act, the City of Ottawa now provides the SWM Quality Control Criteria. An enhanced level of quality control of 80% Total Suspended Solids (TSS) Removal is required for this site (consultation with City of Ottawa Staff, **Appendix D.3**)

## **5.3 Existing Conditions**

The 0.72 ha site area currently consists of an existing church with two-storey accessory building on the eastern portion of the property, access lanes, paved and gravel parking lots, a playground, green landscaped areas, and another detached accessory church community building on the western portion of the property. **Drawing EX-SD** (Existing Storm Drainage Plan) shows the existing surface conditions and related runoff coefficients considered. The pre-development imperviousness of the proposed development area is calculated at 49% ( $C = 0.54$ ). Under existing conditions there are no controls in place to manage stormwater runoff and all runoff the from site boundary drains uncontrolled to the existing public drainage system. Review of publicly available LiDAR data confirms that there are no significant external drainage areas draining into this property, thus only onsite drainage will require stormwater management.

## **5.4 Stormwater Management Design**

The Modified Rational Method is employed to assess the rate and volume of runoff anticipated during post-development rainfall runoff events. Based on the proposed Site Plan and preliminary Grading Plan, drainage area boundaries are defined, Runoff coefficient values are then assigned to each drainage area based on the anticipated finished surface condition (e.g. asphalt, concrete, gravel, grass, etc.). Runoff coefficients for each surface type are assigned based on City of Ottawa SDG and accepted practices. A summary of drainage areas and runoff coefficients are provided in **Table 5.1** below. Further details can be found in **Appendix D.1**, while **Drawing SD-1** illustrates the proposed post-development drainage conditions.



**Table 5.1: Summary of Post-Development Drainage Areas**

<b>Catchment Areas</b>	<b>Runoff Coefficient, C</b>	<b>Area (ha)</b>	<b>Catchment Type <sup>1</sup></b>	<b>Outlet</b>
SITE-1	0.77	0.436	Tributary	300 mm Storm Sewer Extension (Rossland Ave. ROW)
ROOF-1	0.90	0.080	Tributary	300 mm Storm Sewer Extension (Rossland Ave. ROW)
UNC-1	0.53	0.080	Non-Tributary	Rossland Ave. ROW
UNC-2	0.53	0.124	Non-Tributary	Withrow Ave. ROW, Rossland Ave. ROW, Merivale Road ROW

1. Catchment Type refers to the nature of the catchment's outlet. Tributary catchments contribute to the onsite stormwater management systems.

### 5.4.1 ALLOWABLE RELEASE RATE

Based on pre-consultation with City of Ottawa staff, the peak post-development discharge from the subject site is to be limited to the discharge resulting from the 2-year pre-development event using a site runoff coefficient of  $C = 0.5$  or the pre-development  $C$ , whichever is less. Based on the calculated  $C$  value of 0.54 for the existing site condition, a runoff coefficient of 0.5 is used to establish the allowable release rate.

Given the limitations of site grading based on the existing topography, and the existing uncontrolled runoff condition for the site, it is proposed that the post-development drainage pattern for the uncontrolled areas (UNC-1 and UNC-2) around the site perimeter be allowed to continue to drain uncontrolled to the adjacent public roads. The resultant areas that can be restricted to the allowable release rate is then limited to drainage areas defined by 'SITE-1' and 'ROOF-1', totalling 0.516 ha.

The allowable release rate for the site is determined using the modified rational method based on the criteria above. A time of concentration of 10 minutes is used based on the small site size, its proximity to the existing drainage outlet, and recommendations provided during pre-consultation with the City.

$$Q = 2.78 (C)(I)(A)$$

Where:

$Q$  = peak flow rate, L/s

$C$  = site runoff coefficient

$I$  = rainfall intensity, mm/hr (per City of Ottawa IDF curves)

$A$  = drainage area, ha

$$\text{Intensity (mm/hr)} = \frac{732.951}{(10 + 6.199)^{0.810}} = 76.81 \text{ mm/hr}$$

$$Q = 2.78(0.50)(76.81\text{mm/hr})(0.516 \text{ ha}) = \mathbf{55.09 \text{ L/s}}$$



**Table 5.2: Allowable Target Release Rate**

<b>Design Storm</b>	<b>Pre-Development Flow Rate (L/s)</b> for C=0.50, A=0.516 ha, Tc = 10 min
2-Year	55.1

For the proposed development, the target allowable release rate of 55.1 L/s is used to assess water quantity control measures to be applied.

#### **5.4.1.1 Uncontrolled Areas**

As specified above, considering the existing conditions of the site and the grading restrictions along the site’s perimeter, it is proposed to control the interior of the site and the mid-rise apartment building roof area only and allow the rest of the site to drain uncontrolled. The drainage area UNC-1 will direct uncontrolled surface runoff to the adjacent ditch along Rossland Avenue. The drainage area UNC-2 will direct uncontrolled surface runoff to the Withrow Avenue, Merivale Road, and the northeast corner of the Rossland Avenue ROW. Peak discharges from the uncontrolled areas are calculated using the Modified Rational Method (MRM) approach and are summarized in the table below.

**Table 5.3: Peak Post-Development Discharge of Uncontrolled Areas (UNC-1, UNC-2)**

<b>Uncontrolled Drainage Area</b>	<b>Design Storm</b>	<b>Post-Development Discharge (L/s)</b>
UNC-1	2-Year	9.1
	100-Year	26.3
UNC-2	2-Year	14.0
	100-Year	40.8

The proposed uncontrolled runoff condition from 0.20 ha is considered an improvement over the existing condition during which the full site area of 0.72 ha contributes uncontrolled runoff to the existing public drainage system.

For reference, the uncontrolled runoff rates for the existing 0.72 ha site area (applying the 0.54 runoff coefficient) are 83.6 L/s for the 2-year return period, and 222.3 L/s for the 100-year return period design storms.

#### **5.4.2 QUANTITY CONTROL**

Based on the change in overall imperviousness of the site, expressed by the calculated runoff coefficients, quantity control measures are needed to manage stormwater runoff. It is proposed that a combination of rooftop capture, surface storage, and underground storage be used to reduce the site’s peak outflow. A spreadsheet approach using the MRM is used to determine the storage volume required. The associated calculations consider the allowable release rate of 55.1 L/s from the controlled areas tributary to the proposed SWM underground storage and the runoff coefficients associated with the



**Adequacy of Public Services Report - Julian of Norwich (8 Withrow Avenue and 7 Rossland Avenue)  
Stormwater Management and Servicing**

proposed post-development catchments. The MRM calculations used to establish the storage volume requirement is provided in **Appendix D.1** and the storm sewer design sheet is provided in **Appendix D.2**.

A storage volume of **134 m<sup>3</sup>** is required to attenuate peak flows from these areas for release at a controlled flow rate of **55 L/s**.

### 5.4.3 QUALITY CONTROL

To meet the expected quality control requirements for the site, storm runoff from the proposed development area will be captured within the site storm sewer system and directed to a proposed oil/grit separator (OGS) unit. A Stormceptor, or approved equivalent product, designed to provide 80% TSS removal is anticipated to achieve the enhanced water quality control objective. Correspondence with the City of Ottawa regarding the site’s quality control requirements can be found in **Appendix D.3** and the preliminary sizing of a feasible Stormceptor unit is provided in **Appendix D.4**.

## 5.5 Results

Through the MRM analysis, the controlled 2-year post-development release rate of 55 L/s meets the pre-development target release rate of 55.1 L/s. In addition, the 100-year post-development storm event release rate will be maintained at the 55 L/s allowable target. The uncontrolled portions of the site with runoff draining to the adjacent ROWs are consistent with the existing drainage pattern.

Relative to the existing site condition with 100% uncontrolled runoff, the proposed post-development 2-year flow control for 0.516 ha of the site is anticipated to reduce the total stormwater discharge from the site. The data summarized in **Table 5.4** indicates that the proposed SWM plan reduces the overall site storm runoff release rate by 45% compared to the pre-development C=0.54, 100-year design storm event.

**Table 5.4: Comparison of Pre- and Post-Development Release Rates**

Drainage Area	2-Year Discharge (L/s)	100-Year Discharge (L/s)
Pre-Development Total (0.72 ha)	83.6	222.3
Post-Development		
UNC-1 + UNC-2 (0.20 ha)	23.1	67.1
SITE-1 + ROOF 1 (0.52 ha)	55.0	55.0
Post-Development Total (0.72 ha)	78.1	122.1
<b>Difference (Post minus Pre)</b>	<b>-5.5 (-6.6%)</b>	<b>-100.2 (-45.1%)</b>

## 5.6 Proposed Stormwater Servicing

The development is to be serviced via a network of private (internal) storm sewer pipes which will receive the runoff from the roof (ROOF-1) and site (SITE-1) areas. A design sheet confirming the adequacy of the



**Adequacy of Public Services Report - Julian of Norwich (8 Withrow Avenue and 7 Rossland Avenue)**  
**Stormwater Management and Servicing**

preliminary storm sewer infrastructure sizing is included in **Appendix D.2**. Stormwater detention infrastructure (e.g., cistern, underground linear pipe storage, rooftop storage, etc.) with a minimum storage volume capacity of **134 m<sup>3</sup>** will be provided onsite and discharged from the proposed development at a controlled flow rate of **55 L/s**. The final sizing and layout of the infrastructure, including the method(s) of flow attenuation, shall be confirmed at detailed design. Hydraulic grade lines in the proposed storm sewer system will also be evaluated at detailed design. The preliminary stormwater management concept has been aligned with the Site Plan to minimize the impacts to the existing high-value trees onsite that are to be preserved. The storm sewers and proposed underground storage facility respect the CRZs of the existing trees to be retained. See **Drawing SSP-1 and Drawing SD-1** for the proposed preliminary locations of the stormwater infrastructure.

It is assumed that the roofs of both townhome blocks will be sloped (continuous from front to back) to drain toward the interior of the site to the private storm sewer system. One foundation drain will be provided per building and will also connect to the private storm sewer system. It is assumed that the proposed church and mid-rise apartment building will share a common foundation and drain so only one storm service lateral is anticipated for those buildings. Storm service laterals, catch basins, catch basin leads, and rear-yard stormwater infrastructure locations and alignments will be determined at detailed design.

The mechanical engineering consultant is responsible to confirm service sizes to each building, that the appropriate backwater valve requirements are satisfied, and that any roof drainage systems (including potential internal storage systems, roof drains, and scuppers) are adequate for accommodating the 100-year design storm conditions.

From the location of the site storm sewer outlet, a new 300 mm storm sewer extension in Rossland Avenue is proposed. The new storm sewer originates at the upstream manhole (GeoOttawa MHST20225) of the existing 300 mm concrete storm sewer at the intersection of Rossland Avenue and Merivale Road. The existing 300 mm concrete storm sewer connects and outlets to the 525 mm concrete storm sewer in Merivale Road which drains south.

The existing ditch conveyance along the north side of Rossland Avenue is to be maintained with the installation of culverts across the new proposed driveway access locations. All other existing drainage patterns and storm sewer connections in Rossland Avenue will remain unchanged. No changes to the storm servicing infrastructure within Withrow Avenue or Merivale Road are proposed.



## **6.0 Site Grading**

The proposed re-development site measures approximately 0.72 ha in area and consists of existing church buildings, asphalt areas, storm drainage ditches along Rossland Avenue, sidewalk along Withrow Avenue, and lawn/grassed areas. The topography across the site generally slopes from the west towards the Merivale Road ROW at the east, and from the middle towards the Withrow Avenue ROW at the north and the Rossland Avenue ROW at the south.

A functional grading plan (see **Drawing GP-1**) is provided to support the stormwater management review presented in **Section 5.0**. The functional grading scheme considers emergency overland flow routes required for stormwater management and anticipated cover requirements over sanitary and storm sewers. It provides preliminary high and low point elevations in critical areas to demonstrate the overall drainage patterns. The functional grading plan has been aligned with the Site Plan and preliminary SWM concept to minimize the impacts to the existing high-value trees onsite that are to be retained. The plan ties-in to existing elevations at the property lines and no drainage is directed to the adjacent properties. Terracing is proposed along the northwest property line to tie-in to the adjacent residential property on Withrow Avenue.

Underside of footing (USF) and finished floor elevations are to be provided or confirmed at detailed design. Each building will have one basement level. The proposed USFs, basement floor elevations, and entrance/egress risers will be coordinated with the architect to align with building elevation plans and respect the proposed storm sewer's hydraulic grade lines. The mechanical engineering consultant is responsible to provide the sump pit and sump pump designs if required.

The existing ditch along Rossland Avenue will be reinstated by the city in the upcoming years. For this project, the ditch is to be retained and sufficient setbacks are to be provided. This site will include a culvert at each entrance in accordance with city size, thickness, material, and cover specifications. Grading provided at detailed design and SPC will allow for ditch reinstatement and 3:1 backslopes.



## **7.0 Utilities**

Hydro Ottawa, Bell, Rogers, and Enbridge all have existing utility plants in the area, which are anticipated to be used to service this site. The exact size, location, and routing of utilities is to be finalized during detailed design.

Overhead (OH) hydro-wires run north-south along the eastern property line, east-west along the northern property line, and diagonally from the west and Rossland Avenue to the existing buildings onsite. An existing 50 mm diameter gas line runs roughly along the centreline of the Rossland Avenue north ditch.

The existing utility poles, overhead wires, and utility plants within the public right of way and easement instruments are to be protected during construction. Some may need to be temporarily moved or reconfigured to allow sufficient clearance for the movement of heavy machinery during construction. All utilities within the work area will require relocation during construction. The relocation of existing utilities is to be coordinated with the individual utility providers as needed. Utility easement instruments will require registration on the Registered Plan (R-Plan) of the property.





## **8.0 Approvals**

The proposed development lies on a private site under singular ownership; drains to an approved separated sewer outlet; and is not intended to service industrial land or land uses. Therefore, the onsite work is exempt from the Ministry of the Environment, Conservation and Parks (MECP) Environmental Compliance Application (ECA) process under O.Reg. 525/98. However, the extension of the storm sewer in the Rossland Avenue municipal right of way will require an MECP ECA approval. This process will likely qualify for the Delegated Authority Review by the City of Ottawa.

For ground or surface water volumes being pumped during the construction phase, typically between 50,000 to 400,000 L/day, it is required to register on the Environmental Activity and Sector Registry (EASR). It is possible that groundwater may be encountered during the foundation excavation on this site. A minimum of two to four weeks should be allotted for completion of the EASR registration and the preparation of the Water Taking and Discharge Plan by a Qualified Person as stipulated under O.Reg. 63/16. An MECP Permit to Take Water (PTTW), which is required for dewatering volumes exceeding 400,000 L/day, is not anticipated for the site.



## **9.0 Erosion and Sediment Control During Construction**

To protect downstream water quality and prevent sediment build-up in catch basins and storm sewers, erosion and sediment control measures must be implemented during construction. The following recommendations will be included in the contract documents and communicated to the Contractor.

1. Implement best management practices to provide appropriate protection of the existing and proposed drainage system and the receiving water course(s).
2. Limit the extent of the exposed soils at any given time.
3. Re-vegetate exposed areas as soon as possible.
4. Minimize the area to be cleared and grubbed.
5. Protect exposed slopes with geotextiles, geogrid, or synthetic mulches.
6. Install silt barriers/fencing around the perimeter of the site as indicated in **Drawing ECDS-1** to prevent the migration of sediment offsite.
7. Install track out control mats (mud mats) at the entrance/egress to prevent migration of sediment into the public ROW.
8. Provide sediment traps and basins during dewatering works.
9. Install sediment traps (such as SiltSack® by Terrafix) between catch basins and frames.
10. Schedule the construction works at times which avoid flooding due to seasonal rains.

The Contractor will also be required to complete inspections and guarantee the proper performance of their erosion and sediment control measures at least after every rainfall. The inspections are to include:

- Verification that water is not flowing under silt barriers.
- Cleaning and changing the sediment traps placed on catch basins.

Refer to **Drawing ECDS-1** in for the proposed location of silt fences, sediment traps, and other erosion control measures.



## 10.0 Geotechnical Investigation

A geotechnical investigation report was prepared by Paterson Group on February 25, 2020, to provide an assessment of the subsurface conditions found at the site. Five (5) boreholes were advanced to a maximum depth of 6.6 metres below the existing ground surface (BGS) in the investigation carried out on December 6, 2019, and January 20 and 21, 2020. The information obtained from the field investigation will guide the design of the site and identify development constraints.

The subsurface profile encountered at the borehole locations is characterized primarily by an asphalt pavement structure or a topsoil layer with a layer of brown silty sand and gravel fill or reworked native soil overlying a glacial till deposit, which consisted of sand and gravel with a clayey silt soil matrix.

Based on available geological mapping, the bedrock consists of interbedded limestone and dolomite of the Gull River formation. Bedrock was cored at borehole locations BH1 to BH3, where grey limestone was encountered at 2.5 to 2.8 m BGS, and the upper first meter was found to be of very poor to fair quality. Groundwater was encountered at BH1 to BH3 at 2.4 to 2.56 m BGS, though as groundwater levels are subject to seasonal fluctuations, they could vary at the time of construction.

Based on Paterson’s recommendations, the site is suitable for the proposed development. It is recommended that the mixed-use building be founded on conventional shallow footings placed on an approved soil and/or the bedrock bearing surface. Bedrock removal may be required to complete the underground level.

The recommended rigid pavement structure is further presented in **Table 10.1** below.

**Table 10.1: Recommended Pavement Structure**

<b>Material</b>	<b>Car Only Parking</b>	<b>Access Lanes and Heavy Truck Parking</b>
Wear Course – HL-3 or Superpave 12.5- Asphaltic Concrete	50 mm	40 mm
Binder Course – HL-8 or Superpave 19.0 Asphaltic Concrete	-	50 mm
BASE – OPSS Granular A Crushed Stone	150 mm	
SUBBASE – OPSS Granular B Type II	300 mm	450 mm

Refer to the full geotechnical report attached in as part of the submission package for further details.



## **11.0 Conclusions**

### **11.1 Potable Water Servicing**

Based on the supplied boundary conditions for existing watermains and calculated domestic and fire flow demands for the subject site, the adjacent watermain on Rossland Avenue has sufficient capacity to sustain the required domestic demands for the development. A new fire hydrant is proposed onsite to supplement the existing fire hydrants in the area. The municipal watermain has the capacity to provide fire flow demands for the site. The proposed development will be serviced by a network of private internal watermains, which will be connected to the existing 200 mm watermain on Rossland Avenue with a dual connection, separated by an isolation valve. Sizing of the water service laterals are to be confirmed by the mechanical engineering consultant.

### **11.2 Sanitary Servicing**

The proposed sanitary sewer service will consist of a network of private internal sanitary sewers directing wastewater to the existing 200 mm diameter sanitary sewer on Rossland Avenue. The municipal infrastructure has the downstream capacity required to receive the projected wastewater flows from this site. Existing connections are to be removed and full port backwater valves installed as needed. The buildings onsite are each expected to be serviced by 150 mm diameter sanitary service laterals. The final sizing and layout of the infrastructure shall be confirmed at detailed design. Sizing of the sanitary sewer laterals to each building and the appropriate backwater valve requirements are to be confirmed by the mechanical engineering consultant.

### **11.3 Stormwater Servicing and Management**

The proposed storm sewer service will consist of a network of private internal storm sewers directing stormwater to the extension of the 300 mm diameter storm sewer proposed in Rossland Avenue, and ultimately to the existing 525 mm diameter storm sewer in Merivale Road. The municipal infrastructure has the downstream capacity required to receive the projected stormwater flows from this site. . Stormwater management infrastructure (rooftop storage, cistern, linear pipe storage, etc.) with a minimum storage volume capacity of 134 m<sup>3</sup> will be provided onsite and discharged from the proposed development at a controlled flow rate of 55 L/s. The final sizing and layout of the infrastructure shall be confirmed at detailed design. Sizing of the storm sewer laterals and the appropriate backwater valve requirements are to be confirmed by the mechanical engineering consultant.

### **11.4 Grading**

Preliminary site grading is designed to provide an adequate emergency overland flow route and drainage to support the proposed storm sewer network and SWM systems. The north, east and south sides drain uncontrolled to the existing ditches in the adjacent rights-of-way as per existing conditions.



## **11.5 Erosion and Sediment Control During Construction**

Erosion and sediment control measures and best management practices outlined in this report and included in the drawing set, will be included in the contract documents, and communicated to the Contractor to reduce the impact on adjacent properties, the public ROW, and existing facilities during construction.

## **11.6 Geotechnical Investigation**

Based on the geotechnical investigation, the site is suitable for the proposed development. It is recommended that the buildings be founded on conventional shallow footings placed on an approved soil and/or the bedrock bearing surface. Bedrock removal may be required to complete the underground level. The report does not identify any permissible grade raise restrictions.

## **11.7 Utilities**

The site is situated within an established neighbourhood, hence existing utility infrastructure is readily available to service the proposed development. Overhead wires within and along the boundaries of the site need to be accommodated during construction. It is anticipated that existing infrastructure will be sufficient to provide a means of distribution for the proposed site. Exact size, locations and routing of utilities will be finalized after design circulation.

## **11.8 Approvals**

Preliminary review of the approval requirements found that the on-site work is exempt from the MECP ECA process under O.Reg. 525/98; however the storm sewer extension work within the Rossland Avenue ROW will require MECP ECA approval. For the expected dewatering needs of 50,000 to 400,000 L/day, the proponent will need to register on the MECP's Environmental Activity and Sector Registry (EASR). A Permit to Take Water, for dewatering needs exceeding 400,000 L/day, is not anticipated for this site.



# APPENDICES



## Appendix A Background Documents

### A.1 Site Plan



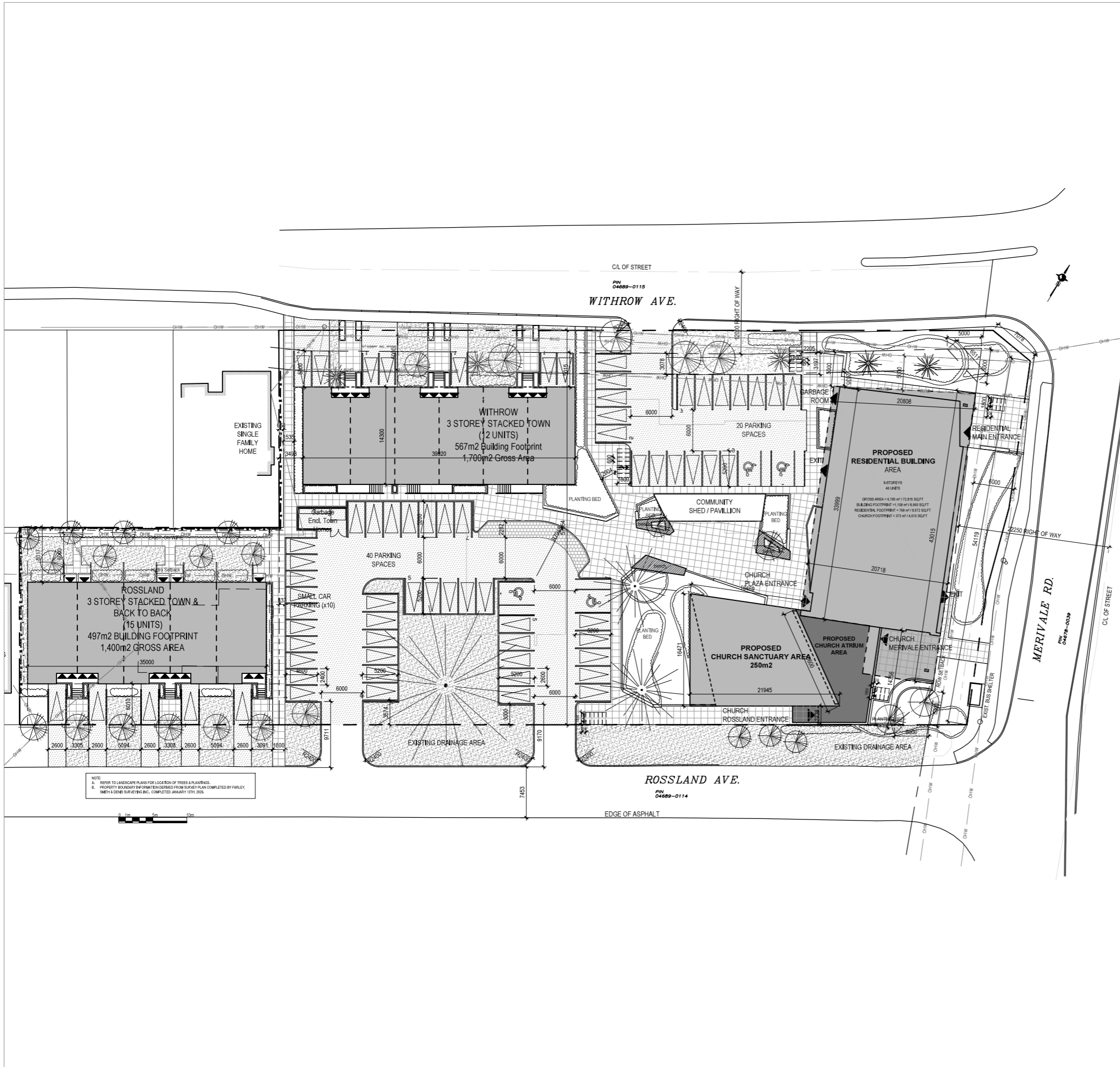

**KEY PLAN**

**PROPERTY DESCRIPTION**  
EIGHT STOREY RESIDENTIAL BUILDING, THREE STOREY TOWNHOUSES & ONE-STOREY CHURCH

**CITY OF OTTAWA PIN NUMBER** PART OF 04689 - 0001

**MUNICIPAL ADDRESS** 8 Withrow Avenue

**SITE INFORMATION**

LOT AREA: 6,114 m<sup>2</sup>  
 LOT FRONTAGE: 57.9 m  
 LOT DEPTH: 104.72 m

**BUILDING INFORMATION**

BUILDING AREA: TOWNHOUSES: 775 m<sup>2</sup>, APARTMENT BUILDING: 771 m<sup>2</sup>, CHURCH: 535 m<sup>2</sup>  
 BUILDING FLOOR AREA: TOWNHOUSES: 2,325 m<sup>2</sup>, APARTMENT BUILDING: 4,482 m<sup>2</sup>, CHURCH: 535 m<sup>2</sup>

**PROPOSED USE:** APARTMENT DWELLING MID-RISE, TOWNHOUSES, CHURCH

**APARTMENT UNIT BREAKDOWN:**

FIRST FLOOR:	0 UNITS	
SECOND FLOOR:	9 UNITS	1x STUDIO, 4x 1BD, 2x 2BD, 2x 3BD
THIRD FLOOR:	8 UNITS	0x STUDIO, 3x 1BD, 3x 2BD, 2x 3BD
FOURTH FLOOR:	8 UNITS	0x STUDIO, 3x 1BD, 3x 2BD, 2x 3BD
FIFTH FLOOR:	8 UNITS	0x STUDIO, 3x 1BD, 3x 2BD, 2x 3BD
SIXTH FLOOR:	8 UNITS	0x STUDIO, 3x 1BD, 3x 2BD, 2x 3BD
SEVENTH FLOOR:	8 UNITS	0x STUDIO, 3x 1BD, 3x 2BD, 2x 3BD
<b>TOTAL:</b>	<b>57 UNITS</b>	<b>1x STUDIO, 22x 1BD, 20x 2BD, 14x 3BD</b>

**TOWNHOME UNIT BREAKDOWN:**

WITHROW STACKED	12 UNITS	6x 2BD, 6x 3BD
ROSSLAND BACK TO BACK STACKED	15 UNITS	10x 2BD, 5x 3BD

**ZONING TABLE**

CITY OF OTTAWA ZONING BY-LAW No. 2008-250	REQUIRED	PROPOSED
MINIMUM LOT AREA AM10	No Minimum	7,214m <sup>2</sup>
MINIMUM LOT AREA I1B	1000m <sup>2</sup>	
MINIMUM LOT WIDTH AM10	No Minimum	57.8m
MINIMUM LOT WIDTH I1B	30m	
FRONT YARD SETBACK AM10	No Minimum	0m (Midrise along Carling)
FRONT YARD SETBACK I1B	6m	5.0m (TH @ Withrow) 5.0m (TH @ Rossland)
CORNER YARD SETBACK AM10	No Minimum	Midrise (0m along Rossland & 2.03 at Withrow)
CORNER YARD SETBACK I1B	6m	
HYDRO SETBACK	6m	6m (From closest OHL)
MIN. INTER. SIDE YARD SETBACK AM10	No Minimum (abutting institutional)	1.5m - Level 1 to 3
MIN. INTER. SIDE YARD SETBACK I1B	7.5m	2.5m - Level 4
MIN. REAR YARD SETBACK AM10	7.5m	7.8m Midrise rear face against the R11f zone
MIN. REAR YARD SETBACK I1B	7.5m	8.1m @ Rossland Townhomes
MAXIMUM BUILDING HEIGHT AM10	30 metres but in no case greater than nine storeys	26m (MID RISE BUILDING)
MAXIMUM BUILDING HEIGHT I1B	18m	
MAXIMUM FLOOR SPACE INDEX	N/A	
LANDSCAPED AREA	30% = 341.7m <sup>2</sup>	37% = 367m <sup>2</sup>
VEHICLE PARKING REQUIREMENTS (AREA C, SCHEDULE 1A)		
Dwelling	1.2 spaces/unit* = 84 x 1.2 = 100.8	0.5 spaces/unit* = 84 x 0.5 = 42
Place of Worship	10 spaces per 100 sqm of assembly area = 10 x (100) = 25	17 SPACES
Office	2.4 x (61m <sup>2</sup> / 100m <sup>2</sup> ) = 1.4	2.4 x (61m <sup>2</sup> / 100m <sup>2</sup> ) = 1.4
VEHICLE PARKING REQUIREMENTS (AREA C, SCHEDULE 1A)	0.2 / unit = 84 x 0.2 = 16.8	
AMENITY AREA REQUIREMENTS	6m <sup>2</sup> per dwelling unit = 504m <sup>2</sup> 50% Communal = 252m <sup>2</sup>	-575m <sup>2</sup> OUTDOOR AMENITY (including bicycle spaces) -100m <sup>2</sup> REAR SIDE YARD AMENITY -225m <sup>2</sup> INTERIOR ROOFTOP AMENITY -48m <sup>2</sup> BALCONIES TOTAL = 948m <sup>2</sup>
BICYCLE PARKING SPACES	0.5 per dwelling unit = 42	57 INTERIOR SPACES 27 EXTERIOR SPACES 1:1 ratio

**LEGEND**

- GRASS
- CONC. PAVERS TYPE 1
- UNIT PAVERS TYPE 1
- ASPHALT PAVING
- CONCRETE
- RIVER STONES. REFER TO LANDSCAPE
- FIRE ROUTE
- EXISTING FENCE
- NEW SCREEN FENCE
- NEW SOUND FENCE
- LOT LINE
- SETBACK LINE
- DESIGNATED BUILDING ENTRANCE / EXIT
- NEW FIRE HYDRANT. REFER TO CIVIL
- CATCH BASIN
- MANHOLE
- FLOOR DRAIN
- ELECTRICAL POST
- LIGHT STANDARD
- DEPRESSED CURB
- EXISTING TREE TO REMAIN (REFER TO LANDSCAPE DRAWINGS)
- NEW TREE (REFER TO LANDSCAPE DRAWINGS)
- NEW SHRUBS (REFER TO LANDSCAPE DRAWINGS)
- NEW EVERGREEN SHRUB (REFER TO LANDSCAPE DRAWINGS)
- EXISTING GROUND ELEVATION (TO DETERMINE EXISTING AVERAGE GRADE)
- PROPOSED GROUND ELEVATION. REFER TO CIVIL

NOTE: 'X-E' INDICATES EXISTING TO REMAIN

**FIGURI**

Architects / Architectes

190 Somerset St W #205  
Ottawa ON K2P 0J4  
T. 613 695-6122  
www.figuri.ca

**THE ANHOR JULIAN OF NORWICH**

8 WITHROW AVE  
OTTAWA ONTARIO

**SITE PLAN**

Drawn by / Dessiné par: RC  
 Checked by / Vérifié par: AS  
 Scale: AS SHCWV

No. / Date: 1 / 2023-06-30  
 Issued for / Issu pour: FOR ZONING SUBMISSION

Project / Projet: THE ANHOR JULIAN OF NORWICH

Site / Site: 8 WITHROW AVE, OTTAWA ONTARIO

Drawn by / Dessiné par: RC  
 Checked by / Vérifié par: AS  
 Scale: AS SHCWV

No. / Date: 1 / 2023-06-30  
 Issued for / Issu pour: FOR ZONING SUBMISSION



## A.2 Topographic Survey



Distance Note

Distances shown on this plan are ground distances and can be converted to grid distances by multiplying by the combined scale factor of 0.99994.

Bearing Note

Bearings are grid, derived from the southerly limit of Withrow Avenue having a bearing of N 58° 32' 15" E as shown on Registered Plan 375 and are referred to the Central Meridian of MTM Zone 9 (76°30' West Longitude) Nad-83 (Original).

Elevation Notes

- 1. Elevations shown are geodetic and are referred to Geodetic Datum CGVD-1928 :1978.
2. Elevations derived from Control Monument No.3702, Index No.67 having a published elevation of 96.951m.
3. It is the responsibility of the user of this information to verify that the job benchmark has not been altered or disturbed and that it's relative elevation and description agrees with the information shown on this drawing.

Utility Notes

- 1. This drawing cannot be accepted as acknowledging all of the utilities and it will be the responsibility of the user to contact the respective utility authorities for confirmation.
2. Only visible surface utilities were located.
3. Underground utility data derived from City of Ottawa utility sheet reference : L-04-12, L-04-06 and drawings 6521 (Sheet 3 of 3), 10151 (Sheet 9 of 36), 10158 (Sheet 8 of 34) & No. 11310.
4. Sanitary and storm sewer grades inverts were derived from field measurement. Sanitary and storm sewer inverts were compiled from City of Ottawa.
5. A field location of underground plant by the pertinent utility authority is mandatory before any work involving breaking ground, probing, excavating etc.

Notes & Legend

Denotes

- Survey Monument Planted
Survey Monument Found
Standard Iron Bar
Short Standard Iron Bar
Short Standard Iron Bar (0.30m Long)
Iron Bar
Round Iron Bar
Municipal Survey Monument
Subject To
Witness
Measured
Accepted North/South
Registered Plan 375
Plan 4R-1766
Plan 4R-2107
Plan 4R-2427
Plan 4R-2324
Plan 4R-21236
Plan 4R-19222
Plan by (AOG) dated March 9, 2001 (Job. No. 2232-01)
Plan by (1287) dated Aug. 30, 2007 (Job No. 432-06)
Plan by (1286) dated July 29, 2008 (Ref. No. 07-1103)
Maintenance Hole (Storm)
Maintenance Hole (Sanitary)
Maintenance Hole (Bell)
Maintenance Hole (Traffic)

- Underground Cable
Underground Traffic
Underground Storm Sewer
Underground Sanitary Sewer
Underground Water
Underground Power
Underground Gas
Underground Bell
Overhead Wires
Anchor
Light Standard
Catch Basin
Water Valve
Fire Hydrant
Water Stand Post
Gas Meter
Hydro Meter
Location of Wall/Curb Elevations
Top of Concrete Curb Elevation
Property Line
Deciduous Tree
Coniferous Tree

- Bell Terminal Box
Cable Terminal Box
Traffic Terminal Box
Unidentified Terminal Box
Traffic Signal Post
Bollard
Sign
Gate
Wood Pole
Metal Pole
Wood Pillar (0.189)
Air Conditioner
Diameter
Borehole
Chain Link Fence
Board Fence
Wire Fence
Window Well
Concrete Retaining Wall
Stone Retaining Wall
Timber Retaining Wall
Interlock Retaining Wall
Invert
Top of Grate
Top of Pipe
Underside of Eave
Foundation
Centreline
Ditch Inlet
Wood Pillar

TOPOGRAPHIC PLAN OF SURVEY OF

LOTS 136 TO 150 (BOTH INCLUSIVE), LOTS 371 TO 380 (BOTH INCLUSIVE), PART OF LOTS 128 TO 135 (BOTH INCLUSIVE) AND PART OF THE LANE (Closed by Judge's Order CR356848) REGISTERED PLAN 375 CITY OF OTTAWA

Scale 1: 250
Metric Note
Distances on this plan are in metres and can be converted to feet by dividing by 0.3048.

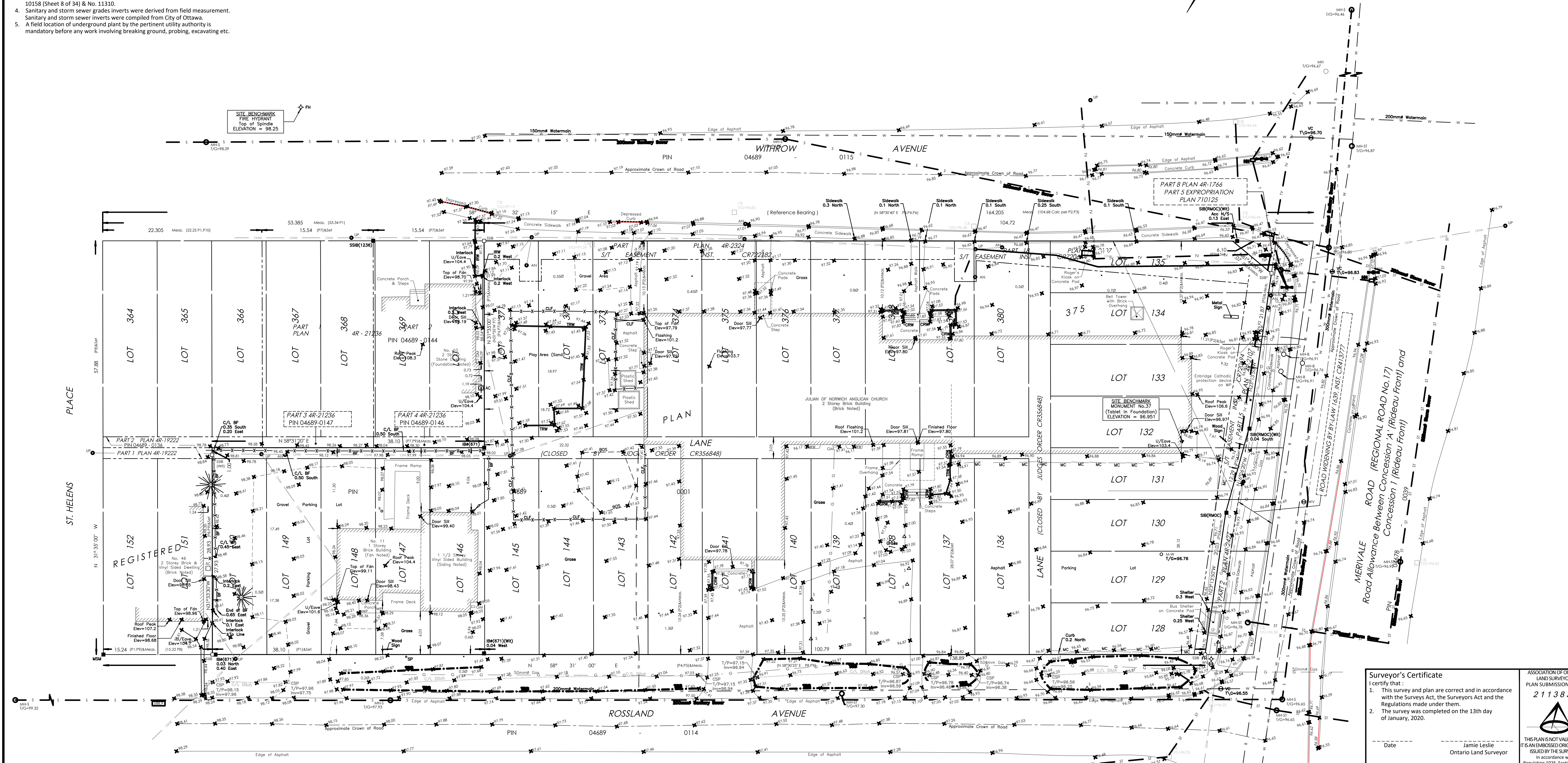
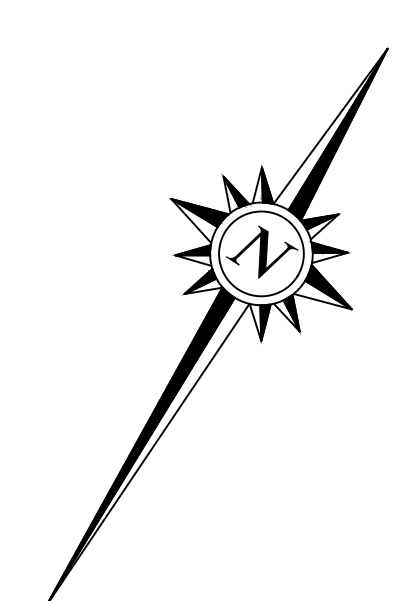

TOPOGRAPHIC DATA WAS COLLECTED UNDER WINTER CONDITIONS. SNOW COVER AND ICE PRECLUDE DETERMINING LOCATION AND ELEVATION OF SOME TOPOGRAPHICAL DATA THAT IS OTHERWISE VISIBLE.
WARNING: NO PERSON MAY COPY, REPRODUCE, DISTRIBUTE OR ALTER THIS PLAN IN WHOLE OR IN PART WITHOUT THE WRITTEN PERMISSION OF FARLEY, SMITH & DENIS SURVEYING LTD.

Surveyor's Certificate
I certify that:
1. This survey and plan are correct and in accordance with the Survey Act, the Surveyors Act and the Regulations made under them.
2. The survey was completed on the 13th day of January, 2020.
Date: Jamie Leslie, Ontario Land Surveyor

FARLEY, SMITH & DENIS SURVEYING LTD
ONTARIO LAND SURVEYORS
CANADA LAND SURVEYORS
190 COLONNADE ROAD, OTTAWA, ONTARIO K2E 7J5
TEL. (613) 727-8226 FAX. (613) 727-1826
FILE No.: 653-19

### A.3 Pre-Consultation Meeting Minutes



## **Pre-Application Consultation Meeting Notes**

**Property Address:** 7 Rossland

PC2023-0007

January 24, Microsoft Teams

### **Attendees:**

Lisa Stern, Planner III (File Lead)

Alex Gatien, Planner I

Selma Hassan, Urban Design

Neeti Paudel, Transportation Project Manager

Shika Rathnasooriya, Infrastructure Project Manager

Nancy Young, Forester

Gabrielle Schaeffer, Infrastructure Project Manager

Eric Bays, Stantec

Aditi Mane, Stantec

Melissa Du Plessis, Project Architect – Figurr Architects

Roberto Campos, Architect – Figurr Architects

Monique Stone, Julian of Norwich Anglican Church

Suzanne Le, Multi-faith Housing Initiative

**Regrets:** Louise Cervený, Parks Planning

**Subject:** 7 Rossland Proposed Redevelopment

### **Meeting notes:**

#### **Overview of proposal:**

- The current church building is nearing the end of its life. Intention is to integrate congregation in redeveloping the site to include affordable housing.
- Will require a rezoning and site plan, likely in subsequent applications. Potential for phased approach to construction depending on funding availability.
- Intention is to integrate mid-rise apartments, stacked townhouses and the church into one development.
- The intention is to partner with an affordable housing provider to construct the residential component of the development.
- Currently in the final stages of approval for a cemetery removal permit with the Province.
- Have revised the application from the previous concept to remove underground parking to ensure that the affordable housing component is viable.
- Details: 8-storey apartment building on Merivale with the church integrated into the ground floor. The proposed building would share some facilities between residents and the church. There will be multiple entrances to the residential building.

- Parking off of Withrow would be shared and provide garbage removal for the apartment building with 21 spaces
- Withrow stacked towns would be oriented north-south. Combination of two-storey townhouses and single-storey units with one bedroom. Total of 24 units.
- Rossland accessed parking would include 36 parking spaces.
- Preservation of large oak tree if possible.
- Rossland townhouses would be similar in layout, except they would have their own driveways, rather than a parking lot.
- Number of units will likely be 88. To be confirmed.
- Property is split between Institutional and Institutional with a site-specific exception that permits a group home. Front of the property is AM10. Potential to zone entire property AM10 or back to R3.
- Applicant is expecting a delay between ZBA and SPC application. Would like to ensure no duplication of studies.

Preliminary comments and questions from staff and agencies, including follow-up actions:

**Planning (lisa.stern@ottawa.ca)**

- A Major Rezoning Application will be required to facilitate the proposed development.
- The site is designated Major Corridor and neighbourhood in the Outer Urban Transect of the Official Plan. Please take note of the Area Specific Policies in the Official Plan relating to this section of Merivale Road. Of note is no direct accesses onto Merivale and there shall be a 7m setback from the edge of the road to the building.
- AM10 with an exception to identify heights would be preferred. Stacked towns could also be R3 or R4. Must ensure transition from surrounding neighbourhood is addressed through an exception or zoning schedule
- Given the low-density context to the west and on the north side of Withrow Avenue, the use of setbacks and transition in the proposed heights is important to ensure the proposal and associated massing are compatible.
- Please ensure that setbacks on Rossland and Withrow are sufficient to ensure that the rural cross section can be maintained and that there is ample space for tree planting and sidewalks.
- It would be preferred to see a built form that addresses Withrow. Please consider rotating the stacked dwellings 90 degrees to maintain a consistent street wall along Withrow, more along the lines of the previous proposal.
- A more detailed site plan would be appreciated as it is difficult to appreciate the programming of the central amenity space.
- It appears that a significant reduction in parking is proposed to support the development, a reduced rate for the residential and no on-site parking for the institutional uses is proposed. Please provide a Parking Impact Assessment which rationalizes parking rates based on the following:
  - Merivale has bus service, but it is not identified for rapid transit.
  - Church and community uses would likely be busy at the same time as resident parking.

- Please provide a description of the 'multi-purpose' room use, will this be for the sole use of the Place of Worship and residents on Site or will it be open to the wider community? This may be an ancillary community centre use rather an accessory to the place of worship, meaning that it may require its own parking for the use.
- Please assess parking rates associated with existing affordable housing project to rationalize a lower parking rates.
- Please examine TDM measures such as providing car share or bus passes for residents.
- Please examine the possibility of formalizing shared off-site parking for the Place of Worship.

### **Urban Design (Selma.Hassan@ottawa.ca)**

1. The site is on a Mainstreet Corridor in a Design Priority Area. As such, applications for the site are required to go before the City's Urban Design Review Panel.
2. A Design Brief is required. A Terms of Reference for the Brief is attached. All elements highlighted in yellow must be addressed.
3. A Type 2 Wind Study will be requested when the applicant submits a Site Plan Control application.
4. The existing mature Maple trees on Withrow contribute significantly to the streetscape. Their locations need to be shown on future drawings and development (both parking areas and buildings) should be shifted south to preserve them. Please indicate the extents of the critical root zones on the drawings
5. Similarly, the mature Oak tree on Rossland should be preserved within the design; please indicate the extents of the critical root zone on the drawings.
6. The north-south orientation of the Withrow stacks does not address the street. The previous concept had the primary façade parallel and responding to the street. The large surface parking areas adjacent to Withrow are not desirable. The applicant is asked to re-explore alternate layouts for the parking and building that provide an east-west building orientation and that reduce the amount of surface parking visible from the street.
7. Please provide a conceptual landscape plan which shows future planting - new trees, buffering of any remaining surface parking that is visible from the street and buffering to adjacent residential.
8. On future drawings, please:
  - a. clearly distinguish hard and soft surface areas
  - b. show the locations of all internal walkways and service areas
  - c. show the garbage / recycling bin storage solution for the stacks, on future drawings. Will there be a separate garbage enclosure?
  - d. identify where residents will store bicycles
  - e. show a sidewalk on Rossland

### **Trees and Forestry (Nancy.young@ottawa.ca)**

- A Tree Conservation Report is required with the Rezoning application, in accordance with the requirements listed below.
- There are several significant trees on site which are providing a great deal of value to the community, both ecologically and aesthetically. The new Official Plan strongly supports both intensification and retention of existing trees as well as providing space to plant new trees.
- The TCR will need to provide details on all of the trees, but should help to prioritize the ones to design around, based on their health, condition, and significance. Several that stand out as necessary to retain are the oak tree on Rossland (identified by the community) and the City trees in front of 11 Rossland. Efforts must be made to retain at least a few of the trees along Withrow by incorporating them into the design for the site. These are highlighted on the snip below.
  - The proposed park/community space is an excellent feature for the site; it is strongly recommended to arrange this space to maximise the retention of existing trees.
  - One particular item to note is that the proposed location of the drop off area from Rossland, will impact the large maple tree within the multi-purpose community space. It is strongly recommended to shift the drop off location to avoid impacting this tree.



○

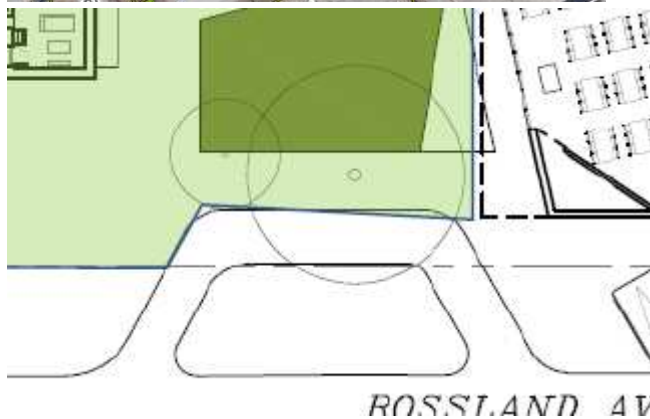

- The Landscape Plan must show where the replacement trees will be planted, with a priority of planting large-growing native species within or close to the ROW, to improve the future streetscape and canopy cover.
  - As noted in the meeting, under the Merivale Rd Special Policy, it is strongly recommended to plant trees along Merivale, to improve the streetscape and pedestrian experience.

### **Engineering (Thakshika.Rathnasooriya@ottawa.ca)**

1. The Servicing Study Guidelines for Development Applications are available at the following address: <http://ottawa.ca/en/development-application-review-process-0/servicing-study-guidelines-development-applications>
2. Servicing and site works shall be in accordance with the following documents:
  - ⇒ Ottawa Sewer Design Guidelines (October 2012)
  - ⇒ Ottawa Design Guidelines – Water Distribution (2010)
  - ⇒ Geotechnical Investigation and Reporting Guidelines for Development Applications in the City of Ottawa (2007)
  - ⇒ City of Ottawa Slope Stability Guidelines for Development Applications (revised 2012)
  - ⇒ City of Ottawa Environmental Noise Control Guidelines (January, 2016)
  - ⇒ City of Ottawa Park and Pathway Development Manual (2012)
  - ⇒ City of Ottawa Accessibility Design Standards (2012)
  - ⇒ Ottawa Standard Tender Documents (latest version)
  - ⇒ Ontario Provincial Standards for Roads & Public Works (2013)
3. Record drawings and utility plans are also available for purchase from the City (Contact the City's Information Centre by email at [InformationCentre@ottawa.ca](mailto:InformationCentre@ottawa.ca) or by phone at (613) 580-2424 x.44455).
4. Since the City View area has significant storm water management issues and this is a highly urbanized site, a storm sewer from Merivale must be extended as an outlet for the site. There is a 375mm stub on Withrow Avenue and a 300mm stub on Rossland Avenue.
5. Storm Criteria to be followed for the site:
  - a. The site's post development release rate, up to the 100 year storm event, must be controlled to the site's pre-development 2 year storm event release rate.
  - b. Runoff coefficient (C):  $C=0.5$  or  $C=\text{pre-development}$ , whichever is less.
  - c. Time of concentration (Tc): To be calculated, min Tc=10mins
  - d. MVCA to provide criteria related to quality control criteria.
  - e. Ditches in the City View area will be reopened within the next 10 years, with Withrow Avenue and Rossland Avenue occurring within 2-5 years.
  - f. Extend the storm sewer from Merivale Road to the proposed site as outlet.



6. Sanitary:
  - a. 200mm AC sewer on Rossland Avenue, 200mm AC sewer on Withrow Avenue.
  - b. A monitoring manhole is required to be installed on private property.
7. Water:
  - a. 152mm CI watermain on Withrow Avenue, 203 mm CI watermain on Rossland Avenue.
  - b. The two roads are in different pressure zones. With Withrow Avenue having a higher HGL and therefore may have limited availability. Preferred to connect to Rossland Avenue.
  - c. Only one water connection can be made either on Withrow Avenue or on Rossland Avenue, but not both streets. This is due to both roads fronting different water pressure zones.
  - d. Water service redundancy (two connections to the public water main with isolation valve in between) will need to be provided for any building or site where there is greater than 49 dwelling units and/or 50m<sup>3</sup>/day of basic day demand.
  - e. Water Boundary condition requests must include the location of the service(s) and the expected loads required by the proposed development. Please provide the following information:
    1. Location of service
    2. Type of development and the amount of fire flow required (as per FUS, 1999).
    3. Average daily demand: \_\_\_ l/s.
    4. Maximum daily demand: \_\_\_ l/s.
    5. Maximum hourly daily demand: \_\_\_ l/s.
  - i. From a servicing perspective, the site should be treated as one site with single sanitary and storm connections. All buildings should obtain servicing from within the site itself. A perimeter metering chamber should be installed for the water service (one City water meter for site) and each building can be privately sub-metered.
  - ii. A monitoring maintenance hole shall be required just inside the property line for the site's sanitary service. The maintenance hole should be located in an accessible location on private property near the property line (ie. Not in a parking area).
8. MECP ECA Requirements

Note that an MECP Environmental Compliance Approval (Private Sewage Works) will be required for the proposed development if the stormwater management plan for the site results in flows (major or minor) that cross any shared property line. ECA requirements can be further assessed once a formal application is received.

9. Phase 1 ESAs and Phase 2 ESAs must conform to clause 4.8.4 of the Official Plan that requires that development applications conform to Ontario Regulation 153/04.

### **Transportation (Neeti.paudel@ottawa.ca)**

1. Follow Traffic Impact Assessment Guidelines
2. Angled parking on Rossland Avenue (City right of way) will not be supported.
3. ROW protection on Merivale between Baseline and West Hunt Club is 44.5 (22.25 m from centerline) metres even.
4. ROW protection on Withrow between Meadowlands and Merivale is 24 metres even.
5. Consider relocating the access further west on Withrow. Minimum required clearance from the intersection is 55m. TIA will not be required in this case.
6. There is a bus stop on Merivale along the site frontage. Provide clear/ direct connections from the site to the bus stop. Recommend providing sidewalk along the Rossland.
7. Site triangles at the following locations on the final plan will be required:
  - a. Collector Road to Arterial Road: 5 metre x 5 metres
  - b. Local Road to Arterial Road: 5 metre x 5 metres
8. Noise Impact Studies required for the following:
  - a. Road
  - b. Stationary (if there will be any exposed mechanical equipment due to the proximity to neighbouring noise sensitive land uses)
9. Ensure throat length requirements for the access are met as per TAC guidelines (15m for collector).
10. On site plan:
  - a. Show all details of the roads abutting the site up to and including the opposite curb; include such items as pavement markings, accesses and/or sidewalks.
  - b. Turning templates will be required for all accesses showing the largest vehicle to access the site; required for internal movements and at all access (entering and exiting and going in both directions).
  - c. Show all curb radii measurements; ensure that all curb radii are reduced as much as possible
  - d. Show lane/aisle widths.
  - e. Sidewalk is to be continuous across access as per City Specification 7.1.
11. AODA legislation applies to all areas accessible to public.
  - a. Clearly define accessible parking stalls and ensure they meet AODA standards (include an access aisle next to the parking stall and a pedestrian curb ramp at the end of the access aisle, as required).
  - b. Please consider using the City's Accessibility Design Standards, which provide a summary of AODA requirements. <https://ottawa.ca/en/city-hall/creating-equal-inclusive-and-diverse-city/accessibility-services/accessibility-design-standards-features#accessibility-design-standards>

### **Submission requirements and fees**

- Additional information regarding fees related to planning applications can be found [here](#).

- Plans are to be standard A1 size (594 mm x 841 mm) or Arch D size (609.6 mm x 914.4 mm) sheets, dimensioned in metric and utilizing an appropriate Metric scale (1:200, 1:250, 1:300, 1:400 or 1:500).
- All PDF submitted documents are to be unlocked and flattened.

### **Next steps**

- Please discuss the proposal with Councillor, community groups and neighbours
- As a result of the More Homes for Everyone Act, 2022, it is anticipated that new pre-application consultation processes will be in place as of July 1, 2023, for site plan approval and zoning by-law amendments applications. The new processes are anticipated to require a multiple phase pre-application consultation approach before an application will be deemed complete. Applicants who have not filed a complete application by the effective date may be required to undertake further pre-application consultation(s) consistent with the provincial changes. The by-laws to be amended include By-law 2009-320, the Pre-Consultation By-law, By-law 2022-239, the planning fees by-law and By-law 2022-254, the Information and Materials for Planning Application By-law. The revisions are anticipated to be before Council in the coming months.

## Appendix B Water Servicing

### B.1 Domestic Water Demands



## 8 Withrow Avenue - Domestic Water Demand Estimates

Site Plan provided by Figurr Architects Ltd. (2023-06-30)  
Project Number: 160401691

Population densities as per Ottawa Design Guidelines - Water Distribution <sup>3</sup>		
Studio/1 Bedroom	1.4	ppu
2 Bedroom	2.1	ppu
3 Bedroom	3.1	ppu
Townhouses	2.7	ppu



Demand conversion factors as per MECP Guidelines and Ottawa Design Guidelines - Water Distribution <sup>3</sup>		
Residential	280	L/cap/day
Institutional	28000	L/gross ha/day

Building ID	Area (ha)	Studio	1 Bedroom	2 Bedroom	3 Bedroom	Townhouse	Population	Avg. Day Demand		Max. Day Demand <sup>2</sup>		Peak Hour Demand <sup>1</sup>	
								(L/min)	(L/s)	(L/min)	(L/s)	(L/min)	(L/s)
Church	0.04							0.7	0.01	1.1	0.02	1.96	0.03
<b>Institutional Total</b>	<b>0.04</b>							<b>0.7</b>	<b>0.01</b>	<b>1.1</b>	<b>0.02</b>	<b>1.96</b>	<b>0.03</b>
<b>Stacked &amp; Back-to-Back Townhouses <sup>5</sup></b>						27	73	14.2	0.24	35.4	0.59	78.0	1.30
Apartment <sup>5</sup>		1	22	20	14		118	22.9	0.38	57.2	0.95	125.8	2.10
<b>Residential Total</b>			<b>22</b>	<b>20</b>	<b>14</b>	<b>27</b>	<b>191</b>	<b>37.0</b>	<b>0.62</b>	<b>92.6</b>	<b>1.54</b>	<b>203.7</b>	<b>3.40</b>
<b>Total Site :</b>		<b>1</b>	<b>22</b>	<b>20</b>	<b>14</b>	<b>27</b>	<b>191</b>	<b>37.8</b>	<b>0.63</b>	<b>93.7</b>	<b>1.56</b>	<b>205.7</b>	<b>3.43</b>

**Notes:**

- Water demand criteria used to estimate peak demand rates for residential areas are as follows from City of Ottawa Water Design Guidelines Table 4.2:  
maximum day demand rate = 2.5 x average day demand rate  
peak hour demand rate = 2.2 x maximum day demand rate (as per Technical Bulletin ISD-2010-02)
- Water demand criteria used to estimate peak demand rates for institutional areas are as follows from City of Ottawa Water Design Guidelines Table 4.2:  
maximum day demand rate = 1.5 x average day demand rate  
peak hour demand rate = 1.8 x maximum day demand rate (as per Technical Bulletin ISD-2010-02)
- Population Densities provided on Table 4.1 Per Unit Populations from the City of Ottawa Water Design Guidelines (2010)
- As per Table 4.2 from the City of Ottawa Water Design Guidelines and Technical Bulletin ISTB-2021-03, the average daily rate of water demand for residential areas: 280 L/cap/day
- Site unit counts provided in correspondence with Architect (2023-04-25) and from Site Plan provided by Figurr Architects Ltd. (2023-06-30)

## B.2 Fire Flow Demands (2020 FUS)





FUS Fire Flow Calculation Sheet - 2020 FUS Guidelines

Stantec Project #: 160401691  
 Project Name: The Anchor (8 Withrow and 7 Rossland)  
 Date: 6/7/2023

Designed by: MW  
 Checked by:  
 Revision No.:

Fire Flow Calculation #: 1  
 Description: 12 x 3-Storey Stacked Townhouses with Basement

Notes: Site plan provided by Figurr Architects Ltd. on 2023-06-30. Ground floor footprint at 567 m<sup>2</sup>.

Step	Task	Notes						Value Used	Req'd Fire Flow (L/min)	
1	Determine Type of Construction	Type V - Wood Frame / Type IV-D - Mass Timber Construction						1.5	-	
2	Determine Effective Floor Area	Sum of All Floor Areas						NO	-	
		567	567	567				1701	-	
3	Determine Required Fire Flow	(F = 220 x C x A <sup>1/2</sup> ). Round to nearest 1000 L/min						-	14000	
4	Determine Occupancy Charge	Limited Combustible						-15%	11900	
5	Determine Sprinkler Reduction	Conforms to NFPA 13						-30%	-4760	
		Standard Water Supply						-10%		
		Not Fully Supervised or N/A						0%		
		% Coverage of Sprinkler System						100%		
6	Determine Increase for Exposures (Max. 75%)	Direction	Exposure Distance (m)	Exposed Length (m)	Exposed Height (Stories)	Length-Height Factor (m x stories)	Construction of Adjacent Wall	Firewall / Sprinklered ?	-	-
		North	> 30	0	0	0-20	Type V	NO	0%	1904
		East	> 30	0	0	0-20	Type V	NO	0%	
		South	> 30	0	0	0-20	Type V	NO	0%	
		West	3.1 to 10	13	2	21-49	Type V	NO	16%	
7	Determine Final Required Fire Flow	Total Required Fire Flow in L/min, Rounded to Nearest 1000L/min							9000	
		Total Required Fire Flow in L/s							150.0	
		Required Duration of Fire Flow (hrs)							2.00	
		Required Volume of Fire Flow (m <sup>3</sup> )							1080	



FUS Fire Flow Calculation Sheet - 2020 FUS Guidelines

Stantec Project #: 160401691  
 Project Name: The Anchor (8 Withrow and 7 Rossland)  
 Date: 5/2/2023

Fire Flow Calculation #: 2  
 Description: 15 x 3-Storey Stacked Townhouses with Basement

Notes: Site plan provided by Figurr Architects Ltd. on 2023-06-30. Ground floor footprint at 497 m<sup>2</sup>.

Step	Task	Notes						Value Used	Req'd Fire Flow (L/min)
1	Determine Type of Construction	Type V - Wood Frame / Type IV-D - Mass Timber Construction						1.5	-
2	Determine Effective Floor Area	Sum of All Floor Areas						NO	-
		497	497	497				1491	-
3	Determine Required Fire Flow	(F = 220 x C x A <sup>1/2</sup> ). Round to nearest 1000 L/min						-	13000
4	Determine Occupancy Charge	Limited Combustible						-15%	11050
5	Determine Sprinkler Reduction	Conforms to NFPA 13						-30%	-4420
		Standard Water Supply						-10%	
		Not Fully Supervised or N/A						0%	
		% Coverage of Sprinkler System						100%	
6	Determine Increase for Exposures (Max. 75%)	Direction	Exposure Distance (m)	Exposed Length (m)	Exposed Height (Stories)	Length-Height Factor (m x stories)	Construction of Adjacent Wall	Firewall / Sprinklered ?	-
		North	10.1 to 20	35	2	61-80	Type V	NO	13%
		East	> 30	0	0	0-20	Type V	NO	0%
		South	> 30	0	0	0-20	Type V	NO	0%
		West	0 to 3	14.9	2	21-49	Type V	NO	21%
7	Determine Final Required Fire Flow	Total Required Fire Flow in L/min, Rounded to Nearest 1000L/min							10000
		Total Required Fire Flow in L/s							166.7
		Required Duration of Fire Flow (hrs)							2.00
		Required Volume of Fire Flow (m <sup>3</sup> )							1200





FUS Fire Flow Calculation Sheet - 2020 FUS Guidelines

Stantec Project #: 160401691  
 Project Name: The Anchor (8 Withrow and 7 Rossland)  
 Date: 5/2/2023  
 Fire Flow Calculation #: 3  
 Description: 8-Storey Apartment and Church

Notes: Site plan provided by Figurr Architects Ltd. on 2023-03-28. Ground floor footprint at 1158 m<sup>2</sup>, upper floors with overhangs at 799 m<sup>2</sup> each.

Step	Task	Notes										Value Used	Req'd Fire Flow (L/min)
1	Determine Type of Construction	Type III - Ordinary Construction / Type IV-C - Mass Timber Construction										1	-
2	Determine Effective Floor Area	Sum of All Floor Areas										-	-
		1158	799	799	799	799	799	799	799	799	799	6748	-
3	Determine Required Fire Flow	(F = 220 x C x A <sup>1/2</sup> ). Round to nearest 1000 L/min										-	18000
4	Determine Occupancy Charge	Limited Combustible										-15%	15300
5	Determine Sprinkler Reduction	Conforms to NFPA 13										-30%	-7650
		Standard Water Supply										-10%	
		Fully Supervised										-10%	
		% Coverage of Sprinkler System										100%	
6	Determine Increase for Exposures (Max. 75%)	Direction	Exposure Distance (m)	Exposed Length (m)	Exposed Height (Stories)	Length-Height Factor (m x stories)	Construction of Adjacent Wall	Firewall / Sprinklered ?				-	-
		North	> 30	0	0	0-20	Type V	NO				0%	0
		East	> 30	0	0	0-20	Type V	NO				0%	
		South	> 30	0	0	0-20	Type V	NO				0%	
		West	> 30	0	0	0-20	Type V	NO				0%	
7	Determine Final Required Fire Flow	Total Required Fire Flow in L/min, Rounded to Nearest 1000L/min											8000
		Total Required Fire Flow in L/s											133.3
		Required Duration of Fire Flow (hrs)											2.00
		Required Volume of Fire Flow (m <sup>3</sup> )											960

### **B.3 Boundary Conditions (City of Ottawa)**



## Wu, Michael

---

**From:** Rathnasooriya, Shika <Thakshika.Rathnasooriya@ottawa.ca>  
**Sent:** July 24, 2023 12:16  
**To:** Wu, Michael  
**Cc:** Gladish, Alyssa; Mott, Peter  
**Subject:** RE: The Anchor (8 Withrow Avenue and 7 Rossland Avenue) Boundary Condition Request  
**Attachments:** 7 Rossland Avenue REVISED June 2023.pdf

Hi Michael,

Sorry for the delay, it just came in.

The following are boundary conditions, HGL, for hydraulic analysis at 8 Withrow and 7 Rossland (zone 2W2C) assumed to be a dual connection to the 203 mm watermain on Rossland Avenue **OR** dual connection to the 152 mm watermain on Withrow Avenue (zone ME). See attached PDF for location.

	203 mm on Rossland <b>Option 1</b>	152 mm on Withrow <b>Option 2</b>
	Zone: 2W2C	Zone: ME
Min HGL (m)	125.4	147.4
Max HGL (m)	133.3	156.2
Max Day + FF (167 L/s)	118.9	123.4

These are for current conditions and are based on computer model simulation.

*Disclaimer: The boundary condition information is based on current operation of the city water distribution system. The computer model simulation is based on the best information available at the time. The operation of the water distribution system can change on a regular basis, resulting in a variation in boundary conditions. The physical properties of watermains deteriorate over time, as such must be assumed in the absence of actual field test data. The variation in physical watermain properties can therefore alter the results of the computer model simulation.*

Thanks,  
Shika

---

**From:** Wu, Michael <Michael.Wu@stantec.com>  
**Sent:** July 11, 2023 8:31 AM  
**To:** Rathnasooriya, Shika <Thakshika.Rathnasooriya@ottawa.ca>  
**Cc:** Gladish, Alyssa <Alyssa.Gladish@stantec.com>; Mott, Peter <Peter.Mott@stantec.com>  
**Subject:** RE: The Anchor (8 Withrow Avenue and 7 Rossland Avenue) Boundary Condition Request

**CAUTION: This email originated from an External Sender. Please do not click links or open attachments unless you recognize the source.**

**ATTENTION : Ce courriel provient d'un expéditeur externe. Ne cliquez sur aucun lien et n'ouvrez pas de pièce jointe, excepté si vous connaissez l'expéditeur.**

Good morning, Shika:

Just want to follow-up and see if you could provide the revised boundary conditions for the site.

Thanks,

**Michael Wu** EIT  
Civil Engineering Intern, Community Development

Direct: 1 (613) 738-6033  
Michael.Wu@stantec.com

Stantec  
300-1331 Clyde Avenue  
Ottawa ON K2C 3G4



The content of this email is the confidential property of Stantec and should not be copied, modified, retransmitted, or used for any purpose except with Stantec's written authorization. If you are not the intended recipient, please delete all copies and notify us immediately.

---

**From:** Wu, Michael  
**Sent:** Wednesday, June 7, 2023 5:01 PM  
**To:** Rathnasooriya, Shika <Thakshika.Rathnasooriya@ottawa.ca>  
**Cc:** Gladish, Alyssa <Alyssa.Gladish@stantec.com>  
**Subject:** RE: The Anchor (8 Withrow Avenue and 7 Rossland Avenue) Boundary Condition Request

Good afternoon, Shika:

We would like to request revised hydraulic boundary conditions for the site.

As part of the revised boundary conditions request, we have updated the fire flow demands from the site, in which the two sets of townhouses will be sprinklered.

Therefore, the updated worst-case fire flow demand for the site is 166.7 L/s (10000 L/min) and attached is the updated FUS fire flow calculation sheet. The domestic water demands and locations remain unchanged from the initial request.

We appreciate your time looking into this for us, and please let us know if you have any questions or comments.

Thanks,

**Michael Wu, EIT**  
Civil Engineering Intern, Community Development

Work: (613) 738-6033  
Mobile: (613) 858-0548  
[michael.wu@stantec.com](mailto:michael.wu@stantec.com)

Stantec  
300 - 1331 Clyde Avenue  
Ottawa ON K2C 3G4

## B.4 Fire Hydrant Coverage Calculations



	Project:	Julian of Norwich - 8 Withrow Avenue and 7 Rossland Avenue		160401691
	<b>TABLE 1: FIRE HYDRANT COVERAGE TABLE</b>			
	Revision:	2	Prepared By:	MW
Revision Date:	10/26/2023	Checked By:	PM	

Description	Hydrants <sup>1</sup>					Total Available Fire Flow (L/min)	Total Required Fire Flow <sup>2</sup> (L/min)
	HYD-01: On-Site FH	HYD-02: Rossland West FH	HYD-03: Rossland East FH	HYD-04: Withrow East FH	HYD-05: Withrow West FH		
<b>15-Unit Townhouse, fronting Rossland</b>							
Distance from building (m)	35	35	121	-	-	-	-
Maximum fire flow capacity <sup>3</sup> (L/min)	5,678	5,678	3,785	-	-	<b>15,141</b>	10,000
<b>12-Unit Townhouse, fronting Withrow</b>							
Distance from building (m)	17	-	-	92	56	-	-
Maximum fire flow capacity <sup>3</sup> (L/min)	5,678	-	-	3,785	5,678	<b>15,141</b>	9,000
<b>8-Storey Apartment Building and Church</b>							
Distance from building (m)	61	133	19	37	-	-	-
Maximum fire flow capacity <sup>3</sup> (L/min)	5,678	3,785	5,678	5,678	-	<b>20,819</b>	8,000

NFPA 1 Table 18.5.4.3	
Distance to Building (m)	Maximum Capacity (L/min)
≤ 76	5,678
> 76 and ≤ 152	3,785
> 152 and ≤ 305	2,839

**Notes:**

- Hydrant locations as per GeoOttawa accessed June 12, 2023. Refer to fire hydrant coverage sketch (Figure 3-1).
- See FUS Calculations, Appendix A.2 for fire flow requirements.
- See NFPA 1 Table 18.5.4.3 (and Appendix I of ISTB-2018-02 Technical Bulletin) for maximum fire flow capacity of hydrants by distance to building.
- Hydrant distance (m) to Rossland Towns denoted by red line; to Withrow Towns denoted by blue line; and to Residential/Church Building by yellow line.

## B.5 Multi-Hydrant Hydraulic Analysis Request



## Gladish, Alyssa

---

**From:** Mott, Peter  
**Sent:** Thursday, October 26, 2023 12:54 PM  
**To:** eric.surprenant@ottawa.ca  
**Cc:** Gladish, Alyssa; colette.gorni@ottawa.ca  
**Subject:** 8 Withrow Avenue - Updated Boundary Conditions and  
**Attachments:** The Anchor BC Request Map.pdf; The Anchor Fire Exposures Sketch.pdf; Figure 3-1 Julian of Norwich - Fire Hydrant Coverage Map.pdf; 2023-10-26 8 Withrow Hydrant Coverage Table.pdf; 2023-10-26 8 Withrow FUS Fire Flow.pdf; The Anchor Water Demand.pdf; 160401691.DB.FS-SSP-1.pdf

**Follow Up Flag:** Follow up  
**Due By:** Tuesday, November 14, 2023 9:00 AM  
**Flag Status:** Completed

Good afternoon Eric,

We would like to request updated hydraulic boundary conditions and a multi hydrant hydraulic analysis for the proposed mixed-use and residential development on 8 Withrow Avenue and 7 Rossland Avenue, with the units and populations outlined in the attached Water Demand calculation sheet.

The proposed site is expected to be serviced via connections to the existing 203 mm diameter watermain on Rossland Avenue. Estimated domestic demands based on the City of Ottawa guidelines for the site are as follows:

- Domestic demands:
  - Average Day Demand: 0.64 L/s (38.1 L/min)
  - Maximum Day Demand: 1.57 L/s (94.45 L/min)
  - Peak Hour Demand: 3.46 L/s (207.33 L/min)

Per the 1<sup>st</sup> Review Engineering comments, we would also like to request a multi-hydrant hydraulic analysis. I have attached an updated Fire Hydrant Coverage Map with the associated Coverage Table, indicating the proposed FH hydrants and associated distances to be used.

The Fire Flow Demand scenarios have been outlined below:

1. Rossland – 3 Storey Stacked Town & Back-to-Back Units (15 Units): A fire flow requirement of 167.0 L/s (10000 L/min) will govern for the site considering HYD-01 (On-site), HYD-02, and HYD-03 as illustrated in the attached sketch.
2. Withrow – 3 Storey Stacked Town Units (12 Units): A fire flow requirement of 150.0 L/s (9000 L/min) for the building considering HYD-01 (On-site), HYD-04, and HYD-05 as illustrated in the attached sketch.
3. Eight Storey Mixed-Use Building: A fire flow requirement of 133.0 L/s (8000 L/min) ) for the building considering HYD-01 (On-site), HYD-02, HYD-03, and HYD-04 as illustrated in the attached sketch.

Attached are the boundary condition request map, 1<sup>st</sup> submissions site servicing plan (to demonstrate servicing layout), fire exposures sketch, and water demand and fire flow calculations for your information.

We appreciate your time looking into this for us, and for your awareness, I will be departing Stantec on October 27<sup>th</sup>, 2023. As such, please ensure all future communications are made with the PM, Alyssa Gladish.

Thanks,

**Peter Mott** EIT



Engineering Intern, Community Development

Mobile: +1 (613) 897-0445

Teams: +1 (613) 724-4370

Peter.Mott@stantec.com

Stantec

300 - 1331 Clyde Avenue

Ottawa ON K2C 3G4



The content of this email is the confidential property of Stantec and should not be copied, modified, retransmitted, or used for any purpose except with Stantec's written authorization. If you are not the intended recipient, please delete all copies and notify us immediately.

## Appendix C Sanitary

### C.1 Sanitary Sewer Design Sheet



	SUBDIVISION:	<h2 style="margin: 0;">SANITARY SEWER DESIGN SHEET</h2> <p style="margin: 0;">(City of Ottawa)</p>	DESIGN PARAMETERS											
	JULIAN OF NORWICH (8 Withrow Ave.)		MAX PEAK FACTOR (RES.)= 4.0	AVG. DAILY FLOW / PERSON 280 l/p/day	MINIMUM VELOCITY 0.60 m/s									
	DATE: 2023-07-12 REVISION: 1 DESIGNED BY: JP CHECKED BY: RB		MIN PEAK FACTOR (RES.)= 2.0 PEAKING FACTOR (INDUSTRIAL): 2.4 PEAKING FACTOR (ICI >20%): 1.5 PERSONS / SINGLE 3.4 PERSONS / TOWNHOME 2.7 PERSONS / APARTMENT 2.1 <sup>A</sup>	COMMERCIAL 28,000 l/ha/day INDUSTRIAL (HEAVY) 55,000 l/ha/day INDUSTRIAL (LIGHT) 35,000 l/ha/day INSTITUTIONAL 28,000 l/ha/day INFILTRATION 0.33 l/s/ha	MAXIMUM VELOCITY 3.00 m/s MANNINGS n 0.013 BEDDING CLASS B MINIMUM COVER 2.50 m HARMON CORRECTION FACTOR 0.8									
FILE NUMBER: 160401691														

LOCATION			RESIDENTIAL AREA AND POPULATION									COMMERCIAL		INDUSTRIAL (L)		INDUSTRIAL (H)		INSTITUTIONAL		GREEN / UNUSED		C+H	INFILTRATION <sup>B</sup>			TOTAL	PIPE								
AREA ID NUMBER	FROM M.H.	TO M.H.	AREA (ha)	SINGLE	UNITS TOWN	APT	POP.	CUMULATIVE AREA (ha)	CUMULATIVE POP.	PEAK FACT.	PEAK FLOW (l/s)	AREA (ha)	ACCU. AREA (ha)	AREA (ha)	ACCU. AREA (ha)	AREA (ha)	ACCU. AREA (ha)	AREA (ha)	ACCU. AREA (ha)	AREA (ha)	ACCU. AREA (ha)	PEAK FLOW (l/s)	TOTAL AREA (ha)	ACCU. AREA (ha)	INFILT. FLOW (l/s)	FLOW (l/s)	LENGTH (m)	DIA (mm)	MATERIAL	CLASS	SLOPE (%)	CAP. (FULL) (l/s)	CAP. V PEAK FLOW (%)	VEL. (FULL) (m/s)	
R2A	2	1	0.11	0	10	0	27	0.11	27	3.69	0.3	0.00	0.00	0.00	0.00	0.00	0.00	0.00	0.00	0.00	0.00	0.00	0.00	0.11	0.11	0.0	0.4	85.7	200	PVC	SDR 35	0.40	21.1	1.69%	0.67
G3AA	3A	3	0.13	0	0	57	118	0.13	118	3.58	1.4	0.00	0.00	0.00	0.00	0.00	0.00	0.10	0.10	0.13	0.13	0.05	0.36	0.36	0.1	1.5	25.6	150	PVC	DR 28	1.00	15.3	10.00%	0.86	
R4A	4	3	0.25	0	17	0	46	0.25	46	3.66	0.5	0.00	0.00	0.00	0.00	0.00	0.00	0.00	0.00	0.00	0.00	0.00	0.25	0.25	0.1	0.6	81.2	200	PVC	SDR 35	0.40	21.1	2.97%	0.67	
R3A	3	1	0.05	0	0	0	0	0.43	164	3.54	1.9	0.00	0.00	0.00	0.00	0.00	0.00	0.00	0.10	0.00	0.13	0.03	0.05	0.67	0.2	2.1	25.4	200	PVC	SDR 35	0.40	21.1	10.07%	0.67	
G1A	1	1A	0.06	0	0	0	0	0.60	191	3.52	2.176	0.00	0.00	0.00	0.00	0.00	0.00	0.00	0.10	0.06	0.20	0.03	0.12	0.90	0.30	2.5	6.0	200	PVC	SDR 35	0.40	21.1	11.85%	0.67	
							191																												

A. Apartment ppu averaged out based on number of units per correspondence with Architect (2023-04-25) and respective densities of each unit type

B. Entire site area considered for infiltration

APARTMENT STATS	UNITS	PPU		
STUDIO	1	1.4	1	0.4
1 BEDROOM	22	1.4	31	0.4
2 BEDROOM	20	2.1	42	0.2
3 BEDROOM	14	3.1	43	0.4
TOTAL	57		118	1.4
AVERAGE PPU		2.1		

## C.2 Correspondence with the City on Sanitary Sewer Capacity



**Mott, Peter**

---

**From:** Rathnasooriya, Shika <Thakshika.Rathnasooriya@ottawa.ca>  
**Sent:** Wednesday, May 31, 2023 10:32 AM  
**To:** Wu, Michael  
**Cc:** Gladish, Alyssa  
**Subject:** RE: 8 Withrow Avenue Sanitary Sewer Capacity Confirmation and SWM Quality Control Criteria

Hi Michael and Alyssa,

Not sure if I got back to you on the sanitary capacity but an additional 2.4L/s is negligible.

Thanks,  
Shika

---

**From:** Wu, Michael <Michael.Wu@stantec.com>  
**Sent:** May 17, 2023 2:22 PM  
**To:** Rathnasooriya, Shika <Thakshika.Rathnasooriya@ottawa.ca>  
**Cc:** Gladish, Alyssa <Alyssa.Gladish@stantec.com>  
**Subject:** 8 Withrow Avenue Sanitary Sewer Capacity Confirmation and SWM Quality Control Criteria

**CAUTION: This email originated from an External Sender. Please do not click links or open attachments unless you recognize the source.**

**ATTENTION : Ce courriel provient d'un expéditeur externe. Ne cliquez sur aucun lien et n'ouvrez pas de pièce jointe, excepté si vous connaissez l'expéditeur.**

Good afternoon, Shika:

In addition to the hydraulic boundary conditions, as part of the servicing for the proposed development on 8 Withrow Avenue and 7 Rossland Avenue, we would like to confirm if there is sufficient capacity downstream of the 200 mm diameter sanitary sewers in Withrow Avenue and Rossland Avenue and the 250 mm diameter sanitary sewer in Merivale Road to receive an additional peak flow of 2.4 L/s from the proposed development.

Please find our sanitary design sheet and location map attached for your information. Furthermore, it is my understanding that the City now provides the SWM quality control criteria. Are there any quality control measures applicable to the site?

On a side note, I will be away on vacation for two weeks starting this Friday afternoon. If you have any questions or have received the boundary conditions, please don't hesitate to reach out to Alyssa, who I have cc'd in this email.

Thanks,

**Michael Wu, EIT**  
Civil Engineering Intern, Community Development

Work: (613) 738-6033  
Mobile: (613) 858-0548  
[michael.wu@stantec.com](mailto:michael.wu@stantec.com)

Stantec  
300 - 1331 Clyde Avenue  
Ottawa ON K2C 3G4



The content of this email is the confidential property of Stantec and should not be copied, modified, retransmitted, or used for any purpose except with Stantec's written authorization. If you are not the intended recipient, please delete all copies and notify us immediately.

**Vacation Alert: I will be away on vacation from May 19<sup>th</sup> to June 2<sup>nd</sup>**

This e-mail originates from the City of Ottawa e-mail system. Any distribution, use or copying of this e-mail or the information it contains by other than the intended recipient(s) is unauthorized. Thank you.

Le présent courriel a été expédié par le système de courriels de la Ville d'Ottawa. Toute distribution, utilisation ou reproduction du courriel ou des renseignements qui s'y trouvent par une personne autre que son destinataire prévu est interdite. Je vous remercie de votre collaboration.

**Caution:** This email originated from outside of Stantec. Please take extra precaution.

**Attention:** Ce courriel provient de l'extérieur de Stantec. Veuillez prendre des précautions supplémentaires.

**Atención:** Este correo electrónico proviene de fuera de Stantec. Por favor, tome precauciones adicionales.

## Appendix D Stormwater Servicing

### D.1 Modified Rational Method Sheet



## Stormwater Management Calculations

File No: **160401691**  
 Project: **Julian of Norwich (8 Withrow Avenue and 7 Rossland Avenue)**  
 Date: **13-Nov-23**

SWM Approach:  
 Post-development to Pre-development flows

**Post-Development Site Conditions:**

**Overall Runoff Coefficient for Site and Sub-Catchment Areas**

Runoff Coefficient Table							
Catchment Type	Sub-catchment Area ID / Description	Area (ha) "A"	Runoff Coefficient "C"	"A x C"	Overall Runoff Coefficient		
Controlled - Tributary	UNDERGROUND STORAGE (UG)	Hard	0.435	0.9	0.392		
		Soft	0.081	0.2	0.016		
Subtotal			0.516		0.40772	0.790	
Controlled - Tributary to UGS	SITE-1	Hard	0.355	0.9	0.320		
		Soft	0.081	0.2	0.016		
Subtotal			0.436		0.33572	0.770	
Roof - Tributary to UGS	ROOF-1	Hard	0.080	0.9	0.072		
		Soft	0.000	0.2	0.000		
Subtotal			0.08		0.072	0.900	
Uncontrolled - Non-Tributary	UNC-1	Hard	0.038	0.9	0.034		
		Soft	0.042	0.2	0.008		
Subtotal			0.08		0.0424	0.530	
Uncontrolled - Non-Tributary	UNC-2	Hard	0.058	0.9	0.053		
		Soft	0.066	0.2	0.013		
Subtotal			0.124		0.06572	0.530	
<b>Total</b>			<b>0.720</b>		<b>0.516</b>	<b>0.72</b>	
<b>Overall Runoff Coefficient= C:</b>							

Total Roof Areas (Controlled)	0.080 ha
Total Tributary Surface Areas (Controlled)	0.436 ha
Total Tributary Area to UGS	0.516 ha
Total Uncontrolled Areas (Non-Tributary)	0.204 ha
Total Site	0.720 ha



## Stormwater Management Calculations

Project #160401691, Julian of Norwich (8 Withrow Avenue and 7 Rossland Avenue)  
Modified Rational Method Calculators for Storage

<b>2 yr Intensity</b> City of Ottawa	$I = a/(t + b)^c$	<b>a =</b> 732.951	<b>t (min)</b>	<b>I (mm/hr)</b>
		<b>b =</b> 6.199	10	76.81
		<b>c =</b> 0.81	20	52.03
			30	40.04
			40	32.86
			50	28.04
			60	24.56
			70	21.91
			80	19.83
			90	18.14
			100	16.75
			110	15.57
			120	14.56

**2 YEAR Predevelopment Target Release for Entire Site**

**Subdrainage Area:** Predevelopment Tributary Area to Outlet  
**Area (ha):** 0.5160  
**C:** 0.50

Typical Time of Concentration

tc (min)	I (2 yr) (mm/hr)	Qtargret (L/s)
10	76.8	55.1

**2 YEAR Modified Rational Method for Portion of Site**

**Subdrainage Area:** UNDERGROUND STORAGE Controlled - Tributary  
**Area (ha):** 0.52  
**C:** 0.79

tc (min)	I (2 yr) (mm/hr)	Qactual (L/s)	Qrelease (L/s)	Qstored (L/s)	Vstored (m <sup>3</sup> )
10	76.8	102.4	55.1	47.3	28.4
20	52.0	69.4	55.1	14.3	17.2
30	40.0	53.4	53.4	0.0	0.0
40	32.9	43.8	43.8	0.0	0.0
50	28.0	37.4	37.4	0.0	0.0
60	24.6	32.8	32.8	0.0	0.0
70	21.9	29.2	29.2	0.0	0.0
80	19.8	26.4	26.4	0.0	0.0
90	18.1	24.2	24.2	0.0	0.0
100	16.7	22.3	22.3	0.0	0.0
110	15.6	20.8	20.8	0.0	0.0
120	14.6	19.4	19.4	0.0	0.0

Stage	Head (m)	Discharge (L/s)	Vreq (cu. m)	Vavail (cu. m)	Volume Check
2-year Water Level	-	55.1	28.4	134	OK

**Subdrainage Area:** SITE-1 Controlled - Tributary to UGS  
**Area (ha):** 0.44  
**C:** 0.77

tc (min)	I (2 yr) (mm/hr)	Qactual (L/s)	Qrelease (L/s)	Qstored (L/s)	Vstored (m <sup>3</sup> )
10	76.8	87.1	87.1	0.0	0.0
20	52.0	59.0	59.0	0.0	0.0
30	40.0	45.4	45.4	0.0	0.0
40	32.9	37.3	37.3	0.0	0.0
50	28.0	31.8	31.8	0.0	0.0
60	24.6	27.8	27.8	0.0	0.0
70	21.9	24.8	24.8	0.0	0.0
80	19.8	22.5	22.5	0.0	0.0
90	18.1	20.6	20.6	0.0	0.0
100	16.7	19.0	19.0	0.0	0.0
110	15.6	17.6	17.6	0.0	0.0
120	14.6	16.5	16.5	0.0	0.0

**Subdrainage Area:** ROOF-1 Roof - Tributary to UGS  
**Area (ha):** 0.08  
**C:** 0.90

tc (min)	I (2 yr) (mm/hr)	Qactual (L/s)	Qrelease (L/s)	Qstored (L/s)	Vstored (m <sup>3</sup> )	Depth (mm)
10	76.81	15.37	15.37			
20	52.03	10.41	10.41			
30	40.04	8.02	8.02			
40	32.86	6.58	6.58			
50	28.04	5.61	5.61			
60	24.56	4.92	4.92			
70	21.91	4.39	4.39			
80	19.83	3.97	3.97			
90	18.14	3.63	3.63			
100	16.75	3.35	3.35			
110	15.57	3.12	3.12			
120	14.56	2.91	2.91			

**Subdrainage Area:** UNC-1 Uncontrolled - Non-Tributary  
**Area (ha):** 0.08  
**C:** 0.53

tc (min)	I (2 yr) (mm/hr)	Qactual (L/s)	Qrelease (L/s)	Qstored (L/s)	Vstored (m <sup>3</sup> )
10	76.81	9.05	9.05		
20	52.03	6.13	6.13		
30	40.04	4.72	4.72		
40	32.86	3.87	3.87		
50	28.04	3.31	3.31		
60	24.56	2.89	2.89		
70	21.91	2.58	2.58		
80	19.83	2.34	2.34		

Project #160401691, Julian of Norwich (8 Withrow Avenue and 7 Rossland Avenue)  
Modified Rational Method Calculators for Storage

<b>100 yr Intensity</b> City of Ottawa	$I = a/(t + b)^c$	<b>a =</b> 1735.688	<b>t (min)</b>	<b>I (mm/hr)</b>
		<b>b =</b> 6.014	10	178.56
		<b>c =</b> 0.820	20	119.95
			30	91.87
			40	75.15
			50	63.95
			60	55.89
			70	49.79
			80	44.99
			90	41.11
			100	37.90
			110	35.20
			120	32.89

**100 YEAR Predevelopment Target Release for Entire Site**

**Subdrainage Area:** Predevelopment Tributary Area to Outlet  
**Area (ha):** 0.5160  
**C:** 0.50

Estimated Time of Concentration after Development

tc (min)	I (100 yr) (mm/hr)	Q100yr (L/s)
10	178.6	128.1

**100 YEAR Modified Rational Method for Portion of Site**

**Subdrainage Area:** UNDERGROUND STORAGE (UGS) Controlled - Tributary  
**Area (ha):** 0.52  
**C:** 0.99

tc (min)	I (100 yr) (mm/hr)	Qactual (L/s)	Qrelease (L/s)	Qstored (L/s)	Vstored (m <sup>3</sup> )
10	178.6	248.0	55.1	192.9	115.8
20	120.0	166.6	55.1	111.5	133.8
30	91.9	127.6	55.1	72.5	130.5
40	75.1	104.4	55.1	49.3	118.3
50	64.0	88.8	55.1	33.7	101.2
60	55.9	77.6	55.1	22.6	81.2
70	49.8	69.2	55.1	14.1	59.1
80	45.0	62.5	55.1	7.4	35.5
90	41.1	57.1	55.1	2.0	10.9
100	37.9	52.6	52.6	0.0	0.0
110	35.2	48.9	48.9	0.0	0.0
120	32.9	45.7	45.7	0.0	0.0

Stage	Head (m)	Discharge (L/s)	Vreq (cu. m)	Vavail (cu. m)	Volume Check
100-year Water Level	-	55.1	133.8	134	OK

**Subdrainage Area:** SITE-1 Controlled - Tributary to UGS  
**Area (ha):** 0.44  
**C:** 0.96

tc (min)	I (100 yr) (mm/hr)	Qactual (L/s)	Qrelease (L/s)	Qstored (L/s)	Vstored (m <sup>3</sup> )
10	178.6	208.3	208.3	0.0	0.0
20	120.0	139.9	139.9	0.0	0.0
30	91.9	107.2	107.2	0.0	0.0
40	75.1	87.7	87.7	0.0	0.0
50	64.0	74.6	74.6	0.0	0.0
60	55.9	65.2	65.2	0.0	0.0
70	49.8	58.1	58.1	0.0	0.0
80	45.0	52.5	52.5	0.0	0.0
90	41.1	48.0	48.0	0.0	0.0
100	37.9	44.2	44.2	0.0	0.0
110	35.2	41.1	41.1	0.0	0.0
120	32.9	38.4	38.4	0.0	0.0

**Subdrainage Area:** ROOF-1 Roof - Tributary to UGS  
**Area (ha):** 0.08  
**C:** 1.00

tc (min)	I (100 yr) (mm/hr)	Qactual (L/s)	Qrelease (L/s)	Qstored (L/s)	Vstored (m <sup>3</sup> )	Depth (mm)
10	178.56	39.71	39.71			
20	119.95	26.68	26.68			
30	91.87	20.43	20.43			
40	75.15	16.71	16.71			
50	63.95	14.22	14.22			
60	55.89	12.43	12.43			
70	49.79	11.07	11.07			
80	44.99	10.01	10.01			
90	41.11	9.14	9.14			
100	37.90	8.43	8.43			
110	35.20	7.83	7.83			
120	32.89	7.32	7.32			

**Subdrainage Area:** UNC-1 Uncontrolled - Non-Tributary  
**Area (ha):** 0.08  
**C:** 0.66

tc (min)	I (100 yr) (mm/hr)	Qactual (L/s)	Qrelease (L/s)	Qstored (L/s)	Vstored (m <sup>3</sup> )
10	178.56	26.31	26.31		
20	119.95	17.67	17.67		
30	91.87	13.54	13.54		
40	75.15	11.07	11.07		
50	63.95	9.42	9.42		
60	55.89	8.24	8.24		
70	49.79	7.34	7.34		
80	44.99	6.63	6.63		

# Stormwater Management Calculations

**Project #160401691, Julian of Norwich (8 Withrow Avenue and 7 Rossland Avenue)  
Modified Rational Method Calculators for Storage**

	90	18.14	2.14	2.14		
	100	16.75	1.97	1.97		
	110	15.57	1.84	1.84		
	120	14.56	1.72	1.72		
Subdrainage Area: UNC-2 Uncontrolled - Non-Tributary						
Area (ha): 0.12						
C: 0.53						
	tc (min)	I (2 yr) (mm/hr)	Qactual (L/s)	Qrelease (L/s)	Qstored (L/s)	Vstored (m³)
	10	76.81	14.03	14.03		
	20	52.03	9.51	9.51		
	30	40.04	7.32	7.32		
	40	32.86	6.00	6.00		
	50	28.04	5.12	5.12		
	60	24.56	4.49	4.49		
	70	21.91	4.00	4.00		
	80	19.83	3.62	3.62		
	90	18.14	3.31	3.31		
	100	16.75	3.06	3.06		
	110	15.57	2.84	2.84		
	120	14.56	2.66	2.66		
SUMMARY TO OUTLET						
				Vrequired	Vavailable*	
	<b>Tributary Area</b>		0.516 ha			
	<b>Total 2yr Flow to Sewer</b>		55.1 L/s	28	134 m³	Ok
	<b>Non-Tributary Area</b>		0.204 ha			
	<b>Total 2yr Flow Uncontrolled</b>		23.1 L/s			
	<b>Total Area</b>		0.720 ha			
	<b>Total 2yr Flow Target</b>		78.2 L/s			
			55.1 L/s			

**Project #160401691, Julian of Norwich (8 Withrow Avenue and 7 Rossland Avenue)  
Modified Rational Method Calculators for Storage**

	90	41.11	6.06	6.06		
	100	37.90	5.58	5.58		
	110	35.20	5.19	5.19		
	120	32.89	4.85	4.85		
Subdrainage Area: UNC-2 Uncontrolled - Non-Tributary						
Area (ha): 0.12						
C: 0.66						
	tc (min)	I (100 yr) (mm/hr)	Qactual (L/s)	Qrelease (L/s)	Qstored (L/s)	Vstored (m³)
	10	178.56	40.78	40.78		
	20	119.95	27.39	27.39		
	30	91.87	20.98	20.98		
	40	75.15	17.16	17.16		
	50	63.95	14.61	14.61		
	60	55.89	12.77	12.77		
	70	49.79	11.37	11.37		
	80	44.99	10.27	10.27		
	90	41.11	9.39	9.39		
	100	37.90	8.66	8.66		
	110	35.20	8.04	8.04		
	120	32.89	7.51	7.51		
SUMMARY TO OUTLET						
				Vrequired	Vavailable*	
	<b>Tributary Area</b>		0.516 ha			
	<b>Total 100yr Flow to Sewer</b>		55.1 L/s	134	134 m³	Ok
	<b>Non-Tributary Area</b>		0.204 ha			
	<b>Total 100yr Flow Uncontrolled</b>		67.1 L/s			
	<b>Total Area</b>		0.720 ha			
	<b>Total 100yr Flow Target</b>		122.2 L/s			
			55.1 L/s			

## **D.2 Storm Sewer Design Sheet**





LOCATION		DRAINAGE AREA										PIPE SELECTION																												
AREA ID NUMBER	FROM M.H.	TO M.H.	AREA (2-YEAR)	AREA (5-YEAR)	AREA (10-YEAR)	AREA (100-YEAR)	AREA (ROOF)	C (2-YEAR)	C (5-YEAR)	C (10-YEAR)	C (100-YEAR)	A x C (2-YEAR)	ACCUM AxC (2YR)	A x C (5-YEAR)	ACCUM AxC (5YR)	A x C (10-YEAR)	ACCUM AxC (10YR)	A x C (100-YEAR)	ACCUM AxC (100YR)	T of C (min)	I <sub>2</sub> -YEAR (mm/h)	I <sub>5</sub> -YEAR (mm/h)	I <sub>10</sub> -YEAR (mm/h)	I <sub>100</sub> -YEAR (mm/h)	Q <sub>CONTROL</sub> (L/s)	ACCUM. Q <sub>CONTROL</sub> (L/s)	Q <sub>ACT</sub> (CIA/360) (L/s)	LENGTH (m)	PIPE WIDTH OR DIAMETER (mm)	PIPE HEIGHT (mm)	PIPE SHAPE (-)	MATERIAL (-)	CLASS (-)	SLOPE (%)	Q <sub>CAP</sub> (FULL) (L/s)	% FULL (-)	VEL. (FULL) (m/s)	VEL. (ACT) (m/s)	TIME OF FLOW (min)	
SITE-1	BLDG 107	107	0.00	0.00	0.00	0.00	0.00	0.00	0.00	0.00	0.00	0.000	0.000	0.000	0.000	0.000	0.000	0.000	0.000	0.000	10.00	76.81	104.19	122.14	178.56	0.0	0.0	0.0	12.8	150	150	CIRCULAR	PVC	-	1.00	15.3	0.00%	0.86	0.00	0.00
	107	105	0.04	0.00	0.00	0.00	0.00	0.85	0.00	0.00	0.00	0.033	0.033	0.000	0.000	0.000	0.000	0.000	0.000	0.000	10.00	76.81	104.19	122.14	178.56	0.0	0.0	7.1	11.4	300	300	CIRCULAR	PVC	-	0.50	68.0	10.44%	0.97	0.52	0.37
					10.37																																			
	106	105	0.24	0.00	0.00	0.00	0.00	0.85	0.00	0.00	0.00	0.202	0.202	0.000	0.000	0.000	0.000	0.000	0.000	0.000	10.00	76.81	104.19	122.14	178.56	0.0	0.0	43.1	63.1	300	300	CIRCULAR	PVC	-	0.50	68.0	63.32%	0.97	0.88	1.19
					11.19																																			
	108	105	0.15	0.00	0.00	0.00	0.00	0.74	0.00	0.00	0.00	0.110	0.110	0.000	0.000	0.000	0.000	0.000	0.000	0.000	10.00	76.81	104.19	122.14	178.56	0.0	0.0	23.5	17.2	300	300	CIRCULAR	PVC	-	0.40	60.8	38.70%	0.86	0.68	0.42
					10.42																																			
	105	104	0.09	0.00	0.00	0.00	0.00	0.55	0.00	0.00	0.00	0.050	0.395	0.000	0.000	0.000	0.000	0.000	0.000	0.000	11.19	72.52	98.30	115.20	168.37	0.0	0.0	79.6	25.8	300	300	CIRCULAR	PVC	-	0.70	80.4	98.91%	1.14	1.20	0.36
	104	103	0.00	0.00	0.00	0.00	0.00	0.00	0.00	0.00	0.00	0.000	0.395	0.000	0.000	0.000	0.000	0.000	0.000	0.000	11.55	71.33	96.67	113.28	165.54	0.0	0.0	78.3	7.9	300	300	CIRCULAR	PVC	-	0.70	80.4	97.29%	1.14	1.19	0.11
	103	102	0.00	0.00	0.00	0.00	0.00	0.00	0.00	0.00	0.00	0.000	0.395	0.000	0.000	0.000	0.000	0.000	0.000	0.000	11.66	70.97	96.18	112.70	164.69	0.0	0.0	77.9	46.4	300	300	CIRCULAR	PVC	-	0.70	80.4	96.80%	1.14	1.19	0.65
102	101	0.00	0.00	0.00	0.00	0.00	0.00	0.00	0.00	0.00	0.000	0.395	0.000	0.000	0.000	0.000	0.000	0.000	0.000	12.31	68.95	93.40	109.43	159.89	0.0	0.0	75.7	10.3	300	300	CIRCULAR	PVC	-	0.70	80.4	94.04%	1.14	1.18	0.14	
101	101A	0.00	0.00	0.00	0.00	0.00	0.00	0.00	0.00	0.00	0.000	0.395	0.000	0.000	0.000	0.000	0.000	0.000	0.000	12.45	68.51	92.80	108.73	158.86	0.0	0.0	75.2	3.5	300	300	CIRCULAR	PVC	-	0.70	80.4	93.45%	1.14	1.18	0.05	
				12.50																																				

### **D.3 Correspondence with the City of Ottawa (SWM Quality Control)**



## Wu, Michael

---

**From:** Rathnasooriya, Shika <Thakshika.Rathnasooriya@ottawa.ca>  
**Sent:** July 7, 2023 10:50  
**To:** Wu, Michael  
**Cc:** Gladish, Alyssa; Mott, Peter  
**Subject:** RE: 8 Withrow Avenue Sanitary Sewer Capacity Confirmation and SWM Quality Control Criteria

Hi Michael,

I apologies for the late reply. An enhanced level (80% TSS) of protection is required for water quality control on this site. Please let me know if you have any further questions.

Thanks,

**Shika Rathnasooriya, P.Eng**

Project Manager

Planning, Real Estate and Economic Development Department - West Branch

City of Ottawa

110 Laurier Avenue West Ottawa, ON

613.580.2424 ext. 23433

---

**From:** Wu, Michael <Michael.Wu@stantec.com>  
**Sent:** July 06, 2023 3:34 PM  
**To:** Rathnasooriya, Shika <Thakshika.Rathnasooriya@ottawa.ca>  
**Cc:** Gladish, Alyssa <Alyssa.Gladish@stantec.com>; Mott, Peter <Peter.Mott@stantec.com>  
**Subject:** RE: 8 Withrow Avenue Sanitary Sewer Capacity Confirmation and SWM Quality Control Criteria

**CAUTION: This email originated from an External Sender. Please do not click links or open attachments unless you recognize the source.**

**ATTENTION : Ce courriel provient d'un expéditeur externe. Ne cliquez sur aucun lien et n'ouvrez pas de pièce jointe, excepté si vous connaissez l'expéditeur.**

Good afternoon, Shika:

As a quick follow-up, I was wondering if you could provide the SWM Quality Control Criteria for the proposed site.

The site will have surface parking, and attached is the latest site plan for your reference.

Thanks,

**Michael Wu** EIT

Civil Engineering Intern, Community Development

Direct: 1 (613) 738-6033

Michael.Wu@stantec.com

Stantec

300-1331 Clyde Avenue

Ottawa ON K2C 3G4

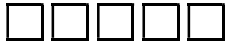

The content of this email is the confidential property of Stantec and should not be copied, modified, retransmitted, or used for any purpose except with Stantec's written authorization. If you are not the intended recipient, please delete all copies and notify us immediately.

---

**From:** Wu, Michael  
**Sent:** Wednesday, May 17, 2023 2:22 PM  
**To:** thakshika.rathnasooriya@ottawa.ca  
**Cc:** Gladish, Alyssa <Alyssa.Gladish@stantec.com>  
**Subject:** 8 Withrow Avenue Sanitary Sewer Capacity Confirmation and SWM Quality Control Criteria

Good afternoon, Shika:

In addition to the hydraulic boundary conditions, as part of the servicing for the proposed development on 8 Withrow Avenue and 7 Rossland Avenue, we would like to confirm if there is sufficient capacity downstream of the 200 mm diameter sanitary sewers in Withrow Avenue and Rossland Avenue and the 250 mm diameter sanitary sewer in Merivale Road to receive an additional peak flow of 2.4 L/s from the proposed development.

Please find our sanitary design sheet and location map attached for your information. Furthermore, it is my understanding that the City now provides the SWM quality control criteria. Are there any quality control measures applicable to the site?

On a side note, I will be away on vacation for two weeks starting this Friday afternoon. If you have any questions or have received the boundary conditions, please don't hesitate to reach out to Alyssa, who I have cc'd in this email.

Thanks,

**Michael Wu, EIT**  
Civil Engineering Intern, Community Development

Work: (613) 738-6033  
Mobile: (613) 858-0548  
[michael.wu@stantec.com](mailto:michael.wu@stantec.com)

Stantec  
300 - 1331 Clyde Avenue  
Ottawa ON K2C 3G4



The content of this email is the confidential property of Stantec and should not be copied, modified, retransmitted, or used for any purpose except with Stantec's written authorization. If you are not the intended recipient, please delete all copies and notify us immediately.

**Vacation Alert: I will be away on vacation from May 19<sup>th</sup> to June 2<sup>nd</sup>**

,

This e-mail originates from the City of Ottawa e-mail system. Any distribution, use or copying of this e-mail or the information it contains by other than the intended recipient(s) is unauthorized. Thank you.

Le présent courriel a été expédié par le système de courriels de la Ville d'Ottawa. Toute distribution, utilisation ou reproduction du courriel ou des renseignements qui s'y trouvent par une personne autre que son destinataire prévu est interdite. Je vous remercie de votre collaboration.

,

## D.4 Preliminary Stormceptor Sizing (SWM Quality Control)





# Stormceptor<sup>®</sup> EF Sizing Report

## STORMCEPTOR<sup>®</sup> ESTIMATED NET ANNUAL SEDIMENT (TSS) LOAD REDUCTION

07/07/2023

Province:	Ontario
City:	Ottawa
Nearest Rainfall Station:	OTTAWA CDA RCS
Climate Station Id:	6105978
Years of Rainfall Data:	20

Project Name:	Julian of Norwich (8Withrow Ave.)
Project Number:	160401691
Designer Name:	Peter Mott
Designer Company:	Stantec Consulting Ltd.
Designer Email:	peter.mott05@gmail.com
Designer Phone:	161-389-7044
EOR Name:	Robert Brandrick
EOR Company:	Stantec Consulting Ltd.
EOR Email:	robert.brandrick@stantec.com
EOR Phone:	403-716-8305

Site Name:	Julian of Norwich
------------	-------------------

Drainage Area (ha):	0.52
% Imperviousness:	74.30

Runoff Coefficient 'c': 0.74

Particle Size Distribution:	Fine
Target TSS Removal (%):	80.0

Required Water Quality Runoff Volume Capture (%):	90.00
Estimated Water Quality Flow Rate (L/s):	12.52
Oil / Fuel Spill Risk Site?	Yes
Upstream Flow Control?	Yes
Upstream Orifice Control Flow Rate to Stormceptor (L/s):	55.00
Peak Conveyance (maximum) Flow Rate (L/s):	77.00
Site Sediment Transport Rate (kg/ha/yr):	

Net Annual Sediment (TSS) Load Reduction Sizing Summary	
Stormceptor Model	TSS Removal Provided (%)
EFO4	86
EFO6	94
EFO8	97
EFO10	99
EFO12	100

**Recommended Stormceptor EFO Model: EFO4**  
**Estimated Net Annual Sediment (TSS) Load Reduction (%): 86**  
**Water Quality Runoff Volume Capture (%): > 90**

## Stormceptor® EF Sizing Report

### THIRD-PARTY TESTING AND VERIFICATION

► **Stormceptor® EF and Stormceptor® EFO** are the latest evolutions in the Stormceptor® oil-grit separator (OGS) technology series, and are designed to remove a wide variety of pollutants from stormwater and snowmelt runoff. These technologies have been third-party tested in accordance with the Canadian ETV **Procedure for Laboratory Testing of Oil-Grit Separators** and performance has been third-party verified in accordance with the **ISO 14034 Environmental Technology Verification (ETV)** protocol.

### PERFORMANCE

► **Stormceptor® EF and EFO** remove stormwater pollutants through gravity separation and floatation, and feature a patent-pending design that generates positive removal of total suspended solids (TSS) throughout each storm event, including high-intensity storms. Captured pollutants include sediment, free oils, and sediment-bound pollutants such as nutrients, heavy metals, and petroleum hydrocarbons. Stormceptor is sized to remove a high level of TSS from the frequent rainfall events that contribute the vast majority of annual runoff volume and pollutant load. The technology incorporates an internal bypass to convey excessive stormwater flows from high-intensity storms through the device without resuspension and washout (scour) of previously captured pollutants. Proper routine maintenance ensures high pollutant removal performance and protection of downstream waterways.

### PARTICLE SIZE DISTRIBUTION (PSD)

► The **Canadian ETV PSD** shown in the table below was used, or in part, for this sizing. This is the identical PSD that is referenced in the Canadian ETV **Procedure for Laboratory Testing of Oil-Grit Separators** for both sediment removal testing and scour testing. The Canadian ETV PSD contains a wide range of particle sizes in the sand and silt fractions, and is considered reasonably representative of the particle size fractions found in typical urban stormwater runoff.

Particle Size (µm)	Percent Less Than	Particle Size Fraction (µm)	Percent
1000	100	500-1000	5
500	95	250-500	5
250	90	150-250	15
150	75	100-150	15
100	60	75-100	10
75	50	50-75	5
50	45	20-50	10
20	35	8-20	15
8	20	5-8	10
5	10	2-5	5
2	5	<2	5



## Stormceptor<sup>®</sup> EF Sizing Report

### Upstream Flow Controlled Results

Rainfall Intensity (mm / hr)	Percent Rainfall Volume (%)	Cumulative Rainfall Volume (%)	Flow Rate (L/s)	Flow Rate (L/min)	Surface Loading Rate (L/min/m <sup>2</sup> )	Removal Efficiency (%)	Incremental Removal (%)	Cumulative Removal (%)
0.5	8.6	8.6	0.54	32.0	27.0	100	8.6	8.6
1	20.3	29.0	1.08	65.0	54.0	100	20.3	29.0
2	16.2	45.2	2.16	129.0	108.0	96	15.6	44.5
3	12.0	57.2	3.23	194.0	162.0	88	10.6	55.1
4	8.4	65.6	4.31	259.0	216.0	83	7.0	62.1
5	5.9	71.6	5.39	323.0	270.0	80	4.7	66.8
6	4.6	76.2	6.47	388.0	323.0	78	3.6	70.4
7	3.1	79.3	7.55	453.0	377.0	75	2.3	72.7
8	2.7	82.0	8.63	518.0	431.0	72	2.0	74.7
9	3.3	85.3	9.70	582.0	485.0	70	2.3	77.0
10	2.3	87.6	10.78	647.0	539.0	67	1.5	78.6
11	1.6	89.2	11.86	712.0	593.0	65	1.0	79.6
12	1.3	90.5	12.94	776.0	647.0	64	0.8	80.5
13	1.7	92.2	14.02	841.0	701.0	64	1.1	81.6
14	1.2	93.5	15.09	906.0	755.0	63	0.8	82.3
15	1.2	94.6	16.17	970.0	809.0	63	0.7	83.1
16	0.7	95.3	17.25	1035.0	863.0	63	0.4	83.5
17	0.7	96.1	18.33	1100.0	916.0	62	0.5	84.0
18	0.4	96.5	19.41	1164.0	970.0	62	0.2	84.2
19	0.4	96.9	20.48	1229.0	1024.0	61	0.3	84.5
20	0.2	97.1	21.56	1294.0	1078.0	60	0.1	84.6
21	0.5	97.5	22.64	1358.0	1132.0	59	0.3	84.9
22	0.2	97.8	23.72	1423.0	1186.0	57	0.1	85.0
23	1.0	98.8	24.80	1488.0	1240.0	56	0.6	85.6
24	0.3	99.1	25.88	1553.0	1294.0	55	0.1	85.7
25	0.9	100.0	26.95	1617.0	1348.0	54	0.5	86.2
30	0.9	100.9	32.34	1941.0	1617.0	45	0.4	86.6
35	-0.9	100.0	37.73	2264.0	1887.0	39	N/A	86.3
40	0.0	100.0	43.13	2588.0	2156.0	34	0.0	86.3
45	0.0	100.0	48.52	2911.0	2426.0	30	0.0	86.3
<b>Estimated Net Annual Sediment (TSS) Load Reduction =</b>								<b>86 %</b>

Climate Station ID: 6105978 Years of Rainfall Data: 20

**Stormceptor® EF Sizing Report**

**RAINFALL DATA FROM OTTAWA CDA RCS RAINFALL STATION**

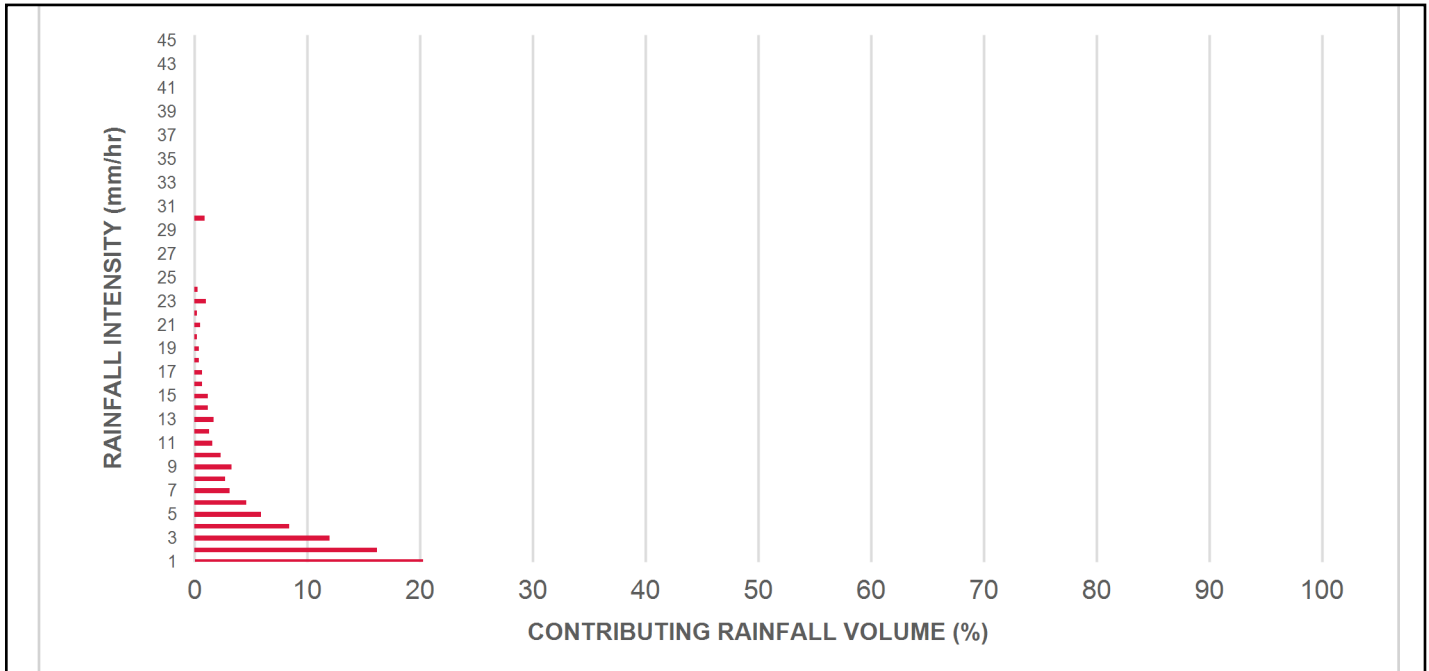

**INCREMENTAL AND CUMULATIVE TSS REMOVAL FOR THE RECOMMENDED STORMCEPTOR® MODEL**

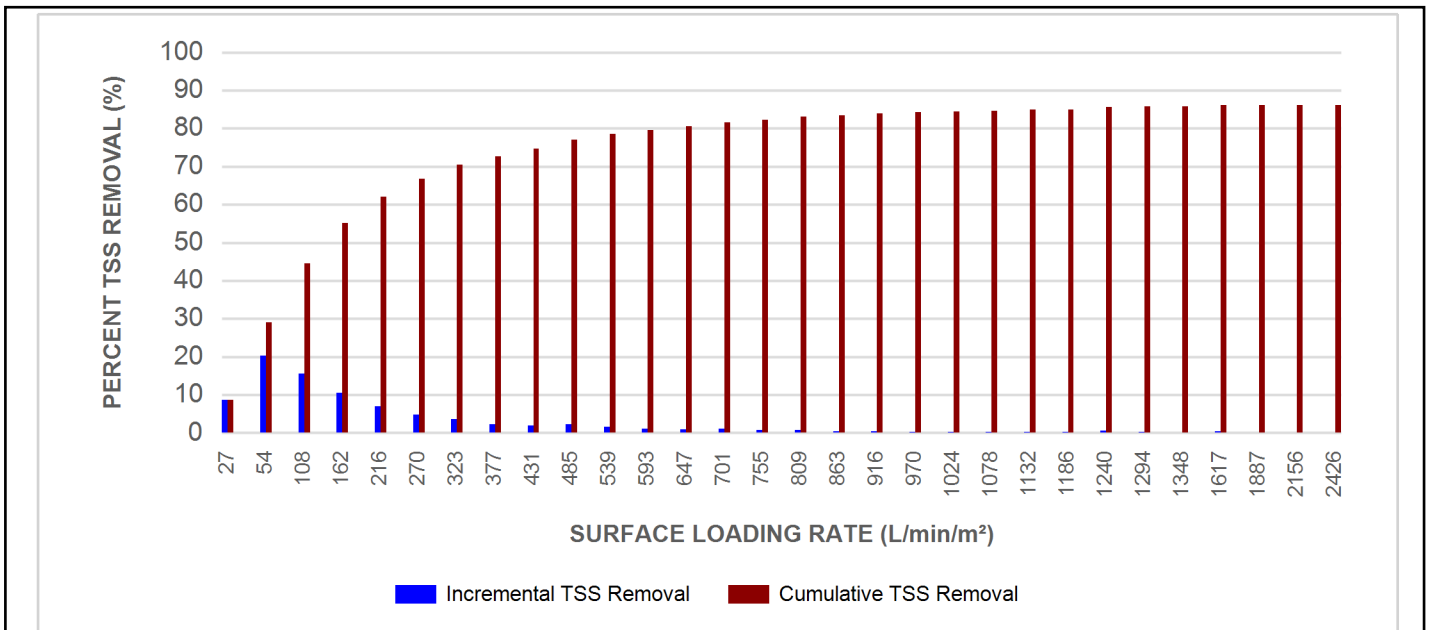

## Stormceptor® EF Sizing Report

### Maximum Pipe Diameter / Peak Conveyance

Stormceptor EF / EFO	Model Diameter		Min Angle Inlet / Outlet Pipes	Max Inlet Pipe Diameter		Max Outlet Pipe Diameter		Peak Conveyance Flow Rate	
	(m)	(ft)		(mm)	(in)	(mm)	(in)	(L/s)	(cfs)
EF4 / EFO4	1.2	4	90	609	24	609	24	425	15
EF6 / EFO6	1.8	6	90	914	36	914	36	990	35
EF8 / EFO8	2.4	8	90	1219	48	1219	48	1700	60
EF10 / EFO10	3.0	10	90	1828	72	1828	72	2830	100
EF12 / EFO12	3.6	12	90	1828	72	1828	72	2830	100

### SCOUR PREVENTION AND ONLINE CONFIGURATION

► **Stormceptor® EF and EFO** feature an internal bypass and superior scour prevention technology that have been demonstrated in third-party testing according to the scour testing provisions of the Canadian ETV **Procedure for Laboratory Testing of Oil-Grit Separators**, and the exceptional scour test performance has been third-party verified in accordance with the ISO 14034 ETV protocol. As a result, Stormceptor EF and EFO are approved for online installation, eliminating the need for costly additional bypass structures, piping, and installation expense.

### DESIGN FLEXIBILITY

► **Stormceptor® EF and EFO** offers design flexibility in one simplified platform, accepting stormwater flow from a single inlet pipe or multiple inlet pipes, and/or surface runoff through an inlet grate. The device can also serve as a junction structure, accommodate a 90-degree inlet-to-outlet bend angle, and can be modified to ensure performance in submerged conditions.

### OIL CAPTURE AND RETENTION

► While Stormceptor® EF will capture and retain oil from dry weather spills and low intensity runoff, **Stormceptor® EFO** has demonstrated superior oil capture and greater than 99% oil retention in third-party testing according to the light liquid re-entrainment testing provisions of the Canadian ETV **Procedure for Laboratory Testing of Oil-Grit Separators**. Stormceptor EFO is recommended for sites where oil capture and retention is a requirement.

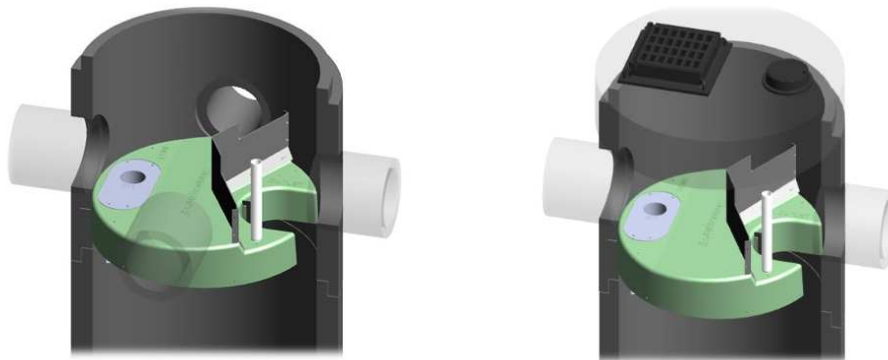

## Stormceptor® EF Sizing Report

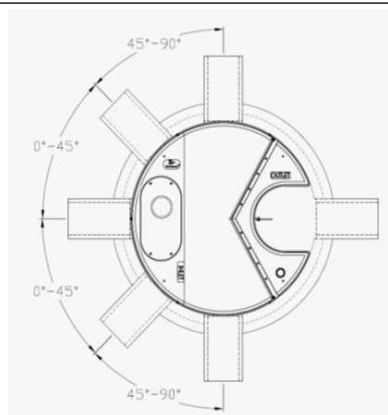

### INLET-TO-OUTLET DROP

Elevation differential between inlet and outlet pipe inverts is dictated by the angle at which the inlet pipe(s) enters the unit.

0° - 45° : The inlet pipe is 1-inch (25mm) higher than the outlet pipe.

45° - 90° : The inlet pipe is 2-inches (50mm) higher than the outlet pipe.

### HEAD LOSS

The head loss through Stormceptor EF is similar to that of a 60-degree bend structure. The applicable K value for calculating minor losses through the unit is 1.1.

For submerged conditions the applicable K value is 3.0.

### Pollutant Capacity

Stormceptor EF / EFO	Model Diameter		Depth (Outlet Pipe Invert to Sump Floor)		Oil Volume		Recommended Sediment Maintenance Depth *		Maximum Sediment Volume *		Maximum Sediment Mass **	
	(m)	(ft)	(m)	(ft)	(L)	(Gal)	(mm)	(in)	(L)	(ft <sup>3</sup> )	(kg)	(lb)
EF4 / EFO4	1.2	4	1.52	5.0	265	70	203	8	1190	42	1904	5250
EF6 / EFO6	1.8	6	1.93	6.3	610	160	305	12	3470	123	5552	15375
EF8 / EFO8	2.4	8	2.59	8.5	1070	280	610	24	8780	310	14048	38750
EF10 / EFO10	3.0	10	3.25	10.7	1670	440	610	24	17790	628	28464	78500
EF12 / EFO12	3.6	12	3.89	12.8	2475	655	610	24	31220	1103	49952	137875

\*Increased sump depth may be added to increase sediment storage capacity

\*\* Average density of wet packed sediment in sump = 1.6 kg/L (100 lb/ft<sup>3</sup>)

Feature	Benefit	Feature Appeals To
Patent-pending enhanced flow treatment and scour prevention technology	Superior, verified third-party performance	Regulator, Specifying & Design Engineer
Third-party verified light liquid capture and retention for EFO version	Proven performance for fuel/oil hotspot locations	Regulator, Specifying & Design Engineer, Site Owner
Functions as bend, junction or inlet structure	Design flexibility	Specifying & Design Engineer
Minimal drop between inlet and outlet	Site installation ease	Contractor
Large diameter outlet riser for inspection and maintenance	Easy maintenance access from grade	Maintenance Contractor & Site Owner

### STANDARD STORMCEPTOR EF/EFO DRAWINGS

For standard details, please visit <http://www.imbriumsystems.com/stormwater-treatment-solutions/stormceptor-ef>

### STANDARD STORMCEPTOR EF/EFO SPECIFICATION

For specifications, please visit <http://www.imbriumsystems.com/stormwater-treatment-solutions/stormceptor-ef>

## Stormceptor<sup>®</sup> EF Sizing Report

### STANDARD PERFORMANCE SPECIFICATION FOR “OIL GRIT SEPARATOR” (OGS) STORMWATER QUALITY TREATMENT DEVICE

#### PART 1 – GENERAL

##### 1.1 WORK INCLUDED

This section specifies requirements for selecting, sizing, and designing an underground Oil Grit Separator (OGS) device for stormwater quality treatment, with third-party testing results and a Statement of Verification in accordance with ISO 14034 Environmental Management – Environmental Technology Verification (ETV).

##### 1.2 REFERENCE STANDARDS & PROCEDURES

ISO 14034:2016 Environmental management – Environmental technology verification (ETV)

Canadian Environmental Technology Verification (ETV) Program’s **Procedure for Laboratory Testing of Oil-Grit Separators**

##### 1.3 SUBMITTALS

1.3.1 All submittals, including sizing reports & shop drawings, shall be submitted upon request with each order to the contractor then forwarded to the Engineer of Record for review and acceptance. Shop drawings shall detail all OGS components, elevations, and sequence of construction.

1.3.2 Alternative devices shall have features identical to or greater than the specified device, including: treatment chamber diameter, treatment chamber wet volume, sediment storage volume, and oil storage volume.

1.3.3 Unless directed otherwise by the Engineer of Record, OGS stormwater quality treatment product substitutions or alternatives submitted within ten days prior to project bid shall not be accepted. All alternatives or substitutions submitted shall be signed and sealed by a local registered Professional Engineer, based on the exact same criteria detailed in Section 3, in entirety, subject to review and approval by the Engineer of Record.

#### PART 2 – PRODUCTS

##### 2.1 OGS POLLUTANT STORAGE

The OGS device shall include a sump for sediment storage, and a protected volume for the capture and storage of petroleum hydrocarbons and buoyant gross pollutants. The minimum sediment & petroleum hydrocarbon storage capacity shall be as follows:

2.1.1	4 ft (1219 mm) Diameter OGS Units:	1.19 m <sup>3</sup> sediment / 265 L oil
	6 ft (1829 mm) Diameter OGS Units:	3.48 m <sup>3</sup> sediment / 609 L oil
	8 ft (2438 mm) Diameter OGS Units:	8.78 m <sup>3</sup> sediment / 1,071 L oil
	10 ft (3048 mm) Diameter OGS Units:	17.78 m <sup>3</sup> sediment / 1,673 L oil
	12 ft (3657 mm) Diameter OGS Units:	31.23 m <sup>3</sup> sediment / 2,476 L oil

#### PART 3 – PERFORMANCE & DESIGN

##### 3.1 GENERAL

The OGS stormwater quality treatment device shall be verified in accordance with ISO 14034:2016 Environmental management – Environmental technology verification (ETV). The OGS stormwater quality treatment device shall

## Stormceptor<sup>®</sup> EF Sizing Report

remove oil, sediment and gross pollutants from stormwater runoff during frequent wet weather events, and retain these pollutants during less frequent high flow wet weather events below the insert within the OGS for later removal during maintenance. The Manufacturer shall have at least ten (10) years of local experience, history and success in engineering design, manufacturing and production and supply of OGS stormwater quality treatment device systems, acceptable to the Engineer of Record.

### 3.2 SIZING METHODOLOGY

The OGS device shall be engineered, designed and sized to provide stormwater quality treatment based on treating a minimum of 90 percent of the average annual runoff volume and a minimum removal of an annual average 60% of the sediment (TSS) load based on the Particle Size Distribution (PSD) specified in the sizing report for the specified device. Sizing of the OGS shall be determined by use of a minimum ten (10) years of local historical rainfall data provided by Environment Canada. Sizing shall also be determined by use of the sediment removal performance data derived from the ISO 14034 ETV third-party verified laboratory testing data from testing conducted in accordance with the Canadian ETV protocol Procedure for Laboratory Testing of Oil-Grit Separators, as follows:

3.2.1 Sediment removal efficiency for a given surface loading rate and its associated flow rate shall be based on sediment removal efficiency demonstrated at the seven (7) tested surface loading rates specified in the protocol, ranging 40 L/min/m<sup>2</sup> to 1400 L/min/m<sup>2</sup>, and as stated in the ISO 14034 ETV Verification Statement for the OGS device.

3.2.2 Sediment removal efficiency for surface loading rates between 40 L/min/m<sup>2</sup> and 1400 L/min/m<sup>2</sup> shall be based on linear interpolation of data between consecutive tested surface loading rates.

3.2.3 Sediment removal efficiency for surface loading rates less than the lowest tested surface loading rate of 40 L/min/m<sup>2</sup> shall be assumed to be identical to the sediment removal efficiency at 40 L/min/m<sup>2</sup>. No extrapolation shall be allowed that results in a sediment removal efficiency that is greater than that demonstrated at 40 L/min/m<sup>2</sup>.

3.2.4 Sediment removal efficiency for surface loading rates greater than the highest tested surface loading rate of 1400 L/min/m<sup>2</sup> shall assume zero sediment removal for the portion of flow that exceeds 1400 L/min/m<sup>2</sup>, and shall be calculated using a simple proportioning formula, with 1400 L/min/m<sup>2</sup> in the numerator and the higher surface loading rate in the denominator, and multiplying the resulting fraction times the sediment removal efficiency at 1400 L/min/m<sup>2</sup>.

The OGS device shall also have sufficient annual sediment storage capacity as specified and calculated in Section 2.1.

### 3.3 CANADIAN ETV or ISO 14034 ETV VERIFICATION OF SCOUR TESTING

The OGS device shall have Canadian ETV or ISO 14034 ETV Verification of third-party scour testing conducted in accordance with the Canadian ETV Program's **Procedure for Laboratory Testing of Oil-Grit Separators**.

3.3.1 To be acceptable for on-line installation, the OGS device must demonstrate an average scour test effluent concentration less than 10 mg/L at each surface loading rate tested, up to and including 2600 L/min/m<sup>2</sup>.

### 3.4 LIGHT LIQUID RE-ENTRAINMENT SIMULATION TESTING

The OGS device shall have Canadian ETV or ISO 14034 ETV Verification of completed third-party Light Liquid Re-entrainment Simulation Testing in accordance with the Canadian ETV **Program's Procedure for Laboratory Testing of Oil-Grit Separators**, with results reported within the Canadian ETV or ISO 14034 ETV verification. This re-entrainment testing is conducted with the device pre-loaded with low density polyethylene (LDPE) plastic beads as a surrogate for light liquids such as oil and fuel. Testing is conducted on the same OGS unit tested for sediment removal to



## Stormceptor<sup>®</sup> EF Sizing Report

assess whether light liquids captured after a spill are effectively retained at high flow rates.

3.4.1 For an OGS device to be an acceptable stormwater treatment device on a site where vehicular traffic occurs and the potential for an oil or fuel spill exists, the OGS device must have reported verified performance results of greater than 99% cumulative retention of LDPE plastic beads for the five specified surface loading rates (ranging 200 L/min/m<sup>2</sup> to 2600 L/min/m<sup>2</sup>) in accordance with the Light Liquid Re-entrainment Simulation Testing within the Canadian ETV Program's **Procedure for Laboratory Testing of Oil-Grit Separators**. However, an OGS device shall not be allowed if the Light Liquid Re-entrainment Simulation Testing was performed with screening components within the OGS device that are effective at retaining the LDPE plastic beads, but would not be expected to retain light liquids such as oil and fuel.

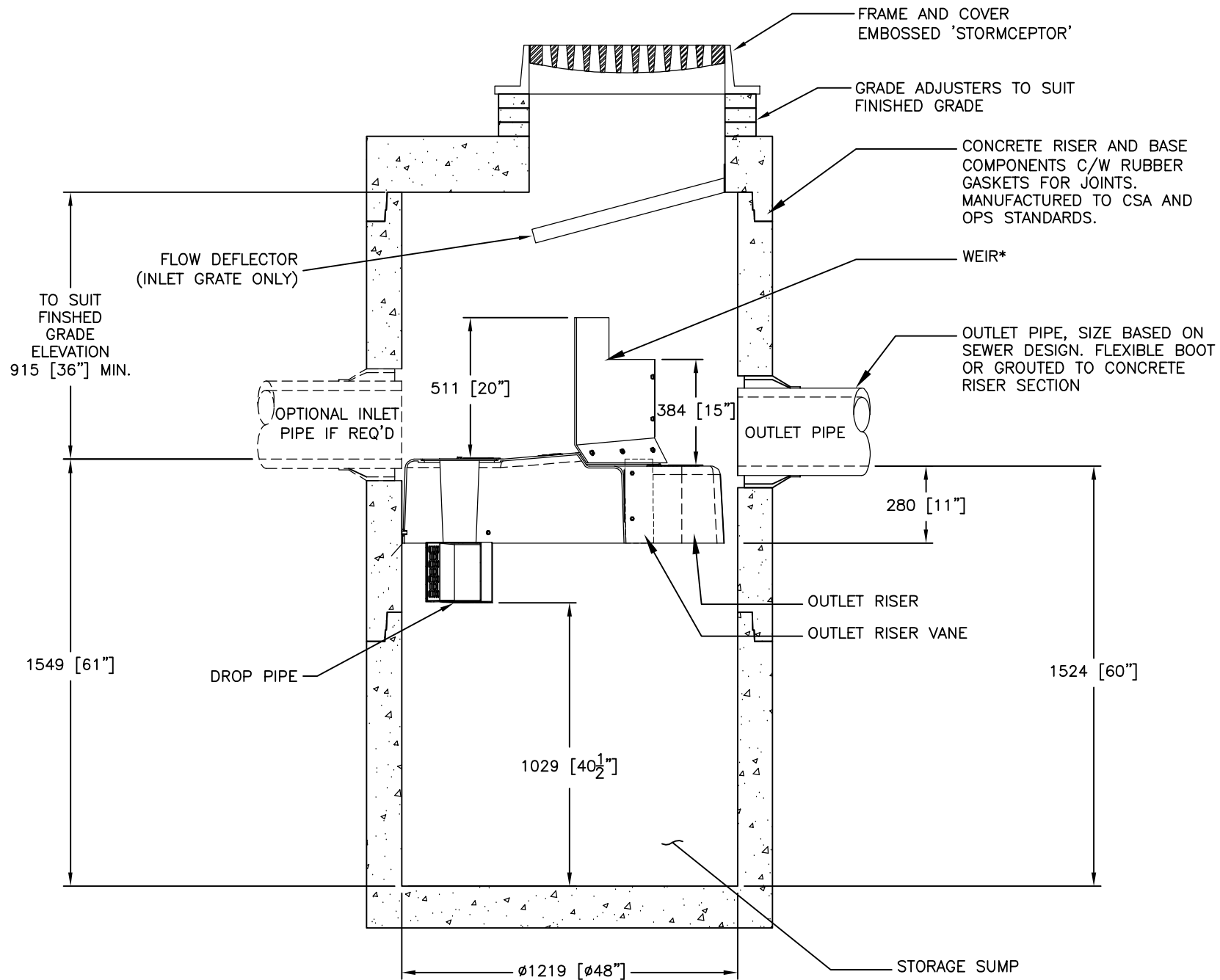

SECTION VIEW

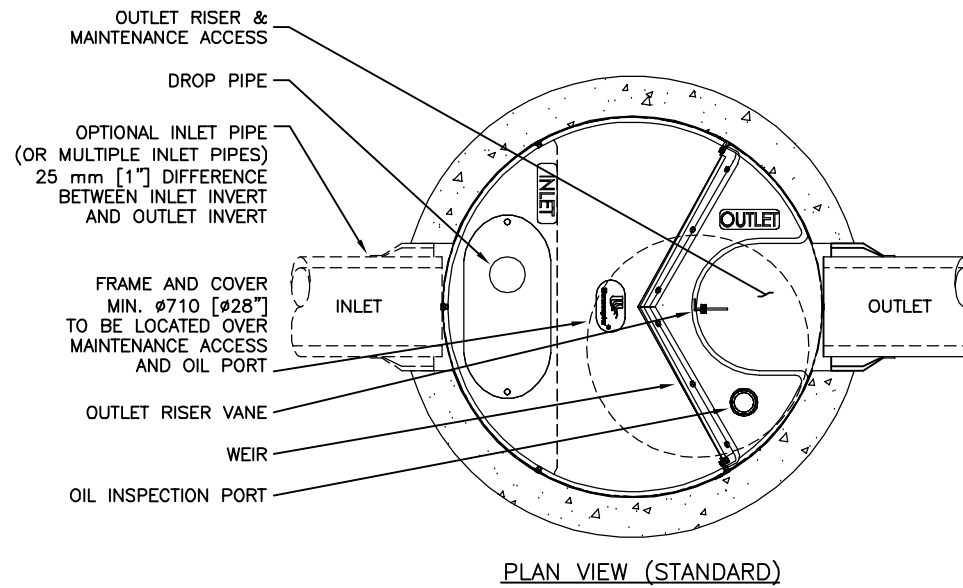

PLAN VIEW (STANDARD)

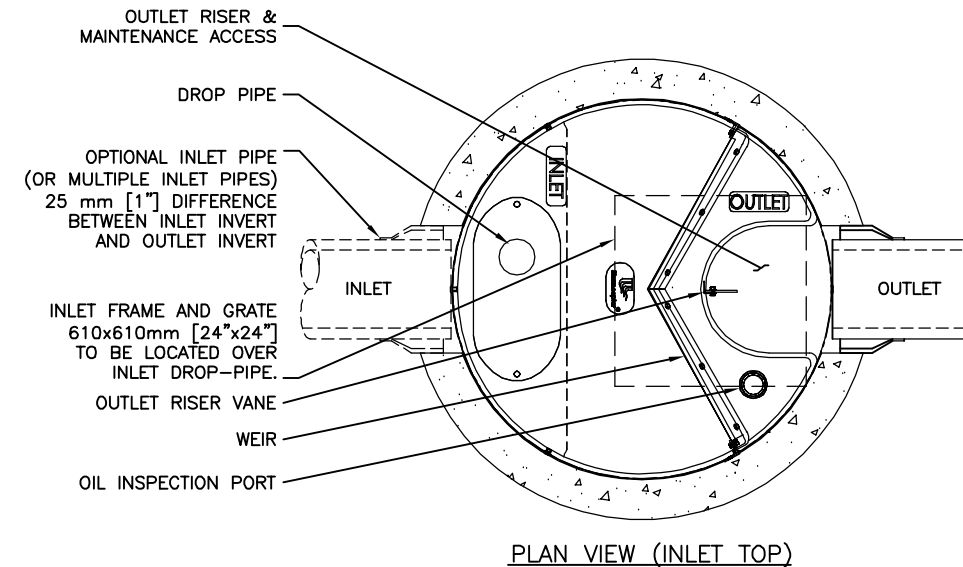

PLAN VIEW (INLET TOP)

FOR SITE SPECIFIC DRAWINGS PLEASE CONTACT YOUR LOCAL STORMCEPTOR REPRESENTATIVE. SITE SPECIFIC DRAWINGS ARE BASED ON THE BEST AVAILABLE INFORMATION AT THE TIME. SOME FIELD REVISIONS TO THE SYSTEM LOCATION OR CONNECTION PIPING MAY BE NECESSARY BASED ON AVAILABLE SPACE OR SITE CONFIGURATION REVISIONS. ELEVATIONS SHOULD BE MAINTAINED EXCEPT WHERE NOTED ON BYPASS STRUCTURE (IF REQUIRED).

**GENERAL NOTES:**

- \* MAXIMUM SURFACE LOADING RATE (SLR) INTO LOWER CHAMBER THROUGH DROP PIPE IS 1135 L/min/m<sup>2</sup> (27.9 gpm/ft<sup>2</sup>) FOR STORMCEPTOR EF4 AND 535 L/min/m<sup>2</sup> (13.1 gpm/ft<sup>2</sup>) FOR STORMCEPTOR EFO4 (OIL CAPTURE CONFIGURATION). WEIR HEIGHT IS 150 mm (6 INCH) FOR EF04.
- 1. ALL DIMENSIONS INDICATED ARE IN MILLIMETERS (INCHES) UNLESS OTHERWISE SPECIFIED.
- 2. STORMCEPTOR STRUCTURE INLET AND OUTLET PIPE SIZE AND ORIENTATION SHOWN FOR INFORMATIONAL PURPOSES ONLY.
- 3. UNLESS OTHERWISE NOTED, BYPASS INFRASTRUCTURE, SUCH AS ALL UPSTREAM DIVERSION STRUCTURES, CONNECTING STRUCTURES, OR PIPE CONDUITS CONNECTING TO COMPLETE THE STORMCEPTOR SYSTEM SHALL BE PROVIDED AND ADDRESSED SEPARATELY.
- 4. DRAWING FOR INFORMATION PURPOSES ONLY. REFER TO ENGINEER'S SITE/UTILITY PLAN FOR STRUCTURE ORIENTATION.
- 5. NO PRODUCT SUBSTITUTIONS SHALL BE ACCEPTED UNLESS SUBMITTED 10 DAYS PRIOR TO PROJECT BID DATE, OR AS DIRECTED BY THE ENGINEER OF RECORD.

**INSTALLATION NOTES**

- A. ANY SUB-BASE, BACKFILL DEPTH, AND/OR ANTI-FLOTATION PROVISIONS ARE SITE-SPECIFIC DESIGN CONSIDERATIONS AND SHALL BE SPECIFIED BY ENGINEER OF RECORD.
- B. CONTRACTOR TO PROVIDE EQUIPMENT WITH SUFFICIENT LIFTING AND REACH CAPACITY TO LIFT AND SET THE STRUCTURE (LIFTING CLUTCHES PROVIDED)
- C. CONTRACTOR WILL INSTALL AND LEVEL THE STRUCTURE, SEALING THE JOINTS, LINE ENTRY AND EXIT POINTS (NON-SHRINK GROUT WITH APPROVED WATERSTOP OR FLEXIBLE BOOT)
- D. CONTRACTOR TO TAKE APPROPRIATE MEASURES TO PROTECT THE DEVICE FROM CONSTRUCTION-RELATED EROSION RUNOFF.
- E. DEVICE ACTIVATION, BY CONTRACTOR, SHALL OCCUR ONLY AFTER SITE HAS BEEN STABILIZED AND THE STORMCEPTOR UNIT IS CLEAN AND FREE OF DEBRIS.

# STANDARD DETAIL NOT FOR CONSTRUCTION

SITE SPECIFIC DATA REQUIREMENTS						
STORMCEPTOR MODEL	EF4					
STRUCTURE ID	*					
WATER QUALITY FLOW RATE (L/s)	*					
PEAK FLOW RATE (L/s)	*					
RETURN PERIOD OF PEAK FLOW (yrs)	*					
DRAINAGE AREA (HA)	*					
DRAINAGE AREA IMPERVIOUSNESS (%)	*					
PIPE DATA:	I.E.	MAT'L	DIA	SLOPE %	HGL	
INLET #1	*	*	*	*	*	
INLET #2	*	*	*	*	*	
OUTLET	*	*	*	*	*	
* PER ENGINEER OF RECORD						

This design and information is provided as a service to the project owner, engineer and contractor by Imbrium Systems ("Imbrium"). Neither the drawing, nor any part thereof, may be reproduced, stored in a retrieval system, or transmitted in any form or by any means, electronic, mechanical, photocopying, recording, or by any information storage and retrieval system, without the prior written consent of Imbrium. Imbrium expressly disclaims any liability or responsibility for such use. If discrepancies between the supplied information upon which the drawing is based and actual field conditions are discovered, the contractor shall be responsible for re-evaluation of the design. Imbrium accepts no liability for designs based on missing, incomplete or inaccurate information supplied by others.

MARK	DATE	REVISION DESCRIPTION	BY
###	###	INITIAL RELEASE	JSK
###	###	UPDATES	JSK

Stormceptor® EF

imbrium

7037 RIDGE ROAD, SUITE 300, HANOVER, MD 21076  
USA 888-276-8828 CA 800-568-4801 INTL. +1-410-960-9600  
THE ENGINEER/ARCHITECT/PLANNING/CONSULTING FIRM OR THE CONTRACTOR/OWNER SHALL BE RESPONSIBLE FOR OBTAINING ALL NECESSARY PERMITS AND APPROVALS FROM ALL APPLICABLE AGENCIES. THE CONTRACTOR SHALL BE RESPONSIBLE FOR OBTAINING ALL NECESSARY PERMITS AND APPROVALS FROM ALL APPLICABLE AGENCIES. THE CONTRACTOR SHALL BE RESPONSIBLE FOR OBTAINING ALL NECESSARY PERMITS AND APPROVALS FROM ALL APPLICABLE AGENCIES.

DATE: 5/26/2017

DESIGNED: JSK	DRAWN: JSK
CHECKED: BSF	APPROVED: SP
PROJECT No.: EF4	SEQUENCE No.: *
SHEET: 1	OF 1