

1 REFERENCE SITE PLAN & EXTENT OF RETAINING WALLS
SCALE:1:250

*UNDERLAY IS PORTION OF LRL JOB NO. 230202 "GRADING AND DRAINAGE PLAN" C-301, r3.
SEE REFERENCE DRAWING FOR ADDITIONAL GRADES.

FEATURES ON REFERENCE PLANS SHALL REMAIN AS SHOWN THERE, UNLESS MODIFIED ON THIS SHEET.

GENERAL:

- GOVERNING CODE: ONTARIO BUILDING CODE LATEST EDITION (2012).
- ALL DIMENSIONS AND DETAILS GIVEN ON THESE STRUCTURAL DRAWINGS MUST BE COORDINATED WITH OTHER DISCIPLINES INVOLVED. ANY INCONSISTENCY MUST BE REPORTED TO THE STRUCTURAL ENGINEER BEFORE PROCEEDING WITH THE WORK.
- THESE DRAWINGS TO BE READ IN CONJUNCTION WITH THE RELEVANT CIVIL DRAWINGS.
- DRAWINGS MUST NOT BE SCALED.
- ALL CONSTRUCTION, SHORING, DETAILING, EXCAVATIONS, etc. MUST BE AS PER OCCUPATIONAL HEALTH AND SAFETY ACT AND REGULATIONS FOR CONSTRUCTION PROJECTS. GENERAL CONTRACTOR WILL BE RESPONSIBLE FOR ALL COSTS ASSOCIATED WITH TEMPORARY WORKS.
- SUFFICIENT TEMPORARY BRACING SHALL BE PROVIDED TO KEEP THE WALLS FORMS AND ALL SHORING SAFE, PLUMB AND IN TRUE ALIGNMENT DURING CONSTRUCTION.
- CONTRACTOR TO SUBMIT FOLLOWING DRAWINGS TO THE STRUCTURAL ENGINEER OF RECORD FOR REVIEW PRIOR TO COMMENCEMENT OF ACTUAL WORK:

DRAWINGS DETAIL	ENGINEER'S STAMP
7.1. CONCRETE DESIGN MIX	NO
7.2. REBAR SHOP DRAWINGS	NO
- CONTRACTOR TO CONSULT GEOTECHNICAL REPORT PREPARED BY LRL (PROJECT 230202, DATED JANUARY 2024, BEFORE BEGINNING EXCAVATION. FENCE
 - DESIGN TO NAAMM AMP 521-01 (R2012)
 - ALL TUBE IS ASTM A500, GRADE B, OR BETTER
 - TYPE 2 JOINT CONSTRUCTION
 - FINISH: 1 COAT SHOP PRIMER + 1 COAT BLACK ENAMEL
 - CONFIRM WALL LAYOUT ON SITE BEFORE FABRICATION
 - POST TO BE VERTICAL REGARDLESS OF TOP OF WALL, ADJUST SKEW OR STEP AS REQUIRED.
 - WELDING TO CSA W59

REINFORCED AND PLAIN CONCRETE:

- CONCRETE AND REINFORCEMENT INSTALLATION TO CONFORM TO LATEST EDITIONS OF CSA A23.1, A23.2 AND A23.4.
- CONCRETE MIX TO BE DESIGNED BY SUPPLIER TO MEET THE PERFORMANCE SPECIFICATION NOTED IN THE MIXES TABLE.
- REINFORCING BARS TO CONFORM TO CAN CSA G30.18-M92(R2002) LATEST EDITION $F_y=400 \text{ MPa}$
- WHEN TWO ELEMENTS OF DIFFERENT STRENGTHS ARE PLACED DURING THE SAME POUR, USE CONCRETE OF THE ELEMENT WITH HIGHER STRENGTH.
- ALL REBAR SHALL HAVE 50mm COVER UNLESS OTHERWISE NOTED.
- NO OPENING, PENETRATION OR SLEEVE THROUGH STRUCTURAL ELEMENTS SHALL BE INSTALLED UNLESS APPROVED BY STRUCTURAL ENGINEER OR GIVEN ON THE DRAWING.
- CONTRACTOR TO GET A PRE-APPROVAL FROM STRUCTURAL ENGINEER FOR JOINTS NOT SHOWN ON DRAWINGS.
- CURING OF CONCRETE SHALL BE DONE ACCORDING TO CLAUSE 21-A23.1 AND LAST 3 DAYS MIN.
- CONCRETE TO BE PROTECTED FROM EXCESSIVE HEAT AND COLD; REFER TO COLD AND HOT WEATHER PROTECTION PROCEDURES.
- DO NOT BACKFILL SLABS OR WALLS FOR 7 DAYS AFTER PLACING CONCRETE.
- FORM WORK CONTRACTOR TO FORM ALL HOLES, CHASES etc. AND TO SET INSERTS, ANCHOR BOLTS AND OTHER EMBEDDED MEMBERS ARE REQUIRED TO BE HELD IN PLACE BY THE FORM WORK BEFORE POURING THE CONCRETE.
- ALL CAST IN PLACE CONCRETE TO BE VIBRATED THOROUGHLY.

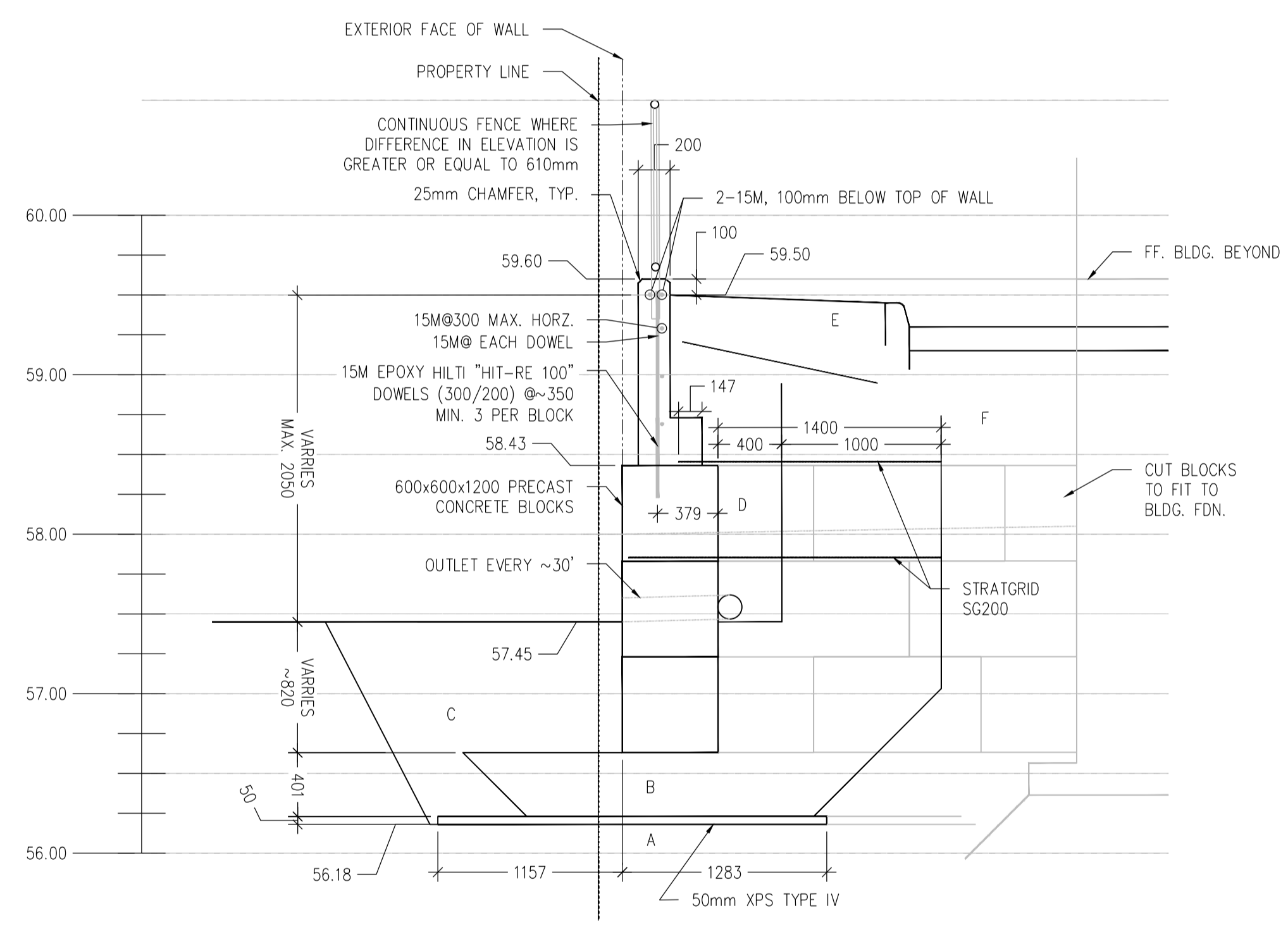
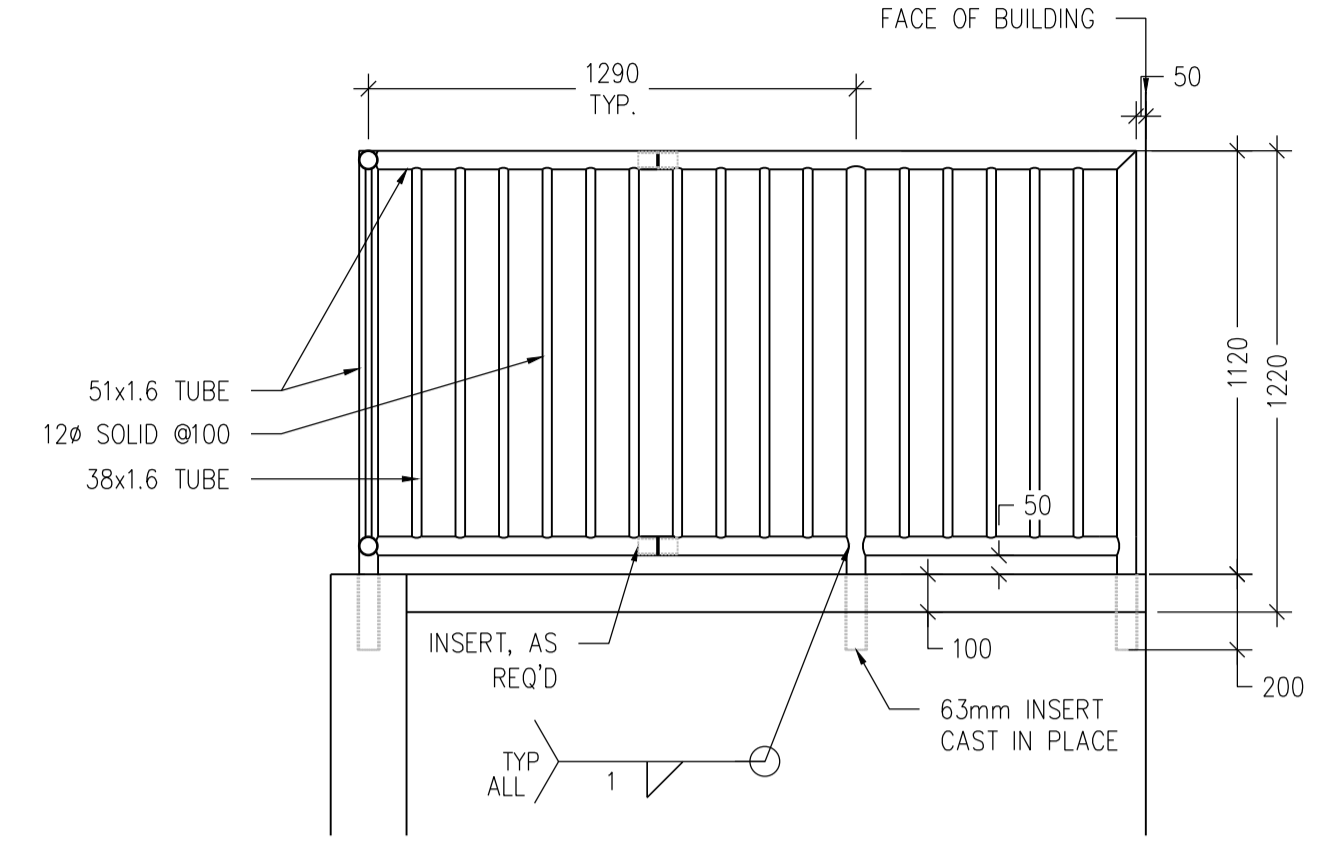

- A: UNDISTURBED NATIVE MATERIAL WITH ALLOWABLE BEARING OF 90kPa (SL5)
- B: NON-FROST SUSEPTABLE STRUCTURAL FILL, OPSS GRAULAR A COMPACTED TO 98% SPDD
- C: NATIVE BACKFILL
- D: CLEAR 2" GRANULAR
- E: TOP SOIL
- F: ROAD/PARKING BASE, SEE CIVIL & GEO

USE AND INTERPRETATION OF DRAWINGS

GENERAL CONDITIONS OF THE CONTRACT FOR CONSTRUCTION ARE PART OF THE CONTRACT DOCUMENTS AND DESCRIBE USE AND INTENT OF THE DRAWING. THE CONTRACT DOCUMENTS INCLUDE NOT ONLY THE DRAWINGS, BUT ALSO THE OWNER-CONTRACTOR AGREEMENTS, CONDITIONS OF THE CONTRACT, THE SPECIFICATIONS, ADDENDA, AND MODIFICATIONS ISSUED AFTER EXECUTION OF THE CONTRACT. THESE CONTRACT DOCUMENTS ARE COMPLEMENTARY, AND WHAT IS REQUIRED BY ANY ONE SHALL BE BINDING AS IF REQUIRED BY ALL. WORK NOT COMPLETELY DELINEATED HEREON SHALL BE CONSTRUCTED OF THE SAME MATERIALS AND DETAILED SIMILARLY AS WORK SHOWN MORE COMPLETELY ELSEWHERE IN THE CONTRACT DOCUMENTS.

BY USE OF THE DRAWINGS FOR CONSTRUCTION OF THE PROJECT, THE OWNER CONFIRMS THAT HE HAS REVIEWED AND APPROVED THE DRAWINGS. THE CONTRACTOR CONFIRMS THAT HE HAS VISITED THE SITE, FAMILIARIZED HIMSELF WITH THE LOCAL CONDITIONS, VERIFIED FIELD DIMENSIONS AND CORRELATED HIS OBSERVATIONS WITH THE REQUIREMENTS OF THE CONTRACT DOCUMENTS.

AS INSTRUMENTS OF SERVICE, ALL DRAWINGS, SPECIFICATIONS, CAD FILES OR OTHER ELECTRONIC MEDIA AND COPIES THERE OF FURNISHED BY THE ENGINEER ARE HIS PROPERTY. THEY ARE TO BE USED ONLY FOR THIS PROJECT AND ARE NOT TO BE USED ON ANY OTHER PROJECT, INCLUDING REPEATS OF THE PROJECT. CHANGES TO THE DRAWINGS MAY ONLY BE MADE BY THE ENGINEER.

UNLESS THE REVISION TITLE IS "ISSUED FOR CONSTRUCTION", THESE DRAWINGS SHALL BE CONSIDERED PRELIMINARY AND SHALL NOT BE USED AS A CONSTRUCTION DOCUMENT.

THESE DRAWINGS ILLUSTRATE THE WORK TO BE DONE. THE ENGINEER IS NOT RESPONSIBLE FOR THE MEANS, METHODS, TECHNIQUES, SEQUENCES, AND PROCEDURES USED TO DO THE WORK, OR THE SAFETY ASPECTS OF CONSTRUCTION, AND NOTHING ON THESE DRAWINGS EXPRESSED OR IMPLIED CHANGES THIS CONDITION. CONTRACTOR SHALL DETERMINE ALL CONDITIONS AT THE SITE AND SHALL BE RESPONSIBLE FOR KNOWING HOW THEY AFFECT THE WORK. SUBMITTAL OF A BID TO PERFORM THIS WORK IS ACKNOWLEDGEMENT OF THE RESPONSIBILITIES, AND THAT THEY HAVE BEEN FULLY CONSIDERED IN PLANNING OF THE WORK, AND THE BID PRICE. NO CLAIMS FOR EXTRA CHARGES DUE TO THESE CONDITIONS WILL BE FORTHCOMING.

UNAUTHORIZED CHANGES:

IN THE EVENT THE CLIENT, THE CLIENT'S CONTRACTORS OR SUBCONTRACTORS, OR ANYONE FOR WHOM THE CLIENT IS LEGALLY LIABLE MAKES OR PERMITS TO BE MADE ANY CHANGES TO ANY REPORTS, PLANS, SPECIFICATIONS OR OTHER CONSTRUCTION DOCUMENTS PREPARED BY LRL ASSOCIATES LTD. (LRL) WITHOUT OBTAINING LRL'S PRIOR WRITTEN CONSENT, THE CLIENT SHALL ASSUME FULL RESPONSIBILITY FOR THE RESULTS OF SUCH CHANGES. THEREFORE THE CLIENT AGREES TO WAIVE ANY CLAIM AGAINST LRL AND TO RELEASE LRL FROM ANY LIABILITY ARISING DIRECTLY OR INDIRECTLY FROM SUCH UNAUTHORIZED CHANGES.

IN ADDITION, THE CLIENT AGREES, TO THE FULLEST EXTENT PERMITTED BY LAW, TO INDEMNIFY AND HOLD HARMLESS LRL FROM ANY DAMAGES, LIABILITIES OR COST, INCLUDING REASONABLE ATTORNEY'S FEES AND COST OF DEFENSE, ARISING FROM SUCH CHANGES.

GENERAL NOTES:

EXISTING SERVICES AND UTILITIES SHOWN ON THESE DRAWINGS ARE TAKEN FROM THE BEST AVAILABLE RECORDS, BUT MAY NOT BE COMPLETE OR TO DATE. CONTRACTOR SHALL VERIFY IN FIELD FOR LOCATION AND ELEVATION OF PIPES AND CHECK WITH THE UTILITY COMPANIES BEFORE DIGGING OR PERFORMING WORK.

CONTRACTOR IS ADVISED TO COLLECT INFORMATION ON SOIL CONDITIONS BEFORE START OF CONSTRUCTION.

THE ENGINEER WAIVES ANY AND ALL RESPONSIBILITY AND LIABILITY FOR PROBLEMS WHICH ARISE FROM FAILURE TO FOLLOW THESE PLANS, SPECIFICATIONS AND THE DESIGN INTENT THEY CONVEY, OR FOR PROBLEMS WHICH ARISE FROM OTHERS' FAILURE TO OBTAIN AND/OR FOLLOW THE ENGINEER'S GUIDANCE WITH RESPECT TO ANY ERRORS, OMISSIONS, INCONSISTENCIES AMBIGUITIES OR CONFLICTS WHICH ARE ALLEGED.

CONTRACTOR TO VERIFY ALL DIMENSIONS AND NOTIFY THE ENGINEER OF ANY DISCREPANCIES BEFORE WORK COMMENCES. DO NOT SCALE DRAWINGS.

No.	REVISIONS	BY	DATE
01	ISSUED FOR APPROVAL	E.S.	25 JUN 2024



NOT AUTHENTIC UNLESS SIGNED AND DATED

LRL
ENGINEERING | INGÉNIERIE
5430 Canotek Road | Ottawa, ON, K1J 9G2
www.lrl.ca | (613) 842-3434

DESIGNED BY:	DRAWN BY:	APPROVED BY:
E.S.	E.S.	E.S.

PROJECT
PLAZA TRIM ROAD DEVELOPMENT
1280 TRIM RD,
OTTAWA, ON

DRAWING TITLE
RETAINING WALL
LAYOUT AND
DETAILS

PROJECT NO.	230202
DATE	JUNE 25, 2024

