

1 | DECIDUOUS TREE PLANTING

LT-6 | 1:15

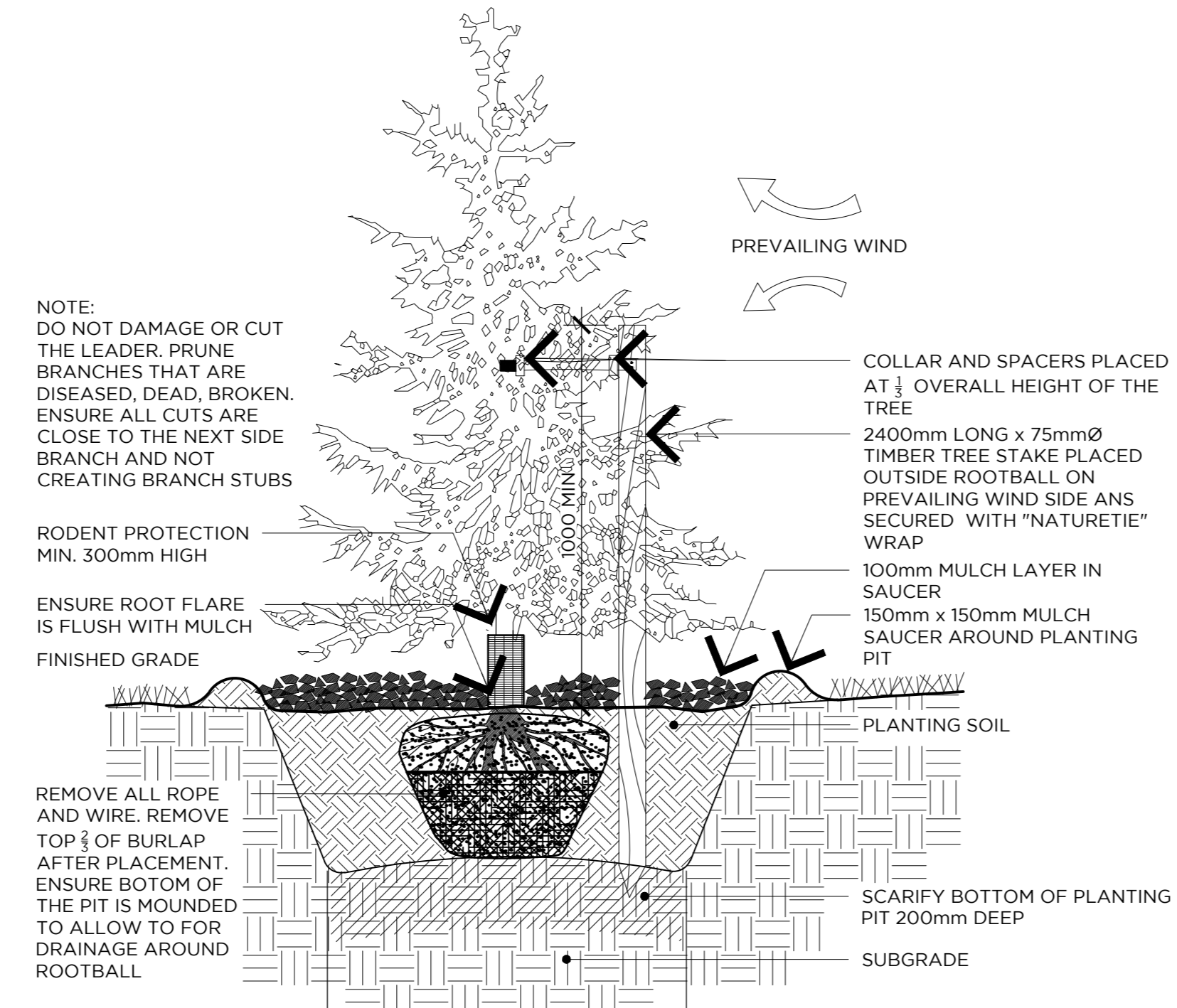

2 | CONIFEROUS TREE PLANTING

LT-6 | 1:15

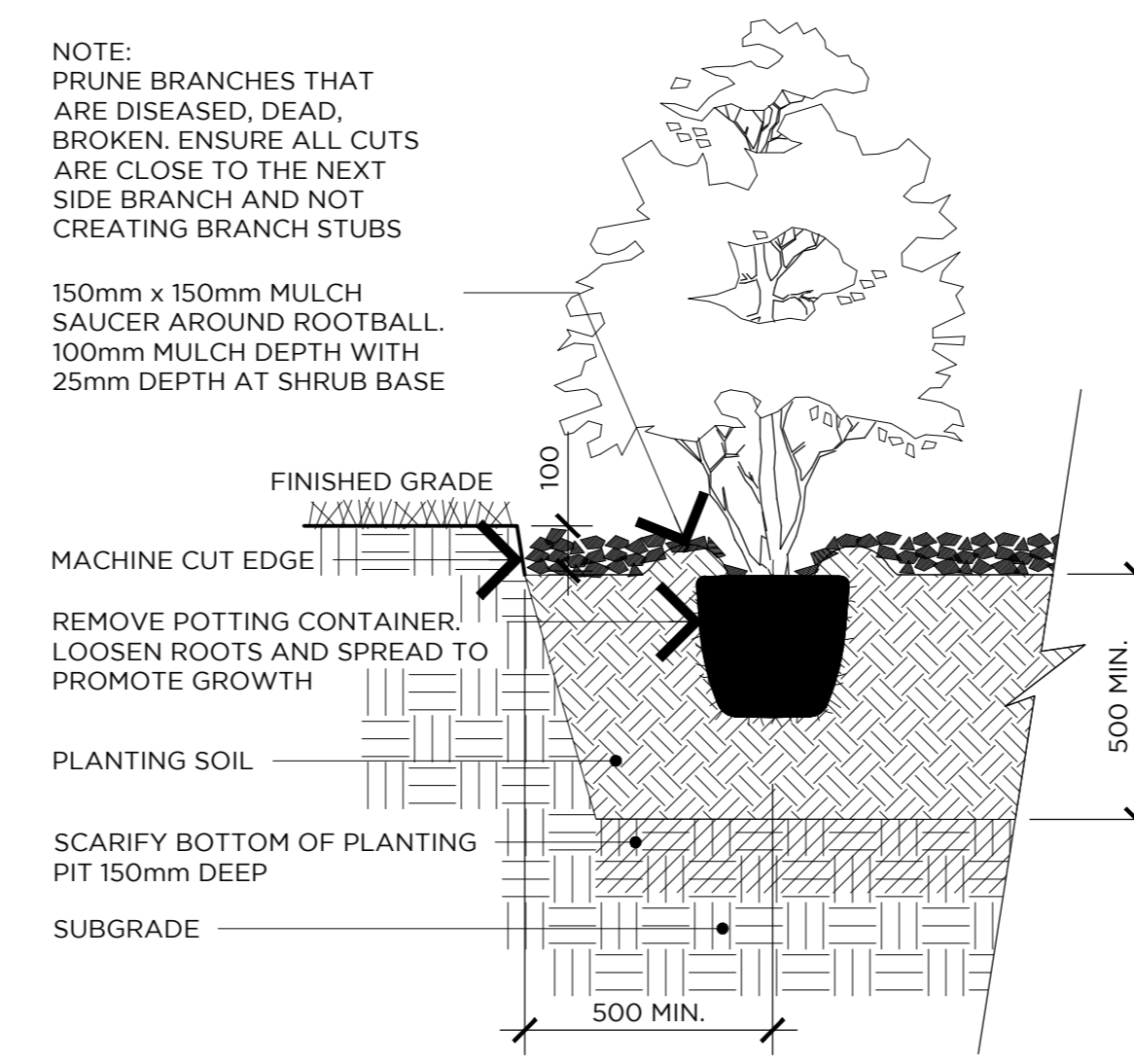

3 | SHRUB PLANTING

LT-6 | NTS

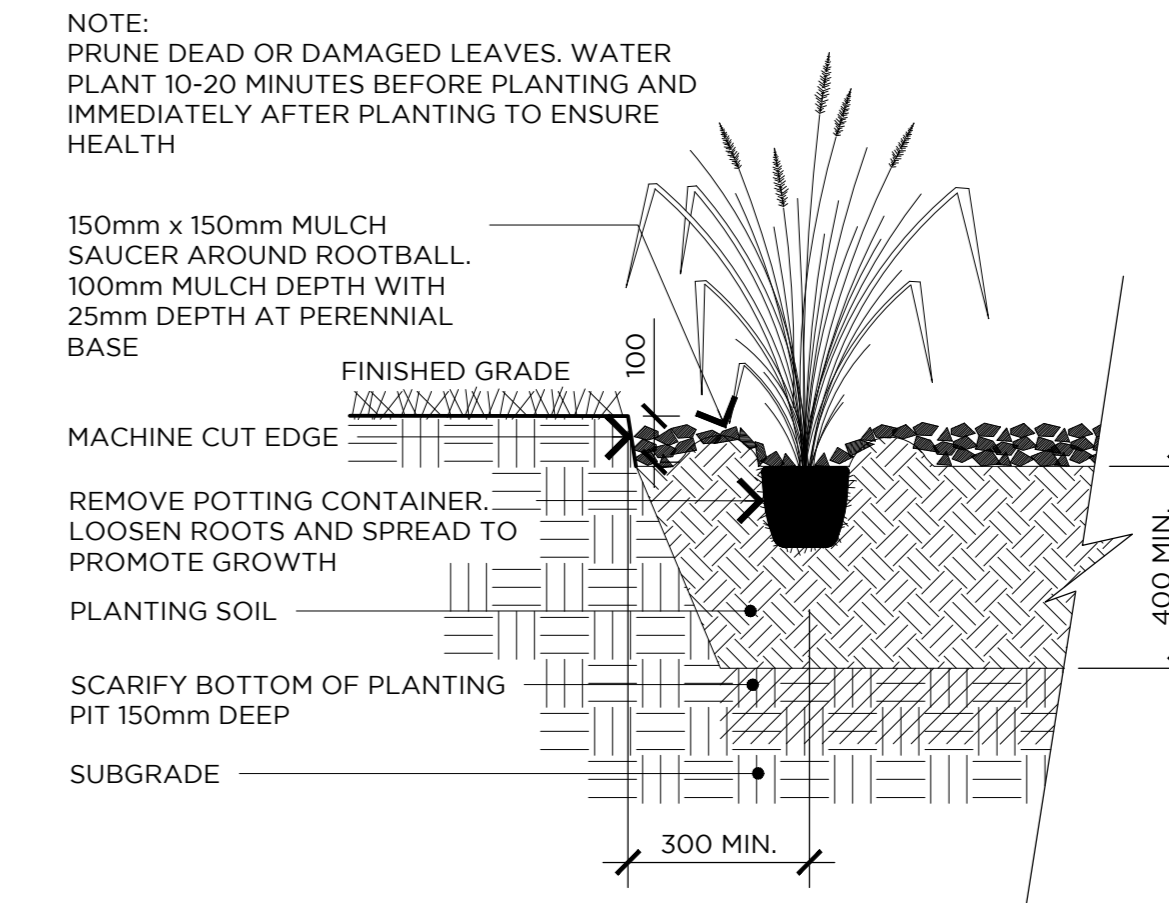

4 | PERENNIAL GRASS PLANTING

LT-6 | NTS

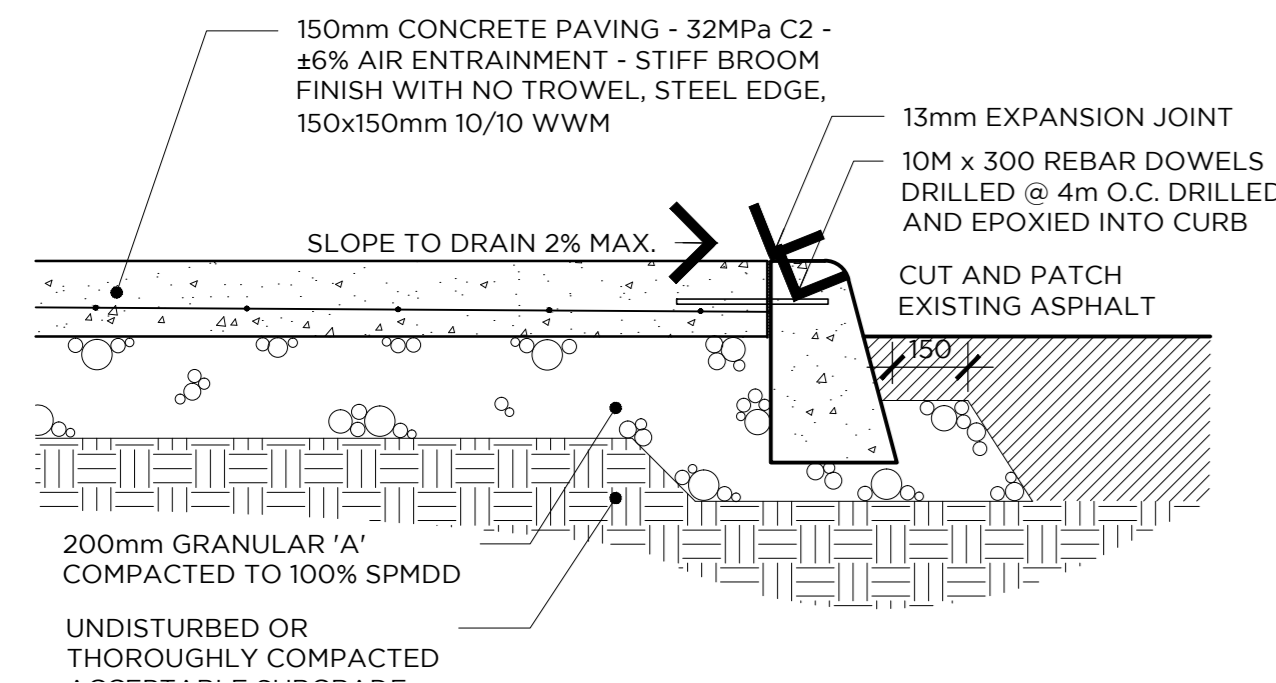

5 | LIGHT DUTY CONCRETE PAVING

LT-6 | 1:15

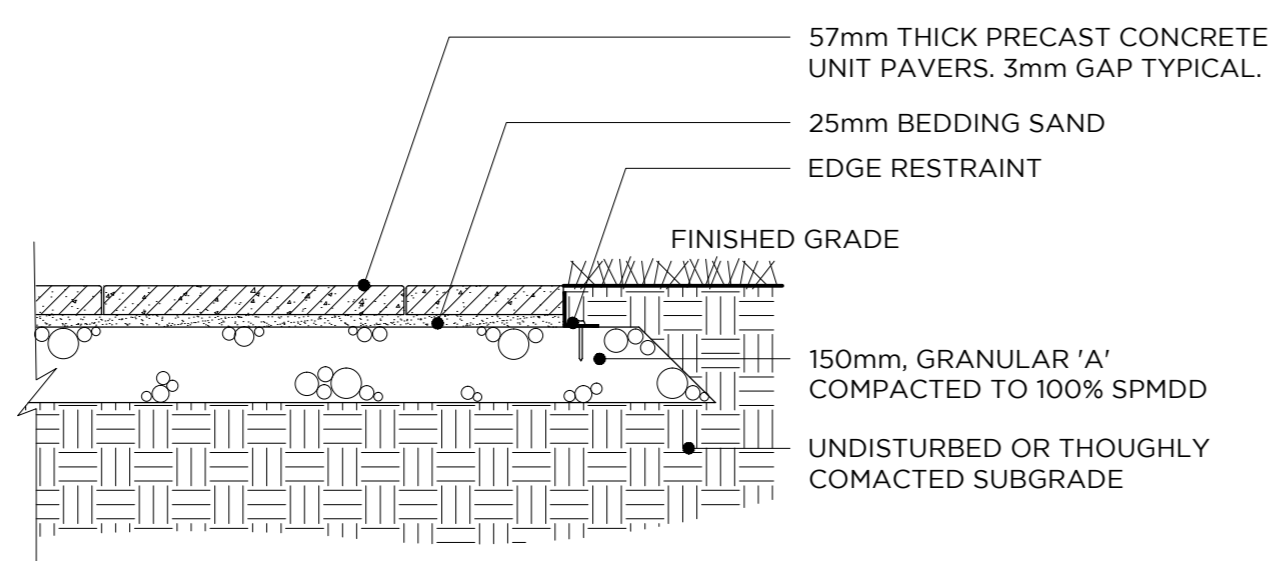

6 | LIGHT DUTY PRECAST CONCRETE PAVERS

LT-6 | 1:15

GENERAL NOTES:

- The General Contractor shall verify all conditions in the field and report any discrepancies to the Landscape Architect prior to construction.
- Any areas outside the limit of work damaged by the General Contractor shall be restored by the General Contractor to the satisfaction of the contract administrator at no additional cost to the Owner.
- All underground utilities to be located by the General Contractor prior to the commencement of any work.
- This drawing is a portion of a complete project and shall be read in conjunction with all other drawings, specifications and tender documents related to the project, regardless of origin.
- All measurements in millimeters unless otherwise noted.
- Do not scale drawing.

7	SUBMITTED FOR SPA REVIEW	2016/07/18
6	SUBMITTED FOR SPA	2016/05/12
5	REVISED FOR REVIEW	2016/06/29
4	REVISED FOR REVIEW	2015/06/05
3	REVISED AS PER COMMENTS	2014/08/19
2	SUBMITTED FOR SPA	2014/04/08
1	FOR REVIEW	2014/03/10
NUMBER	REVISION / REVISION	DATE (MM/DD/YY)

FOTENN



PROJECT / LOCATION / PROJECT / ENDPOINT
RIVERSIDE SOUTH SHOPPING CENTRE
 1420 EARL ARMSTRONG ROAD
 OTTAWA, ONTARIO

DRAWING / DESSIN
DETAILS

DESIGNED BY / CONQUISTAD
 L.M./G.V./E.P.
 DRAWN BY / DESINE PAR
 L.M./G.V./E.P.
 CHECKED BY / VERIFIE PAR
 M.S.
 SCALE / ECHELLE AS SHOWN
L3-1