

# ENVIRONMENTAL IMPACT STATEMENT



210 & 220 MAPLE CREEK COURT, CITY OF OTTAWA, ONTARIO

Project No.: OCP-15-0429

Prepared for:

Mark Kauhanen  
BBS Construction Ltd.  
1805 Woodward Drive  
Ottawa, ON  
K2C 0P9

Prepared by:

McIntosh Perry Consulting Engineers Ltd.  
115 Walgreen Road, R.R.3  
Carp, Ontario  
K0A 1L0

**ENVIRONMENTAL IMPACT STATEMENT  
210 & 220 MAPLE CREEK COURT, CITY OF OTTAWA, ONTARIO**

**Prepared for:**

Mark Kauhanen  
BBS Construction Ltd.  
1805 Woodward Drive  
Ottawa, ON  
K2C 0P9

**Prepared by:**

**McINTOSH PERRY**

McIntosh Perry Consulting Engineers Ltd.  
115 Walgreen Road, R.R.3  
Carp, Ontario  
K0A 1L0

**Version 002  
September 13, 2019**



---

Written by: Erik Pohanka, B. Sc.  
Biologist  
McIntosh Perry Consulting Engineers Ltd.



---

Reviewed by: Matthew Wheeler  
Environmental Planner  
McIntosh Perry Consulting Engineers Ltd.

## TABLE OF CONTENTS

<b>1.0</b>	<b>PROPERTY INFORMATION.....</b>	<b>1</b>
<b>2.0</b>	<b>METHODOLOGY.....</b>	<b>3</b>
<b>3.0</b>	<b>DESCRIPTION OF THE SITE AND THE NATURAL ENVIRONMENT .....</b>	<b>5</b>
3.1	<i>Landforms, Soils, and Geology .....</i>	<i>8</i>
3.2	<i>Surface Water, Groundwater and Fish Habitat.....</i>	<i>8</i>
3.3	<i>Vegetation Cover.....</i>	<i>8</i>
3.4	<i>Wildlife .....</i>	<i>12</i>
3.5	<i>Habitat for Species at Risk.....</i>	<i>13</i>
<b>4.0</b>	<b>DESCRIPTION OF THE PROPOSED PROJECT .....</b>	<b>16</b>
<b>5.0</b>	<b>IMPACT ASSESSMENT .....</b>	<b>18</b>
5.1	<i>Identifying Cumulative Impacts.....</i>	<i>18</i>
<b>6.0</b>	<b>MITIGATION .....</b>	<b>20</b>
<b>7.0</b>	<b>MONITORING .....</b>	<b>22</b>
<b>8.0</b>	<b>SUMMARY AND RECOMMENDATIONS.....</b>	<b>23</b>
<b>9.0</b>	<b>REFERENCES.....</b>	<b>24</b>
<b>10.0</b>	<b>LIMITATIONS .....</b>	<b>26</b>

## LIST OF TABLES

Table 1: Summary of Field Investigations .....	4
Table 2: Vegetation Species List.....	9
Table 3: Wildlife Observations .....	12
Table 4: Species at Risk Potentially Present within the Study Area.....	14

## LIST OF FIGURES

Figure 1: Key Plan.....	2
Figure 2: Natural Features Map .....	6
Figure 3: Constraints and Opportunities Map .....	7
Figure 4: Site Plan.....	17

## APPENDICES





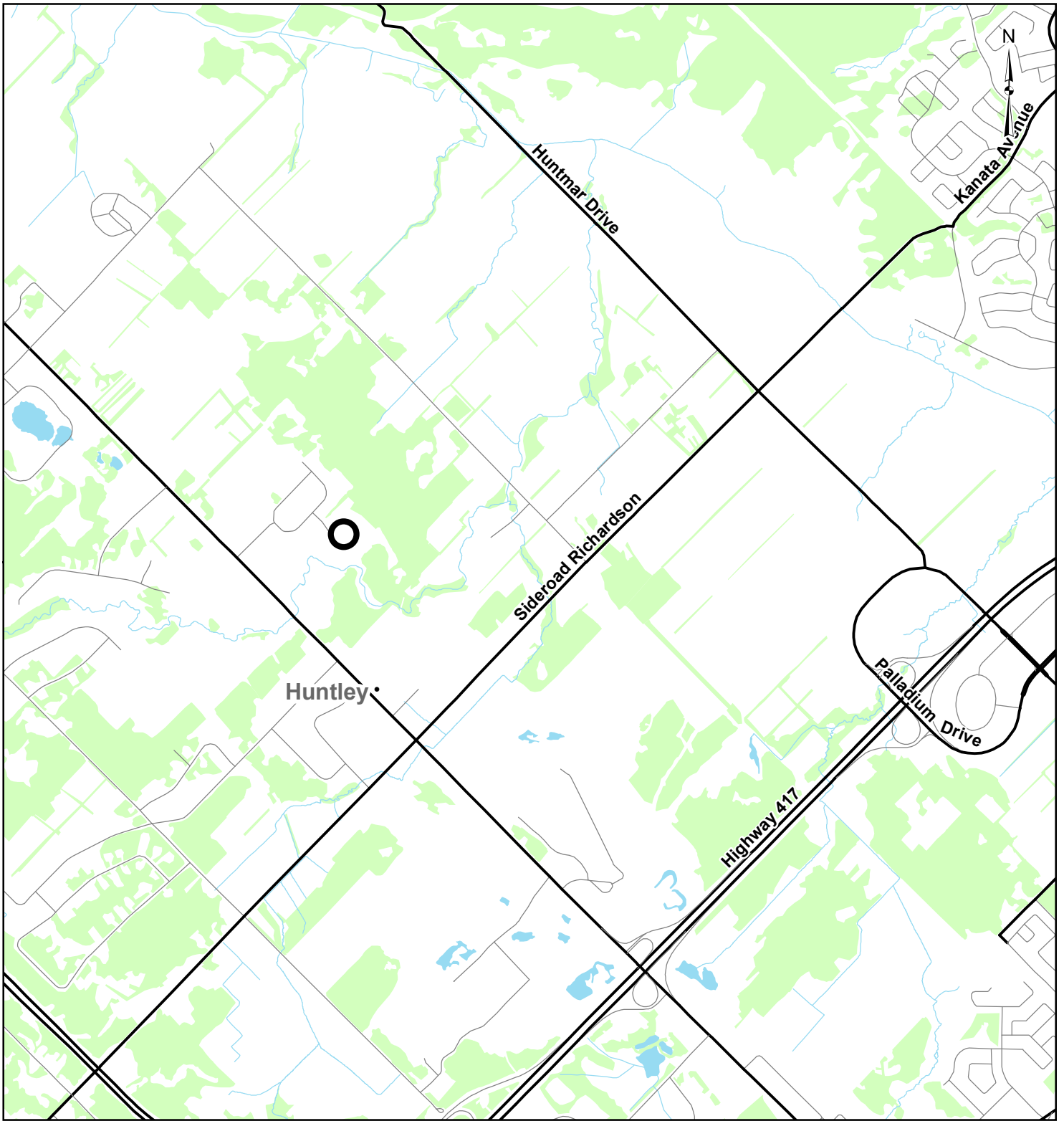

- Appendix A – Photographs
- Appendix B – Native Tree and Shrub Species Appropriate for Plantings
- Appendix C – Clean Equipment Protocol for Industry
- Appendix D – Protocol for Wildlife Protection during Construction

## 1.0 PROPERTY INFORMATION

The subject properties are owned by Mr. Jamie Wall. They are located at 210 and 220 Maple Creek Court, within the approved Reis Road Industrial Park. The properties are described as Parts 4 & 5, Plan 27R-17169 Geographic Township of Huntley, Part Lot 7 Concession 2, City of Ottawa, Property Identification Numbers 045370626 and 045370625. The subject properties cover approximately 3.47 ha and are located at the end of the roundabout on Maple Creek Court. The current planning designation is *Carp Road Corridor Rural Employment Area*. The zoning is *Rural General Industrial (RG5)*.

Based on an analysis of Google Earth and geoOttawa (City of Ottawa, 2019) aerial imagery, historically the subject properties were partially forested, while adjacent lands were utilized for agricultural purposes and also forested. The existing properties are currently undeveloped. The southern lot (220 Maple Creek Court) was initially cleared in 2005 and the northern lot (210 Maple Creek Court) was fully cleared in 2018 under approval by the City of Ottawa. There are no buildings or infrastructure located on or under the existing site.



- LEGEND**
-  Site Location
  -  Local Road
  -  Major Road
  -  Watercourse
  -  Waterbody
  -  Wooded Area



**REFERENCE**  
 GIS Data provided by the Ontario Ministry of Natural Resources and Forestry, 2017.

CLIENT: <b>BBS CONSTRUCTION (ONTARIO) LTD.</b>	
PROJECT: <b>210 MAPLE CREEK COURT</b>	
TITLE: <b>KEY PLAN</b>	
PROJECT NO: CP15-0429	FIGURE: <b>1</b>
Date	Jan., 18, 2017
GIS	JD
Checked By	HL

115 Walgreen Rd., RR#3, Carp, ON K0A1L0  
 Tel: 613-836-2184 Fax: 613-836-3742

Document Path: H:\01 Project - Proposals\2015 Jobs\CP\0CP-15-0429 BBS\_Site Plan\_210 Maple Creek Court\GIS\mxd\CP150429\_01KeyPlan.mxd

## 2.0 METHODOLOGY

In order to satisfy survey requirements outlined in the City of Ottawa's *Environmental Impact Statement Guidelines* (2015a), field investigations were conducted on January 16, 2017, by H. Lunn of McIntosh Perry Consulting Engineers Ltd. (McIntosh Perry) as well as May 14, 2019, by E. Pohanka of McIntosh Perry. The City of Ottawa's *Environmental Impact Statement Guidelines* (2015a) indicates that "site visit(s) will occur during the growing season rather than in winter, when snow cover and normal seasonal dormancy severely limit potential observations." The field investigation on May 14, 2019 was conducted during appropriate growing season.

The field investigations included the following:

- Full walk-through of the proposed development area, and visual observations of adjacent habitat;
- Identification and confirmation of the presence of natural heritage features, including watercourses, water bodies, Provincially Significant Wetlands (PSW), Significant Woodlands and Significant Wildlife Habitat;
- Tree and other plant identification, where site conditions/snow coverage allowed;
- Butternut tree location(s) (if observed);
- Bird and other wildlife identification, and
- Identification and assessment of wildlife habitat, potential breeding, nesting and feeding areas, where site conditions/snow coverage allowed.

Assessed vegetation was classified and mapped using the Ministry of Natural Resources and Forestry's (MNRF) Ecological Land Classification (ELC) vegetation community codes.

Wildlife species noted during the field investigations were identified by signs, visual observations, and vocalizations. For the purpose of this assessment, all wildlife observed within and adjacent to the study limits were recorded and considered to be residents or visitors of the area.

Photographs were taken of the subject property during the field investigations and have been included in **Appendix A** of this report. **Table 1** summarizes the details of the field investigations conducted in the study area.

Table 1: Summary of Field Investigations

Date	Surveyors	Time On Parcel	Temperature	Weather Conditions	Purpose of Visit
January 16, 2017	H. Lunn	8:00 a.m. – 11:00 a.m.	-6 °C	Sunny, moderate wind, no precipitation	Natural features evaluation, species at risk (SAR)/SAR habitat screening, vegetation, and wildlife inventory.
May 14, 2019	E. Pohanka	8:30 a.m. – 10:00 a.m.	6 °C	Overcast, cool, raining, trace amount	Natural features evaluation, species at risk (SAR)/SAR habitat screening (including Bobolink and Eastern Meadowlark, vegetation, and wildlife inventory.







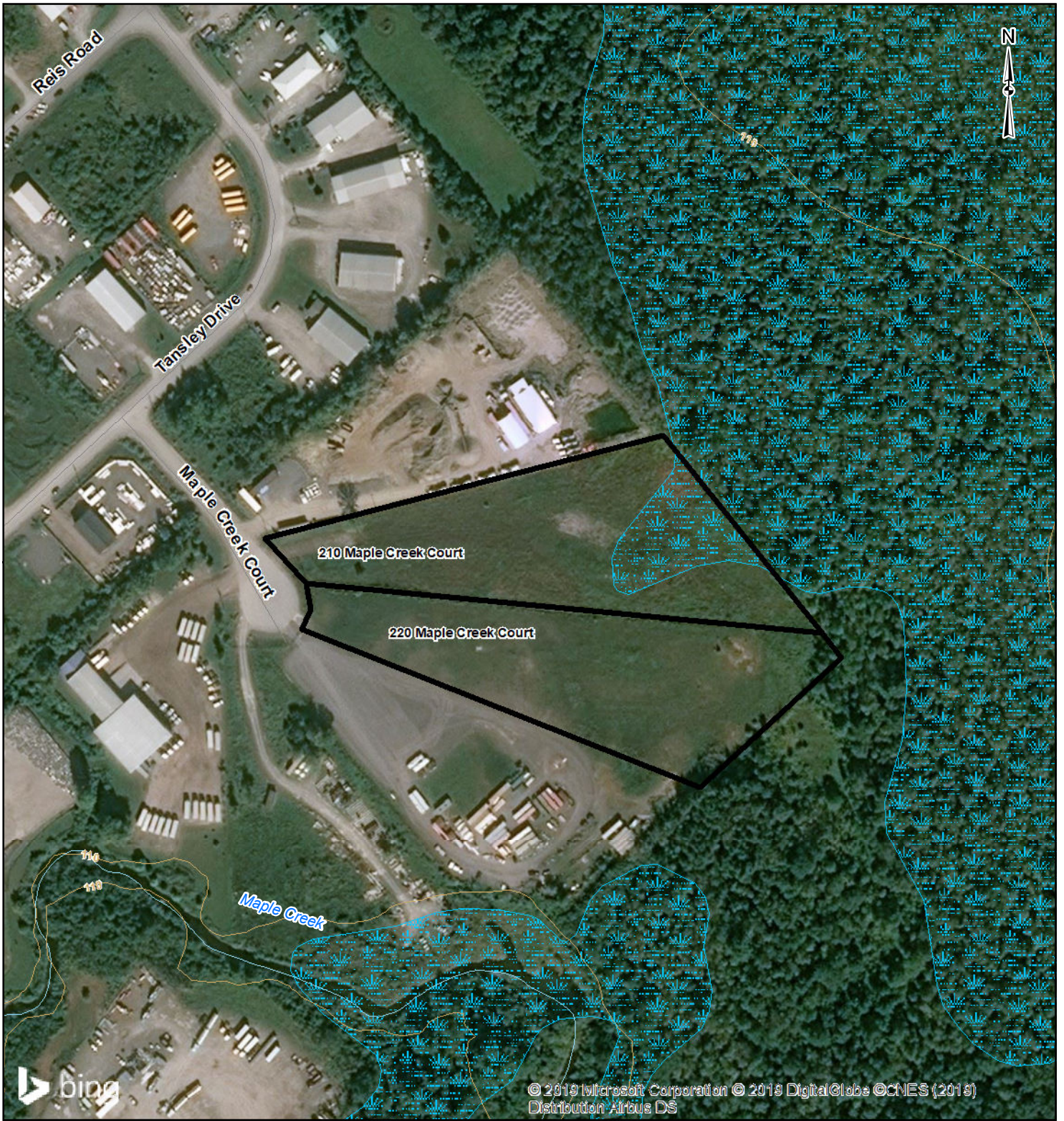

### 3.0 DESCRIPTION OF THE SITE AND THE NATURAL ENVIRONMENT

The following sections (3.1 to 3.5, inclusive), provide a description of the ecological functions provided by the site and identify any functions that contribute to the area being identified as “significant”. **Figure 2 – Natural Features Map** identifies the natural features within and adjacent to the study area based on background information through a desktop review. **Figure 3 – Constraints and Opportunities Map** identifies all terrestrial and aquatic natural features, natural ecosystems, vegetation communities, and potential SAR habitat observed to be present on-site, and adjacent to the site, based on the field investigations. Information provided in the following sections was gathered during the January 16, 2017 and May 14, 2019 field investigations and through background information sources [e.g., Land Information Ontario database (LIO), Atlas of the Breeding Birds of Ontario (ABBO), Ontario Nature’s Ontario Reptile and Amphibian Atlas (ORAA), etc.



**LEGEND**

-  Property Boundary
-  Contour (masl)
-  Local Road
-  Major Road
-  Watercourse
-  Unevaluated Wetland



© 2019 Microsoft Corporation © 2019 DigitalGlobe © CNES (2019)  
Distribution Airbus DS

**REFERENCE**

GIS Data provided by the Ontario Ministry of Natural Resources and Forestry, 2019.



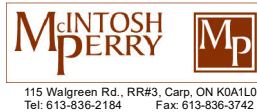





CLIENT:		<b>BBS CONSTRUCTION (ONTARIO) LTD.</b>	
PROJECT:		<b>210 &amp; 220 MAPLE CREEK COURT</b>	
TITLE:		<b>NATURAL FEATURES MAP</b>	
PROJECT NO:	CP15-0429	FIGURE:	<b>2</b>
Date	Sep., 10, 2019		
GIS	SK		
Checked By	EP		



115 Walgreen Rd., RR#3, Carp, ON K0A1L0  
Tel: 613-836-2184 Fax: 613-836-3742



**LEGEND**

- |   |                           |   |                       |
|---|---------------------------|---|-----------------------|
|   | Property Boundary         |  | Cultural Meadow (CUM) |
|  | Red-winged Blackbird Nest |  | Potential Groundwater |
|  | Song Sparrow Nest         |  | Wet Cattail Area      |
|  | Wild Turkey Egg           |  | Wet Horsetail Area    |
|   |                           |  | Significant Woodland  |

**REFERENCE**

GIS Data provided by the Ontario Ministry of Natural Resources and Forestry, 2019.

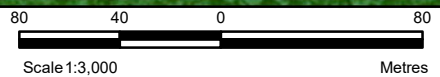

CLIENT:		BBS CONSTRUCTION (ONTARIO) LTD.	
PROJECT:		210 & 220 MAPLE CREEK COURT	
TITLE:		CONSTRAINTS AND OPPORTUNITIES	
PROJECT NO: CP15-0429		FIGURE:	
Date	Sep., 10, 2019	3	
GIS	SK		
Checked By	EP		

**McINTOSH PERRY** 

115 Walgreen Rd., RR#3, Carp, ON K0A1L0  
 Tel: 613-836-2184 Fax: 613-836-3742

### 3.1 Landforms, Soils, and Geology

The general topography of the study area was nearly level. *Soils of the Regional Municipality of Ottawa-Carleton (Excluding the Ottawa Urban Fringe) Ontario Soil Survey Report No. 58* identified the soils on the subject property as from the Jockvale series; fine sandy loam, loamy fine sand, or fine sand (Schut et al., 1987). These soils have imperfect drainage (Schut et al., 1987).

A *Potable Water Supply Assessment* was prepared by Paterson Group Inc. (2017). They concluded that the existing confining nature of the upper bedrock of the aquifer is unlikely to be impacted by contamination or other effects as part of the commercial development. The only potential offsite sources of groundwater contamination identified within the vicinity of the study area are potential spills and road salt use along Maple Creek Court, and the neighbouring waste transfer station.

### 3.2 Surface Water, Groundwater and Fish Habitat

Background information indicated that a watercourse, Maple Creek, is present approximately 120 m south of the subject properties (**Figure 2**). Background information and observations made during the field investigations did not suggest any surface water was present within the subject property.

Though surface water was not observed, Schedule 2 of the City of Ottawa's *Carp Road Corridor Community Design Plan* indicates that the subject property is located in a High Recharge Area. This is an area where surface water is known to infiltrate the ground. In addition, GIS layers from geoOttawa maps (City of Ottawa, 2019) indicate that a portion of the unevaluated wetland has the potential to be present on the property at 210 Maple Creek Court (**Figure 2**). Wetland habitat was not observed on either subject property during the field investigation. However, potential groundwater was observed within the subject property due to iron staining and film on standing water on the south side of the rock fence line between the two subject properties (**Photo 8**). Cattails were present on the north side of the rock fence line (**Photo 7**). A wet area with cattails was also present in the northeast corner of the study area (**Photo 12**). Wet areas with horsetails and phragmites were present in the southeast corner of the study area (**Photos 9 & 10**). These areas were not extensive, and there was no evidence that the unevaluated wetland identified through the LIO database was still present within the study area.

### 3.3 Vegetation Cover

At the time of the January 16, 2017 field investigation, the majority of the subject property at 210 Maple Creek Court was devoid of woody vegetation (**Photos 1 to 3**). Due to the timing of the field investigation, and the amount of snow cover present, a determination of herbaceous vegetation communities using ELC was not possible on this property. Two trees (non-native species), were observed at the west end of the property, closest to Maple Creek Court: Scot's pine (*Pinus sylvestris*) and white fir (*Abies concolor*). No other woody vegetation was present on the 210 Maple Creek Court subject property. Snow cover prevented any observations of herbaceous vegetation on this property.

During the May 14, 2019 field investigation, 210 and 220 Maple Creek Court consisted of a cultural meadow (CUM) with very sparse woody vegetation. Vegetation species composition in the cultural meadow included less than 5% woody species cover. Woody vegetation species observed within the cultural meadow (concentrated within the boundary between the subject properties 210 and 220 Maple Creek Court), included mature speckled alder (*Alnus incana*), shrub willows (*Salix* spp.), common blackberry (*Rubus allegheniensis*) and red-osier dogwood (*Cornus sericea*), and balsam poplar (*Populus balsamifera*) and eastern white cedar (*Thuja occidentalis*) saplings (**Photo 6**). The majority of the woody plants found in the cultural meadow were concentrated along the rock fence line dividing the two subject properties as well as along the south and east boundaries of the study area. The lands adjacent to the northeast and southeast include mixed deciduous forest and swamp. The cultural meadow consisted of a mix of ground cover, grasses, herbaceous wildflower species, and the wetland conditions described in Section 3.2. During the May 14, 2019 field investigation, the study area was surveyed for Butternut (*Juglans cinerea*) and their seedlings. None were observed on or adjacent to the study area.

According to *Vascular Plants of the City of Ottawa, with Identification of Significant Species* (Brunton, 2005), all vegetation species observed on the property and adjacent lands are common in the surrounding area, and none are considered to be rare on the landscape.

A full listing of vegetation species observed on 210 and 220 Maple Creek Court can be found in **Table 2**.

Table 2: Vegetation Species List		
Common Name	Scientific Name	Status According to Brunton (2005)
<b>Trees</b>		
American beech	<i>Fagus grandifolia</i>	Common
balsam poplar	<i>Populus balsamifera</i>	Common
black cherry	<i>Prunus serotina</i>	Common
eastern white-cedar	<i>Thuja occidentalis</i>	Common
green ash	<i>Fraxinus pennsylvanica</i>	Common
ironwood	<i>Ostrya virginiana</i>	Common
red maple	<i>Acer rubrum</i>	Common
Scot’s pine	<i>Pinus sylvestris</i>	Rare (frequently planted)
sugar maple	<i>Acer saccharum</i>	Common
trembling aspen	<i>Populus tremuloides</i>	Common
white birch	<i>Betula papyrifera</i>	Common
white fir	<i>Abies concolor</i>	N/A
white spruce	<i>Picea glauca</i>	Common

Table 2: Vegetation Species List		
Common Name	Scientific Name	Status According to Brunton (2005)
<b>Shrubs</b>		
alternate-leaved dogwood	<i>Cornus alternifolia</i>	Common
common buckthorn	<i>Rhamnus cathartica</i>	Common (aggressive invasive)
glossy buckthorn	<i>Frangula alnus</i>	Common (aggressive invasive)
hawthorn sp.	<i>Crataegus</i> spp.	Unknown (likely common species)
ninebark	<i>Physocarpus opulifolius</i>	Uncommon (plus adventives)
red-osier dogwood	<i>Cornus sericea</i>	Common
riverbank grape	<i>Vitis riparia</i>	Common
shrub willow	<i>Salix</i> spp.	Unknown
speckled alder	<i>Alnus incana</i>	Common
wild red raspberry	<i>Rubus strigosus</i>	Common
<b>Herbaceous Plants</b>		
Aster sp.	Asteraceae	Unknown
black-eyed Susan	<i>Rudbeckia hirta</i>	Common
broad-leaved cattail	<i>Typha latifolia</i>	Common
bull thistle	<i>Cirsium vulgare</i>	Common
coltsfoot	<i>Tussilago farfara</i>	Uncommon (spreading common)
common dandelion	<i>Taraxacum officinale</i>	Common
common evening-primrose	<i>Oenothera biennis</i>	Common
common milkweed	<i>Asclepias syriaca</i>	Common
common mullein	<i>Verbascum thapsus</i>	Common
common scouring-rush	<i>Equisetum hyemale</i>	Common
common yarrow	<i>Achillea millefolium</i>	Common
cow vetch	<i>Vicia cracca</i>	Common
curled dock	<i>Rumex crispus</i>	Common
field pennycress	<i>Thlaspi arvense</i>	Common
goldenrod sp.	<i>Solidago</i> spp.	Unknown
grass sp.	Poaceae	Unknown
ground-ivy / Creeping Charlie	<i>Glechoma hederacea</i>	Common

Common Name	Scientific Name	Status According to Brunton (2005)
hawkweed sp.	<i>Hieracium</i> spp.	Unknown
phragmites	<i>Phragmites australis australis</i>	Uncommon (locally abundant adventive)
Queen Anne's lace	<i>Daucus carota</i>	Common
red clover	<i>Trifolium pratense</i>	Common
sweet white violet	<i>Viola blanda</i>	Common
trout-lily	<i>Erythronium americanum</i>	Common
white sweet-clover	<i>Melilotus alba</i>	Common
wild parsnip	<i>Pastinaca sativa</i>	Common
wild strawberry	<i>Fragaria virginiana</i>	Common

The City of Ottawa identified Significant Woodland as present within the subject properties. The field investigation confirmed that Significant Woodland is not present within either subject property. As noted in Section 1.0 of this report, no forested habitat exists within the subject properties. However, the forested habitat was observed to be present adjacent to the subject properties (northeast and southeast). This habitat is also identified by the City of Ottawa as Significant Woodland (**Figure 2**). Observations of the adjacent forested habitat were made during the field investigations (**Photos 4, 7, 11, 12, 14, & 20**). In addition, recent aerial photography from Google Earth (9/5/2016) was reviewed to determine the character of the historical vegetation community (i.e. within the past 5 years). The City of Ottawa confirmed that the forested habitat adjacent to the subject properties has characteristics of Significant Woodland.

The field investigation confirmed that the adjacent forested habitat consisted of mixed forest and deciduous woodlands. Dominant species observed included: black cherry, green ash, sugar maple, eastern white-cedar, American beech, and ironwood. Google Earth aerial photographs (9/5/2016) depict continuous forest, with interior forest habitat located more than 100 m inside the edge of the forest patch. In addition, GIS layers from geoOttawa maps (City of Ottawa, 2019) show unevaluated wetland habitat and Maple Creek are present within the patch of forest adjacent to the subject properties. These observations and information confirm that the forested habitat adjacent to the subject properties is Significant Woodland. Therefore, the subject properties would be considered to be present on what the *Natural Heritage Reference Manual for Natural Heritage Policies of the Provincial Policy Statement, 2005* (2010) refers to as "Adjacent Lands" (i.e., lands within 120 m of Significant Woodlands where impacts must be considered).

### 3.4 Wildlife

The subject property is located in the St. Lawrence Lowlands Ecozone within the Mixed Plains Ecozone (Crins et al., 2009). Characteristic wildlife within this Ecozone includes black bear, moose, deer, wolf, hare, chipmunk, other small mammals, waterfowl, turtles, snakes, and various bird species. A complete list of wildlife species observed during the field investigations can be found in **Table 3**.

Table 3: Wildlife Observations				
Species Name	Resident/Visitor	Evidence	Abundance on Site	Site Use
<b>Amphibians</b>				
spring peeper ( <i>Pseudacris crucifer</i> )	Visitor	Call	Common	Foraging
<b>Mammals</b>				
coyote ( <i>Canis latrans</i> )	Resident	Tracks	Common	Foraging
red fox ( <i>Vulpes vulpes</i> )	Resident	Tracks	Common	Foraging
white-tailed deer ( <i>Odocoileus virginianus</i> )	Resident	Tracks	Common	Foraging
<b>Birds</b>				
American Crow ( <i>Corvus brachyrhynchos</i> )	Resident	Observed	Common	Flyover
American Goldfinch ( <i>Spinus tristis</i> )	Resident	Call	Common	Foraging
American Redstart ( <i>Setophia ruticilla</i> )	Visitor	Call	Common	Adjacent land
American Robin ( <i>Turdus migratorius</i> )	Visitor	Observed	Common	Foraging
Black-capped Chickadee ( <i>Poecile atricapillus</i> )	Resident	Observed	Common	Adjacent land
Blue Jay ( <i>Cyanocitta cristata</i> )	Resident	Observed	Common	Adjacent land
Canada Goose ( <i>Branta canadensis</i> )	Visitor	Observed	Common	Foraging
Chestnut-sided Warbler ( <i>Setophaga pensylvanica</i> )	Visitor	Observed	Common	Adjacent land
Common Raven ( <i>Corvus corax</i> )	Resident	Call	Common	Foraging
Eastern Phoebe ( <i>Sayornis phoebe</i> )	Visitor	Observed	Common	Foraging



Table 3: Wildlife Observations				
Species Name	Resident/Visitor	Evidence	Abundance on Site	Site Use
Mallard ( <i>Anas platyrhynchos</i> )	Visitor	Observed	Common	Flyover
Ovenbird ( <i>Seiurus aurocapilla</i> )	Visitor	Call	Common	Adjacent land
Red-winged Blackbird ( <i>Agelaius phoeniceus</i> )	Visitor	Observed	Common	Foraging/Nest
Savannah Sparrow ( <i>Passerculus sandwichensis</i> )	Visitor	Observed	Common	Foraging
Song Sparrow ( <i>Melospiza melodia</i> )	Visitor	Observed	Common	Foraging
Turkey Vulture ( <i>Cathartes aura</i> )	Visitor	Observed	Common	Flyover
White-throated Sparrow ( <i>Zonotrichia albicollis</i> )	Visitor	Call	Common	Adjacent land
Wild Turkey ( <i>Meleagris gallopavo</i> )	Resident	Eggs	Common	Nesting habitat
Yellow Warbler ( <i>Setophaga petechia</i> )	Visitor	Call	Common	Adjacent land
Yellow-bellied Sapsucker ( <i>Sphyrapicus varius</i> )	Visitor	Observed	Common	Adjacent land
Yellow-rumped Warbler ( <i>Setophaga coronata</i> )	Visitor	Observed	Common	Adjacent land

Remains of two (2) eggs from Wild Turkeys were observed on the ground within the study area during the May 14, 2019 field investigation (**Photo 20**). This species can breed early in the spring on open ground. It is likely that Wild Turkeys utilized the study area for breeding. Remains of a nest were observed in the cattail area in the northeast corner of the study area during the May 14, 2019 field investigation (**Photo 13**). This nest was most likely constructed by a Red-winged Blackbird in previous years (**Photos 14 & 15**). Another nest was also observed in a shrub willow along the south side of the rock fence line (**Photo 16**). This nest was most likely constructed by Song Sparrows in previous years (**Photo 17**).

### 3.5 Habitat for Species at Risk

Information obtained from background sources (i.e., LIO, ABBO, ORAA), indicated that there was the potential for SAR and SAR habitat to be present on the subject properties. SAR with the potential for habitat to be present on the subject properties are listed below in **Table 4**.

Table 4: Species at Risk Potentially Present within the Study Area

Species Name	Scientific Name	Provincial Status	SAR Habitat Potentially Present on Subject Properties & Adjacent Lands	Source
<b>Bird Species</b>				
Bald Eagle	<i>Haliaeetus leucocephalus</i>	Special Concern	No	ABBO
Bank Swallow	<i>Riparia riparia</i>	Threatened	No	ABBO
Barn Swallow	<i>Hirundo rustica</i>	Threatened	No	ABBO
Black Tern	<i>Chlidonias niger</i>	Special Concern	No	ABBO
Bobolink	<i>Dolichonyx oryzivorus</i>	Threatened	No	LIO
Canada Warbler	<i>Cardellina canadensis</i>	Special Concern	Yes (adjacent forested lands only)	ABBO
Cerulean Warbler	<i>Setophaga cerulea</i>	Threatened	No	ABBO
Chimney Swift	<i>Chaetura pelagica</i>	Threatened	No	ABBO
Common Nighthawk	<i>Chordeiles minor</i>	Special Concern	No	ABBO
Eastern Meadowlark	<i>Sturnella magna</i>	Threatened	No	LIO
Eastern Whip-poor-will	<i>Caprimulgus vociferus</i>	Threatened	No	LIO
Eastern Wood-Pewee	<i>Contopus virens</i>	Special Concern	Yes (adjacent forested lands only)	ABBO
Golden-winged Warbler	<i>Vermivora chrysoptera</i>	Special Concern	No	ABBO
Grasshopper Sparrow	<i>Ammodramus savannarum</i>	Special Concern	No	ABBO
Least Bittern	<i>Ixobrychus exilis</i>	Threatened	No	ABBO
Loggerhead Shrike	<i>Lanius ludovicianus</i>	Endangered	No	LIO
Olive-sided Flycatcher	<i>Contopus cooperi</i>	Special Concern	No	ABBO
Peregrine Falcon	<i>Falco peregrinus</i>	Special Concern	No	ABBO
Red-headed Woodpecker	<i>Melanerpes erythrocephalus</i>	Special Concern	No	ABBO
Short-eared Owl	<i>Asio flammeus</i>	Special Concern	No	ABBO
Wood Thrush	<i>Hylocichla mustelina</i>	Special Concern	Yes (adjacent forested lands only)	ABBO
<b>Vegetation Species</b>				
Butternut	<i>Juglans cinerea</i>	Endangered	Yes (none observed)	LIO
<b>Turtle Species</b>				

Table 4: Species at Risk Potentially Present within the Study Area

Species Name	Scientific Name	Provincial Status	SAR Habitat Potentially Present on Subject Properties & Adjacent Lands	Source
Blanding's Turtle	<i>Emydoidea blandingii</i>	Threatened	Yes (Maple Creek and unevaluated wetlands only)	LIO, ORAA
Snapping Turtle	<i>Chelydra serpentina</i>	Special Concern	Yes (Maple Creek and unevaluated wetlands only)	LIO, ORAA
<b>Mammal Species</b>				
Little Brown Myotis	<i>Myotis lucifugus</i>	Endangered	Yes (adjacent forested lands only)	General range

Potential habitat for the Bobolink, Eastern Meadowlark, and Grasshopper Sparrow was observed to be present within the cultural meadow habitat on the subject property at 220 Maple Creek Court (**Photos 1 to 3**) during the January 16, 2017 field investigation. Due to the time of year in which the field investigation was conducted, confirmation of species presence could not be made. The Bobolink, Eastern Meadowlark, and Grasshopper Sparrow are classified as grassland species. The Bobolink breeds in hayfields and other grasslands with relatively tall vegetation. Eastern Meadowlarks prefer open human-modified landscapes, including hayfields, pastureland, meadows, and other grassland types. The Grasshopper Sparrow prefers drier sites to those of the Bobolink and Eastern Meadowlark. It is found mainly in sparsely vegetated grasslands, with a varying amount of forb and shrub growth. They occasionally are also found in cultivated cereal crop or hay fields. A survey for Bobolink, Eastern Meadowlark, and Grasshopper Sparrow was conducted during the May 14, 2019 field investigation. It was determined that the study area was small and consisted mainly of wildflowers and other non-graminoid herbaceous plants. The study area also included wetland conditions in the east end and wet soils. These conditions were concluded not to be suitable habitat for grassland SAR bird species.

No butternut trees were observed on or within 50 m of the subject property boundaries, during the 2017 and 2019 field investigations. Therefore, it can be concluded that the species is not present at this time within the subject property boundaries or adjacent lands and will not be impacted by the proposed development.

It should be noted that the Significant Woodland (**Figure 2**) on the adjacent property provides potential habitat for the following species: Canada Warbler, Eastern Wood-Pewee, Wood Thrush, and Little Brown Myotis. In addition, the adjacent unevaluated wetland and Maple Creek (**Figure 2**) provide potential habitat for the Snapping Turtle and Blanding's Turtle. Habitat for any of these species was not observed to be present within subject property boundaries as the wetland conditions within the study area were not extensive or provided suitable water depths or vegetation communities. Habitat for all other species listed in **Table 4** was not observed to be present within subject property boundaries or on adjacent lands, during the field investigations.

## 4.0 DESCRIPTION OF THE PROPOSED PROJECT

The proposed development will consist of four (4) warehouse buildings approximately 1,865 m<sup>2</sup> in size. The proposed development will be completed in phases. Parking and drive aisles will be provided throughout the site, with landscaping located around the perimeter of the site. **Figure 3** provides a site plan for the proposed development.

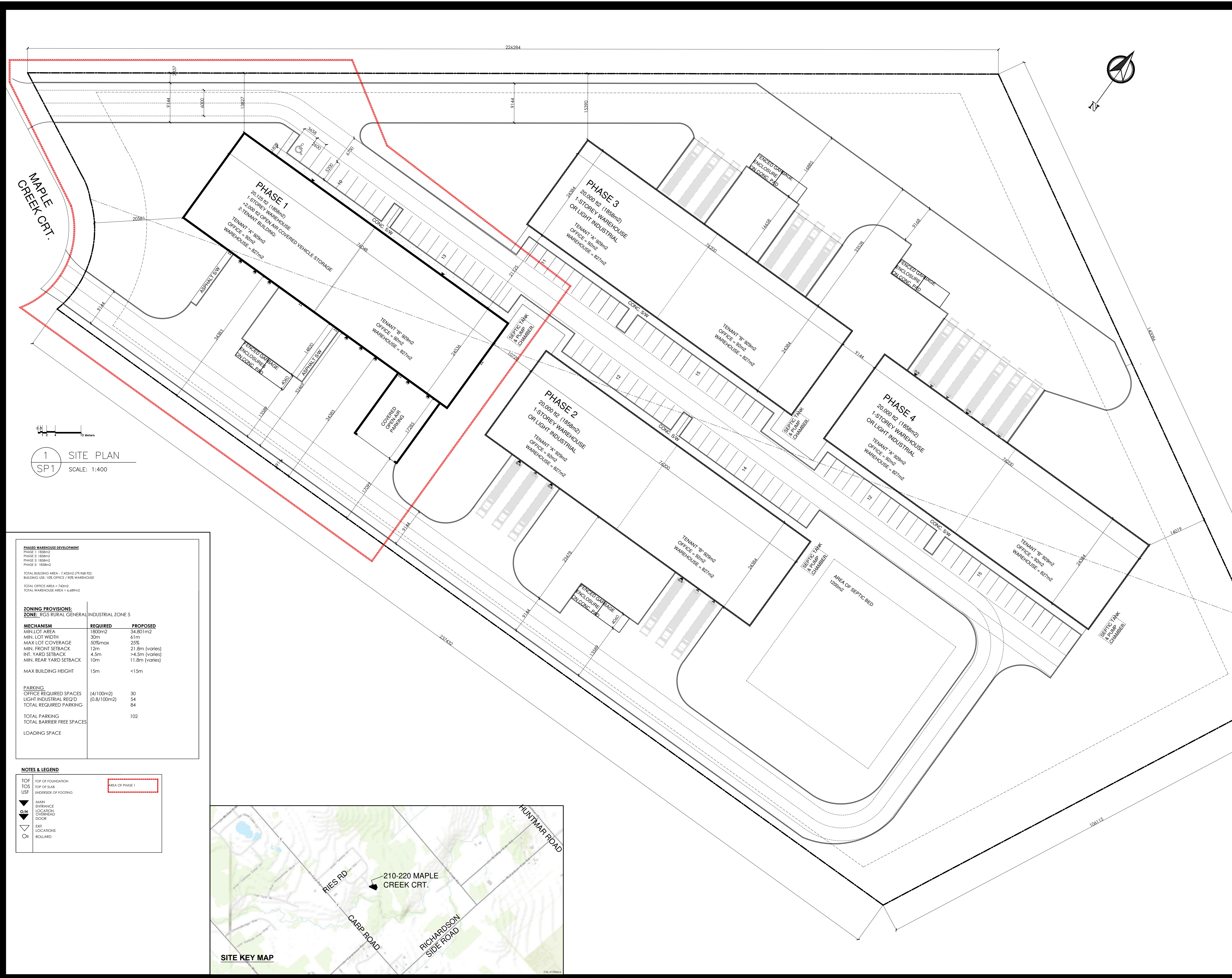

1 SITE PLAN  
SP1 SCALE: 1:400

**PHASED WAREHOUSE DEVELOPMENT**

PHASE 1: 1859m<sup>2</sup>  
PHASE 2: 1859m<sup>2</sup>  
PHASE 3: 1859m<sup>2</sup>  
PHASE 4: 1859m<sup>2</sup>

TOTAL BUILDING AREA = 7,436m<sup>2</sup> (79,848 SQ FT)  
BUILDING USE: 10% OFFICE / 90% WAREHOUSE  
TOTAL OFFICE AREA = 743m<sup>2</sup>  
TOTAL WAREHOUSE AREA = 6,693m<sup>2</sup>

ZONING PROVISIONS:		
ZONE: RGS RURAL GENERAL INDUSTRIAL ZONE 5		
MECHANISM	REQUIRED	PROPOSED
MIN. LOT AREA	1800m <sup>2</sup>	24,801m <sup>2</sup>
MIN. LOT WIDTH	30m	61m
MAX. LOT COVERAGE	50% max	25%
MIN. FRONT SETBACK	12m	21.8m (varies)
INT. YARD SETBACK	4.5m	>4.5m (varies)
MIN. REAR YARD SETBACK	10m	11.8m (varies)
MAX. BUILDING HEIGHT	15m	<15m

PARKING		
OFFICE REQUIRED SPACES	(4/100m <sup>2</sup> )	30
LIGHT INDUSTRIAL REQ'D	(0.8/100m <sup>2</sup> )	54
TOTAL REQUIRED PARKING		84
TOTAL PARKING		102
TOTAL BARRIER FREE SPACES		
LOADING SPACE		

**NOTES & LEGEND**

TOF	TOP OF FOUNDATION	
TOS	TOP OF SLAB	
USF	UNDERSIDE OF FOOTING	AREA OF PHASE 1
ENT	ENTRANCE	
LOC	LOCATION	
OVH	OVERHEAD	
DOOR	DOOR	
EXIT	EXIT LOCATIONS	
BOLL	BOLLARD	

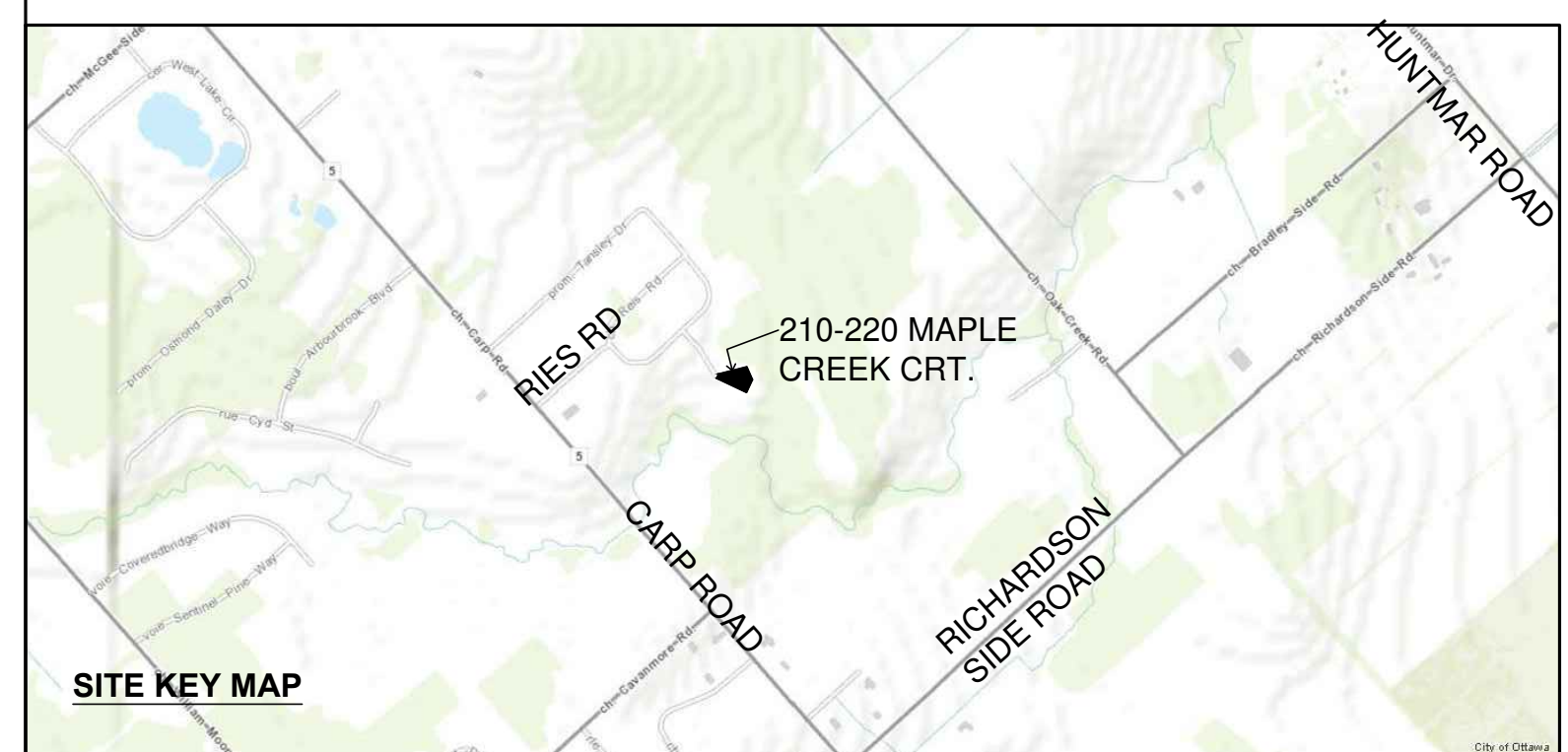

REVISION		
NO.	DATE	REVISION
1		
2		
3		
4		
5		

CIVIL / SURVEYOR:  
  
 ARCHITECT:

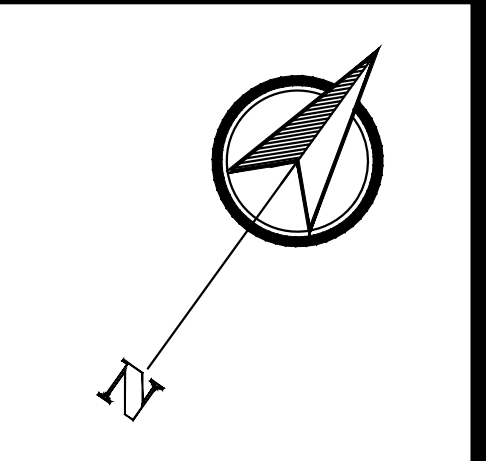

**BBS**  
 BUILDING A REPUTATION ON EXCELLENCE  
 BBS CONSTRUCTION (ONTARIO) LTD.  
 1805 WOODWARD DRIVE,  
 OTTAWA, ON K2C 0P9  
 TEL: 613-226-8830 FAX: 613-226-7709  
 www.bbsconstruction.ca

**wall**  
 sound-lighting-staging  
 WALL SOUND  
 2434894 Ontario Inc.

PROJECT:  
 WALL SOUND - PHASED  
 OFFICE / WAREHOUSE PROJECT  
 210 / 220 MAPLE CREEK COURT

DRAWING TITLE:  
 SITE PLAN

PROJECT N°: 397-16

SCALE: AS NOTED

DRAWN BY: MK

DATE: 24/10/2016

DRAWING NO.

**SP1**

## 5.0 IMPACT ASSESSMENT

It is not anticipated that the proposed development will have a significant negative impact on terrestrial vegetation present on the subject property. The proposed development is located within an industrial park, within cultural meadows and previously cleared areas, which do not appear to contain sensitive, rare or significant vegetation species. In addition, there is less than 5 % woody vegetation coverage on the subject properties, and vegetation species observed are considered common in the area.

Based on the current site plan, negative impacts that could occur to the adjacent Significant Woodland as a result of the proposed development include effects such as the introduction of invasive species and damage to root systems/critical root zone of trees. The site plan (**Figure 3**) depicts one area where the pavement is proposed to be placed within 1.54 m of the edge of the Significant Woodland. The remaining development maintains a 10 m or greater buffer from the Significant Woodland edge. Development in close proximity to the Significant Woodland may cause the introduction of non-native and/or invasive species into this habitat. In addition, development this close to mature trees may cause negative impacts to the critical root zone of trees directly adjacent to the area. Aside from the select trees directly adjacent to the proposed development, overall habitat within the Significant Woodland is not anticipated to be negatively impacted by the proposed development.

The subject properties currently provide foraging habitat for common mammals and birds within the area (e.g., red fox, white-tailed deer, Savannah Sparrow, etc.) as well as nesting habitat for Wild Turkeys. The few trees, shrubs and cultural meadow habitat found on the subject properties also provide nesting habitat for migratory birds during the breeding/nesting season from April 1 to September 5 of any year. The development will remove a small amount of these types of habitat from the surrounding area. Mitigation measures are outlined in Section 6.0 to avoid impacts to wildlife species during construction.

It is not anticipated that SAR will be impacted as part of the project works due to the lack of Butternut presence and that the study area does not provide suitable habitat for SAR grassland birds. However, SAR bird and bat habitat potentially present in the adjacent Significant Woodlands may be impacted due to the placement of pavement within 1.54 m of this habitat. The Eastern Wood-pewee may be impacted if present, due to their preference for edge habitats. However, the Eastern Wood-pewee does not receive habitat protection and it was not observed to be present during field surveys.

### 5.1 Identifying Cumulative Impacts

It is recommended that the current site plan be re-evaluated to accommodate the existing critical root zone of adjacent trees within the Significant Woodland, in order to prevent cumulative impacts to this feature through the loss of mature trees. If this can be accommodated, then by following the recommended mitigation measures outlined in Section 6.0 of this report, cumulative impacts should be avoided to the Significant Woodland. Alternatively, the critical root zones of the trees that have the potential to be impacted by the current site plan

could be determined, and their loss could be off-set by re-planting additional native tree species elsewhere on the property. A list of suitable species can be found in **Appendix B**.

## 6.0 MITIGATION

In order to minimize or eliminate environmental impacts from construction and development, the following mitigation measures are recommended:

- To prevent the introduction and spread of invasive plant species into the site and adjacent Significant Woodland, equipment utilized during construction should be inspected and cleaned in accordance with the *Clean Equipment Protocol for Industry* (**Appendix C**);
- In order to prevent negative impacts to the adjacent Significant Woodland and the sensitive habitat present within, it is recommended that a vegetated buffer be maintained, at minimum, within the critical root zone of trees along the woodland edge, between the proposed development and the adjacent Significant Woodland. Planting native species within this buffer and all associated “landscaped” areas is encouraged, as they will be better adapted to the local site conditions and provide a contributory function to the Significant Woodland located adjacent to the subject property. A list of suitable species can be found in **Appendix B**;
- In accordance with Appendix 10 of the *Environmental Impact Statement Guidelines* for the City of Ottawa, no clearing of any vegetation should occur between April 1 and September 5, unless a qualified biologist has determined that no nesting is occurring within 5 days prior to the clearing. Note: these dates are based upon breeding bird nesting data for eastern Ontario, provided by Bird Studies Canada (Hussell and Lepage, 2019). The nests and eggs of many species are protected under the federal and/or provincial legislation (i.e., *Migratory Birds Convention Act, Fish, and Wildlife Conservation Act*);
- In accordance with the *Protocol for Wildlife Protection during Construction* (**Appendix D**), reduce potential wildlife usage of the cultural meadow habitat (**Figure 2**) by mowing outside of the breeding season (i.e., before April 1), then maintain as mowed grass until on-site work begins;
- Should any SAR be discovered throughout the course of the work, and/or should any SAR or their habitat be potentially impacted by on-site activities, the Ministry of Environment, Conservation, and Parks (MECP) should be contacted immediately and operations modified to avoid any negative impacts to SAR or their habitat, until further direction is provided by the MECP;
- In accordance with recommendations regarding trees and woodlands found in Appendix 10 of the *Environmental Impact Statement Guidelines* for the City of Ottawa, the following mitigation measures should be employed to avoid negative impacts to the trees present within the adjacent Significant Woodland:
  - Erect a fence at the outer limit of the critical root zone (CRZ) of trees on the edge of the Significant Woodland. The CRZ is defined as the distance around the tree at a radius of 10 times the diameter of the tree (at breast height);
  - Do not place any material or equipment within the CRZ of the trees on the edge of the Significant Woodland;
  - Do not attach any signs, notices or posters to any tree;



- Do not raise or lower the existing grade within the CRZ of the trees on the edge of the Significant Woodland without approval from the City of Ottawa;
- Tunnel or bore when digging within the CRZ of the trees on the edge of the Significant Woodland, and
- Ensure that exhaust fumes from all equipment are not directed towards any tree's canopy on the edge of the Significant Woodland.

## 7.0 MONITORING

At this time, there are no recommended monitoring requirements for the site. However, standard daily monitoring should be conducted within the construction areas prior to work start-up, to ensure no wildlife or SAR will be impacted.

## 8.0 SUMMARY AND RECOMMENDATIONS

Negative impacts on vegetation and wildlife species present on the subject property can be moderated by implementing the recommended mitigation measures found in Section 6.0 of this report. Given the current site plan, minor negative impacts are anticipated to select mature trees at the periphery of the Significant Woodland where the proposed development is to occur within 1.54 m of the woodland edge. If the site plan is not amended to accommodate these trees, the critical root zones of these trees could be determined, and their loss could be off-set by re-planting additional native tree species elsewhere on the property. Impacts on SAR are not anticipated as part of the current site plan.

## 9.0 REFERENCES

- Bird Studies Canada, Environment Canada's Canadian Wildlife Service, Ontario Nature, Ontario Field Ornithologists, and Ontario Ministry of Natural Resources (OBBA). 2006. *Atlas Data Summary*. Ontario Breeding Bird Atlas Website. 31 January 2008. <http://www.birdsontario.org/atlas/index.jsp>. Accessed 13 August 2019.
- Brunton, D. 2005. *Vascular Plants of the City of Ottawa, with the Identification of Significant Species*. City of Ottawa. [http://ottawa.ca/calendar/ottawa/citycouncil/ec/2005/05-24/AppendixA%20-%20OTTAWA%20FLORA%20\(APR%2005\).htm](http://ottawa.ca/calendar/ottawa/citycouncil/ec/2005/05-24/AppendixA%20-%20OTTAWA%20FLORA%20(APR%2005).htm). Accessed 13 August 2019.
- City of Ottawa. 2003. *Official Plan*. City of Ottawa.
- City of Ottawa. 2004. *Carp Road Corridor Community Design Plan*. City of Ottawa.
- City of Ottawa. 2015a. *Environmental Impact Statement Guidelines*. Planning and Growth Management. City of Ottawa. 79 p.
- City of Ottawa. 2015b. *Protocol for Wildlife Protection during Construction. Planning and Growth Management*. City of Ottawa. 17 p.
- City of Ottawa. 2019. *geoOttawa*. Teranet Enterprises Inc. <http://maps.ottawa.ca/geoottawa/>. Accessed 18 January 2017.
- Crins, W.J., P.A. Gray, P.W.C. Uhlig, and M.C. Wester. 2009. *The Ecosystems of Ontario, Part 1: Ecozones and Ecoregions*. Inventory, Monitoring and Assessment Section. Science and Information Branch. Ontario Ministry of Natural Resources. Ontario, Canada: Queen's Printer for Ontario. 87p.
- Ecological Stratification Working Group. 1996. *A National Ecological Framework for Canada*. Agriculture and Agri-Food Canada, Research Branch, Centre for Land and Biological Resources Research, and Environment Canada. State of the Environment Directorate; Ecozone Analysis Branch, Ottawa/Hull.
- Endangered Species Act*. 2007. S.O. 2007, c. 6. Current version 30 June 2008.
- Fish and Wildlife Conservation Act*. 1997. S.O. 1997, c. 41. Current version 08 March 2018.
- Hussell, J. and D. Lepage. 2015. *Bird Nesting Calendar Query Tool. Project NestWatch*. Bird Studies Canada. <http://www.birdscanada.org/volunteer/pnw/rnest/warning.jsp?lang=en>. Accessed 13 August 2019.
- Lee, HT, WD Bakowsky, J Riley, J Bowles, M Puddister, P Uhlig and S McMurray. 1998. *Ecological Land Classification for Southern Ontario: First Approximation and its Application*. Ontario Ministry of Natural Resources, South Central Science Section, Science Development and Transfer Branch. SCSS Field Guide FG-02.
- Migratory Birds Convention Act*. 1994. S.C. 1994, c. 22. Current version 14 February 2019.

Ministry of Municipal Affairs and Housing. 2014. *Provincial Policy Statement*. Queen's Printer of Ontario. 50 p.

Ministry of Natural Resources and Forestry (MNRF). 2014. *Make A Map: Natural Heritage Areas*. Ministry of Natural Resources and Forestry. [http://www.gisapplication.lrc.gov.on.ca/mamnh/Index.html?site=MNR\\_NHLUPS\\_NaturalHeritage&viewer=NaturalHeritage&locale=en-US](http://www.gisapplication.lrc.gov.on.ca/mamnh/Index.html?site=MNR_NHLUPS_NaturalHeritage&viewer=NaturalHeritage&locale=en-US). Queen's Printer for Ontario. Accessed 16 July 2019.

Ministry of Natural Resources and Forestry (MNRF). 2018. *Land Information Ontario metadata tool*. <https://www.ontario.ca/page/land-information-ontario>. Queen's Printer of Ontario. Accessed 16 July 2019.

Ontario Ministry of Natural Resources. March 2010. *Natural Heritage Reference Manual for Natural Heritage Policies of the Provincial Policy Statement, 2005*. Second Edition. Toronto: Queen's Printer for Ontario. 248 p.

Paterson Group Inc. 2017. *Potable Water Supply Assessment: Commercial Site Development 210 and 220 Maple Creek Court Ottawa, Ontario*. Paterson Group Inc. 101 p.

Provincial Policy Statement. 2012. Toronto: Ministry of Municipal Affairs and Housing.

Schut, L.W. and E.A. Wilson. 1987. *Soils of the Regional Municipality of Ottawa-Carleton (Excluding the Ottawa Urban Fringe) Ontario Soil Survey Report No. 58*. Agriculture Canada & Ministry of Agriculture and Food Ontario.

## 10.0 LIMITATIONS

The investigations undertaken by McIntosh Perry with respect to this report and any conclusions or recommendations made in this report reflect McIntosh Perry's judgment based on the site conditions observed at the time of the site inspection on the date set out in this report, and on information available at the time of the preparation of this report.

This report has been prepared for specific application to this site and it is based, in part, upon visual observation of the site, and terrestrial investigations at various locations during a specific time interval, as described in this report. Unless otherwise stated, the findings cannot be extended to previous or future site conditions, or portions of the site which were unavailable for direct investigation.

If site conditions or applicable standards change or if any additional information becomes available at a future date, modifications to the findings, conclusions and recommendations in this report may be necessary.

If you have any question, comments, or concerns, please do not hesitate to contact the undersigned at McIntosh Perry at 613-203-5470.

Sincerely,  
McIntosh Perry Consulting Engineers Ltd.



---

Erik Pohanka, B. Sc.  
Biologist

## Appendix A – Photographs



Photo 1: Subject property at 210 Maple Creek Court in winter conditions, facing east. 16 January 2017.



Photo 2: Subject properties at 210 and 220 Maple Creek Court in winter conditions, facing southeast. 16 January 2017.





**Photo 3: Subject properties at 210 and 220 Maple Creek Court in winter conditions, facing west towards Maple Creek Court. 16 January 2017.**



**Photo 4: Subject property at 220 Maple Creek Court in spring conditions, facing east. 14 May 2019.**



Photo 5: Subject property at 210 Maple Creek Court in spring conditions, facing west. 14 May 2019.



Photo 6: Subject property at 210 Maple Creek Court (left), subject property at 220 Maple Creek Court (right) and rock fence line (middle), facing east. 14 May 2019.



**Photo 7: Wet cattail area on north side of rock fence line and shrub area on south side of rock fence line, facing east.  
14 May 2019.**



**Photo 8: Iron staining and film on standing water suggesting potential ground water on south side of rock fence line.  
14 May 2019.**



**Photo 9: Wet horsetail area in southeast corner of study area, facing southeast. 14 May 2019.**



**Photo 10: Wet phragmites area in southeast corner of study area, facing east. 14 May 2019.**



**Photo 11: Mixed deciduous forest adjacent to the northeast and southeast sides of the study area. 14 May 2019.**



**Photo 12: Wet cattail area in the northeast corner of the study area. 14 May 2019.**



Photo 13: Old Red-winged Blackbird (*Agelaius phoeniceus*) nest in the cattail area in the northeast corner of the study area. 14 May 2019.



Photo 14: Female Red-winged Blackbird (*Agelaius phoeniceus*) present in the edge of the mixed deciduous forest adjacent to the east side of the study area. 14 May 2019.



Photo 15: Male Red-winged Blackbird (*Agelaius phoeniceus*) along the stone fence line within the study area. 14 May 2019.



Photo 16: Song Sparrow (*Melospiza melodia*) nest in a shrub willow along the stone fence line within the study area. 14 May 2019.



Photo 17: Song Sparrow (*Melospiza melodia*) present within the study area. 14 May 2019.



Photo 18: Savannah Sparrow (*Passerculus sandwichensis*) present within the study area. 14 May 2019.





Photo 19: Canada Goose (*Branta canadensis*) present within the study area. 14 May 2019.



Photo 20: Eastern Phoebe (*Sayornis phoebe*) present in the edge of the mixed deciduous forest adjacent to the east side of the study area. 14 May 2019.



Photo 21: One of two Wild Turkey (*Meleagris gallopavo*) eggs found on the ground within the study area. 14 May 2019.



Photo 22: White-tailed deer (*Odocoileus virginianus*) tracks found in the study area. 14 May 2019.

## **Appendix B – Native Tree and Shrub Species Appropriate for Planting**

Native Tree and Shrub Species Appropriate for Planting			
Common Name	Latin Name	Plant Description	Growing Conditions
<b>Tree Species</b>			
eastern white-cedar	<i>Thuja occidentalis</i>	<ul style="list-style-type: none"> <li>• up to 15 m in height</li> <li>• excellent windbreaker when planted in buffer strips</li> </ul>	Full sun to partial shade; shallow, moist or dry, non-acidic soil; tolerant of flooding
sugar maple	<i>Acer saccharum</i>	<ul style="list-style-type: none"> <li>• up to 35 m in height</li> </ul>	Prefers deep, rich, moist soil; can tolerate shade but grows better in full sun
black cherry	<i>Prunus serotina</i>	<ul style="list-style-type: none"> <li>• up to 22 m in height</li> </ul>	Tolerates different moisture levels and a variety of soils; full sun
<b>Shrub Species</b>			
speckled alder	<i>Alnus incana</i>	<ul style="list-style-type: none"> <li>• up to 6 m in height</li> <li>• habitat for nesting migratory birds</li> <li>• food source for birds</li> </ul>	Various soil types; tolerant of flooding, full sun to partial shade
red-osier dogwood	<i>Cornus sericea</i>	<ul style="list-style-type: none"> <li>• 1 to 2 m in height</li> <li>• valuable wildlife food</li> </ul>	Moist soil; tolerant of flooding, full sun to partial shade

## **Appendix C – Clean Equipment Protocol for Industry**

# Clean Equipment Protocol for Industry

Inspecting and cleaning equipment for the purposes of invasive species prevention



Invasive  
Species  
Centre

*Catalyst for research and response*



Ontario



Ontario  
Invasive Plant Council

Publication Information

Halloran, Joe, Anderson, Hayley and Tassie, Danielle. 2013. Clean Equipment Protocol for Industry. Peterborough Stewardship Council and Ontario Invasive Plant Council. Peterborough, ON.

Printed April 2013  
Peterborough, Ontario

ISBN: (to be confirmed)

This document was prepared for the Canada-Ontario Invasive Species Centre and the Ontario Ministry of Natural Resources by the Peterborough Stewardship Council and the Ontario Invasive Plant Council.

Inquiries regarding this document can be directed to the Ontario Invasive Plant Council  
PO Box 2800, 4601 Guthrie Drive  
Peterborough, ON  
K9J 8L5

Phone: (705) 748-6324  
Email: [info@ontarioinvasiveplants.ca](mailto:info@ontarioinvasiveplants.ca)

For more information on invasive plants in Ontario, visit [www.ontario.ca/invasivespecies](http://www.ontario.ca/invasivespecies),  
[www.ontarioinvasiveplants.ca](http://www.ontarioinvasiveplants.ca), [www.invadingspecies.com](http://www.invadingspecies.com) or [www.invasivespeciescentre.ca](http://www.invasivespeciescentre.ca)

# Table Of Contents

<b>Introduction .....</b>	<b>1</b>
<b>Why Cleaning Vehicles and Equipment is Important .....</b>	<b>3</b>
<b>Impacts of Invasive Species on Industry .....</b>	<b>4</b>
Construction .....	4
Forestry/Agriculture .....	4
Land Management (Trail Use/Maintenance).....	4
Roadsides/Utilities .....	4
<b>Steps to Prevent the Unintentional Introduction of Invasive Species from Equipment .....</b>	<b>5</b>
When to Inspect .....	5
How to Inspect .....	5
When to Clean.....	6
Where to Clean .....	6
How to Clean Inside .....	6
How to Clean Outside .....	6
<b>Final Inspection Checklist .....</b>	<b>7</b>
Equipment Required .....	7
<b>Inspection and Cleaning Diagrams and Checklists .....</b>	<b>8</b>
2WD and 4WD Vehicles.....	8
Excavator .....	9
Backhoe.....	10
Bulldozer .....	11
<b>Contacts and Resources .....</b>	<b>12</b>
<b>Appendix A: Identification of Invasive Plants found in Ontario .....</b>	<b>13</b>



# Introduction

## Why Invasive Plants are a Problem

Invasive alien species are “a growing environmental and economic threat to Ontario. Alien species are plants, animals and microorganisms that have been accidentally or deliberately introduced into areas beyond their normal range. Invasive species are defined as harmful alien species whose introduction or spread threatens the environment, the economy, or society, including human health (Government of Canada 2004).” (Ontario Invasive Species Strategic Plan, 2012). The great majority of plant invasions occur in habitats that have been disturbed either naturally or by humans (Rejmanek 1989; Hobbs and Huenneke 1992; Hobbs 2000).

The ecological effects of invasive species are often irreversible and, once established, they are extremely difficult and costly to control or eradicate. According to Pimental et al. (1999), invasive species in the U.S. cause economic and environmental damages totalling over \$138 billion per year, with agricultural weed control and crop losses totalling approximately \$34 billion per year. Exact figures for the total economic and environmental damages are not available for Canada. In Ontario however, the costs of dealing with just one invasive species is astonishing; Zebra Mussels cost Ontario power producers who draw water from the lake \$6.4 million per year in increased control/operating costs and about \$1 million per year in research costs (Colautti et al. 2006).

Invasive species can spread to new areas when contaminated mud, gravel, water, soil and plant material are unknowingly moved by equipment used on different sites. This method of spread is called an unintentional introduction, and is one of the four major pathways for invasive species introduction into a new area of Ontario (Ontario Invasive Species Strategic Plan, 2012).



**Buckthorn removal, Lynde Shores Conservation Area.**  
Photo by: Central Lake Ontario Conservation Authority

Invasive plant seed and propagules (plant material, i.e. rhizomes) have the ability to travel sight unseen in mud attached to or lodged in various parts and spaces between parts of vehicles, machinery and other mechanical equipment. A recent study at Montana State University found that most seeds (99% on paved roads and 96% on unpaved roads) stayed attached to the vehicle after traveling 160 miles (257 km) under dry conditions.

Invasive plant species are commonly transported on or in vehicles and construction equipment when they are moved to new locations. Those vehicles include four-wheel drives, excavators, tractors, loaders, water trucks and all-terrain vehicles. Failure to properly clean vehicles and machinery of soils, mud, and contaminated water that may contain invasive species seed and propagules can result in permanent, irreversible environmental impacts. These impacts can mean substantial cost to the landowner, land manager and/or the user. Businesses may also face liability issues for activities and operations that result in the introduction of invasive species.

Some of the invasive species in Ontario which have been known to spread through equipment transfer include:

- **Common Buckthorn** (*Rhamnus cathartica*)
- **Dog-strangling Vine** (*Cynanchum rossicum*)
- **Garlic Mustard** (*Alliaria petiolata*)
- **Giant Hogweed** (*Heracleum mantegazzianum*)
- **Glossy Buckthorn** (*Frangula alnus*)
- **Japanese Knotweed** (*Polygonum cuspidatum*)
- **Miscanthus or Chinese Silver Grass** (*Miscanthus sinensis*)
- **Phragmites or Common Reed** (*Phragmites australis* subsp. *australis*)
- **Reed Canary Grass** (*Phalaris arundinacea*)
- **Wild Parsnip** (*Pastinaca sativa*)
- **Wild Chervil** (*Anthriscus sylvestri*)



**Dog-strangling vine**  
(*Cynanchum rossicum*)  
Photo by: Hayley Anderson



**Garlic Mustard**  
(*Alliaria petiolata*)  
Photo by: Ken Towle



**Phragmites**  
(*Phragmites australis* subsp. *Australis*)  
Photo by: Michael Irvine

These plants impact biodiversity by out-competing native species for space, sunlight, and nutrients. They can also have impacts on road and driver safety by physically blocking intersection sightlines, and in the case of Phragmites and Miscanthus, may fuel intense grass fires if ignited, which can damage utility stations and hydro lines.

**The harmful effects of invasive species include:**

- Physical and structural damage to infrastructure
- Human health hazards (i.e. Giant Hogweed and Wild Parsnip exposure)
- Delays and increased cost in construction activities
- Environmental damage (i.e. erosion)
- Aesthetic degradation
- Loss of biodiversity
- Reduced property values
- Loss of productivity in woodlots and agriculture

# Why Cleaning Vehicles and Equipment is Important

Passenger and recreational vehicles as well as heavy machinery are major vectors for spreading terrestrial invasive species into new areas.

It is much more costly to control invasive species after their establishment and spread than it is to prevent their spread. The spread of invasive species through unintentional introduction can be minimized significantly by the diligent cleaning of vehicles and equipment when leaving one site and moving to the next. In the case of large properties, cleaning before moving to a new site is recommended, even if it is within the same property.

This guide has been developed for the construction, agriculture, forestry and other land management industries, to provide equipment operators and practitioners with tools and techniques to identify and prevent the unintentional introduction of invasive species. It establishes a standard for cleaning vehicles and equipment and provides a guide where current codes of practice, industry standards or other environmental management plans are not already in place.

---

## Passenger and recreational vehicles include:

- 2WD and 4WD cars
- 2WD and 4WD trucks
- All Terrain Vehicles (ATV's)
- Motorbikes
- Snowmobiles

## Heavy machinery includes:

- Trucks
- Tractors
- Mowers
- Slashers
- Trailers
- Backhoes
- Graders
- Dozers
- Excavators
- Skidders
- Loaders
- Water Tankers and Trucks



**Dog-strangling Vine plants attached to ATV.**  
Photo by: Francine Macdonald



**Plant material attached to bobcat.**  
Photo by: TH9 Outdoor Services

# Impacts of Invasive Species on Industry

## Construction

In the UK, Japanese Knotweed (*Polygonum cuspidatum* or *Fallopia japonica*) is classified as a hazardous material. When construction occurs in established Japanese Knotweed stands workers sift the soil to remove root fragments and institute treatment plans to ensure that the Knotweed does not re-sprout, as it can damage housing foundations by growing through concrete and asphalt. The contractors must also thoroughly clean their equipment, and dispose of the contaminated soil at biohazard waste sites. While we do not have these requirements in Ontario, Japanese Knotweed is present here.

Invasive plant species can also increase site preparation and weed control costs, and reduce property values. For example, in Vermont the presence of the aquatic invasive plant Eurasian Watermilfoil (*Myriophyllum spicatum*) depressed shoreline residence property value by as much as 16.4% (Zhang and Boyle, 2010).

## Forestry/Agriculture

Invasive plant species which become established in forests will out-compete native species and prevent forest re-generation after logging or natural disturbance. Dog-strangling Vine (*Cynanchum rossicum*) is of particular concern in conifer plantations. This species thrives in the filtered light and open soils of mature plantations, and suppresses seedling establishment of native hardwoods. If its invasion continues, very few juvenile trees will survive to fill the shrinking canopy of over-mature pines. Reforestation sites are also susceptible; the thick mats of vegetation and aggressive competition from Dog-strangling Vine decrease available planting space and increase costs as more mature vegetation needs to be planted in order to ensure the new vegetation can outcompete the invasive plant. As a result, expensive control programs are often required.

## Land Management (Trail Use/Maintenance)

Recreational trail use and the maintenance of trails can facilitate the transport of invasive plant material and seeds, and create open and disturbed sites that are prime locations for the establishment of invasive species. Studies have proven that trails act as corridors which assist in the spread of invasive plant species. Humans, their pets, and vehicles such as ATV's can be vectors of invasion along trails because seeds and plant pieces can be carried on equipment and clothing. In addition, frequent trampling along trails alters soil properties, limits the growth of some native species, and creates conditions that may favour the growth of non-native species (Kuss et al. 1985; Marion et al. 1985; Yorks et al. 1997).

## Roadsides/Utilities

Invasive species can increase the cost of roadside and utility maintenance by requiring additional maintenance and control efforts. The presence of invasive species can also provide a safety hazard. In the case of Phragmites and Miscanthus (invasive grass species), along with interrupting sight lines, the dead stalks which remain standing each autumn also provide combustible material. Fires in these stands burn intensely, and can damage utilities and hydro lines. Phragmites along roadsides is generally assumed to be spread through the transport and burial of rhizome fragments through ditching, ploughing, and other human activities that transport rhizomes on machinery. Studies have shown that vehicles and road-fill operations can transport invasive plant seeds into uninfested areas, and road construction and maintenance operations provide optimal disturbed sites for seed germination and seedling establishment (Schmidt 1989; Lonsdale & Lane 1994; Greenberg et al. 1997; Trombulak & Frissell 2000).

# Steps to Prevent the Unintentional Introduction of Invasive Species from Equipment

Inspection and cleaning of all machinery and equipment should be performed in accordance with the procedures, checklists and diagrams provided in this protocol.

When visiting more than one site, always schedule work in the sites that are the least disturbed and free of known invasive species first, and visit sites with known invasive species infestations last. This will greatly reduce the risk of transferring plants to new locations.

---

## When to Inspect

### Inspection should be done before:

- Moving vehicles out of a local area of operation
- Moving machinery between properties or sites within the same property where invasive species may be present in one area, and not in another
- Using machinery along roadsides, in ditches, and along watercourses
- Vehicles using unformed dirt roads, trails or off road conditions
- Using machinery to transport soil and quarry materials
- Visiting remote areas where access by vehicles is limited

### Inspection should be done after:

- Operating in areas known to have terrestrial invasive plants or are in high risk areas (i.e. recently disturbed areas near known invaded areas)
- Transporting material (i.e. soil) that is known to contain, or has the potential to contain, invasive species
- Operating in an area or transporting material that you are uncertain contain invasive species
- In the event of rain. If mud contains seeds, they can travel indefinitely until it rains or the road surface is wet, allowing for long distance transport. This may result in transporting seeds to areas where those species did not previously exist

---

## How to Inspect

- Inspect the vehicle thoroughly inside and out for where dirt, plant material and seeds may be lodged or adhering to interior and exterior surfaces.
- Remove any guards, covers or plates that are easy to remove.
- Attention should be paid to the underside of the vehicle, radiators, spare tires, foot wells and bumper bars.

If clods of dirt, seed or other plant material are found, removal should take place immediately, using the techniques outlined below.

## When to Clean

Vehicles and heavy equipment that stay on formed and sealed roads have a low risk of spreading invasive species. Cleaning is only required when inspection identifies visible dirt clods and plant material or when moving from one area to another.

Depending on the invasive species present, vehicles may need to be cleaned even when deep snow is present. Phragmites, for example, can still be spread, even in packed snow because the seed heads are usually above the surface of the snow. Other plants, such as Dog-strangling vine, will be contained beneath deep snow.

*\*Regular inspection of vehicles and machinery will identify if any soil or plant material has been collected on or in vehicles and machinery.*

## Where to Clean

Clean the vehicle/equipment in an area where contamination and seed spread is not possible (or limited). The site should be:

- Ideally, mud free, gravel covered or a hard surface. If this option is not available, choose a well maintained (i.e. regularly mowed) grassy area.
- Gently sloping to assist in draining water and material away from the vehicle or equipment. Care should be taken to ensure that localized erosion will not be created, and that water runs back into the area where contamination occurred.
- At least 30m away from any watercourse, water body and natural vegetation.
- Large enough to allow for adequate movement of larger vehicles and equipment.

*\*Safely locate the vehicle and equipment away from any hazards. If mechanized, ensure engine is off and the vehicle or equipment is immobilized.*

## How to Clean Inside

Clean the interior of the vehicle by sweeping, vacuuming or using a compressed air device. Particular attention should be paid to the floor, foot wells, pedals, seats and under the seats.

## How to Clean Outside

Knock off all large clods of dirt. Use a pry bar or other device if necessary.

Identify areas that may require cleaning with compressed air rather than water such as radiators and grills. Clean these areas first prior to using water.

Clean the vehicle with a high pressure hose in combination with a stiff brush and/or pry bar to further assist the removal of dirt clods.

Start cleaning from the top of the vehicle and work down to the bottom.

Emphasis should be placed on the undersides, wheels, wheel arches, guards, chassis, engine bays, radiator, grills and other attachments.

When the cleaning is finished avoid driving through the waste water when removing the vehicle or equipment from the cleaning site.

For equipment such as water trucks that may be exposed to aquatic invasive species, trucks should be disinfected with bleach solution before conducting work in a new area. For further information please refer to the Invading Species Awareness Program's Technical Guidelines listed under Contacts and Resources.



**Hosing down a vehicle in Queensland Australia**

Photo by: TH9 Outdoor Services

# Final Inspection Checklist

**Conduct a final inspection to ensure the following general clean standard has been achieved:**

- No clods of dirt should be visible after wash down.
- Radiators, grills and the interiors of vehicles should be free of accumulations of seed, soil, mud and plant material parts including seeds, roots, flowers, fruit and or stems.

Diagrams have been provided to assist in quickly identifying key areas to inspect and clean on a variety of vehicles associated with the targeted industries. These can be used in combination with vehicle checklists to ensure all areas of the vehicles have been inspected and cleaned.

## Equipment Required

- A pump and high pressure hose OR High pressure water unit
- Minimum water pressure for vehicle cleaning should be at least 90 pounds per square inch. Water can be supplied as high volume/low pressure or low volume/high pressure (NOAA Fisheries Service).
- Air compressor and blower OR Vacuum
- Shovel
- Pry bar
- Stiff brush or broom



**Cleaning station at construction site.**

Photo by: Mark Heaton, OMNR

# Inspection and Cleaning Diagrams and Checklists

## 2WD and 4WD Vehicles

### 4WD VEHICLE WITH KEY SPOTS TO CHECK AND CLEAN

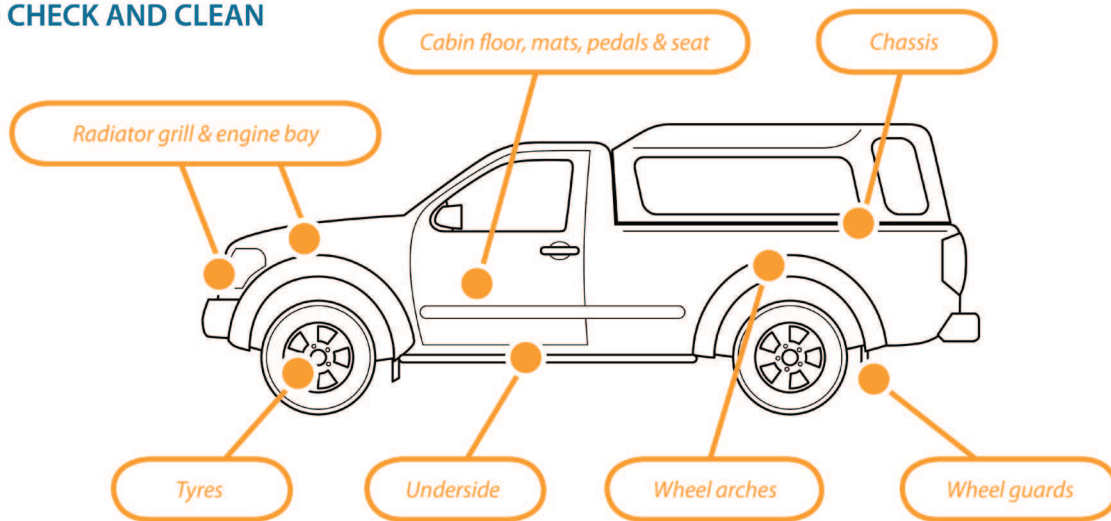

		✓
<b>Cabin</b>	Floor, mats, pedals, seats	
<b>Engine</b>	Radiators, engine bay, grill	
<b>Body</b>	Underside, chassis, crevices, ledges, bumper bars	
<b>Wheels</b>	All wheels (including spare), wheel arches, guards	
<b>Tray</b>	Floor, canopy (if included)	



# Excavator

## EXCAVATOR WITH KEY SPOTS TO CHECK AND CLEAN

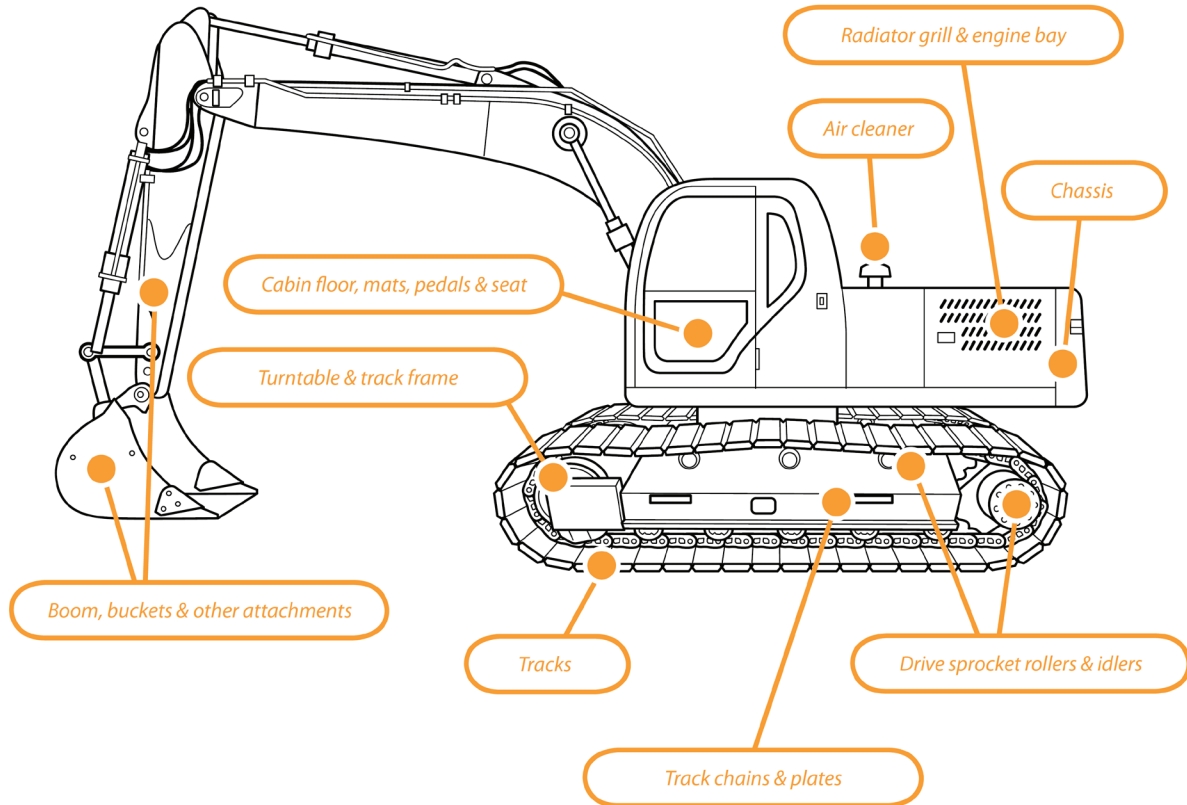

		✓
<b>Cabin</b>	Floor, mats, pedals, seats	
<b>Engine</b>	Radiators, engine bay, grill, air cleaner	
<b>Tracks</b>	Tracks, track frame, drive sprocket rollers, idlers	
<b>Body Plates</b>	Plates of cabin	
<b>Body</b>	Ledges, channels	
<b>Bucket</b>		
<b>Booms</b>		
<b>Turret Pivot</b>		

# Backhoe

## BACKHOE WITH KEY SPOTS TO CHECK AND CLEAN

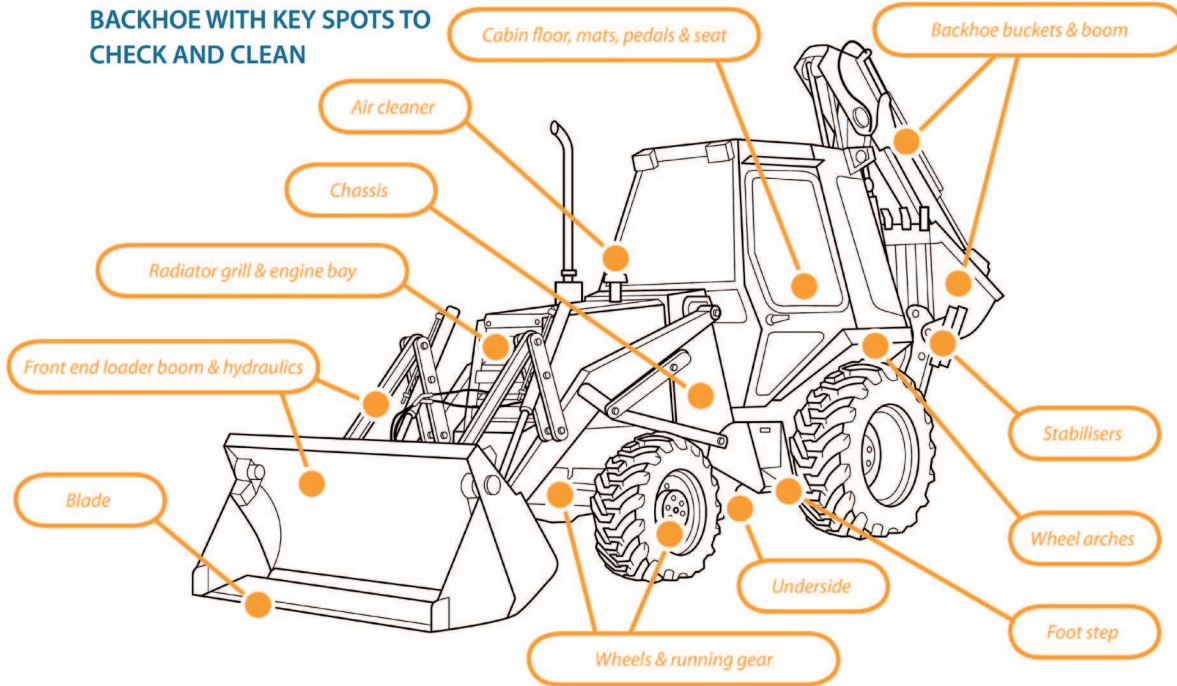

		✓
<b>Cabin</b>	Floor, mats, pedals, seats, foot step	
<b>Engine</b>	Radiators, engine bay, grill, air cleaner	
<b>Wheels</b>	All wheels (including spare), wheel arches, guards	
<b>Front end loader</b>	Blade, hydraulics, booms	
<b>Backhoe</b>	Buckets, boom, hydraulics, stabilizers	

# Bulldozer

## BULLDOZER WITH KEY SPOTS TO CHECK AND CLEAN

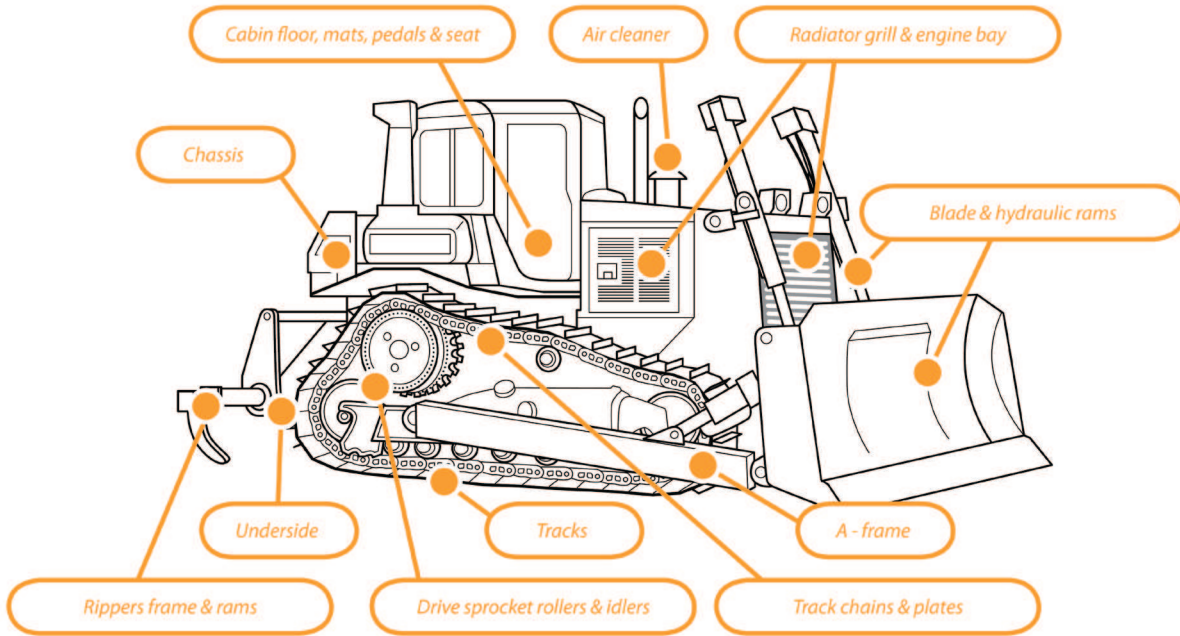

		✓
<b>Cabin</b>	Floor, mats, pedals, seats	
<b>Engine</b>	Radiators, engine bay, grill, air cleaner	
<b>Tracks</b>	Tracks, track frame, drive sprocket rollers, idlers	
<b>Body Plates</b>	Belly plates and rear plates	
<b>Body</b>	Ledges, channels	
<b>Blade</b>	Pivot points, hydraulic rams, a-frame	
<b>Ripper</b>	Ripper frame, ripper points	

# Contacts and Resources

Ontario Invasive Species Strategic Plan 2012. Government of Ontario. Online, accessed May 8, 2012.

[http://www.mnr.gov.on.ca/stdprodconsume/groups/lr/@mnr/@biodiversity/documents/document/stdprod\\_097634.pdf](http://www.mnr.gov.on.ca/stdprodconsume/groups/lr/@mnr/@biodiversity/documents/document/stdprod_097634.pdf)

Invasive Species Management for Infrastructure Managers and the Construction Industry 2008. Wade, M. Booy, O. and White, V. Online, accessed April 27, 2012

[http://www.ciria.org/service/Web\\_Site/AM/ContentManagerNet/ContentDisplay.aspx?Section=Web\\_Site&ContentID=9001](http://www.ciria.org/service/Web_Site/AM/ContentManagerNet/ContentDisplay.aspx?Section=Web_Site&ContentID=9001)

T.I.P.S (Targeted Invasive Plant Solutions) Highway Operations. British Columbia Invasive Species Council. Online, accessed May 8, 2012

[http://www.bcinvvasiveplants.com/iscbc/publications/TIPS/Highways\\_Operations\\_TIPS.pdf](http://www.bcinvvasiveplants.com/iscbc/publications/TIPS/Highways_Operations_TIPS.pdf)

Invading Species Awareness Program Workshop Manual: Aquatic Invasive Species: An Introduction to Identification, Collection and Reporting of Aquatic Invasive Species in Ontario Waters (includes information on decontaminating equipment).

<http://www.invadingspecies.com/download/publications/manuals/WorkshopManual.pdf>

---

## Reporting Invasive Species

To report invasive species, or view maps of existing records, visit the Invading Species Awareness Program website [www.invadingspecies.com/report/](http://www.invadingspecies.com/report/) or [www.eddmaps.org/Ontario](http://www.eddmaps.org/Ontario).

Or call the OFAH/MNR Invading Species Awareness Program Hotline at **1-800-563-7711**

---

## Acknowledgements

We gratefully acknowledge NRM South (Tasmania, Australia) for allowing the use of their artwork and text from their “Keeping it Clean – A Tasmanian Field Hygiene Manual to Prevent the Spread of Freshwater Pests and Pathogens”.

We also sincerely thank the Clean Equipment Protocol Working Group and the Ontario Invasive Plant Council Committees and Board of Directors for their ongoing support and valuable input into this document, and the Canada-Ontario Invasive Species Centre and Ontario Ministry of Natural Resources for the support in creating this protocol.

### Clean Equipment Protocol Working Group:

Diana Shermet, Central Lake Ontario Conservation Authority; Paula Berketo, Ontario Ministry of Transportation; Travis Cameron, Ontario Ministry of Natural Resources; Jennifer Hoare, Ontario Parks; Michael Irvine, Ontario Ministry of Natural Resources; Alison Kirkpatrick, OFAH/MNR Invading Species Awareness Program; Erika Weisz, Ontario Ministry of Natural Resources; Amanda Chad, Ontario Power Generation; Nancy Vidler, Lambton Shores Phragmites Community Group; Nigel Buffone, Du Pont Canada Company; Ewa Bednarczuk, Lower Trent Conservation Authority

We also gratefully acknowledge the input and direction from Francine MacDonald, James Rockwood, Anne-Marie Roussy, Stephen Smith, Caroline Mach, Patricia Lowe, John Bowen, Karen Hartley, and the Southern Ontario Community Forest Managers group.

### More Information:

Ontario Invasive Plant Council: [www.ontarioinvasiveplants.ca](http://www.ontarioinvasiveplants.ca)

# Appendix A: Identification of Invasive Plants found in Ontario

- **Common Buckthorn** (*Rhamnus cathartica*) and **Glossy Buckthorn** (*Frangula alnus*)
- **Dog-strangling Vine** (*Cynanchum rossicum*)
- **Garlic Mustard** (*Alliaria petiolata*)
- **Japanese Knotweed** (*Polygonum cuspidatum*)
- **Phragmites or Common Reed** (*Phragmites australis subsp. australis*)
- **Giant Hogweed** (*Heracleum mantegazzianum*)

## common & glossy buckthorn

(*Rhamnus cathartica* & *R. frangula*)



**Plant type:** Shrub/small tree

**Arrangement:** Common buckthorn are sub-opposite (almost opposite). Glossy buckthorn are alternate.

**Leaf:** The common buckthorn leaf is egg shaped, edge of the leaf is “pebbled” (small rounded teeth). Veins converging toward leaf top. The glossy buckthorn leaf is more slender (tear drop shaped) and smooth margined.

**Bark:** Smooth, young bark with prominent raised patches or lenticels; rough texture and peeling bark when mature.

**Seed/Flowers:** Flowers are green-yellowish, small and inconspicuous. Green berries becoming purplish/black in late summer, berry > 1 cm in diameter.

**Buds/Twigs:** Common buckthorn has thorn-like tip on many twigs. Glossy buckthorn buds have no bud scales and lack thorny tips to twigs.

**Habitat:** Various - forest, thickets, meadows, dry to moist soils.

**Similar native species:** Native dogwoods, which lack the thorny “tip”. Native dogwoods are truly opposite in arrangement of twigs; only alternate leaved (pagoda) dogwood has alternate branching.



## dog-strangling vine

(*Cynanchum rossicum* & *C. nigrum*)



**Plant type:** Herb, twining vine

**Arrangement:** Opposite

**Leaf:** Lance shaped, smooth margin (edge)

**Bark:** n/a

**Seed/Flowers:** Bean shaped seed pod with seeds attached to downy 'umbrellas'. Flowers - pink (*C. rossicum*) or purple (*C. nigrum*) with five petals.

**Buds/Twigs:** n/a

**Habitat:** Dry to moist soils; more dominant in meadows and woodland edges.

**Similar native species:** Swamp milkweed (*Asclepias incarnata* spp.), is an upright plant, typically found in wetland habitats.

## garlic mustard

(*Alliaria petiolata*)



**Plant type:** Herb

**Arrangement:** Alternate

**Leaf:** Saw tooth like edge, elongated heart shape. Garlic/onion smell when crushed. Leaves are kidney shaped with prominent veins.

**Bark:** n/a

**Seed/Flowers:** Cluster of small white flowers with four petals. Small black < 1 mm rounded seed found in elongated 'tube-like' seed pods (similar to a bean pod).

**Buds/Twigs:** n/a

**Habitat:** Various – dry to moist soils, in all habitat types, less often in meadows.

**Similar native species:** n/a

## japanese knotweed

(*Polygonum cuspidatum*)



**Plant type:** Herb, 2 - 4 m in height.

**Arrangement:** Alternate

**Leaf:** Tear drop shaped, sharp pointed, dark green, flattened at base.

**Bark:** n/a

**Seed/Flowers:** Flowering stalk of many small greenish-white flowers.

**Buds/Twigs:** Large plant with a 'bamboo-like' stem. Stem light green maturing to tan colour.

**Habitat:** Moist to wet soils found in wetlands, water-courses and roadside ditches.

**Similar native species:** None.

## common reed

(*Phragmites australis*)



**Plant type:** Grass

**Arrangement:** Alternate

**Leaf:** Broad leaf > 1 cm wide.

**Bark:** n/a

**Seed/Flowers:** Dense cascading 'broom-like' flower head. 'Cottony' in appearance when mature.

**Buds/Twigs:** Stems rough and ridged, ligule a densely hairy band. Mature plants > 3 m tall.

**Habitat:** Moist to wet soils. Found in wetlands, water-courses and road side ditches.

**Similar native species:** Species of mannagrass (*Glyceria* sp) including tall northern, eastern and rattlesnake grass. A native common reed exists but has a smooth stem and the ligule is not hairy. It is also quite rare.

# giant hogweed

(*Heracleum mantegazzianum*)



**Plant type:** Herb. Mature plants can be over 3m tall.

**Arrangement:** Alternate

**Leaf:** Lobed leaf 1-2 m wide, lobes sharp-pointed.

**Bark:** n/a

**Seed/Flowers:** Small, white flowers in a large umbrella-shaped cluster, .75 m wide.

**Buds/Twigs:** Hairy stem with purple spots.

**Habitat:** Fresh to wet soils in forests, swamps, meadows, marshes.

**Similar native species:** Cow parsnip (*Heracleum maximum*) – has smaller flowers, no purple spots on stems. Angelica (*Angelica atropurpurea*) has a rounded-topped flower cluster and leaves divided into many leaflets.

***Do not touch this plant because it is poisonous. If you do, wash your skin immediately in cool soapy water and do not expose the area to sunlight.***

***Seek professional advice before removing.***

## Identification of Invasive Plants found in Ontario Photos by:

Credit Valley Conservation, Greg Bales, Ken Towle, Patrick Hodge,  
Ontario Federation of Anglers and Hunters, Francine Macdonald, Matt Smith





## **Appendix D – Protocol for Wildlife Protection during Construction**

# Protocol for Wildlife Protection during Construction



# City of Ottawa Protocol for Wildlife Protection during Construction

---

## Contents

<b>PREAMBLE</b> .....	<b>3</b>
<b>1 Introduction</b> .....	<b>3</b>
1.1 Application of protocol .....	4
1.2 Other Legislative Requirements .....	4
1.3 Wildlife Expertise .....	4
<b>2 Best Practices</b> .....	<b>5</b>
2.1 Project-specific Wildlife Protocol.....	5
2.2 Sensitive Timing Windows.....	5
2.3 Pre-stressing .....	6
2.4 Site Clearing .....	9
2.5 Construction Site Management .....	10
2.6 Wildlife Encounters.....	11
2.7 Wildlife-proofing.....	12
2.8 Owner Awareness .....	13
<b>3 Conclusion</b> .....	<b>13</b>
<b>4 Additional Resources</b> .....	<b>14</b>

## Tables

Table 1: Sensitive times for wildlife in various habitats, with recommendations for reducing impacts of construction.....	7
---	---

## Appendices

Appendix 1: Example of On-site Reference Handout.....	16
---	----

# City of Ottawa Protocol for Wildlife Protection during Construction

---

## PREAMBLE

The updated City of Ottawa Protocol for Wildlife Protection during Construction has been developed in response to a direction provided by Council on July 17, 2013, as part of the City's Wildlife Strategy. The protocol is a compilation of best practices that serves as a guide and a common frame of reference for the City and the development industry in addressing wildlife protection during construction. The protocol also serves as a guide and frame of reference for City staff involved in planning and carrying out capital projects or other activities that may affect wildlife and wildlife habitat. The protocol itself is not intended to define new requirements for wildlife protection during construction, nor does the protocol provide for proponents of development a means to not adhere to other applicable legislation such as the *Endangered Species Act, 2007* or the *Migratory Birds Convention Act*. The techniques and methods to provide for wildlife protection will continue to be identified by proponents of development through studies that are required as set out in the Official Plan (e.g., Environmental Impact Statements, Tree Conservation Reports) to meet legislative requirements and with consideration to best practices as compiled within this document. Specific requirements for wildlife protection will continue to be defined by staff in consultation with proponents and their consultants, and included as conditions of approval where appropriate through subdivision, condominium and site plans.

## 1 Introduction

This protocol is intended to help reduce the direct impacts of development on wildlife that occur during construction. It also provides some guidance on how to help reduce conflicts between residents and wildlife in newly-constructed neighbourhoods, through better wildlife-proofing and awareness. The protocol complements and supports the City's Environmental Impact Statement (EIS) Guidelines, which address impact assessment and mitigation in a more general way during the development planning and review process, and the Tree Conservation Report (TCR) Guidelines, which address impact assessment and mitigation for trees. The protocol promotes best management practices relating to sensitive timing windows for clearing, pre-stressing, site clearing, construction site management, wildlife encounters, wildlife-proofing, and owner awareness.

## 1.1 Application of protocol

This protocol may be used to guide wildlife protection planning in plans of subdivision, plans of condominium, and site control plans for properties that include or are located adjacent to wildlife habitat, including:

- areas of tall grass;
- shrubs;
- trees or woodlands;
- watercourses;
- wetlands; or,
- complex features such as rock piles, junk heaps, or vacant structures.

Applicants will be advised of the protocol's relevance to their site at pre-consultation.

If a proposed development requires an Environmental Impact Statement or a Tree Conservation Report under the policies of the Official Plan, any recommendations in the EIS/TCR related to mitigating impacts to wildlife from construction activity will be expected to meet or exceed the standard of protection established in this protocol. The recommendations from the EIS/TCR will be used by City staff during the development review process to develop conditions of approval for the project.

This protocol also provides useful information for City staff and members of the public, which can be referred to when planning other projects and activities, such as the development of single lots under a building permit, the construction of new infrastructure, or in non-development related vegetation clearing.

## 1.2 Other Legislative Requirements

This protocol provides guidance on best practices to protect Ottawa's wildlife during construction and related activities. There are several legislative requirements for the protection of various species or groups of wildlife (e.g., provincial *Fish and Wildlife Conservation Act, 1997* and *Endangered Species Act, 2007*; federal *Species at Risk Act, Migratory Birds Convention Act, and Fisheries Act*). It remains the responsibility of the property owners and their agents to ensure that their actions comply with all applicable legal requirements.

## 1.3 Wildlife Expertise

Project proponents will typically rely on professional biologists or environmental consultants to advise them with respect to wildlife. Other potential sources of information and advice on wildlife include wildlife service providers, wildlife rehabilitators and other local experts, as well as relevant agency staff (e.g., Ministry of Natural Resources and Forestry, Canadian Wildlife Service). Links to various sources of additional information that may be useful in wildlife protection planning are provided in Section 4 of this protocol.

Wildlife rehabilitators provide care for orphaned or recuperating wildlife, with the aim of returning them to the wild when they are able to care for themselves. Rehabilitators must receive authorisation from the Ministry of Natural Resources and Forestry (and/or Environment Canada, for migratory birds) on an annual basis. There are very few authorised rehabilitators in the Ottawa area (see links in Section 4). By making pre-arrangements with wildlife rehabilitators, as recommended in this protocol, project proponents can help rehabilitators to

determine whether local capacity exists to handle their potential needs. Rehabilitators and other local experts can also advise proponents on ways to avoid injuring or orphaning wildlife, thus reducing the need for rehabilitation. Similarly, pre-arrangements should be made with local veterinarians to ensure that they are able to treat injured wildlife.

## 2 Best Practices

### 2.1 Project-specific Wildlife Protocol

For some projects where an EIS has identified large areas of wildlife habitat, or particularly sensitive areas of wildlife habitat, a project-specific wildlife protocol may be needed to ensure that the recommendations in the EIS are appropriately implemented during construction. The following information should be clearly conveyed to the on-site staff as part of the project-specific wildlife protocol, via notes on plans, handouts and/or on-site briefings:

- Schedule for pre-construction activities such as inspections for wildlife, installation of protective fencing, pre-stressing, and on-site briefings for contractors;
- Description of wildlife mitigation measures to be used during construction, including;
  - Identification of any natural areas, trees or other features to be retained;
  - Placement and specifications of required protection measures (e.g., fencing, signs);
  - Phasing and direction of site clearing activities;
  - Any recommendations regarding internal access routes for vehicles and other heavy equipment, vehicle parking, materials staging and stockpiling, fuel storage and handling, etc.; and,
- Guidance on how to deal with wildlife encounters, including any species at risk that may be present, and arrangements for dealing with injured or orphaned wildlife. This guidance should be summarized in a handout suitable for quick reference by on-site staff (see example in Appendix 1).

When a project-specific wildlife protocol is needed, it should typically be developed close to or following approval of the project, when the plans have been finalized and more information on scheduling is available. For projects involving early servicing or other site preparation activities in advance of approval, the EIS consultant should provide appropriate advice on wildlife protection measures prior to the commencement of on-site activities. This can be done in conjunction with the Tree Conservation Report requirements, where applicable.

### 2.2 Sensitive Timing Windows

The greatest disruption to wildlife generally occurs when a site is cleared, removing the existing habitat. The timing of site clearing should be carefully considered, because the impacts to wildlife will be greater during sensitive times of the year. During the winter, overwintering and hibernating wildlife may be physically unable to escape from the site, or may freeze or starve to death if forced to leave their dens and food caches. In the spring and summer, most species are more mobile, but mothers will be laying eggs or bearing young. The most profound impacts to wildlife occur when they are displaced from their habitat at such critical times during their life cycle. Table 1 identifies sensitive times of the year for various habitat types and wildlife. This information can be used to determine what time(s) of year may be sensitive at a particular site, based on which types of habitat and wildlife are actually

present. Where possible, site clearing should be planned to occur outside of the applicable sensitive time(s); otherwise, additional mitigation measures should be employed to reduce the impacts.

These timing windows are provided for guidance only, and should not be relied upon in cases where legislated restrictions apply (e.g., under the *Endangered Species Act, 2007*). The federal *Migratory Birds Convention Act* prohibits the unauthorized killing or harassment of migratory birds and the disturbance or taking of their nests and eggs, but does not refer to specific timing windows. The Canadian Wildlife Service (Environment Canada) provides information on how to avoid impacts to migratory birds and their nests during construction, including the timing of bird breeding seasons in Canada (see list of Additional Resources in Section 4.0 below) in order to assist proponents in their project planning; however, these are not legislated dates, and the federal prohibitions apply throughout the year.

All sites should be inspected by a biologist prior to clearing, to identify any potential wildlife issues (e.g., hibernating animals or nursing mothers and their young, etc.) and to inform or adjust mitigation planning as needed. The timing and scope of this inspection will vary depending on the type and extent of habitat to be affected, the availability of existing information about the wildlife on the site (from an EIS or other sources), and the anticipated timing for site clearing. Table 1 includes recommendations for specific habitat searches that should be included in the scope of the EIS, where applicable, or the site inspection. For more information about the timing of site inspections and associated pre-stressing activities that should occur prior to clearing, see Section 2.3, Pre-stressing below.

In cases where site clearing needs to occur during sensitive times of the year (and no regulated restrictions apply) additional mitigation measures may be needed to reduce impacts to wildlife. Potential mitigation measures include:

- More intensive pre-stressing to encourage resident wildlife to leave the site;
- Installation of appropriate nesting boxes around the periphery of the site, to compensate for nesting sites (e.g., cavity trees, squirrel dreys) that will be removed;
- In some cases, where winter food caches will be lost and other sources of food are scarce, supplemental food sources may need to be temporarily provided in safe locations away from the work space;
- Retention of qualified agents to provide on-site monitoring during site clearing, and/or on-call advice and assistance;
- Pre-arrangements made with wildlife rehabilitators and qualified veterinarians to ensure appropriate care of orphaned or injured wildlife.

## 2.3 Pre-stressing

“Pre-stressing” is a term used to describe actions taken to encourage wildlife to move away from a site prior to the onset of construction. Common methods of pre-stressing include having one or more people walk the site while talking loudly or playing loud music, or placing pieces of cloth or other objects that carry a strong human scent into animal dens. To be effective, these measures may need to be combined and repeated several times over the course of two to three weeks. Some common pre-construction activities, such as surveying, or installing protective fencing, can contribute to pre-stressing. In urban areas where wildlife are already accustomed to human presence, pre-stressing using human sounds and scents may be less effective; other repellants may be needed.



**Table 1: Sensitive times for wildlife in various habitats, with recommendations for reducing impacts of construction\***

<b>Habitat Type</b>	<b>Wildlife</b>	<b>Sensitive time(s)</b>	<b>Recommendations</b>
Grasslands and old fields	<p>Migratory birds and raptors Small mammals and other wildlife</p> <p>Note: several Species at Risk birds use grasslands and open habitats; consult Ministry of Natural Resources and Forestry (MNR).</p>	<p>April through mid-August (breeding season for most species)</p> <p>Mid-October through March (for overwintering woodchucks, if present)</p>	<p>Reduce potential wildlife usage by mowing outside of breeding season, then maintain as mowed grass until on-site work begins.</p> <p>Woodchucks, if present, may persist on mowed sites. Avoid impacting burrows during sensitive times for this species, where possible.</p>
Shrubs or trees (growing as individuals or in small clumps or hedgerows)	<p>Migratory birds and raptors Small mammals and other wildlife</p>	<p>The following only apply if wildlife are actually using the habitat:</p> <p>March through mid-August (breeding season for most species)</p> <p>Mid-October through March (for cavity trees or other den sites)</p>	<p>Retain a biologist to inspect habitat. If no active nests or dens are present, clearing should be done within a few days of inspection (during sensitive times of year, clearing should occur the same day if possible).</p>
Thickets or woodlands	<p>Migratory birds and raptors Mammals and other wildlife</p> <p>Note: several Species at Risk use thicket, edge and woodland habitats; consult MNR.</p>	<p>March through mid-August (breeding season for most species)</p> <p>Mid-October through March (for overwintering wildlife)</p>	<p>Do not clear during sensitive times of the year, unless mitigation measures are used to reduce risks to wildlife.</p> <p>The Canadian Wildlife Service does not support relying on inspections for migratory bird nests in such habitats, due to the difficulty of locating all nests and the risk to the birds.</p>
Complex features (e.g., piles of	Mammals and other wildlife (e.g., snakes)	March through July (breeding season for most)	Retain a biologist to inspect habitat prior to removal. In cases where

\*NOTE: The information in this Table can be used to determine what time(s) of year may be sensitive at a particular site, based on which types of habitat and wildlife are actually present. Where possible, site clearing should be planned to occur outside of the applicable sensitive time(s); otherwise, additional mitigation measures should be employed to reduce the impacts. The recommendations provided do not address Species at Risk requirements under the *Endangered Species Act, 2007*. For situations involving Species at Risk, regulated timing restrictions, mitigation measures or compensation requirements may apply (consult the Ministry of Natural Resources and Forestry for more information).

**Table 1: Sensitive times for wildlife in various habitats, with recommendations for reducing impacts of construction\***

<b>Habitat Type</b>	<b>Wildlife</b>	<b>Sensitive time(s) species)</b>	<b>Recommendations</b>
rock or wood, stone walls, derelict vehicles, junk heaps, etc.)		<p>October through March (for overwintering wildlife, including snakes)</p>	<p>presence of wildlife is confirmed or uncertain, disassemble slowly, outside of relevant sensitive time(s), to reduce potential impacts and allow wildlife time to relocate.</p>
Vacant buildings or other structures	<p>Some birds Small mammals and other wildlife (e.g., snakes)</p> <p>Note: some Species at Risk, including barn swallows and little brown bats, use buildings and other structures; consult MNRF.</p>	<p>March through mid-August (breeding season for most species)</p> <p>Mid-October through March (for overwintering wildlife)</p>	<p>Retain a biologist to inspect habitat prior to removal. In cases where presence of wildlife is confirmed or uncertain, demolition may need to be done in controlled stages, outside of relevant sensitive time(s), to reduce potential impacts and allow wildlife time to relocate.</p>
Wetlands and waterbodies	<p>Migratory birds, including waterfowl Mammals Aquatic reptiles and amphibians Fish</p> <p>Note: many Species at Risk use wetlands and other aquatic habitats; consult MNRF.</p>	<p>March through August (breeding season for most species); note that this includes regulated in-water timing restriction for warmwater fishes (March 15 to June 30)</p> <p>August through October (emergence of hatchling turtles, if turtle nests are present)</p> <p>Mid-October through March (for overwintering wildlife, including turtles)</p>	<p>Do not clear during sensitive times of the year, except in cases where exclusion fencing or other mitigation measures can be used to reduce risks to wildlife.</p> <p>Exclusion fencing can be useful when working in or around these habitats, to prevent wildlife (especially turtles) from entering work areas.</p> <p>Fish and other highly aquatic wildlife such as turtles and frogs may need to be relocated prior to commencing work (permits required from MNRF for relocation).</p>

\*NOTE: The information in this Table can be used to determine what time(s) of year may be sensitive at a particular site, based on which types of habitat and wildlife are actually present. Where possible, site clearing should be planned to occur outside of the applicable sensitive time(s); otherwise, additional mitigation measures should be employed to reduce the impacts. The recommendations provided do not address Species at Risk requirements under the *Endangered Species Act, 2007*. For situations involving Species at Risk, regulated timing restrictions, mitigation measures or compensation requirements may apply (consult the Ministry of Natural Resources and Forestry for more information).

Timing and frequency of pre-stressing activities will vary depending on the site context, the amount of information known about wildlife at the site, and the proposed schedule for site clearing. Suggested site inspection and pre-stressing schedules are as follows:

- For sites with good wildlife information and/or little habitat to be affected, that will be cleared outside of any applicable sensitive timing windows (low risk of impacts): one site inspection combined with pre-stressing within a few days prior to clearing.
- For sites with poor wildlife information and/or larger areas of habitat being affected, that will be cleared outside of any known sensitive timing windows (moderate risk of impacts): first site inspection 2-3 weeks in advance, with pre-stressing and follow up inspections as needed based on results; final inspection/pre-stressing on the day before clearing for each phase.
- For sites that will be cleared during sensitive times of the year (high risk of impacts): first site inspection 3+ weeks in advance with multiple pre-stressing and follow up inspections; final inspection/pre-stressing on the day before clearing for each phase.

Note: for sites located within or adjacent to existing developed areas, nearby residents should be informed about the onset of pre-stressing activities and the potential for increased encounters with wildlife dispersing from the site. Sources of information on avoiding conflicts with wildlife should be provided (see Section 4). The City's Noise By-law needs to be respected.

## 2.4 Site Clearing

Vegetation removal (including mowing of tall grass) and other site clearing activities should proceed in phases, generally moving from the most disturbed part of the site (closest to existing development) towards the least disturbed part of the site. Even on small sites that can be cleared in a single day, it is important to follow this pattern in order to "herd" wildlife out of the site into adjacent undisturbed habitat, or towards the nearest habitat. Some examples of possible scenarios are provided below. Site clearing should be timed to avoid disturbance of habitat areas during sensitive times of the year (see Section 2.2) where possible.

### **Scenario 1: The work space directly abuts a natural area or open space that will be protected and retained.**

Site clearing activities should begin at the far side of the property from the retained natural area and proceed towards it. The goal is to ensure that any wildlife within the work space can retreat into the retained natural area without having to cross cleared lands.

### **Scenario 2: There is an existing natural connection (stream corridor, hedgerow or other natural linkage) between the work site and a nearby natural area.**

Site clearing activities should be phased to funnel wildlife towards the existing connection. Areas of habitat within the work space should not become isolated from the connection until the final stages of this process.

### **Scenario 3: The site includes one or more isolated areas of habitat to be cleared, with no existing connection to other natural areas nearby.**

One or more open “escape routes” between the habitat and the edge of the site should be maintained until the final phases of vegetation clearing are completed. These escape routes should be defined on the site with fencing to ensure they stay open, and to help channel wildlife movement. Clearing should begin at the far side of the habitat and proceed towards the designated escape route.

In all cases, each area to be cleared should be inspected (and, if necessary, pre-stressed) by the project biologist one more time the day before clearing, to determine whether any trees or other habitat features are still being used by wildlife. Any occupied trees/features should be flagged for temporary retention for at least one additional day, to allow wildlife a last chance to move out. In cases where occupancy is uncertain, the same precaution should apply. If they do not leave on their own, then it may be necessary to have a professional wildlife service provider relocate them, in accordance with applicable laws (e.g., *Fish and Wildlife Conservation Act, 1997* for most commonly encountered wildlife species). Relocation is not an option for some species; for example, if a migratory bird is nesting on site, a protected buffer zone may need to be established and maintained until the birds are finished nesting (the width of such buffer zones varies depending on the species, and should be determined by the project biologist in consultation with Environment Canada). This may affect the phasing or overall schedule for site clearing and subsequent on-site activities.

Any fencing between the work space and the natural habitat to which wildlife are being directed during site clearing must allow for wildlife passage; otherwise, wildlife may be unable to escape from the site. Acceptable fencing options are those which provide low gaps at the bottom of the fence to permit passage by small to medium species, and which are no more than 1.2 m high for larger species such as deer to leap over. Plastic snow fencing can be used, if suitable gaps are provided at intervals along the bottom edge (these can be cut out, or natural gaps caused by uneven terrain at the base of the fence). Once the work space has been cleared, these gaps should be closed or a more secure perimeter fence can be installed to reduce the risk of wildlife returning to the site.

## **2.5 Construction Site Management**

Construction sites are normally managed to promote safety, efficiency and legal compliance. Site management is a key factor in reducing the overall environmental impact of the project, by controlling the risks of environmental contamination, soil compaction, and damage to trees and other natural features intended for retention. It also helps to reduce the risks to wildlife, by controlling the activities on-site that could directly or indirectly harm them.

All personnel should be briefed about wildlife protection measures at the outset of the project, in order to ensure that these measures are clearly understood and appropriately implemented. The briefing needs to provide an overview of the mitigation measures that are being used at the site, as well as instructions on what to do if and when wildlife are encountered during the work. It should also include information on any species at risk that may be present, and what to do if one is seen. A laminated handout summarising key information on wildlife protection should be kept on-site at all times for reference by staff (see example of a handout in Appendix 1). The handout should be tailored to suit the needs of each specific project, but should address the following subjects:

- General provisions – e.g., do not harm, feed or unnecessarily harass wildlife; drive slowly and avoid hitting wildlife where possible; keep site tidy and secure
- Species at risk – basic identification tips and recommendations (needs to be modified to address species most likely to be encountered at the site)
- Contact information for:
  - Project biologist / wildlife service provider
  - Ministry of Natural Resources and Forestry, Kemptville (for species at risk)
  - Wildlife rehabilitators and veterinarians (for orphaned or injured wildlife)

The management of the site needs to specifically address how to avoid attracting wildlife to the work space. Although on-site activities will generally discourage wildlife from entering the work space during the day, they may be drawn to the site at night (or on weekends) if it appears to provide sources of food, water or shelter. The following common attractants should be controlled or eliminated:

- Food wastes and other garbage – effective mitigation measures include waste control (prevent littering); keeping all trash secured in wildlife-proof containers, and prompt removal from the site (especially in warm weather).
- Water – effective mitigation measures include ensuring proper site drainage to limit standing pools of water; fencing off temporary storm ponds and other waterbodies within the work space (and not permitting wildlife access to any potentially contaminated waterbodies); and, use appropriate sediment and erosion control measures to protect the quality of surface water adjacent to or downstream of the work space.
- Shelter – effective mitigation measures include covering or containing piles of soil, fill, brush, rocks and other loose materials; capping ends of pipes where necessary to keep wildlife out; ensuring that trailers, bins, boxes, and vacant buildings are secured at the end of each work day to prevent access by wildlife.

While all personnel need to be aware of the wildlife protection measures, one or more people should be specifically tasked with ensuring that those measures are properly implemented, by performing the following duties:

- Checking the work site (including previously cleared areas) for wildlife, prior to beginning work each day;
- Regularly inspecting protective fencing or other installed measures to ensure their integrity and continued function; and,
- Monitoring construction activities to ensure compliance with the project-specific protocol (where applicable) or any other requirements.

For simple, low-risk projects, construction staff may be able to undertake this work (with help from contracted professionals if any issues arise). Large-scale or complex projects may benefit from the presence of a part or full time specialist such as an environmental officer, biologist or wildlife service provider, particularly during site clearing. Professional expertise is strongly recommended in cases where site clearing is being carried out during sensitive times of the year.

## 2.6 Wildlife Encounters

Ideally, the mitigation measures described above would allow all local wildlife to vacate the site before it was cleared, and no wildlife would return until the project was completed. In reality, however, it is very likely that wildlife will be encountered on-site at some point during the construction process. Wildlife may return to the site after dark, seeking the habitat that used to

be there. They may also be attracted to the site if it appears to provide food, water or shelter, as previously described in Section 2.5. Proper site management will reduce the risk of wildlife trying to move back onto the site, while daily inspections before work begins will reduce the risk of harm to any wildlife that has wandered in overnight.

Any wildlife encountered during site clearing or subsequent construction activities should be allowed to exit the site on their own, via safe routes. Construction staff should not attempt to capture or handle most kinds of wildlife, unless an animal is in imminent peril or is injured and cannot wait for rescue by qualified personnel. Improper handling can result in injuries to both workers and wildlife, and may in some cases contravene provincial or federal legislation. Removal and relocation of mammals, in particular, should only be done by qualified wildlife service providers working in accordance with applicable laws (i.e., *Fish and Wildlife Conservation Act, 1997*).

If young birds or mammals are discovered on a site, contact the project biologist, a wildlife rehabilitator, or other wildlife expert for advice. In most cases, they should be left alone. The mother is very likely nearby and will return if given the chance. For primarily nocturnal species like raccoons and skunks, she may wait until evening to move her family to a safe location.

Useful equipment for wildlife encounters:

- Work gloves, to reduce the risk of injury from bites or scratches
- Push broom for gently redirecting small mammals, reptiles or amphibians
- Clean (uncontaminated) towels or blankets and assorted containers such as plastic sweaterboxes, cat carriers, and a large bin or garbage can for capturing and transporting injured or orphaned wildlife (note: small cardboard boxes or unwaxed paper bags are best for small birds)

Scratches and bites from animals, whether domestic or wild, can result in serious infections and/or transmit diseases. Immediate medical treatment should be sought for any person injured by an animal.

## 2.7 Wildlife-proofing

Wildlife can cause significant property damage and even health and safety issues when they seek shelter in, on or under buildings. Wildlife-proofing measures have been developed to address these problems, but many of these measures are typically installed by building owners in response to an issue, rather than being installed proactively during the construction of the building. The Ontario Building Code (OBC) does not address the subject of wildlife-proofing in great detail. It does require that sources of natural ventilation (other than windows) be constructed to provide protection from insects and weather, and that outdoor air intakes and exhaust outlets should be screened to prevent entry of animals and insects. However, these requirements alone may not protect a building from wildlife determined to find a way in. The most common access points are through vents, chimneys, roofs and eaves; wildlife will also frequently seek shelter underneath porches, stairs and raised decks.

Builders and contractors are encouraged to go beyond the requirements of the OBC and provide their clients with additional built-in protection against wildlife. This could include upgrading materials to use more wildlife-resistant metal components instead of plastic. Heavy screening or other exclusion measures could be installed to keep wildlife out of crawl spaces under porches or exterior stairs, including below grade to deter digging animals. Quality

assurance programs should include checking for any loose external fittings or gaps that could allow access by wildlife.

Buildings which feature large windows or other expanses of glass may need a different type of wildlife-proofing. These buildings can pose a risk to birds, which may not recognise the glass as a barrier. Many birds are injured and killed in collisions with glass each year, especially during spring and fall migration. Several major cities across North America, including Toronto and Vancouver, have introduced bird-friendly design guidelines to address this issue. FLAP Canada also provides advice on how to reduce risks to birds on its website (see Section 4, Additional Resources, below). Architects are encouraged to consider the potential risks to birds when designing buildings with glass exteriors or large banks of windows, and to take steps to reduce those risks.

## 2.8 Owner Awareness

Once construction has been completed, the potential conflicts between people and wildlife living in the new development can generally be best handled through education. “Owner Awareness Packages” are commonly required as a mitigation measure for new developments in or adjacent to natural areas. These packages are intended to inform residents about the environmental significance and sensitivities of the natural areas, and also to provide guidance on how to avoid having (or causing) problems, including conflicts with wildlife. There are many available sources of information to draw upon when assembling such packages (see Section 4). The finished product may consist of a simple brochure or one-pager, or may be a more comprehensive handbook. It should include:

- Basic information about common wildlife that may be expected to occur in the area;
- Information about any species at risk that residents should be aware of, and the legal protections associated with these species;
- Information on potential implications of allowing pets to roam unattended (including possible impacts to pets and/or wildlife, as well as legal restrictions under municipal and provincial regulations);
- Recommendations for maintenance of any wildlife-proofing measures included in the building;
- Suggestions on other ways to avoid or reduce human-wildlife conflicts; and,
- Sources of additional information.

## 3 Conclusion

By following this protocol and planning ahead for wildlife protection, project proponents should be able to reduce construction-related impacts on Ottawa’s wildlife, remain compliant with federal and provincial legislation, and help residents to avoid problems with wildlife in the longer term.

## 4 Additional Resources

City of Ottawa – information on Ottawa’s wildlife and conflict avoidance at <http://ottawa.ca/en/residents/water-and-environment/animals-ottawas-wildlife>

Environment Canada (Canadian Wildlife Service) – information on avoiding incidental take of migratory birds at <http://www.ec.gc.ca/paom-itmb/default.asp?lang=En&n=C51C415F-1>

Environment Canada (Canadian Wildlife Service) – general nesting periods of migratory birds in Canada at <http://www.ec.gc.ca/paom-itmb/default.asp?lang=En&n=4F39A78F-1>

FLAP Canada – information on how to reduce building-related risks to birds, including links to various cities’ bird-friendly design guidelines, at <http://www.flap.org/index.php>

Government of Canada – Species at Risk Public Registry, including information on all federally listed species at risk, at <http://www.registrelep-sararegistry.gc.ca/default.asp?lang=en&n=24F7211B-1>

Ministry of Natural Resources and Forestry – information on Species at Risk in Ontario at <http://www.ontario.ca/environment-and-energy/species-risk>

Ministry of Natural Resources and Forestry – contact information for authorized wildlife rehabilitators at <http://www.ontario.ca/environment-and-energy/find-wildlife-rehabilitator>

Ministry of Natural Resources and Forestry – illustrated instructions on safe handling of turtles, snakes, amphibians and birds, as well as directions on appropriate relocation and reporting of species at risk encounters, in the “Ontario Species at Risk Handling Manual: For Endangered Species Act Authorization Holders” at [http://files.ontario.ca/environment-and-energy/species-at-risk/mnr\\_sar\\_tx\\_sar\\_hnd\\_mnl\\_en.pdf](http://files.ontario.ca/environment-and-energy/species-at-risk/mnr_sar_tx_sar_hnd_mnl_en.pdf)

Ministry of Natural Resources and Forestry – Species at Risk Branch Best Practices Technical Note on Reptile and Amphibian Exclusion Fencing, at [http://files.ontario.ca/environment-and-energy/species-at-risk/mnr\\_sar\\_tx\\_rptl\\_amp\\_fnc\\_en.pdf](http://files.ontario.ca/environment-and-energy/species-at-risk/mnr_sar_tx_rptl_amp_fnc_en.pdf)

Ottawa-Carleton Wildlife Centre – information on commonly encountered species and conflict avoidance at <http://wildlifeinfo.ca/index.html>

Ottawa Humane Society – emergency response for injured wildlife, guidance on common wildlife issues, and information on wildlife service providers at <http://www.ottawahumane.ca/protection/wildlifeissues.cfm>

Ottawa Stewardship Council – Species at Risk Handbook for Ottawa at <http://www.ottawastewardship.org>

Rideau Valley Wildlife Sanctuary – wildlife rehabilitation centre; information on what to do for apparently orphaned or injured wildlife at <http://www.rideauwildlife.org/index.html>

Wild Bird Care Centre – wild bird rehabilitation centre; information on avoiding conflicts with birds and what to do for apparently orphaned or injured birds at <http://wildbirdcarecentre.org/index.php>



## Appendix 1: Example of On-site Reference Handout

### General Provisions:

- Watch out for wildlife while driving, and avoid hitting them, provided that it is safe to do so.
- Ensure sediment and erosion control measures (i.e., silt fencing) and other protective measures are in place prior to beginning work. Inspect them regularly, and particularly after storm events, to ensure their continued effectiveness.
- Prior to beginning work each day, check for wildlife by conducting a thorough visual inspection of the work space and immediate surroundings.
- Restrict all activities, vehicles and materials to the designated work space. Do not disturb areas identified for retention.
- Secure stockpiled materials, vehicles and structures against wildlife entry.
- Litter and other waste materials must be appropriately contained and promptly disposed of.
- Do not feed any wildlife or leave food out where it could attract them.

**For health and safety reasons, and for protection of animals, removal and relocation of mammals must only be done by qualified and properly equipped personnel. Call the wildlife service provider [NAME] at (613) XXX-XXXX for assistance.**

**For injured wildlife, call the Ottawa Humane Society Emergency Services at (613) 725-1532. For injured birds, call the Wild Bird Care Centre at (613) 828-2849.**

**Scratches and bites from animals, whether domestic or wild, can result in serious infections and/or transmit diseases. Seek medical treatment immediately for any person injured by an animal.**

### Wildlife Encounters:

- **Do not harm any wildlife.** Many species are protected under provincial and/or federal legislation. Legal protection of egg-laying species applies to their eggs as well. Penalties for contravening these Acts can be severe.
- **Stand back** and allow the animal to leave the site. Wildlife may be encouraged to move away from the work area by shouting, waving of arms, clapping of hands or gentle redirection using a push broom. Contact project biologist / wildlife service provider for assistance if needed (e.g., if young animals are found). Do not unnecessarily harass any wildlife.
- **Turtles** may need to be helped to safety. Our most common species, Painted and Snapping Turtles, are protected under the Fish and Wildlife Conservation Act, 1997. If one of these turtles is found in the work area, it can be gently removed to a safe location nearby. Wear gloves, or use a broom to steer the turtle into a bucket or other container. Handle with care to avoid injury to the turtle or yourself, particularly when dealing with Snapping Turtles, which may bite or scratch. Turtles may also wet themselves when handled.
- Most of Ottawa's **snakes** are protected under the Fish and Wildlife Conservation Act, 1997. None of them are venomous, but bites may cause infections. Some produce a foul-smelling musk when handled, instead of biting. Snakes will usually try to escape or hide when disturbed, and only defend themselves when trapped. If a snake is found in the work area, it should be gently herded out to a safe location.
- **Stop work immediately** if any species protected under the Endangered Species Act, 2007 are seen in or near the work site (see attached sheet for tips on identifying some commonly encountered species). Take a photograph if possible, to confirm the sighting, and contact the project biologist at (613) XXX-XXXX and the Ontario Ministry of Natural Resources and Forestry – Kemptville District, at (613) 258-8204 or [sar.kemptville@ontario.ca](mailto:sar.kemptville@ontario.ca). Additional measures to avoid impacts may be required by the Ministry before work can restart.

## Commonly Encountered Species Protected under the Endangered Species Act, 2007

For more information on Ottawa's species at risk, refer to <http://www.ottawastewardship.org>

### Barn Swallow

Dark metallic blue above, buff to orange below. Long, deeply forked tail and pointed wings. Very quick and agile in flight. Cup-shaped nests built of mud and plant fibres on buildings and other structures, including bridge supports and culverts.



Male



Female



Nest

Bank Swallows are similar in shape to Barn Swallows, but do not have such long, deeply forked tails. They are dull brown above and white underneath, with a brownish band across the chest. They nest in burrows dug in exposed soils on steep slopes (e.g., sand pits, fill piles).

### Blanding's Turtle

Bright yellow chin and throat. Highly domed, speckled shell up to 28 cm (11 in) in length.

Eggs small, oval and white. Usually less than 12 eggs per nest.



^ Photo courtesy of R. van de Lande

### Bobolink

Males black with white back and cream hood during spring and summer breeding season. Females and non-breeding males streaky brown. Nests on the ground in open grasslands and hayfields.



All photos by A. MacPherson unless otherwise specified.

### Butternut

Also known as White Walnut. Each leaf has several pairs of leaflets on either side of the main stalk, and one leaflet at the tip. Leaves and twigs grow in an alternating pattern along the branches. The nuts resemble limes or lemons in shape, and have greenish-yellow fuzzy rinds covering a hard, brown, ridged shell.



Butternut tree (centre)



Butternut leaves and fruit



Opened shell of butternut (without rind)

The closely related Black Walnut, which is not a species at risk, has round nuts like tennis balls. Its leaves are very similar to Butternut's leaves, but the terminal leaflet at the tip of each leaf is often much smaller than the other leaflets, or missing entirely. Ash trees may also appear similar to Butternut at first, with very similar leaves, but ash leaves and twigs grow in opposite pairs rather than alternating.

### Eastern Meadowlark

Streaky grayish-brown bird with bright yellow front marked by black "V." Short tail has white edges on each side. Nests on the ground in open grassy areas; often seen perching on fence posts or shrubs.

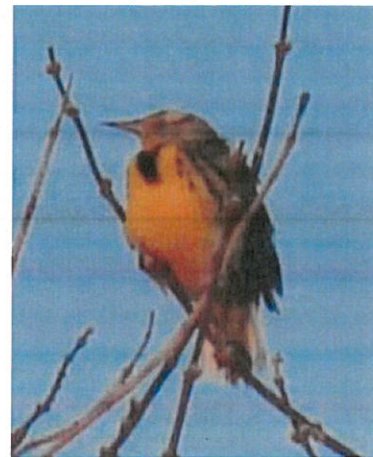

All photos by A. MacPherson unless otherwise specified.