

LEGEND

- [Symbol] BARRIER CURB
- [Symbol] CURB DEPRESSION
- [Symbol] HEAVY DUTY ASPHALT
- [Symbol] CONCRETE RAMP AND/OR WALKWAY
- [Symbol] SWALE CENTERLINE
- [Symbol] TERRACING @ 3:1 SLOPE UNLESS SPECIFIED
- [Symbol] LSCB LANDSCAPE CATCH BASIN
- [Symbol] CBMH CATCH BASIN MANHOLE
- [Symbol] CB CATCH BASIN OR DITCH INLET
- [Symbol] MH1A SANITARY MANHOLE
- [Symbol] 73.21 TYPICAL GRADE
- [Symbol] ×73.21 B/W BOTTOM OF WALL GRADE
- [Symbol] ×73.21(S) SWALE GRADE
- [Symbol] T/G 73.21 TOP OF GRATE GRADE
- [Symbol] ×EX.73.21 EXISTING GRADE (NOT SHOWN ON SURVEY)
- [Symbol] → OVERLAND FLOW ROUTE
- [Symbol] 100yr PONDING
- [Symbol] 5yr PONDING
- [Symbol] × 76.16 GRADE MARKER
- [Symbol] SILT FENCE

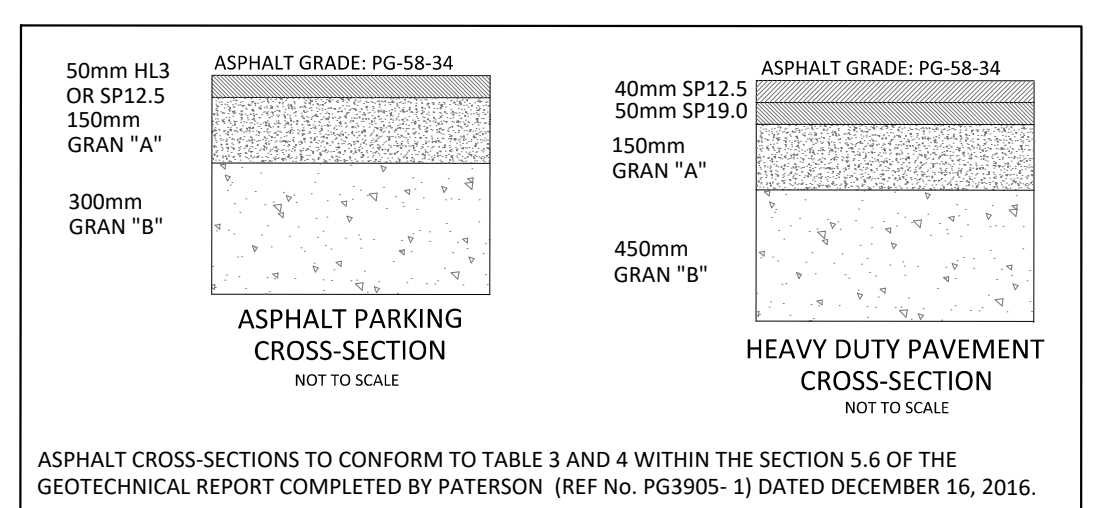

- GENERAL NOTES**
- THE ORIGINAL TOPOGRAPHY, GROUND ELEVATION AND SURVEY DATA SHOWN ARE SUPPLIED FOR INFORMATION PURPOSES ONLY, AND IMPLY NO GUARANTEE OF ACCURACY. IT SHALL BE THE RESPONSIBILITY OF THE CONTRACTOR TO VERIFY ALL INFORMATION SHOWN.
 - THIS PLAN IS NOT A CADASTRAL SURVEY SHOWING LEGAL PROPERTY BOUNDARIES AND EASEMENTS. THE PROPERTY BOUNDARIES SHOWN HEREON HAVE BEEN DERIVED FROM INFORMATION SUPPLIED BY (OR SHOWN ON) MCINTOSH PERRY SURVEYING INC. DATED NOVEMBER 02, 2016 AND CANNOT BE RELIED UPON TO BE ACCURATE OR COMPLETE. THE PRECISE LOCATION OF THE CURRENT PROPERTY BOUNDARIES AND EASEMENTS CAN ONLY BE DETERMINED BY AN UP-TO-DATE LAND TITLES SEARCH AND A SUBSEQUENT CADASTRAL SURVEY PERFORMED AND CERTIFIED BY AN ONTARIO LAND SURVEYOR.
 - THE CONTRACTOR IS TO OBTAIN AND PAY FOR ALL NECESSARY PERMITS AND APPROVALS FROM THE CITY OR TOWNSHIP BEFORE COMMENCING CONSTRUCTION.
 - THE CONTRACTOR IS RESPONSIBLE FOR ALL LAYOUT.
 - THE CONTRACTOR IS TO DETERMINE THE EXACT LOCATION, SIZE, MATERIAL AND ELEVATION OF ALL EXISTING UTILITIES PRIOR TO COMMENCING CONSTRUCTION. PROTECT AND ASSUME ALL RESPONSIBILITY FOR EXISTING UTILITIES WHETHER OR NOT SHOWN ON THESE DRAWINGS. IF THERE IS ANY DISCREPANCY THE CONTRACTOR IS TO NOTIFY THE ENGINEER PROMPTLY.
 - ALL 'GREEN AREAS' TO BE TREATED WITH 150mm TOPSOIL AND SOD AS SOON AS FEASIBLE.
 - RESTORE ALL TRENCHES AND SURFACES OF PUBLIC ROAD ALLOWANCES TO CONDITION EQUAL OR BETTER THAN ORIGINAL CONDITION AND TO THE SATISFACTION OF THE CITY OR TOWNSHIP AUTHORITIES.
 - EXCAVATE AND DISPOSE OF ALL EXCESS EXCAVATED MATERIAL, SUCH AS ASPHALT, CURBING AND DEBRIS, OFF SITE AS DIRECTED BY THE ENGINEER AND THE CITY OR TOWNSHIP.
 - TOPSOIL TO BE STRIPPED AND STOCKPILED FOR REHABILITATION. CLEAN FILL TO BE PLACED IN FILL AREAS AND COMPACTED TO 95% STANDARD PROCTOR DENSITY.
 - ALL DISTURBED AREAS TO BE RESTORED TO ORIGINAL CONDITION OR BETTER UNLESS OTHERWISE SPECIFIED.
 - THE CONTRACTOR SHALL BE RESPONSIBLE FOR ALL TRAFFIC CONTROL AND SAFETY MEASURES DURING THE CONSTRUCTION PERIOD, INCLUDING THE SUPPLY, INSTALLATION, AND REMOVAL OF ALL NECESSARY SIGNAGE, DELINEATORS, MARKERS AND BARRIERS.
 - DO NOT ALTER GRADING OF THE SITE WITHOUT PRIOR APPROVAL OF THE CITY OR TOWNSHIP.
 - ALL ROADWAY, PARKING LOT, AND GRADING WORKS TO BE UNDERTAKEN IN ACCORDANCE WITH CITY OR TOWNSHIP STANDARDS AND SPECIFICATIONS. THE CONTRACTOR IS TO PROVIDE POSITIVE DRAINAGE AWAY FROM THE BUILDING.
 - CONTACT THE CITY OR TOWNSHIP FOR INSPECTION OF ROUGH GRADING OF PARKING LOTS, ROADWAYS AND LANDSCAPED AREAS PRIOR TO PLACEMENT OF ASPHALT AND TOPSOIL. ALL DEFICIENCIES NOTED SHALL BE RECTIFIED TO THE TOWNSHIP'S SATISFACTION PRIOR TO PLACEMENT OF ANY ASPHALT, TOPSOIL, SEED & MULCH AND/OR SOD.
 - ALL DIMENSIONS AND INVERTS MUST BE VERIFIED PRIOR TO CONSTRUCTION, IF THERE IS ANY DISCREPANCY THE CONTRACTOR IS TO NOTIFY THE ENGINEER PROMPTLY.
 - HYDRO, GAS, TELEPHONE AND TELEVISION SERVICE LOCATIONS SUBJECT TO THE APPROVAL AGENCY:
 - ELECTRICAL SERVICE - HYDRO OTTAWA,
 - GAS SERVICE - ENBRIDGE,
 - TELEPHONE SERVICE - BELL CANADA,
 - TELEVISION SERVICE - ROGERS.
 - INSTALLATION TO BE IN ACCORDANCE WITH CURRENT CODES AND STANDARDS OF APPROVAL AGENCIES BELL, HYDRO AND THE CITY OR TOWNSHIP.
 - ALL PROPOSED CURB SHALL BE CONCRETE BARRIER CURB UNLESS SPECIFIED.
 - ALL EXISTING REDUNDANT PRIVATE APPROACHES FRONTING THIS DEVELOPMENT MUST BE REMOVED TO THE SATISFACTION OF THE CITY OR TOWNSHIP.
 - THIS PLAN MUST BE READ IN CONJUNCTION WITH GEOTECHNICAL REPORT BY PATERSON GROUP INC. REPORT # PG3905-1 DATED DECEMBER 16, 2016, AND SITE SERVICING REPORT BY MCINTOSH PERRY REPORT # CP-15-0429 DATED, JANUARY 20, 2017.

- SEWER NOTES**
- CONSTRUCT ALL SEWER AND APPURTENANCES TO ONTARIO PROVINCIAL STANDARD SPECIFICATIONS AND DRAWINGS, AS WELL AS THE CITY OR TOWNSHIP STANDARDS AS INDICATED.
 - SEWER TRENCHING AND BEDDING SHALL CONFORM TO OPSD 802.010 AND 802.013 UNLESS NOTED OTHERWISE.
 - BEDDING SHALL BE A MINIMUM 150mm OF GRANULAR "A", COMPACTED TO MINIMUM 95% STANDARD PROCTOR DRY DENSITY. CLEAR STONE BEDDING SHALL NOT BE PERMITTED.
 - SUB-BEDDING, IF REQUIRED SHALL BE AS PER THE DIRECTION OF A GEOTECHNICAL ENGINEER.
 - BACKFILL TO AT LEAST 300mm ABOVE TOP OF PIPE WITH GRANULAR "A" OR SAND.
 - TO MINIMIZE DIFFERENTIAL FROST HEAVING, TRENCH BACKFILL (FROM PAVEMENT SUBGRADE TO 2.0m BELOW FINISHED GRADE) SHALL MATCH EXISTING SOIL CONDITIONS.
 - SEWERS AND CONNECTIONS 150mm DIAMETER AND SMALLER TO BE PVC SDR 28 OR APPROVED EQUIVALENT. SEWERS AND CONNECTIONS LARGER THAN 200mm DIAMETER AND LESS THAN 450mm DIAMETER TO BE PVC SDR 35 OR APPROVED EQUIVALENT. SEWERS AND CONNECTIONS 450mm DIAMETER AND LARGER TO BE CONCRETE CL 65-D OR APPROVED EQUIVALENT.
 - INSULATE ALL STORM AND SANITARY SEWERS/SERVICES THAT HAVE LESS THAN 1.5m OF COVER WITH THERMAL INSULATION.
 - SUPPLY AND INSTALL ALL PIPING AND APPURTENANCES AS SHOWN AND DETAILED TO WITHIN 1m OF BUILDING. ALL ENDS OF SERVICES TO BE PROPERLY CAPPED AND LOCATED WITH 2"x4"x8" LONG MARKER.
 - CONTRACTOR TO TELEVISION (CCTV) ALL PROPOSED SEWERS ONSITE, OUTLET CONNECTION TO THE MAIN AND PIPES 150mm Ø OR GREATER PRIOR TO BASE COURSE ASPHALT. UPON COMPLETION OF CONTRACT, THE CONTRACTOR IS RESPONSIBLE TO FLUSH AND CLEAN ALL SEWERS & APPURTENANCES.
 - DYE TESTING IS TO BE COMPLETED ON SANITARY SERVICE TO CONFIRM PROPER CONNECTION TO THE SANITARY SEWER MAIN.
 - ALL CATCHBASIN AND CATCHBASIN MANHOLE LEADS ARE TO BE MINIMUM 200mm Ø, CITY MINIMUM 1.0% SLOPE UNLESS OTHERWISE NOTED. ALL CATCHBASINS EXCLUDING LANDSCAPE CATCHBASINS TO HAVE 150 mm Ø PERFORATED PIPE FOR 3.0m ON ALL AVAILABLE SIDES AS PER CITY OF OTTAWA STANDARD DRAWING 'R1'.
- WATERMAIN NOTES**
- CONSTRUCT ALL WATERMANS AND APPURTENANCES IN ACCORDANCE WITH OPSD STANDARDS AND SPECIFICATIONS AS WELL AS CITY OR TOWNSHIP STANDARDS AS INDICATED.
 - WATERMANS AND/OR WATER SERVICES ARE TO HAVE A MINIMUM COVER OF 2.4m. OTHERWISE THERMAL INSULATION IS REQUIRED AS PER CITY OF OTTAWA STANDARD DRAWING 'W22'.
 - IF THE WATERMAIN MUST BE DEFLECTED TO MEET ALIGNMENT, ENSURE THAT THE AMOUNT OF DEFLECTION USED IS EQUAL TO OR LESS THAN THAT WHICH IS RECOMMENDED BY THE MANUFACTURER.
 - USE APPROVED SADDLE CONNECTION WITH MAIN (CORPORATION) STOP AS PER CITY OF OTTAWA STANDARD DRAWING 'W26'.
 - CONNECTION TO EXISTING BY CITY OR TOWNSHIP FORCES. EXCAVATION, BACKFILLING AND REINSTATEMENT IS TO BE COMPLETED BY THE CONTRACTOR.
 - THERMAL INSULATION OF WATERMANS AT OPEN STRUCTURES AS PER CITY OF OTTAWA STANDARD DRAWING 'W22'.
 - THERMAL INSULATION OF WATERMANS UNDER ROAD SIDE DITCHES AS PER CITY OF OTTAWA STANDARD DRAWING 'W21'.

FIRE HYDRANT COVER TABLE

LOCATION	STATION	FINISHED GRADE PHASE 1	TOP OF PIPE	DEPTH
TANK	0+000	114.26	111.86	2.40
HYDRANT #1	0+002.07	114.29	111.89	2.40
HYDRANT #2	0+000	114.41	112.01	2.40
T CONNECTION	0+039.23	114.52	112.12	2.40
HYDRANT #3	0+043.66	115.07	112.67	2.40
	0+045.11	115.04	112.64	2.40
T CONNECTION	0+000	115.07	112.67	2.40
HYDRANT #4	0+085.04	115.18	112.78	2.40

STM NETWORK STRUCTURE TABLE

NAME	RIM ELEV.	INVERT IN	INVERT OUT	DESCRIPTION
CB#9	114.30		E113.100	OPSD 705.010 FRAME 704.010 COVER S19.1
CBMH#2	112.32	SE111.582	NW111.560	OPSD 701.010 FRAME S25 COVER S19
CBMH#3	112.55	NE111.904	NW111.980	OPSD 701.010 FRAME S25 COVER S19
CBMH#7	115.22	W112.654 SE112.475	S112.530	OPSD 701.010 FRAME S25 COVER S19
CBMH#8	114.71	W112.955	E112.930	OPSD 701.010 FRAME S25 COVER S19
CBMH#10	114.36	E112.610	NW112.590	OPSD 705.010 FRAME 704.010 COVER S19.1
LSCB#0	113.74	E113.100	W113.088	LANDSCAPE "T" S30
LSCB#1	112.58	SE111.433	NW111.420	LANDSCAPE "T" S30
LSCB#4	114.11	N112.110	SW112.100	LANDSCAPE "T" S30
LSCB#5	114.40	NW112.306	S112.290	LANDSCAPE "T" S30
LSCB#6	115.10	N112.416	SE112.400	LANDSCAPE "T" S30
LSCB#11	114.00		W112.700	LANDSCAPE "L" S31

01	ISSUED FOR SITE PLAN CONTROL	JAN 20, 2017
No.	Revision/Issue	Date

Check and verify all dimensions before proceeding with the work. Do not scale drawings.

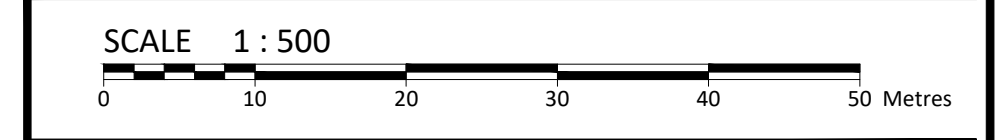

McINTOSH PERRY **MP**

115 Walgreen Road R.R. #3, Carp, ON K0A 1I0
Tel: 613-836-2184 Fax: 613-836-3742

Stamp: **R. P. KENNEDY** LICENSED PROFESSIONAL ENGINEER 100990784 PROVINCE OF ONTARIO

Client: **BBS CONSTRUCTION (ONTARIO) LTD.**
1805 WOODWARD DRIVE OTTAWA ON, K2C 0P9 P: 613-226-8830 F: 613-226-7709

Project: **210/220 MAPLE CREEK COURT WALL SOUND PROPOSED WAREHOUSE DEVELOPMENT**
OTTAWA ONTARIO

Drawing Title: **SITE SERVICING AND UTILITY PLAN**

Scale: 1:500 Project Number: **CP-15-0429**

Drawn by: **CDH**

Checked By: **RPK/CJM** Drawing Number:

Designed By: **JMJ** SHEET 2 of 3

Date: **NOV 25, 2016** **C102**

FILENAME: I:\300-1504-01-1-ProposedWarehouse-Perry-Phase4\CP15-0429-BBS_Site_Plan_210 Maple Creek Court\Civil15 - Drawing\CP15-0429 - PRESENTATION.dwg
 LAST SAVED: Friday, January 20, 2017 1:51:56 PM (BY: jporter)
 LAST PLOTTED: Friday, January 20, 2017 1:53:10 PM (BY: jporter)