

9' X 19' "PARACHUTE" BICYCLE SHELTER **DUO-GARD** FORCE AHEAD

- NOTES:
- Framework to be welded and mechanically fastened steel
 - All mechanical connections to be made with concealed fasteners
 - Rafter and purlin shall be beveled, then capped, welded and ground smooth prior to finishing
 - Base anchor plates shall be stainless steel, grade 304, finished to match shelter
 - Roof glazing to be 8MM structural polycarbonate - battin system
 - See section 10 72 43 for detailed written specifications
 - Design is preliminary, conceptual, and subject to change based on final engineering phase.

FOUNDATION DETAILS NTS

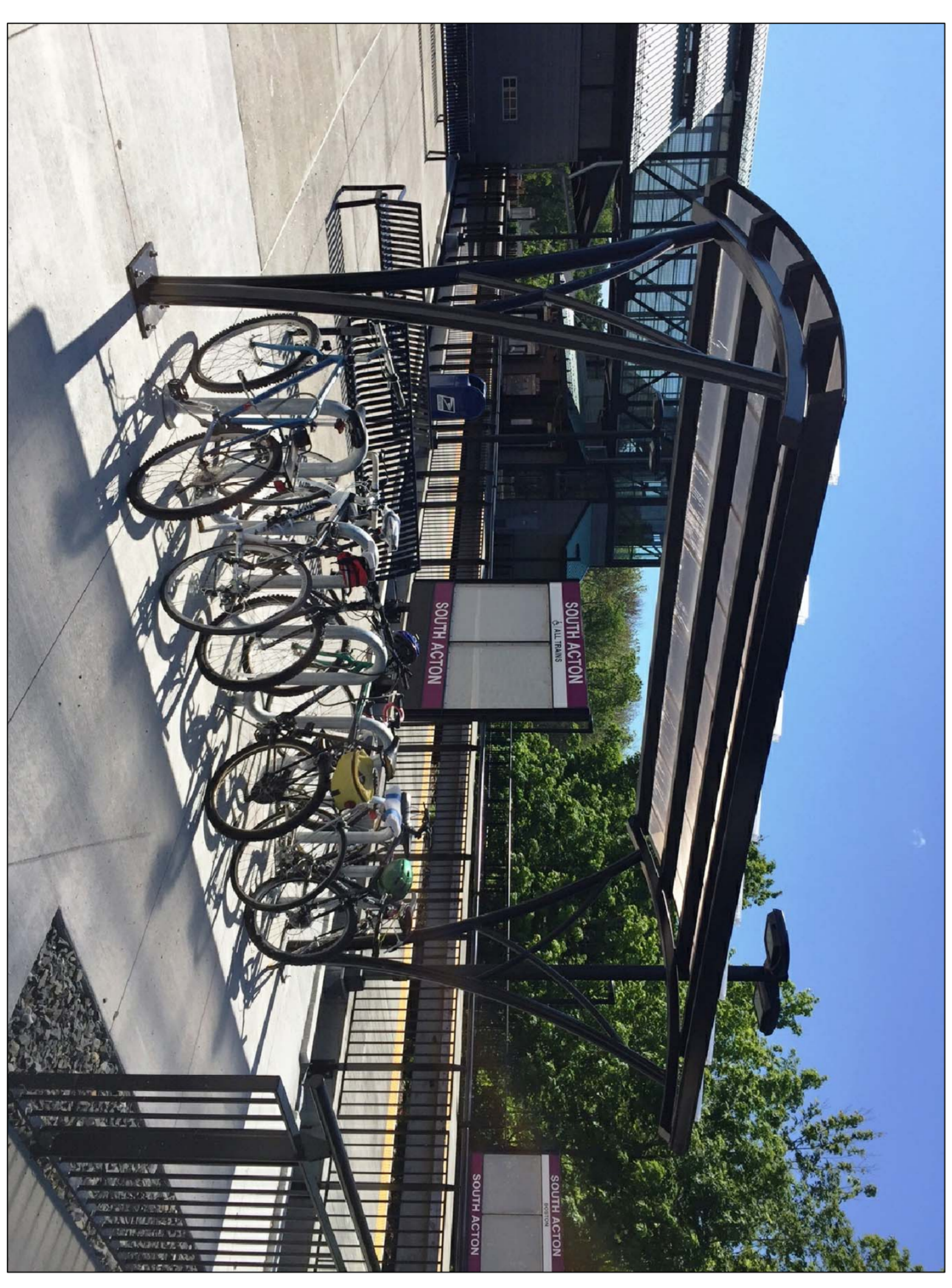
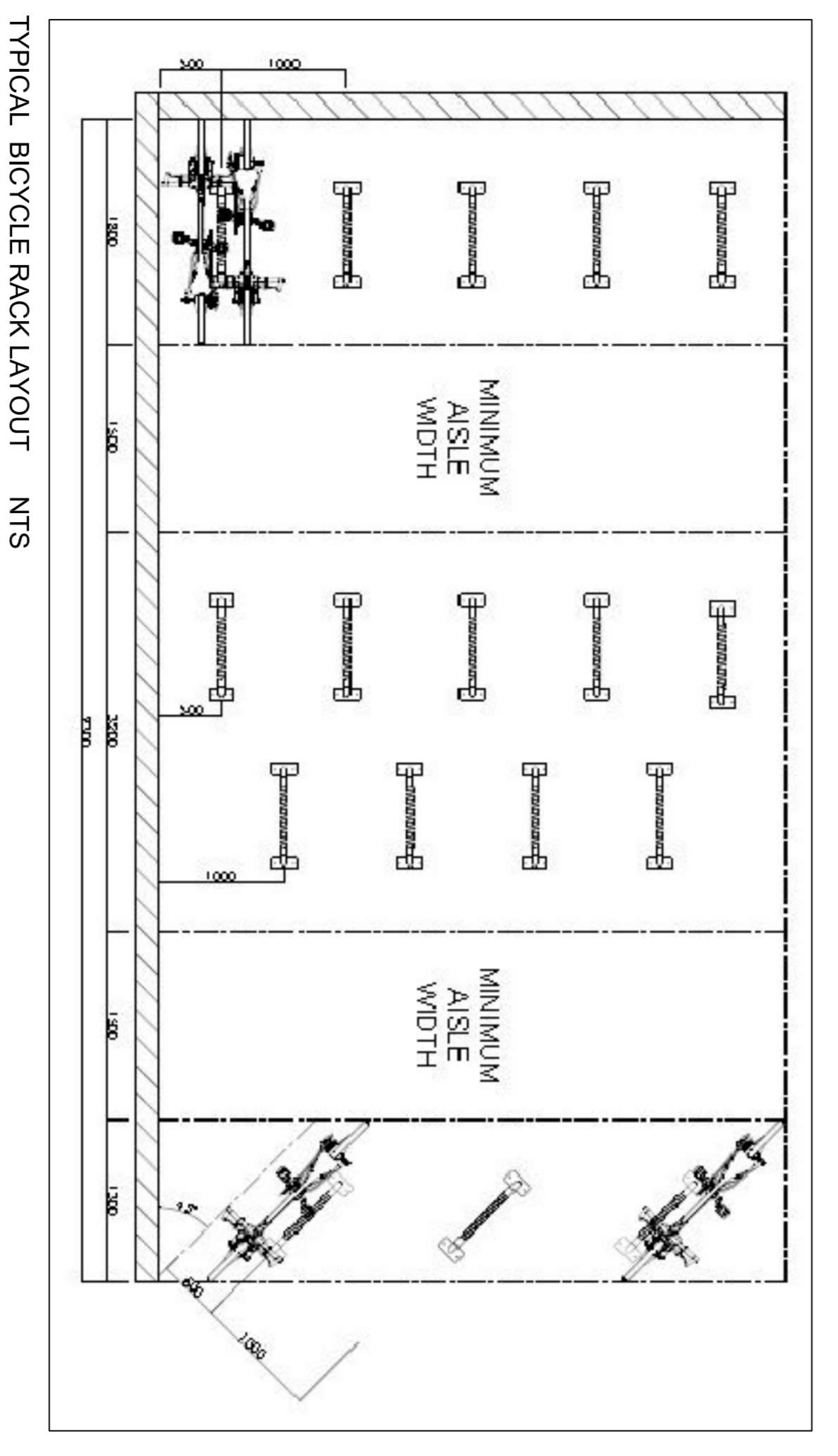
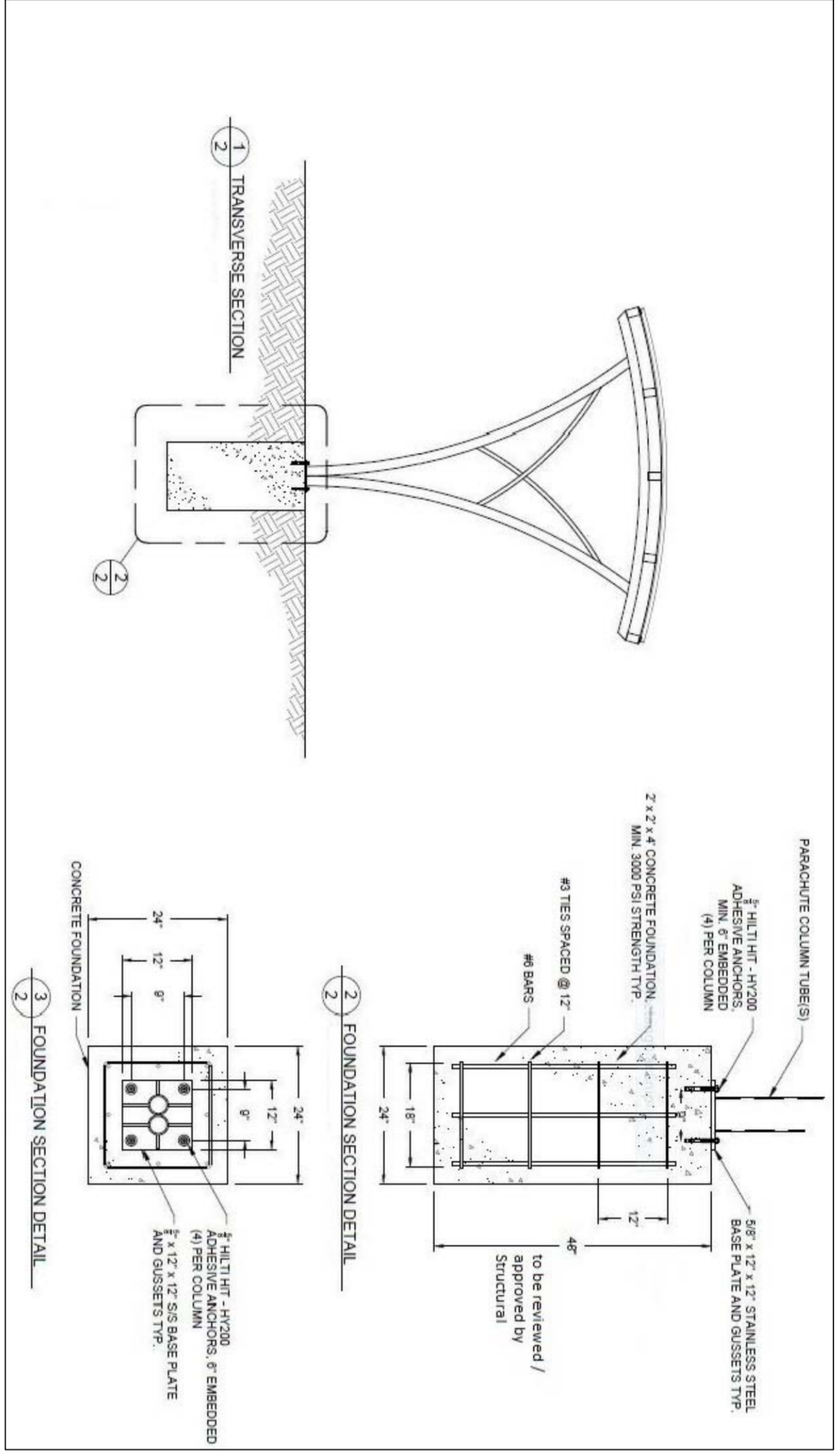

1 BICYCLE SHELTER NTS

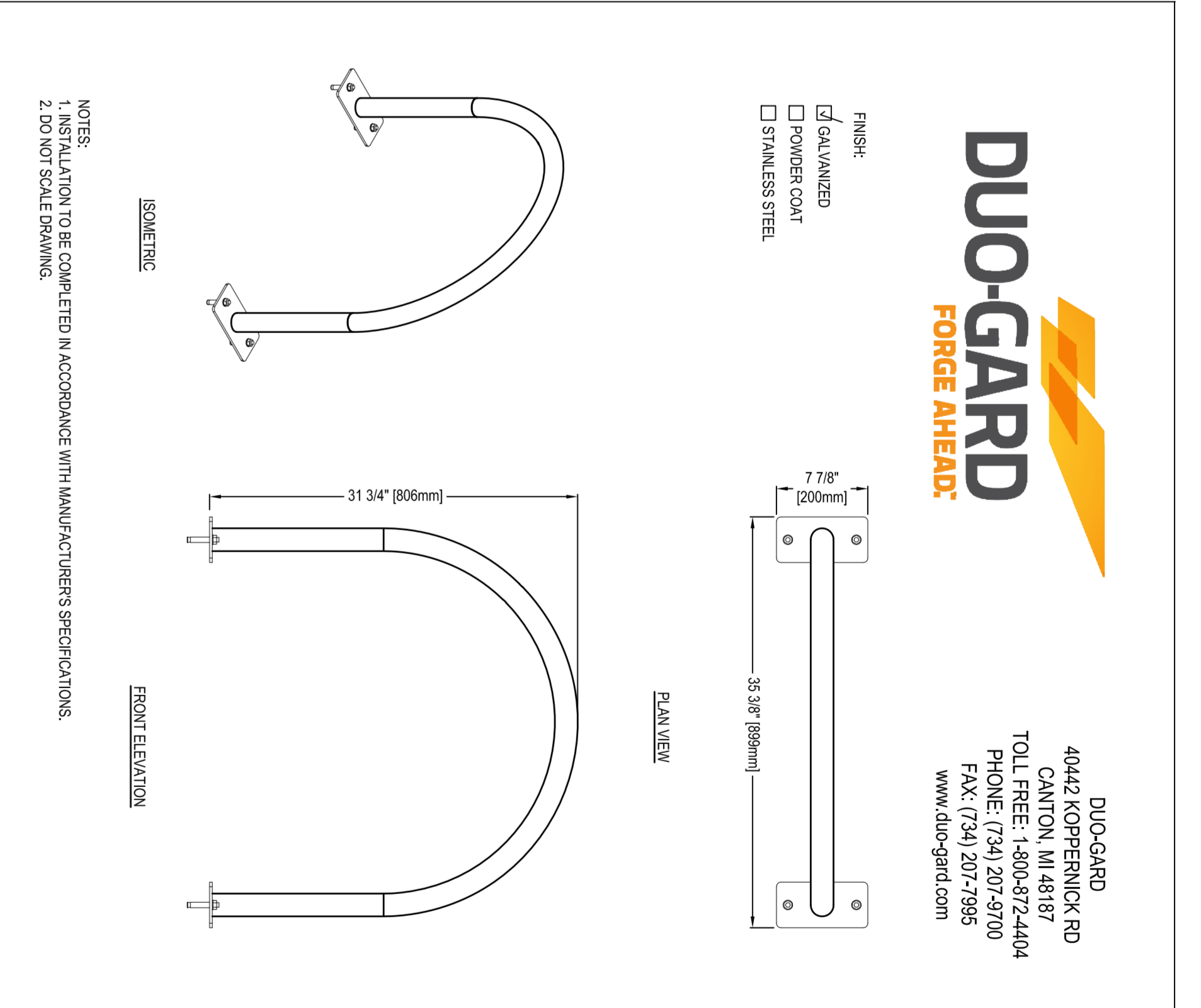

2 BICYCLE RACK NTS

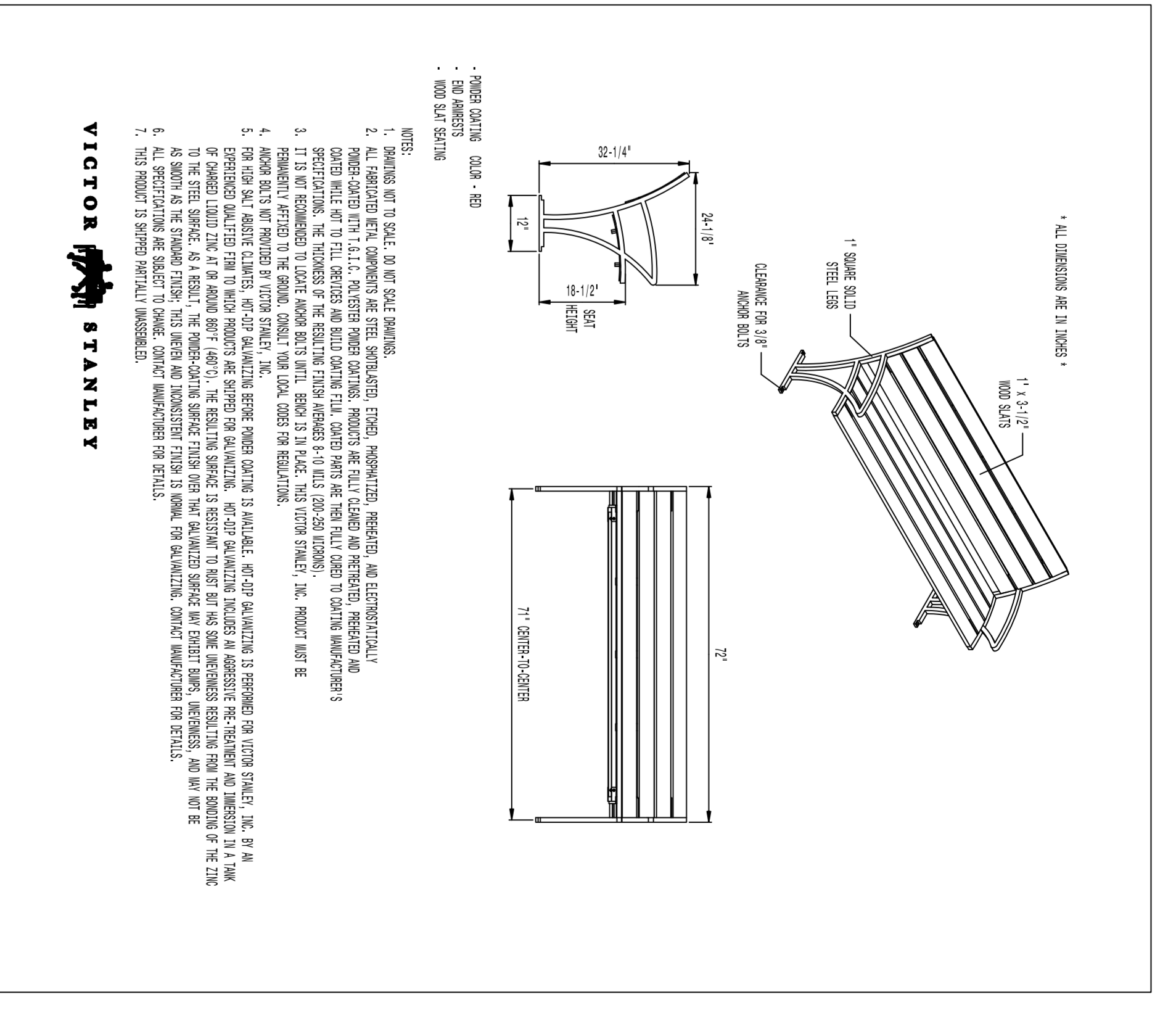

3 BENCH NTS

MARK YOUNG, MCP, APP
 (A) MANAGER, DEVELOPMENT REVIEW - WEST
 PLANNING, INFRASTRUCTURE & ECONOMIC
 DEVELOPMENT DEPARTMENT, CITY OF OTTAWA

APPROVED
 By Laurel McCreight at 8:04 am, Jun 15, 2019

NOT FOR CONSTRUCTION

NO. 1	DATE	REVISION
1	NO. 1	NO. 1
2	NO. 2	NO. 2
3	NO. 3	NO. 3

LEVSTEK CONSULTANT

1887 HURON STREET, SUITE 1000, OTTAWA, ONTARIO K1A 1R8

4044 KOPPERNICK RD
 CANTON, MA 01817
 TOLL FREE: 1-800-872-2404
 FAX: (734) 207-2855
 www.duo-gard.com

DUO-GARD
 FORCE AHEAD

4044 KOPPERNICK RD
 CANTON, MA 01817
 TOLL FREE: 1-800-872-2404
 FAX: (734) 207-2855
 www.duo-gard.com

1300 JUN 2019 1161 L2 01