



**Structural
Environmental
Services**

FIRE FLOW ASSESSMENT REPORT

8520 McArton Road, Ottawa

Prepared by

EAU Structural & Environmental Services

Ottawa, Ontario, K1Y 4P9
Phone: 613 869 0523
Email: derrick.r.clark@rogers.com

Revision 3
June, 2023

1 Project Description:

1.1. Introduction:

The property at 8520 McArton Road is located close to intersection of Upper Dwyer Hill Road and McArton Rd. The existing lot is 7 hectare, currently, 0.863 hectare is proposed for development. This report will address the fire flow requirements associated with the proposed development located at 8520 McArton Road within the City of Ottawa boundary.

1.2. Existing Conditions:

The proposed development measures a total area of approximately 0.863 hectare. The site is located close to the intersection of McArton Road and Upper Dwyer Hill Road in short distance to Highway-7. The closest fire station to 8520 McArton Road is located at 3447 Old Almont Road which within about 5Km radius from the site. The closes approved water source is a storm pond at the south Highway 7 within 1.5Km distance.

The fire station located at 3447 Old Almont Road is a certified superior tanker shuttle under FUS certificate which means they can provide 400 gallons per min within 5 km radius or 5min based on Fire Underwriters Survey.



2 Fire Fighting Requirement
Based on Fire Underwriter Survey Method

Fire flow protection requirements were calculated as per the Fire Underwriter's Survey (FUS).
 An estimate of the fire flow required is as follows:

Step 1:

$$F = 220C\sqrt{A}$$

F = fire flow in liters per minute

C = co-efficient related to type of construction.

= 0.6 for fire resistive construction material

A = Effective floor area in square meters. The building is sub-divided into two relatively equal sections. Vertical fire wall with a fire-resistance rating of 2 hours installed between the two sub-divisions. There is no opening between the two sections except a fire-rated wall. The effective area is considered as 310 m².

Step 2:

Reductions due to non-combustible contents = -15%

Step 3:

Reduction for automatic sprinkler protection

= no sprinkler system

= no change

Step 4:

Charge for structures exposed within 45 meters of separation.

Side	Separation (m)	Charge %
North (rear)	45	20
South (front)	45	20
East (side)	45	20
West (side)	45	20
Total Charge		80

Total Required Fire Flow shall be rounded to the nearest 1000 L/min. Please see calculation in below spreadsheet.

Fire Flow Calculations as per Fire Underwriter's Survey Guidelines

F=220C√A

Address: 8520 McArton Road

where

File No.:

- F= Required fire flow in L/min
- C= Coefficient related to the type of construction
- A= Total floor area in m²

C	Coefficient Related to Type of Construction			C-Value
	• Wood Frame Construction	<input type="checkbox"/>		1.5
	• Ordinary Construction	<input type="checkbox"/>		1.0
	• Non-Combustible Construction	<input type="checkbox"/>		0.8
	• Fire-Resistive Construction	<input checked="" type="checkbox"/>		0.6
			C =	0.6
A	Effective Floor Area (m ²)			
	3340 ft ²	◀ ▶	310.30 m ²	
F	Required Fire Flow (L/min)			
	= 220-C-√A			
	= 2325 L/min			

Occupancy Reductions or Surcharges

- Non-Combustible -25%
- Limited Combustible -15%
- Combustible 0%
- Free Burning 15%
- Rapid Burning 25%

1744 L/min

Sprinkler Reduction

- Adequately Designed System -30%
 - Water Supply is Standard -10%
 - Fully Supervised System -10%
- 0%

Reduction: $\frac{1744 \text{ L/min} - 0 \text{ L/min}}{1744 \text{ L/min}}$

Exposure Surcharge

Distance	Charge	# of Sides	
• 0 to 3m	25%		
• 3.1 to 10m	20%		
• 10.1 to 20m	15%		
• 20.1 to 30m	10%		
• 30.1 to 45m	5%	4	<u>20%</u>
			<u>20%</u>

Surcharge: $\frac{1744 \text{ L/min} + 349 \text{ L/min}}{1744 \text{ L/min}}$

Fire Flow: 2093 L/min

REQUIRED FIRE FLOW

Cannot exceed 45,000 L/min nor be less than 2,000 L/min

2093 L/min
or
35 L/s
or
460 IGPM

Based on calculation, 460 Imperial gallons required.

In order to benefit from local certified superior tanker shuttle fire station, two conditions shall be satisfied based on the Fire Underwriters Survey.

- a) The site shall be within 5Km or 5 min from the local certified superior tanker shuttle fire station
- b) The site shall be within 2.5Km of an approved water source

Proposed development, 8520 McArton Road, is located within 5 km radius or 5min from a fire station located at 3447 Old Almont Road which is a certified superior tanker shuttle under FUS certificate, refer to the correspondents in appendix C. Also, located within 1.5Km of an approved water source which is a storm pond at the south Highway 7. This means that the proposed site is within the umbrella of the fire protection and can benefit from the existing fire department facility.

Based on FUS, certified superior tanker shuttle will provide 400 gallons / min [25.2 L/Sec] for commercial properties. As such the required 460 IGPM [29 L/Sec] for this site can be reduced to $(460 \text{ IGPM} - 400 \text{ IGPM}) = 60 \text{ IGPM}$ [3.75 L/Sec] per each hour. Therefore a tank with the capacity of 3600 gallons [13627.48 L] would be satisfactory for the proposed development. However, an email from the City of Ottawa official, dated February 14, 2023, instructed us that the minimum storage tank acceptable is 10,000 imperial gallon (refer appendix C for the correspondence). Therefore, we will follow the recommendation of the City of Ottawa. We propose a storage tank with the capacity of 10,000 imperial gallon for this development.

3 General Fire Tank Specifications:

- **Storage Tank:**

The storage tank shall be constructed as per the standards and regulations of the City of Ottawa. Since the required water for this development is supplied by artesian well the storage tank will be fitted with on and off floats. This means the storage tank will remain full until there is a demand of water from the storage.

The storage tank shall be designed by a structural engineer and its mechanical components such as pump, on/off floats etc. shall be designed by a qualified mechanical engineer. The tank configuration would be as per the drawings shown on appendix B. A 90-degree elbow will be installed directing inflow into the tank. There is to be a 100mm dia. adapter on the outside enabling the firefighters to reach and use during firefighting operations. Please refer to appendix B for standard drawings of the storage tank.

Based on the geotechnical report, prepared by Terrapex Environmental Ltd., Dated September 08, 2021, the groundwater table is approximately 1m deep in normal seasonal times. In wet times, the groundwater could, conceivable, be at grade. Refer to the groundwater table on page 5 of the geotechnical report. Since the ground water table is high, there is a risk of freezing in the cold season and also floatation of the tank in the wet season. As such the following mandatory recommendations shall be respected for the storage tank:

- The tank shall be fully sealed
- The tank shall insulated and protected against the frost
- The tank shall be designed to resist floatation

- The tank shall be designed to resist the active earth pressure and lateral hydrostatic pressure
- The water within the tank should contain a nonflammable antifreeze to avoid freezing of the contents of the tank. The “antifreeze” shall be an approved product for the fire extinguisher.

- **Hydrant:**

The hydrants for the storage tank shall follow the City of Ottawa standard W51-W54. Based on the geotechnical report, prepared by Terrapex Environmental Ltd., dated September 08, 2021, the groundwater table is shallow, about 1m deep in average. Refer to the groundwater table on page 5 of the geotechnical report. As such, the following mandatory recommendations shall be respected:

- The hydrant shall be as per the City of Ottawa standard hydrant drawing W51-W54 with sealed weep-holes.
- After use of the hydrant, the hydrant shall be cleaned out and the vertical riser shall be pumped out to remove the water. A signage shall be posted on the hydrant to explain this procedure.
- After each use of the hydrant and water tank, the entire system shall be inspected by a certified inspector.

We hope our report satisfies all your requirements. Should you have any questions, please do not hesitate to contact us.



Yours truly,
Derrick R. Clark, P. Eng.

Guidelines, Previous Studies,

The following studies were utilized in the preparation of this report:

- Ottawa Design Guidelines Water Distribution
City of Ottawa, July 2010. (Water Supply Guidelines)
- Water Supply for Public Fire Protection,
Fire Underwriters Survey 2020
- Ontario Building Code Compendium
Ministry of Municipal Affairs and Housing Building Development Branch,
January 1, 2012 Update. (OBC)

APPENDIX A:

GeoOttawa Map

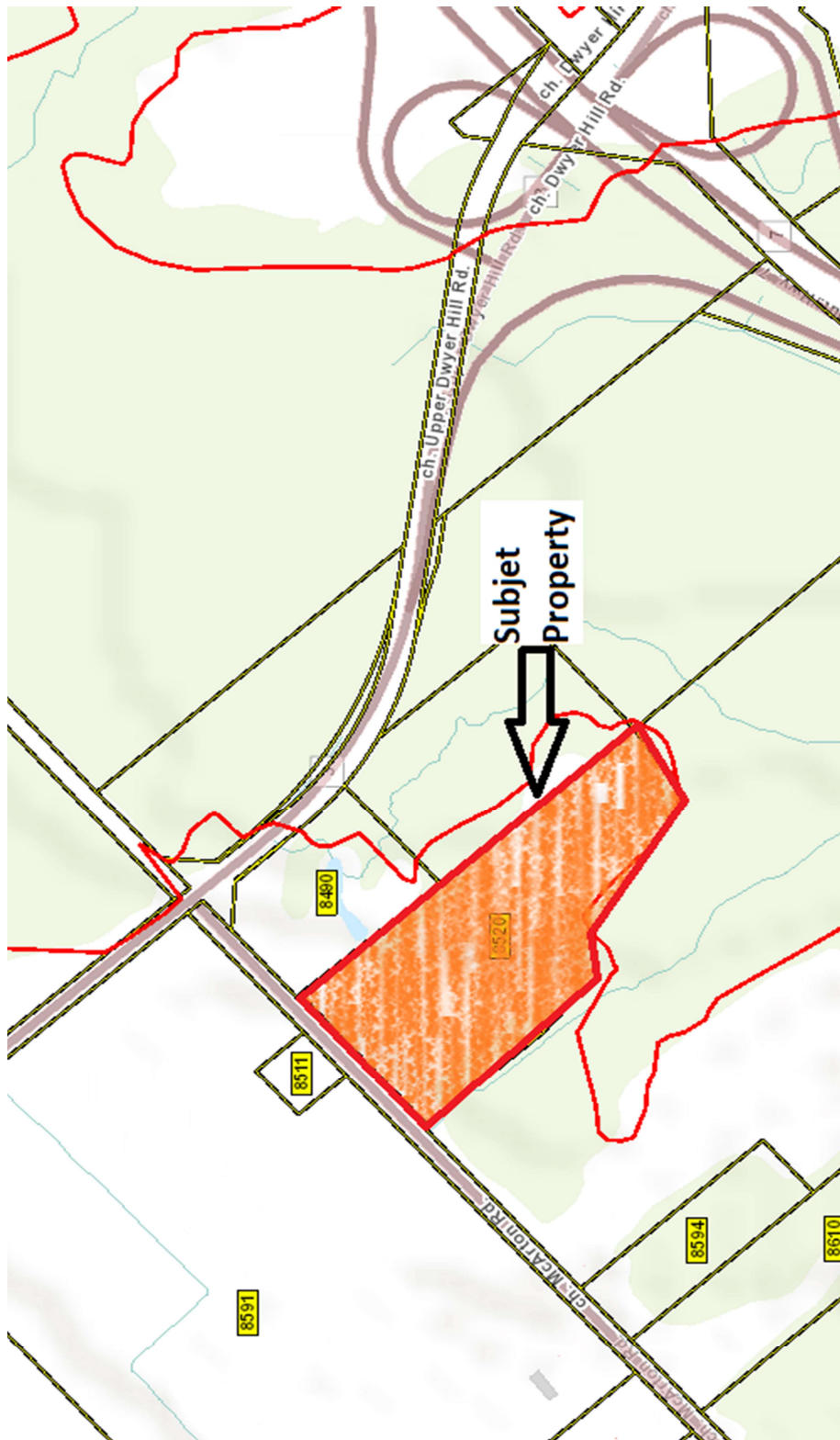

APPENDIX B:

Standard Storage Tank and Hydrant

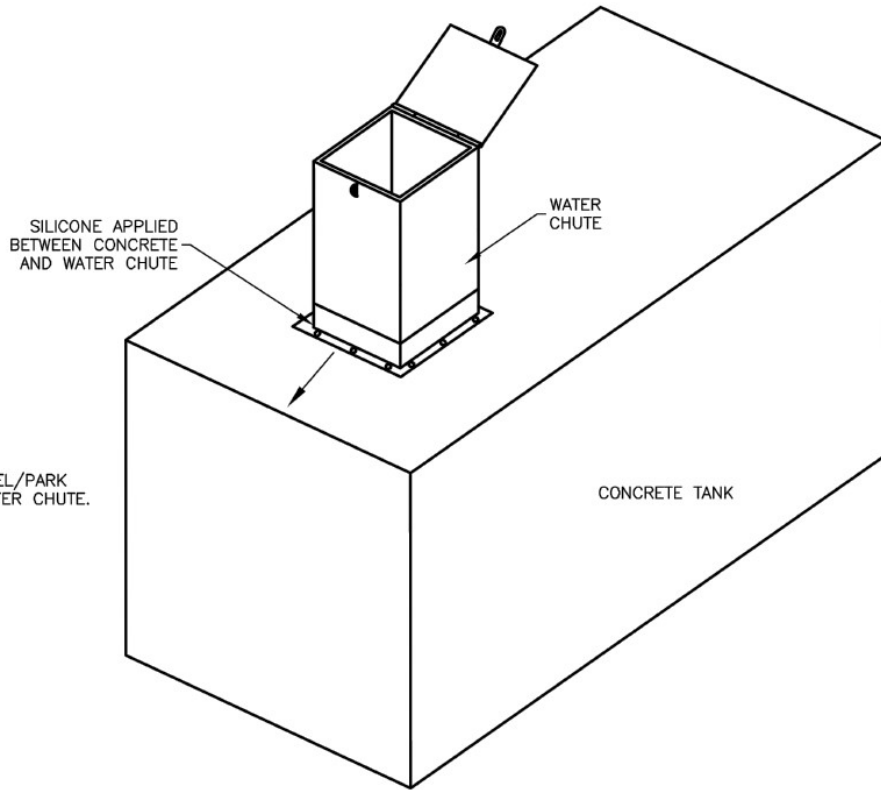

NOTE:
FIRE VEHICLE MUST TRAVEL/PARK
WITHIN 1.0m OF THE WATER CHUTE.

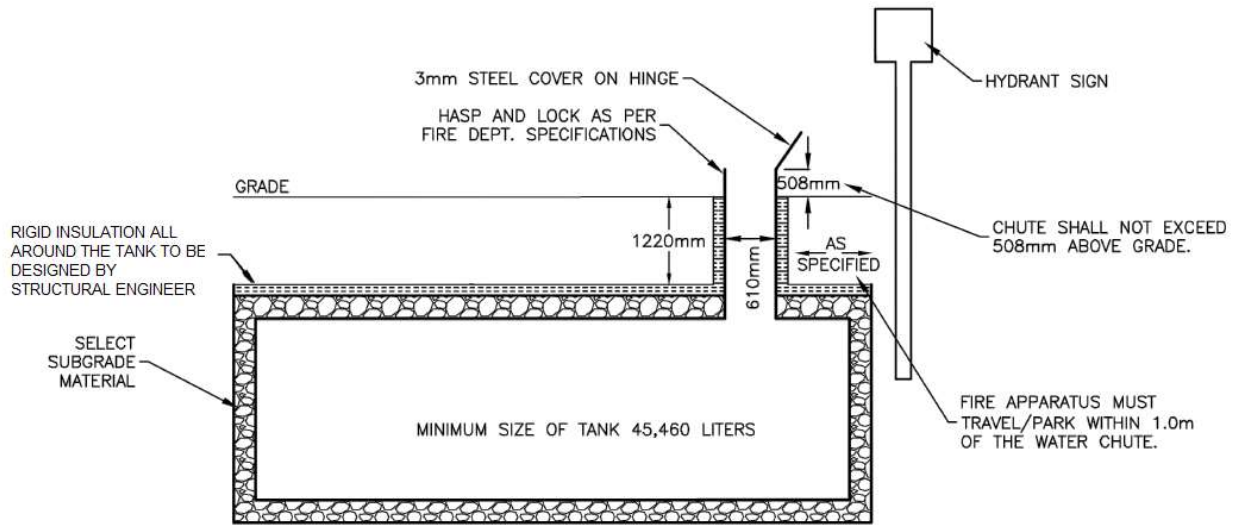

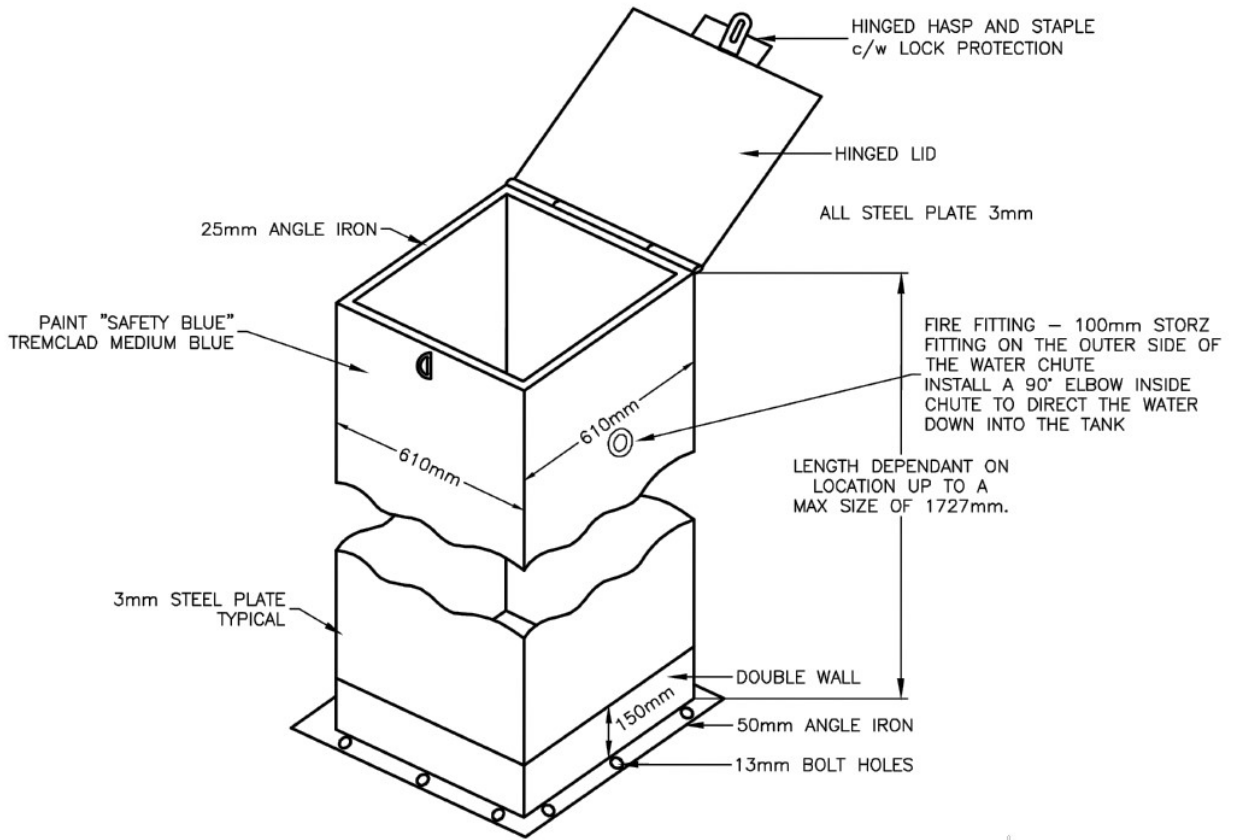

NORTHLINE 6NH FEMALE THREAD,
INTERNAL STRAINER ROCKER LUG
THREADED PLUG WITH CHAIN
CONFIGURED IN A 90° SCHEDULE
40 PVC ELBOW.

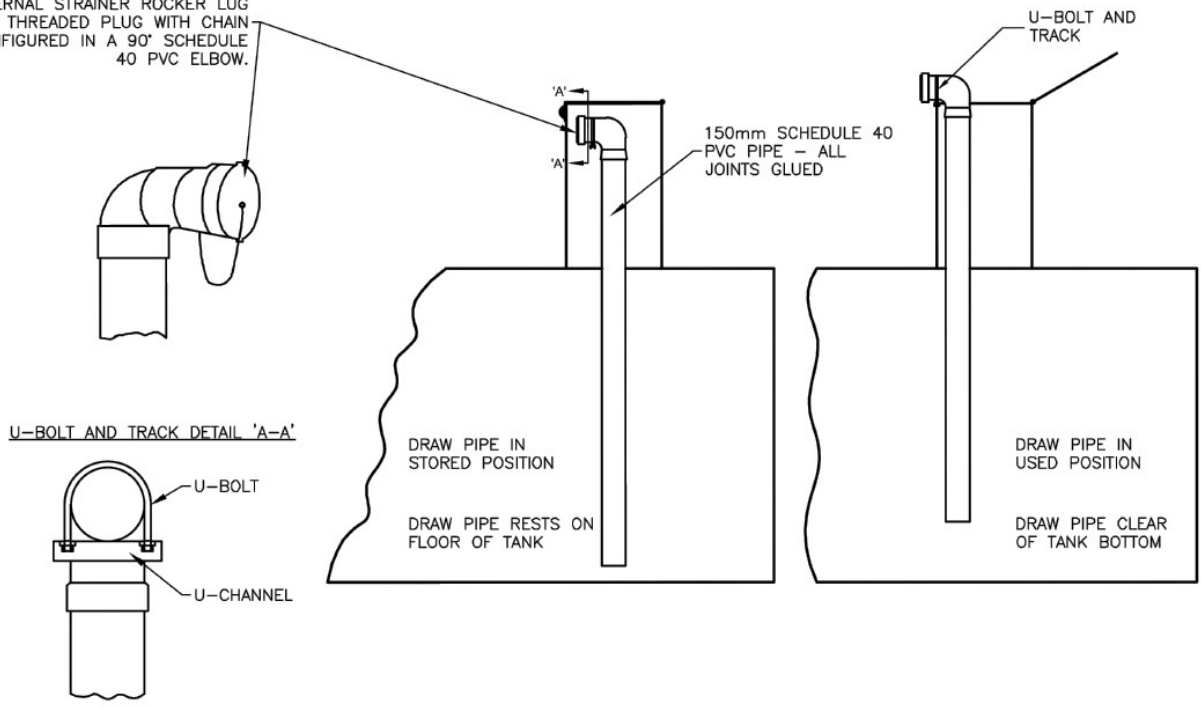

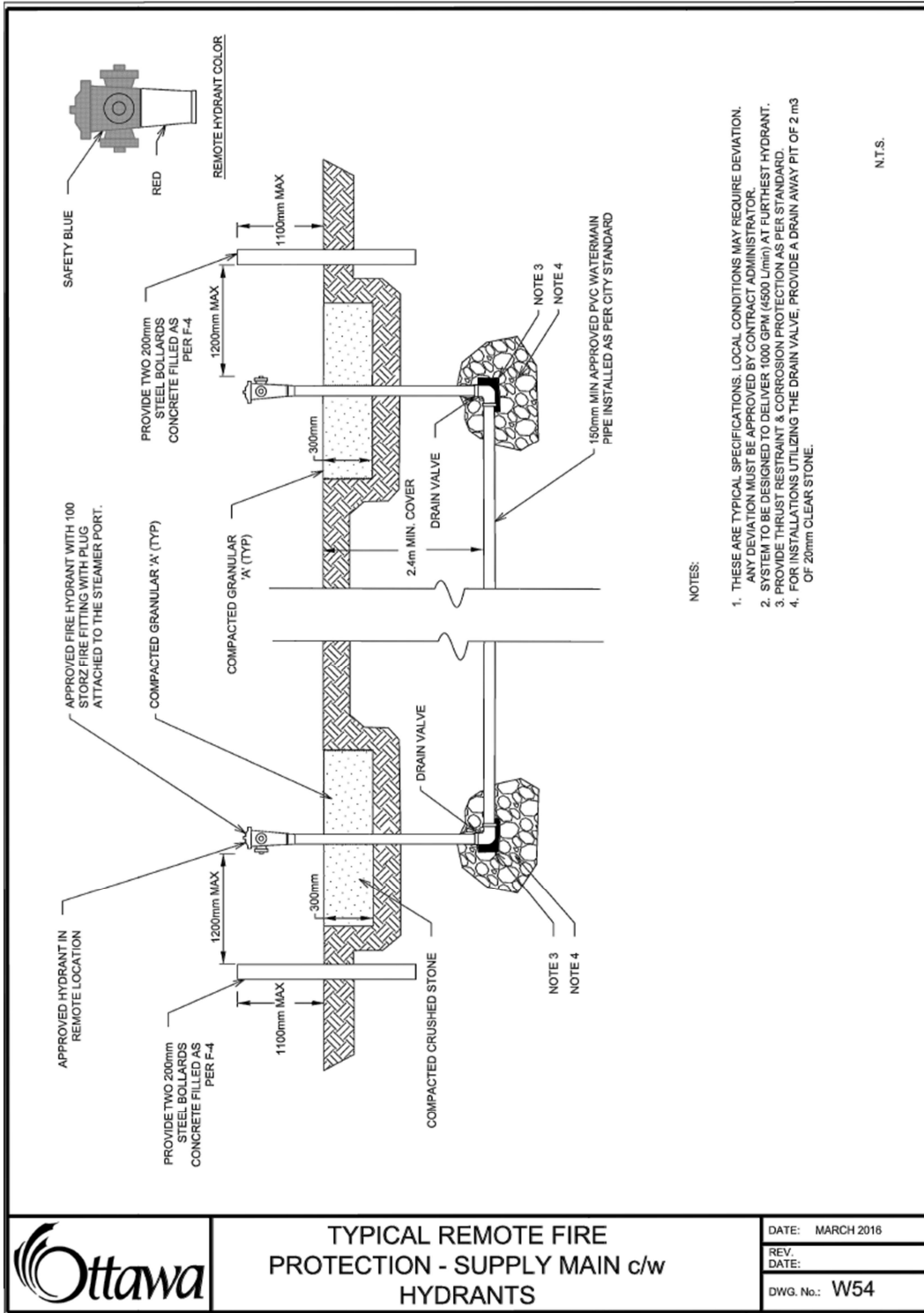

APPENDIX C:
Correspondents and Records

RE: FW: File: D07-12-19-0145 (Ottawa Valley Wild Bird Care Centre)

1 message

Evans, Allan <Allan.Evans@ottawa.ca>

23 June 2023 at 14:46

To: EAU Services <eau.services.ottawa@gmail.com>

Cc: "juliette@wildbirdcarecentre.org" <juliette@wildbirdcarecentre.org>, "Harrigan, Sean" <sean.harrigan@ottawa.ca>, "Roy, Larry" <larrym.roy@ottawa.ca>

Hi – yup that's exactly what we would recommend. Fire Hydrant with sealed weep holes and we will have to add some sort of note on our end (and probably some signage at the site) that after use the vertical riser has to be pumped out to remove the water. There will be requirements for strapping down the tank, etc.

We do have these types of hydrants installed elsewhere, but typically in an unlimited (ie: river/large pond) water source. I'm guessing you don't want to go with the W51 blue box and loose pipe inside then (totally fine either way).

Allan Evans

Fire Protection Engineer / Ingénieur de Protection d'Incendies

Prevention Division / Prévention des Incendies

Ottawa Fire Services / Service des Incendies d'Ottawa

1445 Carling Avenue / 1445 Avenue Carling

Ottawa, ON K1Z 7L9

Allan.Evans@Ottawa.ca

☎ (613) 913-2747 | ☎ (613) 580-2424 x24119 | 📠 (613) 580-2866 | 📧 Mail Code: 25-102 | @OFSFPE



OTTAWA FIRE SERVICES
SERVICE DES INCENDIES D'OTTAWA
*Protecting Our Nation's Capital With Pride
Protéger notre capitale nationale avec fierté*



An internationally accredited agency 2014-2019

From: EAU Services <eau.services.ottawa@gmail.com>**Sent:** June 23, 2023 1:22 PM**To:** Evans, Allan <Allan.Evans@ottawa.ca>**Cc:** juliette@wildbirdcarecentre.org; Harrigan, Sean <sean.harrigan@ottawa.ca>**Subject:** Re: FW: File: D07-12-19-0145 (Ottawa Valley Wild Bird Care Centre)

CAUTION: This email originated from an External Sender. Please do not click links or open attachments unless you recognize the source.

ATTENTION : Ce courriel provient d'un expéditeur externe. Ne cliquez sur aucun lien et n'ouvrez pas de pièce jointe, excepté si vous connaissez l'expéditeur.

Hi Allan,

If you remember, we had a previous conversation on this project. Now again back to you on another topic again on this project. This time is about the fire tank.

Based on the geotechnical report, the groundwater table is very high and our water tank may have issues related to freezing during cold weather. We would suggest hydrants with sealed weep holes and insulation of the water tank but wondering if you would be able to let us know what is acceptable from your end. Any City of Ottawa standard drawing for this case scenario or if you remember a similar tank installed somewhere in a high ground water level area.

Much appreciated,

Bob

On Fri, 23 Jun 2023 at 09:26, Harrigan, Sean <sean.harrigan@ottawa.ca> wrote:

Good morning Bob,

Allan Evans (cc'd) is the Engineer contact from Fire Protection Services who provided the latest review comments. Please keep me included on any email correspondence for record keeping purposes.

Regards,

Sean Harrigan

Planner I | Urbaniste I

Development Review | Examen des projets d'aménagement

Planning, Real Estate and Economic Development Department / Direction générale de la planification, des biens immobiliers et du développement économique

City of Ottawa | Ville d'Ottawa

📞 613.580.2424 ext./poste 23489

From: EAU Services <eau.services.ottawa@gmail.com>

Sent: Thursday, June 22, 2023 11:45 PM

To: Harrigan, Sean <sean.harrigan@ottawa.ca>

Cc: juliette@wildbirdcarecentre.org <juliette@wildbirdcarecentre.org>

Subject: Re: FW: File: D07-12-19-0145 (Ottawa Valley Wild Bird Care Centre)

CAUTION: This email originated from an External Sender. Please do not click links or open attachments unless you recognize the source.

ATTENTION : Ce courriel provient d'un expéditeur externe. Ne cliquez sur aucun lien et n'ouvrez pas de pièce jointe, excepté si vous connaissez l'expéditeur.

Hi Sean,

Thanks for your email. For your information, based on the geotechnical report, the groundwater table is very high and our water tank may have issues related to freezing during cold weather. Hydrants with sealed weep holes and insulation of the water tank are the options but wondering if you would be able to provide me with the contact person in the fire department in order to inquire about what is acceptable from their end, in this case scenario?

Much appreciated,

Bob,

From: Harrigan, Sean <sean.harrigan@ottawa.ca>

Sent: Thursday, June 8, 2023 10:09 AM

To: Brown, Adam <Adam.Brown@ottawa.ca>; juliette@wildbirdcarecentre.org

Subject: Re: File: D07-12-19-0145 (Ottawa Valley Wild Bird Care Centre)

Good morning Juliette,

I hope you are doing well.

Thank you for your follow up email and your continued patience. As Adam mentioned, almost all outstanding issues have been resolved, including those related to stormwater management, except for 3 items:

General Comment

1. The Septic Permit has expired as it is only valid for 1 year. We will require a new Septic Permit for the final approval.

Fire Fighting

2. Hydrant type. As we have a draft hydrant, it is important to make sure the correct hydrant is used for the application. It must be capable of drafting (negative pressure) and have the correct adapter on it for our trucks (if W51-W54 have not been provided, please let me know). It is also important to note the water table in this area. If there is a chance that the hydrant bottom (where the pipe goes parallel to the tank) will be within the water line (especially in colder months), the fire hydrant must have sealed weep-holes. If the water table is safely below this level, then a normal operating hydrant is fine. The purpose is that when the hydrant is Closed (prevents water from coming from tank), the weep holes open so that the stem (riser) of the hydrant will drain out the bottom and stays dry – in winter, it will not freeze. If the water table is high, then ground water could rise up and potentially freeze and damage the hydrant.
3. Storage tank filling – how will the 50000L tank be filled? The tank is “remote” which is fine for the draft portion of our operations, but we also have a requirement to be able to fill the tank both during firefighting operations and after we are done at a fire at that location. In a standard

setup, we have a blue box on top of the tank directly and they install a 90 degree elbow directed downwards into the tank with a 100mm storz adapter on the outside (see below). We would connect our hose to this adapter and pump water down into the tank to fill. For this setup, the tank is remote from the draft hydrant. They could provide a fill pipe with adapter at that location sort of adjacent to it and run more pipe back to the tanks, but this could lead to a similar freezing issue with the water level rising within the pipe to the same level as the tank itself. They could also put a pipe with the adapter above the tanks provided we were able to get to it. We have lots of hose to run water to the tanks, we just need the ability to get to those tanks (on foot is fine).

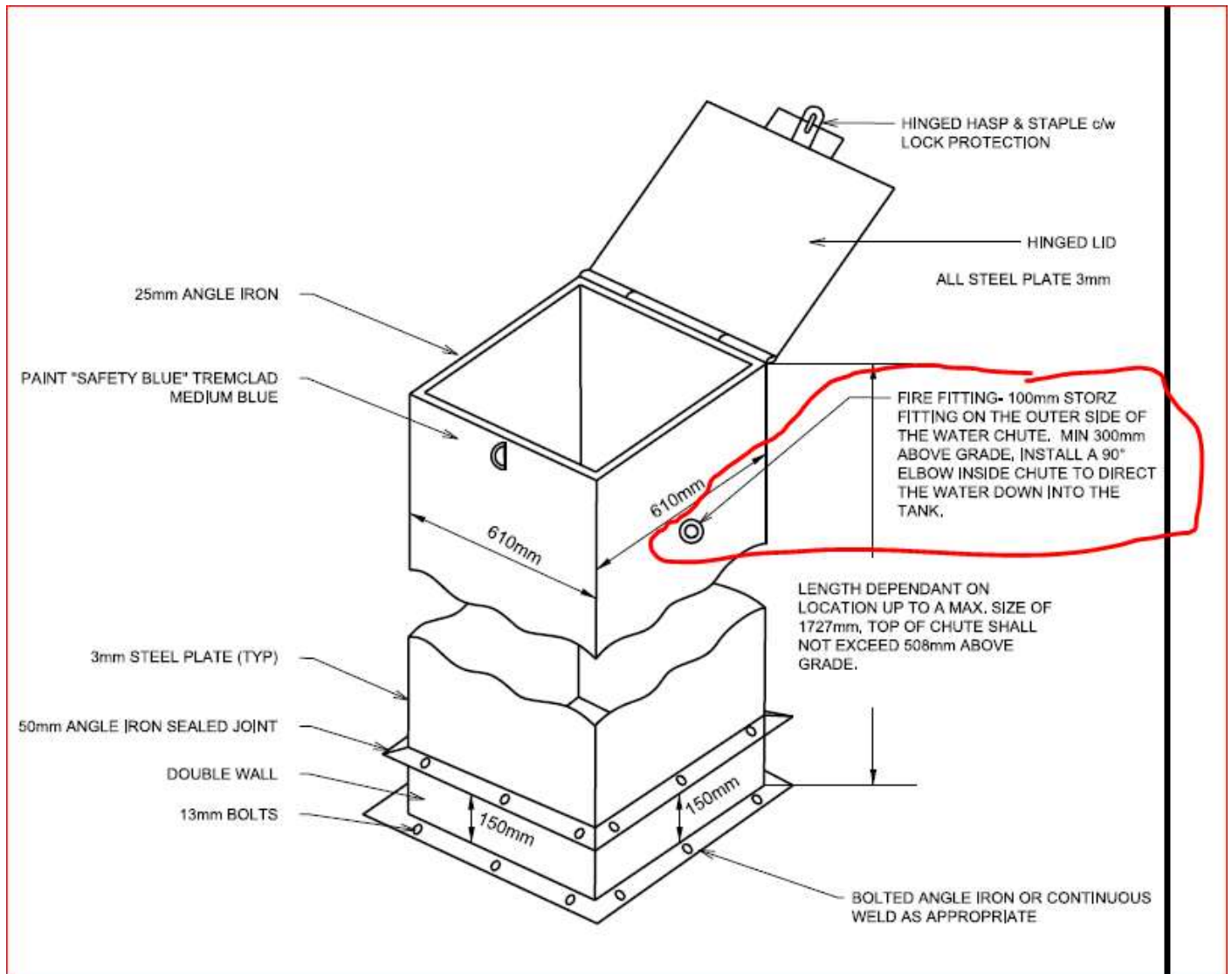

Please note that the two fire fighting comments must be addressed in both the Fire Flow Assessment Report and the Site Servicing Plan, as the Servicing Plan must show the fire hydrant type and location along with any other pipes associated with filling the fire storage tank.

Please let me know if you have any questions.

Kind Regards,

Sean Harrigan

Planner I | Urbaniste I

Development Review | Examen des projets d'aménagement

Planning, Real Estate and Economic Development Department / Direction générale de la planification, des biens immobiliers et du développement économique

City of Ottawa | Ville d'Ottawa

613.580.2424 ext./poste 23489

From: Brown, Adam <Adam.Brown@ottawa.ca>
Sent: Wednesday, June 7, 2023 12:00 PM

To: juliette@wildbirdcarecentre.org <juliette@wildbirdcarecentre.org>
Cc: Harrigan, Sean <sean.harrigan@ottawa.ca>
Subject: RE: File: D07-12-19-0145 (Ottawa Valley Wild Bird Care Centre)

Hello Juliette

While most issues are resolved for your file, Sean had to get sign off from the Fire Services folks about the storage tank. I will ask him to give you and update.

regards,
Adam

From: juliette@wildbirdcarecentre.org <juliette@wildbirdcarecentre.org>
Sent: June 07, 2023 11:36 AM
To: Brown, Adam <Adam.Brown@ottawa.ca>
Subject: File: D07-12-19-0145 (Ottawa Valley Wild Bird Care Centre)

CAUTION: This email originated from an External Sender. Please do not click links or open attachments unless you recognize the source.

ATTENTION : Ce courriel provient d'un expéditeur externe. Ne cliquez sur aucun lien et n'ouvrez pas de pièce jointe, excepté si vous connaissez l'expéditeur.

Hi Adam,

I hope this email finds you well.

Just a quick follow up on our file. Since we sent the last submission on March 20, I was hoping to hear back on it by now. What is the status of our site plan?

Next steps?

Regards,

Juliette

Juliette Marczuk
Chair, Board of Directors
Ottawa Valley Wild Bird Care Centre
C: (613) 291-1137
<https://wildbirdcarecentre.org>

This e-mail originates from the City of Ottawa e-mail system. Any distribution, use or copying of this e-mail or the information it contains by other than the intended recipient(s) is unauthorized. Thank you.

Le présent courriel a été expédié par le système de courriels de la Ville d'Ottawa. Toute distribution, utilisation ou reproduction du courriel ou des renseignements qui s'y trouvent par une personne autre que son destinataire prévu est interdite. Je vous remercie de votre collaboration.

This e-mail originates from the City of Ottawa e-mail system. Any distribution, use or copying of this e-mail or the information it contains by other than the intended recipient(s) is unauthorized. Thank you.

Le présent courriel a été expédié par le système de courriels de la Ville d'Ottawa. Toute distribution, utilisation ou reproduction du courriel ou des renseignements qui s'y trouvent par une personne autre que son destinataire prévu est interdite. Je vous remercie de votre collaboration.

This e-mail originates from the City of Ottawa e-mail system. Any distribution, use or copying of this e-mail or the information it contains by other than the intended recipient(s) is unauthorized. Thank you.

Le présent courriel a été expédié par le système de courriels de la Ville d'Ottawa. Toute distribution, utilisation ou reproduction du courriel ou des renseignements qui s'y trouvent par une personne autre que son destinataire prévu est interdite. Je vous remercie de votre collaboration.



EAU Services <eau.services.ottawa@gmail.com>

RE: OVWBCC questions from City of Ottawa

1 message

juliette@wildbirdcarecentre.org <juliette@wildbirdcarecentre.org>
To: EAU Services <eau.services.ottawa@gmail.com>
Cc: Derrick Clark <derrick.r.clark@rogers.com>

4 March 2023 at 11:46

Thank you, Bob.

I have passed on the information.

Regards,

Juliette

Juliette Marczuk

Chair, Board of Directors

Ottawa Valley Wild Bird Care Centre

C: (613) 291-1137

<https://wildbirdcarecentre.org>

From: EAU Services <eau.services.ottawa@gmail.com>
Sent: Friday, March 3, 2023 10:39 PM
To: juliette@wildbirdcarecentre.org
Cc: Derrick Clark <derrick.r.clark@rogers.com>
Subject: Re: OVWBCC questions from City of Ottawa

Hi Julietter,

I am sorry for the late response as I needed some legal information to respond to the last question. You know how slow is the legal when they are asked for information.

Anyways, here are the answers in **RED** and you can copy/paste to the City official:

- the minimum storage tank that would be acceptable by the City is a 10,000 Imperial gallon tank. (45,460.9 litres) **No issue with that if that is the City rule.**

- all flow rates and volumes must be presented in metric units. **Metric rates and volume are added to the report in brackets. please see revised report attached**

- please provide more information on the 'approved water source ... at the south Highway 7'. Who owns this pond? Do you have legal access? **To the best of my knowledge, the City of Ottawa has a legal agreement number, L01-06-DWYE1229, on title with the owner of the property. Based on this agreement, which is transferable on title, the City of Ottawa has blanket easement access over the entire property of 1229 Dwyer Hill Road for any sort of municipal responsibility. This agreement extends the access to the City of Ottawa Fire Department in case of the emergency. As can be seen on the image below from GeoOttawa, full asphalt road access to the pond is provided for future fire trucks and our project benefits from being in close proximity to this pond.**



- The Senior engineer requests that the report provide clear support for all conclusions made. **Please see the attached.**

On Fri, 3 Mar 2023 at 08:11, <juliette@wildbirdcarecentre.org> wrote:

Hello Bob,

I'm following up today since it has been two weeks since I have heard from you, and we are desperately trying to get this submission through.

Our other civil engineer is waiting for the documentation to confirm support the following:

As per the city E-mail, it is required to provide the following:

- the minimum storage tank that would be acceptable by the City is a 10,000 Imperial gallon tank. (45,460.9 litres)
- all flow rates and volumes must be presented in metric units.
- please provide more information on the 'approved water source ... at the south Highway 7'. Who owns this pond? Do you have legal access?
- The Senior engineer requests that the report provide clear support for all conclusions made.

Please provide the documentation that provides the clear support for the conclusions made as requested by the City of Ottawa.

I ask that you provide me the information no later than Monday, March 6.

Regards,

Juliette

Juliette Marczuk

Chair, Board of Directors

Ottawa Valley Wild Bird Care Centre

C: (613) 291-1137

<https://wildbirdcarecentre.org>

From: EAU Services <eau.services.ottawa@gmail.com>

Sent: Thursday, February 16, 2023 6:03 PM

To: juliette@wildbirdcarecentre.org

Cc: Derrick Clark <derrick.r.clark@rogers.com>

Subject: Re: OVWBCC questions from City of Ottawa

Hi Juliette,

I am referring to storm pond south of highway 7. Any one who owns it, is not important, when it comes to the emergency situation. I did not dig up who owns this pond, likely the City, but there is good access to the pond in order to load up the fire tanks and is very close to your property. I will respond back to the City early next week as I am booked up all day tomorrow.

Regards,



On Thu, 16 Feb 2023 at 10:33, <juliette@wildbirdcarecentre.org> wrote:

Hi Bob,

Are you able to provide the answer the City's questions regarding the "approved water source ... at the south Highway 7" in your report?

Specifically, "Who owns this pond? Do you have legal access?"

To which pond are you referring? From GeoOttawa maps, I can't see public access to a storm pond...

From my end, I'd like to know if/how the calculations change if the access to this approved water source is not possible.

Please explain.

Regards,

Juliette

Juliette Marczuk

Chair, Board of Directors

Ottawa Valley Wild Bird Care Centre

C: (613) 291-1137

<https://wildbirdcarecentre.org>



EAU Services <eau.services.ottawa@gmail.com>

FW: D07-12-19-0145 - 8520 McArton Road - Fire Protection

1 message

juliette@wildbirdcarecentre.org <juliette@wildbirdcarecentre.org>

15 February 2023 at 14:37

To: EAU Services <eau.services.ottawa@gmail.com>, Derrick Clark <derrick.r.clark@rogers.com>

Hi Bob,

I just wanted to pass this information on to you and ask if you would be able to address any new comments regarding the fire calculation.

Thanks.

Regards,

Juliette

Juliette Marczuk

Chair, Board of Directors

Ottawa Valley Wild Bird Care Centre

C: (613) 291-1137

<https://wildbirdcarecentre.org>

From: Morgan, Brian <Brian.Morgan@ottawa.ca>

Sent: Wednesday, February 15, 2023 1:38 PM

To: 'Husham Almansour' <hkhha.adad@gmail.com>; juliette@wildbirdcarecentre.org

Cc: Whittaker, Damien <Damien.Whittaker@ottawa.ca>; Evans, Allan <Allan.Evans@ottawa.ca>; Morgan, Brian <Brian.Morgan@ottawa.ca>; Harrigan, Sean <sean.harrigan@ottawa.ca>

Subject: RE: D07-12-19-0145 – 8520 McArton Road - Fire Protection

RE: D07-12-19-0145 – 8520 McArton Road - Fire Protection

Juliette & Husham,

Dear Juliette & Husham,

I've spoken with Fire Services and - in general - the City accepts the conclusions of the Fire Flow Assessment report (Dec-2022).

However, we have the following comments:

- the minimum storage tank that would be acceptable by the City is a 10,000 Imperial gallon tank. (45,460.9 litres)
- all flow rates and volumes must be presented in metric units.
- please provide more information on the 'approved water source ... at the south Highway 7'. Who owns this pond? Do you have legal access?
- The Senior engineer requests that the report provide clear support for all conclusions made.

Sincerely,

Brian

Brian R. Morgan, CET, IntET(Canada)

Project Manager | Gestionnaire de programme

Development Review - Rural Branch

Planning, Real Estate and Economic Development Department /

Direction générale de la planification, des biens immobiliers et du développement économique

City of Ottawa | Ville d'Ottawa

W: 613.580.2424 ext./poste 13698, E: brian.morgan@ottawa.ca

Due to the City's and public health directions related to COVID-19,

I will be working from home until further notice.

Phone contact is limited and therefore email is the best option.

,
This e-mail originates from the City of Ottawa e-mail system. Any distribution, use or copying of this e-mail or the information it contains by other than the intended recipient(s) is unauthorized. Thank you.

Le présent courriel a été expédié par le système de courriels de la Ville d'Ottawa. Toute distribution, utilisation ou reproduction du courriel ou des renseignements qui s'y trouvent par une personne autre que son destinataire prévu est

interdite. Je vous remercie de votre collaboration.

,

RE: FW: D07-12-19-0145 – 8520 McArton Road: Water Supply for Fire Protection as part of Site Plan Control

1 message

Evans, Allan <Allan.Evans@ottawa.ca>
To: EAU Services <eau.services.ottawa@gmail.com>

12 December 2022 at 13:51

I have also confirmed that we meet superior tanker shuttle for commercial (400 gpm), but the conditions as specified below for distances is required for this to be applicable.

A

*Allan Evans***Fire Protection Engineer / Ingénieur de Protection d'Incendies****Prevention Division / Prévention des Incendies****Ottawa Fire Services / Service des Incendies d'Ottawa****1445 Carling Avenue / 1445 Avenue Carling****Ottawa, ON K1Z 7L9****Allan.Evans@Ottawa.ca**

☎ (613) 913-2747 | ☎ (613) 580-2424 x24119 | ☎ (613) 580-2866 | ✉ Mail Code: 25-102 | @OFSFPE

**OTTAWA FIRE SERVICES**
SERVICE DES INCENDIES D'OTTAWA
Protecting Our Nation's Capital With Pride
Protéger notre capitale nationale avec fierté

An internationally accredited agency 2014-2019

From: Evans, Allan <Allan.Evans@ottawa.ca>**Sent:** December 09, 2022 9:08 AM**To:** EAU Services <eau.services.ottawa@gmail.com>**Subject:** RE: FW: D07-12-19-0145 – 8520 McArton Road: Water Supply for Fire Protection as part of Site Plan Control

Yes – that is within arriving on scene (how fast we can setup and flow water). That is a part of becoming certified under FUS for superior tanker shuttle. Ottawa has demonstrated the capability to meet that requirement.

However, for your property to be considered applicable under our certification, it must be within 5km of a fire station and 2.5km of an approved water source.

*Allan Evans***Fire Protection Engineer / Ingénieur de Protection d'Incendies****Prevention Division / Prévention des Incendies****Ottawa Fire Services / Service des Incendies d'Ottawa**

1445 Carling Avenue / 1445 Avenue Carling

Ottawa, ON K1Z 7L9

Allan.Evans@Ottawa.ca

☎ (613) 913-2747 | ☎ (613) 580-2424 x24119 | 📠 (613) 580-2866 | ✉ Mail Code: 25-102 | @OFSFPE



OTTAWA FIRE SERVICES
SERVICE DES INCENDIES D'OTTAWA
*Protecting Our Nation's Capital With Pride
Protéger notre capitale nationale avec fierté*



An internationally accredited agency 2014-2019

From: EAU Services <eau.services.ottawa@gmail.com>

Sent: December 07, 2022 7:52 PM

To: Evans, Allan <Allan.Evans@ottawa.ca>

Subject: Re: FW: D07-12-19-0145 – 8520 McArton Road: Water Supply for Fire Protection as part of Site Plan Control

CAUTION: This email originated from an External Sender. Please do not click links or open attachments unless you recognize the source.

ATTENTION : Ce courriel provient d'un expéditeur externe. Ne cliquez sur aucun lien et n'ouvrez pas de pièce jointe, excepté si vous connaissez l'expéditeur.

Hi Allan,

Thanks for your email. Regarding 5 min that I am referring to, here is the link from Fire Underwriters Survey website:

[Superior Tanker Shuttle Service \(fireunderwriters.ca\)](http://fireunderwriters.ca)

Under Accredited Superior Shuttle Service, on paragraph 5, it reads:

- For commercial lines insurance, the fire department must be able to deliver a flow rate of not less than 1900 LPM (400 IGPM) within 5 minutes of arriving at the test site with the first major piece of apparatus (wheel stop).

Thanks,

On Wed, 7 Dec 2022 at 10:09, Evans, Allan <Allan.Evans@ottawa.ca> wrote:

We have superior tanker shuttle qualification – I will have to confirm that we meet the COMMERCIAL delivery portion.

Also, it's not "5 minutes", but 5km from a fire station and you have to be within 2.5km of an approved water source for it to meet FUS.

I'll confirm about the commercial part and get back to you.

2.5. Limitations

Recognition of Shuttle Service for fire insurance grading purposes is limited to the following road travel distances from the insured property:

- Commercial Lines (PFPC)
 - 5 km by road of first responding pumper AND mobile water supply apparatus; AND
 - 2.5 km by road of an approved water supply point
- Personal Lines (DPG)
 - 8 km by road of first responding pumper AND mobile water supply apparatus; AND
 - 5 km by road of an approved water supply point

Allan Evans

Fire Protection Engineer / Ingénieur de Protection d'Incendies

Prevention Division / Prévention des Incendies

Ottawa Fire Services / Service des Incendies d'Ottawa

1445 Carling Avenue / 1445 Avenue Carling

Ottawa, ON K1Z 7L9

Allan.Evans@Ottawa.ca

☎ (613) 913-2747 | ☎ (613) 580-2424 x24119 | ☎ (613) 580-2866 | ✉ Mail Code: 25-102 | @OFSFPE



OTTAWA FIRE SERVICES
SERVICE DES INCENDIES D'OTTAWA
*Protecting Our Nation's Capital With Pride
Protéger notre capitale nationale avec fierté*



An internationally accredited agency 2014-2019

From: EAU Services <eau.services.ottawa@gmail.com>

Sent: December 06, 2022 11:31 PM

To: Evans, Allan <Allan.Evans@ottawa.ca>

Subject: Re: FW: D07-12-19-0145 – 8520 McArton Road: Water Supply for Fire Protection as part of Site Plan Control

CAUTION: This email originated from an External Sender. Please do not click links or open attachments unless you recognize the source.

ATTENTION : Ce courriel provient d'un expéditeur externe. Ne cliquez sur aucun lien et n'ouvrez pas de pièce jointe, excepté si vous connaissez l'expéditeur.

Hi Allan,

Sorry to bother you again. I am wondering if you could confirm that Ottawa Fire Station 84 is accredited superior tank shuttle. Note this fire station is within 5 min of our development, 8520 McArton Road.

Based on FUS document, accredited superior tank shuttle shall be able to, theoretically, deliver 400 GPM in case of incident for commercial building. I understand that, in reality, it may not come as a guarantee due to multiple situational reasons, but, at least on paper and for the purpose of our

development approval, we need your confirmation.

Let me know if you have any questions.

Your help is much appreciated,

Bob

613-299-7689

On Mon, 28 Nov 2022 at 09:50, Evans, Allan <Allan.Evans@ottawa.ca> wrote:

Provided you meet the requirements of the FUS for fire station distance/water supply distance, then yes (sort of) as we are superior tanker shuttle qualified (note: residential and commercial have different distance criteria).

Our current methodology does not directly recognize this in terms of volume reduction (at least not directly). As we had previously agreed to 10000 gallons storage, it is worth discussing with building code services on whether they will accept this application "as is" for the 10000 gallons. If they will accept it, then you can move forward as-is. If they will not accept it, then the tanker shuttle could be a part of the engineering analysis proposal I mentioned below.

From your other email, no NFPA 1142 is not directly recognized by us (but can also be a part of the discussion).

Before moving forward more, I would recommend setting up a discussion with myself and Damien Whitaker on the volume storage and we can see what we need to do.

Allan Evans

Fire Protection Engineer / Ingénieur de Protection d'Incendies

Prevention Division / Prévention des Incendies

Ottawa Fire Services / Service des Incendies d'Ottawa

1445 Carling Avenue / 1445 Avenue Carling

Ottawa, ON K1Z 7L9

Allan.Evans@Ottawa.ca

☎ (613) 913-2747 | ☎ (613) 580-2424 x24119 | 📠 (613) 580-2866 | ✉ Mail Code: 25-102 | @OFSFPE



OTTAWA FIRE SERVICES
SERVICE DES INCENDIES D'OTTAWA
*Protecting Our Nation's Capital With Pride
Protéger notre capitale nationale avec fierté*



An internationally accredited agency 2014-2019

From: EAU Services <eau.services.ottawa@gmail.com>

Sent: November 25, 2022 2:55 PM

To: Evans, Allan <Allan.Evans@ottawa.ca>

Cc: Derrick Clark <derrick.r.clark@rogers.com>

Subject: Fwd: FW: D07-12-19-0145 – 8520 McArton Road: Water Supply for Fire Protection as part of Site Plan Control

CAUTION: This email originated from an External Sender. Please do not click links or open attachments unless you recognize the source.

ATTENTION : Ce courriel provient d'un expéditeur externe. Ne cliquez sur aucun lien et n'ouvrez pas de pièce jointe, excepté si vous connaissez l'expéditeur.

Hi Allan,

The fire demand calculation part of this project is for me to address. I normally follow the FUS calculation method for my projects. Generally, FUS do not allow less than 2000 LPM that would give about 440 IGPM. For a period of one hours, that would come up to 26000 Gallons.

I was reading the previous correspondents from you for this project and saw that you have given the green light for a 10,000 gallon water tank. I am wondering if the Fire department would be able to provide a certain amount of water supply that we can deduct from the calculations so that we end up with a smaller amount for the fire tank?

Thanks so much,

Bob

613-299-7689

----- Forwarded message -----

From: <juliette@wildbirdcarecentre.org>

Date: Wed, 23 Nov 2022 at 20:54

Subject: FW: D07-12-19-0145 – 8520 McArton Road: Water Supply for Fire Protection as part of Site Plan Control

To: EAU Services <eau.services.ottawa@gmail.com>

Cc: Derrick Clark <derrick.r.clark@rogers.com>

From: Evans, Allan <Allan.Evans@ottawa.ca>

Sent: September 26, 2022 2:20 PM

To: Husham Almansour <hkhha.adad@gmail.com>

Cc: Juliette Marczuk <juliette@wildbirdcarecentre.org>

Subject: RE: D07-12-19-0145 – 8520 McArton Road: Water Supply for Fire Protection as part of Site Plan Control

Hello – I am still okay with the 10000 gallon calculation. Please be advised that the new standard in the city is to either build to what the FUS calculates, or to have a proper analysis done by an outside qualified agency explaining why a reduced volume is acceptable – as this application has been progressing for such a long time, I'm of the opinion we can continue as originally proposed, but ultimately this will be up to building code services.

Two further points I see in the drawings:

First, the entryway should be a bit wider (8m minimum) where the fire truck will park. The truck itself is close to 3m wide, and the hard suction hose we connect between the truck and the hydrant is 3m long as well. With a 1.2m recess behind curb/bollards, this means the truck will stick out $3+(3-1.2m) = 4.8m$ (roughly – the port is partially recessed on the fire truck) in a 7m wide entryway. This leaves only 2.2m for the other fire trucks to get by which is not sufficient. An 8m wide entry would allow another truck to get by.

Also, the pipe connecting the storage tank to the hydrant should be a minimum 150mm (6").

I should also mention that if you are using a regular fire hydrant at the entrance, you should be careful to get the correct hydrant. If the water table is too high, you should get a hydrant with the weep holes sealed – this prevents water from coming up from outside and into the vertical pipe and freezing/damaging it in the winter. If the water

table is low enough, a regular hydrant should probably be okay but you should confirm with someone familiar with this type of installation. I don't believe a regular straight pipe with adapter would work as there would be water inside the pipe and subject to freezing.

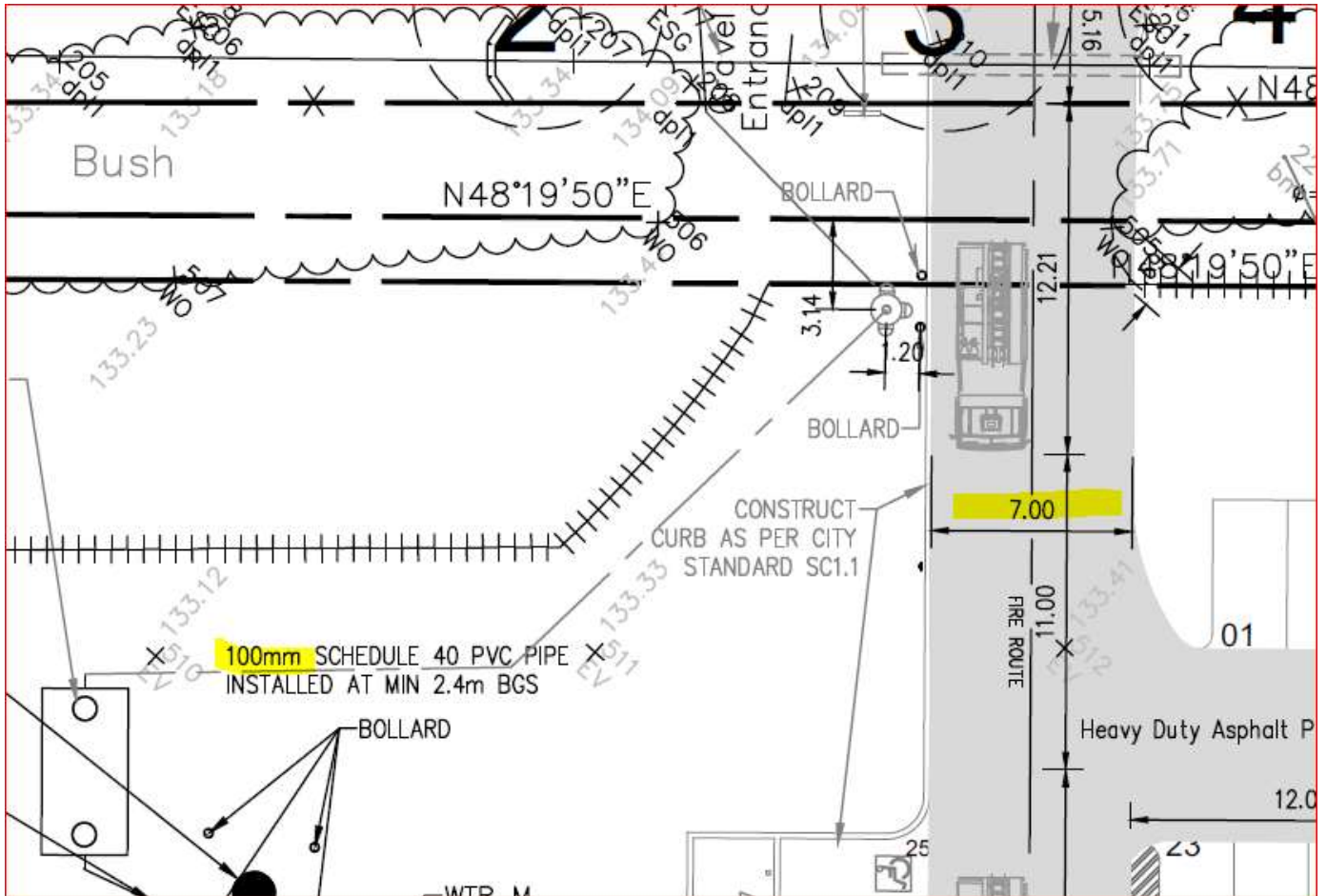

Allan Evans

Fire Protection Engineer / Ingénieur de Protection d'Incendies

Prevention Division / Prévention des Incendies

Ottawa Fire Services / Service des Incendies d'Ottawa

1445 Carling Avenue / 1445 Avenue Carling

Ottawa, ON K1Z 7L9

Allan.Evans@Ottawa.ca

☎ (613) 913-2747 | ☎ (613) 580-2424 x24119 | ☎ (613) 580-2866 | ✉ Mail Code: 25-102 | @OFSFPE



OTTAWA FIRE SERVICES
SERVICE DES INCENDIES D'OTTAWA
*Protecting Our Nation's Capital With Pride
Protéger notre capitale nationale avec fierté*



An internationally accredited agency 2014-2019

From: Husham Almansour <hkhha.adad@gmail.com>

Sent: September 26, 2022 8:27 AM

To: Evans, Allan <Allan.Evans@ottawa.ca>

Cc: Juliette Marczuk <juliette@wildbirdcarecentre.org>

Subject: D07-12-19-0145 – 8520 McArton Road: Water Supply for Fire Protection as part of Site Plan Control

CAUTION: This email originated from an External Sender. Please do not click links or open attachments unless you recognize the source.

ATTENTION : Ce courriel provient d'un expéditeur externe. Ne cliquez sur aucun lien et n'ouvrez pas de pièce jointe, excepté si vous connaissez l'expéditeur.

Good morning Allan,

I hope that you are doing well. I tried to reach you on the phone but unfortunately couldn't.

As part of the recent revision of the Site Plan Control Application 8520 McArton Road, We received the following comment.

“As of June of 2022, the new guideline ‘Water Supply for Public Fire Protection, 2020’ has come into effect (though dated 2020, the document only came out recently. It is not known why they backdated it). Please consult with Fire Services (Allan Evans) to determine if your application still meets the FUS directive replacing the former calculation/approach.”

Please advise if any adjustment of our calculation is required. I attached a copy of the report and Drawing SS-1 for your reference.

Best Regards,

Husham

Husham Almansour, P.Eng., Ph.D.

613 601 2139

This e-mail originates from the City of Ottawa e-mail system. Any distribution, use or copying of this e-mail or the information it contains by other than the intended recipient(s) is unauthorized. Thank you.

Le présent courriel a été expédié par le système de courriels de la Ville d'Ottawa. Toute distribution, utilisation ou reproduction du courriel ou des renseignements qui s'y trouvent par une personne autre que son destinataire prévu est interdite. Je vous remercie de votre collaboration.

This e-mail originates from the City of Ottawa e-mail system. Any distribution, use or copying of this e-mail or the information it contains by other than the intended recipient(s) is unauthorized. Thank you.

Le présent courriel a été expédié par le système de courriels de la Ville d'Ottawa. Toute distribution, utilisation ou reproduction du courriel ou des renseignements qui s'y trouvent par une personne autre que son destinataire prévu est interdite. Je vous remercie de votre collaboration.

This e-mail originates from the City of Ottawa e-mail system. Any distribution, use or copying of this e-mail or the information it contains by other than the intended recipient(s) is unauthorized. Thank you.

Le présent courriel a été expédié par le système de courriels de la Ville d'Ottawa. Toute distribution, utilisation ou reproduction du courriel ou des renseignements qui s'y trouvent par une personne autre que son destinataire prévu est interdite. Je vous remercie de votre collaboration.

This e-mail originates from the City of Ottawa e-mail system. Any distribution, use or copying of this e-mail or the information it contains by other than the intended recipient(s) is unauthorized. Thank you.

Le présent courriel a été expédié par le système de courriels de la Ville d'Ottawa. Toute distribution, utilisation ou reproduction du courriel ou des renseignements qui s'y trouvent par une personne autre que son destinataire prévu est interdite. Je vous remercie de votre collaboration.

RE: FW: D07-12-19-0145 – 8520 McArton Road: Water Supply for Fire Protection as part of Site Plan Control

1 message

Evans, Allan <Allan.Evans@ottawa.ca>
To: EAU Services <eau.services.ottawa@gmail.com>

9 December 2022 at 09:08

Yes – that is within arriving on scene (how fast we can setup and flow water). That is a part of becoming certified under FUS for superior tanker shuttle. Ottawa has demonstrated the capability to meet that requirement.

However, for your property to be considered applicable under our certification, it must be within 5km of a fire station and 2.5km of an approved water source.

Allan Evans

Fire Protection Engineer / Ingénieur de Protection d'Incendies

Prevention Division / Prévention des Incendies

Ottawa Fire Services / Service des Incendies d'Ottawa

[1445 Carling Avenue](#) / 1445 Avenue Carling

Ottawa, ON K1Z 7L9

Allan.Evans@Ottawa.ca

☎ (613) 913-2747 | 📠 (613) 580-2424 x24119 | 📠 (613) 580-2866 | 📧 Mail Code: 25-102 | @OFSFPE



OTTAWA FIRE SERVICES
SERVICE DES INCENDIES D'OTTAWA
*Protecting Our Nation's Capital With Pride
Protéger notre capitale nationale avec fierté*



An internationally accredited agency 2014-2019

From: EAU Services <eau.services.ottawa@gmail.com>**Sent:** December 07, 2022 7:52 PM**To:** Evans, Allan <Allan.Evans@ottawa.ca>**Subject:** Re: FW: D07-12-19-0145 – 8520 McArton Road: Water Supply for Fire Protection as part of Site Plan Control

CAUTION: This email originated from an External Sender. Please do not click links or open attachments unless you recognize the source.

ATTENTION : Ce courriel provient d'un expéditeur externe. Ne cliquez sur aucun lien et n'ouvrez pas de pièce jointe, excepté si vous connaissez l'expéditeur.

Hi Allan,

Thanks for your email. Regarding 5 min that I am referring to, here is the link from Fire Underwriters Survey website:

[Superior Tanker Shuttle Service \(fireunderwriters.ca\)](http://fireunderwriters.ca)

Under Accredited Superior Shuttle Service, on paragraph 5, it reads:

- For commercial lines insurance, the fire department must be able to deliver a flow rate of not less than 1900 LPM (400 IGPM) within 5 minutes of arriving at the test site with the first major piece of apparatus (wheel stop).

Thanks,

On Wed, 7 Dec 2022 at 10:09, Evans, Allan <Allan.Evans@ottawa.ca> wrote:

We have superior tanker shuttle qualification – I will have to confirm that we meet the COMMERCIAL delivery portion.

Also, it's not "5 minutes", but 5km from a fire station and you have to be within 2.5km of an approved water source for it to meet FUS.

I'll confirm about the commercial part and get back to you.

2.5. Limitations

Recognition of Shuttle Service for fire insurance grading purposes is limited to the following road travel distances from the insured property:

- Commercial Lines (PFPC)
 - 5 km by road of first responding pumper AND mobile water supply apparatus; AND
 - 2.5 km by road of an approved water supply point
- Personal Lines (DPG)
 - 8 km by road of first responding pumper AND mobile water supply apparatus; AND
 - 5 km by road of an approved water supply point

Allan Evans

Fire Protection Engineer / Ingénieur de Protection d'Incendies

Prevention Division / Prévention des Incendies

Ottawa Fire Services / Service des Incendies d'Ottawa

1445 Carling Avenue / 1445 Avenue Carling

Ottawa, ON K1Z 7L9

Allan.Evans@Ottawa.ca



OTTAWA FIRE SERVICES
SERVICE DES INCENDIES D'OTTAWA
*Protecting Our Nation's Capital With Pride
Protéger notre capitale nationale avec fierté*



An internationally accredited agency 2014-2019

From: EAU Services <eau.services.ottawa@gmail.com>

Sent: December 06, 2022 11:31 PM

To: Evans, Allan <Allan.Evans@ottawa.ca>

Subject: Re: FW: D07-12-19-0145 – 8520 McArton Road: Water Supply for Fire Protection as part of Site Plan Control

CAUTION: This email originated from an External Sender. Please do not click links or open attachments unless you recognize the source.

ATTENTION : Ce courriel provient d'un expéditeur externe. Ne cliquez sur aucun lien et n'ouvrez pas de pièce jointe, excepté si vous connaissez l'expéditeur.

Hi Allan,

Sorry to bother you again. I am wondering if you could confirm that Ottawa Fire Station 84 is accredited superior tank shuttle. Note this fire station is within 5 min of our development, 8520 McArton Road.

Based on FUS document, accredited superior tank shuttle shall be able to, theoretically, deliver 400 GPM in case of incident for commercial building. I understand that, in reality, it may not come as a guarantee due to multiple situational reasons, but, at least on paper and for the purpose of our development approval, we need your confirmation.

Let me know if you have any questions.

Your help is much appreciated,

Bob

613-299-7689

On Mon, 28 Nov 2022 at 09:50, Evans, Allan <Allan.Evans@ottawa.ca> wrote:

Provided you meet the requirements of the FUS for fire station distance/water supply distance, then yes (sort of) as we are superior tanker shuttle qualified (note: residential and commercial have different distance criteria).

Our current methodology does not directly recognize this in terms of volume reduction (at least not directly). As we had previously agreed to 10000 gallons storage, it is worth discussing with building code services on whether they will accept this application "as is" for the 10000 gallons. If they will accept it, then you can move forward as-is. If they will not accept it, then the tanker shuttle could be a part of the engineering analysis proposal I mentioned below.

From your other email, no NFPA 1142 is not directly recognized by us (but can also be a part of the discussion).

Before moving forward more, I would recommend setting up a discussion with myself and Damien Whitaker on the volume storage and we can see what we need to do.

Allan Evans

Fire Protection Engineer / Ingénieur de Protection d'Incendies

Prevention Division / Prévention des Incendies

Ottawa Fire Services / Service des Incendies d'Ottawa

1445 Carling Avenue / 1445 Avenue Carling

Ottawa, ON K1Z 7L9

Allan.Evans@Ottawa.ca

☎ (613) 913-2747 | ☎ (613) 580-2424 x24119 | 📠 (613) 580-2866 | 📧 Mail Code: 25-102 | @OFSFPE



OTTAWA FIRE SERVICES
SERVICE DES INCENDIES D'OTTAWA
*Protecting Our Nation's Capital With Pride
Protéger notre capitale nationale avec fierté*



An internationally accredited agency 2014-2019

From: EAU Services <eau.services.ottawa@gmail.com>

Sent: November 25, 2022 2:55 PM

To: Evans, Allan <Allan.Evans@ottawa.ca>

Cc: Derrick Clark <derrick.r.clark@rogers.com>

Subject: Fwd: FW: D07-12-19-0145 – 8520 McArton Road: Water Supply for Fire Protection as part of Site Plan Control

CAUTION: This email originated from an External Sender. Please do not click links or open attachments unless you recognize the source.

ATTENTION : Ce courriel provient d'un expéditeur externe. Ne cliquez sur aucun lien et n'ouvrez pas de pièce jointe, excepté si vous connaissez l'expéditeur.

Hi Allan,

The fire demand calculation part of this project is for me to address. I normally follow the FUS calculation method for my projects. Generally, FUS do not allow less than 2000 LPM that would give about 440 IGPM. For a period of one hours, that would come up to 26000 Gallons.

I was reading the previous correspondents from you for this project and saw that you have given the green light for a 10,000 gallon water tank. I am wondering if the Fire department would be able to provide a certain amount of water supply that we can deduct from the calculations so that we end up with a smaller amount for the fire tank?

Thanks so much,

Bob

613-299-7689

----- Forwarded message -----

From: <juliette@wildbirdcarecentre.org>

Date: Wed, 23 Nov 2022 at 20:54

Subject: FW: D07-12-19-0145 – 8520 McArton Road: Water Supply for Fire Protection as part of Site Plan Control

To: EAU Services <eau.services.ottawa@gmail.com>

Cc: Derrick Clark <derrick.r.clark@rogers.com>

From: Evans, Allan <Allan.Evans@ottawa.ca>

Sent: September 26, 2022 2:20 PM

To: Husham Almansour <hkhha.adad@gmail.com>

Cc: Juliette Marczuk <juliette@wildbirdcarecentre.org>

Subject: RE: D07-12-19-0145 – 8520 McArton Road: Water Supply for Fire Protection as part of Site Plan Control

Hello – I am still okay with the 10000 gallon calculation. Please be advised that the new standard in the city is to either build to what the FUS calculates, or to have a proper analysis done by an outside qualified agency explaining why a reduced volume is acceptable – as this application has been progressing for such a long time, I'm of the opinion we can continue as originally proposed, but ultimately this will be up to building code services.

Two further points I see in the drawings:

First, the entryway should be a bit wider (8m minimum) where the fire truck will park. The truck itself is close to 3m wide, and the hard suction hose we connect between the truck and the hydrant is 3m long as well. With a 1.2m recess behind curb/bollards, this means the truck will stick out $3+(3-1.2m) = 4.8m$ (roughly – the port is partially recessed on the fire truck) in a 7m wide entryway. This leaves only 2.2m for the other fire trucks to get by which is not sufficient. An 8m wide entry would allow another truck to get by.

Also, the pipe connecting the storage tank to the hydrant should be a minimum 150mm (6").

I should also mention that if you are using a regular fire hydrant at the entrance, you should be careful to get the correct hydrant. If the water table is too high, you should get a hydrant with the weep holes sealed – this prevents water from coming up from outside and into the vertical pipe and freezing/damaging it in the winter. If the water table is low enough, a regular hydrant should probably be okay but you should confirm with someone familiar with this type of installation. I don't believe a regular straight pipe with adapter would work as there would be water inside the pipe and subject to freezing.

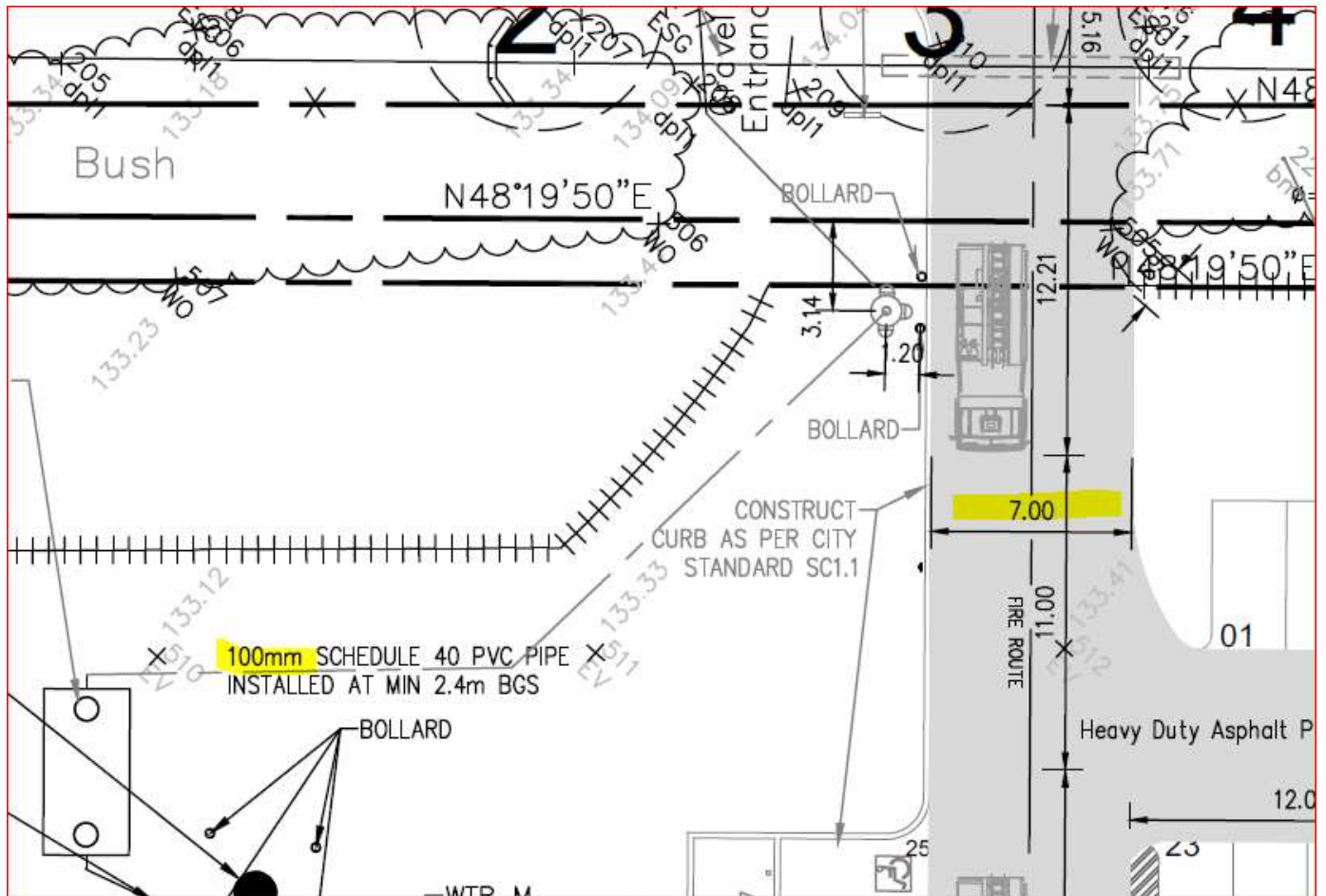

Allan Evans

Fire Protection Engineer / Ingénieur de Protection d'Incendies

Prevention Division / Prévention des Incendies

Ottawa Fire Services / Service des Incendies d'Ottawa

1445 Carling Avenue / 1445 Avenue Carling

Ottawa, ON K1Z 7L9

Allan.Evans@Ottawa.ca

☎ (613) 913-2747 | ☎ (613) 580-2424 x24119 | 📠 (613) 580-2866 | ✉ Mail Code: 25-102 | @OFSFPE



OTTAWA FIRE SERVICES
SERVICE DES INCENDIES D'OTTAWA
*Protecting Our Nation's Capital With Pride
Protéger notre capitale nationale avec fierté*



An internationally accredited agency 2014-2019

From: Husham Almansour <hkhha.adad@gmail.com>

Sent: September 26, 2022 8:27 AM

To: Evans, Allan <Allan.Evans@ottawa.ca>

Cc: Juliette Marczuk <juliette@wildbirdcarecentre.org>

Subject: D07-12-19-0145 – 8520 McArton Road: Water Supply for Fire Protection as part of Site Plan Control

CAUTION: This email originated from an External Sender. Please do not click links or open attachments unless you recognize the source.

ATTENTION : Ce courriel provient d'un expéditeur externe. Ne cliquez sur aucun lien et n'ouvrez pas de pièce jointe, excepté si vous connaissez l'expéditeur.

Good morning Allan,

I hope that you are doing well. I tried to reach you on the phone but unfortunately couldn't.

As part of the recent revision of the Site Plan Control Application 8520 McArton Road, We received the following comment.

"As of June of 2022, the new guideline 'Water Supply for Public Fire Protection, 2020' has come into effect (though dated 2020, the document only came out recently. It is not known why they backdated it). Please consult with Fire Services (Allan Evans) to determine if you application still meets the FUS directive replacing the former calculation/approach."

Please advise if any adjustment of our calculation is required. I attached a copy of the report and Drawing SS-1 for your reference.

Best Regards,

Husham

Husham Almansour, P.Eng., Ph.D.

613 601 2139

This e-mail originates from the City of Ottawa e-mail system. Any distribution, use or copying of this e-mail or the information it contains by other than the intended recipient(s) is unauthorized. Thank you.

Le présent courriel a été expédié par le système de courriels de la Ville d'Ottawa. Toute distribution, utilisation ou reproduction du courriel ou des renseignements qui s'y trouvent par une personne autre que son destinataire prévu est interdite. Je vous remercie de votre collaboration.

This e-mail originates from the City of Ottawa e-mail system. Any distribution, use or copying of this e-mail or the information it contains by other than the intended recipient(s) is unauthorized. Thank you.

Le présent courriel a été expédié par le système de courriels de la Ville d'Ottawa. Toute distribution, utilisation ou reproduction du courriel ou des renseignements qui s'y trouvent par une personne autre que son destinataire prévu est interdite. Je vous remercie de votre collaboration.

This e-mail originates from the City of Ottawa e-mail system. Any distribution, use or copying of this e-mail or the information it contains by other than the intended recipient(s) is unauthorized. Thank you.

Le présent courriel a été expédié par le système de courriels de la Ville d'Ottawa. Toute distribution, utilisation ou reproduction du courriel ou des renseignements qui s'y trouvent par une personne autre que son destinataire prévu est interdite. Je vous remercie de votre collaboration.

This e-mail originates from the City of Ottawa e-mail system. Any distribution, use or copying of this e-mail or the information it contains by other than the intended recipient(s) is unauthorized. Thank you.

Le présent courriel a été expédié par le système de courriels de la Ville d'Ottawa. Toute distribution, utilisation ou reproduction du courriel ou des renseignements qui s'y trouvent par une personne autre que son destinataire prévu est interdite. Je vous remercie de votre collaboration.

RE: FW: D07-12-19-0145 – 8520 McArton Road: Water Supply for Fire Protection as part of Site Plan Control

1 message

Evans, Allan <Allan.Evans@ottawa.ca>
To: EAU Services <eau.services.ottawa@gmail.com>

7 December 2022 at 10:08

We have superior tanker shuttle qualification – I will have to confirm that we meet the COMMERCIAL delivery portion.

Also, it's not "5 minutes", but 5km from a fire station and you have to be within 2.5km of an approved water source for it to meet FUS.

I'll confirm about the commercial part and get back to you.

2.5. Limitations

Recognition of Shuttle Service for fire insurance grading purposes is limited to the following road travel distances from the insured property:

- Commercial Lines (PFPC)
 - 5 km by road of first responding pumper AND mobile water supply apparatus; AND
 - 2.5 km by road of an approved water supply point
- Personal Lines (DPG)
 - 8 km by road of first responding pumper AND mobile water supply apparatus; AND
 - 5 km by road of an approved water supply point

*Allan Evans***Fire Protection Engineer / Ingénieur de Protection d'Incendies****Prevention Division / Prévention des Incendies****Ottawa Fire Services / Service des Incendies d'Ottawa****1445 Carling Avenue / 1445 Avenue Carling****Ottawa, ON K1Z 7L9****Allan.Evans@Ottawa.ca****☎ (613) 913-2747 | ☎ (613) 580-2424 x24119 | 📠 (613) 580-2866 | ✉ Mail Code: 25-102 | @OFSFPE**



From: EAU Services <eau.services.ottawa@gmail.com>
Sent: December 06, 2022 11:31 PM
To: Evans, Allan <Allan.Evans@ottawa.ca>
Subject: Re: FW: D07-12-19-0145 – 8520 McArton Road: Water Supply for Fire Protection as part of Site Plan Control

CAUTION: This email originated from an External Sender. Please do not click links or open attachments unless you recognize the source.

ATTENTION : Ce courriel provient d'un expéditeur externe. Ne cliquez sur aucun lien et n'ouvrez pas de pièce jointe, excepté si vous connaissez l'expéditeur.

Hi Allan,

Sorry to bother you again. I am wondering if you could confirm that Ottawa Fire Station 84 is accredited superior tank shuttle. Note this fire station is within 5 min of our development, 8520 McArton Road.

Based on FUS document, accredited superior tank shuttle shall be able to, theoretically, deliver 400 GPM in case of incident for commercial building. I understand that, in reality, it may not come as a guarantee due to multiple situational reasons, but, at least on paper and for the purpose of our development approval, we need your confirmation.

Let me know if you have any questions.

Your help is much appreciated,

Bob

613-299-7689

On Mon, 28 Nov 2022 at 09:50, Evans, Allan <Allan.Evans@ottawa.ca> wrote:

Provided you meet the requirements of the FUS for fire station distance/water supply distance, then yes (sort of) as we are superior tanker shuttle qualified (note: residential and commercial have different distance criteria).

Our current methodology does not directly recognize this in terms of volume reduction (at least not directly). As we had previously agreed to 10000 gallons storage, it is worth discussing with building code services on whether they will accept this application "as is" for the 10000 gallons. If they will accept it, then you can move forward as-is. If they will not accept it, then the tanker shuttle could be a part of the engineering analysis proposal I mentioned below.

From your other email, no NFPA 1142 is not directly recognized by us (but can also be a part of the discussion).

Before moving forward more, I would recommend setting up a discussion with myself and Damien Whitaker on the volume storage and we can see what we need to do.

Allan Evans

Fire Protection Engineer / Ingénieur de Protection d'Incendies

Prevention Division / Prévention des Incendies

Ottawa Fire Services / Service des Incendies d'Ottawa

1445 Carling Avenue / 1445 Avenue Carling

Ottawa, ON K1Z 7L9

Allan.Evans@Ottawa.ca

☎ (613) 913-2747 | ☎ (613) 580-2424 x24119 | 📠 (613) 580-2866 | ✉ Mail Code: 25-102 | @OFSFPE



OTTAWA FIRE SERVICES
SERVICE DES INCENDIES D'OTTAWA

*Protecting Our Nation's Capital With Pride
Protéger notre capitale nationale avec fierté*



An internationally accredited agency 2014-2019

From: EAU Services <eau.services.ottawa@gmail.com>

Sent: November 25, 2022 2:55 PM

To: Evans, Allan <Allan.Evans@ottawa.ca>

Cc: Derrick Clark <derrick.r.clark@rogers.com>

Subject: Fwd: FW: D07-12-19-0145 – 8520 McArton Road: Water Supply for Fire Protection as part of Site Plan Control

CAUTION: This email originated from an External Sender. Please do not click links or open attachments unless you recognize the source.

ATTENTION : Ce courriel provient d'un expéditeur externe. Ne cliquez sur aucun lien et n'ouvrez pas de pièce jointe, excepté si vous connaissez l'expéditeur.

Hi Allan,

The fire demand calculation part of this project is for me to address. I normally follow the FUS calculation method for my projects. Generally, FUS do not allow less than 2000 LPM that would give about 440 IGPM. For a period of one hours, that would come up to 26000 Gallons.

I was reading the previous correspondents from you for this project and saw that you have given the green light for a 10,000 gallon water tank. I am wondering if the Fire department would be able to provide a certain amount of water supply that we can deduct from the calculations so that we end up with a smaller amount for the fire tank?

Thanks so much,

Bob

613-299-7689

----- Forwarded message -----

From: <juliette@wildbirdcarecentre.org>

Date: Wed, 23 Nov 2022 at 20:54

Subject: FW: D07-12-19-0145 – 8520 McArton Road: Water Supply for Fire Protection as part of Site Plan Control

To: EAU Services <eau.services.ottawa@gmail.com>

Cc: Derrick Clark <derrick.r.clark@rogers.com>

From: Evans, Allan <Allan.Evans@ottawa.ca>

Sent: September 26, 2022 2:20 PM

To: Husham Almansour <hkhha.adad@gmail.com>

Cc: Juliette Marczuk <juliette@wildbirdcarecentre.org>

Subject: RE: D07-12-19-0145 – 8520 McArton Road: Water Supply for Fire Protection as part of Site Plan Control

Hello – I am still okay with the 10000 gallon calculation. Please be advised that the new standard in the city is to either build to what the FUS calculates, or to have a proper analysis done by an outside qualified agency explaining why a reduced volume is acceptable – as this application has been progressing for such a long time, I'm of the opinion we can continue as originally proposed, but ultimately this will be up to building code services.

Two further points I see in the drawings:

First, the entryway should be a bit wider (8m minimum) where the fire truck will park. The truck itself is close to 3m wide, and the hard suction hose we connect between the truck and the hydrant is 3m long as well. With a 1.2m recess behind curb/bollards, this means the truck will stick out $3+(3-1.2m) = 4.8m$ (roughly – the port is partially recessed on the fire truck) in a 7m wide entryway. This leaves only 2.2m for the other fire trucks to get by which is not sufficient. An 8m wide entry would allow another truck to get by.

Also, the pipe connecting the storage tank to the hydrant should be a minimum 150mm (6").

I should also mention that if you are using a regular fire hydrant at the entrance, you should be careful to get the correct hydrant. If the water table is too high, you should get a hydrant with the weep holes sealed – this prevents water from coming up from outside and into the vertical pipe and freezing/damaging it in the winter. If the water table is low enough, a regular hydrant should probably be okay but you should confirm with someone familiar with this type of installation. I don't believe a regular straight pipe with adapter would work as there would be water inside the pipe and subject to freezing.

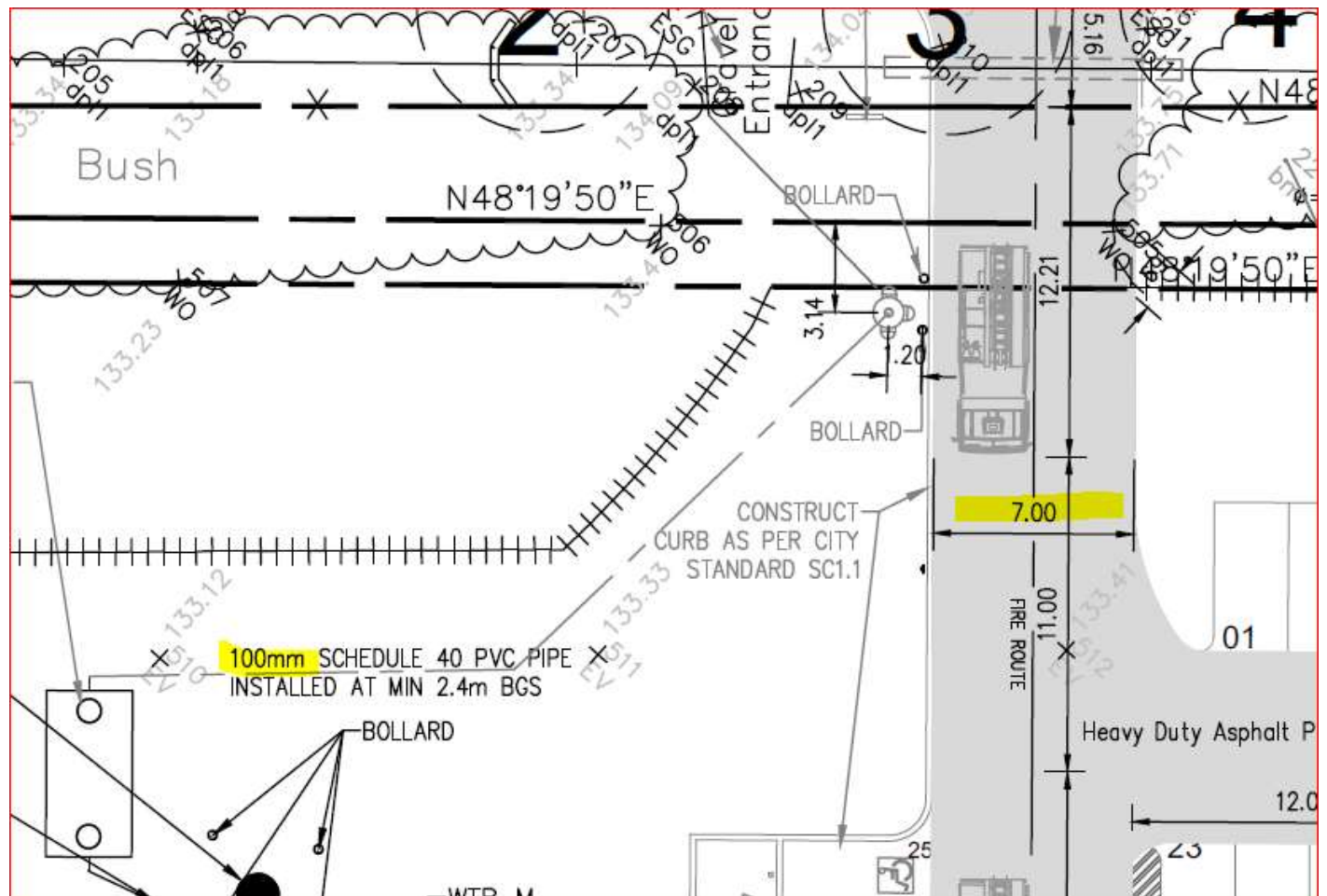

Allan Evans

Fire Protection Engineer / Ingénieur de Protection d'Incendies

Prevention Division / Prévention des Incendies

Ottawa Fire Services / Service des Incendies d'Ottawa

[1445 Carling Avenue](#) / 1445 Avenue Carling

Ottawa, ON K1Z 7L9

Allan.Evans@Ottawa.ca

☎ (613) 913-2747 | ☎ (613) 580-2424 x24119 | 📠 (613) 580-2866 | ✉ Mail Code: 25-102 | @OFSFPE



OTTAWA FIRE SERVICES
SERVICE DES INCENDIES D'OTTAWA
Protecting Our Nation's Capital With Pride
Protéger notre capitale nationale avec fierté



An internationally accredited agency 2014-2019

From: Husham Almansour <hkhha.adad@gmail.com>

Sent: September 26, 2022 8:27 AM

To: Evans, Allan <Allan.Evans@ottawa.ca>

Cc: Juliette Marczuk <juliette@wildbirdcarecentre.org>

Subject: D07-12-19-0145 – 8520 McArton Road: Water Supply for Fire Protection as part of Site Plan Control

Good morning Allan,

CAUTION: This email originated from an External Sender. Please do not click links or open attachments unless you recognize the source.

ATTENTION : Ce courriel provient d'un expéditeur externe. Ne cliquez sur aucun lien et n'ouvrez pas de pièce jointe, excepté si vous connaissez l'expéditeur.

I hope that you are doing well. I tried to reach you on the phone but unfortunately couldn't.

As part of the recent revision of the Site Plan Control Application 8520 McArton Road, We received the following comment.

"As of June of 2022, the new guideline 'Water Supply for Public Fire Protection, 2020' has come into effect (though dated 2020, the document only came out recently. It is not known why they backdated it). Please consult with Fire Services (Allan Evans) to determine if your application still meets the FUS directive replacing the former calculation/approach."

Please advise if any adjustment of our calculation is required. I attached a copy of the report and Drawing SS-1 for your reference.

Best Regards,

Husham

Husham Almansour, P.Eng., Ph.D.

613 601 2139

This e-mail originates from the City of Ottawa e-mail system. Any distribution, use or copying of this e-mail or the information it contains by other than the intended recipient(s) is unauthorized. Thank you.

Le présent courriel a été expédié par le système de courriels de la Ville d'Ottawa. Toute distribution, utilisation ou reproduction du courriel ou des renseignements qui s'y trouvent par une personne autre que son destinataire prévu est interdite. Je vous remercie de votre collaboration.

This e-mail originates from the City of Ottawa e-mail system. Any distribution, use or copying of this e-mail or the information it contains by other than the intended recipient(s) is unauthorized. Thank you.

Le présent courriel a été expédié par le système de courriels de la Ville d'Ottawa. Toute distribution, utilisation ou reproduction du courriel ou des renseignements qui s'y trouvent par une personne autre que son destinataire prévu est interdite. Je vous remercie de votre collaboration.

This e-mail originates from the City of Ottawa e-mail system. Any distribution, use or copying of this e-mail or the information it contains by other than the intended recipient(s) is unauthorized. Thank you.

Le présent courriel a été expédié par le système de courriels de la Ville d'Ottawa. Toute distribution, utilisation ou reproduction du courriel ou des renseignements qui s'y trouvent par une personne autre que son destinataire prévu est interdite. Je vous remercie de votre collaboration.