

# PROPOSED ANIMAL HOSPITAL/ OTTAWA VALLEY WILD BIRD CARE CENTRE



## SITE SERVICING AND STORMWATER MANAGEMENT REPORT for 8520 MCARTON ROAD, OTTAWA, ONTARIO

**MARCH 23, 2022/  
Reviewed MARCH 19, 2023**

Advanced Design, Assessment & Development Inc  
Authored by: Husham ALMANSOUR, Ph.D., P.Eng.





# **SITE SERVICING AND STORMWATER MANAGEMENT REPORT**

**for**

**8520 MCARTON ROAD,  
OTTAWA, ONTARIO**

**Prepared BY**

**ADAD Inc.**

**SUBMITTED TO:**

Juliette Marczuk  
Chair, Board of Directors  
Ottawa Valley Wild Bird Care Centre  
C: (613) 291-1137

**Report No.: 1912-01-R1**

**Issued on: March 23, 2022**

**Revision (6): July 12, 2022**

**Revision (7): March 19, 2022**



## TABLE OF CONTENTS

TABLE OF CONTENTS .....	1
LIST OF FIGURES .....	3
LIST OF TABLES .....	3
1. INTRODUCTION .....	5
1.1 General:.....	5
1.2 Report Structure: .....	5
1.3 References: .....	6
2. SITE SERVICES.....	8
2.1 General.....	8
2.1.1 Current Site Condition.....	8
2.1.2 Proposed Site .....	8
2.2 Water Supply and Well Water Quality .....	8
2.3 Fire Protection .....	9
2.4 Sanitary Servicing.....	9
2.4.1 Sanitary Servicing for the Building .....	9
2.4.2 Servicing for Outdoor Aviaries .....	10
3. STORMWATER MANAGEMENT .....	12
3.1 Design Criterion.....	12
3.2 Pre-Development Release Rate .....	13
3.3 Calculation of Allowable Release Rate.....	14
3.4 Calculation of Post-Development Release Rate.....	16
3.5 Storage Requirements.....	18
3.6 ICD/ Orifice Design.....	19
3.7 Proposed Stormwater Management Plan.....	19
3.7.1 Proposed Runoff Flow Quantity Controls .....	19
3.7.2 Proposed Quality Controls .....	20
4. EROSION AND SEDIMENT CONTROL.....	21
5. Summary & Conclusions.....	22
6. Appendix A: Details of a Precast Concrete Fire Protection Tank .....	25
7. Appendix B: StormWater Management Design Sheets/ Tables.....	27

8. Appendix C: Stormceptor sizing, maintenance, and Technical Manual- Canada..... 35

## LIST OF FIGURES

Figure 1-1 – Site Location.....	7
Figure 6-1 – Details of a Precast Concrete Fire Protection Tank with a 40,000 L Capacity .....	26

## LIST OF TABLES

Table 3-1 – Summary of Post-Development Flows Compared to Pre-Development Flows .....	18
Table 3-2 – Summary of Flows Runoff increase due to Post-Development.....	18
Table 7-1 – Calculations of Average Runoff Coefficients (Pre-Development) .....	28
Table 7-2 – Calculations of Peak Runoff (Pre-Development) .....	28
Table 7-3 – Calculations of Allowable Runoff (Pre-Development) .....	29
Table 7-4 – Calculations of Average Runoff Coefficients (Post-Development).....	29
Table 7-5 – Calculations of Peak Runoff (Post-Development).....	30
Table 7-6 – Calculations of Post-Development increase in Runoff Rate Based on Allowable Runoff.....	31
Table 7-7 – Storage Volumes for 5-year and 100-year Return Period Storms (Modified Rational Method) for watershed EWS-02 .....	32
Table 7-8 – Storage Volumes for 5-year and 100-year Return Period Storms (Modified Rational Method) for overall watershed EWS-03B .....	33
Table 7-9 – Detailed Calculations for the Design of ICDs for EWS-2 .....	34
Table 7-10 – Detailed Calculations for the Design of ICDs for EWS-3B.....	34





## **1. INTRODUCTION**

### **1.1 General:**

The following report demonstrates, in brief, the site plan servicing and the stormwater management in support of a Site Plan Application for 8520 McArton Road, City of Ottawa, Ontario. Out of 7 hectares of the total area of the land, the 0.863-hectare development being proposed will potentially be the new location for the Ottawa Valley Wild Bird Care Centre. The development includes an animal hospital with a rehabilitation centre, parking area, and all required services. Figure 1 shows summer and winter aerial views of the property.

The principal concept in the site plan servicing and stormwater management is to integrate the site with the surrounding environment in a sustainable yet cost-effective approach. The report covers a brief explanation of each service, detailed calculations in compliance with the City of Ottawa and provincial requirements and by-laws for submission with the engineering drawings for City of Ottawa site plan approval.

### **1.2 Report Structure:**

The City of Ottawa and the Ontario Ministry of the Environment Guidelines were used where applicable.

This report is divided into four sections:

- i. Introduction.
- ii. Site Service: includes current site condition, proposed site, fire protection, and sanitary servicing.
- iii. Stormwater Management: includes design criterion, pre-development release rate, calculation of allowable release rate, calculation of post-development release rate, storage requirements, and proposed stormwater management plan.
- iv. Erosion and Sediment Control.
- v. Summary and Conclusions.
- vi. Three Appendices:
  - Appendix A: Details of a Precast Concrete Fire Protection Tank
  - Appendix B: Stormwater Management Design Sheets/ Tables.
  - Appendix C: Stormceptor Sizing and Maintenance Report.

### 1.3 References:

Various documents were referred to in preparing the current report, including:

- Ottawa Sewer Design Guidelines, City of Ottawa, SDG002, October 2012.
- Tech Bulletin ISTB-2018-02, Revision to Ottawa Design Guidelines – Water Distribution.
- Ontario Building Code, Ontario, <https://www.ontario.ca/laws/regulation/120332>
- Stormwater Management Planning and Design Manual, Ontario Ministry of the Environment (MOE), 2003.



Summer view

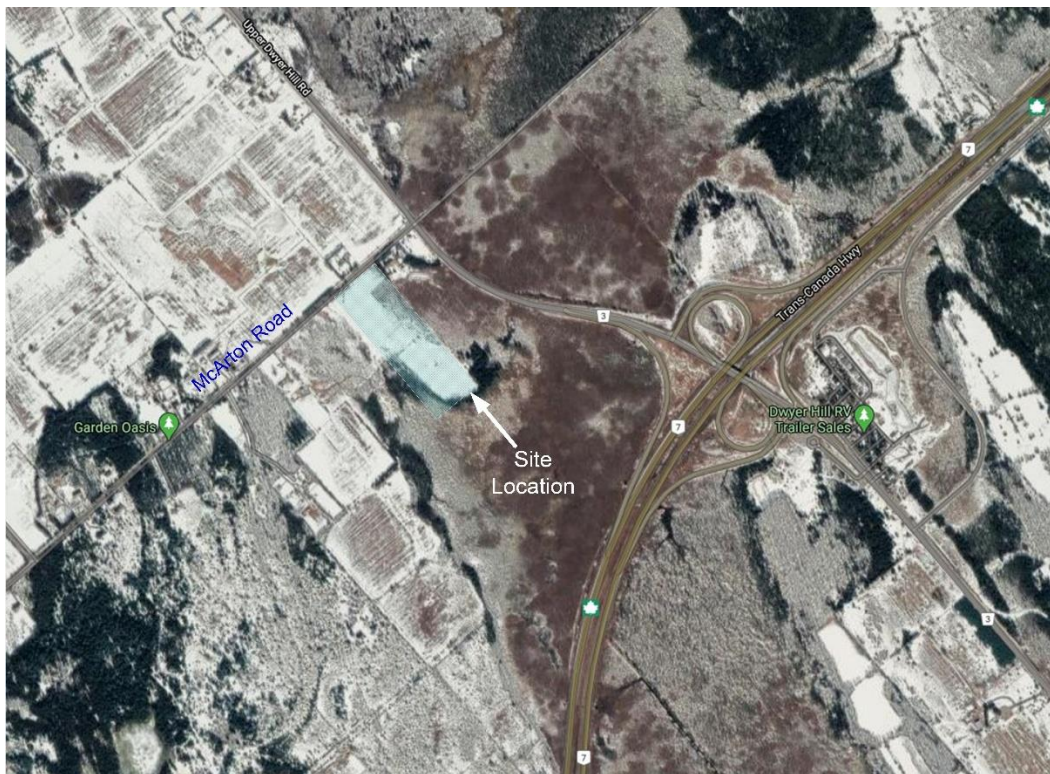

Winter View

**Figure 1-1 – Site Location**

## 2. SITE SERVICES

### 2.1 General

#### 2.1.1 Current Site Condition

The property has an approximate surface area of 7 ha (17 acres) located at 8520 Mcarton Road in Ottawa, Ontario. The site is currently vacant and covered by tall grasses and shrubs, with trees on the western and southern extent of the site. The land has an irregular rectangular shape, about 191m wide (east-west) by 365 deep (north-south). The site is mostly flat. The overall site drainage goes to the east towards the existing wetlands, with some low-lying areas lacking surficial drainage due to the topography of the site. The average site slope is approximately 3% from an elevation of  $+133.47 \pm 0.15$  meters above sea level (masl) to  $+131.82 \pm 0.15$  masl.

#### 2.1.2 Proposed Site

It is proposed to construct an institutional building that will serve as an animal/bird hospital for local wildlife with offices and an educational centre. Besides, the site will contain a parking area for employees and clients. The footprint of the building will be  $623.25 \text{ m}^2$  with an additional  $312.4 \text{ m}^2$  outdoor fly zone near the building on the south and west sides. There will be one entrance to access the site from McArton road. A total of 24 parking spots are required as well as a fire route running from McArton Road beside the east side of the building. The site will be serviced by a private well and a conventional septic system. Referring to the approved hydrogeological report (dated September 18, 2019) regarding the (30 m) required distance between the well and the septic system; drawing SS-1 shows:

- i. The distance between the well and the septic bed downgradient is 66.14 m;
- ii. The distance between the well and the septic tank of the building is 33.6 m.
- iii. The distance between the well and the septic tank of the Birds Aviaries is 56.2.

### 2.2 Water Supply and Well Water Quality

There is no municipal water available in this area of the City. The site will be serviced with water using a private well on site. The approximate location of the well was chosen on the northwest of the building (see drawing SS-1) based on the recommendations of the hydrogeological study prepared by Geofirma Engineering Ltd, dated September 18, 2018. Detailed information and hydraulic data, and water quality are provided by Geofirma Engineering Ltd. final report titled "Hydrogeological Study/ 8520 McArton Road, Ottawa, Ontario", on April 30, 2020. As related to the water quality, the report shows a comparison of the water quality results to aesthetic, analytical and indicator parameters outlined in Procedure D-5-5, and the ODWS indicates the following:

- Hardness, reported at 283 mg/L and 290 mg/L, is above the operation guideline (OG) range of 80-100 mg/L. The ODWS states that hardness values greater than 200 mg/L,

but less than 500 mg/L, are considered poor but tolerable. Hardness is easily treated with standard water softener systems.

- Iron, reported at 0.4 mg/L for both samples, is just above the aesthetic objective (AO) of 0.3 mg/L. Iron concentrations up to 5 mg/L are easily treated with a water softener or manganese green-sand filter.
- Laboratory reported colour was 12 and 20 TCU for the 3-hour and 6-hour samples, respectively. However, colour was measured at 0 TCU for both samples in the field, and there was no visible colour at the time of sampling. For these reasons, the elevated colour reported in the lab samples is attributed to the elevated level of iron in the water, which decreased during the pump test, and is considered acceptable and treatable.
- The concentration of all other aesthetic, analytical and indicator parameters satisfies applicable criteria.

## 2.3 Fire Protection

For the detailed fire flow assessment, please see the attached report titled: “Fire Flow Assessment,” Report for 8520 McArton Road, Ottawa, prepared by EAU Structural & Environmental Services in December 2022. As the City of Ottawa accepts the conclusions of the Fire Flow Assessment report (Dec-2022). However, the minimum storage tank that would be acceptable by the City is a 10,000 Imperial gallon tank (45,460.9 litres). Appendix A, Figure 6.1 shows the details of the proposed precast concrete tank with 50,000 litres storage capacity.

## 2.4 Sanitary Servicing

No sanitary sewers are servicing in this area of the City. The proposed sanitary system includes two septic tanks and two pumps, one septic tank and a pump for the building and one septic tank and a pump for the aviaries, which are connected to one leaching bed. The septic system's design is re-submitted to OSSO for a revised flow of 6500L/day (<10000 L/day). As per Ontario Building Code (OBC), Clause 8.1.2.1, the septic system would consist of a conventional Class 4 leaching bed system. Its detailed design will be reviewed and approved by the City of Ottawa at the construction time. Refer to the servicing drawing SS-1 for the envelope of the septic system.

### 2.4.1 Sanitary Servicing for the Building

The building sewage demand is estimated based on the maximum daily water demand. As follows:

- i. The maximum number of employees is twenty (20), including six (6) practitioners, and assuming a maximum of 10 cages.
- ii. As per OBC, Table 8.2.1.3.B, Item 25, the maximum daily water demand is:

$$Q_{\text{daily}} = 6 \times 275 + (20-6) \times 75 + 10 \times 75 = 3,450 \text{ liters / day}$$

- iii. As per OBC, Clause 8.2.2.3. (1) (a), the minimum working capacity of a septic tank is 2.5 times the wastewater demand. As a conservative option, the capacity of a septic tank is proposed to be 3.0 times the wastewater demand:

$$V_{\text{STank}} = 3 \times 3,450 = 10,450 \text{ liters}$$

- iv. Use a septic tank the size of 12,500 litres for the building (see drawing SS-1 for the locations of the septic system parts).

### 2.4.2 Servicing for Outdoor Aviaries

In the proposed design, the Birds Aviaries have a wooden roof covering half of their area (50% of their total area). The aggregate wastewater demand results from the accumulated rainwater and the required water for washing the aviaries' concrete floors and the walkway between the aviaries and the building. The rainwater from the wooden roofs is drained directly (by individual gutters) to the grass area on the west and south green zones. The design of the Birds Aviaries combined storm-and-sewage system is based on two assumptions: (i) the events of cleaning the aviaries and the peak rain are not simultaneous, and (ii) the peak rain generates the dominant water discharge. These two assumptions are based on (a) the centre's staff controls the cleaning activities where the cleaning event is to be scheduled for no rain or during light rain occurrence; (b) continuous light rain would generate accumulated stormwater added to the combined storm-and-sewage system; however, it will be much lower than that quantity generated by an extreme hundred-year storm event; (c) As per Ontario Building Code, the demand is calculated for one day while the septic tank volume is estimated as 2.5 times the daily demand; (d) The concept behind the "2.5" times of the daily demand in the septic tank design is based on the biodegradation and deposition of solid biowaste (mostly human waste); (e) The septic tank stationary time (2.5 days) for biodegradation and deposition of solid waste is not applied on the bird biowaste; the bird biowaste is much less in volume, and their biodegradation and deposition are faster than those for the human, hence the volume for septic tank for the the birds aviaries should be be much less that 2.5 times of the daily demand; and (f) as the storm water add more fresh water that help in partially accelerating the waste biodegradation and deposition and ease its transport from the aviaries to the septic tank.

The sewers and the septic tank are designed to serve both; stormwater and sewage generated from aviaries' cleaning.

$$\text{Area of the Aviaries } (A_{\text{BC}}) = 253.3 \text{ m}^2$$

It is important to notice here that the volume of the sewage is much smaller than the water volume generated from the peak stormwater. The birds are moved to the aviaries when they are fully recovered. The number of expected birds in each aviary is small, and they are left for a short time before they are released into the wild. Each aviary cleaning occurs in periods depending on the birds' types, and the required water is in the range of 50-100 L. Even if we ignore the fact that the probability of cleaning all the aviaries at the same time is very small, the maximum accumulated volume of sewage in one day could not exceed 1000 L, given that most of these aviaries are small (please see Drawing SS-1).

Typically the service life of the building in the Ontario Building Design Code is limited to 50 years, where all the building and the service components are usually designed accordingly. However, as per the advice of the Development Review Unit, planning, Real Estate and Economic Development Department, The City of Ottawa, the return period for the rain intensity used to design the combined storm-and-sewage system of the Birds Aviaries is considering five years and hundred years design storm.

Rain intensities for five years storm for  $T_c = 15$  mins

Intensity,  $I_5 = 998.071 / (T_c + 6.035)^{0.814}$  (5-year, City of Ottawa):

$$I_5 = 83.615 \text{ mm/hr}$$

Rain intensities for hundred years storm for  $T_c = 15$  mins

Intensity,  $I_{100} = 1735.688 / (T_c + 6.014)^{0.820}$  (100-year, City of Ottawa):

$$I_{100} = 142.894 \text{ mm/hr}$$

Total rainwater accumulated over the concentration-time of 15 mins is:

$$Q_5 = (A_{BC}/2) \times I_5 \times (T_c/60) = (253.3 \text{ m}^2) \times (83.615 \text{ (mm/hr)} / 1000 \text{ (mm/m)}) \times (15 \text{ min} / 60 \text{ (min/hr)}) = 2.65 \text{ m}^3 / \text{hr}$$

The peak discharge per second is  $= 2.65 \text{ (m}^3 / \text{hr)} \times 1000 \text{ (L/m}^3) / (60 \times 60 \text{ (sec/hr)}) = 0.7354 \text{ L/sec}$

$$Q_{100} = (A_{BC}/2) \times I_{100} \times (T_c/60) = (253.3/2) \times (142.894 / 1000) \times (15/60) = 4.524 \text{ m}^3 / \text{hr}$$

The peak discharge per second is  $= 4.524 \times 10^3 / (60 \times 60) = 1.257 \text{ L/sec}$

The maximum total accumulated stormwater (or the demand) due to peak design storms is:

$$Q_{D100} = Q_{100} \text{ (L/sec)} \times (15 \text{ min}) \times 60 \text{ (sec/min)} = 1,131.3 \text{ L}$$

This quantity of water is generated in only 15 mins with a peak design rain storm intensity of 142.894 mm/hr. Hence the accumulated precipitation is equal to  $(142.894 \text{ mm/hr}) \times (15 \text{ min} / 60 \text{ min/hr}) = 35.724 \text{ mm}$ . Suppose we assume additional accumulated stormwater due to light rain over the rest of the day before and after the peak design rain intensity, which increases the daily accumulated rain to 50 mm/day. In this case, the accumulated additional stormwater is:

$$Q_{\text{add}} = (A_{BC}/2) \times (50 - 35.724) = (253.3 \text{ m}^2) \times (14.276 \text{ mm/day} / 1000 \text{ (L/m}^3)) = 1.808 \text{ m}^3 = 1,808 \text{ L}$$

$$Q_{\text{Aviaries}} = Q_{D100} + Q_{\text{add}} = 1,131.3 + 1,808 = 2,939.3 \text{ L/day}$$

$$\text{Required Septic Tank Size} = 2.5 \times 2,939.3 = 7,348.25 \text{ L}$$

125 mm diameter sanitary sewers are proposed with a minimum slope of 1.5 %, having a Manning's full flow capacity of 3.5 L/sec. The pipes progressively accumulate the

wastewater from the aviaries floors by inlets (SWTC-A1 through STWC-A18 and STWC-B1). Three manholes are provided (SST-MH-1 through SST-MH-3).

As per the Ontario Building Code, the septic tank size for the building is 2.5 times the wastewater demand, around 8000 litres. Since most of the wastewater is rainwater, and because of the nature of the birds' wastes, the septic tank size for the aviaries can be reduced. As stated earlier, cleaning the aviaries and the peak rain is not simultaneous; the peak rain generates the dominant water discharge. Cleaning the aviaries moves most of the birds' waste to the septic tank. The rainstorm water is only moving some waste that occasionally exists between two cleaning events. Since the water drained to the septic tank during a peak rain, it does not need to remain the entire time of 2.5 days. Despite this rationale that leads to reducing the volume of the septic tank for the aviaries, the septic tank volume will keep at 8000 L as advised by the City of Ottawa Engineers.

The background assumption here is that peaks of the two demands of the water pumped to the leaching bed (from the building septic tank and the Birds Aviaries septic tank) are not simultaneous.

### **3. STORMWATER MANAGEMENT**

#### **3.1 Design Criterion**

The storm flow is calculated in conformance with the latest version of the City of Ottawa Design Guidelines (October 2012). As the site is located in a very rural zone, The post-development flow is compared to the allowable release (i.e. the pre-development flow) rate for the site for 5-year and 100-year storm events using a time of concentration of 10 minutes and runoff coefficients as calculated in Table 7.1 and Table 7.4 of Appendix B. Flows in excess of the 5- year and the 100-year rate are detained on-site using on-site storage.

#### **Minor Design Criteria**

- The storm flow, Stormceptor inlet, and site open storage are designed and/or sized based on the Modified Rational Method for the 5-year and 100-year storms using a 10-minute inlet time.
- Inflow rates into the minor system are limited to an allowable release rate, as noted above.

#### **Major Design Criteria**

- The major storm flow, Stormceptor inlet, and site open storage are designed and/or sized to accommodate on-site detention with sufficient capacity to attenuate the 100-year design storm. The excess runoff above the 100-year event will flow over a proposed riprap as per OPSD 810.010 (TYPE B) shown in drawing SS-1, GR-1, and WS-1.
- On-site surface storage is provided for up to the 100-year design storm by grading the area around the swale, forming an instantaneous pond (storage) that allows slow



flow release avoiding possible local flood. The required on-site storage volumes are supported by detailed calculations in Appendix B.

- The required storage volumes have been calculated based on the Modified Rational Method, as identified in Section 8.3.10.3 of the City's Sewer Guidelines. The details of the surface storage are illustrated on the site servicing and grading plans (SS-1 and GR-1).

**Water Quality:** Enhanced, 80% total suspended solids (TSS) removal and quality control are required for institutional developments per the Rideau Valley Conservation Authority requirements. Detailed information and hydraulic data, and water quality are provided by Geofirma Engineering Ltd. final report titled "Hydrogeological Study/ 8520 McArton Road, Ottawa, Ontario", on April 30, 2020.

**Method of Analysis:** The Modified Rational Method has been used to calculate the runoff rate from the drainage catchment to quantify the detention storage for all controlled measures. Refer to Appendix B for all stormwater calculations.

The stormwater management criteria for this development are based on the City of Ottawa Sewer Design Guidelines (2012), and the Ministry of the Environment (MOE) Stormwater Management Planning and Design Manual (2003).

### 3.2 Pre-Development Release Rate

The calculations of pre-development peak flows were estimated to ensure that the allowable release rate was less than pre-development conditions. Under pre-development conditions, the site consisted entirely of grass. From the existing ground elevations shown on the grading plan, storm runoff flowed westerly to the gravel lane behind the site.

For the calculations of pre-development runoff coefficients, the area to be developed is 8183.1 m<sup>2</sup> divided into two types: paved and grassed. The first is the existing asphalted entry with an area of 78 m<sup>2</sup>, named the first watershed, EWS-01, and the second is a wide grassed area of 8105.1 m<sup>2</sup>. Based on the future development plans and to calculate the allowable release, the grassed area is hypothetically divided into four sub-watersheds, EWS-02, EWS-03A, EWS-03B, and EWS-03C with areas of 3227 m<sup>2</sup>, 987.1 m<sup>2</sup>, 1994 m<sup>2</sup>, and 1975 m<sup>2</sup>, respectively. This division is essential to calculate the post-development excess flow (see section 3.4).

The pre-development runoff coefficient of the 5-year storm event for EWS-01 is assumed to be 0.9, and for EWS-02, EWS-03A, EWS-03B, and EWS-03C is 0.3. The pre-development runoff coefficient of the 100-year storm event for EWS-01 is assumed to be 1.0, and for EWS-02, EWS-03A, EWS-03B, and EWS-03C is 0.375. The overall site pre-development runoff coefficient was determined to be 0.306 for a 5-year storm and 0.381 for a 100-year storm, with calculations shown below and summarized in Appendix B, Table 7.1. It is important to mention here that the pre-development runoff coefficient of the 100-year storm event is increased by 25% over the 5-year runoff coefficient.

Using a time of concentration ( $T_c$ ) of 15 minutes and an average runoff coefficient of 0.306, the pre-development peak runoffs release rates from the site are determined for the 5-year and 100-year storms using the Rational Method as follows:

$$Q_{PRE} = 2.78 C I A$$

Where:

$Q_{PRE}$	=	Pre-development Peak Discharge (L/sec)	
$C_{AVG}$	=	Average Runoff Coefficient	
$I$	=	Average Rainfall Intensity for a return period (mm/hr)	
	=	$998.071 / (T_c + 6.053)^{0.814}$ (5-year)	
	=	$1735.688 / (T_c + 6.014)^{0.820}$ (100-year)	
$T_c$	=	Time of concentration (mins)	
$A$	=	Drainage Area (hectares)	
Therefore: $I_{5PRE}$	=	$998.071 / (15 + 6.053)^{0.814}$	= 83.62 mm/hr
$Q_{5PRE}$	=	$2.78 (0.31) (83.62 \text{ mm/hr}) (0.8265 \text{ ha})$	= 58.697 L/sec
$I_{100PRE}$	=	$1735.688 / (15 + 6.014)^{0.820}$	= 142.894 mm/hr
$Q_{100PRE}$	=	$2.78 (0.3821) (142.894 \text{ mm/hr}) (0.8265 \text{ ha})$	= 125.000 L/sec

The overall site's 5-year and 100-year pre-development flow was estimated at 58.697 L/sec and 125.000 L/sec, respectively. The peak runoff release details for each of the four sub-watersheds, EWS-02, EWS-03A, EWS-03B, and EWS-03C, are shown in Table 7.2 of Appendix B.

### 3.3 Calculation of Allowable Release Rate

The total site area is about 7ha. The only area around the proposed development is considered in this calculation, as the remainder of the property towards the south will remain untouched. The total area of the site development portion accounted for in this calculation is 0.8183.1 ha.

The site is divided into five watersheds, EWS-01, EWS-02, EWS-03A, EWS-03B, and EWS-03C. EWS-01 has a total area of 0.0078 ha and drains towards the roadside ditch. EWS-02, EWS-03A, EWS-03B, and EWS-03C account for most of the development zone, with a grassed area of 0.8105.1 ha. These four watersheds drain towards the exiting wetlands to the property's southeast portion. As mentioned earlier (see Section 3.2), the grassed area is hypothetically divided into four sub-watersheds, EWS-02, EWS-03A, EWS-03B, and EWS-03C, with areas of 3227 m<sup>2</sup>, 987.1 m<sup>2</sup>, 1994 m<sup>2</sup>, and 1975 m<sup>2</sup>, respectively.

The allowable release rate from the site development area is calculated for the 5-year and 100-year storm events with a pre-development runoff coefficient of 0.306 (or 0.31) for 5-Y

storms and 0.381 (or 0.38) for 100-Y storms, respectively. As per the City of Ottawa engineering review, the pre-development release rate for this rural site is based on a 100-year storm pre-level event. The City of Ottawa Sewer Design Guidelines (2012) specifies a time of concentration of 10 mins in greenfield developments with low grades and a lack of conveyance for the primary design criteria.

$$Q_{\text{ALLOW}} = 2.78 C I A$$

Where:

	$Q_{\text{ALLOW}}$	=	Peak Discharge (L/sec) Runoff	
	$C_{\text{AVG}}$	=	Average Runoff Coefficient	
	$I_{\text{ALLOW}}$	=	Average Rainfall Intensity for a return period (mm/hr)	
		=	$998.071 / (T_c + 6.053)^{0.814}$ (5-year)	
		=	$1735.688 / (T_c + 6.014)^{0.820}$ (100-year)	
	$T_c$	=	Time of concentration (mins)	
	$A$	=	Drainage Area (hectares)	
Therefore:	$I_{5\text{ALLOW}}$	=	$998.071 / (10 + 6.053)^{0.814}$	= 104.288 mm/hr
	$Q_{5\text{ALLOW}}$	=	$2.78 (0.306) (104.29 \text{ mm/hr}) (0.8183.1 \text{ ha})$	= 73.209 L/sec
	$I_{100\text{ALLOW}}$	=	$1735.688 / (10 + 6.014)^{0.820}$	= 178.559 mm/hr
	$Q_{100\text{ALLOW}}$	=	$2.78 (0.382) (178.56 \text{ mm/hr}) (0.8265 \text{ ha})$	= 156.198 L/sec

Hence, the allowable release rate from the overall site is 73.209 L/s for the 5-year storm event and 156.198 L/s for the 100-year storm event. The allowable release rate for watershed EWS-01 is 2.035 L/s for the 5-year storm event and 3.872 L/s for the 100-year storm event. The allowable release rate for watershed EWS-02 is 28.067 L/s for the 5-year storm event and 60.07 L/s for the 100-year storm event.

The allowable release rate for watershed EWS-03A is 8.585 L/s for the 5-year storm event and 18.375 L/s for the 100-year storm event. The allowable release rate for watershed EWS-03B is 17.343 L/s for the 5-year storm event and 37.118 L/s for the 100-year storm event. For detailed calculations of the release rates, see Table 7.3 of Appendix B. The allowable release rate for watershed EWS-03C is 17.178 L/s for the 5-year storm event and 36.764 L/s for the 100-year storm event. It is important to mention here that the east slope of the building roof drains to the swale of WS-02, while the west side of the building roof and the aviaries' roofs (the covered half of the aviaries) drain to the swale of WS-03B. Since the allowable runoff is the pre-development 100-year storm, the third sub-area has no increase in the stormwater after the development.

### 3.4 Calculation of Post-Development Release Rate

The site development area is divided into three (5) watersheds. Given that environmental control is required for the paved areas for any possible pollution, three of the watersheds are to be uncontrolled, and two are controlled watersheds (one watershed, WS-02, is environmentally controlled where an oil-grit separator is to be used before releasing the stormwater). WS-01 is a small uncontrolled area and will drain towards the roadside ditch. WS-01 is the same as the pre-development watershed EWS-01. WS-02 will be controlled and drained towards a proposed swale that will collect and convey the drainage towards an oil-grit separator (STC 750) using an inlet control device (ICD). WS-03A and WS-03C are controlled by matching the existing drainage path of the property. These watersheds (WS-03A and WS-03C) are the same area as the hypothetical pre-development watersheds EWS-03A and EWS-03C, which have 0.09871 ha and 0.09871 ha, respectively. Since the allowable runoff is the pre-development 100-year storm, the third sub-area has no increase in the stormwater after the development. The other zone, or WS-03B watershed, includes the west side of the sloped roof of the building and the aviaries' roofs (the covered half of the aviaries). The west side of the building roof and the aviaries' roofs increase the stormwater flow in watershed WS-03B compared to that of the pre-development watershed EWS-03B. The flow is directed to the west swale, and the stored water is released to the south wetland area.

This first ICD will control the WS-02 runoff to the allowable release rate for the 100-year storm events. The controlled flow will outlet to the STC and ultimately to the property's existing roadside ditch with a release rate to the pre-development rate of 60.07 L/Sec. The required on-site storage will be provided through on-site surface ponding within the proposed swale shown in drawing SS-1 and GR-1. The controlled site drainage is diverted towards the side-road ditch and away from the wetland to protect and preserve the wetland area. The second ICD controls the watershed zone WS-03B's release rate to the pre-development rate of 37.118 L/Sec. Refer to the Site Servicing Plan SS-1 for the proposed stormwater management layout and Watershed plan WS-1 for the proposed drainage catchment areas.

Using time of concentration ( $T_c$ ) of 10 minutes and average runoff coefficients as calculated in Table 7.4, the post-development release rates from the site are determined for the three watersheds for the 5-year and 100-year storms using the Rational Method as follows:

$$Q_{PRE} = 2.78 C I A$$

Where:

	$Q_{POST}$	=	Post-development Peak Discharge (L/sec)	
	$C_{AVG}$	=	Average Runoff Coefficient	
	$I$	=	Average Rainfall Intensity for a return period	(mm/hr)
		=	$998.071 / (T_C + 6.053)^{0.814}$ (5-year)	
		=	$1735.688 / (T_C + 6.014)^{0.820}$ (100-year)	
	$T_C$	=	Time of concentration (mins)	
	$A$	=	Drainage Area (hectares)	
Therefore:	$I_{5POST}$	=	$998.071 / (10 + 6.053)^{0.814}$	= 104.288 mm/hr
WS-01:	$Q_{POST5-WS-01}$	=	$2.78 (0.900) (104.288 \text{ mm/hr}) (0.0078 \text{ ha})$	= 2.035 L/sec
WS-02:	$Q_{POST5-WS-02}$	=	$2.78 (0.531) (104.288 \text{ mm/hr}) (0.3227 \text{ ha})$	= 49.725 L/sec
WS-03A	$Q_{POST5-WS-03}$	=	$2.78 (0.300) (104.288 \text{ mm/hr}) (0.0987 \text{ ha})$	= 8.585 L/sec
WS-03B	$Q_{POST5-WS-03}$	=	$2.78 (0.508) (104.288 \text{ mm/hr}) (0.1994 \text{ ha})$	= 29.366 L/sec
WS-03C	$Q_{POST5-WS-03}$	=	$2.78 (0.300) (104.288 \text{ mm/hr}) (0.1975 \text{ ha})$	= 17.178 L/sec
Overall Site	$Q_{POST5-Overall}$	=	$2.78 (0.446) (104.288 \text{ mm/hr}) (0.8261 \text{ ha})$	= 106.890 L/sec
	$I_{100POST}$	=	$1735.688 / (10 + 6.014)^{0.820}$	= 178.559 mm/hr
WS-01:	$Q_{POST100-WS-01}$	=	$2.78 (1.000) (178.559 \text{ mm/hr}) (0.0078 \text{ ha})$	= 3.872 L/sec
WS-02	$Q_{POST100-WS-02}$	=	$2.78 (0.616) (178.559 \text{ mm/hr}) (0.3227 \text{ ha})$	= 98.697 L/sec
WS-03A	$Q_{POST100-WS-03}$	=	$2.78 (0.375) (178.559 \text{ mm/hr}) (0.0987 \text{ ha})$	= 18.375 L/sec
WS-03B	$Q_{POST100-WS-03}$	=	$2.78 (0.592) (178.559 \text{ mm/hr}) (0.1994 \text{ ha})$	= 58.561 L/sec
WS-03C	$Q_{POST100-WS-03}$	=	$2.78 (0.375) (178.559 \text{ mm/hr}) (0.1975 \text{ ha})$	= 36.764 L/sec
Overall Site	$Q_{POST100-Overall}$	=	$2.78 (0.527) (104.288 \text{ mm/hr}) (0.8261 \text{ ha})$	= 216.268 L/sec

Table 7.5 details the calculations for the estimations of the five watershed areas' 5-year and 100-year post-development peak flows, where the concentration time is 10 minutes. Table 7.6 details the calculations for the estimations of the 5-year and 100-year post-development flows' increase of the five watershed areas. Using time of concentration (TC) of 10 minutes and average runoff coefficients as calculated in Table 7.4. Table 3.1 summarizes each watershed's pre-development release flows, post-development release flows, and overall site flows.

**Table 3-1 – Summary of Post-Development Flows Compared to Pre-Development Flows**

No.	Sub-Watershed	Area (ha)	Storm: 5 Y		Storm: 100 Y	
			Q <sub>5PRE</sub> (L/Sec)	Q <sub>5POST</sub> (L/Sec)	Q <sub>100PRE</sub> (L/Sec)	Q <sub>100POST</sub> (L/Sec)
1	WS-01	0.0078	2.035	2.035	3.872	3.872
2	WS-02	0.3227	28.067	49.725	60.070	98.697
3	WS-03A	0.0987	8.585	8.585	18.375	18.375
	WS-03B	0.1994	17.343	29.366	37.118	58.561
	WS-03C	0.1975	17.178	17.178	36.764	36.764
<b>Overall Site</b>		0.8261	73.209	106.920	156.198	216.268

### 3.5 Storage Requirements

Comparing post-development with allowable release rates for the three watersheds, WS-01, WS-02, WS-03A, WS-03B and WS-03C, with the Allowable Runoff, for a time concentration of 10 mins for 100-year storms, the increase in the release rate due to the development is quantified. This comparison compares the pre-development, and the post-development flows for a 5-year design storm and a 100-year design storm. Table 3.2 summarizes this comparison between the post-development and the allowable release rates for 5-year and 100-year design storms. Watershed WS-1 is of uncontrolled flow release toward the roadside ditch at the north of the site. The watershed WS-02 involves a large paved zone and the east part of the building roof, and hence its flow is controlled. The runoff increase due to the development of watershed WS-02 is 21.658 L/Sec for a 5-year design storm and 38.627 L/Sec for a 100-year design storm. Table 7-6 of Appendix B shows the detailed calculations of the excess runoff due to the proposed development. Watershed WS-03B is also controlled flow as shown in Table 3-2, includes the west side of the building and the aviaries sub-area, and a green sub-area. The runoff increase due to the development of watershed WS-03B is 12.023 L/Sec for a 5-year design storm and 21.443 L/Sec for a 100-year design storm. The flows for each sub-area and for the overall Watershed WS-03 are shown in Table 3-2.

**Table 3-2 – Summary of Flows Runoff increase due to Post-Development**

No.	Area Name	Area (ha)	Allowable Runoff		P-D Increase of Runoff	
			Q <sub>ALL5</sub> (L/Sec)	Q <sub>ALL100</sub> (L/Sec)	Q <sub>INC5</sub> (L/Sec)	Q <sub>INC100</sub> (L/Sec)
1	WS-01	0.0078	2.035	3.872	0.000	0.000
2	WS-02	0.3227	28.067	60.070	21.658	38.627
3	WS-03A	0.0987	8.585	18.375	0.000	0.000
4	WS-03B	0.1994	17.343	37.118	12.023	21.443
5	WS-03C	0.1975	17.178	36.764	0.000	0.000
<b>Overall Site</b>		<b>0.8265</b>	<b>0.8261</b>	<b>73.209</b>	<b>33.681</b>	<b>60.070</b>

The required surface storages are calculated based on maintaining the same allowable release rate for watershed WS-02 and watershed WS-03B for both the 5-year design storm and the 100-year design storm, where the 100-year design storm controls the design. Table 7-7 and 7.8 of Appendix B shows the detailed calculations for the required surface storage volume for using the Modified Rational Method for watershed WS-02 and watershed WS-03B, respectively. Table 7-7 shows that 12.967 m<sup>3</sup> storage volume is required for the 5-year design storm, and 23.163 m<sup>3</sup> storage volume is required for the 100-year design storm for watershed WS-02. On the other hand, Table 7-8 shows that 7.215 m<sup>3</sup> storage volume is required for the 5-year design storm, and 12.887 m<sup>3</sup> storage volume is required for the 100-year design storm for watershed WS-03B.

Following is a sample calculation of required storage:

**Storage**<sub>XXX-year storm</sub> = Duration x Storage Rate = (T<sub>D</sub> (min) X 60 (sec/min)) X (Storage Rate (L/sec)) / (1000 L/m<sup>3</sup>)

**Storage Required**<sub>5-year storm</sub> = (10 (min) X 60 (sec/min)) X 21.612 (L/sec) / (1000 L/ m<sup>3</sup>)  
= 12.967 m<sup>3</sup>

**Storage Required**<sub>100-year storm</sub> = (10 (min) X 60 (sec/min)) X 38.605 (L/sec) / (1000 L/ m<sup>3</sup>)  
= 23.163 m<sup>3</sup>

### 3.6 ICD/ Orifice Design

As per Ottawa Sewer Design Guidelines, the following equation shall be used to compute the release rate from an orifice inlet control device ICD (plate or plug type):

$$Q = 0.61 \times A \times \sqrt{2 \times g \times H}$$

Where:

Q = Release rate (m<sup>3</sup>)

A = Area of the orifice (m<sup>2</sup>)

g = Gravitational acceleration (9.81 m/s<sup>2</sup>)

H = Head above the centerline of the orifice (m)

Table 7-9 shows the detailed calculations for the ICDs at the end of the stormwater surface storage of Watershed WS-02, while Table 7-10 shows the detailed calculations for the ICDs at the end of the stormwater surface storage of Watershed WS-03B.

### 3.7 Proposed Stormwater Management Plan

#### 3.7.1 Proposed Runoff Flow Quantity Controls

The runoff flow of the proposed development site will be managed by two means; grading toward the wetland for around 36.8% of the site area and using proposed swales and control structures for the rest 63.2% of the site area. WS-01, WS-03A and WS-03C having a total area of 0.30401 ha, will have an open (uncontrolled) drain into the wetland following

the grading, as shown in drawing GR-1. However, watershed WS-02 and watershed WS-03B drainage are to be managed using a storm system.

The 5-year and 100-year storm events have been analyzed. It was found that the 100-year storm governs the storm design. Hence the storm system was designed accordingly. The storm system is formed from proposed swales, surface storages, and a control structures (see drawings SS-1, GR-1, and WS-1). The runoff will be controlled by an ICD located at the headwall at the north end of the WS-02 swale and at the south end of the WS-03B swale. For WS-02 and during the 5-year event, the controlled portion of the site development area will release a runoff rate of 28.07 L/Sec, and a runoff rate of 60.07 L/Sec at a maximum head of 0.60 m. For WS-03B and during the 5-year event, the controlled portion of the site development area will release a runoff rate of 17.34 L/Sec, and a runoff rate of 37.118 L/Sec at a maximum head of 0.50 m.

The first ICD is to be installed and centred in the inlet leading to the stormceptor. The 100-year high water level (HWL) is expected to be at 134.90 masl. With the use of this ICD. The total release rate from the WS-02 controlled area for the 100-year storm event will be 60.070 L/s, which requires 23.163 m<sup>3</sup> of storage volume. The needed storage will also be provided as surface ponding storage in the proposed swale. The total storage volume provided is 28 m<sup>3</sup> for 100Y +20%.

The second ICD is to be installed and centred in a small dam at the outlet leading to the south wetland. The 100-year high water level (HWL) is expected to be at 134.50 masl. With the use of this ICD. The total release rate from the grassed area, west side of the building, and the aviaries of watershed WS-03B controlled area for the 100-year storm event will be 37.118 L/s, which requires 12.887 m<sup>3</sup> of storage volume. The needed storage will also be provided as surface ponding storage in the proposed swale. The total storage volume provided is 15.5 m<sup>3</sup> For 100Y +20%.

### 3.7.2 Proposed Quality Controls

Enhanced quality control providing 80% TSS removal will be accomplished using a stormceptor (STC-750). The STC-750 will be located east of the development area, which will then discharge to the existing roadside ditch. Rip-rap will be used to prevent erosion at the stormceptor outlet. Based on the anticipated flow rates, the STC750 will provide 84% TSS removal. Therefore, on-site quality control is achievable and has been designed accordingly. Refer to Site Servicing Plan drawing SS-1 for the stormceptor location and Appendix C for the stormceptor sizing, maintenance, and technical manual- Canada.

It is noted that it will be the owner's responsibility to ensure the adequate operation & maintenance of the stormceptor. If inspection indicates the potential need for maintenance, access is provided via the manhole lid of the Stormceptor. Maintenance is accomplished with the use of a sump vac. Refer to Appendix C for manufacturer maintenance schedule recommendations.



#### 4. EROSION AND SEDIMENT CONTROL

During all construction activities, erosion and sedimentation shall be controlled by the following techniques:

- Install a light-duty silt fence barrier along the perimeter of the property to capture any sediments from leading into the ditch.
- Strawbales are to be placed at the downstream end of any existing swales to act as a filtering agent.
- Daily visual inspection of sediment control barriers shall be completed, and any damage will be repaired immediately. Care is to be taken to prevent damage during construction operations.
- In some cases, barriers may be removed temporarily to accommodate the construction operations. The affected barriers are to be reinstated at night when construction is completed.
- The sediment control devices are to be cleaned of accumulated silt as required. The deposits will be disposed of as per the requirements of the contract,
- During the course of construction, if ADAD Inc. performs an inspection and believes that additional prevention methods are required to control erosion and sedimentation, the contractor shall install additional silt fences or other methods as required to the satisfaction of the ADAD Inc. civil engineering team.
- Sediment control measures are to remain in place throughout the entire construction phase and monitored/maintained on a regular basis until all disturbed areas have been fully restored or vegetated.

For more details, refer to the erosion and sediment control plan (ES-1).

## 5. SUMMARY & CONCLUSIONS

Based on the information presented in this report, the proposed civil engineering design ensures that stormwater management requirements for this site are achievable. The following is a summary of the stormwater management plan for this site:

- The project consists of constructing a 623.25 m<sup>2</sup> building along with 25 parking spots.
- The building will be serviced with a conventional septic system that was designed and approved by Ottawa Septic System Office (OSSO Septic File # 21-558).
- The property will have water service using a drilled well.
- Fifty thousand liters (>10,000 Imperial gallons) will be provided through a precast reinforced concrete tank elevated above ground level to enable gravity water flow for fire protection.
- The allowable release rate for watershed EWS-01 is 2.035 L/s for the 5-year storm event and 3.872 L/s for the 100-year storm event. The allowable release rate for watershed EWS-02 is 28.067 L/s for the 5-year storm event and 60.070 L/s for the 100-year storm event. The allowable release rate for watershed EWS-03A is 8.585 L/s for the 5-year storm event and 18.375 L/s for the 100-year storm event. The allowable release rate for watershed EWS-03B is 17.343 L/s for the 5-year storm event and 37.118 L/s for the 100-year storm event. The allowable release rate for watershed EWS-03C is 17.178 L/s for the 5-year storm event and 36.764 L/s for the 100-year storm event.
- The 100-year post-development release flow rate of controlled watershed WS-02 is at the same quantitative level as the 100-year pre-development rate, and the 5-year post-development release flow rate is at the same quantitative level as the 5-year pre-development rate.
- The runoff flow of the proposed uncontrolled watersheds WS-01, WS-03A and WS-03C of the development site will be managed by grading mainly toward the wetland.
- Using the Modified Rational Method, the uncontrolled watersheds WS-01, WS-03A and WS-03C will release a maximum allowable runoff rate of 3.872 L/Sec, 18.375 L/Sec and 36.764 L/Sec, respectively.
- ICD will organize the controlled watershed WS-02 to a maximum allowable rate of 60.07 L/Sec during the 100-year storm event, thereby meeting the estimated allowable release rate. ICD will organize the controlled watershed WS-03B to a maximum allowable rate of 37.118 L/Sec during the 100-year storm event, thereby meeting the estimated allowable release rate.

- The ICD that will be located within the stormceptor inlet with an invert of 134.00 masl, producing a HWL of 134.7 masl during the 100-year storm event.
- For watershed WS-02, the required storage volume capacities are 12.967 m<sup>3</sup>, 23.163 m<sup>3</sup>, and 27.8 m<sup>3</sup> for 5 Y Storm, 100 Y storm, and 100Y+20%, respectively. Accordingly, a total storage volume of 30 m<sup>3</sup> will be created above ground as ponding within the proposed swale.
- For watershed WS-03B, the required storage volume capacities are 7.215 m<sup>3</sup>, 12.887 m<sup>3</sup>, and 15.5 m<sup>3</sup> for 5 Y Storm, 100 Y storm, and 100Y+20%, respectively. Accordingly, a total storage volume of 17 m<sup>3</sup> will be created above ground as ponding within the proposed swale.
- Enhanced quality control of 80% TSS removal is required for watershed WS-02. A stormceptor model STC-750, has been sized to provide 84% TSS removal, thereby meeting quality control requirements.



Husham Almansour, P.Eng, Ph.D.



## **6. APPENDIX A: DETAILS OF A PRECAST CONCRETE FIRE PROTECTION TANK**

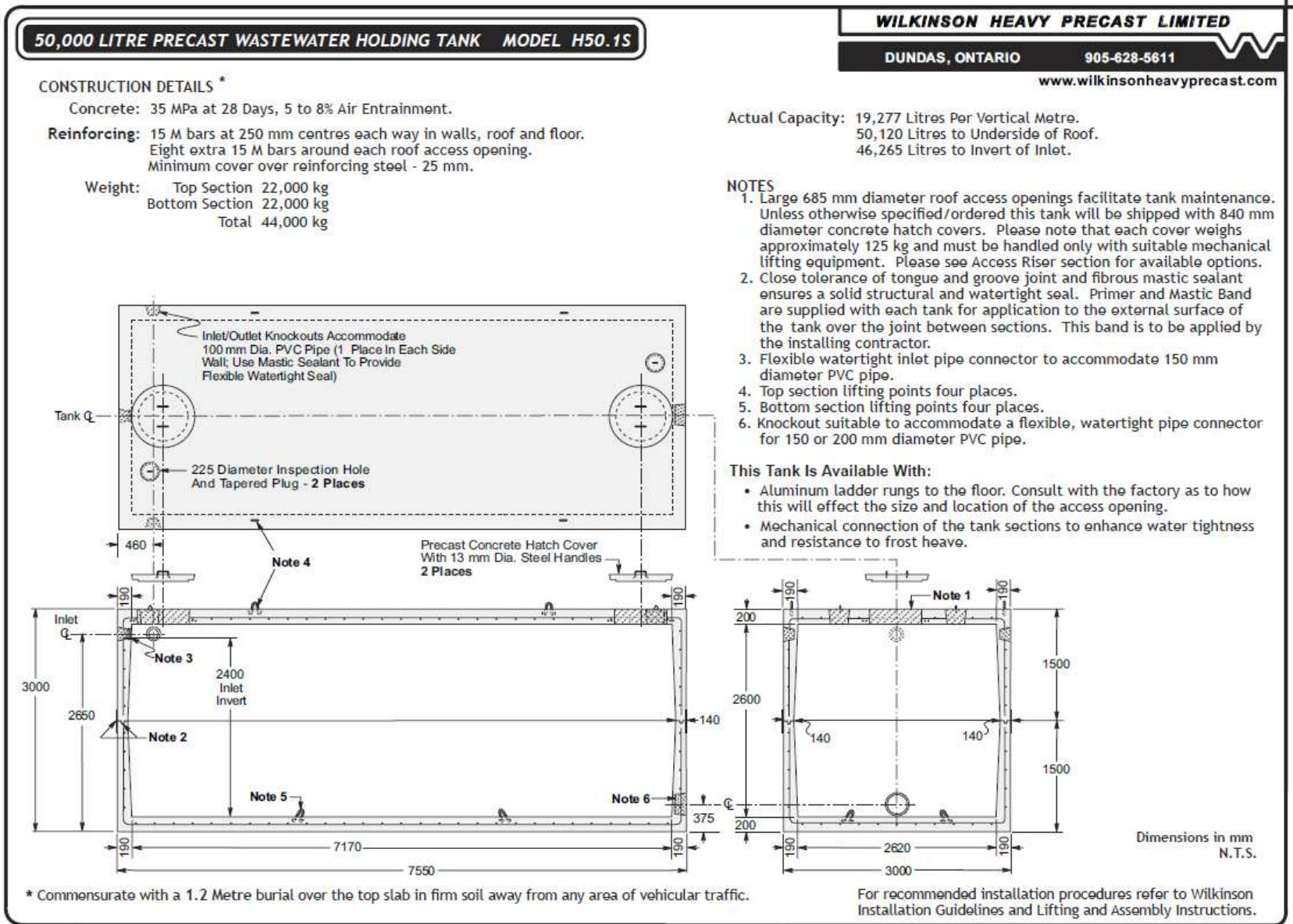

Figure 6-1 – Details of a Precast Concrete Fire Protection Tank with a 40,000 L Capacity

## **7. APPENDIX B: STORMWATER MANAGEMENT DESIGN SHEETS/ TABLES**

**Table 7-1 – Calculations of Average Runoff Coefficients (Pre-Development)**

No	Area Name	Area Type	Areas (m <sup>2</sup> )	C <sub>x</sub>	C <sub>x</sub> Value 5-Y Storm	Sum of (A x Cx) 5-Y Storm	C <sub>x</sub> Value 100-Y Storm	Sum of (A x Cx) 100-Y Storm
1	EWS-01	Asphalt/ Pavers	78	C <sub>ASPH</sub>	0.900	70.200	1.000	78.000
2	EWS-02	Grassed	3227	C <sub>GRASS</sub>	0.300	968.100	0.375	1210.125
3	EWS-03A	Grassed	987.1	C <sub>GRASS</sub>	0.300	296.130	0.375	370.163
4	EWS-03B	Grassed	1994	C <sub>GRASS</sub>	0.300	598.200	0.375	747.750
5	EWS-03C	Grassed	1975	C <sub>GRASS</sub>	0.300	592.500	0.375	740.625
EWS-02 & EWS-03A,B,C		Grassed	8183.1	C <sub>GRASS</sub>	0.300	2454.930	0.375	3068.663
<b>Oveall Area</b>						<b>8261.1</b>		
<b>Average Runoff Coefficients (Pre-Development) C<sub>AVG-Pre (5Y)</sub></b>						<b>0.306</b>		
<b>Average Runoff Coefficients (Pre-Development) C<sub>AVG-Pre (100Y)</sub></b>								<b>0.381</b>

**Table 7-2 – Calculations of Peak Runoff (Pre-Development)**

Area Discription	Area (ha)	Time of Concentration, Tc (min)	Storm: 5 Y			Storm: 100 Y		
			I <sub>5</sub> (mm/hr)	C <sub>AVG5</sub>	Q <sub>PRE5</sub> (L/Sec)	I <sub>100</sub> (mm/hr)	C <sub>AVG100</sub>	Q <sub>PRE100</sub> (L/Sec)
EWS-01	0.0078	15	83.615	0.900	1.632	142.894	1.000	3.099
EWS-02	0.3227	15	83.615	0.300	22.504	142.894	0.375	48.072
EWS-03A	0.09871	15	83.615	0.300	6.884	142.894	0.375	14.705
EWS-03B	0.1994	15	83.615	0.300	13.905	142.894	0.375	29.704
EWS-03C	0.1975	15	83.615	0.300	13.773	142.894	0.375	29.421
<b>Overall Site</b>	<b>0.82611</b>	<b>15</b>	<b>83.615</b>	<b>0.306</b>	<b>58.697</b>	<b>142.894</b>	<b>0.381</b>	<b>125.000</b>

**Notes:**

- 1) Intensity, I = 998.071/(Tc+6.035)<sup>0.814</sup> (5-year, City of Ottawa)
- 2) Intensity, I = 1735.688/(Tc+6.014)<sup>0.820</sup> (100-year, City of Ottawa)
- 3) Cavg for 100-year is increased by 25%, with maximum of 1.00



**Table 7-3 – Calculations of Allowable Runoff (Pre-Development)**

No.	Area Discription	Area (ha)	Time of Concentration, Tc (min)	Storm: 5 Y			Storm: 100 Y		
				I <sub>5</sub> (mm/hr)	C <sub>AVG-Pre-5</sub>	Q <sub>PRE5</sub> (L/Sec)	I <sub>100</sub> (mm/hr)	C <sub>AVG-Pre-100</sub>	Q <sub>PRE100</sub> (L/Sec)
1	EWS-01	0.0078	10	104.288	0.900	2.035	178.55902	1.000	3.872
2	EWS-02	0.3227	10	104.288	0.300	28.067	178.55902	0.375	60.070
3	WS-03A	0.09871	10	104.288	0.300	8.585	178.55902	0.375	18.375
4	WS-03B	0.1994	10	104.288	0.300	17.343	178.55902	0.375	37.118
5	EWS-03C	0.1975	10	104.288	0.300	17.178	178.55902	0.375	36.764
<b>Overall Site</b>		<b>0.82611</b>	<b>10</b>	<b>104.288</b>	<b>0.306</b>	<b>73.209</b>	<b>178.55902</b>	<b>0.246</b>	<b>156.198</b>

**Notes:**

- 1) Allowable Capture Rate is based on 5-year storm with T<sub>CONC</sub> = 10 mins
- 2) Intensity, I = 998.071/(Tc+6.035)<sup>0.814</sup> (5-year, City of Ottawa)
- 3) Intensity, I = 1735.688/(Tc+6.014)<sup>0.820</sup> (100-year, City of Ottawa)
- 4) Cavg for 100-year is increased by 25%, with maximum of 1.00

**Table 7-4 – Calculations of Average Runoff Coefficients (Post-Development)**

No.	Area Name	Area Type	Areas (m <sup>2</sup> )	C <sub>x</sub>	C <sub>x5</sub> Value	Sum of (A x C <sub>x5</sub> )	C <sub>x100</sub> Value	Sum of (A x C <sub>x100</sub> )
1	WS-01	Asphalt/ Pavers	78	C <sub>01</sub>	0.900	70.2	1.000	78.00
2	WS-02 <sub>1</sub>	Asphalt/ Pavers	1036	C <sub>02-1</sub>	0.900	932.4	1.000	1036.00
	WS-02 <sub>2</sub>	Building Roofs- East side	209.05	C <sub>02-2</sub>	0.900	188.145	1.000	209.05
	WS-02 <sub>3</sub>	Grassed	1981.95	C <sub>02-3</sub>	0.300	594.585	0.375	743.23
	WS-02	<b>Total WS-02</b>	<b>3227</b>	<b>C<sub>02</sub></b>	<b>0.531</b>	<b>1715.13</b>	<b>0.616</b>	<b>1988.28</b>
3	WS-03A	Grassed	987.1	C <sub>03A</sub>	0.300	296.13	0.375	370.16
4	WS-03B <sub>1</sub>	Building Roofs- West Side	564.15	C <sub>03B-1</sub>	0.900	507.735	1.000	564.15
	WS-03B <sub>2</sub>	Birds Cages roofs	127	C <sub>03B-2</sub>	0.900	114.3	1.000	127.00
	WS-03B <sub>3</sub>	Grassed	1302.85	C <sub>03B-3</sub>	0.300	390.855	0.375	488.57
	WS-03B	<b>Birds Cages roofs</b>	<b>1994</b>	<b>C<sub>03B</sub></b>	<b>0.508</b>	<b>1012.89</b>	<b>0.592</b>	<b>1179.72</b>
5	WS-03C	Grassed	1975	C <sub>03C</sub>	0.300	592.5	0.375	740.63
<b>Overall Area</b>			<b>8261.1</b>					
<b>Sum of (A x C<sub>x###</sub>)</b>						<b>3686.85</b>		<b>4356.79</b>
<b>Average Runoff Coefficients (Post-Development) C<sub>AVGPost</sub></b>						<b>0.446</b>		<b>0.527</b>

**Table 7-5 – Calculations of Peak Runoff (Post-Development)**

No.	Area Name	Area (ha)	Time of Concentration, Tc (min)	Storm: 5 Y			Storm: 100 Y		
				I <sub>5</sub> (mm/hr)	C <sub>AVG5POS</sub>	Q <sub>POST5P</sub> (L/Sec)	I <sub>100</sub> (mm/hr)	C <sub>AVG100POS</sub>	Q <sub>POST100P</sub> (L/Sec)
1	WS-01	0.0078	10	104.288	0.900	2.035	178.559	1.000	3.872
2	WS-02	0.3227	10	104.288	0.531	49.725	178.559	0.616	98.697
3	WS-03A	0.09871	10	104.288	0.300	8.585	178.559	0.375	18.375
4	WS-03B	0.1994	10	104.288	0.508	29.366	178.559	0.592	58.561
5	WS-03C	0.1975	10	104.288	0.300	17.178	178.559	0.375	36.764
<b>Overall Site</b>		<b>0.82611</b>	<b>10</b>	<b>104.288</b>	<b>0.446</b>	<b>106.890</b>	<b>178.559</b>	<b>0.527</b>	<b>216.268</b>

**Notes:**

- 1) Intensity, I = 998.071/(Tc+6.035)<sup>0.814</sup> (5-year, City of Ottawa)
- 2) Intensity, I = 1735.688/(Tc+6.014)<sup>0.820</sup> (100-year, City of Ottawa)
- 3) Cavg for 100-year is increased by 25% over Cavg for 5-year, with a maximum of 1.0.

**Table 7-6 – Calculations of Post-Development increase in Runoff Rate Based on Allowable Runoff**

No.	Area Name	Area (ha)	Time of Concentration, Tc (min)	Storm: 5 Y			Storm: 100 Y			Flow Release			
				I <sub>5</sub> (mm/hr)	C <sub>AVG-POS-5</sub>	Q <sub>POST5</sub> (L/Sec)	I <sub>100</sub> (mm/hr)	C <sub>AVG-POS-100</sub>	Q <sub>POST100</sub> (L/Sec)	Q <sub>PRE5</sub> (L/Sec)	Q <sub>PRE100</sub> (L/Sec)	Q <sub>INC5</sub> (L/Sec)	Q <sub>INC100</sub> (L/Sec)
1	WS-01	0.0078	10	104.288	0.900	2.035	178.55902	1.000	3.872	2.035	3.872	0.000	0.000
2	WS-02	0.3227	10	104.288	0.531	49.725	178.55902	0.616	98.697	28.067	60.070	21.658	38.627
3	WS-03A	0.09871	10	104.288	0.300	8.585	178.55902	0.375	18.375	8.585	18.375	0.000	0.000
	WS-03B	0.1994	10	104.288	0.508	29.366	178.55902	0.592	58.561	17.343	37.118	12.023	21.443
	WS-03C	0.1975	10	104.288	0.300	17.178	178.55902	0.375	36.764	17.178	36.764	0.000	0.000
<b>Overall Site</b>		<b>0.82611</b>	<b>10</b>	<b>104.288</b>	<b>0.446</b>	<b>106.890</b>	<b>178.55902</b>	<b>0.527</b>	<b>216.268</b>	<b>73.209</b>	<b>156.198</b>	<b>33.681</b>	<b>60.070</b>

**Notes:**

- 1) Intensity,  $I = 998.071 / (Tc + 6.035)^{0.814}$  (5-year, City of Ottawa)
- 2) Intensity,  $I = 1735.688 / (Tc + 6.014)^{0.820}$  (100-year, City of Ottawa)
- 3) Cavg for 100-year is increased by 25% over Cavg for 5-year, with a maximum of 1.0.

**Table 7-7 – Storage Volumes for 5-year and 100-year Return Period Storms (Modified Rational Method) for watershed EWS-02**

Duration, T <sub>D</sub> (min)	Release Rate = 28.07 L/Sec Return Period = 5 Years Intensity, I = 998.071/(T <sub>D</sub> +6.035) <sup>0.814</sup> (5-year, City of Ottawa)					Release Rate = 60.07 L/Sec Return Period = 100 Years Intensity: I = 1735.688/(T <sub>D</sub> +6.014) <sup>0.820</sup> (100-year, City of Ottawa)				
	Rainfall Intensity, I (mm/hr)	Peak Flow (L/sec)	Release Rate (L/sec)	Storage Rate (L/sec)	Storage (m <sup>3</sup> )	Rainfall Intensity, I (mm/hr)	Peak Flow (L/sec)	Release Rate (L/sec)	Storage Rate (L/sec)	Storage (m <sup>3</sup> )
0	231.04	110.06	28.07	81.992	0.000	398.62	220.28	60.070	160.214	0.000
<b>10</b>	<b>104.29</b>	<b>49.68</b>	<b>28.07</b>	<b>21.612</b>	<b>12.967</b>	<b>178.56</b>	<b>98.67</b>	<b>60.070</b>	<b>38.605</b>	<b>23.163</b>
15	83.62	39.83	28.07	11.764	10.588	142.89	78.97	60.070	18.896	17.006
20	70.29	33.48	28.07	5.417	6.500	119.95	66.29	60.070	6.217	7.460
30	53.95	25.70	28.07	-2.368	-4.262	91.87	50.77	60.070	-9.302	-16.743
40	44.20	21.05	28.07	-7.013	-16.831	75.15	41.53	60.070	-18.543	-44.504
50	37.66	17.94	28.07	-10.126	-30.378	63.95	35.34	60.070	-24.728	-74.183
60	32.95	15.70	28.07	-12.371	-44.535	55.89	30.89	60.070	-29.182	-105.054
70	29.38	13.99	28.07	-14.073	-59.106	49.79	27.51	60.070	-32.555	-136.732
80	26.57	12.66	28.07	-15.412	-73.977	44.99	24.86	60.070	-35.207	-168.994
90	24.29	11.57	28.07	-16.495	-89.075	41.11	22.72	60.070	-37.351	-201.697
100	22.41	10.68	28.07	-17.392	-104.351	37.90	20.95	60.070	-39.124	-234.744

**Notes:**

- 1 ) Peak flow is equal to the product of 2.78 x C x I x A
- 2 ) I = 998.071/(T<sub>D</sub>+6.035)<sup>0.814</sup> [5-year] I = 1735.688/(T<sub>D</sub>+6.014)<sup>0.820</sup> [100-year] City of Ottawa. From Ottawa Sewer Design Guidelines, Section 5.4.2, where TD = storm duration (mins)
- 3) Release Rate = Desired Capture (Release) Rate
- 4 ) Storage Rate = Peak Flow - Release Rate
- 5) Storage = Duration x Storage Rate = (T<sub>D</sub> (min) X 60) X (Storage Rate (L/sec))/ (1000 L/m<sup>3</sup>) = ### m<sup>3</sup>
- 6) Maximum Storage = Max Storage Over Duration

**Table 7-8 – Storage Volumes for 5-year and 100-year Return Period Storms (Modified Rational Method) for overall watershed EWS-03B**

Duration, T <sub>D</sub> (min)	Release Rate = 17.34 L/Sec Return Period = 5 Years Intensity, I = 998.071/(T <sub>D</sub> +6.035) <sup>0.814</sup> (5-year, City of Ottawa)					Release Rate = 37.118 L/Sec Return Period = 100 Years Intensity: I = 1735.688/(T <sub>D</sub> +6.014) <sup>0.820</sup> (100-year, City of Ottawa)				
	Rainfall Intensity, I (mm/hr)	Peak Flow (L/sec)	Release Rate (L/sec)	Storage Rate (L/sec)	Storage (m <sup>3</sup> )	Rainfall Intensity, I (mm/hr)	Peak Flow (L/sec)	Release Rate (L/sec)	Storage Rate (L/sec)	Storage (m <sup>3</sup> )
0	231.04	65.06	17.34	47.718	0.000	398.62	130.81	37.118	93.695	0.000
<b>10</b>	<b>104.29</b>	<b>29.37</b>	<b>17.34</b>	<b>12.025</b>	<b>7.215</b>	<b>178.56</b>	<b>58.60</b>	<b>37.118</b>	<b>21.479</b>	<b>12.887</b>
15	83.62	23.55	17.34	6.203	5.583	142.89	46.89	37.118	9.775	8.797
20	70.29	19.79	17.34	2.451	2.941	119.95	39.36	37.118	2.245	2.695
30	53.95	15.19	17.34	-2.151	-3.871	91.87	30.15	37.118	-6.970	-12.546
40	44.20	12.45	17.34	-4.897	-11.752	75.15	24.66	37.118	-12.458	-29.899
50	37.66	10.61	17.34	-6.737	-20.211	63.95	20.99	37.118	-16.131	-48.392
60	32.95	9.28	17.34	-8.064	-29.031	55.89	18.34	37.118	-18.775	-67.591
70	29.38	8.27	17.34	-9.070	-38.095	49.79	16.34	37.118	-20.779	-87.271
80	26.57	7.48	17.34	-9.862	-47.337	44.99	14.76	37.118	-22.354	-107.297
90	24.29	6.84	17.34	-10.502	-56.713	41.11	13.49	37.118	-23.627	-127.585
100	22.41	6.31	17.34	-11.032	-66.194	37.90	12.44	37.118	-24.680	-148.077

**Notes:**  
 1 ) Peak flow is equal to the product of 2.78 x C x I x A  
 2) I = 998.071/(T<sub>D</sub>+6.035)<sup>0.814</sup> [5-year] I = 1735.688/(T<sub>D</sub>+6.014)<sup>0.820</sup> [100-year] City of Ottawa. From Ottawa Sewer Design Guidelines, Section 5.4.2, where TD = storm duration (mins)  
 3) Release Rate = Desired Capture (Release) Rate  
 4 ) Storage Rate = Peak Flow - Release Rate  
 5) Storage = Duration x Storage Rate = (T<sub>D</sub> (min) X 60) X (Storage Rate (L/sec))/ (1000 L/m<sup>3</sup>) = ### m<sup>3</sup>  
 6) Maximum Storage = Max Storage Over Duration

**Table 7-9 – Detailed Calculations for the Design of ICDs for EWS-2**

ICD	Watershed	Storm	A (m <sup>2</sup> )	A (mm <sup>2</sup> )	H (m)	Release rate Q (L/Sec)	Release rate Q (m <sup>3</sup> /Sec)	Rectangular		Circular	Cal-Q
								X (mm)	Z (mm)	D	
1	WS-2	100Y	0.0287015	28701.5	0.6	60.07	0.06007	130	220.8	191.2	0.060070266
2	WS-2	5Y	0.014692	14692	0.5	28.07	0.02807	130	113.0	136.8	0.028070184

**Table 7-10 – Detailed Calculations for the Design of ICDs for EWS-3B**

ICD	Watershed	Storm	A (m <sup>2</sup> )	A (mm <sup>2</sup> )	H (m)	Release rate Q (L/Sec)	Release rate Q (m <sup>3</sup> )	Rectangular		Circular	Cal-Q
								X (mm)	Z (mm)	D	
1	WS-3B	100Y	0.0194251	19425.05	0.5	37.113	0.037113	100	194.3	157.3	0.037113036
2	WS-3B	5Y	0.0101646	10164.62	0.4	17.37	0.01737	100	101.6	113.8	0.017370026

## **8. APPENDIX C: STORMCEPTOR SIZING, MAINTENANCE, AND TECHNICAL MANUAL- CANADA**

# ETV Canada Verified



## The Stormceptor® STC

Technology Fact Sheet for Imbrium Systems Inc.

### Performance Claim

The Stormceptor® STC is capable of removing the following pollutants from stormwater runoff when designed in accordance with the PCSWMM for Stormceptor:

- Total Suspended Solids (TSS) overall loading removal range from 76% to 94%
- Total Kjeldahl Nitrogen (TKN) overall loading removal range from 43% to 65%

The TSS claim is based on three overall loading tests performed at three geographically different sites. Site 1 included eight rain events, site 2 had three rain events and site 3 had four rain events. The rain events varied in intensity and duration.

The TKN claim is based on two overall loading tests performed at two geographically different sites. Site 1 included eight rain events and site 3 had four rain events. The rain events varied in intensity and duration.

Simulations produced by the PCSWMM for Stormceptor are based on runoff that is generated from a stabilized catchment with all areas covered by vegetation, concrete, asphalt, structures and/or other non-erodible surfaces.

### Technology Application

The patented Stormceptor® STC is a stormwater quality treatment device that can be installed in place of a conventional maintenance hole in a storm drainage system.

The Stormceptor® STC is a vertically oriented precast concrete cylindrical chamber that is separated into upper and lower compartments by a fiberglass insert.

### Technology Operation

Stormceptor® STC flows into the upper by-pass chamber from the sewer. Inflows less than the design flow rate are diverted by a weir and orifice/drop pipe-assembly through the fiberglass insert into the lower treatment chamber. The drop pipe discharges water parallel to the circular chamber wall to increase detention time and inhibit mixing. From the treatment chamber, water flows up through the riser pipe into the by-pass chamber on the downstream side of the weir and is discharged into the storm sewer.

The water velocity slows when it enters the treatment chamber. Oil or other liquids with a specific gravity less than water will rise and become trapped beneath the fiberglass insert. These pollutants are retained in the treatment chamber because the entrance to the outlet riser pipe is submerged. Sediment will settle to the bottom of the chamber by gravity.

Flows in excess of the orifice/drop pipe capacity will flow over the weir and into the downstream sewer. This action prevents high flows from entering the lower treatment chamber and ensures that captured pollutants are not resuspended.



# Environmental Technology Verification

## Performance Claim Conditions

The conditions for this performance claim are as follows:

### St. Paul, MN, COMO PARK - SITE 1 0.4 ha

	3 Aug 98	7 Aug 98	27 Aug 98	19 Sep 98	23 Sep 98	7 Sep 99	11 Sep 99	19 Sep 99	OVERALL
TSS in, kg	5.22	19.47	1.35	1.42	0.72	0.25	14.59	0.13	43.15
TSS out, kg	1.30	3.61	0.40	1.70	0.89	0.21	2.31	0.03	10.45
<b>TSS removed, kg</b>	<b>3.92</b>	<b>15.86</b>	<b>0.95</b>	<b>-0.28</b>	<b>-0.17</b>	<b>0.04</b>	<b>12.28</b>	<b>0.10</b>	<b>32.70</b>
<b>removal % mass</b>	<b>75</b>	<b>81</b>	<b>70</b>	<b>-19</b>	<b>-24</b>	<b>16</b>	<b>84</b>	<b>77</b>	<b>76</b>
TKN in, kg	0.188	0.141	0.011	0.153	0.011	0.013	0.486	0.002	1.005
TKN out, kg	0.166	0.055	0.012	0.066	0.011	0.001	0.091	0.001	0.345
<b>TKN removed, kg</b>	<b>0.08</b>	<b>0.09</b>	<b>0.00</b>	<b>0.09</b>	<b>0.00</b>	<b>0.01</b>	<b>0.40</b>	<b>0.00</b>	<b>0.66</b>
<b>removal % mass</b>	<b>44</b>	<b>61</b>	<b>-9</b>	<b>57</b>	<b>0</b>	<b>92</b>	<b>81</b>	<b>50</b>	<b>65</b>

### Boston, MA, Westwood - SITE 2 0.3 ha

	5 Aug 97	21 Aug 97	29 Sep 97	OVERALL
TSS in, kg	0.185	0.099	0.120	0.404
TSS out, kg	0.002	0.008	0.013	0.023
<b>TSS removed, kg</b>	<b>0.183</b>	<b>0.091</b>	<b>0.107</b>	<b>0.381</b>
<b>removal % mass</b>	<b>99</b>	<b>92</b>	<b>89</b>	<b>94</b>
TKN in, kg	-	-	-	-
TKN out, kg	-	-	-	-
<b>TKN removed, kg</b>	<b>-</b>	<b>-</b>	<b>-</b>	<b>-</b>
<b>removal % mass</b>	<b>-</b>	<b>-</b>	<b>-</b>	<b>-</b>

### Seattle, WA, Seatac - SITE 3 0.4 ha

	13 Mar 99	25 Apr 99	3 May 99	28 Oct 99	OVERALL
TSS in, kg	1.891	0.699	0.296	7.401	10.287
TSS out, kg	0.658	0.315	0.093	0.308	1.373
<b>TSS removed, kg</b>	<b>1.233</b>	<b>0.384</b>	<b>0.203</b>	<b>7.093</b>	<b>8.914</b>
<b>removal % mass</b>	<b>65</b>	<b>55</b>	<b>69</b>	<b>96</b>	<b>87</b>
TKN in, kg	0.099	0.024	0.028	0.083	0.234
TKN out, kg	0.033	0.024	0.024	0.052	0.133
<b>TKN removed, kg</b>	<b>0.066</b>	<b>0.000</b>	<b>0.004</b>	<b>0.031</b>	<b>0.101</b>
<b>removal % mass</b>	<b>67</b>	<b>0</b>	<b>14</b>	<b>37</b>	<b>43</b>

The performance claim is based on the above data from three field studies conducted at three geographically different locations, comprising fourteen storm events of varying intensity (1 to 131 mm/hr, 1 to 24 hrs duration).

## Verification

Testing was done by the following: Service Environmental & Engineering (St. Paul, MN site); Environmental Sampling Technology (Boston, MA site); Associated Earth Sciences Inc. (Seattle, WA site). The evaluation was conducted by Pollutech Group of Companies Inc. following the Canadian ETV Program's General Verification Protocol (March 2000).

## What is the ETV Program?

The Canadian Environmental Technology Verification (ETV) Program is delivered by The Bloom Centre for Sustainability (BLOOM) under a license agreement from Environment Canada. The Canadian ETV Program is designed to support Canada's environment industry by providing credible and independent verification of technology performance claims.

### Stormceptor® STC Contact Information:

Imbrium Systems Inc.  
2 St Clair Avenue West, Suite 2100  
Toronto, Ontario  
M4V 1L5 Canada  
Tel: (416) 960 9900  
Toll Free: (800) 565 4801  
Fax: (416) 960 5637  
Email: [info@imbriumsystems.com](mailto:info@imbriumsystems.com)  
[www.imbriumsystems.com](http://www.imbriumsystems.com)

### Canadian ETV Program Contact Information:

BLOOM  
2070 Hadwen Road, Suite 101A  
Mississauga, Ontario  
L5K 2C9 Canada  
Tel: (905) 822-4133  
Fax: (905) 822-3558  
E-mail: [melhallak@bloomcentre.com](mailto:melhallak@bloomcentre.com)  
[www.etvcanada.ca](http://www.etvcanada.ca)



## Limitation of Verification

Environment Canada, BLOOM, and the Verification Entity provide the verification services solely on the basis of the information supplied by the applicant or vendor and assume no liability thereafter. The responsibility for the information supplied remains solely with the applicant or vendor and the liability for the purchase, installation, and operation (whether consequential or otherwise) is not transferred to any other party as a result of the verification.

## Stormceptor® EF Sizing Report

### STORMCEPTOR® ESTIMATED NET ANNUAL SEDIMENT (TSS) LOAD REDUCTION

03/31/2022

Province:	Ontario
City:	Ottawa
Nearest Rainfall Station:	OTTAWA CDA RCS
Climate Station Id:	6105978
Years of Rainfall Data:	20

Project Name:	WILD BIRD CARE CENTRE
Project Number:	58134
Designer Name:	Husham Almansour
Designer Company:	ADAD Inc.
Designer Email:	hkhha.adad@gmail.com
Designer Phone:	613-525-1111
EOR Name:	
EOR Company:	
EOR Email:	
EOR Phone:	

Site Name:	
------------	--

Drainage Area (ha):	0.25
Runoff Coefficient 'c':	0.70

Particle Size Distribution:	Fine
Target TSS Removal (%):	80.0

Required Water Quality Runoff Volume Capture (%):	90.00
Estimated Water Quality Flow Rate (L/s):	5.65
Oil / Fuel Spill Risk Site?	Yes
Upstream Flow Control?	No
Peak Conveyance (maximum) Flow Rate (L/s):	44.10
Site Sediment Transport Rate (kg/ha/yr):	

Net Annual Sediment (TSS) Load Reduction Sizing Summary	
Stormceptor Model	TSS Removal Provided (%)
EFO4	94
EFO6	98
EFO8	99
EFO10	100
EFO12	100

**Recommended Stormceptor EFO Model: EFO4**  
**Estimated Net Annual Sediment (TSS) Load Reduction (%): 94**  
**Water Quality Runoff Volume Capture (%): > 90**

## Stormceptor® EF Sizing Report

### THIRD-PARTY TESTING AND VERIFICATION

► **Stormceptor® EF and Stormceptor® EFO** are the latest evolutions in the Stormceptor® oil-grit separator (OGS) technology series, and are designed to remove a wide variety of pollutants from stormwater and snowmelt runoff. These technologies have been third-party tested in accordance with the Canadian ETV **Procedure for Laboratory Testing of Oil-Grit Separators** and performance has been third-party verified in accordance with the **ISO 14034 Environmental Technology Verification (ETV)** protocol.

### PERFORMANCE

► **Stormceptor® EF and EFO** remove stormwater pollutants through gravity separation and floatation, and feature a patent-pending design that generates positive removal of total suspended solids (TSS) throughout each storm event, including high-intensity storms. Captured pollutants include sediment, free oils, and sediment-bound pollutants such as nutrients, heavy metals, and petroleum hydrocarbons. Stormceptor is sized to remove a high level of TSS from the frequent rainfall events that contribute the vast majority of annual runoff volume and pollutant load. The technology incorporates an internal bypass to convey excessive stormwater flows from high-intensity storms through the device without resuspension and washout (scour) of previously captured pollutants. Proper routine maintenance ensures high pollutant removal performance and protection of downstream waterways.

### PARTICLE SIZE DISTRIBUTION (PSD)

► The **Canadian ETV PSD** shown in the table below was used, or in part, for this sizing. This is the identical PSD that is referenced in the Canadian ETV **Procedure for Laboratory Testing of Oil-Grit Separators** for both sediment removal testing and scour testing. The Canadian ETV PSD contains a wide range of particle sizes in the sand and silt fractions, and is considered reasonably representative of the particle size fractions found in typical urban stormwater runoff.

Particle Size (µm)	Percent Less Than	Particle Size Fraction (µm)	Percent
1000	100	500-1000	5
500	95	250-500	5
250	90	150-250	15
150	75	100-150	15
100	60	75-100	10
75	50	50-75	5
50	45	20-50	10
20	35	8-20	15
8	20	5-8	10
5	10	2-5	5
2	5	<2	5

## Stormceptor<sup>®</sup> EF Sizing Report

Rainfall Intensity (mm / hr)	Percent Rainfall Volume (%)	Cumulative Rainfall Volume (%)	Flow Rate (L/s)	Flow Rate (L/min)	Surface Loading Rate (L/min/m <sup>2</sup> )	Removal Efficiency (%)	Incremental Removal (%)	Cumulative Removal (%)
0.5	8.6	8.6	0.24	15.0	12.0	100	8.6	8.6
1	20.3	29.0	0.49	29.0	24.0	100	20.3	29.0
2	16.2	45.2	0.97	58.0	49.0	100	16.2	45.2
3	12.0	57.2	1.46	88.0	73.0	100	12.0	57.2
4	8.4	65.6	1.95	117.0	97.0	97	8.2	65.4
5	5.9	71.6	2.43	146.0	122.0	93	5.6	70.9
6	4.6	76.2	2.92	175.0	146.0	91	4.2	75.1
7	3.1	79.3	3.41	204.0	170.0	87	2.7	77.8
8	2.7	82.0	3.89	234.0	195.0	84	2.3	80.1
9	3.3	85.3	4.38	263.0	219.0	83	2.8	82.9
10	2.3	87.6	4.87	292.0	243.0	81	1.9	84.7
11	1.6	89.2	5.35	321.0	268.0	80	1.3	86.0
12	1.3	90.5	5.84	350.0	292.0	79	1.0	87.0
13	1.7	92.2	6.32	379.0	316.0	78	1.3	88.4
14	1.2	93.5	6.81	409.0	341.0	77	0.9	89.3
15	1.2	94.6	7.30	438.0	365.0	76	0.9	90.2
16	0.7	95.3	7.78	467.0	389.0	74	0.5	90.7
17	0.7	96.1	8.27	496.0	414.0	73	0.5	91.2
18	0.4	96.5	8.76	525.0	438.0	72	0.3	91.5
19	0.4	96.9	9.24	555.0	462.0	71	0.3	91.8
20	0.2	97.1	9.73	584.0	487.0	70	0.2	92.0
21	0.5	97.5	10.22	613.0	511.0	69	0.3	92.3
22	0.2	97.8	10.70	642.0	535.0	68	0.2	92.5
23	1.0	98.8	11.19	671.0	559.0	66	0.7	93.1
24	0.3	99.1	11.68	701.0	584.0	66	0.2	93.3
25	0.0	99.1	12.16	730.0	608.0	65	0.0	93.3
30	0.9	100.0	14.60	876.0	730.0	64	0.6	93.9
35	0.0	100.0	17.03	1022.0	851.0	63	0.0	93.9
40	0.0	100.0	19.46	1168.0	973.0	62	0.0	93.9
45	0.0	100.0	21.89	1314.0	1095.0	59	0.0	93.9
<b>Estimated Net Annual Sediment (TSS) Load Reduction =</b>								<b>94 %</b>

Climate Station ID: 6105978 Years of Rainfall Data: 20



## Stormceptor<sup>®</sup> EF Sizing Report

### RAINFALL DATA FROM OTTAWA CDA RCS RAINFALL STATION

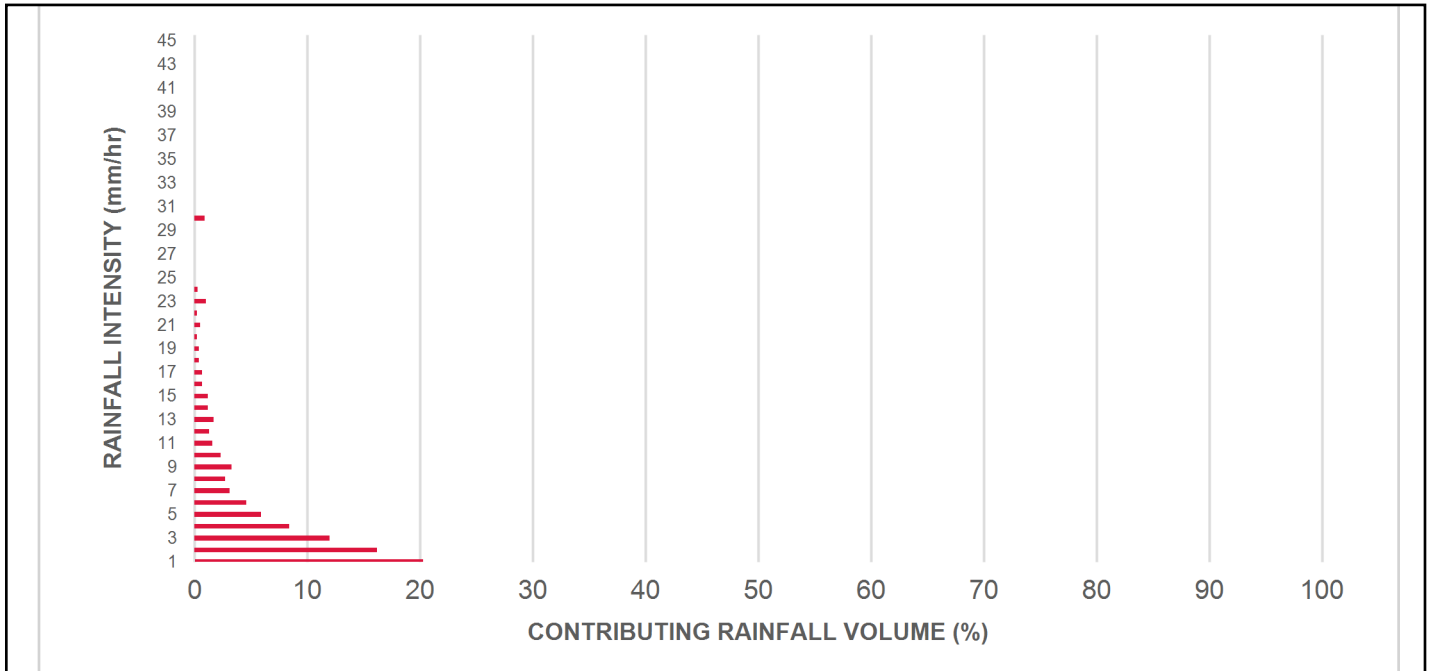

### INCREMENTAL AND CUMULATIVE TSS REMOVAL FOR THE RECOMMENDED STORMCEPTOR<sup>®</sup> MODEL

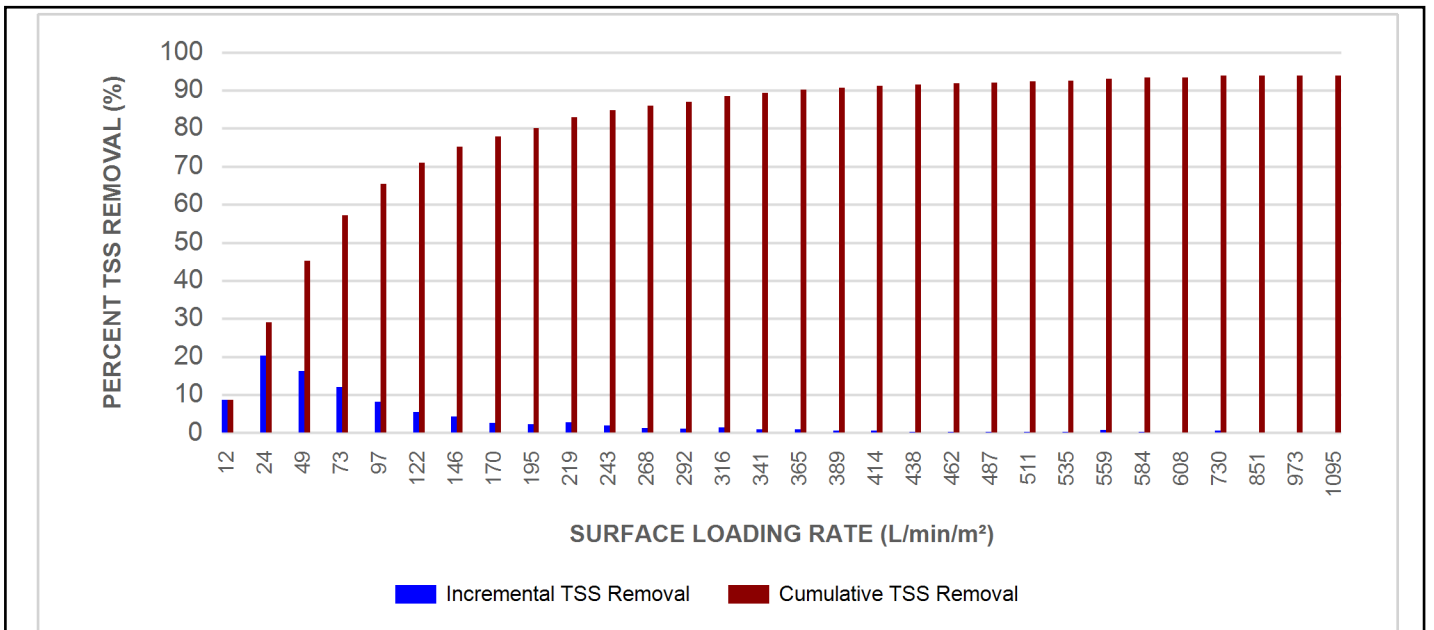

## Stormceptor® EF Sizing Report

### Maximum Pipe Diameter / Peak Conveyance

Stormceptor EF / EFO	Model Diameter		Min Angle Inlet / Outlet Pipes	Max Inlet Pipe Diameter		Max Outlet Pipe Diameter		Peak Conveyance Flow Rate	
	(m)	(ft)		(mm)	(in)	(mm)	(in)	(L/s)	(cfs)
EF4 / EFO4	1.2	4	90	609	24	609	24	425	15
EF6 / EFO6	1.8	6	90	914	36	914	36	990	35
EF8 / EFO8	2.4	8	90	1219	48	1219	48	1700	60
EF10 / EFO10	3.0	10	90	1828	72	1828	72	2830	100
EF12 / EFO12	3.6	12	90	1828	72	1828	72	2830	100

### SCOUR PREVENTION AND ONLINE CONFIGURATION

► Stormceptor® EF and EFO feature an internal bypass and superior scour prevention technology that have been demonstrated in third-party testing according to the scour testing provisions of the Canadian ETV **Procedure for Laboratory Testing of Oil-Grit Separators**, and the exceptional scour test performance has been third-party verified in accordance with the ISO 14034 ETV protocol. As a result, Stormceptor EF and EFO are approved for online installation, eliminating the need for costly additional bypass structures, piping, and installation expense.

### DESIGN FLEXIBILITY

► Stormceptor® EF and EFO offers design flexibility in one simplified platform, accepting stormwater flow from a single inlet pipe or multiple inlet pipes, and/or surface runoff through an inlet grate. The device can also serve as a junction structure, accommodate a 90-degree inlet-to-outlet bend angle, and can be modified to ensure performance in submerged conditions.

### OIL CAPTURE AND RETENTION

► While Stormceptor® EF will capture and retain oil from dry weather spills and low intensity runoff, Stormceptor® EFO has demonstrated superior oil capture and greater than 99% oil retention in third-party testing according to the light liquid re-entrainment testing provisions of the Canadian ETV **Procedure for Laboratory Testing of Oil-Grit Separators**. Stormceptor EFO is recommended for sites where oil capture and retention is a requirement.

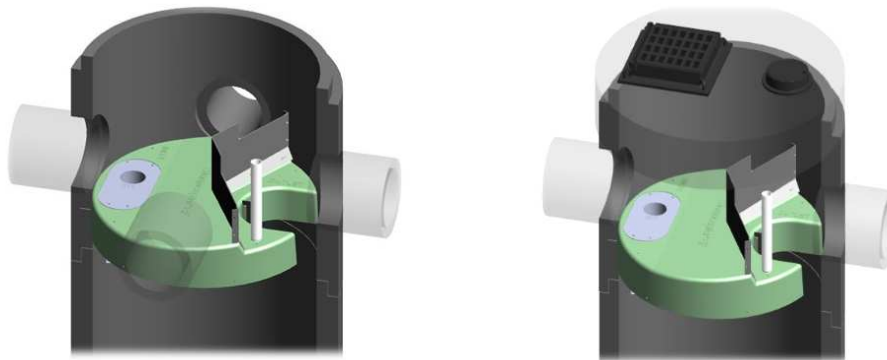

## Stormceptor® EF Sizing Report

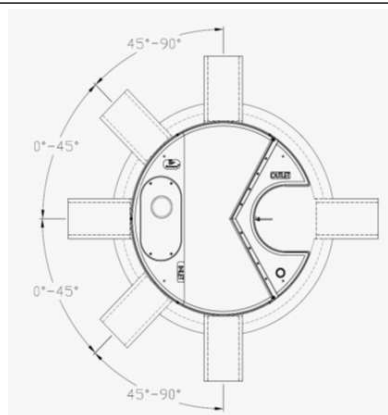

### INLET-TO-OUTLET DROP

Elevation differential between inlet and outlet pipe inverts is dictated by the angle at which the inlet pipe(s) enters the unit.

0° - 45° : The inlet pipe is 1-inch (25mm) higher than the outlet pipe.

45° - 90° : The inlet pipe is 2-inches (50mm) higher than the outlet pipe.

### HEAD LOSS

The head loss through Stormceptor EF is similar to that of a 60-degree bend structure. The applicable K value for calculating minor losses through the unit is 1.1.

For submerged conditions the applicable K value is 3.0.

### Pollutant Capacity

Stormceptor EF / EFO	Model Diameter		Depth (Outlet Pipe Invert to Sump Floor)		Oil Volume		Recommended Sediment Maintenance Depth *		Maximum Sediment Volume *		Maximum Sediment Mass **	
	(m)	(ft)	(m)	(ft)	(L)	(Gal)	(mm)	(in)	(L)	(ft <sup>3</sup> )	(kg)	(lb)
EF4 / EFO4	1.2	4	1.52	5.0	265	70	203	8	1190	42	1904	5250
EF6 / EFO6	1.8	6	1.93	6.3	610	160	305	12	3470	123	5552	15375
EF8 / EFO8	2.4	8	2.59	8.5	1070	280	610	24	8780	310	14048	38750
EF10 / EFO10	3.0	10	3.25	10.7	1670	440	610	24	17790	628	28464	78500
EF12 / EFO12	3.6	12	3.89	12.8	2475	655	610	24	31220	1103	49952	137875

\*Increased sump depth may be added to increase sediment storage capacity

\*\* Average density of wet packed sediment in sump = 1.6 kg/L (100 lb/ft<sup>3</sup>)

Feature	Benefit	Feature Appeals To
Patent-pending enhanced flow treatment and scour prevention technology	Superior, verified third-party performance	Regulator, Specifying & Design Engineer
Third-party verified light liquid capture and retention for EFO version	Proven performance for fuel/oil hotspot locations	Regulator, Specifying & Design Engineer, Site Owner
Functions as bend, junction or inlet structure	Design flexibility	Specifying & Design Engineer
Minimal drop between inlet and outlet	Site installation ease	Contractor
Large diameter outlet riser for inspection and maintenance	Easy maintenance access from grade	Maintenance Contractor & Site Owner

### STANDARD STORMCEPTOR EF/EFO DRAWINGS

For standard details, please visit <http://www.imbriumsystems.com/stormwater-treatment-solutions/stormceptor-ef>

### STANDARD STORMCEPTOR EF/EFO SPECIFICATION

For specifications, please visit <http://www.imbriumsystems.com/stormwater-treatment-solutions/stormceptor-ef>

## Stormceptor<sup>®</sup> EF Sizing Report

### STANDARD PERFORMANCE SPECIFICATION FOR “OIL GRIT SEPARATOR” (OGS) STORMWATER QUALITY TREATMENT DEVICE

#### PART 1 – GENERAL

##### 1.1 WORK INCLUDED

This section specifies requirements for selecting, sizing, and designing an underground Oil Grit Separator (OGS) device for stormwater quality treatment, with third-party testing results and a Statement of Verification in accordance with ISO 14034 Environmental Management – Environmental Technology Verification (ETV).

##### 1.2 REFERENCE STANDARDS & PROCEDURES

ISO 14034:2016 Environmental management – Environmental technology verification (ETV)

Canadian Environmental Technology Verification (ETV) Program’s **Procedure for Laboratory Testing of Oil-Grit Separators**

##### 1.3 SUBMITTALS

1.3.1 All submittals, including sizing reports & shop drawings, shall be submitted upon request with each order to the contractor then forwarded to the Engineer of Record for review and acceptance. Shop drawings shall detail all OGS components, elevations, and sequence of construction.

1.3.2 Alternative devices shall have features identical to or greater than the specified device, including: treatment chamber diameter, treatment chamber wet volume, sediment storage volume, and oil storage volume.

1.3.3 Unless directed otherwise by the Engineer of Record, OGS stormwater quality treatment product substitutions or alternatives submitted within ten days prior to project bid shall not be accepted. All alternatives or substitutions submitted shall be signed and sealed by a local registered Professional Engineer, based on the exact same criteria detailed in Section 3, in entirety, subject to review and approval by the Engineer of Record.

#### PART 2 – PRODUCTS

##### 2.1 OGS POLLUTANT STORAGE

The OGS device shall include a sump for sediment storage, and a protected volume for the capture and storage of petroleum hydrocarbons and buoyant gross pollutants. The minimum sediment & petroleum hydrocarbon storage capacity shall be as follows:

2.1.1	4 ft (1219 mm) Diameter OGS Units:	1.19 m <sup>3</sup> sediment / 265 L oil
	6 ft (1829 mm) Diameter OGS Units:	3.48 m <sup>3</sup> sediment / 609 L oil
	8 ft (2438 mm) Diameter OGS Units:	8.78 m <sup>3</sup> sediment / 1,071 L oil
	10 ft (3048 mm) Diameter OGS Units:	17.78 m <sup>3</sup> sediment / 1,673 L oil
	12 ft (3657 mm) Diameter OGS Units:	31.23 m <sup>3</sup> sediment / 2,476 L oil

#### PART 3 – PERFORMANCE & DESIGN

##### 3.1 GENERAL

The OGS stormwater quality treatment device shall be verified in accordance with ISO 14034:2016 Environmental management – Environmental technology verification (ETV). The OGS stormwater quality treatment device shall



## Stormceptor<sup>®</sup> EF Sizing Report

remove oil, sediment and gross pollutants from stormwater runoff during frequent wet weather events, and retain these pollutants during less frequent high flow wet weather events below the insert within the OGS for later removal during maintenance. The Manufacturer shall have at least ten (10) years of local experience, history and success in engineering design, manufacturing and production and supply of OGS stormwater quality treatment device systems, acceptable to the Engineer of Record.

### 3.2 SIZING METHODOLOGY

The OGS device shall be engineered, designed and sized to provide stormwater quality treatment based on treating a minimum of 90 percent of the average annual runoff volume and a minimum removal of an annual average 60% of the sediment (TSS) load based on the Particle Size Distribution (PSD) specified in the sizing report for the specified device. Sizing of the OGS shall be determined by use of a minimum ten (10) years of local historical rainfall data provided by Environment Canada. Sizing shall also be determined by use of the sediment removal performance data derived from the ISO 14034 ETV third-party verified laboratory testing data from testing conducted in accordance with the Canadian ETV protocol Procedure for Laboratory Testing of Oil-Grit Separators, as follows:

3.2.1 Sediment removal efficiency for a given surface loading rate and its associated flow rate shall be based on sediment removal efficiency demonstrated at the seven (7) tested surface loading rates specified in the protocol, ranging 40 L/min/m<sup>2</sup> to 1400 L/min/m<sup>2</sup>, and as stated in the ISO 14034 ETV Verification Statement for the OGS device.

3.2.2 Sediment removal efficiency for surface loading rates between 40 L/min/m<sup>2</sup> and 1400 L/min/m<sup>2</sup> shall be based on linear interpolation of data between consecutive tested surface loading rates.

3.2.3 Sediment removal efficiency for surface loading rates less than the lowest tested surface loading rate of 40 L/min/m<sup>2</sup> shall be assumed to be identical to the sediment removal efficiency at 40 L/min/m<sup>2</sup>. No extrapolation shall be allowed that results in a sediment removal efficiency that is greater than that demonstrated at 40 L/min/m<sup>2</sup>.

3.2.4 Sediment removal efficiency for surface loading rates greater than the highest tested surface loading rate of 1400 L/min/m<sup>2</sup> shall assume zero sediment removal for the portion of flow that exceeds 1400 L/min/m<sup>2</sup>, and shall be calculated using a simple proportioning formula, with 1400 L/min/m<sup>2</sup> in the numerator and the higher surface loading rate in the denominator, and multiplying the resulting fraction times the sediment removal efficiency at 1400 L/min/m<sup>2</sup>.

The OGS device shall also have sufficient annual sediment storage capacity as specified and calculated in Section 2.1.

### 3.3 CANADIAN ETV or ISO 14034 ETV VERIFICATION OF SCOUR TESTING

The OGS device shall have Canadian ETV or ISO 14034 ETV Verification of third-party scour testing conducted in accordance with the Canadian ETV Program's **Procedure for Laboratory Testing of Oil-Grit Separators**.

3.3.1 To be acceptable for on-line installation, the OGS device must demonstrate an average scour test effluent concentration less than 10 mg/L at each surface loading rate tested, up to and including 2600 L/min/m<sup>2</sup>.

### 3.4 LIGHT LIQUID RE-ENTRAINMENT SIMULATION TESTING

The OGS device shall have Canadian ETV or ISO 14034 ETV Verification of completed third-party Light Liquid Re-entrainment Simulation Testing in accordance with the Canadian ETV **Program's Procedure for Laboratory Testing of Oil-Grit Separators**, with results reported within the Canadian ETV or ISO 14034 ETV verification. This re-entrainment testing is conducted with the device pre-loaded with low density polyethylene (LDPE) plastic beads as a surrogate for light liquids such as oil and fuel. Testing is conducted on the same OGS unit tested for sediment removal to

## Stormceptor<sup>®</sup> EF Sizing Report

assess whether light liquids captured after a spill are effectively retained at high flow rates.

3.4.1 For an OGS device to be an acceptable stormwater treatment device on a site where vehicular traffic occurs and the potential for an oil or fuel spill exists, the OGS device must have reported verified performance results of greater than 99% cumulative retention of LDPE plastic beads for the five specified surface loading rates (ranging 200 L/min/m<sup>2</sup> to 2600 L/min/m<sup>2</sup>) in accordance with the Light Liquid Re-entrainment Simulation Testing within the Canadian ETV Program's **Procedure for Laboratory Testing of Oil-Grit Separators**. However, an OGS device shall not be allowed if the Light Liquid Re-entrainment Simulation Testing was performed with screening components within the OGS device that are effective at retaining the LDPE plastic beads, but would not be expected to retain light liquids such as oil and fuel.

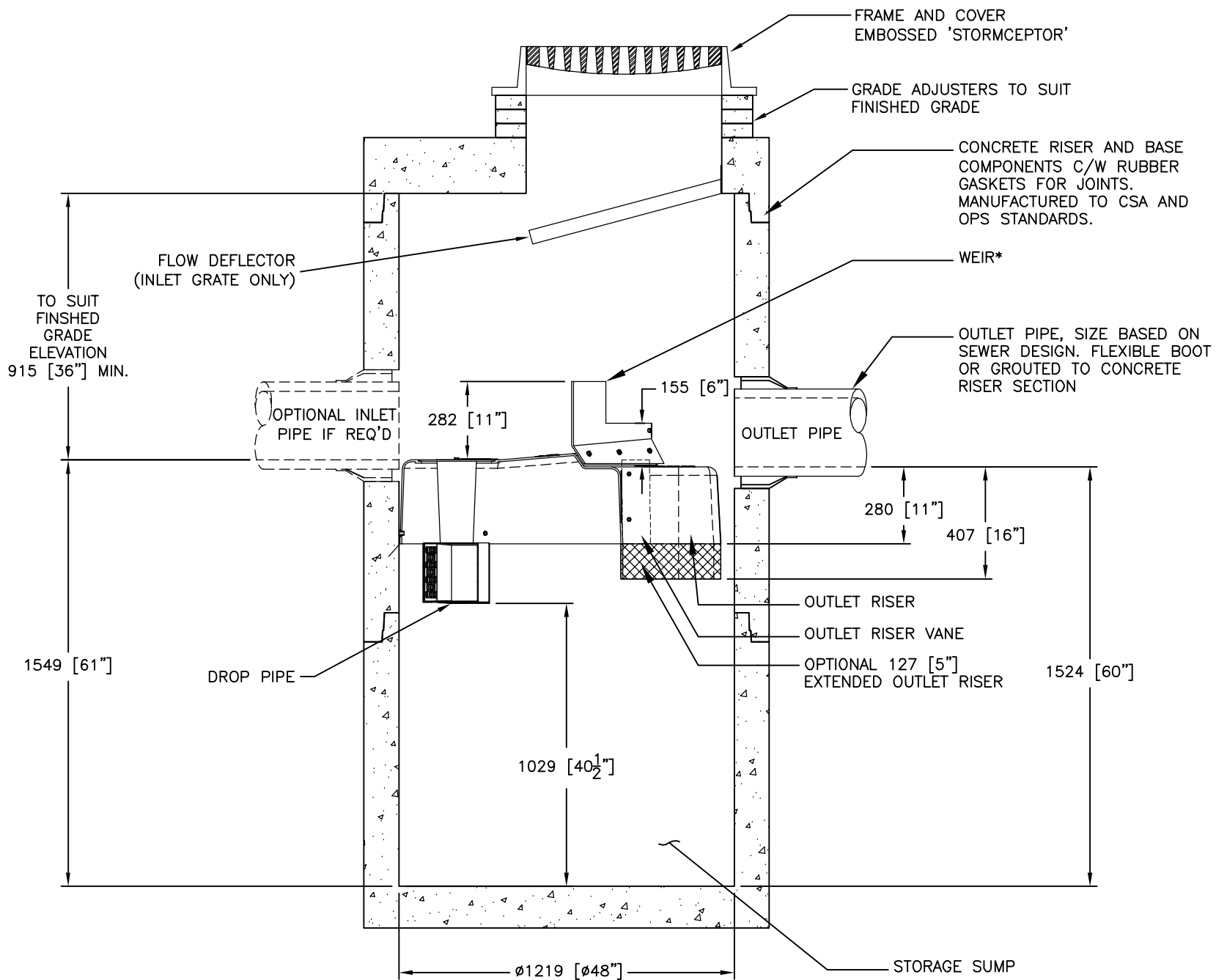

SECTION VIEW

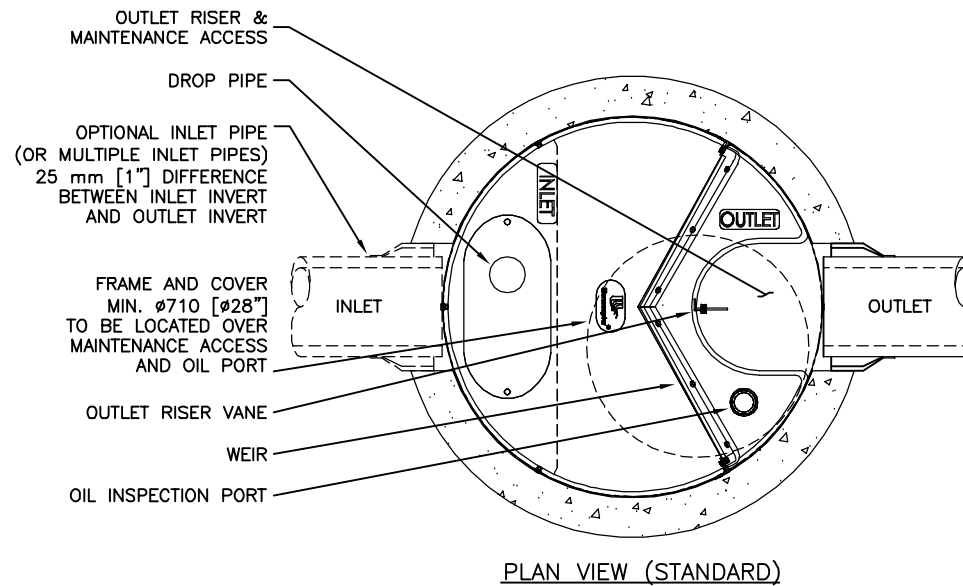

PLAN VIEW (STANDARD)

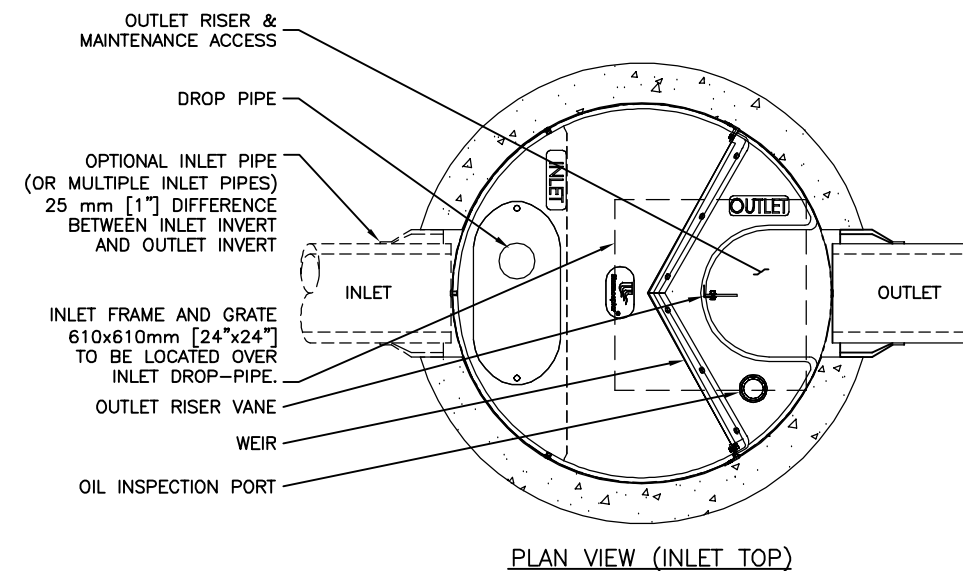

PLAN VIEW (INLET TOP)

FOR SITE SPECIFIC DRAWINGS PLEASE CONTACT YOUR LOCAL STORMCEPTOR REPRESENTATIVE. SITE SPECIFIC DRAWINGS ARE BASED ON THE BEST AVAILABLE INFORMATION AT THE TIME. SOME FIELD REVISIONS TO THE SYSTEM LOCATION OR CONNECTION PIPING MAY BE NECESSARY BASED ON AVAILABLE SPACE OR SITE CONFIGURATION REVISIONS. ELEVATIONS SHOULD BE MAINTAINED EXCEPT WHERE NOTED ON BYPASS STRUCTURE (IF REQUIRED).

**GENERAL NOTES:**

- \* MAXIMUM SURFACE LOADING RATE (SLR) INTO LOWER CHAMBER THROUGH DROP PIPE IS 1135 L/min/m<sup>2</sup> (27.9 gpm/ft<sup>2</sup>) FOR STORMCEPTOR EF4 AND 535 L/min/m<sup>2</sup> (13.1 gpm/ft<sup>2</sup>) FOR STORMCEPTOR EFO4 (OIL CAPTURE CONFIGURATION). WEIR HEIGHT IS 150 mm (6 INCH) FOR EF04.
- 1. ALL DIMENSIONS INDICATED ARE IN MILLIMETERS (INCHES) UNLESS OTHERWISE SPECIFIED.
- 2. STORMCEPTOR STRUCTURE INLET AND OUTLET PIPE SIZE AND ORIENTATION SHOWN FOR INFORMATIONAL PURPOSES ONLY.
- 3. UNLESS OTHERWISE NOTED, BYPASS INFRASTRUCTURE, SUCH AS ALL UPSTREAM DIVERSION STRUCTURES, CONNECTING STRUCTURES, OR PIPE CONDUITS CONNECTING TO COMPLETE THE STORMCEPTOR SYSTEM SHALL BE PROVIDED AND ADDRESSED SEPARATELY.
- 4. DRAWING FOR INFORMATIONAL PURPOSES ONLY. REFER TO ENGINEER'S SITE/UTILITY PLAN FOR STRUCTURE ORIENTATION.
- 5. NO PRODUCT SUBSTITUTIONS SHALL BE ACCEPTED UNLESS SUBMITTED 10 DAYS PRIOR TO PROJECT BID DATE, OR AS DIRECTED BY THE ENGINEER OF RECORD.

**INSTALLATION NOTES**

- A. ANY SUB-BASE, BACKFILL DEPTH, AND/OR ANTI-FLOTATION PROVISIONS ARE SITE-SPECIFIC DESIGN CONSIDERATIONS AND SHALL BE SPECIFIED BY ENGINEER OF RECORD.
- B. CONTRACTOR TO PROVIDE EQUIPMENT WITH SUFFICIENT LIFTING AND REACH CAPACITY TO LIFT AND SET THE STRUCTURE (LIFTING CLUTCHES PROVIDED)
- C. CONTRACTOR WILL INSTALL AND LEVEL THE STRUCTURE, SEALING THE JOINTS, LINE ENTRY AND EXIT POINTS (NON-SHRINK GROUT WITH APPROVED WATERSTOP OR FLEXIBLE BOOT)
- D. CONTRACTOR TO TAKE APPROPRIATE MEASURES TO PROTECT THE DEVICE FROM CONSTRUCTION-RELATED EROSION RUNOFF.
- E. DEVICE ACTIVATION, BY CONTRACTOR, SHALL OCCUR ONLY AFTER SITE HAS BEEN STABILIZED AND THE STORMCEPTOR UNIT IS CLEAN AND FREE OF DEBRIS.

**STANDARD DETAIL  
NOT FOR CONSTRUCTION**

**SITE SPECIFIC DATA REQUIREMENTS**

PIPE DATA:	I.E.	MAT'L	DIA	SLOPE %	HGL
INLET #1	*	*	*	*	*
INLET #2	*	*	*	*	*
OUTLET	*	*	*	*	*

\* PER ENGINEER OF RECORD

This design and information shall be the property of Imbrium Systems ("Imbrium") and shall be provided as a service to the project owner, engineer and contractor by Imbrium Systems ("Imbrium"). Neither the drawing, nor any part thereof, may be reproduced, stored in a retrieval system, or transmitted in any form or by any means, electronic, mechanical, photocopying, recording, or by any information storage and retrieval system, without the prior written consent of Imbrium. Failure to comply with the above conditions shall constitute a breach of the license and Imbrium expressly disclaims any liability or responsibility for such use. If discrepancies between the supplied information upon which the drawing is based and actual field conditions are identified, the contractor shall immediately discontinue use of the design. Imbrium accepts no liability for design based on missing, incomplete or inaccurate information supplied by others.

DATE	MARK	REVISION DESCRIPTION	BY
6/8/18	1	UPDATES	JSK
5/26/17	0	INITIAL RELEASE	JSK

**Stormceptor® EF**

**imbrium**

407 FAIRVIEW DRIVE, WHITBY, ON L1N 3J9  
 TEL: 905-885-4801 CA: 416-960-9900 INTL: +1-416-960-9900

THE ENGINEER/OWNER/INSTALLER SHALL BE RESPONSIBLE FOR THE CORRECTNESS OF THE INFORMATION PROVIDED HEREON. IMBRIUM SYSTEMS SHALL NOT BE RESPONSIBLE FOR THE CORRECTNESS OF THE INFORMATION PROVIDED HEREON. IMBRIUM SYSTEMS SHALL NOT BE RESPONSIBLE FOR THE CORRECTNESS OF THE INFORMATION PROVIDED HEREON.

DATE: 10/13/2017

DESIGNED: JSK  
 CHECKED: BSF  
 PROJECT No.: EFO4  
 SHEET: 1 OF 1

SCALE = NTS

# STANDARD SPECIFICATION FOR “OIL GRIT SEPARATOR” (OGS) STORMWATER QUALITY TREATMENT DEVICE WITH THIRD-PARTY VERIFIED LIGHT LIQUID RE-ENTRAINMENT SIMULATION PERFORMANCE TESTING RESULTS

## PART 1 – GENERAL

### 1.1 WORK INCLUDED

This section specifies requirements for selecting, sizing, designing, maintaining, and constructing an underground Oil Grit Separator (OGS) device for stormwater quality treatment, **specifically an OGS device that has been third-party tested for oil and fuel retention capability using a protocol for light liquid re-entrainment simulation testing, with t testing results and a Statement of Verification in accordance with all the provisions of ISO 14034 Environmental Management – Environmental Technology Verification (ETV)**. Work includes supply and installation of concrete bases, precast sections, and the appropriate precast section with OGS internal components correctly installed within the system, watertight sealed to the precast concrete prior to arrival to the project site.

### 1.2 REFERENCE STANDARDS

#### 1.2.1 For Canadian projects only, the following reference standards apply:

CAN/CSA-A257.4-14: Joints for Circular Concrete Sewer and Culvert Pipe, Manhole Sections, and Fittings Using Rubber Gaskets

CAN/CSA-A257.4-14: Precast Reinforced Circular Concrete Manhole Sections, Catch Basins, and Fittings

CAN/CSA-S6-00: Canadian Highway Bridge Design Code

#### 1.2.2 For ALL projects, the following reference standards apply:

ASTM D-4097: Contact Molded Glass Fiber Reinforced Chemical Resistant Tanks

ASTM C 478: Specification for Precast Reinforced Concrete Manhole Sections

ASTM C 443: Specification for Joints for Concrete Pipe and Manholes, Using Rubber Gaskets

ASTM C 891: Standard Practice for Installation of Underground Precast Concrete Utility Structures

ASTM D2563: Standard Practice for Classification of Visual Defects in Reinforced Plastics

### 1.3 SHOP DRAWINGS

1.3.1 Shop drawings shall be submitted upon request with each order to the contractor then forwarded to the Engineer of Record for review and acceptance. Shop drawings shall detail the precast concrete components and OGS internal components prior to shipment, including the sequence for installation.

1.3.2 Unless directed otherwise by the Engineer of Record, OGS stormwater quality treatment product substitutions or alternatives submitted within ten days prior to project bid shall not be accepted. All alternatives or substitutions submitted shall be based on the exact same criteria detailed in Section 3, in entirety, subject to review and approval by the Engineer of Record. Any and all changes to project cost estimates, bonding amounts, plan check fees for revision of approved documents, or design impacts due to regulatory requirements as a result of a product substitution shall be coordinated by the Contractor with the Engineer of Record.

### 1.4 HANDLING AND STORAGE

Prevent damage to materials during storage and handling.

1.4.1 OGS internal components supplied by the Manufacturer for attachment to the precast concrete vessel shall be pre-fabricated, bolted to the precast and watertight sealed to the precast vessel surface prior to site delivery to ensure Manufacturer's internal assembly process and quality control processes are fully adhered to, and to prevent materials damage on site.

1.4.2 Follow all instructions including the sequence for installation in the shop drawings during installation.

## **PART 2 – PRODUCTS**

### **2.1 GENERAL**

2.1.1 The OGS vessel shall be cylindrical and constructed from precast concrete riser and slab components.

2.1.2 The precast concrete OGS internal components shall include a fiberglass insert bolted and watertight sealed inside the precast concrete vessel, prior to site delivery. Primary internal components that are to be anchored and watertight sealed to the precast concrete vessel shall be done so only by the Manufacturer prior to arrival at the job site to ensure product quality.

2.1.3 The OGS shall be allowed to be specified and have the ability to function as a 240-degree bend structure in the stormwater drainage system, or as a junction structure.

2.1.4 The OGS to be specified shall have the capability to accept influent flow from an inlet grate and an inlet pipe.

### **2.2 PRECAST CONCRETE SECTIONS**

All precast concrete components shall be designed and manufactured to meet highway loading conditions per State/Provincial or local requirements.

### **2.3 GASKETS**

Only profile neoprene or nitrile rubber gaskets that are oil resistant shall be accepted. For Canadian projects only, gaskets shall be in accordance to CSA A257.4-14. Mastic sealants, butyl tape/rope or Conseal CS-101 alone are not acceptable gasket materials.

### **2.4 JOINTS**

The concrete joints shall be watertight and meet the design criteria according to ASTM C-990. For projects where joints require gaskets, the concrete joints shall be watertight and oil resistant and meet the design criteria according to ASTM C-443. Mastic sealants or butyl tape/rope alone are not an acceptable alternative.

### **2.5 FRAMES AND COVERS**

Frames and covers shall be manufactured in accordance with State/Provincial or local requirements for inspection and maintenance access purposes. A minimum of one cover, at least 22-inch (560 mm) in diameter, shall be clearly embossed with the OGS manufacturer's product name to properly identify this asset's purpose is for stormwater quality treatment.

### **2.6 PRECAST CONCRETE**

All precast concrete components shall conform to the appropriate CSA or ASTM specifications.

### **2.7 FIBERGLASS**

The fiberglass portion of the OGS device shall be constructed in accordance with ASTM D2563, and in accordance with the PS15-69 manufacturing standard, and shall only be installed, bolted and watertight sealed to the precast concrete by the Manufacturer prior to arrival at the project site to ensure product quality.

## 2.8 OGS POLLUTANT STORAGE

The OGS device shall include a sump for sediment storage, and a fiberglass insert for the capture and storage of petroleum hydrocarbons and buoyant gross pollutants. The total sediment storage capacity shall be a minimum 40 ft<sup>3</sup> (1.1 m<sup>3</sup>). The total petroleum hydrocarbon storage capacity shall be a minimum 50 gallons (189 liters). The access opening to the sump of the OGS device for periodic inspection and maintenance purposes shall be a minimum 16 inches (406 mm) in diameter.

## 2.9 LADDERS

Ladder rungs shall be provided upon request or to comply with State/Provincial or local requirements.

## 2.10 INSPECTION

All precast concrete sections shall be level and inspected to ensure dimensions, appearance, integrity of internal components, and quality of the product meets State/Provincial or local specifications and associated standards.

# **PART 3 – PERFORMANCE & DESIGN**

## 3.1 GENERAL

The OGS stormwater quality treatment device shall be verified in accordance with ISO 14034:2016 Environmental management – Environmental technology verification (ETV). The OGS stormwater quality treatment device shall remove oil, sediment and gross pollutants from stormwater runoff during frequent wet weather events, and retain these pollutants during less frequent high flow wet weather events below the insert within the OGS for later removal during maintenance. The Manufacturer shall have at least ten (10) years of local experience, history and success in engineering design, manufacturing and production and supply of OGS stormwater quality treatment device systems, acceptable to the Engineer of Record.

## 3.2 HYDROLOGY AND RUNOFF VOLUME

The OGS device shall be engineered, designed and sized to treat a minimum of 90 percent of the average annual runoff volume, unless otherwise stated by the Engineer of Record, using historical rainfall data. Rainfall data sets should be comprised of a minimum 15-years of rainfall data or a longer continuous period if available for a given location, but in all cases a minimum 5-year period of rainfall data.

## 3.3 ANNUAL (TSS) SEDIMENT LOAD AND STORAGE CAPACITY

The OGS device shall be capable of removing and have sufficient storage capacity for the calculated annual total suspended solids (TSS) mass load and volume without scouring previously captured pollutants prior to maintenance being required. The annual (TSS) sediment load and volume transported from the drainage area should be calculated and compared to the OGS device's available storage capacity by the specifying Engineer to ensure adequate capacity between maintenance cycles. Sediment loadings shall be determined by land use and defined as a minimum of 450 kg (992 lb) of sediment (TSS) per impervious hectare of drainage area per year, or greater based on land use, as noted in Table 1 below.

Annual sediment volume calculations shall be performed using the projected average annual treated runoff volume, a typical sediment bulk density of 1602 kg/m<sup>3</sup> (100 lbs/ft<sup>3</sup>) and an assumed Event Mean

Concentration (EMC) of 125 mg/L TSS in the runoff, or as otherwise determined by the Engineer of Record.

Example calculation for a 1.3-hectares parking lot site:

- 1.28 meters of rainfall depth, per year
- 1.3 hectares of 100% impervious drainage area
- EMC of 125 mg/L TSS in runoff
- Treatment of 90% of the average annual runoff volume
- Target average annual TSS removal rate of 60% by OGS

Annual Runoff Volume:

- 1.28 m rain depth x 1.3 ha x 10,000 m<sup>2</sup>/ha= 16,640 m<sup>3</sup> of runoff volume
- 16,640 m<sup>3</sup> x 1000 L/m<sup>3</sup> = 16,640,000 L of runoff volume
- 16,640,000 L x 0.90 = 14,976,000 L to be treated by OGS unit

Annual Sediment Mass and Sediment Volume Load Calculation:

- 14,976,000 L x 125 mg/L x kg/1,000,000 mg = 1,872 kg annual sediment mass
- 1,872 kg x m<sup>3</sup>/1602 kg = 1.17 m<sup>3</sup> annual sediment volume
- 1.17 m<sup>3</sup> x 60% TSS removal rate by OGS = 0.70 m<sup>3</sup> minimum expected annual storage requirement in OGS

As a guideline, the U.S. EPA has determined typical annual sediment loads per drainage area for various sites by land use (see Table 1). Certain States, Provinces and local jurisdictions have also established such guidelines.

Table 1 – Annual Mass Sediment Loading by Land Use								
	Commercial	Parking Lot	Residential			Highways	Industrial	Shopping Center
			High	Med.	Low			
(lbs/acre/yr)	1,000	400	420	250	10	880	500	440
(kg/hectare/yr)	1,124	450	472	281	11	989	562	494

Source: U.S. EPA Stormwater Best Management Practice Design Guide Volume 1, Appendix D, Table D-1, Burton and Pitt 2002

### 3.4 SIZING METHODOLOGY

The OGS device shall be engineered, designed and sized to provide stormwater quality treatment based on treating a minimum of 90 percent of the average annual runoff volume and a minimum removal of an annual average 60% of the sediment (TSS) load based on the Particle Size Distribution (PSD) specified in Table 2, Section 3.5, and based on third-party performance testing conducted in accordance with the Canadian Environmental Technology Verification (ETV) Program's **Procedure for Laboratory Testing of Oil-Grit Separators**. Sizing shall be determined using historical rainfall data (as specified in Section 3.2) and a sediment removal performance curve derived from the actual third-party verified laboratory testing data. The OGS device shall also have sufficient annual sediment storage capacity as specified and calculated in Section 3.3.

3.4.1 The Peclet Number is not an approved method or model for calculating TSS removal, sizing, or scaling OGS devices.

3.4.2 If an alternate OGS device is proposed, supporting documentation shall be submitted that demonstrates:

- Canadian ETV or ISO 14034 ETV Verification Statement which verifies third-party performance testing conducted in accordance with the **Procedure for Laboratory Testing of Oil-Grit Separators**, including the Light Liquid Re-entrainment Simulation Testing.
- Equal or better sediment (TSS) removal of the PSD specified in Table 2 at equivalent surface loading rates, as compared to the OGS device specified herein.
- Equal or better Light Liquid Re-entrainment Simulation Test results (using low-density polyethylene beads as a surrogate for light liquids such as oil and fuel) at equivalent

surface loading rates, as compared to the OGS device specified herein. However, an alternative OGS device shall not be allowed as a substitute if the Light Liquid Re-entrainment Simulation Test was performed with screening components within the OGS device that are effective at retaining the low-density polyethylene beads, but would not be expected to retain light liquids such as oil and fuel.

- Equal or greater sediment storage capacity, as compared to the OGS device specified herein.
- Supporting documentation shall be signed and sealed by a local registered Professional Engineer. All costs associated with preparing and certifying this documentation shall be born solely by the Contractor.

### 3.5 PARTICLE SIZE DISTRIBUTION (PSD) FOR SIZING

The OGS device shall be sized to achieve the Engineer-specified average annual percent sediment (TSS) removal based solely on the test sediment used in the Canadian ETV Program's **Procedure for Laboratory Testing of Oil-Grit Separators**. This test sediment is comprised of inorganic ground silica with a specific gravity of 2.65, uniformly mixed, and containing a broad range of particle sizes as specified in Table 2. No alternative PSDs or deviations from Table 2 shall be accepted.

<b>Table 2</b> <b>Canadian ETV Program Procedure for Laboratory</b> <b>Testing of Oil-Grit Separators</b> <b>Particle Size Distribution (PSD) of Test Sediment</b>		
Particle Diameter (Microns)	% by Mass of All Particles	Specific Gravity
1000	5%	2.65
500	5%	2.65
250	15%	2.65
150	15%	2.65
100	10%	2.65
75	5%	2.65
50	10%	2.65
20	15%	2.65
8	10%	2.65
5	5%	2.65
2	5%	2.65

### 3.6 CANADIAN ETV or ISO 14034 ETV VERIFICATION OF SCOUR TESTING

The OGS device shall have Canadian ETV or ISO 14034 ETV Verification of completed third-party scour testing conducted and have in accordance with the Canadian ETV Program's **Procedure for Laboratory Testing of Oil-Grit Separators**. This scour testing is conducted with the device pre-loaded with test sediment comprised of the particle size distribution (PSD) illustrated in Table 2.

3.6.1 To be acceptable for on-line installation, the OGS device must demonstrate an average scour test effluent concentration less than 10 mg/L at each surface loading rate tested, up to and including 2600 L/min/m<sup>2</sup>.

Data generated from laboratory scour testing performed with an OGS device pre-loaded with a coarser PSD than in Table 2 (i.e. the coarser PSD has no particles in the 1-micron to 50-micron size range, or the D<sub>50</sub> of the test sediment exceeds 75 microns) shall not be acceptable for the determination of the device's suitability for on-line installation.

### 3.7 DESIGN ACCOUNTING FOR BYPASS

3.7.1 The OGS device shall be specified to achieve the TSS removal performance and water quality objectives without washout of previously captured pollutants. The OGS device shall also have sufficient hydraulic conveyance capacity to convey the peak storm event, in accordance



with hydraulic conditions per the Engineer of Record. To ensure this is achieved, there are two design options with associated requirements:

3.7.1.1 The OGS device shall be placed **off-line** with an upstream diversion structure (typically in an upstream manhole) that only allows the water quality volume to be diverted to the OGS device, and excessive flows diverted downstream around the OGS device to prevent high flow washout of pollutants previously captured. This design typically incorporates a triangular layout including an upstream bypass manhole with an appropriately engineered weir wall, the OGS device, and a downstream junction manhole, which is connected to both the OGS device and bypass structure. In this case with an external bypass required, the OGS device manufacturer must provide calculations and designs for all structures, piping and any other required material applicable to the proper functioning of the system, stamped by a Professional Engineer.

3.7.1.2 Alternatively, OGS devices in compliance with Section 3.6 shall be acceptable for an **on-line** design configuration, thereby eliminating the requirement for an upstream bypass manhole and downstream junction manhole.

3.7.2 The OGS device shall also have sufficient hydraulic conveyance capacity to convey the peak storm event, in accordance with hydraulic conditions per the Engineer of Record. If an alternate OGS device is proposed, supporting documentation shall be submitted that demonstrates equal or better hydraulic conveyance capacity as compared to the OGS device specified herein. This documentation shall be signed and sealed by a local registered Professional Engineer. All costs associated with preparing and certifying this documentation shall be born solely by the Contractor.

### 3.8 LIGHT LIQUID RE-ENTRAINMENT SIMULATION TESTING

The OGS device shall have Canadian ETV or ISO 14034 ETV Verification of completed third-party Light Liquid Re-entrainment Simulation Testing in accordance with the Canadian ETV Program's **Procedure for Laboratory Testing of Oil-Grit Separators**, with results reported within the Canadian ETV or ISO 14034 ETV verification. This re-entrainment testing is conducted with the device pre-loaded with low density polyethylene (LDPE) plastic beads as a surrogate for light liquids such as oil and fuel. Testing is conducted on the same OGS unit tested for sediment removal to assess whether light liquids captured after a spill are effectively retained at high flow rates.

3.8.1 For an OGS device to be an acceptable stormwater treatment device on a site where vehicular traffic occurs and the potential for an oil or fuel spill exists, the OGS device must have reported verified performance results of greater than 99% cumulative retention of LDPE plastic beads for the five specified surface loading rates (ranging 200 L/min/m<sup>2</sup> to 2600 L/min/m<sup>2</sup>) in accordance with the Light Liquid Re-entrainment Simulation Testing within the Canadian ETV Program's **Procedure for Laboratory Testing of Oil-Grit Separators**. However, an OGS device shall not be allowed if the Light Liquid Re-entrainment Simulation Testing was performed with screening components within the OGS device that are effective at retaining the LDPE plastic beads, but would not be expected to retain light liquids such as oil and fuel.

### 3.9 PETROLEUM HYDROCARBONS AND FLOATABLES STORAGE CAPACITY

Petroleum hydrocarbons and floatables storage capacity in the OGS device shall be a minimum 50 gallons (189 Liters), or more as specified.

3.9.1 The OGS device shall have gasketed precast concrete joints that are watertight, and oil resistant and meet the design criteria according to ASTM C-443 to provide safe oil and other hydrocarbon materials storage and ground water protection. Mastic sealants or butyl tape/rope alone are not an acceptable alternative.

### 3.10 SURFACE LOADING RATE SCALING OF DIFFERENT MODEL SIZES

The reference device for scaling shall be an OGS device that has been third-party tested in accordance with the Canadian ETV Program's **Procedure for Laboratory Testing of Oil-Grit Separators**. Other model sizes of the tested device shall only be scaled such that the claimed TSS removal efficiency of the scaled device shall be no greater than the TSS removal efficiency of the tested device at identical **surface loading rates** (flow rate divided by settling surface area). The depth of other model sizes of the tested device shall be scaled in accordance with the depth scaling provisions within Section 6.0 of the Canadian ETV Program's **Procedure for Laboratory Testing of Oil-Grit Separators**.

3.10.1 The Peclet Number and volumetric scaling are not approved methods for scaling OGS devices.

## **PART 4 – INSPECTION & MAINTENANCE**

The OGS manufacturer shall provide an Owner's Manual upon request.

- 4.1 A Quality Assurance Plan that provides inspection and maintenance for a minimum of 5 years shall be included with the OGS stormwater quality device, and written into the Environmental Compliance Approval (ECA) or the appropriate State/Provincial or local approval document.
- 4.2 OGS device inspection shall include determination of sediment depth and presence of petroleum hydrocarbons and floatables below the insert. Inspection shall be easily conducted from finished grade through a Frame and Cover of at least 22 inch (560 mm) in diameter.
- 4.3 Inspection and pollutant removal from below the OGS's insert shall be conducted as a periodic maintenance practice using a standard maintenance truck and vacuum apparatus, and shall be easily conducted from finished grade through a Frame and Cover of at least 22-inches (560 mm) in diameter, and through an access opening to the OGS device's sump with a minimum 16-inches diameter (406 mm).
- 4.4 No confined space for sediment removal or inspection of internal components shall be required for normal operation, annual inspection or maintenance activity.

## **PART 5 – EXECUTION**

### **5.1 PRECAST CONCRETE INSTALLATION**

The installation of the precast concrete OGS stormwater quality treatment device shall conform to ASTM C 891, ASTM C 478, ASTM C 443, CAN/CSA-A257.4-14, CAN/CSA-A257.4-14, CAN/CSA-S6-00 and all highway, State/Provincial, or local specifications for the construction of manholes. Selected sections of a general specification that are applicable are summarized below. The Contractor shall furnish all labor, equipment and materials necessary to offload, assemble as needed the OGS internal components as specified in the Shop Drawings.

### **5.2 EXCAVATION**

5.2.1 Excavation for the installation of the OGS stormwater quality treatment device shall conform to highway, State/Provincial or local specifications. Topsoil that is removed during the excavation for the OGS stormwater quality treatment device shall be stockpiled in designated areas and not be mixed with subsoil or other materials. Topsoil stockpiles and the general site preparation for the installation of the OGS stormwater quality device shall conform to highway, State/Provincial or local specifications.

5.2.2 The OGS device shall not be installed on frozen ground. Excavation shall extend a minimum of 12 inch (300 mm) from the precast concrete surfaces plus an allowance for shoring and bracing where required. If the bottom of the excavation provides an unsuitable foundation additional excavation may be required.

5.2.3 In areas with a high water table, continuous dewatering shall be provided to ensure that the excavation is stable and free of water.

### 5.3 BACKFILLING

Backfill material shall conform to highway, State/Provincial or local specifications. Backfill material shall be placed in uniform layers not exceeding 12 inches (300 mm) in depth and compacted to highway, State/Provincial or local specifications.

### 5.4 OGS WATER QUALITY DEVICE CONSTRUCTION SEQUENCE

5.4.1 The precast concrete OGS stormwater quality treatment device is installed and leveled in sections in the following sequence:

- aggregate base
- base slab, or base
- riser section(s) (if required)
- riser section w/ pre-installed fiberglass insert
- upper riser section(s)
- internal OGS device components
- connect inlet and outlet pipes
- riser section, top slab and/or transition (if required)
- frame and access cover

5.4.2 The precast concrete base shall be placed level at the specified grade. The entire base shall be in contact with the underlying compacted granular material. Subsequent sections, complete with oil resistant, watertight joint seals, shall be installed in accordance with the precast concrete manufacturer's recommendations.

5.4.3 Adjustment of the OGS stormwater quality treatment device can be performed by lifting the upper sections free of the excavated area, re-leveling the base, and re-installing the sections. Damaged sections and gaskets shall be repaired or replaced as necessary. Once the OGS stormwater quality treatment device has been constructed, any lift holes must be plugged with mortar.

### 5.5 DROP PIPE AND OIL INSPECTION PIPE

Once the upper precast concrete riser has been attached to the lower precast concrete riser section, the OGS device Drop Pipe and Oil Inspection Pipe must be attached, and watertight sealed to the fiberglass insert using Sikaflex 1a. Installation instructions and required materials shall be provided by the OGS manufacturer.

### 5.6 INLET AND OUTLET PIPES

Inlet and outlet pipes shall be securely set using grout or approved pipe seals (flexible boot connections, where applicable) so that the structure is watertight. Non-secure inlets and outlets will result in improper performance.

### 5.7 FRAME AND COVER OR FRAME AND GRATE INSTALLATION

Precast concrete adjustment units shall be installed to set the frame and cover/grate at the required elevation. The adjustment units shall be laid in a full bed of mortar with successive units being joined using sealant recommended by the manufacturer. Frames for the cover/grate should be set in a full bed of mortar at the elevation specified.

5.7.1 A minimum of one cover, at least 22-inch (560 mm) in diameter, shall be clearly embossed with the OGS device brand or product name to properly identify this asset's purpose is for stormwater quality treatment.

# VERIFICATION STATEMENT

## GLOBE Performance Solutions

Verifies the performance of

### Stormceptor® EF4 and EFO4 Oil-Grit Separators

Developed by Imbrium Systems, Inc.,  
Whitby, Ontario, Canada

In accordance with

## ISO 14034:2016

**Environmental management —  
Environmental technology verification (ETV)**



John D. Wiebe, PhD  
Executive Chairman  
GLOBE Performance Solutions



November 10, 2017  
Vancouver, BC, Canada

Verification Body  
GLOBE Performance Solutions  
404 – 999 Canada Place | Vancouver, B.C | Canada | V6C 3E2

## Technology description and application

The Stormceptor® EF4 and EFO4 are treatment devices designed to remove oil, sediment, trash, debris, and pollutants attached to particulates from Stormwater and snowmelt runoff. The device takes the place of a conventional manhole within a storm drain system and offers design flexibility that works with various site constraints. The EFO4 is designed with a shorter bypass weir height, which accepts lower surface loading rate into the sump, thereby reducing re-entrainment of captured free floating light liquids.

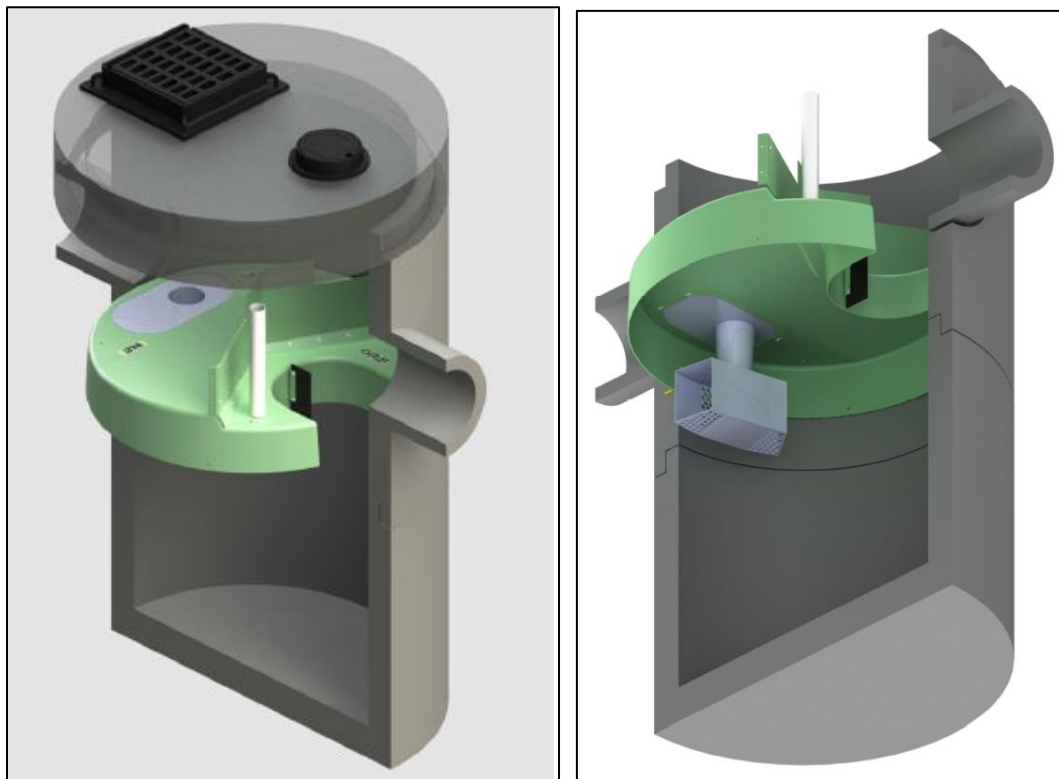

Figure 1. Graphic of typical inline Stormceptor® unit and core components.

Stormwater and snowmelt runoff enters the Stormceptor® EF/EFO's upper chamber through the inlet pipe(s) or a surface inlet grate. An insert divides the unit into lower and upper chambers and incorporates a weir to reduce influent velocity and separate influent (untreated) from effluent (treated) flows. Influent water ponds upstream of the insert's weir providing driving head for the water flowing downwards into the drop pipe where a vortex pulls the water into the lower chamber. The water diffuses at lower velocities in multiple directions through the drop pipe outlet openings. Oil and other floatables rise up and are trapped beneath the insert, while sediments undergo gravitational settling to the sump's bottom. Water from the sump can exit by flowing upward to the outlet riser onto the top side of the insert and downstream of the weir, where it discharges through the outlet pipe.

Maximum flow rate into the lower chamber is a function of weir height and drop pipe orifice diameter. The Stormceptor® EF and EFO are designed to allow a surface loading rate of 1135 L/min/m<sup>2</sup> (27.9 gal/min/ft<sup>2</sup>) and 535 L/min/m<sup>2</sup> (13.1 gal/min/ft<sup>2</sup>) into the lower chamber, respectively. When prescribed surface loading rates are exceeded, ponding water can overtop the weir height and bypass the lower treatment chamber, exiting directly through the outlet pipe. Hydraulic testing and scour testing demonstrate that the internal bypass effectively prevents scour at all bypass flow rates. Increasing the bypass flow rate does not increase the orifice-controlled flow rate into the lower treatment chamber where sediment is stored. This internal bypass feature allows for in-line installation, avoiding the cost of

additional bypass structures. During bypass, treatment continues in the lower chamber at the maximum flow rate. The Stormceptor® EFO's lower design surface loading rate is favorable for minimizing re-entrainment and washout of captured light liquids. Inspection of Stormceptor® EF and EFO devices is performed from grade by inserting a sediment probe through the outlet riser and an oil dipstick through the oil inspection pipe. The unit can be maintained by using a vacuum hose through the outlet riser.

## Performance conditions

The data and results published in this Technology Fact Sheet were obtained from the testing program conducted on the Imbrium Systems Inc.'s Stormceptor® OGS device, in accordance with the Procedure for Laboratory Testing of Oil-Grit Separators (Version 3.0, June 2014). The Procedure was prepared by the Toronto and Region Conservation Authority (TRCA) for Environment Canada's Environmental Technology Verification (ETV) Program. A copy of the Procedure may be accessed on the Canadian ETV website at [www.etvcanada.ca](http://www.etvcanada.ca).

## Performance claim(s)

### Capture test<sup>a</sup>:

During the capture test, the Stormceptor® EF OGS device, with a false floor set to 50% of the manufacturer's recommended maximum sediment storage depth and a constant influent test sediment concentration of 200 mg/L, removes 70, 64, 54, 48, 46, 44, and 49 percent of influent sediment by mass at surface loading rates of 40, 80, 200, 400, 600, 1000, and 1400 L/min/m<sup>2</sup>, respectively.

Stormceptor® EFO, with a false floor set to 50% of the manufacturer's recommended maximum sediment storage depth and a constant influent test sediment concentration of 200 mg/L, removes 70, 64, 54, 48, 42, 40, and 34 percent of influent sediment by mass at surface loading rates of 40, 80, 200, 400, 600, 1000, and 1400 L/min/m<sup>2</sup>, respectively.

### Scour test<sup>a</sup>:

During the scour test, the Stormceptor® EF and Stormceptor® EFO OGS devices, with 10.2 cm (4 inches) of test sediment pre-loaded onto a false floor reaching 50% of the manufacturer's recommended maximum sediment storage depth, generate corrected effluent concentrations of 4.6, 0.7, 0, 0.2, and 0.4 mg/L at 5-minute duration surface loading rates of 200, 800, 1400, 2000, and 2600 L/min/m<sup>2</sup>, respectively.

### Light liquid re-entrainment test<sup>a</sup>:

During the light liquid re-entrainment test, the Stormceptor® EFO OGS device with surrogate low-density polyethylene beads preloaded within the lower chamber oil collection zone, representing a floating light liquid volume equal to a depth of 50.8 mm over the sedimentation area, retained 100, 99.5, 99.8, 99.8, and 99.9 percent of loaded beads by mass during the 5-minute duration surface loading rates of 200, 800, 1400, 2000, and 2600 L/min/m<sup>2</sup>.

---

<sup>a</sup> The claim can be applied to other units smaller or larger than the tested unit as long as the untested units meet the scaling rule specified in the Procedure for Laboratory of Testing of Oil Grit Separators (Version 3.0, June 2014)

## Performance results

The test sediment consisted of ground silica (1 – 1000 micron) with a specific gravity of 2.65, uniformly mixed to meet the particle size distribution specified in the testing procedure. The *Procedure for Laboratory Testing of Oil Grit Separators* requires that the three sample average of the test sediment particle size distribution (PSD) meet the specified PSD percent less than values within a boundary threshold of 6%. The comparison of the average test sediment PSD to the CETV specified PSD in Figure 2 indicates that the test sediment used for the capture and scour tests met this condition.

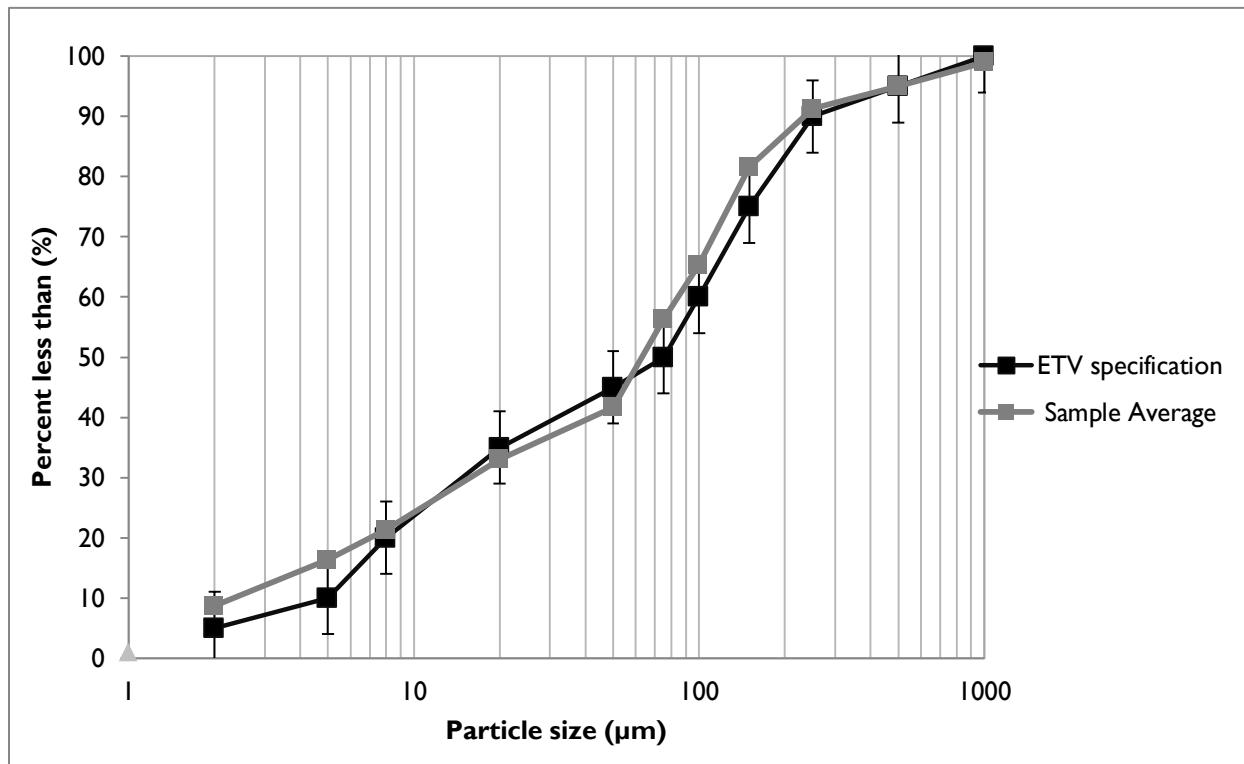

Figure 2. The three sample average particle size distribution (PSD) of the test sediment used for the capture and scour test compared to the specified PSD.

The capacity of the device to retain sediment was determined at seven surface loading rates using the modified mass balance method. This method involved measuring the mass and particle size distribution of the injected and retained sediment for each test run. Performance was evaluated with a false floor simulating the technology filled to 50% of the manufacturer’s recommended maximum sediment storage depth. The test was carried out with clean water that maintained a sediment concentration below 20 mg/L. Based on these conditions, removal efficiencies for individual particle size classes and for the test sediment as a whole were determined for each of the tested surface loading rates (Table 1). Since the EF and EFO models are identical except for the weir height, which bypasses flows from the EFO model at a surface loading rate of 535 L/min/m<sup>2</sup> (13.1 gpm/ft<sup>2</sup>), sediment capture tests at surface loading rates from 40 to 400 L/min/m<sup>2</sup> were only performed on the EF unit. Surface loading rates of 600, 1000, and 1400 L/min/m<sup>2</sup> were tested on both units separately. Results for the EFO model at these higher flow rates are presented in Table 2.

In some instances, the removal efficiencies were above 100% for certain particle size fractions. These discrepancies are not unique to any one test laboratory and may be attributed to errors relating to the blending of sediment, collection of representative samples for laboratory submission, and laboratory

analysis of PSD. Due to these errors, caution should be exercised in applying the removal efficiencies by particle size fraction for the purposes of sizing the tested device (see [Bulletin # CETV 2016-11-0001](#)). The results for “all particle sizes by mass balance” (see Table 1 and 2) are based on measurements of the total injected and retained sediment mass, and are therefore not subject to blending, sampling or PSD analysis errors.

Table 1. Removal efficiencies (%) of the EF4 at specified surface loading rates

Particle size fraction (µm)	Surface loading rate (L/min/m <sup>2</sup> )						
	40	80	200	400	600	1000	1400
>500	90	58	58	100*	86	72	100*
250 - 500	100*	100*	100	100*	100*	100*	100*
150 - 250	90	82	26	100*	100*	67	90
105 - 150	100*	100*	100*	100*	100*	100*	100
75 - 105	100*	92	74	82	77	68	76
53 - 75	Undefined <sup>a</sup>	56	100*	72	69	50	80
20 - 53	54	100*	54	33	36	40	31
8 - 20	67	52	25	21	17	20	20
5 – 8	33	29	11	12	9	7	19
<5	13	0	0	0	0	0	4
<b>All particle sizes by mass balance</b>	<b>70.4</b>	<b>63.8</b>	<b>53.9</b>	<b>47.5</b>	<b>46.0</b>	<b>43.7</b>	<b>49.0</b>

<sup>a</sup> An outlier in the feed sample sieve data resulted in a negative removal efficiency for this size fraction.

\* Removal efficiencies were calculated to be above 100%. Calculated values ranged between 101 and 171% (average 128%). See text and [Bulletin # CETV 2016-11-0001](#) for more information.

Table 2. Removal efficiencies (%) of the EFO4 at surface loading rates above the bypass rate of 535 L/min/m<sup>2</sup>

Particle size fraction (µm)	Surface loading rate (L/min/m <sup>2</sup> )		
	600	1000	1400
>500	89	83	100*
250 - 500	90	100*	92
150 - 250	90	67	100*
105 - 150	85	92	77
75 - 105	80	71	65
53 - 75	60	31	36
20 - 53	33	43	23
8 - 20	17	23	15
5 – 8	10	3	3
<5	0	0	0
<b>All particle sizes by mass balance</b>	<b>41.7</b>	<b>39.7</b>	<b>34.2</b>

\* Removal efficiencies were calculated to be above 100%. Calculated values ranged between 103 and 111% (average 107%). See text and [Bulletin # CETV 2016-11-0001](#) for more information.

Figure 3 compares the particle size distribution (PSD) of the three sample average of the test sediment to the PSD of the sediment retained by the EF4 at each of the tested surface loading rates. Figure 4 shows the same graph for the EFO4 unit at surface loading rates above the bypass rate of 535 L/min/m<sup>2</sup>.



As expected, the capture efficiency for fine particles in both units was generally found to decrease as surface loading rates increased.

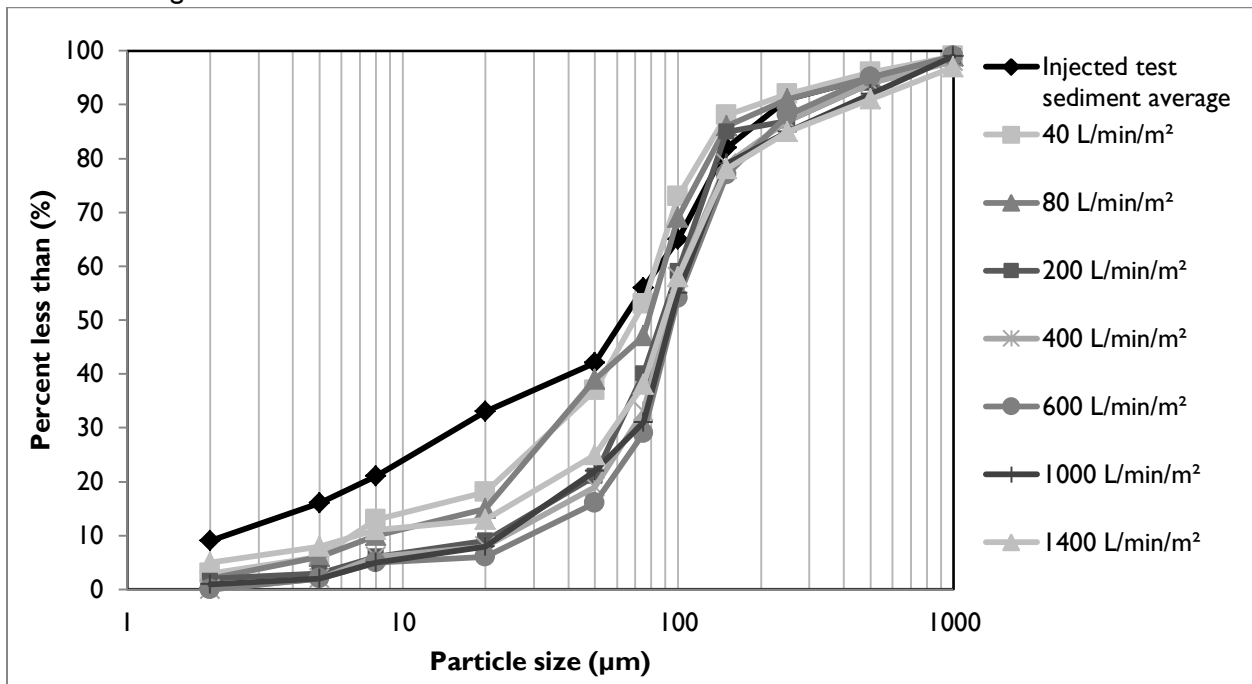

Figure 3. Particle size distribution of sediment retained in the EF4 in relation to the injected test sediment average.

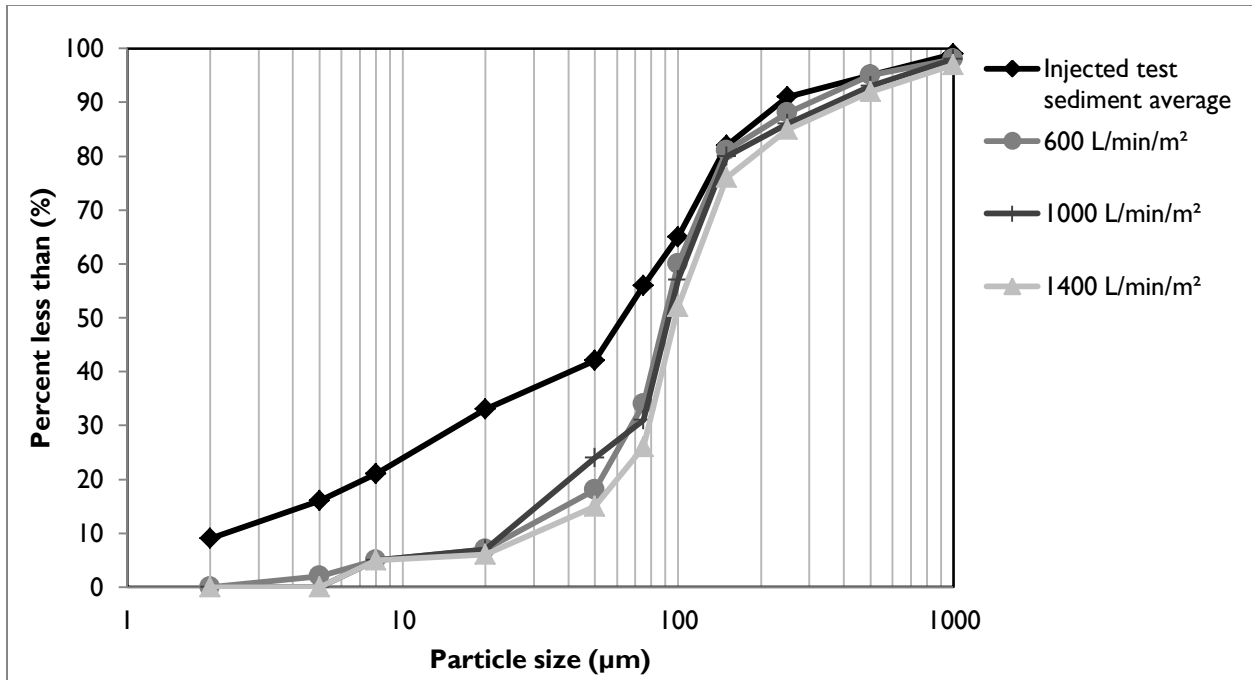

Figure 4. Particle size distribution of sediment retained in the EFO4 in relation to the injected test sediment average at surface loading rates above the bypass rate of 535 L/min/m<sup>2</sup>

Table 4 shows the results of the sediment scour and re-suspension test for the EF4 unit. The EFO4 was not tested as it was reasonably assumed that scour rates would be lower given that flow bypass occurs at a lower surface loading rate. The scour test involved preloading 10.2 cm of fresh test sediment into

the sedimentation sump of the device. The sediment was placed on a false floor to mimic a device filled to 50% of the maximum recommended sediment storage depth. Clean water was run through the device at five surface loading rates over a 30 minute period. Each flow rate was maintained for 5 minutes with a one minute transition time between flow rates. Effluent samples were collected at one minute sampling intervals and analyzed for Suspended Sediment Concentration (SSC) and PSD by recognized methods. The effluent samples were subsequently adjusted based on the background concentration of the influent water. Typically, the smallest 5% of particles captured during the 40 L/min/m<sup>2</sup> sediment capture test is also used to adjust the concentration, as per the method described in [Bulletin # CETV 2016-09-0001](#). However, since the composites of effluent concentrations were below the Reporting Detection Limit of the Laser Diffraction PSD methodology, this adjustment was not made. Results showed average adjusted effluent sediment concentrations below 5 mg/L at all tested surface loading rates.

It should be noted that the EF4 starts to internally bypass water at 1135 L/min/m<sup>2</sup>, potentially resulting in the dilution of effluent concentrations, which would not normally occur under typical field conditions because the field influent concentration would contain a much higher sediment concentration than during the lab test. Recalculation of effluent concentrations to account for dilution at surface loading rates above the bypass rate showed sediment effluent concentrations to be below 1.6 mg/L.

Table 4. Scour test adjusted effluent sediment concentration.

Run	Surface loading rate (L/min/m <sup>2</sup> )	Run time (min)	Background sample concentration (mg/L)	Adjusted effluent suspended sediment concentration (mg/L) <sup>a</sup>	Average (mg/L)
1	200	1:00	<RDL	11.9	4.6
		2:00		7.0	
		3:00		4.4	
		4:00		2.2	
		5:00		1.0	
		6:00		1.2	
2	800	7:00	<RDL	1.1	0.7
		8:00		0.9	
		9:00		0.6	
		10:00		1.4	
		11:00		0.1	
		12:00		0	
3	1400	13:00	<RDL	0	0
		14:00		0.1	
		15:00		0	
		16:00		0	
		17:00		0	
		18:00		0	
4	2000	19:00	1.2	0.2	0.2
		20:00		0	
		21:00		0	
		22:00		0.7	
		23:00		0	

		24:00		0.4	
5	2600	25:00	1.6	0.3	0.4
		26:00		0.4	
		27:00		0.7	
		28:00		0.4	
		29:00		0.2	
		30:00		0.4	

<sup>a</sup> The adjusted effluent suspended sediment concentration represents the actual measured effluent concentration minus the background concentration. For more information see [Bulletin # CETV 2016-09-0001](#).

The results of the light liquid re-entrainment test used to evaluate the unit’s capacity to prevent re-entrainment of light liquids are reported in Table 5. The test involved preloading 58.3 L (corresponding to a 5 cm depth over the collection sump area of 1.17m<sup>2</sup>) of surrogate low-density polyethylene beads within the oil collection skirt and running clean water through the device continuously at five surface loading rates (200, 800, 1400, 2000, and 2600 L/min/m<sup>2</sup>). Each flow rate was maintained for 5 minutes with approximately 1 minute transition time between flow rates. The effluent flow was screened to capture all re-entrained pellets throughout the test.

Table 5. Light liquid re-entrainment test results for the EFO4.

Surface Loading Rate (L/min/m <sup>2</sup> )	Time Stamp	Amount of Beads Re-entrained			
		Mass (g)	Volume (L) <sup>a</sup>	% of Pre-loaded Mass Re-entrained	% of Pre-loaded Mass Retained
200	62	0	0	0.00	100
800	247	168.45	0.3	0.52	99.48
1400	432	51.88	0.09	0.16	99.83
2000	617	55.54	0.1	0.17	99.84
2600	802	19.73	0.035	0.06	99.94
Total Re-entrained		295.60	0.525	0.91	--
Total Retained		32403	57.78	--	99.09
Total Loaded		32699	58.3	--	--

<sup>a</sup> Determined from bead bulk density of 0.56074 g/cm<sup>3</sup>

## Variations from testing Procedure

The following minor deviations from the *Procedure for Laboratory Testing of Oil-Grit Separators* (Version 3.0, June 2014) have been noted:

1. During the capture test, the 40 L/min/m<sup>2</sup> and 80 L/min/m<sup>2</sup> surface loading rates were evaluated over 3 and 2 days respectively due to the long duration needed to feed the required minimum of 11.3 kg of test sediment into the unit at these lower flow rates. Pumps were shut down at the end of each intermediate day, and turned on again the following morning. The target flow rate was re-established within 30 seconds of switching on the pump. This procedure may have allowed sediments to be captured that otherwise may have exited the unit if the test was

continuous. On the basis of practical considerations, this variance was approved by the verifier prior to testing.

2. During the scour test, the coefficient of variation (COV) for the lowest flow rate tested (200 L/min/m<sup>2</sup>) was 0.07, which exceeded the specified limit of 0.04 target specified in the OGS Procedure. A pump capable of attaining the highest flow rate of 3036 L/min had difficulty maintaining the lowest flow of 234 L/min but still remained within +/- 10% of the target flow and is viewed as having very little impact on the observed results. Similarly, for the light liquid re-entrainment test the COV for the flow rate of the 200 L/min/m<sup>2</sup> run was 0.049, exceeding the limit of 0.04, but is believed to introduce negligible bias.
3. Due to pressure build up in the filters, the runs at 1000 L/min/m<sup>2</sup> for the Stormceptor® EF4 and 1000 and 1400 L/min/m<sup>2</sup> for the Stormceptor® EFO4 were slightly shorter than the target. The run times were 54, 59 and 43 minutes respectively, versus targets of 60 and 50 minutes. The final feed samples were timed to coincide with the end of the run. Since >25 lbs of sediment was fed, the shortened time did not invalidate the runs.

## Verification

The verification was completed by the Verification Expert, Toronto and Region Conservation Authority, contracted by GLOBE Performance Solutions, using the International Standard **ISO 14034:2016 Environmental management – Environmental technology verification (ETV)**. Data and information provided by Imbrium Systems Inc. to support the performance claim included the following: Performance test report prepared by Good Harbour Laboratories, and dated September 8, 2017; the report is based on testing completed in accordance with the Procedure for Laboratory Testing of Oil-Grit Separators (Version 3.0, June 2014).

## What is ISO 14034:2016 Environmental management – Environmental technology verification (ETV)?

ISO 14034:2016 specifies principles, procedures and requirements for environmental technology verification (ETV), and was developed and published by the *International Organization for Standardization (ISO)*. The objective of ETV is to provide credible, reliable and independent verification of the performance of environmental technologies. An environmental technology is a technology that either results in an environmental added value or measures parameters that indicate an environmental impact. Such technologies have an increasingly important role in addressing environmental challenges and achieving sustainable development.

### For more information on the Stormceptor® EF4 and EFO4 please contact:

Imbrium Systems, Inc.  
407 Fairview Drive  
Whitby, ON  
L1N 3A9, Canada  
Tel: 416-960-9900  
info@imbriumsystems.com

### For more information on ISO 14034:2016 / ETV please contact:

GLOBE Performance Solutions  
World Trade Centre  
404 – 999 Canada Place  
Vancouver, BC  
V6C 3E2 Canada  
Tel: 604-695-5018 / Toll Free: 1-855-695-5018  
etv@globeperformance.com

### Limitation of verification

GLOBE Performance Solutions and the Verification Expert provide the verification services solely on the basis of the information supplied by the applicant or vendor and assume no liability thereafter. The responsibility for the information supplied remains solely with the applicant or vendor and the liability for the purchase, installation, and operation (whether consequential or otherwise) is not transferred to any other party as a result of the verification.



Ottawa Septic Bureau des systèmes  
System Office septiques d'Ottawa

3889 Rideau Valley Drive Box 599 Manotick, ON K4M 1A5

Phone: 613-692-3571 **PRESS "4" for septic office** 1-800-267-3504 Fax: 613-692-1507 Email: [septic@rvca.ca](mailto:septic@rvca.ca)

SITE ADDRESS: 8520 McARTHUR Township: OSG-HUN-GLO-FIT-CUM-NEP-GOU-RID-KAN-TOR

CONTACT: 1. MARCZUK 2. X 3. X

**INFORMATION FOR OWNER/APPLICANT**

Attached is your Sewage System Permit. A minimum of two inspections are required before your proposed sewage system can be approved for use (additional inspections may be required for clay soils/bedrock and/or re-inspections). Inspections must be requested in writing. Please see attached:

- Inspection fax request form (all inspections MUST be requested in writing)
- As-built components and drawing form
- Copy of the approved application and schedule pages
- Approved Part 8 permit: \*Electronic copy only – Be sure to INCLUDE in Building Application Package for Plans Examiner at CITY of OTTAWA client services, if NEW or RENO construction project.

**Special Note**  
- A permit is valid for 12 months from the original date of issuance noted in "permit date". If lapsed, it may be renewed only once for a period of 12 months from the date of expiry.

- No person shall make a material change or cause a material change to be made to a plan, specification, document or other information on the basis of which a permit was issued without notifying, filing details with and obtaining the authorization of the Chief Building Official. (Building Code Act 1992, c.23, s.8(12))

**Sewage System Permit Construction Requirements**

**1. Clay Soils/Bedrock only (if required per issued Approval)**

In clay soils/bedrock, a site preparation inspection is required. The total contact area must be properly prepared. Scarification must be done under dry conditions prior to importing leaching bed fill.

**2. Installation Inspection – 2<sup>nd</sup> inspection**

When the sewage system is substantially completed (i.e., before the final fill is placed over the septic tank and leaching bed system) an installation inspection is required. Prior to any inspection request, the following must be submitted:

- "as-built components" and "as-built drawings" — see attached form
- "engineer letter" — if the system is engineered
- grain size analysis and weight bills for all Filter Media types of septic systems
- Weight bills for washed septic stone, where applicable
- Maintenance/service contract for treatment unit installed

**3. Final Grading Inspection – 3<sup>rd</sup> inspection**

When construction of the sewage system is complete, a final grading inspection is required. Before a Certificate of Completion can be issued, the following must be complete:

- The leaching bed and septic tank must be covered with sand fill and topsoil and graded accordingly
- All conditions of the Sewage System Permit & comments on the installation inspection report must be met
- The depth of cover & material type must be identified by inspection pipes or holes placed over trenches at 4 corners of bed
- The 4 corners of the bed must be staked

JULY 2020

Location: 2:Administration templates\CoverPart8page

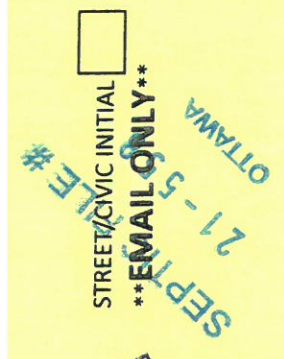
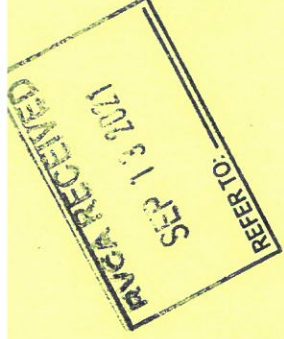

# Application for a Permit to Construct or Demolish

This form is authorized under subsection 8(1.1) of the Building Code Act, 1992

<b>For use by Principal Authority</b>		<b>SEPTIC FILE #</b>	<b>BWPA RECEIVE</b>
Application number:	Permit number (if different):	21-558	SEP 13 2021
Date received:	Roll number:	OTTAWA	REFER TO:

## OTTAWA SEPTIC SYSTEM OFFICE

Application submitted to: \_\_\_\_\_  
(Name of municipality, upper-tier municipality, board of health or conservation authority)

### A. Project information

Building number, street name 8520 McArton Road	Unit number	Lot/con.
Municipality Ottawa	Postal code K0A 1B0	Plan number/other description PLAN 4R-31570. (Part 1 of PIN04444-0010 LT)
Project value est. \$	Area of work (m <sup>2</sup> )	

### B. Purpose of application

<input checked="" type="checkbox"/> New construction	Addition to an existing building	Alteration/repair	Demolition	Conditional Permit
Proposed use of building wild bird hospital	Current use of building			
Description of proposed work ***COMMERCIAL***				

### C. Applicant

Applicant is:		Owner or	Authorized agent of owner
Last name Marczuk	First name Juliette	Corporation or partnership Ottawa Valley Wild Bird Care Centre	Unit number Lot/con.
Street address 20 Hartsmere Dr.	Postal code K2S 1K2	Province ON	E-mail juliette@wildbirdcarecentre.org
Municipality Ottawa	Fax ( )		Cell number ( 613)291-1137

### D. Owner (if different from applicant)

Last name	First name	Corporation or partnership	Unit number	Lot/con.
Street address	Postal code	Province	E-mail	
Municipality	Fax		Cell number	
Telephone number ( )				

Application for a Permit to Construct or Demolish – Effective January 1, 2014

**E. Builder (optional)**

Last name	First name	Corporation or partnership	
Street address	SEPTIC FILE #		
Municipality	Postal code	Province	Unit number 3 20 Lot/cont.
Telephone number ( )	Fax ( )	OTTAWA	REFER TO:
			Cell number ( )

**F. Tarion Warranty Corporation (Ontario New Home Warranty Program)**

i. Is proposed construction for a new home as defined in the <i>Ontario New Home Warranties Plan Act</i> ? If no, go to section G.	Yes	No
ii. Is registration required under the <i>Ontario New Home Warranties Plan Act</i> ?	Yes	No

iii. If yes to (ii) provide registration number(s):

**G. Required Schedules**

- i) Attach Schedule 1 for each individual who reviews and takes responsibility for design activities.  
 ii) Attach Schedule 2 where application is to construct on-site, install or repair a sewage system.

**H. Completeness and compliance with applicable law**

i) This application meets all the requirements of clauses 1.3.1.3 (5) (a) to (d) of Division C of the Building Code (the application is made in the correct form and by the owner or authorized agent, all applicable fields have been completed on the application and required schedules, and all required schedules are submitted). Payment has been made of all fees that are required, under the applicable by-law, resolution or regulation made under clause 7(1)(c) of the <i>Building Code Act, 1992</i> , to be paid when the application is made.	Yes	X	No
ii) This application is accompanied by the plans and specifications prescribed by the applicable by-law, resolution or regulation made under clause 7(1)(b) of the <i>Building Code Act, 1992</i> .	Yes	X	No
iii) This application is accompanied by the information and documents prescribed by the applicable by-law, resolution or regulation made under clause 7(1)(b) of the <i>Building Code Act, 1992</i> which enable the chief building official to determine whether the proposed building, construction or demolition will contravene any applicable law.	Yes	X	No
iv) The proposed building, construction or demolition will not contravene any applicable law.	Yes	X	No

**I. Declaration of applicant**

I, Juliette Marczuk  
 (print name)

declare that:

- The information contained in this application, attached schedules, attached plans and specifications, and other attached documentation is true to the best of my knowledge.
- If the owner is a corporation or partnership, I have the authority to bind the corporation or partnership.

Date Sept. 13, 2021

Signature of applicant

Personal information contained in this form and schedules is collected under the authority of subsection 8(1.1) of the *Building Code Act, 1992*, and will be used in the administration and enforcement of the *Building Code Act, 1992*. Questions about the collection of personal information may be addressed to: a) the Chief Building Official of the municipality or upper-tier municipality to which this application is being made, or, b) the inspector having the powers and duties of a chief building official in relation to sewage systems or plumbing for an upper-tier municipality, board of health or conservation authority to whom this application is made, or, c) Director, Building and Development Branch, Ministry of Municipal Affairs and Housing 777 Bay St., 2nd Floor, Toronto, M5G 2E5 (416) 585-6666.

# Schedule 1: Designer Information

Use one form for each individual who reviews and takes responsibility for design activities with respect to the project.

<b>A. Project Information</b>		Unit no. <b>21-558</b>		Lot/con. <b>SEP 13 2021</b>	
Building number, street name		Postal code		Plan number/other description	
Municipality		KIT 0E4		OTTAWA	
<b>B. Individual who reviews and takes responsibility for design activities</b>					
Name		Firm		REFER TO:	
Husham Almansour, P.Eng.		Advanced Design, Assessment, and Development Incorporated			
Street address		Unit no.		Lot/con.	
135 Mangrove Cres.,					
Municipality		Postal code		E-mail	
Gloucester		K1T 0E4		Ontario	
Telephone number		Fax number		Cell number	
( 613 ) 526 1111		( ) N/A		( 613 ) 601 2139	
<b>C. Design activities undertaken by individual identified in Section B. [Building Code Table 3.5.2.1. of Division C]</b>					
House		HVAC – House		Building Structural	
Small Buildings		Building Services		Plumbing – House	
Large Buildings		Detection, Lighting and Power		Plumbing – All Buildings	
Complex Buildings		Fire Protection		On-site Sewage Systems	
Description of designer's work					
Design the septic system that includes, estimation of the daily design sewage flow, septic system design details, and sewage system management/ Monitoring.					
<b>D. Declaration of Designer</b>					
I <u>Husham Almansour, P.Eng, Ph.D.</u> declare that (choose one as appropriate):					
(print name)					
I review and take responsibility for the design work on behalf of a firm registered under subsection 3.2.4. of Division C, of the Building Code. I am qualified, and the firm is registered, in the appropriate classes/categories.					
Individual BCIN: _____					
Firm BCIN: _____					
I review and take responsibility for the design and am qualified in the appropriate category as an "other designer" under subsection 3.2.5. of Division C, of the Building Code.					
Individual BCIN: _____					
Basis for exemption from registration: _____					
The design work is exempt from the registration and qualification requirements of the Building Code.					
Basis for exemption from registration and qualification: _____					
I certify that:					
1. The information contained in this schedule is true to the best of my knowledge.					
2. I have submitted this application with the knowledge and consent of the firm.					
Date		September, 10, 2021		Signature of Designer	



**NOTE:**

- For the purposes of this form, "individual" means the "person" referred to in Clause 3.2.4.7(1) (c) of Division C, Article 3.2.5.1. of Division C, and all other persons who are exempt from qualification under Subsections 3.2.4. and 3.2.5. of Division C.
- Schedule 1 is not required to be completed by a holder of a license, temporary license, or a certificate of practice, issued by the Ontario Association of Architects. Schedule 1 is also not required to be completed by a holder of a license to practise, a limited license to practise, or a certificate of authorization, issued by the Association of Professional Engineers of Ontario.



# Schedule 2: Sewage System Installer Information

<b>A. Project Information</b>		Unit number <b>RVCA RECEIVED</b>	
Building number, street name		SEPTIC FILE #	
Municipality	Postal code	Plan number/other description	SEP 13 2021
<b>B. Sewage system installer</b>		Is the installer of the sewage system engaged in the business of constructing on-site, installing, <del>repairing</del> , <del>servicing</del> , <del>cleaning</del> or emptying sewage systems, in accordance with Building Code Article 3.3.1.1, Division C?	
Yes (Continue to Section C)		No (Continue to Section E)	
<b>C. Registered installer information (where answer to B is "Yes")</b>		X Installer unknown at time of application (Continue to Section E)	
Name	BCIN		
Street address	Unit number		Lot/con.
Municipality	Postal code	Province	E-mail
Telephone number ( ) ( )	Fax ( ) ( )		Cell number ( ) ( )
<b>D. Qualified supervisor information (where answer to section B is "Yes")</b>			
Name of qualified supervisor(s)		Building Code Identification Number (BCIN)	
<b>E. Declaration of Applicant:</b>			
I <u>Juliette Marczuk</u> (print name) declare that:			
I am the applicant for the permit to construct the sewage system. If the installer is unknown at time of application, I shall submit a new Schedule 2 prior to construction when the installer is known;			
<u>OR</u>			
I am the holder of the permit to construct the sewage system, and am submitting a new Schedule 2, now that the installer is known.			
I certify that:			
1. The information contained in this schedule is true to the best of my knowledge.			
2. If the owner is a corporation or partnership, I have the authority to bind the corporation or partnership.			
Date	Sept. 13, 2021	Signature of applicant	



Do Not Complete  
Permit # \_\_\_\_\_  
Revision # \_\_\_\_\_

**Permit RECEIVED**

SEP 13 2021

REFER TO: \_\_\_\_\_

1. Engineered

- Yes
- No

2. Water supply

- Proposed
- Existing

3. Type of work proposed

- New Installation
- Replacement
- Alteration

4. Type of Well

- Dug/bored/Sandpoint well
- Drilled well
- Municipal
- Other

5. Residential Sewage Design Flow Info.

**Bedrooms** \_\_\_\_\_

**House (floor area)** \_\_\_\_\_ m<sup>2</sup>

**People** \_\_\_\_\_

**Total Fixture Units** \_\_\_\_\_ (Schedule 8)

**Residential Flow** \_\_\_\_\_ L/day

6. Sewage Design Flow **Other Occupancies**

**Design Flow** 5,500 L/day

Detailed sewage flow calculations:  
Sanitary Servicing for the Building: As per OBC, Table 8.2.1.3.B  
Q<sub>daily</sub> = 3450 L/day. (See attached report for details)  
Servicing for Outdoor Activities: Q<sub>activity</sub> = 2000 L/day (maximum)

7. Type of System

- Treatment Unit \_\_\_\_\_
- Class 2 – Leaching Pit
- Class 3 – Cesspool
- Class 4 – Shallow Buried Trench
- Class 4 – Trench (Schedule 9)
  - Fully raised
  - Partially raised
  - In-ground
- Class 4 – Filter Media (Schedule 10)
  - Fully raised
  - Partially raised
  - In-ground

- Class 4 – BMEC Area Bed (Schedule 11)
  - Fully raised
  - Partially raised
  - In-ground
- Class 4 – “Type A” Dispersal (Schedule 13)
  - Fully raised
  - Partially raised
  - In-ground
- Class 4 – “Type B” Dispersal (Schedule 14)
  - Fully raised
  - Partially raised
  - In-ground

- Class 5 – Holding Tank (9000L min)
- Tank/TreatmentUnit/PumpChamber ONLY
- Effluent Filter/Risers ONLY



OTTAWA  
Schedule 5  
Sewage System Details

Do Not Complete  
Permit No \_\_\_\_\_  
Revision No \_\_\_\_\_  
Date \_\_\_\_\_  
**RVCA RECEIVED**

SEP 13 2021

Type of System Class 4: Burid Tile Bed - Absorption Trench Method (Schedule 4)  
 Septic/Holding Tank Size: 12,500 & 6000 Litres Make: To be decided REFER TO:  
 Septic Tank Effluent Filter Make: To decided Model: To decided

Treatment Unit - Make & Model \_\_\_\_\_  
 Number of Units:  Other: \_\_\_\_\_  
 Refer to Typical Drawing #  Pump(s) required \_\_\_\_\_  
 Mantle Information: Pump Rate \_\_\_\_\_ L/15min

Native or imported = 15m in \_\_\_\_\_ direction(s) **Note:** Alarm required for all  
 pumping systems

Slope subgrade \_\_\_\_\_ % slope  
 \_\_\_\_\_ direction(s)

Site to be Scarified (If clay) YES / NO  
 Clay Seal Required (If bedrock) YES / NO

**Trench**  **Shallow Buried Trench**  
 Distribution Pipe Length \_\_\_\_\_ m Pipe Length \_\_\_\_\_ m  
 Loading Area \_\_\_\_\_ m<sup>2</sup>  
 Type of Chamber \_\_\_\_\_  **Filter Media Bed**  
 Length of Chamber \_\_\_\_\_ m Stone \_\_\_\_\_ m<sup>2</sup>  
 Extended Base \_\_\_\_\_ m<sup>2</sup>

**Dispersal Bed**  
 **BMEC**  **Type A**  **Type B** Pipe \_\_\_\_\_ m  
 Stone \_\_\_\_\_ m<sup>2</sup> Weight of Filter Media \_\_\_\_\_ Kg  
 Sand \_\_\_\_\_ m<sup>2</sup> Loading Area \_\_\_\_\_ m  
 Pipe \_\_\_\_\_ m<sup>2</sup>  
 Linear Loading \_\_\_\_\_ L/m<sup>2</sup>

**Tank/Treatment Unit/Pump Chamber Replacement ONLY**

**Effluent Filter & Riser ONLY**

Construction Notes:

\_\_\_\_\_  
 \_\_\_\_\_  
 \_\_\_\_\_



**Soil and Water Table Information**  
**(Minimum depth of test pit: 2 metres)**

Do Not Complete  
Permit # \_\_\_\_\_  
Revision # \_\_\_\_\_  
Date \_\_\_\_\_

**RVCA RECEIVED**  
SEP 13 2021

Name of Applicant/Agent: \_\_\_\_\_ Time: \_\_\_\_\_  
Date: \_\_\_\_\_  
Applicant/Agent Signature: \_\_\_\_\_  
Inspector: \_\_\_\_\_  
Date: \_\_\_\_\_  
Inspector Signature: \_\_\_\_\_

REFER TO: \_\_\_\_\_

Time: \_\_\_\_\_

Time: \_\_\_\_\_

EG (.....)	Soil Description	T	EG (.....)	Soil Description
.5m	132.4 Very loose, moist, dark brown and brown silty sand, trace organics, trace gravel (remolded)		.5m	
1.0m	131.9 Light brown silty sand, some gravel, occasional oxidization (TILL) compact Water Table		1.0m	
1.5m	131.4 very dense		1.5m	
2.0m	131.15 coarse angular gravel trace limestone		2.0m	
	130.9			

Test pits not available for inspection. Engineer assumes all liability for soil and HGWT info/lev's

EG (.....)	Soil Description	T	EG (.....)	Soil Description
.5m	132.4 Very loose, moist, dark brown and brown silty sand, trace organics, trace gravel (remolded)		.5m	
1.0m	131.9 Compact, moist to wet, light brown silty sand, some gravel, occasional oxidization (TILL)		1.0m	
1.5m	131.4 highly fractured Limestone Bedrock Occasional oxidization RQD = 0% TCR = 96% fractured/foot = 4 Water Table		1.5m	
2.0m	131.15 moderately fractured		2.0m	
	130.9			

**LEGEND**

BR = Bedrock

GW/T = Ground water table

HGWT = High ground water table

M = metres

EG = Existing grade

T = percolation rate





**Schedule 8**  
**Fixture unit count**

Do Not Complete  
Permit #

Revision #

**PROCA RECEIVED**

SEP 13 2021

Fixtures	# Existing	+ # Proposed	X unit coefficient	Fixture Count
<b>Bathroom</b>				
Bathroom group (toilet, sink and tub or shower) installed in the <u>same</u> room		+	X 6	=
Bathub with/without overhead shower		+	X 1.5	=
Shower stall		+	X 1.5	=
Wash basin (SINK) (1½inch trap)		+	X 1.5	=
Watercloset (TOILET) tank operated		+	X 4	=
Bidet		+	X 1	=
<b>Kitchen</b>				
Dishwasher		+	X 1	=
Sink with/without garbage grinder(s), domestic and other small type single, double or 2 single with a common trap		+	X 1.5	=
<b>Other</b>				
Domestic washing machine		+	X 1.5	=
Combination sink and laundry tray single or double (Installed on 1½ trap)		+	X 1.5	=

**\*Total:**

**\*Insert the TOTAL in section 5 of Schedule 4 (0.Reg 151/13 Table 7.4.9.3)**

1. **Sump pumps and floor drains are not to be connected to the sewage system.** Connection of such fixtures to a sewage system may lead to a hydraulic failure of the said system. The above mentioned fixtures should be discharged separately to an approved Class 2 (leaching pit) sewage system.
2. Where laundry waste is not more than 20% of the total daily design sanitary sewage flow, it may discharge to a sewage system (Part 8, OBC, 8.1.3.1(2)).

Agent/Owner signature

Date

**Ottawa Septic Bureau des systèmes  
System Office septiques d'Ottawa**

**TYPICAL DRAWING A**  
BURIED OR RAISED TILE BED - ABSORPTION TRENCH METHOD

OTAWA  
SEPTIC FILE #  
21-558  
SEP 16/21

Proposed Installation Grades	Approved Installation Grades	Existing Installation Grades
134.9	134.9	134.9
133.9	133.9	133.9
133.5	133.5	133.5
132.5	132.5	132.5

RVCA RECEIVED  
SEP 13 2021

Water Table at 131.4

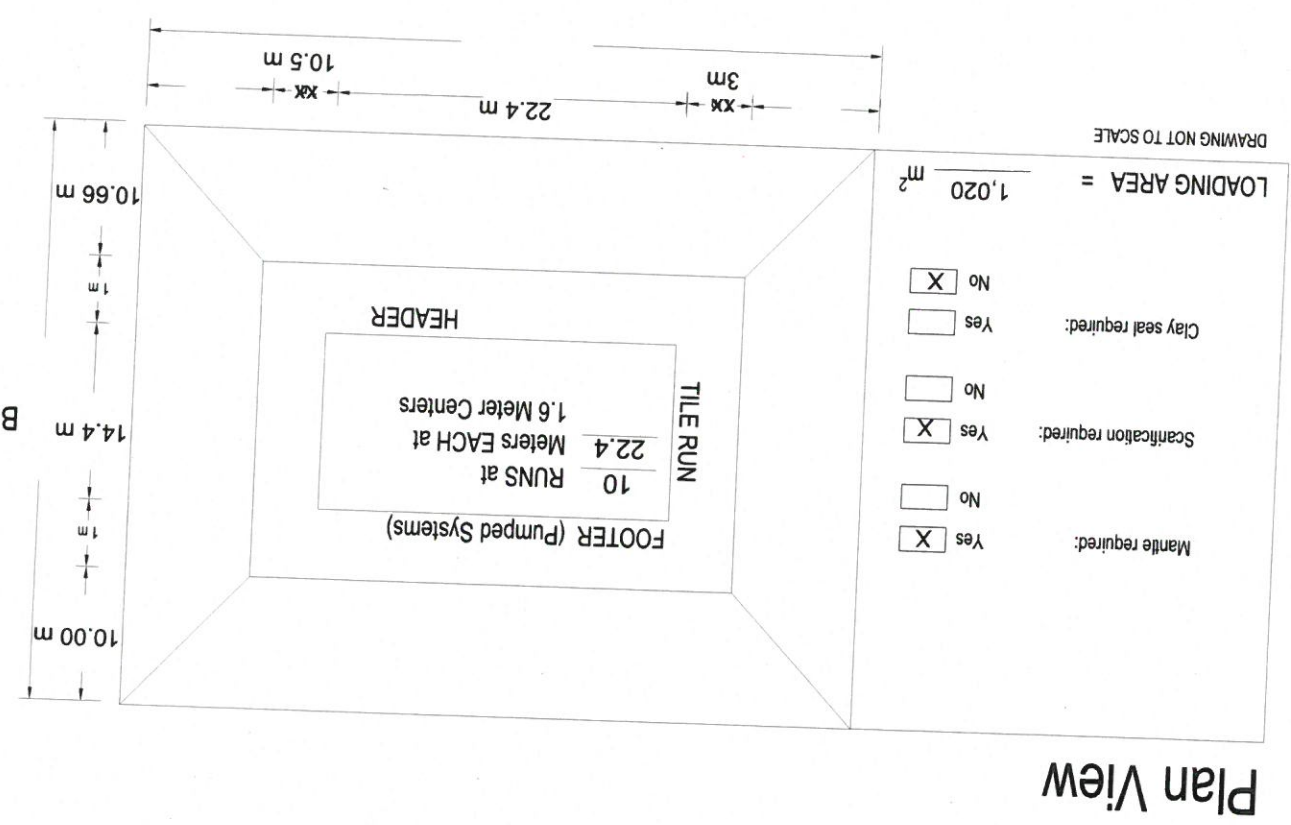

Plan View

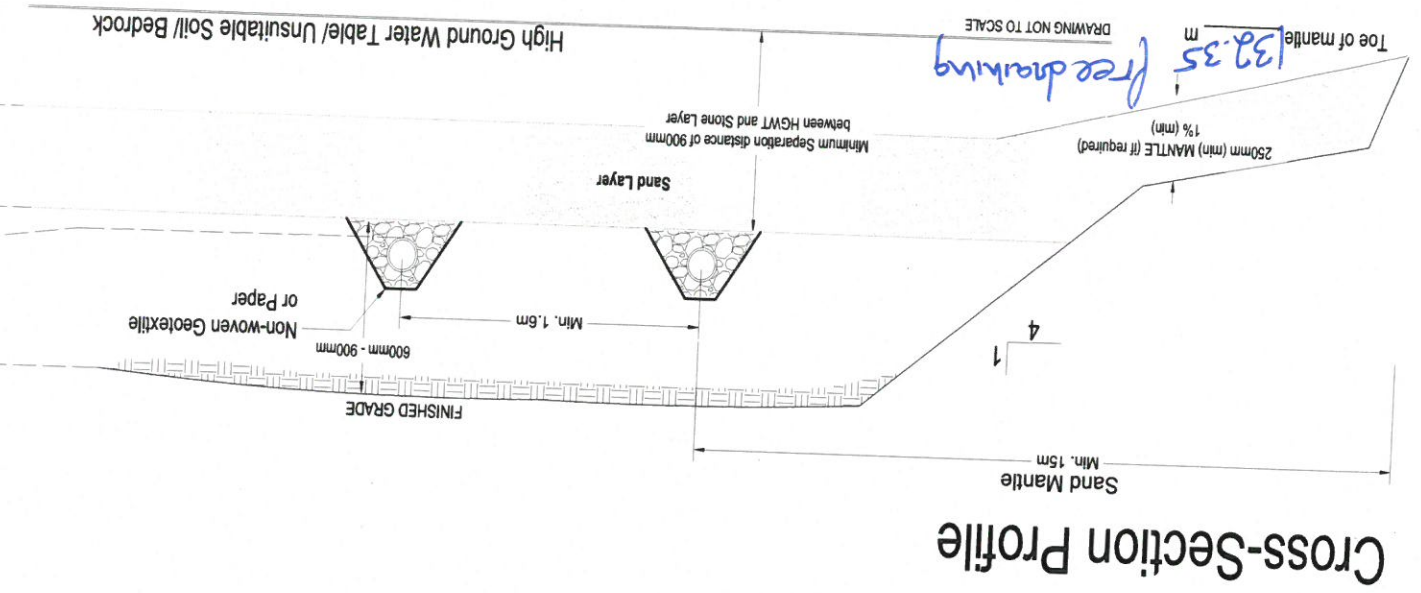

Cross-Section Profile





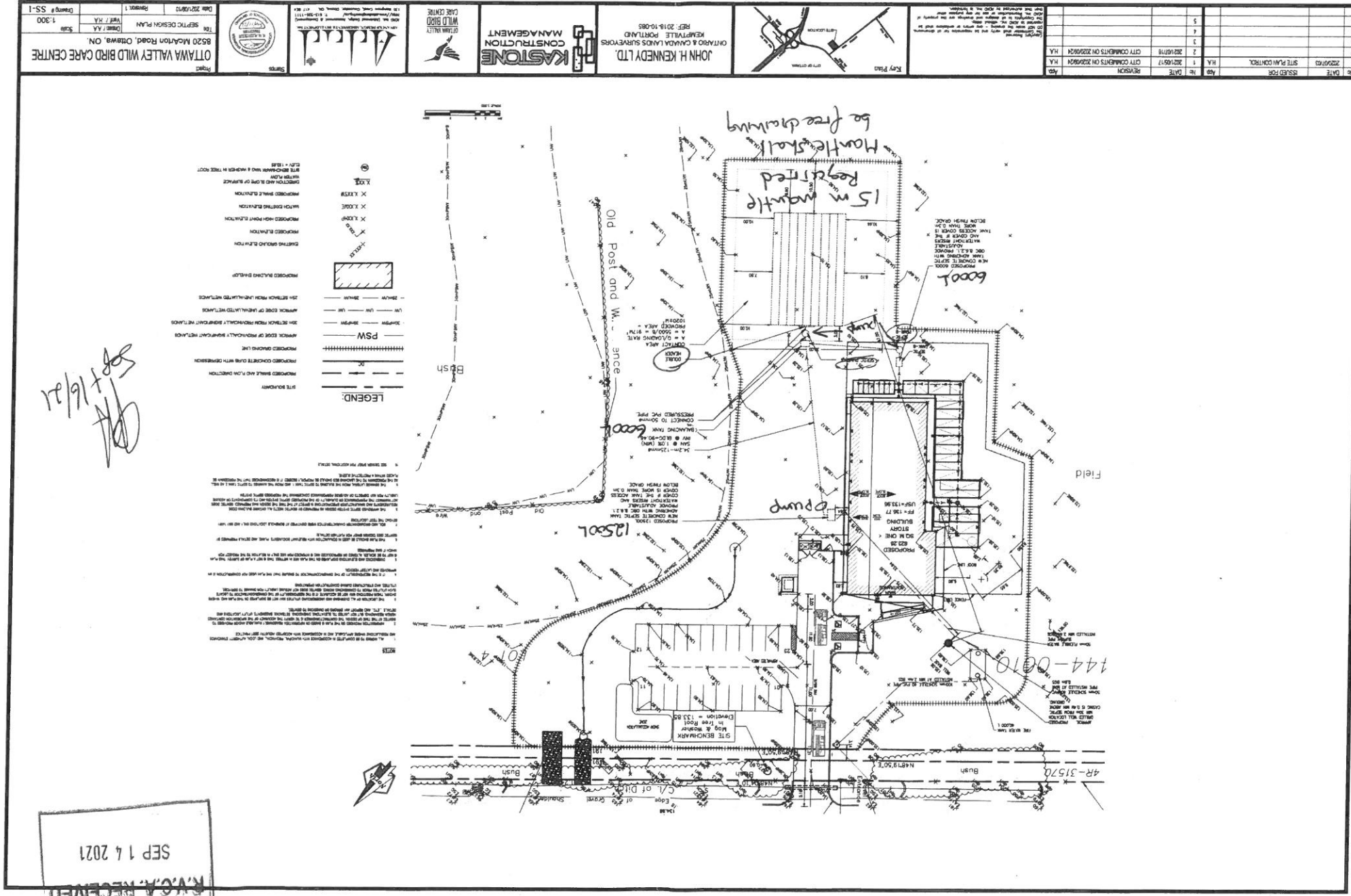

R.V.O.A. RECEIVED  
 SEP 14 2021

SEPTIC FILE #  
 21-558  
 OTTAWA

NO.	DATE	ISSUED FOR	BY	REVISION
1	2021/07/17	SITE PLAN CONTROL	H.A.	2021/07/17 CITY COMMENTS ON REVISION
2	2021/07/18		H.A.	
3			H.A.	
4			H.A.	
5			H.A.	

Project: OTTAWA VALLEY WILD BIRD CARE CENTRE  
 8520 McATION Road, OTTAWA, ON.  
 Scale: 1:300  
 Drawing: SS-1

Client: OTTAWA VALLEY WILD BIRD CARE CENTRE  
 Designer: JOHN H. KENNEDY LTD.  
 Project: 2018-10-08  
 Ontario & Canada Land Surveyors  
 Registration No. 2018-10-08

Contractor: KASTONE CONSTRUCTION MANAGEMENT  
 Consultant: Advanced Design, Assessment & Development Inc.

Figure B-1: Septic System Design Plan



# Permit

## Part 8 – Sewage System Ontario Building Code

Do Not Complete  
 Permit No 21-558  
 Revision No \_\_\_\_\_  
 Date \_\_\_\_\_  
 Related Application \_\_\_\_\_

**A copy of this permit must be posted on the property at all time during construction. OBC, Division C — Part 1, Section 1.3.2.1**  
 This permit verifies that the on-site sewage system was reviewed and approved for construction under the *Ontario Building Code* and *O.Reg. 323/12* as amended by *O.Reg. 151/13*.

Inspected & Recommended by: Ryan Hiemstra & Jason Hutton Owner: Ottawa Valley Wild Bird Care Centre  
 Inspection Date & Time: Nov 2, 2021 Weather: \_\_\_\_\_  
 Civic Address: 8520 McArton Road Legal: Plan 4R-31570, Part 1

number of bedrooms: \_\_\_\_\_ fixture units: \_\_\_\_\_  
 finished floor area: \_\_\_\_\_ Q: 5500 L/day

septic tank 12500 & 6000 L weigh bills for  yes  no  
 effluent filter YES grain size analysis required  yes  no  
 pump rate \_\_\_\_\_ timer dosed L/15 min site to be scarified  yes  no  
 treatment unit \_\_\_\_\_ clay seal inspection  yes  no  
 number of units \_\_\_\_\_ mantle required  yes  no  
 \_\_\_\_\_ sub-grade inspection  yes  no

ELEVATION  In Ground  Partially Raised  Fully Raised

**TYPE OF SYSTEM**

Trench  Shallow Buried Trench  
 Pipe and Stone or  Chambers pipe length \_\_\_\_\_ m 224  
 type of chamber \_\_\_\_\_ orifice spacing \_\_\_\_\_ m 0.6  
 loading area \_\_\_\_\_ m<sup>2</sup>  Filter Media Bed  
 total trench length \_\_\_\_\_ m stone \_\_\_\_\_ m<sup>2</sup>  
 trench configuration \_\_\_\_\_ extended base \_\_\_\_\_ m<sup>2</sup>  
 Dispersal Bed pipe \_\_\_\_\_  
 BMEC  Type A  Type B weight of filter media \_\_\_\_\_ kg  
 stone \_\_\_\_\_ m<sup>2</sup> loading area \_\_\_\_\_ m<sup>2</sup>  
 sand \_\_\_\_\_ m<sup>2</sup>  Class 5 Holding Tank  
 pipe \_\_\_\_\_  Septic Tank Only  
 linear loading \_\_\_\_\_ L/m<sup>2</sup>

Manager, Septic System Approvals: *Angela Randzio* Permit Date: NOVEMBER 3 2021  
 Comments: 1. OSSO to inspect subgrade prior to placing sandfill.  
 maintenance/pumping required  ESA permit # required  engineer to verify  
 Class 5 Holding Tank approval only valid for three years from date of issue  subgrade  
 squirt height  
 Manager, Septic System Approvals: \_\_\_\_\_ Revision Date: \_\_\_\_\_  
 Comments: \_\_\_\_\_  
 \_\_\_\_\_  
 \_\_\_\_\_

NOTE: For further details, refer to corresponding application.