

- LEGEND:
- EXISTING PLANT MATERIAL
  - PROPOSED PLANTINGS
  - PLANTING KEYS
  - SODDED AREAS
  - BIKE RACKS
  - SPA APPROVED

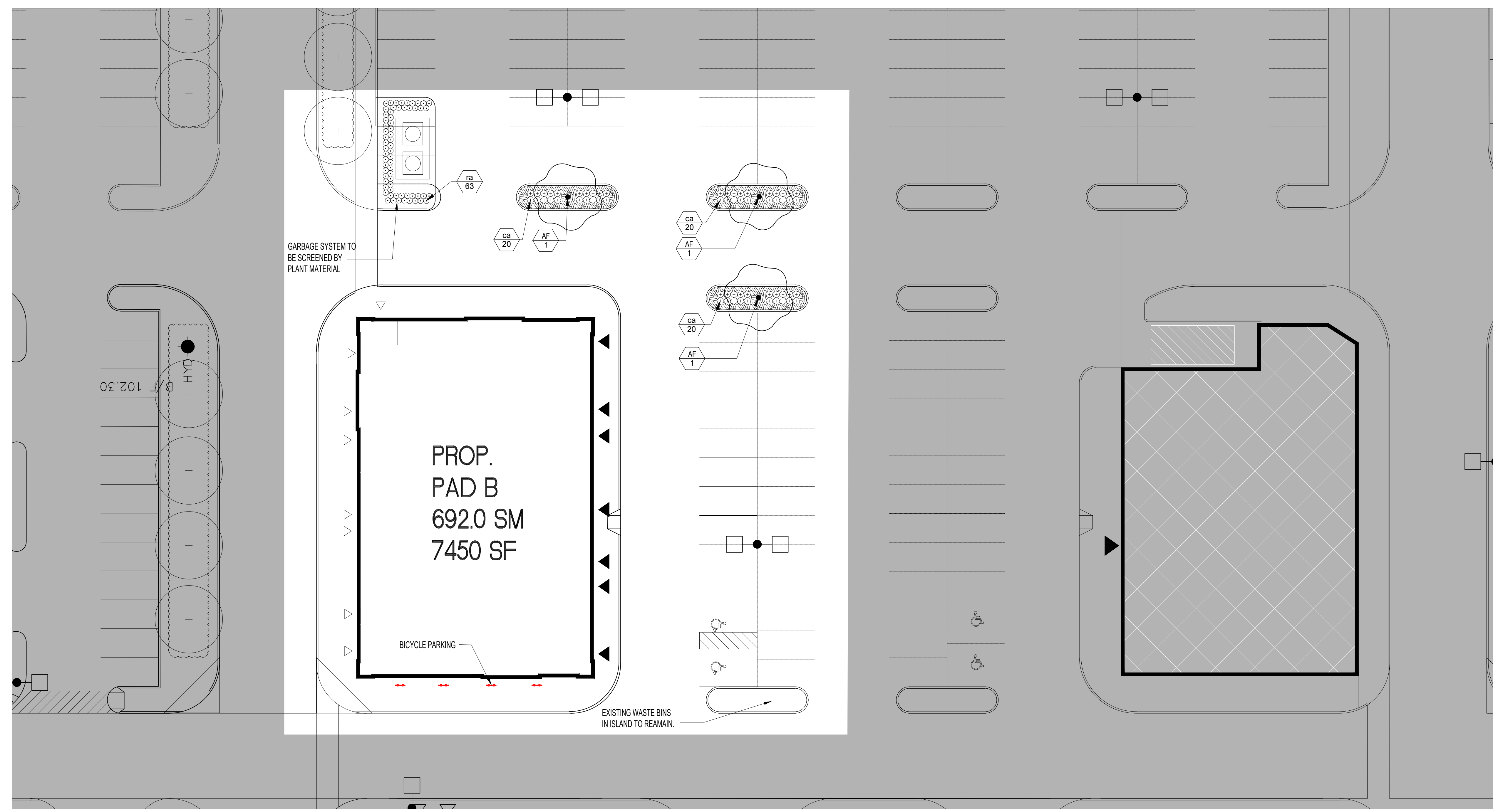

no.	revision	date	by
03	RE-ISSUED FOR SPA #3	2020-03-27	MC
02	RE-ISSUED FOR SPA	2019-12-29	MC
01	ISSUED FOR REVIEW	2019-09-10	MC

CONTRACTOR MUST VERIFY ALL DIMENSIONS ON THE JOB AND REPORT ANY DISCREPANCY TO THE LANDSCAPE ARCHITECT BEFORE PROCEEDING WITH THE WORK.  
 ALL DRAWINGS AND SPECIFICATIONS ARE INSTRUMENTS OF SERVICE AND THE PROPERTY OF THE LANDSCAPE ARCHITECT WHICH MUST BE RETURNED AT THE COMPLETION OF THE WORK.  
 ALL DRAWINGS TO BE USED FOR CONSTRUCTION ONLY WHEN SIGNED BY THE LANDSCAPE ARCHITECT.

signed \_\_\_\_\_ date \_\_\_\_\_

**terraplan**  
 LANDSCAPE ARCHITECTS  
 VISION. DELIVERED.

20 Champlain Blvd. Suite 102 - Toronto ON - M5H 2Z1 info@terraplan.ca www.terraplan.ca

**NORTH AMERICAN PROPERTIES**

CLIENT  
 COMMUNITY RETAIL DEVELOPMENT  
 5705 HAZELDEAN ROAD  
 WEST KANATA, ONTARIO

PROJECT  
 PROPOSED PAD 'B' LANDSCAPE PLAN

DRAWING  
 DRAWN: MC  
 CHECKED: DJ  
 SCALE: AS SHOWN  
 DATE: 2019-09-04  
 PROJECT NO.: 19-119



LP-102

*Colette Gorni*  
**COLETTE GORNI**  
 PLANNER I  
 PLANNING, INFRASTRUCTURE & ECONOMIC  
 DEVELOPMENT DEPARTMENT, CITY OF OTTAWA

**APPROVED**  
 By Colette Gorni at 9:27 am, Aug 10, 2020

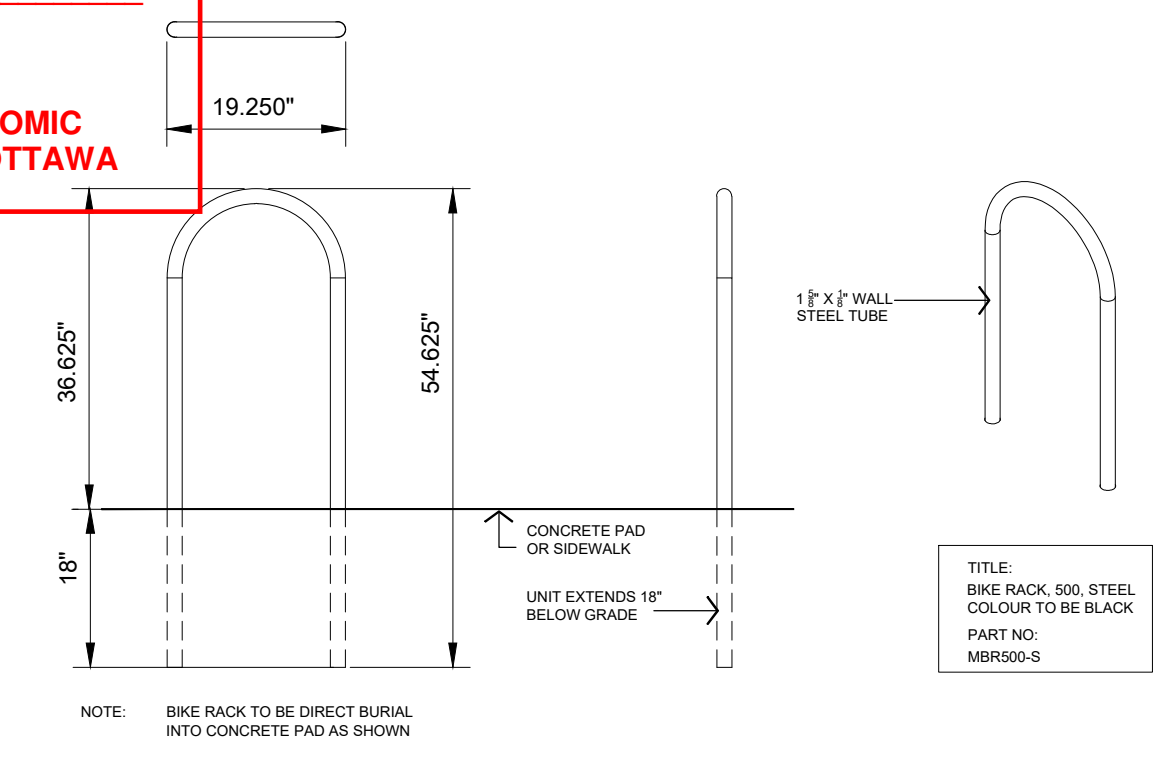

**MAGLIN**  
 MAGLIN SITE FURNITURE INC.  
 WWW.MAGLIN.COM  
 TEL: 800-716-0509  
 FAX: 877-260-8993

**1** TYP. BIKE RACK  
 1:20

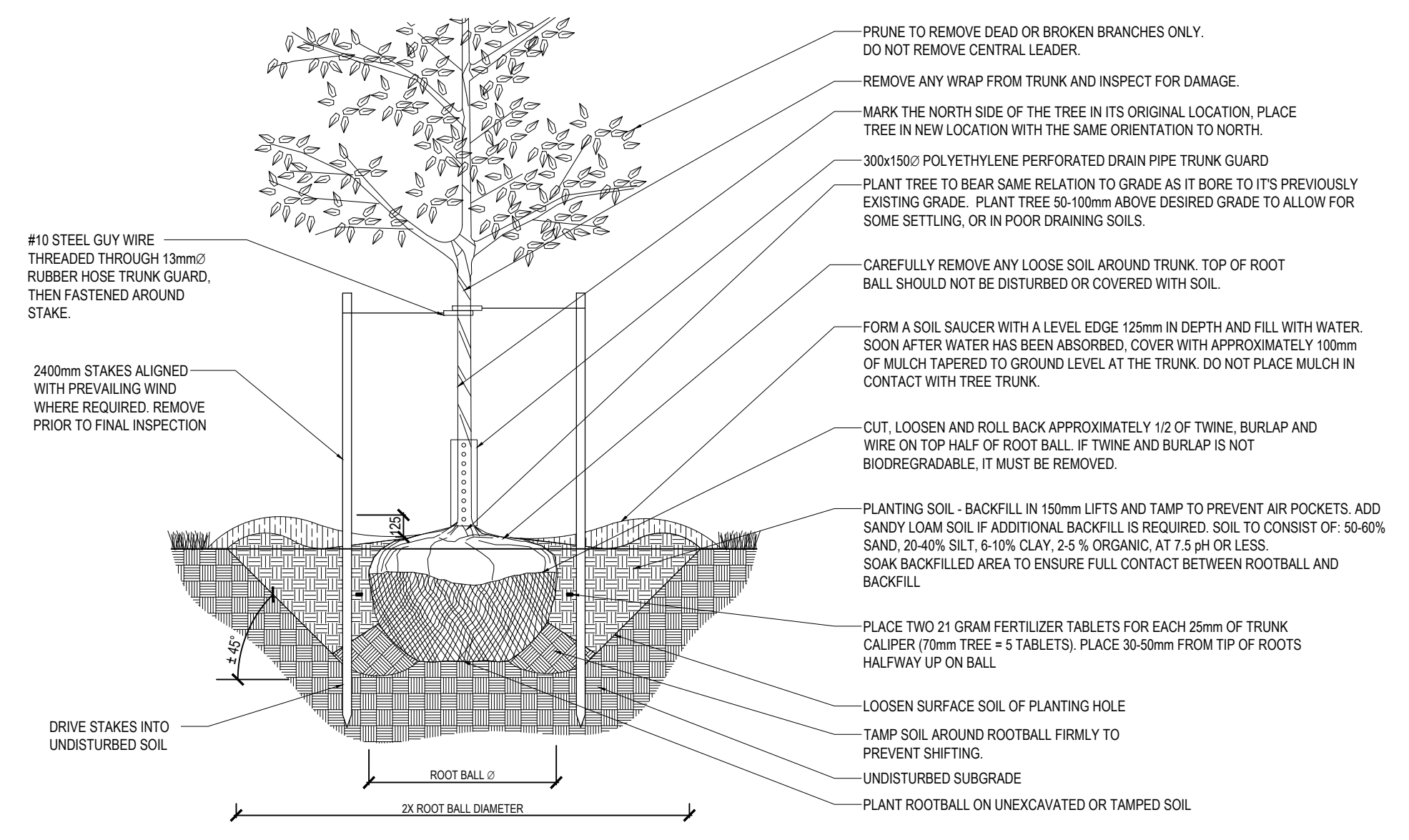

**2** STAKED B&B DECIDUOUS TREE INSTALLATION DETAIL  
 SCALE=NO SCALE

**FOR PLANT LIST, REFER TO SHEET LP-101**

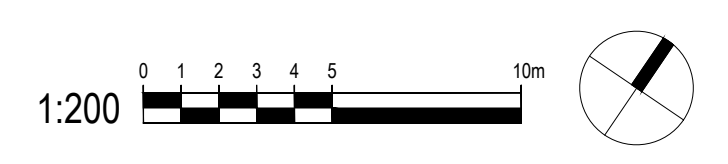

PROPOSED PAD 'B' LANDSCAPE PLAN  
 1:200 (LP-102)