



**Transportation Impact  
Assessment Report  
2 Via Modugno Place**

**PARSONS**





# 2 Via Modugno Place

## TIA Report

prepared for:  
Campanale Homes  
1187 Bank Street, Suite 200  
Ottawa, ON, K1S 3X7

prepared by:  
**PARSONS**  
1223 Michael Street North  
Suite 100  
Ottawa, ON K1J 7T2

October 11, 2019

477167 - 01000

# Document Control Page

---

<b>CLIENT:</b>	Campanale Homes
<b>PROJECT NAME:</b>	Transportation Impact Assessment – 2 Via Modugno Place
<b>REPORT TITLE:</b>	2 Via Modugno Place – TIA Report
<b>PARSONS PROJECT NO.:</b>	477167 – 01000
<b>VERSION:</b>	Final
<b>DIGITAL MASTER:</b>	H:\ISO\477167\1000\DOCS\STEP 5 - TIA Report\Strategy Report_2 Via Modugno PI_10.07.2019.docx
<b>ORIGINATOR</b>	Basel Ansari/Rani Nahas
<b>REVIEWER:</b>	Mark Baker
<b>AUTHORIZATION:</b>	City of Ottawa
<b>CIRCULATION LIST:</b>	Rosanna Baggs
<b>HISTORY:</b>	TIA Step 1 Screening Form – Submitted June 7, 2019 TIA Step 2 Scoping Report – Submitted June 27, 2019 TIA Step 3 Forecasting Report – Submitted July 8, 2019 TIA Step 4 Strategy Report – Submitted Sep 10, 2019 TIA Step 5 Report – Submitted Oct 11, 2019



## **TIA Plan Reports**

On 14 June 2017, the Council of the City of Ottawa adopted new Transportation Impact Assessment (TIA) Guidelines. In adopting the guidelines, Council established a requirement for those preparing and delivering transportation impact assessments and reports to sign a letter of certification.

Individuals submitting TIA reports will be responsible for all aspects of development-related transportation assessment and reporting, and undertaking such work, in accordance and compliance with the City of Ottawa's Official Plan, the Transportation Master Plan and the Transportation Impact Assessment (2017) Guidelines.

By submitting the attached TIA report (and any associated documents) and signing this document, the individual acknowledges that s/he meets the four criteria listed below.

### **CERTIFICATION**

1. I have reviewed and have a sound understanding of the objectives, needs and requirements of the City of Ottawa's Official Plan, Transportation Master Plan and the Transportation Impact Assessment (2017) Guidelines;
2. I have a sound knowledge of industry standard practice with respect to the preparation of transportation impact assessment reports, including multi modal level of service review;
3. I have substantial experience (more than 5 years) in undertaking and delivering transportation impact studies (analysis, reporting and geometric design) with strong background knowledge in transportation planning, engineering or traffic operations; and
4. I am either a licensed<sup>1</sup> or registered<sup>2</sup> professional in good standing, whose field of expertise [check  appropriate field(s)] is either transportation engineering  or transportation planning .

**1,2 License of registration body that oversees the profession is required to have a code of conduct and ethics guidelines that will ensure appropriate conduct and representation for transportation planning and/or transportation engineering works.**

City Of Ottawa  
Infrastructure Services and Community  
Sustainability  
Planning and Growth Management  
110 Laurier Avenue West, 4th fl.  
Ottawa, ON K1P 1J1  
Tel. : 613-580-2424  
Fax: 613-560-6006

Ville d'Ottawa  
Services d'infrastructure et Viabilité des  
collectivités  
Urbanisme et Gestion de la croissance  
110, avenue Laurier Ouest  
Ottawa (Ontario) K1P 1J1  
Tél. : 613-580-2424  
Télécopieur: 613-560-6006



Dated at Ottawa this 11 day of October, 2019.  
(City)

Name: Mark Baker  
(Please Print)

Professional Title: Senior Project Manager

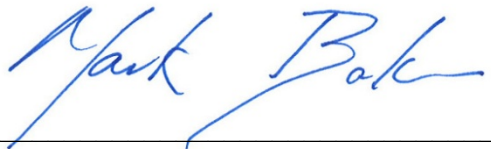
  
\_\_\_\_\_  
Signature of Individual certifier that s/he meets the above four criteria

<b>Office Contact Information (Please Print)</b>
Address: 1223 Michael Street, Suite 100
City / Postal Code: Ottawa K1J 7T2
Telephone / Extension: 613-691-1524
E-Mail Address: Mark.Baker@Parsons.com

Stamp

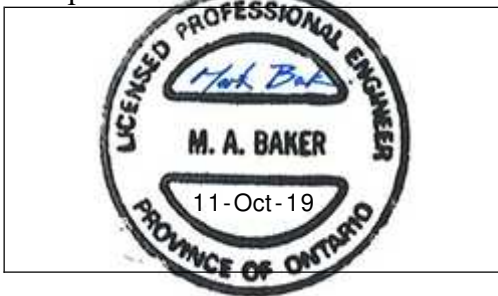

# Table of Contents

---

1.	SCREENING FORM.....	1
2.	SCOPING REPORT.....	1
2.1.	EXISTING AND PLANNED CONDITIONS.....	1
2.1.1.	Proposed Development .....	1
2.1.2.	Existing Conditions.....	3
2.1.3.	Planned Conditions.....	6
2.2.	STUDY AREA AND TIME PERIODS .....	7
2.3.	EXEMPTION REVIEW .....	8
3.	FORECASTING.....	9
3.1.	DEVELOPMENT GENERATED TRAVEL DEMAND.....	9
3.2.	BACKGROUND NETWORK TRAFFIC .....	9
3.2.1.	Transportation Network Plans.....	9
3.2.2.	Background Growth .....	9
3.2.3.	Other Developments.....	10
3.2.4.	Total background traffic.....	11
3.3.	DEMAND RATIONALIZATION .....	12
4.	ANALYSIS .....	13
4.1.	DEVELOPMENT DESIGN .....	13
4.1.1.	Design for Sustainable Modes .....	13
4.1.2.	Circulation and Access.....	13
4.2.	PARKING.....	13
4.2.1.	Parking Supply.....	13
4.3.	BOUNDARY STREET DESIGN .....	13
4.4.	ACCESS INTERSECTION DESIGN.....	14
4.4.1.	Location and Design of Access .....	14
4.4.2.	Intersection Control .....	14
4.4.3.	Intersection Design.....	14
4.5.	TRANSPORTATION DEMAND MANAGEMENT .....	15
4.6.	NEIGHBOURHOOD TRAFFIC MANAGEMENT.....	16
4.7.	TRANSIT.....	16
4.8.	REVIEW OF NETWORK CONCEPT .....	16
4.9.	INTERSECTION DESIGN .....	16
5.	FINDINGS, CONCLUSIONS AND RECOMMENDATIONS.....	16

## List of Figures

Figure 1: Local Context .....	1
Figure 2: Proposed Site Plan .....	2

Figure 3: Area Transit Network..... 5  
 Figure 4: Bus Stop Locations..... 5  
 Figure 5: Existing Peak Hour Traffic Volumes..... 5  
 Figure 6: Other Area Developments ..... 6  
 Figure 7: Study Area..... 8  
 Figure 8: Future Background 2020..... 9  
 Figure 9: Future Background 2025..... 10  
 Figure 10: Other Area Developments Traffic Volumes..... 10  
 Figure 11: 619 Longfields Dr anticipated Traffic Volumes ..... 11  
 Figure 12: Total Future Background 2020 Traffic Volumes ..... 12  
 Figure 13: Total Future Background 2025 Traffic Volumes ..... 12

**List of Tables**

Table 1: Exemptions Review Summary..... 8  
 Table 2: Annual Background Growth Rate..... 9  
 Table 3: 619 Longfields Dr Vehicle Trips Generated ..... 11  
 Table 4: MMLoS – Boundary Road Analysis ..... 14  
 Table 5: Existing Conditions Intersection Performance ..... 15  
 Table 6: Total Future Background 2020 Intersection Performance ..... 15  
 Table 7: Total Future Background 2025 Intersection Performance ..... 15

**List of Appendices**

APPENDIX A – Screening Form  
 APPENDIX B – Truck Turning Templates  
 APPENDIX C – OC Transpo Route Maps  
 APPENDIX D – Traffic Counts  
 APPENDIX E – Collision Data  
 APPENDIX F – 619 Longfields Dr Site Plan  
 APPENDIX G – Trip Generation Calculations  
 APPENDIX H – Detailed Background Growth Analysis  
 APPENDIX I – Stopping Sight Distances  
 APPENDIX J – MMLoS Analysis  
 APPENDIX K – Synchro Analysis: Existing Conditions  
 APPENDIX L – Synchro Analysis: Total Future Background 2020 Conditions  
 APPENDIX M – Synchro Analysis: Total Future Background 2025 Conditions



# TIA Report

## 1. SCREENING FORM

The screening form was completed for the subject development and included as part of the subsequent report. The Trip Generation, Location and Safety triggers were all checked against their respective criteria and it was determined that only the Location trigger is met. Since at least one of the triggers was met, a Transportation Impact Assessment (TIA) report must be completed based on the City of Ottawa’s 2017 TIA Guidelines. The screening form, as well as responses to latest City comments, are provided in **Appendix A**.

## 2. SCOPING REPORT

### 2.1. EXISTING AND PLANNED CONDITIONS

#### 2.1.1. PROPOSED DEVELOPMENT

This study has been prepared as part of a Site Plan Application (SPA) of a proposed residential development taking place at 2 Via Modugno Pl, within Ward 3 (Barrhaven). Furthermore, this development forms part of the Campanale Homes’ Longfields Station development lands in Barrhaven. The development site is zoned as a Mixed-Use Centre. **Figure 1** provides area context regarding the location of the planned future development and the surrounding road network.

Figure 1: Local Context



The residential development is expected to consist of 28 low-rise apartment units and approximately 15,000 ft<sup>2</sup> of commercial space and is anticipated to be constructed in a single phase by 2020. Parking spaces will be provided in the form of surface parking with a total of 55 spaces, which included two accessible and six visitor parking spaces. **Figure 2** shows the proposed site plan of the proposed future development.



As illustrated by the Site Plan, the following accesses will serve the site as a connection to the surrounding road network:

- One access will be located along Via Modugno Pl, on the east side of the site, and will be restricted to inbound traffic only.
- The second access will be located along Via Campanale Ave, on the north side of the site, as a full-movement driveway.
- The third access will also be located along Via Campanale Ave, on the west side of the site, as a full-movement driveway. It should be noted that there is a slight offset between the third access and the existing Via Chianti Grove connection to Via Campanale Ave.

Garbage trucks are expected to enter through the west Via Campanale access and exit through the north Via Campanale access. Truck turning templates have been provided in **Appendix B**.

## 2.1.2. EXISTING CONDITIONS

---

### Area Road Network

**Longfields Dr** is a municipal roadway in Barrhaven that extends from Bill Leathem Dr in the east to Jockvale Rd in the south. Between Bill Leathem Dr and Strandherd Dr, Longfields Dr is classified as a major collector roadway, with a two-lane cross-section. Whereas between Strandherd Dr and Jockvale Rd, it is classified as an arterial roadway, with a four-lane cross-section. Furthermore, auxiliary turn lanes are provided at major intersections. The posted speed limit of Longfields Dr within the study area is 40 km/h.

**Via Modugno Pl** is a local municipal roadway in Barrhaven with a two-lane cross-section and on-street parking on both sides of the road. The roadway extends from Longfields Dr to Via Campanale Ave and is assumed to have a speed limit of 40 km/h.

**Via Campanale Ave** is a local municipal roadway in Barrhaven with a two-lane cross-section that extends from Via Mattino Way in the north to Longfields Dr in the east. The assumed speed limit of the roadway is 40 km/h.

### Existing Study Area Intersections

#### Longfields/Via Modugno Pl

The Longfields/Via Modugno Pl intersection is a 'T' intersection with signal control on the Longfields Dr approaches (north/south legs) and STOP control on the Via Modugno Pl approach (west leg). All legs of the intersection consist of an unrestricted single, full-movement lane. The traffic signal provided is a pedestrian signal, that allows pedestrians to cross at the north leg of the intersection.

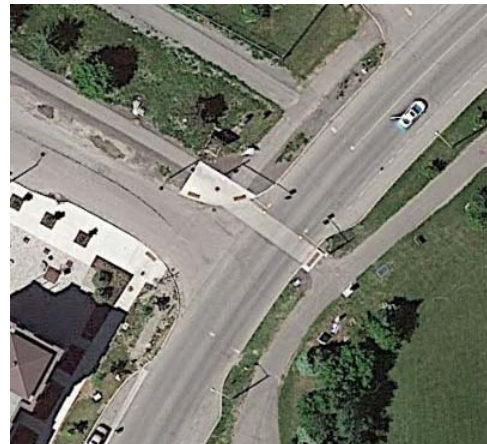



# PARSONS

## Longfields/Via Campanale Ave

The Longfields/Via Campanale Ave intersection is an unsignalized 'T' intersection with STOP control on the minor leg of the intersection. All legs of the intersection consist of an unrestricted single, full-movement lane. Pedestrians will be able to cross the intersection at the west leg only.



## Existing Driveways to Adjacent Developments

Within 200 m of the proposed site accesses are several existing driveways along Via Campanale Ave. Two driveways serve the adjacent developments located at the municipal addresses 615 and 619 Longfields Dr. A few other driveways further down Via Campanale Ave are used by private residential house units. Furthermore, the proposed third access of the development will be located across from the Via Chianti Grove roadway.

## Pedestrian/Cycling Network

With regards to pedestrians, sidewalk facilities and pathways are provided throughout Longfields Dr and along developed areas of Via Modugno Pl and Via Campanale Ave. A major pathway runs alongside the transitway, directly west of the development site. The major pathway also connects to other pathways that run along several sections of Longfields Dr and converge with the existing sidewalk facilities.

With regards to cyclists, on-road bicycle lanes are provided on Longfields Dr, along some sections of the roadway. Where on-street parking is provided, the bicycle lanes are not present.

## Transit Network and Bus Services

The following OC Transpo bus routes operate within or near the study area:

- **Route #171 (Fallowfield <-> Barrhaven Centre):** identified by OC Transpo as a "Local Route", this route operates at a rate of every 30 minutes during weekday morning and afternoon peak hour periods. The nearest bus stop to the future development site is at the intersection of Longfields/Mountshannon.
- **Route #95 (Orleans & Trim <-> Cambrian):** identified by OC Transpo as a "Rapid Route", this route operates along the transitway and stops at Longfields Station, located approximately 100 m west of the development site. Route #95 operates 7 days a week at a very rapid rate.
- **Routes #271, #273 and #275** are identified as "Connexion Routes" that operate during weekday rush-hours only, at a rate of every 30 minutes. These routes run along the transitway and stop at Longfields Station.

The noted OC Transpo route maps are provided in **Appendix C. Figure 3** below illustrates the area transit network as portrayed in the OC Transpo System Map, while **Figure 4** provides the locations of bus stops nearest to the site.

Figure 3: Area Transit Network



Figure 4: Bus Stop Locations

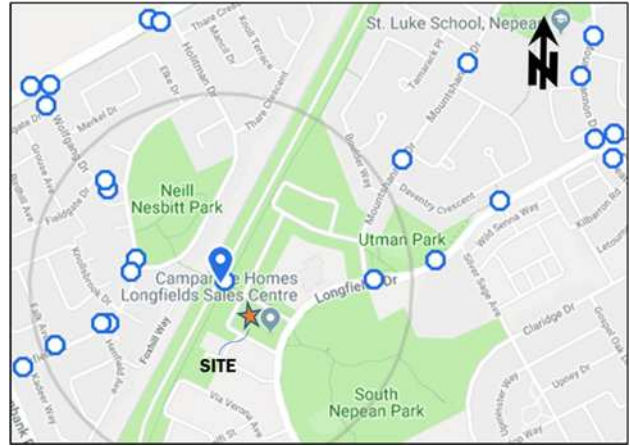

**Existing Area Traffic Management**

Some of the existing area traffic management measures within the study area include the following:

- Sidewalk facilities;
- Bike lanes;
- On-street parking;
- Streetscaping

**Peak hour travel demands**

In order to establish a baseline for local traffic conditions, traffic counts were conducted by Parsons in June 2019 for the following intersections:

- Longfields Dr/Via Modugno Pl
- Longfields Dr/Via Campanale Ave

Figure 5 provides an illustration of the existing traffic volumes at intersections within the study area. All traffic count data is provided in Appendix D.

Figure 5: Existing Peak Hour Traffic Volumes

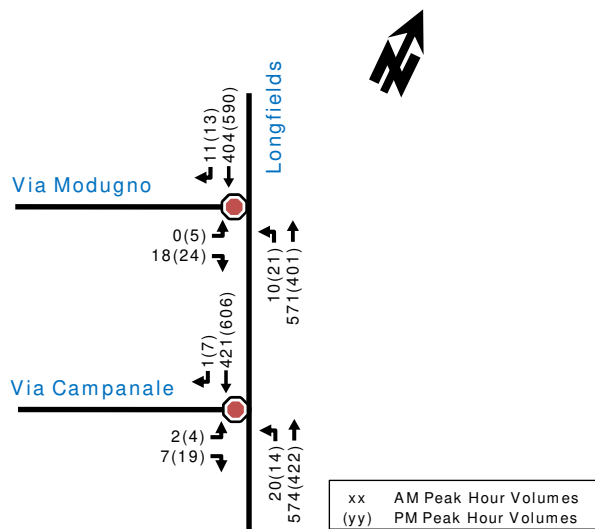

## Existing Road Safety Conditions

A five-year (2014-2018, inclusive) collision history report was requested and obtained from the City of Ottawa (provided in **Appendix E**) for the following intersections and road segments:

- Longfields Dr/Via Modugno PI
- Longfields Dr/Via Campanale Ave
- Longfields Dr between Via Modugno PI and Campanale Ave

The collision data collected revealed that only two collisions have taken place at the above locations, within the past five-years. One collision occurred at the intersection of Longfields/Via Campanale in May 2015 and resulted in a non-fatal injury, while the second collision occurred at the intersection of Longfields/Via Modugno in June 2017 and resulted in property damage only. Based on the foregoing, there is no evidence of a systemic safety issue.

### 2.1.3. PLANNED CONDITIONS

#### Planned Study Area Transportation Network Changes

According to the “2031 Affordable Network” (Map 11), 2015 revision, of the City of Ottawa’s Transportation Master Plan, there are no notable transportation network changes planned within the study area by 2031. There are also no anticipated transit network changes.

#### Other Area Developments

Development applications for adjacent area developments located within 1 km of the proposed Campanale Homes development site were researched using the City of Ottawa’s “In My Neighbourhood” tool. Descriptions of other area developments are provided below.

#### Campanale Homes

As previously mentioned, the subject development forms part of the Campanale Homes’ Longfields Station development lands in Barrhaven. To illustrate the plan for the Longfields Station development lands, **Figure 6** was taken from the Campanale Homes website and was overlaid with the subject site’s location.

Figure 6: Other Area Developments





# PARSONS

A site visit to the study area revealed that, with the exception of the fully constructed building immediately south of the development site, all surrounding developments (represented by orange and red blocks) are either under construction or have yet to be constructed. Development applications for the following Campanale Homes developments were found:

- 605 Longfields Dr: illustrated in **Figure 6** by the “L” shaped block directly east of the development site, this development is currently under construction and is anticipated to consist of minor commercial uses. A TIA report was submitted by Parsons in December 2017, which determined that the development is expected to generate approximately 28 and 40 veh/h during the weekday morning and afternoon peak hour periods, respectively.
- 619 Longfields Dr: illustrated in **Figure 6** by the five orange blocks immediately west of the development site, this development has almost reached full buildout. Based on its site plan (see **Appendix F**), this development consists of a total of 64 residential units housed within five mid-rise apartment buildings. Trips generated by this development will be manually calculated and assigned to the road network in **Section 3.2.3** of the report.

As such, the other area developments above will be included in the future background traffic volumes forecasted in this report. The remaining Campanale Homes developments that are located north of the development site and southwest of the 619 Longfields Dr development site are excluded due to uncertainty with regards to their use, size and status.

### 255 and 285 Mountshannon Dr

A 16-unit and 20-unit stacked dwellings are planned to be constructed at 255 and 285 Mountshannon Dr, respectively. This development is anticipated to generate minimal traffic. As such, it will be accounted for in the background growth rate determined in **Section 3.2.2**.

### 146 Mountshannon Dr

A residential development consisting of 22 townhomes and 160 condominium units are planned to be distributed in 9 low-rise apartment buildings at 146 Mountshannon Dr. Due to its proximity to the proposed Campanale Homes development site, traffic volumes generated by this development along Longfields Dr will be accounted for in the background growth rate determined in **Section 3.2.2**.

### 35 Highbury Park Dr

A development consisting of a church and accompanying café are planned at the above noted address. Due to its proximity to the proposed Campanale Homes development site, traffic volumes generated by this development along Longfields Dr will be accounted for in the background growth rate determined in **Section 3.2.2**

### 30 Highbury Park Dr

A development consisting of retail, a fast-food restaurant, a medical office, and a pharmacy are planned at the above noted address. Due to its proximity to the proposed Campanale Homes development site, traffic volumes generated by this development along Longfields Dr will be accounted for in the background growth rate determined in **Section 3.2.2**

## 2.2. STUDY AREA AND TIME PERIODS

---

The proposed study area intersections to be included in the analysis are outlined below and illustrated in **Figure 7**.

- Longfields Dr/Via Modugno Pl
- Longfields Dr/Via Campanale Ave

Figure 7: Study Area



Since the development consists of residential units, the critical time periods where the site-generated traffic volumes are expected to reach their peak is during the weekday morning and afternoon peak hour periods. This coincides with the peak periods of the background traffic of the road network. As such, operational analysis in this report will rely on these two peak time periods.

The TIA guidelines require that two horizon years be analyzed; those are the anticipated year of full build-out of the development (i.e. 2020) and five years after full build-out (i.e. 2025).

### 2.3. EXEMPTION REVIEW

Based on the City’s TIA guidelines and the subject site, the following modules/elements of the TIA process, summarized in **Table 1**, are recommended to be exempt in the subsequent steps of the TIA process:

Table 1: Exemptions Review Summary

Module	Element	Exemption Consideration
3.1 Development Generated Travel Demand	All elements	Not required if Trip Generation trigger is not met (i.e. development does not generate more than 60 trips/h during peak hours).
4.1 Development Design	4.1.3 New Street Networks	Not required for applications involving site plans.
4.2 Parking	4.2.2 Spillover Parking	The parking is expected to meet By-Law requirements.
4.5 – 4.9 Network Impact Component	All elements	Not required if Trip Generation trigger is not met (i.e. development does not generate more than 60 trips/h during peak hours).

Summary of the trip generation calculations has been provided in **Appendix G**.

### 3. FORECASTING

#### 3.1. DEVELOPMENT GENERATED TRAVEL DEMAND

Exempt – see Section 2.3.

#### 3.2. BACKGROUND NETWORK TRAFFIC

##### 3.2.1. TRANSPORTATION NETWORK PLANS

Refer to Section 2.1.3.

##### 3.2.2. BACKGROUND GROWTH

In order to determine a background growth rate along Longfields Dr, regression analysis was conducted using historical traffic counts (2012, 2013 and 2019) at the intersection of Longfields/Mountshannon, approximately 190 m east of the Longfields/Via Modugno PI intersection. **Table 2** below provides a summary of the background growth rates determined using the AM and PM peak traffic counts, where east and west legs represent the approaches along Longfields Dr. The detailed background growth analysis is provided in **Appendix H**.

Table 2: Annual Background Growth Rate

Time Period	Percent Annual Change	
	East Leg	West Leg
AM Peak	15.54%	11.55%
PM Peak	17.43%	9.38%

Based on the above, the average annual background growth rate is approximately 13.5% during both peak hours. However, this growth rate may be attributed to the construction of many new developments in the lands surrounding Longfields Dr in recent years, the majority of which consists of residential areas. As such, a background growth rate of 13.5% is not considered sustainable and would not be an accurate assumption for future background conditions. To account for the developments that have yet to be constructed, a 5% per year increase in through traffic was applied along Longfields Dr. The resulting future background traffic volumes for horizon years 2020 and 2025 are illustrated in **Figure 8** and **Figure 9**.

Figure 8: Future Background 2020

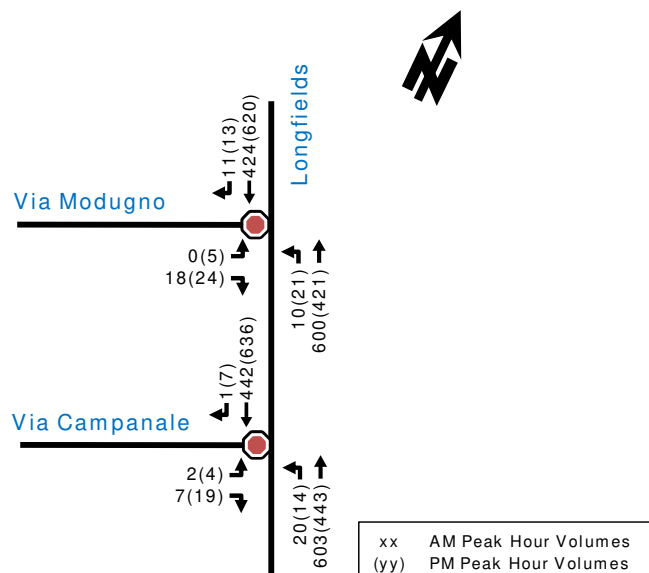
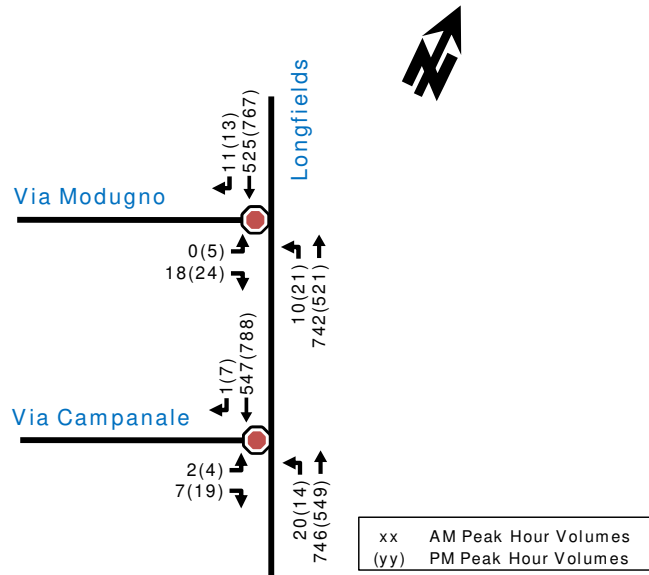

Figure 9: Future Background 2025



**3.2.3. OTHER DEVELOPMENTS**

Descriptions of adjacent developments in the surrounding area, that have initiated the development application process with the City, was provided in **Section 2.1.3: Other Area Developments**. Traffic volumes generated by the following future adjacent area developments will be included in the total future background traffic volumes of the study area:

**605 Longfields Dr**

Traffic volumes generated by the future development at 605 Longfields Dr are illustrated in **Figure 10**, which was taken directly from the TIA Report submitted by Parsons in December 2017. Note that the negative numbers refer to Pass-by traffic.

Figure 10: Other Area Developments Traffic Volumes

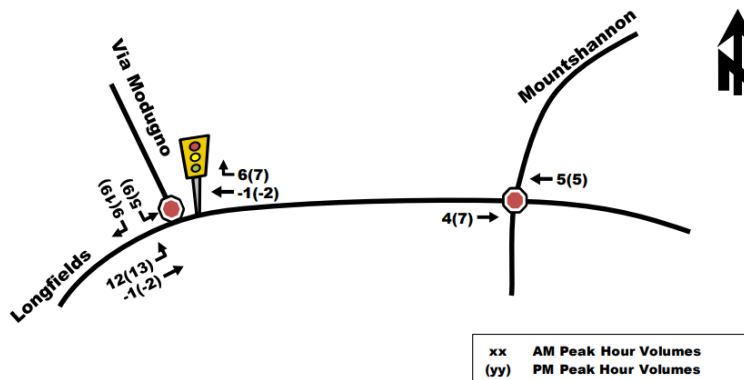

**619 Longfields Dr**

Using the 2009 TRANS Trip Generation Study Report, the trip rates, the percentage of inbound and outbound trips and the total person trips were determined for the development at 619 Longfields Dr. The total person trips were then separated into different travel modes, using the mode share percentages from the 2011 NCR Household Origin-Destination Survey (South Nepean District). **Table 3** provides the number of trips anticipated to be generated by auto vehicles during the morning and afternoon peak hour periods.

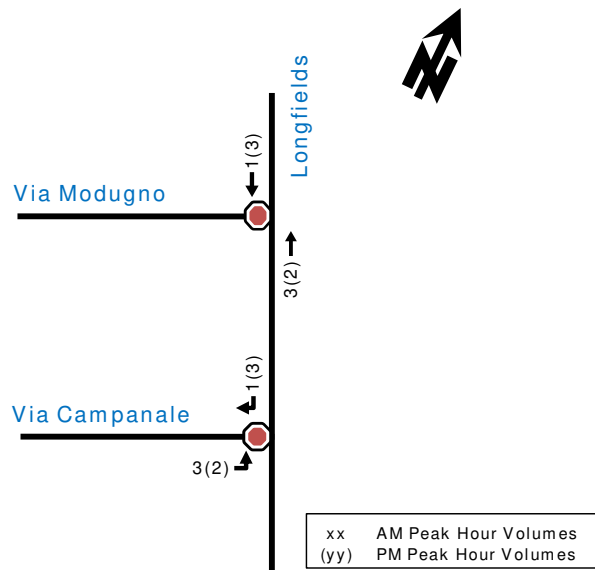

Table 3: 619 Longfields Dr Vehicle Trips Generated

Land Use	Data Source	Dwelling Units	AM Peak (veh/h)			PM Peak (veh/h)		
			In	Out	Total	In	Out	Total
			24%	76%		62%	38%	
Mid-rise apartments (4 floors)	TRANS	64 du	3	12	15	11	8	19

The total number of trips anticipated to be generated by the development at 619 Longfields Dr are 15 and 19 veh/h during the morning and afternoon peak hour periods, respectively. As shown in the site plan, there are two planned accesses to the development site. The majority of traffic generated by this development (75%) is expected to utilize the south access of the development site and arrive at the intersection of Longfields Dr/Via Chianti Grove, thus, it would not influence the study area intersections. The remaining traffic is assumed to use the west development access along Via Chianti Grove and arrive at the intersection of Longfields Dr/Via Campanale Ave. These volumes are shown in **Figure 11** below.

Figure 11: 619 Longfields Dr anticipated Traffic Volumes



**3.2.4. TOTAL BACKGROUND TRAFFIC**

Total background traffic represents the summation of background traffic growth (based on the 5% growth rate per annum) in each of **Figure 8** and **Figure 9**, with the adjacent development traffic in **Figure 10** and **Figure 11**. The resulting total background traffic volumes for horizon years 2020 and 2025 are illustrated in **Figure 12** and **Figure 13**.

Figure 12: Total Future Background 2020 Traffic Volumes

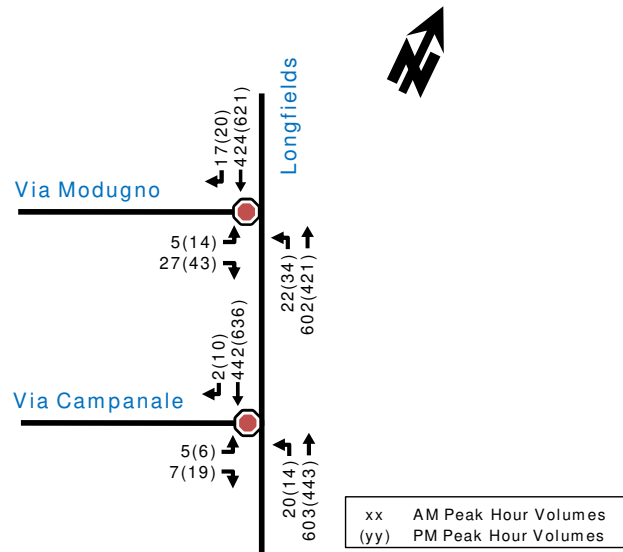
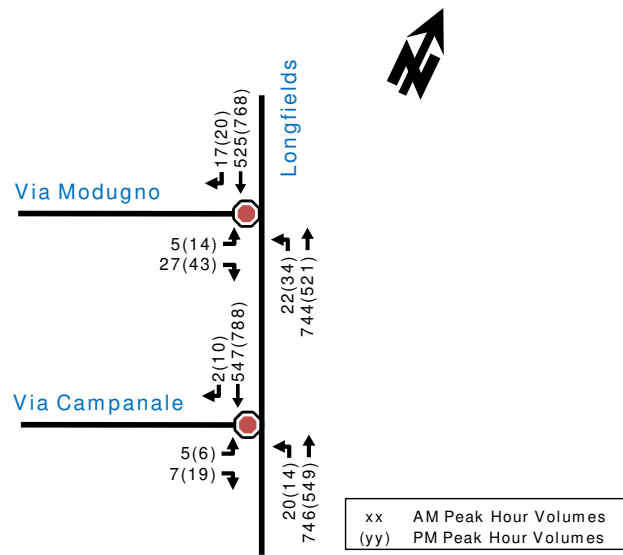

Figure 13: Total Future Background 2025 Traffic Volumes



### 3.3. DEMAND RATIONALIZATION

The study area road network is expected to accommodate projected volumes. There are currently no anticipated capacity issues. The capacity of the roadways will be further explored in a more detailed review of the total projected traffic volumes and intersection design in the ensuing Strategy Report.

## 4. ANALYSIS

### 4.1. DEVELOPMENT DESIGN

#### 4.1.1. DESIGN FOR SUSTAINABLE MODES

---

Pedestrians can access the development site through the series of sidewalks that are currently provided throughout the study area. Sidewalk facilities will also be provided along both sides of Via Campanale Ave and Via Modugno Pl. There are no plans currently for bike lanes however there is an existing MUP on the south side of Longfields Dr.

With regards to transit, six bus routes currently operate within vicinity of the site, as previously mentioned in **Section 2.1.2**. Furthermore, the nearest bus stop to the development site is Longfields BRT Station, within approximately 175m walking distance. Transit stops along Longfields Dr are located approximately 400 – 550m walking distance from the site.

#### 4.1.2. CIRCULATION AND ACCESS

---

There are three proposed accesses to the site: two all-movement accesses and an inbound-only access. According to the City's Private Approach By-law, the number of accesses and location are appropriate. **Section 4.4: Access Intersection Design** will go into further detail regarding the design, location, and control of these driveways.

The driveway aisle widths are noted to be 6.7 – 7.0m wide, meeting the minimum By-Law requirements. The single inbound entrance is noted to be 3.0m, also meeting minimum By-Law requirements. Stopping sight distances have been provided in **Appendix I**.

### 4.2. PARKING

#### 4.2.1. PARKING SUPPLY

---

##### *Vehicle Parking*

A total of 55 vehicle parking spaces will be provided for the planned development, with 3 spaces provided for visitors and 2 barrier free parking spaces (i.e. accessible parking). The number of parking spaces provided exceeds the minimum parking space rates set by the City of Ottawa parking provisions (11 spaces minimum). The parking spaces are 5.2 m long and 2.6 m wide.

##### *Bicycle Parking*

A total of 25 bicycle parking spaces are provided, exceeding the requirement set by the City of Ottawa's bike parking provisions. Furthermore, the bike parking is located outside, near the north end of the site.

### 4.3. BOUNDARY STREET DESIGN

---

The boundary streets of the development are Via Campanale Ave and Via Modugno Pl. As these streets are not fully built, a Multi-Modal Level of Service (MMLoS) analysis was conducted for all three boundary streets, based on future conditions.

#### Via Campanale Ave, West Frontage:

- 1 vehicle travel lane in each direction;
- 2.0 m sidewalks along the site frontage;
- Less than 3000 avg. daily curb lane traffic volumes; and,
- Approximately 3.5 m wide lanes.

#### Via Campanale Ave, North Frontage:

- 1 vehicle travel lane in each direction;
- 2.0 m sidewalks along the site frontage;
- Parking along the north side of the roadway;
- Less than 3000 avg. daily curb lane traffic volumes; and,
- Approximately 3.5 m wide lanes.

Via Modugno PI, East Frontage:

- 1 vehicle travel lane in each direction;
- 2.0 m sidewalks along the site frontage;
- Parking along both sides of the roadway;
- Less than 3000 avg. daily curb lane traffic volumes; and,
- Approximately 3.5 m wide lanes.

The multi-modal level of service analysis for the adjacent road segments is summarized in **Table 4**, with detailed analysis provided in **Appendix J**. The table also identifies the target LOS, with respect to each mode, based on the land-use designation and road classification of the development site and the boundary streets. The Transportation Master Plan (TMP) identifies the land-use designation of the development site as General Urban Area.

Table 4: MMLOS – Boundary Road Analysis

Road Segment	Level of Service							
	Pedestrian (PLOS)		Bicycle (BLOS)		Transit (TLOS)		Truck (TkLOS)	
	PLOS	Target	BLOS	Target	TLOS	Target	TkLOS	Target
Via Campanale (west frontage)	A	A	A	D	D	No target	B	No target
Via Campanale (north frontage)	A	A	A	D	D	No target	B	No target
Via Modugno	A	A	A	D	D	No target	B	No target

As shown in **Table 4**, all modes meet their respective level of service targets. Note that there are no targets for transit or trucks, as there are no transit facilities on boundary streets and the boundary streets do not make up part of the truck route network.

## 4.4. ACCESS INTERSECTION DESIGN

### 4.4.1. LOCATION AND DESIGN OF ACCESS

There are three proposed accesses to the site:

- West Access – This access is proposed as an all-movement access. It is located on Via Campanale Ave and forms the forth leg with Via Chianti Grove to the west;
- North Access – This access is proposed as an all-movement “T” access. It is located on Via Campanale Ave; and,
- East Access – This access is proposed as an in-bound only “T” access, located on Via Modugno PI.

### 4.4.2. INTERSECTION CONTROL

Based on the roadway design and projected vehicle volumes, the planned driveways would likely be proposed with STOP control on the minor approaches only.

### 4.4.3. INTERSECTION DESIGN

## EXISTING CONDITIONS

SYNCHRO (V10) Trafficware was used to analyze intersections within the study area. The following **Table 5** provides a summary of the existing traffic operations based on the existing peak hour traffic volumes (**Figure 5**). Critical movements



at study area intersections were identified based on the movement with the highest average delay. The SYNCHRO model output for existing conditions is provided in **Appendix K**.

Table 5: Existing Conditions Intersection Performance

Intersection	Weekday AM Peak (PM Peak)			
	Critical Movement			Intersection 'As a Whole'
	LOS	avg. delay (s)	Movement	Delay (s)
Longfields Dr/Via Modugno PI (U)	B(C)	11.4(16.0)	EB(EB)	0.4(0.8)
Longfields Dr/Via Campanale Ave (U)	B(C)	13.5(15.2)	EB(EB)	0.4(0.5)

Note: Analysis of signalized intersections assumes a PHF of 0.90 and a saturation flow rate of 1800 veh/h/lane.  
(U) - Unsignalized intersection.

As shown in **Table 5**, critical movements at both study area intersections operate at a LOS 'C' or better during the morning and afternoon peak hour periods.

## TOTAL FUTURE BACKGROUND 2020 CONDITIONS

**Table 6** below provides a summary of SYNCHRO analysis at study area intersections, based on total future background 2020 traffic volumes (**Figure 12**). The SYNCHRO model output for total future background 2020 conditions is provided in **Appendix L**.

Table 6: Total Future Background 2020 Intersection Performance

Intersection	Weekday AM Peak (PM Peak)			
	Critical Movement			Intersection 'As a Whole'
	LOS	avg. delay (s)	Movement	Delay (s)
Longfields Dr/Via Modugno PI (U)	B(C)	13.3(17.3)	EB(EB)	0.7(1.3)
Longfields Dr/Via Campanale Ave (U)	C(C)	15.3(15.4)	EB(EB)	0.5(0.5)

Note: Analysis of signalized intersections assumes a PHF of 1.0 and a saturation flow rate of 1800 veh/h/lane.  
(U) - Unsignalized intersection.

As shown in **Table 6** above, intersections in total future background 2020 conditions are projected to operate similar to existing conditions, with slightly higher delays for critical movements and the intersection 'as a whole'.

## TOTAL FUTURE BACKGROUND 2025 CONDITIONS

**Table 7** below provides a summary of SYNCHRO analysis at study area intersections, based on total future background 2025 traffic volumes (**Figure 13**). The SYNCHRO model output for total future background 2025 conditions is provided in **Appendix M**.

Table 7: Total Future Background 2025 Intersection Performance

Intersection	Weekday AM Peak (PM Peak)			
	Critical Movement			Intersection 'As a Whole'
	LOS	avg. delay (s)	Movement	Delay (s)
Longfields Dr/Via Modugno PI (U)	C(C)	15.4(22.0)	EB(EB)	0.7(1.3)
Longfields Dr/Via Campanale Ave (U)	C(C)	18.8(18.8)	EB(EB)	0.5(0.5)

Note: Analysis of signalized intersections assumes a PHF of 1.0 and a saturation flow rate of 1800 veh/h/lane.  
(U) - Unsignalized intersection.

As shown in **Table 7** above, intersections in total future background 2025 conditions are projected to operate with higher delays than anticipated for the total future background 2020 conditions.

## 4.5. TRANSPORTATION DEMAND MANAGEMENT

Exempt – see **Section 2.3**.

## 4.6. NEIGHBOURHOOD TRAFFIC MANAGEMENT

---

Exempt – see Section 2.3.

## 4.7. TRANSIT

---

Exempt – see Section 2.3.

## 4.8. REVIEW OF NETWORK CONCEPT

---

Exempt – see Section 2.3.

## 4.9. INTERSECTION DESIGN

---

Exempt – see Section 2.3.

## 5. FINDINGS, CONCLUSIONS AND RECOMMENDATIONS

Based on the results summarized herein the following transportation related conclusions are offered:

- The proposed single-phase development will consist of 28 low-rise apartments and approximately 15,000 ft<sup>2</sup> of commercial space. The anticipated buildout year of the development is 2020.
- The development is planned to provide a total of 55 vehicle parking spaces and 25 bicycle parking spaces, exceeding what is required by the City of Ottawa's parking provisions.
- Three new accesses are proposed to serve the development. Two full-movement accesses will be located along Via Campanale Ave, and one in-bound-only access will be located along Via Modugno Pl.
- The projected number of vehicle trips anticipated to be generated by the development is negligible.
- All MMLoS targets are met and there are no anticipated intersection capacity issues.
- SYNCHRO analysis conducted for all conditions (existing and total future background 2020 and 2025) resulted in a LOS 'C' or better during morning and afternoon peak hour periods.

Based on the foregoing, the proposed development can be well accommodated by the adjacent transportation network and is recommended to proceed from a transportation perspective.

Prepared By:



Basel Ansari, EIT.  
Transportation Planner

Reviewed By:



Mark Baker, P.Eng.  
Senior Transportation Engineer

# Appendix A

Screening Form

---

City of Ottawa 2017 TIA Guidelines

Date

31-May-19

**TIA Screening Form**

Project Campanale - Longfields (Block 14)

Project Number

477167 - 01000

Results of Screening	Yes/No
Development Satisfies the Trip Generation Trigger	No
Development Satisfies the Location Trigger	Yes
Development Satisfies the Safety Trigger	No

Module 1.1 - Description of Proposed Development	
Municipal Address	2 Via Modugno Place
Description of location	Longfields Barrhaven
Land Use	Mixed use
Development Size	28 residential units and 15,000 square foot commercial space
Number of Accesses and Locations	2 proposed accesses (Via Modugno Pl, Via Campanale Ave)
Development Phasing	1 Phase
Buildout Year	2020
Sketch Plan / Site Plan	See attached

Module 1.2 - Trip Generation Trigger		
Land Use Type	Townhomes or Apartments / Commercial Use	
Development Size	28	15,000 sq ft commercial
Trip Generation Trigger Met?	No	

Module 1.3 - Location Triggers	
Development Proposes a new driveway to a boundary street that is designated as part of the City's Transit Priority, Rapid Transit, or Spine Bicycle Networks (See Sheet 3)	No
Development is in a Design Priority Area (DPA) or Transit-oriented Development (TOD) zone.	Yes
Location Trigger Met?	Yes

Module 1.4 - Safety Triggers		
Posted Speed Limit on any boundary road	<80	km/h
Horizontal / Vertical Curvature on a boundary street limits sight lines at a proposed driveway	No	
A proposed driveway is within the area of influence of an adjacent traffic signal or roundabout (i.e. within 300 m of intersection in rural conditions, or within 150 m of intersection in urban/ suburban conditions) or within auxiliary lanes of an intersection;	No	
A proposed driveway makes use of an existing median break that serves an existing site	No	
There is a documented history of traffic operations or safety concerns on the boundary streets within 500 m of the development	No	
The development includes a drive-thru facility	No	
Safety Trigger Met?	No	

**Subject:** RE: 2 Via Modugno PI Strategy Report

**See comment responses in red below.**

**Transportation Engineering Services**

1.
  - a. Ensure that sidewalks along the entire frontage meet City standards, are continuous across accesses And;
  - b. Ensure that there are no sight line issues for vehicles using the proposed access.
    - a. **Noted.**
    - b. **Please see attached sightlines within the report and Figures 1-3 below. As shown in Figure 1, the north access provides sufficient stopping sight distances (SSD) for both east and westbound directions. As displayed in Figure 2, the northbound traffic approaching the west access will have sufficient SSD under normal operations. However, vehicles travelling southbound on Via Campanale Ave will have less than 50m SSD described in TAC, Table 2.5.2, with the assumed operating speed of 40km/h. Since vehicles travelling southbound on Via Campanale Ave will be making a 90 degree turn, operating speed are likely to be less than 40km/h, decreasing the minimum SSD. By assuming the operating speed is 30km/h, SSD decreases to 35m (as per TAC Table 2.5.2), which will give a sufficient SSD as shown in Figure 3.**

*Figure 1: North Access Stopping Sight Distances*





Figure 2: West Access Stopping Sight Distances

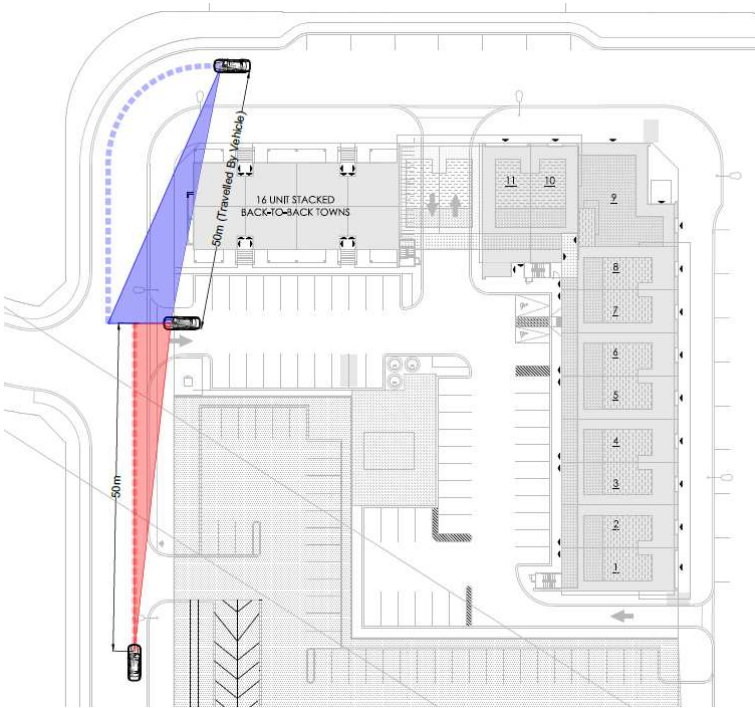
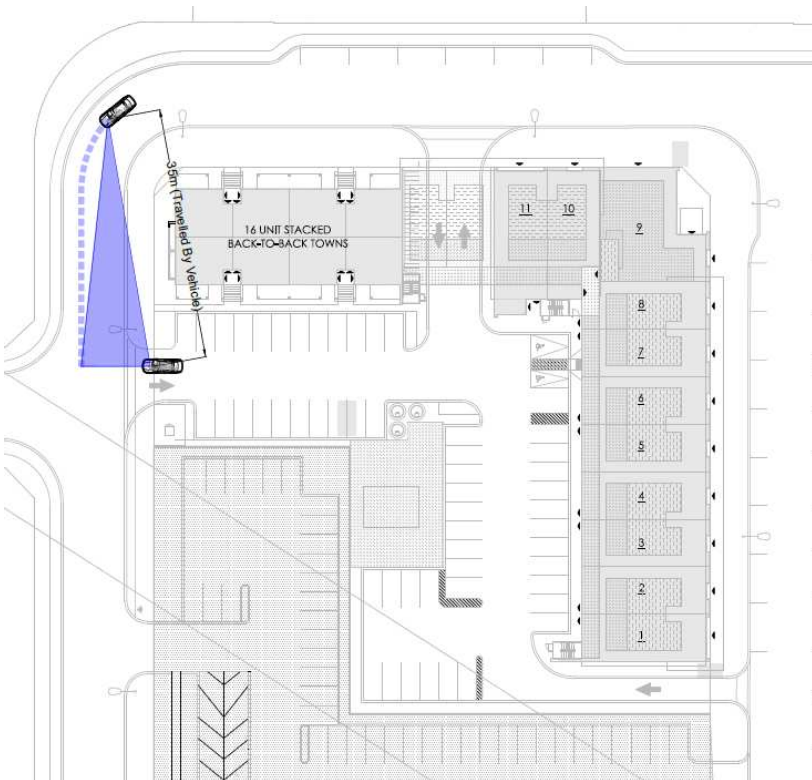

Figure 3: West Access Stopping Site Distance, with Assumed 30km/h Speed



## Traffic Signal Operations

1. Correct the error in Element 4.1.1 second paragraph of the report.  
**Error has been corrected.**

## Traffic Signal Design

No comments.

Noted.

## Street Lighting

1. No comments with initial TIS for this circulation. Street Lighting reserves the right to make future comments based on subsequent submissions.
2. Future considerations are as follows:
  - a. If there are any proposed changes to the existing roadway geometry, the City of Ottawa Street Light Asset Management Group is required to provide a full street light design. Upon completion of proposed roadway geometry design changes, please submit digital Micro Station drawings with proposed roadway geometry changes to the Street Lighting Department, so that we may proceed with the detailed street light design and coordination with the Street Light maintenance provider and all necessary parties.
  - b. Be advised that the applicant will be 100% responsible for all costs associated with any Street Light design as a result of the roadway geometry change.
  - c. Alterations and/or repairs are required where the existing street light plant is directly, indirectly or adversely affected by the scope of work under this circulation, due to the proposed road reconstruction process. All street light plant alterations and/or repairs must be performed by the City of Ottawa's Street Light maintenance provider.
  - d. Be advised that the applicant will be 100% responsible for all costs associated with any relocations/modifications to the existing street light plant.

Noted.

## Transit Services

On behalf of Transit Services there are no further comments.

Noted.

## Development Review – Transportation Engineering Services

1. Remove Draft water mark.  
Draft Water mark removed.
2. Include the Consultant Qualification Letter.  
Qualification letter included.

---

**From:** Baggs, Rosanna <Rosanna.Baggs@ottawa.ca>

**Sent:** Thursday, October 3, 2019 1:58 PM

**To:** Ansari, Basel <Basel.Ansari@parsons.com>

**Cc:** Baker, Mark <Mark.Baker@parsons.com>; Christian Campanale <christian@campanale.com>; Giampa, Mike <Mike.Giampa@ottawa.ca>

**Subject:** [EXTERNAL] RE: 2 Via Modugno PI Strategy Report

Hi Basel,

Please see the comments below:

### **Transportation Engineering Services**

1. Ensure that sidewalks along the entire frontage meet City standards, are continuous across accesses and that there are no sight line issues for vehicles using the proposed access.

### **Traffic Signal Operations**

1. Correct the error in Element 4.1.1 second paragraph of the report.

### **Traffic Signal Design**

No comments.

### **Street Lighting**

1. No comments with initial TIS for this circulation. Street Lighting reserves the right to make future comments based on subsequent submissions.
2. Future considerations are as follows:
  - a. If there are any proposed changes to the existing roadway geometry, the City of Ottawa Street Light Asset Management Group is required to provide a full street light design. Upon completion of proposed roadway geometry design changes, please submit digital Micro Station drawings with proposed roadway geometry changes to the Street Lighting Department, so that we may proceed with the detailed street light design and coordination with the Street Light maintenance provider and all necessary parties.
  - b. Be advised that the applicant will be 100% responsible for all costs associated with any Street Light design as a result of the roadway geometry change.
  - c. Alterations and/or repairs are required where the existing street light plant is directly, indirectly or adversely affected by the scope of work under this circulation, due to the proposed road reconstruction process. All street light plant alterations and/or repairs must be performed by the City of Ottawa's Street Light maintenance provider.
  - d. Be advised that the applicant will be 100% responsible for all costs associated with any relocations/modifications to the existing street light plant.

### **Transit Services**

On behalf of Transit Services there are no further comments.

### **Development Review – Transportation Engineering Services**

1. Remove Draft water mark.
2. Include the Consultant Qualification Letter.

### **Rosanna Baggs, C.E.T.**

Project Manager, Infrastructure Approvals | GPRJ Approbation demandes infrastructure  
Development Review West Branch | Dir Services d'examen des demandes d'aménagement  
Tel | Tél. : 613-580- 2424 ext. | poste 26388

# Appendix B

Truck Turning Templates

---





# Appendix C

OC Transpo Route Maps

---

# 95 ORLÉANS & TRIM BARRHAVEN CAMBRIAN

**7 days a week / 7 jours par semaine**  
All day service  
Service toute la journée

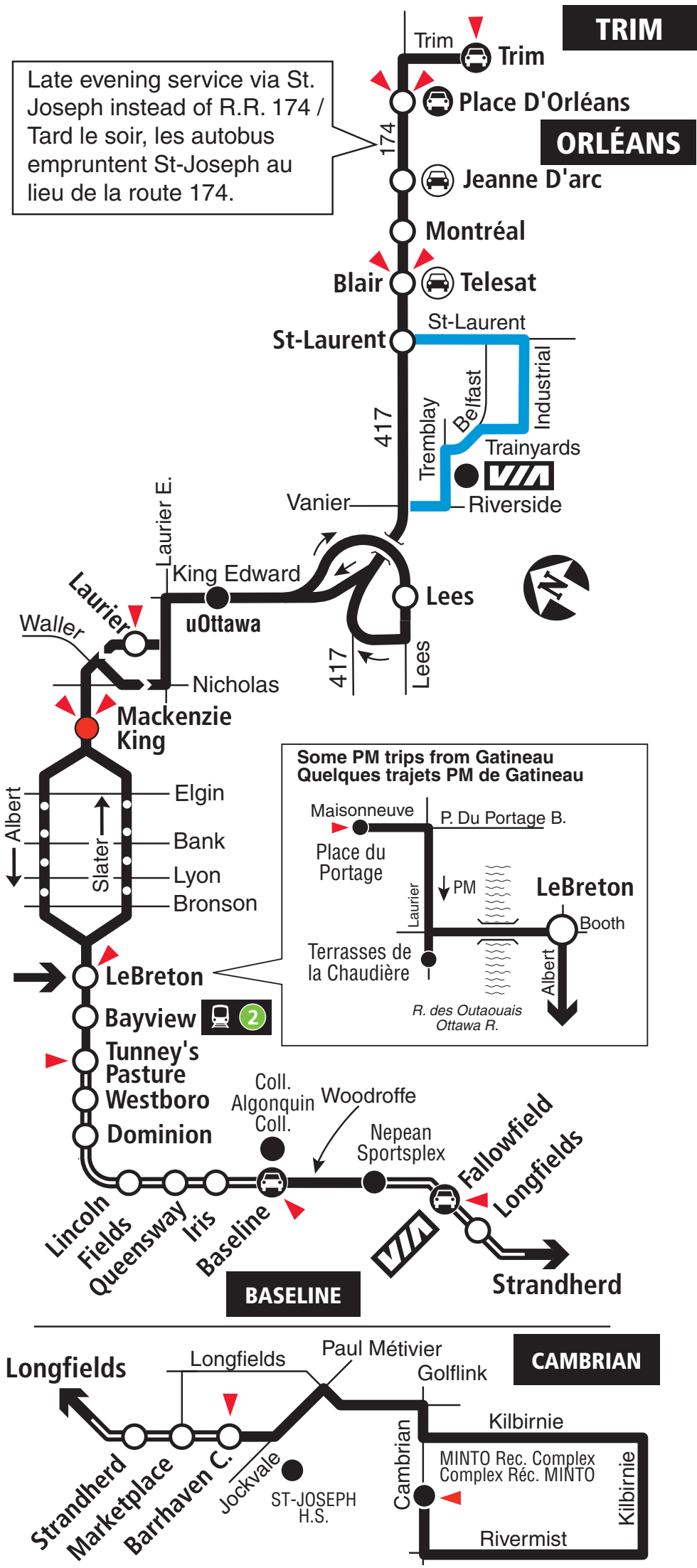

Late evening service via St. Joseph instead of R.R. 174 /  
Tard le soir, les autobus empruntent St-Joseph au lieu de la route 174.

Some PM trips from Gatineau  
Quelques trajets PM de Gatineau

- Transitway & Station
- Timepointe  
Heures de passage
- Late night trips via Rideau St. instead of Mackenzie King /  
Trajets de fin de soirée via la rue Rideau au lieu de la station Mackenzie King
- Early morning service  
Service matinale
- Park & Ride  
Parc-o-bus

2018.10

- Information / Renseignement.....**613-741-4390**
- Customer Relations  
Service à la clientèle .....**613-741-4390**
- Lost and Found / Objets perdus .....**613-563-4011**
- Schedule / Horaire.....**613-560-1000**
- Text / Texto .....**560560**

*plus your four digit bus stop number / plus votre numéro d'arrêt à quatre chiffres*

**Effective / En vigueur Oct. 15 oct. 2018**



# 171

## FALLOWFIELD BARRHAVEN CENTRE

### Local

**7 days a week / 7 jours par semaine**  
All day service  
Service toute la journée

**FALLOWFIELD**

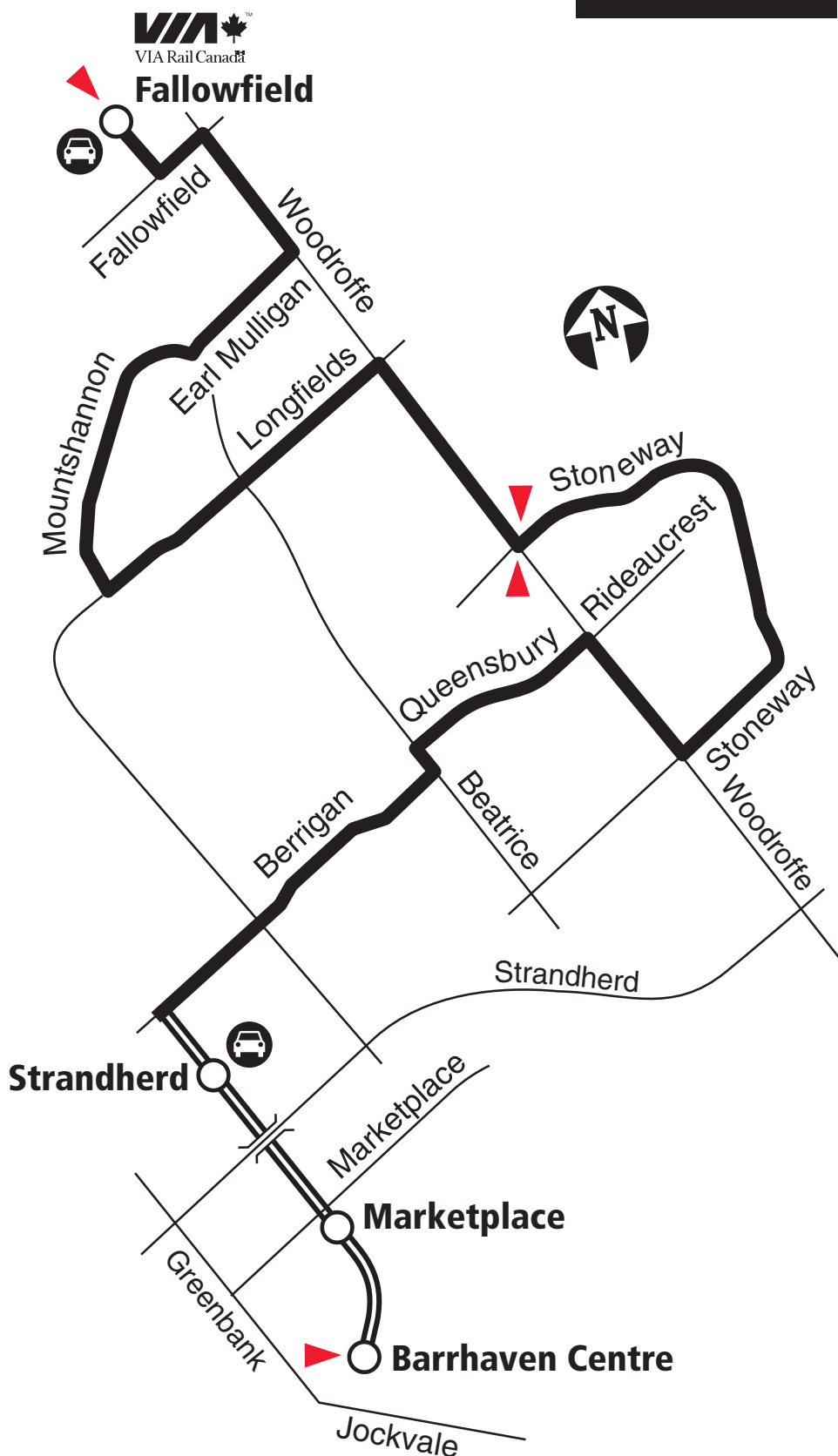

**BARRHAVEN  
CENTRE**



Transitway & Station



Park & Ride / Parc-o-bus



Timepoint / Heures de passage

2017.01



**Schedule / Horaire.....613-560-1000**

**Text / Texto .....560560**

*plus your four digit bus stop number / plus votre numéro d'arrêt à quatre chiffres*

Customer Relations

Service à la clientèle ..... **613-842-3600**

Lost and Found / Objets perdus..... **613-563-4011**

Security / Sécurité ..... **613-741-2478**

**Effective December 23, 2012**

**En vigueur 23 décembre 2012**



INFO 613-741-4390  
octranspo.com

# 271

## MACKENZIE KING BARRHAVEN

**Connexion**

**Monday to Friday / Lundi au vendredi**

Peak periods only  
Périodes de pointe seulement

**AM**  
↑  
**MACKENZIE KING**

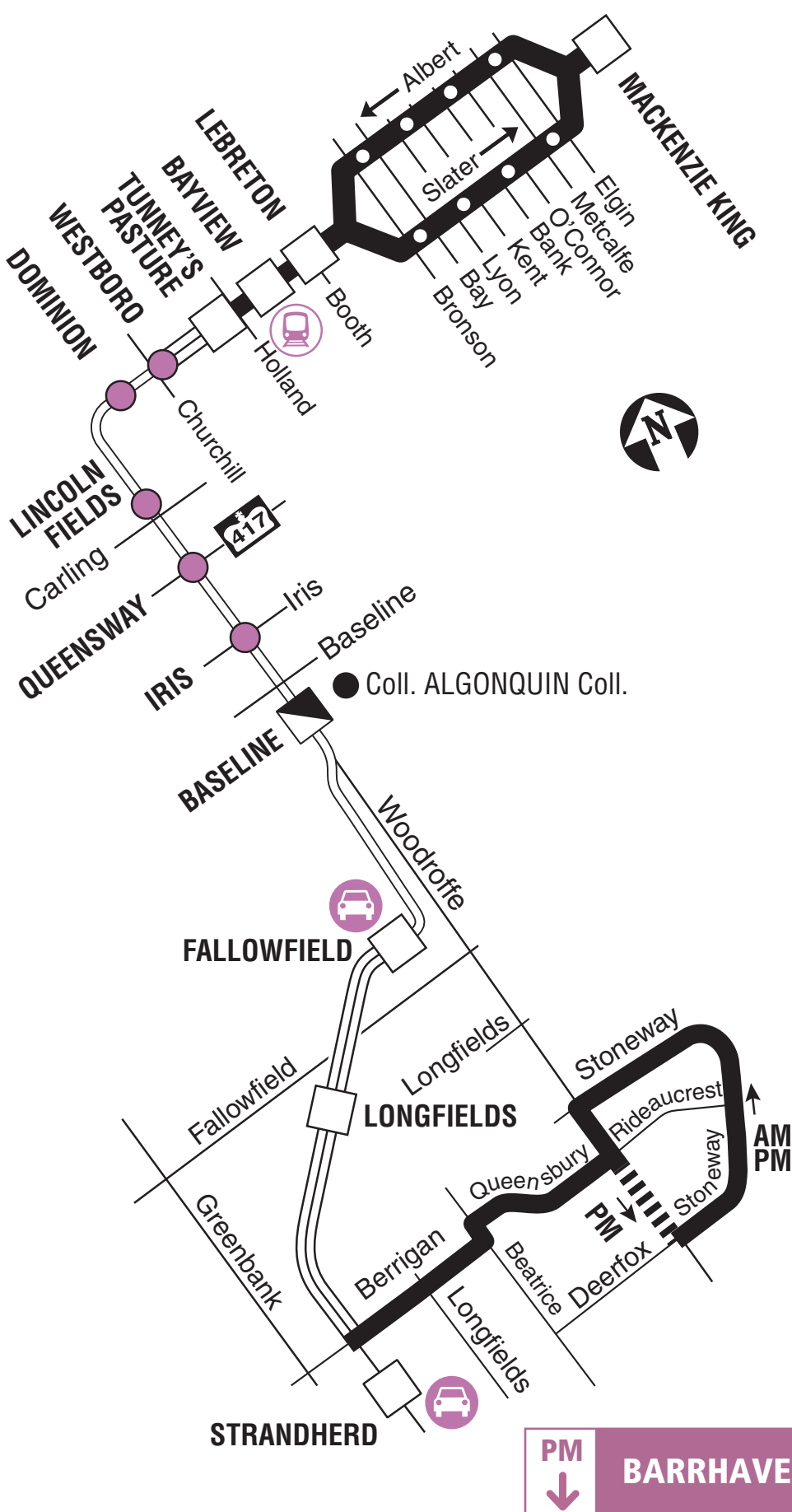

**PM**  
↓  
**BARRHAVEN**

**Legend • Légende**

- Transitway & Station
- Limited stops: Off only in AM / No stop in PM  
*Arrêts limités : Débarquement en AM seulement / Aucun arrêt en PM*
- Off only in AM / Full service in PM  
*Débarquement en AM seulement / Service complet en PM*
- Line 2 – O-Train Trillium Line  
*Ligne 2 - O-Train Ligne Trillium*
- Park & Ride / *Parc-o-bus*

2016.12

Information / Renseignement ..... **613-741-4390**  
 Customer Relations  
 Service à la clientèle ..... **613-842-3600**  
 Lost and Found / Objets perdus ..... **613-563-4011**  
 Transecure ..... **613-741-2478**

Schedule / Horaire ..... **613-560-1000**  
 Text / Texto ..... **560560**  
*plus your four digit bus stop number / plus votre numéro d'arrêt à quatre chiffres*

**Effective December 25, 2016**  
**En vigueur 25 décembre 2016**



# 273

## MACKENZIE KING TARTAN

### Connexion

Monday to Friday / Lundi au vendredi

Peak periods only

Périodes de pointe seulement

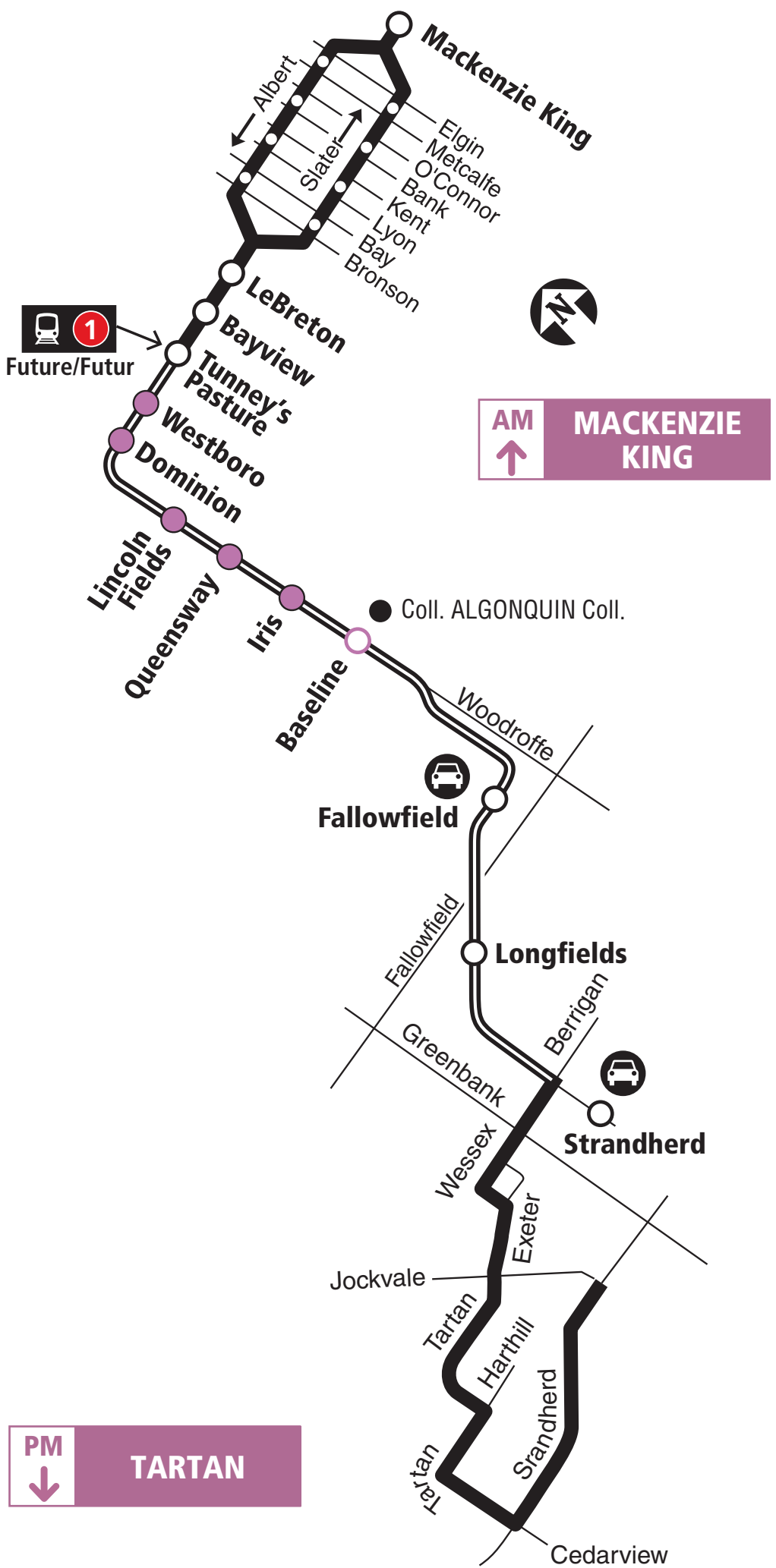

2018.05



**Schedule / Horaire.....613-560-1000**

**Text / Texto .....560560**

*plus your four digit bus stop number / plus votre numéro d'arrêt à quatre chiffres*

Customer Relations  
Service à la clientèle ..... **613-842-3600**

Lost and Found / Objets perdus..... **613-563-4011**

Security / Sécurité ..... **613-741-2478**

**Effective December 25, 2016**

**En vigueur 25 décembre 2016**



INFO 613-741-4390  
octranspo.com





# 275

## CAMBRIAN

## MACKENZIE KING

### Connexion

#### Monday to Friday / Lundi au vendredi

Peak periods only

Périodes de pointe seulement

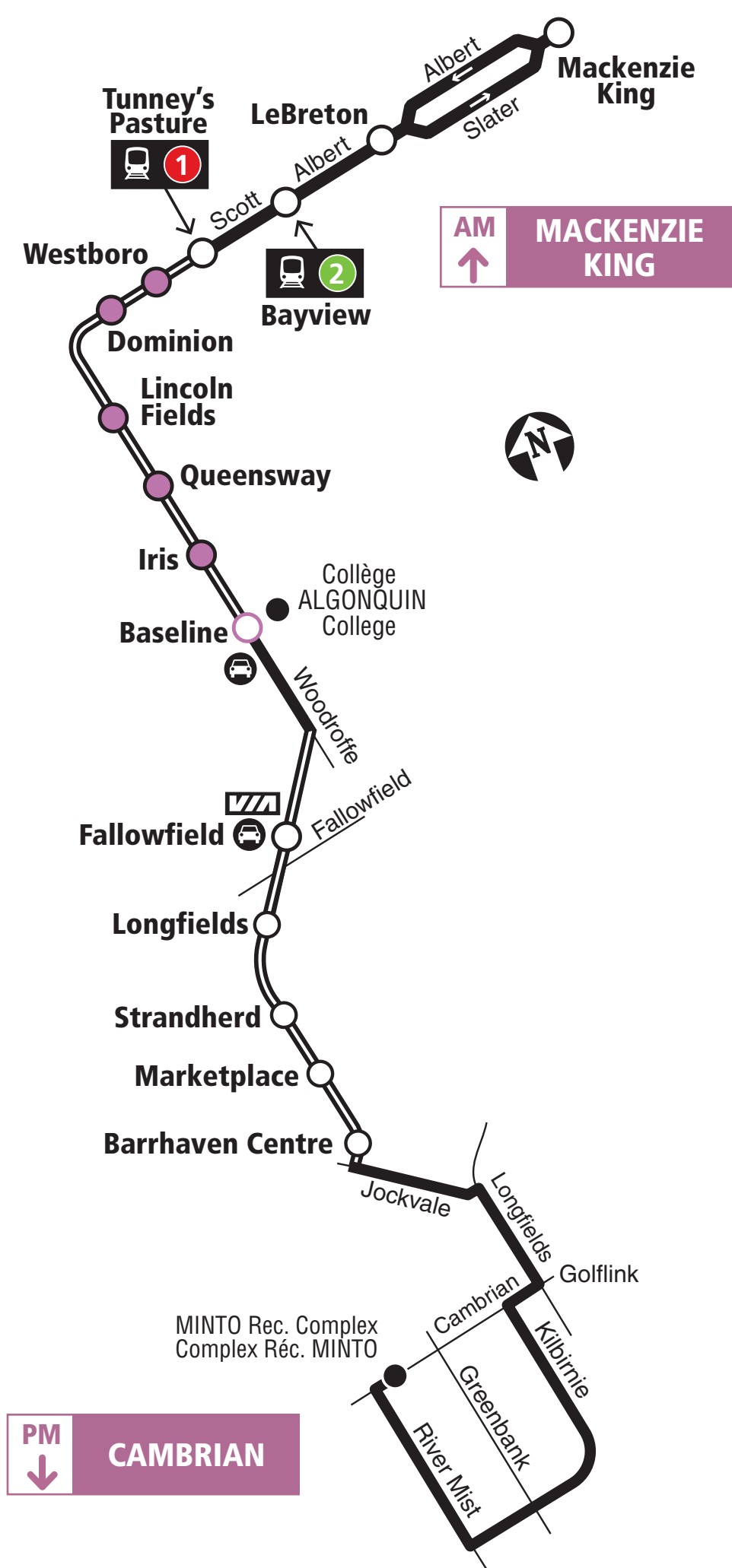

Transitway & Station



Limited stops: Off only in AM / No stop in PM  
Arrêts limités : Débarquement en AM seulement / Aucun arrêt en PM



Limited stops: Off only in AM / Full service in PM  
Arrêts limités : Débarquement en AM seulement / Service complet en PM



Park & Ride / Parc-o-bus

2018.12



**Schedule / Horaire.....613-560-1000**

**Text / Texto .....560560**

*plus your four digit bus stop number / plus votre numéro d'arrêt à quatre chiffres*

Customer Relations

Service à la clientèle ..... **613-741-4390**

Lost and Found / Objets perdus..... **613-563-4011**

Security / Sécurité ..... **613-741-2478**

**Effective December 23, 2018**

**En vigueur 23 décembre 2018**



INFO 613-741-4390  
octranspo.com

# Appendix D

Traffic Counts

---



# Turning Movement Count Bicycle Summary Flow Diagram



## Longfields Drive & Via Campanale Avenue Nepean, ON

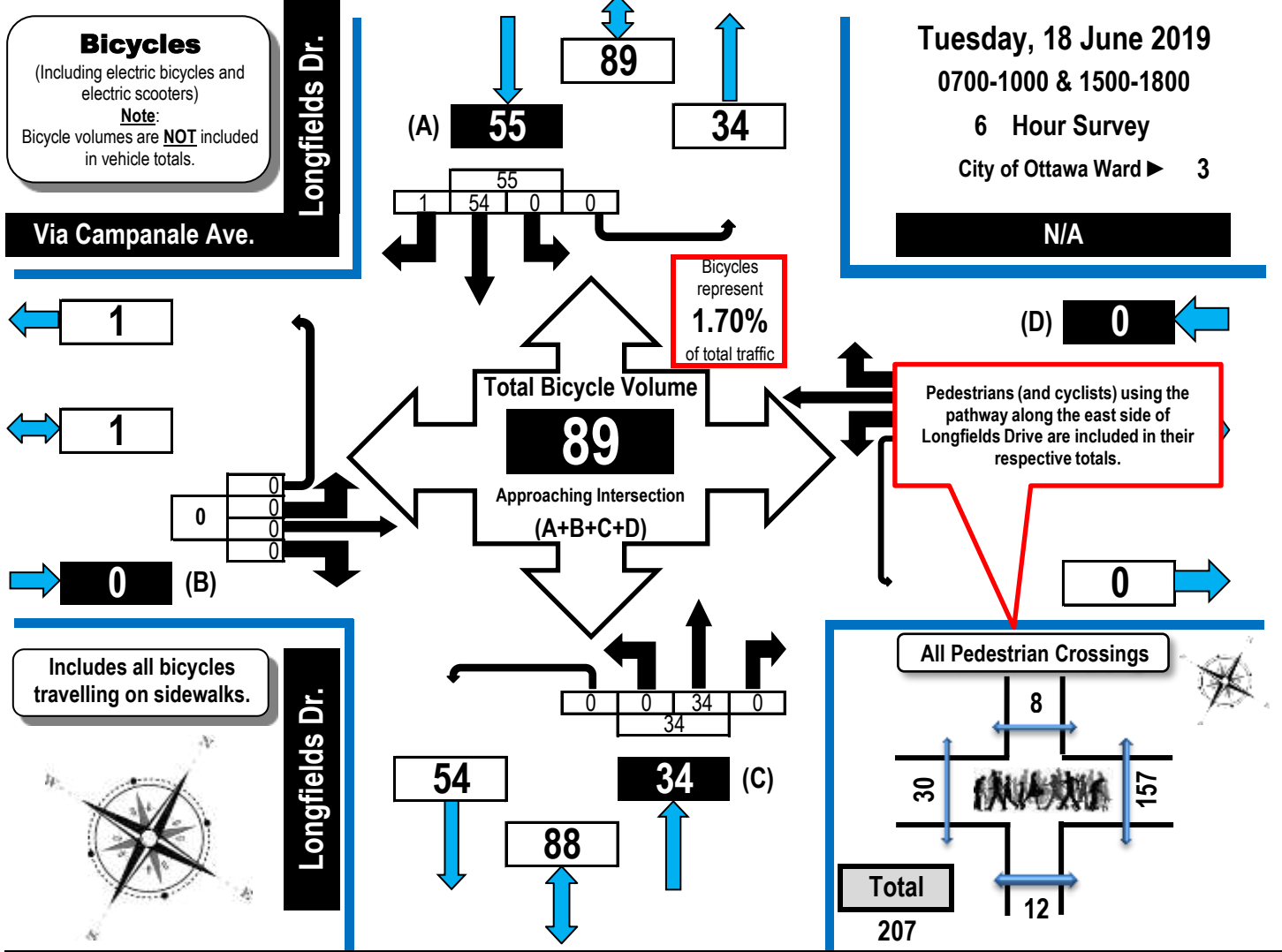

Time Period	Via Campanale Ave. Eastbound					N/A Westbound					Longfields Dr. Northbound					Longfields Dr. Southbound					G.Tot.
	LT	ST	RT	UT	S. Tot.	LT	ST	RT	UT	S. Tot.	LT	ST	RT	UT	S. Tot.	LT	ST	RT	UT	S. Tot.	
0700-0800	0	0	0	0	0	0	0	0	0	0	0	3	0	0	3	0	2	0	0	2	5
0800-0900	0	0	0	0	0	0	0	0	0	0	0	14	0	0	14	0	22	0	0	22	36
0900-1000	0	0	0	0	0	0	0	0	0	0	0	6	0	0	6	0	3	0	0	3	9
1500-1600	0	0	0	0	0	0	0	0	0	0	0	7	0	0	7	0	11	0	0	11	18
1600-1700	0	0	0	0	0	0	0	0	0	0	0	1	0	0	1	0	7	0	0	7	8
1700-1800	0	0	0	0	0	0	0	0	0	0	0	3	0	0	3	0	9	1	0	10	13
<b>Totals</b>	<b>0</b>	<b>0</b>	<b>0</b>	<b>0</b>	<b>0</b>	<b>0</b>	<b>0</b>	<b>0</b>	<b>0</b>	<b>0</b>	<b>0</b>	<b>34</b>	<b>0</b>	<b>0</b>	<b>34</b>	<b>0</b>	<b>54</b>	<b>1</b>	<b>0</b>	<b>55</b>	<b>89</b>

**Comments:**  
New housing construction underway west of Longfields Drive. Although this is a 'T' intersection, pedestrians and cyclists were counted on all quadrants.



# Turning Movement Count Summary, AM and PM Peak Hour Flow Diagrams

Automobiles, Taxis, Light Trucks, Vans, SUV's, Motorcycles, Heavy Trucks, Buses, and School Buses

## Longfields Drive & Via Campanale Avenue Nepean, ON

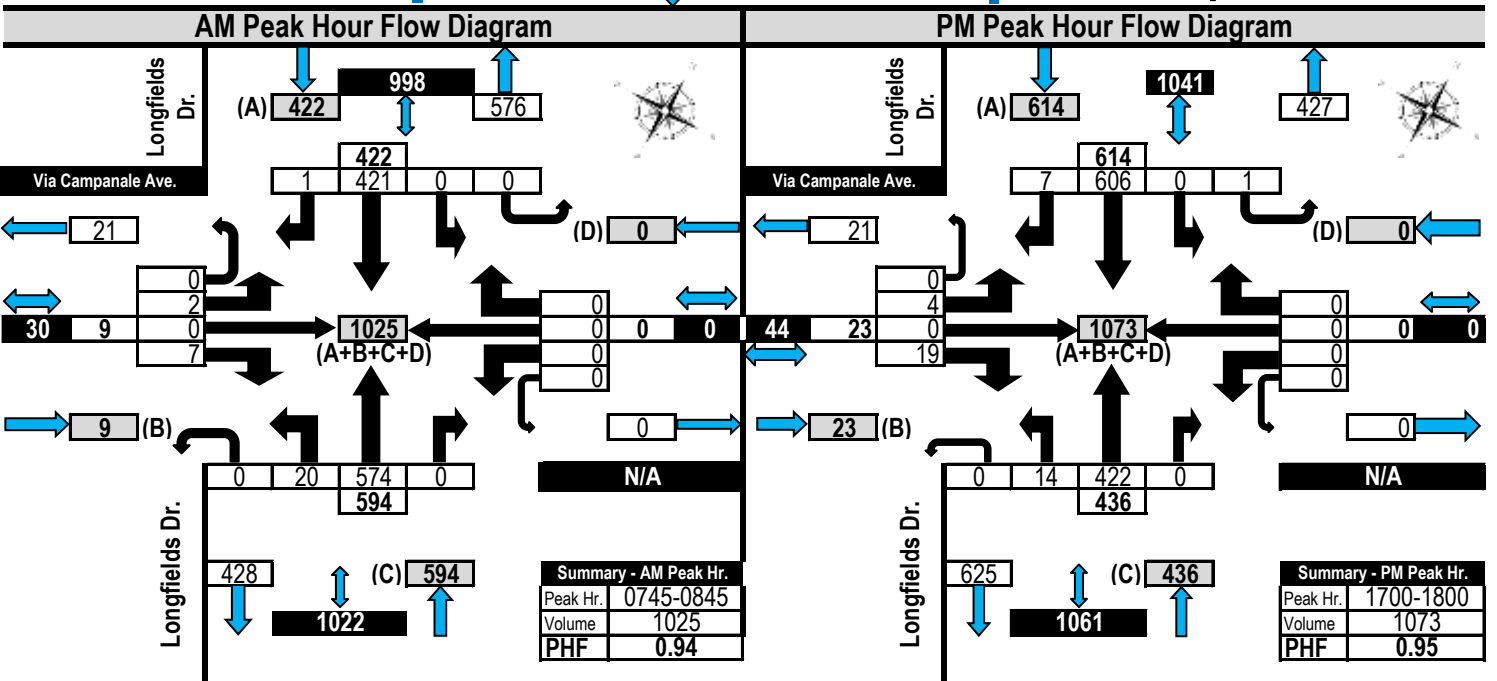
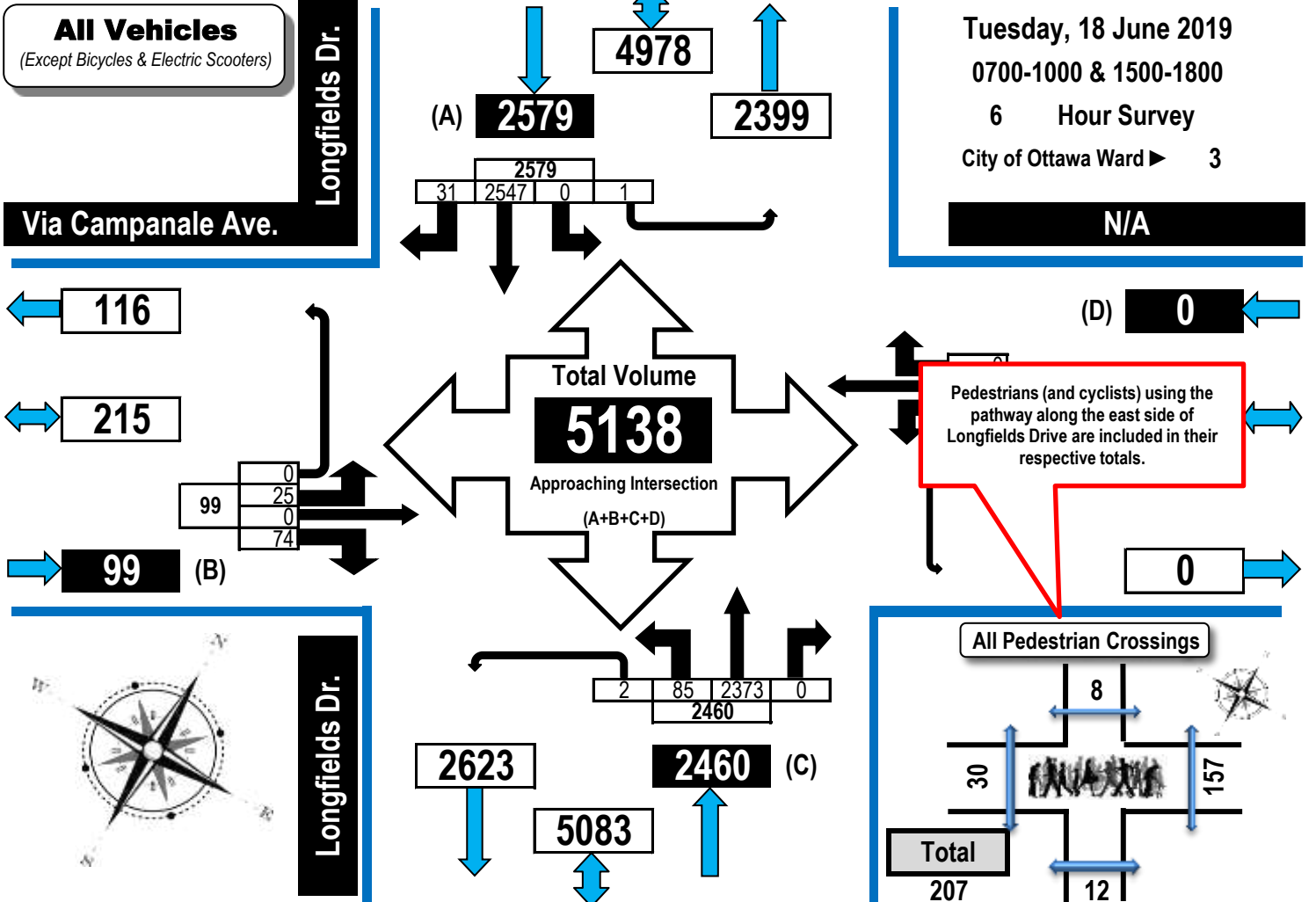



# Turning Movement Count Heavy Vehicle Summary Flow Diagram

Heavy Trucks, Buses,  
and School Buses

## Longfields Drive & Via Campanale Avenue Nepean, ON

**Tuesday, 18 June 2019**  
0700-1000 & 1500-1800  
6 Hour Survey  
City of Ottawa Ward ▶ 3

**Heavy Vehicles**  
(Construction Vehicles, Heavy Trucks, Buses & School Buses).  
Heavy vehicle totals ARE included in the all vehicles summary and flow diagrams.

**Via Campanale Ave.**

**Longfields Dr.**

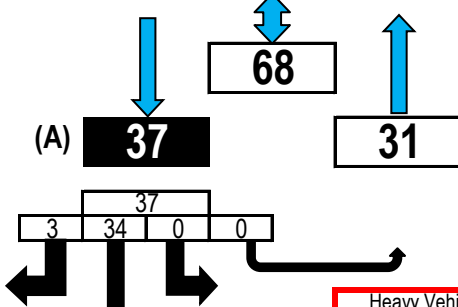
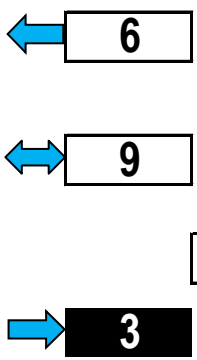

**N/A**

Heavy Vehicles Represent  
**1.42%**  
of Total Traffic

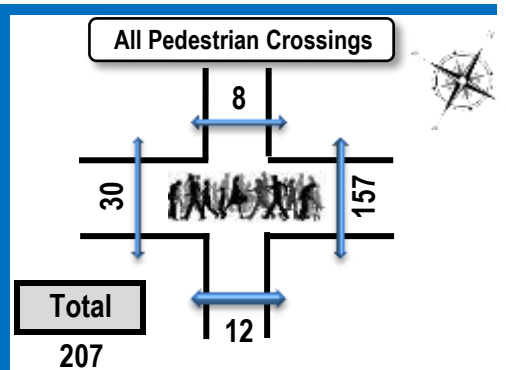
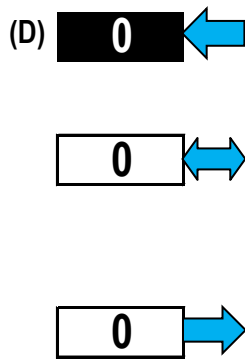
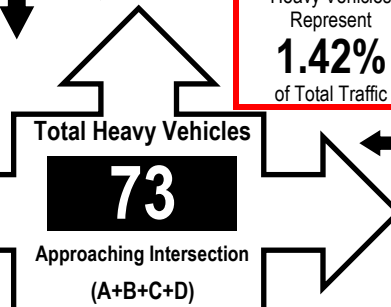

Via Campanale Ave.	N/A	Longfields Dr.	Longfields Dr.
Eastbound	Westbound	Northbound	Southbound

Time Period	Via Campanale Ave. Eastbound					N/A Westbound					Longfields Dr. Northbound					Longfields Dr. Southbound					G.Tot.
	LT	ST	RT	UT	S. Tot.	LT	ST	RT	UT	S. Tot.	LT	ST	RT	UT	S. Tot.	LT	ST	RT	UT	S. Tot.	
0700-0800	0	0	0	0	0	0	0	0	0	0	0	8	0	0	8	0	3	0	0	3	11
0800-0900	0	0	0	0	0	0	0	0	0	0	2	10	0	0	12	0	7	1	0	8	20
0900-1000	0	0	0	0	0	0	0	0	0	0	0	1	0	0	1	0	9	0	0	9	10
1500-1600	1	0	0	0	1	0	0	0	0	0	1	7	0	0	8	0	10	1	0	11	20
1600-1700	0	0	2	0	2	0	0	0	0	0	0	2	0	0	2	0	2	1	0	3	7
1700-1800	0	0	0	0	0	0	0	0	0	0	0	2	0	0	2	0	3	0	0	3	5
<b>Totals</b>	<b>1</b>	<b>0</b>	<b>2</b>	<b>0</b>	<b>3</b>	<b>0</b>	<b>0</b>	<b>0</b>	<b>0</b>	<b>0</b>	<b>3</b>	<b>30</b>	<b>0</b>	<b>0</b>	<b>33</b>	<b>0</b>	<b>34</b>	<b>3</b>	<b>0</b>	<b>37</b>	<b>73</b>

**Comments:**

New housing construction underway west of Longfields Drive. Although this is a 'T' intersection, pedestrians and cyclists were counted on all quadrants.





# Turning Movement Count Pedestrian Crossings Summary and Flow Diagram



## Longfields Drive & Via Campanale Avenue Nepean, ON

**Pedestrian Crossings**

**Tuesday, 18 June 2019**  
**0700-1000 & 1500-1800**  
**6 Hour Survey**  
**City of Ottawa Ward 3**

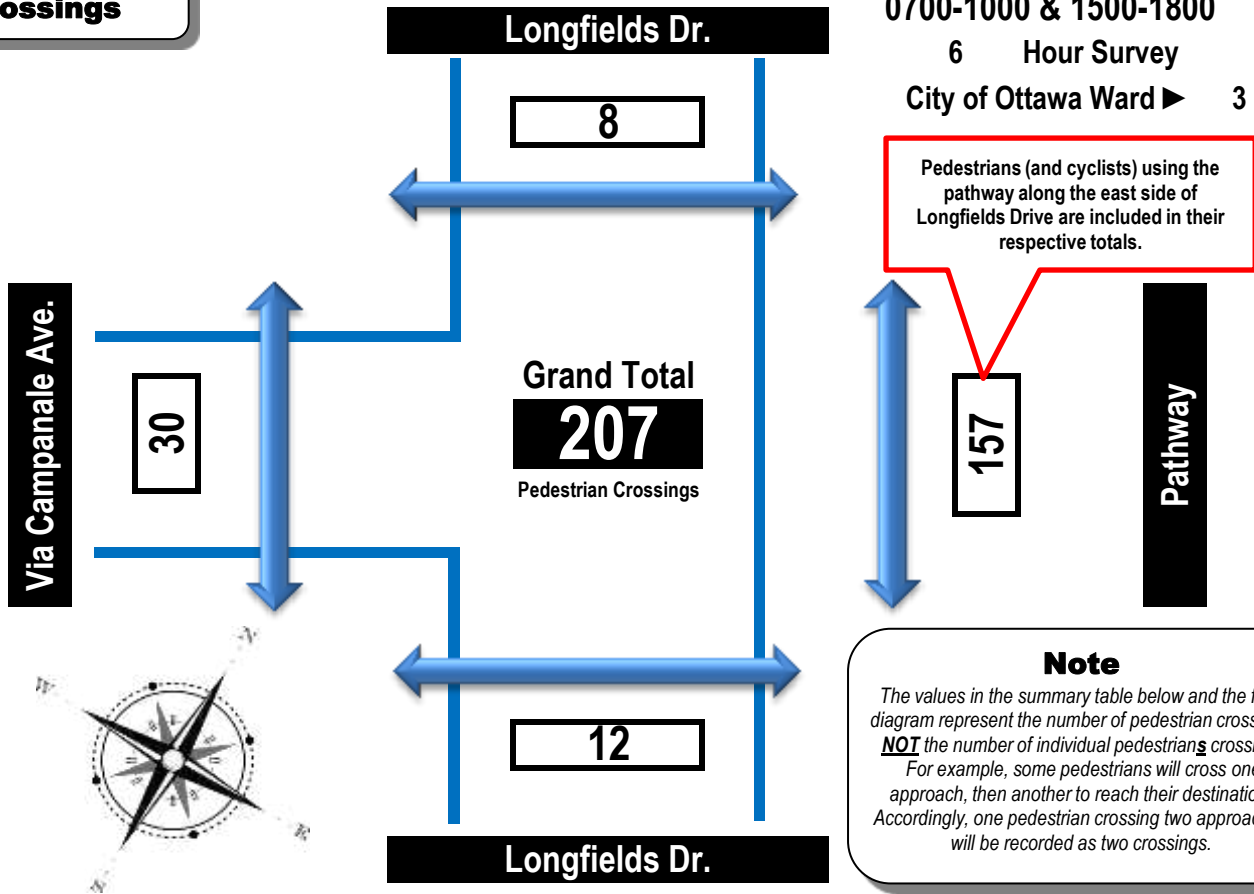

Time Period	West Side Crossing Via Campanale Ave.	East Side on Ped/Bike Path	Street Total	South Side Crossing Longfields Dr.	North Side Crossing Longfields Dr.	Street Total	Grand Total
0700-0800	0	9	9	0	0	0	9
0800-0900	5	34	39	2	4	6	45
0900-1000	5	29	34	1	2	3	37
1500-1600	3	37	40	3	1	4	44
1600-1700	12	14	26	6	1	7	33
1700-1800	5	34	39	0	0	0	39
<b>Totals</b>	<b>30</b>	<b>157</b>	<b>187</b>	<b>12</b>	<b>8</b>	<b>20</b>	<b>207</b>

**Comments:**

New housing construction underway west of Longfields Drive. Although this is a 'T' intersection, pedestrians and cyclists were counted on all quadrants.



# Turning Movement Count Summary Report AADT and Expansion Factors

Automobiles, Taxis,  
Light Trucks, Vans,  
SUV's, Motorcycles,  
Heavy Trucks, Buses,  
and School Buses

## Longfields Drive & Via Campanale Avenue Nepean, ON

**Survey Date:** Tuesday, 18 June 2019      **Start Time:** 0700      **AADT Factor:** 0.9  
**Weather AM:** Clear +12°C      **Survey Duration:** 6 Hrs.      **Survey Hours:** 0700-1000 & 1500-1800  
**Weather PM:** Partly Cloudy +26°C      **Surveyor(s):** Carmody

### Via Campanale Ave.

N/A

### Longfields Dr.

### Longfields Dr.

Time Period	Eastbound					Westbound					W/B Tot	Street Total	Northbound				Southbound				S/B Tot	Street Total	Grand Total
	LT	ST	RT	UT	E/B Tot	LT	ST	RT	UT	LT			ST	RT	UT	N/B Tot	LT	ST	RT	UT			
0700-0800	2	0	5	0	7	0	0	0	0	0	7	10	476	0	0	486	0	264	4	0	268	754	761
0800-0900	5	0	8	0	13	0	0	0	0	0	13	20	555	0	0	575	0	396	2	0	398	973	986
0900-1000	3	0	9	0	12	0	0	0	0	0	12	11	247	0	0	258	0	268	6	0	274	532	544
1500-1600	4	0	17	0	21	0	0	0	0	0	21	12	319	0	2	333	0	505	6	0	511	844	865
1600-1700	7	0	16	0	23	0	0	0	0	0	23	18	354	0	0	372	0	508	6	0	514	886	909
1700-1800	4	0	19	0	23	0	0	0	0	0	23	14	422	0	0	436	0	606	7	1	614	1050	1073
<b>Totals</b>	<b>25</b>	<b>0</b>	<b>74</b>	<b>0</b>	<b>99</b>	<b>0</b>	<b>0</b>	<b>0</b>	<b>0</b>	<b>0</b>	<b>99</b>	<b>85</b>	<b>2373</b>	<b>0</b>	<b>2</b>	<b>2460</b>	<b>0</b>	<b>2547</b>	<b>31</b>	<b>1</b>	<b>2579</b>	<b>5039</b>	<b>5138</b>

### Equivalent 12 & 24-hour Vehicle Volumes Including the Annual Average Daily Traffic (AADT) Factor Applicable to the Day and Month of the Turning Movement Count

**Expansion factors are applied exclusively to standard weekday 8-hour turning movement counts conducted during the hours of 0700h - 1000h, 1130h - 1330h and 1500h - 1800h**

Equivalent 12-hour vehicle volumes. These volumes are calculated by multiplying the 8-hour totals by the 8 → 12 expansion factor of 1.39																						
Equ. 12 Hr	n/a	n/a	n/a	n/a	n/a	n/a	n/a	n/a	n/a	n/a	n/a	n/a	n/a	n/a	n/a	n/a	n/a	n/a	n/a	n/a	n/a	n/a
Average daily 12-hour vehicle volumes. These volumes are calculated by multiplying the equivalent 12-hour totals by the AADT factor of: 0.9																						
AADT 12-hr	n/a	n/a	n/a	n/a	n/a	n/a	n/a	n/a	n/a	n/a	n/a	n/a	n/a	n/a	n/a	n/a	n/a	n/a	n/a	n/a	n/a	n/a
24-Hour AADT. These volumes are calculated by multiplying the average daily 12-hour vehicle volumes by the 12 → 24 expansion factor of 1.31																						
AADT 24 Hr	n/a	n/a	n/a	n/a	n/a	n/a	n/a	n/a	n/a	n/a	n/a	n/a	n/a	n/a	n/a	n/a	n/a	n/a	n/a	n/a	n/a	n/a

### AADT and expansion factors provided by the City of Ottawa

AM Peak Hour Factor → 0.94											Highest Hourly Vehicle Volume Between 0700h & 1000h												
AM Peak Hr	LT	ST	RT	UT	TOT	LT	ST	RT	UT	TOT	S.TOT	LT	ST	RT	UT	TOT	LT	ST	RT	UT	TOT	S.TOT	G.TOT
0745-0845	2	0	7	0	9	0	0	0	0	0	9	20	574	0	0	594	0	421	1	0	422	1016	1025

PM Peak Hour Factor → 0.95											Highest Hourly Vehicle Volume Between 1500h & 1800h												
PM Peak Hr	LT	ST	RT	UT	TOT	LT	ST	RT	UT	TOT	S.TOT	LT	ST	RT	UT	TOT	LT	ST	RT	UT	TOT	S.TOT	G.TOT
1700-1800	4	0	19	0	23	0	0	0	0	0	23	14	422	0	0	436	0	606	7	1	614	1050	1073

### Comments:

New housing construction underway west of Longfields Drive. Although this is a 'T' intersection, pedestrians and cyclists were counted on all quadrants.

### Notes:

1. Includes all vehicle types except bicycles, electric bicycles, and electric scooters.
2. When expansion and AADT factors are applied, the results will differ slightly due to rounding.



# Turning Movement Count Bicycle Summary Flow Diagram



## Longfields Drive & Via Modugno Avenue Nepean, ON

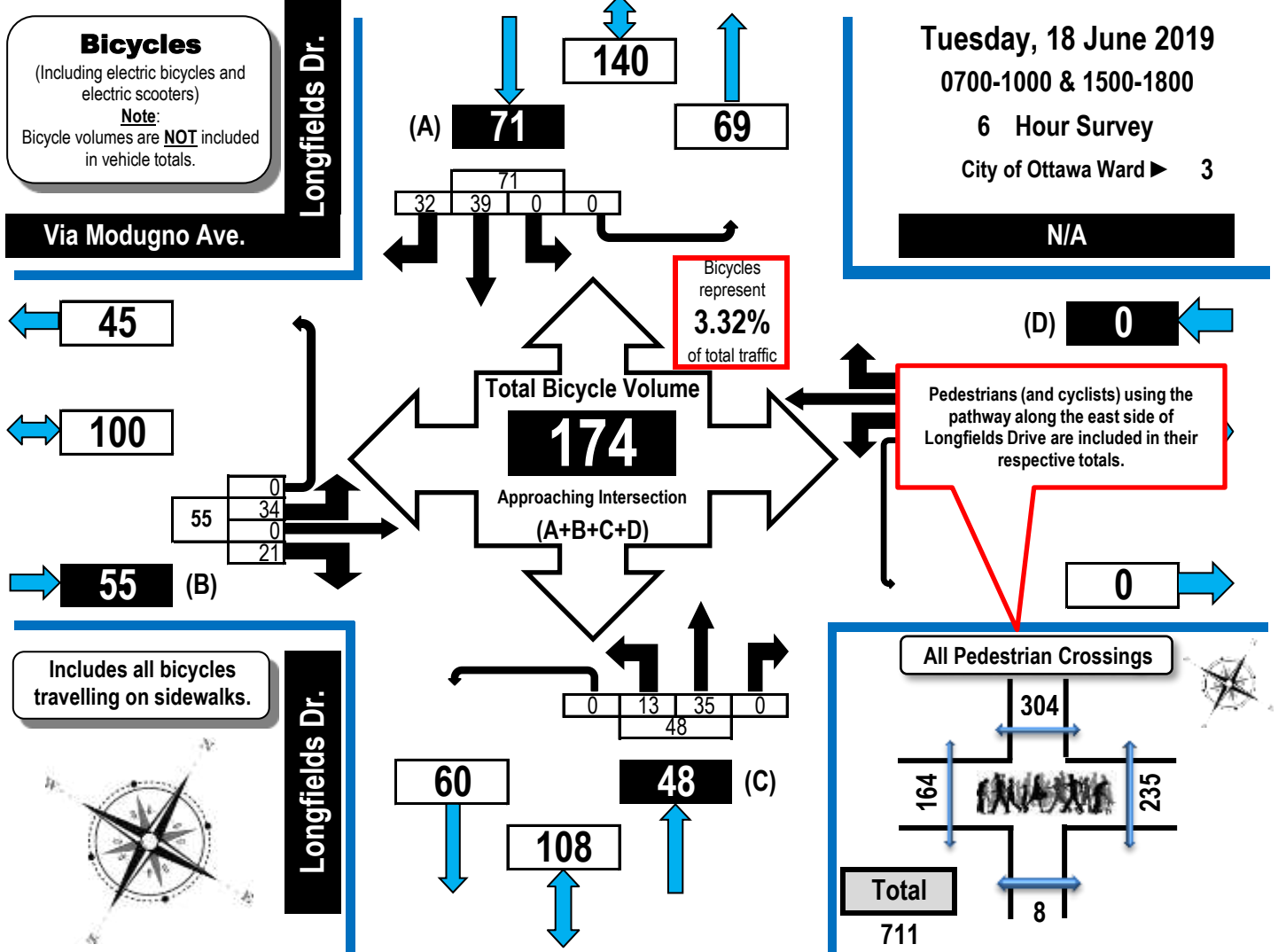

Time Period	Via Modugno Ave. Eastbound					N/A Westbound					Longfields Dr. Northbound					Longfields Dr. Southbound					G.Tot.
	LT	ST	RT	UT	S. Tot.	LT	ST	RT	UT	S. Tot.	LT	ST	RT	UT	S. Tot.	LT	ST	RT	UT	S. Tot.	
0700-0800	2	0	1	0	3	0	0	0	0	0	2	2	0	0	4	0	1	0	0	1	8
0800-0900	21	0	9	0	30	0	0	0	0	0	3	11	0	0	14	0	17	0	0	17	61
0900-1000	5	0	1	0	6	0	0	0	0	0	3	5	0	0	8	0	2	3	0	5	19
1500-1600	3	0	3	0	6	0	0	0	0	0	3	11	0	0	14	0	10	24	0	34	54
1600-1700	3	0	5	0	8	0	0	0	0	0	1	3	0	0	4	0	3	3	0	6	18
1700-1800	0	0	2	0	2	0	0	0	0	0	1	3	0	0	4	0	6	2	0	8	14
<b>Totals</b>	<b>34</b>	<b>0</b>	<b>21</b>	<b>0</b>	<b>55</b>	<b>0</b>	<b>0</b>	<b>0</b>	<b>0</b>	<b>0</b>	<b>13</b>	<b>35</b>	<b>0</b>	<b>0</b>	<b>48</b>	<b>0</b>	<b>39</b>	<b>32</b>	<b>0</b>	<b>71</b>	<b>174</b>

**Comments:**  
New housing construction underway west of Longfields Drive. Although this is a 'T' intersection, pedestrians and cyclists were counted on all quadrants. There was a school field trip between 0945 & 1000 resulting in a substantial increase in pedestrian crossings during that time period. Several drivers completely ignored the red pedestrian signal regardless of whether adults or children were waiting to cross Longfields Drive.



# Turning Movement Count Summary, AM and PM Peak Hour Flow Diagrams

Automobiles, Taxis, Light Trucks, Vans, SUV's, Motorcycles, Heavy Trucks, Buses, and School Buses

## Longfields Drive & Via Modugno Avenue Nepean, ON

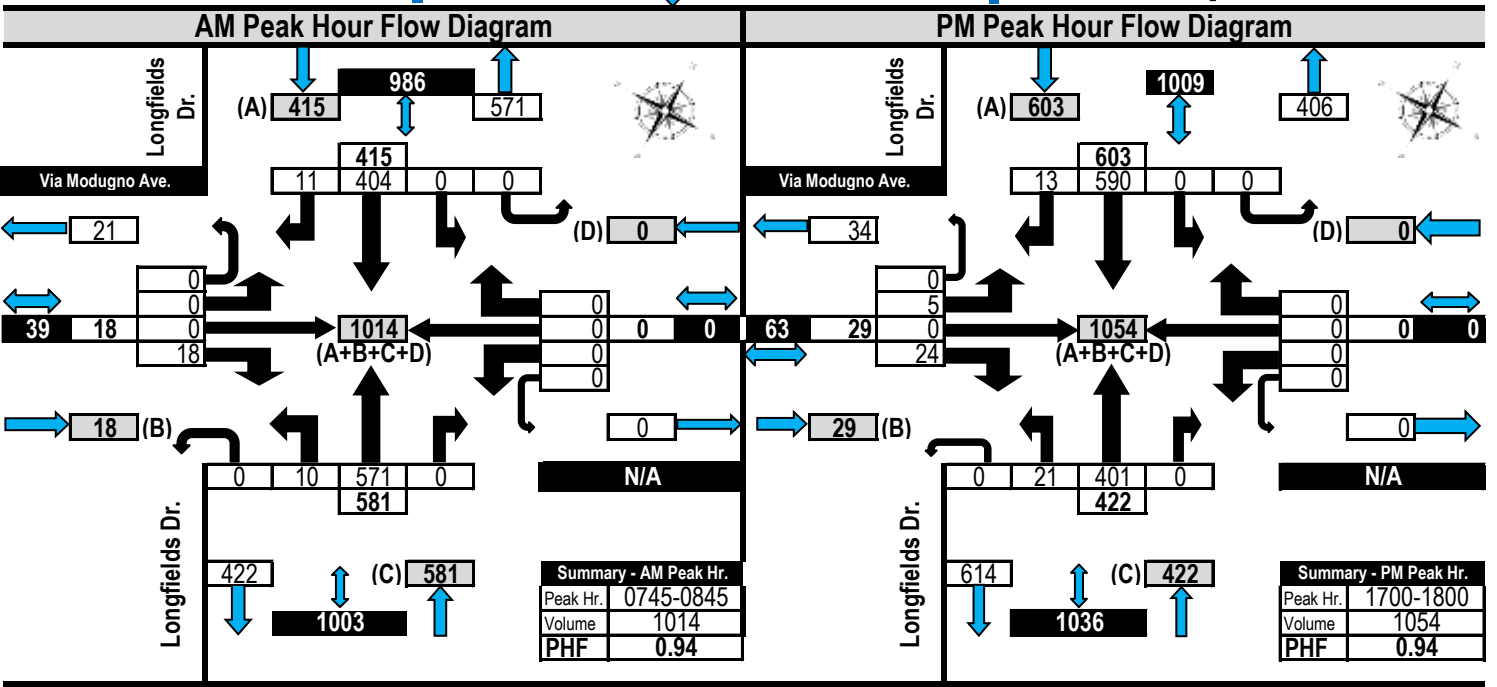
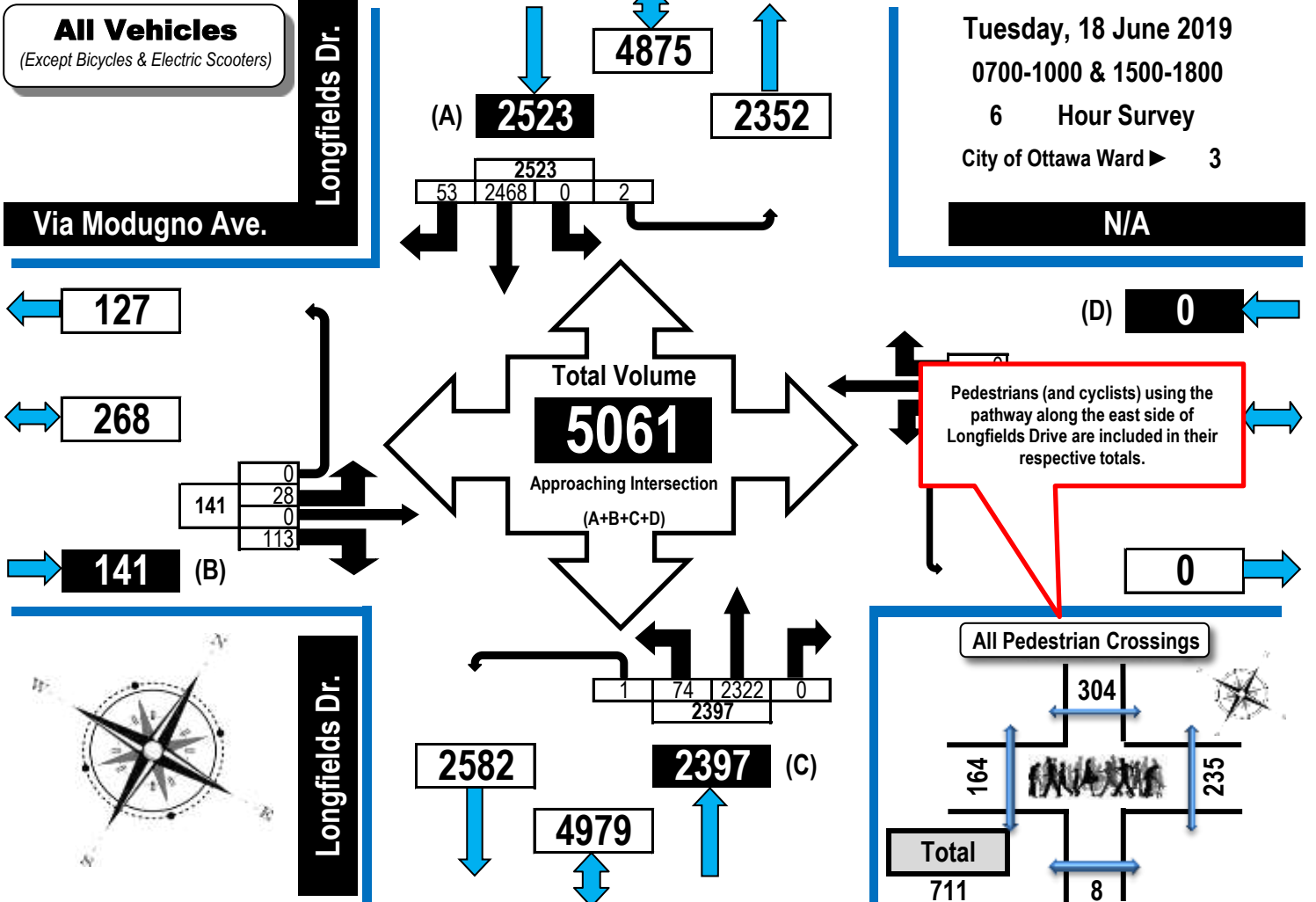



# Turning Movement Count Heavy Vehicle Summary Flow Diagram

Heavy Trucks, Buses,  
and School Buses

## Longfields Drive & Via Modugno Avenue Nepean, ON

**Tuesday, 18 June 2019**  
0700-1000 & 1500-1800  
6 Hour Survey  
City of Ottawa Ward ▶ 3

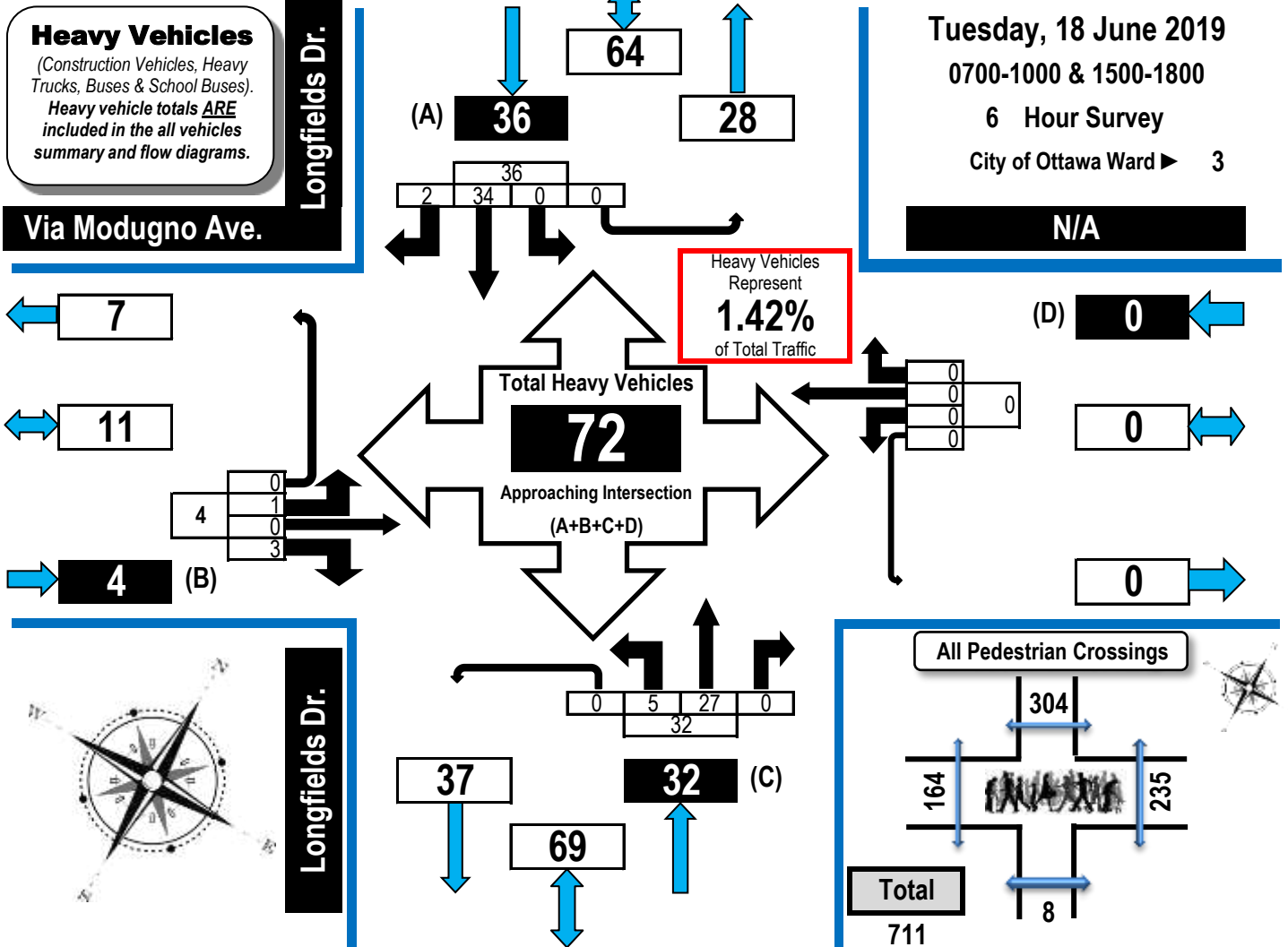

Via Modugno Ave.	N/A	Longfields Dr.	Longfields Dr.
Eastbound	Westbound	Northbound	Southbound

Time Period	Via Modugno Ave. Eastbound					N/A Westbound					Longfields Dr. Northbound					Longfields Dr. Southbound					G.Tot.
	LT	ST	RT	UT	S. Tot.	LT	ST	RT	UT	S. Tot.	LT	ST	RT	UT	S. Tot.	LT	ST	RT	UT	S. Tot.	
0700-0800	0	0	1	0	1	0	0	0	0	0	2	6	0	0	8	0	2	1	0	3	12
0800-0900	0	0	1	0	1	0	0	0	0	0	3	9	0	0	12	0	7	0	0	7	20
0900-1000	0	0	1	0	1	0	0	0	0	0	0	1	0	0	1	0	9	0	0	9	11
1500-1600	0	0	0	0	0	0	0	0	0	0	0	7	0	0	7	0	9	1	0	10	17
1600-1700	1	0	0	0	1	0	0	0	0	0	0	2	0	0	2	0	4	0	0	4	7
1700-1800	0	0	0	0	0	0	0	0	0	0	0	2	0	0	2	0	3	0	0	3	5
<b>Totals</b>	<b>1</b>	<b>0</b>	<b>3</b>	<b>0</b>	<b>4</b>	<b>0</b>	<b>0</b>	<b>0</b>	<b>0</b>	<b>0</b>	<b>5</b>	<b>27</b>	<b>0</b>	<b>0</b>	<b>32</b>	<b>0</b>	<b>34</b>	<b>2</b>	<b>0</b>	<b>36</b>	<b>72</b>

**Comments:**

New housing construction underway west of Longfields Drive. Although this is a 'T' intersection, pedestrians and cyclists were counted on all quadrants. There was a school field trip between 0945 & 1000 resulting in a substantial increase in pedestrian crossings during that time period. Several drivers completely ignored the red pedestrian signal regardless of whether adults or children were waiting to cross Longfields Drive.





# Turning Movement Count Pedestrian Crossings Summary and Flow Diagram



**Longfields Drive & Via Modugno Avenue**

**Nepean, ON**

**Pedestrian Crossings**

**Tuesday, 18 June 2019  
0700-1000 & 1500-1800**

**6 Hour Survey**

**City of Ottawa Ward 3**

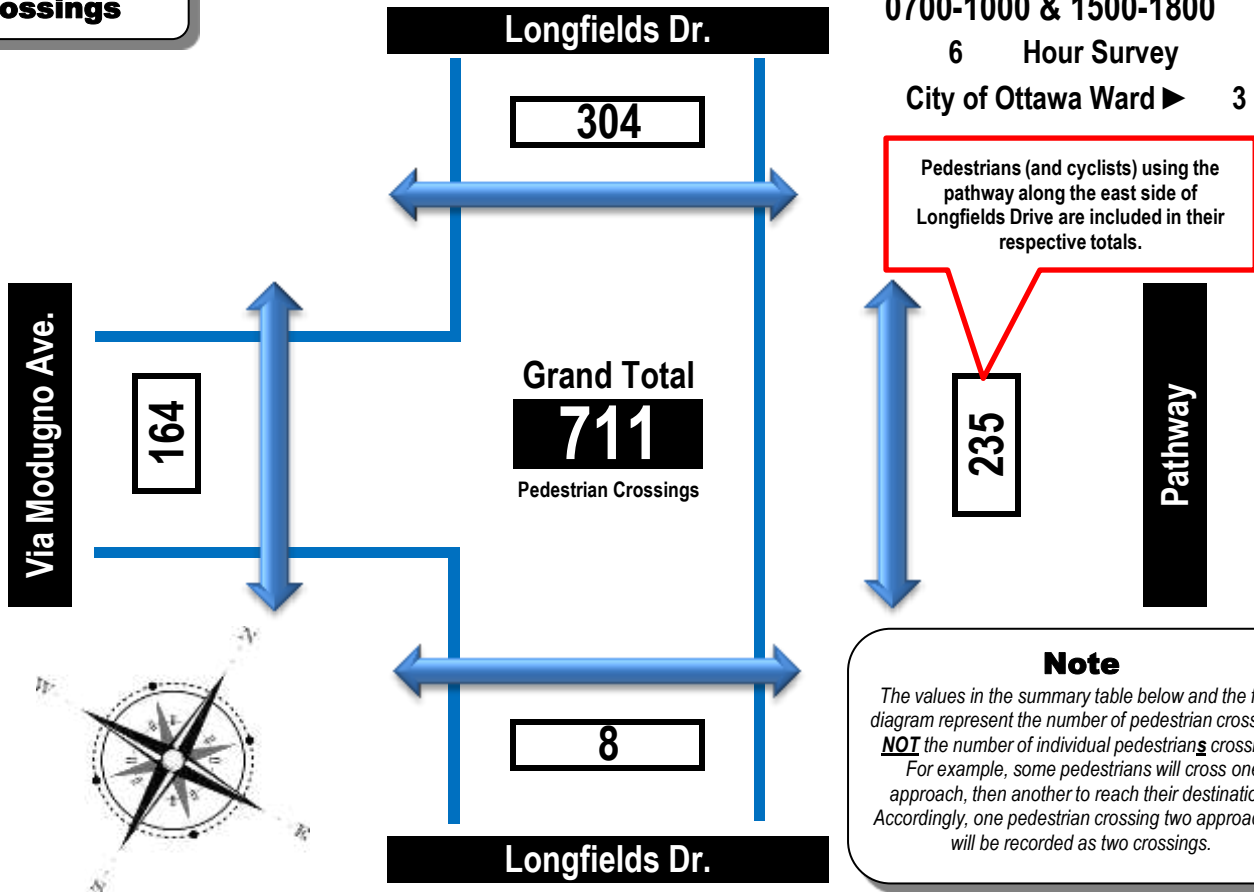

**Note**  
The values in the summary table below and the flow diagram represent the number of pedestrian crossings NOT the number of individual pedestrians crossing. For example, some pedestrians will cross one approach, then another to reach their destination. Accordingly, one pedestrian crossing two approaches will be recorded as two crossings.

Time Period	West Side Crossing Via Modugno Ave.	East Side on Ped/Bike Path	Street Total	South Side Crossing Longfields Dr.	North Side Crossing Longfields Dr.	Street Total	Grand Total
0700-0800	4	7	11	2	14	16	27
0800-0900	16	25	41	0	39	39	80
0900-1000	17	81	98	1	77	78	176
1500-1600	90	77	167	3	122	125	292
1600-1700	24	20	44	2	17	19	63
1700-1800	13	25	38	0	35	35	73
<b>Totals</b>	<b>164</b>	<b>235</b>	<b>399</b>	<b>8</b>	<b>304</b>	<b>312</b>	<b>711</b>

**Comments:**

New housing construction underway west of Longfields Drive. Although this is a 'T' intersection, pedestrians and cyclists were counted on all quadrants. There was a school field trip between 0945 & 1000 resulting in a substantial increase in pedestrian crossings during that time period. Several drivers completely ignored the red pedestrian signal regardless of whether adults or children were waiting to cross Longfields Drive.



# Turning Movement Count Summary Report AADT and Expansion Factors

Automobiles, Taxis,  
Light Trucks, Vans,  
SUV's, Motorcycles,  
Heavy Trucks, Buses,  
and School Buses

## Longfields Drive & Via Modugno Avenue Nepean, ON

**Survey Date:** Tuesday, 18 June 2019      **Start Time:** 0700      **AADT Factor:** 0.9  
**Weather AM:** Clear +12°C      **Survey Duration:** 6 Hrs.      **Survey Hours:** 0700-1000 & 1500-1800  
**Weather PM:** Partly Cloudy +26°C      **Surveyor(s):** Carmody

<b>Via Modugno Ave.</b>	<b>N/A</b>	<b>Longfields Dr.</b>	<b>Longfields Dr.</b>
Eastbound	Westbound	Northbound	Southbound

Time Period	Eastbound					Westbound					W/B Tot	Street Total	Northbound					Southbound					S/B Tot	Street Total	Grand Total
	LT	ST	RT	UT	E/B Tot	LT	ST	RT	UT	LT			ST	RT	UT	N/B Tot	LT	ST	RT	UT					
0700-0800	1	0	15	0	16	0	0	0	0	0	16	8	469	0	0	477	0	253	9	0	262	739	755		
0800-0900	0	0	15	0	15	0	0	0	0	0	15	10	555	0	0	565	0	383	6	0	389	954	969		
0900-1000	2	0	13	0	15	0	0	0	0	0	15	12	247	0	1	260	0	261	5	0	266	526	541		
1500-1600	12	0	27	0	39	0	0	0	0	0	39	14	305	0	0	319	0	486	11	1	498	817	856		
1600-1700	8	0	19	0	27	0	0	0	0	0	27	9	345	0	0	354	0	495	9	1	505	859	886		
1700-1800	5	0	24	0	29	0	0	0	0	0	29	21	401	0	0	422	0	590	13	0	603	1025	1054		
<b>Totals</b>	<b>28</b>	<b>0</b>	<b>113</b>	<b>0</b>	<b>141</b>	<b>0</b>	<b>0</b>	<b>0</b>	<b>0</b>	<b>0</b>	<b>141</b>	<b>74</b>	<b>2322</b>	<b>0</b>	<b>1</b>	<b>2397</b>	<b>0</b>	<b>2468</b>	<b>53</b>	<b>2</b>	<b>2523</b>	<b>4920</b>	<b>5061</b>		

### Equivalent 12 & 24-hour Vehicle Volumes Including the Annual Average Daily Traffic (AADT) Factor Applicable to the Day and Month of the Turning Movement Count

**Expansion factors are applied exclusively to standard weekday 8-hour turning movement counts conducted during the hours of 0700h - 1000h, 1130h - 1330h and 1500h - 1800h**

Equivalent 12-hour vehicle volumes. These volumes are calculated by multiplying the 8-hour totals by the 8 → 12 expansion factor of 1.39																							
Equ. 12 Hr	n/a	n/a	n/a	n/a	n/a	n/a	n/a	n/a	n/a	n/a	n/a	n/a	n/a	n/a	n/a	n/a	n/a	n/a	n/a	n/a	n/a	n/a	n/a
Average daily 12-hour vehicle volumes. These volumes are calculated by multiplying the equivalent 12-hour totals by the AADT factor of: 0.9																							
AADT 12-hr	n/a	n/a	n/a	n/a	n/a	n/a	n/a	n/a	n/a	n/a	n/a	n/a	n/a	n/a	n/a	n/a	n/a	n/a	n/a	n/a	n/a	n/a	n/a
24-Hour AADT. These volumes are calculated by multiplying the average daily 12-hour vehicle volumes by the 12 → 24 expansion factor of 1.31																							
AADT 24 Hr	n/a	n/a	n/a	n/a	n/a	n/a	n/a	n/a	n/a	n/a	n/a	n/a	n/a	n/a	n/a	n/a	n/a	n/a	n/a	n/a	n/a	n/a	n/a

### AADT and expansion factors provided by the City of Ottawa

<b>AM Peak Hour Factor → 0.94</b>											<b>Highest Hourly Vehicle Volume Between 0700h &amp; 1000h</b>												
AM Peak Hr	LT	ST	RT	UT	TOT	LT	ST	RT	UT	TOT	S.TOT	LT	ST	RT	UT	TOT	LT	ST	RT	UT	TOT	S.TOT	G.TOT
0745-0845	0	0	18	0	18	0	0	0	0	0	18	10	571	0	0	581	0	404	11	0	415	996	1014

<b>PM Peak Hour Factor → 0.94</b>											<b>Highest Hourly Vehicle Volume Between 1500h &amp; 1800h</b>												
PM Peak Hr	LT	ST	RT	UT	TOT	LT	ST	RT	UT	TOT	S.TOT	LT	ST	RT	UT	TOT	LT	ST	RT	UT	TOT	S.TOT	G.TOT
1700-1800	5	0	24	0	29	0	0	0	0	0	29	21	401	0	0	422	0	590	13	0	603	1025	1054

#### Comments:

New housing construction underway west of Longfields Drive. Although this is a 'T' intersection, pedestrians and cyclists were counted on all quadrants. There was a school field trip between 0945 & 1000 resulting in a substantial increase in pedestrian crossings during that time period. Several drivers completely ignored the red pedestrian signal regardless of whether adults or children were waiting to cross Longfields Drive.

#### Notes:

1. Includes all vehicle types except bicycles, electric bicycles, and electric scooters.
2. When expansion and AADT factors are applied, the results will differ slightly due to rounding.

# Appendix E

Collision Data

---



# City Operations - Transportation Services

## Collision Details Report - Public Version

**From:** January 1, 2013 **To:** December 31, 2017

**Location:** LONGFIELDS DR @ VIA CAMPANALE AVE

**Traffic Control:** Stop sign

**Total Collisions:** 1

Date/Day/Time	Environment	Impact Type	Classification	Surface Cond'n	Veh. Dir	Vehicle Manoeuvre	Vehicle type	First Event	No. Ped
2015-May-05, Tue,19:04	Clear	Approaching	Non-fatal injury	Dry	West	Going ahead	Automobile, station wagon	Other motor vehicle	
					East	Slowing or stopping	Automobile, station wagon	Other motor vehicle	

**Location:** LONGFIELDS DR @ VIA MODUGNO PL

**Traffic Control:** Stop sign

**Total Collisions:** 1

Date/Day/Time	Environment	Impact Type	Classification	Surface Cond'n	Veh. Dir	Vehicle Manoeuvre	Vehicle type	First Event	No. Ped
2017-Jun-15, Thu,09:12	Clear	SMV other	P.D. only	Dry	East	Turning left	Truck - tractor	Other	

# Appendix F

619 Longfields Dr Site Plan

---



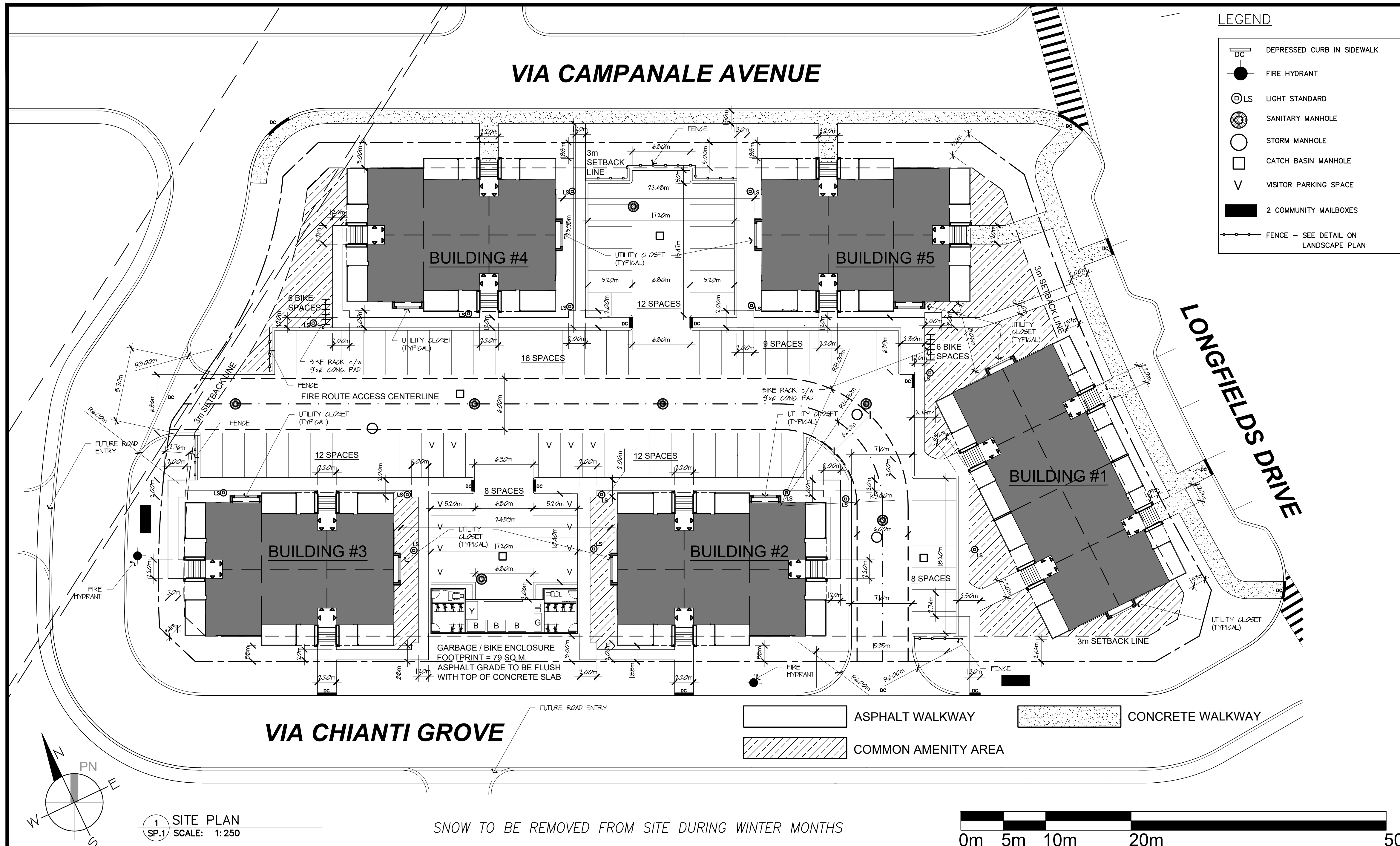

**PLANNED UNIT DEVELOPMENT SUMMARY 591 LONGFIELDS DR.**

- 4 CLUSTERS OF 12 UNIT BLOCKS & 1 CLUSTER OF 16 UNIT BLOCK
- 64 TOTAL PROPOSED RESIDENTIAL UNITS
- 12 UNIT BLOCK FOOTPRINT = 3352m<sup>2</sup>
- 16 UNIT BLOCK FOOTPRINT = 4432m<sup>2</sup>
- 12 UNIT BLOCK GFA = 1229m<sup>2</sup>
- 16 UNIT BLOCK GFA = 1639m<sup>2</sup>

**ZONING SUMMARY (R4A [1774]):**

APPLICABLE 2008-250	CURRENT PROVISION	PROPOSED
MINIMUM LOT WIDTH	30m	N/A
MINIMUM LOT AREA	4046m <sup>2</sup>	6491m <sup>2</sup>
MAXIMUM BUILDING HEIGHT	13m OR 4 STOREYS	13m
MINIMUM FRONT YARD	3m	3m
MINIMUM CORNER YARD	3m	3m
MINIMUM REAR YARD	7.5m	7.5m
MINIMUM INT. SIDE YARD	3m	3m
MAXIMUM RESIDENTIAL DENSITY CALC.	85 UNITS PER ha OF SITE	99 UNITS PER ha OF SITE
MAX # OF UNITS PER STACKED DWELLING UNIT	12	16

**TABLE 162A & EXCEPTION 1774:**

SECTION 101 AND 102 - TOTAL ON SITE [77 SPACES] -

MIN. # OF VISITOR PARKING SPACES PER UNITS	0.2 PER DWELLING UNIT	13 VISITOR SPACES PROVIDED
MIN. # OF PARKING SPACES FOR RESIDENTIAL UNITS	1 PARKING SPACES PER RESIDENTIAL UNIT	64 RESIDENTIAL PARKING SPACES PROVIDED

SECTION 106

PARKING SPACE WIDTH (m)	2.6min-2.75max	2.6min-2.75max
PARKING SPACE DEPTH (m) <td>5.2min. NO MAX</td> <td>5.2min. NO MAX</td>	5.2min. NO MAX	5.2min. NO MAX

SECTION 110

MIN. LANDSCAPE AREA = 15% PARKING LOT AREA	PARKING LOT 2177m <sup>2</sup> x 0.15 = 326.6m <sup>2</sup> MIN.	1962m <sup>2</sup> LANDSCAPE AREA
LANDSCAPE BUFFER FOR PARKING LOT NOT ABUTTING A STREET	1.5m	1.5m
MIN. LANDSCAPE BUFFER FOR PARKING LOT ABUTTING A STREET	3.0m	3.0m

SECTION 111

BICYCLE PARKING SPACE REQUIRED PER RESIDENTIAL UNIT	0.5 PER UNIT	0.5 x 68 UNITS = 34 TOTAL 12 OUTDOOR 22 INDOOR
---	--------------	--

SECTION 137

TOTAL AMENITY AREA REQUIRED PER UNIT	6m <sup>2</sup> PER DWELLING UNIT = 408m <sup>2</sup>	EACH DWELLING BALCONY IS 9m <sup>2</sup> MIN. = 9x(66)=612m <sup>2</sup>
COMMON AMENITY REQUIRED	MIN. 50% OF REQ. TOTAL AMENITY AREA (204m <sup>2</sup> )	435m <sup>2</sup> AMENITY AREA (HATCHED)

TABLE 131 - APPLICABLE PUD PROVISIONS

(1) MINIMUM WIDTH OF DRIVEWAY - 6m  
 (2) THE MINIMUM SETBACK FOR ANY WALL OF A RESIDENTIAL USE BUILDING TO A PRIVATE WAY IS 1.8m  
 (5)(b) REQUIRED VISITOR PARKING MAY BE PROVIDED AS PARALLEL PARKING ON A PRIVATE WAS, PROVIDED THERE IS A MINIMUM ROAD WIDTH OF 8.5m

1. Contractor must verify all job dimensions, all drawings, details, specifications and report any discrepancies to owners before proceeding with work.  
 2. All drawings and specifications are instruments of service and the property of the architects which must be returned at the completion of the work, and may not be reproduced without their written permission.

ref	description	date
2	2nd SUBMISSION	FEB. 27, 2017
1	SITE PLAN CONTROL APPLICATION	OCT. 06, 2016



**CAMPANALE HOMES**  
 1187 BANK STREET, SUITE 200  
 OTTAWA, ONTARIO, K1S 3X7  
 tel: 613 730 7000  
 fax: 613 730 3030



**PAUL A. COOPER ARCHITECT**  
 76 CHAMBERLAIN AVE.  
 OTTAWA, ONTARIO  
 K1S 1V9  
 (819) 685 9512 Tel



**STANTEC / WEBSTER & SIMMONDS SURVEYING LTD**  
 1505 LAPERRIERE AVE.  
 OTTAWA, ONTARIO  
 tel: 613 722 4420  
 fax: 613 722 0769

2 GARBAGE/BIKE ENCLOSURE 79m<sup>2</sup> FOOTPRINT  
 SP.1 SCALE: 1:100

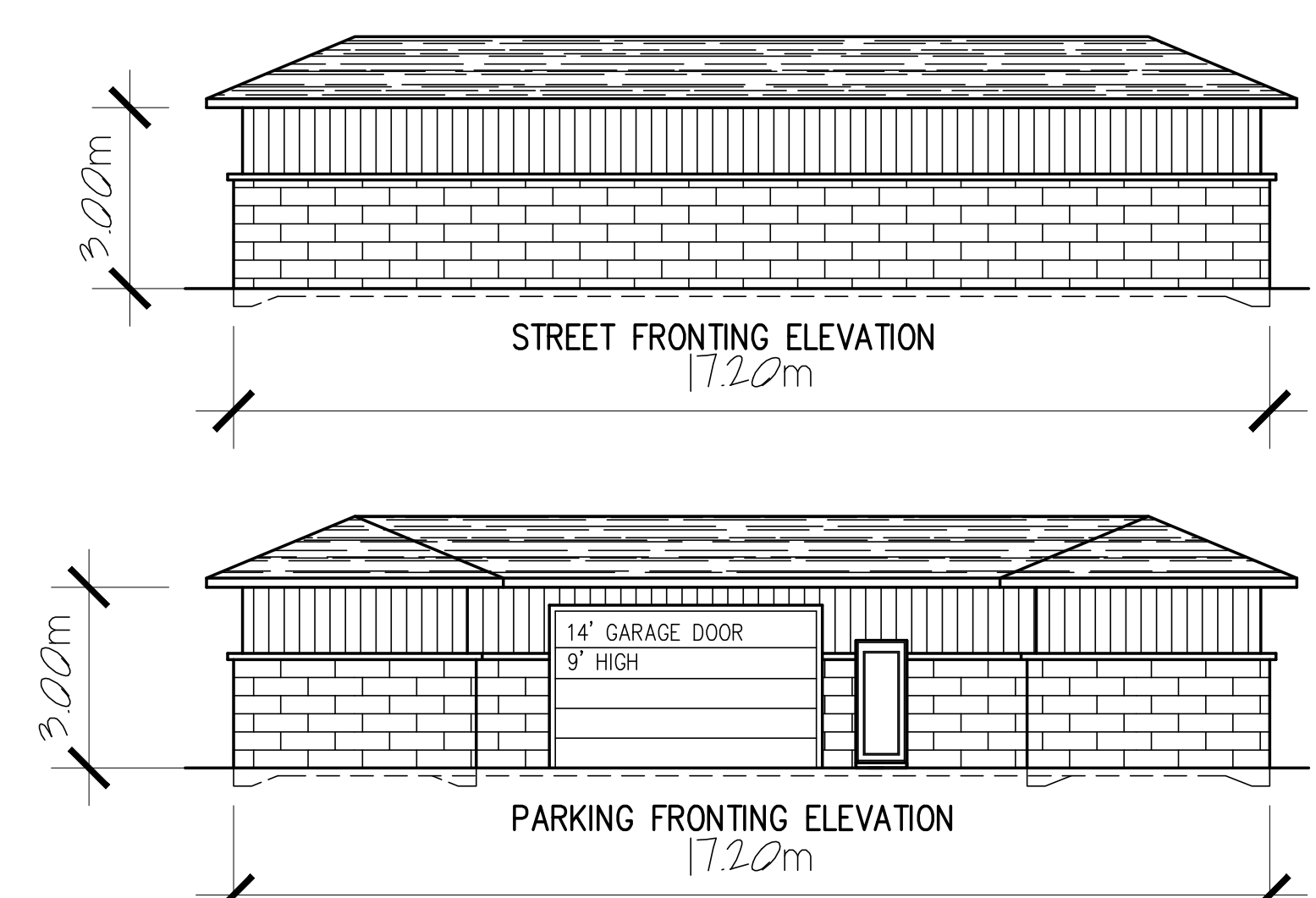

SNOW TO BE REMOVED FROM SITE DURING WINTER MONTHS



3 TOE WALL DETAILS  
 SP.1 SCALE: N.T.S.

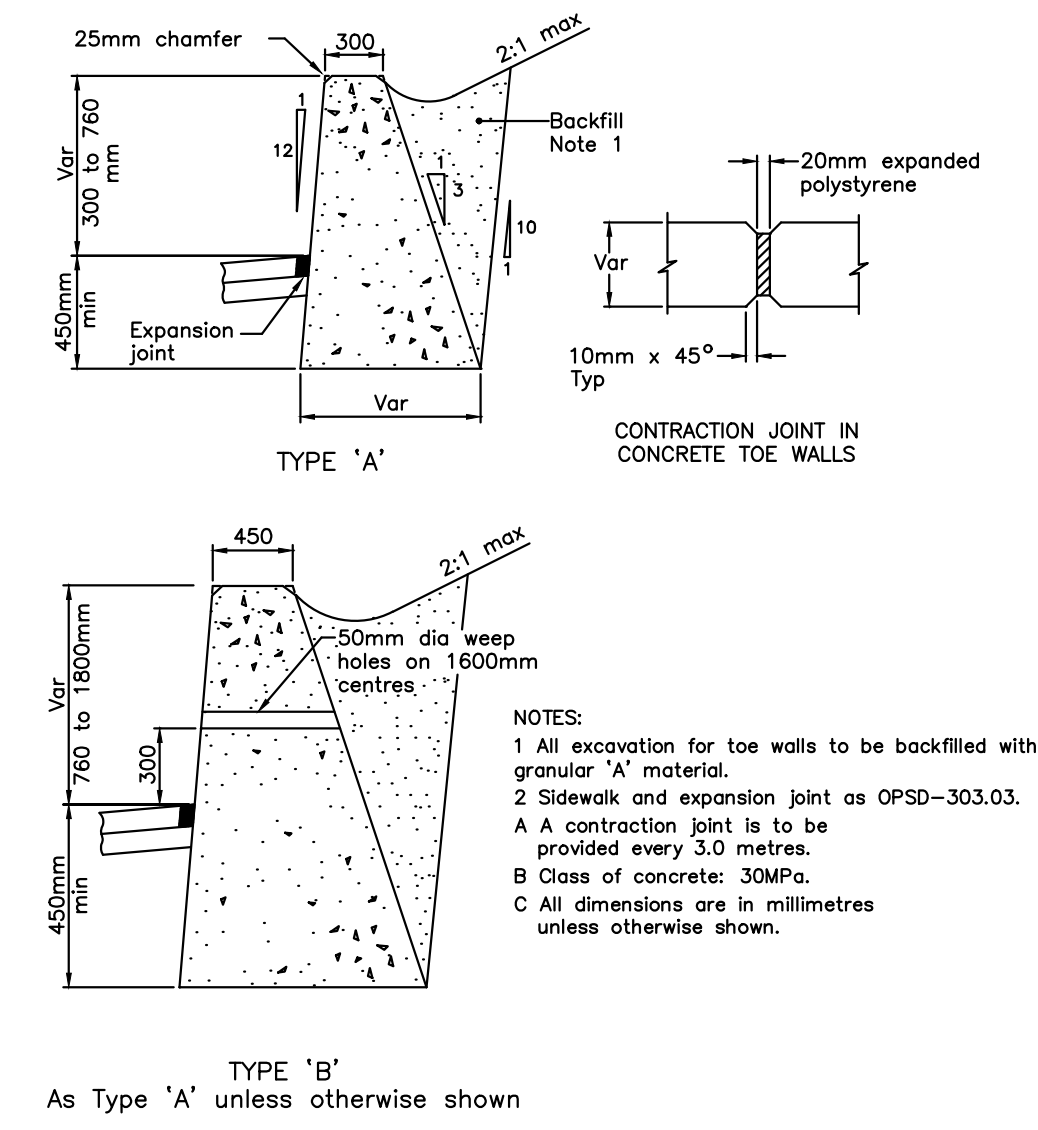

4 KEY PLAN  
 SP.1 SCALE: N.T.S.

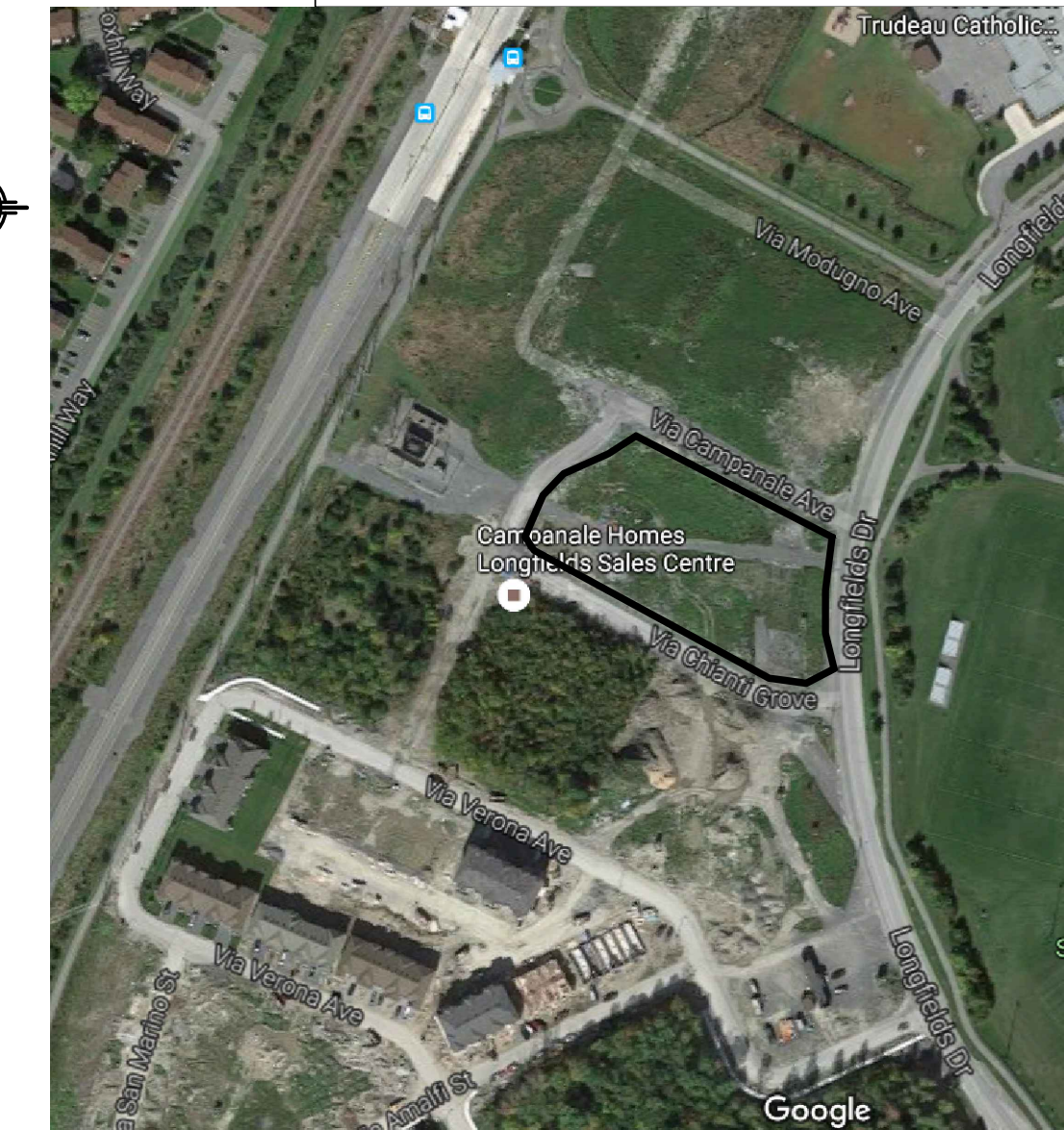
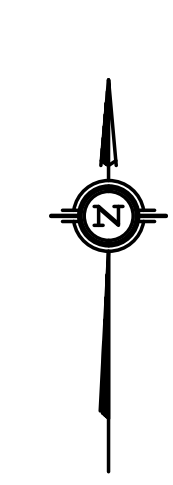

**LONGFIELDS STATION URBAN TERRACE HOMES**  
 619 LONGFIELDS DRIVE  
 OTTAWA, ONTARIO

title of drawing  
**SITE PLAN**  
 city file number  
 D07-12-16-0156

scale  
 1:250  
 date  
 OCT 2016  
 drawn by  
 AJ

**SP-1**



# Appendix G

Trip Generation Calculations

---

**TRANS Trip Generation for Low-Rise Apartments (2 floors) with a Total of 28 Dwelling Units**

Travel Mode	AM Mode Share	AM Peak (persons/h)			PM Mode Share	PM Peak (persons/h)		
		In	Out	Total		In	Out	Total
Auto Driver	35%	1	7	8	35%	6	4	10
Auto Passenger	15%	1	2	3	15%	3	2	5
Transit	35%	1	7	8	35%	6	4	10
Non-motorized	15%	1	3	4	15%	3	2	5
<b>Total People Trips</b>	<b>100%</b>	<b>4</b>	<b>19</b>	<b>23</b>	<b>100%</b>	<b>18</b>	<b>12</b>	<b>30</b>
<b>Total 'New' TRANS Trip Generation for Low-Rise Apartments (2 floors) with a Total of 28 Dwelling Units Auto Trips</b>		<b>1</b>	<b>7</b>	<b>8</b>		<b>6</b>	<b>4</b>	<b>10</b>

**ITE Trip Generation for 15,000 sq. ft. Commercial Use**

Travel Mode	Mode Share	AM Peak (Person Trips/hr)			PM Peak (Person Trips/hr)		
		In	Out	Total	In	Out	Total
Auto Driver	15%	0	0	0	5	7	12
Auto Passenger	5%	0	0	0	2	2	4
Transit	15%	0	0	0	5	6	11
Non-motorized	65%	0	0	0	20	27	47
<b>Total Person Trips</b>	<b>100%</b>	<b>0</b>	<b>0</b>	<b>0</b>	<b>32</b>	<b>42</b>	<b>74</b>
Less Pass-by (0%)		0	0	0	0	0	0
<b>Total 'New' ITE Trip Generation for 15,000 sq. ft. Commercial Use Auto Trips</b>		<b>0</b>	<b>0</b>	<b>0</b>	<b>5</b>	<b>7</b>	<b>12</b>

**Total Trips Generated by Proposed Future Development**

Travel Mode	AM Peak (persons/h)			PM Peak (persons/h)		
	In	Out	Total	In	Out	Total
Auto Driver	1	7	8	11	11	22
Auto Passenger	1	2	3	5	4	9
Transit	1	7	8	11	10	21
Non-motorized	1	3	4	23	29	52
<b>Total People Trips</b>	<b>4</b>	<b>19</b>	<b>23</b>	<b>50</b>	<b>54</b>	<b>104</b>
<b>Total 'New' Auto Trips</b>	<b>1</b>	<b>7</b>	<b>8</b>	<b>11</b>	<b>11</b>	<b>22</b>

# Appendix H

Detailed Background Growth Analysis

---

Longfields/ Mountshannon  
AM Peak

Year	Date	North Leg		South Leg		East Leg		West Leg		Total
		SB	NB	NB	SB	WB	EB	EB	WB	
2012	30-Aug	125	73	16	142	185	242	318	187	1288
2013	31-May	80	92	11	36	96	262	347	144	1068
2019	18-Jun					415	571	581	422	1989

Year	Counts				% Change			
	NB	SB	NB+SB	INT	NB	SB	NB+SB	INT
2012	73	125	198	1288				
2013	92	80	172	1068	26.0%	-36.0%	-13.1%	-17.1%
2019				1989				86.2%

Regression Estimate 2012  
 Regression Estimate 2019  
 Average Annual Change

Year	Counts				% Change			
	EB	WB	EB+WB	INT	EB	WB	EB+WB	INT
2012	318	187	505	1288				
2013	347	144	491	1068	9.1%	-23.0%	-2.8%	-17.1%
2019	581	422	1003	1989	67.4%	193.1%	104.3%	86.2%

Regression Estimate 2012 314 150 463  
 Regression Estimate 2019 580 416 996  
 Average Annual Change 9.18% 15.72% 11.55%

Year	Counts				% Change			
	EB	WB	EB+WB	INT	EB	WB	EB+WB	INT
2012	242	185	427	1288				
2013	262	96	358	1068	8.3%	-48.1%	-16.2%	-17.1%
2019	571	415	986	1989	117.9%	332.3%	175.4%	86.2%

Regression Estimate 2012 229 125 354  
 Regression Estimate 2019 569 405 974  
 Average Annual Change 13.89% 18.22% 15.54%

Year	Counts				% Change			
	NB	SB	NB+SB	INT	NB	SB	NB+SB	INT
2012	16	142	158	1288				
2013	11	36	47	1068	-31.3%	-74.6%	-70.3%	-17.1%
2019				1989				86.2%

Regression Estimate 2012  
 Regression Estimate 2019  
 Average Annual Change

Longfields/ Mountshannon  
PM Peak

Year	Date	North Leg		South Leg		East Leg		West Leg		Total
		SB	NB	NB	SB	WB	EB	EB	WB	
2012	30-Aug	164	153	9	114	199	160	327	272	1398
2013	31-May	121	111	4	8	207	177	261	297	1186
2019	18-Jun					603	406	422	614	2045

Year	Counts				% Change			
	NB	SB	NB+SB	INT	NB	SB	NB+SB	INT
2012	153	164	317	1398				
2013	111	121	232	1186	-27.5%	-26.2%	-26.8%	-15.2%
2019				2045				72.4%

Regression Estimate 2012  
Regression Estimate 2019  
Average Annual Change

Year	Counts				% Change			
	EB	WB	EB+WB	INT	EB	WB	EB+WB	INT
2012	327	272	599	1398				
2013	261	297	558	1186	-20.2%	9.2%	-6.8%	-15.2%
2019	422	614	1036	2045	61.7%	106.7%	85.7%	72.4%

Regression Estimate 2012 288 260 548  
Regression Estimate 2019 416 612 1028  
Average Annual Change 5.37% 12.99% 9.38%

Year	Counts				% Change			
	EB	WB	EB+WB	INT	EB	WB	EB+WB	INT
2012	160	199	359	1398				
2013	177	207	384	1186	10.6%	4.0%	7.0%	-15.2%
2019	406	603	1009	2045	129.4%	191.3%	162.8%	72.4%

Regression Estimate 2012 151 175 326  
Regression Estimate 2019 405 599 1003  
Average Annual Change 15.10% 19.24% 17.43%

Year	Counts				% Change			
	NB	SB	NB+SB	INT	NB	SB	NB+SB	INT
2012	9	114	123	1398				
2013	4	8	12	1186	-55.6%	-93.0%	-90.2%	-15.2%
2019				2045				72.4%

Regression Estimate 2012  
Regression Estimate 2019  
Average Annual Change

# Appendix I

Stopping Sight Distances

---



Stopping Site Distance - North Access  
Assumed Operating Speed 40km/h  
~50m (per TAC-Table 2.5.2)  
Oct. 11 2019

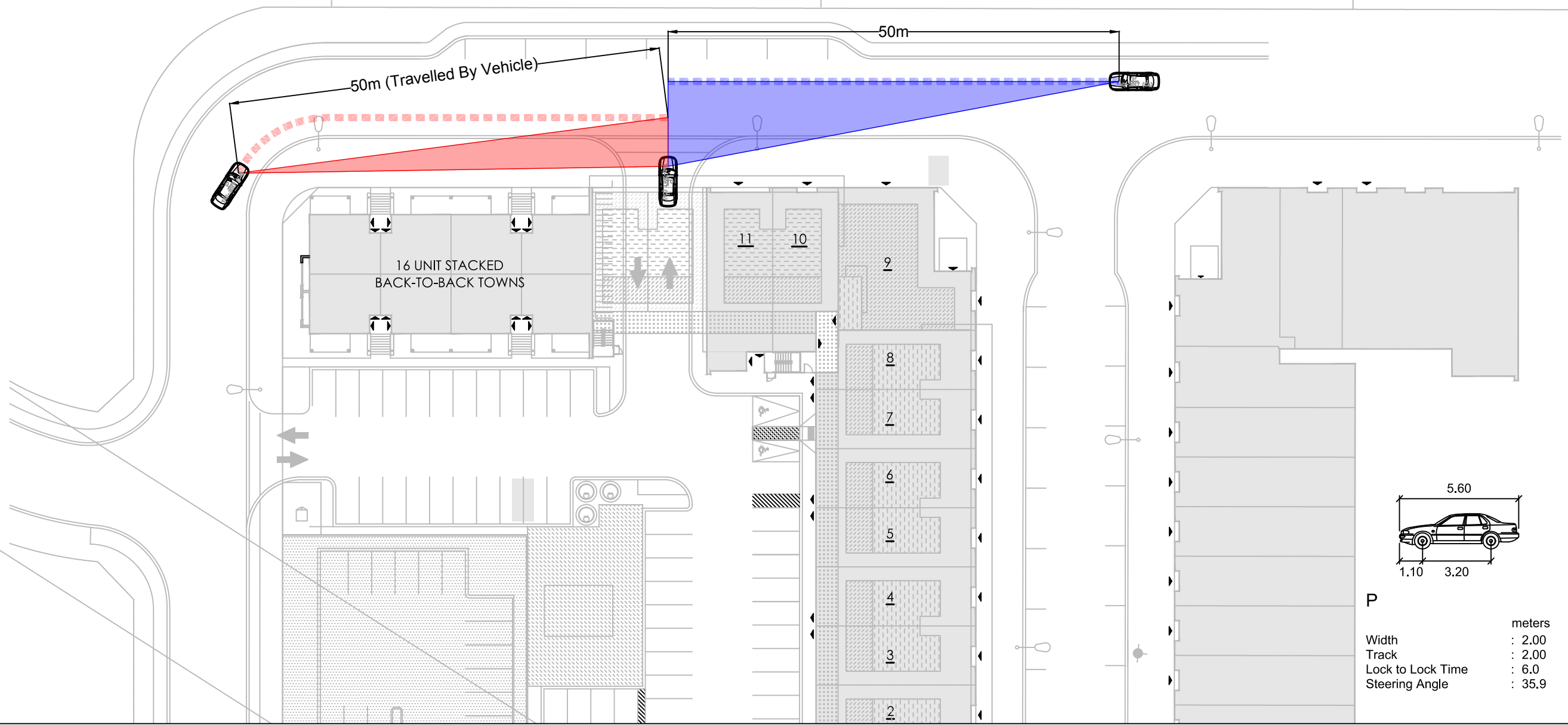

Stopping Site Distance - West Access Corner  
 Assumed Operating Speed 30km/h  
 ~35m (per TAC-Table 2.5.2)  
 Oct. 11 2019

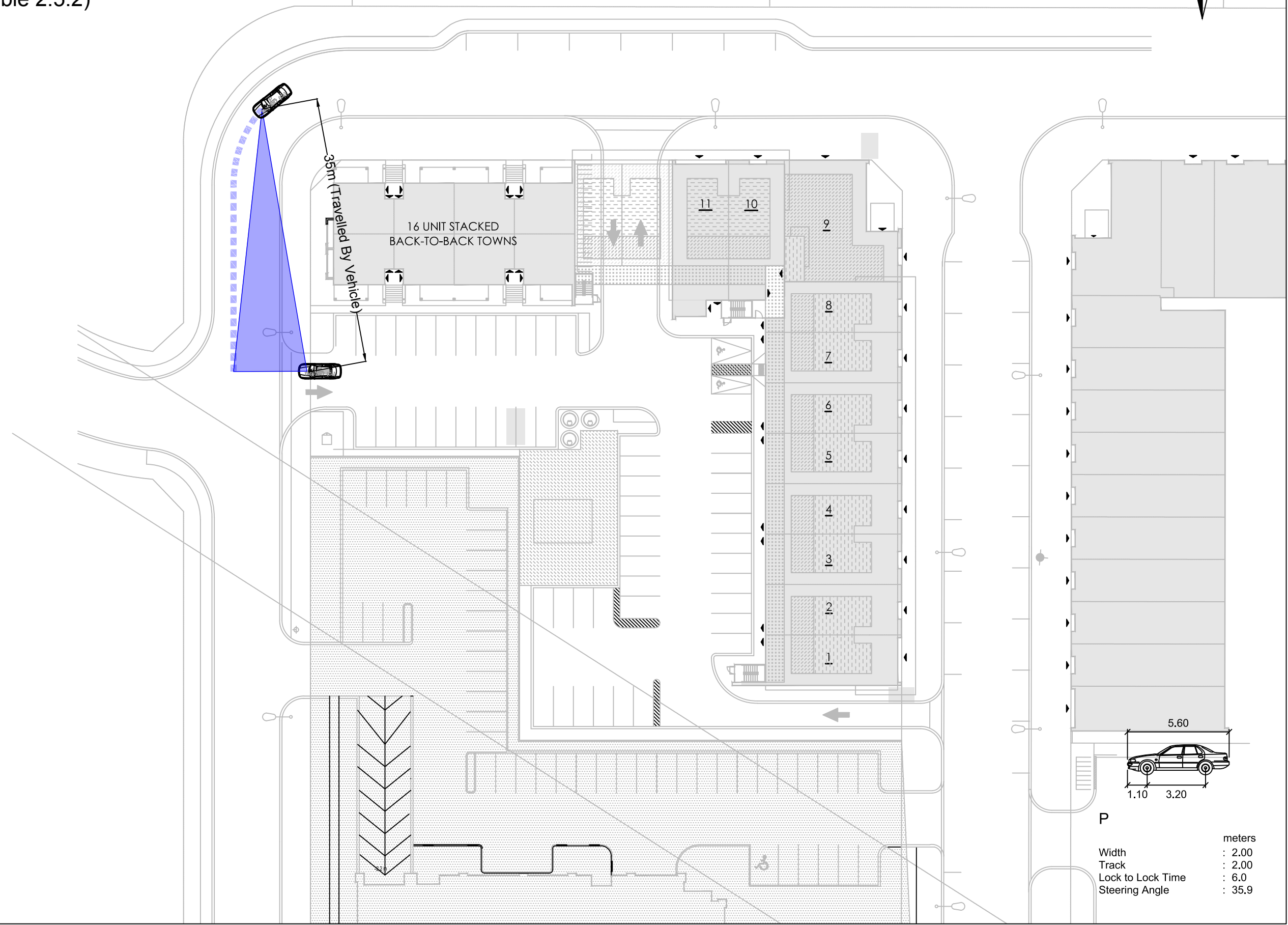
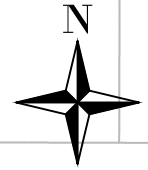

Stopping Site Distance - West Access  
 Assumed Operating Speed 40km/h  
 ~50m (per TAC-Table 2.5.2)  
 Oct. 11 2019

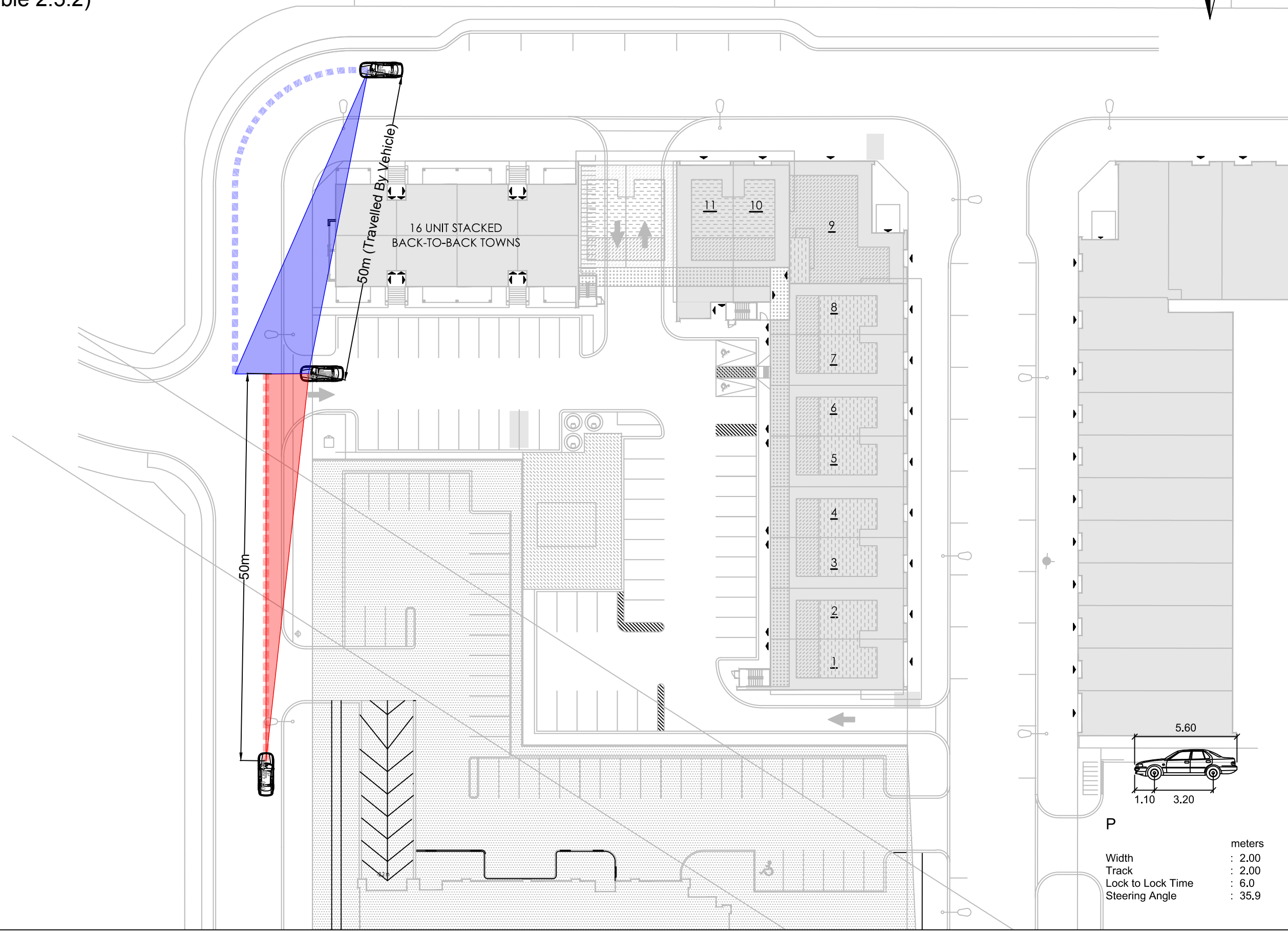
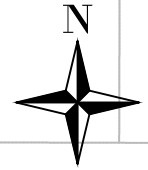

# Appendix J

MMLoS Analysis

---

# Multi-Modal Level of Service - Segments Form

Consultant	PARSONS	Project	477167 - 01000
Scenario	TIA Step 4	Date	Aug-19
Comments	Block 14		

SEGMENTS		Street A	Via Campanale West Frontage	Via Campanale North Frontage	Via Modugno East Frontage
Pedestrian	Sidewalk Width	-	≥ 2 m	≥ 2 m	≥ 2 m
	Boulevard Width		< 0.5	< 0.5	< 0.5
	Avg Daily Curb Lane Traffic Volume		≤ 3000	≤ 3000	≤ 3000
	Operating Speed		≤ 30 km/h	≤ 30 km/h	≤ 30 km/h
	On-Street Parking		no	no	yes
	<b>Exposure to Traffic PLoS</b>		<b>A</b>	<b>A</b>	<b>A</b>
	Effective Sidewalk Width				
Pedestrian Volume					
<b>Crowding PLoS</b>	<b>-</b>	<b>-</b>	<b>-</b>		
<b>Level of Service</b>	<b>-</b>	<b>-</b>	<b>-</b>		
Bicycle	Type of Cycling Facility	A	Mixed Traffic	Mixed Traffic	Mixed Traffic
	Number of Travel Lanes		≤ 2 (no centreline)	≤ 2 (no centreline)	≤ 2 (no centreline)
	Operating Speed		≤ 40 km/h	≤ 40 km/h	≤ 40 km/h
	<b># of Lanes &amp; Operating Speed LoS</b>		<b>A</b>	<b>A</b>	<b>A</b>
	Bike Lane (+ Parking Lane) Width				
	<b>Bike Lane Width LoS</b>		<b>-</b>	<b>-</b>	<b>-</b>
	Bike Lane Blockages				
	<b>Blockage LoS</b>		<b>-</b>	<b>-</b>	<b>-</b>
	Median Refuge Width (no median = < 1.8 m)		< 1.8 m refuge	< 1.8 m refuge	< 1.8 m refuge
	No. of Lanes at Unsignalized Crossing		≤ 3 lanes	≤ 3 lanes	≤ 3 lanes
Sidestreet Operating Speed	≤ 40 km/h	≤ 40 km/h	≤ 40 km/h		
<b>Unsignalized Crossing - Lowest LoS</b>	<b>A</b>	<b>A</b>	<b>A</b>		
<b>Level of Service</b>	<b>A</b>	<b>A</b>	<b>A</b>		
Transit	Facility Type	D	Mixed Traffic	Mixed Traffic	Mixed Traffic
	Friction or Ratio Transit:Posted Speed		Vt/Vp ≥ 0.8	Vt/Vp ≥ 0.8	Vt/Vp ≥ 0.8
	<b>Level of Service</b>		<b>D</b>	<b>D</b>	<b>D</b>
Truck	Truck Lane Width	B	> 3.7 m	> 3.7 m	> 3.7 m
	Travel Lanes per Direction		1	1	1
	<b>Level of Service</b>		<b>B</b>	<b>B</b>	<b>B</b>

# Appendix K

Synchro Analysis: Existing Conditions

---



Existing AM  
1: Longfields Dr & Via Modugno PI

09/11/2019



Movement	EBL	EBR	NBL	NBT	SBT	SBR
Lane Configurations						
Traffic Volume (veh/h)	0	18	10	571	404	11
Future Volume (Veh/h)	0	18	10	571	404	11
Sign Control	Stop			Free	Free	
Grade	0%			0%	0%	
Peak Hour Factor	0.90	0.90	0.90	0.90	0.90	0.90
Hourly flow rate (vph)	0	20	11	634	449	12
Pedestrians	16			39		
Lane Width (m)	3.7			3.7		
Walking Speed (m/s)	1.1			1.1		
Percent Blockage	1			4		
Right turn flare (veh)						
Median type				None	None	
Median storage veh						
Upstream signal (m)						
pX, platoon unblocked						
vC, conflicting volume	1166	471	477			
vC1, stage 1 conf vol						
vC2, stage 2 conf vol						
vCu, unblocked vol	1166	471	477			
tC, single (s)	6.4	6.2	4.1			
tC, 2 stage (s)						
tF (s)	3.5	3.3	2.2			
p0 queue free %	100	97	99			
cM capacity (veh/h)	201	584	1069			
Direction, Lane #	EB 1	NB 1	SB 1			
Volume Total	20	645	461			
Volume Left	0	11	0			
Volume Right	20	0	12			
cSH	584	1069	1700			
Volume to Capacity	0.03	0.01	0.27			
Queue Length 95th (m)	0.8	0.2	0.0			
Control Delay (s)	11.4	0.3	0.0			
Lane LOS	B	A				
Approach Delay (s)	11.4	0.3	0.0			
Approach LOS	B					
<b>Intersection Summary</b>						
Average Delay			0.4			
Intersection Capacity Utilization			50.2%	ICU Level of Service	A	
Analysis Period (min)			15			

Existing AM  
2: Longfields Dr & Via Campanale Ave

09/11/2019



Movement	EBL	EBR	NBL	NBT	SBT	SBR
Lane Configurations						
Traffic Volume (veh/h)	2	7	20	574	421	1
Future Volume (Veh/h)	2	7	20	574	421	1
Sign Control	Stop			Free	Free	
Grade	0%			0%	0%	
Peak Hour Factor	0.90	0.90	0.90	0.90	0.90	0.90
Hourly flow rate (vph)	2	8	22	638	468	1
Pedestrians	5			2	4	
Lane Width (m)	3.7			3.7	3.7	
Walking Speed (m/s)	1.1			1.1	1.1	
Percent Blockage	0			0	0	
Right turn flare (veh)						
Median type				None	None	
Median storage veh						
Upstream signal (m)						
pX, platoon unblocked						
vC, conflicting volume	1160	476	474			
vC1, stage 1 conf vol						
vC2, stage 2 conf vol						
vCu, unblocked vol	1160	476	474			
tC, single (s)	6.4	6.2	4.1			
tC, 2 stage (s)						
tF (s)	3.5	3.3	2.2			
p0 queue free %	99	99	98			
cM capacity (veh/h)	210	585	1083			
Direction, Lane #	EB 1	NB 1	SB 1			
Volume Total	10	660	469			
Volume Left	2	22	0			
Volume Right	8	0	1			
cSH	431	1083	1700			
Volume to Capacity	0.02	0.02	0.28			
Queue Length 95th (m)	0.5	0.5	0.0			
Control Delay (s)	13.5	0.5	0.0			
Lane LOS	B	A				
Approach Delay (s)	13.5	0.5	0.0			
Approach LOS	B					
Intersection Summary						
Average Delay			0.4			
Intersection Capacity Utilization			59.6%	ICU Level of Service	B	
Analysis Period (min)			15			

Existing PM  
1: Longfields Dr & Via Modugno PI

09/11/2019



Movement	EBL	EBR	NBL	NBT	SBT	SBR
Lane Configurations						
Traffic Volume (veh/h)	5	24	21	401	590	13
Future Volume (Veh/h)	5	24	21	401	590	13
Sign Control	Stop			Free	Free	
Grade	0%			0%	0%	
Peak Hour Factor	0.90	0.90	0.90	0.90	0.90	0.90
Hourly flow rate (vph)	6	27	23	446	656	14
Pedestrians	13			35		
Lane Width (m)	3.7			3.7		
Walking Speed (m/s)	1.1			1.1		
Percent Blockage	1			3		
Right turn flare (veh)						
Median type				None	None	
Median storage veh						
Upstream signal (m)						
pX, platoon unblocked						
vC, conflicting volume	1203	676	683			
vC1, stage 1 conf vol						
vC2, stage 2 conf vol						
vCu, unblocked vol	1203	676	683			
tC, single (s)	6.4	6.2	4.1			
tC, 2 stage (s)						
tF (s)	3.5	3.3	2.2			
p0 queue free %	97	94	97			
cM capacity (veh/h)	190	448	899			
Direction, Lane #	EB 1	NB 1	SB 1			
Volume Total	33	469	670			
Volume Left	6	23	0			
Volume Right	27	0	14			
cSH	359	899	1700			
Volume to Capacity	0.09	0.03	0.39			
Queue Length 95th (m)	2.3	0.6	0.0			
Control Delay (s)	16.0	0.7	0.0			
Lane LOS	C	A				
Approach Delay (s)	16.0	0.7	0.0			
Approach LOS	C					
<b>Intersection Summary</b>						
Average Delay	0.8					
Intersection Capacity Utilization	50.4%			ICU Level of Service	A	
Analysis Period (min)	15					

Existing PM  
2: Longfields Dr & Via Campanale Ave

09/11/2019



Movement	EBL	EBR	NBL	NBT	SBT	SBR
Lane Configurations						
Traffic Volume (veh/h)	4	19	14	422	606	7
Future Volume (Veh/h)	4	19	14	422	606	7
Sign Control	Stop			Free	Free	
Grade	0%			0%	0%	
Peak Hour Factor	0.90	0.90	0.90	0.90	0.90	0.90
Hourly flow rate (vph)	4	21	16	469	673	8
Pedestrians	5					
Lane Width (m)	3.7					
Walking Speed (m/s)	1.1					
Percent Blockage	0					
Right turn flare (veh)						
Median type				None	None	
Median storage (veh)						
Upstream signal (m)						
pX, platoon unblocked						
vC, conflicting volume	1183	682	686			
vC1, stage 1 conf vol						
vC2, stage 2 conf vol						
vCu, unblocked vol	1183	682	686			
tC, single (s)	6.4	6.2	4.1			
tC, 2 stage (s)						
tF (s)	3.5	3.3	2.2			
p0 queue free %	98	95	98			
cM capacity (veh/h)	205	448	903			
<b>Direction, Lane #</b>	<b>EB 1</b>	<b>NB 1</b>	<b>SB 1</b>			
Volume Total	25	485	681			
Volume Left	4	16	0			
Volume Right	21	0	8			
cSH	376	903	1700			
Volume to Capacity	0.07	0.02	0.40			
Queue Length 95th (m)	1.6	0.4	0.0			
Control Delay (s)	15.2	0.5	0.0			
Lane LOS	C	A				
Approach Delay (s)	15.2	0.5	0.0			
Approach LOS	C					
<b>Intersection Summary</b>						
Average Delay			0.5			
Intersection Capacity Utilization			45.4%	ICU Level of Service	A	
Analysis Period (min)			15			

# Appendix L

Synchro Analysis: Total Future Background 2020 Conditions

---

Total Future Background 2020 AM  
1: Longfields Dr & Via Modugno PI

09/11/2019



Movement	EBL	EBR	NBL	NBT	SBT	SBR
Lane Configurations						
Traffic Volume (veh/h)	5	27	22	602	424	17
Future Volume (Veh/h)	5	27	22	602	424	17
Sign Control	Stop			Free	Free	
Grade	0%			0%	0%	
Peak Hour Factor	1.00	1.00	1.00	1.00	1.00	1.00
Hourly flow rate (vph)	5	27	22	602	424	17
Pedestrians	16			39		
Lane Width (m)	3.7			3.7		
Walking Speed (m/s)	1.1			1.1		
Percent Blockage	1			4		
Right turn flare (veh)						
Median type				None	None	
Median storage veh						
Upstream signal (m)						
pX, platoon unblocked						
vC, conflicting volume	1134	448	457			
vC1, stage 1 conf vol						
vC2, stage 2 conf vol						
vCu, unblocked vol	1134	448	457			
tC, single (s)	6.4	6.2	4.1			
tC, 2 stage (s)						
tF (s)	3.5	3.3	2.2			
p0 queue free %	98	96	98			
cM capacity (veh/h)	209	601	1087			
Direction, Lane #	EB 1	NB 1	SB 1			
Volume Total	32	624	441			
Volume Left	5	22	0			
Volume Right	27	0	17			
cSH	465	1087	1700			
Volume to Capacity	0.07	0.02	0.26			
Queue Length 95th (m)	1.7	0.5	0.0			
Control Delay (s)	13.3	0.5	0.0			
Lane LOS	B	A				
Approach Delay (s)	13.3	0.5	0.0			
Approach LOS	B					
<b>Intersection Summary</b>						
Average Delay	0.7					
Intersection Capacity Utilization	62.2%			ICU Level of Service	B	
Analysis Period (min)	15					

Total Future Background 2020 AM  
2: Longfields Dr & Via Campanale Ave

09/11/2019



Movement	EBL	EBR	NBL	NBT	SBT	SBR
Lane Configurations						
Traffic Volume (veh/h)	5	7	20	603	442	2
Future Volume (Veh/h)	5	7	20	603	442	2
Sign Control	Stop			Free	Free	
Grade	0%			0%	0%	
Peak Hour Factor	1.00	1.00	1.00	1.00	1.00	1.00
Hourly flow rate (vph)	5	7	20	603	442	2
Pedestrians	5			2	4	
Lane Width (m)	3.7			3.7	3.7	
Walking Speed (m/s)	1.1			1.1	1.1	
Percent Blockage	0			0	0	
Right turn flare (veh)						
Median type				None	None	
Median storage veh						
Upstream signal (m)						
pX, platoon unblocked						
vC, conflicting volume	1095	450	449			
vC1, stage 1 conf vol						
vC2, stage 2 conf vol						
vCu, unblocked vol	1095	450	449			
tC, single (s)	6.4	6.2	4.1			
tC, 2 stage (s)						
tF (s)	3.5	3.3	2.2			
p0 queue free %	98	99	98			
cM capacity (veh/h)	230	605	1106			
Direction, Lane #	EB 1	NB 1	SB 1			
Volume Total	12	623	444			
Volume Left	5	20	0			
Volume Right	7	0	2			
cSH	361	1106	1700			
Volume to Capacity	0.03	0.02	0.26			
Queue Length 95th (m)	0.8	0.4	0.0			
Control Delay (s)	15.3	0.5	0.0			
Lane LOS	C	A				
Approach Delay (s)	15.3	0.5	0.0			
Approach LOS	C					
<b>Intersection Summary</b>						
Average Delay	0.5					
Intersection Capacity Utilization	61.2%			ICU Level of Service	B	
Analysis Period (min)	15					



Total Future Background 2020 PM  
1: Longfields Dr & Via Modugno PI

09/11/2019



Movement	EBL	EBR	NBL	NBT	SBT	SBR
Lane Configurations						
Traffic Volume (veh/h)	14	43	34	421	621	20
Future Volume (Veh/h)	14	43	34	421	621	20
Sign Control	Stop			Free	Free	
Grade	0%			0%	0%	
Peak Hour Factor	1.00	1.00	1.00	1.00	1.00	1.00
Hourly flow rate (vph)	14	43	34	421	621	20
Pedestrians	13				35	
Lane Width (m)	3.7				3.7	
Walking Speed (m/s)	1.1				1.1	
Percent Blockage	1				3	
Right turn flare (veh)						
Median type				None	None	
Median storage veh						
Upstream signal (m)						
pX, platoon unblocked						
vC, conflicting volume	1168	644	654			
vC1, stage 1 conf vol						
vC2, stage 2 conf vol						
vCu, unblocked vol	1168	644	654			
tC, single (s)	6.4	6.2	4.1			
tC, 2 stage (s)						
tF (s)	3.5	3.3	2.2			
p0 queue free %	93	91	96			
cM capacity (veh/h)	197	467	922			
<b>Direction, Lane #</b>	<b>EB 1</b>	<b>NB 1</b>	<b>SB 1</b>			
Volume Total	57	455	641			
Volume Left	14	34	0			
Volume Right	43	0	20			
cSH	349	922	1700			
Volume to Capacity	0.16	0.04	0.38			
Queue Length 95th (m)	4.4	0.9	0.0			
Control Delay (s)	17.3	1.1	0.0			
Lane LOS	C	A				
Approach Delay (s)	17.3	1.1	0.0			
Approach LOS	C					
<b>Intersection Summary</b>						
Average Delay			1.3			
Intersection Capacity Utilization			63.3%	ICU Level of Service	B	
Analysis Period (min)			15			

Total Future Background 2020 PM  
2: Longfields Dr & Via Campanale Ave

09/11/2019



Movement	EBL	EBR	NBL	NBT	SBT	SBR
Lane Configurations						
Traffic Volume (veh/h)	6	19	14	443	636	10
Future Volume (Veh/h)	6	19	14	443	636	10
Sign Control	Stop			Free	Free	
Grade	0%			0%	0%	
Peak Hour Factor	1.00	1.00	1.00	1.00	1.00	1.00
Hourly flow rate (vph)	6	19	14	443	636	10
Pedestrians	5					
Lane Width (m)	3.7					
Walking Speed (m/s)	1.1					
Percent Blockage	0					
Right turn flare (veh)						
Median type				None	None	
Median storage veh						
Upstream signal (m)						
pX, platoon unblocked						
vC, conflicting volume	1117	646	651			
vC1, stage 1 conf vol						
vC2, stage 2 conf vol						
vCu, unblocked vol	1117	646	651			
tC, single (s)	6.4	6.2	4.1			
tC, 2 stage (s)						
tF (s)	3.5	3.3	2.2			
p0 queue free %	97	96	98			
cM capacity (veh/h)	225	469	931			
<b>Direction, Lane #</b>	<b>EB 1</b>	<b>NB 1</b>	<b>SB 1</b>			
Volume Total	25	457	646			
Volume Left	6	14	0			
Volume Right	19	0	10			
cSH	372	931	1700			
Volume to Capacity	0.07	0.02	0.38			
Queue Length 95th (m)	1.6	0.3	0.0			
Control Delay (s)	15.4	0.4	0.0			
Lane LOS	C	A				
Approach Delay (s)	15.4	0.4	0.0			
Approach LOS	C					
<b>Intersection Summary</b>						
Average Delay			0.5			
Intersection Capacity Utilization			46.5%	ICU Level of Service	A	
Analysis Period (min)			15			

# Appendix M

---

Synchro Analysis: Total Future Background 2025 Conditions

Total Future Background 2025 AM  
1: Longfields Dr & Via Modugno PI

09/11/2019



Movement	EBL	EBR	NBL	NBT	SBT	SBR
Lane Configurations						
Traffic Volume (veh/h)	5	27	22	744	525	17
Future Volume (Veh/h)	5	27	22	744	525	17
Sign Control	Stop			Free	Free	
Grade	0%			0%	0%	
Peak Hour Factor	1.00	1.00	1.00	1.00	1.00	1.00
Hourly flow rate (vph)	5	27	22	744	525	17
Pedestrians	16			39		
Lane Width (m)	3.7			3.7		
Walking Speed (m/s)	1.1			1.1		
Percent Blockage	1			4		
Right turn flare (veh)						
Median type				None	None	
Median storage veh						
Upstream signal (m)						
pX, platoon unblocked						
vC, conflicting volume	1376	550	558			
vC1, stage 1 conf vol						
vC2, stage 2 conf vol						
vCu, unblocked vol	1376	550	558			
tC, single (s)	6.4	6.2	4.1			
tC, 2 stage (s)						
tF (s)	3.5	3.3	2.2			
p0 queue free %	97	95	98			
cM capacity (veh/h)	148	527	998			
Direction, Lane #	EB 1	NB 1	SB 1			
Volume Total	32	766	542			
Volume Left	5	22	0			
Volume Right	27	0	17			
cSH	377	998	1700			
Volume to Capacity	0.08	0.02	0.32			
Queue Length 95th (m)	2.1	0.5	0.0			
Control Delay (s)	15.4	0.6	0.0			
Lane LOS	C	A				
Approach Delay (s)	15.4	0.6	0.0			
Approach LOS	C					
<b>Intersection Summary</b>						
Average Delay			0.7			
Intersection Capacity Utilization			70.1%	ICU Level of Service	C	
Analysis Period (min)			15			

Total Future Background 2025 AM  
2: Longfields Dr & Via Campanale Ave

09/11/2019



Movement	EBL	EBR	NBL	NBT	SBT	SBR
Lane Configurations						
Traffic Volume (veh/h)	5	7	20	746	547	2
Future Volume (Veh/h)	5	7	20	746	547	2
Sign Control	Stop			Free	Free	
Grade	0%			0%	0%	
Peak Hour Factor	1.00	1.00	1.00	1.00	1.00	1.00
Hourly flow rate (vph)	5	7	20	746	547	2
Pedestrians	5			2	4	
Lane Width (m)	3.7			3.7	3.7	
Walking Speed (m/s)	1.1			1.1	1.1	
Percent Blockage	0			0	0	
Right turn flare (veh)						
Median type				None	None	
Median storage veh						
Upstream signal (m)						
pX, platoon unblocked						
vC, conflicting volume	1343	555	554			
vC1, stage 1 conf vol						
vC2, stage 2 conf vol						
vCu, unblocked vol	1343	555	554			
tC, single (s)	6.4	6.2	4.1			
tC, 2 stage (s)						
tF (s)	3.5	3.3	2.2			
p0 queue free %	97	99	98			
cM capacity (veh/h)	163	528	1012			
Direction, Lane #	EB 1	NB 1	SB 1			
Volume Total	12	766	549			
Volume Left	5	20	0			
Volume Right	7	0	2			
cSH	273	1012	1700			
Volume to Capacity	0.04	0.02	0.32			
Queue Length 95th (m)	1.0	0.5	0.0			
Control Delay (s)	18.8	0.5	0.0			
Lane LOS	C	A				
Approach Delay (s)	18.8	0.5	0.0			
Approach LOS	C					
<b>Intersection Summary</b>						
Average Delay	0.5					
Intersection Capacity Utilization	69.1%			ICU Level of Service	C	
Analysis Period (min)	15					

Total Future Background 2025 PM  
1: Longfields Dr & Via Modugno PI

09/11/2019



Movement	EBL	EBR	NBL	NBT	SBT	SBR
Lane Configurations						
Traffic Volume (veh/h)	14	43	34	521	768	20
Future Volume (Veh/h)	14	43	34	521	768	20
Sign Control	Stop			Free	Free	
Grade	0%			0%	0%	
Peak Hour Factor	1.00	1.00	1.00	1.00	1.00	1.00
Hourly flow rate (vph)	14	43	34	521	768	20
Pedestrians	13			35		
Lane Width (m)	3.7			3.7		
Walking Speed (m/s)	1.1			1.1		
Percent Blockage	1			3		
Right turn flare (veh)						
Median type				None	None	
Median storage veh						
Upstream signal (m)						
pX, platoon unblocked						
vC, conflicting volume	1415	791	801			
vC1, stage 1 conf vol						
vC2, stage 2 conf vol						
vCu, unblocked vol	1415	791	801			
tC, single (s)	6.4	6.2	4.1			
tC, 2 stage (s)						
tF (s)	3.5	3.3	2.2			
p0 queue free %	90	89	96			
cM capacity (veh/h)	139	385	812			
Direction, Lane #	EB 1	NB 1	SB 1			
Volume Total	57	555	788			
Volume Left	14	34	0			
Volume Right	43	0	20			
cSH	268	812	1700			
Volume to Capacity	0.21	0.04	0.46			
Queue Length 95th (m)	6.0	1.0	0.0			
Control Delay (s)	22.0	1.1	0.0			
Lane LOS	C	A				
Approach Delay (s)	22.0	1.1	0.0			
Approach LOS	C					
Intersection Summary						
Average Delay			1.3			
Intersection Capacity Utilization			68.7%	ICU Level of Service	C	
Analysis Period (min)			15			

Total Future Background 2025 PM  
2: Longfields Dr & Via Campanale Ave

09/11/2019



Movement	EBL	EBR	NBL	NBT	SBT	SBR
Lane Configurations						
Traffic Volume (veh/h)	6	19	14	549	788	10
Future Volume (Veh/h)	6	19	14	549	788	10
Sign Control	Stop			Free	Free	
Grade	0%			0%	0%	
Peak Hour Factor	1.00	1.00	1.00	1.00	1.00	1.00
Hourly flow rate (vph)	6	19	14	549	788	10
Pedestrians	5					
Lane Width (m)	3.7					
Walking Speed (m/s)	1.1					
Percent Blockage	0					
Right turn flare (veh)						
Median type				None	None	
Median storage (veh)						
Upstream signal (m)						
pX, platoon unblocked						
vC, conflicting volume	1375	798	803			
vC1, stage 1 conf vol						
vC2, stage 2 conf vol						
vCu, unblocked vol	1375	798	803			
tC, single (s)	6.4	6.2	4.1			
tC, 2 stage (s)						
tF (s)	3.5	3.3	2.2			
p0 queue free %	96	95	98			
cM capacity (veh/h)	157	384	817			
Direction, Lane #	EB 1	NB 1	SB 1			
Volume Total	25	563	798			
Volume Left	6	14	0			
Volume Right	19	0	10			
cSH	285	817	1700			
Volume to Capacity	0.09	0.02	0.47			
Queue Length 95th (m)	2.2	0.4	0.0			
Control Delay (s)	18.8	0.5	0.0			
Lane LOS	C	A				
Approach Delay (s)	18.8	0.5	0.0			
Approach LOS	C					
<b>Intersection Summary</b>						
Average Delay	0.5					
Intersection Capacity Utilization	54.4%			ICU Level of Service	A	
Analysis Period (min)	15					