

APPROXIMATE PIECE WEIGHT (TONNES)			
	REBAR	CONCRETE	TOTAL
TOP	2.085	33.435	35.790
BOTTOM	2.085	33.435	35.790
TOTAL	4.170	66.870	71.040

TOP VIEW
1:50

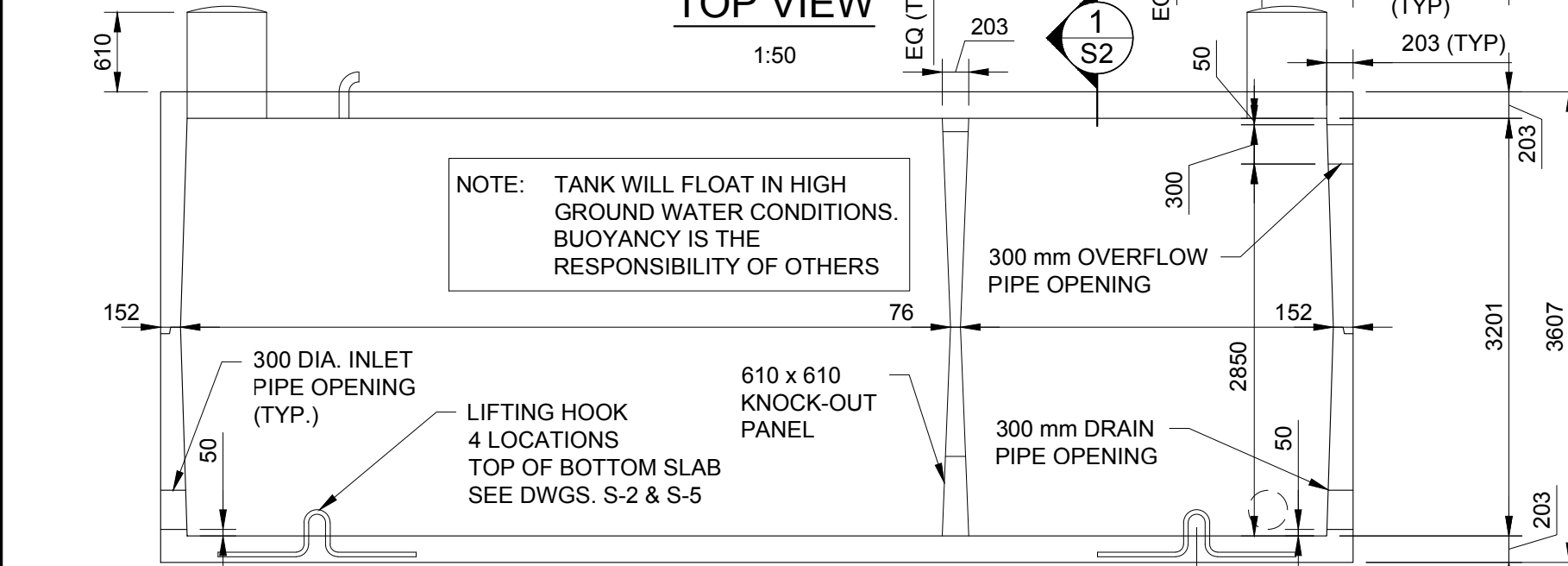

SIDE VIEW
1:50

GENERAL NOTES:

- ALL DIMENSIONS ARE IN MILLIMETERS UNLESS NOTED OTHERWISE.
- PRECAST CONCRETE TANK DESIGNED TO 2012 ONTARIO BUILDING CODE CSA B66-16. BEDDING, WATERPROOFING, BACKFILL, AND ALL OTHER SITE WORK BY OTHERS.
- CONCRETE WORK TO BE IN ACCORDANCE WITH CAN/CSA A23.1 CONCRETE MATERIALS AND METHODS OF CONCRETE CONSTRUCTION, AND CAN/CSA A23.4 PRECAST CONCRETE MATERIALS AND CONSTRUCTION.
- BOX DESIGNED FOR A MAXIMUM FILL HEIGHT OF 760 mm WITH 15 kPa LIVE LOAD. DESIGN FILL COVER ON THIS TANK IS 610 mm.
- CONCRETE TO BE 45 MPa SCC WITH 600 mm ±70 mm SLUMP.
- CONCRETE COVER AS NOTED, WITH ±10 mm TOLERANCE.
- REINFORCING STEEL TO BE GRADE 400W BLACK DEFORMED BARS CONFORMING TO CAN/CSA G30.18.
- DO NOT LIFT UNITS UNTIL CONCRETE HAS REACHED A MINIMUM STRENGTH OF 25 MPa, AS DETERMINED BY COMPRESSIVE TESTING OF CONCRETE CYLINDERS CURED IN SIMILAR CONDITIONS.
- GROUT TO BE NON-SHRINK CEMENTITIOUS GROUT WITH MINIMUM COMPRESSIVE STRENGTH OF 45 MPa.
- JOINT SEAL TO BE CONSEAL CS-102 BUTYL RUBBER SEALANT (CONFORMS TO AASHTO M-198B AND ASTM C-990-91). STORE, HANDLE AND APPLY JOINT SEALS IN STRICT ACCORDANCE WITH MANUFACTURER PRODUCT DATA SHEETS.
- IT IS STRUCTURALLY IMPORTANT THAT THE SEALS IN THE HORIZONTAL JOINTS BE INSTALLED CORRECTLY. TOP PIECES MUST BE INSTALLED WITHOUT SLIDING THE PIECES ON THE SEALS.
- DESIGN BASED ON GRANULAR BEDDING AND BACKFILL COMPACTED TO 95% SPDD.
- LIFTING INSERTS TO BE GROUTED ON SITE BY OTHERS.
- DELIVERY IS MADE BY CRANE-EQUIPPED TRUCKS.
- EXCAVATION MUST BE READY, SAFE AND ACCESSIBLE FOR UNLOADING FROM THE REAR OF THE TRUCK.
- MINIMUM OVERHEAD CLEARANCE OF 18 FT. IS REQUIRED.
- ALL UNITS MUST BE HANDLED WITH PROPER LIFTING EQUIPMENT (i.e. SPREADER BARS).

McINTOSH PERRY
115 Walgreen Road, RR3, Carp, ON K0A 1L0
Tel: 613-836-2184 Fax: 613-836-3742
www.mcintoshperry.com

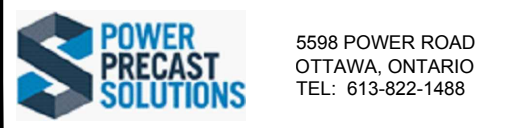

Version	Description	YYYY-MM-DD
2	REVISED FOR 15KPA LIVE LOAD	2022-07-08
1	ISSUED FOR REVIEW	2018-08-31

Stamp

McIntosh Perry

Stamp

WELLINGS OF STITTSVILLE
PPS JOB NO.: 2018-0803
MH JOB NO.: 2170737.34

TANK DIMENSIONS		
Scale 1:50		
DWG No. S-1	Version 1	Date 2018-08-28

\\ot01fp\data1\shared\proj\2170737\CAD\PRECAST_CULVERT_BLOCKS.dwg

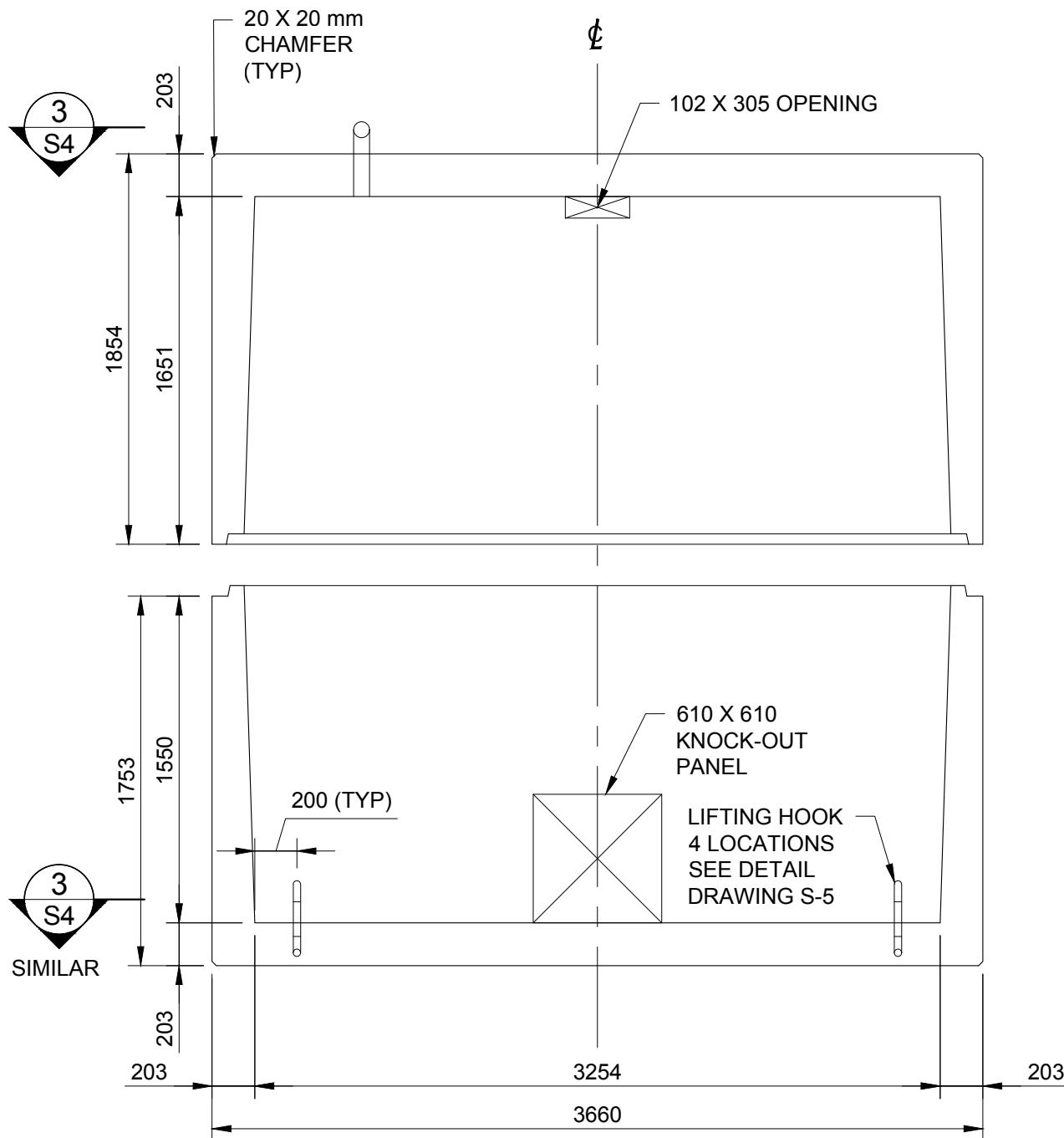

END VIEW

1:30

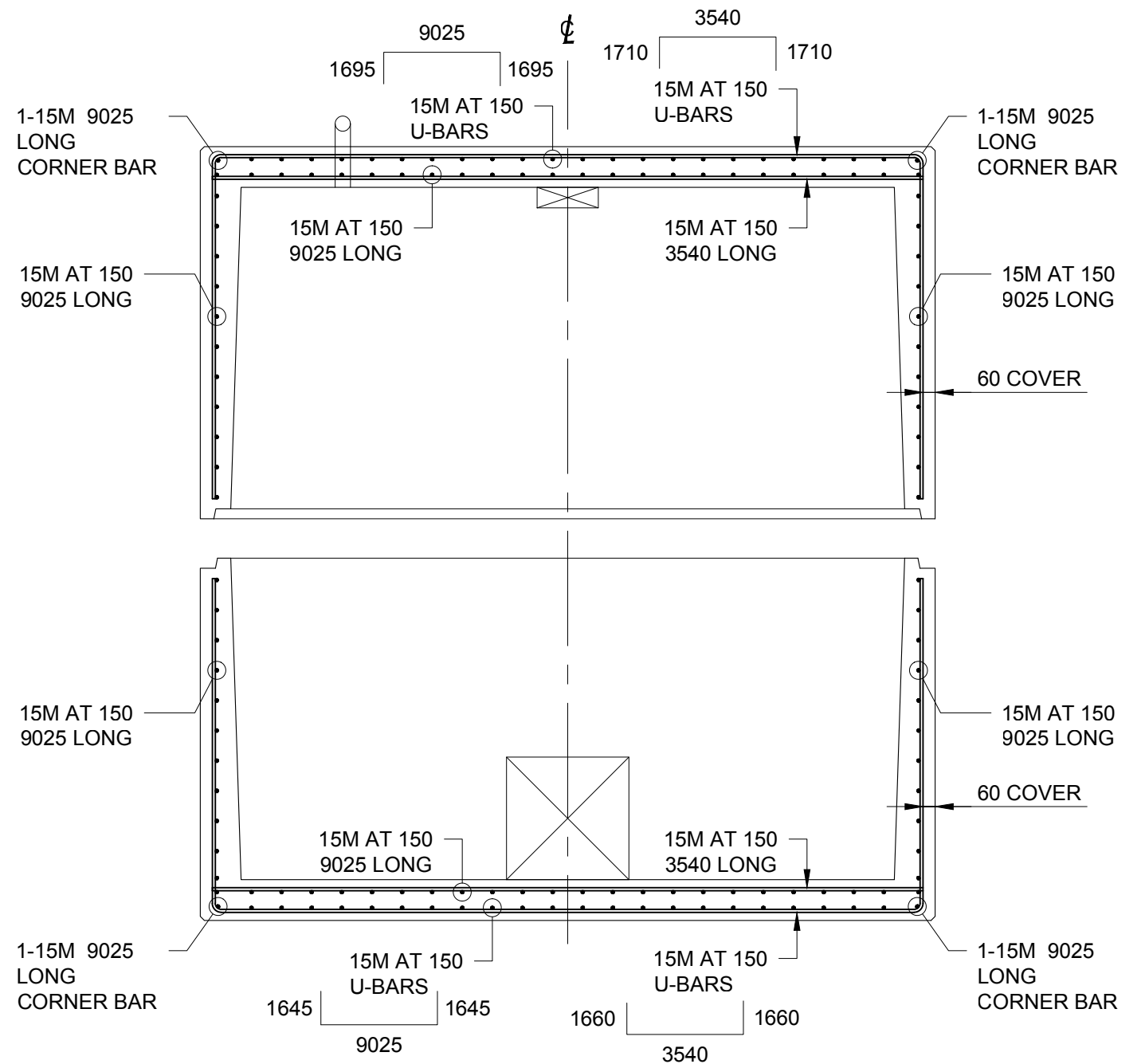

SECTION 1

1:30

McINTOSH PERRY

115 Walgreen Road, RR3, Carp, ON K0A 1L0
Tel: 613-836-2184 Fax: 613-836-3742
www.mcintoshperry.com



5598 POWER ROAD
OTTAWA, ONTARIO
TEL: 613-822-1488

Version	Description	YYYY-MM-DD
2	REVISED FOR 15KPA LIVE LOAD	2022-07-08
1	ISSUED FOR REVIEW	2018-08-31

Stamp



McIntosh Perry

WELLINGS OF STITTSVILLE

PPS JOB NO.: 2018-0803
MH JOB NO.: 2170737.34

SECTIONS

Scale
AS NOTED

DWG No.	Version	Date
S-2	1	2018-08-28

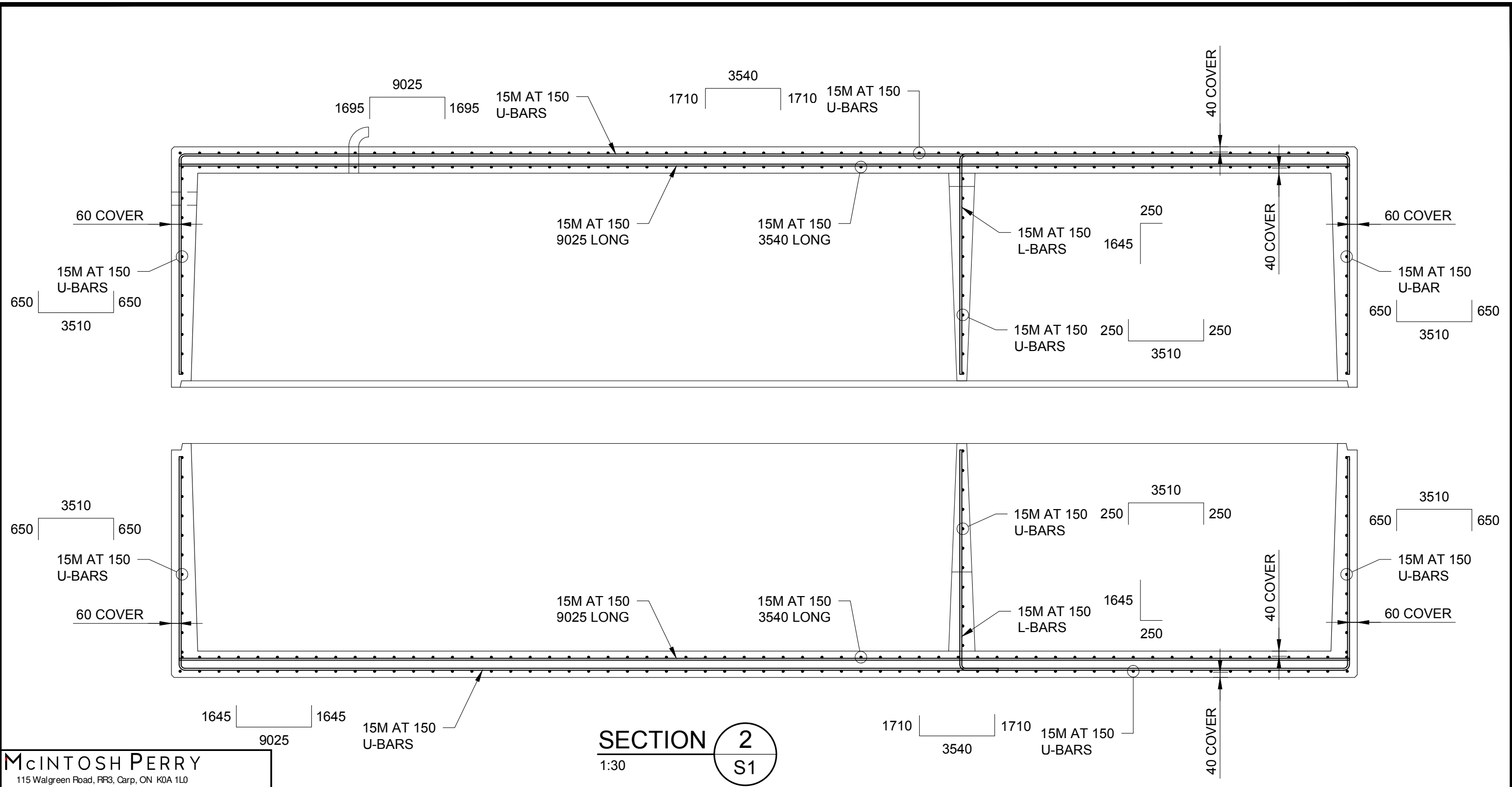

McINTOSH PERRY
 115 Walgreen Road, RR3, Carp, ON K0A 1L0
 Tel: 613-836-2184 Fax: 613-836-3742
 www.mcintoshperry.com

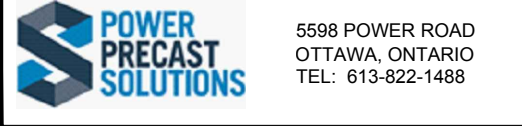

5598 POWER ROAD
 OTTAWA, ONTARIO
 TEL: 613-822-1488

Version	Description	YYYY-MM-DD
2	REVISED FOR 15KPA LIVE LOAD	2022-07-08
1	ISSUED FOR REVIEW	2018-08-31

Stamp

McIntosh Perry

WELLINGS OF STITTSVILLE

PPS JOB NO.: 2018-0803
 MH JOB NO.: 2170737.34

SECTIONS		
Scale AS NOTED		
DWG No. S-3	Version 1	Date 2018-08-28

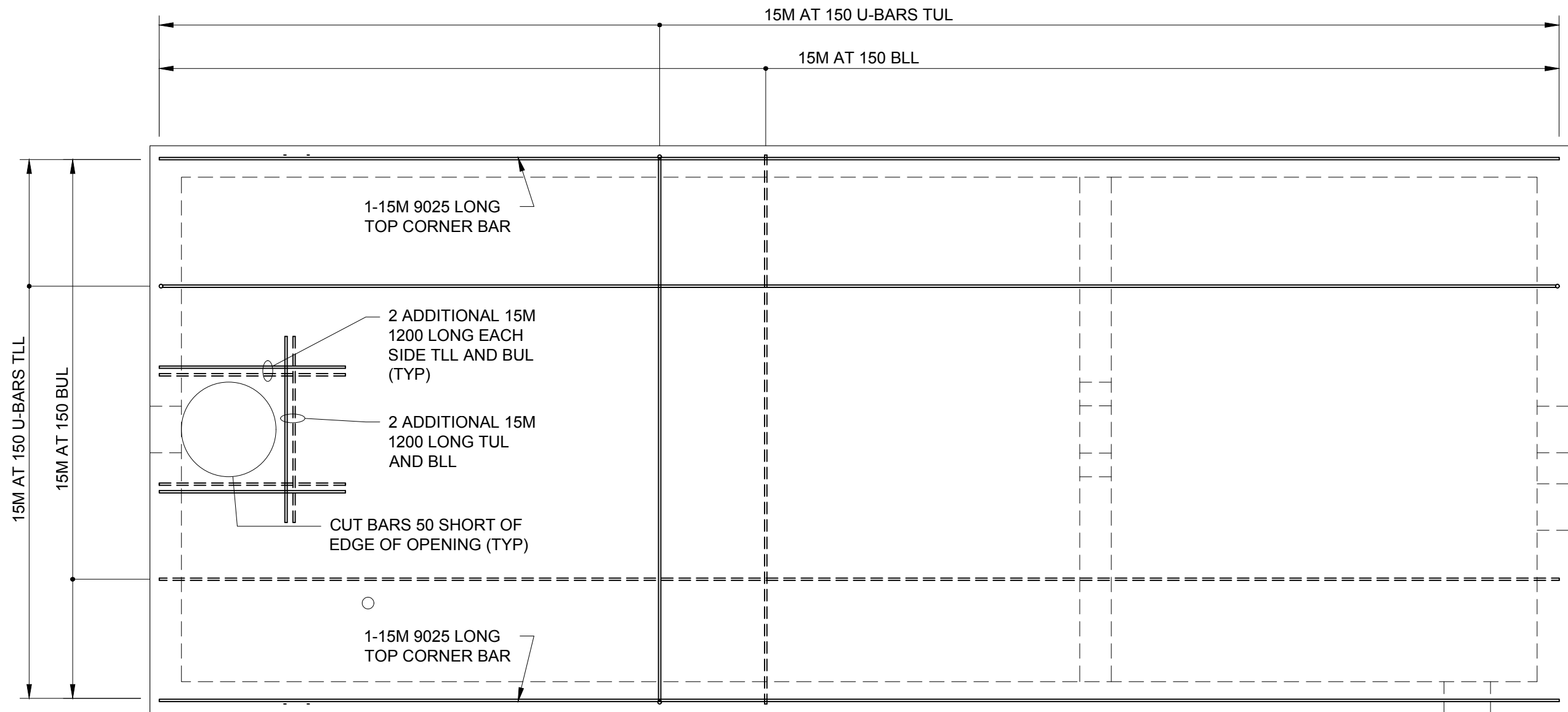

SECTION 3
1:30 S2

LEGEND

- DENOTES TOP MAT BARS
- ===== DENOTES BOTTOM MAT BARS
- TUL TOP UPPER LAYER
- TLL TOP LOWER LAYER
- BUL BOTTOM UPPER LAYER
- BLL BOTTOM LOWER LAYER

McINTOSH PERRY
115 Walgreen Road, RR3, Carp, ON K0A 1L0
Tel: 613-836-2184 Fax: 613-836-3742
www.mcintoshperry.com

MORRISON HERSHFIELD

POWER PRECAST SOLUTIONS
5598 POWER ROAD
OTTAWA, ONTARIO
TEL: 613-822-1488

Version	Description	YYYY-MM-DD
2	REVISED FOR 15KPA LIVE LOAD	2022-07-08
1	ISSUED FOR REVIEW	2018-08-31

Stamp

McIntosh Perry

WELLINGS OF STITTSVILLE

PPS JOB NO.: 2018-0803
MH JOB NO.: 2170737.34

SECTIONS		
Scale AS NOTED		
DWG No. S-4	Version 1	Date 2018-08-28

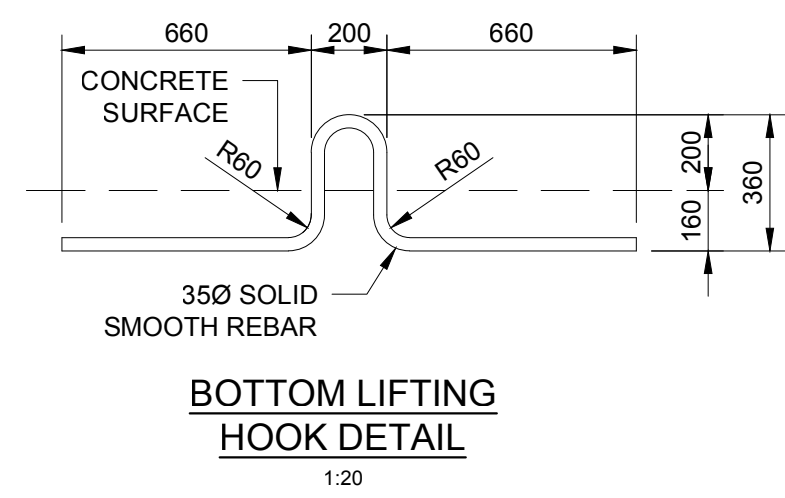
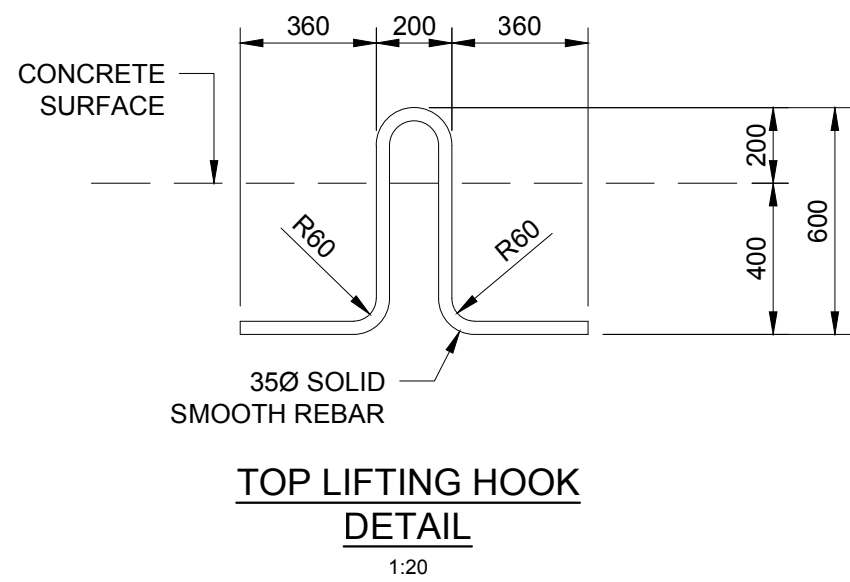
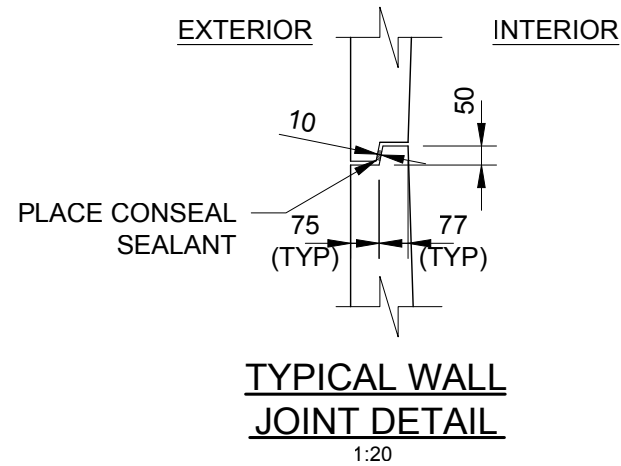

McINTOSH PERRY
115 Walgreen Road, RR3, Carp, ON K0A 1L0
Tel: 613-836-2184 Fax: 613-836-3742
www.mcintoshperry.com



POWER PRECAST SOLUTIONS
5598 POWER ROAD
OTTAWA, ONTARIO
TEL: 613-822-1488

Version	Description	YYYY-MM-DD
2	REVISED FOR 15KPA LIVE LOAD	2022-07-08
1	ISSUED FOR REVIEW	2018-08-31

Stamp

McIntosh Perry

WELLINGS OF STITTSVILLE

PPS JOB NO.: 2018-0803
MH JOB NO.: 2170737.34

DETAILS		
Scale AS NOTED		
DWG No. S-5	Version 1	Date 2018-08-28