

## Engineering

Land/Site  
Development

Municipal  
Infrastructure

Environmental/  
Water Resources

Traffic/  
Transportation

Recreational

## Planning

Land/Site  
Development

Planning Application  
Management

Municipal Planning

Urban Design

Expert      Witness  
(LPAT)

Wireless Industry

## Landscape Architecture

Streetscapes & Public  
Amenities

Open Space, Parks &  
Recreation

Community      &  
Residential

Commercial      &  
Institutional

Environmental  
Restoration



# Hard Rock Ottawa 4837 Albion Road

## Servicing and Stormwater Management Report

**HARD ROCK OTTAWA**

**4837 ALBION ROAD  
OTTAWA, ONTARIO**

**SERVICING AND STORMWATER MANAGEMENT REPORT**

Prepared By:

**NOVATECH**

Suite 200, 240 Michael Cowpland Drive  
Ottawa, Ontario  
K2M 1P6

November 20, 2019

April 24, 2020

Revised: November 7, 2022

Novatech File: 116111  
Report Ref: R-2019-196

November 7, 2022

City of Ottawa  
Planning Infrastructure and Economic Development Department  
110 Laurier Avenue West, 4th Floor  
Ottawa, ON  
K1P 1J1

**Attention: Allison Hamlin, MCIP, RPP, Planner II**

**Reference: 4837 Albion Road Hard Rock Ottawa  
Servicing and Stormwater Management Report  
Novatech File No.: 116111**

---

Novatech has prepared this Servicing and Stormwater Management Report, on behalf of Hard Rock Ottawa, in support of Site Plan and Re-Zoning Applications for review and approval.

The report addresses how the proposed development will be serviced by watermain, sanitary sewer, storm sewers, and stormwater management.

Should you have any questions or comments, please do not hesitate to contact us.

Sincerely,

**NOVATECH**



Cara Ruddle, P.Eng.  
Senior Project Manager | Land Development Engineering

## TABLE OF CONTENTS

<b>1.0</b>	<b>INTRODUCTION.....</b>	<b>1</b>
1.1	Background .....	1
1.2	Proposed Development .....	1
1.3	Site Constraints .....	2
1.4	Background Reports .....	2
<b>2.0</b>	<b>WATER SERVICING.....</b>	<b>2</b>
2.1	Existing Water Services .....	2
2.2	Proposed Water Servicing .....	3
2.2.1	<i>Domestic Water Demands</i> .....	3
2.2.2	<i>Fire Flow</i> .....	3
2.2.3	<i>Hydraulic Analysis</i> .....	4
<b>3.0</b>	<b>SANITARY SERVICING.....</b>	<b>4</b>
3.1	Existing Sanitary Services .....	4
3.2	Proposed Sanitary Services.....	5
3.2.1	<i>Sanitary Flows</i> .....	5
3.3	Existing Sanitary Sewers and Pump Station .....	6
<b>4.0</b>	<b>STORM SERVICING AND STORMWATER MANAGEMENT .....</b>	<b>7</b>
4.1	Previous Studies.....	7
4.1.1	<i>Leitrim Wetlands</i> .....	7
4.1.2	<i>Rideau Carleton Raceway Expansion (OLG Slots)</i> .....	7
4.2	Storm Servicing & Stormwater Management Design .....	7
4.2.1	<i>Minor System (Storm Sewer) Design Criteria</i> .....	8
4.2.2	<i>Major System (Overland Flow) Design Criteria</i> .....	8
4.2.3	<i>Stormwater Quantity Control</i> .....	9
4.2.4	<i>Water Quality Treatment Criteria</i> .....	9
4.2.5	<i>Best Management Practices and Low Impact Development</i> .....	9
4.3	Proposed Storm Infrastructure.....	9
4.3.1	<i>Underground Storage / Infiltration Chambers</i> .....	9
4.3.2	<i>Surface Storage</i> .....	10
4.3.3	<i>Infiltration / Storage Ditch</i> .....	10
4.4	Stormwater Quality Control.....	11
4.4.1	<i>Underground Storage (Infiltration)</i> .....	11
4.4.2	<i>Stormwater Management Pond</i> .....	12
4.5	Stormwater Management Model Development .....	13
4.5.1	<i>PCSWMM Model Parameters</i> .....	13
4.5.2	<i>Building Rooftop Release Rates / Storage</i> .....	15
4.6	PCSWMM Model Results .....	16
4.6.1	<i>Existing Conditions</i> .....	16
4.6.2	<i>Proposed Conditions</i> .....	16
4.6.3	<i>Comparison of Peak Flows and Runoff Volumes</i> .....	17
<b>5.0</b>	<b>EROSION AND SEDIMENT CONTROL .....</b>	<b>18</b>
<b>6.0</b>	<b>CONCLUSIONS AND RECOMMENDATIONS .....</b>	<b>18</b>
<b>7.0</b>	<b>CLOSURE.....</b>	<b>20</b>

## LIST OF TABLES

Table 2.1: Water Demand Summary  
 Table 2.2: Boundary Condition Summary  
 Table 3.1: Sanitary Flow Summary  
 Table 4.1: Water Quality Treatment Volumes (SWM Pond)  
 Table 4.2: Existing Conditions Peak Flows and Runoff Volumes  
 Table 4.3: Proposed Conditions Peak Flows and Runoff Volumes

## LIST OF FIGURES

Figure 1 Key Plan  
 Figure 2 Existing Conditions  
 Figure 3 Proposed Development Plan

## LIST OF APPENDICIES

Appendix A Water Servicing Information  
 Appendix B Sanitary Servicing Information  
 Appendix C Storm Servicing Information  
 Appendix D Stormwater Management Modeling  
 Appendix E Development Servicing Study Checklist  
 Appendix F Drawings

## LIST OF DRAWINGS (enclosed)

Storm Sewer Drainage Area Plan (116111-STM)  
 Stormwater Management Drainage Area Plan (116111-SWM)

## LIST OF DRAWINGS (separate)

Cover Page  
 Notes and Details (116111-ND, ND2)  
 Removals Plan (116111-REM)  
 General Plan of Services (116111-GP, GP1, GP2, GP3, GP4)  
 Grading Plan (116111-GR, GR1, GR2, GR3, GR4)  
 Erosion Sediment Control Plan (116111-ESC)

## ENCLOSED CD

- Report (pdf)
- Drawings (pdf)
- PCSWMM Packaged Model Files
  - 100-year 3-hour Chicago Storm

## 1.0 INTRODUCTION

Novatech has been retained to prepare a Servicing and Stormwater Management Report for the proposed Hard Rock Casino Expansion at 4837 Albion Road within Ottawa, Ontario. This report will support a Site Plan and Re-Zoning Application for the proposed development. **Figure 1** is a Key Plan showing the site location.

This report outlines the site sanitary and water servicing, along with the proposed storm drainage and stormwater management strategy for the proposed development.

### 1.1 Background

The existing Rideau Carleton Raceway and OLG Slots property is located at 4837 Albion Road. The subject property was recently severed into two separate parcels. The Rideau Carleton Raceway has retained the 43.8-hectare undeveloped parcel to the east of the existing racetrack that fronts onto Bank Street. Hard Rock Ottawa presently owns the 40.5-hectare parcel that fronts on to Albion Road. This is the property that is subject to this application.

The 40.5-hectare property at 4837 Albion Road is bound by Albion Road to the West, vacant undeveloped land to the north, the retained Rideau Carleton Raceway property to the east, and farmland to the south. The site slopes away from Albion Road to the low point north of the existing horse barns. **Figure 2** shows the existing site conditions.

Prior to the recent severance the original raceway facility consisted of the raceway building with buffet restaurant, grandstand and racetrack with apron as well as stables, barns and horseman's kitchen located at the rear of the site. The original raceway facility was serviced by a private well and septic system. The existing septic bed continues to service the barn, stables and horseman's kitchen.

In 2000, the existing raceway building was expanded to accommodate the addition of the OLG slots. This expansion included the following works:

- Expansion of the existing watermain system and addition of the fire suppression system.
- Watermain installed across the property to the east connecting to the existing watermain along Bank Street.
- Storm drainage and stormwater management infrastructure.

In 2006, the sanitary sewer system was added with a pump station.

In 2018, a rezoning application was approved by the City of Ottawa for the addition of 20 gaming tables to the existing OLG slots casino and the proposed hotel.

### 1.2 Proposed Development

The proposed Hard Rock Casino expansion will consist of a 6-storey hotel with 150 rooms, multiple different restaurants with a total seat count of 350, a live auditorium with 1800 seats, and an additional 580 gaming positions all under one roof. The proposed expansions will also include expansions and improvements to the existing parking area and laneways. **Figure 3** shows the proposed site development.

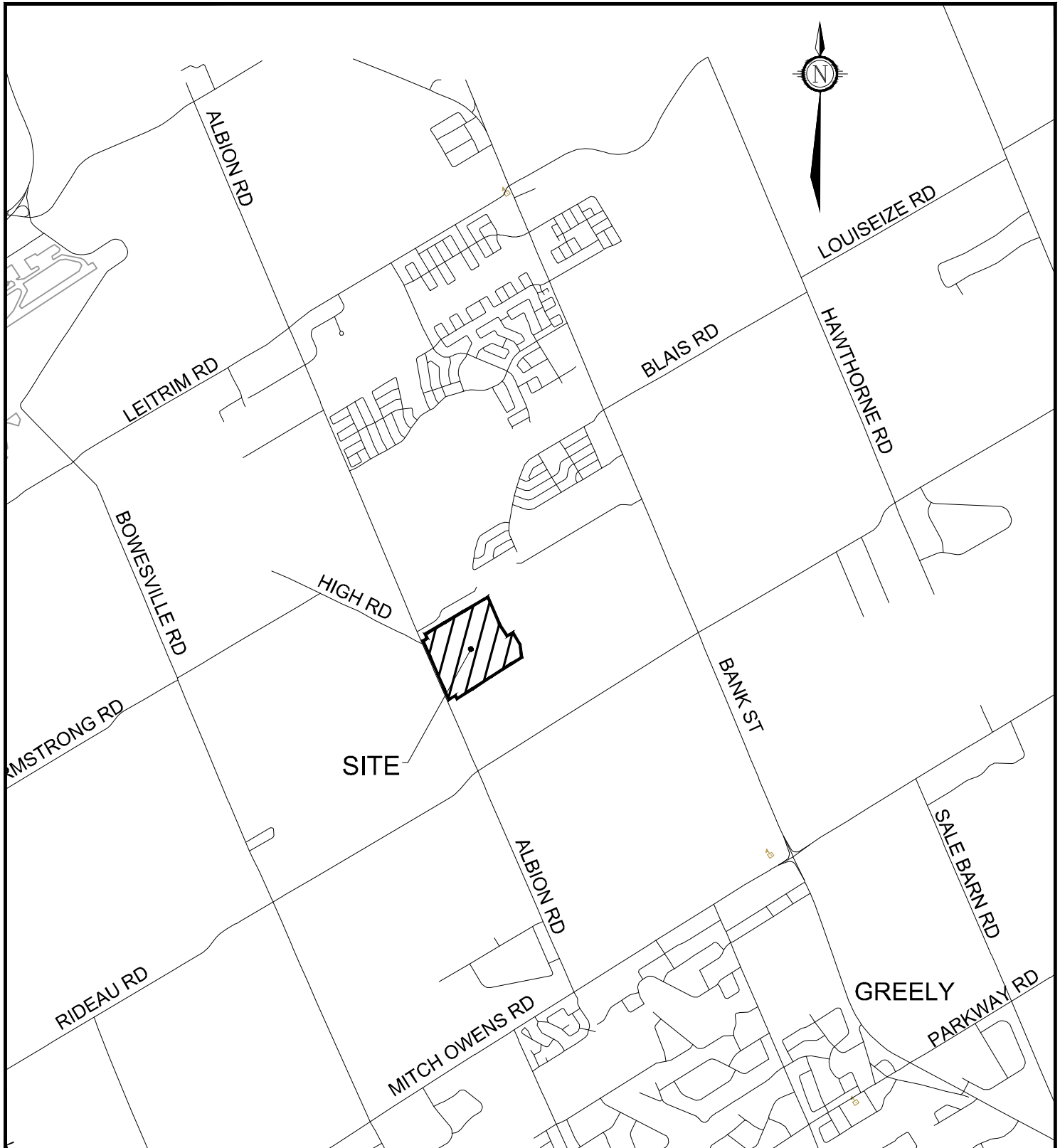

M:\2016\116111\CAD\Design\Report\Figures\116111-KP-FIG1.dwg, FIG 1, Nov 07, 2019 - 3:01pm, arnestwarp



Engineers, Planners & Landscape Architects  
 Suite 200, 240 Michael Cowpland Drive  
 Ottawa, Ontario, Canada K2M 1P6

Telephone (613) 254-9643  
 Facsimile (613) 254-5867  
 Website www.novatech-eng.com

**KEY PLAN**

**CITY OF OTTAWA**

**4837 ALBION ROAD  
 HARD ROCK OTTAWA**

DATE	JOB	FIGURE
NOV 2019	116111	FIG 1

M:\2016\116111\CAD\Design\Report\Figures\116111-EC-FIG2.dwg, FIG 2, Nov 20, 2019 - 12:27pm, mhrehorjak

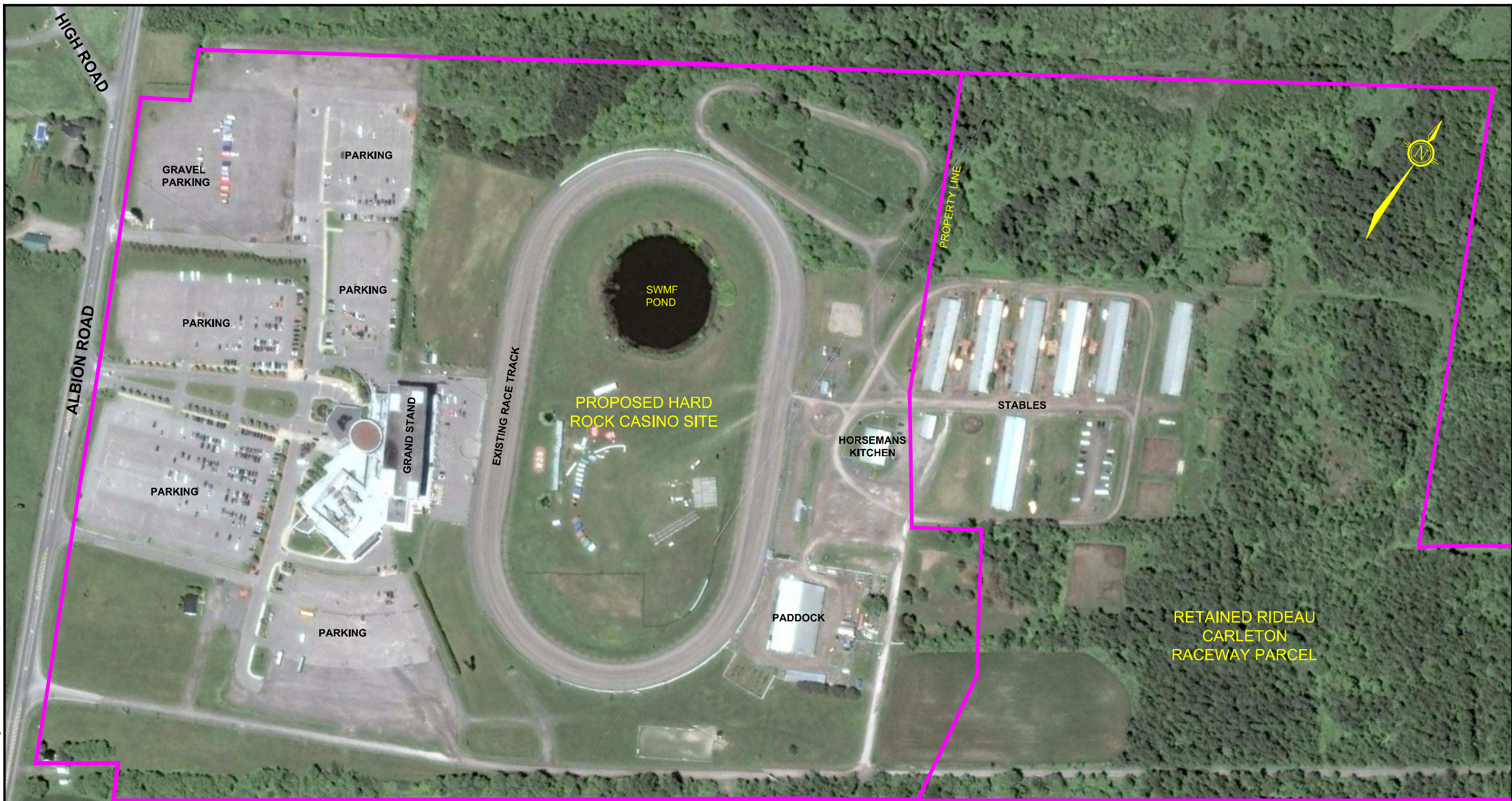

**NOVATECH**

Engineers, Planners & Landscape Architects  
Suite 200, 240 Michael Cowpland Drive  
Ottawa, Ontario, Canada K2M 1P6

Telephone (613) 254-9643  
Facsimile (613) 254-5867  
Website www.novatech-eng.com

4837 ALBION ROAD  
HARD ROCK OTTAWA

**EXISTING CONDITIONS**

SCALE 1 : 3000

DATE APR 2020 JOB 116111 FIGURE FIG 2



M:\2016\116111\CAD\Design\Report\Figures\116111-PS-FIG 3.dwg, FIG3, Oct 26, 2022 - 11:18am, dmaratha

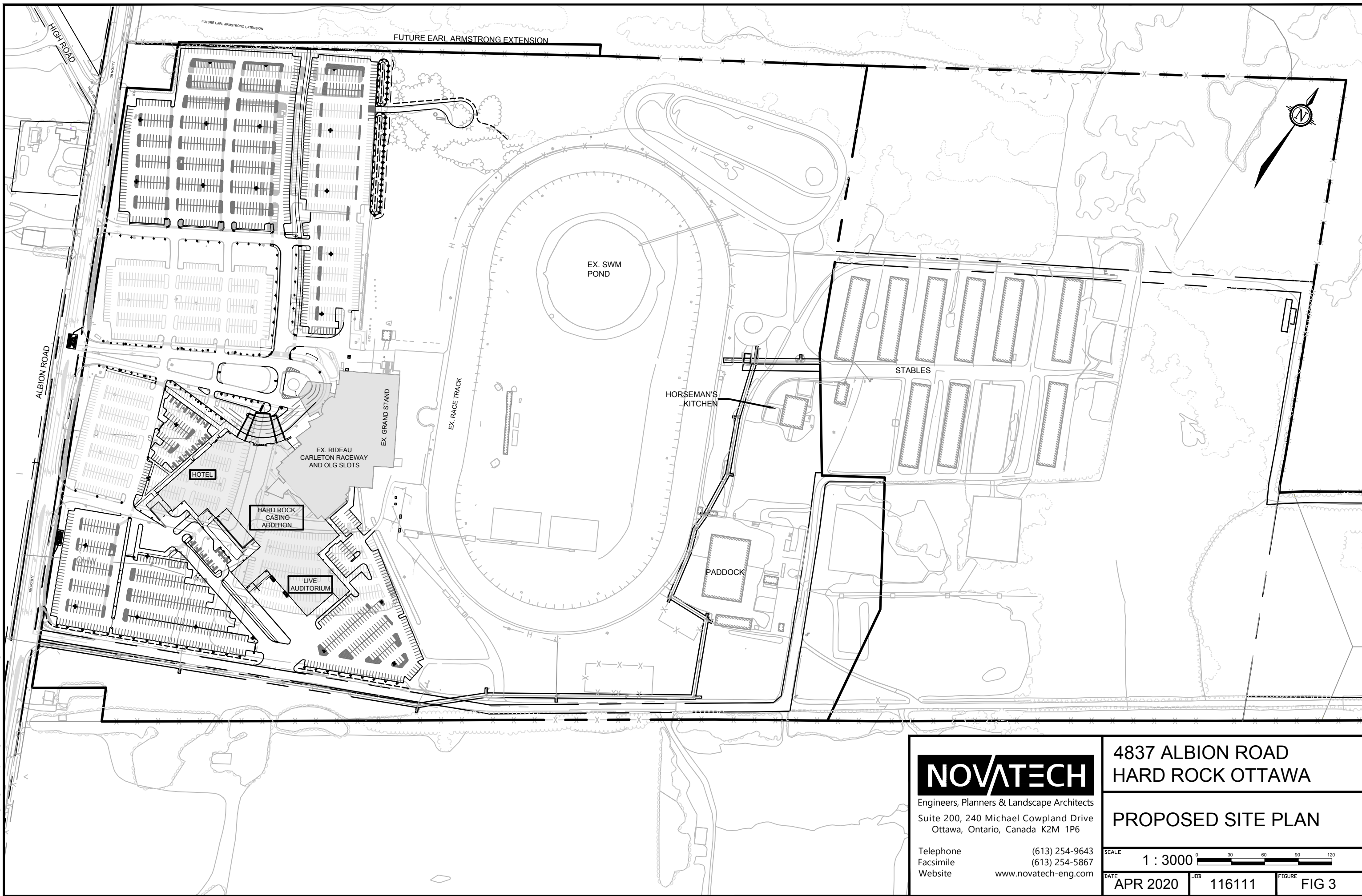

**NOVATECH**

Engineers, Planners & Landscape Architects  
 Suite 200, 240 Michael Cowpland Drive  
 Ottawa, Ontario, Canada K2M 1P6

Telephone (613) 254-9643  
 Facsimile (613) 254-5867  
 Website www.novatech-eng.com

**4837 ALBION ROAD  
 HARD ROCK OTTAWA**

**PROPOSED SITE PLAN**

SCALE 1 : 3000

DATE APR 2020 JOB 116111 FIGURE FIG 3

### 1.3 Site Constraints

Paterson Group performed the geotechnical investigation in support of the proposed development and provided the following report '*Geotechnical Investigation Proposed Building Expansion, 4837 Albion Road, Ottawa, ON Paterson Group*' dated October 30, 2019. The report indicates that bedrock is expected to range from 15m-25m below existing grade and the groundwater table is expected to be at a depth greater than 7m below existing grade. There is a permissible grade raise restriction of 2.0m above existing ground only where a clay deposit is present. An MECP permit to take water is not anticipated during construction; however, if pumping exceeds anticipated rates than a permit to take water application should be filed.

### 1.4 Background Reports

This report provides information on the considerations and approach by which Novatech has designed and evaluated the proposed servicing and stormwater management strategies. This report should be read in conjunction with the following:

- *Geotechnical Investigation, Proposed Building Expansion, 4837 Albion Road, Ottawa, ON Paterson Group (October 30, 2019)*
- *Serviceability Report, 4837 Albion Road, Hard Rock Ottawa, Ottawa, Ontario, Novatech (January 2018)*
- *Sanitary Sewer Brief Rideau Carleton Raceway David McManus Engineering Ltd. (October 6, 2005)*
- *Sanitary Sewage Report Rideau Carleton Raceway David McManus Engineering Ltd. (October 6, 2005)*
- *Rideau Carleton Raceway Expansion Servicing Options Study Oliver, Mangione, McCalla & Associates (March 7, 2000)*
- *Rideau Carleton Raceway Stormwater Design Oliver, Mangione, McCalla & Associates (September 3, 1999)*
- *Leitrim Development Area, Stormwater Management Environmental Study Report and Pre-Design. Golder Associates Limited (August 1994)*
- *Planning for Leitrim and Integrated Approach, Volume II Master Drainage Plan Cumming Cockburn Limited (August 1991)*

## 2.0 WATER SERVICING

### 2.1 Existing Water Services

The existing development is currently serviced from the existing 400mm diameter watermain to the northeast of the site in the Bank Street right-of-way. A 200mm diameter private watermain extends through the property to the east from Bank Street to an existing hydrant by the northwest corner of the property just outside of the Albion Road right-of-way. The existing private 200mm diameter watermain provides a potable water service for the existing Rideau Carleton Raceway Operations, the OLG slots, the horseman's kitchen and paddock at the rear of the racetrack.

### Existing Fire Suppression

There are existing holding tanks and a dry hydrant for fire suppression that service the existing building and sprinkler system.

There is an existing well on the property that provides the following functions:

- Pumps water to the existing fountain in the middle of the racetrack area.
- Pumps water to the existing fire suppression tanks.
- Supplies water (non-domestic) to the existing stables.

## **2.2 Proposed Water Servicing**

The existing 200mm diameter watermain will continue to service the existing development and provide service for the proposed Hard Rock expansion. The existing building water system will be extended internally to the proposed Hard Rock expansion to provide domestic water. Refer to the General Plan of Services (dwg 116111-GP) for watermain servicing details.

### **2.2.1 Domestic Water Demands**

Design Criteria from the City of Ottawa Water Distribution Guidelines and the Ontario Building Code were used to calculate the theoretical water demands for proposed expansion. The demand calculations are based on flow requirements for the proposed different uses on site.

The water demand calculations for the existing facility are based on historical water record data. Detailed water record information and calculations are provided in **Appendix A**. The domestic water demands for the existing and proposed developments are summarized in **Table 2.1** below.

**Table 2.1: Water Demand Summary**

<b>Use</b>	<b>Ave. Daily Demand (L/s)</b>	<b>Max. Daily Demand (L/s)</b>	<b>Peak Hour Demand (L/s)</b>
Existing RCR and OLG Slots	*1.01	1.52	2.74
Proposed Restaurants, Hard Rock Auditorium, Casino Additions	1.34	2.01	3.62
Proposed Hard Rock Hotel	0.70	1.75	3.85
<b>Existing + Proposed Expansion</b>	<b>3.05</b>	<b>5.28</b>	<b>10.21</b>

\*Existing average daily demand calculated from 2015-2017 water meter data.

### **2.2.2 Fire Flow**

Fire flow requirements for the proposed building expansion were calculated by the Mechanical Consultant, SNC Lavalin; refer to Fire Protection Water Supply letter prepared by SNC Lavalin provided in **Appendix A**. This letter indicates that the existing 90,900 gallon (344,100 Litre) and 30,000 gallon (113,560 Litre) underground storage tanks on the north side of the building will be connected to service both the existing and proposed internal building fire suppression systems. The existing 500 USGPM (31.5 LPS) fire pump will be replaced by a new 1250 USGPM (78.9 LPS) pump to meet the fire suppression requirements for all areas of the existing and proposed building. A 70,000-gallon (265,000 Litre) underground storage tank is also proposed in the

southwest parking lot to service a proposed dry hydrant system. The fire department will draw water from the tank and pressurize the dry hydrant system in the event of a fire. Refer to the General Plan of Services (dwg 116111-GP) for details.

**2.2.3 Hydraulic Analysis**

The domestic water demand information was submitted to the City of Ottawa for boundary conditions. The boundary conditions were provided for the existing 400mm watermain on Bank Street. The results of the boundary conditions are summarized below in **Table 2.2**.

**Table 2.2: Boundary Condition Summary**

Condition	Service Connection Location	Demand (L/s)	Min/Max Allowable Operating Pressures (psi)	Limits of Design Operating Pressures (psi)
High Pressure	Bank Street	3.05	80psi (Max)	72.1
Peak Hour	Bank Street	10.21	40psi (Min)	50.9

These boundary conditions were input into the hydraulic model EPANET for analyzing the performance of the existing watermain systems for the following two (2) theoretical conditions:

- 1) High Pressure check under Average Day conditions
- 2) Peak Hour demand

Therefore, based on the proceeding analysis it can be concluded that the watermain, as designed, will provide adequate system pressures for domestic demands. It should be noted that in the future the City has identified potential higher peak demands on the existing Bank Street watermain. These higher demands would result in lower watermain pressures which would be resolved by a second pump at the Leitrim pump station.

Refer to **Appendix A** for detailed model results, schematics of the model and boundary conditions.

**3.0 SANITARY SERVICING**

**3.1 Existing Sanitary Services**

The existing development is currently serviced by an existing 250mm diameter gravity sanitary sewer. The conveyance of sanitary flows is as follows:

- Sanitary flows are conveyed to a private pump station at the north side of the property.
- The existing pump station pumps sanitary flows through a 150mm diameter sanitary forcemain.
- The forcemain outlets to an existing 250mm diameter gravity sanitary sewer within the High Road right-of-way; connecting to an existing 250mm diameter sanitary sewer along Earl Armstrong Road.

- The Earl Armstrong Road sanitary sewer connects to an existing 675mm diameter trunk sanitary sewer approximately 800 meters south west of the Bowesville Road intersection in an unopened road allowance.

A portion of the City of Ottawa Sewer Mapping (geoOttawa) is included in **Appendix B** for reference.

There is an existing septic system east of the existing paddock that services the existing horseman's kitchen, and paddock behind the racetrack. The existing septic system on the inside of the racetrack has been abandoned.

## 3.2 Proposed Sanitary Services

It is proposed to construct a new 250mm diameter sanitary service for the expansion and connect into the existing sanitary sewer by the rear northeast corner of the proposed building expansion. Refer to the General Plan of Services (116111-GP) for details.

### 3.2.1 Sanitary Flows

Flows from the existing development have been calculated using the previously noted historical water usage data. Flows for the proposed development have been calculated using criteria provided in Section 4 of City of Ottawa Sewer Design Guidelines and the Ontario Building Code. Detailed calculations are provided in **Appendix B** for reference.

The sanitary flows are summarized below in **Table 3.1**.

**Table 3.1: Sanitary Flow Summary**

Use	Peak Flow (L/s)	Infiltration Flow (L/s)	Total Peak Design Flow (L/s)
Existing RCR and OLG Slots	*1.52	4.13	5.65
Proposed Restaurants, Hard Rock Auditorium, Casino Additions	2.01	**N/A	2.01
Proposed Hard Rock Hotel	2.24	**N/A	2.24
<b>Existing + Expansion</b>	<b>5.77</b>	<b>4.13</b>	<b>9.90</b>

\*Existing peak flows calculated from 2015-2017 water meter data with a commercial peaking factor applied.

\*\*Infiltration flow accounted for in existing development sanitary flow calculations from the David McManus Engineering Ltd. Sanitary Sewage Report Rideau Carleton Raceway Report, Dated October 6, 2005.

The total theoretical peak sanitary flow for the development including the existing Rideau Carleton Raceway was calculated to be 9.90 L/s. The total sanitary flow is calculated based on a total development area of 14.74ha.

The existing 250mm diameter sewer on site at a minimum slope of 0.28% has a theoretical capacity of 31.4 L/s. The capacity of the existing pump station will be discussed in the following section of the report.

### 3.3 Existing Sanitary Sewers and Pump Station

The existing 250mm diameter gravity sanitary sewer in High Road was originally designed to accommodate the 20-year expansion plan for the Rideau Carleton Raceway. The 20-year plan included a hotel, 1500 seat theater, retail center, trade center and golf course.

The total sanitary peak flow for the 20-year plan was estimated to be 20.64 L/s. This was allocated to the existing pump station and existing sanitary sewer in High Road.

#### Existing Forcemains and Pumps

The forcemain size and pumps were selected such that only minimal changes would be required in the future to allow for increased servicing flows from current conditions to the predicted 20-year flows.

A Flygt Pump model NP-3102-463 was selected and operates under normal conditions at a flow rate of 17.2 L/s.

#### 2005 Sanitary Sewage Report (High Road / Earl Armstrong Road)

The 2005 David McManus Engineering Ltd. Sanitary Sewage Report indicates that the existing 250mm gravity sewer in High Road and Earl Armstrong Road has an excess capacity of 6.01 L/s in the 20-year flow condition plus an allotted 5 L/s from the future Central Canada Exhibition Site located at the northwest corner of the Albion Road and Rideau Road intersection.

As such, there is adequate capacity in the existing sanitary sewer infrastructure for the proposed Hard Rock expansion. Refer to **Appendix B** for the 2005 David McManus Engineering Ltd. report.

#### Assessment on the Existing Pump Station

A Technical Memorandum prepared by Novatech (November 1, 2019) reviews and assesses the condition of the existing pump station. This Technical Memorandum had the following conclusions:

- Operation and Maintenance documentation be compiled for the existing system.
- Improvements for accessing the pump station be completed.
- Enter into a service agreement to provide regular service checks on the pump station and emergency response services.

A copy of the Technical Memorandum is provided in **Appendix B** for reference.

#### CCTV Investigation

A CCTV investigation was completed for the existing gravity sanitary sewer: High Road / Albion Road intersection to approximately 800m south west of the Bowesville Road intersection.

The CCTV Investigation Report prepared by Veolia compiles the CCTV information for the sanitary sewer. The recommendation, from Novatech's review, is to clean the full length of sanitary sewer as there appears to be grease buildup in areas and debris.

A copy of the CCTV Investigation Report, CD of the video footage and Novatech's review is provided in **Appendix B** for reference.

## 4.0 STORM SERVICING AND STORMWATER MANAGEMENT

The Rideau Carleton Raceway was initially built in 1962. The site was previously developed without the incorporation of stormwater management practices. The site was subsequently expanded in 1999 to accommodate the addition of the OLG slots. Storm infrastructure was subsequently installed during the expansion.

### 4.1 Previous Studies

#### 4.1.1 Leitrim Wetlands

The Rideau Carleton Raceway site drains northwards into the Findlay Creek Drain and the Leitrim Wetlands. The Leitrim Wetlands have been classified as a Provincially Significant Wetland.

The Leitrim Wetland was included in the following reports:

- *Planning for Leitrim and Integrated Approach, Volume II Master Drainage Plan*  
*Cumming Cockburn Limited (August 1991)*
- *Leitrim Development Area, Stormwater Management Environmental Study Report and Pre-Design. Golder Associates Limited (August 1994)*

The CCL (1991) report referenced above provided a 5-year flow as 4,515 L/s for a 293 ha area.

#### 4.1.2 Rideau Carleton Raceway Expansion (OLG Slots)

The OLG Slots expansion involved the installation of new storm drainage and stormwater management infrastructure; designed per the following report, provided in **Appendix C**:

- *Rideau Carleton Raceway Stormwater Design*  
*Oliver, Mangione, McCalla & Associates (September 3, 1999)*

The 1999 stormwater design included source controls, private storm sewer system and end-of-pipe stormwater management pond. Inlet control devices were used to restrict peak flows in the storm sewer system. Most catchbasins had offline arch-style infiltration chambers to promote infiltration.

The 1999 stormwater design identified an allowable release rate for the 13.74 ha redevelopment. The allowable release rate was to restrict the 100-year storm event to a 5-year pre-development level (213 L/s). This was the allowable release rate used in the design of the end-of-pipe stormwater management pond.

The stormwater management pond is located within the middle of the racetrack area. The pond outlets via a culvert under the racetrack to a ditch on the north side of the existing horse barns. The remainder of the developed portion of the site east of the racetrack drains by a combination of sheet flows and channelized ditch flow to the same outlet location as the pond outlet ditch.

### 4.2 Storm Servicing & Stormwater Management Design

Storm servicing for the site will be provided using a dual drainage system:

- Runoff will be stored, infiltrated, and conveyed by underground storage / infiltration chambers (minor system).
- Flows from large storm events that exceed the capacity of the minor system will be stored on the surface and conveyed along defined overland flow routes (major system).

Runoff from the site is controlled by the existing stormwater management pond before discharging to the Findlay Creek Drain.

#### **4.2.1 Minor System (Storm Sewer) Design Criteria**

Runoff from frequent events will be conveyed by the existing and proposed storm sewers (minor system). Inlet control devices will be used to restrict flows to the minor system.

##### Storm Sewer Design Criteria

The following is the storm sewer design criteria based on the City of Ottawa Sewer Design Guidelines (October 2012) and associated Technical Bulletins:

- Rational Method ( $Q$ ) =  $2.78CIA$ , where
  - $Q$  = peak flow (L/s)
  - $C$  = runoff coefficient
    - $C = (0.70 * \%Imp.) + 0.20$
  - $I$  = rainfall intensity for a 2-year return period (mm/hr)
    - $I_{2yr} = 732.951 / [(Tc(\text{min}) + 6.199)]^{0.810}$
  - $A$  = site area (ha)
- Minimum Pipe Size = 250 mm; Minimum / Maximum Full Flow Velocity = 0.8 m/s / 3.0 m/s

Refer to the storm sewer design sheets provided in **Appendix C**. It should be noted that most of the sewers in the design sheet are overcapacity. This is due to an existing condition where the existing infrastructure was never adequately sized to convey the uncontrolled 2-year flows. Most of this existing infrastructure including the outlet pipe to the pond is to remain in service under proposed conditions. The undersized existing and proposed infrastructure will be mitigated using inlet controls and underground storage / infiltration, which will be discussed in subsequent sections of the report.

##### Inlet Control Devices

Inlet control devices (ICDs) will be installed in the existing and proposed catchbasins to restrict inflows to the minor system. The ICDs have been sized appropriately to mitigate the undersized overcapacity sewers on site by maximizing the use of underground storage and promoting infiltration. The inlet control design is based on the following criteria:

- |                 |  |
|-----------------|--|
| Existing Areas: | Maximize underground and above-ground storage while preventing surface ponding during the 2-year event.                |
| Proposed Areas: | Maximize flow restrictions to prevent the storm sewer from 'spilling' out of the structure lids in the racetrack area. |

#### **4.2.2 Major System (Overland Flow) Design Criteria**

Flows that exceed the restricted release rates will be stored on the surface. The proposed grading design provides an overland flow path towards the stormwater management pond in the racetrack area and the private laneway to the southeast. Refer to the Grading Plan (Drawing 116111-GR).

##### Major System (Overland Flow) Design Criteria

The following overland flow criteria will be applied to the proposed design for the existing and proposed drainage areas:

- Promote surface storage by ponding stormwater on the surface.



- Ensure no ponding on the surface during a 2-year event.
- Ensure that major system flows have a maximum dynamic depth of 0.35 m during the 100-year event.
- Ensure that water levels will not touch the building envelope / lowest opening during the Stress Test event (100-year +20%).

#### **4.2.3 Stormwater Quantity Control**

There is no defined release rate for minor & major system flows from the parking area / building to the pond within the center of the racetrack. The restricted release rates from the 1999 stormwater management report would result in excessive overland flow to the racetrack / pond.

To minimize the impact on the performance of the existing pond the 100-year is to be contained within the parking area for the proposed areas being retrofitted. The total minor & major system peak flows and runoff volumes from the parking area are to be less than existing conditions; per the existing conditions model.

#### **4.2.4 Water Quality Treatment Criteria**

The proposed development is within the jurisdiction of the Rideau Valley Conservation Authority (RVCA). The water quality treatment criteria for the proposed development is to provide an Enhanced level of water quality treatment. This corresponds to 80% long-term removal of total suspended solids (TSS).

#### **4.2.5 Best Management Practices and Low Impact Development**

The proposed development is to utilize the use of best management practices (BMPs) and low impact development (LID) techniques. This will reduce the impacts of the proposed development on the hydrologic cycle; and mitigate the reduction in groundwater infiltration / recharge resulting from the proposed increase in impervious areas. For further information refer to **Section 4.4.1** of the report.

### **4.3 Proposed Storm Infrastructure**

The existing storm sewer network will need to be modified for the proposed development as a large area of the existing parking lot area will be developed / redeveloped. Refer to the following drawings for the existing / proposed storm servicing design:

116111-GP1 to GP4	General Plan of Services	(provided separately)
116111-GR1 to GR4	Grading Plans	(provided separately)
116111-STM	Storm Sewer Drainage Area Plan	(Appendix C)
116111-SWM	Stormwater Management Plan	(Appendix D)

The existing stormwater management design concept will be continued and incorporated into any modifications to the storm sewer system. This includes surface ponding in parking areas / ditches and rooftops and use of underground storage chambers.

#### **4.3.1 Underground Storage / Infiltration Chambers**

Underground storage will be required for the proposed development to attenuate runoff. By adhering to the 1999 flow restrictions surface ponding would occur during the 2-year storm event.

Underground storage is provided to store runoff from a 2-year storm event and infiltrate stormwater for a 5mm (4-hour Chicago) storm.

The underground storage systems will consist of Stormtech SC-740 arch-type chambers (or approved equivalent), which are covered in 50mm dia. (D50) clearstone. The chambers will be installed under the parking areas immediately upstream each inlet.

A total of 502 proposed Stormtech SC-740 arch-type chambers will provide approximately 1,193 m<sup>3</sup> of underground storage. Storage is provided in the chambers and surrounding clearstone.

Refer to **Appendix C** for further details. The proposed layout of underground storage chambers is shown on the General Plan of Services (drawing 116111-GP).

The underground storage / infiltration chamber system is consistent with the 1999 approach for stormwater management.

#### Isolator Row

Pre-treatment will be provided via the Isolator Row within the underground storage system. The Isolator Row is a row (typically first row) of Stormtech SC-740 arch-type chambers that is designed to treat the “first flush”. The Isolator Row accomplishes this in two ways. The first is by way of settlement. The Isolator Row length is provided to allow for larger particles to settle out as the flows travel down the Isolator Row. In addition to settling, the Isolator Row is surrounded by filter fabric (geotextile) and is not connected directly to the outlet and as such the water must pass through the filter fabric to make its way to the other chambers and ultimately to the outlet.

The “first flush” Stormwater runoff is directed to the Isolator Row via a weir or elevated bypass. This is done to ensure on frequent (small) storm events are directed to the Isolator and not large events with high velocities that can cause resuspension of the sediment. This protects the adjacent chambers & surrounding clearstone from sediment accumulation.

Sediment will accumulate on the filter fabric within the Isolator Row. As such, the Isolator Row will require period maintenance (i.e. jet flushing / vacuuming). Refer to **Appendix C** for further information on the Isolator Row and maintenance procedures.

#### **4.3.2 Surface Storage**

The parking areas have been designed to store runoff from storms that exceed the capacity of the underground storage chambers at each inlet. The site has been graded to ensure that ponding is confined within the parking areas at a maximum depth of 0.35 m (static ponding + dynamic flow).

Overland flow paths have been provided to ensure that runoff from extreme storm events that exceed the available storage can be safely directed towards the stormwater management pond.

#### **4.3.3 Infiltration / Storage Ditch**

The existing ditch at the northeast portion of the site will be expanded to store and infiltrate drainage from the northeast parking lot. The proposed infiltration / storage ditch will provide 395 m<sup>3</sup> of storage and include a 300mm subdrain surrounded by clearstone to promote infiltration. An ICD will be installed within the existing catchbasin to restrict peak flows to the existing storm sewer system. Refer to Section A-A on the Notes and Detail (drawing 116111-ND).

## 4.4 Stormwater Quality Control

Stormwater quality control will be provided via the underground storage / infiltration chambers and the end-of-pipe stormwater management pond. An oil and grit separator unit (OGS) is proposed in the loading dock/ garbage compactor area to treat any potential spills and contaminants. Refer to **Appendix C** for additional details on the OGS unit.

### 4.4.1 Underground Storage (Infiltration)

Water quality treatment will initially be provided by the underground storage / infiltration chambers (source controls). Ultimately water quality treatment is provided by the water quality pond in the center of the racetrack.

The underground storage chambers have been designed per the following design guidance provided in the MOE Stormwater Management Planning (SWMP) and Design Manual (March 2003), for a pervious pipe / infiltration system for stormwater management:

- 1 Provide storage volume per the water quality storage requirements provided in Table 3.2 (MOE, 2003).
- 2 Provide storage volumes for the pervious pipe / infiltration system equal to the runoff from a 5mm – 4-hour storm (minimum) and 15mm – 4-hour storm (maximum).
- 3 Native soils should have a percolation rate greater than 15 mm/hr.
- 4 The bottom of the storage layer should be located at least 1m above the depth of bedrock and seasonally high groundwater table.

#### Percolation Rates

Estimated percolation rates were provided based on the permeameter testing documented in the following memorandum (provided in **Appendix C**):

Permeameter Test Investigation – Proposed Infiltration System  
Hard Rock Ottawa – 4837 Albion Road, Ottawa  
Paterson Group (November 26, 2019)

The estimated percolation rates ranged from 25 mm/hr to 110 mm/hr. For design purposes the estimated percolation rates were divided by 2 to account for clogging; per the Low Impact Development Stormwater Management Planning and Design Guide (CVC/TRCA, 2010).

Estimated percolation rates for each catchbasin are provided in **Appendix D**.

#### Existing Infiltration

Under existing conditions quality control of stormwater is provided using a combination of source and conveyance controls. Source controls are provided in the form of dry wells (infiltration chambers) installed at each catchbasin.

The provided storage for infiltration is 6.7 m<sup>3</sup> per inlet via 10x arch-type infiltration chambers. This value was based the total area to the existing catchbasins (6.47 ha) multiplied by the runoff coefficient and 5mm. The total storage volume of 226 m<sup>3</sup> was divided by the number of catchbasins (34) that are connected to a dry well.

#### Proposed Infiltration

The clearstone base of the underground storage chambers will provide storage for infiltration. Additional infiltration will also be provided due to the restrictiveness of the ICDs and high percolation rate of the surficial sandy soils.

Overall the site will store and infiltrate (at a minimum) 7.5mm of runoff (224 m<sup>3</sup>). Refer to **Appendix D** for a summary of the infiltration storage volumes.

#### Depth of Bedrock / Groundwater

The geotechnical investigation (Paterson Group, October 30, 2019) indicates that bedrock was observed at an elevation of 93.90 m at BH4-19. In addition, the report states that groundwater was observed at BH4-19 (99.34 m) & BH7-19 (103.87 m).

The lowest elevation for the proposed infiltration chambers (clearstone) is 110.90 m; therefore, the infiltration-based measures meet the minimum requirements for depth to bedrock / groundwater (min. 1.0 m); as outlined in the Low Impact Development Stormwater Management Planning and Design Guide (CVC/TRCA, 2010).

#### **4.4.2 Stormwater Management Pond**

The stormwater management pond in the middle of the racetrack area was sized to provide water quality treatment for a 12.88 ha area with an assumed 85% imperviousness. Runoff from the building rooftop was not included in the calculations as rooftop runoff does not require water quality treatment.

The pond is considered a 'wet pond' with a permanent pool and extended detention. The 1999 stormwater design provided required storage volumes based on the MOE Stormwater Management Practices, Planning and Design Manual (June 1994), which was superseded in by the SWMP and Design Manual (March 2003).

**Table 4.1** provides a comparison of the provided and required permanent pool and extended detention volumes. The 2020 design required storage volumes are based on Table 3.2 in the SWMP and Design Manual (March 2003). Based on 85% impervious the required water quality treatment volume for a wet pond is 250 m<sup>3</sup>/ha; of which 210 m<sup>3</sup>/ha is the permanent pool and 40 m<sup>3</sup>/ha is the extended detention.

**Table 4.1: Water Quality Treatment Volumes (SWM Pond)**

Pond Feature	Provided Storage Volume	Required Storage Volume	
		1999 Design	2022 Design*
Permanent Pool	5,179 m <sup>3</sup>	2,705 m <sup>3</sup> (210 m <sup>3</sup> /ha x 12.88 ha)	2,434 m <sup>3</sup> (203 m <sup>3</sup> /ha x 11.97 ha)
Extended Detention	2,350 m <sup>3</sup>	515 m <sup>3</sup> (40 m <sup>3</sup> /ha x 12.88 ha)	479 m <sup>3</sup> (40 m <sup>3</sup> /ha x 11.97 ha)
<b>TOTAL</b>	<b>7,529 m<sup>3</sup></b>	<b>3,220 m<sup>3</sup></b>	<b>2,913 m<sup>3</sup></b>

\*Permanent pool volume based on interpolating values presented in Table 3.2 of the SWM Planning & Design Manual. (MOE, 2003)

The 1999 stormwater management report assumed a 12.88 ha area based on 85% imperviousness. The proposed development will have less treatable area (11.97 ha) due to the additional building. The overall imperviousness is slightly less (81%) than previously assumed. The required permanent pool volume is less than what was previously estimated; therefore, no modifications are proposed for the stormwater management pond. However, as part of the development it is proposed to perform regular maintenance on the pond by draining and removing any sediment buildup.

## 4.5 Stormwater Management Model Development

Dual drainage stormwater management models (PCSWMM) for existing conditions and proposed conditions were prepared. The models provide estimated minor and major system peak flows, overland flow depths, HGL elevations, and on-site storage requirements.

### 4.5.1 PCSWMM Model Parameters

#### Design Storms

The model includes the following design storms based on the City of Ottawa IDF data presented in the City of Ottawa Sewer Design Guidelines (October 2012):

- 3-hour Chicago Storm Distribution (10-minute time step)
- 12-hour SCS Storm Distribution (30-minute time step)

Each storm distribution includes the 2-year, 5-year, 100-year, and 100-year (+20%) return periods. The 100-year (+20%) return period is used to 'stress test' the storm drainage system. It has a 20% higher intensity and total volume compared to the 100-year event. The 'stress test' event would be comparable to a 500-year to 800-year storm event.

The 3-hour Chicago distribution generates the highest peak flows for both the minor and major systems and was determined to be the critical storm distribution for the design and analysis of the storm drainage system.

#### Historical Storms

The historical storm events in the City of Ottawa are as follows:

- July 1, 1979
- August 4, 1988
- August 8, 1996

When compared to design storms the historical storms produce higher runoff volumes or peak flows. As such, they are compared to the 100-year (+20%) stress-test event.

The historical storm events are used to assess how the storm drainage and stormwater management system will function under extreme events. The results from the historical storms are to be used to identify if there would be severe flooding to properties. It is also used to check if the drainage system needs to be modified.

A summary of the historical and design storm distributions is provided in **Appendix D**.

#### PCSWMM Model Schematics, Output Data and Modeling Files

PCSWMM model schematics and output data for the 100-year 3-hour Chicago storm distribution is provided in **Appendix D**. The PCSWMM modeling files are provided on the enclosed CD.

#### Subcatchment Areas

For modeling purposes, the site has been divided into subcatchments based on the drainage areas tributary to each inlet of the existing and proposed storm sewer systems. The subcatchment areas are shown on the Stormwater Management Area Plan (drawing 116111-SWM).

The hydrologic modeling parameters for each subcatchment were developed based on the Site Plan (Figure 3) and the Stormwater Management Plan specified above. Subcatchment parameters are provided in **Appendix D**.

Impervious Values

Runoff coefficients for each subcatchment area were determined based on the proposed site plan. Refer to the Stormwater Management Plan (drawing 116111-SWM) for details. Percent impervious values were calculated using the following formula:

$$\%imp = \frac{c - 0.2}{0.7}$$

Infiltration

Infiltration losses for all catchment areas were modeled using Horton's infiltration equation, which defines the infiltration capacity of soil over the duration of a precipitation event using a decay function that ranges from an initial maximum infiltration rate to a minimum rate as the storm progresses. The default values as specified in the Sewer Design Guidelines were used for all catchments.

Horton's Equation:  
 $f(t) = f_c + (f_o - f_c)e^{-k(t)}$

Initial infiltration rate:  $f_o = 76.2$  mm/hr  
 Final infiltration rate:  $f_c = 13.2$  mm/hr  
 Decay Coefficient:  $k = 4.14$ /hr

Depression Storage

The default values for depression storage (1.57mm impervious / 4.67 mm pervious) have been applied to all catchments.

The 'zero impervious' parameter (areas with no depression storage) represents the percent of roof top areas to total impervious area. The 'zero impervious' parameter for the existing and proposed building rooftops is set to 100%.

Subarea Routing

Subarea routing for all subcatchments is set to 'direct to outlet'.

Equivalent Width

The 'Equivalent Width' parameter refers to the width of the subcatchment flow path.

The equivalent width parameter for all subcatchments is based on the measured flow length. Flow lengths were digitized in PCSWMM as described in Section 5.4.5.6 of the City of Ottawa Sewer Design Guidelines (October 2012).

The flow paths are shown on the PCSWMM model schematics provided in **Appendix D**.

Inlet Control Devices

In the existing conditions PCSWMM model ICDs were sized to provide a 100-year peak flow that is equivalent to the restricted flow rate specified in the 1999 storm sewer design sheet.

Proposed inlet control devices (ICDs) are represented in the model as theoretical circular orifices. The proposed ICDs will consist of IPEX Tempest LMF (vortex type) or HF (snout type) ICDs (or approved equivalent). ICD information is indicated on the General Plan of Services (drawing 116111-GP). Refer to ICD information provided in **Appendix D**. Documentation for the Tempest LMF & HF ICD's is provided in **Appendix C**.

Storage Rating Curves

The stage-storage curves for each inlet were calculated based on the number of proposed Stormtech SC-740 storage chambers provided (at a depth of 0.76 m) and based on the maximum amount of surface storage. Surface storage volumes were estimated based on the proposed

Grading Plan (drawing 116111-GR) and existing 1:1000 topographic mapping provided by the City of Ottawa.

The total underground and surface storage for each inlet is provided in **Appendix D**.

Minor System Conduits (Bend / Exit Losses)

The minor system network was created in Civil3D and imported into PCSWMM. The following exit losses have been inputted into the model. They represent the loss coefficient based on the bend angle, as per the Appendix 6-B in the City of Ottawa Sewer Design Guidelines (October 2012).

<u>Bend Angle</u>	<u>Loss Coefficient</u>
0	0.00
15	0.09
30	0.21
45	0.39
60	0.64
75	0.96
90	1.32

Major System Conduits

Major system conduits (overland flow network) have been defined using rectangular transect with a 3m length, 3m bottom width, and 1m theoretical depth. These values have been chosen to reduce the amount of surface storage accounted for while maintaining model stability. Short conduit lengths lead to model stability issues.

Junctions representing high points have an invert elevation that represents the lowest 'spill' elevation, depending on the path of the overland flow route.

Downstream Boundary Conditions (Outfalls)

The storm sewer outlet for the proposed development is the existing stormwater management pond. The pond storage volumes and outlet control structures are not included in the model. The model was run using a 'Normal' outfall for the minor system and 'Free' outfall for the major system.

**4.5.2 Building Rooftop Release Rates / Storage**

The building rooftops were simulated in PCSWMM based on an outlet rating curve and using a storage node to represent the available storage provided by the roof surface. For modeling purposes, the available storage and flow rating curve for the roof drains has been multiplied by the number of drains on each roof, and the total rooftop storage lumped into a single storage node.

The outlet rating curve for the proposed building rooftop includes the following overall peak flows for the 5-year and 100-year storm events:

<u>Rooftop Release Rates</u>	<u>5-year</u>	<u>100-year</u>	<u>Storage Provided</u>
North Outlet (R1-R8, R10)	45.3 L/s	77.6 L/s	449.5 m <sup>3</sup>
East Outlet (R9, R11-R14)	22.1 L/s	37.9 L/s	150.7 m <sup>3</sup>
<b>TOTAL</b>	<b>67.4 L/s</b>	<b>115.5 L/s</b>	<b>600.2 m<sup>3</sup></b>

The existing building had an assumed release rate of 196.8 L/s, per the 1999 storm sewer design sheet. To adhere to this flow rate, the model has an assumed rooftop storage area in the existing rating curve that represents 50% of the existing roof area.

Refer to Roof Drain calculations provided in **Appendix C**.

## 4.6 PCSWMM Model Results

### 4.6.1 Existing Conditions

An existing conditions PCSWMM model was developed to determine the minor and major system peak flows and volumes of runoff to the existing SWM pond. The drainage areas and flow restrictions are based on those specified in the 1999 storm sewer design sheet, which identified flow restrictions for each storm sewer run. The total restricted minor system peak flow to the stormwater management pond is 591.0 L/s. Refer to reproduced existing conditions (1999) storm sewer design sheet provided in **Appendix C**.

Major system ponding areas and spill elevations are based on an existing topographic surface developed from the City of Ottawa's 1:1000 mapping product. The results of the existing conditions model are provided in **Table 4.2**.

**Table 4.2: Existing Conditions Peak Flows and Runoff Volumes**

Scenario	Peak Flow (L/s)			Total Runoff Volume (m <sup>3</sup> )
	Minor System	Major System	TOTAL	
2-year	472	339	811	3,334
5-year	514	675	1,189	4,582
100-year	591	3,599	4,190	8,315
100-year (+20%)	601	4,291	4,892	10,217

*\*PCSWMM model results for the 3-hour Chicago storm distribution.*

Our existing conditions model indicates there is considerable overland flow to the pond. This overland flow would predominantly flow down the laneways / pathways towards the racetrack / grandstand. The model indicates that overland flow would be observed during more frequent (i.e. 5-year) storm events.

It is recommended that major system flows be stored within the parking area for all storms up-to and including the 100-year storm event. This approach will utilize the available storage within the parking area and reduce overall (minor & major system) peak flows and runoff volumes to the pond.

### 4.6.2 Proposed Conditions

#### Hydraulic Grade Line

The results of the analysis were used to determine if there would be any surcharging from the storm sewer system during the 100-year storm event. **Appendix D** provides a summary of the 100-year HGL elevation at each storm manhole, as well as a summary of the HGL elevations for a 20% increase (rainfall intensity and total precipitation) in the 100-year design event.

The results of the HGL analysis and the stress testing indicates that the proposed storm sewer will surcharge during the 100-year event and 100-year (+20%) storm event; however, the HGL will not spill out of the structures in the racetrack area.



### Major System Design and Analysis

The major system network was evaluated using the PCSWMM model to ensure that the ponding depths conform to City of Ottawa standards. A summary of ponding depths at each inlet for the 2-year, 5-year, 100-year and 100-year (+20%) events are provided in **Appendix D**.

There is no ponding during the 2-year storm event for the existing and proposed inlets. In addition, the maximum static and dynamic ponding depths are less than 0.35m during the 100-year storm event, thereby meeting the major system criteria for the existing and proposed areas.

### Historical Storms

As per technical bulletin PIEDTB-2016-01: “the depth of flow may extend adjacent to the right-of-way provided that the water level must not touch any part of the building envelope and must remain below the lowest building opening during the ‘stress-test’ event”.

The lowest building opening (i.e. finished floor elevation) for the existing and proposed buildings is 114.00 m. The catchbasins adjacent the buildings were used to compare the computed max hydraulic grade line (HGL) elevations for the historical storms and ‘stress-test’ events. Refer to results provided in **Appendix D**.

The maximum computed HGL elevation near the buildings was 113.74 m. Therefore, during the ‘stress test’ and historical storm events a minimum of 0.26 m of freeboard is provided to the lowest building opening (finished floor elevation).

### **4.6.3 Comparison of Peak Flows and Runoff Volumes**

**Table 4.3** provides a summary of the proposed minor system & major system peak flows and runoff volumes. These values are to be compared with the results from the existing conditions model (**Table 4.2**).

**Table 4.3: Proposed Conditions Peak Flows and Runoff Volumes**

Scenario	Peak Flow (L/s)			Total Runoff Volume (m <sup>3</sup> )
	Minor System	Major System	TOTAL	
2-year	728	0	728	3,147
5-year	923	0	923	4,463
100-year	1,140	0	1,140	8,188
100-year (+20%)	1,197	656	1,853	10,576

*\*PCSWMM model results for the 3-hour Chicago storm distribution.*

The 100-year minor system peak flow to the pond is higher than the restricted release rates provided in the 1999 storm sewer design sheet. The total 100-year major system peak flows will be contained within the parking area for all storms up-to and including the 100-year storm event. As such, the total minor and major system peak flow to the pond is less than those estimated in the existing conditions model.

Runoff volumes are less than those estimated with the existing conditions model for all storms up-to and including the 100-year event. As such, the proposed storm drainage and stormwater management design should have no impact on the pond and pond release rates.

The PCSWMM model is based on the existing and proposed storm drainage and grading design. By adhering to the allowable release rates specified in the 1999 storm sewer design sheet the site is overcontrolling the minor system, which results in additional major system flow.

## 5.0 EROSION AND SEDIMENT CONTROL

Temporary erosion and sediment control measures will be implemented on-site during construction in accordance with the Best Management Practices for Erosion and Sediment Control. This includes the following temporary measures:

- Filter socks (catchbasin inserts) will be placed in existing catchbasins and manholes, and will remain in place until vegetation has been established and construction is completed;
- Silt fencing will be placed along the surrounding construction limits;
- Mud mats will be installed at the site entrances;
- The contractor will be required to perform regular street sweeping and cleaning as required, to suppress dust and to provide safe and clean roadways adjacent to the construction site;

Erosion and sediment control measures should be inspected daily and after every rain event to determine maintenance, repair or replacement requirements. Sediments or granulars that enter site sewers shall be removed immediately by the contractor. These measures will be implemented prior to the commencement of construction and maintained in good order until vegetation has been established. Refer to the Erosion and Sediment Control Plan (117203-ESC) for additional information.

## 6.0 CONCLUSIONS AND RECOMMENDATIONS

### Watermain

The analysis of the proposed watermain network confirms the following:

- The existing 200mm diameter watermain that connects to the existing watermain along Bank Street has adequate capacity to service the proposed development.
- The proposed expansion will be services via extension of internal plumbing.
- The existing fire suppression storage tanks will be connected to service the sprinkler system. An additional 70,000-gallon (265,000-Litre) fire suppression storage tank is proposed to service a proposed dry hydrant system on site.

### Sanitary Servicing

The analysis of the proposed sanitary servicing confirms the following:

- There is adequate capacity within the existing sanitary servicing infrastructure including the existing sanitary sewer, forcemain and pump station, to service the proposed development.
- Connection to existing sanitary sewer will include a minor extension to the existing gravity system.

### Stormwater Management

The following provides a summary of the storm sewer and stormwater management system:

- No modifications are proposed for the stormwater management pond or pond outlet structure with exception of removing the sediment from the bottom of the pond.
- Proposed storm sewer system will connect with the existing storm sewer system.
  - Storm sewers (minor system) are limited by the downstream sewer size. Inflows to the minor system will be controlled using inlet control devices (ICDs).
  - The existing storm servicing infrastructure can be modified to service the proposed development.
  - The 100-year hydraulic grade line (HGL) will not spill out of the structures within the racetrack area.
- Parking lot graded to maximize surface stormwater storage during storm events that exceed the allowable minor system inlet rate.
  - The major overland flow outlet from the parking area to the existing stormwater management pond.
  - No ponding of stormwater during a 2-year storm event and ponding depths will not exceed 0.35m for all storms up to and including the 100-year event.
- Underground storage will be provided to prevent surface ponding during a 2-year storm and promote infiltration.
  - The underground storage / infiltration system will consist of Stormtech SC-740 arch-type chambers (or approved equivalent).

### Erosion and Sediment control

- Erosion and sediment control measures (i.e. filter fabric, catchbasin inserts, silt fences, etc.) will be implemented prior to construction and are to remain in place until vegetation is established.

## 7.0 CLOSURE

The preceding report is respectfully submitted for review and approval. Please contact the undersigned should you have questions or require additional information.

### NOVATECH

Prepared by:



Matt Hrehoriak, P.Eng.  
Project Manager  
Land Development Engineering

Conrad Stang, M.A.Sc., P.Eng.  
Project Manager  
Water Resources

Reviewed by:

A handwritten signature in blue ink, appearing to read "Cara Ruddle".

Cara Ruddle, P.Eng.  
Senior Project Manager  
Land Development Engineering

A handwritten signature in black ink, appearing to read "J. Lee Sheets".

J. Lee Sheets, C.E.T.  
Director  
Land Development Engineering

**Appendix A**  
Water Servicing Information

**Table 1.0: 4837 Albion Road City of Ottawa Water Meter Usage**

Year	Month	Usage (m3)
2015	September	2,842
	October	2,364
	November	1,945
	December	1,694
2016	January	1,421
	February	1,284
	March	1,574
	April	1,539
	May	1,399
	June	2,133
	July	1,852
	August	2,468
	September	1,809
	October	1,694
	November	1,829
	December	1,508
2017	January	1,595
	February	1,728
	March	1,948
	April	2,228
	May	1,861
	June	1,980
	July	2,006
	August	2,582

**Table 1.1 Existing Development Water Demand Calculations from Metered Usage**

Condition	Total Usage (m <sup>3</sup> )	No. of Months	Monthly Flow (m <sup>3</sup> /month)	Daily Flow (m <sup>3</sup> /day)	Avg Day Demand (L/s)	Max Day Demand (L/s)	Peak Hour Demand (L/s)
Average Months	45283	24	1887	63	0.73	1.09	1.97
Min Month	1284	1	1284	43	0.50	0.74	1.34
Max Month	2842	1	2842	95	1.10	1.64	2.96
Annual Max Month Avg	7892	3	2631	88	1.01	1.52	2.74

**Design Parameters:**

Commercial Peaking Factor (Section 4.0 Ottawa Water Distribution Guidelines)

Max. Daily Demand:

1.5 x Avg. Day

Peak Hourly Demand:

1.8 x Max. Day

**Table 2.0: OLG Slots Water Meter Usage**

Year	Month	Usage (m3)
2015	January	1,083
	February	1,009
	March	1,253
	April	1,235
	May	1,463
	June	1,270
	July	1,325
	August	1,328
	September	1,196
	October	1,177
	November	1,147
	December	881
2016	January	699
	February	709
	March	859
	April	872
	May	814
	June	1,091
	July	1,105
	August	1,139
	September	959
	October	984
	November	869
	December	807
2017	January	902
	February	988
	March	1,024
	April	1,011
	May	1,073
	June	1,101
	July	1,157
	August	1,175
	September	1,060
	October	1,040

**Table 2.1 Existing OLG Slots Water Demand Calculation from Metered Usage**

Condition	Total Usage (m <sup>3</sup> )	No. of Months	Monthly Flow (m <sup>3</sup> /month)	Daily Flow (m <sup>3</sup> /day)	Avg Day Demand (L/s)	Max Day Demand (L/s)	Peak Hour Demand (L/s)	No. Existing Slots	OLG Slot Demand (L/Slot/day)
Average Months	35805	34	1053	35	0.41	0.61	1.10	1250	28
Min Month	699	1	699	23	0.27	0.40	0.73	1250	19
Max Month	1463	1	1463	49	0.56	0.85	1.52	1250	39
Annual Max Month Avg	3642	3	1214	40	0.47	0.70	1.26	1250	32

**Design Parameters:**

Commercial Peaking Factor (Section 4.0 Ottawa Water Distribution Guidelines)

Max. Daily Demand:

1.5 x Avg. Day

Peak Hourly Demand:

1.8 x Max. Day

**Table 3.0: Water Demands Existing Building**

Node	Commercial Demand (L/s)		
	* Avg Day	Max. Daily	Peak Hour
Existing Building	1.01	1.52	2.74

\*Note: Average Day demand calculated from averaged peak month demand from City of Ottawa metered water usage from 2015-2017

**Table 3.1: Water Demands Phase 2 Hard Rock Entertainment**

Node	Commercial Yield Amenity / Attraction				Commercial Demand (L/s)		
	*Gaming Positions (No. Positions)	Restaurant Seats (No. Seats)	Hard Rock Live Auditorium (No. Seats)	New Employees (No. Employees)	Avg Day	Max. Daily	Peak Hour
Hard Rock Casino	580	350	1800	230	1.34	2.01	3.62

\*Note: Includes the 35 gaming tables from the phase1 additions.

**Table 3.2: Water Demands Phase 2 Hard Rock Hotel**

Node	Hotel Yield		Residential Demand (L/s)		
	Units	Total Population	Avg Day	Max. Daily	Peak Hour
Hard Rock Hotel	150	270	0.70	1.75	3.85

**Table 3.3: Water Demands Total Proposed and Existing Development**

Node	Total Demand (L/s)		
	Avg Day	Max. Daily	Peak Hour
Existing + Hard Rock Addition	3.05	5.28	10.21

**Design Parameters:**

- Hotel population = 1.8 person/room
- Gaming Tables = 6 seats/table

**Section 4.0 Ottawa Sewer Design Guidelines**

- Restaurant (Steakhouse, Hard Rock Café, Casual dining, incl employee allotment)
- Auditoriums (No food, incl employee allotment)
- Hotel (incl. employee allotment)
- Employees (Excluding Hotel, Casio Floor, Live, and Restaurant Employees)

**Novatech Daily Usage Calculation**

- OLG Slots (calculated based on existing usage)
- Gaming Tables (based on existing slots calculation)
- Commercial Peaking Factor (Section 4.0 Ottawa Water Distribution Guidelines)

Max. Daily Demand:

Peak Hourly Demand:

Residential Peaking Factor (Section 4.0 Ottawa Water Distribution Guidelines)

Max. Daily Demand:

Peak Hourly Demand:

125	L/seat/day
20	L/seat/day
225	L/person/day
75	L/person/day
32	L/slot/day
32	L/seat/day
1.5	x Avg. day
1.8	x Max. day
2.5	x Avg. day
2.2	x Max. day





**SNC • LAVALIN**

2140 Regent St. South, Unit 12A  
Sudbury, Ontario, Canada, P3E 5S8  
☎ 705.675.6881 📠 705.675.8330

City of Ottawa  
110 Laurier Ave. West  
Ottawa, Ontario K1P 1J1

Project No. **2019-667797**

April 23, 2020

Attention: **Ms. Terri Hunt**  
**Program Manager, Permits Approval**  
**Building Code Services**

Fax: 613-580-2495

**Mr. Allan Evans**  
**Fire Protection Engineer**  
**Ottawa Fire Department**

**Mr. Akhil Kumar**  
**Engineer**  
**Building Code Services**

Re: **Hardrock Ottawa Phase 2 Expansion Casino and Hotel**  
**Fire Protection Water Supply**  
4837 Albion Road  
Ottawa, Ontario

Hello Terri / Allan / Akhil

Further to our previous letter and discussions with Allan Evans the following information has been updated to include the latest requests for fire-fighting services at the site. Required capacities for the building's fire protection systems are based on the most recent design development drawings for the building.

#### Fire Suppression Facilities

A capacity of 100,000 US gallon / 378,500 L water is required for the fire protection systems serving the entire building (existing and new). This will be achieved by combining the capacities in the existing 30,000 US gallon / 113,500 L buried tank (see attached drawing Appendix A which shows this set of tanks as well as the larger tank noted below) serving the existing building fire protection systems and the 90,900 gallon / 344,100 L buried tank which presently serves as a plenum of water available for the fire department to pull from. Both tanks are located to the North of the existing building. The existing dry hydrant connected to the larger of the two tanks will remain in place as a secondary drafting point for use by the fire department. A recently completed report on the larger of the tanks is attached which confirms it's dimensions and capacity (Appendix B).



The combined storage tank system will provide the required capacity for all required areas of coverage and includes a total hose allowance (inside and outside) of 500 USGPM for use by the fire department meeting both the requirements of NFPA 13 and the OBC for on-site storage. The on-site wells will be used to top up the tanks as needed. The tanks will be monitored for level and temperature as required by NFPA 25.

A new fire pump meeting NFPA 20 requirements will draw from this tank system to provide the flow and pressures necessary to meet the requirements of NFPA 13 and NFPA 14 for all areas of the entire building (presently estimated at 1250 USGPM). A common sprinkler and standpipe header serving all areas of the building will be installed and pressurized by the new pump.

It has been confirmed that the Ottawa Fire Service pumper trucks have the capacity to boost the pressure in the standpipe system through the new siamese connection to provide the 100 psi pressure required at the top of the Hotel portion of the building so a second booster pump will not be required.

The existing 500 USGPM fire pump connected to the buried 30,000 US gallon tank which serves the existing building will become redundant for NFPA fire protection purposes and will be removed from service.

A new 70,000 US gallon / 265,000 L buried water storage tank will be provided in the parking area to the South of the new addition for fire department use and will be monitored for level and temperature as required by NFPA 25. The tank will be provided with two pull ports for use by fire department pumper vehicles and connections for refill from tankers (refer to Appendix C).

A series of dry hydrants located around the site will allow the fire department trucks to provide pressurized water to various draw points around the site (refer to Appendix C).

## Fire Events

In the event of a fire the fire alarm system will alarm and the building will be evacuated.

If a sprinkler head in the building is set off or a fire hose cabinet put into use, the system pressure will drop. The jockey pump will run to maintain pressure and if cannot keep up the fire pump will be automatically activated. It will draw water from the combined storage tanks at the North end of the building to pressurize the combined sprinkler / standpipe system throughout the building.

The pump capacity of 1250 US gpm is sized to meet the requirement of both NFPA 13 and NFPA 14 and includes a flow of approximately 325 US gpm (to be finalized at the time of final sprinkler design) for sprinklers and the remainder for the standpipe system for fire-fighting purposes through the standpipe system.

As the level drops in the tank the floats will open the make up water valves fed from the wells and water will be added to the tanks and will continue to flow until the top up levels are reached.

Both during and following a fire event the tanks would be filled up using the water supplied from the wells on site. Data from previous tests on the wells that are in place that maintain water levels in these two tanks identifies an available flow of 100 gallons per minute. Similarly, water supply trucks can be brought in to re-fill the tank during or after a fire.

The fire department will be able to arrive on site and set up adjacent to the new 70,000 US gallon storage tank to the South of the building. The pumper trucks will connect to the pull ports at the tank and pressurize the dry hydrant system provided or set their own lines as required. The tanks are provided with refill connections and will be replenished with tanker trucks as needed.

Should the city allow the use of the domestic water feed to the site as an additional source of water during a fire, it can be used:

- a) as a direct source of pressurized water to a designated hydrant on site for pumper trucks to connect to;
- b) as a source of water to refeed the buried storage tanks to add capacity to extend the draw down time to the sprinkler / standpipe system through the fire pump or to the tank used for drafting of water by the fire department pumper truck

If you have any further questions or require additional clarifications please feel free to contact me.

**SNC-LAVALIN INC.**  
Buildings Ontario

per:   
\_\_\_\_\_  
Jeff Hunter, P. Eng.  
Mechanical Director



Appendix A

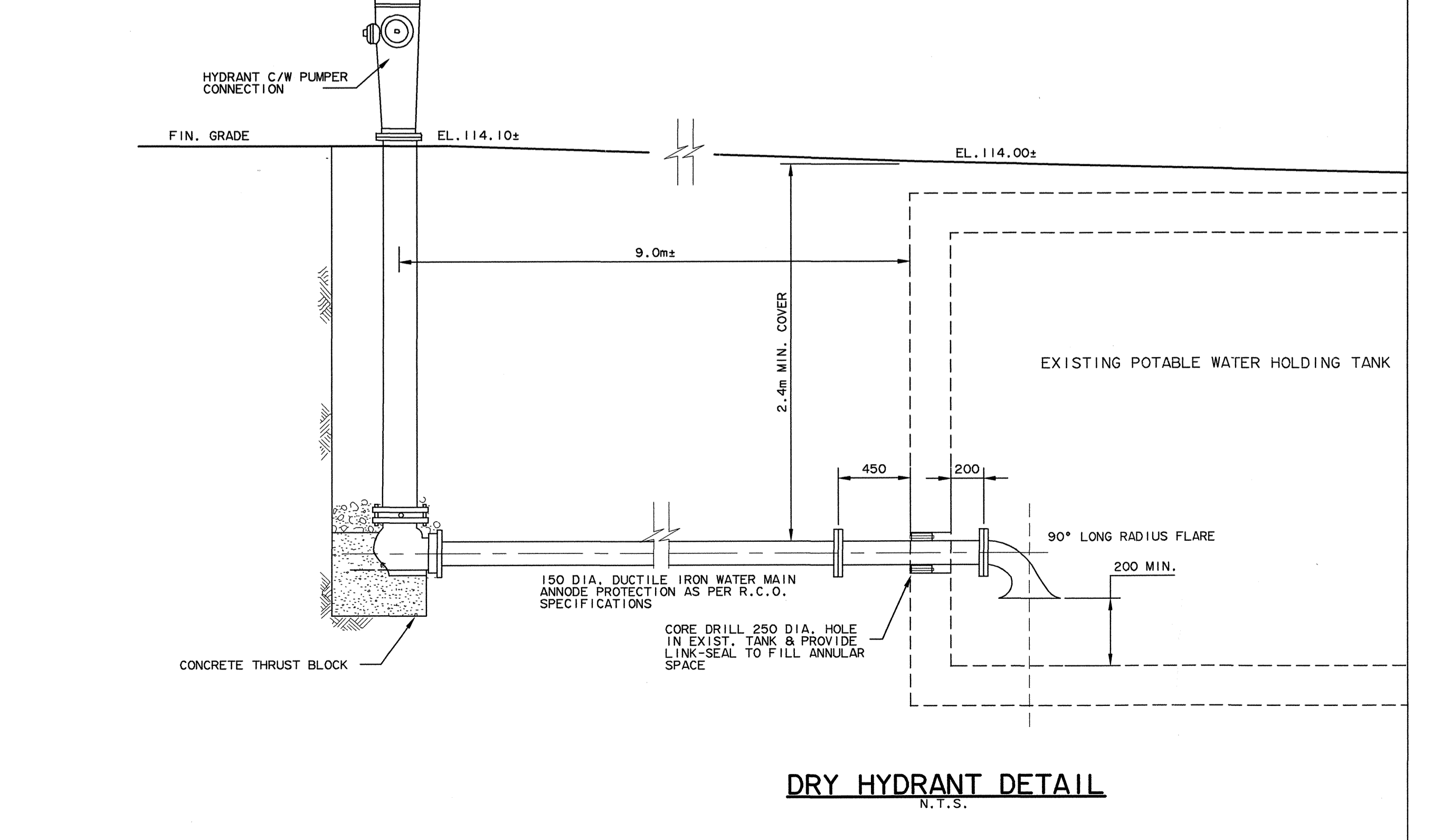
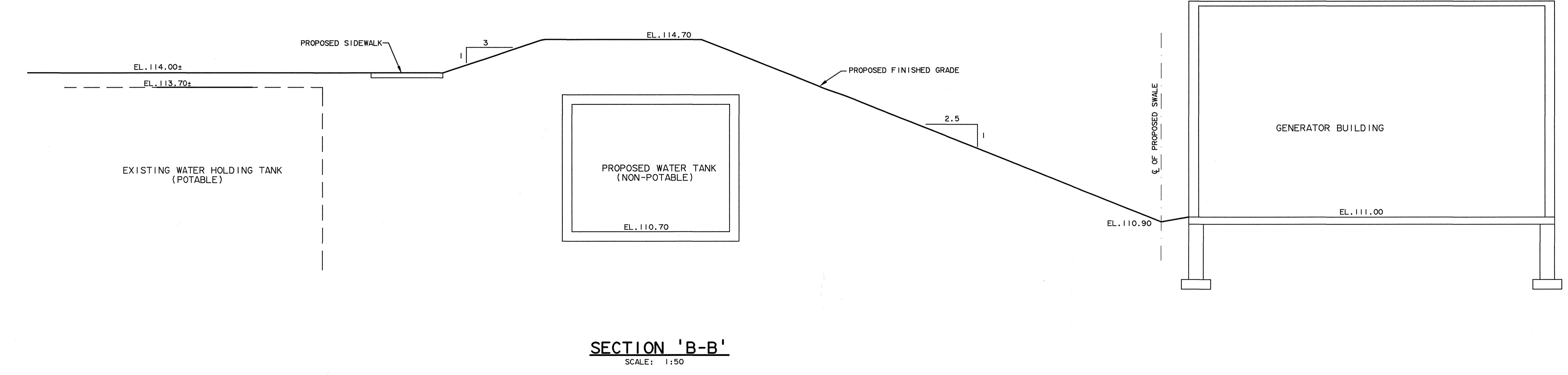
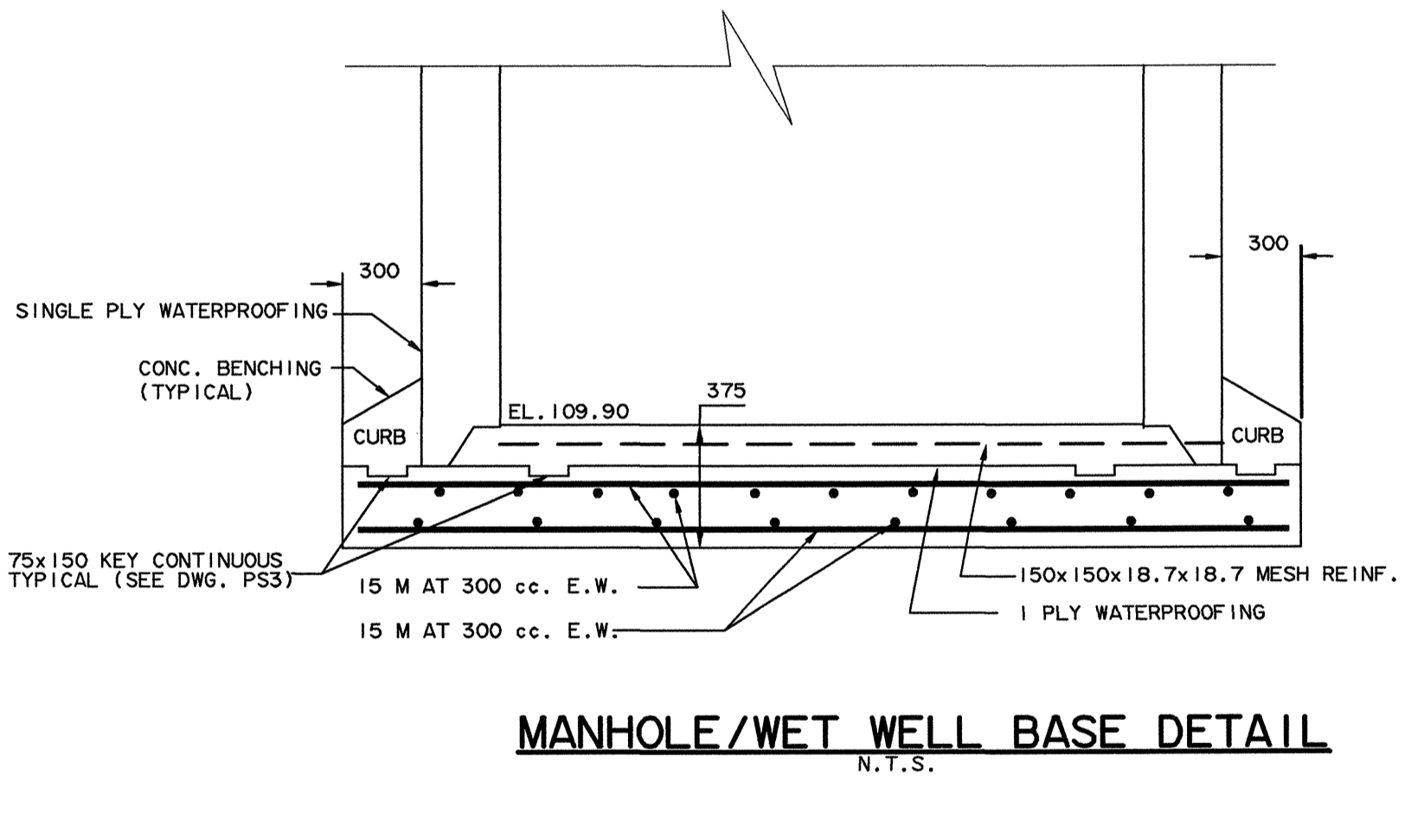
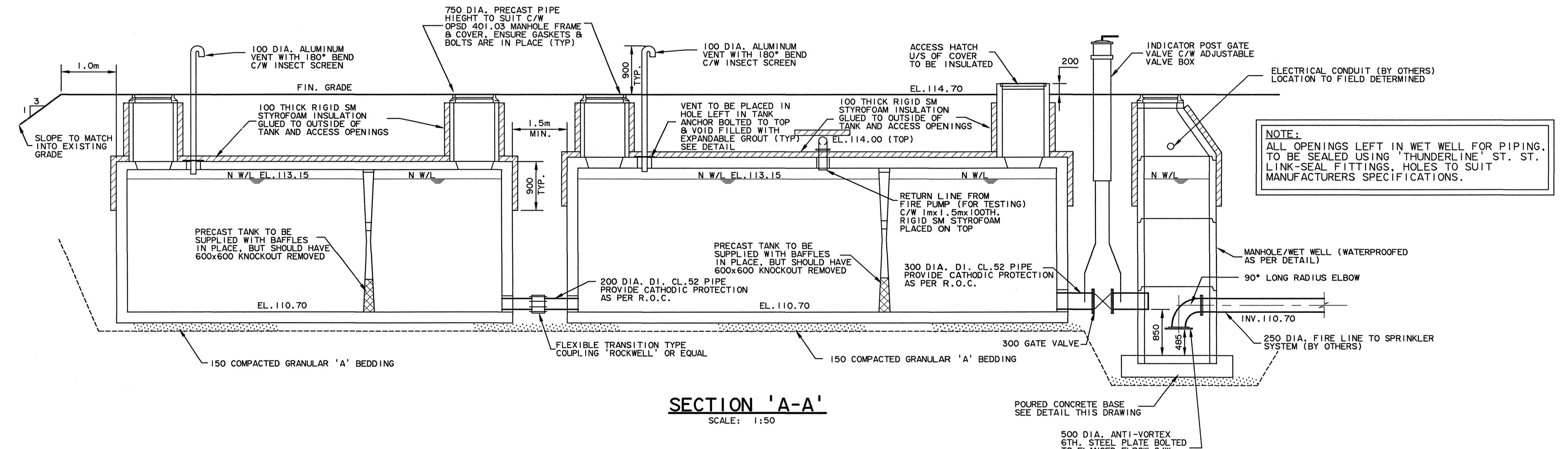
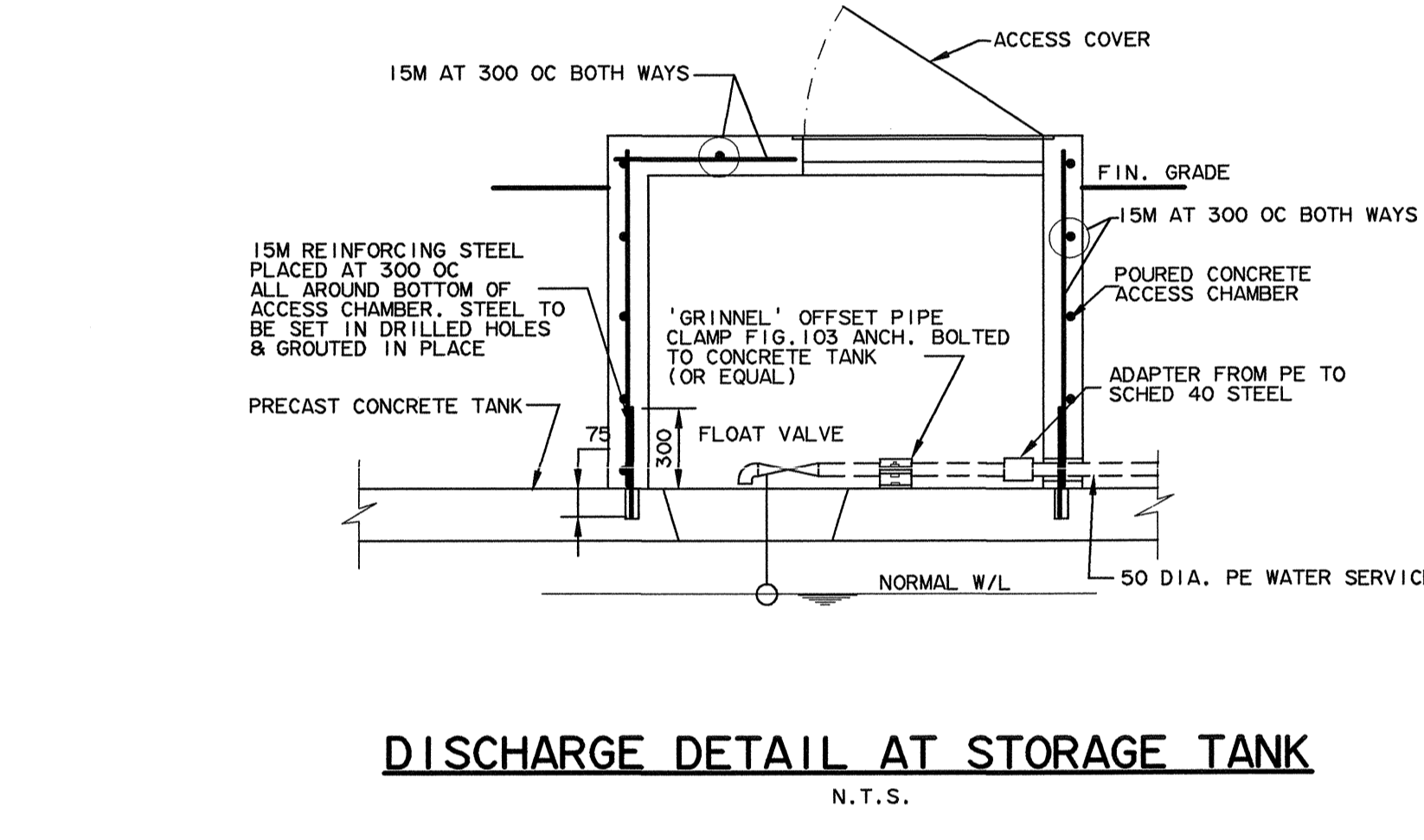
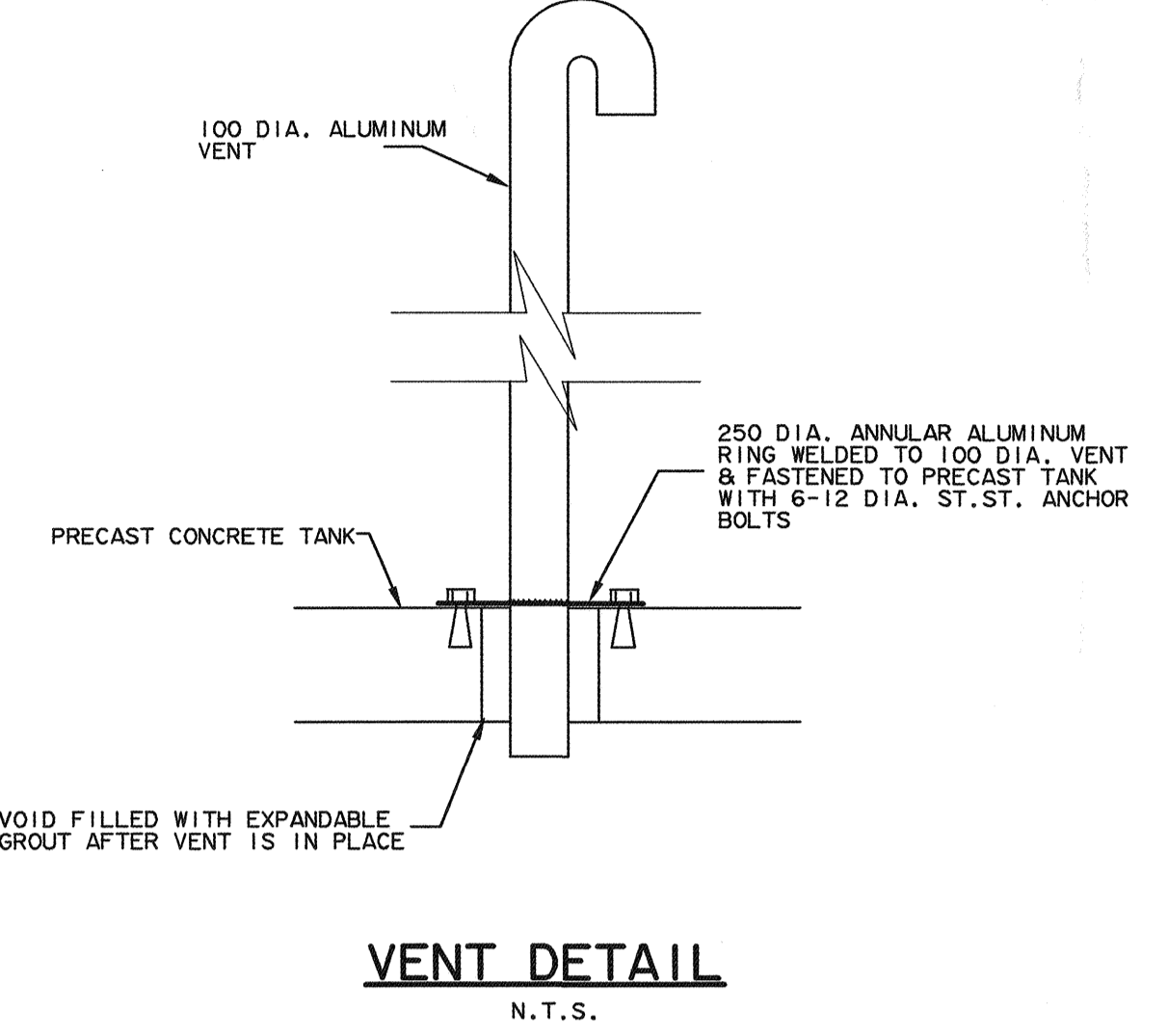
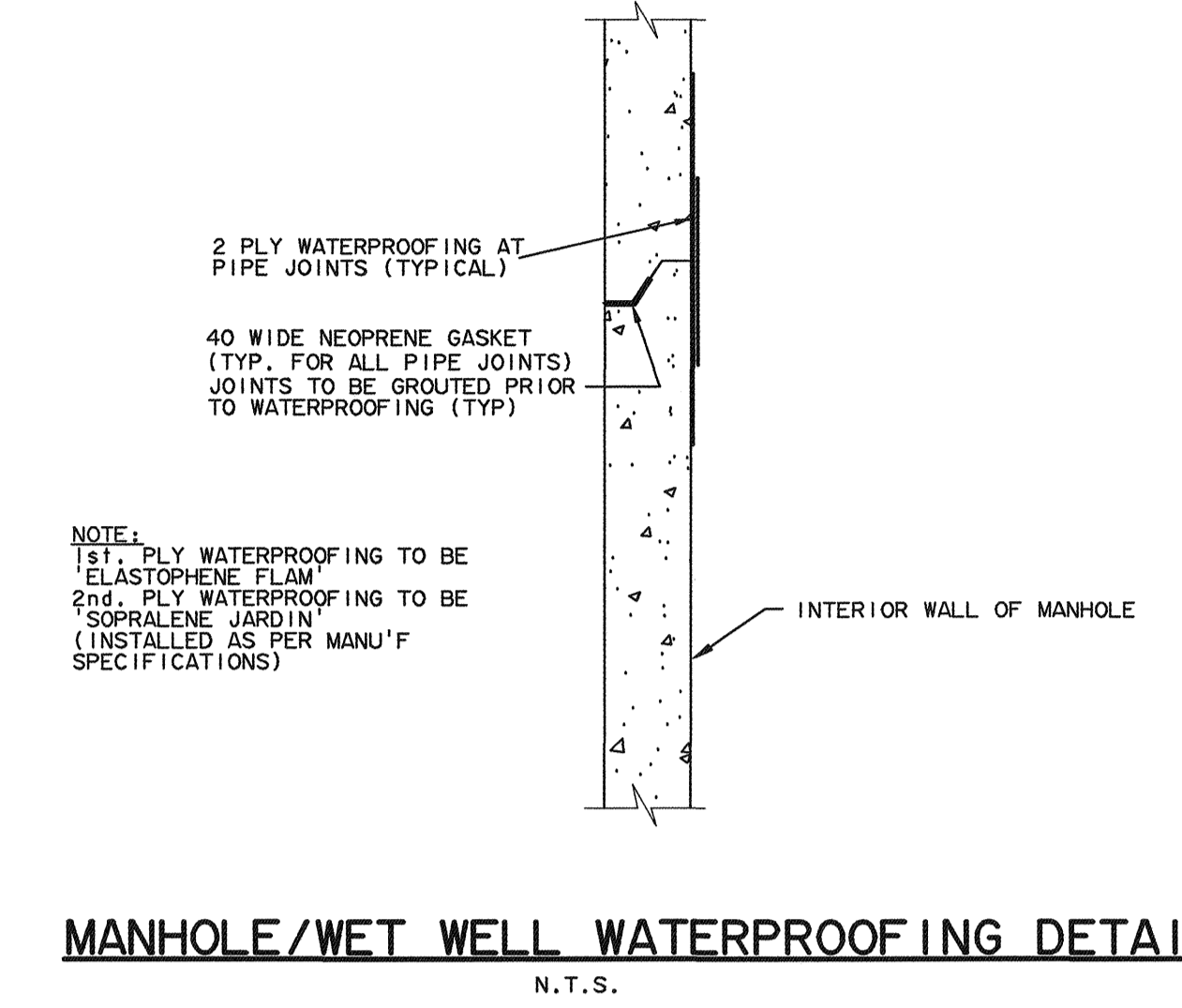
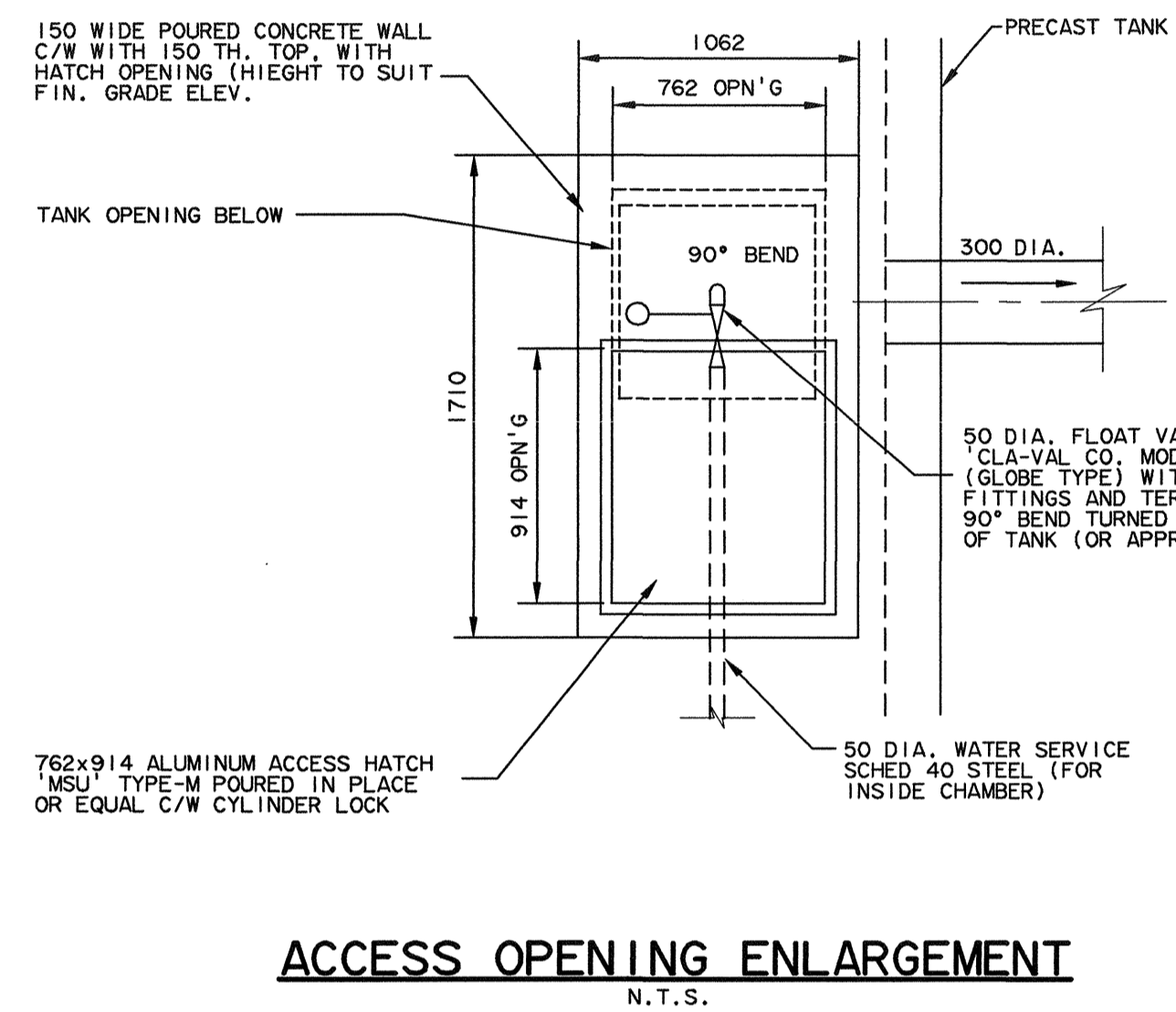
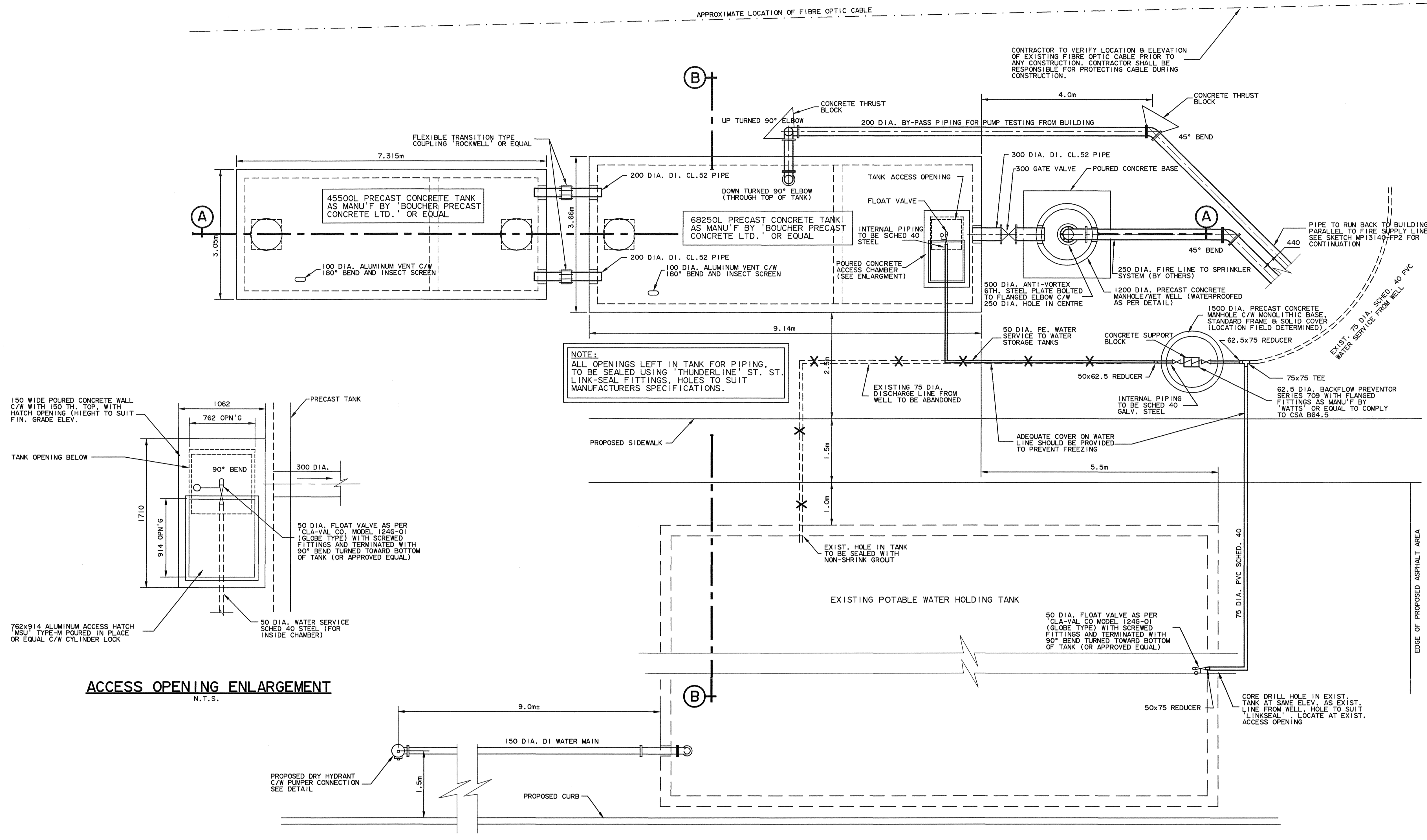

NO.	DESCRIPTION	DATE	BY
1	WATER SUPPLY RELOCATED	25/11/99	G.J.R.
4	GENERAL REVISIONS	17/11/99	G.J.R.
3	GENERAL REVISIONS	22/10/99	G.J.R.
2	ADDED CHAMBER DETAILS	8/10/99	G.J.R.
1	RAISED PL. GENERATOR BLDG.	1/10/99	G.J.R.

PROFESSIONAL ENGINEER  
D.F. MCGOVERN  
PROVINCE OF ONTARIO

PROFESSIONAL ENGINEER  
D.W. SMITH  
PROVINCE OF ONTARIO

**OMM Trow**  
A TROW COMPANY  
CONSULTING ENGINEERS,  
HYDROGEOLOGISTS & PLANNERS

Oliver, Mangione, McCalla & Associates  
a division of Trow Consulting Engineers Ltd.  
154 COLLENAISE RD., S. NEPEAN ONTARIO  
PHONE (613) 225-9940  
FAX (613) 225-7337

P.B.K. ARCHITECTS

PROJECT: RIDEAU CARLETON RACEWAY

TITLE: FIRE PROTECTION WATER TANKS

DESIGNED BY: G.J.R. DRAWING NO.: 10113/40A  
 DRAWN BY: G.J.R.  
 CHECKED BY: C.B.W.  
 DATE: SEPT, 1999  
 AS SHOWN

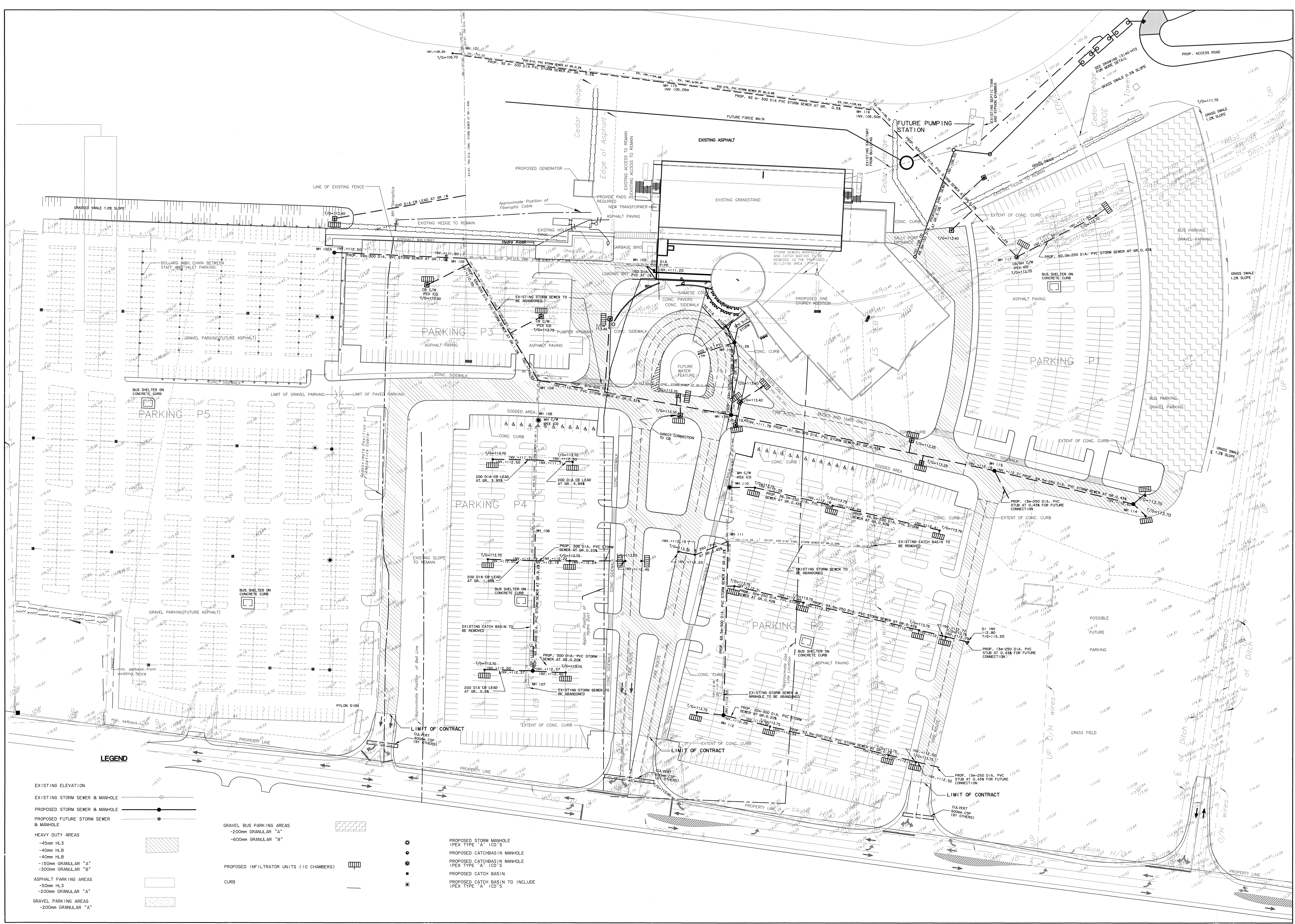

- 6 NEW CURB LAYOUT 4/10/99 C.B.
- 5 ADDED EXISTING UTILITIES 29/09/99 AM
- 7 REVISED SITEPLAN 22/09/99 AM
- 8 ADD MH 102A 03/09/99 AM
- 4 ISSUED FOR SITE PLAN AGREEMENT AND TENDER 27/08/99 AM
- 3 REMOVE STORM SEWERS 16/07/99 AM
- 2 AS PER CITY OF GLOUCESTER 6/08/99 AM
- 1 ROTATED HATCHING 21/06/99 MF

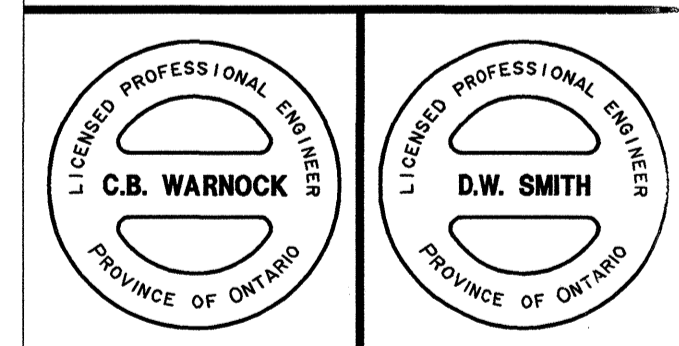

154 COLONNADE RD. S. NEPEAN ONTARIO  
PHONE (613) 225-9940  
FAX (613) 225-7337

P.B.K. ARCHITECTS

RIDEAU CARLETON RACEWAY

SITE SERVICING PLAN

DESIGN BY C.B.W. DATE 15/09/99  
DRAWN BY A.M.C. DRAWING NO. SS1  
CHECKED BY C.B.W. DATE JUNE 1999  
SCALE 1:500

Appendix B

# H. O. Wright & Sons Ltd.

2383 Church Street, P.O. Box 129  
North Gower, ON  
K0A 2T0

Tel: 613- 489-3372  
Fax: 613- 489-2593

ECRA/ESA LIC. # 7002328  
WELL CONTRACTOR LIC. # 6357

EMAIL: [gpratt@howright.ca](mailto:gpratt@howright.ca)

Quality Sales and Service Since 1954

Plumbing - Electrical - Well Systems - Myers Pumps and Water Treatment

---

March 9,2020

Hard Rock Ottawa  
4837 Albion Road  
Ottawa,Ontario

RE: Underground water storage tank

As a summary of our findings, we entered the tank which is constructed of poured concrete and measures 42' - 6" long ( north to south) and 30' - 1" wide ( east to west) and 9' - 6.5" deep.

There are 4 structural support columns that measure 12" X 12" that run from floor to ceiling that are positioned as per the drawing. The concrete is in excellent condition and there is no visible deterioration of the concrete. There are a number of penetrations through the walls of piping as indicated on the drawing. The only defect that could be noted is at the north end about 10 feet from the east side wall at the top of the tank there is a root mass from the tree (hedge) that has grown into the tank in search of water. To stop any further growth of this mass I would suggest that the end of the tank be excavated , the source of the roots removed and the end of the tank sealed from the exterior.

A calculation of water volume that the tank would hold if full to the top would be approximately 75,500 imperial gallons or 344,100 litres.

Pictures were taken of the inside of the tank, but due to the poor lighting the quality is not great. They have been sent by email to Richard Gardner.

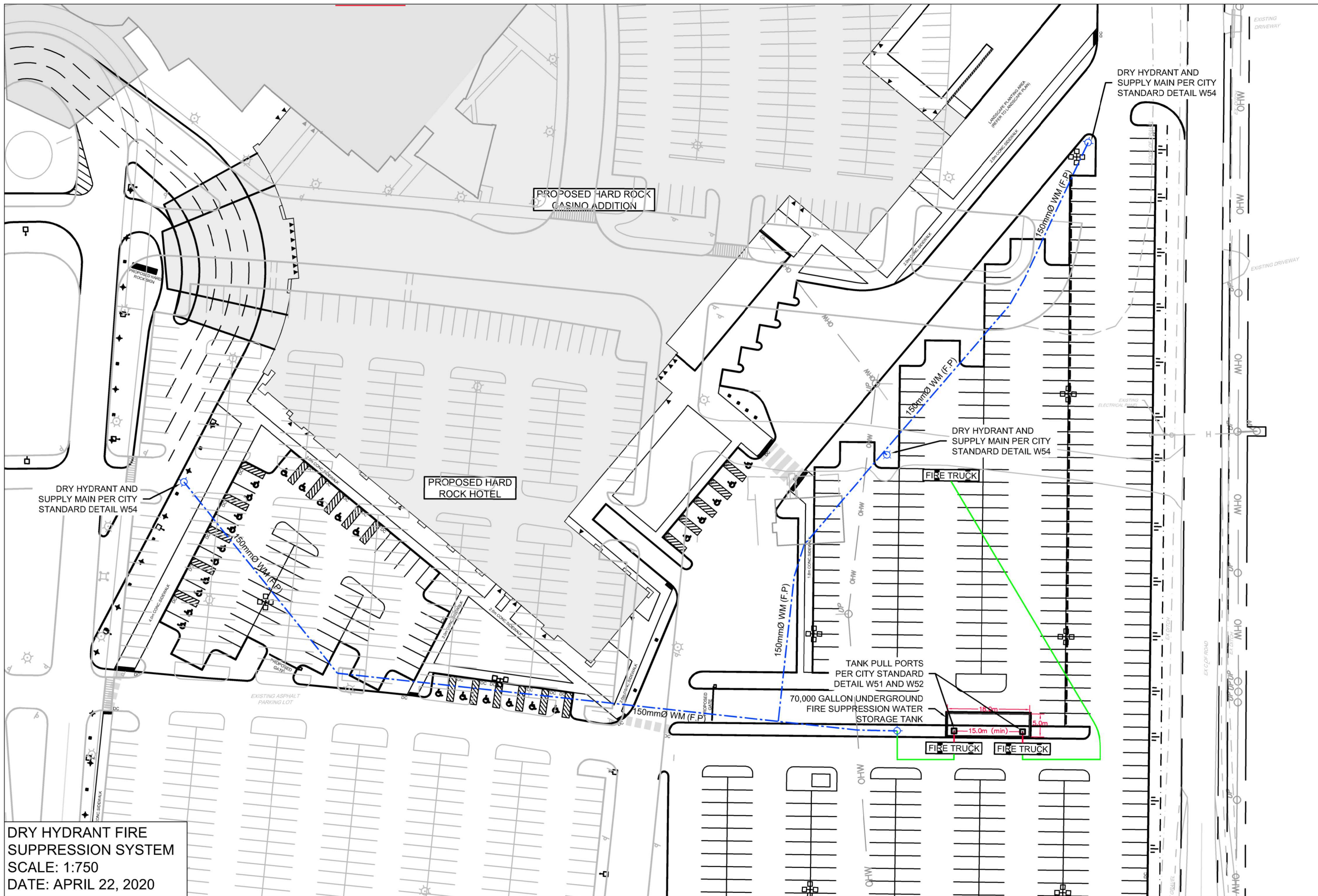

DRY HYDRANT FIRE  
 SUPPRESSION SYSTEM  
 SCALE: 1:750  
 DATE: APRIL 22, 2020

## Boundary Conditions 4837 Albion Road

### Information Provided

Date provided: 30 Jan 2020

Scenario	Demand	
	L/min	L/s
Average Daily Demand	269.4	4.49
Maximum Daily Demand	454.8	7.58
Peak Hour	868.8	14.48
Fire Flow Demand	0	0

- It is understood that these demands represent the total future demands for the property, including the existing demands associated with the Rideau Carleton Raceway

### Location

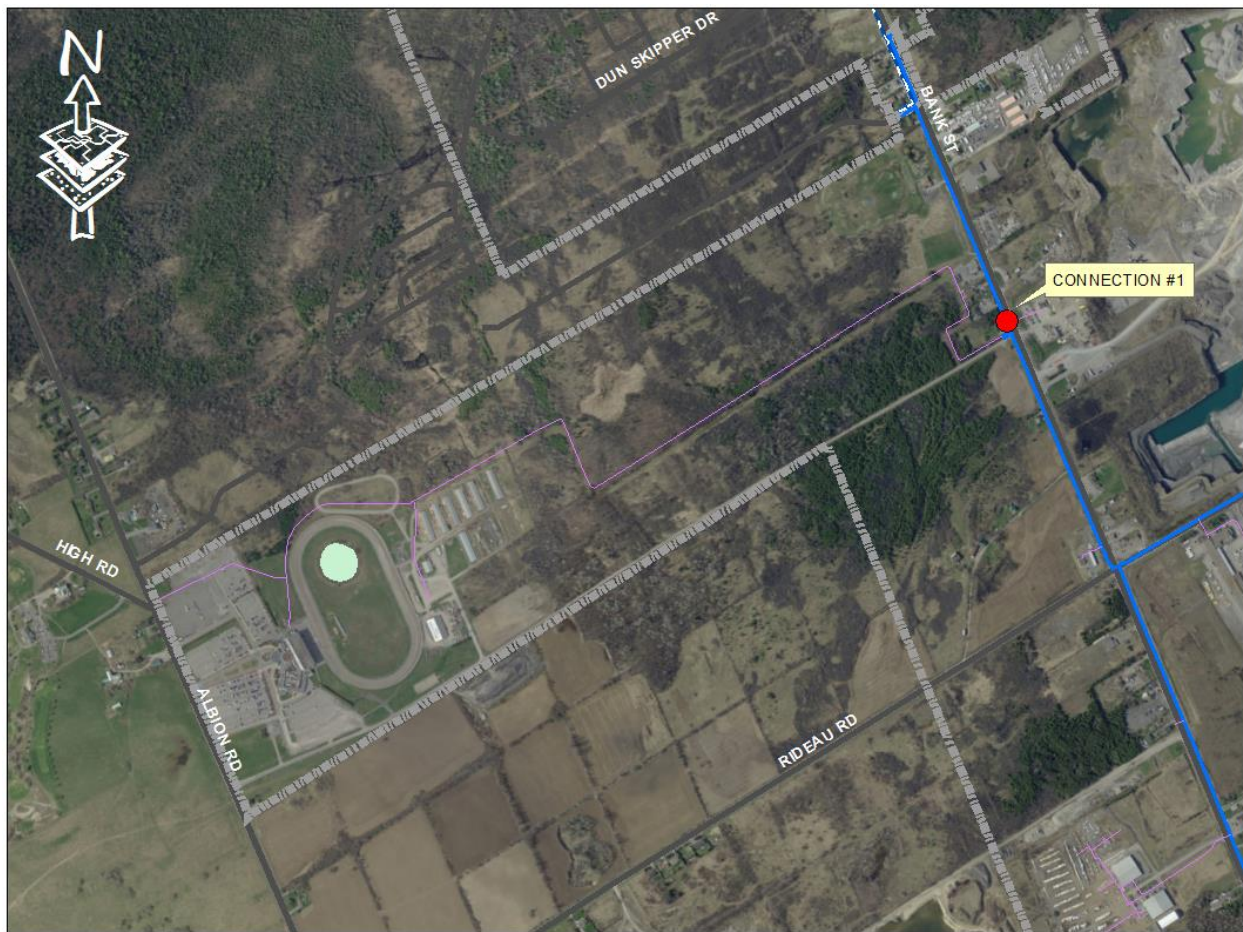



## Results

### Under Existing Condition

#### Connection 1 - 4837 Albion Connection (N12551)

Demand Scenario	Head (m)	Pressure <sup>1</sup> (psi)
Maximum HGL	164.9	67.7
Peak Hour	151.9	49.1
Max Day	163.3	65.4

<sup>1</sup> Ground Elevation = 117.3 m

### With Future SUC Zone Reconfiguration

#### Connection 1 - 4837 Albion Connection (N12551)

Demand Scenario	Head (m)	Pressure <sup>1</sup> (psi)
Maximum HGL	164.9	67.7
Peak Hour	143.7	37.5
Max Day	163.3	65.4

<sup>1</sup> Ground Elevation = 117.3 m

## Notes

A second pump can be turned ON at Leitrim PS, if the peak hour pressure is low.

## Disclaimer

*The boundary condition information is based on current operation of the city water distribution system. The computer model simulation is based on the best information available at the time. The operation of the water distribution system can change on a regular basis, resulting in a variation in boundary conditions. The physical properties of watermains deteriorate over time, as such must be assumed in the absence of actual field test data. The variation in physical watermain properties can therefore alter the results of the computer model simulation. Fire Flow analysis is a reflection of available flow in the watermain; there may be additional restrictions that occur between the watermain and the hydrant that the model cannot take into account.*

```

*****
*                               E P A N E T                               *
*                               Hydraulic and Water Quality                 *
*                               Analysis for Pipe Networks                 *
*                               Version 2.2                               *
*****
    
```

Input File: High Pressure.net

Link - Node Table:

Link ID	Start Node	End Node	Length m	Diameter mm
1	1	2	425	200
2	2	3	1010	200
3	3	4	700	200
4	4	5	410	200
5	5	6	160	200
6	5	7	340	200

Node Results:

Node ID	Demand LPS	Head m	Pressure m	Quality
2	0.00	164.86	52.86	0.00
3	0.00	164.78	57.48	0.00
4	0.00	164.72	60.72	0.00
5	0.00	164.69	56.19	0.00
6	3.05	164.67	50.67	0.00
7	0.00	164.69	48.19	0.00
1	-3.05	164.90	0.00	0.00 Reservoir

Link Results:

Link ID	Flow LPS	Velocity m/s	Unit Headloss m/km	Status
1	3.05	0.10	0.08	Open
2	3.05	0.10	0.08	Open
3	3.05	0.10	0.08	Open
4	3.05	0.10	0.08	Open
5	3.05	0.10	0.08	Open
6	0.00	0.00	0.00	Open

# HIGH PRESSURE

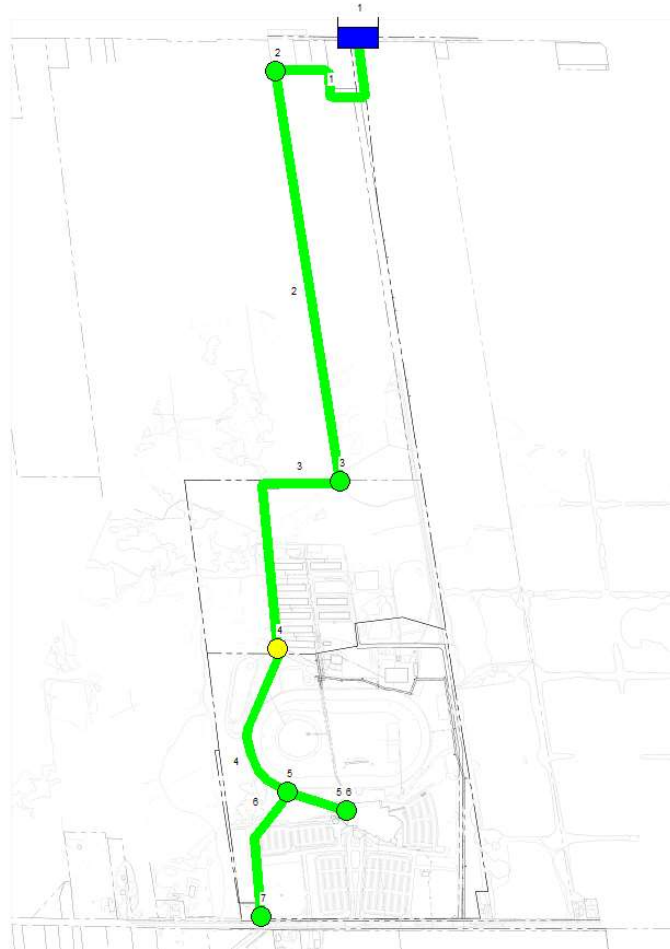
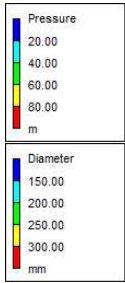

```

*****
*                               E P A N E T                               *
*                               Hydraulic and Water Quality                 *
*                               Analysis for Pipe Networks                 *
*                               Version 2.2                               *
*****
    
```

Input File: Peak Hour.net

Link - Node Table:

Link ID	Start Node	End Node	Length m	Diameter mm
1	1	2	425	200
2	2	3	1010	200
3	3	4	700	200
4	4	5	410	200
5	5	6	160	200
6	5	7	340	200

Node Results:

Node ID	Demand LPS	Head m	Pressure m	Quality
2	0.00	151.57	39.57	0.00
3	0.00	150.77	43.47	0.00
4	0.00	150.22	46.22	0.00
5	0.00	149.90	41.40	0.00
6	10.21	149.78	35.78	0.00
7	0.00	149.90	33.40	0.00
1	-10.21	151.90	0.00	0.00 Reservoir

Link Results:

Link ID	Flow LPS	Velocity m/s	Unit Headloss m/km	Status
1	10.21	0.32	0.78	Open
2	10.21	0.32	0.78	Open
3	10.21	0.32	0.78	Open
4	10.21	0.32	0.78	Open
5	10.21	0.32	0.78	Open
6	0.00	0.00	0.00	Open

# PEAK HOUR

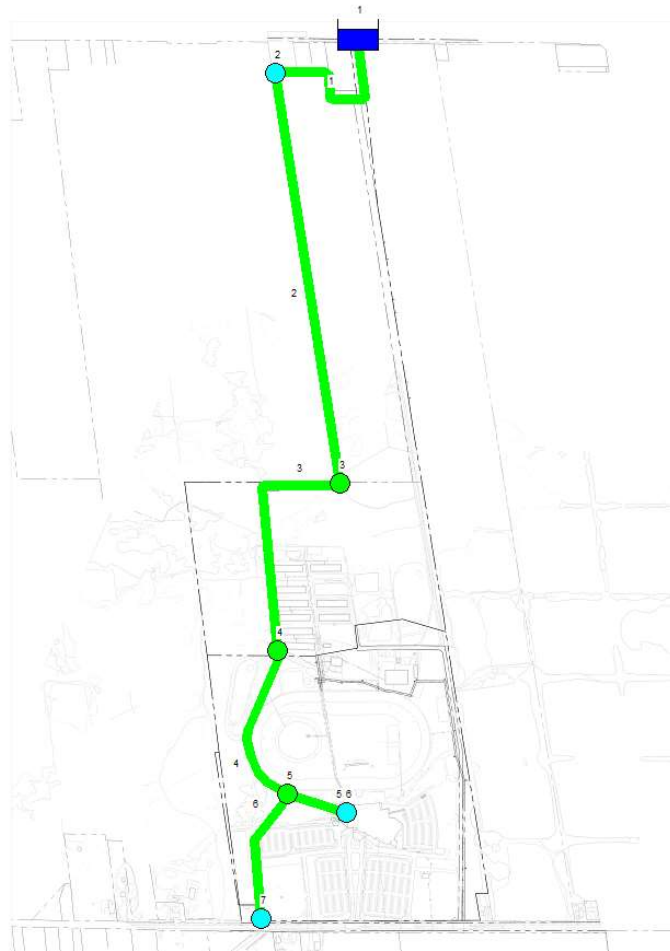
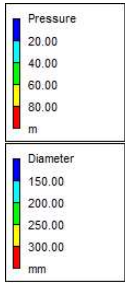

**Appendix B**  
Sanitary Servicing Information

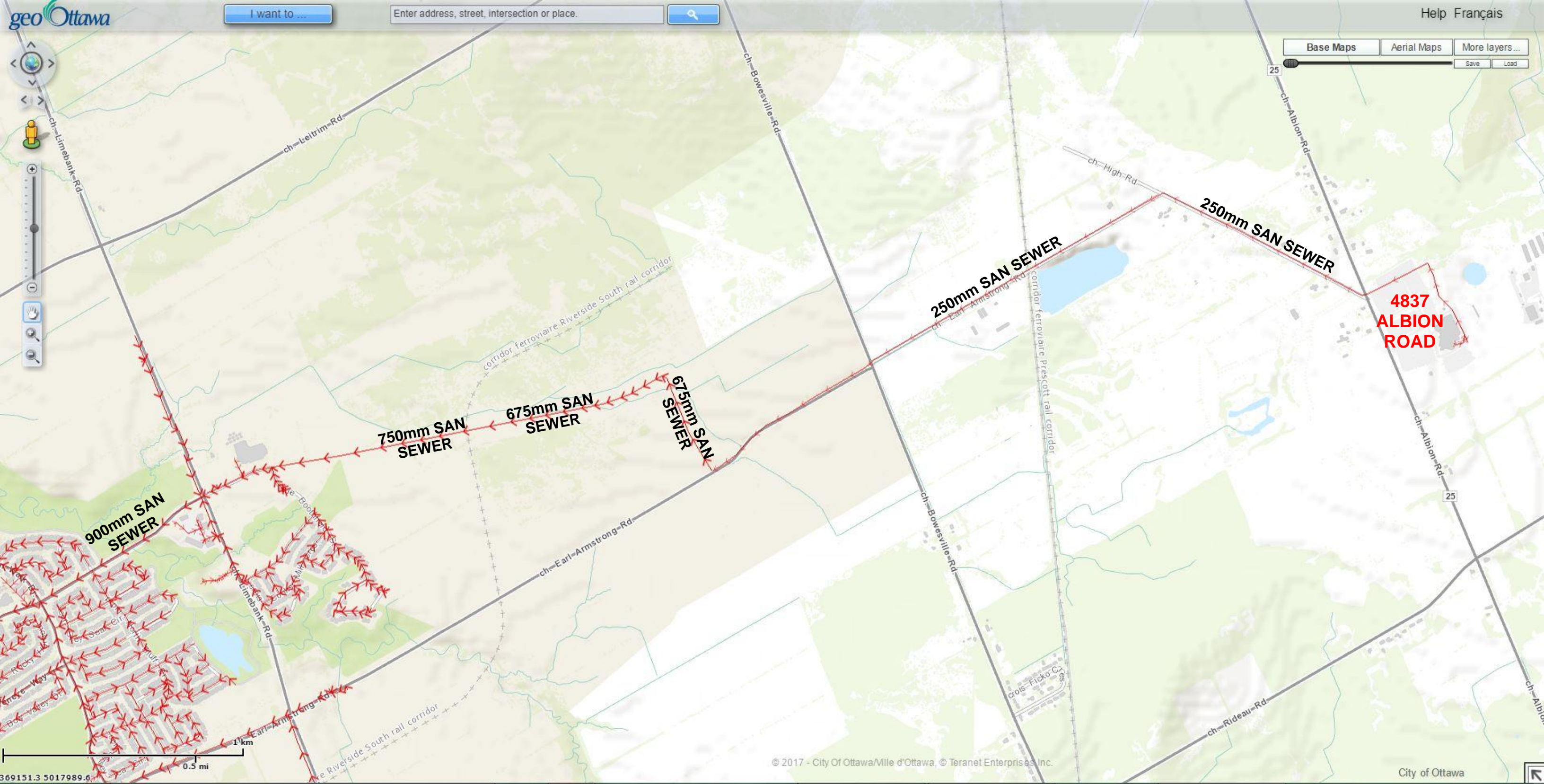

**HARD ROCK OTTAWA  
RIDEAU CARLETON RACEWAY  
SANITARY FLOW ANALYSIS**

**Table 4.0: Sanitary Flow Calculations Existing and Proposed Development**

Location	Existing Flow	Hard Rock Auditorium	Restaurant Additions	Gaming Positions	Employee Additions	Hotel Addition		Total Phase Restaurant / Casino Flow (L/s)	Total Phase Hotel Flow (L/s)	Peak Flow				Infiltration		Peak Design Flow (l/s)	PIPE					
						No. Rooms	Total Population			Commercial Peak Factor	Residential Peak Factor	Phased Peak Flow (l/s)	Total Peak Flow (l/s)	Development Area (ha)	Infil. Flow (l/s)		Size (mm)	Slope (%)	Length (m)	Capacity (l/s)	Full Flow Vel. (m/s)	Q/Q <sub>full</sub> (%)
Existing 4837 Albion	1.01							1.01	0.00	1.5	N/A	1.52	1.52	14.74	4.13	5.65	250	0.28	N/A	31.4	0.64	18.0%
Hard Rock Casino Addition		1800	350	580	230	150	270	1.34	0.70	1.5	3.2	4.25	5.77	14.74	4.13	9.90	250	0.28	N/A	31.4	0.64	31.5%

\*Note: Sanitary flows for the Phase 2 additions include the phase 1 interim additions

**Design Parameters:**

- Hotel population = 1.8 person/room

- Gaming Position = 6 seats/position

Section 4.0 Ottawa Sewer Design Guidelines

- Restaurant (Steakhouse, Hard Rock Café, Casual dining, incl employees)

125 L/seat/Day

- Auditoriums (No food, incl employees)

20 L/seat/Day

- Hotel (incl employees)

225 L/person/day

- Employees (Additional employees not included in above uses)

75 L/person/day

Novatech Daily Usage Calculation

- OLG Slots (calculated based on existing usage)

32 L/slot/day

- Gaming Tables (based on existing slots calculation)

32 L/seat/Day

Commercial Peaking Factor (Section 4.0 Ottawa Sewer Design Guidelines)

1.5

Residential Peaking Factor (Section 4.0 Ottawa Sewer Design Guidelines)

Harmon Formula

Section 4.0 Ottawa Sewer Design Guidelines

- Extraneous Flows

0.28 L/s/effective gross ha



# TECHNICAL MEMORANDUM

---

**DATE:** NOVEMBER 1, 2019  
**TO:** FILE  
**FROM:** CARL SCIUK  
**RE:** JOB#116111: HARD ROCK CASINO – SANITARY PUMP STATION EXISTING CONDITIONS

---

The following technical memorandum will review condition of the Sanitary Pump Station which services this site:

The sanitary pump station is located approximately 240m north of the main building. Sewage is conveyed to the pump station via a 250mm gravity sewer. The station pumps sewage approximately 325m via a 150mm force main to an existing gravity sewer at the intersection of Albion Road and High Road [Drawings attached].

DME prepared a design report for the pump station in October 2005 [attached]. The report includes details of forcemain sizing, wet well sizing [for up to 20.64L/s], and pump sizing to accommodate a design flow of 17.2L/s and future flow of 20.64L/s.

The station consists of a control panel, fibreglass wet well, two submersible pumps, an ultrasonic level controller and floats [Refer to Xylem Sanitary Lift Station drawing attached]. The submersible sewage pumps [Flygt NP-3102-463] are each rated for peak flow of 17.2L/s and alter between duty and standby on each pump cycle. It appears the pumps operate primarily by ultrasonic levels, with floats providing backup control and high alarms. A high water alarm is wired to the central monitoring of the building. The pump station is connected to standby power which serves the entire facility in the event of a power outage. The wet well and associated equipment was installed in 2006. The wet well and associated control panel were supplied by Xylem. The wet well and associated internal equipment has been constructed to standards typical for municipal pump stations in Ottawa.

The wet well and control panel are accessed from the main parking lot via a 50m long gravel access pathway. The access pathway currently shows signs of surface erosion. The pathway should be maintained in good condition and plowed in the winter to ensure access for maintenance and emergencies. The pathway ends approximately 5m from the wet well and should extend closer to the wet well to ease both foot and vehicular access. The access hatches were not locked at the time of visit, but facility staff noted that locks will be installed soon. The control panel is located above grade on support posts and was locked. No documents for the facility were in the control panel.

We are not aware of any protocol for response to a high level alarm condition. The facility should ensure that the emergency contact is able to address alarms in a timely manner. Response should include procedures to follow at the pump station to evaluate and mitigate the issues, as well as contact with a service qualified technician and possibly a septic hauler.

There was no information available about past maintenance of the pump station. The inside of the wet well was quite grimy, and the inlet trash basket was full of debris. We recommend that a

maintenance contract with a minimum of quarterly site visits should be arranged. The site visits should include as a minimum: confirmation of each pump operation, confirmation of ultrasonic level control, confirmation of alarm floats & registration of high alarm at building control room, cleaning of trash basket and provision for emergency response. The initial site visit should also include a cleaning of wet well internals to clear off slime buildup.

The submersible sewage pumps are likely original and near the end of their service life. The pumps should be evaluated and upgraded prior to servicing the new facility. The wet well includes pump rails, a pump base and pump chain, so that pumps can easily be removed and replaced/upgraded to new station capacity if required without entering the wet well.

## **Conclusion**

Based on the foregoing, the sanitary pump station is adequately designed and sized to service 17.2L/s [with capability to upgrade via pump impeller changes to 20.64L/s]. We recommend the following actions be taken to address existing conditions:

- Lock access hatches. Use a common key system for all padlocks including the control panel.
- Provide Operation and Maintenance documentation including: drawings of facility/control panel, protocol for emergencies, etc at the pump station.
- Improve access in the immediate vicinity of the pump station and maintain the gravel access road in both summer and winter
- Engage a qualified service contractor to make quarterly visits as a minimum. The service agreement should include reasonable emergency response times.
- Upgrade submersible pumps if required to meet sanitary service demands for the proposed hotel.

**NOVATECH**

Prepared by:

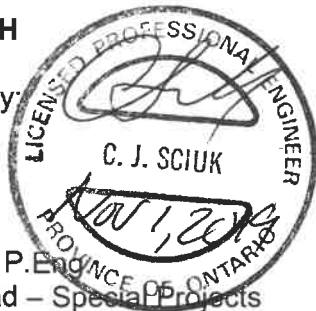

Carl Sciuk, P.Eng.  
Project Lead – Special Projects

**Enclosed**

**Sanitary Sewage Report by DME, October 6,2005**  
**Xylem “Rideau Carleton Raceway Lift Station” Drawing, Rev 3**  
**Site Drawing 2538-OS-P1, Rev 8**  
**Site Drawing 2538-OS-P2, Rev 9**

# **Sanitary Sewage Report**

## **Rideau Carleton Raceway**

**D.M.E. Project No. 2538**

**Prepared by:**



**David McManus**  
**Engineering Ltd.**

**September 12, 2005**

**Revised: October 6, 2005**

## TABLE OF CONTENTS

<b>1.0</b>	<b>INTRODUCTION .....</b>	<b>1</b>
<b>2.0</b>	<b>EXISTING CONDITIONS .....</b>	<b>1</b>
<b>3.0</b>	<b>PROPOSED DEVELOPMENT .....</b>	<b>1</b>
<b>4.0</b>	<b>DESIGN FLOWS.....</b>	<b>1</b>
<b>5.0</b>	<b>GRAVITY SEWER.....</b>	<b>2</b>
<b>6.0</b>	<b>SANITARY FORCEMAIN AND PUMP STATION .....</b>	<b>2</b>

### **FIGURES**

Figure 1: Key Plan

Figure 2: Site Plan

### **APPENDICES**

Appendix A: Sanitary Design Flows

Appendix B: System Hydraulics & Cycle Time Calculations

Appendix C: Electrical & Structural Info

### **DRAWINGS:**

RCR Site Overall Servicing, 2538-OS4

RCR Site Forcemain Profile, 2538-OS P1

RCR Site Gravity Sewer Profile, 2538-OS P2

Pump Station Drawing

## **1.0 INTRODUCTION**

The Rideau Carleton Raceway site is located at 4837 Albion Road within the City of Ottawa (former City of Gloucester). *Figure 1* shows the site location. The Raceway would like to upgrade its sanitary sewage system and this report is in support of the design drawings.

## **2.0 EXISTING CONDITIONS**

Sanitary sewage currently drains to two existing holding/septic tanks and tile beds. The holding tanks require pumping frequently. The existing MOE Certificate of Approval for the present system requires a more permanent solution. Also, the City of Ottawa has recently increased the hauling and dumping fees for sewage thus so the Rideau Carleton Raceway would like to upgrade its sanitary sewage system.

## **3.0 PROPOSED DEVELOPMENT**

It is proposed to install a gravity sewer from the main building to an on-site pump station. A forcemain would then be constructed from the on-site pump station to a gravity sanitary sewer at the intersection of Albion Road and High Road. A gravity sanitary sewer is to be constructed from Albion and High Road along High Road to Earl Armstrong Road and then along Earl Armstrong Road westerly to Canyon Walk Drive. This gravity sewer has been submitted for review and approval under separate cover. *Figure 2* shows the sewers within the Rideau Carleton Raceway site. The attached drawings show, in more detail, the proposed gravity sewer, forcemain and pump station within the Rideau Carleton Raceway property.

## **4.0 DESIGN FLOWS**

The Rideau Carleton Raceway has intentions of expanding their facilities. The proposed infrastructure has been designed to include any future expansion. Design flows are calculated in further detail in Appendix A and are summarized as follows:

Existing Peak Sanitary Flow = 7.51 L/s  
10 year Peak Sanitary Flow = 10.51 L/s  
20 year Peak Sanitary Flow = 20.64 L/s

## 5.0 GRAVITY SEWER

Approximately 385m of 250mm diameter gravity sanitary sewer at 0.35% is proposed from the existing building to the proposed pump station. The sewer has a capacity of 36.7L/s which is greater than the 20 year Peak Sanitary Flow predicted for the site. This gravity sanitary sewer is illustrated on dwg 2535-P1, attached.

## 6.0 SANITARY FORCEMAIN AND PUMP STATION

### 6.1 **Forcemain**

Approximately 325m of forcemain is to be installed from the pump station to the upstream manhole proposed for the gravity sewer at the intersection of Albion Road and High Road. The forcemain will be 150mm diameter in size. The forcemain size and pump has been selected such that only minimal changes may be required for servicing flows from current conditions to the predicted 20 year flows. Minor changes may be required such as changing the pump impellor.

### 6.2 **Pump Station**

The pump station is designed for a dual pump system. The pumps will be set to alternate at each cycle with the second pump starting in the event of a failure. The pump station will incorporate standard control systems with alarms in the event of a failure. All alarms will be remotely monitored in the Raceway Control room.

The total head loss is the sum of losses in the system including static head, dynamic head and fitting losses. The dynamic head loss is calculated using the Hazen Williams formula.

$$V = 0.85C_H R^{0.63} S^{0.54}$$

Where

V = velocity = Flow/Area

$C_H$  = Hazen Williams roughness coefficient (based on pipe material and age)

R = hydraulic radius (d/4 for a full pipe)

S = slope of the energy grade line (ratio of head loss to length of pipe)

The static head loss is calculated as the difference between the forcemain outlet invert and the liquid level in the wet well under given conditions. The MOE Guidelines for the Design of Sanitary Sewage Systems indicates there are three conditions to be analyzed. These conditions show the range from worst case scenario where the pump has to work the hardest to the best case scenario where the pump has to work the least.

Condition A:

Hazen Williams roughness coefficient = 120 and the water level is low in the wet well

Condition B:

Hazen Williams roughness coefficient = 130 and there is a median water level over the normal operation range in the wet well

Condition C:

Hazen Williams roughness coefficient = 140 and an overflow water level in wet well

Fitting losses are also calculated in terms of equivalent lengths of pipe per fitting.

Table 1 presents and totals the losses for a 150mm (6") forcemain. This is the amount of head that the pump must overcome in order to pump sewage at various flow rates through the pump system and forcemain. Therefore, system curves can be created for each condition and plotted with the pump performance curve to determine which pump to select.

A Flygt Pump model NP-3102-463 was selected and the system curve and pump performance curve are shown in Figure B1. A schematic of the pump station with respect to elevations is shown in Figure B2. From the pump performance curve, the pump will operated under normal conditions at a flow rate of 17.2 L/s. This flow rate is less than the estimated 20 Year Peak Flow of 20.64 L/s. Therefore, the pumps may have to be replaced to accommodate the actual 20 Year Peak Flows.

Cycle times for each of the existing, 10 year and 20 year flows are calculated and shown in Appendix B. The average cycle time should be around 10 minutes. The cycle times for the 20 Year Flows are greater than 10 minutes which is also an indication that the a different pump should be installed for the 20 Year Flows.

It is proposed to install a pre-fabricated fiberglass reinforced plastic (FRP) pumping station. The contractor is required to prepare the concrete pad for this pre-fabricated unit, connect the inlet and outlet pipes, install the pre-assembled pumps and make any necessary electrical connections. A drawing for the pump station, prepared by Barski Industries Ltd., for the pre-fabricated unit is contained at the rear of the report.

An overflow outlet has been provided to the existing holding tanks. The elevation of the overflow outlet is higher than the pump station outlet but lower and the building finished floor elevation. Refer to the Overall Servicing Drawings (dwg 2538-OS4) for more detailed information.

### **6.3 Wet Well**

The minimum size for the wet well, according to MOE criteria, is a 2.4m diameter wet well. This minimum size will be used in this case in order to have adequate cycle times. The cycle times for the given flows are calculated in Appendix B. The cycle times help determine if the float levels for the different flow rates need to be adjusted.

### **6.4 Electrical & Structural**

Electrical information in terms of ductwork required is shown on the enclosed plans and a Wiring Diagram is included in Appendix C. A detail for the structural slab required for the pump station is also included in Appendix C.

---

Cara Ruddle, P.Eng.  
Project Engineer

---

David McManus, P.Eng  
Principal



**APPENDIX A:**

**SANITARY DESIGN FLOWS**

## **Design Flows**

The existing peak sanitary flow is estimated at 3.38 L/s. This number is based on Water Consumption Reports for the peak period, which is during the summer months, and using a peaking factor of 1.5. Infiltration is calculated based on estimated areas of development and using City criteria of 0.28L/s/ha. The flows are calculated as follows:

Existing Sanitary Flow = peak flow + Infiltration

Existing Sanitary Flow =  $3.38 + (14.74 \times 0.28)$

Existing Sanitary Flow =  $3.38 + 4.13$

Existing Sanitary Flow = 7.51 L/s

The 10 Year Sanitary Flow includes a 240 room Hotel and 1500 seat Theatre which will be within the existing developed area of the property and so the infiltration is the same as for the existing flows.

10 Year Sanitary Flow = peak flow + infiltration

10 Year Sanitary Flow =  $3.38 + 1.95 \text{ (hotel)} + 1.05 \text{ (theatre)} + 4.13$

10 Year Sanitary Flow =  $3.38 + 1.95 + 1.05 + 4.13$

10 Year Sanitary Flow = 10.51 L/s

The 20 Year Sanitary Flow includes a Retail Centre, Trade Centre and Golf Course which is outside the current developed area.

20 Year Sanitary Flow = peak flow + infiltration

20 Year Sanitary Flow =  $10.51 + 7.25 + (10.26 \times 0.28)$

20 Year Sanitary Flow =  $10.51 + 7.25 + 2.87$

20 Year Sanitary Flow = 20.64 L/s

**APPENDIX B:**

**SYSTEM HYDRAULICS & CYCLE TIME CALCULATIONS**

### **Existing Flows**

Design Peak Flow = 7.51 L/s

Actual (peak) Flow = 17.2 L/s (from Pump Performance Curve)

Average Flow rate = 65% of design peak flow

Run Time =  $\frac{\text{area of wet well x (pump start level - pump stop level)}}{\text{flow rate out - average flow incoming}}$

$$\text{Run Time} = \frac{4.52 \times (105.4 - 105.05)}{17.2/1000 - 0.65 \times 7.51/1000}$$

Run Time = 128.4 seconds

Run Time = 2.14 minutes

Fill Time =  $\frac{\text{area of wet well x (pump start level - pump stop level)}}{\text{Average flow incoming - no outgoing flow}}$

$$\text{Fill Time} = \frac{4.52 \times (105.4 - 105.05)}{0.65 \times 7.51/1000 - 0}$$

Fill Time = 324.1 seconds

Fill Time = 5.4 minutes

Total Cycle Time = Run Time + Fill Time

Total Cycle Time = 2.14 + 5.4

Total Cycle Time = 7.54 minutes

Minimum Cycle Time =  $\frac{\text{area of wet well x (pump start level - pump stop level)}}{\text{Flow rate out - no incoming flow}}$

$$\text{Minimum Cycle Time} = \frac{4.52 \times (105.4 - 105.05)}{17.2/1000 - 0}$$

Minimum Cycle Time = 92.0 seconds

Minimum Cycle Time = 1.53 minutes

## 10 Year Flows

Design Peak Flow = 10.51 L/s

Actual (peak) Flow = 17.2 L/s (from Pump Performance Curve)

Average Flow rate = 65% of design peak flow

Run Time =  $\frac{\text{area of wet well} \times (\text{pump start level} - \text{pump stop level})}{\text{flow rate out} - \text{average flow incoming}}$

Run Time =  $\frac{4.52 \times (105.4 - 105.05)}{17.2/1000 - 0.65 \times 10.51/1000}$

Run Time = 152.58 seconds

Run Time = 2.54 minutes

Fill Time =  $\frac{\text{area of wet well} \times (\text{pump start level} - \text{pump stop level})}{\text{Average flow incoming} - \text{no outgoing flow}}$

Fill Time =  $\frac{4.52 \times (105.4 - 105.05)}{0.65 \times 10.51/1000 - 0}$

Fill Time = 231.57 seconds

Fill Time = 3.86 minutes

Total Cycle Time = Run Time + Fill Time

Total Cycle Time = 2.54 + 3.86

Total Cycle Time = 6.40 minutes

Minimum Cycle Time =  $\frac{\text{area of wet well} \times (\text{pump start level} - \text{pump stop level})}{\text{Flow rate out} - \text{no incoming flow}}$

Minimum Cycle Time =  $\frac{4.52 \times (105.4 - 105.05)}{17.2/1000 - 0}$

Minimum Cycle Time = 92.0 seconds

Minimum Cycle Time = 1.53 minutes

## **20 Year Flows**

Design Peak Flow = 20.64 L/s

Actual (peak) Flow = 17.2 L/s (from Pump Performance Curve)

Average Flow rate = 65% of design peak flow

Run Time =  $\frac{\text{area of wet well} \times (\text{pump start level} - \text{pump stop level})}{\text{flow rate out} - \text{average flow rate incoming}}$

Run Time =  $\frac{4.52 \times (105.4 - 104.72)}{17.2/1000 - 0.65 \times 20.64/1000}$

Run Time = 812.26 seconds

Run Time = 13.54 minutes

Fill Time =  $\frac{\text{area of wet well} \times (\text{pump start level} - \text{pump stop level})}{\text{Average flow incoming} - \text{no outgoing flow}}$

Fill Time =  $\frac{4.52 \times (105.4 - 104.72)}{0.65 \times 20.64/1000 - 0}$

Fill Time = 229.10 seconds

Fill Time = 3.82 minutes

Total Cycle Time = Run Time + Fill Time

Total Cycle Time = 13.54 + 3.82

Total Cycle Time = 17.36 minutes

Minimum Cycle Time =  $\frac{\text{area of wet well} \times (\text{pump start level} - \text{pump stop level})}{\text{Flow rate out} - \text{no incoming flow}}$

Minimum Cycle Time =  $\frac{4.52 \times (105.4 - 104.72)}{17.2/1000 - 0}$

Minimum Cycle Time = 178.70 seconds

Minimum Cycle Time = 2.98 minutes

**APPENDIX C:**

**ELECTRICAL AND STRUCTURAL INFORMATION**

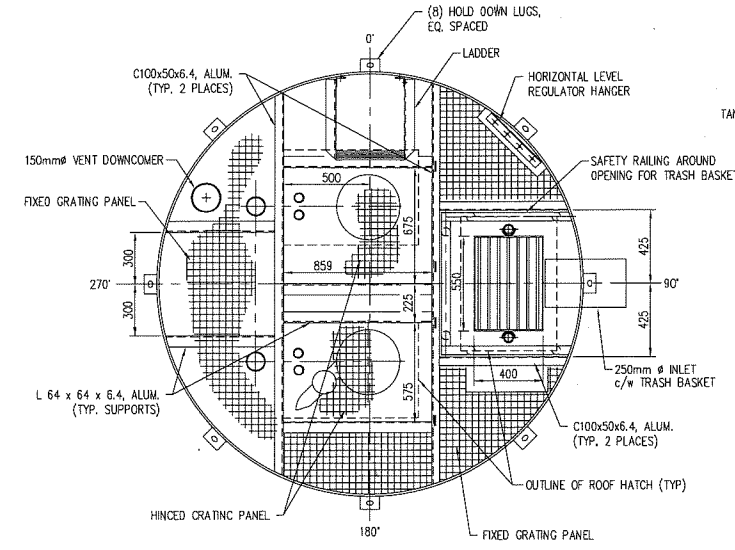
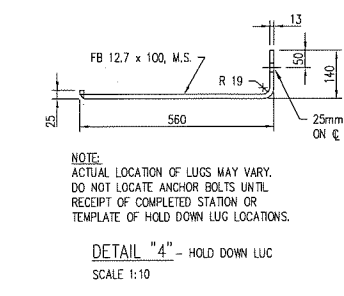
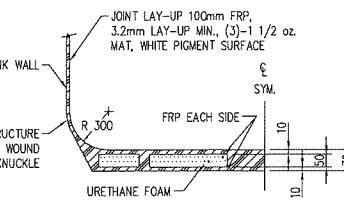
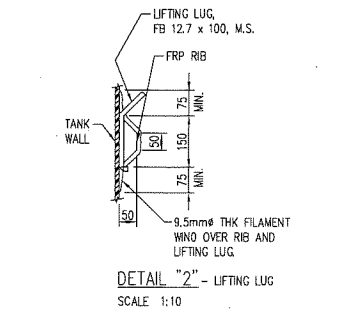
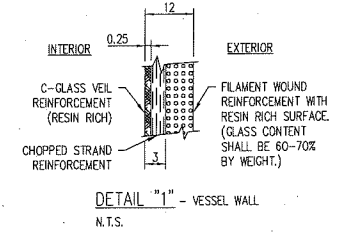
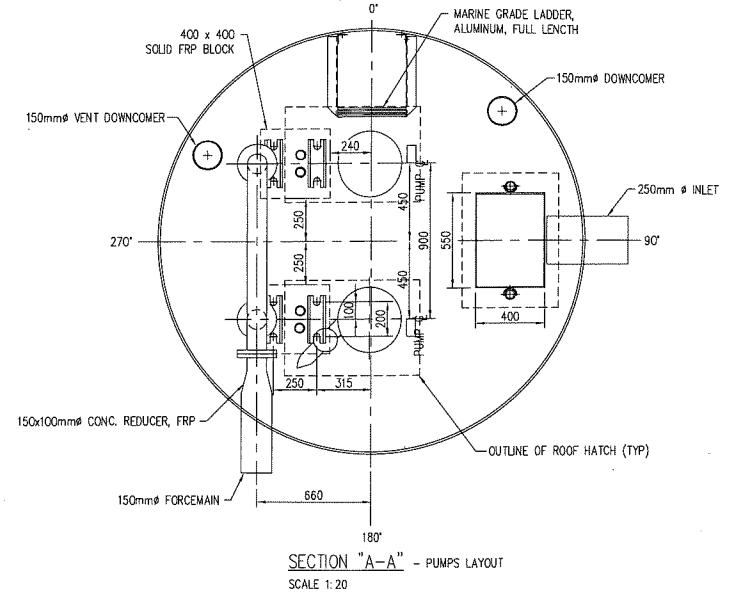
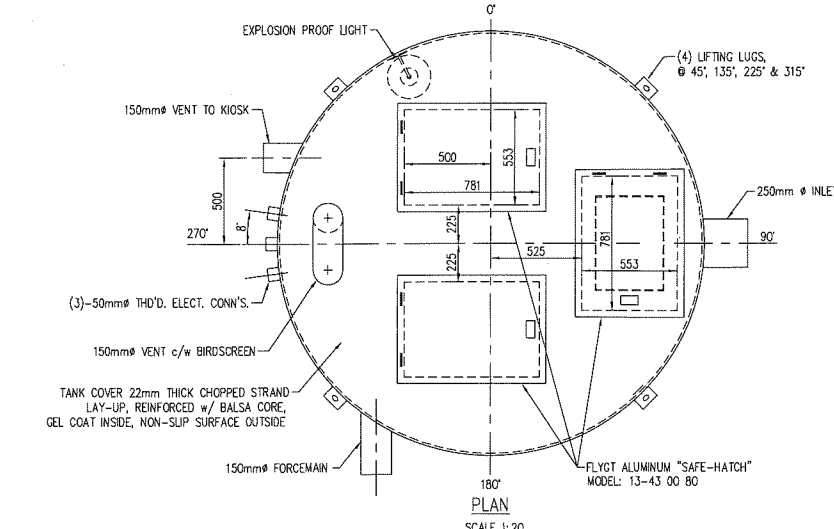

NOTES:  
 1. ALL GRATING PANELS TO BE 38 x 38 x 38 HIGH FRP  
 2. ALL SUPPORTS TO BE ALUMINUM

SECTION "B-B" - PLATFORM LAYOUT SCALE 1:20

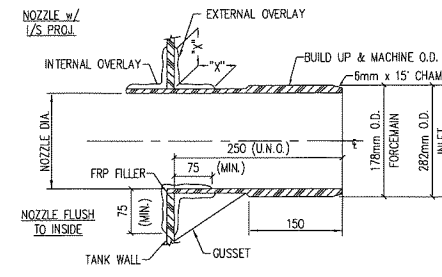

NOZZLE NOTES

A MINIMUM OF 2 LAYERS OF WOVEN ROVING IS REQUIRED FOR NOZZLE PORTION OF OVERLAY. TANK PORTION OF OVERLAY SHALL BE SAME THICKNESS AS TANK WALL. DIMENSION "X" SHALL BE GREATER THAN ONE HALF THE NOZZLE DIAMETER. INTERNAL OVERLAY TO HAVE A MINIMUM OF 2 LAYERS MAT. FRP REINFORCING MATERIAL TO BE CUT TO A SHAPE TO ENSURE A SMOOTH LAMINATE.  
 O.D.'s REPRESENT THICKNESSES REQUIRED FOR ADEQUATE NOZZLE STRENGTH. TO BE CONNECTED TO EXTERIOR PIPING WITH A ROBAR TRANSITION COUPLER OR EQUAL.

DETAIL "5" - TYPICAL NOZZLE, MACHINED N.T.S.

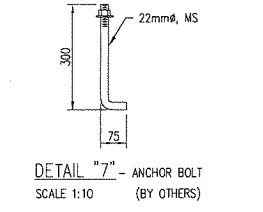

DETAIL "7" - ANCHOR BOLT SCALE 1:10 (BY OTHERS)

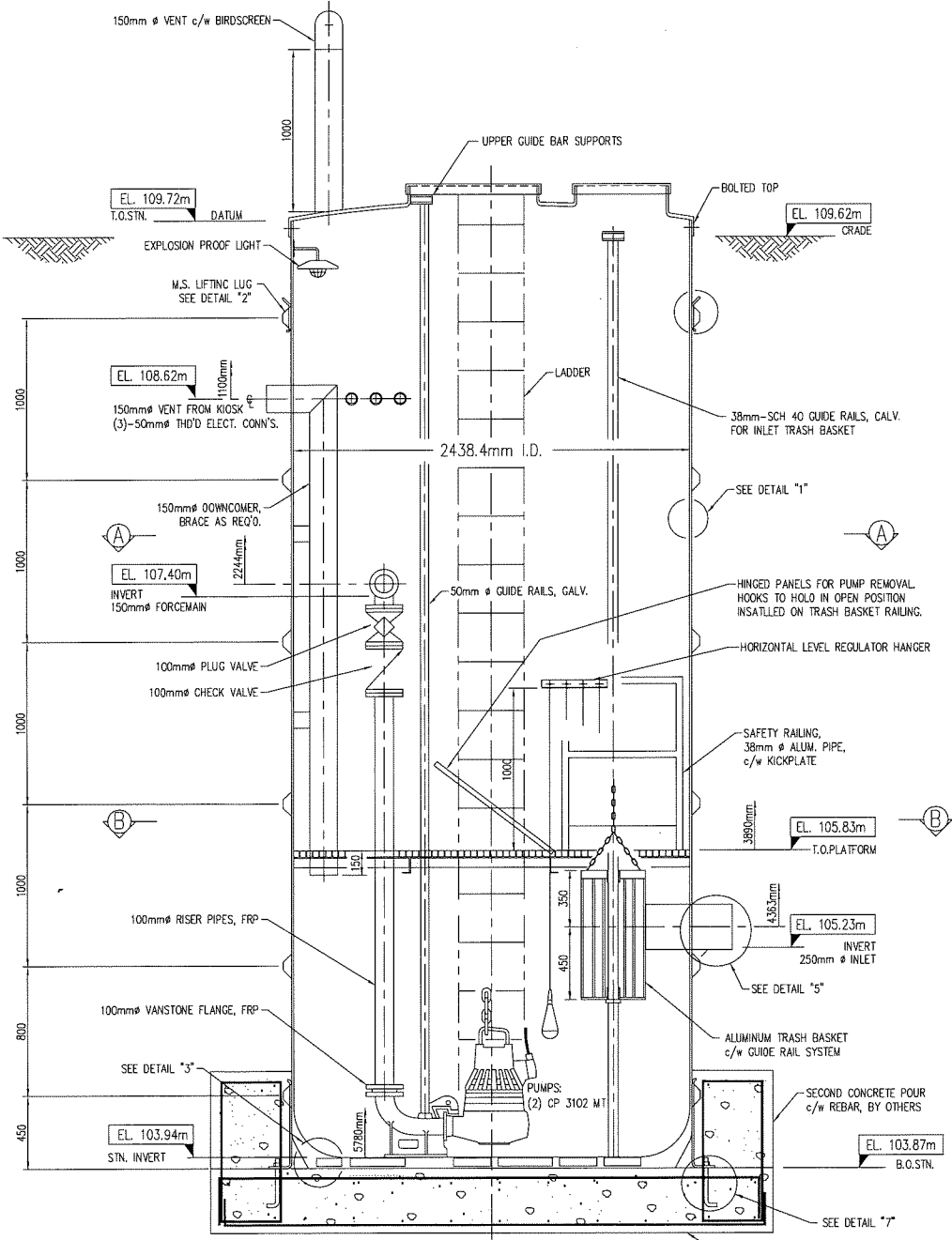

NOTE: CONCRETE SHOWN FOR ILLUSTRATIVE PURPOSES ONLY. FOUNDATION TO BE DESIGNED & SUPPLIED BY OTHERS.

NOTE: SEE PLAN VIEW FOR TRUE ORIENTATION

BILL OF MATERIALS		
ITEM	QTY	DESCRIPTION
1	8	HOLD DOWN LUGS, MS
2	4	LIFTING LUGS, MS
3	3	FLYGT ALUMINUM "SAFE-HATCH" ACCESS FRAMES MODEL 13-43 00 80
4		
5	1	MARINE GRADE SAFETY LADDER, ALUMINUM, FULL LENGTH
6	1	250mm Ø INLET, MACHINED, FRP c/w ALUMINUM TRASH BASKET & GUIDE RAILS
7	1	150mm Ø FORCEMAIN, MACHINED, FRP, c/w (2) 100mm Ø RISER PIPES, FLXVANSTONE (1)-100mm LR 90° ELL, FLXFRP; (1)-100mm STR. IEE, FRP
8	1	150mm Ø VENT, FRP, c/w 180° RET. BEND & BIRDSCREEN
9	1	150mm Ø VENT TO KIOSK, FRP, c/w DOWNCOMER
10	3	50mm TH'D. ELECTRICAL CONNECTIONS
11	8	20mm PUMP BASE BOLTS, 304 SS
12	4	50mm GUIDE BARS, GALV.
13	2	38mm-SCH 40 GUIDE BARS, GALV. (TRASH BASKET)
14	1	EXPLOSION PROOF LIGHT, APPLETON 100 WATT MODEL ABLB 1075
15	1	INTERMEDIATE PLATFORM, FULL DIAMETER c/w ALUMINUM SUPPORT MEMBERS, FRP GRATING PANELS, HINGED HATCHES FOR PUMP REMOVAL, OPENING FOR TRASH BASKET REMOVAL c/w REMOVABLE HAND RAILINGS
16	8	22mm Ø ANCHOR BOLTS, MS (BY OTHERS)
17	2	UPPER GUIDE BAR SUPPORTS (BY FLYGT)
18	2	PUMP CP 3102 MT DN100, c/w DISCHARGE ELBOW (BY FLYGT)
19	2	100mm Ø CHECK VALVE (BY FLYGT)
20	2	100mm Ø PLUG VALVE (BY FLYGT)
21	1	HORIZONTAL LEVEL REGULATOR HANGER (BY FLYGT)

FABRICATION DESIGN STANDARDS

1. FLYGT SPECIFICATION GE-1008-04, REVISION MAY 2002
2. AMEC 45-10.01 MANUFACTURE AND INSTALLATION FOR FRP STRUCTURES
3. AMEC 45-10.02 FRP PRESSURE PIPE, FITTINGS AND FLANGES
4. CANADIAN GOVERNMENT STANDARD 41-CP-22

GENERAL NOTES

1. WINDING ANGLE - 70°
2. TANK WALL - 12mm THICK, (9) COVERS
3. LINER - C-GLASS VEIL AND (2)-1 1/2 oz. MAT
4. RESIN - ASHLAND 1951 ISOPHTHALIC
5. EXTERIOR (ABOVE GRADE) TO HAVE DARK GREEN GELCOAT
6. INTERIOR FINISH: WHITE ISOPHTHALIC NPG GELCOAT
7. DIMENSIONS ARE IN MILLIMETERS U.N.O.

INSTALLATION PROCEDURES

THE FOLLOWING RECOMMENDATIONS ARE BASED ON FLYGT EXPERIENCE AND ARE IN NO WAY MEANT TO REPLACE THE ENGINEERS INSTRUCTIONS OR SPECIFICATIONS AND MUST BE USED IN CONJUNCTION WITH THE EXISTING AND ANTICIPATED CONDITIONS AT THE JOBSITE.

1. USE THE LIFTING LUGS PROVIDED FOR VERTICAL HANDLING.
2. USE SLINGS AROUND THE MAIN TANK FOR HORIZONTAL HANDLING.
3. ENSURE UNIT IS STANDING VERTICAL ON CONCRETE PAD.
4. BOLT UNIT FIRMLY AND SQUARELY IN PLACE, SHIM WHERE NECESSARY.
5. ENCASE BOTTOM RIB IN CONCRETE TO A MINIMUM HEIGHT OF 150mm ABOVE RIB TO PROVIDE ANCHORAGE. REBAR TO CONNECT SECOND POUR TO CONCRETE BASE PAD.
6. WHEN EXTERNAL VALVES ARE MOUNTED, SUPPORT PIPING CONNECTIONS DIRECT TO CONCRETE PAD.
7. MAINTAIN A DRY SITE UNTIL BACKFILLING OPERATIONS COMMENCE.
8. USE A GOOD QUALITY SCREENING OR SAND AS BACKFILL MATERIAL TO 90% COMPACTION.
9. PLACE THE BACKFILL IN EQUAL INCREMENTS NOT EXCEEDING 300mm THICK AROUND THE STATION TO PREVENT UNBALANCED LOADS BEING IMPOSED DURING BACKFILLING OPERATIONS. PROGRESSIVELY TAMP BACKFILL AROUND STATION TO FULL HEIGHT TO REDUCE SETTLEMENT TO AN ABSOLUTE MINIMUM.

REV	DATE	DESCRIPTION	BY
3	2006/02/24	REVISED ROOF ACCESS HATCHES	LMc
2	2005/12/01	PLATFORM RELOCATED	LMc
1	2005/11/29	ELEVATION CHANGES	LMc
0	2005/09/30	ISSUED FOR APPROVAL	LMc

TOLERANCES (U.N.O.)	
LINEAR	ANGULAR
X ± 1.5	XX ± 1/2°

**B** BASKI INDUSTRIES (1985) LTD. 2378 WESTLAKE RD. KELOWNA, B.C. V1Z 2V2

NOTICE: THIS DRAWING HAS NOT BEEN PUBLISHED AND IS THE SOLE PROPERTY OF BASKI INDUSTRIES (1985) LTD. AND IS LOANED TO THE BORROWER FOR HIS CONFIDENTIAL USE ONLY. AND IN CONSIDERATION OF THE LOAN OF THIS DRAWING, THE BORROWER PROMISES AND AGREES TO RETURN IT UPON REQUEST AND AGREES THAT IT SHALL NOT BE REPRODUCED, COPIED, LENT OR OTHERWISE DISPOSED OF DIRECTLY OR INDIRECTLY NOR USED FOR ANY PURPOSE OTHER THAN THAT FOR WHICH IT WAS FURNISHED.

CUSTOMER	ITT FLYGT CANADA	ENGINEER	DAVID McMANUS ENGINEERING LTD. NEPEAN, ONTARIO
PROJECT	RIDEAU CARLETON RACEWAY SEWAGE PUMP STATION		
TITLE	2438.4mm I.D. RIDEAU CARLETON RACEWAY LIFT STATION		
ENG BY:	LMc	DATE:	2005/09/30
APP BY:		SCALE:	AS SHOWN
ISSUED BY:		DRAWING NUMBER:	05-218
		REV	(3)



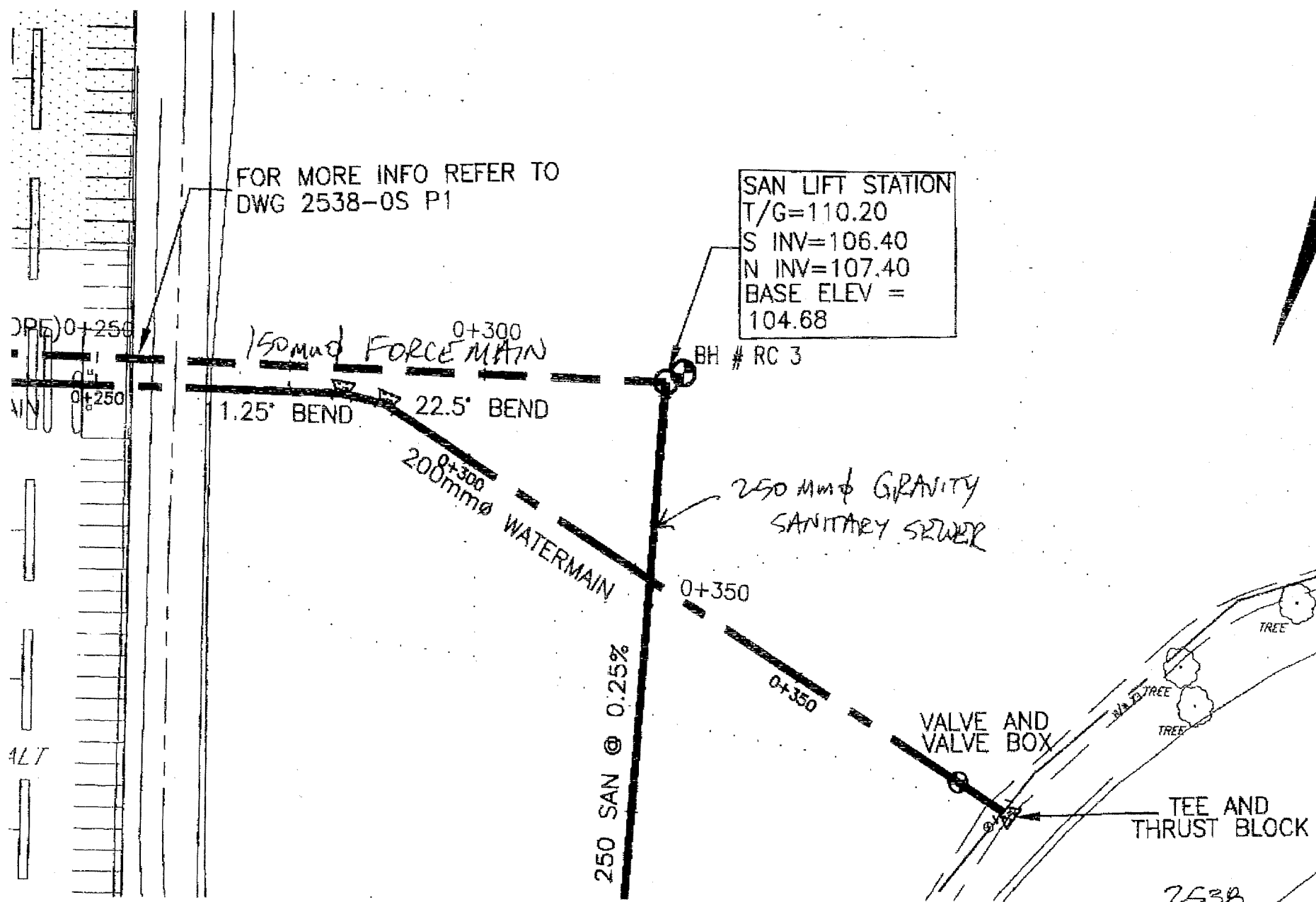

SAN LIFT STATION  
T/G=110.20  
S INV=106.40  
N INV=107.40  
BASE ELEV =  
104.68

2538  
sep 7/05  
NTS

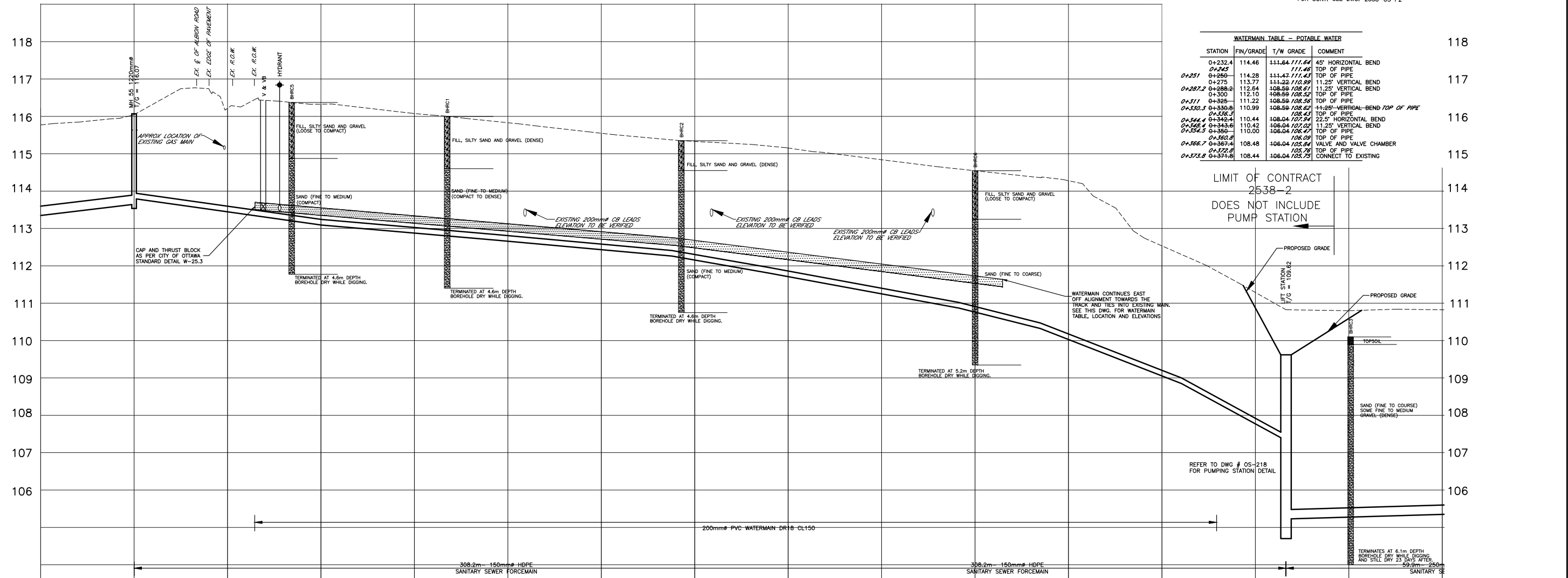
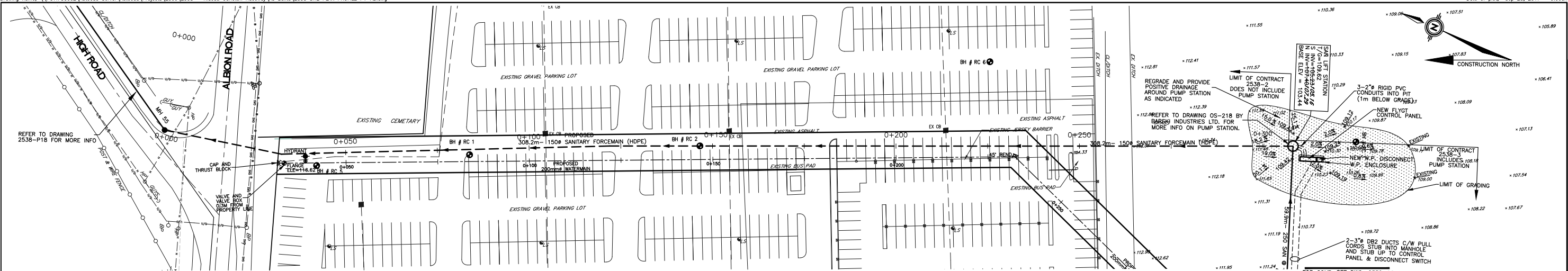

WATERMAIN TABLE - POTABLE WATER			
STATION	FIN/GRADE	T/W GRADE	COMMENT
0+232.4	114.46	111.64 / 111.64	45° HORIZONTAL BEND
0+245		111.46	TOP OF PIPE
0+251	0+250	114.28 / 111.43	TOP OF PIPE
0+275	113.77	111.22 / 110.89	11.25° VERTICAL BEND
0+287.2	0+288.2	112.64 / 108.59	11.25° VERTICAL BEND
0+300	112.10	108.59 / 108.59	TOP OF PIPE
0+311	0+308	111.22	TOP OF PIPE
0+330.5	0+330.8	110.99	11.25° VERTICAL BEND TOP OF PIPE
0+336.5		108.59 / 108.62	TOP OF PIPE
0+344.4	0+342.4	110.44 / 108.04	22.5° HORIZONTAL BEND
0+348.4	0+343.6	110.42	11.25° VERTICAL BEND
0+354.5	0+350	110.00	TOP OF PIPE
0+360.8		108.09	TOP OF PIPE
0+366.7	0+367.4	108.48	VALVE AND VALVE CHAMBER
0+372.8	0+372.8	108.78	TOP OF PIPE
0+373.8	0+371.8	108.44	108.04 / 105.75

LIMIT OF CONTRACT  
2538-2  
DOES NOT INCLUDE  
PUMP STATION

REFER TO DWG # OS-218  
FOR PUMPING STATION DETAIL

STATION	TOP OF WATERMAIN	SANITARY SEWER ELEVATION	EXISTING @ R.O.W. ELEVATION	CHAINAGE
0+000	113.70	112.87	116.27	0+000
0+025	113.66	112.86	116.27	0+025
0+032.3	113.65	112.86	116.40	0+032.3
0+037.8	113.65	112.86	116.40	0+037.8
0+049.0	113.65	112.86	116.40	0+049.0
0+043.7	113.65	112.86	116.40	0+043.7
0+050	113.55	112.86	116.37	0+050
0+075	113.34	112.84	116.08	0+075
0+100	113.13	112.77	115.87	0+100
0+104.6	113.13	112.77	115.87	0+104.6
0+125	112.91	112.69	115.55	0+125
0+147	112.57	112.66	115.37	0+147
0+150	112.57	112.66	115.37	0+150
0+154.5	112.57	112.66	115.37	0+154.5
0+175	112.15	112.15	115.15	0+175
0+200	111.96	111.96	114.84	0+200
0+213.7	111.73	111.67	114.55	0+213.7
0+225	111.64	111.64	114.55	0+225
0+232.4	111.64	111.64	114.55	0+232.4
0+250	111.28	111.28	114.28	0+250
0+275	110.89	110.89	113.77	0+275
0+300	110.59	110.59	111.95	0+300
0+308.2	108.59	108.59	111.22	0+308.2
0+325	110.10	110.10	110.10	0+325
0+350	110.07	110.07	110.07	0+350

NOTE  
THE POSITION OF ALL POLE LINES, CONDUITS, WATERMANS,  
SEWERS AND OTHER UNDERGROUND AND OVERGROUND  
UTILITIES AND STRUCTURES IS NOT NECESSARILY SHOWN  
ON THE CONTRACT DRAWINGS, AND WHERE SHOWN, THE  
ACCURACY OF THE POSITION OF SUCH UTILITIES AND  
STRUCTURES IS NOT GUARANTEED. BEFORE STARTING WORK,  
DETERMINE THE EXACT LOCATION OF ALL SUCH UTILITIES  
AND STRUCTURES AND ASSUME ALL LIABILITY FOR DAMAGE TO THEM.



No.	REVISION	DATE	BY	No.	REVISION	DATE	BY
7.	REVISED SANITARY AND WATERMAIN ALIGNMENT SHIFTED PUMP STATION WEST.	FEB 10/06	CJR				
6.	REVISED WATERMAIN	JAN 16/06	CJR				
5.	SANITARY SEWER REVISED	NOV 24/05	CJR				
4.	ISSUED FOR CONSTRUCTION	NOV 18/05	CJR				
3.	ISSUED FOR TENDER (CONTRACT 2538-2)	OCT 06/05	CJR				
2.	REVISED AND RESUBMITTED TO CITY	OCT 06/05	CJR				
1.	ISSUED TO CITY FOR REVIEW	SEP 12/05	CR				
8.	AS BUILT WATERMAIN	JUL 12/07	JLS				

**DME Ltd.**  
David McManus  
Engineering Ltd.  
400 - 30 Camelot Drive  
Ottawa Ontario, K2G 3X8  
E-mail: mcmanus@dme.on.ca  
Ph. 225-1929 Fax 225-7330

BASEPLAN: DME  
DESIGN: CR  
CHECKED: JLS  
CAD: KJK  
PROJ. MGR: JLS  
APPROVED: JDM

SCALE: HORZ 1:500

PROJECT No. 2538  
SURVEY BY D.M.E.  
DATE APR 2005  
DRAWING No. 2538-OS P1 - AB

**RIDEAU CARLETON RACEWAY  
SANITARY SEWER EXTENSION  
CITY OF OTTAWA**

PLAN AND PROFILE  
RACEWAY PLAN / PROFILE  
STA. 0+000 TO 0+350

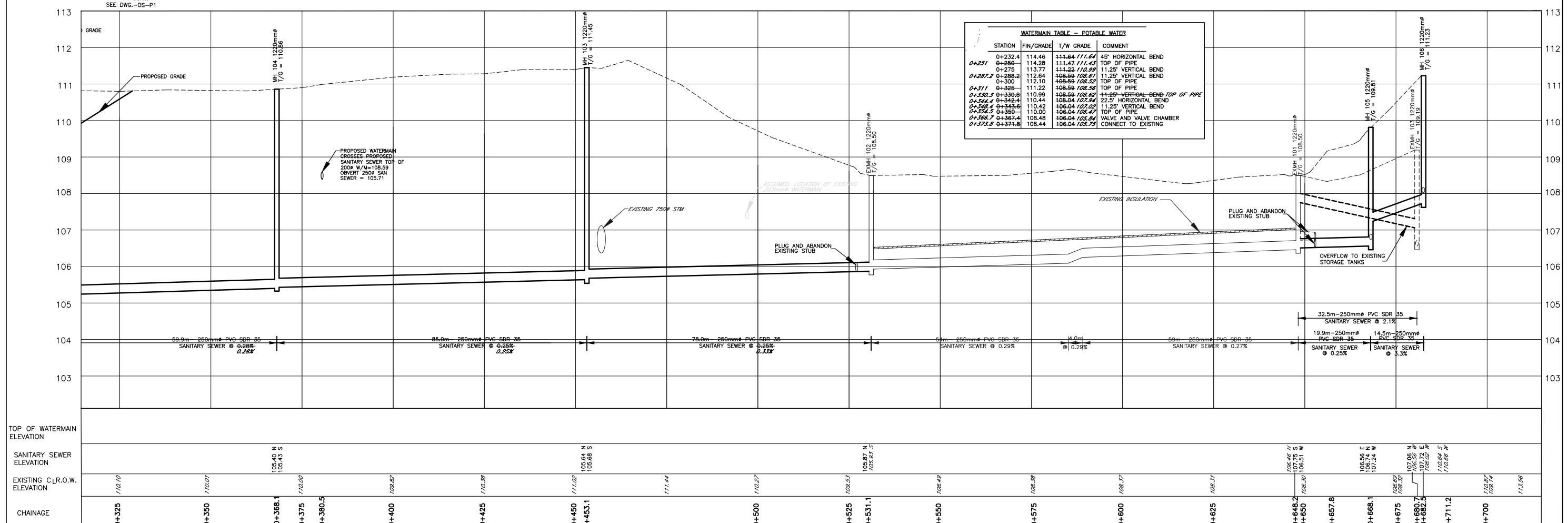
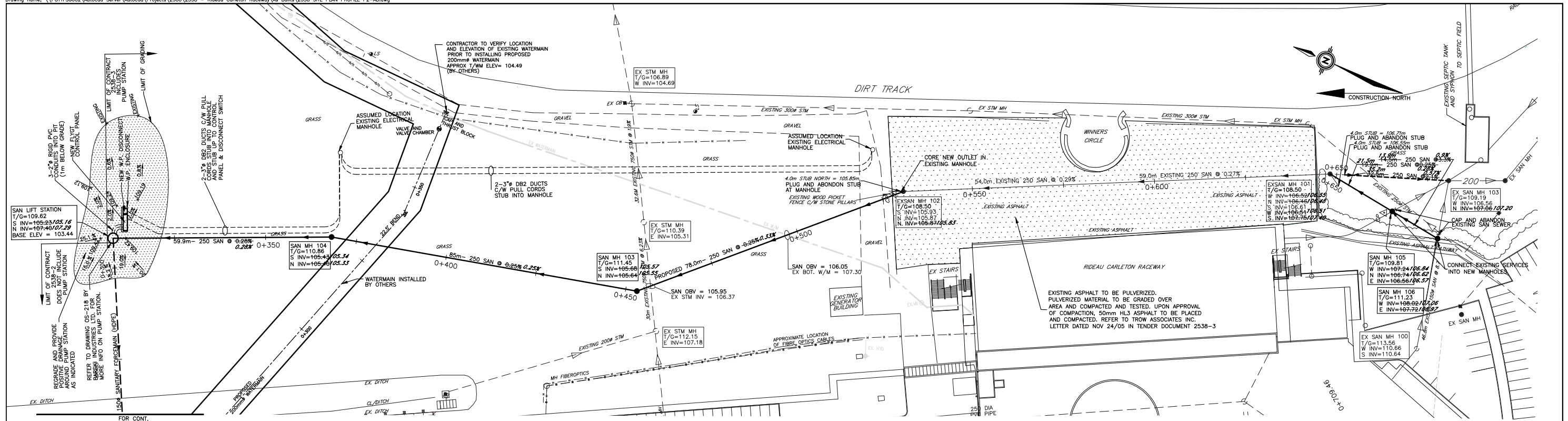

<p>NOTE: THE POSITION OF ALL POLE LINES, CONDUITS, WATERMANS, SEWERS AND OTHER UNDERGROUND AND OVERGROUND UTILITIES AND STRUCTURES IS NOT NECESSARILY SHOWN ON THE CONTRACT DRAWINGS, AND WHERE SHOWN, THE ACCURACY OF THE POSITION OF SUCH UTILITIES AND STRUCTURES IS NOT GUARANTEED. BEFORE STARTING WORK, DETERMINE THE EXACT LOCATION OF ALL SUCH UTILITIES AND STRUCTURES AND ASSUME ALL LIABILITY FOR DAMAGE TO THEM.</p>	<p>AS BUILT</p>	<p>7. ISSUED FOR TENDER (CONTRACT 2538-3) APR 12/06 CJR</p> <p>6. REVISED SANITARY AND WATERMAIN ALIGNMENT SHIFTED PUMP STATION WEST. FEB 10/06 CJR</p> <p>5. SANITARY SEWER REVISED NOV 24/05 CJR</p> <p>4. ELECTRICAL INFO ADDED NOV 01/05 CJR</p> <p>3. ISSUED FOR TENDER (CONTRACT 2538-2) OCT 06/05 CJR</p> <p>2. REVISED AND RESUBMITTED TO CITY OCT 06/05 CJR</p> <p>1. ISSUED TO CITY FOR REVIEW SEP 12/05 CJR</p>	<p>9. AS BUILT INVERTS ADDED OCT 9/07 CJR</p> <p>8. ISSUED FOR CONSTRUCTION (CONTRACT 2538-3) MAY 25/06 CJR</p>	<p>No. REVISION DATE BY No. REVISION DATE BY</p>	<p>BASEPLAN DME</p> <p>DESIGN CR</p> <p>CHECKED JLS</p> <p>CAD KJK</p> <p>PROJ. MGR. JLS</p> <p>APPROVED JDM</p>	<p>SCALE</p> <p>HORIZ 1:500</p> <p>0 5 10 15 20</p>	<p>RIDEAU CARLETON RACEWAY SANITARY SEWER EXTENSION CITY OF OTTAWA</p> <p>PLAN PROFILE RACEWAY PLAN / PROFILE STA. 0+350 TO 0+702.2</p>	<p>PROJECT No. 2538</p> <p>SURVEY BY D.M.E.</p> <p>DATE APR 2005</p> <p>DRAWING No. 2538-OS P2 - AB</p>
--	-----------------	--	---	--	--	---	---	---



PUMP 1

PUMP 2

MAIN DISCONNECT



**DANGER**  
HAULT HIGH VOLTAGE  
**AVERTISSEMENT**  
DÉBRANCHER L'ALIMENTATION  
AVANT D'OUVRIR CETTE PORTE  
**CAUTION**  
DISCONNECT MAIN SUPPLY  
BEFORE OPENING THIS DOOR

FLYDUT  
Mini  
CONTROL  
AND  
STATUS  
II  
24V AC/DC

- LEAKAGE
- TEMPERATURE
- SUPPLY

FLYDUT  
Mini  
CONTROL  
AND  
STATUS  
II  
24V AC/DC

- LEAKAGE
- TEMPERATURE
- SUPPLY

**CAUTION**  
INTRINSIC SECURITY CABLES AND  
NON-INTRINSIC SECURITY CABLES  
MUST NOT SHARE THE SAME CABLE  
CONDUITS (WIRING DUCT)

MILTRONICS

PUMP 1

PUMP 2

SPS  
FEED FROM OLD ELECTRICAL ROOM

PUMP 1 MAN/AUTO selector switch

PUMP 2 MAN/AUTO selector switch

HIGH LEVEL indicator (red)

LOW LEVEL indicator (red)

TEMPERATURE INDICATOR (black)





**Project Name** Rideau Carleton Raceway – Hard Rock Casino

**Report No.**

**Novatech Project No.** 116111

**Inspection Date**

**Owner**

**Inspection Conducted By**

**Veolia**

**General Contractor**

**Comments Verified by Municipality**

Yes  No  N/A

**Report Received**

**Sewer Type**

**Video Type**

**Inspection Reviewed**

Sanitary Sewer

Preliminary Set

**Review Done By** LKC

Storm Sewer

Repair Set

**Review to Contractor**

Combined Sewer

Final Set

DVD No.	Street Name	Start MH No.	End MH No.	(Check Applicable Box)			Inspection Length (m)	Problem/Observation	Comment/Action
				Acceptable	Monitor	Repair			
MHSA-.42 MHSA-.41	EARL ARMSTRONG	.42	.41	<input checked="" type="checkbox"/>	<input type="checkbox"/>	<input type="checkbox"/>	119.00	Moderate Silt, Pile of Gravel @ 35.7m	Requires Cleaning
MHSA-28 MHSA-29	EARL ARMSTRONG	28	29	<input checked="" type="checkbox"/>	<input type="checkbox"/>	<input type="checkbox"/>	72.00	Moderate Grease	Requires Cleaning
MHSA-28A MHSA-28	EARL ARMSTRONG	28A	28	<input checked="" type="checkbox"/>	<input type="checkbox"/>	<input type="checkbox"/>	119.50	Moderate Grease	Requires Cleaning
MHSA-28A NORTH	EARL ARMSTRONG	28A	28A	<input checked="" type="checkbox"/>	<input type="checkbox"/>	<input type="checkbox"/>	2.00	Significant Silt	Requires Cleaning
MHSA-29 MHSA-30	EARL ARMSTRONG	29	30	<input checked="" type="checkbox"/>	<input type="checkbox"/>	<input type="checkbox"/>	0	Significant Gravel, Aborted	Requires Cleaning
MHSA-30 MHSA-29	EARL ARMSTRONG	30	29	<input checked="" type="checkbox"/>	<input type="checkbox"/>	<input type="checkbox"/>	118.00	Significant Grease, Silt, Gravel and Rocks	Requires Cleaning
MHSA-31 MHSA-30	EARL ARMSTRONG	31	30	<input checked="" type="checkbox"/>	<input type="checkbox"/>	<input type="checkbox"/>	118.50	Moderate Grease	Requires Cleaning
MHSA-32 MHSA-31	EARL ARMSTRONG	32	31	<input checked="" type="checkbox"/>	<input type="checkbox"/>	<input type="checkbox"/>	119.50	Moderate Debris @ 61.5m, 99.6m, 103.5m	Requires Cleaning
MHSA-33 MHSA-32	EARL ARMSTRONG	33	32	<input checked="" type="checkbox"/>	<input type="checkbox"/>	<input type="checkbox"/>	118.00		
MHSA-33 MHSA-34	EARL ARMSTRONG	33	34	<input checked="" type="checkbox"/>	<input type="checkbox"/>	<input type="checkbox"/>	119.00	Mild Grease	Requires Cleaning
MHSA-35 MHSA-34	EARL ARMSTRONG	35	34	<input checked="" type="checkbox"/>	<input type="checkbox"/>	<input type="checkbox"/>	52.00		

MHSA-36 MHSA-35	EARL ARMSTRONG	36	35	<input checked="" type="checkbox"/>	<input type="checkbox"/>	<input type="checkbox"/>	118.50		
MHSA-37 MHSA-36	EARL ARMSTRONG	37	36	<input checked="" type="checkbox"/>	<input type="checkbox"/>	<input type="checkbox"/>	119.00		
MHSA-38 MHSA-37	EARL ARMSTRONG	38	37	<input checked="" type="checkbox"/>	<input type="checkbox"/>	<input type="checkbox"/>	118.00		
MHSA-39 MHSA-38	EARL ARMSTRONG	39	38	<input checked="" type="checkbox"/>	<input type="checkbox"/>	<input type="checkbox"/>	118.00	Mild Grease, Debris @ 99.0	Requires Cleaning
MHSA-40 MHSA-39	EARL ARMSTRONG	40	39	<input checked="" type="checkbox"/>	<input type="checkbox"/>	<input type="checkbox"/>	118.50		
MHSA-41 MHSA-40	EARL ARMSTRONG	41	40	<input checked="" type="checkbox"/>	<input type="checkbox"/>	<input type="checkbox"/>	118.50		
MHSA-42 MHSA-41	EARL ARMSTRONG	42	41	<input checked="" type="checkbox"/>	<input type="checkbox"/>	<input type="checkbox"/>	118.00	Moderate Silt	Requires Cleaning
MHSA-42 MHSA-43	EARL ARMSTRONG	42	43	<input checked="" type="checkbox"/>	<input type="checkbox"/>	<input type="checkbox"/>	120.00		
MHSA-43 MHSA-42	EARL ARMSTRONG	43	42	<input checked="" type="checkbox"/>	<input type="checkbox"/>	<input type="checkbox"/>	120.00		
MHSA-44 MHSA-43	EARL ARMSTRONG	44	43	<input checked="" type="checkbox"/>	<input type="checkbox"/>	<input type="checkbox"/>	119.00		
MHSA-44 MHSA-45	EARL ARMSTRONG	44	45	<input checked="" type="checkbox"/>	<input type="checkbox"/>	<input type="checkbox"/>	118.00	Significant Grease, Moderate Silt	Requires Cleaning
MHSA-45A MHSA-44A	EARL ARMSTRONG	45A	44A	<input checked="" type="checkbox"/>	<input type="checkbox"/>	<input type="checkbox"/>	118.50	Mild Grease, Silt	Requires Cleaning
MHSA-46 MHSA-45	EARL ARMSTRONG	46	45	<input checked="" type="checkbox"/>	<input type="checkbox"/>	<input type="checkbox"/>	77.50	Significant Silt, Rocks	Requires Cleaning
MHSA-47 MHSA-46	EARL ARMSTRONG	47	46	<input checked="" type="checkbox"/>	<input type="checkbox"/>	<input type="checkbox"/>	109.00	Moderate Grease and Silt	Requires Cleaning
MHSA-47A MHSA-46A	EARL ARMSTRONG	47A	46A	<input checked="" type="checkbox"/>	<input type="checkbox"/>	<input type="checkbox"/>	109.50	Moderate Grease	Requires Cleaning
MHSA-48 MHSA-47	EARL ARMSTRONG	48	47	<input checked="" type="checkbox"/>	<input type="checkbox"/>	<input type="checkbox"/>	118.00	Moderate Grease	Requires Cleaning
MHSA-49 MHSA-48	EARL ARMSTRONG	49	48	<input checked="" type="checkbox"/>	<input type="checkbox"/>	<input type="checkbox"/>	118.00	Moderate Grease	Requires Cleaning
MHSA-50 MHSA-49	EARL ARMSTRONG	50	49	<input checked="" type="checkbox"/>	<input type="checkbox"/>	<input type="checkbox"/>	119.00		
MHSA-51 MHSA-50	EARL ARMSTRONG	51	50	<input checked="" type="checkbox"/>	<input type="checkbox"/>	<input type="checkbox"/>	119.00		
MHSA-52 MHSA-51	EARL ARMSTRONG	52	51	<input checked="" type="checkbox"/>	<input type="checkbox"/>	<input type="checkbox"/>	118.10		



MHSA-53 MHSA-52	EARL ARMSTRONG	53	52	<input checked="" type="checkbox"/>	<input type="checkbox"/>	<input type="checkbox"/>	118.00	Mild Grease	Requires Cleaning
MHSA-54 MHSA-53	EARL ARMSTRONG	54	43	<input checked="" type="checkbox"/>	<input type="checkbox"/>	<input type="checkbox"/>	95.00	Mild Grease	Requires Cleaning
MHSA-55 MHSA-54	EARL ARMSTRONG	55	54	<input checked="" type="checkbox"/>	<input type="checkbox"/>	<input type="checkbox"/>	118.00		

Navigation controls including a compass, zoom in (+) and zoom out (-) buttons, a street view pegman icon, and a scale bar.

Map style selection buttons: Base Maps (selected), Aerial Maps, and More layers... with Save and Load sub-buttons.

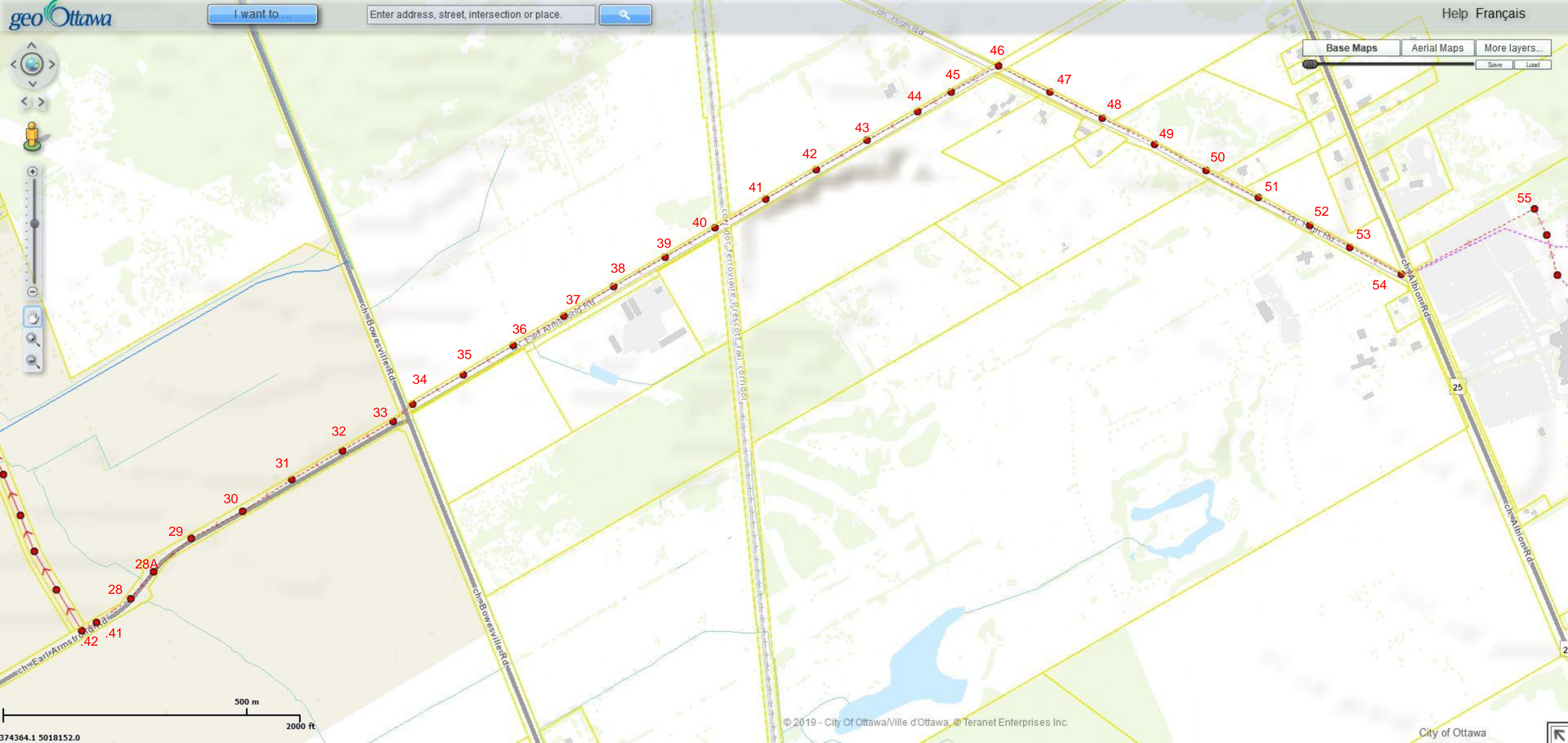

OCTV inspection report  
Hard Rock Ottawa LP  
Sanitary Sewer  
EARL ARMSTRONG, HIGH RD

	Page
1. Index of pipes, sorted by pipe .....	3
2. Index of pipes, sorted by manhole .....	4
3. Index of pipes, sorted by road .....	5
4. Internal condition grade .....	6
5. Operational performance grade .....	7
6. Reinspection with ZOOM .....	8
7. Regular inspection required .....	9
8. Structural condition .....	10
9. Service defects .....	11
10. Construction features .....	13
11. Miscellaneous features .....	15
12. Comments .....	17
13. Survey abandoned .....	18
14. Pipe summary and condition details .....	19

33 items

Pipe	Start/End	Inspection direction	Road	Page
MHSA-.42 MHSA-.41	MHSA-.42 --> MHSA-.41	Direction of flow	EARL ARMSTRONG	<a href="#">19</a>
MHSA-28 MHSA-29	MHSA-28 --> MHSA-29	Against flow	EARL ARMSTRONG	<a href="#">22</a>
MHSA-28A MHSA-28	MHSA-28A --> MHSA-28	Against flow	EARL ARMSTRONG	<a href="#">24</a>
MHSA-28A NORTH	MHSA-28A --> NORTH	Direction of flow	EARL ARMSTRONG	<a href="#">27</a>
MHSA-29 MHSA-30	MHSA-29 --> MHSA-30	Against flow	EARL ARMSTRONG	<a href="#">29</a>
MHSA-30 MHSA-29	MHSA-30 --> MHSA-29	Direction of flow	EARL ARMSTRONG	<a href="#">31</a>
MHSA-31 MHSA-30	MHSA-31 --> MHSA-30	Direction of flow	EARL ARMSTRONG	<a href="#">33</a>
MHSA-32 MHSA-31	MHSA-32 --> MHSA-31	Direction of flow	EARL ARMSTRONG	<a href="#">35</a>
MHSA-33 MHSA-32	MHSA-33 --> MHSA-32	Direction of flow	EARL ARMSTRONG	<a href="#">37</a>
MHSA-33 MHSA-34	MHSA-33 --> MHSA-34	Against flow	EARL ARMSTRONG	<a href="#">39</a>
MHSA-35 MHSA-34	MHSA-35 --> MHSA-34	Direction of flow	EARL ARMSTRONG	<a href="#">41</a>
MHSA-36 MHSA-35	MHSA-36 --> MHSA-35	Direction of flow	EARL ARMSTRONG	<a href="#">43</a>
MHSA-37. MHSA-36.	MHSA-37. --> MHSA-36.	Direction of flow	EARL ARMSTRONG	<a href="#">45</a>
MHSA-38 MHSA-37	MHSA-38 --> MHSA-37	Direction of flow	EARL ARMSTRONG	<a href="#">47</a>
MHSA-39 MHSA-38	MHSA-39 --> MHSA-38	Direction of flow	EARL ARMSTRONG	<a href="#">49</a>
MHSA-40 MHSA-39	MHSA-40 --> MHSA-39	Direction of flow	EARL ARMSTRONG	<a href="#">52</a>
MHSA-41 MHSA-40	MHSA-41 --> MHSA-40	Direction of flow	EARL ARMSTRONG	<a href="#">54</a>
MHSA-42 MHSA-41	MHSA-42 --> MHSA-41	Direction of flow	EARL ARMSTRONG	<a href="#">56</a>
MHSA-42 MHSA-43	MHSA-42 --> MHSA-43	Against flow	EARL ARMSTRONG	<a href="#">58</a>
MHSA-43 MHSA-42	MHSA-43 --> MHSA-42	Direction of flow	EARL ARMSTRONG	<a href="#">60</a>
MHSA-44 MHSA-43	MHSA-44 --> MHSA-43	Direction of flow	EARL ARMSTRONG	<a href="#">62</a>
MHSA-44 MHSA-45	MHSA-44 --> MHSA-45	Against flow	EARL ARMSTRONG	<a href="#">64</a>
MHSA-45... MHSA-44...	MHSA-44... --> MHSA-45...	Direction of flow	EARL ARMSTRONG	<a href="#">66</a>
MHSA-46. MHSA-45.	MHSA-46. --> MHSA-45.	Direction of flow	EARL ARMSTRONG	<a href="#">69</a>
MHSA-47... MHSA-46...	MHSA-47... --> MHSA-46...	Direction of flow	EARL ARMSTRONG	<a href="#">71</a>
MHSA-48 MHSA-47	MHSA-48 --> MHSA-47	Direction of flow	HIGH RD	<a href="#">73</a>
MHSA-49 MHSA-48	MHSA-49 --> MHSA-48	Direction of flow	HIGH RD	<a href="#">75</a>
MHSA-50 MHSA-49	MHSA-50 --> MHSA-49	Direction of flow	HIGH RD	<a href="#">78</a>
MHSA-51... MHSA-50...	MHSA-51... --> MHSA-50...	Direction of flow	HIGH RD	<a href="#">80</a>
MHSA-52.. MHSA-51..	MHSA-52.. --> MHSA-51..	Direction of flow	HIGH RD	<a href="#">82</a>
MHSA-53 MHSA-52	MHSA-53 --> MHSA-52	Direction of flow	HIGH RD	<a href="#">84</a>
MHSA-54 MHSA-53	MHSA-54 --> MHSA-53	Direction of flow	HIGH RD	<a href="#">86</a>
MHSA-55.. MHSA-54..	MHSA-55.. --> MHSA-54..	Direction of flow	HIGH RD	<a href="#">88</a>

33 items

Start/End	Inspection direction	Pipe	Road	Page
MHSA-.42 --> MHSA-.41	Direction of flow	MHSA-.42 MHSA-.41	EARL ARMSTRONG	<a href="#">19</a>
MHSA-28 --> MHSA-29	Against flow	MHSA-28 MHSA-29	EARL ARMSTRONG	<a href="#">22</a>
MHSA-28A --> MHSA-28	Against flow	MHSA-28A MHSA-28	EARL ARMSTRONG	<a href="#">24</a>
MHSA-28A --> NORTH	Direction of flow	MHSA-28A NORTH	EARL ARMSTRONG	<a href="#">27</a>
MHSA-29 --> MHSA-30	Against flow	MHSA-29 MHSA-30	EARL ARMSTRONG	<a href="#">29</a>
MHSA-30 --> MHSA-29	Direction of flow	MHSA-30 MHSA-29	EARL ARMSTRONG	<a href="#">31</a>
MHSA-31 --> MHSA-30	Direction of flow	MHSA-31 MHSA-30	EARL ARMSTRONG	<a href="#">33</a>
MHSA-32 --> MHSA-31	Direction of flow	MHSA-32 MHSA-31	EARL ARMSTRONG	<a href="#">35</a>
MHSA-33 --> MHSA-32	Direction of flow	MHSA-33 MHSA-32	EARL ARMSTRONG	<a href="#">37</a>
MHSA-33 --> MHSA-34	Against flow	MHSA-33 MHSA-34	EARL ARMSTRONG	<a href="#">39</a>
MHSA-35 --> MHSA-34	Direction of flow	MHSA-35 MHSA-34	EARL ARMSTRONG	<a href="#">41</a>
MHSA-36 --> MHSA-35	Direction of flow	MHSA-36 MHSA-35	EARL ARMSTRONG	<a href="#">43</a>
MHSA-37. --> MHSA-36.	Direction of flow	MHSA-37. MHSA-36.	EARL ARMSTRONG	<a href="#">45</a>
MHSA-38 --> MHSA-37	Direction of flow	MHSA-38 MHSA-37	EARL ARMSTRONG	<a href="#">47</a>
MHSA-39 --> MHSA-38	Direction of flow	MHSA-39 MHSA-38	EARL ARMSTRONG	<a href="#">49</a>
MHSA-40 --> MHSA-39	Direction of flow	MHSA-40 MHSA-39	EARL ARMSTRONG	<a href="#">52</a>
MHSA-41 --> MHSA-40	Direction of flow	MHSA-41 MHSA-40	EARL ARMSTRONG	<a href="#">54</a>
MHSA-42 --> MHSA-41	Direction of flow	MHSA-42 MHSA-41	EARL ARMSTRONG	<a href="#">56</a>
MHSA-42 --> MHSA-43	Against flow	MHSA-42 MHSA-43	EARL ARMSTRONG	<a href="#">58</a>
MHSA-43 --> MHSA-42	Direction of flow	MHSA-43 MHSA-42	EARL ARMSTRONG	<a href="#">60</a>
MHSA-44 --> MHSA-43	Direction of flow	MHSA-44 MHSA-43	EARL ARMSTRONG	<a href="#">62</a>
MHSA-44 --> MHSA-45	Against flow	MHSA-44 MHSA-45	EARL ARMSTRONG	<a href="#">64</a>
MHSA-44... --> MHSA-45...	Direction of flow	MHSA-45... MHSA-44...	EARL ARMSTRONG	<a href="#">66</a>
MHSA-46. --> MHSA-45.	Direction of flow	MHSA-46. MHSA-45.	EARL ARMSTRONG	<a href="#">69</a>
MHSA-47... --> MHSA-46...	Direction of flow	MHSA-47... MHSA-46...	EARL ARMSTRONG	<a href="#">71</a>
MHSA-48 --> MHSA-47	Direction of flow	MHSA-48 MHSA-47	HIGH RD	<a href="#">73</a>
MHSA-49 --> MHSA-48	Direction of flow	MHSA-49 MHSA-48	HIGH RD	<a href="#">75</a>
MHSA-50 --> MHSA-49	Direction of flow	MHSA-50 MHSA-49	HIGH RD	<a href="#">78</a>
MHSA-51... --> MHSA-50...	Direction of flow	MHSA-51... MHSA-50...	HIGH RD	<a href="#">80</a>
MHSA-52.. --> MHSA-51..	Direction of flow	MHSA-52.. MHSA-51..	HIGH RD	<a href="#">82</a>
MHSA-53 --> MHSA-52	Direction of flow	MHSA-53 MHSA-52	HIGH RD	<a href="#">84</a>
MHSA-54 --> MHSA-53	Direction of flow	MHSA-54 MHSA-53	HIGH RD	<a href="#">86</a>
MHSA-55.. --> MHSA-54..	Direction of flow	MHSA-55.. MHSA-54..	HIGH RD	<a href="#">88</a>

33 items

Road	Pipe	Start/End	Inspection direction	Page
EARL ARMSTRONG	MHSA-.42 MHSA-.41	MHSA-.42 --> MHSA-.41	Direction of flow	<a href="#">19</a>
EARL ARMSTRONG	MHSA-28 MHSA-29	MHSA-28 --> MHSA-29	Against flow	<a href="#">22</a>
EARL ARMSTRONG	MHSA-28A MHSA-28	MHSA-28A --> MHSA-28	Against flow	<a href="#">24</a>
EARL ARMSTRONG	MHSA-28A NORTH	MHSA-28A --> NORTH	Direction of flow	<a href="#">27</a>
EARL ARMSTRONG	MHSA-29 MHSA-30	MHSA-29 --> MHSA-30	Against flow	<a href="#">29</a>
EARL ARMSTRONG	MHSA-30 MHSA-29	MHSA-30 --> MHSA-29	Direction of flow	<a href="#">31</a>
EARL ARMSTRONG	MHSA-31 MHSA-30	MHSA-31 --> MHSA-30	Direction of flow	<a href="#">33</a>
EARL ARMSTRONG	MHSA-32 MHSA-31	MHSA-32 --> MHSA-31	Direction of flow	<a href="#">35</a>
EARL ARMSTRONG	MHSA-33 MHSA-32	MHSA-33 --> MHSA-32	Direction of flow	<a href="#">37</a>
EARL ARMSTRONG	MHSA-33 MHSA-34	MHSA-33 --> MHSA-34	Against flow	<a href="#">39</a>
EARL ARMSTRONG	MHSA-35 MHSA-34	MHSA-35 --> MHSA-34	Direction of flow	<a href="#">41</a>
EARL ARMSTRONG	MHSA-36 MHSA-35	MHSA-36 --> MHSA-35	Direction of flow	<a href="#">43</a>
EARL ARMSTRONG	MHSA-37. MHSA-36.	MHSA-37. --> MHSA-36.	Direction of flow	<a href="#">45</a>
EARL ARMSTRONG	MHSA-38 MHSA-37	MHSA-38 --> MHSA-37	Direction of flow	<a href="#">47</a>
EARL ARMSTRONG	MHSA-39 MHSA-38	MHSA-39 --> MHSA-38	Direction of flow	<a href="#">49</a>
EARL ARMSTRONG	MHSA-40 MHSA-39	MHSA-40 --> MHSA-39	Direction of flow	<a href="#">52</a>
EARL ARMSTRONG	MHSA-41 MHSA-40	MHSA-41 --> MHSA-40	Direction of flow	<a href="#">54</a>
EARL ARMSTRONG	MHSA-42 MHSA-41	MHSA-42 --> MHSA-41	Direction of flow	<a href="#">56</a>
EARL ARMSTRONG	MHSA-42 MHSA-43	MHSA-42 --> MHSA-43	Against flow	<a href="#">58</a>
EARL ARMSTRONG	MHSA-43 MHSA-42	MHSA-43 --> MHSA-42	Direction of flow	<a href="#">60</a>
EARL ARMSTRONG	MHSA-44 MHSA-43	MHSA-44 --> MHSA-43	Direction of flow	<a href="#">62</a>
EARL ARMSTRONG	MHSA-44 MHSA-45	MHSA-44 --> MHSA-45	Against flow	<a href="#">64</a>
EARL ARMSTRONG	MHSA-45... MHSA-44...	MHSA-44... --> MHSA-45...	Direction of flow	<a href="#">66</a>
EARL ARMSTRONG	MHSA-46. MHSA-45.	MHSA-46. --> MHSA-45.	Direction of flow	<a href="#">69</a>
EARL ARMSTRONG	MHSA-47... MHSA-46...	MHSA-47... --> MHSA-46...	Direction of flow	<a href="#">71</a>
HIGH RD	MHSA-48 MHSA-47	MHSA-48 --> MHSA-47	Direction of flow	<a href="#">73</a>
HIGH RD	MHSA-49 MHSA-48	MHSA-49 --> MHSA-48	Direction of flow	<a href="#">75</a>
HIGH RD	MHSA-50 MHSA-49	MHSA-50 --> MHSA-49	Direction of flow	<a href="#">78</a>
HIGH RD	MHSA-51... MHSA-50...	MHSA-51... --> MHSA-50...	Direction of flow	<a href="#">80</a>
HIGH RD	MHSA-52.. MHSA-51..	MHSA-52.. --> MHSA-51..	Direction of flow	<a href="#">82</a>
HIGH RD	MHSA-53 MHSA-52	MHSA-53 --> MHSA-52	Direction of flow	<a href="#">84</a>
HIGH RD	MHSA-54 MHSA-53	MHSA-54 --> MHSA-53	Direction of flow	<a href="#">86</a>
HIGH RD	MHSA-55.. MHSA-54..	MHSA-55.. --> MHSA-54..	Direction of flow	<a href="#">88</a>

33 items

1 - Acceptable structural condition (33 of 33 items)

Total	Peak	Pipe	Start/End	Direction	Road	Page
0	0	MHSA-.42 MHSA-.41	MHSA-.42 --> MHSA-.41	Direction of flow	EARL ARMSTRONG	<a href="#">19</a>
0	0	MHSA-28 MHSA-29	MHSA-28 --> MHSA-29	Against flow	EARL ARMSTRONG	<a href="#">22</a>
0	0	MHSA-28A MHSA-28	MHSA-28A --> MHSA-28	Against flow	EARL ARMSTRONG	<a href="#">24</a>
0	0	MHSA-28A NORTH	MHSA-28A --> NORTH	Direction of flow	EARL ARMSTRONG	<a href="#">27</a>
0	0	MHSA-29 MHSA-30	MHSA-29 --> MHSA-30	Against flow	EARL ARMSTRONG	<a href="#">29</a>
0	0	MHSA-30 MHSA-29	MHSA-30 --> MHSA-29	Direction of flow	EARL ARMSTRONG	<a href="#">31</a>
0	0	MHSA-31 MHSA-30	MHSA-31 --> MHSA-30	Direction of flow	EARL ARMSTRONG	<a href="#">33</a>
0	0	MHSA-32 MHSA-31	MHSA-32 --> MHSA-31	Direction of flow	EARL ARMSTRONG	<a href="#">35</a>
0	0	MHSA-33 MHSA-32	MHSA-33 --> MHSA-32	Direction of flow	EARL ARMSTRONG	<a href="#">37</a>
0	0	MHSA-33 MHSA-34	MHSA-33 --> MHSA-34	Against flow	EARL ARMSTRONG	<a href="#">39</a>
0	0	MHSA-35 MHSA-34	MHSA-35 --> MHSA-34	Direction of flow	EARL ARMSTRONG	<a href="#">41</a>
0	0	MHSA-36 MHSA-35	MHSA-36 --> MHSA-35	Direction of flow	EARL ARMSTRONG	<a href="#">43</a>
0	0	MHSA-37. MHSA-36.	MHSA-37. --> MHSA-36.	Direction of flow	EARL ARMSTRONG	<a href="#">45</a>
0	0	MHSA-38 MHSA-37	MHSA-38 --> MHSA-37	Direction of flow	EARL ARMSTRONG	<a href="#">47</a>
0	0	MHSA-39 MHSA-38	MHSA-39 --> MHSA-38	Direction of flow	EARL ARMSTRONG	<a href="#">49</a>
0	0	MHSA-40 MHSA-39	MHSA-40 --> MHSA-39	Direction of flow	EARL ARMSTRONG	<a href="#">52</a>
0	0	MHSA-41 MHSA-40	MHSA-41 --> MHSA-40	Direction of flow	EARL ARMSTRONG	<a href="#">54</a>
0	0	MHSA-42 MHSA-41	MHSA-42 --> MHSA-41	Direction of flow	EARL ARMSTRONG	<a href="#">56</a>
0	0	MHSA-42 MHSA-43	MHSA-42 --> MHSA-43	Against flow	EARL ARMSTRONG	<a href="#">58</a>
0	0	MHSA-43 MHSA-42	MHSA-43 --> MHSA-42	Direction of flow	EARL ARMSTRONG	<a href="#">60</a>
0	0	MHSA-44 MHSA-43	MHSA-44 --> MHSA-43	Direction of flow	EARL ARMSTRONG	<a href="#">62</a>
0	0	MHSA-44 MHSA-45	MHSA-44 --> MHSA-45	Against flow	EARL ARMSTRONG	<a href="#">64</a>
0	0	MHSA-45... MHSA-44...	MHSA-44... --> MHSA-45...	Direction of flow	EARL ARMSTRONG	<a href="#">66</a>
0	0	MHSA-46. MHSA-45.	MHSA-46. --> MHSA-45.	Direction of flow	EARL ARMSTRONG	<a href="#">69</a>
0	0	MHSA-47... MHSA-46...	MHSA-47... --> MHSA-46...	Direction of flow	EARL ARMSTRONG	<a href="#">71</a>
0	0	MHSA-48 MHSA-47	MHSA-48 --> MHSA-47	Direction of flow	HIGH RD	<a href="#">73</a>
0	0	MHSA-49 MHSA-48	MHSA-49 --> MHSA-48	Direction of flow	HIGH RD	<a href="#">75</a>
0	0	MHSA-50 MHSA-49	MHSA-50 --> MHSA-49	Direction of flow	HIGH RD	<a href="#">78</a>
0	0	MHSA-51... MHSA-50...	MHSA-51... --> MHSA-50...	Direction of flow	HIGH RD	<a href="#">80</a>
0	0	MHSA-52.. MHSA-51..	MHSA-52.. --> MHSA-51..	Direction of flow	HIGH RD	<a href="#">82</a>
0	0	MHSA-53 MHSA-52	MHSA-53 --> MHSA-52	Direction of flow	HIGH RD	<a href="#">84</a>
0	0	MHSA-54 MHSA-53	MHSA-54 --> MHSA-53	Direction of flow	HIGH RD	<a href="#">86</a>
0	0	MHSA-55.. MHSA-54..	MHSA-55.. --> MHSA-54..	Direction of flow	HIGH RD	<a href="#">88</a>



33 items

**Grade: 3 (20 of 33 items)**

Total	Peak	ICG	Pipe	Start/End	Direction	Road	Page
12	2	1	MHSA-39 MHSA-38	MHSA-39 --> MHSA-38	Direction of flow	EARL ARMSTRONG	<a href="#">49</a>
8	2	1	MHSA-30 MHSA-29	MHSA-30 --> MHSA-29	Direction of flow	EARL ARMSTRONG	<a href="#">31</a>
8	2	1	MHSA-45... MHSA-44...	MHSA-44... --> MHSA-45...	Direction of flow	EARL ARMSTRONG	<a href="#">66</a>
7	2	1	MHSA-.42 MHSA-.41	MHSA-.42 --> MHSA-.41	Direction of flow	EARL ARMSTRONG	<a href="#">19</a>
4	2	1	MHSA-28 MHSA-29	MHSA-28 --> MHSA-29	Against flow	EARL ARMSTRONG	<a href="#">22</a>
4	2	1	MHSA-28A MHSA-28	MHSA-28A --> MHSA-28	Against flow	EARL ARMSTRONG	<a href="#">24</a>
4	2	1	MHSA-29 MHSA-30	MHSA-29 --> MHSA-30	Against flow	EARL ARMSTRONG	<a href="#">29</a>
4	2	1	MHSA-31 MHSA-30	MHSA-31 --> MHSA-30	Direction of flow	EARL ARMSTRONG	<a href="#">33</a>
4	2	1	MHSA-44 MHSA-45	MHSA-44 --> MHSA-45	Against flow	EARL ARMSTRONG	<a href="#">64</a>
4	2	1	MHSA-47... MHSA-46...	MHSA-47... --> MHSA-46...	Direction of flow	EARL ARMSTRONG	<a href="#">71</a>
4	2	1	MHSA-48 MHSA-47	MHSA-48 --> MHSA-47	Direction of flow	HIGH RD	<a href="#">73</a>
4	2	1	MHSA-49 MHSA-48	MHSA-49 --> MHSA-48	Direction of flow	HIGH RD	<a href="#">75</a>
4	2	1	MHSA-53 MHSA-52	MHSA-53 --> MHSA-52	Direction of flow	HIGH RD	<a href="#">84</a>
2	2	1	MHSA-28A NORTH	MHSA-28A --> NORTH	Direction of flow	EARL ARMSTRONG	<a href="#">27</a>
2	2	1	MHSA-32 MHSA-31	MHSA-32 --> MHSA-31	Direction of flow	EARL ARMSTRONG	<a href="#">35</a>
2	2	1	MHSA-33 MHSA-34	MHSA-33 --> MHSA-34	Against flow	EARL ARMSTRONG	<a href="#">39</a>
2	2	1	MHSA-42 MHSA-41	MHSA-42 --> MHSA-41	Direction of flow	EARL ARMSTRONG	<a href="#">56</a>
2	2	1	MHSA-44 MHSA-43	MHSA-44 --> MHSA-43	Direction of flow	EARL ARMSTRONG	<a href="#">62</a>
2	2	1	MHSA-46. MHSA-45.	MHSA-46. --> MHSA-45.	Direction of flow	EARL ARMSTRONG	<a href="#">69</a>
2	2	1	MHSA-54 MHSA-53	MHSA-54 --> MHSA-53	Direction of flow	HIGH RD	<a href="#">86</a>

**Grade: 1 (13 of 33 items)**

Total	Peak	ICG	Pipe	Start/End	Direction	Road	Page
0	0	1	MHSA-33 MHSA-32	MHSA-33 --> MHSA-32	Direction of flow	EARL ARMSTRONG	<a href="#">37</a>
0	0	1	MHSA-35 MHSA-34	MHSA-35 --> MHSA-34	Direction of flow	EARL ARMSTRONG	<a href="#">41</a>
0	0	1	MHSA-36 MHSA-35	MHSA-36 --> MHSA-35	Direction of flow	EARL ARMSTRONG	<a href="#">43</a>
0	0	1	MHSA-37. MHSA-36.	MHSA-37. --> MHSA-36.	Direction of flow	EARL ARMSTRONG	<a href="#">45</a>
0	0	1	MHSA-38 MHSA-37	MHSA-38 --> MHSA-37	Direction of flow	EARL ARMSTRONG	<a href="#">47</a>
0	0	1	MHSA-40 MHSA-39	MHSA-40 --> MHSA-39	Direction of flow	EARL ARMSTRONG	<a href="#">52</a>
0	0	1	MHSA-41 MHSA-40	MHSA-41 --> MHSA-40	Direction of flow	EARL ARMSTRONG	<a href="#">54</a>
0	0	1	MHSA-42 MHSA-43	MHSA-42 --> MHSA-43	Against flow	EARL ARMSTRONG	<a href="#">58</a>
0	0	1	MHSA-43 MHSA-42	MHSA-43 --> MHSA-42	Direction of flow	EARL ARMSTRONG	<a href="#">60</a>
0	0	1	MHSA-50 MHSA-49	MHSA-50 --> MHSA-49	Direction of flow	HIGH RD	<a href="#">78</a>
0	0	1	MHSA-51... MHSA-50...	MHSA-51... --> MHSA-50...	Direction of flow	HIGH RD	<a href="#">80</a>
0	0	1	MHSA-52.. MHSA-51..	MHSA-52.. --> MHSA-51..	Direction of flow	HIGH RD	<a href="#">82</a>
0	0	1	MHSA-55.. MHSA-54..	MHSA-55.. --> MHSA-54..	Direction of flow	HIGH RD	<a href="#">88</a>







80 items

DE - Debris (non-silt / grease) (1 of 80 items)

%	Qty	OPG	ICG	Pipe	Start/End	Direction	Road	Picture	Page
5	1	3	1	MHSA-39 MHSA-38	MHSA-39 --> MHSA-38	Direction of flow	EARL ARMSTRONG	<a href="#">50</a>	<a href="#">49</a>

DEG - Debris grease (33 of 80 items)

%	Qty	OPG	ICG	Pipe	Start/End	Direction	Road	Picture	Page
15	1	3	1	MHSA-39 MHSA-38	MHSA-39 --> MHSA-38	Direction of flow	EARL ARMSTRONG	<a href="#">51</a>	<a href="#">49</a>
5	1	3	1	MHSA-.42 MHSA-.41	MHSA-.42 --> MHSA-.41	Direction of flow	EARL ARMSTRONG	<a href="#">20</a>	<a href="#">19</a>
5	1	3	1	MHSA-28 MHSA-29	MHSA-28 --> MHSA-29	Against flow	EARL ARMSTRONG	<a href="#">23</a>	<a href="#">22</a>
5	1	3	1	MHSA-28 MHSA-29	MHSA-28 --> MHSA-29	Against flow	EARL ARMSTRONG	<a href="#">23</a>	<a href="#">22</a>
5	1	3	1	MHSA-28A MHSA-28	MHSA-28A --> MHSA-28	Against flow	EARL ARMSTRONG	<a href="#">25</a>	<a href="#">24</a>
5	1	3	1	MHSA-28A MHSA-28	MHSA-28A --> MHSA-28	Against flow	EARL ARMSTRONG	<a href="#">25</a>	<a href="#">24</a>
5	1	3	1	MHSA-29 MHSA-30	MHSA-29 --> MHSA-30	Against flow	EARL ARMSTRONG	<a href="#">30</a>	<a href="#">29</a>
5	1	3	1	MHSA-30 MHSA-29	MHSA-30 --> MHSA-29	Direction of flow	EARL ARMSTRONG	<a href="#">32</a>	<a href="#">31</a>
5	1	3	1	MHSA-30 MHSA-29	MHSA-30 --> MHSA-29	Direction of flow	EARL ARMSTRONG	<a href="#">32</a>	<a href="#">31</a>
5	1	3	1	MHSA-31 MHSA-30	MHSA-31 --> MHSA-30	Direction of flow	EARL ARMSTRONG	<a href="#">34</a>	<a href="#">33</a>
5	1	3	1	MHSA-31 MHSA-30	MHSA-31 --> MHSA-30	Direction of flow	EARL ARMSTRONG	<a href="#">34</a>	<a href="#">33</a>
5	1	3	1	MHSA-32 MHSA-31	MHSA-32 --> MHSA-31	Direction of flow	EARL ARMSTRONG	<a href="#">36</a>	<a href="#">35</a>
5	1	3	1	MHSA-33 MHSA-34	MHSA-33 --> MHSA-34	Against flow	EARL ARMSTRONG	<a href="#">40</a>	<a href="#">39</a>
5	1	3	1	MHSA-39 MHSA-38	MHSA-39 --> MHSA-38	Direction of flow	EARL ARMSTRONG	<a href="#">50</a>	<a href="#">49</a>
5	1	3	1	MHSA-39 MHSA-38	MHSA-39 --> MHSA-38	Direction of flow	EARL ARMSTRONG	<a href="#">50</a>	<a href="#">49</a>
5	1	3	1	MHSA-39 MHSA-38	MHSA-39 --> MHSA-38	Direction of flow	EARL ARMSTRONG	<a href="#">50</a>	<a href="#">49</a>
5	1	3	1	MHSA-44 MHSA-43	MHSA-44 --> MHSA-43	Direction of flow	EARL ARMSTRONG	<a href="#">63</a>	<a href="#">62</a>
5	1	3	1	MHSA-44 MHSA-45	MHSA-44 --> MHSA-45	Against flow	EARL ARMSTRONG	<a href="#">65</a>	<a href="#">64</a>
5	1	3	1	MHSA-45... MHSA-44...	MHSA-44... --> MHSA-45...	Direction of flow	EARL ARMSTRONG	<a href="#">67</a>	<a href="#">66</a>
5	1	3	1	MHSA-45... MHSA-44...	MHSA-44... --> MHSA-45...	Direction of flow	EARL ARMSTRONG	<a href="#">67</a>	<a href="#">66</a>
5	1	3	1	MHSA-45... MHSA-44...	MHSA-44... --> MHSA-45...	Direction of flow	EARL ARMSTRONG	<a href="#">67</a>	<a href="#">66</a>
5	1	3	1	MHSA-45... MHSA-44...	MHSA-44... --> MHSA-45...	Direction of flow	EARL ARMSTRONG	<a href="#">68</a>	<a href="#">66</a>
5	1	3	1	MHSA-47... MHSA-46...	MHSA-47... --> MHSA-46...	Direction of flow	EARL ARMSTRONG	<a href="#">72</a>	<a href="#">71</a>
5	1	3	1	MHSA-47... MHSA-46...	MHSA-47... --> MHSA-46...	Direction of flow	EARL ARMSTRONG	<a href="#">72</a>	<a href="#">71</a>
5	1	3	1	MHSA-48 MHSA-47	MHSA-48 --> MHSA-47	Direction of flow	HIGH RD	<a href="#">74</a>	<a href="#">73</a>
5	1	3	1	MHSA-48 MHSA-47	MHSA-48 --> MHSA-47	Direction of flow	HIGH RD	<a href="#">74</a>	<a href="#">73</a>
5	1	3	1	MHSA-49 MHSA-48	MHSA-49 --> MHSA-48	Direction of flow	HIGH RD	<a href="#">76</a>	<a href="#">75</a>
5	1	3	1	MHSA-49 MHSA-48	MHSA-49 --> MHSA-48	Direction of flow	HIGH RD	<a href="#">76</a>	<a href="#">75</a>
5	1	3	1	MHSA-53 MHSA-52	MHSA-53 --> MHSA-52	Direction of flow	HIGH RD	<a href="#">85</a>	<a href="#">84</a>
5	1	3	1	MHSA-53 MHSA-52	MHSA-53 --> MHSA-52	Direction of flow	HIGH RD	<a href="#">85</a>	<a href="#">84</a>
5	1	3	1	MHSA-54 MHSA-53	MHSA-54 --> MHSA-53	Direction of flow	HIGH RD	<a href="#">87</a>	<a href="#">86</a>
0	1	3	1	MHSA-39 MHSA-38	MHSA-39 --> MHSA-38	Direction of flow	EARL ARMSTRONG		<a href="#">49</a>
0	1	3	1	MHSA-39 MHSA-38	MHSA-39 --> MHSA-38	Direction of flow	EARL ARMSTRONG	<a href="#">51</a>	<a href="#">49</a>

DES - Debris silt (9 of 80 items)

%	Qty	OPG	ICG	Pipe	Start/End	Direction	Road	Picture	Page
15	1	3	1	MHSA-30 MHSA-29	MHSA-30 --> MHSA-29	Direction of flow	EARL ARMSTRONG	<a href="#">32</a>	<a href="#">31</a>
10	1	3	1	MHSA-.42 MHSA-.41	MHSA-.42 --> MHSA-.41	Direction of flow	EARL ARMSTRONG	<a href="#">20</a>	<a href="#">19</a>
10	1	3	1	MHSA-28A NORTH	MHSA-28A --> NORTH	Direction of flow	EARL ARMSTRONG	<a href="#">28</a>	<a href="#">27</a>
5	1	3	1	MHSA-.42 MHSA-.41	MHSA-.42 --> MHSA-.41	Direction of flow	EARL ARMSTRONG	<a href="#">20</a>	<a href="#">19</a>
5	1	3	1	MHSA-29 MHSA-30	MHSA-29 --> MHSA-30	Against flow	EARL ARMSTRONG	<a href="#">30</a>	<a href="#">29</a>
5	1	3	1	MHSA-30 MHSA-29	MHSA-30 --> MHSA-29	Direction of flow	EARL ARMSTRONG	<a href="#">32</a>	<a href="#">31</a>
5	1	3	1	MHSA-44 MHSA-45	MHSA-44 --> MHSA-45	Against flow	EARL ARMSTRONG	<a href="#">65</a>	<a href="#">64</a>
5	1	3	1	MHSA-46. MHSA-45.	MHSA-46. --> MHSA-45.	Direction of flow	EARL ARMSTRONG	<a href="#">70</a>	<a href="#">69</a>
0	1	3	1	MHSA-.42 MHSA-.41	MHSA-.42 --> MHSA-.41	Direction of flow	EARL ARMSTRONG	<a href="#">20</a>	<a href="#">19</a>

WL - Water level (37 of 80 items)

%	Qty	OPG	ICG	Pipe	Start/End	Direction	Road	Picture	Page
15	1	3	1	MHSA-49 MHSA-48	MHSA-49 --> MHSA-48	Direction of flow	HIGH RD	<a href="#">76</a>	<a href="#">75</a>
10	1	3	1	MHSA-45... MHSA-44...	MHSA-44... --> MHSA-45...	Direction of flow	EARL ARMSTRONG	<a href="#">67</a>	<a href="#">66</a>
10	1	3	1	MHSA-47... MHSA-46...	MHSA-47... --> MHSA-46...	Direction of flow	EARL ARMSTRONG	<a href="#">72</a>	<a href="#">71</a>
10	1	3	1	MHSA-49 MHSA-48	MHSA-49 --> MHSA-48	Direction of flow	HIGH RD	<a href="#">76</a>	<a href="#">75</a>
10		3	1	MHSA-30 MHSA-29	MHSA-30 --> MHSA-29	Direction of flow	EARL ARMSTRONG		<a href="#">31</a>

WL - Water level (37 of 80 items)

%	Qty	OPG	ICG	Pipe	Start/End	Direction	Road	Picture	Page
10		1	1	MHSA-40 MHSA-39	MHSA-40 --> MHSA-39	Direction of flow	EARL ARMSTRONG		<a href="#">52</a>
10		3	1	MHSA-44 MHSA-45	MHSA-44 --> MHSA-45	Against flow	EARL ARMSTRONG		<a href="#">64</a>
5	1	3	1	MHSA-45... MHSA-44...	MHSA-44... --> MHSA-45...	Direction of flow	EARL ARMSTRONG	<a href="#">68</a>	<a href="#">66</a>
5		3	1	MHSA-.42 MHSA-.41	MHSA-.42 --> MHSA-.41	Direction of flow	EARL ARMSTRONG		<a href="#">19</a>
5		3	1	MHSA-28 MHSA-29	MHSA-28 --> MHSA-29	Against flow	EARL ARMSTRONG		<a href="#">22</a>
5		3	1	MHSA-28A MHSA-28	MHSA-28A --> MHSA-28	Against flow	EARL ARMSTRONG		<a href="#">24</a>
5		3	1	MHSA-28A NORTH	MHSA-28A --> NORTH	Direction of flow	EARL ARMSTRONG		<a href="#">27</a>
5		3	1	MHSA-29 MHSA-30	MHSA-29 --> MHSA-30	Against flow	EARL ARMSTRONG		<a href="#">29</a>
5		3	1	MHSA-31 MHSA-30	MHSA-31 --> MHSA-30	Direction of flow	EARL ARMSTRONG		<a href="#">33</a>
5		3	1	MHSA-32 MHSA-31	MHSA-32 --> MHSA-31	Direction of flow	EARL ARMSTRONG		<a href="#">35</a>
5		1	1	MHSA-33 MHSA-32	MHSA-33 --> MHSA-32	Direction of flow	EARL ARMSTRONG		<a href="#">37</a>
5		3	1	MHSA-33 MHSA-34	MHSA-33 --> MHSA-34	Against flow	EARL ARMSTRONG		<a href="#">39</a>
5		1	1	MHSA-35 MHSA-34	MHSA-35 --> MHSA-34	Direction of flow	EARL ARMSTRONG		<a href="#">41</a>
5		1	1	MHSA-36 MHSA-35	MHSA-36 --> MHSA-35	Direction of flow	EARL ARMSTRONG		<a href="#">43</a>
5		1	1	MHSA-37. MHSA-36.	MHSA-37. --> MHSA-36.	Direction of flow	EARL ARMSTRONG		<a href="#">45</a>
5		1	1	MHSA-38 MHSA-37	MHSA-38 --> MHSA-37	Direction of flow	EARL ARMSTRONG		<a href="#">47</a>
5		3	1	MHSA-39 MHSA-38	MHSA-39 --> MHSA-38	Direction of flow	EARL ARMSTRONG		<a href="#">49</a>
5		1	1	MHSA-41 MHSA-40	MHSA-41 --> MHSA-40	Direction of flow	EARL ARMSTRONG		<a href="#">54</a>
5		1	1	MHSA-42 MHSA-43	MHSA-42 --> MHSA-43	Against flow	EARL ARMSTRONG		<a href="#">58</a>
5		1	1	MHSA-43 MHSA-42	MHSA-43 --> MHSA-42	Direction of flow	EARL ARMSTRONG		<a href="#">60</a>
5		3	1	MHSA-44 MHSA-43	MHSA-44 --> MHSA-43	Direction of flow	EARL ARMSTRONG		<a href="#">62</a>
5		3	1	MHSA-45... MHSA-44...	MHSA-44... --> MHSA-45...	Direction of flow	EARL ARMSTRONG		<a href="#">66</a>
5		3	1	MHSA-46. MHSA-45.	MHSA-46. --> MHSA-45.	Direction of flow	EARL ARMSTRONG		<a href="#">69</a>
5		3	1	MHSA-47... MHSA-46...	MHSA-47... --> MHSA-46...	Direction of flow	EARL ARMSTRONG		<a href="#">71</a>
5		3	1	MHSA-48 MHSA-47	MHSA-48 --> MHSA-47	Direction of flow	HIGH RD		<a href="#">73</a>
5		3	1	MHSA-49 MHSA-48	MHSA-49 --> MHSA-48	Direction of flow	HIGH RD		<a href="#">75</a>
5		1	1	MHSA-50 MHSA-49	MHSA-50 --> MHSA-49	Direction of flow	HIGH RD		<a href="#">78</a>
5		1	1	MHSA-51... MHSA-50...	MHSA-51... --> MHSA-50...	Direction of flow	HIGH RD		<a href="#">80</a>
5		1	1	MHSA-52.. MHSA-51..	MHSA-52.. --> MHSA-51..	Direction of flow	HIGH RD		<a href="#">82</a>
5		3	1	MHSA-53 MHSA-52	MHSA-53 --> MHSA-52	Direction of flow	HIGH RD		<a href="#">84</a>
5		3	1	MHSA-54 MHSA-53	MHSA-54 --> MHSA-53	Direction of flow	HIGH RD		<a href="#">86</a>
5		1	1	MHSA-55.. MHSA-54..	MHSA-55.. --> MHSA-54..	Direction of flow	HIGH RD		<a href="#">88</a>

59 items

MH - Manhole / node (59 of 59 items)

Qty	Pipe	Start/End	Direction	Road	Picture	Page
	MHSA-.42 MHSA-.41	MHSA-.42 --> MHSA-.41	Direction of flow	EARL ARMSTRONG		<a href="#">19</a>
	MHSA-.42 MHSA-.41	MHSA-.42 --> MHSA-.41	Direction of flow	EARL ARMSTRONG	<a href="#">20</a>	<a href="#">19</a>
	MHSA-28 MHSA-29	MHSA-28 --> MHSA-29	Against flow	EARL ARMSTRONG	<a href="#">23</a>	<a href="#">22</a>
	MHSA-28 MHSA-29	MHSA-28 --> MHSA-29	Against flow	EARL ARMSTRONG		<a href="#">22</a>
	MHSA-28A MHSA-28	MHSA-28A --> MHSA-28	Against flow	EARL ARMSTRONG	<a href="#">25</a>	<a href="#">24</a>
	MHSA-28A MHSA-28	MHSA-28A --> MHSA-28	Against flow	EARL ARMSTRONG		<a href="#">24</a>
	MHSA-28A NORTH	MHSA-28A --> NORTH	Direction of flow	EARL ARMSTRONG		<a href="#">27</a>
	MHSA-29 MHSA-30	MHSA-29 --> MHSA-30	Against flow	EARL ARMSTRONG		<a href="#">29</a>
	MHSA-30 MHSA-29	MHSA-30 --> MHSA-29	Direction of flow	EARL ARMSTRONG		<a href="#">31</a>
	MHSA-31 MHSA-30	MHSA-31 --> MHSA-30	Direction of flow	EARL ARMSTRONG	<a href="#">34</a>	<a href="#">33</a>
	MHSA-31 MHSA-30	MHSA-31 --> MHSA-30	Direction of flow	EARL ARMSTRONG		<a href="#">33</a>
	MHSA-32 MHSA-31	MHSA-32 --> MHSA-31	Direction of flow	EARL ARMSTRONG		<a href="#">35</a>
	MHSA-32 MHSA-31	MHSA-32 --> MHSA-31	Direction of flow	EARL ARMSTRONG	<a href="#">36</a>	<a href="#">35</a>
	MHSA-33 MHSA-32	MHSA-33 --> MHSA-32	Direction of flow	EARL ARMSTRONG		<a href="#">37</a>
	MHSA-33 MHSA-32	MHSA-33 --> MHSA-32	Direction of flow	EARL ARMSTRONG	<a href="#">38</a>	<a href="#">37</a>
	MHSA-33 MHSA-34	MHSA-33 --> MHSA-34	Against flow	EARL ARMSTRONG		<a href="#">39</a>
	MHSA-33 MHSA-34	MHSA-33 --> MHSA-34	Against flow	EARL ARMSTRONG	<a href="#">40</a>	<a href="#">39</a>
	MHSA-35 MHSA-34	MHSA-35 --> MHSA-34	Direction of flow	EARL ARMSTRONG		<a href="#">41</a>
	MHSA-35 MHSA-34	MHSA-35 --> MHSA-34	Direction of flow	EARL ARMSTRONG	<a href="#">42</a>	<a href="#">41</a>
	MHSA-36 MHSA-35	MHSA-36 --> MHSA-35	Direction of flow	EARL ARMSTRONG		<a href="#">43</a>
	MHSA-36 MHSA-35	MHSA-36 --> MHSA-35	Direction of flow	EARL ARMSTRONG	<a href="#">44</a>	<a href="#">43</a>
	MHSA-37. MHSA-36.	MHSA-37. --> MHSA-36.	Direction of flow	EARL ARMSTRONG		<a href="#">45</a>
	MHSA-37. MHSA-36.	MHSA-37. --> MHSA-36.	Direction of flow	EARL ARMSTRONG	<a href="#">46</a>	<a href="#">45</a>
	MHSA-38 MHSA-37	MHSA-38 --> MHSA-37	Direction of flow	EARL ARMSTRONG	<a href="#">48</a>	<a href="#">47</a>
	MHSA-38 MHSA-37	MHSA-38 --> MHSA-37	Direction of flow	EARL ARMSTRONG		<a href="#">47</a>
	MHSA-39 MHSA-38	MHSA-39 --> MHSA-38	Direction of flow	EARL ARMSTRONG	<a href="#">51</a>	<a href="#">49</a>
	MHSA-39 MHSA-38	MHSA-39 --> MHSA-38	Direction of flow	EARL ARMSTRONG		<a href="#">49</a>
	MHSA-40 MHSA-39	MHSA-40 --> MHSA-39	Direction of flow	EARL ARMSTRONG	<a href="#">53</a>	<a href="#">52</a>
	MHSA-40 MHSA-39	MHSA-40 --> MHSA-39	Direction of flow	EARL ARMSTRONG		<a href="#">52</a>
	MHSA-41 MHSA-40	MHSA-41 --> MHSA-40	Direction of flow	EARL ARMSTRONG	<a href="#">55</a>	<a href="#">54</a>
	MHSA-41 MHSA-40	MHSA-41 --> MHSA-40	Direction of flow	EARL ARMSTRONG		<a href="#">54</a>
	MHSA-42 MHSA-43	MHSA-42 --> MHSA-43	Against flow	EARL ARMSTRONG		<a href="#">58</a>
	MHSA-43 MHSA-42	MHSA-43 --> MHSA-42	Direction of flow	EARL ARMSTRONG		<a href="#">60</a>
	MHSA-44 MHSA-43	MHSA-44 --> MHSA-43	Direction of flow	EARL ARMSTRONG		<a href="#">62</a>
	MHSA-44 MHSA-43	MHSA-44 --> MHSA-43	Direction of flow	EARL ARMSTRONG	<a href="#">63</a>	<a href="#">62</a>
	MHSA-44 MHSA-45	MHSA-44 --> MHSA-45	Against flow	EARL ARMSTRONG	<a href="#">65</a>	<a href="#">64</a>
	MHSA-44 MHSA-45	MHSA-44 --> MHSA-45	Against flow	EARL ARMSTRONG		<a href="#">64</a>
	MHSA-45... MHSA-44...	MHSA-44... --> MHSA-45...	Direction of flow	EARL ARMSTRONG	<a href="#">68</a>	<a href="#">66</a>
	MHSA-45... MHSA-44...	MHSA-44... --> MHSA-45...	Direction of flow	EARL ARMSTRONG		<a href="#">66</a>
	MHSA-46. MHSA-45.	MHSA-46. --> MHSA-45.	Direction of flow	EARL ARMSTRONG		<a href="#">69</a>
	MHSA-46. MHSA-45.	MHSA-46. --> MHSA-45.	Direction of flow	EARL ARMSTRONG	<a href="#">70</a>	<a href="#">69</a>
	MHSA-47... MHSA-46...	MHSA-47... --> MHSA-46...	Direction of flow	EARL ARMSTRONG	<a href="#">72</a>	<a href="#">71</a>
	MHSA-47... MHSA-46...	MHSA-47... --> MHSA-46...	Direction of flow	EARL ARMSTRONG		<a href="#">71</a>
	MHSA-48 MHSA-47	MHSA-48 --> MHSA-47	Direction of flow	HIGH RD		<a href="#">73</a>
	MHSA-48 MHSA-47	MHSA-48 --> MHSA-47	Direction of flow	HIGH RD	<a href="#">74</a>	<a href="#">73</a>
	MHSA-49 MHSA-48	MHSA-49 --> MHSA-48	Direction of flow	HIGH RD	<a href="#">76</a>	<a href="#">75</a>
	MHSA-49 MHSA-48	MHSA-49 --> MHSA-48	Direction of flow	HIGH RD		<a href="#">75</a>
	MHSA-50 MHSA-49	MHSA-50 --> MHSA-49	Direction of flow	HIGH RD	<a href="#">79</a>	<a href="#">78</a>
	MHSA-50 MHSA-49	MHSA-50 --> MHSA-49	Direction of flow	HIGH RD		<a href="#">78</a>
	MHSA-51... MHSA-50...	MHSA-51... --> MHSA-50...	Direction of flow	HIGH RD	<a href="#">81</a>	<a href="#">80</a>
	MHSA-51... MHSA-50...	MHSA-51... --> MHSA-50...	Direction of flow	HIGH RD		<a href="#">80</a>
	MHSA-52.. MHSA-51..	MHSA-52.. --> MHSA-51..	Direction of flow	HIGH RD		<a href="#">82</a>
	MHSA-52.. MHSA-51..	MHSA-52.. --> MHSA-51..	Direction of flow	HIGH RD	<a href="#">83</a>	<a href="#">82</a>
	MHSA-53 MHSA-52	MHSA-53 --> MHSA-52	Direction of flow	HIGH RD	<a href="#">85</a>	<a href="#">84</a>
	MHSA-53 MHSA-52	MHSA-53 --> MHSA-52	Direction of flow	HIGH RD		<a href="#">84</a>
	MHSA-54 MHSA-53	MHSA-54 --> MHSA-53	Direction of flow	HIGH RD	<a href="#">87</a>	<a href="#">86</a>
	MHSA-54 MHSA-53	MHSA-54 --> MHSA-53	Direction of flow	HIGH RD		<a href="#">86</a>
	MHSA-55.. MHSA-54..	MHSA-55.. --> MHSA-54..	Direction of flow	HIGH RD		<a href="#">88</a>

MH - Manhole / node (59 of 59 items)

Qty	Pipe	Start/End	Direction	Road	Picture	Page
	MHSA-55.. MHSA-54..	MHSA-55.. --> MHSA-54..	Direction of flow	HIGH RD	<a href="#">89</a>	<a href="#">88</a>



72 items

FH - Finish of Survey (27 of 72 items)

Qty	Pipe	Start/End	Direction	Road	Picture	Page
	MHSA-.42 MHSA-.41	MHSA-.42 --> MHSA-.41	Direction of flow	EARL ARMSTRONG	<a href="#">21</a>	<a href="#">19</a>
	MHSA-28 MHSA-29	MHSA-28 --> MHSA-29	Against flow	EARL ARMSTRONG	<a href="#">23</a>	<a href="#">22</a>
	MHSA-28A MHSA-28	MHSA-28A --> MHSA-28	Against flow	EARL ARMSTRONG	<a href="#">26</a>	<a href="#">24</a>
	MHSA-31 MHSA-30	MHSA-31 --> MHSA-30	Direction of flow	EARL ARMSTRONG	<a href="#">34</a>	<a href="#">33</a>
	MHSA-32 MHSA-31	MHSA-32 --> MHSA-31	Direction of flow	EARL ARMSTRONG	<a href="#">36</a>	<a href="#">35</a>
	MHSA-33 MHSA-32	MHSA-33 --> MHSA-32	Direction of flow	EARL ARMSTRONG	<a href="#">38</a>	<a href="#">37</a>
	MHSA-33 MHSA-34	MHSA-33 --> MHSA-34	Against flow	EARL ARMSTRONG	<a href="#">40</a>	<a href="#">39</a>
	MHSA-35 MHSA-34	MHSA-35 --> MHSA-34	Direction of flow	EARL ARMSTRONG	<a href="#">42</a>	<a href="#">41</a>
	MHSA-36 MHSA-35	MHSA-36 --> MHSA-35	Direction of flow	EARL ARMSTRONG	<a href="#">44</a>	<a href="#">43</a>
	MHSA-37. MHSA-36.	MHSA-37. --> MHSA-36.	Direction of flow	EARL ARMSTRONG	<a href="#">46</a>	<a href="#">45</a>
	MHSA-38 MHSA-37	MHSA-38 --> MHSA-37	Direction of flow	EARL ARMSTRONG	<a href="#">48</a>	<a href="#">47</a>
	MHSA-39 MHSA-38	MHSA-39 --> MHSA-38	Direction of flow	EARL ARMSTRONG	<a href="#">51</a>	<a href="#">49</a>
	MHSA-40 MHSA-39	MHSA-40 --> MHSA-39	Direction of flow	EARL ARMSTRONG	<a href="#">53</a>	<a href="#">52</a>
	MHSA-41 MHSA-40	MHSA-41 --> MHSA-40	Direction of flow	EARL ARMSTRONG	<a href="#">55</a>	<a href="#">54</a>
	MHSA-44 MHSA-43	MHSA-44 --> MHSA-43	Direction of flow	EARL ARMSTRONG	<a href="#">63</a>	<a href="#">62</a>
	MHSA-44 MHSA-45	MHSA-44 --> MHSA-45	Against flow	EARL ARMSTRONG	<a href="#">65</a>	<a href="#">64</a>
	MHSA-45... MHSA-44...	MHSA-44... --> MHSA-45...	Direction of flow	EARL ARMSTRONG	<a href="#">68</a>	<a href="#">66</a>
	MHSA-46. MHSA-45.	MHSA-46. --> MHSA-45.	Direction of flow	EARL ARMSTRONG	<a href="#">70</a>	<a href="#">69</a>
	MHSA-47... MHSA-46...	MHSA-47... --> MHSA-46...	Direction of flow	EARL ARMSTRONG	<a href="#">72</a>	<a href="#">71</a>
	MHSA-48 MHSA-47	MHSA-48 --> MHSA-47	Direction of flow	HIGH RD	<a href="#">74</a>	<a href="#">73</a>
	MHSA-49 MHSA-48	MHSA-49 --> MHSA-48	Direction of flow	HIGH RD	<a href="#">77</a>	<a href="#">75</a>
	MHSA-50 MHSA-49	MHSA-50 --> MHSA-49	Direction of flow	HIGH RD	<a href="#">79</a>	<a href="#">78</a>
	MHSA-51... MHSA-50...	MHSA-51... --> MHSA-50...	Direction of flow	HIGH RD	<a href="#">81</a>	<a href="#">80</a>
	MHSA-52.. MHSA-51..	MHSA-52.. --> MHSA-51..	Direction of flow	HIGH RD	<a href="#">83</a>	<a href="#">82</a>
	MHSA-53 MHSA-52	MHSA-53 --> MHSA-52	Direction of flow	HIGH RD	<a href="#">85</a>	<a href="#">84</a>
	MHSA-54 MHSA-53	MHSA-54 --> MHSA-53	Direction of flow	HIGH RD	<a href="#">87</a>	<a href="#">86</a>
	MHSA-55.. MHSA-54..	MHSA-55.. --> MHSA-54..	Direction of flow	HIGH RD	<a href="#">89</a>	<a href="#">88</a>

GO - General observation at this point (8 of 72 items)

Qty	Pipe	Start/End	Direction	Road	Picture	Page
1	MHSA-28A MHSA-28	MHSA-28A --> MHSA-28	Against flow	EARL ARMSTRONG	<a href="#">25</a>	<a href="#">24</a>
1	MHSA-28A MHSA-28	MHSA-28A --> MHSA-28	Against flow	EARL ARMSTRONG	<a href="#">25</a>	<a href="#">24</a>
1	MHSA-28A NORTH	MHSA-28A --> NORTH	Direction of flow	EARL ARMSTRONG	<a href="#">28</a>	<a href="#">27</a>
1	MHSA-29 MHSA-30	MHSA-29 --> MHSA-30	Against flow	EARL ARMSTRONG	<a href="#">30</a>	<a href="#">29</a>
1	MHSA-36 MHSA-35	MHSA-36 --> MHSA-35	Direction of flow	EARL ARMSTRONG	<a href="#">44</a>	<a href="#">43</a>
1	MHSA-42 MHSA-43	MHSA-42 --> MHSA-43	Against flow	EARL ARMSTRONG	<a href="#">59</a>	<a href="#">58</a>
1	MHSA-43 MHSA-42	MHSA-43 --> MHSA-42	Direction of flow	EARL ARMSTRONG	<a href="#">61</a>	<a href="#">60</a>
1	MHSA-45... MHSA-44...	MHSA-44... --> MHSA-45...	Direction of flow	EARL ARMSTRONG	<a href="#">67</a>	<a href="#">66</a>

SA - Survey abandoned (5 of 72 items)

Qty	Pipe	Start/End	Direction	Road	Picture	Page
	MHSA-28A NORTH	MHSA-28A --> NORTH	Direction of flow	EARL ARMSTRONG	<a href="#">28</a>	<a href="#">27</a>
	MHSA-29 MHSA-30	MHSA-29 --> MHSA-30	Against flow	EARL ARMSTRONG	<a href="#">30</a>	<a href="#">29</a>
	MHSA-30 MHSA-29	MHSA-30 --> MHSA-29	Direction of flow	EARL ARMSTRONG	<a href="#">32</a>	<a href="#">31</a>
	MHSA-42 MHSA-43	MHSA-42 --> MHSA-43	Against flow	EARL ARMSTRONG	<a href="#">59</a>	<a href="#">58</a>
	MHSA-43 MHSA-42	MHSA-43 --> MHSA-42	Direction of flow	EARL ARMSTRONG	<a href="#">61</a>	<a href="#">60</a>

ST - Start of Survey (32 of 72 items)

Qty	Pipe	Start/End	Direction	Road	Picture	Page
	MHSA-.42 MHSA-.41	MHSA-.42 --> MHSA-.41	Direction of flow	EARL ARMSTRONG		<a href="#">19</a>
	MHSA-28 MHSA-29	MHSA-28 --> MHSA-29	Against flow	EARL ARMSTRONG		<a href="#">22</a>
	MHSA-28A MHSA-28	MHSA-28A --> MHSA-28	Against flow	EARL ARMSTRONG		<a href="#">24</a>
	MHSA-28A NORTH	MHSA-28A --> NORTH	Direction of flow	EARL ARMSTRONG		<a href="#">27</a>
	MHSA-29 MHSA-30	MHSA-29 --> MHSA-30	Against flow	EARL ARMSTRONG		<a href="#">29</a>
	MHSA-30 MHSA-29	MHSA-30 --> MHSA-29	Direction of flow	EARL ARMSTRONG		<a href="#">31</a>
	MHSA-31 MHSA-30	MHSA-31 --> MHSA-30	Direction of flow	EARL ARMSTRONG		<a href="#">33</a>
	MHSA-32 MHSA-31	MHSA-32 --> MHSA-31	Direction of flow	EARL ARMSTRONG		<a href="#">35</a>

ST - Start of Survey (32 of 72 items)

Qty	Pipe	Start/End	Direction	Road	Picture	Page
	MHSA-33 MHSA-32	MHSA-33 --> MHSA-32	Direction of flow	EARL ARMSTRONG		<a href="#">37</a>
	MHSA-33 MHSA-34	MHSA-33 --> MHSA-34	Against flow	EARL ARMSTRONG		<a href="#">39</a>
	MHSA-35 MHSA-34	MHSA-35 --> MHSA-34	Direction of flow	EARL ARMSTRONG		<a href="#">41</a>
	MHSA-36 MHSA-35	MHSA-36 --> MHSA-35	Direction of flow	EARL ARMSTRONG		<a href="#">43</a>
	MHSA-37. MHSA-36.	MHSA-37. --> MHSA-36.	Direction of flow	EARL ARMSTRONG		<a href="#">45</a>
	MHSA-38 MHSA-37	MHSA-38 --> MHSA-37	Direction of flow	EARL ARMSTRONG		<a href="#">47</a>
	MHSA-39 MHSA-38	MHSA-39 --> MHSA-38	Direction of flow	EARL ARMSTRONG		<a href="#">49</a>
	MHSA-40 MHSA-39	MHSA-40 --> MHSA-39	Direction of flow	EARL ARMSTRONG		<a href="#">52</a>
	MHSA-41 MHSA-40	MHSA-41 --> MHSA-40	Direction of flow	EARL ARMSTRONG		<a href="#">54</a>
	MHSA-42 MHSA-43	MHSA-42 --> MHSA-43	Against flow	EARL ARMSTRONG		<a href="#">58</a>
	MHSA-43 MHSA-42	MHSA-43 --> MHSA-42	Direction of flow	EARL ARMSTRONG		<a href="#">60</a>
	MHSA-44 MHSA-43	MHSA-44 --> MHSA-43	Direction of flow	EARL ARMSTRONG		<a href="#">62</a>
	MHSA-44 MHSA-45	MHSA-44 --> MHSA-45	Against flow	EARL ARMSTRONG		<a href="#">64</a>
	MHSA-45... MHSA-44...	MHSA-44... --> MHSA-45...	Direction of flow	EARL ARMSTRONG		<a href="#">66</a>
	MHSA-46. MHSA-45.	MHSA-46. --> MHSA-45.	Direction of flow	EARL ARMSTRONG		<a href="#">69</a>
	MHSA-47... MHSA-46...	MHSA-47... --> MHSA-46...	Direction of flow	EARL ARMSTRONG		<a href="#">71</a>
	MHSA-48 MHSA-47	MHSA-48 --> MHSA-47	Direction of flow	HIGH RD		<a href="#">73</a>
	MHSA-49 MHSA-48	MHSA-49 --> MHSA-48	Direction of flow	HIGH RD		<a href="#">75</a>
	MHSA-50 MHSA-49	MHSA-50 --> MHSA-49	Direction of flow	HIGH RD		<a href="#">78</a>
	MHSA-51... MHSA-50...	MHSA-51... --> MHSA-50...	Direction of flow	HIGH RD		<a href="#">80</a>
	MHSA-52.. MHSA-51..	MHSA-52.. --> MHSA-51..	Direction of flow	HIGH RD		<a href="#">82</a>
	MHSA-53 MHSA-52	MHSA-53 --> MHSA-52	Direction of flow	HIGH RD		<a href="#">84</a>
	MHSA-54 MHSA-53	MHSA-54 --> MHSA-53	Direction of flow	HIGH RD		<a href="#">86</a>
	MHSA-55.. MHSA-54..	MHSA-55.. --> MHSA-54..	Direction of flow	HIGH RD		<a href="#">88</a>





### Pipe identification

<b>Pipe:</b> MHSA-.42 MHSA-.41	<b>Direction of inspection:</b> MHSA-.42 --> MHSA-.41
<b>Direction of flow:</b> MHSA-.42 --> MHSA-.41	<b>Direction:</b> Direction of flow

### Pipe location

<b>Road:</b> EARL ARMSTRONG	<b>City:</b> Template
<b>Crossroad:</b> EARL ARMSTRONG	<b>Area:</b>
<b>Location:</b> Main road - Suburban/Rural	<b>Road segment:</b>

### Pipe characteristics

<b>Category:</b> Sanitary	<b>Size:</b> 250
<b>Shape:</b> Circular	<b>Width:</b>
<b>Material:</b> Polyvinyl chloride	<b>Total length:</b> 119.00
<b>Lining:</b>	<b>Pipe unit length:</b> 4.00
<b>Type:</b> Main	<b>Year laid:</b>
<b>Invert (upstream):</b>	<b>Invert (downstream):</b>
<b>Depth (upstream):</b>	<b>Depth (downstream):</b>
<b>Cover level (upstream):</b>	<b>Cover level (downstream):</b>

### Additional details

<b>Date:</b> 11/12/2018 9:19 AM	<b>Survey Abandoned:</b>
<b>Client project #:</b> Sanitary Sewer	<b>Inspected length:</b> 119.00
<b>Contractor project #:</b> HARD ROCK CASINO LP	<b>Pre-cleaning:</b> <input checked="" type="checkbox"/>
<b>Project type:</b> Video Inspection	<b>Blocked flow:</b> <input type="checkbox"/>
<b>Project supplier:</b>	<b>Regular CCTV:</b> <input type="checkbox"/>
<b>Client:</b> Hard Rock Ottawa L.P	<b>Reinspect with ZOOM:</b> <input type="checkbox"/>
<b>Purpose:</b> Assessment of complete remedial or renovation works	<b>Medium #:</b>
<b>Weather:</b> Light Snow	<b>Start position:</b>
<b>Operator:</b> RS	<b>End position:</b>
<b>Analyst:</b>	

### Internal Condition

<b>Grade:</b> 1	<b>Grade:</b> 3
<b>Total:</b> 0	<b>Total:</b> 7
<b>Peak:</b> 0	<b>Peak:</b> 2

### Operational Performance

### Comments

--

### Other information

<b>Other 1:</b> 455019	<b>Other 7:</b>
<b>Other 2:</b>	<b>Other 8:</b>
<b>Other 3:</b>	<b>Other 9:</b>
<b>Other 4:</b>	<b>Other 10:</b>
<b>Other 5:</b>	<b>PI5 (MAMR):</b>
<b>Other 6:</b>	<b>PI6 (MAMR):</b>

**#1 0.00**  
ST - Start of Survey

**#3 0.00**  
WL - Water level, 5%

**#2 0.00**  
MH - Manhole / node, MHSA-.42

**#4 5.90**  
DEG - Debris grease, from 5 o'clock to 7 o'clock, 5%



**#5 35.70**  
DES - Debris silt, 10%



**#6 35.70**  
(S1) DES - Debris silt, 5%



**#7 119.00**  
(F1) DES - Debris silt, 0%

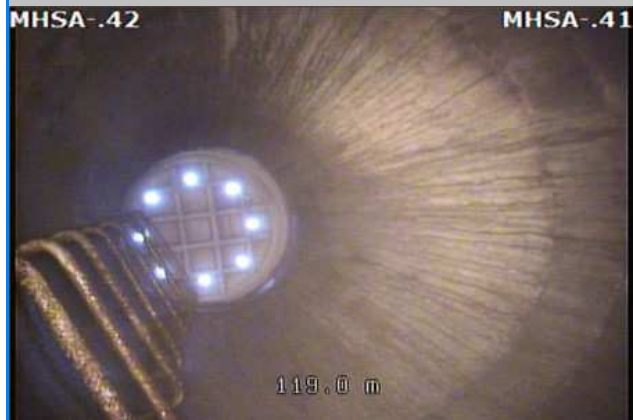

**#8 119.00**  
MH - Manhole / node, MHSA-.41





### Pipe identification

<b>Pipe:</b> MHSA-28 MHSA-29	<b>Direction of inspection:</b> MHSA-28 --> MHSA-29
<b>Direction of flow:</b> MHSA-29 --> MHSA-28	<b>Direction:</b> Against flow

### Pipe location

<b>Road:</b> EARL ARMSTRONG	<b>City:</b> Template
<b>Crossroad:</b> S BEND / POOR ACCESS	<b>Area:</b>
<b>Location:</b> Main road - Suburban/Rural	<b>Road segment:</b>

### Pipe characteristics

<b>Category:</b> Sanitary	<b>Size:</b> 250
<b>Shape:</b> Circular	<b>Width:</b>
<b>Material:</b> Polyvinyl chloride	<b>Total length:</b> 72.00
<b>Lining:</b>	<b>Pipe unit length:</b> 2.80
<b>Type:</b> Main	<b>Year laid:</b>
<b>Invert (upstream):</b>	<b>Invert (downstream):</b>
<b>Depth (upstream):</b>	<b>Depth (downstream):</b>
<b>Cover level (upstream):</b>	<b>Cover level (downstream):</b>

### Additional details

<b>Date:</b> 07/01/2019 12:07 PM	<b>Survey Abandoned:</b>
<b>Client project #:</b> Sanitary Sewer	<b>Inspected length:</b> 72.00
<b>Contractor project #:</b> HARD ROCK CASINO LP	<b>Pre-cleaning:</b> <input checked="" type="checkbox"/>
<b>Project type:</b> Video Inspection	<b>Blocked flow:</b> <input type="checkbox"/>
<b>Project supplier:</b>	<b>Regular CCTV:</b> <input type="checkbox"/>
<b>Client:</b> Hard Rock Ottawa L.P	<b>Reinspect with ZOOM:</b> <input type="checkbox"/>
<b>Purpose:</b> Assessment of complete remedial or renovation works	<b>Medium #:</b>
<b>Weather:</b> Dry	<b>Start position:</b>
<b>Operator:</b> RS	<b>End position:</b>
<b>Analyst:</b>	

### Internal Condition

<b>Grade:</b> 1	<b>Grade:</b> 3
<b>Total:</b> 0	<b>Total:</b> 4
<b>Peak:</b> 0	<b>Peak:</b> 2

### Operational Performance

### Comments

--

### Other information

<b>Other 1:</b> 455019	<b>Other 7:</b>
<b>Other 2:</b>	<b>Other 8:</b>
<b>Other 3:</b>	<b>Other 9:</b>
<b>Other 4:</b>	<b>Other 10:</b>
<b>Other 5:</b>	<b>PI5 (MAMR):</b>
<b>Other 6:</b>	<b>PI6 (MAMR):</b>



**#1 0.00**  
ST - Start of Survey

**#3 0.00**  
WL - Water level, 5%

**#2 0.00**  
MH - Manhole / node, MHSA-28

**#4 1.60**  
(S1) DEG - Debris grease, from 4 o'clock to 8 o'clock, 5%



**#5 72.00**  
(F1) DEG - Debris grease, from 4 o'clock to 8 o'clock, 5%



**#6 72.00**  
MH - Manhole / node, MHSA-29



**#7 72.00**  
FH - Finish of Survey



### Pipe identification

<b>Pipe:</b> MHSA-28A MHSA-28	<b>Direction of inspection:</b> MHSA-28A --> MHSA-28
<b>Direction of flow:</b> MHSA-28 --> MHSA-28A	<b>Direction:</b> Against flow

### Pipe location

<b>Road:</b> EARL ARMSTRONG	<b>City:</b> Template
<b>Crossroad:</b>	<b>Area:</b>
<b>Location:</b> Main road - Suburban/Rural	<b>Road segment:</b>

### Pipe characteristics

<b>Category:</b> Sanitary	<b>Size:</b> 250
<b>Shape:</b> Circular	<b>Width:</b>
<b>Material:</b> Polyvinyl chloride	<b>Total length:</b> 119.50
<b>Lining:</b>	<b>Pipe unit length:</b> 2.80
<b>Type:</b> Main	<b>Year laid:</b>
<b>Invert (upstream):</b>	<b>Invert (downstream):</b>
<b>Depth (upstream):</b>	<b>Depth (downstream):</b>
<b>Cover level (upstream):</b>	<b>Cover level (downstream):</b>

### Additional details

<b>Date:</b> 07/01/2019 11:42 AM	<b>Survey Abandoned:</b>
<b>Client project #:</b> Sanitary Sewer	<b>Inspected length:</b> 119.50
<b>Contractor project #:</b> HARD ROCK CASINO LP	<b>Pre-cleaning:</b> <input checked="" type="checkbox"/>
<b>Project type:</b> Video Inspection	<b>Blocked flow:</b> <input type="checkbox"/>
<b>Project supplier:</b>	<b>Regular CCTV:</b> <input type="checkbox"/>
<b>Client:</b> Hard Rock Ottawa L.P	<b>Reinspect with ZOOM:</b> <input type="checkbox"/>
<b>Purpose:</b> Assessment of complete remedial or renovation works	<b>Medium #:</b>
<b>Weather:</b> Dry	<b>Start position:</b>
<b>Operator:</b> RS	<b>End position:</b>
<b>Analyst:</b>	

### Internal Condition

<b>Grade:</b> 1	<b>Grade:</b> 3
<b>Total:</b> 0	<b>Total:</b> 4
<b>Peak:</b> 0	<b>Peak:</b> 2

### Operational Performance

### Comments

--

### Other information

<b>Other 1:</b> 455019	<b>Other 7:</b>
<b>Other 2:</b>	<b>Other 8:</b>
<b>Other 3:</b>	<b>Other 9:</b>
<b>Other 4:</b>	<b>Other 10:</b>
<b>Other 5:</b>	<b>PI5 (MAMR):</b>
<b>Other 6:</b>	<b>PI6 (MAMR):</b>

**#1 0.00**  
ST - Start of Survey

**#3 0.00**  
WL - Water level, 5%

**#2 0.00**  
MH - Manhole / node, MHSA-28A

**#4 0.00**  
GO - General observation at this point, at 6 o'clock, drop pipe



**#5 3.90**  
(S1) DEG - Debris grease, from 4 o'clock to 8 o'clock, 5%



**#6 34.00**  
GO - General observation at this point, from 1 o'clock to 12 o'clock, buried manhole at 34m to the east of 28



**#7 119.50**  
(F1) DEG - Debris grease, from 4 o'clock to 8 o'clock, 5%



**#8 119.50**  
MH - Manhole / node, MHSA-28





### Pipe identification

<b>Pipe:</b> MHSA-28A NORTH	<b>Direction of inspection:</b> MHSA-28A --> NORTH
<b>Direction of flow:</b> MHSA-28A --> NORTH	<b>Direction:</b> Direction of flow

### Pipe location

<b>Road:</b> EARL ARMSTRONG	<b>City:</b> Template
<b>Crossroad:</b>	<b>Area:</b>
<b>Location:</b> Main road - Suburban/Rural	<b>Road segment:</b>

### Pipe characteristics

<b>Category:</b> Sanitary	<b>Size:</b> 250
<b>Shape:</b> Circular	<b>Width:</b>
<b>Material:</b> Polyvinyl chloride	<b>Total length:</b> 2.00
<b>Lining:</b>	<b>Pipe unit length:</b> 2.80
<b>Type:</b> Main	<b>Year laid:</b>
<b>Invert (upstream):</b>	<b>Invert (downstream):</b>
<b>Depth (upstream):</b>	<b>Depth (downstream):</b>
<b>Cover level (upstream):</b>	<b>Cover level (downstream):</b>

### Additional details

<b>Date:</b> 07/01/2019 1:05 PM	<b>Survey Abandoned:</b>
<b>Client project #:</b> Sanitary Sewer	<b>Inspected length:</b> 2.00
<b>Contractor project #:</b> HARD ROCK CASINO LP	<b>Pre-cleaning:</b> <input checked="" type="checkbox"/>
<b>Project type:</b> Video Inspection	<b>Blocked flow:</b> <input type="checkbox"/>
<b>Project supplier:</b>	<b>Regular CCTV:</b> <input type="checkbox"/>
<b>Client:</b> Hard Rock Ottawa L.P	<b>Reinspect with ZOOM:</b> <input type="checkbox"/>
<b>Purpose:</b> Assessment of complete remedial or renovation works	<b>Medium #:</b>
<b>Weather:</b> Dry	<b>Start position:</b>
<b>Operator:</b> RS	<b>End position:</b>
<b>Analyst:</b>	

### Internal Condition

<b>Grade:</b> 1	<b>Grade:</b> 3
<b>Total:</b> 0	<b>Total:</b> 2
<b>Peak:</b> 0	<b>Peak:</b> 2

### Operational Performance

### Comments

--

### Other information

<b>Other 1:</b> 455019	<b>Other 7:</b>
<b>Other 2:</b>	<b>Other 8:</b>
<b>Other 3:</b>	<b>Other 9:</b>
<b>Other 4:</b>	<b>Other 10:</b>
<b>Other 5:</b>	<b>PI5 (MAMR):</b>
<b>Other 6:</b>	<b>PI6 (MAMR):</b>

**#1 0.00**  
ST - Start of Survey

**#3 0.00**  
WL - Water level, 5%

**#2 0.00**  
MH - Manhole / node, MHSA-28A

**#4 0.00**  
DES - Debris silt, 10%



**#5 2.00**  
GO - General observation at this point, PASS SCOPE OF WORK



**#6 2.00**  
SA - Survey abandoned, PASS SCOPE OF WORK



### Pipe identification

<b>Pipe:</b> MHSA-29 MHSA-30	<b>Direction of inspection:</b> MHSA-29 --> MHSA-30
<b>Direction of flow:</b> MHSA-30 --> MHSA-29	<b>Direction:</b> Against flow

### Pipe location

<b>Road:</b> EARL ARMSTRONG	<b>City:</b> Template
<b>Crossroad:</b>	<b>Area:</b>
<b>Location:</b> Main road - Suburban/Rural	<b>Road segment:</b>

### Pipe characteristics

<b>Category:</b> Sanitary	<b>Size:</b> 250
<b>Shape:</b> Circular	<b>Width:</b>
<b>Material:</b> Polyvinyl chloride	<b>Total length:</b> 3.80
<b>Lining:</b>	<b>Pipe unit length:</b> 2.80
<b>Type:</b> Main	<b>Year laid:</b>
<b>Invert (upstream):</b>	<b>Invert (downstream):</b>
<b>Depth (upstream):</b>	<b>Depth (downstream):</b>
<b>Cover level (upstream):</b>	<b>Cover level (downstream):</b>

### Additional details

<b>Date:</b> 07/01/2019 12:31 PM	<b>Survey Abandoned:</b>
<b>Client project #:</b> Sanitary Sewer	<b>Inspected length:</b> 3.80
<b>Contractor project #:</b> HARD ROCK CASINO LP	<b>Pre-cleaning:</b> <input checked="" type="checkbox"/>
<b>Project type:</b> Video Inspection	<b>Blocked flow:</b> <input type="checkbox"/>
<b>Project supplier:</b>	<b>Regular CCTV:</b> <input type="checkbox"/>
<b>Client:</b> Hard Rock Ottawa L.P	<b>Reinspect with ZOOM:</b> <input type="checkbox"/>
<b>Purpose:</b> Assessment of complete remedial or renovation works	<b>Medium #:</b>
<b>Weather:</b> Dry	<b>Start position:</b>
<b>Operator:</b> RS	<b>End position:</b>
<b>Analyst:</b>	

### Internal Condition

<b>Grade:</b> 1	<b>Grade:</b> 3
<b>Total:</b> 0	<b>Total:</b> 4
<b>Peak:</b> 0	<b>Peak:</b> 2

### Operational Performance

### Comments

--

### Other information

<b>Other 1:</b> 455019	<b>Other 7:</b>
<b>Other 2:</b>	<b>Other 8:</b>
<b>Other 3:</b>	<b>Other 9:</b>
<b>Other 4:</b>	<b>Other 10:</b>
<b>Other 5:</b>	<b>PI5 (MAMR):</b>
<b>Other 6:</b>	<b>PI6 (MAMR):</b>

**#1 0.00**  
ST - Start of Survey

**#3 0.00**  
WL - Water level, 5%

**#2 0.00**  
MH - Manhole / node, MHSA-29

**#4 2.70**  
(S1) DEG - Debris grease, from 1 o'clock to 11 o'clock, 5%



**#5 3.00**  
DES - Debris silt, 5%



**#6 3.70**  
GO - General observation at this point, from 4 o'clock to 8 o'clock, robot stop by debris and rocks



**#7 3.80**  
SA - Survey abandoned, reversal not complete due to debris of rocks





### Pipe identification

<b>Pipe:</b> MHSA-30 MHSA-29	<b>Direction of inspection:</b> MHSA-30 --> MHSA-29
<b>Direction of flow:</b> MHSA-30 --> MHSA-29	<b>Direction:</b> Direction of flow

### Pipe location

<b>Road:</b> EARL ARMSTRONG	<b>City:</b> Template
<b>Crossroad:</b>	<b>Area:</b>
<b>Location:</b> Main road - Suburban/Rural	<b>Road segment:</b>

### Pipe characteristics

<b>Category:</b> Sanitary	<b>Size:</b> 250
<b>Shape:</b> Circular	<b>Width:</b>
<b>Material:</b> Polyvinyl chloride	<b>Total length:</b> 118.00
<b>Lining:</b>	<b>Pipe unit length:</b> 2.80
<b>Type:</b> Main	<b>Year laid:</b>
<b>Invert (upstream):</b>	<b>Invert (downstream):</b>
<b>Depth (upstream):</b>	<b>Depth (downstream):</b>
<b>Cover level (upstream):</b>	<b>Cover level (downstream):</b>

### Additional details

<b>Date:</b> 12/12/2018 9:32 AM	<b>Survey Abandoned:</b>
<b>Client project #:</b> Sanitary Sewer	<b>Inspected length:</b> 95.00
<b>Contractor project #:</b> HARD ROCK CASINO LP	<b>Pre-cleaning:</b> <input checked="" type="checkbox"/>
<b>Project type:</b> Video Inspection	<b>Blocked flow:</b> <input type="checkbox"/>
<b>Project supplier:</b>	<b>Regular CCTV:</b> <input type="checkbox"/>
<b>Client:</b> Hard Rock Ottawa L.P	<b>Reinspect with ZOOM:</b> <input type="checkbox"/>
<b>Purpose:</b> Assessment of complete remedial or renovation works	<b>Medium #:</b>
<b>Weather:</b> Dry	<b>Start position:</b>
<b>Operator:</b> RS	<b>End position:</b>
<b>Analyst:</b>	

### Internal Condition

<b>Grade:</b> 1	<b>Grade:</b> 3
<b>Total:</b> 0	<b>Total:</b> 8
<b>Peak:</b> 0	<b>Peak:</b> 2

### Operational Performance

### Comments

--

### Other information

<b>Other 1:</b> 455019	<b>Other 7:</b>
<b>Other 2:</b>	<b>Other 8:</b>
<b>Other 3:</b>	<b>Other 9:</b>
<b>Other 4:</b>	<b>Other 10:</b>
<b>Other 5:</b>	<b>PI5 (MAMR):</b>
<b>Other 6:</b>	<b>PI6 (MAMR):</b>

**#1 0.00**  
ST - Start of Survey

**#3 0.00**  
WL - Water level, 10%

**#2 0.00**  
MH - Manhole / node, MHSA-30

**#4 1.20**  
DEG - Debris grease, from 7 o'clock to 5 o'clock, 5%



**#5 21.30**  
DEG - Debris grease, from 7 o'clock to 5 o'clock, 5%



**#6 48.90**  
DES - Debris silt, 5%, debris underwater



**#7 95.00**  
DES - Debris silt, 15%, debris underwater block robot.



**#8 95.00**  
SA - Survey abandoned, debris underwater block robot.



### Pipe identification

<b>Pipe:</b> MHSA-31 MHSA-30	<b>Direction of inspection:</b> MHSA-31 --> MHSA-30
<b>Direction of flow:</b> MHSA-31 --> MHSA-30	<b>Direction:</b> Direction of flow

### Pipe location

<b>Road:</b> EARL ARMSTRONG	<b>City:</b> Template
<b>Crossroad:</b>	<b>Area:</b>
<b>Location:</b> Main road - Suburban/Rural	<b>Road segment:</b>

### Pipe characteristics

<b>Category:</b> Sanitary	<b>Size:</b> 250
<b>Shape:</b> Circular	<b>Width:</b>
<b>Material:</b> Polyvinyl chloride	<b>Total length:</b> 118.50
<b>Lining:</b>	<b>Pipe unit length:</b> 2.80
<b>Type:</b> Main	<b>Year laid:</b>
<b>Invert (upstream):</b>	<b>Invert (downstream):</b>
<b>Depth (upstream):</b>	<b>Depth (downstream):</b>
<b>Cover level (upstream):</b>	<b>Cover level (downstream):</b>

### Additional details

<b>Date:</b> 12/12/2018 9:18 AM	<b>Survey Abandoned:</b>
<b>Client project #:</b> Sanitary Sewer	<b>Inspected length:</b> 118.50
<b>Contractor project #:</b> HARD ROCK CASINO LP	<b>Pre-cleaning:</b> <input checked="" type="checkbox"/>
<b>Project type:</b> Video Inspection	<b>Blocked flow:</b> <input type="checkbox"/>
<b>Project supplier:</b>	<b>Regular CCTV:</b> <input type="checkbox"/>
<b>Client:</b> Hard Rock Ottawa L.P	<b>Reinspect with ZOOM:</b> <input type="checkbox"/>
<b>Purpose:</b> Assessment of complete remedial or renovation works	<b>Medium #:</b>
<b>Weather:</b> Dry	<b>Start position:</b>
<b>Operator:</b> RS	<b>End position:</b>
<b>Analyst:</b>	

### Internal Condition

<b>Grade:</b> 1	<b>Grade:</b> 3
<b>Total:</b> 0	<b>Total:</b> 4
<b>Peak:</b> 0	<b>Peak:</b> 2

### Operational Performance

### Comments

--

### Other information

<b>Other 1:</b> 455019	<b>Other 7:</b>
<b>Other 2:</b>	<b>Other 8:</b>
<b>Other 3:</b>	<b>Other 9:</b>
<b>Other 4:</b>	<b>Other 10:</b>
<b>Other 5:</b>	<b>PI5 (MAMR):</b>
<b>Other 6:</b>	<b>PI6 (MAMR):</b>

#1 0.00  
ST - Start of Survey

#3 0.00  
WL - Water level, 5%

#2 0.00  
MH - Manhole / node, MHSA-31

#4 1.60  
(S1) DEG - Debris grease, from 7 o'clock to 5 o'clock, 5%



#5 118.50  
(F1) DEG - Debris grease, from 7 o'clock to 5 o'clock, 5%



#6 118.50  
MH - Manhole / node, MHSA-30



#7 118.50  
FH - Finish of Survey



### Pipe identification

<b>Pipe:</b> MHSA-32 MHSA-31	<b>Direction of inspection:</b> MHSA-32 --> MHSA-31
<b>Direction of flow:</b> MHSA-32 --> MHSA-31	<b>Direction:</b> Direction of flow

### Pipe location

<b>Road:</b> EARL ARMSTRONG	<b>City:</b> Template
<b>Crossroad:</b> EARL ARMSTRONG	<b>Area:</b>
<b>Location:</b> Main road - Suburban/Rural	<b>Road segment:</b>

### Pipe characteristics

<b>Category:</b> Sanitary	<b>Size:</b> 250
<b>Shape:</b> Circular	<b>Width:</b>
<b>Material:</b> Polyvinyl chloride	<b>Total length:</b> 119.50
<b>Lining:</b>	<b>Pipe unit length:</b> 4.00
<b>Type:</b> Main	<b>Year laid:</b>
<b>Invert (upstream):</b>	<b>Invert (downstream):</b>
<b>Depth (upstream):</b>	<b>Depth (downstream):</b>
<b>Cover level (upstream):</b>	<b>Cover level (downstream):</b>

### Additional details

<b>Date:</b> 11/12/2018 2:54 PM	<b>Survey Abandoned:</b>
<b>Client project #:</b> Sanitary Sewer	<b>Inspected length:</b> 119.50
<b>Contractor project #:</b> HARD ROCK CASINO LP	<b>Pre-cleaning:</b> <input checked="" type="checkbox"/>
<b>Project type:</b> Video Inspection	<b>Blocked flow:</b> <input type="checkbox"/>
<b>Project supplier:</b>	<b>Regular CCTV:</b> <input type="checkbox"/>
<b>Client:</b> Hard Rock Ottawa L.P	<b>Reinspect with ZOOM:</b> <input type="checkbox"/>
<b>Purpose:</b> Assessment of complete remedial or renovation works	<b>Medium #:</b>
<b>Weather:</b> Light Snow	<b>Start position:</b>
<b>Operator:</b> RS	<b>End position:</b>
<b>Analyst:</b>	

### Internal Condition

<b>Grade:</b> 1	<b>Grade:</b> 3
<b>Total:</b> 0	<b>Total:</b> 2
<b>Peak:</b> 0	<b>Peak:</b> 2

### Operational Performance

### Comments

--

### Other information

<b>Other 1:</b> 455019	<b>Other 7:</b>
<b>Other 2:</b>	<b>Other 8:</b>
<b>Other 3:</b>	<b>Other 9:</b>
<b>Other 4:</b>	<b>Other 10:</b>
<b>Other 5:</b>	<b>PI5 (MAMR):</b>
<b>Other 6:</b>	<b>PI6 (MAMR):</b>

**#1 0.00**  
ST - Start of Survey

**#3 0.00**  
WL - Water level, 5%

**#2 0.00**  
MH - Manhole / node, MHS-32

**#4 16.80**  
DEG - Debris grease, from 1 o'clock to 12 o'clock, 5%



**#5 119.50**  
MH - Manhole / node, MHS-31



**#6 119.50**  
FH - Finish of Survey



### Pipe identification

<b>Pipe:</b> MHSA-33 MHSA-32	<b>Direction of inspection:</b> MHSA-33 --> MHSA-32
<b>Direction of flow:</b> MHSA-33 --> MHSA-32	<b>Direction:</b> Direction of flow

### Pipe location

<b>Road:</b> EARL ARMSTRONG	<b>City:</b> Template
<b>Crossroad:</b> 1ST MH WEST OF BOWESVILLE	<b>Area:</b>
<b>Location:</b> Main road - Suburban/Rural	<b>Road segment:</b>

### Pipe characteristics

<b>Category:</b> Sanitary	<b>Size:</b> 250
<b>Shape:</b> Circular	<b>Width:</b>
<b>Material:</b> Polyvinyl chloride	<b>Total length:</b> 118.00
<b>Lining:</b>	<b>Pipe unit length:</b> 4.00
<b>Type:</b> Main	<b>Year laid:</b>
<b>Invert (upstream):</b>	<b>Invert (downstream):</b>
<b>Depth (upstream):</b>	<b>Depth (downstream):</b>
<b>Cover level (upstream):</b>	<b>Cover level (downstream):</b>

### Additional details

<b>Date:</b> 11/12/2018 2:36 PM	<b>Survey Abandoned:</b>
<b>Client project #:</b> Sanitary Sewer	<b>Inspected length:</b> 118.00
<b>Contractor project #:</b> HARD ROCK CASINO LP	<b>Pre-cleaning:</b> <input checked="" type="checkbox"/>
<b>Project type:</b> Video Inspection	<b>Blocked flow:</b> <input type="checkbox"/>
<b>Project supplier:</b>	<b>Regular CCTV:</b> <input type="checkbox"/>
<b>Client:</b> Hard Rock Ottawa L.P	<b>Reinspect with ZOOM:</b> <input type="checkbox"/>
<b>Purpose:</b> Assessment of complete remedial or renovation works	<b>Medium #:</b>
<b>Weather:</b> Light Snow	<b>Start position:</b>
<b>Operator:</b> RS	<b>End position:</b>
<b>Analyst:</b>	

### Internal Condition

<b>Grade:</b> 1
<b>Total:</b> 0
<b>Peak:</b> 0

### Operational Performance

<b>Grade:</b> 1
<b>Total:</b> 0
<b>Peak:</b> 0

### Comments

--

### Other information

<b>Other 1:</b> 455019	<b>Other 7:</b>
<b>Other 2:</b>	<b>Other 8:</b>
<b>Other 3:</b>	<b>Other 9:</b>
<b>Other 4:</b>	<b>Other 10:</b>
<b>Other 5:</b>	<b>PI5 (MAMR):</b>
<b>Other 6:</b>	<b>PI6 (MAMR):</b>

**#1 0.00**  
ST - Start of Survey

**#3 0.00**  
WL - Water level, 5%

**#2 0.00**  
MH - Manhole / node, MHSA-33

**#4 118.00**  
MH - Manhole / node, MHSA-32



**#5 118.00**  
FH - Finish of Survey





### Pipe identification

<b>Pipe:</b> MHSA-33 MHSA-34	<b>Direction of inspection:</b> MHSA-33 --> MHSA-34
<b>Direction of flow:</b> MHSA-34 --> MHSA-33	<b>Direction:</b> Against flow

### Pipe location

<b>Road:</b> EARL ARMSTRONG	<b>City:</b> Template
<b>Crossroad:</b> 1ST MH WEST OF BOWESVILLE	<b>Area:</b>
<b>Location:</b> Main road - Suburban/Rural	<b>Road segment:</b>

### Pipe characteristics

<b>Category:</b> Sanitary	<b>Size:</b> 250
<b>Shape:</b> Circular	<b>Width:</b>
<b>Material:</b> Polyvinyl chloride	<b>Total length:</b> 119.00
<b>Lining:</b>	<b>Pipe unit length:</b> 4.00
<b>Type:</b> Main	<b>Year laid:</b>
<b>Invert (upstream):</b>	<b>Invert (downstream):</b>
<b>Depth (upstream):</b>	<b>Depth (downstream):</b>
<b>Cover level (upstream):</b>	<b>Cover level (downstream):</b>

### Additional details

<b>Date:</b> 11/12/2018 2:09 PM	<b>Survey Abandoned:</b>
<b>Client project #:</b> Sanitary Sewer	<b>Inspected length:</b> 119.00
<b>Contractor project #:</b> HARD ROCK CASINO LP	<b>Pre-cleaning:</b> <input checked="" type="checkbox"/>
<b>Project type:</b> Video Inspection	<b>Blocked flow:</b> <input type="checkbox"/>
<b>Project supplier:</b>	<b>Regular CCTV:</b> <input type="checkbox"/>
<b>Client:</b> Hard Rock Ottawa L.P	<b>Reinspect with ZOOM:</b> <input type="checkbox"/>
<b>Purpose:</b> Assessment of complete remedial or renovation works	<b>Medium #:</b>
<b>Weather:</b> Dry	<b>Start position:</b>
<b>Operator:</b> RS	<b>End position:</b>
<b>Analyst:</b>	

### Internal Condition

<b>Grade:</b> 1	<b>Grade:</b> 3
<b>Total:</b> 0	<b>Total:</b> 2
<b>Peak:</b> 0	<b>Peak:</b> 2

### Operational Performance

### Comments

--

### Other information

<b>Other 1:</b> 455019	<b>Other 7:</b>
<b>Other 2:</b>	<b>Other 8:</b>
<b>Other 3:</b>	<b>Other 9:</b>
<b>Other 4:</b>	<b>Other 10:</b>
<b>Other 5:</b>	<b>PI5 (MAMR):</b>
<b>Other 6:</b>	<b>PI6 (MAMR):</b>

#1 0.00  
ST - Start of Survey

#3 0.00  
WL - Water level, 5%

#2 0.00  
MH - Manhole / node, MHSA-33

#4 106.10  
(S1) DEG - Debris grease, from 5 o'clock to 7 o'clock, 5%



#5 119.00  
MH - Manhole / node, MHSA-34



#6 119.00  
FH - Finish of Survey



### Pipe identification

<b>Pipe:</b> MHSA-35 MHSA-34	<b>Direction of inspection:</b> MHSA-35 --> MHSA-34
<b>Direction of flow:</b> MHSA-35 --> MHSA-34	<b>Direction:</b> Direction of flow

### Pipe location

<b>Road:</b> EARL ARMSTRONG	<b>City:</b> Template
<b>Crossroad:</b> BOWESVILLE	<b>Area:</b>
<b>Location:</b> Main road - Urban	<b>Road segment:</b>

### Pipe characteristics

<b>Category:</b> Sanitary	<b>Size:</b> 250
<b>Shape:</b> Circular	<b>Width:</b>
<b>Material:</b> Polyvinyl chloride	<b>Total length:</b> 52.00
<b>Lining:</b>	<b>Pipe unit length:</b> 4.00
<b>Type:</b> Main	<b>Year laid:</b>
<b>Invert (upstream):</b>	<b>Invert (downstream):</b>
<b>Depth (upstream):</b>	<b>Depth (downstream):</b>
<b>Cover level (upstream):</b>	<b>Cover level (downstream):</b>

### Additional details

<b>Date:</b> 11/12/2018 1:24 PM	<b>Survey Abandoned:</b>
<b>Client project #:</b> Sanitary Sewer	<b>Inspected length:</b> 52.00
<b>Contractor project #:</b> HARD ROCK CASINO LP	<b>Pre-cleaning:</b> <input checked="" type="checkbox"/>
<b>Project type:</b> Video Inspection	<b>Blocked flow:</b> <input type="checkbox"/>
<b>Project supplier:</b>	<b>Regular CCTV:</b> <input type="checkbox"/>
<b>Client:</b> Hard Rock Ottawa L.P	<b>Reinspect with ZOOM:</b> <input type="checkbox"/>
<b>Purpose:</b> Assessment of complete remedial or renovation works	<b>Medium #:</b>
<b>Weather:</b> Light Snow	<b>Start position:</b>
<b>Operator:</b> RS	<b>End position:</b>
<b>Analyst:</b>	

### Internal Condition

<b>Grade:</b> 1	<b>Grade:</b> 1
<b>Total:</b> 0	<b>Total:</b> 0
<b>Peak:</b> 0	<b>Peak:</b> 0

### Operational Performance

### Comments

--

### Other information

<b>Other 1:</b> 455019	<b>Other 7:</b>
<b>Other 2:</b>	<b>Other 8:</b>
<b>Other 3:</b>	<b>Other 9:</b>
<b>Other 4:</b>	<b>Other 10:</b>
<b>Other 5:</b>	<b>PI5 (MAMR):</b>
<b>Other 6:</b>	<b>PI6 (MAMR):</b>

**#1 0.00**  
ST - Start of Survey

**#3 0.00**  
WL - Water level, 5%

**#2 0.00**  
MH - Manhole / node, MHSA-35

**#4 52.00**  
MH - Manhole / node, MHSA-34



**#5 52.00**  
FH - Finish of Survey



### Pipe identification

<b>Pipe:</b> MHSA-36 MHSA-35	<b>Direction of inspection:</b> MHSA-36 --> MHSA-35
<b>Direction of flow:</b> MHSA-36 --> MHSA-35	<b>Direction:</b> Direction of flow

### Pipe location

<b>Road:</b> EARL ARMSTRONG	<b>City:</b> Template
<b>Crossroad:</b> EARL ARMSTRONG	<b>Area:</b>
<b>Location:</b> Main road - Suburban/Rural	<b>Road segment:</b>

### Pipe characteristics

<b>Category:</b> Sanitary	<b>Size:</b> 250
<b>Shape:</b> Circular	<b>Width:</b>
<b>Material:</b> Polyvinyl chloride	<b>Total length:</b> 118.50
<b>Lining:</b>	<b>Pipe unit length:</b> 4.00
<b>Type:</b> Main	<b>Year laid:</b>
<b>Invert (upstream):</b>	<b>Invert (downstream):</b>
<b>Depth (upstream):</b>	<b>Depth (downstream):</b>
<b>Cover level (upstream):</b>	<b>Cover level (downstream):</b>

### Additional details

<b>Date:</b> 11/12/2018 1:04 PM	<b>Survey Abandoned:</b>
<b>Client project #:</b> Sanitary Sewer	<b>Inspected length:</b> 118.50
<b>Contractor project #:</b> HARD ROCK CASINO LP	<b>Pre-cleaning:</b> <input checked="" type="checkbox"/>
<b>Project type:</b> Video Inspection	<b>Blocked flow:</b> <input type="checkbox"/>
<b>Project supplier:</b>	<b>Regular CCTV:</b> <input type="checkbox"/>
<b>Client:</b> Hard Rock Ottawa L.P	<b>Reinspect with ZOOM:</b> <input type="checkbox"/>
<b>Purpose:</b> Assessment of complete remedial or renovation works	<b>Medium #:</b>
<b>Weather:</b> Light Snow	<b>Start position:</b>
<b>Operator:</b> RS	<b>End position:</b>
<b>Analyst:</b>	

### Internal Condition

<b>Grade:</b> 1	<b>Grade:</b> 1
<b>Total:</b> 0	<b>Total:</b> 0
<b>Peak:</b> 0	<b>Peak:</b> 0

### Operational Performance

### Comments

--

### Other information

<b>Other 1:</b> 455019	<b>Other 7:</b>
<b>Other 2:</b>	<b>Other 8:</b>
<b>Other 3:</b>	<b>Other 9:</b>
<b>Other 4:</b>	<b>Other 10:</b>
<b>Other 5:</b>	<b>PI5 (MAMR):</b>
<b>Other 6:</b>	<b>PI6 (MAMR):</b>

**#1 0.00**  
ST - Start of Survey

**#3 0.00**  
WL - Water level, 5%

**#2 0.00**  
MH - Manhole / node, MHSА-36

**#4 118.50**  
GO - General observation at this point,  
from 1 o'clock to 12 o'clock, MHSА-35 IS AT  
BOWESVILLE



**#5 118.50**  
MH - Manhole / node, MHSА-35



**#6 118.50**  
FH - Finish of Survey



### Pipe identification

<b>Pipe:</b> MHSA-37. MHSA-36.	<b>Direction of inspection:</b> MHSA-37. --> MHSA-36.
<b>Direction of flow:</b> MHSA-37. --> MHSA-36.	<b>Direction:</b> Direction of flow

### Pipe location

<b>Road:</b> EARL ARMSTRONG	<b>City:</b> Template
<b>Crossroad:</b>	<b>Area:</b>
<b>Location:</b> Main road - Suburban/Rural	<b>Road segment:</b>

### Pipe characteristics

<b>Category:</b> Sanitary	<b>Size:</b> 250
<b>Shape:</b> Circular	<b>Width:</b>
<b>Material:</b> Polyvinyl chloride	<b>Total length:</b> 119.00
<b>Lining:</b>	<b>Pipe unit length:</b> 2.80
<b>Type:</b> Main	<b>Year laid:</b>
<b>Invert (upstream):</b>	<b>Invert (downstream):</b>
<b>Depth (upstream):</b>	<b>Depth (downstream):</b>
<b>Cover level (upstream):</b>	<b>Cover level (downstream):</b>

### Additional details

<b>Date:</b> 12/12/2018 10:55 AM	<b>Survey Abandoned:</b>
<b>Client project #:</b> Sanitary Sewer	<b>Inspected length:</b> 119.00
<b>Contractor project #:</b> HARD ROCK CASINO LP	<b>Pre-cleaning:</b> <input checked="" type="checkbox"/>
<b>Project type:</b> Video Inspection	<b>Blocked flow:</b> <input type="checkbox"/>
<b>Project supplier:</b>	<b>Regular CCTV:</b> <input type="checkbox"/>
<b>Client:</b> Hard Rock Ottawa L.P	<b>Reinspect with ZOOM:</b> <input type="checkbox"/>
<b>Purpose:</b> Assessment of complete remedial or renovation works	<b>Medium #:</b>
<b>Weather:</b> Dry	<b>Start position:</b>
<b>Operator:</b> RS	<b>End position:</b>
<b>Analyst:</b>	

### Internal Condition

<b>Grade:</b> 1	<b>Grade:</b> 1
<b>Total:</b> 0	<b>Total:</b> 0
<b>Peak:</b> 0	<b>Peak:</b> 0

### Operational Performance

### Comments

--

### Other information

<b>Other 1:</b> 455019	<b>Other 7:</b>
<b>Other 2:</b>	<b>Other 8:</b>
<b>Other 3:</b>	<b>Other 9:</b>
<b>Other 4:</b>	<b>Other 10:</b>
<b>Other 5:</b>	<b>PI5 (MAMR):</b>
<b>Other 6:</b>	<b>PI6 (MAMR):</b>

**#1 0.00**  
ST - Start of Survey

**#3 0.00**  
WL - Water level, 5%

**#2 0.00**  
MH - Manhole / node, MHSA-37.

**#4 119.00**  
MH - Manhole / node, MHSA-36.

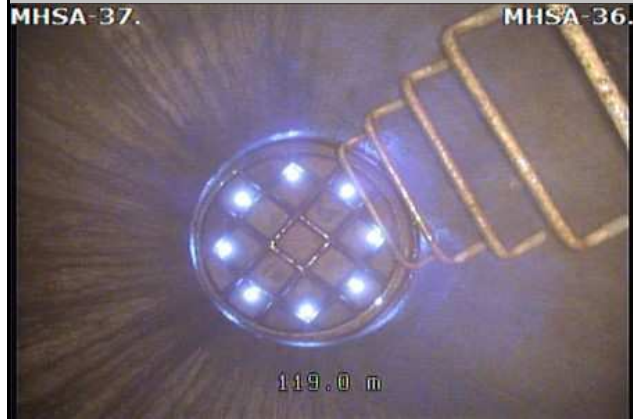

**#5 119.00**  
FH - Finish of Survey





### Pipe identification

<b>Pipe:</b> MHSA-38 MHSA-37	<b>Direction of inspection:</b> MHSA-38 --> MHSA-37
<b>Direction of flow:</b> MHSA-38 --> MHSA-37	<b>Direction:</b> Direction of flow

### Pipe location

<b>Road:</b> EARL ARMSTRONG	<b>City:</b> Template
<b>Crossroad:</b> EARL ARMSTRONG	<b>Area:</b>
<b>Location:</b> Main road - Suburban/Rural	<b>Road segment:</b>

### Pipe characteristics

<b>Category:</b> Sanitary	<b>Size:</b> 250
<b>Shape:</b> Circular	<b>Width:</b>
<b>Material:</b> Polyvinyl chloride	<b>Total length:</b> 118.00
<b>Lining:</b>	<b>Pipe unit length:</b> 4.00
<b>Type:</b> Main	<b>Year laid:</b>
<b>Invert (upstream):</b>	<b>Invert (downstream):</b>
<b>Depth (upstream):</b>	<b>Depth (downstream):</b>
<b>Cover level (upstream):</b>	<b>Cover level (downstream):</b>

### Additional details

<b>Date:</b> 11/12/2018 11:47 AM	<b>Survey Abandoned:</b>
<b>Client project #:</b> Sanitary Sewer	<b>Inspected length:</b> 118.00
<b>Contractor project #:</b> HARD ROCK CASINO LP	<b>Pre-cleaning:</b> <input checked="" type="checkbox"/>
<b>Project type:</b> Video Inspection	<b>Blocked flow:</b> <input type="checkbox"/>
<b>Project supplier:</b>	<b>Regular CCTV:</b> <input type="checkbox"/>
<b>Client:</b> Hard Rock Ottawa L.P	<b>Reinspect with ZOOM:</b> <input type="checkbox"/>
<b>Purpose:</b> Assessment of complete remedial or renovation works	<b>Medium #:</b>
<b>Weather:</b> Light Snow	<b>Start position:</b>
<b>Operator:</b> RS	<b>End position:</b>
<b>Analyst:</b>	

### Internal Condition

<b>Grade:</b> 1	<b>Grade:</b> 1
<b>Total:</b> 0	<b>Total:</b> 0
<b>Peak:</b> 0	<b>Peak:</b> 0

### Operational Performance

### Comments

--

### Other information

<b>Other 1:</b> 455019	<b>Other 7:</b>
<b>Other 2:</b>	<b>Other 8:</b>
<b>Other 3:</b>	<b>Other 9:</b>
<b>Other 4:</b>	<b>Other 10:</b>
<b>Other 5:</b>	<b>PI5 (MAMR):</b>
<b>Other 6:</b>	<b>PI6 (MAMR):</b>

**#1 0.00**  
ST - Start of Survey

**#3 0.00**  
WL - Water level, 5%

**#2 0.00**  
MH - Manhole / node, MHSA-38

**#4 118.00**  
MH - Manhole / node, MHSA-37



**#5 118.00**  
FH - Finish of Survey



### Pipe identification

<b>Pipe:</b> MHSA-39 MHSA-38	<b>Direction of inspection:</b> MHSA-39 --> MHSA-38
<b>Direction of flow:</b> MHSA-39 --> MHSA-38	<b>Direction:</b> Direction of flow

### Pipe location

<b>Road:</b> EARL ARMSTRONG	<b>City:</b> Template
<b>Crossroad:</b> 2220 EARL ARMSTRONG	<b>Area:</b>
<b>Location:</b> Main road - Suburban/Rural	<b>Road segment:</b>

### Pipe characteristics

<b>Category:</b> Sanitary	<b>Size:</b> 250
<b>Shape:</b> Circular	<b>Width:</b>
<b>Material:</b> Polyvinyl chloride	<b>Total length:</b> 118.00
<b>Lining:</b>	<b>Pipe unit length:</b> 4.00
<b>Type:</b> Main	<b>Year laid:</b>
<b>Invert (upstream):</b>	<b>Invert (downstream):</b>
<b>Depth (upstream):</b>	<b>Depth (downstream):</b>
<b>Cover level (upstream):</b>	<b>Cover level (downstream):</b>

### Additional details

<b>Date:</b> 11/12/2018 11:25 AM	<b>Survey Abandoned:</b>
<b>Client project #:</b> Sanitary Sewer	<b>Inspected length:</b> 118.00
<b>Contractor project #:</b> HARD ROCK CASINO LP	<b>Pre-cleaning:</b> <input checked="" type="checkbox"/>
<b>Project type:</b> Video Inspection	<b>Blocked flow:</b> <input type="checkbox"/>
<b>Project supplier:</b>	<b>Regular CCTV:</b> <input type="checkbox"/>
<b>Client:</b> Hard Rock Ottawa L.P	<b>Reinspect with ZOOM:</b> <input type="checkbox"/>
<b>Purpose:</b> Assessment of complete remedial or renovation works	<b>Medium #:</b>
<b>Weather:</b> Light Snow	<b>Start position:</b>
<b>Operator:</b> RS	<b>End position:</b>
<b>Analyst:</b>	

### Internal Condition

<b>Grade:</b> 1	<b>Grade:</b> 3
<b>Total:</b> 0	<b>Total:</b> 12
<b>Peak:</b> 0	<b>Peak:</b> 2

### Operational Performance

### Comments

--

### Other information

<b>Other 1:</b> 455019	<b>Other 7:</b>
<b>Other 2:</b>	<b>Other 8:</b>
<b>Other 3:</b>	<b>Other 9:</b>
<b>Other 4:</b>	<b>Other 10:</b>
<b>Other 5:</b>	<b>PI5 (MAMR):</b>
<b>Other 6:</b>	<b>PI6 (MAMR):</b>

**#1 0.00**  
ST - Start of Survey

**#3 0.00**  
WL - Water level, 5%

**#2 0.00**  
MH - Manhole / node, MHSA-39

**#4 70.20**  
DE - Debris (non-silt / grease), 5%



**#5 73.20**  
DEG - Debris grease, from 11 o'clock to 12 o'clock, 5%



**#6 79.30**  
(S1) DEG - Debris grease, from 11 o'clock to 1 o'clock, 5%



**#7 82.00**  
(F1) DEG - Debris grease, from 11 o'clock to 1 o'clock, 0%

**#8 87.00**  
(S2) DEG - Debris grease, from 11 o'clock to 1 o'clock, 5%





### Pipe identification

<b>Pipe:</b> MHSA-40 MHSA-39	<b>Direction of inspection:</b> MHSA-40 --> MHSA-39
<b>Direction of flow:</b> MHSA-40 --> MHSA-39	<b>Direction:</b> Direction of flow

### Pipe location

<b>Road:</b> EARL ARMSTRONG	<b>City:</b> Template
<b>Crossroad:</b> EARL ARMSTRONG	<b>Area:</b>
<b>Location:</b> Main road - Suburban/Rural	<b>Road segment:</b>

### Pipe characteristics

<b>Category:</b> Sanitary	<b>Size:</b> 250
<b>Shape:</b> Circular	<b>Width:</b>
<b>Material:</b> Polyvinyl chloride	<b>Total length:</b> 118.50
<b>Lining:</b>	<b>Pipe unit length:</b> 4.00
<b>Type:</b> Main	<b>Year laid:</b>
<b>Invert (upstream):</b>	<b>Invert (downstream):</b>
<b>Depth (upstream):</b>	<b>Depth (downstream):</b>
<b>Cover level (upstream):</b>	<b>Cover level (downstream):</b>

### Additional details

<b>Date:</b> 11/12/2018 10:50 AM	<b>Survey Abandoned:</b>
<b>Client project #:</b> Sanitary Sewer	<b>Inspected length:</b> 118.50
<b>Contractor project #:</b> HARD ROCK CASINO LP	<b>Pre-cleaning:</b> <input checked="" type="checkbox"/>
<b>Project type:</b> Video Inspection	<b>Blocked flow:</b> <input type="checkbox"/>
<b>Project supplier:</b>	<b>Regular CCTV:</b> <input type="checkbox"/>
<b>Client:</b> Hard Rock Ottawa L.P	<b>Reinspect with ZOOM:</b> <input type="checkbox"/>
<b>Purpose:</b> Assessment of complete remedial or renovation works	<b>Medium #:</b>
<b>Weather:</b> Light Snow	<b>Start position:</b>
<b>Operator:</b> RS	<b>End position:</b>
<b>Analyst:</b>	

### Internal Condition

<b>Grade:</b> 1	<b>Grade:</b> 1
<b>Total:</b> 0	<b>Total:</b> 0
<b>Peak:</b> 0	<b>Peak:</b> 0

### Operational Performance

### Comments

--

### Other information

<b>Other 1:</b> 455019	<b>Other 7:</b>
<b>Other 2:</b>	<b>Other 8:</b>
<b>Other 3:</b>	<b>Other 9:</b>
<b>Other 4:</b>	<b>Other 10:</b>
<b>Other 5:</b>	<b>PI5 (MAMR):</b>
<b>Other 6:</b>	<b>PI6 (MAMR):</b>

**#1 0.00**  
ST - Start of Survey

**#3 0.00**  
WL - Water level, 10%

**#2 0.00**  
MH - Manhole / node, MHSA-40

**#4 118.50**  
MH - Manhole / node, MHSA-39



**#5 118.50**  
FH - Finish of Survey



### Pipe identification

<b>Pipe:</b> MHSA-41 MHSA-40	<b>Direction of inspection:</b> MHSA-41 --> MHSA-40
<b>Direction of flow:</b> MHSA-41 --> MHSA-40	<b>Direction:</b> Direction of flow

### Pipe location

<b>Road:</b> EARL ARMSTRONG	<b>City:</b> Template
<b>Crossroad:</b> AT BICYCLE PATH	<b>Area:</b>
<b>Location:</b> Main road - Suburban/Rural	<b>Road segment:</b>

### Pipe characteristics

<b>Category:</b> Sanitary	<b>Size:</b> 250
<b>Shape:</b> Circular	<b>Width:</b>
<b>Material:</b> Polyvinyl chloride	<b>Total length:</b> 118.50
<b>Lining:</b>	<b>Pipe unit length:</b> 4.00
<b>Type:</b> Main	<b>Year laid:</b>
<b>Invert (upstream):</b>	<b>Invert (downstream):</b>
<b>Depth (upstream):</b>	<b>Depth (downstream):</b>
<b>Cover level (upstream):</b>	<b>Cover level (downstream):</b>

### Additional details

<b>Date:</b> 11/12/2018 10:29 AM	<b>Survey Abandoned:</b>
<b>Client project #:</b> Sanitary Sewer	<b>Inspected length:</b> 118.50
<b>Contractor project #:</b> HARD ROCK CASINO LP	<b>Pre-cleaning:</b> <input checked="" type="checkbox"/>
<b>Project type:</b> Video Inspection	<b>Blocked flow:</b> <input type="checkbox"/>
<b>Project supplier:</b>	<b>Regular CCTV:</b> <input type="checkbox"/>
<b>Client:</b> Hard Rock Ottawa L.P	<b>Reinspect with ZOOM:</b> <input type="checkbox"/>
<b>Purpose:</b> Assessment of complete remedial or renovation works	<b>Medium #:</b>
<b>Weather:</b> Light Snow	<b>Start position:</b>
<b>Operator:</b> RS	<b>End position:</b>
<b>Analyst:</b>	

### Internal Condition

<b>Grade:</b> 1	<b>Grade:</b> 1
<b>Total:</b> 0	<b>Total:</b> 0
<b>Peak:</b> 0	<b>Peak:</b> 0

### Operational Performance

### Comments

--

### Other information

<b>Other 1:</b> 455019	<b>Other 7:</b>
<b>Other 2:</b>	<b>Other 8:</b>
<b>Other 3:</b>	<b>Other 9:</b>
<b>Other 4:</b>	<b>Other 10:</b>
<b>Other 5:</b>	<b>PI5 (MAMR):</b>
<b>Other 6:</b>	<b>PI6 (MAMR):</b>



**#1 0.00**  
ST - Start of Survey

**#3 0.00**  
WL - Water level, 5%

**#2 0.00**  
MH - Manhole / node, MHSA-41

**#4 118.50**  
MH - Manhole / node, MHSA-40



**#5 118.50**  
FH - Finish of Survey



### Pipe identification

<b>Pipe:</b> MHSA-42 MHSA-41	<b>Direction of inspection:</b> MHSA-42 --> MHSA-41
<b>Direction of flow:</b> MHSA-42 --> MHSA-41	<b>Direction:</b> Direction of flow

### Pipe location

<b>Road:</b> EARL ARMSTRONG	<b>City:</b> Template
<b>Crossroad:</b>	<b>Area:</b>
<b>Location:</b> Main road - Suburban/Rural	<b>Road segment:</b>

### Pipe characteristics

<b>Category:</b> Sanitary	<b>Size:</b> 250
<b>Shape:</b> Circular	<b>Width:</b>
<b>Material:</b> Polyvinyl chloride	<b>Total length:</b> 118.00
<b>Lining:</b>	<b>Pipe unit length:</b> 2.80
<b>Type:</b> Main	<b>Year laid:</b>
<b>Invert (upstream):</b>	<b>Invert (downstream):</b>
<b>Depth (upstream):</b>	<b>Depth (downstream):</b>
<b>Cover level (upstream):</b>	<b>Cover level (downstream):</b>

### Additional details

<b>Date:</b> 06/12/2018 11:01 AM	<b>Survey Abandoned:</b>
<b>Client project #:</b> Sanitary Sewer	<b>Inspected length:</b> 18.00
<b>Contractor project #:</b> HARD ROCK CASINO LP	<b>Pre-cleaning:</b> <input checked="" type="checkbox"/>
<b>Project type:</b> Video Inspection	<b>Blocked flow:</b> <input type="checkbox"/>
<b>Project supplier:</b>	<b>Regular CCTV:</b> <input type="checkbox"/>
<b>Client:</b> Hard Rock Ottawa L.P	<b>Reinspect with ZOOM:</b> <input type="checkbox"/>
<b>Purpose:</b> Assessment of complete remedial or renovation works	<b>Medium #:</b>
<b>Weather:</b> Snow	<b>Start position:</b>
<b>Operator:</b> RS	<b>End position:</b>
<b>Analyst:</b>	

### Internal Condition

<b>Grade:</b> 1	<b>Grade:</b> 3
<b>Total:</b> 0	<b>Total:</b> 2
<b>Peak:</b> 0	<b>Peak:</b> 2

### Operational Performance

### Comments

--

### Other information

<b>Other 1:</b> 45-5019	<b>Other 7:</b>
<b>Other 2:</b>	<b>Other 8:</b>
<b>Other 3:</b>	<b>Other 9:</b>
<b>Other 4:</b>	<b>Other 10:</b>
<b>Other 5:</b>	<b>PI5 (MAMR):</b>
<b>Other 6:</b>	<b>PI6 (MAMR):</b>

#1

### Pipe identification

<b>Pipe:</b> MHSA-42 MHSA-43	<b>Direction of inspection:</b> MHSA-42 --> MHSA-43
<b>Direction of flow:</b> MHSA-43 --> MHSA-42	<b>Direction:</b> Against flow

### Pipe location

<b>Road:</b> EARL ARMSTRONG	<b>City:</b> Template
<b>Crossroad:</b> HIGH RD	<b>Area:</b>
<b>Location:</b> Main road - Suburban/Rural	<b>Road segment:</b>

### Pipe characteristics

<b>Category:</b> Sanitary	<b>Size:</b> 250
<b>Shape:</b> Circular	<b>Width:</b>
<b>Material:</b> Polyvinyl chloride	<b>Total length:</b> 120.00
<b>Lining:</b>	<b>Pipe unit length:</b> 2.80
<b>Type:</b> Main	<b>Year laid:</b>
<b>Invert (upstream):</b>	<b>Invert (downstream):</b>
<b>Depth (upstream):</b>	<b>Depth (downstream):</b>
<b>Cover level (upstream):</b>	<b>Cover level (downstream):</b>

### Additional details

<b>Date:</b> 06/12/2018 10:45 AM	<b>Survey Abandoned:</b>
<b>Client project #:</b> Sanitary Sewer	<b>Inspected length:</b> 16.10
<b>Contractor project #:</b> HARD ROCK CASINO LP	<b>Pre-cleaning:</b> <input checked="" type="checkbox"/>
<b>Project type:</b> Video Inspection	<b>Blocked flow:</b> <input type="checkbox"/>
<b>Project supplier:</b>	<b>Regular CCTV:</b> <input type="checkbox"/>
<b>Client:</b> Hard Rock Ottawa L.P	<b>Reinspect with ZOOM:</b> <input type="checkbox"/>
<b>Purpose:</b> Assessment of complete remedial or renovation works	<b>Medium #:</b>
<b>Weather:</b> Snow	<b>Start position:</b>
<b>Operator:</b> RS	<b>End position:</b>
<b>Analyst:</b>	

### Internal Condition

<b>Grade:</b> 1	<b>Grade:</b> 1
<b>Total:</b> 0	<b>Total:</b> 0
<b>Peak:</b> 0	<b>Peak:</b> 0

### Operational Performance

### Comments

--

### Other information

<b>Other 1:</b> 45-5019	<b>Other 7:</b>
<b>Other 2:</b>	<b>Other 8:</b>
<b>Other 3:</b>	<b>Other 9:</b>
<b>Other 4:</b>	<b>Other 10:</b>
<b>Other 5:</b>	<b>PI5 (MAMR):</b>
<b>Other 6:</b>	<b>PI6 (MAMR):</b>

**#1 0.00**  
ST - Start of Survey

**#3 0.00**  
WL - Water level, 5%

**#2 0.00**  
MH - Manhole / node, MHSA-42

**#4 16.10**  
GO - General observation at this point, reversal overlap



**#5 16.10**  
SA - Survey abandoned, reversal complete



### Pipe identification

<b>Pipe:</b> MHSA-43 MHSA-42	<b>Direction of inspection:</b> MHSA-43 --> MHSA-42
<b>Direction of flow:</b> MHSA-43 --> MHSA-42	<b>Direction:</b> Direction of flow

### Pipe location

<b>Road:</b> EARL ARMSTRONG	<b>City:</b> Template
<b>Crossroad:</b>	<b>Area:</b>
<b>Location:</b> Main road - Suburban/Rural	<b>Road segment:</b>

### Pipe characteristics

<b>Category:</b> Sanitary	<b>Size:</b> 250
<b>Shape:</b> Circular	<b>Width:</b>
<b>Material:</b> Polyvinyl chloride	<b>Total length:</b> 120.00
<b>Lining:</b>	<b>Pipe unit length:</b> 2.80
<b>Type:</b> Main	<b>Year laid:</b>
<b>Invert (upstream):</b>	<b>Invert (downstream):</b>
<b>Depth (upstream):</b>	<b>Depth (downstream):</b>
<b>Cover level (upstream):</b>	<b>Cover level (downstream):</b>

### Additional details

<b>Date:</b> 06/12/2018 8:32 AM	<b>Survey Abandoned:</b>
<b>Client project #:</b> Sanitary Sewer	<b>Inspected length:</b> 106.40
<b>Contractor project #:</b> HARD ROCK CASINO LP	<b>Pre-cleaning:</b> <input checked="" type="checkbox"/>
<b>Project type:</b> Video Inspection	<b>Blocked flow:</b> <input type="checkbox"/>
<b>Project supplier:</b>	<b>Regular CCTV:</b> <input type="checkbox"/>
<b>Client:</b> Hard Rock Ottawa L.P	<b>Reinspect with ZOOM:</b> <input type="checkbox"/>
<b>Purpose:</b> Assessment of complete remedial or renovation works	<b>Medium #:</b>
<b>Weather:</b> Snow	<b>Start position:</b>
<b>Operator:</b> RS	<b>End position:</b>
<b>Analyst:</b>	

### Internal Condition

<b>Grade:</b> 1	<b>Grade:</b> 1
<b>Total:</b> 0	<b>Total:</b> 0
<b>Peak:</b> 0	<b>Peak:</b> 0

### Operational Performance

### Comments

--

### Other information

<b>Other 1:</b> 45-5019	<b>Other 7:</b>
<b>Other 2:</b>	<b>Other 8:</b>
<b>Other 3:</b>	<b>Other 9:</b>
<b>Other 4:</b>	<b>Other 10:</b>
<b>Other 5:</b>	<b>PI5 (MAMR):</b>
<b>Other 6:</b>	<b>PI6 (MAMR):</b>

#1 0.00  
ST - Start of Survey

#3 0.00  
WL - Water level, 5%

#2 0.00  
MH - Manhole / node, MHSA-43

#4 106.40  
SA - Survey abandoned, track spinning on grease



#5 106.90  
GO - General observation at this point, from 5 o'clock to 7 o'clock, track spinning on grease



### Pipe identification

<b>Pipe:</b> MHSA-44 MHSA-43	<b>Direction of inspection:</b> MHSA-44 --> MHSA-43
<b>Direction of flow:</b> MHSA-44 --> MHSA-43	<b>Direction:</b> Direction of flow

### Pipe location

<b>Road:</b> EARL ARMSTRONG	<b>City:</b> Template
<b>Crossroad:</b>	<b>Area:</b>
<b>Location:</b> Main road - Suburban/Rural	<b>Road segment:</b>

### Pipe characteristics

<b>Category:</b> Sanitary	<b>Size:</b> 250
<b>Shape:</b> Circular	<b>Width:</b>
<b>Material:</b> Polyvinyl chloride	<b>Total length:</b> 119.00
<b>Lining:</b>	<b>Pipe unit length:</b> 2.80
<b>Type:</b> Main	<b>Year laid:</b>
<b>Invert (upstream):</b>	<b>Invert (downstream):</b>
<b>Depth (upstream):</b>	<b>Depth (downstream):</b>
<b>Cover level (upstream):</b>	<b>Cover level (downstream):</b>

### Additional details

<b>Date:</b> 05/12/2018 11:41 AM	<b>Survey Abandoned:</b>
<b>Client project #:</b> Sanitary Sewer	<b>Inspected length:</b> 119.00
<b>Contractor project #:</b> HARD ROCK CASINO LP	<b>Pre-cleaning:</b> <input checked="" type="checkbox"/>
<b>Project type:</b> Video Inspection	<b>Blocked flow:</b> <input type="checkbox"/>
<b>Project supplier:</b>	<b>Regular CCTV:</b> <input type="checkbox"/>
<b>Client:</b> Hard Rock Ottawa L.P	<b>Reinspect with ZOOM:</b> <input type="checkbox"/>
<b>Purpose:</b> Assessment of complete remedial or renovation works	<b>Medium #:</b>
<b>Weather:</b> Light Snow	<b>Start position:</b>
<b>Operator:</b> RS	<b>End position:</b>
<b>Analyst:</b>	

### Internal Condition

<b>Grade:</b> 1	<b>Grade:</b> 3
<b>Total:</b> 0	<b>Total:</b> 2
<b>Peak:</b> 0	<b>Peak:</b> 2

### Operational Performance

### Comments

--

### Other information

<b>Other 1:</b> 45-5019	<b>Other 7:</b>
<b>Other 2:</b>	<b>Other 8:</b>
<b>Other 3:</b>	<b>Other 9:</b>
<b>Other 4:</b>	<b>Other 10:</b>
<b>Other 5:</b>	<b>PI5 (MAMR):</b>
<b>Other 6:</b>	<b>PI6 (MAMR):</b>



**#1 0.00**  
ST - Start of Survey

**#3 0.00**  
WL - Water level, 5%

**#2 0.00**  
MH - Manhole / node, MHS-44

**#4 65.10**  
(S1) DEG - Debris grease, from 7 o'clock to 5 o'clock, 5%



**#5 119.00**  
MH - Manhole / node, MHS-43



**#6 119.00**  
FH - Finish of Survey



### Pipe identification

<b>Pipe:</b> MHSA-44 MHSA-45	<b>Direction of inspection:</b> MHSA-44 --> MHSA-45
<b>Direction of flow:</b> MHSA-45 --> MHSA-44	<b>Direction:</b> Against flow

### Pipe location

<b>Road:</b> EARL ARMSTRONG	<b>City:</b> Template
<b>Crossroad:</b>	<b>Area:</b>
<b>Location:</b> Main road - Suburban/Rural	<b>Road segment:</b>

### Pipe characteristics

<b>Category:</b> Sanitary	<b>Size:</b> 250
<b>Shape:</b> Circular	<b>Width:</b>
<b>Material:</b> Polyvinyl chloride	<b>Total length:</b> 118.00
<b>Lining:</b>	<b>Pipe unit length:</b> 2.80
<b>Type:</b> Main	<b>Year laid:</b>
<b>Invert (upstream):</b>	<b>Invert (downstream):</b>
<b>Depth (upstream):</b>	<b>Depth (downstream):</b>
<b>Cover level (upstream):</b>	<b>Cover level (downstream):</b>

### Additional details

<b>Date:</b> 05/12/2018 11:44 AM	<b>Survey Abandoned:</b>
<b>Client project #:</b> Sanitary Sewer	<b>Inspected length:</b> 118.00
<b>Contractor project #:</b> HARD ROCK CASINO LP	<b>Pre-cleaning:</b> <input checked="" type="checkbox"/>
<b>Project type:</b> Video Inspection	<b>Blocked flow:</b> <input type="checkbox"/>
<b>Project supplier:</b>	<b>Regular CCTV:</b> <input type="checkbox"/>
<b>Client:</b> Hard Rock Ottawa L.P	<b>Reinspect with ZOOM:</b> <input type="checkbox"/>
<b>Purpose:</b> Assessment of complete remedial or renovation works	<b>Medium #:</b>
<b>Weather:</b> Light Snow	<b>Start position:</b>
<b>Operator:</b> RS	<b>End position:</b>
<b>Analyst:</b>	

### Internal Condition

<b>Grade:</b> 1	<b>Grade:</b> 3
<b>Total:</b> 0	<b>Total:</b> 4
<b>Peak:</b> 0	<b>Peak:</b> 2

### Operational Performance

### Comments

--

### Other information

<b>Other 1:</b> 45-5019	<b>Other 7:</b>
<b>Other 2:</b>	<b>Other 8:</b>
<b>Other 3:</b>	<b>Other 9:</b>
<b>Other 4:</b>	<b>Other 10:</b>
<b>Other 5:</b>	<b>PI5 (MAMR):</b>
<b>Other 6:</b>	<b>PI6 (MAMR):</b>

**#1 0.00**  
ST - Start of Survey

**#3 0.00**  
WL - Water level, 10%

**#2 0.00**  
MH - Manhole / node, MHS-44

**#4 2.30**  
(S1) DEG - Debris grease, from 7 o'clock to 5 o'clock, 5%



**#5 118.00**  
MH - Manhole / node, MHS-45



**#6 118.00**  
FH - Finish of Survey



**#7 120.60**  
DES - Debris silt, 5%



### Pipe identification

<b>Pipe:</b> MHSA-45... MHSA-44...	<b>Direction of inspection:</b> MHSA-44... --> MHSA-45...
<b>Direction of flow:</b> MHSA-44... --> MHSA-45...	<b>Direction:</b> Direction of flow

### Pipe location

<b>Road:</b> EARL ARMSTRONG	<b>City:</b> Template
<b>Crossroad:</b>	<b>Area:</b>
<b>Location:</b> Main road - Suburban/Rural	<b>Road segment:</b>

### Pipe characteristics

<b>Category:</b> Sanitary	<b>Size:</b> 250
<b>Shape:</b> Circular	<b>Width:</b>
<b>Material:</b> Polyvinyl chloride	<b>Total length:</b> 118.50
<b>Lining:</b>	<b>Pipe unit length:</b> 2.80
<b>Type:</b> Main	<b>Year laid:</b>
<b>Invert (upstream):</b>	<b>Invert (downstream):</b>
<b>Depth (upstream):</b>	<b>Depth (downstream):</b>
<b>Cover level (upstream):</b>	<b>Cover level (downstream):</b>

### Additional details

<b>Date:</b> 31/01/2019 1:54 PM	<b>Survey Abandoned:</b>
<b>Client project #:</b> Sanitary Sewer	<b>Inspected length:</b> 118.50
<b>Contractor project #:</b> HARD ROCK CASINO LP	<b>Pre-cleaning:</b> <input checked="" type="checkbox"/>
<b>Project type:</b> Video Inspection	<b>Blocked flow:</b> <input type="checkbox"/>
<b>Project supplier:</b>	<b>Regular CCTV:</b> <input type="checkbox"/>
<b>Client:</b> Hard Rock Ottawa L.P	<b>Reinspect with ZOOM:</b> <input type="checkbox"/>
<b>Purpose:</b> Assessment of complete remedial or renovation works	<b>Medium #:</b>
<b>Weather:</b> Dry	<b>Start position:</b>
<b>Operator:</b> RS	<b>End position:</b>
<b>Analyst:</b>	

### Internal Condition

<b>Grade:</b> 1	<b>Grade:</b> 3
<b>Total:</b> 0	<b>Total:</b> 8
<b>Peak:</b> 0	<b>Peak:</b> 2

### Operational Performance

### Comments

--

### Other information

<b>Other 1:</b> 455019	<b>Other 7:</b>
<b>Other 2:</b>	<b>Other 8:</b>
<b>Other 3:</b>	<b>Other 9:</b>
<b>Other 4:</b>	<b>Other 10:</b>
<b>Other 5:</b>	<b>PI5 (MAMR):</b>
<b>Other 6:</b>	<b>PI6 (MAMR):</b>

**#1 0.00**  
ST - Start of Survey

**#3 0.00**  
WL - Water level, 5%

**#2 0.00**  
MH - Manhole / node, MHSA-44...

**#4 0.00**  
(S1) DEG - Debris grease, from 4 o'clock to 8 o'clock, 5%



**#5 0.00**  
GO - General observation at this point, manhole cover no access



**#6 0.00**  
WL - Water level, 10%



**#7 62.00**  
(S2) DEG - Debris grease, at 12 o'clock, 5%



**#8 63.20**  
(F2) DEG - Debris grease, at 12 o'clock, 5%





### Pipe identification

<b>Pipe:</b> MHSA-46. MHSA-45.	<b>Direction of inspection:</b> MHSA-46. --> MHSA-45.
<b>Direction of flow:</b> MHSA-46. --> MHSA-45.	<b>Direction:</b> Direction of flow

### Pipe location

<b>Road:</b> EARL ARMSTRONG	<b>City:</b> Template
<b>Crossroad:</b>	<b>Area:</b>
<b>Location:</b> Main road - Suburban/Rural	<b>Road segment:</b>

### Pipe characteristics

<b>Category:</b> Sanitary	<b>Size:</b> 250
<b>Shape:</b> Circular	<b>Width:</b>
<b>Material:</b> Polyvinyl chloride	<b>Total length:</b> 77.50
<b>Lining:</b>	<b>Pipe unit length:</b> NA
<b>Type:</b> Main	<b>Year laid:</b>
<b>Invert (upstream):</b>	<b>Invert (downstream):</b>
<b>Depth (upstream):</b>	<b>Depth (downstream):</b>
<b>Cover level (upstream):</b>	<b>Cover level (downstream):</b>

### Additional details

<b>Date:</b> 05/12/2018 2:56 PM	<b>Survey Abandoned:</b>
<b>Client project #:</b> Sanitary Sewer	<b>Inspected length:</b> 77.50
<b>Contractor:</b> OTTAWA	<b>Pre-cleaning:</b> <input checked="" type="checkbox"/>
<b>project #:</b>	<b>Blocked flow:</b> <input type="checkbox"/>
<b>Project type:</b> Video Inspection	<b>Regular CCTV:</b> <input type="checkbox"/>
<b>Project supplier:</b>	<b>Reinspect with ZOOM:</b> <input type="checkbox"/>
<b>Client:</b> Hard Rock Ottawa L.P	<b>Medium #:</b>
<b>Purpose:</b> Assessment of complete remedial or renovation works	<b>Start position:</b>
<b>Weather:</b> Snow	<b>End position:</b>
<b>Operator:</b> RS	
<b>Analyst:</b>	

### Internal Condition

<b>Grade:</b> 1	<b>Grade:</b> 3
<b>Total:</b> 0	<b>Total:</b> 2
<b>Peak:</b> 0	<b>Peak:</b> 2

### Operational Performance

### Comments

--

### Other information

<b>Other 1:</b> 45-5019	<b>Other 7:</b>
<b>Other 2:</b>	<b>Other 8:</b>
<b>Other 3:</b>	<b>Other 9:</b>
<b>Other 4:</b>	<b>Other 10:</b>
<b>Other 5:</b>	<b>PI5 (MAMR):</b>
<b>Other 6:</b>	<b>PI6 (MAMR):</b>

**#1 0.00**  
ST - Start of Survey

**#3 0.00**  
WL - Water level, 5%

**#2 0.00**  
MH - Manhole / node, MHSA-46.

**#4 13.20**  
DES - Debris silt, 5%, ROCK



**#5 77.50**  
MH - Manhole / node, MHSA-45.



**#6 77.50**  
FH - Finish of Survey





### Pipe identification

<b>Pipe:</b> MHSA-47... MHSA-46...	<b>Direction of inspection:</b> MHSA-47... --> MHSA-46...
<b>Direction of flow:</b> MHSA-47... --> MHSA-46...	<b>Direction:</b> Direction of flow

### Pipe location

<b>Road:</b> EARL ARMSTRONG	<b>City:</b> Template
<b>Crossroad:</b>	<b>Area:</b>
<b>Location:</b> Main road - Suburban/Rural	<b>Road segment:</b>

### Pipe characteristics

<b>Category:</b> Sanitary	<b>Size:</b> 250
<b>Shape:</b> Circular	<b>Width:</b>
<b>Material:</b> Polyvinyl chloride	<b>Total length:</b> 109.50
<b>Lining:</b>	<b>Pipe unit length:</b> 2.80
<b>Type:</b> Main	<b>Year laid:</b>
<b>Invert (upstream):</b>	<b>Invert (downstream):</b>
<b>Depth (upstream):</b>	<b>Depth (downstream):</b>
<b>Cover level (upstream):</b>	<b>Cover level (downstream):</b>

### Additional details

<b>Date:</b> 31/01/2019 12:41 PM	<b>Survey Abandoned:</b>
<b>Client project #:</b> Sanitary Sewer	<b>Inspected length:</b> 109.50
<b>Contractor project #:</b> HARD ROCK CASINO LP	<b>Pre-cleaning:</b> <input checked="" type="checkbox"/>
<b>Project type:</b> Video Inspection	<b>Blocked flow:</b> <input type="checkbox"/>
<b>Project supplier:</b>	<b>Regular CCTV:</b> <input type="checkbox"/>
<b>Client:</b> Hard Rock Ottawa L.P	<b>Reinspect with ZOOM:</b> <input type="checkbox"/>
<b>Purpose:</b> Assessment of complete remedial or renovation works	<b>Medium #:</b>
<b>Weather:</b> Dry	<b>Start position:</b>
<b>Operator:</b> RS	<b>End position:</b>
<b>Analyst:</b>	

### Internal Condition

<b>Grade:</b> 1	<b>Grade:</b> 3
<b>Total:</b> 0	<b>Total:</b> 4
<b>Peak:</b> 0	<b>Peak:</b> 2

### Operational Performance

### Comments

--

### Other information

<b>Other 1:</b> 455019	<b>Other 7:</b>
<b>Other 2:</b>	<b>Other 8:</b>
<b>Other 3:</b>	<b>Other 9:</b>
<b>Other 4:</b>	<b>Other 10:</b>
<b>Other 5:</b>	<b>PI5 (MAMR):</b>
<b>Other 6:</b>	<b>PI6 (MAMR):</b>

**#1 0.00**  
ST - Start of Survey

**#3 0.00**  
WL - Water level, 5%

**#2 0.00**  
MH - Manhole / node, MHSA-47...

**#4 1.50**  
(S1) DEG - Debris grease, from 4 o'clock to 8 o'clock, 5%



**#5 68.00**  
WL - Water level, 10%



**#6 109.50**  
(F1) DEG - Debris grease, from 4 o'clock to 8 o'clock, 5%



**#7 109.50**  
MH - Manhole / node, MHSA-46...



**#8 109.50**  
FH - Finish of Survey



### Pipe identification

<b>Pipe:</b> MHSA-48 MHSA-47	<b>Direction of inspection:</b> MHSA-48 --> MHSA-47
<b>Direction of flow:</b> MHSA-48 --> MHSA-47	<b>Direction:</b> Direction of flow

### Pipe location

<b>Road:</b> HIGH RD	<b>City:</b> Template
<b>Crossroad:</b>	<b>Area:</b>
<b>Location:</b> Main road - Suburban/Rural	<b>Road segment:</b>

### Pipe characteristics

<b>Category:</b> Sanitary	<b>Size:</b> 250
<b>Shape:</b> Circular	<b>Width:</b>
<b>Material:</b> Polyvinyl chloride	<b>Total length:</b> 118.00
<b>Lining:</b>	<b>Pipe unit length:</b> 2.80
<b>Type:</b> Main	<b>Year laid:</b>
<b>Invert (upstream):</b>	<b>Invert (downstream):</b>
<b>Depth (upstream):</b>	<b>Depth (downstream):</b>
<b>Cover level (upstream):</b>	<b>Cover level (downstream):</b>

### Additional details

<b>Date:</b> 30/11/2018 12:03 PM	<b>Survey Abandoned:</b>
<b>Client project #:</b> Sanitary Sewer	<b>Inspected length:</b> 118.00
<b>Contractor project #:</b> HARD ROCK CASINO LP	<b>Pre-cleaning:</b> <input checked="" type="checkbox"/>
<b>Project type:</b> Video Inspection	<b>Blocked flow:</b> <input type="checkbox"/>
<b>Project supplier:</b>	<b>Regular CCTV:</b> <input type="checkbox"/>
<b>Client:</b> Hard Rock Ottawa L.P	<b>Reinspect with ZOOM:</b> <input type="checkbox"/>
<b>Purpose:</b> Assessment of complete remedial or renovation works	<b>Medium #:</b>
<b>Weather:</b> Dry	<b>Start position:</b>
<b>Operator:</b> RS	<b>End position:</b>
<b>Analyst:</b>	

### Internal Condition

<b>Grade:</b> 1	<b>Grade:</b> 3
<b>Total:</b> 0	<b>Total:</b> 4
<b>Peak:</b> 0	<b>Peak:</b> 2

### Operational Performance

### Comments

--

### Other information

<b>Other 1:</b> 45-5019	<b>Other 7:</b>
<b>Other 2:</b>	<b>Other 8:</b>
<b>Other 3:</b>	<b>Other 9:</b>
<b>Other 4:</b>	<b>Other 10:</b>
<b>Other 5:</b>	<b>PI5 (MAMR):</b>
<b>Other 6:</b>	<b>PI6 (MAMR):</b>

#1 0.00  
ST - Start of Survey

#3 0.00  
WL - Water level, 5%

#2 0.00  
MH - Manhole / node, MHSA-48

#4 2.90  
(S1) DEG - Debris grease, from 7 o'clock to 5 o'clock, 5%



#5 118.00  
MH - Manhole / node, MHSA-47



#6 118.00  
FH - Finish of Survey



#7 118.30  
(F1) DEG - Debris grease, from 7 o'clock to 5 o'clock, 5%



### Pipe identification

<b>Pipe:</b> MHSA-49 MHSA-48	<b>Direction of inspection:</b> MHSA-49 --> MHSA-48
<b>Direction of flow:</b> MHSA-49 --> MHSA-48	<b>Direction:</b> Direction of flow

### Pipe location

<b>Road:</b> HIGH RD	<b>City:</b> Template
<b>Crossroad:</b>	<b>Area:</b>
<b>Location:</b> Main road - Suburban/Rural	<b>Road segment:</b>

### Pipe characteristics

<b>Category:</b> Sanitary	<b>Size:</b> 250
<b>Shape:</b> Circular	<b>Width:</b>
<b>Material:</b> Polyvinyl chloride	<b>Total length:</b> 118.00
<b>Lining:</b>	<b>Pipe unit length:</b> 2.80
<b>Type:</b> Main	<b>Year laid:</b>
<b>Invert (upstream):</b>	<b>Invert (downstream):</b>
<b>Depth (upstream):</b>	<b>Depth (downstream):</b>
<b>Cover level (upstream):</b>	<b>Cover level (downstream):</b>

### Additional details

<b>Date:</b> 30/11/2018 11:47 AM	<b>Survey Abandoned:</b>
<b>Client project #:</b> Sanitary Sewer	<b>Inspected length:</b> 118.00
<b>Contractor project #:</b> HARD ROCK CASINO LP	<b>Pre-cleaning:</b> <input checked="" type="checkbox"/>
<b>Project type:</b> Video Inspection	<b>Blocked flow:</b> <input type="checkbox"/>
<b>Project supplier:</b>	<b>Regular CCTV:</b> <input type="checkbox"/>
<b>Client:</b> Hard Rock Ottawa L.P	<b>Reinspect with ZOOM:</b> <input type="checkbox"/>
<b>Purpose:</b> Assessment of complete remedial or renovation works	<b>Medium #:</b>
<b>Weather:</b> Dry	<b>Start position:</b>
<b>Operator:</b> RS	<b>End position:</b>
<b>Analyst:</b>	

### Internal Condition

<b>Grade:</b> 1	<b>Grade:</b> 3
<b>Total:</b> 0	<b>Total:</b> 4
<b>Peak:</b> 0	<b>Peak:</b> 2

### Operational Performance

### Comments

--

### Other information

<b>Other 1:</b> 45-5019	<b>Other 7:</b>
<b>Other 2:</b>	<b>Other 8:</b>
<b>Other 3:</b>	<b>Other 9:</b>
<b>Other 4:</b>	<b>Other 10:</b>
<b>Other 5:</b>	<b>PI5 (MAMR):</b>
<b>Other 6:</b>	<b>PI6 (MAMR):</b>

#1 0.00  
ST - Start of Survey

#3 0.00  
WL - Water level, 5%

#2 0.00  
MH - Manhole / node, MHSA-49

#4 5.50  
WL - Water level, 15%



#5 10.00  
WL - Water level, 10%



#6 74.10  
(S1) DEG - Debris grease, from 7 o'clock to 5 o'clock, 5%



#7 118.00  
(F1) DEG - Debris grease, from 7 o'clock to 5 o'clock, 5%



#8 118.00  
MH - Manhole / node, MHSA-48





### Pipe identification

<b>Pipe:</b> MHSA-50 MHSA-49	<b>Direction of inspection:</b> MHSA-50 --> MHSA-49
<b>Direction of flow:</b> MHSA-50 --> MHSA-49	<b>Direction:</b> Direction of flow

### Pipe location

<b>Road:</b> HIGH RD	<b>City:</b> Template
<b>Crossroad:</b>	<b>Area:</b>
<b>Location:</b> Main road - Suburban/Rural	<b>Road segment:</b>

### Pipe characteristics

<b>Category:</b> Sanitary	<b>Size:</b> 250
<b>Shape:</b> Circular	<b>Width:</b>
<b>Material:</b> Polyvinyl chloride	<b>Total length:</b> 119.00
<b>Lining:</b>	<b>Pipe unit length:</b> 2.80
<b>Type:</b> Main	<b>Year laid:</b>
<b>Invert (upstream):</b>	<b>Invert (downstream):</b>
<b>Depth (upstream):</b>	<b>Depth (downstream):</b>
<b>Cover level (upstream):</b>	<b>Cover level (downstream):</b>

### Additional details

<b>Date:</b> 30/11/2018 11:22 AM	<b>Survey Abandoned:</b>
<b>Client project #:</b> Sanitary Sewer	<b>Inspected length:</b> 119.00
<b>Contractor project #:</b> HARD ROCK CASINO LP	<b>Pre-cleaning:</b> <input checked="" type="checkbox"/>
<b>Project type:</b> Video Inspection	<b>Blocked flow:</b> <input type="checkbox"/>
<b>Project supplier:</b>	<b>Regular CCTV:</b> <input type="checkbox"/>
<b>Client:</b> Hard Rock Ottawa L.P	<b>Reinspect with ZOOM:</b> <input type="checkbox"/>
<b>Purpose:</b> Assessment of complete remedial or renovation works	<b>Medium #:</b>
<b>Weather:</b> Dry	<b>Start position:</b>
<b>Operator:</b> RS	<b>End position:</b>
<b>Analyst:</b>	

### Internal Condition

<b>Grade:</b> 1	<b>Grade:</b> 1
<b>Total:</b> 0	<b>Total:</b> 0
<b>Peak:</b> 0	<b>Peak:</b> 0

### Operational Performance

### Comments

--

### Other information

<b>Other 1:</b> 45-5019	<b>Other 7:</b>
<b>Other 2:</b>	<b>Other 8:</b>
<b>Other 3:</b>	<b>Other 9:</b>
<b>Other 4:</b>	<b>Other 10:</b>
<b>Other 5:</b>	<b>PI5 (MAMR):</b>
<b>Other 6:</b>	<b>PI6 (MAMR):</b>



**#1 0.00**  
ST - Start of Survey

**#3 0.00**  
WL - Water level, 5%

**#2 0.00**  
MH - Manhole / node, MHSA-50

**#4 119.00**  
MH - Manhole / node, MHSA-49



**#5 119.00**  
FH - Finish of Survey



### Pipe identification

<b>Pipe:</b> MHSA-51... MHSA-50...	<b>Direction of inspection:</b> MHSA-51... --> MHSA-50...
<b>Direction of flow:</b> MHSA-51... --> MHSA-50...	<b>Direction:</b> Direction of flow

### Pipe location

<b>Road:</b> HIGH RD	<b>City:</b> Template
<b>Crossroad:</b> HIGH RD	<b>Area:</b>
<b>Location:</b> Main road - Suburban/Rural	<b>Road segment:</b>

### Pipe characteristics

<b>Category:</b> Sanitary	<b>Size:</b> 250
<b>Shape:</b> Circular	<b>Width:</b>
<b>Material:</b> Polyvinyl chloride	<b>Total length:</b> 119.00
<b>Lining:</b>	<b>Pipe unit length:</b> 4.00
<b>Type:</b> Main	<b>Year laid:</b>
<b>Invert (upstream):</b>	<b>Invert (downstream):</b>
<b>Depth (upstream):</b>	<b>Depth (downstream):</b>
<b>Cover level (upstream):</b>	<b>Cover level (downstream):</b>

### Additional details

<b>Date:</b> 10/01/2019 2:33 PM	<b>Survey Abandoned:</b>
<b>Client project #:</b> Sanitary Sewer	<b>Inspected length:</b> 119.00
<b>Contractor project #:</b> HARD ROCK CASINO LP	<b>Pre-cleaning:</b> <input checked="" type="checkbox"/>
<b>Project type:</b> Video Inspection	<b>Blocked flow:</b> <input type="checkbox"/>
<b>Project supplier:</b>	<b>Regular CCTV:</b> <input type="checkbox"/>
<b>Client:</b> Hard Rock Ottawa L.P	<b>Reinspect with ZOOM:</b> <input type="checkbox"/>
<b>Purpose:</b> Assessment of complete remedial or renovation works	<b>Medium #:</b>
<b>Weather:</b> Dry	<b>Start position:</b>
<b>Operator:</b> DT	<b>End position:</b>
<b>Analyst:</b>	

### Internal Condition

<b>Grade:</b> 1	<b>Grade:</b> 1
<b>Total:</b> 0	<b>Total:</b> 0
<b>Peak:</b> 0	<b>Peak:</b> 0

### Operational Performance

### Comments

--

### Other information

<b>Other 1:</b> 455019	<b>Other 7:</b>
<b>Other 2:</b>	<b>Other 8:</b>
<b>Other 3:</b>	<b>Other 9:</b>
<b>Other 4:</b>	<b>Other 10:</b>
<b>Other 5:</b>	<b>PI5 (MAMR):</b>
<b>Other 6:</b>	<b>PI6 (MAMR):</b>

**#1 0.00**  
ST - Start of Survey

**#3 0.00**  
WL - Water level, 5%

**#2 0.00**  
MH - Manhole / node, MHSA-51...

**#4 119.00**  
MH - Manhole / node, MHSA-50...



**#5 119.00**  
FH - Finish of Survey



### Pipe identification

<b>Pipe:</b> MHSA-52.. MHSA-51..	<b>Direction of inspection:</b> MHSA-52.. --> MHSA-51..
<b>Direction of flow:</b> MHSA-52.. --> MHSA-51..	<b>Direction:</b> Direction of flow

### Pipe location

<b>Road:</b> HIGH RD	<b>City:</b> Template
<b>Crossroad:</b> HIGH RD	<b>Area:</b>
<b>Location:</b> Main road - Suburban/Rural	<b>Road segment:</b>

### Pipe characteristics

<b>Category:</b> Sanitary	<b>Size:</b> 250
<b>Shape:</b> Circular	<b>Width:</b>
<b>Material:</b> Polyvinyl chloride	<b>Total length:</b> 118.10
<b>Lining:</b>	<b>Pipe unit length:</b> 4.00
<b>Type:</b> Main	<b>Year laid:</b>
<b>Invert (upstream):</b>	<b>Invert (downstream):</b>
<b>Depth (upstream):</b>	<b>Depth (downstream):</b>
<b>Cover level (upstream):</b>	<b>Cover level (downstream):</b>

### Additional details

<b>Date:</b> 10/01/2019 2:07 PM	<b>Survey Abandoned:</b>
<b>Client project #:</b> Sanitary Sewer	<b>Inspected length:</b> 118.10
<b>Contractor project #:</b> HARD ROCK CASINO LP	<b>Pre-cleaning:</b> <input checked="" type="checkbox"/>
<b>Project type:</b> Video Inspection	<b>Blocked flow:</b> <input type="checkbox"/>
<b>Project supplier:</b>	<b>Regular CCTV:</b> <input type="checkbox"/>
<b>Client:</b> Hard Rock Ottawa L.P	<b>Reinspect with ZOOM:</b> <input type="checkbox"/>
<b>Purpose:</b> Assessment of complete remedial or renovation works	<b>Medium #:</b>
<b>Weather:</b> Dry	<b>Start position:</b>
<b>Operator:</b> DT	<b>End position:</b>
<b>Analyst:</b>	

### Internal Condition

<b>Grade:</b> 1	<b>Grade:</b> 1
<b>Total:</b> 0	<b>Total:</b> 0
<b>Peak:</b> 0	<b>Peak:</b> 0

### Operational Performance

### Comments

--

### Other information

<b>Other 1:</b> 455019	<b>Other 7:</b>
<b>Other 2:</b>	<b>Other 8:</b>
<b>Other 3:</b>	<b>Other 9:</b>
<b>Other 4:</b>	<b>Other 10:</b>
<b>Other 5:</b>	<b>PI5 (MAMR):</b>
<b>Other 6:</b>	<b>PI6 (MAMR):</b>

**#1 0.00**  
ST - Start of Survey

**#3 0.00**  
WL - Water level, 5%

**#2 0.00**  
MH - Manhole / node, MHSA-52..

**#4 118.10**  
MH - Manhole / node, MHSA-51..



**#5 118.10**  
FH - Finish of Survey



### Pipe identification

<b>Pipe:</b> MHSA-53 MHSA-52	<b>Direction of inspection:</b> MHSA-53 --> MHSA-52
<b>Direction of flow:</b> MHSA-53 --> MHSA-52	<b>Direction:</b> Direction of flow

### Pipe location

<b>Road:</b> HIGH RD	<b>City:</b> Template
<b>Crossroad:</b> EARL ARMSTRONG	<b>Area:</b>
<b>Location:</b> Main road - Suburban/Rural	<b>Road segment:</b>

### Pipe characteristics

<b>Category:</b> Sanitary	<b>Size:</b> 250
<b>Shape:</b> Circular	<b>Width:</b>
<b>Material:</b> Polyvinyl chloride	<b>Total length:</b> 118.00
<b>Lining:</b>	<b>Pipe unit length:</b> 2.80
<b>Type:</b> Main	<b>Year laid:</b>
<b>Invert (upstream):</b>	<b>Invert (downstream):</b>
<b>Depth (upstream):</b>	<b>Depth (downstream):</b>
<b>Cover level (upstream):</b>	<b>Cover level (downstream):</b>

### Additional details

<b>Date:</b> 26/11/2018 2:41 PM	<b>Survey Abandoned:</b>
<b>Client project #:</b> Sanitary Sewer	<b>Inspected length:</b> 118.00
<b>Contractor project #:</b> HARD ROCK CASINO LP	<b>Pre-cleaning:</b> <input checked="" type="checkbox"/>
<b>Project type:</b> Video Inspection	<b>Blocked flow:</b> <input type="checkbox"/>
<b>Project supplier:</b>	<b>Regular CCTV:</b> <input type="checkbox"/>
<b>Client:</b> Hard Rock Ottawa L.P	<b>Reinspect with ZOOM:</b> <input type="checkbox"/>
<b>Purpose:</b> Assessment of complete remedial or renovation works	<b>Medium #:</b>
<b>Weather:</b> Light Rain	<b>Start position:</b>
<b>Operator:</b> RS	<b>End position:</b>
<b>Analyst:</b>	

### Internal Condition

<b>Grade:</b> 1	<b>Grade:</b> 3
<b>Total:</b> 0	<b>Total:</b> 4
<b>Peak:</b> 0	<b>Peak:</b> 2

### Operational Performance

### Comments

--

### Other information

<b>Other 1:</b> 45-5019	<b>Other 7:</b>
<b>Other 2:</b>	<b>Other 8:</b>
<b>Other 3:</b>	<b>Other 9:</b>
<b>Other 4:</b>	<b>Other 10:</b>
<b>Other 5:</b>	<b>PI5 (MAMR):</b>
<b>Other 6:</b>	<b>PI6 (MAMR):</b>

#1 0.00  
ST - Start of Survey

#3 0.00  
WL - Water level, 5%

#2 0.00  
MH - Manhole / node, MHSA-53

#4 107.70  
(S1) DEG - Debris grease, from 4 o'clock to 8 o'clock, 5%



#5 118.00  
MH - Manhole / node, MHSA-52



#6 118.00  
FH - Finish of Survey



#7 118.80  
(F1) DEG - Debris grease, from 4 o'clock to 8 o'clock, 5%



### Pipe identification

<b>Pipe:</b> MHSA-54 MHSA-53	<b>Direction of inspection:</b> MHSA-54 --> MHSA-53
<b>Direction of flow:</b> MHSA-54 --> MHSA-53	<b>Direction:</b> Direction of flow

### Pipe location

<b>Road:</b> HIGH RD	<b>City:</b> Template
<b>Crossroad:</b> EARL ARMSTRONG	<b>Area:</b>
<b>Location:</b> Main road - Suburban/Rural	<b>Road segment:</b>

### Pipe characteristics

<b>Category:</b> Sanitary	<b>Size:</b> 250
<b>Shape:</b> Circular	<b>Width:</b>
<b>Material:</b> Polyvinyl chloride	<b>Total length:</b> 95.00
<b>Lining:</b>	<b>Pipe unit length:</b> 2.80
<b>Type:</b> Main	<b>Year laid:</b>
<b>Invert (upstream):</b>	<b>Invert (downstream):</b>
<b>Depth (upstream):</b>	<b>Depth (downstream):</b>
<b>Cover level (upstream):</b>	<b>Cover level (downstream):</b>

### Additional details

<b>Date:</b> 26/11/2018 2:06 PM	<b>Survey Abandoned:</b>
<b>Client project #:</b> Sanitary Sewer	<b>Inspected length:</b> 95.00
<b>Contractor project #:</b> HARD ROCK CASINO LP	<b>Pre-cleaning:</b> <input checked="" type="checkbox"/>
<b>Project type:</b> Video Inspection	<b>Blocked flow:</b> <input type="checkbox"/>
<b>Project supplier:</b>	<b>Regular CCTV:</b> <input type="checkbox"/>
<b>Client:</b> Hard Rock Ottawa L.P	<b>Reinspect with ZOOM:</b> <input type="checkbox"/>
<b>Purpose:</b> Assessment of complete remedial or renovation works	<b>Medium #:</b>
<b>Weather:</b> Light Rain	<b>Start position:</b>
<b>Operator:</b> RS	<b>End position:</b>
<b>Analyst:</b>	

### Internal Condition

<b>Grade:</b> 1	<b>Grade:</b> 3
<b>Total:</b> 0	<b>Total:</b> 2
<b>Peak:</b> 0	<b>Peak:</b> 2

### Operational Performance

### Comments

--

### Other information

<b>Other 1:</b> 45-5019	<b>Other 7:</b>
<b>Other 2:</b>	<b>Other 8:</b>
<b>Other 3:</b>	<b>Other 9:</b>
<b>Other 4:</b>	<b>Other 10:</b>
<b>Other 5:</b>	<b>PI5 (MAMR):</b>
<b>Other 6:</b>	<b>PI6 (MAMR):</b>



**#1 0.00**  
ST - Start of Survey

**#3 0.00**  
WL - Water level, 5%

**#2 0.00**  
MH - Manhole / node, MHS-54

**#4 6.40**  
(S1) DEG - Debris grease, from 4 o'clock to 8 o'clock, 5%



**#5 95.00**  
MH - Manhole / node, MHS-53



**#6 95.00**  
FH - Finish of Survey



### Pipe identification

<b>Pipe:</b> MHSA-55.. MHSA-54..	<b>Direction of inspection:</b> MHSA-55.. --> MHSA-54..
<b>Direction of flow:</b> MHSA-55.. --> MHSA-54..	<b>Direction:</b> Direction of flow

### Pipe location

<b>Road:</b> HIGH RD	<b>City:</b> Template
<b>Crossroad:</b> ALBION RD	<b>Area:</b>
<b>Location:</b> Main road - Suburban/Rural	<b>Road segment:</b>

### Pipe characteristics

<b>Category:</b> Sanitary	<b>Size:</b> 250
<b>Shape:</b> Circular	<b>Width:</b>
<b>Material:</b> Polyvinyl chloride	<b>Total length:</b> 118.00
<b>Lining:</b>	<b>Pipe unit length:</b> 4.00
<b>Type:</b> Main	<b>Year laid:</b>
<b>Invert (upstream):</b>	<b>Invert (downstream):</b>
<b>Depth (upstream):</b>	<b>Depth (downstream):</b>
<b>Cover level (upstream):</b>	<b>Cover level (downstream):</b>

### Additional details

<b>Date:</b> 10/01/2019 12:21 PM	<b>Survey Abandoned:</b>
<b>Client project #:</b> Sanitary Sewer	<b>Inspected length:</b> 118.00
<b>Contractor project #:</b> HARD ROCK CASINO LP	<b>Pre-cleaning:</b> <input checked="" type="checkbox"/>
<b>Project type:</b> Video Inspection	<b>Blocked flow:</b> <input type="checkbox"/>
<b>Project supplier:</b>	<b>Regular CCTV:</b> <input type="checkbox"/>
<b>Client:</b> Hard Rock Ottawa L.P	<b>Reinspect with ZOOM:</b> <input type="checkbox"/>
<b>Purpose:</b> Assessment of complete remedial or renovation works	<b>Medium #:</b>
<b>Weather:</b> Dry	<b>Start position:</b>
<b>Operator:</b> DT	<b>End position:</b>
<b>Analyst:</b>	

### Internal Condition

<b>Grade:</b> 1	<b>Grade:</b> 1
<b>Total:</b> 0	<b>Total:</b> 0
<b>Peak:</b> 0	<b>Peak:</b> 0

### Operational Performance

### Comments

--

### Other information

<b>Other 1:</b> 455019	<b>Other 7:</b>
<b>Other 2:</b>	<b>Other 8:</b>
<b>Other 3:</b>	<b>Other 9:</b>
<b>Other 4:</b>	<b>Other 10:</b>
<b>Other 5:</b>	<b>PI5 (MAMR):</b>
<b>Other 6:</b>	<b>PI6 (MAMR):</b>

**#1 0.00**  
ST - Start of Survey

**#3 0.00**  
WL - Water level, 5%

**#2 0.00**  
MH - Manhole / node, MHSA-55..

**#4 118.00**  
MH - Manhole / node, MHSA-54..



**#5 118.00**  
FH - Finish of Survey



**Appendix C**  
Storm Servicing Information

---

**RIDEAU CARLETON RACEWAY  
STORMWATER DESIGN**

Prepared for:  
PBK Architects Inc.  
6188-555 Richmond Street West  
Toronto, ON M5V 3B1

**Oliver, Mangione, McCalla & Associates**  
a division of Trow Consulting Engineers Ltd.

154 Colonnade Road South  
Nepean, Ontario K2E 7J5  
Telephone: (613) 225-9940  
Facsimile: (613) 225-7337

Project No. MP13140A  
Date: September 3, 1999

---

# Table of Contents

<b>1.0 Introduction</b>	<b>1</b>
1.1 Background .....	1
1.2 Terms of Reference .....	1
1.3 Background Information .....	1
<b>2.0 Site Description</b>	<b>2</b>
2.1 Site Location and Description .....	2
2.2 Topography and Drainage .....	2
<b>3.0 Stormwater Management</b>	<b>3</b>
3.1 Stormwater Management Concerns .....	3
3.2 Source Controls .....	3
3.3 End-of -Pipe Facilities .....	5
<b>4.0 Summary</b>	<b>8</b>

## TABLES

Table 1. Available parking lot storage and sewer release rates .....	9
Table 2. Available storage volumes .....	9

## APPENDICES

“A” Storm Sewer Calculation Sheet

# 1.0 Introduction

## 1.1 Background

The Rideau Carleton Raceway is a harness racing facility located in a rural area within the municipal boundaries of the City of Gloucester, Ontario, about 15 kilometres south of downtown Ottawa. The facility, which was built in 1962, consists of a grandstand, 5/8 mile racetrack, horse barns, offices and associated buildings.

The racetrack is currently undergoing expansion and renovation to accommodate a gaming facility. The following report will address the stormwater aspect of the site.

## 1.2 Terms of Reference

This report was prepared to investigate current hydrological conditions and to make recommendations to improve conditions considering the proposed expansion. Particular concerns have been expressed regarding potential impacts to the Provincially Classified Class I Leirim Wetland, the southern boundary of which is located about 500 metres to the north of the facility.

## 1.3 Background Information

The Leirim Wetland was included in numerous detail reports prepared for the City of Gloucester by Cumming Cockburn Limited (CCL). Two CCL reports that we have referenced are, "*Planning for Leirim an Integrated Approach, Volume II Master Drainage Plan, August 1991*", and, "*Leirim Development Area, Stormwater Management Environmental Study Report and Pre-Design, October 1994*". As part of the report, Golder Associates Limited (GAL) prepared a report entitled, "*Hydrogeological and Geotechnical Considerations Pre-Design of Stormwater Management Works Leirim Development Area, August 1994*". The design procedure and parameters followed are those outlined in the Ministry of Environment (MOE) publication, "*Stormwater Management Practices Planning and Design Manual*", June 1994 (SWMP).

## 2.0 Site Description

### 2.1 Site Location and Description

The Rideau Carleton Raceway is located at 4837 Albion Road in the City of Gloucester, near the intersections of Albion Road with High and Rideau Roads. The site is approximately 4 kilometres southeast of the Macdonald-Cartier International Airport and about 15 kilometres southeast of downtown Ottawa.

The lands owned by the Raceway extend from Albion Road in the west to Bank Street (Hwy 31) in the east, and occupy an area of approximately 130 hectares.

This report will address only the lands which are being redeveloped. This will be approximately 11.83 hectares of land on the west and south side of the property. This land is presently used as a parking area and includes the existing and proposed building. There is an additional 1.91 hectares in the south west corner that may drain to the pond in the future. Therefore the calculations will be based on a total contributing area of 13.74 hectares.

### 2.2 Topography and Drainage

The Rideau Carleton Raceway site drains northwards into the Findlay Creek Drain and the Leitrim Wetlands. The Leitrim Wetlands have been classified as a Provincially Significant Wetland. This wetland and the implications of development within the watershed which contains this wetland have been studied in detail in connection with the City of Gloucester Official Plan Amendment No. 10 for the Leitrim Urban Community.

The western part of the raceway property, where the redevelopment will take place, is situated on a ridge of higher land which slopes downward towards the north and east. The higher land to the south and west is at an elevation of 113 to 116 metres above sea level, while the land to the north, which includes the Leitrim Wetlands, is at elevations of 95 to 98 m.a.s.l.

The parking area located to the west of the grandstand building is equipped with a private storm sewer system. Water from this system is conveyed to a large (100 m diameter) pond located in the north end of the infield. Currently, the pond water is used for dust control on the racetrack and as a storage reservoir for fire-fighting purposes.



The dominant surficial feature in the area is a deposit of stratified sand which forms a northwest/southeast trending ridge from Greely in the south to the Macdonald-Cartier Airport in the north. The western portion of the racetrack property is located on the stratified glacial deposit.

### **3.0 Stormwater Management**

#### **3.1 Stormwater Management Concerns**

The site has been previously developed without the incorporation of stormwater management practices, therefore, there is the opportunity to improve the quality of runoff from the site.

The studies mentioned earlier provide guidance in setting stormwater management objectives for the further development of the Rideau Carleton Raceway site. The following stormwater management objectives are proposed:

- restrict the rate of post-development runoff for events up to the 1:100 year storm to 1:5 year pre-development levels;
- maximize the infiltration of runoff so as to minimize groundwater impacts;
- apply all feasible source controls to maximize the quality of runoff and minimize the runoff volumes requiring treatment;
- treat all runoff from the site;
- augment low flows in downstream water courses;
- mitigate temperature increase arising at any of the stormwater treatment works; and
- integrate an ongoing operation and maintenance plan into the stormwater treatment works to assure continued performance;

The preceding objectives will require aggressive use of source controls, measures to maximize infiltration, and a treatment facility, which may take the form of a constructed wetland or a wet pond. Detention of runoff in the treatment facility will improve the quality of discharged flows, reduce flow rates and erosion downstream of the site, and augment flows after storm events.

#### **3.2 Source Controls**

Source controls recommended for this site include:



- erosion and sediment controls during construction, and
- catch basin restrictors in the storm sewers to detain stormwater on the parking lots.

Control of erosion on construction sites and the removal of sediments from construction site runoff is very important if downstream areas are to be protected. During all construction, erosion and sedimentation will be controlled by the following techniques:

- i) Limitation of the extent of exposed soils at any given time.
- ii) Revegetation of exposed areas as soon as possible.
- iii) Minimization of area to be cleared and grubbed.
- iv) Silt fences and check dams.

### 3.3 Conveyance Controls

Three categories of stormwater conveyance controls are:

-  pervious pipe systems,
-  pervious catch basins, and
-  grassed swales.

The existing site is suitable for all three options. Pervious catch-basins and pervious pipe systems will be used throughout the paved parking lots and road entrances. Grass ditches will be used to convey runoff from the gravel parking areas. The grass swales will eventually discharge to the proposed storm sewer network.

The native soil is very pervious and the water table is well below the ground surface in the area of the parking lots. This makes the parking lot site ideal for infiltration practices. The pervious pipe and catch-basin system will incorporate the following design details:

- pre-treatment using oversized sumps,
- filter fabric,
- clear stone, and
- anti-seepage cut walls.

The total area that drains to the catch basins is approximately 6.47 hectares with an runoff coefficient of approximately 0.70. The perforated catch basins will be designed to infiltrate 5 mm (minimum recommended by the MOE SWMP 1994 Manual) of runoff from the impervious area. The required storage volume for infiltration would be:

$$6.47 \text{ ha.} \times 5 \text{ mm} \times 0.70 = 226 \text{ cubic metres}$$

There are 34 catch basins that will be connected to a dry well. Therefore each dry well must be designed to contain 6.7 cubic metres. SK1 shows the proposed dry well design. Ten (10) infiltration chambers will be required at each catch basin. Runoff from the gravel parking area will sheet flow overland towards a grass swale. Pre-treatment of storm runoff will be provided by a grass side slopes, which will reduce the velocity, remove litter, promote infiltration and remove some of the suspended solids before entering the pond.







Appendix A contains the storm drainage calculation sheet. The pipes have been designed to convey the restricted flow rates. Flow from the building roof enters at manhole 108 located at the front entrance of the gaming facility. An allowance has been made for 20 L/s for the 1.97 hectares of land in the south west corner. This is comparable to the release rates for the proposed paved parking lots. Flow from the north west parking lot has been included as the future controlled rate of 60 L/s (3 restrictors).

The existing 200 mm pipe in front of the Grandstand will be used once it is cleaned and inspected. This sewer may become surcharged during a heavy rainstorm. Therefore it must be tv inspected. The video will show if there are any connections to the sewer. If there are any connections then it must be determined what these connections are and where do the lead. The decision will then be made if surcharging is suitable for this segment of pipe. Surcharging could cause water to exit the catch basin manholes located in front of the grandstand possibly causing some erosion at the base of the track. The storm sewer will be installed at the same time as the sanitary force main unless, as discussed above the sewer is not deemed suitable.





Source controls and conveyance controls in themselves will not provide the entire treatment, therefore, end-of-pipe treatment will be necessary.

### 3.3 End-Of-Pipe SWM Facility

The MOEE SWMP Planning and Design Manual categorises nine end-of-pipe SWM facilities as follows:

-  wet ponds,
-  wetlands,
-  dry ponds,
-  infiltration basins,
-  infiltration trenches,
-  filter strips,
-  buffer strips,
-  sand filters, and
-  oil/grit separators.

The facilities recommended for use at the Rideau Carleton Raceway are:

-  detention ponds or tanks,
-  infiltration trenches,
-  infiltration basins,
-  wetponds, and
-  wetland retention facilities.

The recommended end-of-pipe treatment is a combination wet pond and infiltration trench.

The existing pond will be used as the proposed wet pond. A two phase approach will be used

### **Phase I**

Phase I will use the existing outlet from the pond. The existing outlet must be located and cleaned. A new swale will be excavated in order to connect the outlet to the existing swale. The water level in the pond will be monitored in a stilling well with the information stored on a data logger. If there are more than four (4) pond overflows per year then phase II construction will begin. The criteria is based on the calculations that follow and the design criteria of four overflows allowed for a quality control pond tributary to the Rideau River. The calculations that will follow show that a pond overflow is unlikely.

### **Phase II**

#### **Quality Control**

Phase II will consist of a new outlet from the pond and a new grass-lined ditch. The capacity of the existing wet pond will be verified based on the development area being 85 percent impervious. The wet pond will consist of an extended detention portion and a permanent pool. The volume of the extended detention and permanent pool are taken from the Ministry of Environment Stormwater Management Practices, Planning and Design Manual, June 1994, which states 40 m<sup>3</sup>/ha for extended detention, and 210 m<sup>3</sup>/ha for the permanent pool for a development that is 85 percent impervious, and a receiving stream that requires Level 1 (Ministry of Natural Resources) protection. Examples of Level 1 habitat include spawning, rearing and highly protective feeding areas, and groundwater recharge areas in coldwater streams.

The quality portion of the pond is based upon 12.88 hectares. Runoff from the building roof area does not require treatment therefore is not included in the calculations. The required pond volumes are then:

Permanent Pool:

$$\begin{aligned} V &= 210 \text{ m}^3/\text{ha} \times 12.88 \text{ ha} \\ &= 2,705 \text{ m}^3 \end{aligned}$$

Extended Detention:

$$\begin{aligned} V &= 40 \text{ m}^3/\text{ha} \times 12.88 \text{ ha} \\ &= 515 \text{ m}^3 \end{aligned}$$

The existing pond bottom is at approximately 103.00 metres with a surface diameter of 71 metres. The water surface elevation is at 104.00 metres with a diameter of 91 metres. Available storage volume is calculated as follows:

$$\begin{aligned} V &= (1/3) \times A \times d \quad (A = \text{surface area, } d = \text{depth of water}) \\ &= (1/3) \times (3959 \text{ m}^2 + 6504 \text{ m}^2 + (3959 \text{ m}^2 \times 6504 \text{ m}^2)^{1/2} \text{ m}^2) \times 1.00 \text{ m} \\ &= 5179 \text{ m}^3 \end{aligned}$$

The permanent pool in the wet pond is approximately 5179 cubic metres which is more than 2 times the required volume. The extended detention will be designed for a maximum depth of 0.3 metres. This will provide approximately 2,350 cubic metres which is more than 5 times the required volume.

Drawing SWM3 shows the pond details. The pond bottom will be at 103.0 metres. The quality control outlet from the pond will be at 104.00 metres.

The quality control orifice diameter is based on the falling head orifice equation:

$$\begin{aligned} t &= \frac{2(A_p)(h_1^{.5} - h_2^{.5})}{[CA_0(2g)^{.5}]}(\text{sec}) \\ A_p &= 7850 \text{ m}^2 \\ h_1 &= .30 \text{ m} \\ h_2 &= 0 \text{ m} \\ C &= 0.60 \\ g &= 9.81 \text{ m/s}^2 \\ A_0 &= \frac{\pi d^2}{4} \\ d &= \text{m} \\ t &= \frac{2(7850 \text{ m}^2)(0.30 \text{ m})^{.5}}{[0.60 \times \frac{\pi d^2}{4} \times (2 \times 9.81 \text{ m/s}^2)^{.5}]} \\ &= 8599/2.087 d^2 (\text{sec}) \end{aligned}$$

A pipe diameter of 175 mm:

$$t = 37 \text{ hrs.}$$

To assist in the removal of debris and to prevent access to the sewers, gratings are proposed for the inlet and outlet control structures.

### Quantity Control

The allowable release rate from the 13.74 hectare redevelopment must be restricted to 1:5 year pre-development level. The report “*Planning for Leitrim an Integrated Approach, Volume II Master Drainage Plan, August 1991*”, gives the 5 year flow as 4515 L/s for an area of 293 hectares. Pro-rating this value our release rate would be 213 L/s. Quantity control from the pond will be provided by an orifice for all storms up to the 100 year event. For events greater, water will flow over a weir set at elevation 105.1 m. Flows through the orifice are based upon the maximum head that will occur. The head is measured to the centerline of the orifice. The orifice equation is as follows:

Where

$$Q = CA(2gh)^{\frac{1}{2}}$$

$$C = 0.60$$

$$A = \text{area of orifice (m}^2\text{)}$$

$$g = 9.81 \text{ m/s}$$

$$H = \text{head over centerline of orifice}$$

Example:

a) 175 mm orifice at elevation 104.0 metres

$$Q = .6x(.785x(.175\text{m})^2/4)(2x9.81x(105.1\text{m}-104.0\text{m}+.175\text{m}/2))^{\frac{1}{2}}$$

$$Q = 64 \text{ L/s}$$

b) 300 mm orifice at elevation 104.0 metres

$$Q = .6x(.785x(.300\text{m})^2/4)(2x9.81x(105.1\text{m}-104.3\text{m}+.300\text{m}/2))^{\frac{1}{2}}$$

$$Q = 151 \text{ L/s}$$

The head over the orifice would be 1.1 metres above the low flow orifice (175mm) and 0.65 metres above the high flow orifice (300mm). The total combined outflow would be 215 L/s. SK2 shows the proposed outlet control manhole if Phase II should be implemented.

Three (3) areas are available for storage of excess stormwater runoff. Table 1 lists the available storage volumes and release rates for the four (4) paved areas.

**Table 1. Available parking lot storage and sewer release rates.**

Parking Lot Number	Available Storage Volume (m <sup>3</sup> )	Release Rate (L/s)
P1	260	40

P2	1063	20
P3	239	40
P4	621	20
Total =	2183	120

Table 2 shows the available storage volumes at the three different areas.

**Table 2. Available storage volumes.**

Location	Available Storage Volume (m <sup>3</sup> )
Pond	7529
Dry wells	223
Parking lots	2183
Total =	9935

The total available storage volume is 9935 m<sup>3</sup>. Storage volume requirements can be calculated by various methods (Modified Rational Method, et.). To show that there is ample storage volume available a zero release rate was assumed as the worst case scenario. The total runoff volume is then equal to the total rainfall multiplied by the runoff coefficient by the area. The following calculations illustrate the total runoff from the 100 year storm is less than the available storage volume.

$$\text{Runoff volume} = \text{runoff coefficient} \times \text{rainfall} \times \text{area}$$

The 100 year rainfall for a 24 hour storm is 88.6 mm.

$$C = \frac{(0.2 \times 2.32) + (0.6 \times 4.09) + (0.7 \times 6.47) + (0.9 \times 0.86)}{13.74}$$

$$C = 0.60$$

$$\text{Runoff volume} = 0.60 \times .0886 \text{ m} \times 137400 \text{ m}^2$$

$$\text{Runoff volume} = 7304 \text{ m}^3$$

This calculation demonstrates that with a zero release rate from the site there is sufficient storage available for the 100 year storm. The assumptions are made for the current development conditions. If future parking areas are developed the storage volumes in Table 2 will then be amended to reflect the new conditions.

If Phase II work is required the receiving water coarse for the pond outlet will be the existing drain on the northern boundary of the property. A grass lined infiltration trench with approximately 100 m<sup>3</sup> storage will connect the pond with the receiving water coarse. Although the 100 m<sup>3</sup> of storage is not required for quality or quantity control it will permit additional infiltration.

#### 4.0 Summary

This report has outlined a stormwater plan that will treat runoff from the proposed 13.74 hectare redevelopment and expansion area of the Rideau Carleton Raceway.

Flow from this area will be controlled by inlet restrictors in the catch-basins which will minimize peak flows from the parking lot. Dry wells will be attached to each catch basin while final control is by utilizing the existing pond located inside of the race track. This system will treat all runoff from the site. To minimize groundwater impacts the infiltration of runoff has been maximized. This is accomplished by providing pervious catch-basins, pervious pipes, grass-lined swales, and infiltration trench downstream of the pond outlet. This type of design will augment low flows in downstream water courses by increasing the amount of water that is infiltrated into the ground and thereby decreasing the amount of water that enters the pond. Less water too the pond also means that storm water will not have time to heat up. To further avoid temperature increase the outlet from the pond will be from the bottom. Furthermore, it will minimize the runoff volumes requiring treatment in the existing pond

Phase I will consist of cleaning the outlet and connecting to the existing swale. The water levels will be monitored and measured constantly using a stilling well recording the information on a data logger. If there are more than 4 overflows per year phase II construction of the new pond outlet as shown on SWM3 will be implemented.



The system will have an ongoing Operation and Maintenance Plan to assure continued performance. Sumps will be cleaned yearly with copies sent to the City of Gloucester and the SNRCA.

**Oliver, Mangione, McCalla & Associates**  
a division of Trow Consulting Engineers Ltd.

Stephen J. Pichette, P.Eng.  
Manager  
Civil, Private Division

Charles B. Warnock, P.Eng.  
Senior Water Resources Engineer  
Civil, Private Division

cbw/cbw

# Appendix A: Storm Sewer Calculation Sheet

City of Gloucester  
**STORM SEWER COMPUTATION FORM**  
 Client: PBK  
 Project: Rideau Carleton Raceway Redevelopment  
 Date: September, 1999  
 Designed by: CBW  
 Checked by: Charles Warnock

Rational Method:  
 (IDF curve for Ottawa Airport  
 5 yr frequency)

Q = 2.78AIR  
 Tc = Time of Concentration = 15  
 n = 0.013  
 R = Runoff coefficient  
 I = Rainfall Intensity = 30.3 x t<sup>-0.7270</sup>

Area	From MH	To MH	Roof Flow (L/s)	Roof Area (ha)	AREA (ha)			Ind. 2.78AR	Accum. 2.78AR	Time of Conc. (min)	Rainfall Intensity (mm/hr) (I)	Flow Restriction (L/s)	Peak Flow Q(L/sec)	Flow in Sewer (L/s)	Type of Pipe	SEWER DATA			Capacity (L/sec)	Velocity (m/sec)	Time of Flow (min)	REMARKS		
					0.2	0.6	0.9									Diameter (mm) (nom.)	(act.)	Slope (%)					Length (m)	
								0.06																
	114	113						0.06	0.15	0.15	15.0	83.0	20.0	12.5	12.5	Conc.	250	254	0.43	64.5	40.7	0.80	1.34	
	113	109						2.63	6.58	6.73	16.3	78.0	100.0	525.0	112.5	Conc.	375	381	0.43	121.5	119.9	1.05	1.93	
	110	109						1.97	4.93	4.93	15.0	83.0	20.0	409.3	20.0	Conc.	300	305	2.46	28.5	158.2	2.17	0.20	
	108	109	178.6	0.86				0.00	0.00	0.00	15.0	83.0	0.0	178.6	178.6	Conc.	375	381	1.00	28.0	182.9	1.60	0.29	
	109	104						0.79	1.98	13.64	18.3	71.9	40.0	981.1	351.0	Conc.	600	610	0.32	22.0	362.4	1.24	0.30	
	105	104			0.41			1.29	3.48	3.48	15.0	83.0	20.0	287.2	20.0	Conc.	300	305	1.32	18.0	115.9	1.59	0.19	
	104	102						0.50	1.25	18.35	15.3	81.9	40.0	1502.2	238.6	Conc.	600	610	1.00	65.0	640.6	2.19	0.49	
	103	102						0.00	0.00	0.00	15.0	83.0	0.0	0.0	0.0	Conc.	300	305	1.87	81.0	138.0	1.89	0.71	
	102A	102						3.52	8.81	8.81	15.0	83.0	60.0	731.3	60.0	Conc.	300	305	1.00	59.0	100.9	1.38	0.71	
	102	101						0.00	27.18	15.8	15.8	80.0	2173.0	298.6	Conc.	750	762	1.94	92.0	1617.7	3.55	0.43		
	117	116			0.57	1.14		3.80	3.80	15.0	83.0	60.0	315.5	60.0	Conc.	250	254	6.00	93.0	152.0	3.00	0.52		
	118	115						0.00	3.80	15.5	15.5	81.0	307.7	60.0	Conc.	200	203	0.80	90.0	30.8	0.94	1.60		
	115	101						0.00	3.80	17.1	17.1	75.4	286.5	60.0	Conc.	200	203	0.30	90.0	18.7				
	101	Outlet						0.00	30.96	16.2	16.2	78.5	60.0	2429.1	418.6	Conc.	750	762	0.40	72.0	734.5	1.61	0.75	
Total				0.86	0.41	0.57	11.90																	

Shaded area show pipe segments that will surcharge during storms less than 1:5 years.

Should have been  
 $351.0 + 60 = 411.0$

This number is incorrect, added  
 $178.6 + 20 + 40 = 238.6$

Recommended Pipe size in front of the grandsatnd.

Area	From MH	To MH	Roof Flow (L/s)	Roof Area (ha)	AREA (ha)			Ind. 2.78AR	Accum. 2.78AR	Time of Conc. (min)	Rainfall Intensity (mm/hr) (I)	Flow Restriction (L/s)	Peak Flow Q(L/sec)	Flow in Sewer (L/s)	Type of Pipe	SEWER DATA			Capacity (L/sec)	Velocity (m/sec)	Time of Flow (min)	REMARKS	
					0.2	0.6	0.9									Diameter (mm) (nom.)	(act.)	Slope (%)					Length (m)
	117	116						0.63	1.10	3.80	7.60	15.0	83.0	60.0	Conc.	250	254	6.00	93.0	152.0	3.00	0.52	
	116	115						0.00	7.60	15.5	15.5	81.0	615.5	60.0	Conc.	300	305	0.50	90.0	71.3	0.98	1.53	
	115	101						0.00	7.60	17.1	17.1	75.6	574.8	60.0	Conc.	300	305	0.50	90.0	71.3			

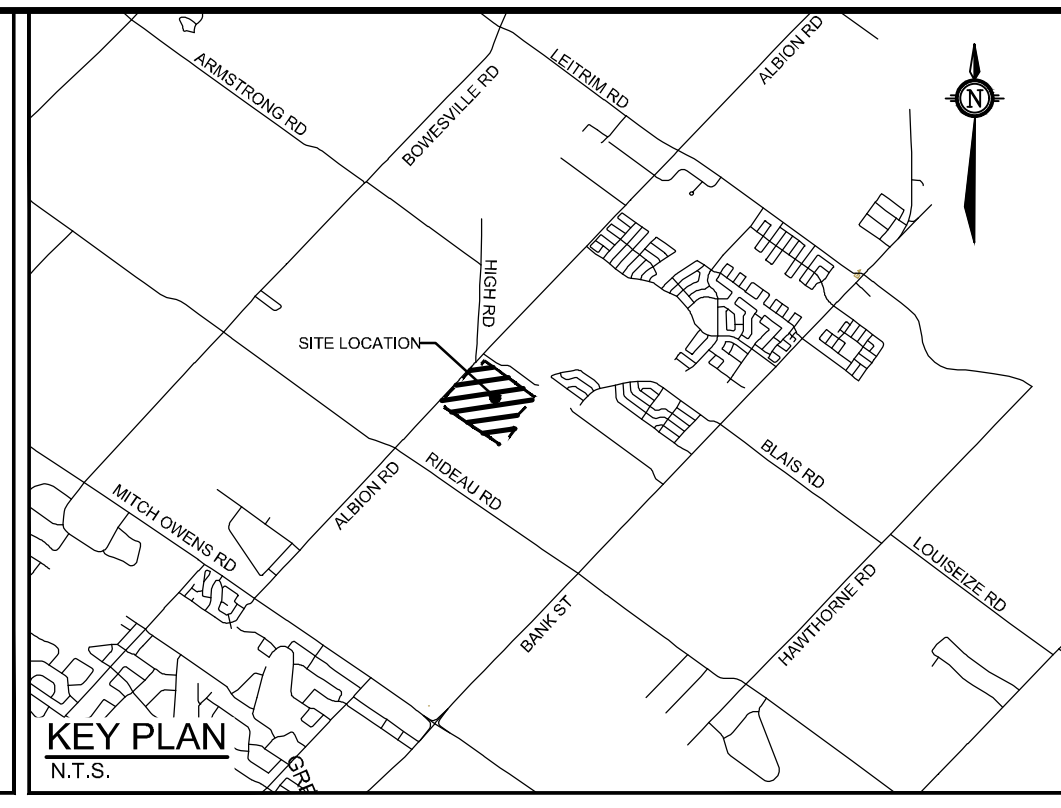
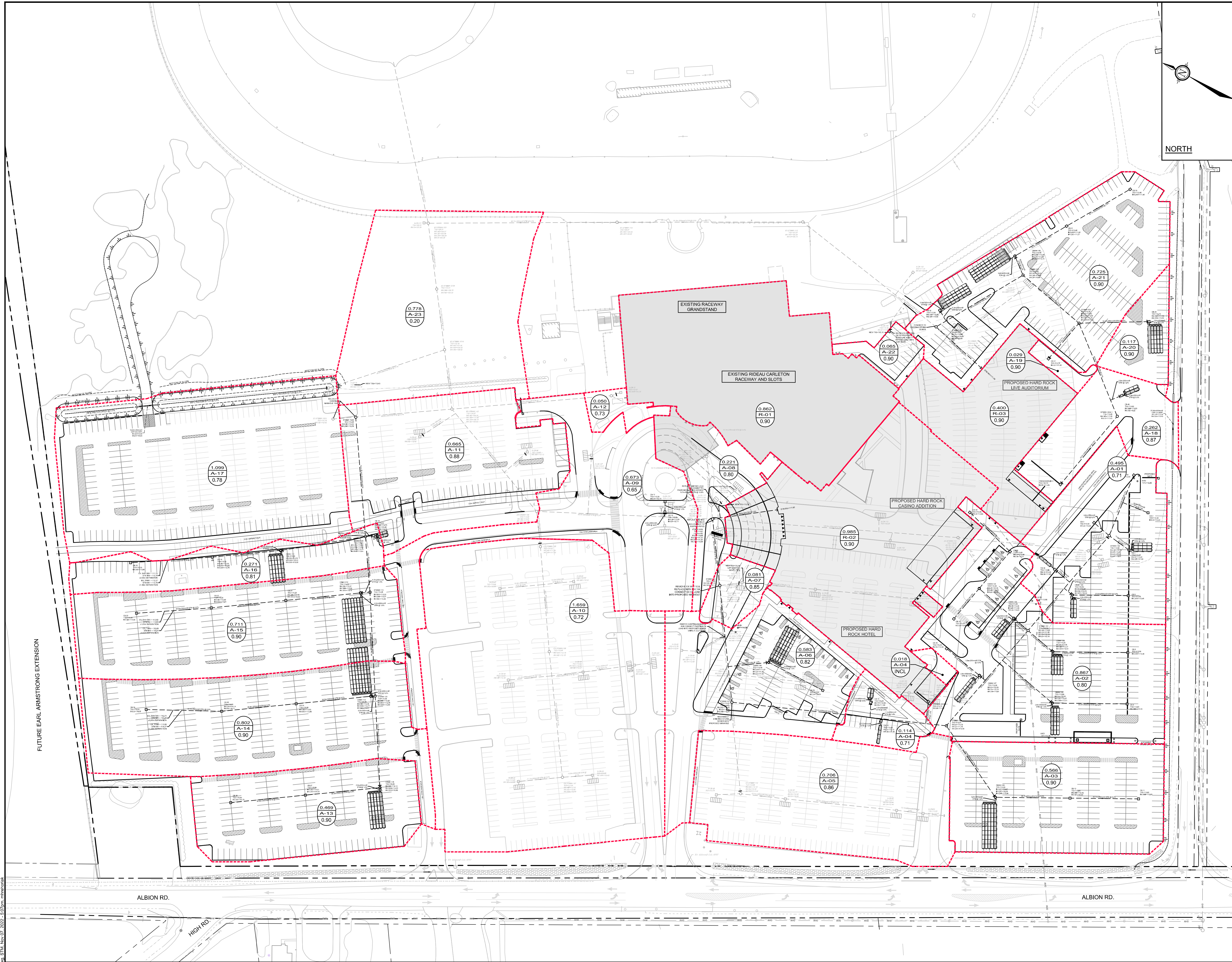

- LEGEND**
- PROPERTY LINE
  - PROPOSED STORM SEWER AND MANHOLE
  - ▶ DIRECTION OF FLOW
  - PROPOSED CATCHBASIN MANHOLE
  - PROPOSED CATCHBASIN
  - EXISTING STORM MANHOLE & SEWER
  - EXISTING CATCHBASIN
  - - - - - STORM SEWER DRAINAGE AREA BOUNDARY
  - 0.086 A-16 0.78 DRAINAGE AREA (ha)
  - 0.086 A-16 0.78 DRAINAGE AREA ID
  - 0.086 A-16 0.78 RUNOFF COEFFICIENT

NOTE:  
 THE POSITION OF ALL POLE LINES, CONDUITS,  
 WATERMANS, SEWERS AND OTHER  
 UNDERGROUND AND OVERGROUND UTILITIES AND  
 STRUCTURES IS NOT NECESSARILY SHOWN ON  
 THE CONTRACT DRAWINGS, AND WHERE SHOWN,  
 THE ACCURACY OF THE POSITION OF SUCH  
 UTILITIES AND STRUCTURES IS NOT GUARANTEED.  
 BEFORE STARTING WORK, DETERMINE THE EXACT  
 LOCATION OF ALL SUCH UTILITIES AND  
 STRUCTURES AND ASSUME ALL LIABILITY FOR  
 DAMAGE TO THEM.

No.	REVISION	DATE	BY
3	REVISED PER CITY COMMENTS	NOV 07/22	MJH
2	REVISED PER CITY COMMENTS	APR 24/20	CJR
1	ISSUED FOR SITE PLAN APPROVAL	NOV 20/19	CJR

SCALE	DESIGN	CHECKED	DRAWN	APPROVED
1:750	MJH	MJH	MJH	JLS

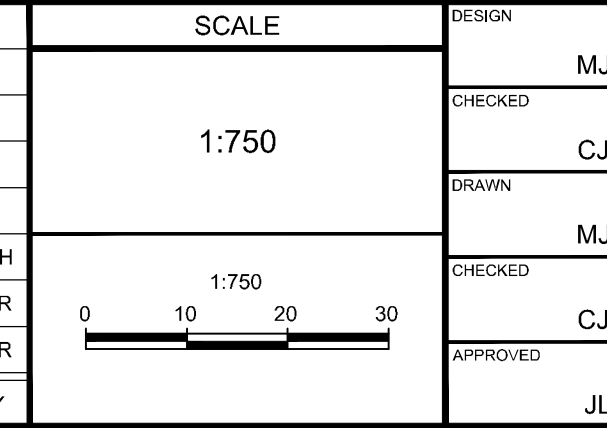

**FOR REVIEW ONLY**

PROFESSIONAL ENGINEER  
 M. J. BREWSTER  
 10021256  
 NOV 7/22  
 PROVINCE OF ONTARIO

**NOVATECH**  
 Engineers, Planners & Landscape Architects  
 Suite 200, 240 Michael Cowpland Drive  
 Ottawa, Ontario, Canada K2M 1P6  
 Telephone: (613) 254-9643  
 Facsimile: (613) 254-5867  
 Website: www.novatech-eng.com

LOCATION  
 4837 ALBION ROAD, CITY OF OTTAWA  
 HARD ROCK OTTAWA

DRAWING NAME  
**STORM SEWER DRAINAGE  
 AREA PLAN**

PROJECT No. 116111  
 REV # 3  
 DRAWING No. 116111-STM

**2 Year Storm Sewer Design Sheet**

LOCATION			AREA (Ha)				FLOW					PROPOSED SEWER										
AREA ID	FROM	TO	TOTAL AREA (ha)	R= 0.2	R= 0.9	R	INDIV 2.78 AR	ACCUM 2.78 AR	TIME OF CONC.	RAINFALL INTENSITY I	PEAK FLOW Q (l/s)	CONTROLLED FLOW (2-YEAR) Q <sub>controlled</sub> (l/s)	PIPE SIZE (mm)	PIPE SLOPE (%)	LENGTH (m)	CAPACITY (l/s)	FULL FLOW VELOCITY (m/s)	TIME OF FLOW (min.)	EXCESS CAPACITY (l/s)	Q/Q <sub>full</sub>	Q <sub>controlled</sub> /Q <sub>full</sub>	
A-01	STMMH 100	STMMH 101	0.495	0.132	0.363	0.71	0.98	0.98	10.00	76.81	75.39	14.0	457.2	0.30	61.3	163.08	0.99	1.03	87.68	0.46	0.09	
A-02	STMMH 101	STMMH 102	0.867	0.119	0.748	0.80	1.94	2.92	11.03	73.07	213.30	36.5	457.2	0.30	61.6	163.08	0.99	1.03	-50.22	1.31	0.22	
A-03	CBMH 109	STMMH 102	0.566	0.000	0.566	0.90	1.42	1.42	10.00	76.81	108.77	8.8	304.8	0.50	42.5	71.41	0.98	0.72	-37.36	1.52	0.12	
A-04	STMMH 102	STMMH 103	0.132	0.035	0.096	0.71	0.26	4.60	12.06	69.69	320.32	49.0	533.0	0.30	106.0	245.50	1.10	1.61	-74.82	1.30	0.20	
A-05	EX STMMH 112	STMMH 103	0.706	0.044	0.662	0.86	1.68	1.68	10.00	76.81	129.09	91.8	304.8	0.10	45.1	31.93	0.44	1.72	-97.16	4.04	2.87	
A-06	STMMH 103	STMMH 104	0.583	0.067	0.516	0.82	1.33	7.60	13.67	65.09	495.02	157.7	610.0	0.30	57.6	351.82	1.20	0.80	-143.20	1.41	0.45	
A-07	STMMH 104	STMMH X109	0.081	0.006	0.075	0.85	0.19	7.80	14.47	63.05	491.50	162.3	610.0	0.30	32.8	351.82	1.20	0.45	-139.69	1.40	0.46	
R-01	EXSTMMH 108	STMMH X109	0.862	0.000	0.862	0.90	2.16	2.16	10.00	76.81	165.65	100.1	381.0	1.10	32.9	192.03	1.68	0.33	26.39	0.86	0.52	
R-02	Building Service	STMMH X109	0.985	0.000	0.985	0.90	Controlled 100-year flow from roof drains = 77.6 L/s				77.60	52.2										
A-08	Building Service	STMMH X109	0.221	0.030	0.191	0.80	0.49	0.49	10.00	76.81	115.58	64.7	304.8	1.00	32.2	100.98	1.38	0.39	-14.60	1.14	0.64	
A-09	STMMH X109	EX STMMH 104	0.673	0.242	0.431	0.65	1.21	11.66	14.92	61.95	799.89	374.3	610.0	0.30	86.3	351.82	1.20	1.20	-448.08	2.27	1.06	
A-10	EX STMMH 105	EX STMMH 104	1.659	0.432	1.227	0.72	3.31	3.31	10.00	76.81	254.24	108.2	457.2	0.20	17.4	133.15	0.81	0.36	-121.09	1.91	0.81	
A-11	EX STMMH 104	EX STMMH 102	0.665	0.019	0.646	0.88	1.63	16.60	16.12	59.24	1060.87	577.9	610.0	1.30	65.3	732.37	2.50	0.43	-328.50	1.45	0.79	
A-12	EX STMMH 103	EX STMMH 102	0.050	0.012	0.038	0.73	0.10	0.10	10.00	76.81	7.81	7.8	304.8	1.10	78.6	105.91	1.45	0.90	98.10	0.07	0.07	
A-13	CBMH 115	STMMH 120	0.469	0.000	0.469	0.90	1.17	1.17	10.00	76.81	90.13	8.3	304.8	1.00	45.1	100.98	1.38	0.54	10.86	0.89	0.08	
A-14	STMMH 120	STMMH 113	0.802	0.000	0.802	0.90	2.01	3.18	10.54	74.78	237.80	17.9	304.8	0.80	51.0	90.32	1.24	0.69	-147.48	2.63	0.20	
A-15	STMMH 113	STMMH 119	0.711	0.000	0.711	0.90	1.78	4.96	11.23	72.38	358.93	25.0	304.8	1.00	51.0	100.98	1.38	0.61	-257.95	3.55	0.25	
A-16	STMMH119	EX STMH 102A	0.271	0.035	0.236	0.81	0.61	5.57	11.85	70.38	391.92	32.2	304.8	1.00	86.3	100.98	1.38	1.04	-290.94	3.88	0.32	
	EX STMH 102A	EX STMMH 102	0.000	0.000	0.000	0.00	0.00	5.57	12.89	67.25	374.53	32.2	304.8	0.90	59.0	95.80	1.31	0.75	-278.72	3.91	0.34	
	EX STMMH 102	EX STMMH 101A	0.000	0.000	0.000	0.00	0.00	22.27	16.56	58.33	1376.37	607.1	762.0	1.60	29.4	1470.57	3.22	0.15	94.20	0.94	0.41	
A-17	EX STMMH 101A	EX STMMH 101B	1.099	0.191	0.908	0.78	2.38	24.65	16.71	58.01	1507.33	661.0	762.0	1.40	30.1	1375.59	3.01	0.17	-131.74	1.10	0.48	
	EX STMMH 101B	EX STMMH 101	0.000	0.000	0.000	0.00	0.00	24.65	16.87	57.67	1498.97	661.0	762.0	2.30	32.6	1763.15	3.86	0.14	264.18	0.85	0.37	
A-18	OGS 1	STMMH 123	0.262	0.011	0.251	0.87	0.63	0.63	10.00	76.81	48.70	32.1	304.8	0.50	49.4	71.41	0.98	0.84	22.70	0.68	0.45	
A-19	CB 41	STMMH 123	0.029	0.000	0.029	0.90	0.07	0.07	10.00	76.81	5.57	5.6	254.0	0.50	23.0	43.91	0.87	0.44	38.34	0.13	0.13	
A-20	CB 29	STMMH 123	0.117	0.000	0.117	0.90	0.29	0.29	10.00	76.81	22.48	2.4	254.0	0.50	34.4	43.91	0.87	0.66	21.43	0.51	0.05	
	STMMH 123	STMMH 117	0.000	0.000	0.000	0.00	0.00	1.00	10.84	73.72	73.67	39.6	304.8	0.50	36.2	71.41	0.98	0.62	-2.27	1.03	0.55	
A-21	STMMH 117	STMMH 116	0.725	0.000	0.725	0.90	1.81	2.81	11.46	71.62	201.50	59.8	304.8	0.50	49.7	71.41	0.98	0.85	-130.09	2.82	0.84	
R-03	Building Service	STMMH 116	0.400	0.000	0.400	0.90	Controlled 100-year flow from roof / trench drains = 37.9 L/s				37.90	24.9	254.0	2.00	30.0	87.82	1.73	0.29	49.92	0.43	0.28	
A-22	STMMH 116	EX STMMH 116	0.065	0.000	0.065	0.90	0.16	2.98	12.31	68.95	243.11	94.7	254.0	5.90	93.9	150.84	2.97	0.53	-92.26	1.61	0.63	
	EX STMMH 116	EX STMMH 115	0.000	0.000	0.000	0.00	0.00	2.98	12.83	67.41	238.50	81.5	304.8	0.50	91.3	71.41	0.98	1.56	-167.09	3.34	1.14	
	EX STMMH 115	EX STMMH 101	0.000	0.000	0.000	0.00	0.00	2.98	14.39	63.25	226.12	80.5	304.8	0.50	92.7	71.41	0.98	1.58	-154.72	3.17	1.13	
A-23	EX STMMH 101	POND	0.778	0.778	0.000	0.20	0.43	28.05	17.01	57.39	1725.50	729.6	762.0	2.00	80.9	1644.14	3.60	0.37	-81.36	1.05	0.44	

\*Note: Storm sewer design sheet flows are peak uncontrolled flows. Flows will be attenuated with ICD's which will increase the excess capacity in the pipes

**Definitions**  
 Q = 2.78 AIR  
 Q = Peak Flow, in Litres per second (L/s)  
 A = Area in hectares (ha)  
 I = 2 YEAR Rainfall Intensity (mm/h)  
 R = Runoff Coefficient

**Notes:**  
 1) Ottawa Rainfall-Intensity Curve  
 2) Min Velocity = 0.76 m/sec.  
 3) 2 Year intensity =  $732.951 / (time + 6.199)^{0.810}$

M:\2016\116111\CAD\Design\116111-ROOF.dwg, Nov 03, 2022 - 2:41pm, dmaratha

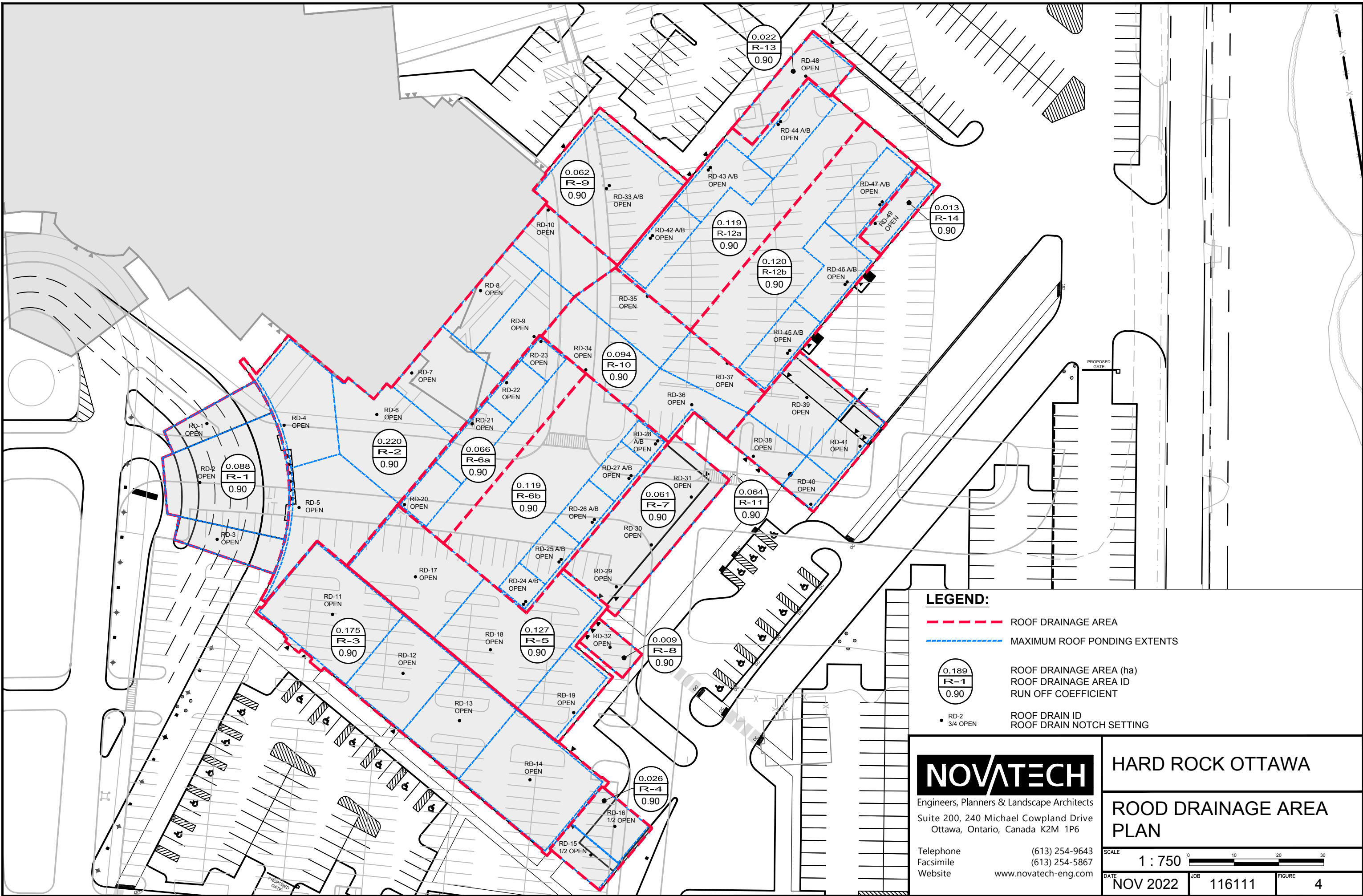

**LEGEND:**

- - - ROOF DRAINAGE AREA
- - - MAXIMUM ROOF PONDING EXTENTS
- |            |
|------------|
| 0.189      |
| <b>R-1</b> |
| 0.90       |

 ROOF DRAINAGE AREA (ha)  
 ROOF DRAINAGE AREA ID  
 RUN OFF COEFFICIENT
- |          |
|----------|
| RD-2     |
| 3/4 OPEN |

 ROOF DRAIN ID  
 ROOF DRAIN NOTCH SETTING

**NOVATECH**

Engineers, Planners & Landscape Architects  
Suite 200, 240 Michael Cowpland Drive  
Ottawa, Ontario, Canada K2M 1P6

Telephone (613) 254-9643  
Facsimile (613) 254-5867  
Website www.novatech-eng.com

**HARD ROCK OTTAWA**

**ROOD DRAINAGE AREA PLAN**

SCALE 1 : 750

DATE NOV 2022 JOB 116111 FIGURE 4

**PORT COCHERE ROOF**

**TABLE 1A: Post-Development Runoff Coefficient "C" - R1 Controlled Roof Area**

Area	Surface	Ha	5 Year Event		100 Year Event	
			"C"	C <sub>avg</sub>	"C" + 25%	*C <sub>avg</sub>
Total	Hard	0.000	0.90	0.90	1.00	1.00
0.088	Roof	0.088	0.90		1.00	
	Soft	0.000	0.20		0.25	

**TABLE 1B: 5 YEAR EVENT QUANTITY STORAGE REQUIREMENT - R1 Controlled Roof Area**

0.088 =Area (ha)  
 0.90 = C

Return Period	Time (min)	Intensity (mm/hr)	Flow Q (L/s)	Allowable Runoff (L/s)	Net Flow to be Stored (L/s)	Storage Req'd (m <sup>3</sup> )
5 YEAR	25	60.90	13.41	3.3	10.10	15.14
	30	53.93	11.87	3.3	8.56	15.41
	<b>35</b>	<b>48.52</b>	<b>10.68</b>	<b>3.3</b>	<b>7.37</b>	<b>15.48</b>
	40	44.18	9.73	3.3	6.42	15.40
	45	40.63	8.95	3.3	5.63	15.21

**TABLE 1C: 100 YEAR EVENT QUANTITY STORAGE REQUIREMENT - R1 Controlled Roof Area**

0.088 =Area (ha)  
 1.00 = C

Return Period	Time (min)	Intensity (mm/hr)	Flow Q (L/s)	Allowable Runoff (L/s)	Net Flow to be Stored (L/s)	Storage Req'd (m <sup>3</sup> )
100 YEAR	25	103.85	25.41	5.7	19.73	29.59
	30	91.87	22.47	5.7	16.80	30.23
	<b>35</b>	<b>82.58</b>	<b>20.20</b>	<b>5.7</b>	<b>14.52</b>	<b>30.50</b>
	40	75.15	18.38	5.7	12.71	30.49
	45	69.05	16.89	5.7	11.21	30.28

Equations:

Flow Equation

$$Q = 2.78 \times C \times I \times A$$

Where:

C is the runoff coefficient

I is the rainfall intensity, City of Ottawa IDF

A is the total drainage area

Runoff Coefficient Equation

$$C_s = (A_{\text{hard}} \times 0.9 + A_{\text{soft}} \times 0.2) / A_{\text{Tot}}$$

$$C_{100} = (A_{\text{hard}} \times 1.0 + A_{\text{soft}} \times 0.25) / A_{\text{Tot}}$$

**Table 1D: Roof Drain Flows**

Roof Drains	
Roof Area	880 m <sup>2</sup>
Qty	3
Type	Accutrol RD-100-A-ADJ
Setting	Fully Open
Design Head	0.05-0.15 m
Design Flow 1" of head	0.32 L/s (ea)
Design Flow 2" of head	0.63 L/s (ea)
Design Flow 3" of head	0.95 L/s (ea)
Design Flow 4" of head	1.26 L/s (ea)
Design Flow 5" of head	1.58 L/s (ea)
Design Flow 6" of head	1.89 L/s (ea)

**Table 1E: Total Roof Storage**

Storm Event	Roof Drain ID	**Avg Area Per Roof Drain (m <sup>2</sup> )	Avg Ponding Depth Per Roof Drain (m)	*Total Volume (m <sup>3</sup> )	Total Volume (m <sup>3</sup> ) Required
5 Year	RD-1	155	0.089	4.61	-
	RD-2	566	0.089	16.77	-
	RD-3	159	0.089	4.71	-
<b>Total</b>				<b>26.08</b>	<b>15.48</b>
100 Year	RD-1	155	0.152	7.89	-
	RD-2	566	0.152	28.74	-
	RD-3	159	0.152	8.07	-
<b>Total</b>				<b>44.70</b>	<b>30.50</b>

\*Note: Ponding volumes calculated using cone equation:

$$V = \frac{\text{Area} \times \text{Depth}}{3}$$

**LOWER CASINO ROOF**

**TABLE 1A: Post-Development Runoff Coefficient "C" - R2 Controlled Roof Area**

Area	Surface	Ha	5 Year Event		100 Year Event	
			"C"	C <sub>avg</sub>	"C" + 25%	*C <sub>avg</sub>
Total	Hard	0.000	0.90	0.90	1.00	1.00
0.220	Roof	0.220	0.90			
	Soft	0.000	0.20		0.25	

**TABLE 1B: 5 YEAR EVENT QUANTITY STORAGE REQUIREMENT - R2 Controlled Roof Area**

0.22 = Area (ha)  
 0.90 = C

Return Period	Time (min)	Intensity (mm/hr)	Flow Q (L/s)	Allowable Runoff (L/s)	Net Flow to be Stored (L/s)	Storage Req'd (m <sup>3</sup> )
5 YEAR	25	60.90	33.52	7.7	25.79	38.69
	30	53.93	29.68	7.7	21.96	39.52
	<b>35</b>	<b>48.52</b>	<b>26.71</b>	<b>7.7</b>	<b>18.98</b>	<b>39.85</b>
	40	44.18	24.32	7.7	16.59	39.82
	45	40.63	22.36	7.7	14.63	39.51

**TABLE 1C: 100 YEAR EVENT QUANTITY STORAGE REQUIREMENT - R2 Controlled Roof Area**

0.22 = Area (ha)  
 1.00 = C

Return Period	Time (min)	Intensity (mm/hr)	Flow Q (L/s)	Allowable Runoff (L/s)	Net Flow to be Stored (L/s)	Storage Req'd (m <sup>3</sup> )
100 YEAR	30	91.87	56.19	13.2	42.94	77.29
	35	82.58	50.51	13.2	37.26	78.24
	<b>40</b>	<b>75.15</b>	<b>45.96</b>	<b>13.2</b>	<b>32.71</b>	<b>78.50</b>
	45	69.05	42.23	13.2	28.98	78.25
	50	63.95	39.11	13.2	25.87	77.60

Equations:

Flow Equation

$$Q = 2.78 \times C \times I \times A$$

Where:

C is the runoff coefficient

I is the rainfall intensity, City of Ottawa IDF

A is the total drainage area

Runoff Coefficient Equation

$$C_s = (A_{\text{hard}} \times 0.9 + A_{\text{soft}} \times 0.2) / A_{\text{Tot}}$$

$$C_{100} = (A_{\text{hard}} \times 1.0 + A_{\text{soft}} \times 0.25) / A_{\text{Tot}}$$

**Table 1D: Roof Drain Flows**

Roof Drains		
Roof Area	2200	m <sup>2</sup>
Qty	7	
Type	Accutrol RD-100-A-ADJ	
Setting	Fully Open	
Design Head	0.05-0.15	m
Design Flow 1" of head	0.32	L/s (ea)
Design Flow 2" of head	0.63	L/s (ea)
Design Flow 3" of head	0.95	L/s (ea)
Design Flow 4" of head	1.26	L/s (ea)
Design Flow 5" of head	1.58	L/s (ea)
Design Flow 6" of head	1.89	L/s (ea)

**Table 1E: Total Roof Storage**

Storm Event	Roof Drain ID	**Avg Area Per Roof Drain (m <sup>2</sup> )	Avg Ponding Depth Per Roof Drain (m)	*Total Volume (m <sup>3</sup> )	Total Volume (m <sup>3</sup> ) Required
5 Year	RD-4	319.1	0.089	9.46	-
	RD-5	415.7	0.089	12.32	-
	RD-6	434.0	0.089	12.86	-
	RD-7	311.6	0.089	9.23	-
	RD-8	213.6	0.089	6.33	-
	RD-9	218.8	0.089	6.48	-
	RD-10	229.0	0.089	6.79	-
<b>Total</b>				<b>63.47</b>	<b>39.85</b>
100 Year	RD-4	319.1	0.152	16.21	-
	RD-5	415.7	0.152	21.12	-
	RD-6	434.0	0.152	22.05	-
	RD-7	311.6	0.152	15.83	-
	RD-8	213.6	0.152	10.85	-
	RD-9	218.8	0.152	11.12	-
	RD-10	229.0	0.152	11.63	-
<b>Total</b>				<b>108.80</b>	<b>78.50</b>



**HOTEL ROOF**

**TABLE 1A: Post-Development Runoff Coefficient "C" - R3 Controlled Roof Area**

Area	Surface	Ha	5 Year Event		100 Year Event	
			"C"	C <sub>avg</sub>	"C" + 25%	*C <sub>avg</sub>
Total	Hard	0.000	0.90	0.90	1.00	1.00
0.175	Roof	0.175	0.90			
	Soft	0.000	0.20		0.25	

**TABLE 1B: 5 YEAR EVENT QUANTITY STORAGE REQUIREMENT - R3 Controlled Roof Area**

0.175 =Area (ha)  
 0.90 = C

Return Period	Time (min)	Intensity (mm/hr)	Flow Q (L/s)	Allowable Runoff (L/s)	Net Flow to be Stored (L/s)	Storage Req'd (m <sup>3</sup> )
5 YEAR	40	44.18	19.35	4.4	14.93	35.83
	45	40.63	17.79	4.4	13.37	36.11
	<b>50</b>	<b>37.65</b>	<b>16.49</b>	<b>4.4</b>	<b>12.07</b>	<b>36.21</b>
	55	35.12	15.38	4.4	10.96	36.18
	60	32.94	14.42	4.4	10.01	36.03

**TABLE 1C: 100 YEAR EVENT QUANTITY STORAGE REQUIREMENT - R3 Controlled Roof Area**

0.175 =Area (ha)  
 1.00 = C

Return Period	Time (min)	Intensity (mm/hr)	Flow Q (L/s)	Allowable Runoff (L/s)	Net Flow to be Stored (L/s)	Storage Req'd (m <sup>3</sup> )
100 YEAR	45	69.05	33.59	7.6	26.02	70.26
	50	63.95	31.11	7.6	23.54	70.63
	<b>55</b>	<b>59.62</b>	<b>29.01</b>	<b>7.6</b>	<b>21.44</b>	<b>70.74</b>
	60	55.89	27.19	7.6	19.62	70.64
	65	52.65	25.61	7.6	18.04	70.36

Equations:

Flow Equation

$$Q = 2.78 \times C \times I \times A$$

Where:

C is the runoff coefficient

I is the rainfall intensity, City of Ottawa IDF

A is the total drainage area

Runoff Coefficient Equation

$$C_s = (A_{hard} \times 0.9 + A_{soft} \times 0.2) / A_{Tot}$$

$$C_{100} = (A_{hard} \times 1.0 + A_{soft} \times 0.25) / A_{Tot}$$

**Table 1D: Roof Drain Flows**

Roof Drains		
Roof Area	1750	m <sup>2</sup>
Qty	4	
Type	Accutrol RD-100-A-ADJ	
Setting	Fully Open	
Design Head	0.05-0.15	m
Design Flow 1" of head	0.32	L/s (ea)
Design Flow 2" of head	0.63	L/s (ea)
Design Flow 3" of head	0.95	L/s (ea)
Design Flow 4" of head	1.26	L/s (ea)
Design Flow 5" of head	1.58	L/s (ea)
Design Flow 6" of head	1.89	L/s (ea)

**Table 1E: Total Roof Storage**

Storm Event	Roof Drain ID	**Avg Area Per Roof Drain (m <sup>2</sup> )	Avg Ponding Depth Per Roof Drain (m)	*Total Volume (m <sup>3</sup> )	Total Volume (m <sup>3</sup> ) Required
5 Year	RD-11	503.8	0.089	14.93	-
	RD-12	327.9	0.089	9.72	-
	RD-13	327.9	0.089	9.72	-
	RD-14	501.0	0.089	14.85	-
<b>Total</b>				<b>49.21</b>	<b>36.21</b>
100 Year	RD-11	503.8	0.152	25.59	-
	RD-12	327.9	0.152	16.66	-
	RD-13	327.9	0.152	16.66	-
	RD-14	501.0	0.152	25.45	-
<b>Total</b>				<b>84.36</b>	<b>70.74</b>

\*Note: Ponding volumes calculated using cone equation:

$$V = \frac{Area \times Depth}{3}$$

**HOTEL DOCK SOUTH**

**TABLE 1A: Post-Development Runoff Coefficient "C" - R4 Controlled Roof Area**

Area	Surface	Ha	5 Year Event		100 Year Event	
			"C"	C <sub>avg</sub>	"C" + 25%	*C <sub>avg</sub>
Total	Hard	0.000	0.90	0.90	1.00	1.00
0.026	Roof	0.026	0.90		1.00	
	Soft	0.000	0.20		0.25	

**TABLE 1B: 5 YEAR EVENT QUANTITY STORAGE REQUIREMENT - R4 Controlled Roof Area**

0.026 =Area (ha)  
 0.90 = C

Return Period	Time (min)	Intensity (mm/hr)	Flow Q (L/s)	Allowable Runoff (L/s)	Net Flow to be Stored (L/s)	Storage Req'd (m <sup>3</sup> )
5 YEAR	5	141.18	9.18	2.2	6.98	2.09
	10	104.19	6.78	2.2	4.57	2.74
	<b>15</b>	<b>83.56</b>	<b>5.44</b>	<b>2.2</b>	<b>3.23</b>	<b>2.90</b>
	20	70.25	4.57	2.2	2.36	2.83
	25	60.90	3.96	2.2	1.75	2.63

**TABLE 1C: 100 YEAR EVENT QUANTITY STORAGE REQUIREMENT - R4 Controlled Roof Area**

0.026 =Area (ha)  
 1.00 = C

Return Period	Time (min)	Intensity (mm/hr)	Flow Q (L/s)	Allowable Runoff (L/s)	Net Flow to be Stored (L/s)	Storage Req'd (m <sup>3</sup> )
100 YEAR	5	242.70	17.54	3.8	13.76	4.13
	10	178.56	12.91	3.8	9.12	5.47
	<b>15</b>	<b>142.89</b>	<b>10.33</b>	<b>3.8</b>	<b>6.54</b>	<b>5.89</b>
	20	119.95	8.67	3.8	4.88	5.86
	25	103.85	7.51	3.8	3.72	5.58

Equations:

Flow Equation

$$Q = 2.78 \times C \times I \times A$$

Where:

C is the runoff coefficient

I is the rainfall intensity, City of Ottawa IDF

A is the total drainage area

Runoff Coefficient Equation

$$C_s = (A_{\text{hard}} \times 0.9 + A_{\text{soft}} \times 0.2) / A_{\text{Tot}}$$

$$C_{100} = (A_{\text{hard}} \times 1.0 + A_{\text{soft}} \times 0.25) / A_{\text{Tot}}$$

**Table 1D: Roof Drain Flows**

Roof Drains		
Roof Area	260	m <sup>2</sup>
Qty	2	
Type	Accutrol RD-100-A-ADJ	
Setting	Fully Open	
Design Head	0.05-0.15	m
Design Flow 1" of head	0.32	L/s (ea)
Design Flow 2" of head	0.63	L/s (ea)
Design Flow 3" of head	0.95	L/s (ea)
Design Flow 4" of head	1.26	L/s (ea)
Design Flow 5" of head	1.58	L/s (ea)
Design Flow 6" of head	1.89	L/s (ea)

**Table 1E: Total Roof Storage**

Storm Event	Roof Drain ID	**Avg Area Per Roof Drain (m <sup>2</sup> )	Avg Ponding Depth Per Roof Drain (m)	*Total Volume (m <sup>3</sup> )	Total Volume (m <sup>3</sup> ) Required
5 Year	RD-15	101.9	0.089	3.02	-
	RD-16	143.9	0.089	4.26	-
<b>Total</b>				<b>7.28</b>	<b>2.90</b>
100 Year	RD-15	101.9	0.152	5.18	-
	RD-16	143.9	0.152	7.31	-
<b>Total</b>				<b>12.49</b>	<b>5.89</b>

\*Note: Ponding volumes calculated using cone equation:

$$V = \frac{\text{Area} \times \text{Depth}}{3}$$

**CASINO ROOF**

**TABLE 1A: Post-Development Runoff Coefficient "C" - R5 Controlled Roof Area**

Area	Surface	Ha	5 Year Event		100 Year Event	
			"C"	C <sub>avg</sub>	"C" + 25%	*C <sub>avg</sub>
Total	Hard	0.000	0.90	0.90	1.00	1.00
0.127	Roof	0.127	0.90		1.00	
	Soft	0.000	0.20		0.25	

**TABLE 1B: 5 YEAR EVENT QUANTITY STORAGE REQUIREMENT - R5 Controlled Roof Area**

0.127 =Area (ha)  
 0.90 = C

Return Period	Time (min)	Intensity (mm/hr)	Flow Q (L/s)	Allowable Runoff (L/s)	Net Flow to be Stored (L/s)	Storage Req'd (m <sup>3</sup> )
5 YEAR	40	44.18	14.04	3.3	10.73	25.75
	45	40.63	12.91	3.3	9.60	25.91
	<b>50</b>	<b>37.65</b>	<b>11.96</b>	<b>3.3</b>	<b>8.65</b>	<b>25.96</b>
	55	35.12	11.16	3.3	7.85	25.90
	60	32.94	10.47	3.3	7.16	25.76

**TABLE 1C: 100 YEAR EVENT QUANTITY STORAGE REQUIREMENT - R5 Controlled Roof Area**

0.127 =Area (ha)  
 1.00 = C

Return Period	Time (min)	Intensity (mm/hr)	Flow Q (L/s)	Allowable Runoff (L/s)	Net Flow to be Stored (L/s)	Storage Req'd (m <sup>3</sup> )
100 YEAR	45	69.05	24.38	5.7	18.70	50.49
	50	63.95	22.58	5.7	16.90	50.70
	<b>55</b>	<b>59.62</b>	<b>21.05</b>	<b>5.7</b>	<b>15.37</b>	<b>50.73</b>
	60	55.89	19.73	5.7	14.06	50.60
	65	52.65	18.59	5.7	12.91	50.35

Equations:

Flow Equation

$$Q = 2.78 \times C \times I \times A$$

Where:

C is the runoff coefficient

I is the rainfall intensity, City of Ottawa IDF

A is the total drainage area

Runoff Coefficient Equation

$$C_s = (A_{\text{hard}} \times 0.9 + A_{\text{soft}} \times 0.2) / A_{\text{Tot}}$$

$$C_{100} = (A_{\text{hard}} \times 1.0 + A_{\text{soft}} \times 0.25) / A_{\text{Tot}}$$

**Table 1D: Roof Drain Flows**

Roof Drains		
Roof Area	1270	m <sup>2</sup>
Qty	3	
Type	Accutrol RD-100-A-ADJ	
Setting	Fully Open	
Design Head	0.05-0.15	m
Design Flow 1" of head	0.32	L/s (ea)
Design Flow 2" of head	0.63	L/s (ea)
Design Flow 3" of head	0.95	L/s (ea)
Design Flow 4" of head	1.26	L/s (ea)
Design Flow 5" of head	1.58	L/s (ea)
Design Flow 6" of head	1.89	L/s (ea)

**Table 1E: Total Roof Storage**

Storm Event	Roof Drain ID	**Avg Area Per Roof Drain (m <sup>2</sup> )	Avg Ponding Depth Per Roof Drain (m)	*Total Volume (m <sup>3</sup> )	Total Volume (m <sup>3</sup> ) Required
5 Year	RD-17	439	0.089	13.01	-
	RD-18	574	0.089	17.01	-
	RD-19	195	0.089	5.78	-
<b>Total</b>				<b>35.80</b>	<b>25.96</b>
100 Year	RD-17	439	0.152	22.30	-
	RD-18	574	0.152	29.16	-
	RD-19	195	0.152	9.92	-
<b>Total</b>				<b>61.37</b>	<b>50.73</b>

\*Note: Ponding volumes calculated using cone equation:

$$V = \frac{\text{Area} \times \text{Depth}}{3}$$

**HIGH CASINO ROOF**

**TABLE 1A: Post-Development Runoff Coefficient "C" - R6a Controlled Roof Area**

Area	Surface	Ha	5 Year Event		100 Year Event	
			"C"	C <sub>avg</sub>	"C" + 25%	*C <sub>avg</sub>
Total	Hard	0.000	0.90	0.90	1.00	1.00
0.066	Roof	0.066	0.90		1.00	
	Soft	0.000	0.20		0.25	

**TABLE 1B: 5 YEAR EVENT QUANTITY STORAGE REQUIREMENT - R6a Controlled Roof Area**

0.066 =Area (ha)  
 0.90 = C

Return Period	Time (min)	Intensity (mm/hr)	Flow Q (L/s)	Allowable Runoff (L/s)	Net Flow to be Stored (L/s)	Storage Req'd (m <sup>3</sup> )
5 YEAR	10	104.19	17.21	4.4	12.79	7.67
	15	83.56	13.80	4.4	9.38	8.44
	<b>20</b>	<b>70.25</b>	<b>11.60</b>	<b>4.4</b>	<b>7.18</b>	<b>8.62</b>
	25	60.90	10.06	4.4	5.64	8.46
	30	53.93	8.91	4.4	4.49	8.08

**TABLE 1C: 100 YEAR EVENT QUANTITY STORAGE REQUIREMENT - R6a Controlled Roof Area**

0.066 =Area (ha)  
 1.00 = C

Return Period	Time (min)	Intensity (mm/hr)	Flow Q (L/s)	Allowable Runoff (L/s)	Net Flow to be Stored (L/s)	Storage Req'd (m <sup>3</sup> )
100 YEAR	10	178.56	32.76	7.6	25.19	15.11
	15	142.89	26.22	7.6	18.65	16.78
	<b>20</b>	<b>119.95</b>	<b>22.01</b>	<b>7.6</b>	<b>14.44</b>	<b>17.33</b>
	25	103.85	19.05	7.6	11.48	17.22
	30	91.87	16.86	7.6	9.29	16.71

Equations:

Flow Equation

$$Q = 2.78 \times C \times I \times A$$

Where:

C is the runoff coefficient

I is the rainfall intensity, City of Ottawa IDF

A is the total drainage area

Runoff Coefficient Equation

$$C_s = (A_{hard} \times 0.9 + A_{soft} \times 0.2) / A_{Tot}$$

$$C_{100} = (A_{hard} \times 1.0 + A_{soft} \times 0.25) / A_{Tot}$$

**Table 1D: Roof Drain Flows**

Roof Drains		
Roof Area	660	m <sup>2</sup>
Qty	4	
Type	Accutrol RD-100-A-ADJ	
Setting	Fully Open	
Design Head	0.05-0.15	m
Design Flow 1" of head	0.32	L/s (ea)
Design Flow 2" of head	0.63	L/s (ea)
Design Flow 3" of head	0.95	L/s (ea)
Design Flow 4" of head	1.26	L/s (ea)
Design Flow 5" of head	1.58	L/s (ea)
Design Flow 6" of head	1.89	L/s (ea)

**Table 1E: Total Roof Storage**

Storm Event	Roof Drain ID	**Avg Area Per Roof Drain (m <sup>2</sup> )	Avg Ponding Depth Per Roof Drain (m)	*Total Volume (m <sup>3</sup> )	Total Volume (m <sup>3</sup> ) Required
5 Year	RD-20	92.6	0.089	4.12	-
	RD-21	133.1	0.089	5.92	-
	RD-22	89.7	0.089	3.99	-
	RD-23	48.9	0.089	2.17	-
<b>Total</b>				<b>16.19</b>	<b>8.62</b>
100 Year	RD-20	92.6	0.152	7.06	-
	RD-21	133.1	0.152	10.14	-
	RD-22	89.7	0.152	6.84	-
	RD-23	48.9	0.152	3.73	-
<b>Total</b>				<b>27.76</b>	<b>17.33</b>

\*Note: Ponding volumes calculated using end area equation:

$$V = \frac{Area \times Depth}{2}$$

**HIGH CASINO ROOF**

**TABLE 1A: Post-Development Runoff Coefficient "C" - R6b Controlled Roof Area**

Area	Surface	Ha	5 Year Event		100 Year Event	
			"C"	C <sub>avg</sub>	"C" + 25%	*C <sub>avg</sub>
Total	Hard	0.000	0.90	0.90	1.00	1.00
0.119	Roof	0.119	0.90			
	Soft	0.000	0.20			

**TABLE 1B: 5 YEAR EVENT QUANTITY STORAGE REQUIREMENT - R6b Controlled Roof Area**

0.119 =Area (ha)  
 0.90 = C

Return Period	Time (min)	Intensity (mm/hr)	Flow Q (L/s)	Allowable Runoff (L/s)	Net Flow to be Stored (L/s)	Storage Req'd (m <sup>3</sup> )
5 YEAR	5	141.18	42.03	11.0	30.99	9.30
	10	104.19	31.02	11.0	19.98	11.99
	<b>15</b>	<b>83.56</b>	<b>24.88</b>	<b>11.0</b>	<b>13.84</b>	<b>12.45</b>
	20	70.25	20.92	11.0	9.88	11.85
	25	60.90	18.13	11.0	7.09	10.64

**TABLE 1C: 100 YEAR EVENT QUANTITY STORAGE REQUIREMENT - R6b Controlled Roof Area**

0.119 =Area (ha)  
 1.00 = C

Return Period	Time (min)	Intensity (mm/hr)	Flow Q (L/s)	Allowable Runoff (L/s)	Net Flow to be Stored (L/s)	Storage Req'd (m <sup>3</sup> )
100 YEAR	5	242.70	80.29	18.9	61.36	18.41
	10	178.56	59.07	18.9	40.14	24.09
	<b>15</b>	<b>142.89</b>	<b>47.27</b>	<b>18.9</b>	<b>28.35</b>	<b>25.51</b>
	20	119.95	39.68	18.9	20.76	24.91
	25	103.85	34.35	18.9	15.43	23.14

Equations:

Flow Equation

$$Q = 2.78 \times C \times I \times A$$

Where:

C is the runoff coefficient

I is the rainfall intensity, City of Ottawa IDF

A is the total drainage area

Runoff Coefficient Equation

$$C_s = (A_{hard} \times 0.9 + A_{soft} \times 0.2) / A_{Tot}$$

$$C_{100} = (A_{hard} \times 1.0 + A_{soft} \times 0.25) / A_{Tot}$$

**Table 1D: Roof Drain Flows**

Roof Drains		
Roof Area	1190	m <sup>2</sup>
Qty	10	
Type	Accutrol RD-100-A-ADJ	
Setting	Fully Open	
Design Head	0.05-0.15	m
Design Flow 1" of head	0.32	L/s (ea)
Design Flow 2" of head	0.63	L/s (ea)
Design Flow 3" of head	0.95	L/s (ea)
Design Flow 4" of head	1.26	L/s (ea)
Design Flow 5" of head	1.58	L/s (ea)
Design Flow 6" of head	1.89	L/s (ea)

**Table 1E: Total Roof Storage**

Storm Event	Roof Drain ID	**Avg Area Per Roof Drain (m <sup>2</sup> )	Avg Ponding Depth Per Roof Drain (m)	*Total Volume (m <sup>3</sup> )	Total Volume (m <sup>3</sup> ) Required
5 Year	RD-24a & 24b	53.4	0.089	2.37	-
	RD-25a & 25b	89.5	0.089	3.98	-
	RD-26a & 26b	91.1	0.089	4.05	-
	RD-27a & 27b	84.5	0.089	3.76	-
	RD-28a & 28b	45.5	0.089	2.02	-
<b>Total</b>				<b>16.18</b>	<b>12.45</b>
100 Year	RD-24a & 24b	53.4	0.152	4.07	-
	RD-25a & 25b	89.5	0.152	6.82	-
	RD-26a & 26b	91.1	0.152	6.94	-
	RD-27a & 27b	84.5	0.152	6.44	-
	RD-28a & 28b	45.5	0.152	3.47	-
<b>Total</b>				<b>27.74</b>	<b>25.51</b>

\*Note: Ponding volumes calculated using end area equation:

$$V = \frac{Area \times Depth}{2}$$

**GAMING PATIO ROOF**

**TABLE 1A: Post-Development Runoff Coefficient "C" - R7 Controlled Roof Area**

Area	Surface	Ha	5 Year Event		100 Year Event	
			"C"	C <sub>avg</sub>	"C" + 25%	*C <sub>avg</sub>
Total	Hard	0.000	0.90	0.90	1.00	1.00
0.061	Roof	0.061	0.90		1.00	
	Soft	0.000	0.20		0.25	

**TABLE 1B: 5 YEAR EVENT QUANTITY STORAGE REQUIREMENT - R7 Controlled Roof Area**

0.0612 =Area (ha)  
 0.90 = C

Return Period	Time (min)	Intensity (mm/hr)	Flow Q (L/s)	Allowable Runoff (L/s)	Net Flow to be Stored (L/s)	Storage Req'd (m <sup>3</sup> )
5 YEAR	15	83.56	12.79	3.3	9.48	8.53
	20	70.25	10.76	3.3	7.44	8.93
	<b>25</b>	<b>60.90</b>	<b>9.32</b>	<b>3.3</b>	<b>6.01</b>	<b>9.02</b>
	30	53.93	8.26	3.3	4.95	8.90
	35	48.52	7.43	3.3	4.12	8.65

**TABLE 1C: 100 YEAR EVENT QUANTITY STORAGE REQUIREMENT - R7 Controlled Roof Area**

0.0612 =Area (ha)  
 1.00 = C

Return Period	Time (min)	Intensity (mm/hr)	Flow Q (L/s)	Allowable Runoff (L/s)	Net Flow to be Stored (L/s)	Storage Req'd (m <sup>3</sup> )
100 YEAR	15	142.89	24.31	5.7	18.63	16.77
	20	119.95	20.41	5.7	14.73	17.68
	<b>25</b>	<b>103.85</b>	<b>17.67</b>	<b>5.7</b>	<b>11.99</b>	<b>17.99</b>
	30	91.87	15.63	5.7	9.95	17.91
	35	82.58	14.05	5.7	8.37	17.58

Equations:

Flow Equation

$$Q = 2.78 \times C \times I \times A$$

Where:

C is the runoff coefficient

I is the rainfall intensity, City of Ottawa IDF

A is the total drainage area

Runoff Coefficient Equation

$$C_s = (A_{\text{hard}} \times 0.9 + A_{\text{soft}} \times 0.2) / A_{\text{Tot}}$$

$$C_{100} = (A_{\text{hard}} \times 1.0 + A_{\text{soft}} \times 0.25) / A_{\text{Tot}}$$

**Table 1D: Roof Drain Flows**

Roof Drains	
Roof Area	612 m <sup>2</sup>
Qty	3
Type	Accutrol RD-100-A-ADJ
Setting	Fully Open
Design Head	0.05-0.15 m
Design Flow 1" of head	0.32 L/s (ea)
Design Flow 2" of head	0.63 L/s (ea)
Design Flow 3" of head	0.95 L/s (ea)
Design Flow 4" of head	1.26 L/s (ea)
Design Flow 5" of head	1.58 L/s (ea)
Design Flow 6" of head	1.89 L/s (ea)

**Table 1E: Total Roof Storage**

Storm Event	Roof Drain ID	**Avg Area Per Roof Drain (m <sup>2</sup> )	Avg Ponding Depth Per Roof Drain (m)	*Total Volume (m <sup>3</sup> )	Total Volume (m <sup>3</sup> ) Required
5 Year	RD-29	204.0	0.089	6.05	-
	RD-30	204.0	0.089	6.05	-
	RD-31	204.0	0.089	6.05	-
<b>Total</b>				<b>18.14</b>	<b>9.02</b>
100 Year	RD-29	204.0	0.152	10.36	-
	RD-30	204.0	0.152	10.36	-
	RD-31	204.0	0.152	10.36	-
<b>Total</b>				<b>31.09</b>	<b>17.99</b>

\*Note: Ponding volumes calculated using cone equation:

$$V = \frac{\text{Area} \times \text{Depth}}{3}$$

**EAST ENTRANCE ROOF**

**TABLE 1A: Post-Development Runoff Coefficient "C" - R8 Controlled Roof Area**

Area	Surface	Ha	5 Year Event		100 Year Event	
			"C"	C <sub>avg</sub>	"C" + 25%	*C <sub>avg</sub>
Total	Hard	0.000	0.90	0.90	1.00	1.00
0.009	Roof	0.009	0.90		1.00	
	Soft	0.000	0.20		0.25	

**TABLE 1B: 5 YEAR EVENT QUANTITY STORAGE REQUIREMENT - R8 Controlled Roof Area**

0.009 =Area (ha)  
 0.90 = C

Return Period	Time (min)	Intensity (mm/hr)	Flow Q (L/s)	Allowable Runoff (L/s)	Net Flow to be Stored (L/s)	Storage Req'd (m <sup>3</sup> )
5 YEAR	0	230.48	5.19	1.1	4.09	0.00
	5	141.18	3.18	1.1	2.07	0.62
	<b>10</b>	<b>104.19</b>	<b>2.35</b>	<b>1.1</b>	<b>1.24</b>	<b>0.75</b>
	15	83.56	1.88	1.1	0.78	0.70
	20	70.25	1.58	1.1	0.48	0.57

**TABLE 1C: 100 YEAR EVENT QUANTITY STORAGE REQUIREMENT - R8 Controlled Roof Area**

0.009 =Area (ha)  
 1.00 = C

Return Period	Time (min)	Intensity (mm/hr)	Flow Q (L/s)	Allowable Runoff (L/s)	Net Flow to be Stored (L/s)	Storage Req'd (m <sup>3</sup> )
100 YEAR	0	398.62	9.97	1.9	8.08	0.00
	5	242.70	6.07	1.9	4.18	1.25
	<b>10</b>	<b>178.56</b>	<b>4.47</b>	<b>1.9</b>	<b>2.57</b>	<b>1.54</b>
	15	142.89	3.58	1.9	1.68	1.51
	20	119.95	3.00	1.9	1.11	1.33

Equations:

Flow Equation

$$Q = 2.78 \times C \times I \times A$$

Where:

C is the runoff coefficient

I is the rainfall intensity, City of Ottawa IDF

A is the total drainage area

Runoff Coefficient Equation

$$C_s = (A_{\text{hard}} \times 0.9 + A_{\text{soft}} \times 0.2) / A_{\text{Tot}}$$

$$C_{100} = (A_{\text{hard}} \times 1.0 + A_{\text{soft}} \times 0.25) / A_{\text{Tot}}$$

**Table 1D: Roof Drain Flows**

Roof Drains	
Roof Area	90 m <sup>2</sup>
Qty	1
Type	Accutrol RD-100-A-ADJ
Setting	Fully Open
Design Head	0.05-0.15 m
Design Flow 1" of head	0.32 L/s (ea)
Design Flow 2" of head	0.63 L/s (ea)
Design Flow 3" of head	0.95 L/s (ea)
Design Flow 4" of head	1.26 L/s (ea)
Design Flow 5" of head	1.58 L/s (ea)
Design Flow 6" of head	1.89 L/s (ea)

**Table 1E: Total Roof Storage**

Storm Event	Roof Drain ID	**Avg Area Per Roof Drain (m <sup>2</sup> )	Avg Ponding Depth Per Roof Drain (m)	*Total Volume (m <sup>3</sup> )	Total Volume (m <sup>3</sup> ) Required
5 Year	RD-32	85.5	0.089	2.53	0.75
<b>Total</b>				<b>2.53</b>	<b>0.75</b>
100 Year	RD-32	85.5	0.152	4.34	1.54
<b>Total</b>				<b>4.34</b>	<b>1.54</b>

\*Note: Ponding volumes calculated using cone equation:

$$V = \frac{\text{Area} \times \text{Depth}}{3}$$

**LOWER CASINO ROOF**

**TABLE 1A: Post-Development Runoff Coefficient "C" - R9 Controlled Roof Area**

Area	Surface	Ha	5 Year Event		100 Year Event	
			"C"	C <sub>avg</sub>	"C" + 25%	*C <sub>avg</sub>
Total	Hard	0.000	0.90	0.90	1.00	1.00
0.062	Roof	0.062	0.90		1.00	
	Soft	0.000	0.20		0.25	

**TABLE 1B: 5 YEAR EVENT QUANTITY STORAGE REQUIREMENT - R9 Controlled Roof Area**

0.0619 =Area (ha)  
 0.90 = C

Return Period	Time (min)	Intensity (mm/hr)	Flow Q (L/s)	Allowable Runoff (L/s)	Net Flow to be Stored (L/s)	Storage Req'd (m <sup>3</sup> )
5 YEAR	25	60.90	9.43	2.2	7.22	10.83
	30	53.93	8.35	2.2	6.14	11.06
	<b>35</b>	<b>48.52</b>	<b>7.51</b>	<b>2.2</b>	<b>5.31</b>	<b>11.14</b>
	40	44.18	6.84	2.2	4.63	11.12
	45	40.63	6.29	2.2	4.08	11.03

**TABLE 1C: 100 YEAR EVENT QUANTITY STORAGE REQUIREMENT - R9 Controlled Roof Area**

0.0619 =Area (ha)  
 1.00 = C

Return Period	Time (min)	Intensity (mm/hr)	Flow Q (L/s)	Allowable Runoff (L/s)	Net Flow to be Stored (L/s)	Storage Req'd (m <sup>3</sup> )
100 YEAR	30	91.87	15.81	3.8	12.02	21.64
	35	82.58	14.21	3.8	10.42	21.89
	<b>40</b>	<b>75.15</b>	<b>12.93</b>	<b>3.8</b>	<b>9.15</b>	<b>21.95</b>
	45	69.05	11.88	3.8	8.10	21.86
	50	63.95	11.01	3.8	7.22	21.66

Equations:

Flow Equation

$$Q = 2.78 \times C \times I \times A$$

Where:

C is the runoff coefficient

I is the rainfall intensity, City of Ottawa IDF

A is the total drainage area

Runoff Coefficient Equation

$$C_s = (A_{hard} \times 0.9 + A_{soft} \times 0.2) / A_{Tot}$$

$$C_{100} = (A_{hard} \times 1.0 + A_{soft} \times 0.25) / A_{Tot}$$

**Table 1D: Roof Drain Flows**

Roof Drains		
Roof Area	619	m <sup>2</sup>
Qty	2	
Type	Accutrol RD-100-A-ADJ	
Setting	Fully Open	
Design Head	0.05-0.15	m
Design Flow 1" of head	0.32	L/s (ea)
Design Flow 2" of head	0.63	L/s (ea)
Design Flow 3" of head	0.95	L/s (ea)
Design Flow 4" of head	1.26	L/s (ea)
Design Flow 5" of head	1.58	L/s (ea)
Design Flow 6" of head	1.89	L/s (ea)

**Table 1E: Total Roof Storage**

Storm Event	Roof Drain ID	**Avg Area Per Roof Drain (m <sup>2</sup> )	Avg Ponding Depth Per Roof Drain (m)	*Total Volume (m <sup>3</sup> )	Total Volume (m <sup>3</sup> ) Required
5 Year	RD-33a & 33b	566.1	0.089	16.78	11.14
<b>Total</b>				<b>16.78</b>	<b>11.14</b>
100 Year	RD-33a & 33b	566.1	0.152	28.76	21.95
<b>Total</b>				<b>28.76</b>	<b>21.95</b>

\*Note: Ponding volumes calculated using cone equation:

$$V = \frac{Area \times Depth}{3}$$



**LOWER CASINO ROOF**

**TABLE 1A: Post-Development Runoff Coefficient "C" - R10 Controlled Roof Area**

Area	Surface	Ha	5 Year Event		100 Year Event	
			"C"	C <sub>avg</sub>	"C" + 25%	*C <sub>avg</sub>
Total	Hard	0.000	0.90	0.90	1.00	1.00
0.094	Roof	0.094	0.90		1.00	
	Soft	0.000	0.20		0.25	

**TABLE 1B: 5 YEAR EVENT QUANTITY STORAGE REQUIREMENT - R10 Controlled Roof Area**

0.0935 =Area (ha)  
 0.90 = C

Return Period	Time (min)	Intensity (mm/hr)	Flow Q (L/s)	Allowable Runoff (L/s)	Net Flow to be Stored (L/s)	Storage Req'd (m <sup>3</sup> )
5 YEAR	20	70.25	16.43	4.4	12.02	14.42
	25	60.90	14.25	4.4	9.83	14.74
	<b>30</b>	<b>53.93</b>	<b>12.62</b>	<b>4.4</b>	<b>8.20</b>	<b>14.76</b>
	35	48.52	11.35	4.4	6.93	14.56
	40	44.18	10.34	4.4	5.92	14.21

**TABLE 1C: 100 YEAR EVENT QUANTITY STORAGE REQUIREMENT - R10 Controlled Roof Area**

0.0935 =Area (ha)  
 1.00 = C

Return Period	Time (min)	Intensity (mm/hr)	Flow Q (L/s)	Allowable Runoff (L/s)	Net Flow to be Stored (L/s)	Storage Req'd (m <sup>3</sup> )
100 YEAR	20	119.95	31.18	7.6	23.61	28.33
	25	103.85	26.99	7.6	19.42	29.13
	<b>30</b>	<b>91.87</b>	<b>23.88</b>	<b>7.6</b>	<b>16.31</b>	<b>29.36</b>
	35	82.58	21.46	7.6	13.89	29.18
	40	75.15	19.53	7.6	11.96	28.71

Equations:

Flow Equation

$$Q = 2.78 \times C \times I \times A$$

Where:

C is the runoff coefficient

I is the rainfall intensity, City of Ottawa IDF

A is the total drainage area

Runoff Coefficient Equation

$$C_s = (A_{\text{hard}} \times 0.9 + A_{\text{soft}} \times 0.2) / A_{\text{Tot}}$$

$$C_{100} = (A_{\text{hard}} \times 1.0 + A_{\text{soft}} \times 0.25) / A_{\text{Tot}}$$

**Table 1D: Roof Drain Flows**

Roof Drains		
Roof Area	935	m <sup>2</sup>
Qty	4	
Type	Accutrol RD-100-A-ADJ	
Setting	Fully Open	
Design Head	0.05-0.15	m
Design Flow 1" of head	0.32	L/s (ea)
Design Flow 2" of head	0.63	L/s (ea)
Design Flow 3" of head	0.95	L/s (ea)
Design Flow 4" of head	1.26	L/s (ea)
Design Flow 5" of head	1.58	L/s (ea)
Design Flow 6" of head	1.89	L/s (ea)

**Table 1E: Total Roof Storage**

Storm Event	Roof Drain ID	**Avg Area Per Roof Drain (m <sup>2</sup> )	Avg Ponding Depth Per Roof Drain (m)	*Total Volume (m <sup>3</sup> )	Total Volume (m <sup>3</sup> ) Required
5 Year	RD-34	285.0	0.089	8.45	-
	RD-35	253.0	0.089	7.50	-
	RD-36	204.6	0.089	6.06	-
	RD-37	178.6	0.089	5.29	-
<b>Total</b>				<b>27.30</b>	<b>14.76</b>
100 Year	RD-34	285.0	0.152	14.48	-
	RD-35	253.0	0.152	12.85	-
	RD-36	204.6	0.152	10.39	-
	RD-37	178.6	0.152	9.07	-
<b>Total</b>				<b>46.80</b>	<b>29.36</b>

\*Note: Ponding volumes calculated using cone equation:

$$V = \frac{\text{Area} \times \text{Depth}}{3}$$

**LIVE LOADING DOCK ROOF**

**TABLE 1A: Post-Development Runoff Coefficient "C" - R11 Controlled Roof Area**

Area	Surface	Ha	5 Year Event		100 Year Event	
			"C"	C <sub>avg</sub>	"C" + 25%	*C <sub>avg</sub>
Total	Hard	0.000	0.90	0.90	1.00	1.00
0.064	Roof	0.064	0.90		1.00	
	Soft	0.000	0.20		0.25	

**TABLE 1B: 5 YEAR EVENT QUANTITY STORAGE REQUIREMENT - R11 Controlled Roof Area**

0.064 =Area (ha)  
 0.90 = C

Return Period	Time (min)	Intensity (mm/hr)	Flow Q (L/s)	Allowable Runoff (L/s)	Net Flow to be Stored (L/s)	Storage Req'd (m <sup>3</sup> )
5 YEAR	10	104.19	16.68	4.4	12.27	7.36
	15	83.56	13.38	4.4	8.96	8.07
	<b>20</b>	<b>70.25</b>	<b>11.25</b>	<b>4.4</b>	<b>6.83</b>	<b>8.20</b>
	25	60.90	9.75	4.4	5.33	8.00
	30	53.93	8.64	4.4	4.22	7.59

**TABLE 1C: 100 YEAR EVENT QUANTITY STORAGE REQUIREMENT - R11 Controlled Roof Area**

0.064 =Area (ha)  
 1.00 = C

Return Period	Time (min)	Intensity (mm/hr)	Flow Q (L/s)	Allowable Runoff (L/s)	Net Flow to be Stored (L/s)	Storage Req'd (m <sup>3</sup> )
100 YEAR	10	178.56	31.77	7.6	24.20	14.52
	15	142.89	25.42	7.6	17.85	16.07
	<b>20</b>	<b>119.95</b>	<b>21.34</b>	<b>7.6</b>	<b>13.77</b>	<b>16.52</b>
	25	103.85	18.48	7.6	10.91	16.36
	30	91.87	16.35	7.6	8.77	15.79

Equations:

Flow Equation

$$Q = 2.78 \times C \times I \times A$$

Where:

C is the runoff coefficient

I is the rainfall intensity, City of Ottawa IDF

A is the total drainage area

Runoff Coefficient Equation

$$C_s = (A_{hard} \times 0.9 + A_{soft} \times 0.2) / A_{Tot}$$

$$C_{100} = (A_{hard} \times 1.0 + A_{soft} \times 0.25) / A_{Tot}$$

**Table 1D: Roof Drain Flows**

Roof Drains		
Roof Area	640	m <sup>2</sup>
Qty	4	
Type	Accutrol RD-100-A-ADJ	
Setting	Fully Open	
Design Head	0.05-0.15	m
Design Flow 1" of head	0.32	L/s (ea)
Design Flow 2" of head	0.63	L/s (ea)
Design Flow 3" of head	0.95	L/s (ea)
Design Flow 4" of head	1.26	L/s (ea)
Design Flow 5" of head	1.58	L/s (ea)
Design Flow 6" of head	1.89	L/s (ea)

**Table 1E: Total Roof Storage**

Storm Event	Roof Drain ID	**Avg Area Per Roof Drain (m <sup>2</sup> )	Avg Ponding Depth Per Roof Drain (m)	*Total Volume (m <sup>3</sup> )	Total Volume (m <sup>3</sup> ) Required
5 Year	RD-38	129.4	0.089	3.83	-
	RD-39	282.3	0.089	8.37	-
	RD-40	69.9	0.089	2.07	-
	RD-41	141.0	0.089	4.18	-
<b>Total</b>				<b>18.45</b>	<b>8.20</b>
100 Year	RD-38	129.4	0.152	6.57	-
	RD-39	282.3	0.152	14.34	-
	RD-40	69.9	0.152	3.55	-
	RD-41	141.0	0.152	7.16	-
<b>Total</b>				<b>31.63</b>	<b>16.52</b>

\*Note: Ponding volumes calculated using cone equation:

$$V = \frac{Area \times Depth}{3}$$

**LIVE AUDITORIUM ROOF**

**TABLE 1A: Post-Development Runoff Coefficient "C" - R12a Controlled Roof Area**

Area	Surface	Ha	5 Year Event		100 Year Event	
			"C"	C <sub>avg</sub>	"C" + 25%	*C <sub>avg</sub>
Total	Hard	0.000	0.90	0.90	1.00	1.00
0.119	Roof	0.119	0.90		1.00	
	Soft	0.000	0.20		0.25	

**TABLE 1B: 5 YEAR EVENT QUANTITY STORAGE REQUIREMENT - R12a Controlled Roof Area**

0.119 =Area (ha)  
 0.90 = C

Return Period	Time (min)	Intensity (mm/hr)	Flow Q (L/s)	Allowable Runoff (L/s)	Net Flow to be Stored (L/s)	Storage Req'd (m <sup>3</sup> )
5 YEAR	15	83.56	24.88	6.6	18.25	16.43
	20	70.25	20.92	6.6	14.29	17.15
	<b>25</b>	<b>60.90</b>	<b>18.13</b>	<b>6.6</b>	<b>11.51</b>	<b>17.26</b>
	30	53.93	16.06	6.6	9.43	16.98
	35	48.52	14.45	6.6	7.82	16.42

**TABLE 1C: 100 YEAR EVENT QUANTITY STORAGE REQUIREMENT - R12a Controlled Roof Area**

0.119 =Area (ha)  
 1.00 = C

Return Period	Time (min)	Intensity (mm/hr)	Flow Q (L/s)	Allowable Runoff (L/s)	Net Flow to be Stored (L/s)	Storage Req'd (m <sup>3</sup> )
100 YEAR	15	142.89	47.27	11.4	35.92	32.32
	20	119.95	39.68	11.4	28.33	33.99
	<b>25</b>	<b>103.85</b>	<b>34.35</b>	<b>11.4</b>	<b>23.00</b>	<b>34.50</b>
	30	91.87	30.39	11.4	19.04	34.26
	35	82.58	27.32	11.4	15.96	33.52

Equations:

Flow Equation

$$Q = 2.78 \times C \times I \times A$$

Where:

C is the runoff coefficient

I is the rainfall intensity, City of Ottawa IDF

A is the total drainage area

Runoff Coefficient Equation

$$C_5 = (A_{\text{hard}} \times 0.9 + A_{\text{soft}} \times 0.2) / A_{\text{Tot}}$$

$$C_{100} = (A_{\text{hard}} \times 1.0 + A_{\text{soft}} \times 0.25) / A_{\text{Tot}}$$

**Table 1D: Roof Drain Flows**

Roof Drains		
Roof Area	1190	m <sup>2</sup>
Qty	6	
Type	Accutrol RD-100-A-ADJ	
Setting	Fully Open	
Design Head	0.05-0.15	m
Design Flow 1" of head	0.32	L/s (ea)
Design Flow 2" of head	0.63	L/s (ea)
Design Flow 3" of head	0.95	L/s (ea)
Design Flow 4" of head	1.26	L/s (ea)
Design Flow 5" of head	1.58	L/s (ea)
Design Flow 6" of head	1.89	L/s (ea)

**Table 1E: Total Roof Storage**

Storm Event	Roof Drain ID	**Avg Area Per Roof Drain (m <sup>2</sup> )	Avg Ponding Depth Per Roof Drain (m)	*Total Volume (m <sup>3</sup> )	Total Volume (m <sup>3</sup> ) Required
5 Year	RD-42a & 42b	144.6	0.089	6.43	-
	RD-43a & 43b	179.4	0.089	7.97	-
	RD-44a & 44b	162.9	0.089	7.24	-
<b>Total</b>				<b>21.64</b>	<b>17.26</b>
100 Year	RD-42a & 42b	144.6	0.152	11.02	-
	RD-43a & 43b	179.4	0.152	13.67	-
	RD-44a & 44b	162.9	0.152	12.41	-
<b>Total</b>				<b>37.10</b>	<b>34.50</b>

\*Note: Ponding volumes calculated using end area equation:

$$V = \frac{\text{Area} \times \text{Depth}}{2}$$

**LIVE AUDITORIUM ROOF**

**TABLE 1A: Post-Development Runoff Coefficient "C" - R12b Controlled Roof Area**

Area	Surface	Ha	5 Year Event		100 Year Event	
			"C"	C <sub>avg</sub>	"C" + 25%	*C <sub>avg</sub>
Total	Hard	0.000	0.90	0.90	1.00	1.00
0.120	Roof	0.120	0.90		1.00	
	Soft	0.000	0.20		0.25	

**TABLE 1B: 5 YEAR EVENT QUANTITY STORAGE REQUIREMENT - R12b Controlled Roof Area**

0.12 =Area (ha)  
 0.90 = C

Return Period	Time (min)	Intensity (mm/hr)	Flow Q (L/s)	Allowable Runoff (L/s)	Net Flow to be Stored (L/s)	Storage Req'd (m <sup>3</sup> )
5 YEAR	15	83.56	25.09	6.6	18.46	16.62
	20	70.25	21.09	6.6	14.47	17.36
	<b>25</b>	<b>60.90</b>	<b>18.28</b>	<b>6.6</b>	<b>11.66</b>	<b>17.49</b>
	30	53.93	16.19	6.6	9.57	17.22
	35	48.52	14.57	6.6	7.94	16.68

**TABLE 1C: 100 YEAR EVENT QUANTITY STORAGE REQUIREMENT - R12b Controlled Roof Area**

0.12 =Area (ha)  
 1.00 = C

Return Period	Time (min)	Intensity (mm/hr)	Flow Q (L/s)	Allowable Runoff (L/s)	Net Flow to be Stored (L/s)	Storage Req'd (m <sup>3</sup> )
100 YEAR	15	142.89	47.67	11.4	36.31	32.68
	20	119.95	40.02	11.4	28.66	34.39
	<b>25</b>	<b>103.85</b>	<b>34.64</b>	<b>11.4</b>	<b>23.29</b>	<b>34.93</b>
	30	91.87	30.65	11.4	19.29	34.72
	35	82.58	27.55	11.4	16.19	34.00

Equations:

Flow Equation

$$Q = 2.78 \times C \times I \times A$$

Where:

C is the runoff coefficient

I is the rainfall intensity, City of Ottawa IDF

A is the total drainage area

Runoff Coefficient Equation

$$C_5 = (A_{\text{hard}} \times 0.9 + A_{\text{soft}} \times 0.2) / A_{\text{Tot}}$$

$$C_{100} = (A_{\text{hard}} \times 1.0 + A_{\text{soft}} \times 0.25) / A_{\text{Tot}}$$

**Table 1D: Roof Drain Flows**

Roof Drains		
Roof Area	1200	m <sup>2</sup>
Qty	6	
Type	Accutrol RD-100-A-ADJ	
Setting	Fully Open	
Design Head	0.05-0.15	m
Design Flow 1" of head	0.32	L/s (ea)
Design Flow 2" of head	0.63	L/s (ea)
Design Flow 3" of head	0.95	L/s (ea)
Design Flow 4" of head	1.26	L/s (ea)
Design Flow 5" of head	1.58	L/s (ea)
Design Flow 6" of head	1.89	L/s (ea)

**Table 1E: Total Roof Storage**

Storm Event	Roof Drain ID	**Avg Area Per Roof Drain (m <sup>2</sup> )	Avg Ponding Depth Per Roof Drain (m)	*Total Volume (m <sup>3</sup> )	Total Volume (m <sup>3</sup> ) Required
5 Year	RD-45a & 445b	144.7	0.089	6.43	-
	RD-46a & 46b	179.3	0.089	7.97	-
	RD-47a & 47b	162.9	0.089	7.24	-
<b>Total</b>				<b>21.64</b>	<b>17.49</b>
100 Year	RD-45a & 445b	144.7	0.152	11.03	-
	RD-46a & 46b	179.3	0.152	13.66	-
	RD-47a & 47b	162.9	0.152	12.41	-
<b>Total</b>				<b>37.10</b>	<b>34.93</b>

\*Note: Ponding volumes calculated using end area equation:

$$V = \frac{\text{Area} \times \text{Depth}}{2}$$

**LIVE AUDITORIUM LOADING ROOF**

**TABLE 1A: Post-Development Runoff Coefficient "C" - R13 Controlled Roof Area**

Area	Surface	Ha	5 Year Event		100 Year Event	
			"C"	C <sub>avg</sub>	"C" + 25%	*C <sub>avg</sub>
Total	Hard	0.000	0.90	0.90	1.00	1.00
0.022	Roof	0.022	0.90		1.00	
	Soft	0.000	0.20		0.25	

**TABLE 1B: 5 YEAR EVENT QUANTITY STORAGE REQUIREMENT - R13 Controlled Roof Area**

0.022 =Area (ha)  
 0.90 = C

Return Period	Time (min)	Intensity (mm/hr)	Flow Q (L/s)	Allowable Runoff (L/s)	Net Flow to be Stored (L/s)	Storage Req'd (m <sup>3</sup> )
5 YEAR	15	83.56	4.60	1.1	3.50	3.15
	20	70.25	3.87	1.1	2.76	3.32
	<b>25</b>	<b>60.90</b>	<b>3.35</b>	<b>1.1</b>	<b>2.25</b>	<b>3.37</b>
	30	53.93	2.97	1.1	1.86	3.36
	35	48.52	2.67	1.1	1.57	3.29

**TABLE 1C: 100 YEAR EVENT QUANTITY STORAGE REQUIREMENT - R13 Controlled Roof Area**

0.022 =Area (ha)  
 1.00 = C

Return Period	Time (min)	Intensity (mm/hr)	Flow Q (L/s)	Allowable Runoff (L/s)	Net Flow to be Stored (L/s)	Storage Req'd (m <sup>3</sup> )
100 YEAR	20	119.95	7.34	1.9	5.44	6.53
	25	103.85	6.35	1.9	4.46	6.69
	<b>30</b>	<b>91.87</b>	<b>5.62</b>	<b>1.9</b>	<b>3.73</b>	<b>6.71</b>
	35	82.58	5.05	1.9	3.16	6.63
	40	75.15	4.60	1.9	2.70	6.49

Equations:

Flow Equation

$$Q = 2.78 \times C \times I \times A$$

Where:

C is the runoff coefficient

I is the rainfall intensity, City of Ottawa IDF

A is the total drainage area

Runoff Coefficient Equation

$$C_s = (A_{\text{hard}} \times 0.9 + A_{\text{soft}} \times 0.2) / A_{\text{Tot}}$$

$$C_{100} = (A_{\text{hard}} \times 1.0 + A_{\text{soft}} \times 0.25) / A_{\text{Tot}}$$

**Table 1D: Roof Drain Flows**

Roof Drains		
Roof Area	220	m <sup>2</sup>
Qty	1	
Type	Accutrol RD-100-A-ADJ	
Setting	Fully Open	
Design Head	0.05-0.15	m
Design Flow 1" of head	0.32	L/s (ea)
Design Flow 2" of head	0.63	L/s (ea)
Design Flow 3" of head	0.95	L/s (ea)
Design Flow 4" of head	1.26	L/s (ea)
Design Flow 5" of head	1.58	L/s (ea)
Design Flow 6" of head	1.89	L/s (ea)

**Table 1E: Total Roof Storage**

Storm Event	Roof Drain ID	**Avg Area Per Roof Drain (m <sup>2</sup> )	Avg Ponding Depth Per Roof Drain (m)	*Total Volume (m <sup>3</sup> )	Total Volume (m <sup>3</sup> ) Required
5 Year	RD-48	210.5	0.089	6.24	3.37
<b>Total</b>				<b>6.24</b>	<b>3.37</b>
100 Year	RD-48	210.5	0.152	10.69	6.71
<b>Total</b>				<b>10.69</b>	<b>6.71</b>

\*Note: Ponding volumes calculated using cone equation:

$$V = \frac{\text{Area} \times \text{Depth}}{3}$$

**LOWER LIVE AUDITORIUM ROOF**

**TABLE 1A: Post-Development Runoff Coefficient "C" - R14 Controlled Roof Area**

Area	Surface	Ha	5 Year Event		100 Year Event	
			"C"	C <sub>avg</sub>	"C" + 25%	*C <sub>avg</sub>
Total	Hard	0.000	0.90	0.90	1.00	1.00
0.013	Roof	0.013	0.90		1.00	
	Soft	0.000	0.20		0.25	

**TABLE 1B: 5 YEAR EVENT QUANTITY STORAGE REQUIREMENT - R14 Controlled Roof Area**

0.0127 =Area (ha)  
 0.90 = C

Return Period	Time (min)	Intensity (mm/hr)	Flow Q (L/s)	Allowable Runoff (L/s)	Net Flow to be Stored (L/s)	Storage Req'd (m <sup>3</sup> )
5 YEAR	5	141.18	4.49	1.1	3.38	1.01
	10	104.19	3.31	1.1	2.21	1.32
	<b>15</b>	<b>83.56</b>	<b>2.66</b>	<b>1.1</b>	<b>1.55</b>	<b>1.40</b>
	20	70.25	2.23	1.1	1.13	1.35
	25	60.90	1.93	1.1	0.83	1.25

**TABLE 1C: 100 YEAR EVENT QUANTITY STORAGE REQUIREMENT - R14 Controlled Roof Area**

0.0127 =Area (ha)  
 1.00 = C

Return Period	Time (min)	Intensity (mm/hr)	Flow Q (L/s)	Allowable Runoff (L/s)	Net Flow to be Stored (L/s)	Storage Req'd (m <sup>3</sup> )
100 YEAR	5	242.70	8.57	1.9	6.68	2.00
	10	178.56	6.30	1.9	4.41	2.65
	<b>15</b>	<b>142.89</b>	<b>5.05</b>	<b>1.9</b>	<b>3.15</b>	<b>2.84</b>
	20	119.95	4.23	1.9	2.34	2.81
	25	103.85	3.67	1.9	1.77	2.66

Equations:

Flow Equation

$$Q = 2.78 \times C \times I \times A$$

Where:

C is the runoff coefficient

I is the rainfall intensity, City of Ottawa IDF

A is the total drainage area

Runoff Coefficient Equation

$$C_s = (A_{\text{hard}} \times 0.9 + A_{\text{soft}} \times 0.2) / A_{\text{Tot}}$$

$$C_{100} = (A_{\text{hard}} \times 1.0 + A_{\text{soft}} \times 0.25) / A_{\text{Tot}}$$

**Table 1D: Roof Drain Flows**

Roof Drains		
Roof Area	127	m <sup>2</sup>
Qty	1	
Type	Accutrol RD-100-A-ADJ	
Setting	Fully Open	
Design Head	0.05-0.15	m
Design Flow 1" of head	0.32	L/s (ea)
Design Flow 2" of head	0.63	L/s (ea)
Design Flow 3" of head	0.95	L/s (ea)
Design Flow 4" of head	1.26	L/s (ea)
Design Flow 5" of head	1.58	L/s (ea)
Design Flow 6" of head	1.89	L/s (ea)

**Table 1E: Total Roof Storage**

Storm Event	Roof Drain ID	**Avg Area Per Roof Drain (m <sup>2</sup> )	Avg Ponding Depth Per Roof Drain (m)	*Total Volume (m <sup>3</sup> )	Total Volume (m <sup>3</sup> ) Required
5 Year	RD-49	107.0	0.089	3.17	1.40
<b>Total</b>				<b>3.17</b>	<b>1.40</b>
100 Year	RD-49	107.0	0.152	5.44	2.84
<b>Total</b>				<b>5.44</b>	<b>2.84</b>

\*Note: Ponding volumes calculated using cone equation:

$$V = \frac{\text{Area} \times \text{Depth}}{3}$$

**Table 8: Post-Development Stormwater Management Summary (Roof Only)**

Area ID	Area (ha)	1:5 Year Weighted Cw	1:100 Year Weighted Cw	Outlet Location	5 Year Storm Event				100 Year Storm Event			
					Release (L/s)	Ponding Depth (m)	Required Volumes (cu.m)	Volume Provided (cu.m.)	Release (L/s)	Ponding Depth (m)	Required Volume (cu.m)	Volume Provided (cu.m.)
R1	0.088	0.90	1.00	BLDG Service	3.3	0.089	15.5	26.1	5.7	0.152	30.5	44.7
R2	0.220	0.90	1.00	BLDG Service	7.7	0.089	39.9	63.5	13.2	0.152	78.5	108.8
R3	0.175	0.90	1.00	BLDG Service	4.4	0.089	36.2	49.2	7.6	0.152	70.7	84.4
R4	0.026	0.90	1.00	BLDG Service	2.2	0.089	2.9	7.3	3.8	0.152	5.9	12.5
R5	0.127	0.90	1.00	BLDG Service	3.3	0.089	26.0	35.8	5.7	0.152	50.7	61.4
R6a	0.066	0.90	1.00	BLDG Service	4.4	0.089	8.6	16.2	7.6	0.152	17.3	27.8
R6b	0.119	0.90	1.00	BLDG Service	11.0	0.089	12.5	16.2	18.9	0.152	25.5	27.7
R7	0.061	0.90	1.00	BLDG Service	3.3	0.089	9.0	18.1	5.7	0.152	18.0	31.1
R8	0.009	0.90	1.00	BLDG Service	1.1	0.089	0.7	2.5	1.9	0.152	1.5	4.3
R10	0.094	0.90	1.00	BLDG Service	4.4	0.089	14.8	27.3	7.6	0.152	29.4	46.8
<b>North Storm Service</b>					<b>45.3</b>		<b>166.0</b>	<b>262.2</b>	<b>77.6</b>		<b>328.1</b>	<b>449.5</b>
	0.985											
R9	0.062	0.90	1.00	Front Service	2.2	0.089	11.1	16.8	3.8	0.152	21.9	28.8
R11	0.064	0.90	1.00	Front Service	4.4	0.089	8.2	18.4	7.6	0.152	16.5	31.6
R12a	0.119	0.90	1.00	Front Service	6.6	0.089	17.3	21.6	11.4	0.152	34.5	37.1
R12b	0.120	0.90	1.00	Front Service	6.6	0.089	17.5	21.6	11.4	0.152	34.9	37.1
R13	0.022	0.90	1.00	Front Service	1.1	0.089	3.4	6.2	1.9	0.152	6.7	10.7
R14	0.013	0.90	1.00	Front Service	1.1	0.089	1.4	3.2	1.9	0.152	2.8	5.4
<b>South Storm Service</b>					<b>22.1</b>		<b>58.9</b>	<b>87.9</b>	<b>37.9</b>		<b>117.4</b>	<b>150.7</b>
<b>Total</b>					<b>67.4</b>		<b>224.9</b>	<b>350.1</b>	<b>115.5</b>		<b>445.5</b>	<b>600.2</b>

# StormTech SC-740 Chamber

Designed to meet the most stringent industry performance standards for superior structural integrity while providing designers with a cost-effective method to save valuable land and protect water resources. The StormTech system is designed primarily to be used under parking lots, thus maximizing land usage for private (commercial) and public applications. StormTech chambers can also be used in conjunction with Green Infrastructure, thus enhancing the performance and extending the service life of these practices.

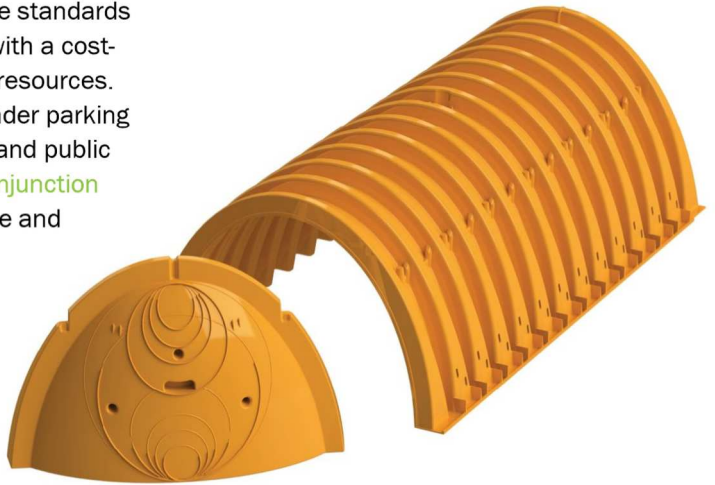

## StormTech SC-740 Chamber (not to scale)

### Nominal Chamber Specifications

Size (L x W x H)	85.4" x 51.0" x 30.0" (2,170 x 1,295 x 762 mm)
Chamber Storage	45.9 ft <sup>3</sup> (1.30 m <sup>3</sup> )
Min. Installed Storage*	74.9 ft <sup>3</sup> (2.12 m <sup>3</sup> )
Weight	74.0 lbs (33.6 kg)

\*Assumes 6" (150 mm) stone above, below and between chambers and 40% stone porosity.

### Shipping

30 chambers/pallet

60 end caps/pallet

12 pallets/truck

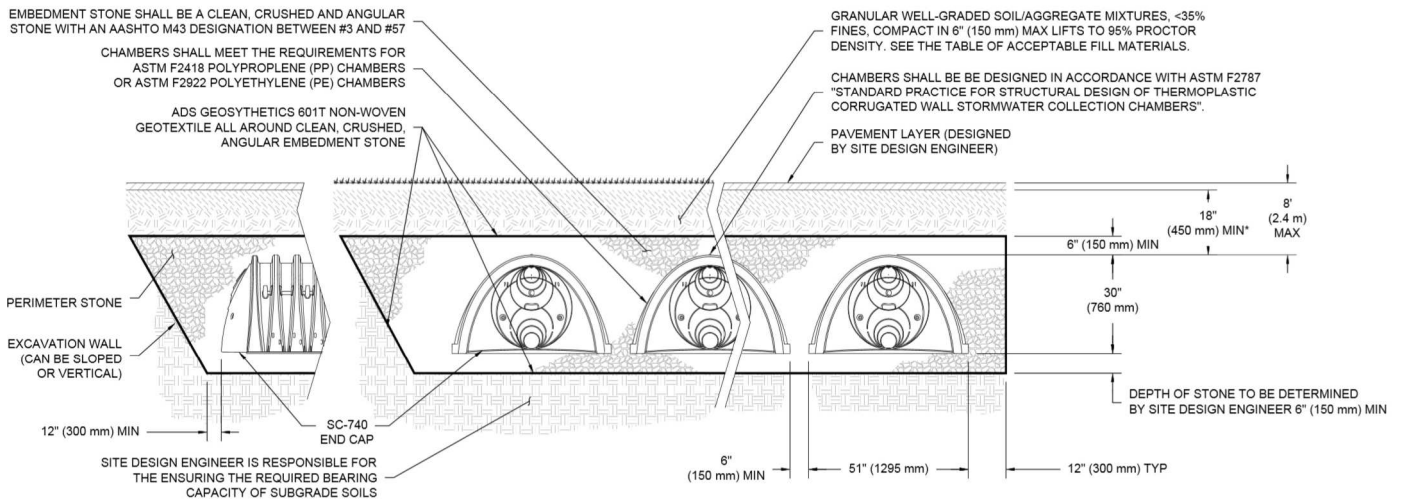
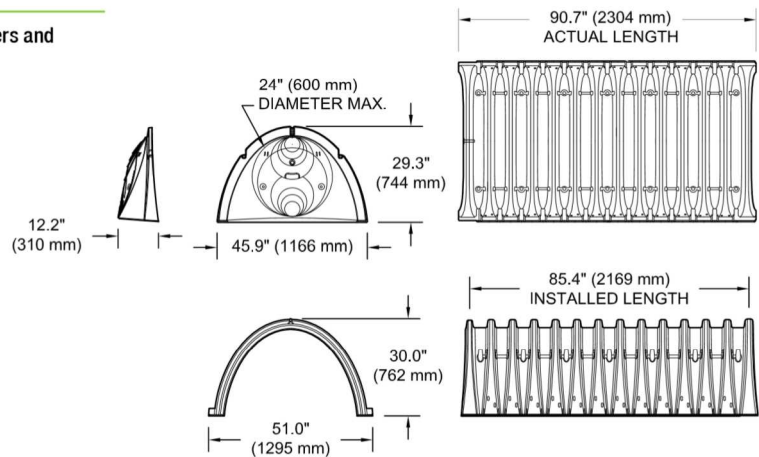

\*MINIMUM COVER TO BOTTOM OF FLEXIBLE PAVEMENT. FOR UNPAVED INSTALLATIONS WHERE RUTTING FROM VEHICLES MAY OCCUR, INCREASE COVER TO 24" (600 mm).

THE INSTALLED CHAMBER SYSTEM SHALL PROVIDE THE LOAD FACTORS SPECIFIED IN THE AASHTO LRFD BRIDGE DESIGN SPECIFICATIONS SECTION 12.12 FOR EARTH AND LIVE LOADS, WITH CONSIDERATION FOR IMPACT AND MULTIPLE VEHICLE PRESENCES.



## SC-740 CUMULATIVE STORAGE VOLUMES PER CHAMBER

Assumes 40% Stone Porosity. Calculations are Based Upon a 6" (150 mm) Stone Base Under Chambers.

Depth of Water in System Inches (mm)		Cumulative Chamber Storage ft <sup>3</sup> (m <sup>3</sup> )	Total System Cumulative Storage ft <sup>3</sup> (m <sup>3</sup> )
42 (1067)		45.90 (1.300)	74.90 (2.121)
41 (1041)		45.90 (1.300)	73.77 (2.089)
40 (1016)		45.90 (1.300)	72.64 (2.057)
39 (991)	↑	45.90 (1.300)	71.52 (2.025)
38 (965)	Stone	45.90 (1.300)	70.39 (1.993)
37 (940)	Cover	45.90 (1.300)	69.26 (1.961)
36 (914)		45.90 (1.300)	68.14 (1.929)
35 (889)		45.85 (1.298)	66.98 (1.897)
34 (864)		45.69 (1.294)	65.75 (1.862)
33 (838)		45.41 (1.286)	64.46 (1.825)
32 (813)		44.81 (1.269)	62.97 (1.783)
31 (787)		44.01 (1.246)	61.36 (1.737)
30 (762)		43.06 (1.219)	59.66 (1.689)
29 (737)		41.98 (1.189)	57.89 (1.639)
28 (711)		40.80 (1.155)	56.05 (1.587)
27 (686)		39.54 (1.120)	54.17 (1.534)
26 (660)		38.18 (1.081)	52.23 (1.479)
25 (635)		36.74 (1.040)	50.23 (1.422)
24 (610)		35.22 (0.977)	48.19 (1.365)
23 (584)		33.64 (0.953)	46.11 (1.306)
22 (559)		31.99 (0.906)	44.00 (1.246)
21 (533)		30.29 (0.858)	41.85 (1.185)
20 (508)		28.54 (0.808)	39.67 (1.123)
19 (483)		26.74 (0.757)	37.47 (1.061)
18 (457)		24.89 (0.705)	35.23 (0.997)
17 (432)		23.00 (0.651)	32.96 (0.939)
16 (406)		21.06 (0.596)	30.68 (0.869)
15 (381)		19.09 (0.541)	28.36 (0.803)
14 (356)		17.08 (0.484)	26.03 (0.737)
13 (330)		15.04 (0.426)	23.68 (0.670)
12 (305)		12.97 (0.367)	21.31 (0.608)
11 (279)		10.87 (0.309)	18.92 (0.535)
10 (254)		8.74 (0.247)	16.51 (0.468)
9 (229)		6.58 (0.186)	14.09 (0.399)
8 (203)		4.41 (0.125)	11.66 (0.330)
7 (178)		2.21 (0.063)	9.21 (0.264)
6 (152)	↑	0 (0)	6.76 (0.191)
5 (127)		0 (0)	5.63 (0.160)
4 (102)	Stone	0 (0)	4.51 (0.128)
3 (76)	Foundation	0 (0)	3.38 (0.096)
2 (51)		0 (0)	2.25 (0.064)
1 (25)	↓	0 (0)	1.13 (0.032)

**Note:** Add 1.13 ft<sup>3</sup> (0.032 m<sup>3</sup>) of storage for each additional inch (25 mm) of stone foundation.

## Storage Volume Per Chamber ft<sup>3</sup> (m<sup>3</sup>)

	Bare Chamber Storage ft <sup>3</sup> (m <sup>3</sup> )	Chamber and Stone Foundation Depth in. (mm)		
		6 (150)	12 (300)	18 (450)
SC-740 Chamber	45.9 (1.3)	74.9 (2.1)	81.7 (2.3)	88.4 (2.5)

**Note:** Assumes 6" (150 mm) stone above chambers, 6" (150 mm) row spacing and 40% stone porosity.

## Amount of Stone Per Chamber

ENGLISH TONS (yds <sup>3</sup> )	Stone Foundation Depth		
	6"	12"	16"
SC-740	3.8 (2.8)	4.6 (3.3)	5.5 (3.9)
METRIC KILOGRAMS (m <sup>3</sup> )	150 mm	300 mm	450 mm
SC-740	3,450 (2.1)	4,170 (2.5)	4,490 (3.0)

**Note:** Assumes 6" (150 mm) of stone above and between chambers.

## Volume Excavation Per Chamber yd<sup>3</sup> (m<sup>3</sup>)

	Stone Foundation Depth		
	6 (150)	12 (300)	18 (450)
SC-740	5.5 (4.2)	6.2 (4.7)	6.8 (5.2)

**Note:** Assumes 6" (150 mm) of row separation and 18" (450 mm) of cover. The volume of excavation will vary as depth of cover increases.



# Isolator<sup>®</sup> Row O&M Manual



## THE ISOLATOR<sup>®</sup> ROW

### INTRODUCTION

An important component of any Stormwater Pollution Prevention Plan is inspection and maintenance. The StormTech Isolator Row is a technique to inexpensively enhance Total Suspended Solids (TSS) removal and provide easy access for inspection and maintenance.

### THE ISOLATOR ROW

The Isolator Row is a row of StormTech chambers, either SC-160LP, SC-310, SC-310-3, SC-740, DC-780, MC-3500 or MC-4500 models, that is surrounded with filter fabric and connected to a closely located manhole for easy access. The fabric-wrapped chambers provide for settling and filtration of sediment as storm water rises in the Isolator Row and ultimately passes through the filter fabric. The open bottom chambers and perforated sidewalls (SC-310, SC-310-3 and SC-740 models) allow storm water to flow both vertically and horizontally out of the chambers. Sediments are captured in the Isolator Row protecting the storage areas of the adjacent stone and chambers from sediment accumulation.

Two different fabrics are used for the Isolator Row. A woven geotextile fabric is placed between the stone and the Isolator Row chambers. The tough geotextile provides a media for storm water filtration and provides a durable surface for maintenance operations. It is also designed to prevent scour of the underlying stone and remain intact during high pressure jetting. A non-woven fabric is placed over the chambers to provide a filter media for flows passing through the perforations in the sidewall of the chamber. The non-woven fabric is not required over the SC-160LP, DC-780, MC-3500 or MC-4500 models as these chambers do not have perforated side walls.

The Isolator Row is typically designed to capture the “first flush” and offers the versatility to be sized on a volume basis or flow rate basis. An upstream manhole not only provides access to the Isolator Row but typically includes a high flow weir such that storm water flowrates or volumes that exceed the capacity of the Isolator Row overtop the overflow weir and discharge through a manifold to the other chambers.

The Isolator Row may also be part of a treatment train. By treating storm water prior to entry into the chamber system, the service life can be extended and pollutants such as hydrocarbons can be captured. Pre-treatment best management practices can be as simple as deep sump catch basins, oil-water separators or can be innovative storm water treatment devices. The design of the treatment train and selection of pretreatment devices by the design engineer is often driven by regulatory requirements. Whether pretreatment is used or not, the Isolator Row is recommended by StormTech as an effective means to minimize maintenance requirements and maintenance costs.

*Note: See the StormTech Design Manual for detailed information on designing inlets for a StormTech system, including the Isolator Row.*



Looking down the Isolator Row from the manhole opening, woven geotextile is shown between the chamber and stone base.



StormTech Isolator Row with Overflow Spillway (not to scale)

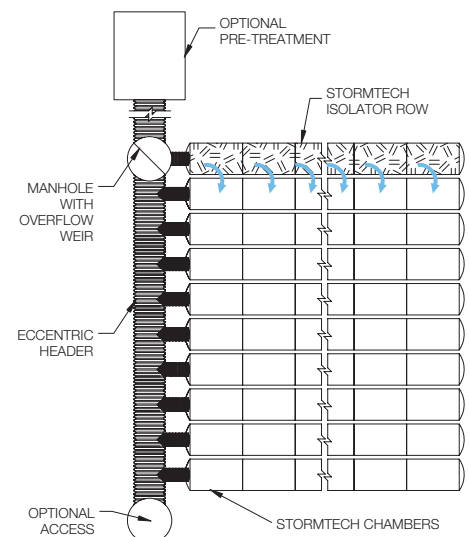



## ISOLATOR ROW INSPECTION/MAINTENANCE

### INSPECTION

The frequency of inspection and maintenance varies by location. A routine inspection schedule needs to be established for each individual location based upon site specific variables. The type of land use (i.e. industrial, commercial, residential), anticipated pollutant load, percent imperviousness, climate, etc. all play a critical role in determining the actual frequency of inspection and maintenance practices.

At a minimum, StormTech recommends annual inspections. Initially, the Isolator Row should be inspected every 6 months for the first year of operation. For subsequent years, the inspection should be adjusted based upon previous observation of sediment deposition.

The Isolator Row incorporates a combination of standard manhole(s) and strategically located inspection ports (as needed). The inspection ports allow for easy access to the system from the surface, eliminating the need to perform a confined space entry for inspection purposes.

If upon visual inspection it is found that sediment has accumulated, a stadia rod should be inserted to determine the depth of sediment. When the average depth of sediment exceeds 3 inches throughout the length of the Isolator Row, clean-out should be performed.

### MAINTENANCE

The Isolator Row was designed to reduce the cost of periodic maintenance. By “isolating” sediments to just one row, costs are dramatically reduced by eliminating the need to clean out each row of the entire storage bed. If inspection indicates the potential need for maintenance, access is provided via a manhole(s) located on the end(s) of the row for cleanout. If entry into the manhole is required, please follow local and OSHA rules for a confined space entries.

Maintenance is accomplished with the JetVac process. The JetVac process utilizes a high pressure water nozzle to propel itself down the Isolator Row while scouring and suspending sediments. As the nozzle is retrieved, the captured pollutants are flushed back into the manhole for vacuuming. Most sewer and pipe maintenance companies have vacuum/JetVac combination vehicles. Selection of an appropriate JetVac nozzle will improve maintenance efficiency. Fixed nozzles designed for culverts or large diameter pipe cleaning are preferable. Rear facing jets with an effective spread of at least 45” are best. Most JetVac reels have 400 feet of hose allowing maintenance of an Isolator Row up to 50 chambers long. **The JetVac process shall only be performed on StormTech Isolator Rows that have AASHTO class 1 woven geotextile (as specified by StormTech) over their angular base stone.**

### StormTech Isolator Row (not to scale)

*Note: Non-woven fabric is only required over the inlet pipe connection into the end cap for SC-160LP, DC-780, MC-3500 and MC-4500 chamber models and is not required over the entire Isolator Row.*

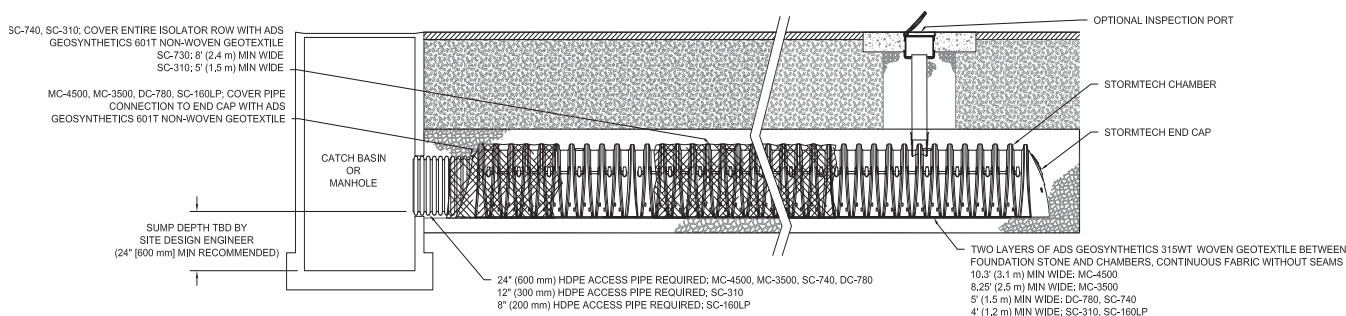

# ISOLATOR ROW STEP BY STEP MAINTENANCE PROCEDURES

## STEP 1

Inspect Isolator Row for sediment.

- A) Inspection ports (if present)
  - i. Remove lid from floor box frame
  - ii. Remove cap from inspection riser
  - iii. Using a flashlight and stadia rod, measure depth of sediment and record results on maintenance log.
  - iv. If sediment is at or above 3 inch depth, proceed to Step 2. If not, proceed to Step 3.
- B) All Isolator Rows
  - i. Remove cover from manhole at upstream end of Isolator Row
  - ii. Using a flashlight, inspect down Isolator Row through outlet pipe
    - 1. Mirrors on poles or cameras may be used to avoid a confined space entry
    - 2. Follow OSHA regulations for confined space entry if entering manhole
  - iii. If sediment is at or above the lower row of sidewall holes (approximately 3 inches), proceed to Step 2. If not, proceed to Step 3.

## STEP 2

Clean out Isolator Row using the JetVac process.

- A) A fixed floor cleaning nozzle with rear facing nozzle spread of 45 inches or more is preferable
- B) Apply multiple passes of JetVac until backflush water is clean
- C) Vacuum manhole sump as required

## STEP 3

Replace all caps, lids and covers, record observations and actions.

## STEP 4

Inspect & clean catch basins and manholes upstream of the StormTech system.

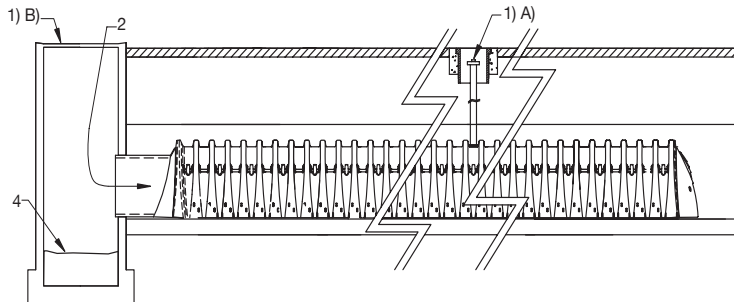

## SAMPLE MAINTENANCE LOG

Date	Stadia Rod Readings		Sediment Depth (1)-(2)	Observations/Actions	Inspector
	Fixed point to chamber bottom (1)	Fixed point to top of sediment (2)			
3/15/11	6.3 ft	none		New installation. Fixed point is CI frame at grade	DJM
9/24/11		6.2	0.1 ft	Some grit felt	SM
6/20/13		5.8	0.5 ft	Mucky feel, debris visible in manhole and in Isolator Row, maintenance due	NV
7/7/13	6.3 ft		0	System jetted and vacuumed	DJM

PROJECT INFORMATION	
ENGINEERED PRODUCT MANAGER:	HAIDER NASRULLAH 647-850-9417 HAIDER.NASRULLAH@ADS-PIPE.COM
ADS SALES REP:	MICHAEL REID 613-882-4186 MICHAEL.REID@ADS-PIPE.COM
PROJECT NO:	S188516
ADS SITE COORDINATOR:	MATTHEW BEGHIN 519-710-3687 MATTHEW.BEGHIN@ADS-PIPE.COM



ADVANCED DRAINAGE SYSTEMS, INC.

**SiteASSIST™**  
by StormTech  
FOR STORMTECH  
INSTRUCTIONS,  
DOWNLOAD THE  
INSTALLATION APP



# HARD ROCK OTTAWA

## OTTAWA, ON.

### SC-740 STORMTECH CHAMBER SPECIFICATIONS

- CHAMBERS SHALL BE STORMTECH SC-740.
- CHAMBERS SHALL BE ARCH-SHAPED AND SHALL BE MANUFACTURED FROM VIRGIN, IMPACT-MODIFIED POLYPROPYLENE COPOLYMERS.
- CHAMBERS SHALL BE CERTIFIED TO CSA B184, "POLYMERIC SUB-SURFACE STORMWATER MANAGEMENT STRUCTURES", AND MEET THE REQUIREMENTS OF ASTM F2418-16a, "STANDARD SPECIFICATION FOR POLYPROPYLENE (PP) CORRUGATED WALL STORMWATER COLLECTION CHAMBERS".
- CHAMBER ROWS SHALL PROVIDE CONTINUOUS, UNOBSTRUCTED INTERNAL SPACE WITH NO INTERNAL SUPPORTS THAT WOULD IMPEDE FLOW OR LIMIT ACCESS FOR INSPECTION.
- THE STRUCTURAL DESIGN OF THE CHAMBERS, THE STRUCTURAL BACKFILL, AND THE INSTALLATION REQUIREMENTS SHALL ENSURE THAT THE LOAD FACTORS SPECIFIED IN THE AASHTO LRFD BRIDGE DESIGN SPECIFICATIONS, SECTION 12.12, ARE MET FOR: 1) LONG-DURATION DEAD LOADS AND 2) SHORT-DURATION LIVE LOADS, BASED ON THE CSA S6 CL-625 TRUCK AND THE AASHTO DESIGN TRUCK WITH CONSIDERATION FOR IMPACT AND MULTIPLE VEHICLE PRESENCES.
- CHAMBERS SHALL BE DESIGNED, TESTED AND ALLOWABLE LOAD CONFIGURATIONS DETERMINED IN ACCORDANCE WITH ASTM F2787, "STANDARD PRACTICE FOR STRUCTURAL DESIGN OF THERMOPLASTIC CORRUGATED WALL STORMWATER COLLECTION CHAMBERS". LOAD CONFIGURATIONS SHALL INCLUDE: 1) INSTANTANEOUS (<1 MIN) AASHTO DESIGN TRUCK LIVE LOAD ON MINIMUM COVER 2) MAXIMUM PERMANENT (75-YR) COVER LOAD AND 3) ALLOWABLE COVER WITH PARKED (1-WEEK) AASHTO DESIGN TRUCK.
- REQUIREMENTS FOR HANDLING AND INSTALLATION:
  - TO MAINTAIN THE WIDTH OF CHAMBERS DURING SHIPPING AND HANDLING, CHAMBERS SHALL HAVE INTEGRAL, INTERLOCKING STACKING LUGS.
  - TO ENSURE A SECURE JOINT DURING INSTALLATION AND BACKFILL, THE HEIGHT OF THE CHAMBER JOINT SHALL NOT BE LESS THAN 50 mm (2").
  - TO ENSURE THE INTEGRITY OF THE ARCH SHAPE DURING INSTALLATION, a) THE ARCH STIFFNESS CONSTANT AS DEFINED IN SECTION 6.2.8 OF ASTM F2418 SHALL BE GREATER THAN OR EQUAL TO 550 LBS/IN/IN. AND b) TO RESIST CHAMBER DEFORMATION DURING INSTALLATION AT ELEVATED TEMPERATURES (ABOVE 23° C / 73° F), CHAMBERS SHALL BE PRODUCED FROM REFLECTIVE GOLD OR YELLOW COLORS.
- ONLY CHAMBERS THAT ARE APPROVED BY THE SITE DESIGN ENGINEER WILL BE ALLOWED. UPON REQUEST BY THE SITE DESIGN ENGINEER OR OWNER, THE CHAMBER MANUFACTURER SHALL SUBMIT A STRUCTURAL EVALUATION FOR APPROVAL BEFORE DELIVERING CHAMBERS TO THE PROJECT SITE AS FOLLOWS:
  - THE STRUCTURAL EVALUATION SHALL BE SEALED BY A REGISTERED PROFESSIONAL ENGINEER.
  - THE STRUCTURAL EVALUATION SHALL DEMONSTRATE THAT THE SAFETY FACTORS ARE GREATER THAN OR EQUAL TO 1.95 FOR DEAD LOAD AND 1.75 FOR LIVE LOAD, THE MINIMUM REQUIRED BY ASTM F2787 AND BY SECTIONS 3 AND 12.12 OF THE AASHTO LRFD BRIDGE DESIGN SPECIFICATIONS FOR THERMOPLASTIC PIPE.
  - THE TEST DERIVED CREEP MODULUS AS SPECIFIED IN ASTM F2418 SHALL BE USED FOR PERMANENT DEAD LOAD DESIGN EXCEPT THAT IT SHALL BE THE 75-YEAR MODULUS USED FOR DESIGN.
- CHAMBERS AND END CAPS SHALL BE PRODUCED AT AN ISO 9001 CERTIFIED MANUFACTURING FACILITY.

### IMPORTANT - NOTES FOR THE BIDDING AND INSTALLATION OF THE SC-740 SYSTEM

- STORMTECH SC-740 CHAMBERS SHALL NOT BE INSTALLED UNTIL THE MANUFACTURER'S REPRESENTATIVE HAS COMPLETED A PRE-CONSTRUCTION MEETING WITH THE INSTALLERS.
- STORMTECH SC-740 CHAMBERS SHALL BE INSTALLED IN ACCORDANCE WITH THE "STORMTECH SC-310/SC-740/DC-780 CONSTRUCTION GUIDE".
- CHAMBERS ARE NOT TO BE BACKFILLED WITH A DOZER OR AN EXCAVATOR SITUATED OVER THE CHAMBERS. STORMTECH RECOMMENDS 3 BACKFILL METHODS:
  - STONESHOOTER LOCATED OFF THE CHAMBER BED.
  - BACKFILL AS ROWS ARE BUILT USING AN EXCAVATOR ON THE FOUNDATION STONE OR SUBGRADE.
  - BACKFILL FROM OUTSIDE THE EXCAVATION USING A LONG BOOM HOE OR EXCAVATOR.
- THE FOUNDATION STONE SHALL BE LEVELED AND COMPACTED PRIOR TO PLACING CHAMBERS.
- JOINTS BETWEEN CHAMBERS SHALL BE PROPERLY SEATED PRIOR TO PLACING STONE.
- MAINTAIN MINIMUM - 150 mm (6") SPACING BETWEEN THE CHAMBER ROWS.
- EMBEDMENT STONE SURROUNDING CHAMBERS MUST BE A CLEAN, CRUSHED, ANGULAR STONE 20-50 mm (3/4-2").
- THE CONTRACTOR MUST REPORT ANY DISCREPANCIES WITH CHAMBER FOUNDATION MATERIALS BEARING CAPACITIES TO THE SITE DESIGN ENGINEER.
- ADS RECOMMENDS THE USE OF "FLEXSTORM CATCH IT" INSERTS DURING CONSTRUCTION FOR ALL INLETS TO PROTECT THE SUBSURFACE STORMWATER MANAGEMENT SYSTEM FROM CONSTRUCTION SITE RUNOFF.

### NOTES FOR CONSTRUCTION EQUIPMENT

- STORMTECH SC-740 CHAMBERS SHALL BE INSTALLED IN ACCORDANCE WITH THE "STORMTECH SC-310/SC-740/DC-780 CONSTRUCTION GUIDE".
- THE USE OF CONSTRUCTION EQUIPMENT OVER SC-740 CHAMBERS IS LIMITED:
  - NO EQUIPMENT IS ALLOWED ON BARE CHAMBERS.
  - NO RUBBER TIRE LOADERS, DUMP TRUCKS, OR EXCAVATORS ARE ALLOWED UNTIL PROPER FILL DEPTHS ARE REACHED IN ACCORDANCE WITH THE "STORMTECH SC-310/SC-740/DC-780 CONSTRUCTION GUIDE".
  - WEIGHT LIMITS FOR CONSTRUCTION EQUIPMENT CAN BE FOUND IN THE "STORMTECH SC-310/SC-740/DC-780 CONSTRUCTION GUIDE".
- FULL 900 mm (36") OF STABILIZED COVER MATERIALS OVER THE CHAMBERS IS REQUIRED FOR DUMP TRUCK TRAVEL OR DUMPING.

**USE OF A DOZER TO PUSH EMBEDMENT STONE BETWEEN THE ROWS OF CHAMBERS MAY CAUSE DAMAGE TO THE CHAMBERS AND IS NOT AN ACCEPTABLE BACKFILL METHOD. ANY CHAMBERS DAMAGED BY THE "DUMP AND PUSH" METHOD ARE NOT COVERED UNDER THE STORMTECH STANDARD WARRANTY.**

CONTACT STORMTECH AT 1-888-892-2694 WITH ANY QUESTIONS ON INSTALLATION REQUIREMENTS OR WEIGHT LIMITS FOR CONSTRUCTION EQUIPMENT.

**PROPOSED LAYOUT - SYSTEM 1**

30	STORMTECH SC-740 CHAMBERS
10	STORMTECH SC-740 END CAPS
152	STONE ABOVE (mm)
300	STONE BELOW (mm)
40	% STONE VOID
<b>65.0</b>	<b>INSTALLED SYSTEM VOLUME (m³) ABOVE ELEVATION 113.00 (PERIMETER STONE INCLUDED)</b>
<b>13.8</b>	<b>INSTALLED SYSTEM VOLUME (m³) BELOW ELEVATION 113.00 (PERIMETER STONE INCLUDED)</b>
113.7	SYSTEM AREA (m²)
44.9	SYSTEM PERIMETER (m)

**PROPOSED ELEVATIONS - SYSTEM 1**

116.197	MAXIMUM ALLOWABLE GRADE (TOP OF PAVEMENT/UNPAVED):
114.369	MINIMUM ALLOWABLE GRADE (UNPAVED WITH TRAFFIC):
114.216	MINIMUM ALLOWABLE GRADE (UNPAVED NO TRAFFIC):
114.216	MINIMUM ALLOWABLE GRADE (BASE OF FLEXIBLE PAVEMENT):
114.216	MINIMUM ALLOWABLE GRADE (TOP OF RIGID PAVEMENT):
113.911	TOP OF STONE:
113.759	TOP OF SC-740 CHAMBER:
113.314	300 mm TOP MANIFOLD INVERT:
113.000	600 mm ISOLATOR ROW INVERT:
112.997	BOTTOM OF SC-740 CHAMBER:
112.697	BOTTOM OF STONE:

**NOTES**

- MANIFOLD SIZE TO BE DETERMINED BY SITE DESIGN ENGINEER. SEE TECHNICAL NOTE 6.32 FOR MANIFOLD SIZING GUIDANCE.
- DUE TO THE ADAPTATION OF THIS CHAMBER SYSTEM TO SPECIFIC SITE AND DESIGN CONSTRAINTS, IT MAY BE NECESSARY TO CUT AND COUPLE ADDITIONAL PIPE TO STANDARD MANIFOLD COMPONENTS IN THE FIELD.
- THE SITE DESIGN ENGINEER MUST REVIEW ELEVATIONS AND IF NECESSARY ADJUST GRADING TO ENSURE THE CHAMBER COVER REQUIREMENTS ARE MET.
- THIS CHAMBER SYSTEM WAS DESIGNED WITHOUT SITE-SPECIFIC INFORMATION ON SOIL CONDITIONS OR BEARING CAPACITY. THE SITE DESIGN ENGINEER IS RESPONSIBLE FOR DETERMINING THE SUITABILITY OF THE SOIL AND PROVIDING THE BEARING CAPACITY OF THE INSITU SOILS. THE BASE STONE DEPTH MAY BE INCREASED OR DECREASED ONCE THIS INFORMATION IS PROVIDED..

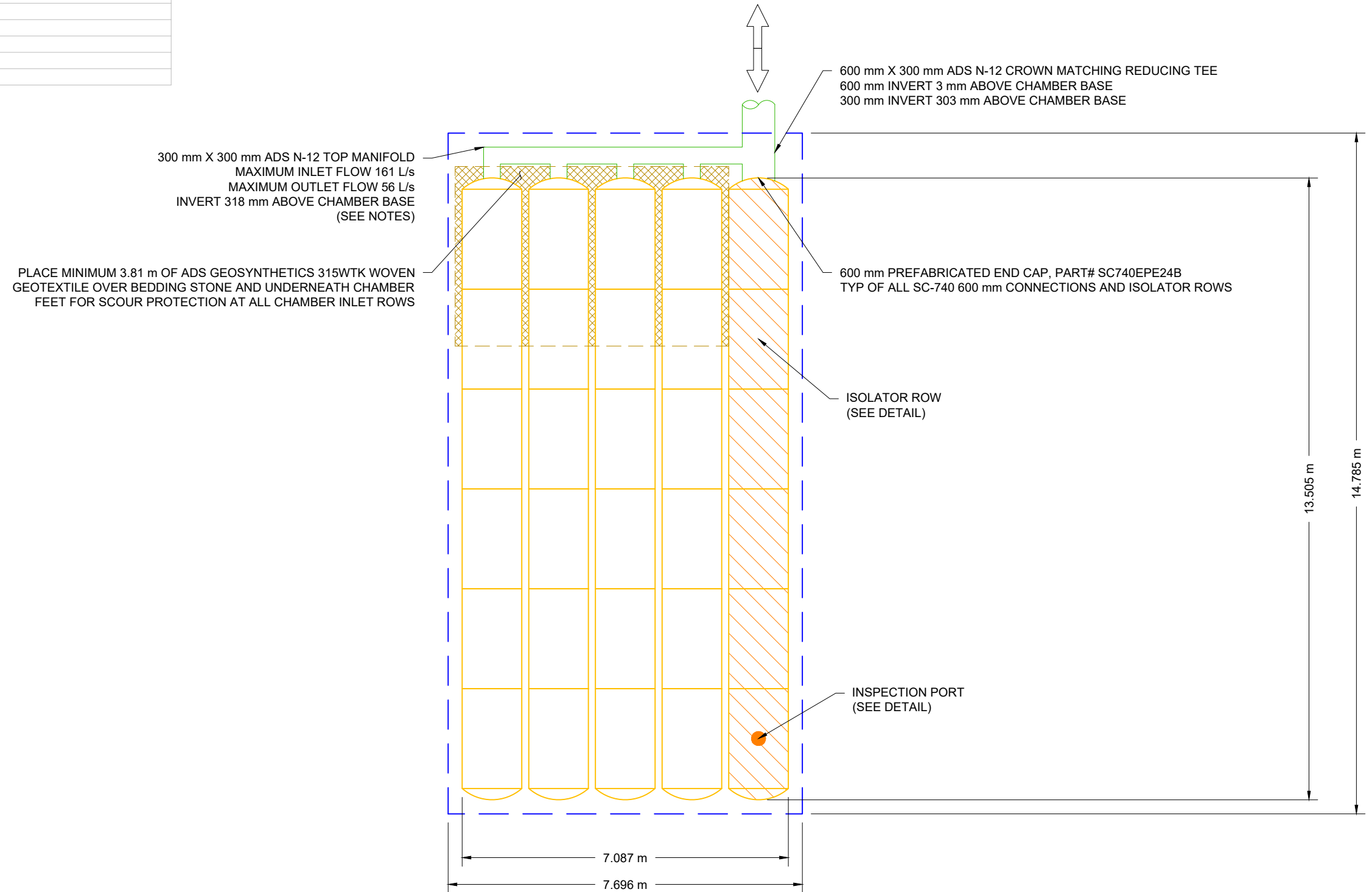

HARD ROCK OTTAWA

OTTAWA, ON.

DATE: 06/12/20 DRAWN: RCT

PROJECT #: S188516 CHECKED: JMQ

DATE	DRWN	CHKD	DESCRIPTION



520 CROMWELL AVENUE | ROCKY HILL | CT | 06067  
860-529-8188 | 888-892-2894 | WWW.STORMTECH.COM

4640 TRUEMAN BLVD  
HILLIARD, OH 43026



SCALE = 1 : 100

THIS DRAWING HAS BEEN PREPARED BASED ON INFORMATION PROVIDED TO ADS UNDER THE DIRECTION OF THE SITE DESIGN ENGINEER OR OTHER PROJECT REPRESENTATIVE. THE SITE DESIGN ENGINEER SHALL REVIEW THIS DRAWING PRIOR TO CONSTRUCTION. IT IS THE ULTIMATE RESPONSIBILITY OF THE SITE DESIGN ENGINEER TO ENSURE THAT THE PRODUCT(S) DEPICTED AND ALL ASSOCIATED DETAILS MEET ALL APPLICABLE LAWS, REGULATIONS, AND PROJECT REQUIREMENTS.

**PROPOSED LAYOUT - SYSTEM 2**

4	STORMTECH SC-740 CHAMBERS
4	STORMTECH SC-740 END CAPS
152	STONE ABOVE (mm)
300	STONE BELOW (mm)
40	% STONE VOID
<b>10.0</b>	<b>INSTALLED SYSTEM VOLUME (m<sup>3</sup>) ABOVE ELEVATION 113.490 (PERIMETER STONE INCLUDED)</b>
<b>3.0</b>	<b>INSTALLED SYSTEM VOLUME (m<sup>3</sup>) BELOW ELEVATION 113.490 (PERIMETER STONE INCLUDED)</b>
20.4	SYSTEM AREA (m <sup>2</sup> )
18.9	SYSTEM PERIMETER (m)

**PROPOSED ELEVATIONS - SYSTEM 2**

116.649	MAXIMUM ALLOWABLE GRADE (TOP OF PAVEMENT/UNPAVED):
114.821	MINIMUM ALLOWABLE GRADE (UNPAVED WITH TRAFFIC):
114.668	MINIMUM ALLOWABLE GRADE (UNPAVED NO TRAFFIC):
114.668	MINIMUM ALLOWABLE GRADE (BASE OF FLEXIBLE PAVEMENT):
114.668	MINIMUM ALLOWABLE GRADE (TOP OF RIGID PAVEMENT):
114.363	TOP OF STONE:
114.211	TOP OF SC-740 CHAMBER:
113.640	300 mm CUSTOM MANIFOLD INVERT:
113.490	450 mm ISOLATOR ROW INVERT:
113.449	BOTTOM OF SC-740 CHAMBER:
113.149	BOTTOM OF STONE:

**NOTES**

- MANIFOLD SIZE TO BE DETERMINED BY SITE DESIGN ENGINEER. SEE TECHNICAL NOTE 6.32 FOR MANIFOLD SIZING GUIDANCE.
- DUE TO THE ADAPTATION OF THIS CHAMBER SYSTEM TO SPECIFIC SITE AND DESIGN CONSTRAINTS, IT MAY BE NECESSARY TO CUT AND COUPLE ADDITIONAL PIPE TO STANDARD MANIFOLD COMPONENTS IN THE FIELD.
- THE SITE DESIGN ENGINEER MUST REVIEW ELEVATIONS AND IF NECESSARY ADJUST GRADING TO ENSURE THE CHAMBER COVER REQUIREMENTS ARE MET.
- THIS CHAMBER SYSTEM WAS DESIGNED WITHOUT SITE-SPECIFIC INFORMATION ON SOIL CONDITIONS OR BEARING CAPACITY. THE SITE DESIGN ENGINEER IS RESPONSIBLE FOR DETERMINING THE SUITABILITY OF THE SOIL AND PROVIDING THE BEARING CAPACITY OF THE INSITU SOILS. THE BASE STONE DEPTH MAY BE INCREASED OR DECREASED ONCE THIS INFORMATION IS PROVIDED..

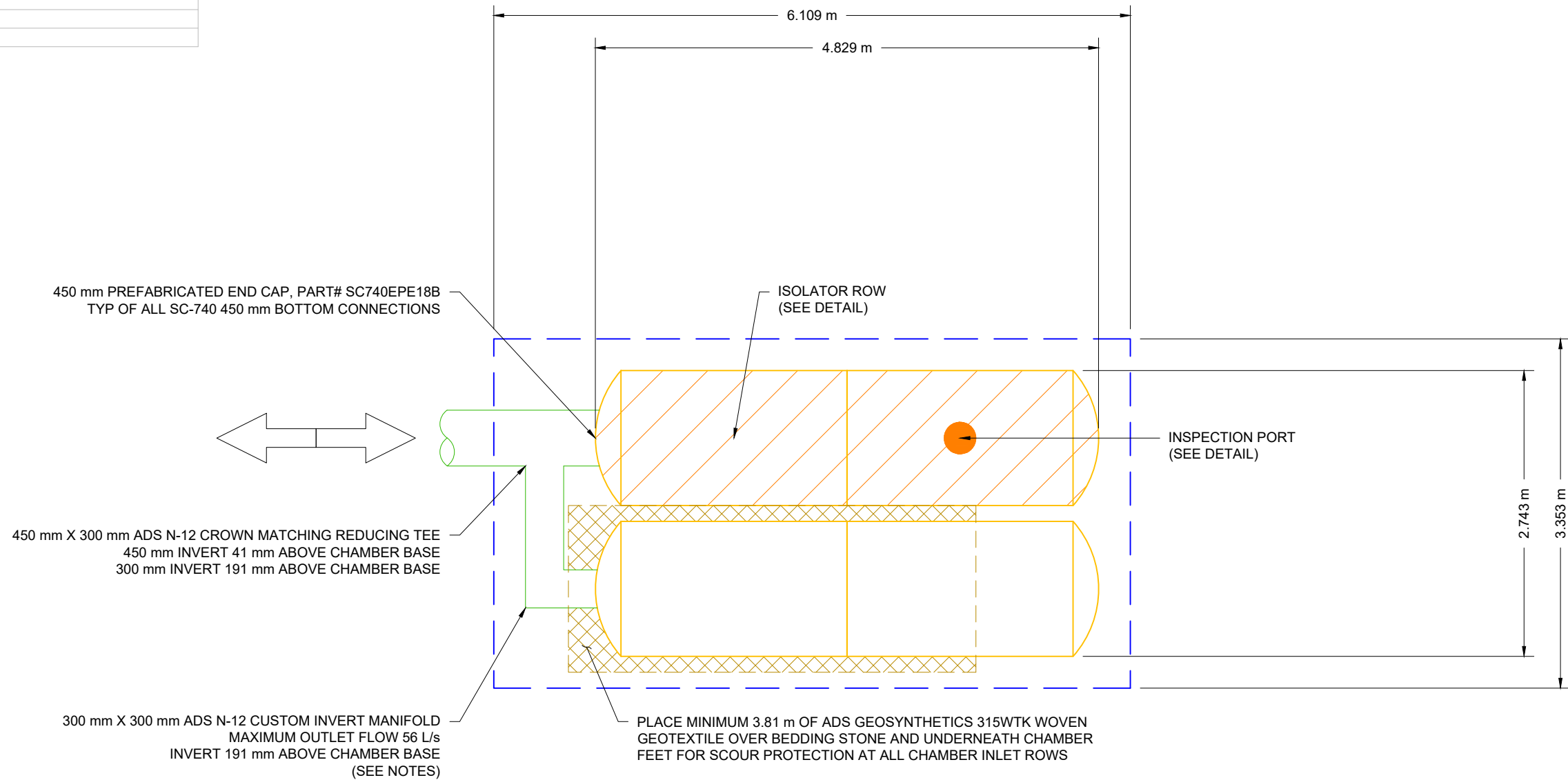

HARD ROCK OTTAWA

OTTAWA, ON.

DATE: 06/12/20 DRAWN: RCT

PROJECT #: S188516 CHECKED: JMQ



520 CROMWELL AVENUE | ROCKY HILL | CT | 06067  
860-529-8188 | 888-892-2894 | WWW.STORMTECH.COM



4640 TRUEMAN BLVD  
HILLIARD, OH 43026

SCALE = 1 : 50

THIS DRAWING HAS BEEN PREPARED BASED ON INFORMATION PROVIDED TO ADS UNDER THE DIRECTION OF THE SITE DESIGN ENGINEER OR OTHER PROJECT REPRESENTATIVE. THE SITE DESIGN ENGINEER SHALL REVIEW THIS DRAWING PRIOR TO CONSTRUCTION. IT IS THE ULTIMATE RESPONSIBILITY OF THE SITE DESIGN ENGINEER TO ENSURE THAT THE PRODUCT(S) DEPICTED AND ALL ASSOCIATED DETAILS MEET ALL APPLICABLE LAWS, REGULATIONS, AND PROJECT REQUIREMENTS.



**PROPOSED LAYOUT - SYSTEM 3**

70	STORMTECH SC-740 CHAMBERS
14	STORMTECH SC-740 END CAPS
152	STONE ABOVE (mm)
300	STONE BELOW (mm)
40	% STONE VOID
<b>150.4</b>	<b>INSTALLED SYSTEM VOLUME (m<sup>3</sup>) ABOVE ELEVATION 113.120 (PERIMETER STONE INCLUDED)</b>
<b>31.9</b>	<b>INSTALLED SYSTEM VOLUME (m<sup>3</sup>) BELOW ELEVATION 113.120 (PERIMETER STONE INCLUDED)</b>
261.8	SYSTEM AREA (m <sup>2</sup> )
69.6	SYSTEM PERIMETER (m)

**PROPOSED ELEVATIONS - SYSTEM 3**

116.317	MAXIMUM ALLOWABLE GRADE (TOP OF PAVEMENT/UNPAVED):
114.489	MINIMUM ALLOWABLE GRADE (UNPAVED WITH TRAFFIC):
114.336	MINIMUM ALLOWABLE GRADE (UNPAVED NO TRAFFIC):
114.336	MINIMUM ALLOWABLE GRADE (BASE OF FLEXIBLE PAVEMENT):
114.336	MINIMUM ALLOWABLE GRADE (TOP OF RIGID PAVEMENT):
114.031	TOP OF STONE:
113.879	TOP OF SC-740 CHAMBER:
113.435	300 mm TOP MANIFOLD INVERT:
113.120	600 mm ISOLATOR ROW INVERT:
113.117	BOTTOM OF SC-740 CHAMBER:
112.817	BOTTOM OF STONE:

**NOTES**

- MANIFOLD SIZE TO BE DETERMINED BY SITE DESIGN ENGINEER. SEE TECHNICAL NOTE 6.32 FOR MANIFOLD SIZING GUIDANCE.
- DUE TO THE ADAPTATION OF THIS CHAMBER SYSTEM TO SPECIFIC SITE AND DESIGN CONSTRAINTS, IT MAY BE NECESSARY TO CUT AND COUPLE ADDITIONAL PIPE TO STANDARD MANIFOLD COMPONENTS IN THE FIELD.
- THE SITE DESIGN ENGINEER MUST REVIEW ELEVATIONS AND IF NECESSARY ADJUST GRADING TO ENSURE THE CHAMBER COVER REQUIREMENTS ARE MET.
- THIS CHAMBER SYSTEM WAS DESIGNED WITHOUT SITE-SPECIFIC INFORMATION ON SOIL CONDITIONS OR BEARING CAPACITY. THE SITE DESIGN ENGINEER IS RESPONSIBLE FOR DETERMINING THE SUITABILITY OF THE SOIL AND PROVIDING THE BEARING CAPACITY OF THE INSITU SOILS. THE BASE STONE DEPTH MAY BE INCREASED OR DECREASED ONCE THIS INFORMATION IS PROVIDED..

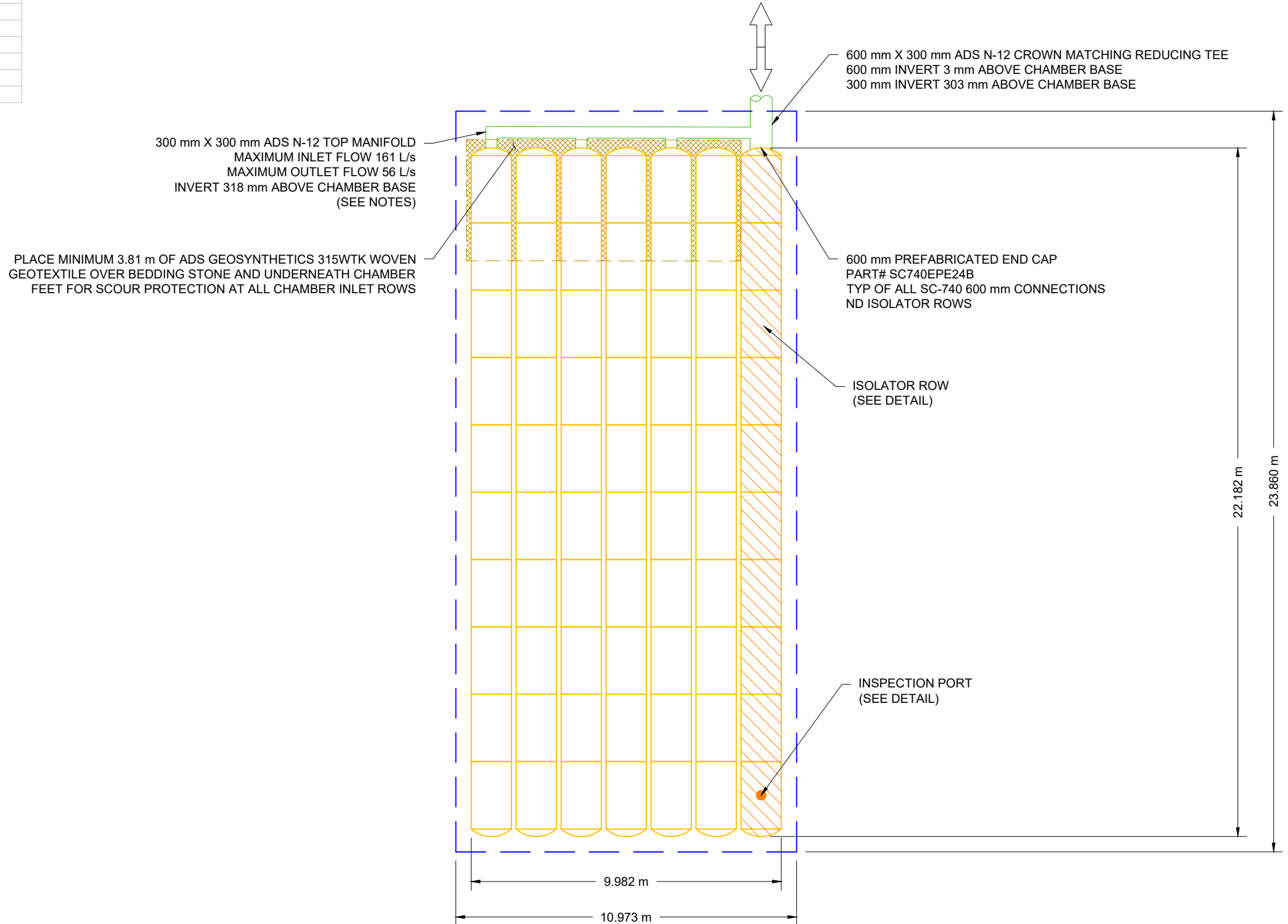

HARD ROCK OTTAWA  
OTTAWA, ON.

DATE: 06/12/20 DRAWN: RCT  
PROJECT #: S188516 CHECKED: JMQ

DATE	DRWN	CHKD	DESCRIPTION

ADS  
ADVANCED DRAINAGE SYSTEMS, INC.  
4640 TRUEMAN BLVD  
HILLIARD, OH 43026

SCALE = 1 : 150

THIS DRAWING HAS BEEN PREPARED BASED ON INFORMATION PROVIDED TO ADS UNDER THE DIRECTION OF THE SITE DESIGN ENGINEER OR OTHER PROJECT REPRESENTATIVE. THE SITE DESIGN ENGINEER SHALL REVIEW THIS DRAWING PRIOR TO CONSTRUCTION. IT IS THE ULTIMATE RESPONSIBILITY OF THE SITE DESIGN ENGINEER TO ENSURE THAT THE PRODUCT(S) DEPICTED AND ALL ASSOCIATED DETAILS MEET ALL APPLICABLE LAWS, REGULATIONS, AND PROJECT REQUIREMENTS.

**PROPOSED LAYOUT - SYSTEM 4**

70	STORMTECH SC-740 CHAMBERS
14	STORMTECH SC-740 END CAPS
152	STONE ABOVE (mm)
300	STONE BELOW (mm)
40	% STONE VOID
<b>150.5</b>	<b>INSTALLED SYSTEM VOLUME (m<sup>3</sup>) ABOVE ELEVATION 113.510 (PERIMETER STONE INCLUDED)</b>
<b>31.9</b>	<b>INSTALLED SYSTEM VOLUME (m<sup>3</sup>) BELOW ELEVATION 113.510 (PERIMETER STONE INCLUDED)</b>
261.8	SYSTEM AREA (m <sup>2</sup> )
69.6	SYSTEM PERIMETER (m)

**PROPOSED ELEVATIONS - SYSTEM 4**

116.707	MAXIMUM ALLOWABLE GRADE (TOP OF PAVEMENT/UNPAVED):
114.879	MINIMUM ALLOWABLE GRADE (UNPAVED WITH TRAFFIC):
114.726	MINIMUM ALLOWABLE GRADE (UNPAVED NO TRAFFIC):
114.726	MINIMUM ALLOWABLE GRADE (BASE OF FLEXIBLE PAVEMENT):
114.726	MINIMUM ALLOWABLE GRADE (TOP OF RIGID PAVEMENT):
114.421	TOP OF STONE:
114.269	TOP OF SC-740 CHAMBER:
113.825	300 mm TOP MANIFOLD INVERT:
113.510	600 mm ISOLATOR ROW INVERT:
113.507	BOTTOM OF SC-740 CHAMBER:
113.207	BOTTOM OF STONE:

**NOTES**

- MANIFOLD SIZE TO BE DETERMINED BY SITE DESIGN ENGINEER. SEE TECHNICAL NOTE 6.32 FOR MANIFOLD SIZING GUIDANCE.
- DUE TO THE ADAPTATION OF THIS CHAMBER SYSTEM TO SPECIFIC SITE AND DESIGN CONSTRAINTS, IT MAY BE NECESSARY TO CUT AND COUPLE ADDITIONAL PIPE TO STANDARD MANIFOLD COMPONENTS IN THE FIELD.
- THE SITE DESIGN ENGINEER MUST REVIEW ELEVATIONS AND IF NECESSARY ADJUST GRADING TO ENSURE THE CHAMBER COVER REQUIREMENTS ARE MET.
- THIS CHAMBER SYSTEM WAS DESIGNED WITHOUT SITE-SPECIFIC INFORMATION ON SOIL CONDITIONS OR BEARING CAPACITY. THE SITE DESIGN ENGINEER IS RESPONSIBLE FOR DETERMINING THE SUITABILITY OF THE SOIL AND PROVIDING THE BEARING CAPACITY OF THE INSITU SOILS. THE BASE STONE DEPTH MAY BE INCREASED OR DECREASED ONCE THIS INFORMATION IS PROVIDED..

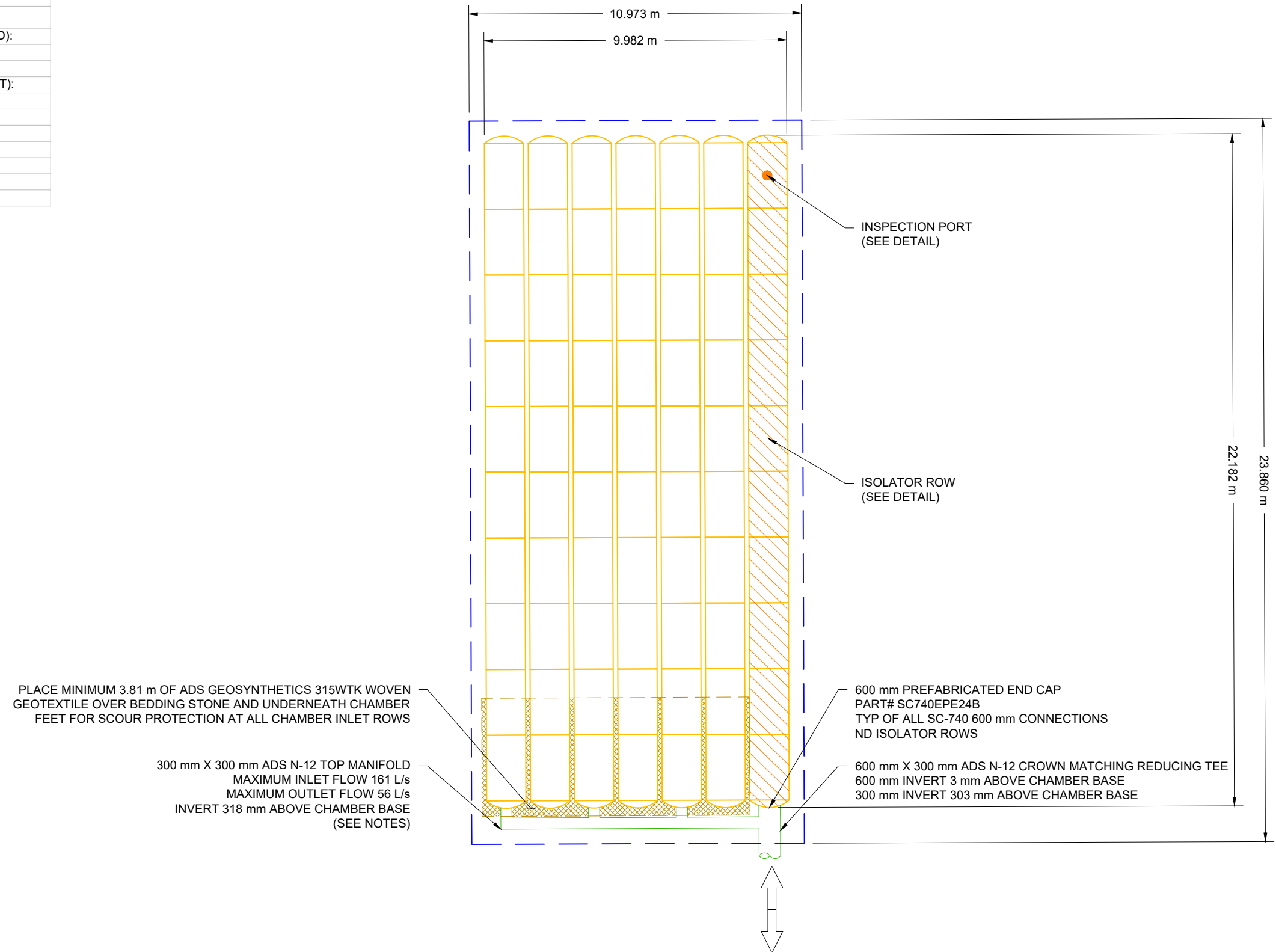

HARD ROCK OTTAWA OTTAWA, ON.		DATE: 06/12/20	DRAWN: RCT
		PROJECT #: S188516	CHECKED: JMQ
		DATE	DESCRIPTION
		DRWN	CHKD
 520 CROMWELL AVENUE   ROCKY HILL   CT   06067 860-529-8188   888-892-2894   WWW.STORMTECH.COM		THIS DRAWING HAS BEEN PREPARED BASED ON INFORMATION PROVIDED TO ADS UNDER THE DIRECTION OF THE SITE DESIGN ENGINEER OR OTHER PROJECT REPRESENTATIVE. THE SITE DESIGN ENGINEER SHALL REVIEW THIS DRAWING PRIOR TO CONSTRUCTION. IT IS THE ULTIMATE RESPONSIBILITY OF THE SITE DESIGN ENGINEER TO ENSURE THAT THE PRODUCT(S) DEPICTED AND ALL ASSOCIATED DETAILS MEET ALL APPLICABLE LAWS, REGULATIONS, AND PROJECT REQUIREMENTS.	
4640 TRUEMAN BLVD HILLIARD, OH 43026  ADVANCED DRAINAGE SYSTEMS, INC.		SCALE = 1 : 150	
5		SHEET OF 24	

**PROPOSED LAYOUT - SYSTEM 5**

40	STORMTECH SC-740 CHAMBERS
10	STORMTECH SC-740 END CAPS
152	STONE ABOVE (mm)
300	STONE BELOW (mm)
40	% STONE VOID
<b>85.8</b>	<b>INSTALLED SYSTEM VOLUME (m³) ABOVE ELEVATION 113.89 (PERIMETER STONE INCLUDED)</b>
<b>18.1</b>	<b>INSTALLED SYSTEM VOLUME (m³) BELOW ELEVATION 113.89 (PERIMETER STONE INCLUDED)</b>
149.1	SYSTEM AREA (m²)
53.9	SYSTEM PERIMETER (m)

**PROPOSED ELEVATIONS - SYSTEM 5**

117.087	MAXIMUM ALLOWABLE GRADE (TOP OF PAVEMENT/UNPAVED):
115.259	MINIMUM ALLOWABLE GRADE (UNPAVED WITH TRAFFIC):
115.106	MINIMUM ALLOWABLE GRADE (UNPAVED NO TRAFFIC):
115.106	MINIMUM ALLOWABLE GRADE (BASE OF FLEXIBLE PAVEMENT):
115.106	MINIMUM ALLOWABLE GRADE (TOP OF RIGID PAVEMENT):
114.801	TOP OF STONE:
114.649	TOP OF SC-740 CHAMBER:
114.205	300 mm TOP MANIFOLD INVERT:
113.890	600 mm ISOLATOR ROW INVERT:
113.887	BOTTOM OF SC-740 CHAMBER:
113.587	BOTTOM OF STONE:

**NOTES**

- MANIFOLD SIZE TO BE DETERMINED BY SITE DESIGN ENGINEER. SEE TECHNICAL NOTE 6.32 FOR MANIFOLD SIZING GUIDANCE.
- DUE TO THE ADAPTATION OF THIS CHAMBER SYSTEM TO SPECIFIC SITE AND DESIGN CONSTRAINTS, IT MAY BE NECESSARY TO CUT AND COUPLE ADDITIONAL PIPE TO STANDARD MANIFOLD COMPONENTS IN THE FIELD.
- THE SITE DESIGN ENGINEER MUST REVIEW ELEVATIONS AND IF NECESSARY ADJUST GRADING TO ENSURE THE CHAMBER COVER REQUIREMENTS ARE MET.
- THIS CHAMBER SYSTEM WAS DESIGNED WITHOUT SITE-SPECIFIC INFORMATION ON SOIL CONDITIONS OR BEARING CAPACITY. THE SITE DESIGN ENGINEER IS RESPONSIBLE FOR DETERMINING THE SUITABILITY OF THE SOIL AND PROVIDING THE BEARING CAPACITY OF THE INSITU SOILS. THE BASE STONE DEPTH MAY BE INCREASED OR DECREASED ONCE THIS INFORMATION IS PROVIDED..

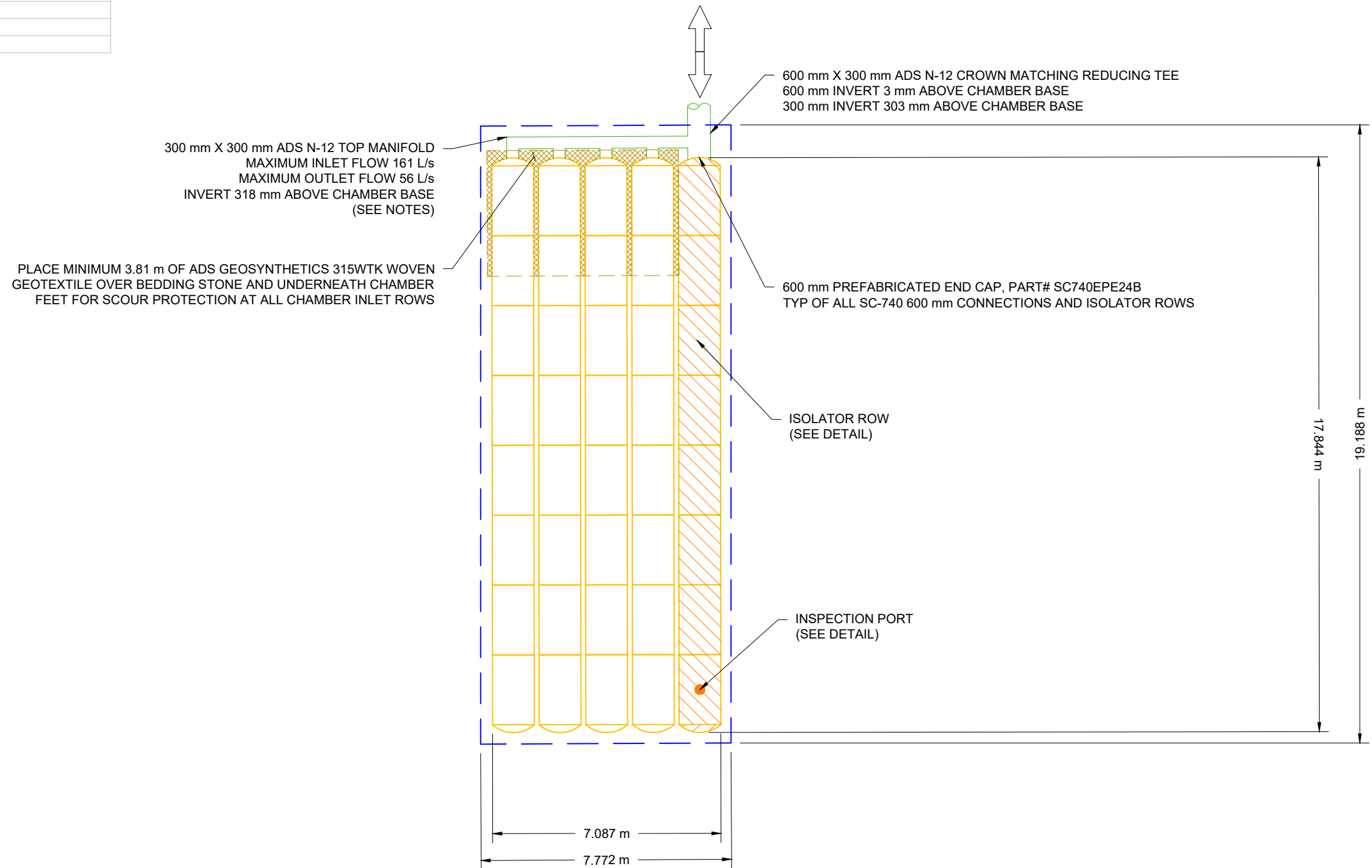

HARD ROCK OTTAWA	
OTTAWA, ON.	
DATE: 06/12/20	DRAWN: RCT
PROJECT #: S188516	CHECKED: JMQ

DATE	DRWN	CHKD	DESCRIPTION

**StormTech**  
 Retention • Retention • Water Quality  
 520 CROMWELL AVENUE | ROCKY HILL | CT | 06067  
 860-529-8188 | 888-892-2894 | WWW.STORMTECH.COM

**ADS**  
 ADVANCED DRAINAGE SYSTEMS, INC.  
 4640 TRUEMAN BLVD  
 HILLIARD, OH 43026

SCALE = 1 : 150

THIS DRAWING HAS BEEN PREPARED BASED ON INFORMATION PROVIDED TO ADS UNDER THE DIRECTION OF THE SITE DESIGN ENGINEER OR OTHER PROJECT REPRESENTATIVE. THE SITE DESIGN ENGINEER SHALL REVIEW THIS DRAWING PRIOR TO CONSTRUCTION. IT IS THE ULTIMATE RESPONSIBILITY OF THE SITE DESIGN ENGINEER TO ENSURE THAT THE PRODUCT(S) DEPICTED AND ALL ASSOCIATED DETAILS MEET ALL APPLICABLE LAWS, REGULATIONS, AND PROJECT REQUIREMENTS.

**PROPOSED LAYOUT - SYSTEM 6**

40	STORMTECH SC-740 CHAMBERS
10	STORMTECH SC-740 END CAPS
152	STONE ABOVE (mm)
300	STONE BELOW (mm)
40	% STONE VOID
<b>85.8</b>	<b>INSTALLED SYSTEM VOLUME (m³) ABOVE ELEVATION 111.620 (PERIMETER STONE INCLUDED)</b>
<b>18.1</b>	<b>INSTALLED SYSTEM VOLUME (m³) BELOW ELEVATION 111.620 (PERIMETER STONE INCLUDED)</b>
149.1	SYSTEM AREA (m²)
53.6	SYSTEM PERIMETER (m)

**PROPOSED ELEVATIONS - SYSTEM 6**

114.817	MAXIMUM ALLOWABLE GRADE (TOP OF PAVEMENT/UNPAVED):
112.989	MINIMUM ALLOWABLE GRADE (UNPAVED WITH TRAFFIC):
112.836	MINIMUM ALLOWABLE GRADE (UNPAVED NO TRAFFIC):
112.836	MINIMUM ALLOWABLE GRADE (BASE OF FLEXIBLE PAVEMENT):
112.836	MINIMUM ALLOWABLE GRADE (TOP OF RIGID PAVEMENT):
112.531	TOP OF STONE:
112.379	TOP OF SC-740 CHAMBER:
111.935	300 mm TOP MANIFOLD INVERT:
111.620	600 mm ISOLATOR ROW INVERT:
111.617	BOTTOM OF SC-740 CHAMBER:
111.317	BOTTOM OF STONE:

**NOTES**

- MANIFOLD SIZE TO BE DETERMINED BY SITE DESIGN ENGINEER. SEE TECHNICAL NOTE 6.32 FOR MANIFOLD SIZING GUIDANCE.
- DUE TO THE ADAPTATION OF THIS CHAMBER SYSTEM TO SPECIFIC SITE AND DESIGN CONSTRAINTS, IT MAY BE NECESSARY TO CUT AND COUPLE ADDITIONAL PIPE TO STANDARD MANIFOLD COMPONENTS IN THE FIELD.
- THE SITE DESIGN ENGINEER MUST REVIEW ELEVATIONS AND IF NECESSARY ADJUST GRADING TO ENSURE THE CHAMBER COVER REQUIREMENTS ARE MET.
- THIS CHAMBER SYSTEM WAS DESIGNED WITHOUT SITE-SPECIFIC INFORMATION ON SOIL CONDITIONS OR BEARING CAPACITY. THE SITE DESIGN ENGINEER IS RESPONSIBLE FOR DETERMINING THE SUITABILITY OF THE SOIL AND PROVIDING THE BEARING CAPACITY OF THE INSITU SOILS. THE BASE STONE DEPTH MAY BE INCREASED OR DECREASED ONCE THIS INFORMATION IS PROVIDED..

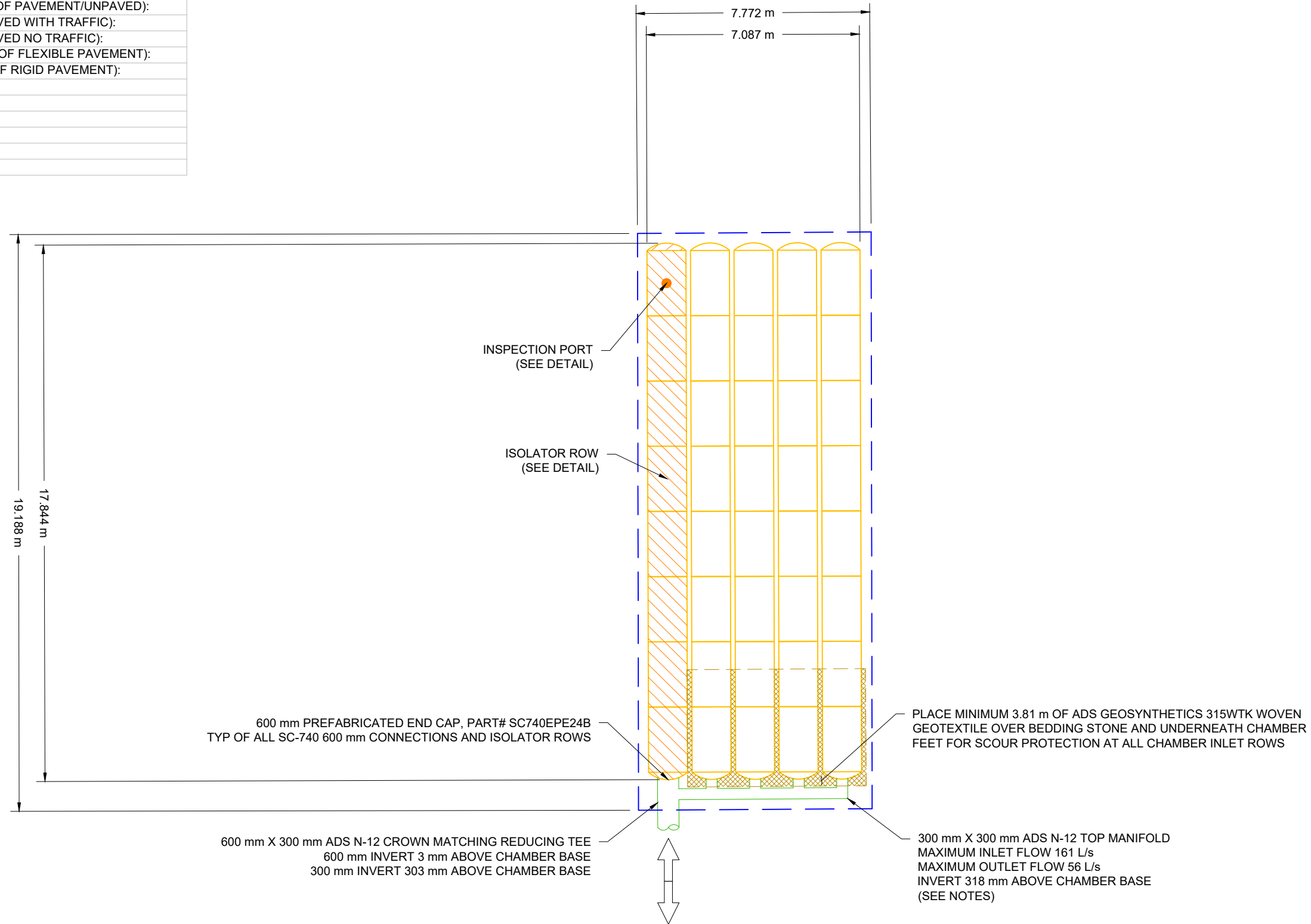

HARD ROCK OTTAWA	
OTTAWA, ON.	
DATE: 06/12/20	DRAWN: RCT
PROJECT #: S188516	CHECKED: JMQ

DATE	DRWN	CHKD	DESCRIPTION

**StormTech**  
 Retention • Retention • Water Quality  
 520 CROMWELL AVENUE | ROCKY HILL | CT | 06067  
 860-529-8188 | 888-892-2894 | WWW.STORMTECH.COM

4640 TRUEMAN BLVD  
 HILLIARD, OH 43026

**ADS**  
 ADVANCED DRAINAGE SYSTEMS, INC.

**SCALE = 1 : 150**

THIS DRAWING HAS BEEN PREPARED BASED ON INFORMATION PROVIDED TO ADS UNDER THE DIRECTION OF THE SITE DESIGN ENGINEER OR OTHER PROJECT REPRESENTATIVE. THE SITE DESIGN ENGINEER SHALL REVIEW THIS DRAWING PRIOR TO CONSTRUCTION. IT IS THE ULTIMATE RESPONSIBILITY OF THE SITE DESIGN ENGINEER TO ENSURE THAT THE PRODUCT(S) DEPICTED AND ALL ASSOCIATED DETAILS MEET ALL APPLICABLE LAWS, REGULATIONS, AND PROJECT REQUIREMENTS.

**PROPOSED LAYOUT - SYSTEM 7**

4	STORMTECH SC-740 CHAMBERS
4	STORMTECH SC-740 END CAPS
152	STONE ABOVE (mm)
300	STONE BELOW (mm)
40	% STONE VOID
<b>10.0</b>	<b>INSTALLED SYSTEM VOLUME (m³) ABOVE ELEVATION 111.800 (PERIMETER STONE INCLUDED)</b>
<b>3.0</b>	<b>INSTALLED SYSTEM VOLUME (m³) BELOW ELEVATION 111.800 (PERIMETER STONE INCLUDED)</b>
20.4	SYSTEM AREA (m²)
18.9	SYSTEM PERIMETER (m)

**PROPOSED ELEVATIONS - SYSTEM 7**

114.959	MAXIMUM ALLOWABLE GRADE (TOP OF PAVEMENT/UNPAVED):
113.131	MINIMUM ALLOWABLE GRADE (UNPAVED WITH TRAFFIC):
112.978	MINIMUM ALLOWABLE GRADE (UNPAVED NO TRAFFIC):
112.978	MINIMUM ALLOWABLE GRADE (BASE OF FLEXIBLE PAVEMENT):
112.978	MINIMUM ALLOWABLE GRADE (TOP OF RIGID PAVEMENT):
112.673	TOP OF STONE:
112.521	TOP OF SC-740 CHAMBER:
111.950	300 mm CUSTOM MANIFOLD INVERT:
111.800	450 mm ISOLATOR ROW INVERT:
111.759	BOTTOM OF SC-740 CHAMBER:
111.459	BOTTOM OF STONE:

**NOTES**

- MANIFOLD SIZE TO BE DETERMINED BY SITE DESIGN ENGINEER. SEE TECHNICAL NOTE 6.32 FOR MANIFOLD SIZING GUIDANCE.
- DUE TO THE ADAPTATION OF THIS CHAMBER SYSTEM TO SPECIFIC SITE AND DESIGN CONSTRAINTS, IT MAY BE NECESSARY TO CUT AND COUPLE ADDITIONAL PIPE TO STANDARD MANIFOLD COMPONENTS IN THE FIELD.
- THE SITE DESIGN ENGINEER MUST REVIEW ELEVATIONS AND IF NECESSARY ADJUST GRADING TO ENSURE THE CHAMBER COVER REQUIREMENTS ARE MET.
- THIS CHAMBER SYSTEM WAS DESIGNED WITHOUT SITE-SPECIFIC INFORMATION ON SOIL CONDITIONS OR BEARING CAPACITY. THE SITE DESIGN ENGINEER IS RESPONSIBLE FOR DETERMINING THE SUITABILITY OF THE SOIL AND PROVIDING THE BEARING CAPACITY OF THE INSITU SOILS. THE BASE STONE DEPTH MAY BE INCREASED OR DECREASED ONCE THIS INFORMATION IS PROVIDED..

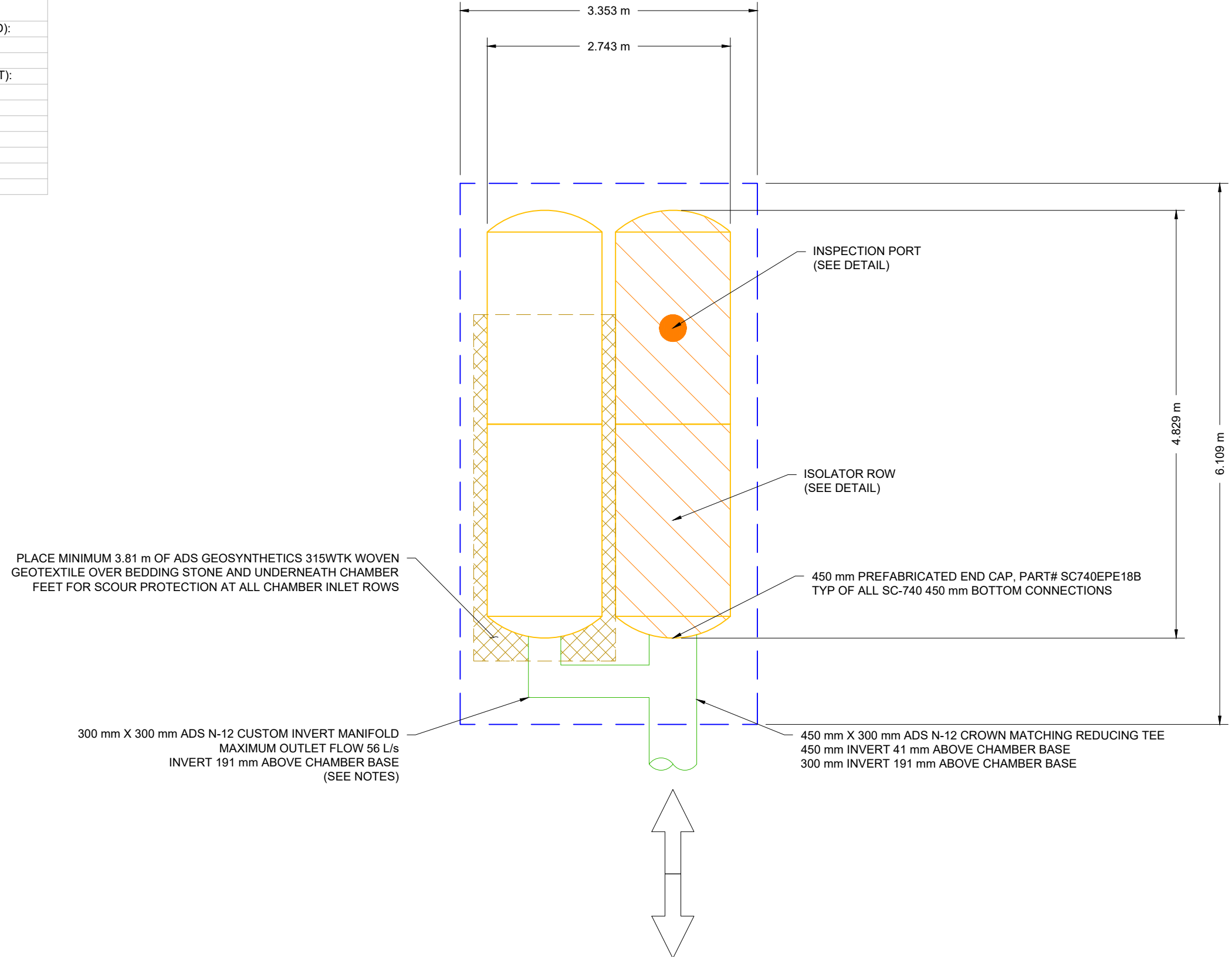

HARD ROCK OTTAWA	
OTTAWA, ON.	
DATE: 06/12/20	DRAWN: RCT
PROJECT #: S188516	CHECKED: JMQ

DATE	DRWN	CHKD	DESCRIPTION

**StormTech**  
 Retention • Retention • Water Quality  
 520 CROMWELL AVENUE | ROCKY HILL | CT | 06067  
 860-529-8188 | 888-892-2894 | WWW.STORMTECH.COM

**ADS**  
 ADVANCED DRAINAGE SYSTEMS, INC.  
 4640 TRUEMAN BLVD  
 HILLIARD, OH 43026

SCALE = 1 : 50

THIS DRAWING HAS BEEN PREPARED BASED ON INFORMATION PROVIDED TO ADS UNDER THE DIRECTION OF THE SITE DESIGN ENGINEER OR OTHER PROJECT REPRESENTATIVE. THE SITE DESIGN ENGINEER SHALL REVIEW THIS DRAWING PRIOR TO CONSTRUCTION. IT IS THE ULTIMATE RESPONSIBILITY OF THE SITE DESIGN ENGINEER TO ENSURE THAT THE PRODUCT(S) DEPICTED AND ALL ASSOCIATED DETAILS MEET ALL APPLICABLE LAWS, REGULATIONS, AND PROJECT REQUIREMENTS.

**PROPOSED LAYOUT - SYSTEM 8**

4	STORMTECH SC-740 CHAMBERS
2	STORMTECH SC-740 END CAPS
152	STONE ABOVE (mm)
300	STONE BELOW (mm)
40	% STONE VOID
<b>9.4</b>	<b>INSTALLED SYSTEM VOLUME (m³) ABOVE ELEVATION 111.900 (PERIMETER STONE INCLUDED)</b>
<b>2.7</b>	<b>INSTALLED SYSTEM VOLUME (m³) BELOW ELEVATION 111.900 (PERIMETER STONE INCLUDED)</b>
18.6	SYSTEM AREA (m²)
23.3	SYSTEM PERIMETER (m)

**PROPOSED ELEVATIONS - SYSTEM 8**

115.059	MAXIMUM ALLOWABLE GRADE (TOP OF PAVEMENT/UNPAVED):
113.231	MINIMUM ALLOWABLE GRADE (UNPAVED WITH TRAFFIC):
113.078	MINIMUM ALLOWABLE GRADE (UNPAVED NO TRAFFIC):
113.078	MINIMUM ALLOWABLE GRADE (BASE OF FLEXIBLE PAVEMENT):
113.078	MINIMUM ALLOWABLE GRADE (TOP OF RIGID PAVEMENT):
112.773	TOP OF STONE:
112.621	TOP OF SC-740 CHAMBER:
111.900	450 mm ISOLATOR ROW INVERT:
111.859	BOTTOM OF SC-740 CHAMBER:
111.559	BOTTOM OF STONE:

**NOTES**

- MANIFOLD SIZE TO BE DETERMINED BY SITE DESIGN ENGINEER. SEE TECHNICAL NOTE 6.32 FOR MANIFOLD SIZING GUIDANCE.
- DUE TO THE ADAPTATION OF THIS CHAMBER SYSTEM TO SPECIFIC SITE AND DESIGN CONSTRAINTS, IT MAY BE NECESSARY TO CUT AND COUPLE ADDITIONAL PIPE TO STANDARD MANIFOLD COMPONENTS IN THE FIELD.
- THE SITE DESIGN ENGINEER MUST REVIEW ELEVATIONS AND IF NECESSARY ADJUST GRADING TO ENSURE THE CHAMBER COVER REQUIREMENTS ARE MET.
- THIS CHAMBER SYSTEM WAS DESIGNED WITHOUT SITE-SPECIFIC INFORMATION ON SOIL CONDITIONS OR BEARING CAPACITY. THE SITE DESIGN ENGINEER IS RESPONSIBLE FOR DETERMINING THE SUITABILITY OF THE SOIL AND PROVIDING THE BEARING CAPACITY OF THE INSITU SOILS. THE BASE STONE DEPTH MAY BE INCREASED OR DECREASED ONCE THIS INFORMATION IS PROVIDED..

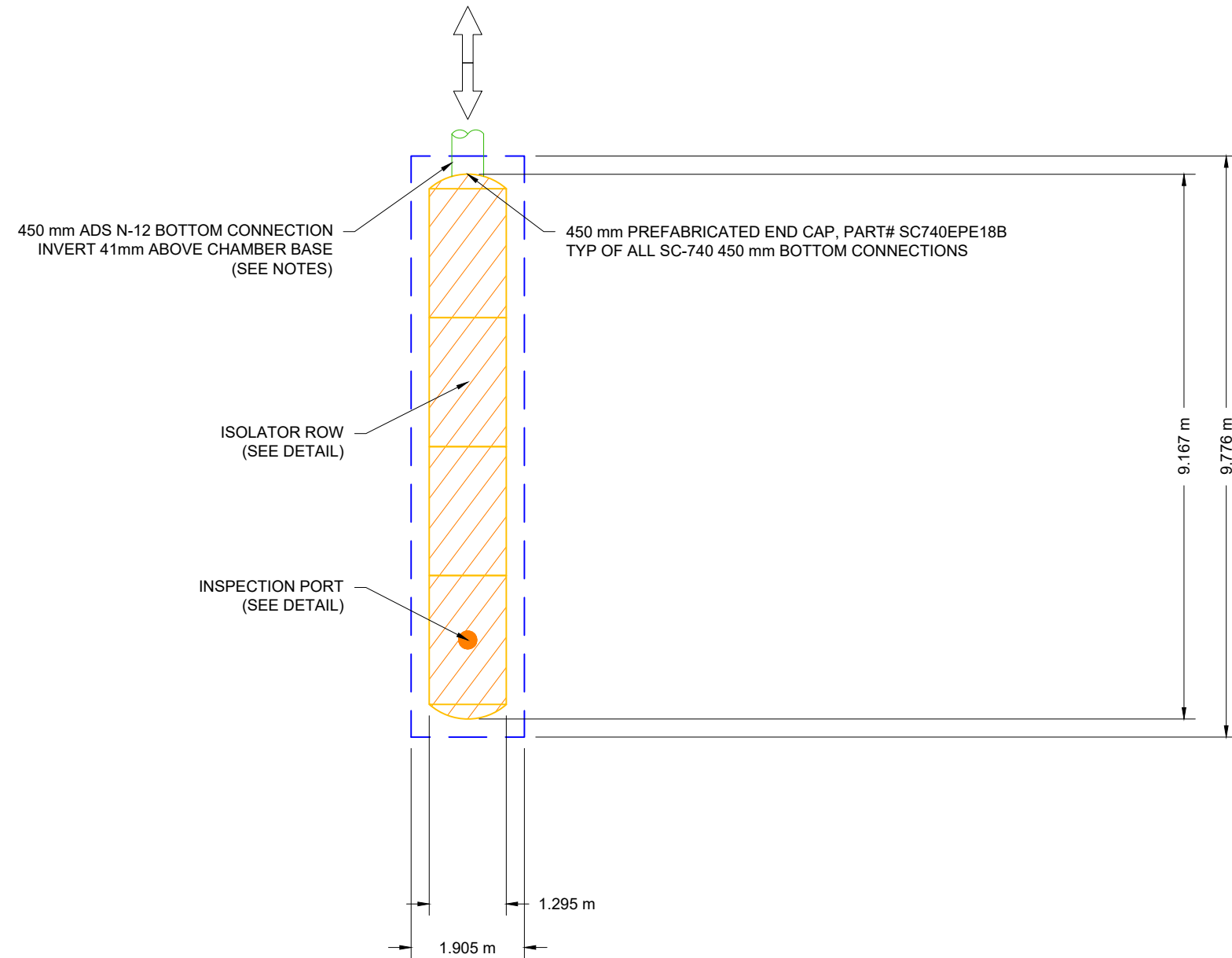

HARD ROCK OTTAWA	
OTTAWA, ON.	
DATE: 06/12/20	DRAWN: RCT
PROJECT #: S188516	CHECKED: JMQ

DATE	DRWN	CHKD	DESCRIPTION

**StormTech**  
 Retention • Retention • Water Quality  
 520 CROMWELL AVENUE | ROCKY HILL | CT | 06067  
 860-529-8188 | 888-892-2894 | WWW.STORMTECH.COM

**ADS**  
 ADVANCED DRAINAGE SYSTEMS, INC.  
 4640 TRUEMAN BLVD  
 HILLIARD, OH 43026  
**SCALE = 1 : 100**

THIS DRAWING HAS BEEN PREPARED BASED ON INFORMATION PROVIDED TO ADS UNDER THE DIRECTION OF THE SITE DESIGN ENGINEER OR OTHER PROJECT REPRESENTATIVE. THE SITE DESIGN ENGINEER SHALL REVIEW THIS DRAWING PRIOR TO CONSTRUCTION. IT IS THE ULTIMATE RESPONSIBILITY OF THE SITE DESIGN ENGINEER TO ENSURE THAT THE PRODUCT(S) DEPICTED AND ALL ASSOCIATED DETAILS MEET ALL APPLICABLE LAWS, REGULATIONS, AND PROJECT REQUIREMENTS.

**PROPOSED LAYOUT - SYSTEM 9**

50	STORMTECH SC-740 CHAMBERS
10	STORMTECH SC-740 END CAPS
152	STONE ABOVE (mm)
300	STONE BELOW (mm)
40	% STONE VOID
<b>107.1</b>	<b>INSTALLED SYSTEM VOLUME (m<sup>3</sup>) ABOVE ELEVATION 111.960 (PERIMETER STONE INCLUDED)</b>
<b>22.6</b>	<b>INSTALLED SYSTEM VOLUME (m<sup>3</sup>) BELOW ELEVATION 111.960 (PERIMETER STONE INCLUDED)</b>
186.0	SYSTEM AREA (m <sup>2</sup> )
63.1	SYSTEM PERIMETER (m)

**PROPOSED ELEVATIONS - SYSTEM 9**

115.157	MAXIMUM ALLOWABLE GRADE (TOP OF PAVEMENT/UNPAVED):
113.329	MINIMUM ALLOWABLE GRADE (UNPAVED WITH TRAFFIC):
113.176	MINIMUM ALLOWABLE GRADE (UNPAVED NO TRAFFIC):
113.176	MINIMUM ALLOWABLE GRADE (BASE OF FLEXIBLE PAVEMENT):
113.176	MINIMUM ALLOWABLE GRADE (TOP OF RIGID PAVEMENT):
112.871	TOP OF STONE:
112.719	TOP OF SC-740 CHAMBER:
112.275	300 mm TOP MANIFOLD INVERT:
111.960	600 mm ISOLATOR ROW INVERT:
111.957	BOTTOM OF SC-740 CHAMBER:
111.657	BOTTOM OF STONE:

**NOTES**

- MANIFOLD SIZE TO BE DETERMINED BY SITE DESIGN ENGINEER. SEE TECHNICAL NOTE 6.32 FOR MANIFOLD SIZING GUIDANCE.
- DUE TO THE ADAPTATION OF THIS CHAMBER SYSTEM TO SPECIFIC SITE AND DESIGN CONSTRAINTS, IT MAY BE NECESSARY TO CUT AND COUPLE ADDITIONAL PIPE TO STANDARD MANIFOLD COMPONENTS IN THE FIELD.
- THE SITE DESIGN ENGINEER MUST REVIEW ELEVATIONS AND IF NECESSARY ADJUST GRADING TO ENSURE THE CHAMBER COVER REQUIREMENTS ARE MET.
- THIS CHAMBER SYSTEM WAS DESIGNED WITHOUT SITE-SPECIFIC INFORMATION ON SOIL CONDITIONS OR BEARING CAPACITY. THE SITE DESIGN ENGINEER IS RESPONSIBLE FOR DETERMINING THE SUITABILITY OF THE SOIL AND PROVIDING THE BEARING CAPACITY OF THE INSITU SOILS. THE BASE STONE DEPTH MAY BE INCREASED OR DECREASED ONCE THIS INFORMATION IS PROVIDED..

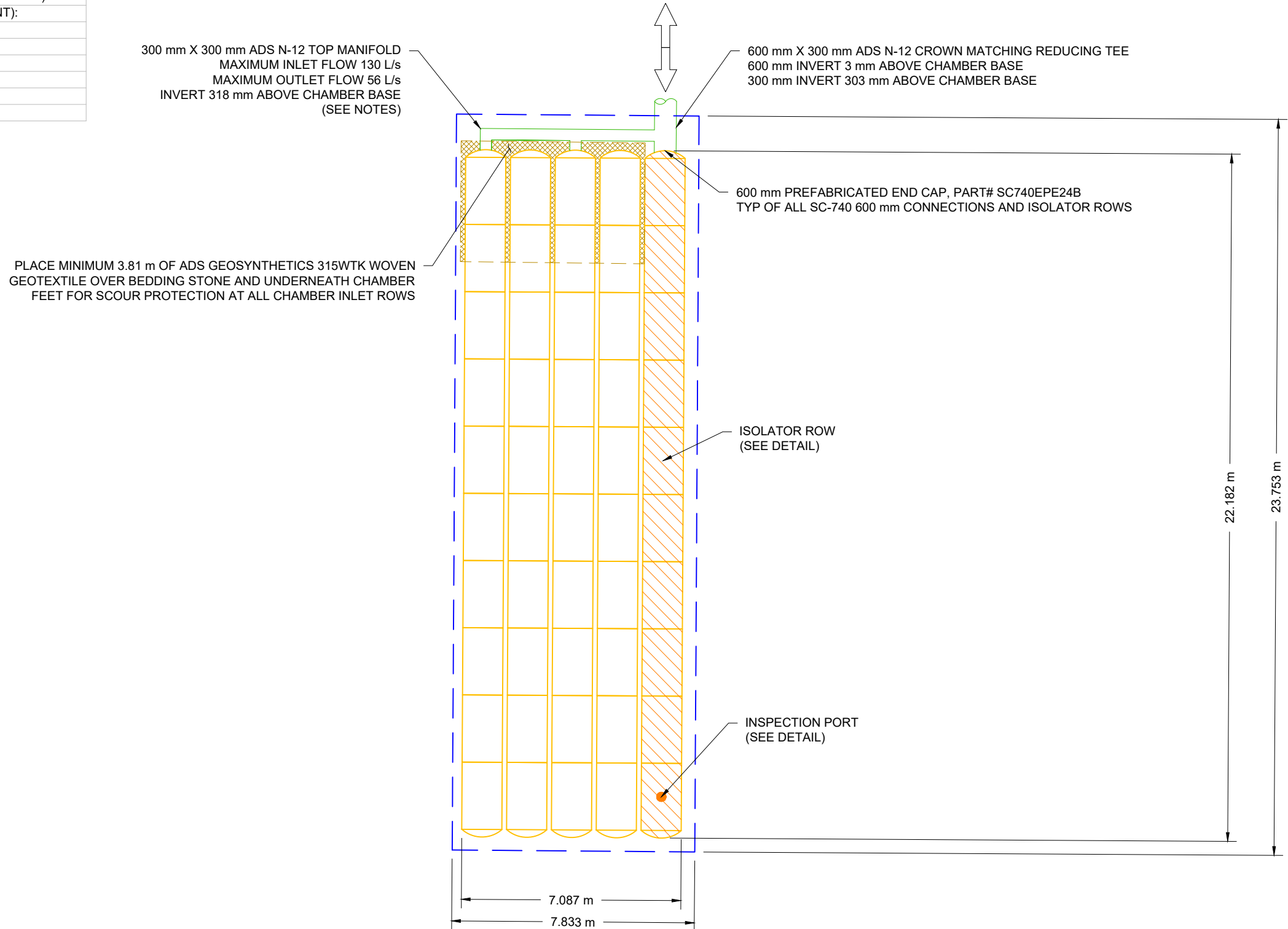

HARD ROCK OTTAWA	
OTTAWA, ON.	
DATE: 06/12/20	DRAWN: RCT
PROJECT #: S188516	CHECKED: JMQ

DATE	DRWN	CHKD	DESCRIPTION

**StormTech**  
Retention • Retention • Water Quality

520 CROMWELL AVENUE | ROCKY HILL | CT | 06067  
860-529-8188 | 888-892-2894 | WWW.STORMTECH.COM

**ADS**  
ADVANCED DRAINAGE SYSTEMS, INC.

4640 TRUEMAN BLVD  
HILLIARD, OH 43026

SCALE = 1 : 150

THIS DRAWING HAS BEEN PREPARED BASED ON INFORMATION PROVIDED TO ADS UNDER THE DIRECTION OF THE SITE DESIGN ENGINEER OR OTHER PROJECT REPRESENTATIVE. THE SITE DESIGN ENGINEER SHALL REVIEW THIS DRAWING PRIOR TO CONSTRUCTION. IT IS THE ULTIMATE RESPONSIBILITY OF THE SITE DESIGN ENGINEER TO ENSURE THAT THE PRODUCT(S) DEPICTED AND ALL ASSOCIATED DETAILS MEET ALL APPLICABLE LAWS, REGULATIONS, AND PROJECT REQUIREMENTS.

**PROPOSED LAYOUT - SYSTEM 10**

8	STORMTECH SC-740 CHAMBERS
4	STORMTECH SC-740 END CAPS
152	STONE ABOVE (mm)
300	STONE BELOW (mm)
40	% STONE VOID
<b>18.1</b>	<b>INSTALLED SYSTEM VOLUME (m³) ABOVE ELEVATION 111.850 (PERIMETER STONE INCLUDED)</b>
<b>5.2</b>	<b>INSTALLED SYSTEM VOLUME (m³) BELOW ELEVATION 111.850 (PERIMETER STONE INCLUDED)</b>
35.0	SYSTEM AREA (m²)
27.5	SYSTEM PERIMETER (m)

**PROPOSED ELEVATIONS - SYSTEM 10**

115.009	MAXIMUM ALLOWABLE GRADE (TOP OF PAVEMENT/UNPAVED):
113.181	MINIMUM ALLOWABLE GRADE (UNPAVED WITH TRAFFIC):
113.028	MINIMUM ALLOWABLE GRADE (UNPAVED NO TRAFFIC):
113.028	MINIMUM ALLOWABLE GRADE (BASE OF FLEXIBLE PAVEMENT):
113.028	MINIMUM ALLOWABLE GRADE (TOP OF RIGID PAVEMENT):
112.723	TOP OF STONE:
112.571	TOP OF SC-740 CHAMBER:
112.000	300 mm CUSTOM MANIFOLD INVERT:
111.850	450 mm ISOLATOR ROW INVERT:
111.809	BOTTOM OF SC-740 CHAMBER:
111.509	BOTTOM OF STONE:

**NOTES**

- MANIFOLD SIZE TO BE DETERMINED BY SITE DESIGN ENGINEER. SEE TECHNICAL NOTE 6.32 FOR MANIFOLD SIZING GUIDANCE.
- DUE TO THE ADAPTATION OF THIS CHAMBER SYSTEM TO SPECIFIC SITE AND DESIGN CONSTRAINTS, IT MAY BE NECESSARY TO CUT AND COUPLE ADDITIONAL PIPE TO STANDARD MANIFOLD COMPONENTS IN THE FIELD.
- THE SITE DESIGN ENGINEER MUST REVIEW ELEVATIONS AND IF NECESSARY ADJUST GRADING TO ENSURE THE CHAMBER COVER REQUIREMENTS ARE MET.
- THIS CHAMBER SYSTEM WAS DESIGNED WITHOUT SITE-SPECIFIC INFORMATION ON SOIL CONDITIONS OR BEARING CAPACITY. THE SITE DESIGN ENGINEER IS RESPONSIBLE FOR DETERMINING THE SUITABILITY OF THE SOIL AND PROVIDING THE BEARING CAPACITY OF THE INSITU SOILS. THE BASE STONE DEPTH MAY BE INCREASED OR DECREASED ONCE THIS INFORMATION IS PROVIDED..

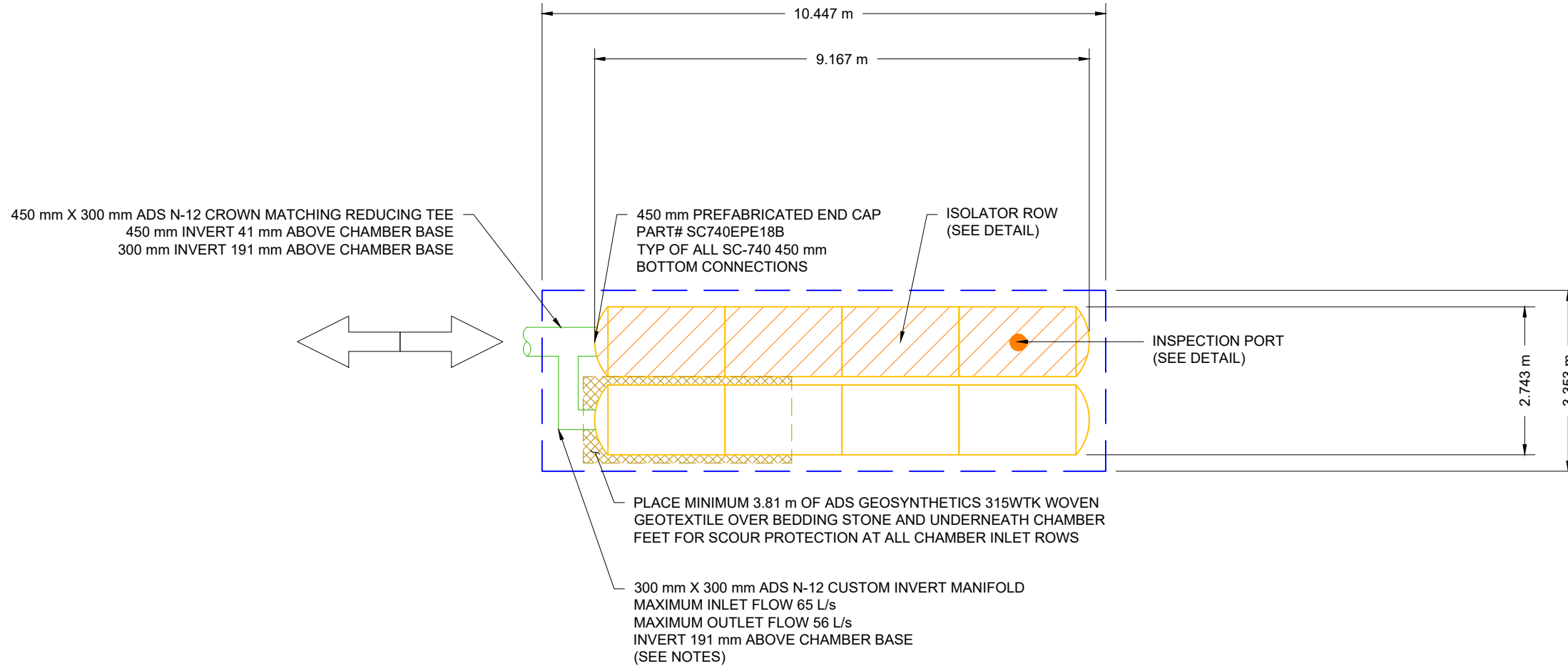

HARD ROCK OTTAWA	
OTTAWA, ON.	
DATE: 06/12/20	DRAWN: RCT
PROJECT #: S188516	CHECKED: JMQ

DATE	DRWN	CHKD	DESCRIPTION

**StormTech**  
Retention • Retention • Water Quality

520 CROMWELL AVENUE | ROCKY HILL | CT | 06067  
860-529-8188 | 888-892-2894 | WWW.STORMTECH.COM

**ADS**  
ADVANCED DRAINAGE SYSTEMS, INC.

4640 TRUEMAN BLVD  
HILLIARD, OH 43026

**SCALE = 1 : 100**

THIS DRAWING HAS BEEN PREPARED BASED ON INFORMATION PROVIDED TO ADS UNDER THE DIRECTION OF THE SITE DESIGN ENGINEER OR OTHER PROJECT REPRESENTATIVE. THE SITE DESIGN ENGINEER SHALL REVIEW THIS DRAWING PRIOR TO CONSTRUCTION. IT IS THE ULTIMATE RESPONSIBILITY OF THE SITE DESIGN ENGINEER TO ENSURE THAT THE PRODUCT(S) DEPICTED AND ALL ASSOCIATED DETAILS MEET ALL APPLICABLE LAWS, REGULATIONS, AND PROJECT REQUIREMENTS.



**PROPOSED LAYOUT - SYSTEM 11**

18	STORMTECH SC-740 CHAMBERS
6	STORMTECH SC-740 END CAPS
152	STONE ABOVE (mm)
300	STONE BELOW (mm)
40	% STONE VOID
<b>40.2</b>	<b>INSTALLED SYSTEM VOLUME (m<sup>3</sup>) ABOVE ELEVATION 112.04 (PERIMETER STONE INCLUDED)</b>
<b>8.7</b>	<b>INSTALLED SYSTEM VOLUME (m<sup>3</sup>) BELOW ELEVATION 112.04 (PERIMETER STONE INCLUDED)</b>
71.5	SYSTEM AREA (m <sup>2</sup> )
39.2	SYSTEM PERIMETER (m)

**PROPOSED ELEVATIONS - SYSTEM 11**

115.237	MAXIMUM ALLOWABLE GRADE (TOP OF PAVEMENT/UNPAVED):
113.409	MINIMUM ALLOWABLE GRADE (UNPAVED WITH TRAFFIC):
113.256	MINIMUM ALLOWABLE GRADE (UNPAVED NO TRAFFIC):
113.256	MINIMUM ALLOWABLE GRADE (BASE OF FLEXIBLE PAVEMENT):
113.256	MINIMUM ALLOWABLE GRADE (TOP OF RIGID PAVEMENT):
112.951	TOP OF STONE:
112.799	TOP OF SC-740 CHAMBER:
112.355	300 mm TOP MANIFOLD INVERT:
112.040	600 mm ISOLATOR ROW INVERT:
112.037	BOTTOM OF SC-740 CHAMBER:
111.737	BOTTOM OF STONE:

**NOTES**

- MANIFOLD SIZE TO BE DETERMINED BY SITE DESIGN ENGINEER. SEE TECHNICAL NOTE 6.32 FOR MANIFOLD SIZING GUIDANCE.
- DUE TO THE ADAPTATION OF THIS CHAMBER SYSTEM TO SPECIFIC SITE AND DESIGN CONSTRAINTS, IT MAY BE NECESSARY TO CUT AND COUPLE ADDITIONAL PIPE TO STANDARD MANIFOLD COMPONENTS IN THE FIELD.
- THE SITE DESIGN ENGINEER MUST REVIEW ELEVATIONS AND IF NECESSARY ADJUST GRADING TO ENSURE THE CHAMBER COVER REQUIREMENTS ARE MET.
- THIS CHAMBER SYSTEM WAS DESIGNED WITHOUT SITE-SPECIFIC INFORMATION ON SOIL CONDITIONS OR BEARING CAPACITY. THE SITE DESIGN ENGINEER IS RESPONSIBLE FOR DETERMINING THE SUITABILITY OF THE SOIL AND PROVIDING THE BEARING CAPACITY OF THE INSITU SOILS. THE BASE STONE DEPTH MAY BE INCREASED OR DECREASED ONCE THIS INFORMATION IS PROVIDED..

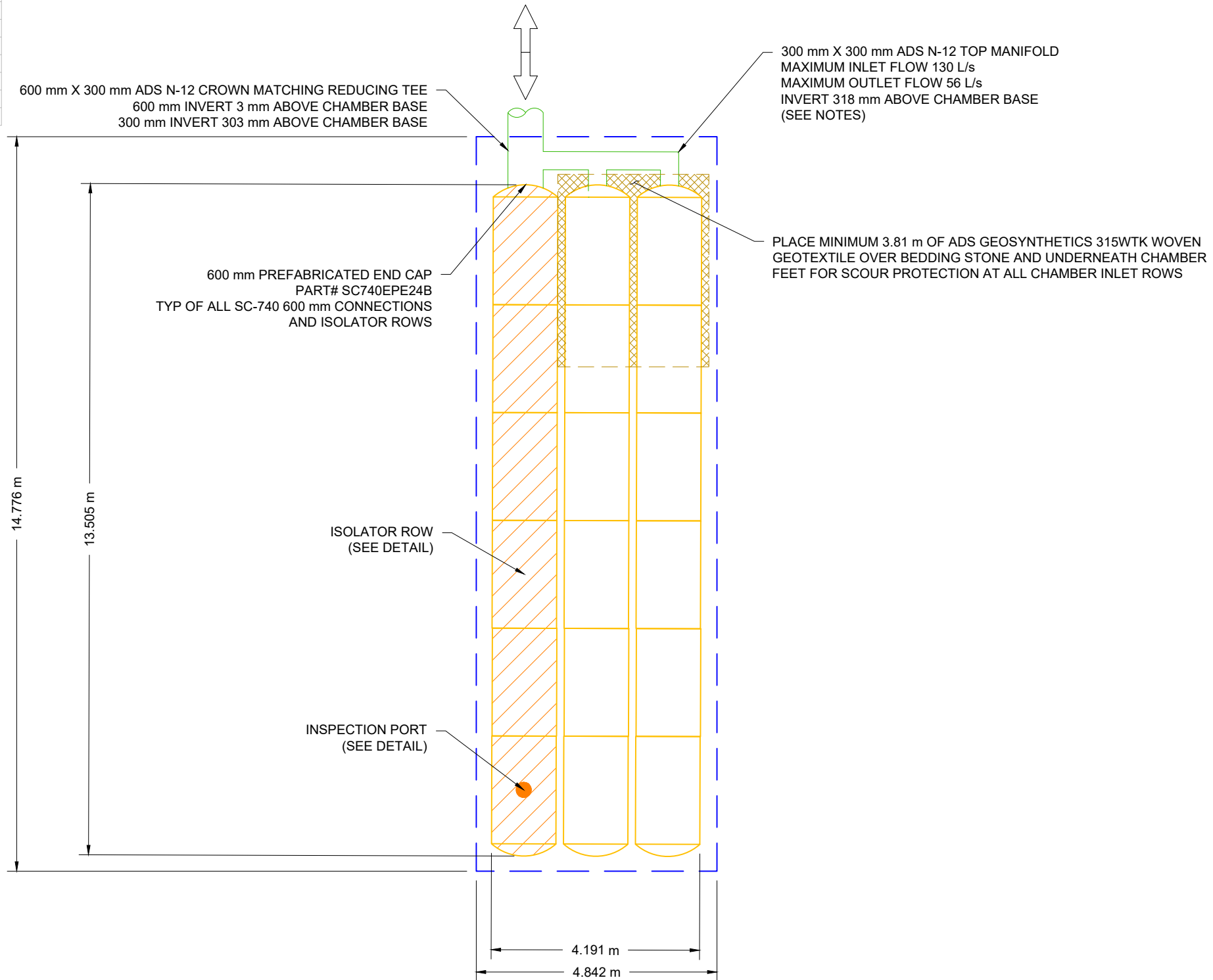

HARD ROCK OTTAWA	
OTTAWA, ON.	
DATE: 06/12/20	DRAWN: RCT
PROJECT #: S188516	CHECKED: JMQ

DATE	DRWN	CHKD	DESCRIPTION

**StormTech**  
 Attention • Retention • Water Quality  
 520 CROMWELL AVENUE | ROCKY HILL | CT | 06067  
 860-529-8188 | 888-892-2894 | WWW.STORMTECH.COM

**ADS**  
 ADVANCED DRAINAGE SYSTEMS, INC.  
 4640 TRUEMAN BLVD  
 HILLIARD, OH 43026

SCALE = 1 : 100

THIS DRAWING HAS BEEN PREPARED BASED ON INFORMATION PROVIDED TO ADS UNDER THE DIRECTION OF THE SITE DESIGN ENGINEER OR OTHER PROJECT REPRESENTATIVE. THE SITE DESIGN ENGINEER SHALL REVIEW THIS DRAWING PRIOR TO CONSTRUCTION. IT IS THE ULTIMATE RESPONSIBILITY OF THE SITE DESIGN ENGINEER TO ENSURE THAT THE PRODUCT(S) DEPICTED AND ALL ASSOCIATED DETAILS MEET ALL APPLICABLE LAWS, REGULATIONS, AND PROJECT REQUIREMENTS.

**PROPOSED LAYOUT - SYSTEM 12**

6	STORMTECH SC-740 CHAMBERS
4	STORMTECH SC-740 END CAPS
152	STONE ABOVE (mm)
300	STONE BELOW (mm)
40	% STONE VOID
<b>14.8</b>	<b>INSTALLED SYSTEM VOLUME (m<sup>3</sup>) ABOVE ELEVATION 111.830 (PERIMETER STONE INCLUDED)</b>
<b>3.3</b>	<b>INSTALLED SYSTEM VOLUME (m<sup>3</sup>) BELOW ELEVATION 111.830 (PERIMETER STONE INCLUDED)</b>
27.7	SYSTEM AREA (m <sup>2</sup> )
23.2	SYSTEM PERIMETER (m)

**PROPOSED ELEVATIONS - SYSTEM 12**

115.027	MAXIMUM ALLOWABLE GRADE (TOP OF PAVEMENT/UNPAVED):
113.199	MINIMUM ALLOWABLE GRADE (UNPAVED WITH TRAFFIC):
113.046	MINIMUM ALLOWABLE GRADE (UNPAVED NO TRAFFIC):
113.046	MINIMUM ALLOWABLE GRADE (BASE OF FLEXIBLE PAVEMENT):
113.046	MINIMUM ALLOWABLE GRADE (TOP OF RIGID PAVEMENT):
112.741	TOP OF STONE:
112.589	TOP OF SC-740 CHAMBER:
112.145	300 mm TOP MANIFOLD INVERT:
111.830	600 mm ISOLATOR ROW INVERT:
111.827	BOTTOM OF SC-740 CHAMBER:
111.527	BOTTOM OF STONE:

**NOTES**

- MANIFOLD SIZE TO BE DETERMINED BY SITE DESIGN ENGINEER. SEE TECHNICAL NOTE 6.32 FOR MANIFOLD SIZING GUIDANCE.
- DUE TO THE ADAPTATION OF THIS CHAMBER SYSTEM TO SPECIFIC SITE AND DESIGN CONSTRAINTS, IT MAY BE NECESSARY TO CUT AND COUPLE ADDITIONAL PIPE TO STANDARD MANIFOLD COMPONENTS IN THE FIELD.
- THE SITE DESIGN ENGINEER MUST REVIEW ELEVATIONS AND IF NECESSARY ADJUST GRADING TO ENSURE THE CHAMBER COVER REQUIREMENTS ARE MET.
- THIS CHAMBER SYSTEM WAS DESIGNED WITHOUT SITE-SPECIFIC INFORMATION ON SOIL CONDITIONS OR BEARING CAPACITY. THE SITE DESIGN ENGINEER IS RESPONSIBLE FOR DETERMINING THE SUITABILITY OF THE SOIL AND PROVIDING THE BEARING CAPACITY OF THE INSITU SOILS. THE BASE STONE DEPTH MAY BE INCREASED OR DECREASED ONCE THIS INFORMATION IS PROVIDED..

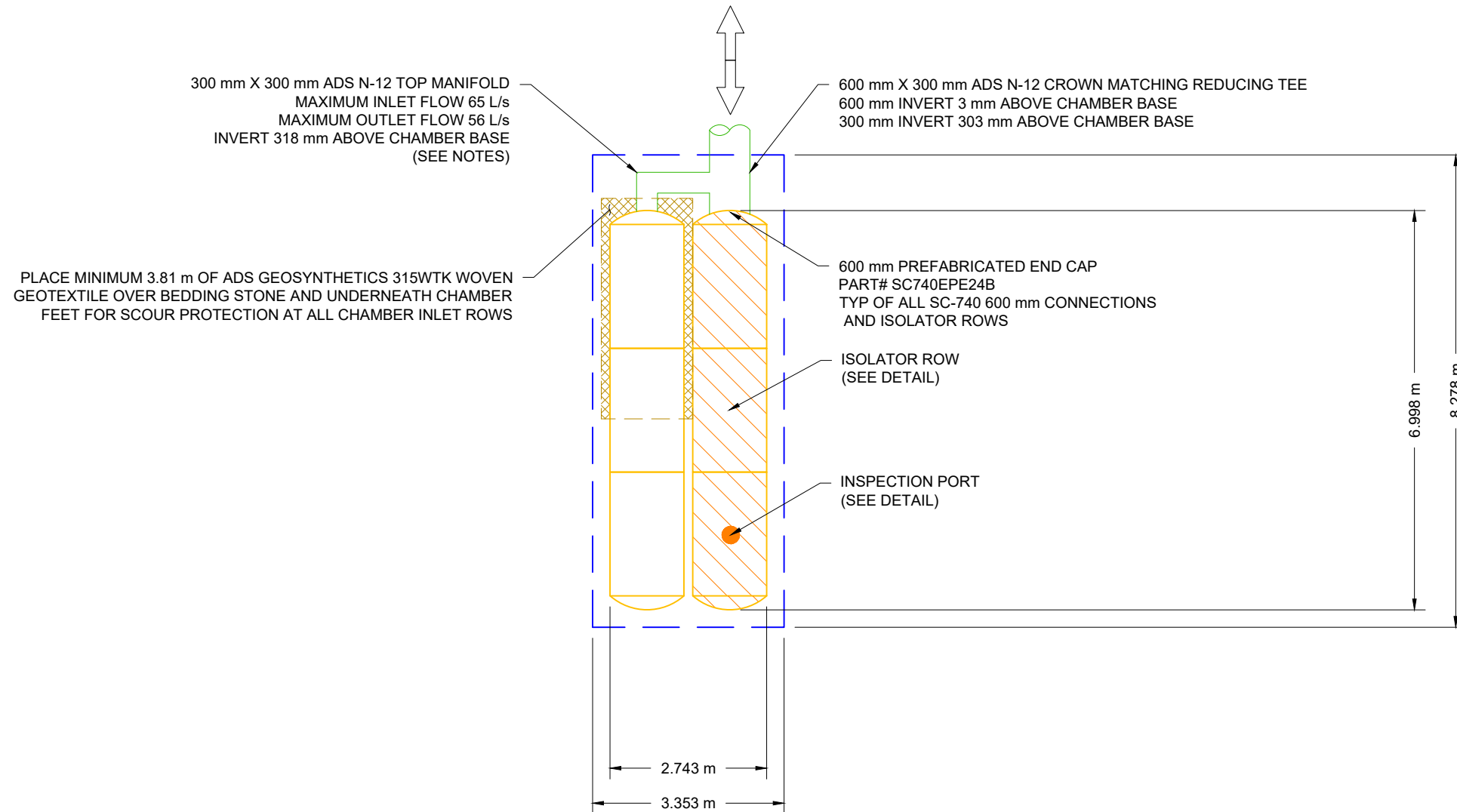

HARD ROCK OTTAWA	
OTTAWA, ON.	
DATE: 06/12/20	DRAWN: RCT
PROJECT #: S188516	CHECKED: JMQ

DATE	DRWN	CHKD	DESCRIPTION

**StormTech**  
Retention • Retention • Water Quality  
 520 CROMWELL AVENUE | ROCKY HILL | CT | 06067  
 860-529-8188 | 888-892-2894 | WWW.STORMTECH.COM

**ADS**  
ADVANCED DRAINAGE SYSTEMS, INC.  
 4640 TRUEMAN BLVD  
 HILLIARD, OH 43026

**SCALE = 1 : 100**

THIS DRAWING HAS BEEN PREPARED BASED ON INFORMATION PROVIDED TO ADS UNDER THE DIRECTION OF THE SITE DESIGN ENGINEER OR OTHER PROJECT REPRESENTATIVE. THE SITE DESIGN ENGINEER SHALL REVIEW THIS DRAWING PRIOR TO CONSTRUCTION. IT IS THE ULTIMATE RESPONSIBILITY OF THE SITE DESIGN ENGINEER TO ENSURE THAT THE PRODUCT(S) DEPICTED AND ALL ASSOCIATED DETAILS MEET ALL APPLICABLE LAWS, REGULATIONS, AND PROJECT REQUIREMENTS.

**PROPOSED LAYOUT - SYSTEM 13**

16	STORMTECH SC-740 CHAMBERS
8	STORMTECH SC-740 END CAPS
152	STONE ABOVE (mm)
300	STONE BELOW (mm)
40	% STONE VOID
<b>36.3</b>	<b>INSTALLED SYSTEM VOLUME (m<sup>3</sup>) ABOVE ELEVATION 112.04 (PERIMETER STONE INCLUDED)</b>
<b>7.9</b>	<b>INSTALLED SYSTEM VOLUME (m<sup>3</sup>) BELOW ELEVATION 112.04 (PERIMETER STONE INCLUDED)</b>
65.3	SYSTEM AREA (m <sup>2</sup> )
33.4	SYSTEM PERIMETER (m)

**PROPOSED ELEVATIONS - SYSTEM 13**

115.237	MAXIMUM ALLOWABLE GRADE (TOP OF PAVEMENT/UNPAVED):
113.409	MINIMUM ALLOWABLE GRADE (UNPAVED WITH TRAFFIC):
113.256	MINIMUM ALLOWABLE GRADE (UNPAVED NO TRAFFIC):
113.256	MINIMUM ALLOWABLE GRADE (BASE OF FLEXIBLE PAVEMENT):
113.256	MINIMUM ALLOWABLE GRADE (TOP OF RIGID PAVEMENT):
112.951	TOP OF STONE:
112.799	TOP OF SC-740 CHAMBER:
112.355	300 mm TOP MANIFOLD INVERT:
112.040	600 mm ISOLATOR ROW INVERT:
112.037	BOTTOM OF SC-740 CHAMBER:
111.737	BOTTOM OF STONE:

**NOTES**

- MANIFOLD SIZE TO BE DETERMINED BY SITE DESIGN ENGINEER. SEE TECHNICAL NOTE 6.32 FOR MANIFOLD SIZING GUIDANCE.
- DUE TO THE ADAPTATION OF THIS CHAMBER SYSTEM TO SPECIFIC SITE AND DESIGN CONSTRAINTS, IT MAY BE NECESSARY TO CUT AND COUPLE ADDITIONAL PIPE TO STANDARD MANIFOLD COMPONENTS IN THE FIELD.
- THE SITE DESIGN ENGINEER MUST REVIEW ELEVATIONS AND IF NECESSARY ADJUST GRADING TO ENSURE THE CHAMBER COVER REQUIREMENTS ARE MET.
- THIS CHAMBER SYSTEM WAS DESIGNED WITHOUT SITE-SPECIFIC INFORMATION ON SOIL CONDITIONS OR BEARING CAPACITY. THE SITE DESIGN ENGINEER IS RESPONSIBLE FOR DETERMINING THE SUITABILITY OF THE SOIL AND PROVIDING THE BEARING CAPACITY OF THE INSITU SOILS. THE BASE STONE DEPTH MAY BE INCREASED OR DECREASED ONCE THIS INFORMATION IS PROVIDED..

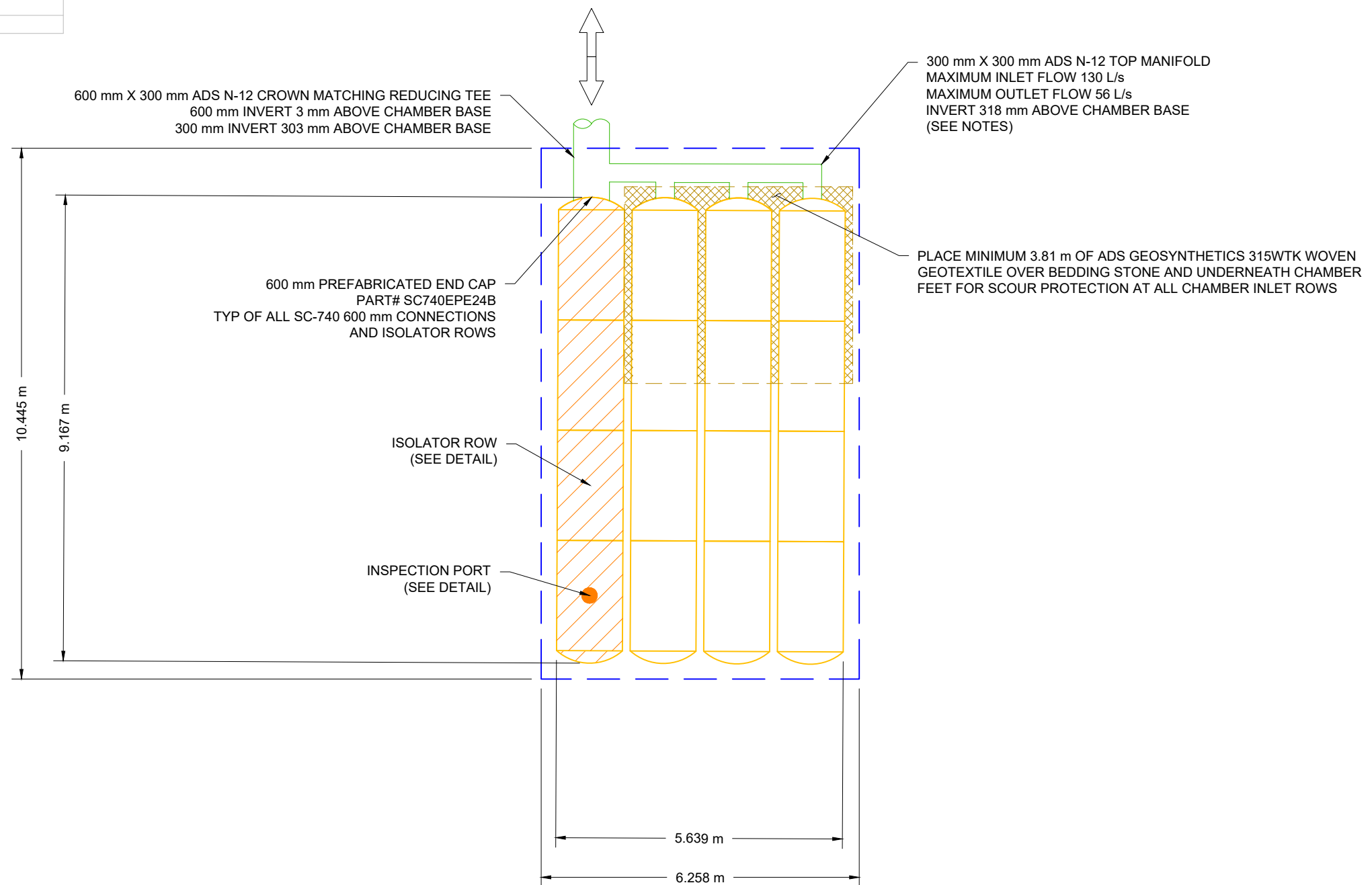

HARD ROCK OTTAWA	
OTTAWA, ON.	
DATE: 06/12/20	DRAWN: RCT
PROJECT #: S188516	CHECKED: JMQ

DATE	DRWN	CHKD	DESCRIPTION

**StormTech**  
Retention • Retention • Water Quality

520 CROMWELL AVENUE | ROCKY HILL | CT | 06067  
860-529-8188 | 888-892-2894 | WWW.STORMTECH.COM

**ADS**  
ADVANCED DRAINAGE SYSTEMS, INC.

4640 TRUEMAN BLVD  
HILLIARD, OH 43026

SCALE = 1 : 100

THIS DRAWING HAS BEEN PREPARED BASED ON INFORMATION PROVIDED TO ADS UNDER THE DIRECTION OF THE SITE DESIGN ENGINEER OR OTHER PROJECT REPRESENTATIVE. THE SITE DESIGN ENGINEER SHALL REVIEW THIS DRAWING PRIOR TO CONSTRUCTION. IT IS THE ULTIMATE RESPONSIBILITY OF THE SITE DESIGN ENGINEER TO ENSURE THAT THE PRODUCT(S) DEPICTED AND ALL ASSOCIATED DETAILS MEET ALL APPLICABLE LAWS, REGULATIONS, AND PROJECT REQUIREMENTS.

**PROPOSED LAYOUT - SYSTEM 14**

10	STORMTECH SC-740 CHAMBERS
4	STORMTECH SC-740 END CAPS
152	STONE ABOVE (mm)
300	STONE BELOW (mm)
40	% STONE VOID
<b>24.0</b>	<b>INSTALLED SYSTEM VOLUME (m³) ABOVE ELEVATION 111.850 (PERIMETER STONE INCLUDED)</b>
<b>4.8</b>	<b>INSTALLED SYSTEM VOLUME (m³) BELOW ELEVATION 111.850 (PERIMETER STONE INCLUDED)</b>
43.2	SYSTEM AREA (m²)
32.1	SYSTEM PERIMETER (m)

**PROPOSED ELEVATIONS - SYSTEM 14**

115.047	MAXIMUM ALLOWABLE GRADE (TOP OF PAVEMENT/UNPAVED):
113.219	MINIMUM ALLOWABLE GRADE (UNPAVED WITH TRAFFIC):
113.066	MINIMUM ALLOWABLE GRADE (UNPAVED NO TRAFFIC):
113.066	MINIMUM ALLOWABLE GRADE (BASE OF FLEXIBLE PAVEMENT):
113.066	MINIMUM ALLOWABLE GRADE (TOP OF RIGID PAVEMENT):
112.761	TOP OF STONE:
112.609	TOP OF SC-740 CHAMBER:
112.165	300 mm TOP MANIFOLD INVERT:
111.850	600 mm ISOLATOR ROW INVERT:
111.847	BOTTOM OF SC-740 CHAMBER:
111.547	BOTTOM OF STONE:

**NOTES**

- MANIFOLD SIZE TO BE DETERMINED BY SITE DESIGN ENGINEER. SEE TECHNICAL NOTE 6.32 FOR MANIFOLD SIZING GUIDANCE.
- DUE TO THE ADAPTATION OF THIS CHAMBER SYSTEM TO SPECIFIC SITE AND DESIGN CONSTRAINTS, IT MAY BE NECESSARY TO CUT AND COUPLE ADDITIONAL PIPE TO STANDARD MANIFOLD COMPONENTS IN THE FIELD.
- THE SITE DESIGN ENGINEER MUST REVIEW ELEVATIONS AND IF NECESSARY ADJUST GRADING TO ENSURE THE CHAMBER COVER REQUIREMENTS ARE MET.
- THIS CHAMBER SYSTEM WAS DESIGNED WITHOUT SITE-SPECIFIC INFORMATION ON SOIL CONDITIONS OR BEARING CAPACITY. THE SITE DESIGN ENGINEER IS RESPONSIBLE FOR DETERMINING THE SUITABILITY OF THE SOIL AND PROVIDING THE BEARING CAPACITY OF THE INSITU SOILS. THE BASE STONE DEPTH MAY BE INCREASED OR DECREASED ONCE THIS INFORMATION IS PROVIDED..

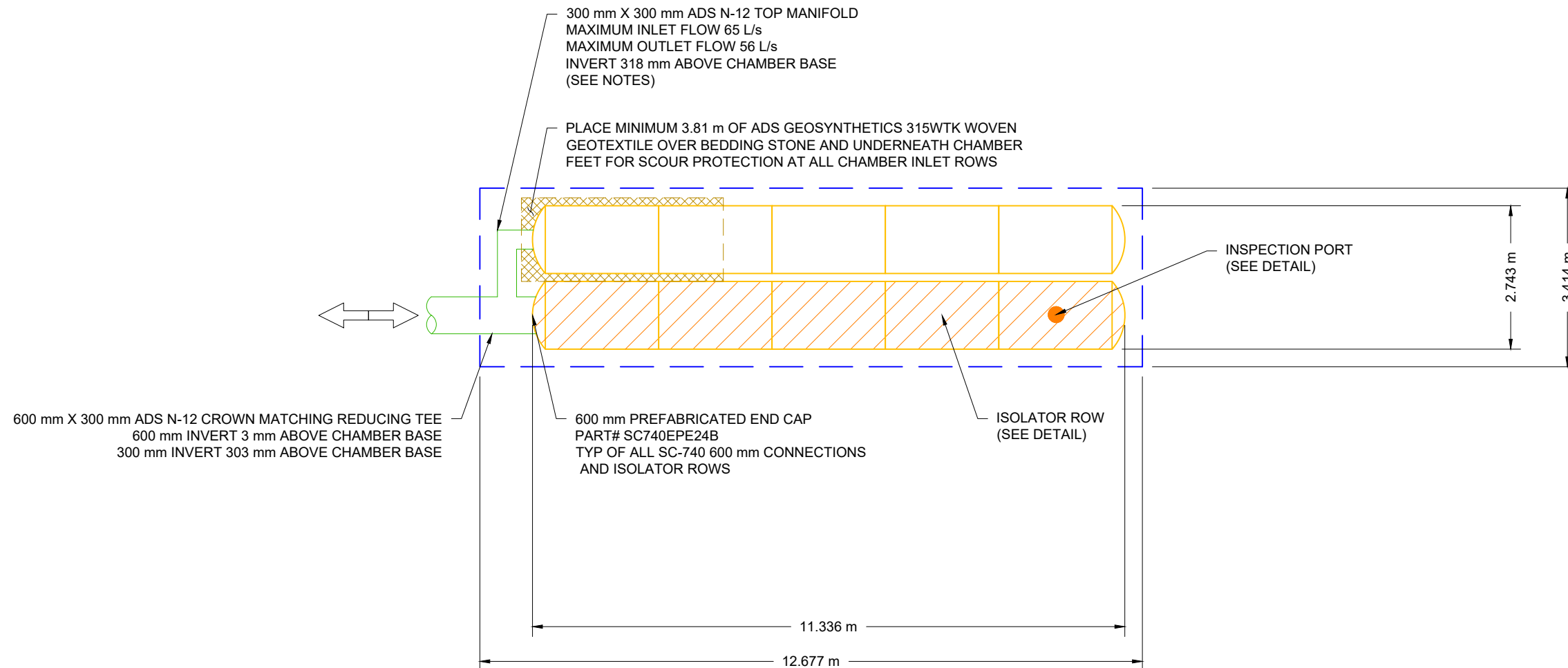

HARD ROCK OTTAWA	
OTTAWA, ON.	
DATE: 06/12/20	DRAWN: RCT
PROJECT #: S188516	CHECKED: JMQ

DATE	DRWN	CHKD	DESCRIPTION

**StormTech**  
Retention • Retention • Water Quality

520 CROMWELL AVENUE | ROCKY HILL | CT | 06067  
860-529-8188 | 888-892-2894 | WWW.STORMTECH.COM

**ADS**  
ADVANCED DRAINAGE SYSTEMS, INC.

4640 TRUEMAN BLVD  
HILLIARD, OH 43026

**SCALE = 1 : 100**

THIS DRAWING HAS BEEN PREPARED BASED ON INFORMATION PROVIDED TO ADS UNDER THE DIRECTION OF THE SITE DESIGN ENGINEER OR OTHER PROJECT REPRESENTATIVE. THE SITE DESIGN ENGINEER SHALL REVIEW THIS DRAWING PRIOR TO CONSTRUCTION. IT IS THE ULTIMATE RESPONSIBILITY OF THE SITE DESIGN ENGINEER TO ENSURE THAT THE PRODUCT(S) DEPICTED AND ALL ASSOCIATED DETAILS MEET ALL APPLICABLE LAWS, REGULATIONS, AND PROJECT REQUIREMENTS.

**PROPOSED LAYOUT - SYSTEM 15**

8	STORMTECH SC-740 CHAMBERS
4	STORMTECH SC-740 END CAPS
152	STONE ABOVE (mm)
300	STONE BELOW (mm)
40	% STONE VOID
<b>19.2</b>	<b>INSTALLED SYSTEM VOLUME (m³) ABOVE ELEVATION 112.030 (PERIMETER STONE INCLUDED)</b>
<b>4.2</b>	<b>INSTALLED SYSTEM VOLUME (m³) BELOW ELEVATION 112.030 (PERIMETER STONE INCLUDED)</b>
35.2	SYSTEM AREA (m²)
27.6	SYSTEM PERIMETER (m)

**PROPOSED ELEVATIONS - SYSTEM 15**

115.227	MAXIMUM ALLOWABLE GRADE (TOP OF PAVEMENT/UNPAVED):
113.399	MINIMUM ALLOWABLE GRADE (UNPAVED WITH TRAFFIC):
113.246	MINIMUM ALLOWABLE GRADE (UNPAVED NO TRAFFIC):
113.246	MINIMUM ALLOWABLE GRADE (BASE OF FLEXIBLE PAVEMENT):
113.246	MINIMUM ALLOWABLE GRADE (TOP OF RIGID PAVEMENT):
112.941	TOP OF STONE:
112.789	TOP OF SC-740 CHAMBER:
112.345	300 mm TOP MANIFOLD INVERT:
112.030	600 mm ISOLATOR ROW INVERT:
112.027	BOTTOM OF SC-740 CHAMBER:
111.727	BOTTOM OF STONE:

**NOTES**

- MANIFOLD SIZE TO BE DETERMINED BY SITE DESIGN ENGINEER. SEE TECHNICAL NOTE 6.32 FOR MANIFOLD SIZING GUIDANCE.
- DUE TO THE ADAPTATION OF THIS CHAMBER SYSTEM TO SPECIFIC SITE AND DESIGN CONSTRAINTS, IT MAY BE NECESSARY TO CUT AND COUPLE ADDITIONAL PIPE TO STANDARD MANIFOLD COMPONENTS IN THE FIELD.
- THE SITE DESIGN ENGINEER MUST REVIEW ELEVATIONS AND IF NECESSARY ADJUST GRADING TO ENSURE THE CHAMBER COVER REQUIREMENTS ARE MET.
- THIS CHAMBER SYSTEM WAS DESIGNED WITHOUT SITE-SPECIFIC INFORMATION ON SOIL CONDITIONS OR BEARING CAPACITY. THE SITE DESIGN ENGINEER IS RESPONSIBLE FOR DETERMINING THE SUITABILITY OF THE SOIL AND PROVIDING THE BEARING CAPACITY OF THE INSITU SOILS. THE BASE STONE DEPTH MAY BE INCREASED OR DECREASED ONCE THIS INFORMATION IS PROVIDED..

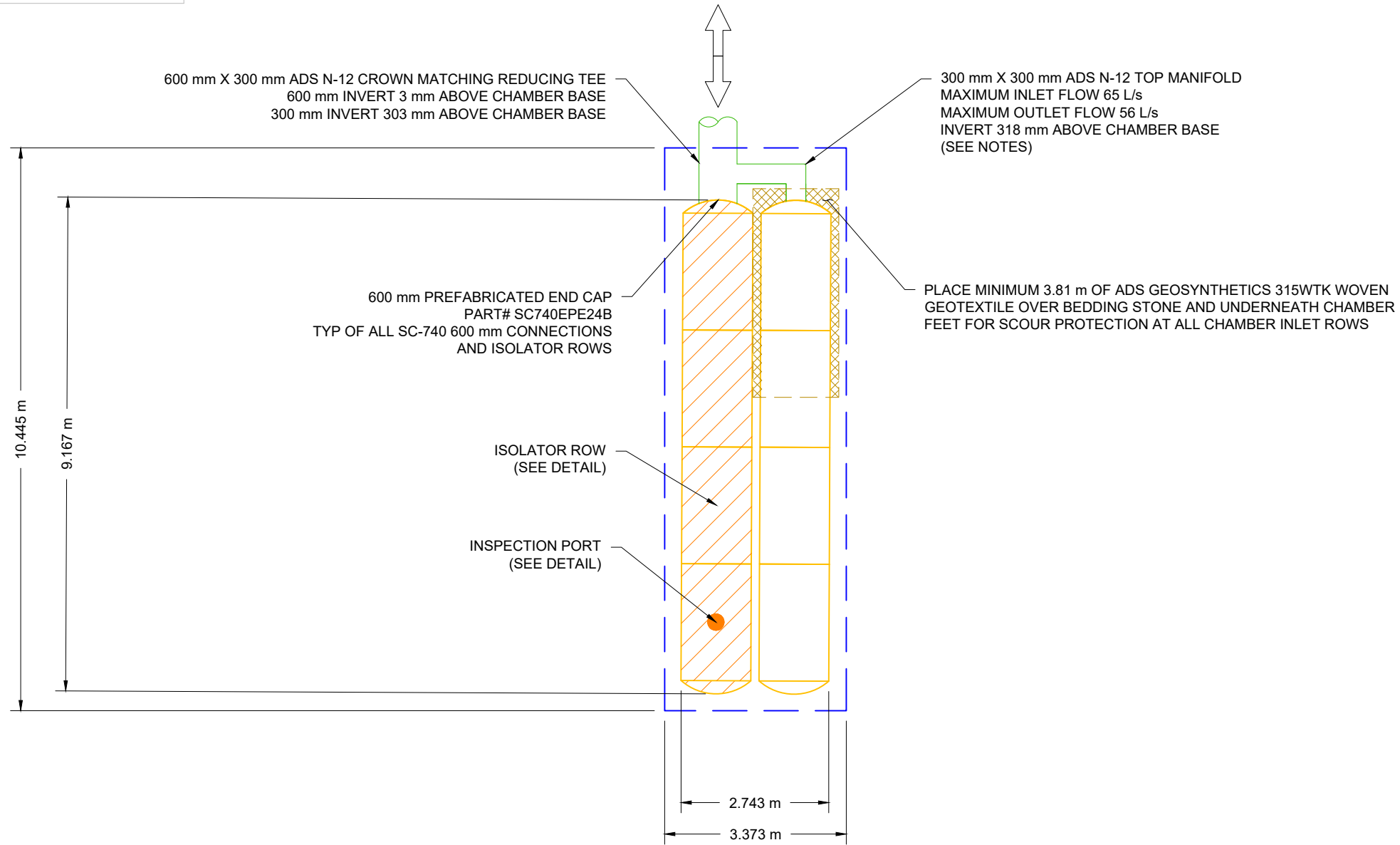

HARD ROCK OTTAWA	
OTTAWA, ON.	
DATE: 06/12/20	DRAWN: RCT
PROJECT #: S188516	CHECKED: JMQ

DATE	DRWN	CHKD	DESCRIPTION

**StormTech**  
Retention • Retention • Water Quality

520 CROMWELL AVENUE | ROCKY HILL | CT | 06067  
 860-529-8188 | 888-892-2894 | WWW.STORMTECH.COM

**ADS**  
ADVANCED DRAINAGE SYSTEMS, INC.

4640 TRUEMAN BLVD  
 HILLIARD, OH 43026

**SCALE = 1 : 100**

THIS DRAWING HAS BEEN PREPARED BASED ON INFORMATION PROVIDED TO ADS UNDER THE DIRECTION OF THE SITE DESIGN ENGINEER OR OTHER PROJECT REPRESENTATIVE. THE SITE DESIGN ENGINEER SHALL REVIEW THIS DRAWING PRIOR TO CONSTRUCTION. IT IS THE ULTIMATE RESPONSIBILITY OF THE SITE DESIGN ENGINEER TO ENSURE THAT THE PRODUCT(S) DEPICTED AND ALL ASSOCIATED DETAILS MEET ALL APPLICABLE LAWS, REGULATIONS, AND PROJECT REQUIREMENTS.

**PROPOSED LAYOUT - SYSTEM 16**

3	STORMTECH SC-740 CHAMBERS
2	STORMTECH SC-740 END CAPS
152	STONE ABOVE (mm)
300	STONE BELOW (mm)
40	% STONE VOID
<b>8.6</b>	<b>INSTALLED SYSTEM VOLUME (m³) ABOVE ELEVATION 111.850 (PERIMETER STONE INCLUDED)</b>
<b>2.6</b>	<b>INSTALLED SYSTEM VOLUME (m³) BELOW ELEVATION 111.850 (PERIMETER STONE INCLUDED)</b>
18.2	SYSTEM AREA (m²)
20.5	SYSTEM PERIMETER (m)

**PROPOSED ELEVATIONS - SYSTEM 16**

115.009	MAXIMUM ALLOWABLE GRADE (TOP OF PAVEMENT/UNPAVED):
113.181	MINIMUM ALLOWABLE GRADE (UNPAVED WITH TRAFFIC):
113.028	MINIMUM ALLOWABLE GRADE (UNPAVED NO TRAFFIC):
113.028	MINIMUM ALLOWABLE GRADE (BASE OF FLEXIBLE PAVEMENT):
113.028	MINIMUM ALLOWABLE GRADE (TOP OF RIGID PAVEMENT):
112.723	TOP OF STONE:
112.571	TOP OF SC-740 CHAMBER:
111.850	450 mm ISOLATOR ROW INVERT:
111.809	BOTTOM OF SC-740 CHAMBER:
111.509	BOTTOM OF STONE:

**NOTES**

- MANIFOLD SIZE TO BE DETERMINED BY SITE DESIGN ENGINEER. SEE TECHNICAL NOTE 6.32 FOR MANIFOLD SIZING GUIDANCE.
- DUE TO THE ADAPTATION OF THIS CHAMBER SYSTEM TO SPECIFIC SITE AND DESIGN CONSTRAINTS, IT MAY BE NECESSARY TO CUT AND COUPLE ADDITIONAL PIPE TO STANDARD MANIFOLD COMPONENTS IN THE FIELD.
- THE SITE DESIGN ENGINEER MUST REVIEW ELEVATIONS AND IF NECESSARY ADJUST GRADING TO ENSURE THE CHAMBER COVER REQUIREMENTS ARE MET.
- THIS CHAMBER SYSTEM WAS DESIGNED WITHOUT SITE-SPECIFIC INFORMATION ON SOIL CONDITIONS OR BEARING CAPACITY. THE SITE DESIGN ENGINEER IS RESPONSIBLE FOR DETERMINING THE SUITABILITY OF THE SOIL AND PROVIDING THE BEARING CAPACITY OF THE INSITU SOILS. THE BASE STONE DEPTH MAY BE INCREASED OR DECREASED ONCE THIS INFORMATION IS PROVIDED..

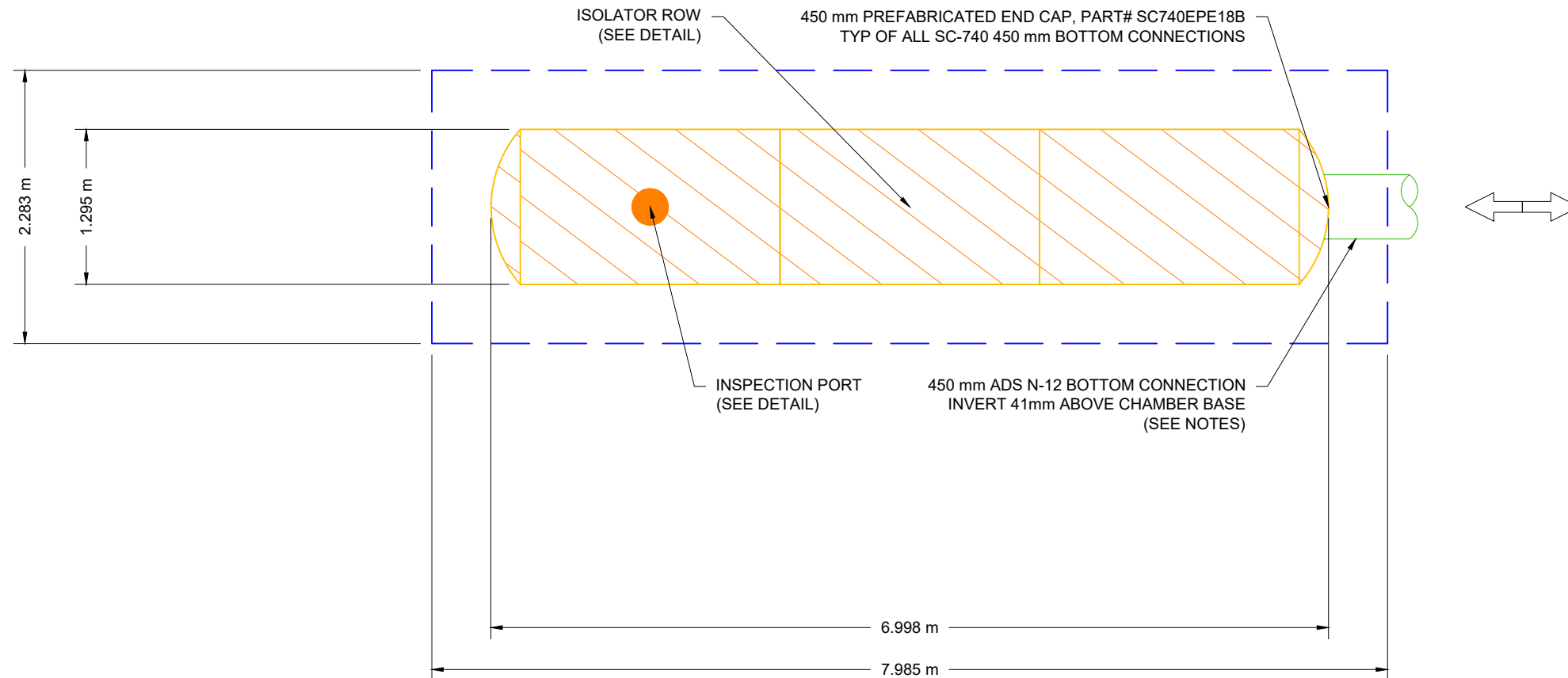

**ADS**  
ADVANCED DRAINAGE SYSTEMS, INC.

SCALE = 1 : 50

4640 TRUEMAN BLVD  
HILLIARD, OH 43026

HARD ROCK OTTAWA  
OTTAWA, ON.

DATE: 06/12/20 DRAWN: RCT  
PROJECT #: S188516 CHECKED: JMQ

DATE	DRWN	CHKD	DESCRIPTION

THIS DRAWING HAS BEEN PREPARED BASED ON INFORMATION PROVIDED TO ADS UNDER THE DIRECTION OF THE SITE DESIGN ENGINEER OR OTHER PROJECT REPRESENTATIVE. THE SITE DESIGN ENGINEER SHALL REVIEW THIS DRAWING PRIOR TO CONSTRUCTION. IT IS THE ULTIMATE RESPONSIBILITY OF THE SITE DESIGN ENGINEER TO ENSURE THAT THE PRODUCT(S) DEPICTED AND ALL ASSOCIATED DETAILS MEET ALL APPLICABLE LAWS, REGULATIONS, AND PROJECT REQUIREMENTS.

**PROPOSED LAYOUT - SYSTEM 17**

12	STORMTECH SC-740 CHAMBERS
6	STORMTECH SC-740 END CAPS
152	STONE ABOVE (mm)
300	STONE BELOW (mm)
40	% STONE VOID
<b>26.3</b>	<b>INSTALLED SYSTEM VOLUME (m³) ABOVE ELEVATION 111.800 (PERIMETER STONE INCLUDED)</b>
<b>7.5</b>	<b>INSTALLED SYSTEM VOLUME (m³) BELOW ELEVATION 111.800 (PERIMETER STONE INCLUDED)</b>
50.3	SYSTEM AREA (m²)
30.5	SYSTEM PERIMETER (m)

**PROPOSED ELEVATIONS - SYSTEM 17**

114.959	MAXIMUM ALLOWABLE GRADE (TOP OF PAVEMENT/UNPAVED):
113.131	MINIMUM ALLOWABLE GRADE (UNPAVED WITH TRAFFIC):
112.978	MINIMUM ALLOWABLE GRADE (UNPAVED NO TRAFFIC):
112.978	MINIMUM ALLOWABLE GRADE (BASE OF FLEXIBLE PAVEMENT):
112.978	MINIMUM ALLOWABLE GRADE (TOP OF RIGID PAVEMENT):
112.673	TOP OF STONE:
112.521	TOP OF SC-740 CHAMBER:
111.950	300 mm CUSTOM MANIFOLD INVERT:
111.800	450 mm ISOLATOR ROW INVERT:
111.759	BOTTOM OF SC-740 CHAMBER:
111.459	BOTTOM OF STONE:

**NOTES**

- MANIFOLD SIZE TO BE DETERMINED BY SITE DESIGN ENGINEER. SEE TECHNICAL NOTE 6.32 FOR MANIFOLD SIZING GUIDANCE.
- DUE TO THE ADAPTATION OF THIS CHAMBER SYSTEM TO SPECIFIC SITE AND DESIGN CONSTRAINTS, IT MAY BE NECESSARY TO CUT AND COUPLE ADDITIONAL PIPE TO STANDARD MANIFOLD COMPONENTS IN THE FIELD.
- THE SITE DESIGN ENGINEER MUST REVIEW ELEVATIONS AND IF NECESSARY ADJUST GRADING TO ENSURE THE CHAMBER COVER REQUIREMENTS ARE MET.
- THIS CHAMBER SYSTEM WAS DESIGNED WITHOUT SITE-SPECIFIC INFORMATION ON SOIL CONDITIONS OR BEARING CAPACITY. THE SITE DESIGN ENGINEER IS RESPONSIBLE FOR DETERMINING THE SUITABILITY OF THE SOIL AND PROVIDING THE BEARING CAPACITY OF THE INSITU SOILS. THE BASE STONE DEPTH MAY BE INCREASED OR DECREASED ONCE THIS INFORMATION IS PROVIDED..

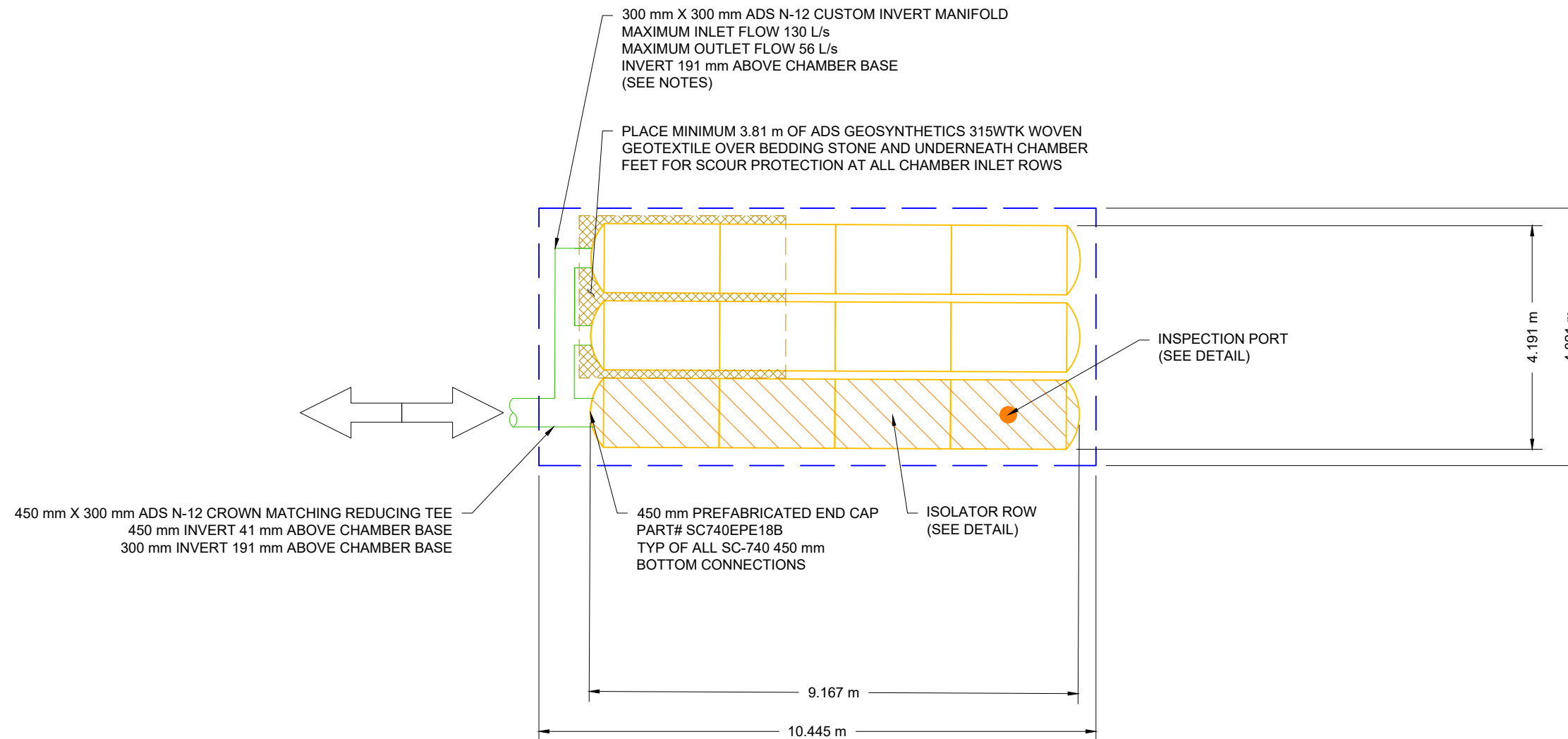

HARD ROCK OTTAWA	
OTTAWA, ON.	
DATE: 06/12/20	DRAWN: RCT
PROJECT #: S188516	CHECKED: JMQ

DATE	DRWN	CHKD	DESCRIPTION

**StormTech**  
 Retention • Retention • Water Quality  
 520 CROMWELL AVENUE | ROCKY HILL | CT | 06067  
 860-529-8188 | 888-892-2894 | WWW.STORMTECH.COM

**ADS**  
 ADVANCED DRAINAGE SYSTEMS, INC.  
 4640 TRUEMAN BLVD  
 HILLIARD, OH 43026

**SCALE = 1 : 100**

THIS DRAWING HAS BEEN PREPARED BASED ON INFORMATION PROVIDED TO ADS UNDER THE DIRECTION OF THE SITE DESIGN ENGINEER OR OTHER PROJECT REPRESENTATIVE. THE SITE DESIGN ENGINEER SHALL REVIEW THIS DRAWING PRIOR TO CONSTRUCTION. IT IS THE ULTIMATE RESPONSIBILITY OF THE SITE DESIGN ENGINEER TO ENSURE THAT THE PRODUCT(S) DEPICTED AND ALL ASSOCIATED DETAILS MEET ALL APPLICABLE LAWS, REGULATIONS, AND PROJECT REQUIREMENTS.

**PROPOSED LAYOUT - SYSTEM 18**

28	STORMTECH SC-740 CHAMBERS
6	STORMTECH SC-740 END CAPS
152	STONE ABOVE (mm)
300	STONE BELOW (mm)
40	% STONE VOID
<b>59.3</b>	<b>INSTALLED SYSTEM VOLUME (m³) ABOVE ELEVATION 111.650 (PERIMETER STONE INCLUDED)</b>
<b>16.7</b>	<b>INSTALLED SYSTEM VOLUME (m³) BELOW ELEVATION 111.650 (PERIMETER STONE INCLUDED)</b>
111.2	SYSTEM AREA (m²)
47.2	SYSTEM PERIMETER (m)

**PROPOSED ELEVATIONS - SYSTEM 18**

113.809	MAXIMUM ALLOWABLE GRADE (TOP OF PAVEMENT/UNPAVED):
111.981	MINIMUM ALLOWABLE GRADE (UNPAVED WITH TRAFFIC):
111.828	MINIMUM ALLOWABLE GRADE (UNPAVED NO TRAFFIC):
111.828	MINIMUM ALLOWABLE GRADE (BASE OF FLEXIBLE PAVEMENT):
111.828	MINIMUM ALLOWABLE GRADE (TOP OF RIGID PAVEMENT):
111.523	TOP OF STONE:
111.371	TOP OF SC-740 CHAMBER:
110.800	300 mm CUSTOM MANIFOLD INVERT:
110.650	450 mm ISOLATOR ROW INVERT:
110.609	BOTTOM OF SC-740 CHAMBER:
110.309	BOTTOM OF STONE:

**NOTES**

- MANIFOLD SIZE TO BE DETERMINED BY SITE DESIGN ENGINEER. SEE TECHNICAL NOTE 6.32 FOR MANIFOLD SIZING GUIDANCE.
- DUE TO THE ADAPTATION OF THIS CHAMBER SYSTEM TO SPECIFIC SITE AND DESIGN CONSTRAINTS, IT MAY BE NECESSARY TO CUT AND COUPLE ADDITIONAL PIPE TO STANDARD MANIFOLD COMPONENTS IN THE FIELD.
- THE SITE DESIGN ENGINEER MUST REVIEW ELEVATIONS AND IF NECESSARY ADJUST GRADING TO ENSURE THE CHAMBER COVER REQUIREMENTS ARE MET.
- THIS CHAMBER SYSTEM WAS DESIGNED WITHOUT SITE-SPECIFIC INFORMATION ON SOIL CONDITIONS OR BEARING CAPACITY. THE SITE DESIGN ENGINEER IS RESPONSIBLE FOR DETERMINING THE SUITABILITY OF THE SOIL AND PROVIDING THE BEARING CAPACITY OF THE INSITU SOILS. THE BASE STONE DEPTH MAY BE INCREASED OR DECREASED ONCE THIS INFORMATION IS PROVIDED..

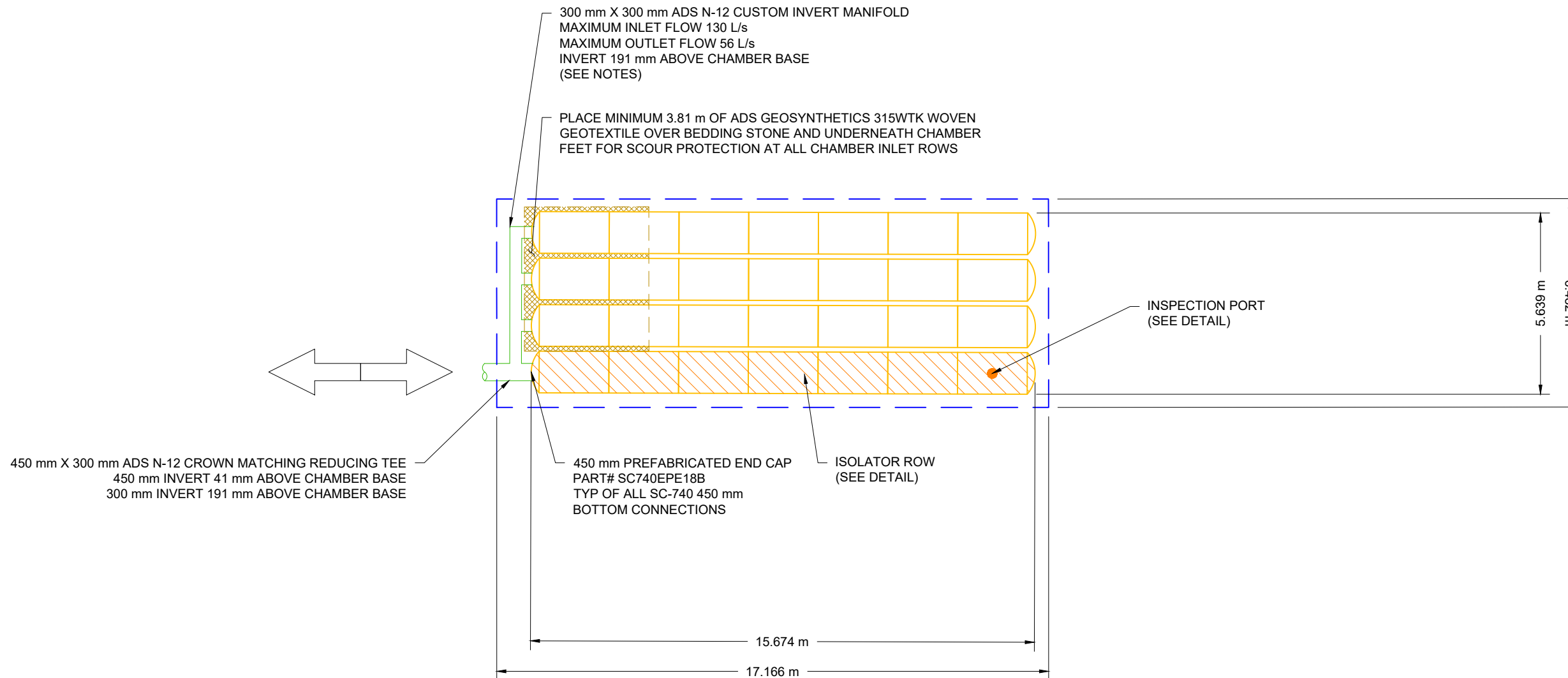

HARD ROCK OTTAWA	
OTTAWA, ON.	
DATE: 06/12/20	DRAWN: RCT
PROJECT #: S188516	CHECKED: JMQ

DATE	DRWN	CHKD	DESCRIPTION

**StormTech**  
Retention • Retention • Water Quality  
 520 CROMWELL AVENUE | ROCKY HILL | CT | 06067  
 860-529-8188 | 888-892-2894 | WWW.STORMTECH.COM

**ADS**  
ADVANCED DRAINAGE SYSTEMS, INC.  
 4640 TRUEMAN BLVD  
 HILLIARD, OH 43026

**SCALE = 1 : 150**

THIS DRAWING HAS BEEN PREPARED BASED ON INFORMATION PROVIDED TO ADS UNDER THE DIRECTION OF THE SITE DESIGN ENGINEER OR OTHER PROJECT REPRESENTATIVE. THE SITE DESIGN ENGINEER SHALL REVIEW THIS DRAWING PRIOR TO CONSTRUCTION. IT IS THE ULTIMATE RESPONSIBILITY OF THE SITE DESIGN ENGINEER TO ENSURE THAT THE PRODUCT(S) DEPICTED AND ALL ASSOCIATED DETAILS MEET ALL APPLICABLE LAWS, REGULATIONS, AND PROJECT REQUIREMENTS.



**PROPOSED LAYOUT - SYSTEM 19**

40	STORMTECH SC-740 CHAMBERS
10	STORMTECH SC-740 END CAPS
152	STONE ABOVE (mm)
300	STONE BELOW (mm)
40	% STONE VOID
<b>85.8</b>	<b>INSTALLED SYSTEM VOLUME (m<sup>3</sup>) ABOVE ELEVATION 110.740 (PERIMETER STONE INCLUDED)</b>
<b>18.1</b>	<b>INSTALLED SYSTEM VOLUME (m<sup>3</sup>) BELOW ELEVATION 110.740 (PERIMETER STONE INCLUDED)</b>
149.1	SYSTEM AREA (m <sup>2</sup> )
53.9	SYSTEM PERIMETER (m)

**PROPOSED ELEVATIONS - SYSTEM 19**

113.937	MAXIMUM ALLOWABLE GRADE (TOP OF PAVEMENT/UNPAVED):
112.109	MINIMUM ALLOWABLE GRADE (UNPAVED WITH TRAFFIC):
111.956	MINIMUM ALLOWABLE GRADE (UNPAVED NO TRAFFIC):
111.956	MINIMUM ALLOWABLE GRADE (BASE OF FLEXIBLE PAVEMENT):
111.956	MINIMUM ALLOWABLE GRADE (TOP OF RIGID PAVEMENT):
111.651	TOP OF STONE:
111.499	TOP OF SC-740 CHAMBER:
111.055	300 mm TOP MANIFOLD INVERT:
110.740	600 mm ISOLATOR ROW INVERT:
110.737	BOTTOM OF SC-740 CHAMBER:
110.437	BOTTOM OF STONE:

**NOTES**

- MANIFOLD SIZE TO BE DETERMINED BY SITE DESIGN ENGINEER. SEE TECHNICAL NOTE 6.32 FOR MANIFOLD SIZING GUIDANCE.
- DUE TO THE ADAPTATION OF THIS CHAMBER SYSTEM TO SPECIFIC SITE AND DESIGN CONSTRAINTS, IT MAY BE NECESSARY TO CUT AND COUPLE ADDITIONAL PIPE TO STANDARD MANIFOLD COMPONENTS IN THE FIELD.
- THE SITE DESIGN ENGINEER MUST REVIEW ELEVATIONS AND IF NECESSARY ADJUST GRADING TO ENSURE THE CHAMBER COVER REQUIREMENTS ARE MET.
- THIS CHAMBER SYSTEM WAS DESIGNED WITHOUT SITE-SPECIFIC INFORMATION ON SOIL CONDITIONS OR BEARING CAPACITY. THE SITE DESIGN ENGINEER IS RESPONSIBLE FOR DETERMINING THE SUITABILITY OF THE SOIL AND PROVIDING THE BEARING CAPACITY OF THE INSITU SOILS. THE BASE STONE DEPTH MAY BE INCREASED OR DECREASED ONCE THIS INFORMATION IS PROVIDED..

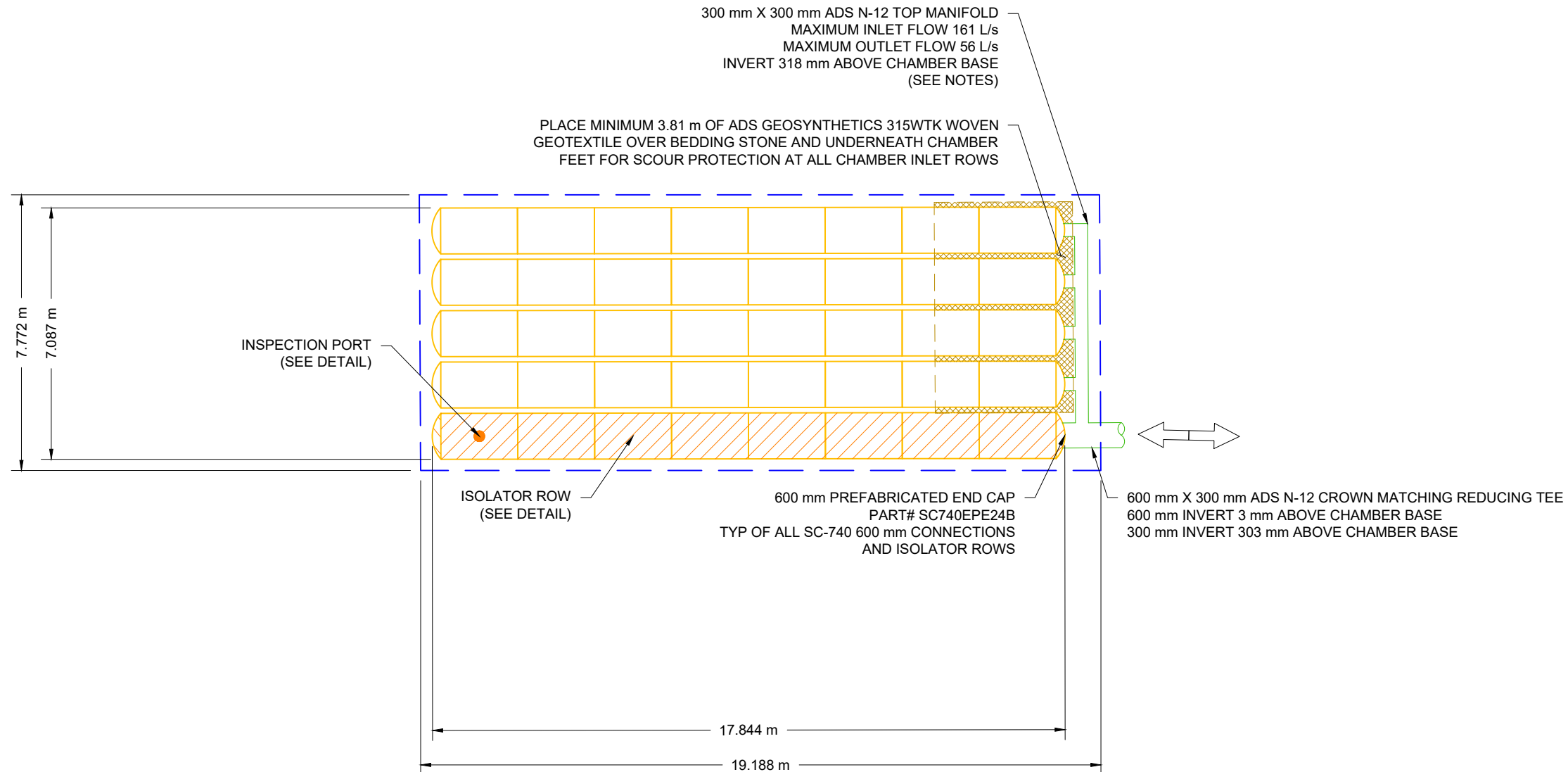

HARD ROCK OTTAWA	
OTTAWA, ON.	
DATE: 06/12/20	DRAWN: RCT
PROJECT #: S188516	CHECKED: JMQ

DATE	DRWN	CHKD	DESCRIPTION

**StormTech**  
 Attention: Retention + Water Quality  
 520 CROMWELL AVENUE | ROCKY HILL | CT | 06067  
 860-529-8188 | 888-892-2894 | WWW.STORMTECH.COM

**ADS**  
 ADVANCED DRAINAGE SYSTEMS, INC.  
 4640 TRUEMAN BLVD  
 HILLIARD, OH 43026  
**SCALE = 1 : 150**

THIS DRAWING HAS BEEN PREPARED BASED ON INFORMATION PROVIDED TO ADS UNDER THE DIRECTION OF THE SITE DESIGN ENGINEER OR OTHER PROJECT REPRESENTATIVE. THE SITE DESIGN ENGINEER SHALL REVIEW THIS DRAWING PRIOR TO CONSTRUCTION. IT IS THE ULTIMATE RESPONSIBILITY OF THE SITE DESIGN ENGINEER TO ENSURE THAT THE PRODUCT(S) DEPICTED AND ALL ASSOCIATED DETAILS MEET ALL APPLICABLE LAWS, REGULATIONS, AND PROJECT REQUIREMENTS.

**PROPOSED LAYOUT - SYSTEM 20**

30	STORMTECH SC-740 CHAMBERS
12	STORMTECH SC-740 END CAPS
152	STONE ABOVE (mm)
300	STONE BELOW (mm)
40	% STONE VOID
<b>63.8</b>	<b>INSTALLED SYSTEM VOLUME (m³) ABOVE ELEVATION 111.250 (PERIMETER STONE INCLUDED)</b>
<b>18.1</b>	<b>INSTALLED SYSTEM VOLUME (m³) BELOW ELEVATION 111.250 (PERIMETER STONE INCLUDED)</b>
119.9	SYSTEM AREA (m²)
44.3	SYSTEM PERIMETER (m)

**PROPOSED ELEVATIONS - SYSTEM 20**

114.409	MAXIMUM ALLOWABLE GRADE (TOP OF PAVEMENT/UNPAVED):
112.581	MINIMUM ALLOWABLE GRADE (UNPAVED WITH TRAFFIC):
112.428	MINIMUM ALLOWABLE GRADE (UNPAVED NO TRAFFIC):
112.428	MINIMUM ALLOWABLE GRADE (BASE OF FLEXIBLE PAVEMENT):
112.428	MINIMUM ALLOWABLE GRADE (TOP OF RIGID PAVEMENT):
112.123	TOP OF STONE:
111.971	TOP OF SC-740 CHAMBER:
111.400	300 mm CUSTOM MANIFOLD INVERT:
111.250	450 mm ISOLATOR ROW INVERT:
111.209	BOTTOM OF SC-740 CHAMBER:
110.909	BOTTOM OF STONE:

**NOTES**

- MANIFOLD SIZE TO BE DETERMINED BY SITE DESIGN ENGINEER. SEE TECHNICAL NOTE 6.32 FOR MANIFOLD SIZING GUIDANCE.
- DUE TO THE ADAPTATION OF THIS CHAMBER SYSTEM TO SPECIFIC SITE AND DESIGN CONSTRAINTS, IT MAY BE NECESSARY TO CUT AND COUPLE ADDITIONAL PIPE TO STANDARD MANIFOLD COMPONENTS IN THE FIELD.
- THE SITE DESIGN ENGINEER MUST REVIEW ELEVATIONS AND IF NECESSARY ADJUST GRADING TO ENSURE THE CHAMBER COVER REQUIREMENTS ARE MET.
- THIS CHAMBER SYSTEM WAS DESIGNED WITHOUT SITE-SPECIFIC INFORMATION ON SOIL CONDITIONS OR BEARING CAPACITY. THE SITE DESIGN ENGINEER IS RESPONSIBLE FOR DETERMINING THE SUITABILITY OF THE SOIL AND PROVIDING THE BEARING CAPACITY OF THE INSITU SOILS. THE BASE STONE DEPTH MAY BE INCREASED OR DECREASED ONCE THIS INFORMATION IS PROVIDED..

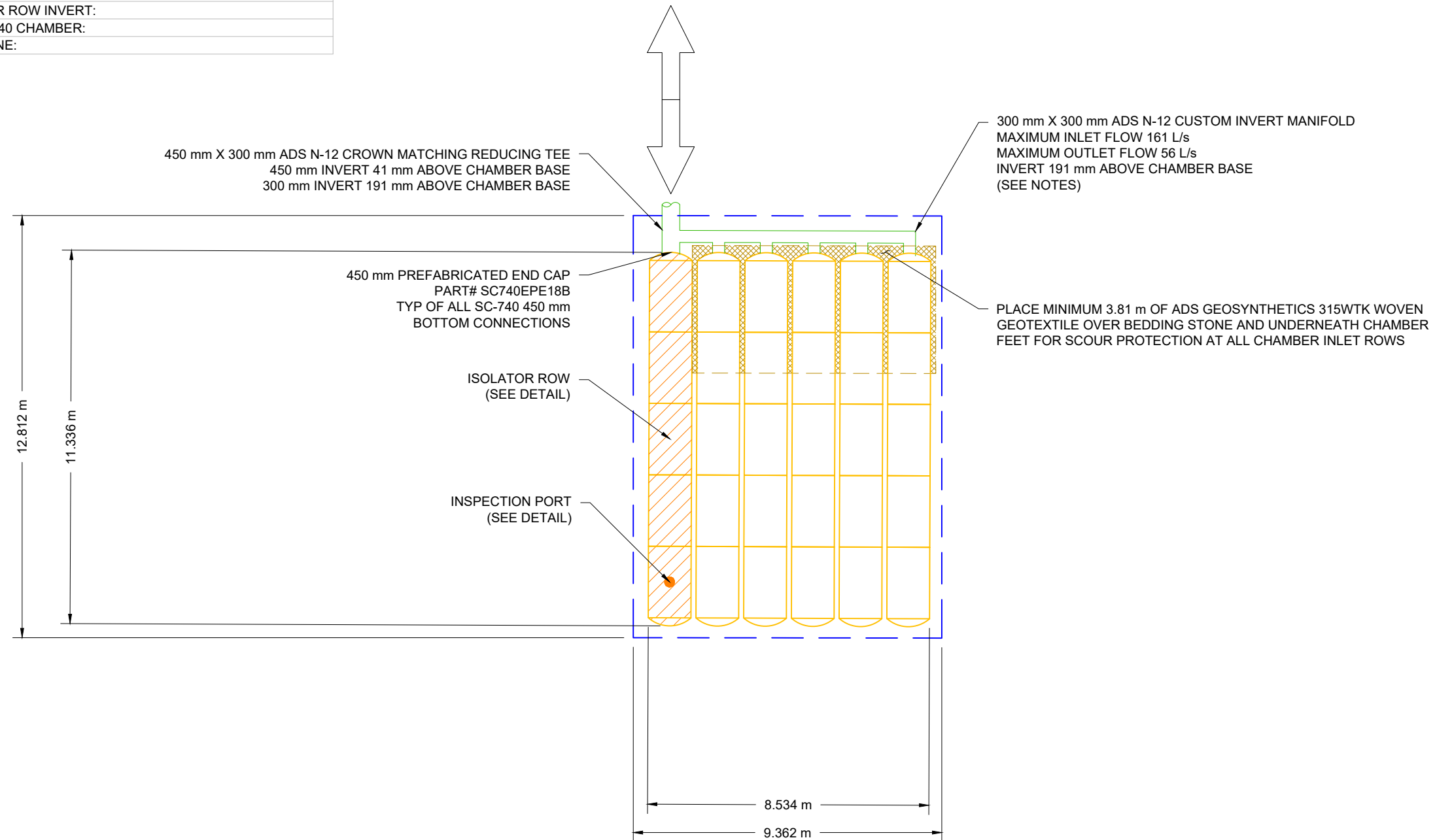

HARD ROCK OTTAWA	
OTTAWA, ON.	
DATE: 06/12/20	DRAWN: RCT
PROJECT #: S188516	CHECKED: JMQ

DATE	DRWN	CHKD	DESCRIPTION

**StormTech**  
Retention • Retention • Water Quality

520 CROMWELL AVENUE | ROCKY HILL | CT | 06067  
860-529-8188 | 888-892-2894 | WWW.STORMTECH.COM

**ADS**  
ADVANCED DRAINAGE SYSTEMS, INC.

4640 TRUEMAN BLVD  
HILLIARD, OH 43026

SCALE = 1 : 150

THIS DRAWING HAS BEEN PREPARED BASED ON INFORMATION PROVIDED TO ADS UNDER THE DIRECTION OF THE SITE DESIGN ENGINEER OR OTHER PROJECT REPRESENTATIVE. THE SITE DESIGN ENGINEER SHALL REVIEW THIS DRAWING PRIOR TO CONSTRUCTION. IT IS THE ULTIMATE RESPONSIBILITY OF THE SITE DESIGN ENGINEER TO ENSURE THAT THE PRODUCT(S) DEPICTED AND ALL ASSOCIATED DETAILS MEET ALL APPLICABLE LAWS, REGULATIONS, AND PROJECT REQUIREMENTS.

## ACCEPTABLE FILL MATERIALS: STORMTECH SC-740 CHAMBER SYSTEMS

MATERIAL LOCATION		DESCRIPTION	AASHTO MATERIAL CLASSIFICATIONS	COMPACTION / DENSITY REQUIREMENT
D	<b>FINAL FILL:</b> FILL MATERIAL FOR LAYER 'D' STARTS FROM THE TOP OF THE 'C' LAYER TO THE BOTTOM OF FLEXIBLE PAVEMENT OR UNPAVED FINISHED GRADE ABOVE. NOTE THAT PAVEMENT SUBBASE MAY BE PART OF THE 'D' LAYER.	ANY SOIL/ROCK MATERIALS, NATIVE SOILS, OR PER ENGINEER'S PLANS. CHECK PLANS FOR PAVEMENT SUBGRADE REQUIREMENTS.	N/A	PREPARE PER SITE DESIGN ENGINEER'S PLANS. PAVED INSTALLATIONS MAY HAVE STRINGENT MATERIAL AND PREPARATION REQUIREMENTS.
C	<b>INITIAL FILL:</b> FILL MATERIAL FOR LAYER 'C' STARTS FROM THE TOP OF THE EMBEDMENT STONE ('B' LAYER) TO 18" (450 mm) ABOVE THE TOP OF THE CHAMBER. NOTE THAT PAVEMENT SUBBASE MAY BE A PART OF THE 'C' LAYER.	GRANULAR WELL-GRADED SOIL/AGGREGATE MIXTURES, <35% FINES OR PROCESSED AGGREGATE.  MOST PAVEMENT SUBBASE MATERIALS CAN BE USED IN LIEU OF THIS LAYER.	AASHTO M145 <sup>1</sup> A-1, A-2-4, A-3  OR AASHTO M43 <sup>1</sup> 3, 357, 4, 467, 5, 56, 57, 6, 67, 68, 7, 78, 8, 89, 9, 10	BEGIN COMPACTIONS AFTER 12" (300 mm) OF MATERIAL OVER THE CHAMBERS IS REACHED. COMPACT ADDITIONAL LAYERS IN 6" (150 mm) MAX LIFTS TO A MIN. 95% PROCTOR DENSITY FOR WELL GRADED MATERIAL AND 95% RELATIVE DENSITY FOR PROCESSED AGGREGATE MATERIALS. ROLLER GROSS VEHICLE WEIGHT NOT TO EXCEED 12,000 lbs (53 kN). DYNAMIC FORCE NOT TO EXCEED 20,000 lbs (89 kN).
B	<b>EMBEDMENT STONE:</b> FILL SURROUNDING THE CHAMBERS FROM THE FOUNDATION STONE ('A' LAYER) TO THE 'C' LAYER ABOVE.	CLEAN, CRUSHED, ANGULAR STONE	AASHTO M43 <sup>1</sup> 3, 357, 4, 467, 5, 56, 57	NO COMPACTION REQUIRED.
A	<b>FOUNDATION STONE:</b> FILL BELOW CHAMBERS FROM THE SUBGRADE UP TO THE FOOT (BOTTOM) OF THE CHAMBER.	CLEAN, CRUSHED, ANGULAR STONE	AASHTO M43 <sup>1</sup> 3, 357, 4, 467, 5, 56, 57	PLATE COMPACT OR ROLL TO ACHIEVE A FLAT SURFACE. <sup>2,3</sup>

**PLEASE NOTE:**

- THE LISTED AASHTO DESIGNATIONS ARE FOR GRADATIONS ONLY. THE STONE MUST ALSO BE CLEAN, CRUSHED, ANGULAR. FOR EXAMPLE, A SPECIFICATION FOR #4 STONE WOULD STATE: "CLEAN, CRUSHED, ANGULAR NO. 4 (AASHTO M43) STONE".
- STORMTECH COMPACTION REQUIREMENTS ARE MET FOR 'A' LOCATION MATERIALS WHEN PLACED AND COMPACTED IN 6" (150 mm) (MAX) LIFTS USING TWO FULL COVERAGES WITH A VIBRATORY COMPACTOR.
- WHERE INFILTRATION SURFACES MAY BE COMPROMISED BY COMPACTION, FOR STANDARD DESIGN LOAD CONDITIONS, A FLAT SURFACE MAY BE ACHIEVED BY RAKING OR DRAGGING WITHOUT COMPACTION EQUIPMENT. FOR SPECIAL LOAD DESIGNS, CONTACT STORMTECH FOR COMPACTION REQUIREMENTS.
- ONCE LAYER 'C' IS PLACED, ANY SOIL/MATERIAL CAN BE PLACED IN LAYER 'D' UP TO THE FINISHED GRADE. MOST PAVEMENT SUBBASE SOILS CAN BE USED TO REPLACE THE MATERIAL REQUIREMENTS OF LAYER 'C' OR 'D' AT THE SITE DESIGN ENGINEER'S DISCRETION.

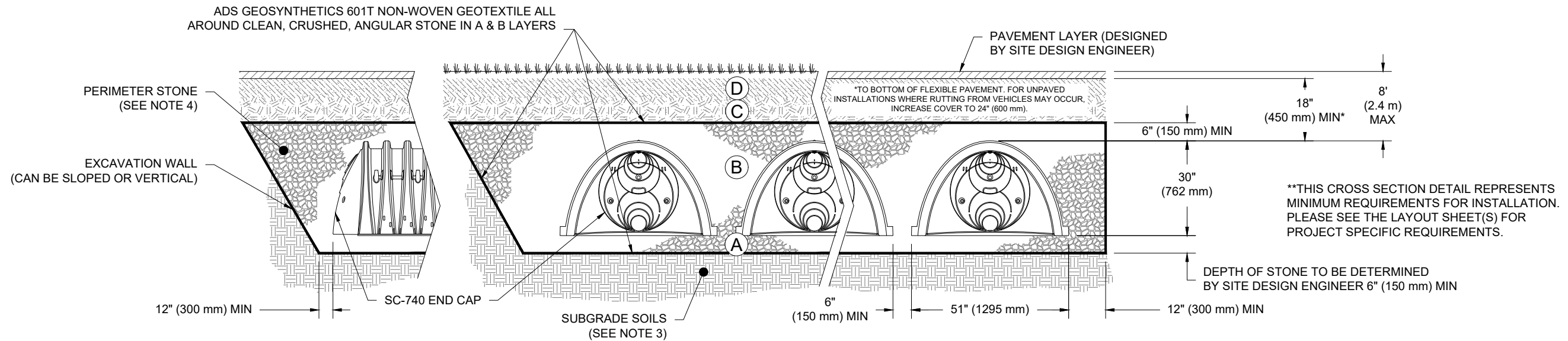

**NOTES:**

- CHAMBERS SHALL MEET THE REQUIREMENTS OF ASTM F2418-16a, "STANDARD SPECIFICATION FOR POLYPROPYLENE (PP) CORRUGATED WALL STORMWATER COLLECTION CHAMBERS".
- SC-740 CHAMBERS SHALL BE DESIGNED IN ACCORDANCE WITH ASTM F2787 "STANDARD PRACTICE FOR STRUCTURAL DESIGN OF THERMOPLASTIC CORRUGATED WALL STORMWATER COLLECTION CHAMBERS".
- THE SITE DESIGN ENGINEER IS RESPONSIBLE FOR ASSESSING THE BEARING RESISTANCE (ALLOWABLE BEARING CAPACITY) OF THE SUBGRADE SOILS AND THE DEPTH OF FOUNDATION STONE WITH CONSIDERATION FOR THE RANGE OF EXPECTED SOIL MOISTURE CONDITIONS.
- PERIMETER STONE MUST BE EXTENDED HORIZONTALLY TO THE EXCAVATION WALL FOR BOTH VERTICAL AND SLOPED EXCAVATION WALLS.
- REQUIREMENTS FOR HANDLING AND INSTALLATION:
  - TO MAINTAIN THE WIDTH OF CHAMBERS DURING SHIPPING AND HANDLING, CHAMBERS SHALL HAVE INTEGRAL, INTERLOCKING STACKING LUGS.
  - TO ENSURE A SECURE JOINT DURING INSTALLATION AND BACKFILL, THE HEIGHT OF THE CHAMBER JOINT SHALL NOT BE LESS THAN 2".
  - TO ENSURE THE INTEGRITY OF THE ARCH SHAPE DURING INSTALLATION, a) THE ARCH STIFFNESS CONSTANT AS DEFINED IN SECTION 6.2.8 OF ASTM F2418 SHALL BE GREATER THAN OR EQUAL TO 550 LBS/IN/IN. AND b) TO RESIST CHAMBER DEFORMATION DURING INSTALLATION AT ELEVATED TEMPERATURES (ABOVE 73° F / 23° C), CHAMBERS SHALL BE PRODUCED FROM REFLECTIVE GOLD OR YELLOW COLORS.

HARD ROCK OTTAWA

OTTAWA, ON.

DATE: 06/12/20

DRAWN: RCT

PROJECT #: S188516

CHECKED: JMQ

**StormTech**  
Retention • Retention • Water Quality

520 CROMWELL AVENUE | ROCKY HILL | CT | 06067  
860-529-8188 | 888-892-2894 | WWW.STORMTECH.COM

4640 TRUEMAN BLVD  
HILLIARD, OH 43026

**ADS**  
ADVANCED DRAINAGE SYSTEMS, INC.

THIS DRAWING HAS BEEN PREPARED BASED ON INFORMATION PROVIDED TO ADS UNDER THE DIRECTION OF THE SITE DESIGN ENGINEER OR OTHER PROJECT REPRESENTATIVE. THE SITE DESIGN ENGINEER SHALL REVIEW THIS DRAWING PRIOR TO CONSTRUCTION. IT IS THE ULTIMATE RESPONSIBILITY OF THE SITE DESIGN ENGINEER TO ENSURE THAT THE PRODUCT(S) DEPICTED AND ALL ASSOCIATED DETAILS MEET ALL APPLICABLE LAWS, REGULATIONS, AND PROJECT REQUIREMENTS.

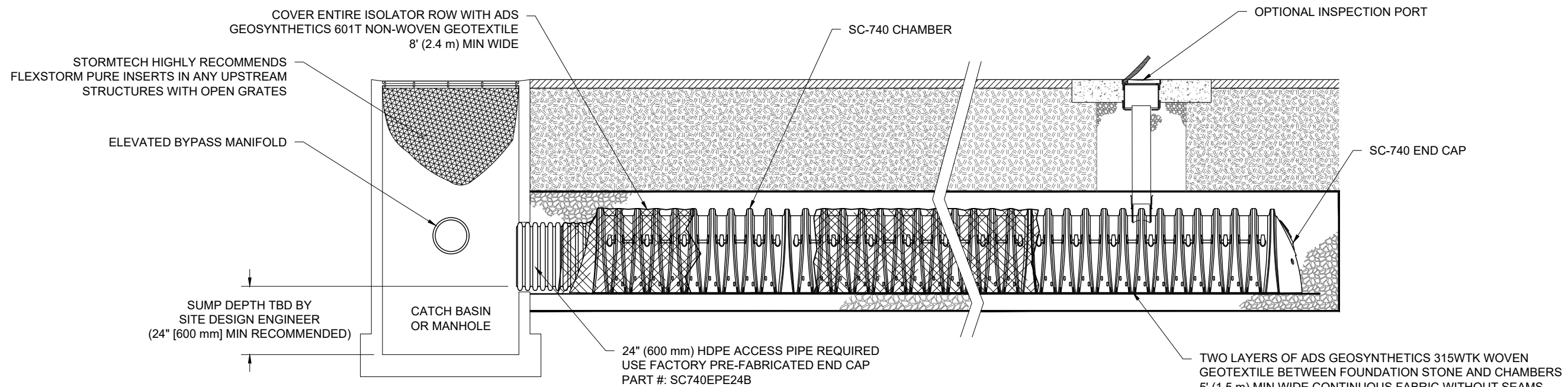

**SC-740 ISOLATOR ROW DETAIL**  
NTS

**INSPECTION & MAINTENANCE**

- STEP 1) INSPECT ISOLATOR ROW FOR SEDIMENT
- A. INSPECTION PORTS (IF PRESENT)
    - A.1. REMOVE/OPEN LID ON NYLOPLAST INLINE DRAIN
    - A.2. REMOVE AND CLEAN FLEXSTORM FILTER IF INSTALLED
    - A.3. USING A FLASHLIGHT AND STADIA ROD, MEASURE DEPTH OF SEDIMENT AND RECORD ON MAINTENANCE LOG
    - A.4. LOWER A CAMERA INTO ISOLATOR ROW FOR VISUAL INSPECTION OF SEDIMENT LEVELS (OPTIONAL)
    - A.5. IF SEDIMENT IS AT, OR ABOVE, 3" (80 mm) PROCEED TO STEP 2. IF NOT, PROCEED TO STEP 3.
  - B. ALL ISOLATOR ROWS
    - B.1. REMOVE COVER FROM STRUCTURE AT UPSTREAM END OF ISOLATOR ROW
    - B.2. USING A FLASHLIGHT, INSPECT DOWN THE ISOLATOR ROW THROUGH OUTLET PIPE
      - i) MIRRORS ON POLES OR CAMERAS MAY BE USED TO AVOID A CONFINED SPACE ENTRY
      - ii) FOLLOW OSHA REGULATIONS FOR CONFINED SPACE ENTRY IF ENTERING MANHOLE
    - B.3. IF SEDIMENT IS AT, OR ABOVE, 3" (80 mm) PROCEED TO STEP 2. IF NOT, PROCEED TO STEP 3.
- STEP 2) CLEAN OUT ISOLATOR ROW USING THE JETVAC PROCESS
- A. A FIXED CULVERT CLEANING NOZZLE WITH REAR FACING SPREAD OF 45" (1.1 m) OR MORE IS PREFERRED
  - B. APPLY MULTIPLE PASSES OF JETVAC UNTIL BACKFLUSH WATER IS CLEAN
  - C. VACUUM STRUCTURE SUMP AS REQUIRED
- STEP 3) REPLACE ALL COVERS, GRATES, FILTERS, AND LIDS; RECORD OBSERVATIONS AND ACTIONS.
- STEP 4) INSPECT AND CLEAN BASINS AND MANHOLES UPSTREAM OF THE STORMTECH SYSTEM.

**NOTES**

1. INSPECT EVERY 6 MONTHS DURING THE FIRST YEAR OF OPERATION. ADJUST THE INSPECTION INTERVAL BASED ON PREVIOUS OBSERVATIONS OF SEDIMENT ACCUMULATION AND HIGH WATER ELEVATIONS.
2. CONDUCT JETTING AND VACTORING ANNUALLY OR WHEN INSPECTION SHOWS THAT MAINTENANCE IS NECESSARY.

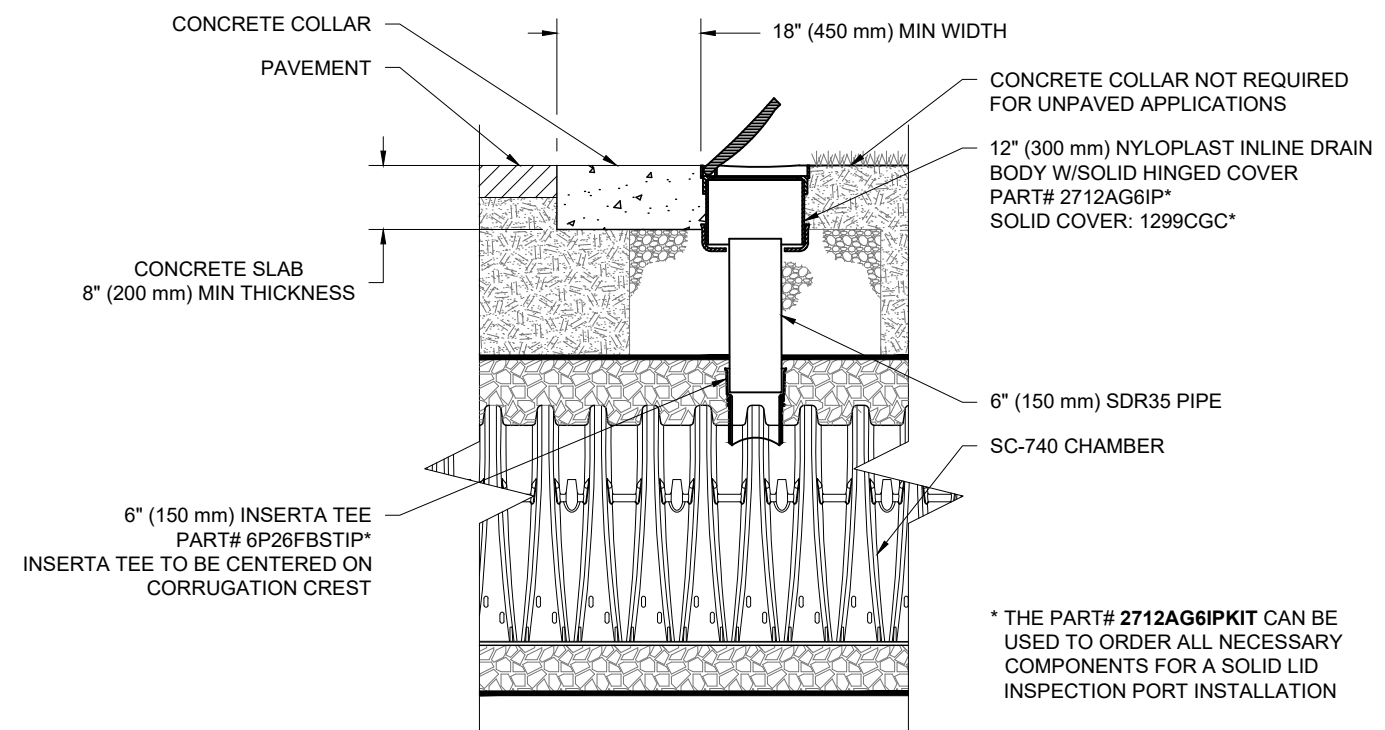

**SC-740 6" (150 mm) INSPECTION PORT DETAIL**  
NTS

<b>HARD ROCK OTTAWA</b>	
OTTAWA, ON.	
DATE: 06/12/20	DRAWN: RCT
PROJECT #: S188516	CHECKED: JMQ
	DESCRIPTION
	DATE
	DRWN
	CHKD
<p style="font-size: small; margin: 0;">520 CROMWELL AVENUE   ROCKY HILL   CT   06067 860-525-8188   888-892-2894   WWW.STORMTECH.COM</p>	
4640 TRUEMAN BLVD HILLIARD, OH 43026 <b>ADS</b> ADVANCED DRAINAGE SYSTEMS, INC.	
THIS DRAWING HAS BEEN PREPARED BASED ON INFORMATION PROVIDED TO ADS UNDER THE DIRECTION OF THE SITE DESIGN ENGINEER OR OTHER PROJECT REPRESENTATIVE. THE SITE DESIGN ENGINEER SHALL REVIEW THIS DRAWING PRIOR TO CONSTRUCTION. IT IS THE ULTIMATE RESPONSIBILITY OF THE SITE DESIGN ENGINEER TO ENSURE THAT THE PRODUCT(S) DEPICTED AND ALL ASSOCIATED DETAILS MEET ALL APPLICABLE LAWS, REGULATIONS, AND PROJECT REQUIREMENTS.	
SHEET <b>23 OF 24</b>	

# SC-740 TECHNICAL SPECIFICATION

NTS

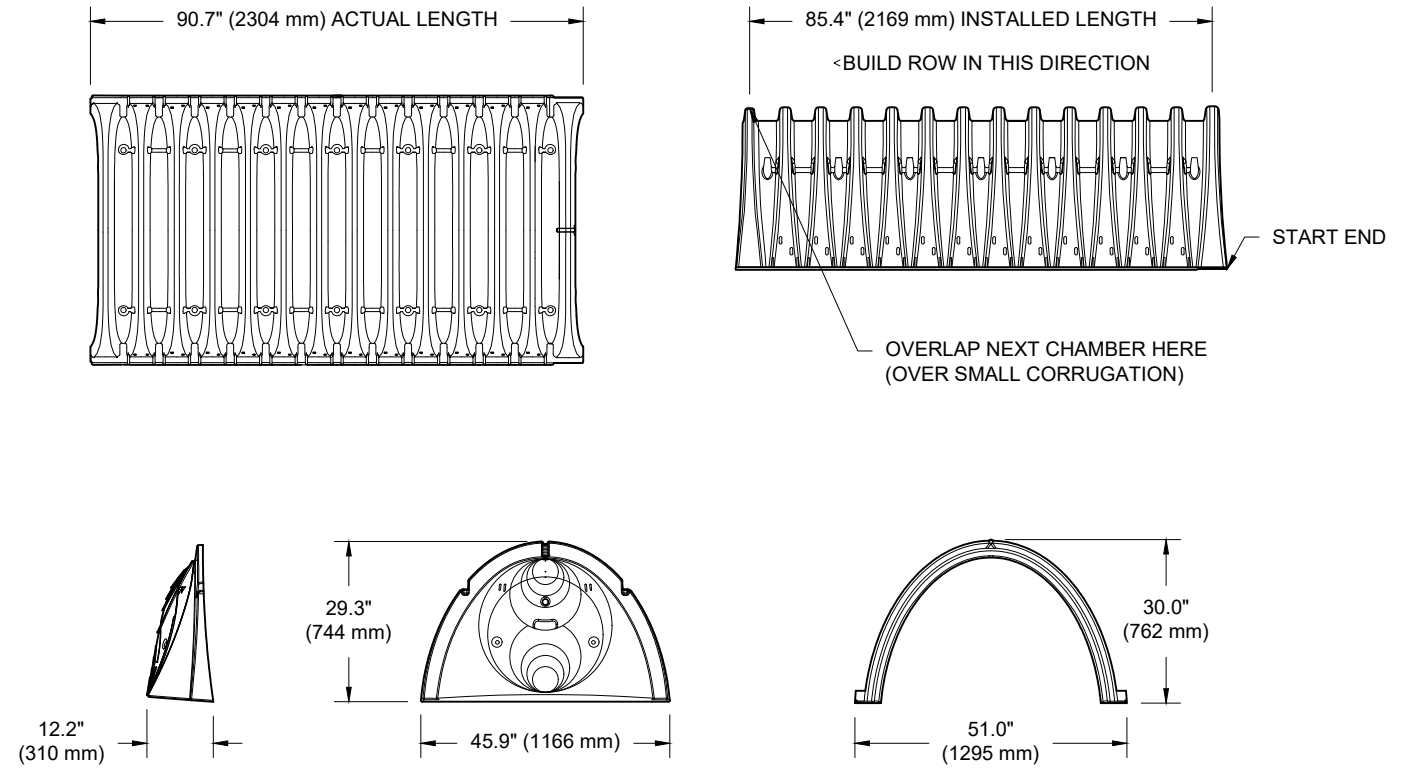

### NOMINAL CHAMBER SPECIFICATIONS

SIZE (W X H X INSTALLED LENGTH)	51.0" X 30.0" X 85.4"	(1295 mm X 762 mm X 2169 mm)
CHAMBER STORAGE	45.9 CUBIC FEET	(1.30 m <sup>3</sup> )
MINIMUM INSTALLED STORAGE*	74.9 CUBIC FEET	(2.12 m <sup>3</sup> )
WEIGHT	75.0 lbs.	(33.6 kg)

\*ASSUMES 6" (152 mm) STONE ABOVE, BELOW, AND BETWEEN CHAMBERS

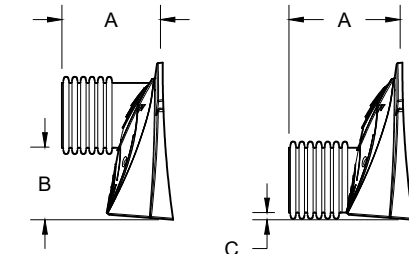

PRE-FAB STUBS AT BOTTOM OF END CAP FOR PART NUMBERS ENDING WITH "B"  
 PRE-FAB STUBS AT TOP OF END CAP FOR PART NUMBERS ENDING WITH "T"  
 PRE-CORED END CAPS END WITH "PC"

PART #	STUB	A	B	C
SC740EPE06T / SC740EPE06TPC	6" (150 mm)	10.9" (277 mm)	18.5" (470 mm)	---
SC740EPE06B / SC740EPE06BPC	---	---	---	0.5" (13 mm)
SC740EPE08T / SC740EPE08TPC	8" (200 mm)	12.2" (310 mm)	16.5" (419 mm)	---
SC740EPE08B / SC740EPE08BPC	---	---	---	0.6" (15 mm)
SC740EPE10T / SC740EPE10TPC	10" (250 mm)	13.4" (340 mm)	14.5" (368 mm)	---
SC740EPE10B / SC740EPE10BPC	---	---	---	0.7" (18 mm)
SC740EPE12T / SC740EPE12TPC	12" (300 mm)	14.7" (373 mm)	12.5" (318 mm)	---
SC740EPE12B / SC740EPE12BPC	---	---	---	1.2" (30 mm)
SC740EPE15T / SC740EPE15TPC	15" (375 mm)	18.4" (467 mm)	9.0" (229 mm)	---
SC740EPE15B / SC740EPE15BPC	---	---	---	1.3" (33 mm)
SC740EPE18T / SC740EPE18TPC	18" (450 mm)	19.7" (500 mm)	5.0" (127 mm)	---
SC740EPE18B / SC740EPE18BPC	---	---	---	1.6" (41 mm)
SC740EPE24B*	24" (600 mm)	18.5" (470 mm)	---	0.1" (3 mm)

ALL STUBS, EXCEPT FOR THE SC740EPE24B ARE PLACED AT BOTTOM OF END CAP SUCH THAT THE OUTSIDE DIAMETER OF THE STUB IS FLUSH WITH THE BOTTOM OF THE END CAP. FOR ADDITIONAL INFORMATION CONTACT STORMTECH AT 1-888-892-2694.

\* FOR THE SC740EPE24B THE 24" (600 mm) STUB LIES BELOW THE BOTTOM OF THE END CAP APPROXIMATELY 1.75" (44 mm). BACKFILL MATERIAL SHOULD BE REMOVED FROM BELOW THE N-12 STUB SO THAT THE FITTING SITS LEVEL.

NOTE: ALL DIMENSIONS ARE NOMINAL

HARD ROCK OTTAWA	
OTTAWA, ON.	
DATE: 06/12/20	DRAWN: RCT
PROJECT #: S188516	CHECKED: JMQ

DATE	DRWN	CHKD	DESCRIPTION

**StormTech**  
 Retention • Retention • Water Quality  
 520 CROMWELL AVENUE | ROCKY HILL | CT | 06067  
 860-529-8188 | 1888-892-2694 | WWW.STORMTECH.COM

**ADS**  
 ADVANCED DRAINAGE SYSTEMS, INC.  
 4640 TRUEMAN BLVD  
 HILLIARD, OH 43026



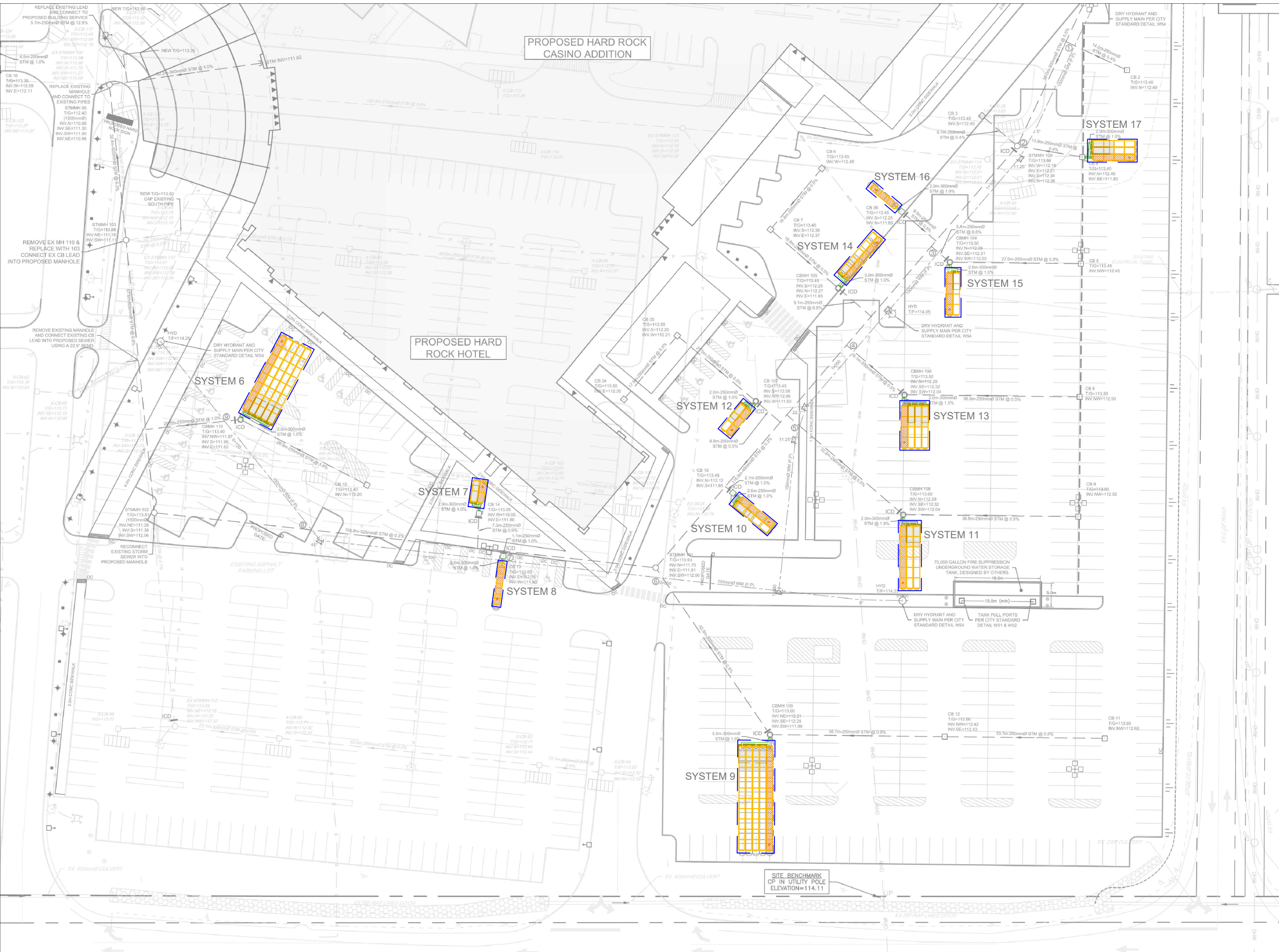

N.T.S.

TO BE READ IN CONJUNCTION WITH ALL C

### LEGEND

- PROPERTY LINE
- PROPOSED CURB
- DC --- PROPOSED DEPRES
- PROPOSED RETAI
- PROPOSED PRECA (O.P.S.D 603.020)
- TACTILE WALKING (TWS) PER CITY DE
- PROPOSED CAP
- PROPOSED CROSS
- PROPOSED PARKIN
- PROPOSED SANIT
- PROPOSED STORM
- PROPOSED FIRE S
- PROPOSED FRY H
- PROPOSED BUILD
- DIRECTION OF FLC
- PROPOSED CATCH
- ICD --- PROPOSED INLET
- PROPOSED CATCH
- PROPOSED UNDER GEOTEXTILE (REF)
- PROPOSED UNDER GEOTEXTILE (REF)
- PROPOSED LIGHT (REFER TO ELECT)
- DECORATIVE LAM (REFER TO ELECT)
- LIGHTING BOLLAR (REFER TO ELECT)
- CONCRETE BOLLA
- HYDRO TRANSFO (REFER TO ELECT)
- GENERATOR (REFER TO ELECT)
- ELECTRICAL MAN (REFER TO ELECT)
- EXISTING UTILITY
- WVC --- EXISTING WATER CHAMBER
- EXISTING HYDRA
- SAN MH --- EXISTING SANIT
- EXISTING SANIT
- STMMH --- EXISTING STORM
- CB --- EXISTING CATCH
- EXISTING INFILTR
- EXISTING GAS MA
- B --- EXISTING BELL LI
- EXISTING OVERL
- EXISTING HYDRO
- P --- EXISTING STREET
- LS --- EXISTING STREET
- EXISTING PARKIN

#### PIPE CROSSING TABLE

CROSSING	LOWER PIPE		HIGHER PIPE	
	WM	STM	WM	STM
1	150mm	250mm	111.35	112.3
2	150mm	250mm	111.25	112.3
3	150mm	250mm	111.15	112.2
4	150mm	250mm	111.30	112.2
5	150mm	250mm	111.30	112.1
6	150mm	300mm	111.60	112.0
7	150mm	300mm	111.25	111.9
8	150mm	625mm	111.20	111.5
9	150mm	250mm	111.00	111.8

#### 150mm FIRE SUPPRESSION WATERMAIN

STATION	ELEVATION	TOP OF WATERMAIN	DESCRIPTION
0+00.0	114.15	111.75	DRY HYDRA
0+09.7	114.30	111.90	5" HORIZONTAL DE
0+26.1	114.30	111.90	TEE CONNECTION WITH 150mm FIRE S
0+59.7	114.00	111.60	CROSSING STORM SEWER (C
0+84.5	113.65	111.25	CROSSING STORM SEWER (C
0+123.0	113.90	111.50	45" HORIZONTAL
0+125.9	113.75	111.20	CROSSING STORM SEWER (C
0+155.3	113.40	111.00	CROSSING STORM SEWER (C
0+176.7	114.15	111.75	DRY HYDRA

#### 150mm FIRE SUPPRESSION WATERMAIN

STATION	ELEVATION	TOP OF WATERMAIN	DESCRIPTION
1+00.0	114.30	111.90	TEE CONNECTION WITH 150mm FIRE S
1+031.9	113.70	111.30	11.25" HORIZONTAL
1+034.9	113.70	111.30	CROSSING STORM SEWER (C
1+039.0	113.70	111.30	22.5" HORIZONTAL
1+054.6	113.70	111.30	CROSSING STORM SEWER (C
1+065.9	113.95	111.55	DRY HYDRANT TEE (C
1+082.0	113.55	111.15	CROSSING STORM SEWER (C
1+108.1	113.65	111.25	11.25" HORIZONTAL
1+119.6	113.65	111.25	CROSSING STORM SEWER (C
1+134.5	113.75	111.35	CROSSING STORM SEWER (C
1+147.7	113.55	111.15	DRY HYDRA



PROPOSED HARD ROCK  
LIVE AUDITORIUM

SYSTEM 20

SYSTEM 19

SYSTEM 18

SCALE

DESIGN

FOR REVIEW ONLY

MJH

LOCATION  
4837 ALBION R



October 20, 2010

Subject: StormTech Isolator Row

To whom it may concern,

Isolator™ Row, which is a patented filtration type BMP manufactured by StormTech. The Isolator Row is covered under US Patent No.: US 6,991,734 B1.

1. a. Description:

The Isolator Row is a row or rows of StormTech thermoplastic chambers that are wrapped in filter fabric and installed below grade. Stormwater enters the chambers and must pass through the filter fabric media where sediments and other contaminants are filtered out as stormwater exits the Isolator Row through the fabric.

Some of the unique features of the Isolator Row that contribute to its effectiveness and practicality include:

- Vast filtration area – each SC-740 chamber has 27.8 square feet of filtration area through the bottom filter fabric
- Large sediment storage volume
- Entire bottom area accessible for cleaning without obstructions within the row
- A state-of-the-art structural design that meets AASHTO safety factors for both live loads and permanent dead loads

1. b. Applicable Sites:

The Isolator Row can be effectively used for essentially all developed sites. The most common applications are highly impervious sites such as paved parking areas, roads as well as developed sites that include grassy or other landscaped areas. It is not intended to be used for construction sediments.

1. c. Isolator Row Approvals:

The Isolator Row has been approved on a project by project basis for thousands of projects around the United States. Following are some examples:

- In Massachusetts, approvals for the State DEP requirement of 80% TSS removal on an annual load basis are issued at the Conservation Commission level, and the Isolator Row is commonly used to meet this criteria.
- In 2004 the Maine DEP approved the Isolator Row based on laboratory testing of 110 micron (US Silica OK-110) particle size
- Under the New Environmental Technology Evaluation program, the Ontario (Canada) Ministry of the Environment has evaluated the Isolator row and issued a Certificate of Technology Assessment

#### 1.d. Manufacturer History:

After many years developing and providing chamber systems for both septic and stormwater applications, StormTech owners formed StormTech, LLC in 2003 as a joint venture Company to focus exclusively on stormwater. All StormTech chambers are produced in the United States. As of this date, StormTech has millions of chambers installed, primarily for commercial applications within the United States, but installation locations also include Canada, Europe, Australia and the Middle East.

The Isolator Row was developed in 2003 initially as a maintenance feature, essentially to capture sediments that could otherwise accumulate in the open graded stone that surrounds the chambers. This open graded stone serves two roles; 1) to provide the important structural soil support of the soil–structure interaction system and 2) to provide open porosity to store stormwater. The Isolator Row was found to be so effective at capturing sediments that many regulators began allowing the Isolator Row as a sediment removal BMP for water quality.

StormTech engineering personnel include decades of experience in water quality. Our collective in-house engineering experience includes years with manufacturers of hydrodynamic separators, filter systems, consulting engineering and regulators. For performance evaluations relative to water quality, StormTech has gone to qualified outside researchers such as Vincent Neary, PhD, PE from Tennessee Tech University and Robert Roseen, PhD from the University of New Hampshire.

#### *History of Isolator Row Testing:*

- February 23, 2005 - Tennessee Tech University summarized laboratory testing on the Isolator Row in accordance with Maine DEP testing protocol. Tests demonstrated the following:
  - 95% TSS overall removal at 8.1 gpm/sqft for US Silica OK-110 (110 micron).
  - 80% captured on fabric, 15% captured in stone
- October 20, 2006 - Tennessee Tech University summarized laboratory testing on the Isolator Row in accordance with New Jersey Center for Advanced Technologies (NJCAT) testing protocol. Tests demonstrated the following:
  - 60% TSS Removal at 3.2 gpm/sqft for Sil-Co-Sil 106 with accumulated fines ( $D_{50} = 10$  microns)
  - 66% TSS Removal at 3.2 gpm/sqft for Sil-Co-Sil 106 ( $D_{50} = 22$  microns)
  - 71% TSS Removal at 3.2 gpm/sqft for Sil-Co-Sil 250 ( $D_{50} = 45$  microns)
  - 88% TSS Removal at 1.7 gpm/sqft for Sil-Co-Sil 250 ( $D_{50} = 45$  microns)
- August, 2007 – NJCAT summarized its third party evaluation of the Tennessee Tech test results and produced the “NJCAT Technology Verification Report StormTech Isolator Row”. Their verification is summarized as follows:
  - **Claim 1:** A StormTech® SC-740 Isolator™ Row, sized at a treatment rate of no more than 2.5 gpm/ft<sup>2</sup> of bottom area, using two layers of woven geotextile fabric under the base of the system and one layer of non-woven fabric wrapped over the top of the system and a mean event influent concentration of 270 mg/L (range of 139 – 361 mg/L) has been shown to have a TSS removal efficiency (measured as SSC) of at least 60% for SIL-CO-SIL 106, a manufactured silica product with an average particle size of 22 microns, in laboratory studies using simulated stormwater.
  - **Claim 2:** A StormTech® SC-740 Isolator™ Row, sized at a treatment rate of no more than 2.5 gpm/ft<sup>2</sup> of bottom area, using two layers of woven geotextile fabric

under the base of the system and one layer of non-woven fabric wrapped over the top of the system and a mean event influent concentration of 318 mg/L (range of 129 – 441 mg/L) has been shown to have a TSS removal efficiency (measured as SSC) of 84% for SIL-CO-SIL 250, a manufactured silica product with an average particle size of 45 microns, in laboratory studies using simulated stormwater.

- **Claim 3:** A StormTech® SC-740 Isolator™ Row, sized at a treatment rate of no more than 6.5 gpm/ft<sup>2</sup> of bottom area, using a single layer of woven geotextile fabric under the base of the system and one layer of non-woven fabric wrapped over the top of the system and a mean event influent concentration of 371 mg/L (range of 116 – 614 mg/L) has been shown to have a TSS removal efficiency (measured as SSC) of greater than 95% for OK-110, a manufactured silica product with an average particle size of 110 microns, in laboratory studies using simulated stormwater.
- June 2008 – The University of New Hampshire Stormwater Center released the Final Report on Field Verification Testing of the StormTech Isolator Row Treatment Unit. Testing consisted of determining the water quality performance for multiple stormwater pollutants in accordance with TARP Tier II protocol. As of the June report, data was recorded for 17 storm events.
  - TSS median removal efficiency – 80%
  - Petroleum Hydrocarbons median removal efficiency – 90%
  - Zinc median removal efficiency – 53%
  - Phosphorus median removal efficiency – 49%

1.e. Requested Use Level Designation Approval:

StormTech requests approval at the General Use Level (GUL). In support of this request, StormTech is providing test results from both laboratory and field studies by other that demonstrate that the “performance requirement” is met. However, we request an exception to the “certification requirement” of the application that specifies only an NJDEP or Washington DOE certification. StormTech has gone to qualified third parties for evaluation of the Isolator Row performance to provide regulators with an objective performance assessment.

StormTech has chosen to pursue field testing in accordance with TARP Tier 2 protocol and has not pursued Washington DOE approval. The NJDEP has delayed action on the Isolator Row and other BMPs while they reassess their performance and testing requirements which may or may not be relevant to MSD criteria. We therefore respectfully request that the MSD evaluate the Isolator Row based on MSD performance requirements.

I trust this provides sufficient information on the StormTech Isolator Row to enable your evaluation. However, should you have any questions or require additional information. Please do not hesitate to contact me or Susan McNamee directly.

Sincerely,

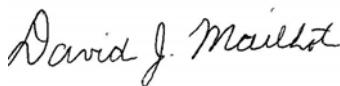

By: David J Mailhot, PE  
National Engineering Manager  
StormTech  
Phone: (860) 257-2150  
e-mail:dmailhot@stormtech.com



Susan McNamee  
Regional Product Manager  
StormTech  
Phone: (866) 405-9316  
e-mail:smcnamee@stormtech.com

# TEMPEST Product Submittal Package



**Date: April 24, 2020**

**Customer: Novatech**

**Contact: Conrad Stang**

**Location: Ottawa**

**Project Name: Hard Rock**



# Tempest HF ICD Sq Shop Drawing

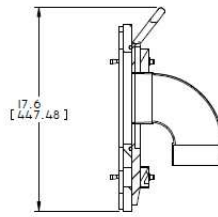
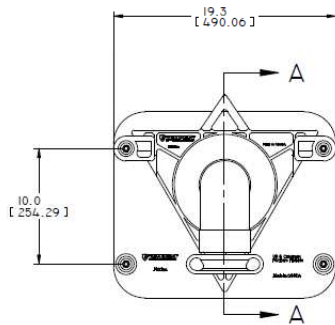
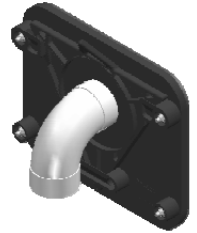
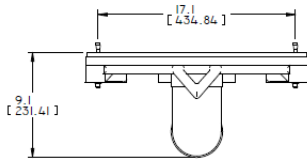

SECTION A-A



<b>TOLERANCES</b> UNLESS OTHERWISE SPECIFIED: FRACTIONS DECIMALS .125 ±.007 (0.004) in (0.127 ±.018 mm) .250 ±.007 (0.004) in (0.254 ±.018 mm) .375 ±.007 (0.004) in (0.381 ±.018 mm) .500 ±.007 (0.004) in (0.508 ±.018 mm) 1.000 ±.007 (0.004) in (1.016 ±.018 mm) 1.500 ±.007 (0.004) in (1.524 ±.018 mm) 2.000 ±.007 (0.004) in (2.032 ±.018 mm) 3.000 ±.007 (0.004) in (3.048 ±.018 mm) 4.000 ±.007 (0.004) in (4.064 ±.018 mm)		<b>IPEX TECHNOLOGIES INC.</b> PRODUCT DEVELOPMENT DEPARTMENT 2 BUCKLE UP DRIVE, SUITE 107 LAUREL SPRING, PENNSYLVANIA, DC 15085-1077 CHANDLER, PA. 15015-2020 WWW.IPEX.COM	
PROJECTION: FIRST ANGLE DIMENSIONS: in (mm)		TITLE: HF SQUARE CB ASSEMBLY	
DRAWN BY: H. M. MARTIN CHECKED BY:	DATE: 2011-07-25	SHEET: B OF: 1/3	SHEET: 1 OF: 1
REVISIONS:		DRAWING NUMBER: S01174-FA001R04	REV: 4



# Tempest LMF ICD Sq Shop Drawing

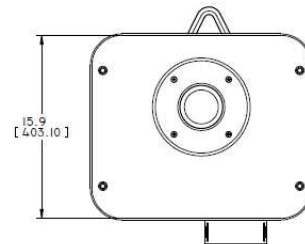
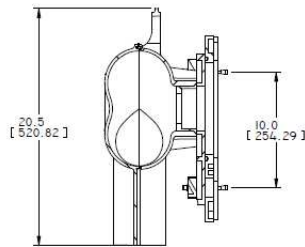
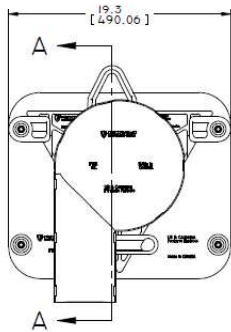
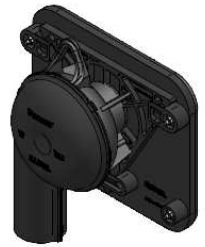
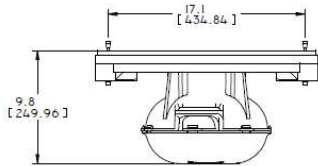

*Handwritten signature and blue circular stamp.*

SECTION A-A

<b>TOLERANCES:</b> Unspecified: ±0.005 HOLE: ±0.005 DIMS: ±0.005 HOLE: ±0.005 HOLE: ±0.005		<b>IPEX TECHNOLOGIES INC.</b> Product Development Engineering 1 Block for Commerce, Suite 101 4400 Ilex Road, Chesapeake, VA 23041 Chesapeake, VA 23041-7800 www.ipex.com	
TITLE: LMF SQUARE CB ASSEMBLY		SHEET: 1 OF 1	
DRAWN BY: M. MARTIN		DATE: 2011-07-27	
CHECKED BY:		DATE: 2011-07-27	
DESIGNED BY:		DRAWING NUMBER: 2011-07-27	
APPROVED BY:		REV: 3	



# Tempest HF ICD Rd Shop Drawing

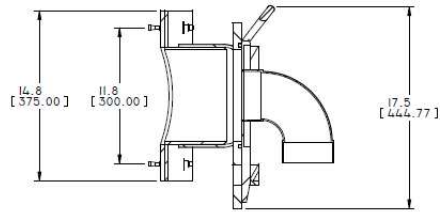
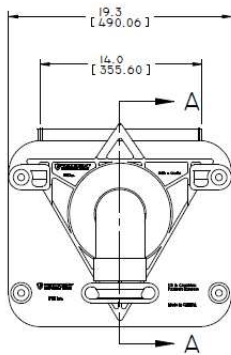
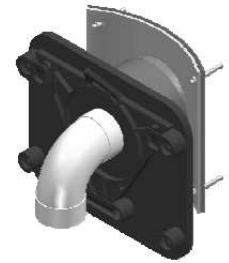
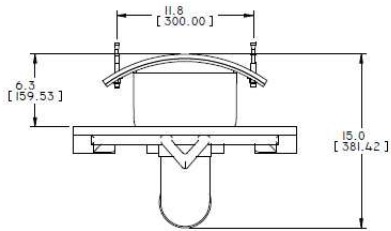

SECTION A-A

*Handwritten signature and date: 2/20/11*

IPEX TECHNOLOGIES INC. 10000 Highway 100, Suite 100 Dallas, TX 75243-2200 USA TEL: 972.992.1100 FAX: 972.992.1101 WWW.IPEX.COM		PROJECT NAME: HF ROUND CB ASSEMBLY PROJECT NO: 2011-07-25 DATE: 2011-07-25 DRAWN BY: M. McMartin CHECKED BY: S. Fagolros DATE: 2011-07-25		SHEET: 1 OF 1 REV: 5	
--	--	--	--	-------------------------	--



# Tempest LMF ICD Rd Shop Drawing

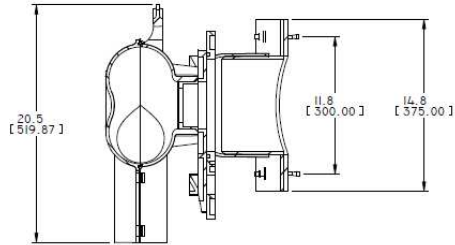
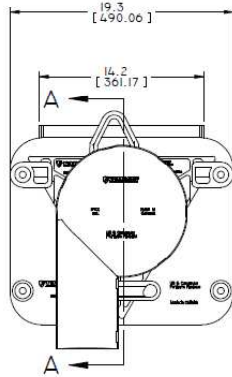
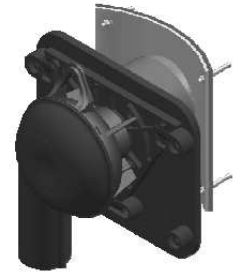
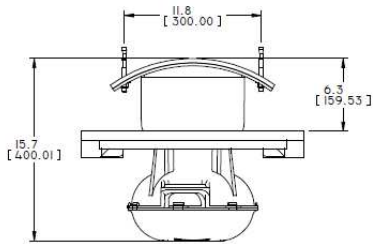

SECTION A-A



<b>TOLERANCES:</b> UNLESS OTHERWISE SPECIFIED: F.F. ±0.005 (0.0005) IN (0.127) MM F.XX ±0.002 (0.0002) IN (0.051) MM F.XXX ±0.001 (0.0001) IN (0.025) MM		<b>IPEX TECHNOLOGIES INC.</b> 10000 Highway 100, Suite 100 Columbia, SC 29208 USA	PROJECT DEVELOPMENT MANAGEMENT 3 PLAZA 100 Commerce Square Dr Columbia, SC 29208 USA	
FINISH: ANNEAL ANNEAL	PROJECTION (IN) (MM) (IN) (MM)		TITLE LMF ROUND CB ASSEMBLY	SHEET 9 / 18
DRAWN BY W. McFARTIN	DATE 2011-07-26	CHECKED BY G. J. S.	SHEET 1 OF 1	
VERIFIED BY	DATE 2011-07-26	DRAWING NUMBER 26H7L-F400-203	REV. 3	



## Tempest Plate ICD Rd Shop Drawing

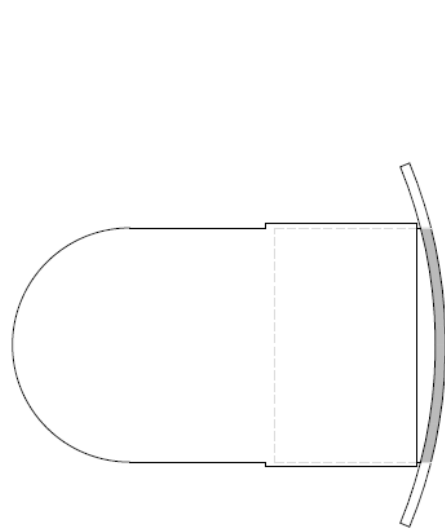

TOP VIEW

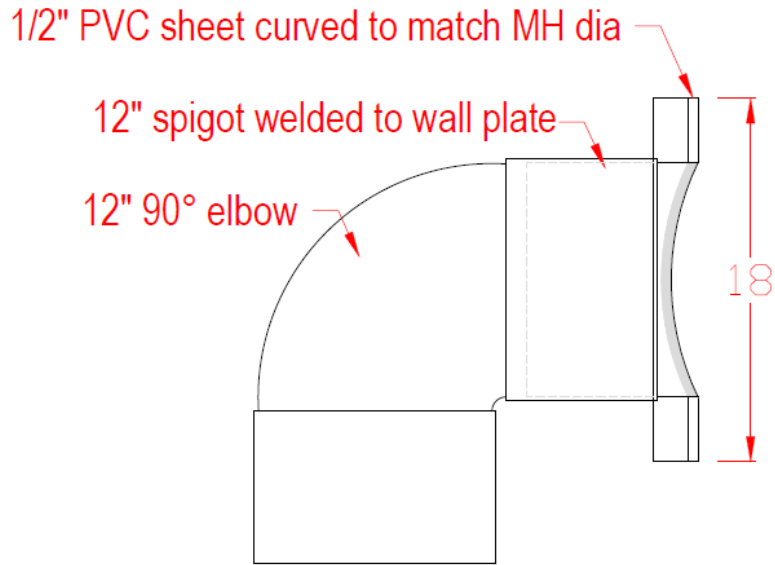

SIDE VIEW

ALL DIMENSIONS ARE IN INCHES UNLESS NOTED OTHERWISE

REV.	DATE	DESCRIPTION
CUSTOMER		
--		
DRAWING TITLE		
HF Plate ICD curved - 12" pipe		
DWG #	DATE	DRAWN BY
ON_170817-05D	8/17/2017	CR
SCALE	SHEET	REV
N.T.S.	1/1	--

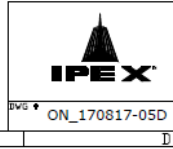

## **Square CB Installation Notes:**

1. Materials and tooling verification:
  - Tooling: impact drill, 3/8'' concrete bit, torque wrench for 9/16'' nut, hand hammer, level, and marker.
  - Material: (4) concrete anchor 3/8x3-1/2, (4) washers, (4) nuts
2. Use the mounting wall plate to locate and mark the hole (4) pattern on the catch basin wall. You should use a level to ensure that the plate is at the horizontal.
3. Use an impact drill with a 3/8'' concrete bit to make the four holes at a minimum of 1-1/2'' depth up to 2-1/2''. Clean the concrete dust from the holes.
4. Install the anchors (4) in the holes by using a hammer. Put the nuts on the top of the anchors to protect the threads when you will hit the anchors with the hammer. Remove the nuts on the ends of the anchors
5. Install the wall mounting plate on the anchors and screw the nut in place with a maximum torque of 40 N.m (30 lbf-ft). There should be no gap between the wall mounting plate and the catch basin wall.
6. From ground above using a reach bar, lower the device by hooking the end of the reach bar to the handle of the LMF device. Align the triangular plate portion into the mounting wall plate. Push down the device to be sure it has centered in to the wall mounting plate and has created a seal.



**Round CB Installation Notes:** (Refer to square install notes above for steps 1 , 3, & 4)

2. Use spigot catch basin wall plate to locate and mark the hole (4) pattern on the catch basin wall. You should use a level to ensure that the plate is at the horizontal.
5. Install the CB spigot wall plate on the anchors and screw the 4 nuts in place with a maximum torque of 40 N.m (30 lb-ft). There should be no gap between the CB spigot wall plate and the catch basin wall.
6. Apply solvent cement on the hub of the universal mounting plate and the spigot of the spigot CB wall plate. Slide the hub over the spigot. Make sure the universal mounting plate is at the horizontal and its hub is completely inserted onto the spigot. Normally, the corners of the universal mounting plate hub adapter should touch the catch basin wall.
7. From ground above using a reach bar, lower the ICD device by hooking the end of the reach bar to the handle of the ICD device. Align the triangular plate portion into the mounting wall plate. Push down the device to be sure it has centered into the mounting plate and has created a seal.



**CAUTION/WARNING/DISCLAIM:**

- Verify that the inlet(s) pipe(s) is not protruding into the catch basin. If it is, cut it back so that the inlet pipe is flush with the catch basin wall.
- Any required cement in the installation must be approved for PVC.
- The solvent cement should not be used below 0°C (32°F) or in a high humidity environment. Please refer to the IPEX solvent cement guide to confirm required curing times or attend the IPEX [Online Solvent Cement Training Course](#).
- Call your IPEX representative for more information or if you have any questions about our products.

## **IPEX TEMPEST Inlet Control Devices Technical Specification**

### **General**

Inlet control devices (ICD's) are designed to provide flow control at a specified rate for a given water head level and also provide odour and floatable control where specified. All ICD's will be IPEX Tempest or approved equal.

All devices shall be removable from a universal mounting plate. An operator from street level using only a T-bar with a hook will be able to retrieve the device while leaving the universal mounting plate secured to the catch basin wall face. The removal of the TEMPEST devices listed above must not require any unbolting or special manipulation or any special tools.

High Flow (HF) Sump devices will consist of a removable threaded cap which can be accessible from street level with out entry into the catchbasin (CB). The removal of the threaded cap shall not require any special tools other than the operator's hand.

ICD's must have no moving parts.

### **Materials**

ICD's are to be manufactured from Polyvinyl Chloride (PVC) or Polyurethane material, designed to be durable enough to withstand multiple freeze-thaw cycles and exposure to harsh elements.

The inner ring seal will be manufactured using a Buna or Nitrile material with hardness between Duro 50 and Duro 70.

The wall seal is to be comprised of a 3/8" thick Neoprene Closed Cell Sponge gasket which is attached to the back of the wall plate.

All hardware will be made from 304 stainless steel.

### **Dimensioning**

The Low Medium Flow (LMF), High Flow (HF) and the High Flow (HF) Sump shall allow for a minimum outlet pipe diameter of 200mm with a 600mm deep Catch Basin sump.

### **Installation**

Contractor shall be responsible for securing, supporting and connecting the ICD's to the existing influent pipe and catchbasin/manhole structure as specified and designed by the Engineer.





**Adjustable Accutrol Weir**

Tag: RD-100-A-ADJ

**Adjustable Flow Control  
for Roof Drains**

**ADJUSTABLE ACCUTROL(for Large Sump Roof Drains only)**

For more flexibility in controlling flow with heads deeper than 2", Watts Drainage offers the Adjustable Accutrol. The Adjustable Accutrol Weir is designed with a single parabolic opening that can be covered to restrict flow above 2" of head to less than 5 gpm per inch, up to 6" of head. To adjust the flow rate for depths over 2" of head, set the slot in the adjustable upper cone according to the flow rate required. Refer to Table 1 below.

Note: Flow rates are directly proportional to the amount of weir opening that is exposed.

**EXAMPLE:**

For example, if the adjustable upper cone is set to cover 1/2 of the weir opening, flow rates above 2" of head will be restricted to 2-1/2 gpm per inch of head.

Therefore, at 3" of head, the flow rate through the Accutrol Weir that has 1/2 the slot exposed will be:  
 [ 5 gpm(per inch of head) x 2 inches of head ] + 2-1/2 gpm(for the third inch of head) = 12-1/2 gpm.

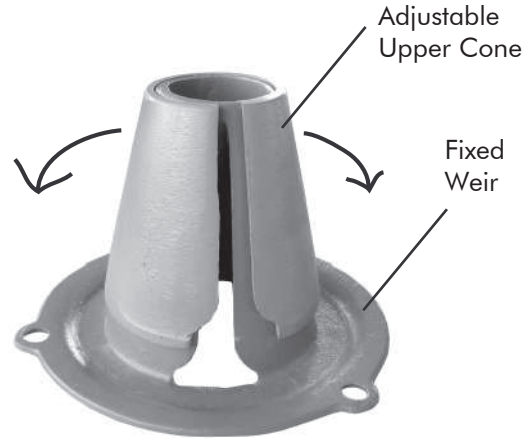
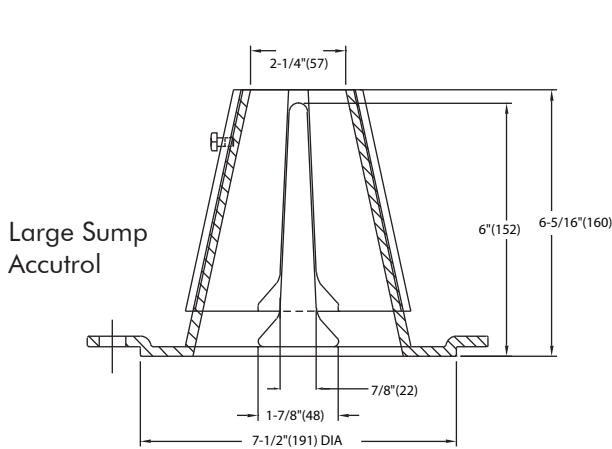

1/2 Weir Opening Exposed Shown Above

TABLE 1. Adjustable Accutrol Flow Rate Settings

Weir Opening Exposed	Head of Water					
	1"	2"	3"	4"	5"	6"
	Flow Rate (gallons per minute)					
Fully Exposed	5	10	15	20	25	30
3/4	5	10	13.75	17.5	21.25	25
1/2	5	10	12.5	15	17.5	20
1/4	5	10	11.25	12.5	13.75	15
Closed	5	10	10	10	10	10

Job Name \_\_\_\_\_ Contractor \_\_\_\_\_

Job Location \_\_\_\_\_ Contractor's P.O. No. \_\_\_\_\_

Engineer \_\_\_\_\_ Representative \_\_\_\_\_

WATTS Drainage reserves the right to modify or change product design or construction without prior notice and without incurring any obligation to make similar changes and modifications to products previously or subsequently sold. See your WATTS Drainage representative for any clarification. Dimensions are subject to manufacturing tolerances.



CANADA: 5435 North Service Road, Burlington, ON, L7L 5H7 TEL: 905-332-6718 TOLL-FREE: 1-888-208-8927 Website: www.wattsdrainage.ca





**CDS ESTIMATED NET ANNUAL SOLIDS LOAD REDUCTION  
BASED ON THE RATIONAL RAINFALL METHOD  
BASED ON A FINE PARTICLE SIZE DISTRIBUTION**



**Project Name:** Hard Rock Ottawa  
**Location:** Ottawa, ON  
**OGS #:** OGS

**Engineer:** NOVATECH  
**Contact:** Matthew Hrehoriak  
**Report Date:** 27-Oct-22

**Area** 0.14 ha  
**Weighted C** 0.90  
**CDS Model** 2015-4

**Rainfall Station #** 215  
**Particle Size Distribution** FINE  
**CDS Treatment Capacity** 20 l/s

<u>Rainfall Intensity<sup>1</sup></u> <u>(mm/hr)</u>	<u>Percent Rainfall Volume<sup>1</sup></u>	<u>Cumulative Rainfall Volume</u>	<u>Total Flowrate (l/s)</u>	<u>Treated Flowrate (l/s)</u>	<u>Operating Rate (%)</u>	<u>Removal Efficiency (%)</u>	<u>Incremental Removal (%)</u>
0.5	9.2%	9.2%	0.2	0.2	0.9	98.6	9.0
1.0	10.6%	19.8%	0.3	0.3	1.7	98.4	10.4
1.5	9.9%	29.7%	0.5	0.5	2.6	98.1	9.7
2.0	8.4%	38.1%	0.7	0.7	3.5	97.9	8.2
2.5	7.7%	45.8%	0.9	0.9	4.4	97.6	7.5
3.0	5.9%	51.7%	1.0	1.0	5.2	97.4	5.8
3.5	4.4%	56.1%	1.2	1.2	6.1	97.1	4.2
4.0	4.7%	60.7%	1.4	1.4	7.0	96.9	4.5
4.5	3.3%	64.0%	1.6	1.6	7.8	96.6	3.2
5.0	3.0%	67.1%	1.7	1.7	8.7	96.4	2.9
6.0	5.4%	72.4%	2.1	2.1	10.5	95.9	5.2
7.0	4.4%	76.8%	2.4	2.4	12.2	95.4	4.1
8.0	3.5%	80.3%	2.8	2.8	13.9	94.9	3.4
9.0	2.8%	83.2%	3.1	3.1	15.7	94.4	2.7
10.0	2.2%	85.3%	3.5	3.5	17.4	93.9	2.0
15.0	7.0%	92.3%	5.2	5.2	26.1	91.4	6.4
20.0	4.5%	96.9%	6.9	6.9	34.8	88.9	4.0
25.0	1.4%	98.3%	8.6	8.6	43.5	86.4	1.2
30.0	0.7%	99.0%	10.4	10.4	52.3	83.9	0.6
35.0	0.5%	99.5%	12.1	12.1	61.0	81.4	0.4
40.0	0.5%	100.0%	13.8	13.8	69.7	78.9	0.4
45.0	0.0%	100.0%	15.5	15.5	78.4	76.4	0.0
50.0	0.0%	100.0%	17.3	17.3	87.1	73.9	0.0

96.0

Removal Efficiency Adjustment<sup>2</sup> = 6.5%

**Predicted Net Annual Load Removal Efficiency = 89.5%**

**Predicted Annual Rainfall Treated = 100.0%**

1 - Based on 42 years of hourly rainfall data from Canadian Station 6105976, Ottawa ON

2 - Reduction due to use of 60-minute data for a site that has a time of concentration less than 30-minutes.

3 - CDS efficiency based on testing conducted at the University of Central Florida.

4 - CDS design and scaling based on original manufacturer model and product specifications.

## CDS PMSU2015-4-C DESIGN NOTES

THE STANDARD CDS PMSU2015-4-C CONFIGURATION IS SHOWN. ALTERNATE CONFIGURATIONS ARE AVAILABLE AND ARE LISTED BELOW. SOME CONFIGURATIONS MAY BE COMBINED TO SUIT SITE REQUIREMENTS.

### CONFIGURATION DESCRIPTION

- GRATED INLET ONLY (NO INLET PIPE)
- GRATED INLET WITH INLET PIPE OR PIPES
- CURB INLET ONLY (NO INLET PIPE)
- CURB INLET WITH INLET PIPE OR PIPES
- CUSTOMIZABLE SUMP DEPTH AVAILABLE
- ANTI-FLOTATION DESIGN AVAILABLE UPON REQUEST

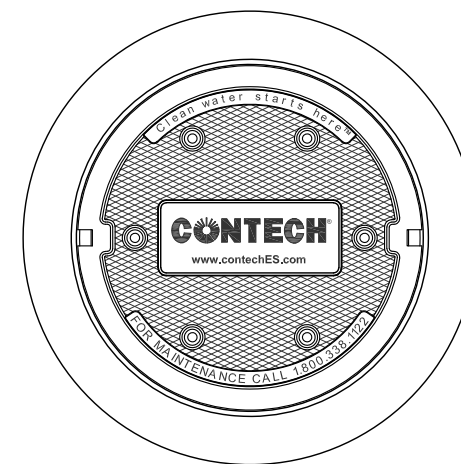
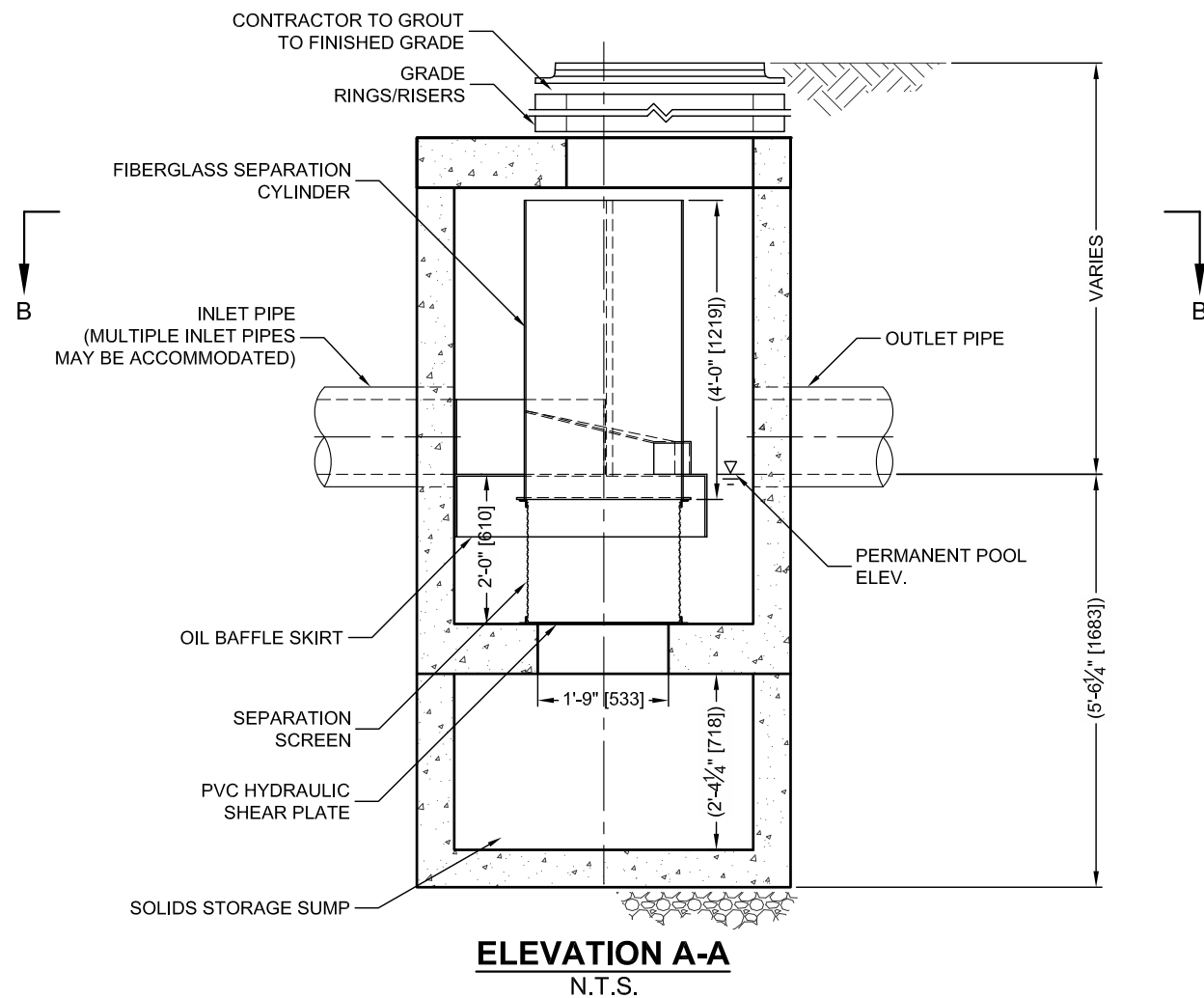
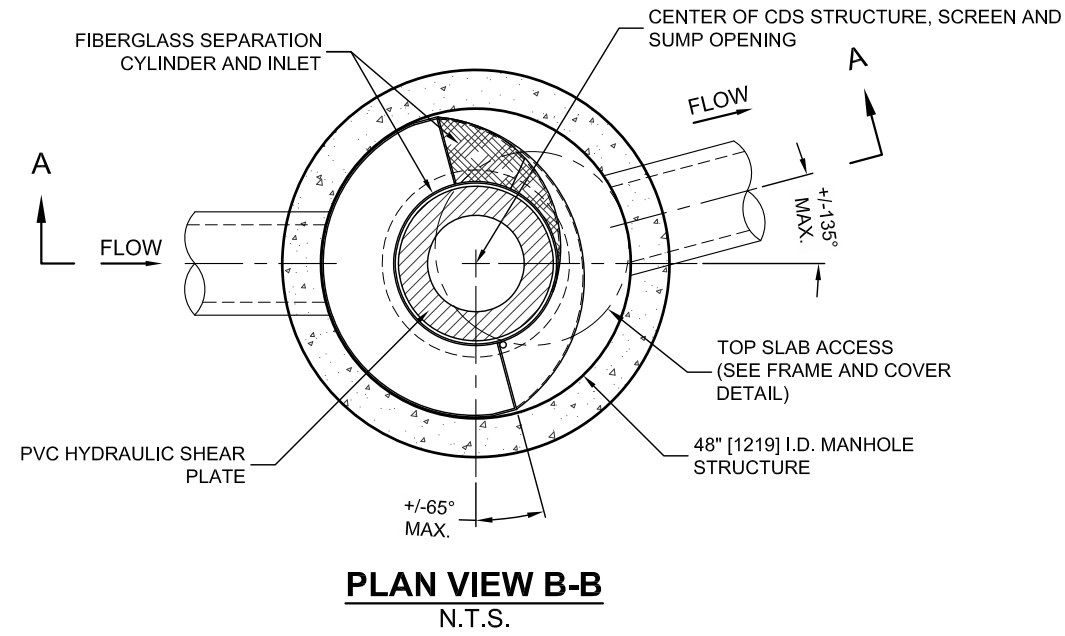

### SITE SPECIFIC DATA REQUIREMENTS

STRUCTURE ID				
WATER QUALITY FLOW RATE (CFS OR L/s)				*
PEAK FLOW RATE (CFS OR L/s)				*
RETURN PERIOD OF PEAK FLOW (YRS)				*
SCREEN APERTURE (2400 OR 4700)				*
PIPE DATA:	I.E.	MATERIAL	DIAMETER	
INLET PIPE 1	*	*	*	
INLET PIPE 2	*	*	*	
OUTLET PIPE	*	*	*	
RIM ELEVATION				*
ANTI-FLOTATION BALLAST	WIDTH	HEIGHT		
	*	*		
NOTES/SPECIAL REQUIREMENTS:				
* PER ENGINEER OF RECORD				

#### GENERAL NOTES

1. CONTECH TO PROVIDE ALL MATERIALS UNLESS NOTED OTHERWISE.
2. DIMENSIONS MARKED WITH ( ) ARE REFERENCE DIMENSIONS. ACTUAL DIMENSIONS MAY VARY.
3. FOR FABRICATION DRAWINGS WITH DETAILED STRUCTURE DIMENSIONS AND WEIGHTS, PLEASE CONTACT YOUR CONTECH ENGINEERED SOLUTIONS LLC REPRESENTATIVE. [www.contechES.com](http://www.contechES.com)
4. CDS WATER QUALITY STRUCTURE SHALL BE IN ACCORDANCE WITH ALL DESIGN DATA AND INFORMATION CONTAINED IN THIS DRAWING.
5. STRUCTURE SHALL MEET AASHTO HS20 AND CASTINGS SHALL MEET HS20 (AASHTO M 306) LOAD RATING, ASSUMING GROUNDWATER ELEVATION AT, OR BELOW, THE OUTLET PIPE INVERT ELEVATION. ENGINEER OF RECORD TO CONFIRM ACTUAL GROUNDWATER ELEVATION.
6. PVC HYDRAULIC SHEAR PLATE IS PLACED ON SHELF AT BOTTOM OF SCREEN CYLINDER. REMOVE AND REPLACE AS NECESSARY DURING MAINTENANCE CLEANING.

#### INSTALLATION NOTES

- A. ANY SUB-BASE, BACKFILL DEPTH, AND/OR ANTI-FLOTATION PROVISIONS ARE SITE-SPECIFIC DESIGN CONSIDERATIONS AND SHALL BE SPECIFIED BY ENGINEER OF RECORD.
- B. CONTRACTOR TO PROVIDE EQUIPMENT WITH SUFFICIENT LIFTING AND REACH CAPACITY TO LIFT AND SET THE CDS MANHOLE STRUCTURE (LIFTING CLUTCHES PROVIDED).
- C. CONTRACTOR TO ADD JOINT SEALANT BETWEEN ALL STRUCTURE SECTIONS, AND ASSEMBLE STRUCTURE.
- D. CONTRACTOR TO PROVIDE, INSTALL, AND GROUT PIPES. MATCH PIPE INVERTS WITH ELEVATIONS SHOWN.
- E. CONTRACTOR TO TAKE APPROPRIATE MEASURES TO ASSURE UNIT IS WATER TIGHT, HOLDING WATER TO FLOWLINE INVERT MINIMUM. IT IS SUGGESTED THAT ALL JOINTS BELOW PIPE INVERTS ARE GROUTED.

**CONTECH**  
ENGINEERED SOLUTIONS LLC

[www.contechES.com](http://www.contechES.com)  
9025 Centre Pointe Dr., Suite 400, West Chester, OH 45069  
800-338-1122 513-645-7000 513-645-7993 FAX

CDS PMSU2015-4-C  
INLINE CDS  
STANDARD DETAIL



THIS PRODUCT MAY BE PROTECTED BY ONE OR MORE OF THE FOLLOWING U.S. PATENTS: 6,788,848; 6,641,722; 6,511,502; 6,581,783; RELATED FOREIGN PATENTS, OR OTHER PATENT PENDING.

**re:** Permeameter Test Investigation  
Proposed Infiltration System  
Hard Rock Ottawa - 4837 Albion Road - Ottawa

**to:** Novatech Engineering - Mr. Lee Sheets - [l.sheets@novatech-eng.com](mailto:l.sheets@novatech-eng.com)

**cc:** A2S Consulting Engineers - Mr. Albert Celli - [albert@a2s.ca](mailto:albert@a2s.ca)

**date:** November 26, 2019

**file:** PG4315-MEMO.02

---

Further to your request, Paterson Group (Paterson) conducted a permeameter test investigation for the proposed infiltration system to be installed in conjunction with the proposed building expansion. The purpose of the investigation was to provide field saturated hydraulic conductivity values and estimated infiltration rates to be encountered within the subsoils below the proposed infiltration system at the aforementioned site. This memorandum report should be read in conjunction with Paterson Report PG4315-2 Revision 1 dated December 6, 2019.

## Proposed Project

It is our understanding that the proposed development will consist of a multi-storey building expansion. An associated parking garage, car parking areas, access lanes and landscaped areas are also anticipated for the expansion. Furthermore, it is understood that an underground infiltration system will be installed within the at-grade car parking areas of the proposed development with an approximate invert elevations ranging between 110.7 and 114.0 m.

## Field Investigation

### Field Program

The field program conducted by Paterson for the investigation was completed on November 8, 2019. At that time, 7 test hole locations were selected for permeameter testing at depths ranging from 0.4 and 0.9 m below existing ground surface. The test hole locations were selected by Paterson and distributed in a manner to avoid disturbing existing hard surfaces as well as taking into consideration existing site features. Previous geotechnical investigations were completed at the subject site by Paterson between November 9, 2017 and October 8, 2019. At that time, a total of 22 boreholes and 12 test pits were completed to a maximum depth of 22.5 and 1.9 m below existing grade, respectively. The test hole locations are presented on Drawing PG4315-1 - Test Hole Location Plan attached to this report.



## **In-Situ Testing**

Permeameter testing was conducted using a Pask (Constant Head Well) Permeameter. An 83 mm diameter hole was excavated using a Riverside/Bucket auger to a depth of 0.4 to 0.7 m and 0.7 to 0.9 m below existing ground surface at each location. All soil from the auger flights were visually inspected and initially classified on site. The permeameter reservoir was filled with water and inverted into the hole, ensuring it was relatively vertical and rests on the bottom of the hole. The water level of the reservoir was monitored at 1 minute intervals until the rate of fall of water in the permeameter reservoir reached equilibrium, known as *quasi "steady state"* flow rate. Quasi steady state flow can be considered to have been obtained after measuring 3 to 5 consecutive rate of fall readings with identical values. The values for the quasi steady state rate of fall were recorded for each location.

## **Field Observations**

### **Surface Conditions**

Currently the subject site is occupied by a two-storey building with a walk-out basement and horse track, as well as access lanes, parking and landscaped areas. The ground surface at the subject site is at similar grade to Albion Road and slopes down southward along Albion Road as well as eastward towards the horse track within the grass/treed area.

### **Subsurface Profile**

Generally, the subsurface profile at the test hole locations within the parking area of the development consists of topsoil or asphalt underlain by a crushed stone fill material with silty sand. The above noted material is primarily underlain by a silty sand and/or glacial till deposit. The glacial till deposit was observed to consist of a silty sand with gravel, cobbles and boulders. A stiff to very stiff silty clay was observed in select boreholes underlying the fill material. Practical refusal to DCPT was observed at depths ranging between 11.1 and 16.1 m below existing ground surface.

### **Groundwater**

Based on field observations such as moisture levels, colouring and consistency, the long-term groundwater level can be expected at a depth greater than 7 m bgs. Groundwater levels are subject to seasonal fluctuations and could vary at the time of construction.

## Permeameter Results

A total of 14 constant head Pask permeameter tests were conducted in softscaped areas within the existing parking area of the subject site. Permeameter testing was completed to verify the hydraulic conductivities and estimate the infiltration rates of the silty sand, glacial till and silty clay at the subject site. It is our understanding that the invert levels of the proposed infiltration system at the subject site will be installed within the silty sand, glacial till or silty clay deposit depending on location across the subject site. Preparation and testing of this investigation are in accordance with the Canadian Standards Association (CSA) B65-12 - Annex E. The hydraulic conductivity ( $K_{fs}$ ) values and estimated infiltration rates for each test hole location is presented in Table 1. It should be noted that permeameter testing could not be completed within the silty clay material due to the depth of the silty clay and limitations of the testing equipment.

Hydraulic conductivity values were determined using Engineering Technologies Canada (ETC) Ltd. reference tables provided in the most recent ETC Pask Permeameter User Guide dated March 2016. Infiltration rates have been determined based on approximate relationships between field saturated hydraulic conductivity, percolation time and infiltration rate. The above noted relationship has been provided by the Ontario Ministry of Municipal Affairs and Housing - Supplementary Guidelines to the Ontario Building Code, 1997 - SG-6 - Percolation Time and Soil Descriptions.

The field saturated hydraulic conductivity values that are calculated based upon Pask Permeameter testing are known to provide values that are less than or equal to half of the saturated hydraulic conductivity. The reduced hydraulic conductivity values are encountered due to air entrapment within the soils as shown by W.D. Reynolds (1993).

Test Hole ID	Depth bgs (m)	Material	Kfs (m/sec)	Infiltration Rate mm/hr
HA 1A	0.4	Silty Sand	1.3E-06	49
HA 1B	0.7	Silty Sand	3.8E-06	64
HA 2A	0.7	Silty Sand	6.9E-06	78
HA 2B	0.9	Silty Sand	6.3E-05	139
HA 3A	0.6	Silty Sand	3.8E-06	66
HA 3B	0.9	Silty Sand	1.5E-05	96
HA 4A	0.45	Glacial Till	6.9E-06	78
HA 4B	0.75	Glacial Till	3.4E-05	118
HA 5A	0.45	Glacial Till	2.1E-06	55
HA 5B	0.75	Glacial Till	5.3E-06	73
HA 6A	0.55	Silty Sand	3.1E-06	61
HA 6B	0.85	Silty Sand	4.4E-06	67
HA 7A	0.4	Glacial Till	3.2E-06	62
HA 7B	0.7	Glacial Till	2.1E-06	55

Based on the above testing, field saturated hydraulic conductivity values for the silty sand at the test hole locations ranged from  $1.3 \times 10^{-6}$  to  $6.3 \times 10^{-5}$  m/sec with estimated infiltration rates between 49 to 139 mm/hr. Field Saturated hydraulic conducting values for the glacial till ranged from  $2.1 \times 10^{-6}$  to  $3.4 \times 10^{-5}$  m/sec with estimated infiltration rates between 55 to 118 mm/hr. Permeameter testing was not completed within the silty clay as part of the current investigations. However, based upon previous experience at similar sites in the area with similar stratigraphy and typical published values, hydraulic conductivity values and infiltration rates for the silty clay has been estimated to range from  $1 \times 10^{-9}$  to  $1 \times 10^{-7}$  m/sec and 7 to 26 mm/hr, respectively.

Based on the permeameter test investigation at the test hole locations, we have provided estimated infiltration rates to be encountered within the subsoils of the proposed infiltration system at the aforementioned site. Our estimated infiltration rates are listed below and presented in Drawing PG4315-2 - Estimated Infiltration Rate Plan attached to the current report.

- Area 1 - Estimated infiltration rate of **110 mm/hr**
- Area 2 - Estimated infiltration rate of **90 mm/hr**
- Area 3 - Estimated infiltration rate of **60 mm/hr**
- Area 4 - Estimated infiltration rate of **25 mm/hr** if silty clay is encountered at the invert elevation, otherwise **60 mm/hr**

The values measured within the test holes are generally consistent with similar material Paterson has encountered on other sites and typical values for brown silty sand and glacial till. These values typically range from  $1 \times 10^{-6}$  to  $1 \times 10^{-4}$  m/sec for silty sand and  $1 \times 10^{-8}$  to  $1 \times 10^{-6}$  m/sec for glacial till due to the variability of the material encountered.

We trust that this information satisfies your requirements.

Best Regards,

**Paterson Group Inc.**



Nicholas Zulinski, P.Geo.



Michael S. Killam, P.Eng.

**Attachments**

- Drawing PG4315-2 - Estimated Infiltration Rate Plan

**Paterson Group Inc.**

**Head Office and Laboratory**  
154 Colonnade Road South  
Ottawa - Ontario - K2E 7J5  
Tel: (613) 226-7381 Fax: (613) 226-6344

**Northern Office and Laboratory**  
63 Gibson Street  
North Bay - Ontario - P1B 8Z4  
Tel: (705) 472-5331 Fax: (705) 472-2334

**St. Lawrence Office**  
993 Princess Street - Suite 100  
Kingston - Ontario - K7L 1H3  
Tel: (613) 542-7381

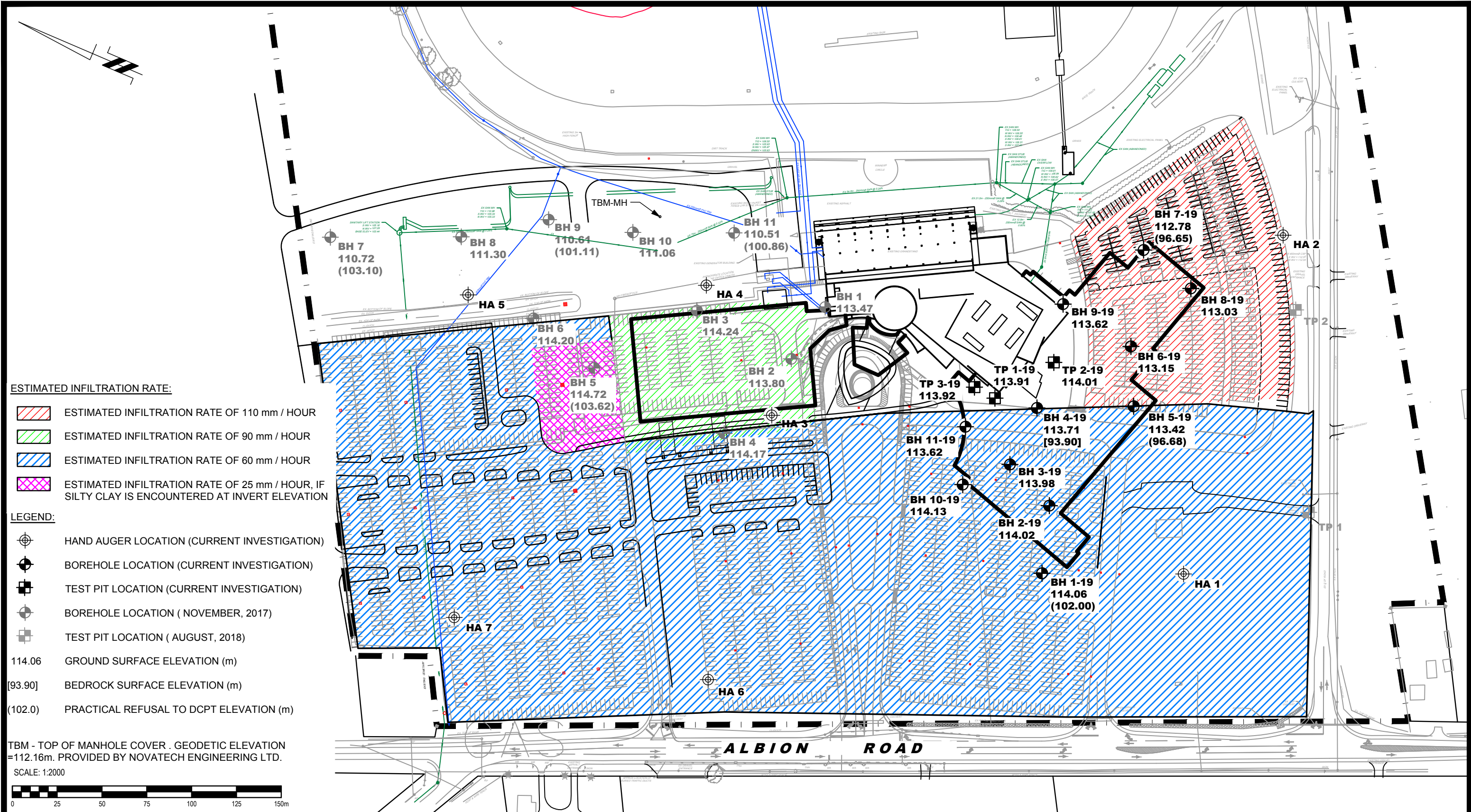

**ESTIMATED INFILTRATION RATE:**

- ESTIMATED INFILTRATION RATE OF 110 mm / HOUR
- ESTIMATED INFILTRATION RATE OF 90 mm / HOUR
- ESTIMATED INFILTRATION RATE OF 60 mm / HOUR
- ESTIMATED INFILTRATION RATE OF 25 mm / HOUR, IF SILTY CLAY IS ENCOUNTERED AT INVERT ELEVATION

**LEGEND:**

- HAND AUGER LOCATION (CURRENT INVESTIGATION)
- BOREHOLE LOCATION (CURRENT INVESTIGATION)
- TEST PIT LOCATION (CURRENT INVESTIGATION)
- BOREHOLE LOCATION ( NOVEMBER, 2017)
- TEST PIT LOCATION ( AUGUST, 2018)
- 114.06 GROUND SURFACE ELEVATION (m)
- [93.90] BEDROCK SURFACE ELEVATION (m)
- (102.0) PRACTICAL REFUSAL TO DCPT ELEVATION (m)

TBM - TOP OF MANHOLE COVER . GEODETIC ELEVATION =112.16m. PROVIDED BY NOVATECH ENGINEERING LTD.  
SCALE: 1:2000

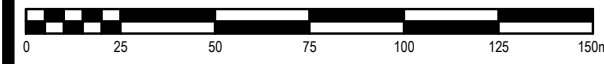

**patersongroup**  
consulting engineers

154 Colonnade Road South  
Ottawa, Ontario K2E 7J5  
Tel: (613) 226-7381 Fax: (613) 226-6344

NO.	REVISIONS	DATE	INITIAL

**HARD ROCK OTTAWA**

**PERMEAMETER TEST INVESTIGATION**

**PROPOSED BUILDING EXPANSION - 4837 ALBION ROAD**

OTTAWA, ONTARIO

**ESTIMATED INFILTRATION RATE PLAN**

Scale:	1:2000	Date:	11/2017
Drawn by:	YA	Report No.:	PG4315-1
Checked by:	NZ	Dwg. No.:	<b>PG4315-2</b>
Approved by:	DJG	Revision No.:	0

p:\laocad drawings\geotechnical\pg4315\pg4315-2-estimated infiltration rate plan.dwg

## **Appendix D**

### Stormwater Management Modeling

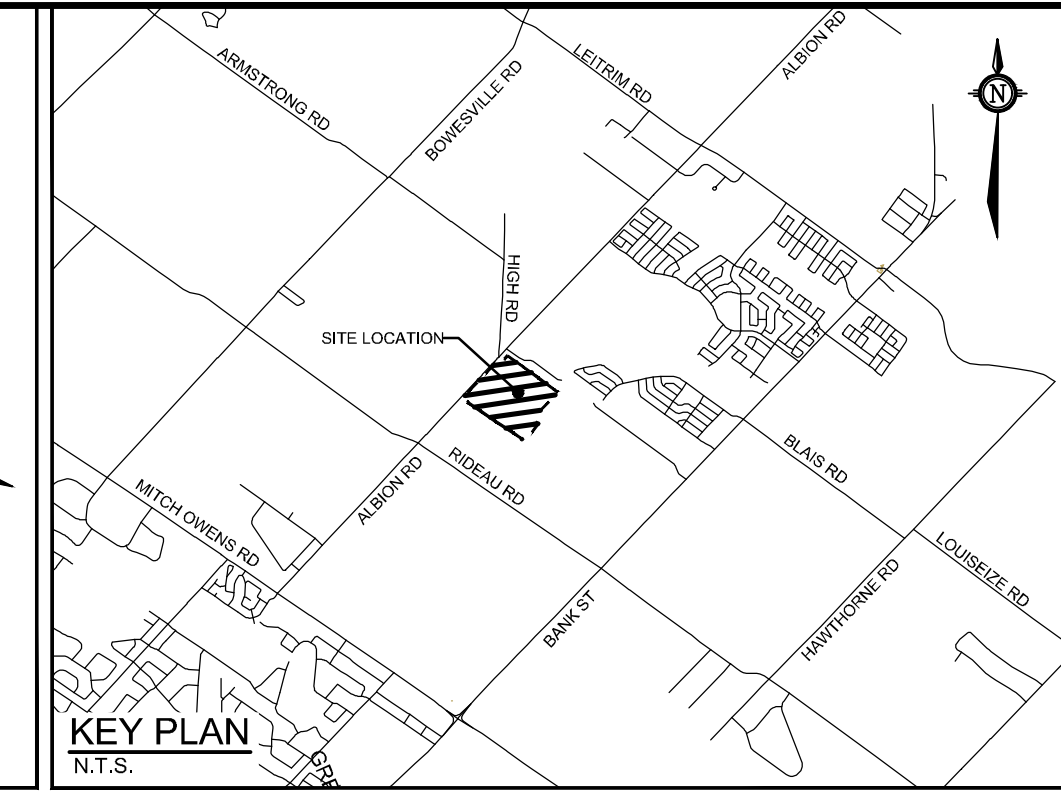

- LEGEND**
- PROPERTY LINE
  - PROPOSED STORM SEWER AND MANHOLE
  - DIRECTION OF FLOW
  - PROPOSED CATCHBASIN MANHOLE
  - PROPOSED CATCHBASIN
  - EXISTING STORM MANHOLE & SEWER
  - EXISTING CATCHBASIN
  - - - STORM SEWER DRAINAGE AREA BOUNDARY
  - DRAINAGE AREA (ha)
  - DRAINAGE AREA ID
  - RUNOFF COEFFICIENT
  - - - 100-YEAR PONDING LIMIT
  - - - 5-YEAR PONDING LIMIT
  - - - 2-YEAR PONDING LIMIT

**ROOF DRAIN TABLE:**

WATTS ACCUTROL RD-100-A-ADJ  
ROOF DRAIN TABLE

ROOF AREA	ROOF DRAIN ID	WEIR SETTING
R-1	RD-1 - RD-3	OPEN
R-2	RD-4 - RD-10	OPEN
R-3	RD-11 - RD-14	OPEN
R-4	RD-15 - RD-16	OPEN
R-5	RD-17 - RD-19	OPEN
R-6a	RD-20 - RD-23	OPEN
R-6b	RD-24 - RD-28	OPEN
R-7	RD-29 - RD-31	OPEN
R-8	RD-32	OPEN
R-9	RD-33A/B	OPEN
R-10	RD-34 - RD-37	OPEN
R-11	RD-38 - RD-41	OPEN
R-12a	RD-42 - RD-44	OPEN
R-12b	RD-45 - RD-47	OPEN
R-13	RD-48	OPEN
R-14	RD-49	OPEN

**INLET CONTROL DEVICE TABLE:**

CB / CBMH ID	IPEX ICD Type (model)	100-year Model Results
		Release Rate (L/s) Head (m)
EX-CB117	HF-77	14.08 1.44
EX-CB134	HF-85	19.43 1.81
EX-CB137	HF-137	47.28 1.58
EX-CB14	HF-130	57.55 2.89
EX-CB80	HF-110	31.55 1.69
EX-CB84	LMF-100	11.04 1.56
EX-CB72	LMF-100	11.58 1.7
EX-CB82	HF-202	96.31 1.39
EX-CB84	HF-118	35.5 1.66
EX-MH105	HF-199	122.26 2.39
EX-MH112	HF-218	116.78 1.5
PR-CB13	LMF-85	8.01 1.58
PR-CB14	LMF-85	7.88 1.61
PR-CB16/17	HF-202	97 1.41
PR-CB18	LMF-95	9.12 1.45
PR-CB29	LMF-85	4.36 0.49
PR-CB32	LMF-80	8.17 2.06
PR-CB36	LMF-80	6.05 1.34
PR-CB40	LMF-95	9.94 1.73
PR-CB41	LMF-85	7.5 1.47
PR-CBMH104	LMF-85	7.3 1.32
PR-CBMH105	LMF-85	7.51 1.4
PR-CBMH106	LMF-85	7.52 1.4
PR-CBMH107	LMF-85	7.88 1.62
PR-CBMH108	LMF-85	7.75 1.49
PR-CBMH109	LMF-90	9.44 1.6
PR-CBMH110	LMF-85	8.47 1.79
PR-CBMH111	LMF-105	14.4 1.95
PR-CBMH112	LMF-105	14.7 2.03
PR-CBMH114	LMF-95	10.77 2.02
PR-CBMH115	LMF-95	10.47 1.94
PR-CBMH118	HF-130	54.22 1.64
PR-MH100	LMF-95	8.74 1.42
PR-TD02	HF-130	35.43 1.13

\*3-hour Chicago Storm.  
\*IPEX ICD's sized based on 100-year model results.

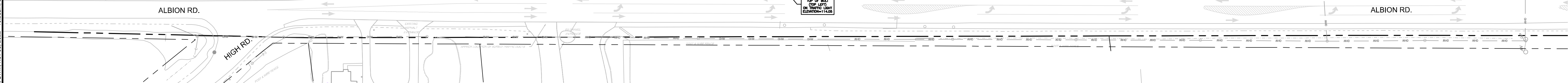
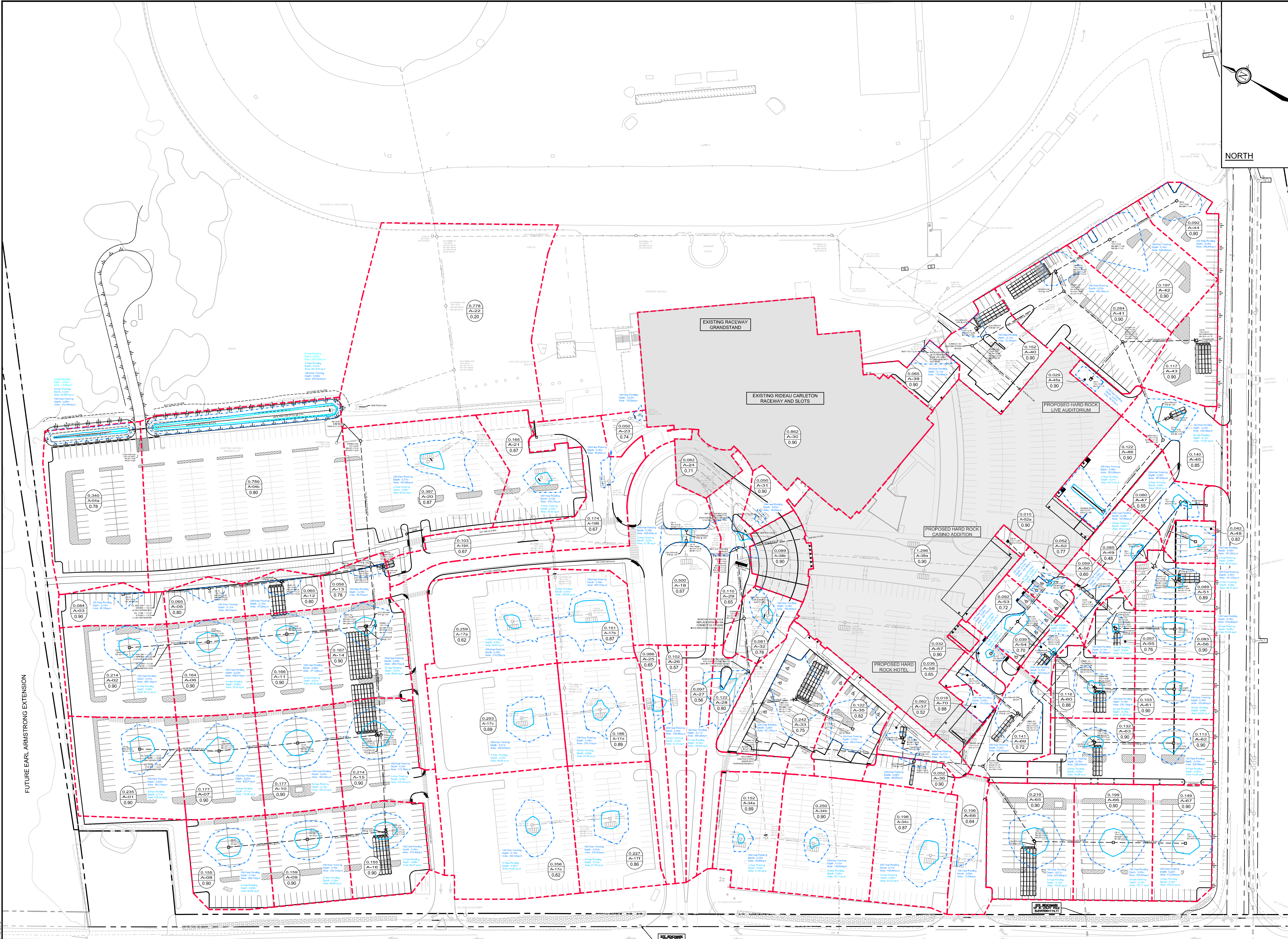

NOTE:  
THE POSITION OF ALL POLE LINES, CONDUITS, WATERMANS, SEWERS AND OTHER UNDERGROUND AND OVERGROUND UTILITIES AND STRUCTURES IS NOT NECESSARILY SHOWN ON THE CONTRACT DRAWINGS, AND WHERE SHOWN, THE ACCURACY OF THE POSITION OF SUCH UTILITIES AND STRUCTURES IS NOT GUARANTEED. BEFORE STARTING WORK, DETERMINE THE EXACT LOCATION OF ALL SUCH UTILITIES AND STRUCTURES AND ASSUME ALL LIABILITY FOR DAMAGE TO THEM.

**NOT FOR CONSTRUCTION**

No.	REVISION	DATE	BY
3	REVISED PER CITY COMMENTS	NOV 07/22	MJH
2	REVISED PER CITY COMMENTS	APRIL 24/20	CJR
1	ISSUED FOR SITE PLAN APPROVAL	NOV 2019	CJR

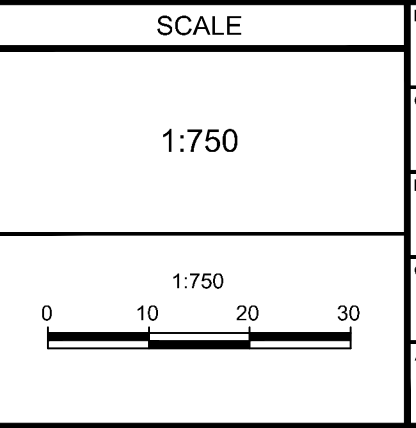

FOR REVIEW ONLY

RESR MJH  
CHECKED CJR  
DRAWN MJH  
CHECKED CJR  
APPROVED JLS

NOV 7/22  
PROVINCE OF ONTARIO

**NOVATECH**  
Engineers, Planners & Landscape Architects  
Suite 200, 240 Michael Copland Drive  
Ottawa, Ontario, Canada K2M 1P6  
Telephone: (613) 254-9643  
Facsimile: (613) 254-5867  
Website: www.novatech-eng.com

LOCATION  
4837 ALBION ROAD, CITY OF OTTAWA  
HARD ROCK OTTAWA

DRAWING NAME  
**STORMWATER MANAGEMENT  
DRAINAGE AREA PLAN**

PROJECT NO.: 116111  
REV # 3  
DRAWING NO.: 116111-SWM

4837 Albion Road - Hard Rock Ottawa (116111)  
PCSWMM Model Schematics - Existing

Overall Model Schematic



Date: 2020-04-23

M:\2016\116111\DATA\Calculations\Sewer Calcs\SWMM\PCSWMM\116111-PCSWMM Model Schematics - Existing.docx

4837 Albion Road - Hard Rock Ottawa (116111)  
PCSWMM Model Schematics - Existing

Subcatchments and Flow Paths

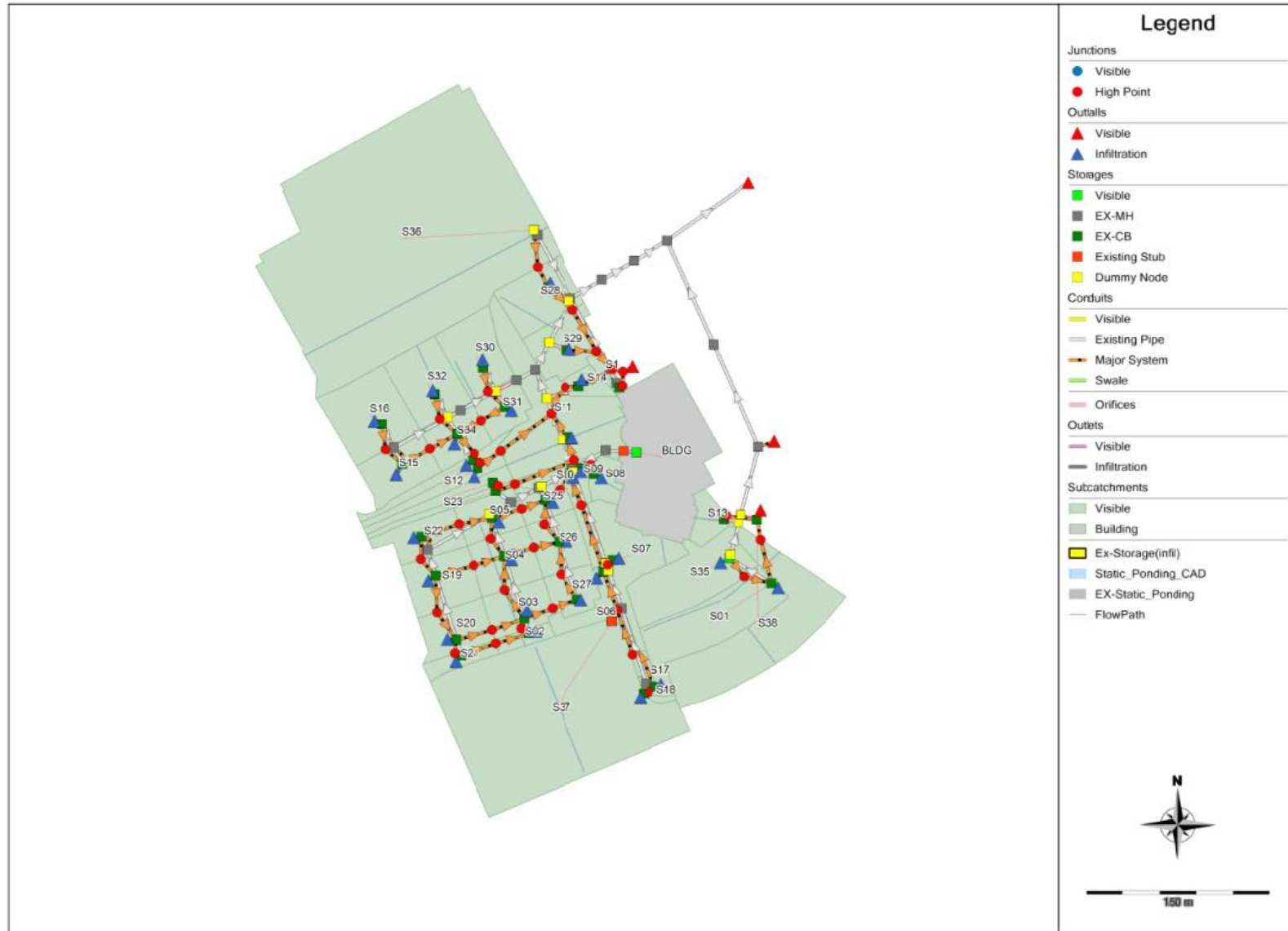

Date: 2020-04-23

M:\2016\116111\DATA\Calculations\Sewer Calcs\SWMM\PCSWMM\116111-PCSWMM Model Schematics - Existing.docx



4837 Albion Road - Hard Rock Ottawa (116111)  
 PCSWMM Model Schematics - Existing

Manholes and Outfalls

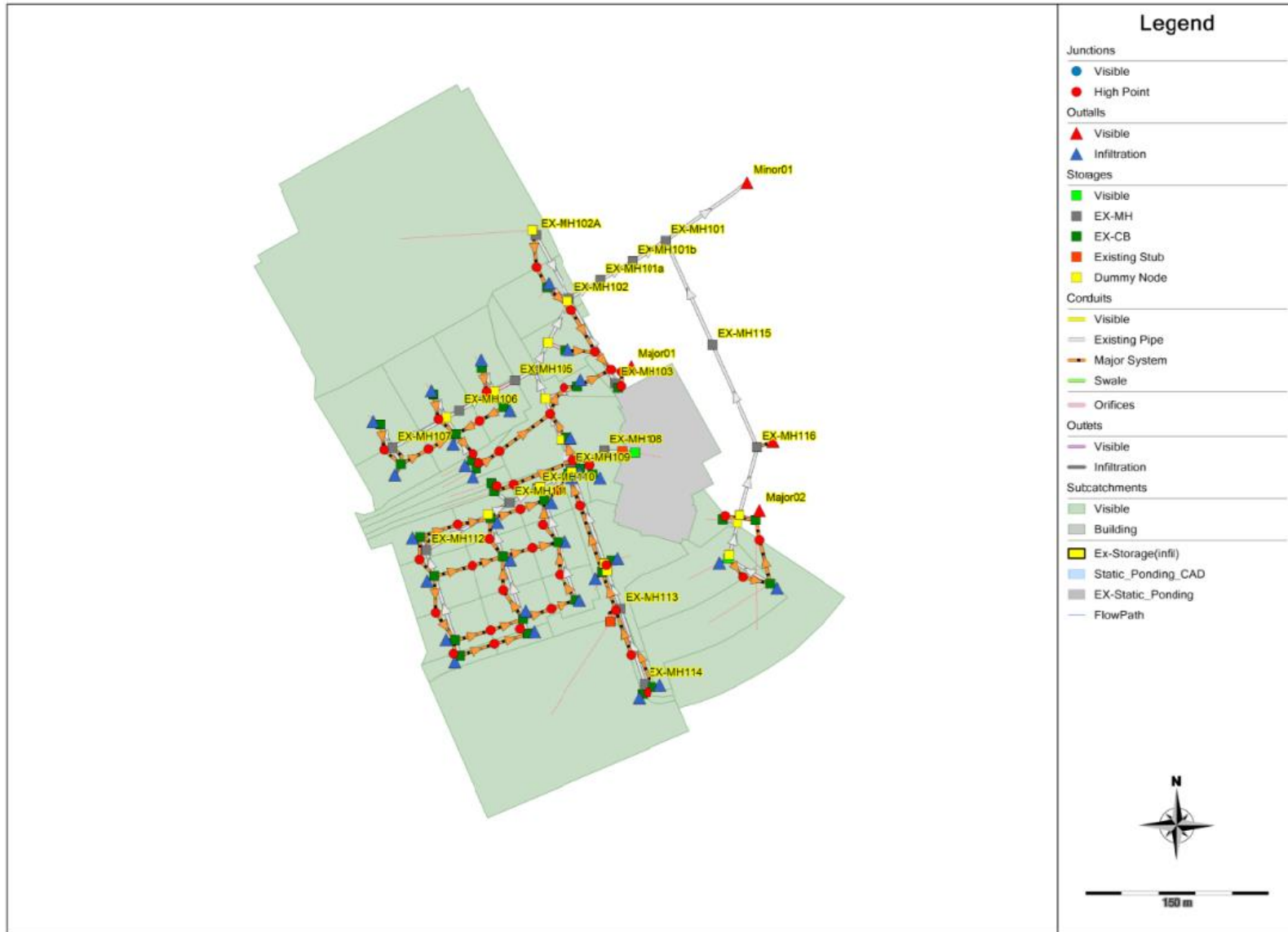

Date: 2020-04-23

M:\2016\116111\DATA\Calculations\Sewer Calcs\SWM\PCSWMM\116111-PCSWMM Model Schematics - Existing.docx

4837 Albion Road - Hard Rock Ottawa (116111)  
 PCSWMM Model Schematics - Existing

Catchbasins

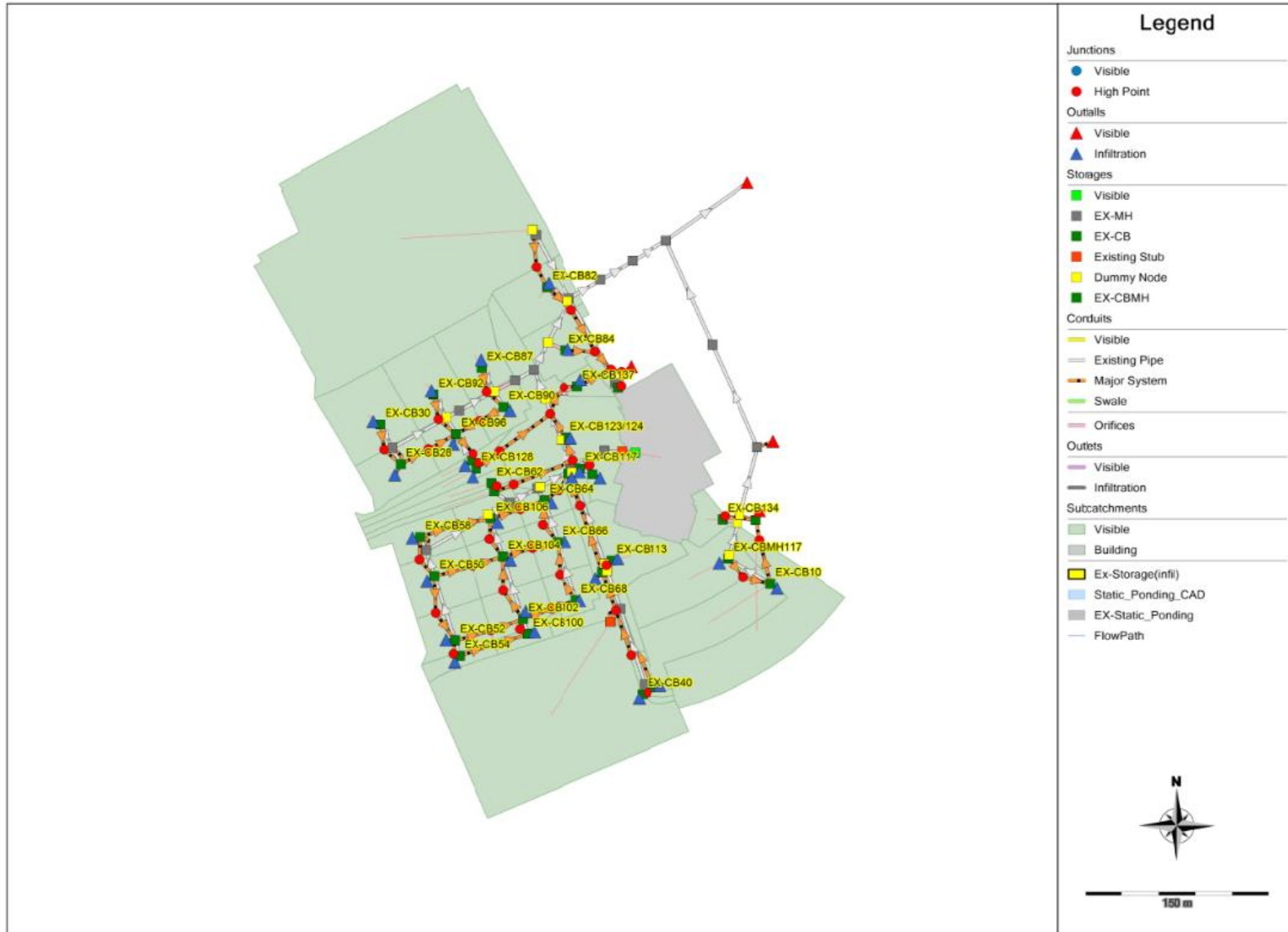

Date: 2020-04-23

M:\2016\116111\DATA\Calculations\Sewer Calcs\SWMM\PCSWMM\116111-PCSWMM Model Schematics - Existing.docx

4837 Albion Road - Hard Rock Ottawa (116111)  
 Subcatchment Parameters - Existing Conditions



Area ID	Catchment Area (ha)	Runoff Coefficient	Percent Impervious (%)	Zero Impervious (%)	Equivalent Width (m)	Flow Length (m)	Average Slope (%)
BLDG	0.864	0.90	100	100	66.5	130.0	1.5
S01	0.450	0.90	100	0	162.0	27.8	1.5
S02	0.060	0.90	100	0	120.0	5.0	1.5
S03	0.180	0.90	100	0	180.0	10.0	1.5
S04	0.220	0.90	100	0	200.0	11.0	1.5
S05	0.170	0.90	100	0	188.9	9.0	1.5
S06	0.210	0.90	100	0	350.0	6.0	1.5
S07	0.300	0.90	100	0	282.3	10.6	1.5
S08	0.090	0.90	100	0	90.0	10.0	1.5
S09	0.040	0.90	100	0	80.0	5.0	1.5
S1	0.040	0.90	100	0	4.0	100.0	1.5
S10	0.080	0.90	100	0	88.9	9.0	1.5
S11	0.700	0.90	100	0	145.8	48.0	1.5
S12	0.100	0.90	100	0	200.0	5.0	1.5
S13	0.100	0.90	100	0	40.0	25.0	1.5
S14	0.090	0.90	100	0	52.9	17.0	1.5
S15	0.230	0.90	100	0	115.0	20.0	1.5
S16	0.380	0.62	60	0	152.0	25.0	1.5
S17	0.030	0.90	100	0	60.0	5.0	1.5
S18	0.030	0.90	100	0	60.0	5.0	1.5
S19	0.250	0.90	100	0	192.3	13.0	1.5
S20	0.200	0.90	100	0	181.8	11.0	1.5
S21	0.080	0.90	100	0	160.0	5.0	1.5
S22	0.190	0.90	100	0	190.0	10.0	1.5
S23	0.070	0.90	100	0	140.0	5.0	1.5
S24	0.110	0.90	100	0	220.0	5.0	1.5
S25	0.110	0.90	100	0	220.0	5.0	1.5
S26	0.190	0.90	100	0	190.0	10.0	1.5
S27	0.140	0.90	100	0	200.0	7.0	1.5
S28	0.270	0.90	100	0	100.0	27.0	1.5
S29	0.230	0.90	100	0	95.8	24.0	1.5
S30	0.280	0.62	60	0	112.0	25.0	1.5
S31	0.140	0.90	100	0	70.0	20.0	1.5
S32	0.290	0.62	60	0	116.0	25.0	1.5
S33	0.100	0.90	100	0	200.0	5.0	1.5
S34	0.180	0.90	100	0	90.0	20.0	1.5
S35	0.420	0.90	100	0	165.5	25.4	1.5
S36	3.520	0.80	86	0	167.6	210.0	1.5
S37	1.910	0.34	20	0	176.9	108.0	1.5
S38	0.740	0.65	65	0	234.6	31.5	1.5
<b>Total</b>	<b>13.78</b>	<b>0.76</b>	<b>81</b>	-	-	-	-

CB / CBMH ID	STM ID	Drainage Area (ha)	Elevations (m)			Depths (m)			Provided Storage (m <sup>3</sup> )		
			Invert	RIM	Ponding	CB	Ponding	Total	UG	Surface <sup>1</sup>	Total
EX-CB10	S01	0.45	111.51	112.61	112.77	1.10	0.16	1.26	6.8	44.4	51.2
EX-CB100	S02	0.06	112.77	113.72	113.95	0.95	0.23	1.18	6.8	0.0	6.8
EX-CB102	S03	0.18	112.69	113.63	113.89	0.94	0.26	1.20	6.8	63.4	70.2
EX-CB104	S04	0.22	112.40	113.67	114.06	1.27	0.39	1.66	6.8	263.4	270.2
EX-CB106	S05	0.17	112.31	113.71	114.00	1.40	0.29	1.69	6.8	111.2	118.0
EX-CB110	S06	0.21	112.00	113.24	113.50	1.24	0.26	1.50	6.8	72.3	79.1
EX-CB113	S07	0.30	112.00	113.26	113.50	1.26	0.24	1.50	6.8	66.8	73.6
EX-CB116	S08	0.09	112.99	113.42	113.61	0.43	0.19	0.62	6.8	37.2	44.0
EX-CB117	S09	0.04	112.09	113.45	113.61	1.36	0.16	1.52	6.8	31.3	38.1
EX-CB121	S10	0.08	112.15	113.41	113.61	1.26	0.20	1.46	6.8	39.2	46.0
EX-CB123/124	S11	0.70	111.80	113.36	113.61	1.56	0.25	1.81	13.6	48.9	62.5
EX-CB128	S12	0.10	112.51	113.71	113.96	1.20	0.25	1.45	6.8	37.3	44.1
EX-CB132	S38	0.74	108.88	111.31	112.61	2.43	1.30	3.73	-	0.0	0.0
EX-CB134	S13	0.10	111.60	113.36	113.51	1.76	0.15	1.91	-	7.9	7.9
EX-CB137	S14	0.09	112.00	113.41	113.60	1.41	0.19	1.60	6.8	9.5	16.3
EX-CB28	S15	0.23	112.43	113.65	114.00	1.22	0.35	1.57	6.8	230.3	237.1
EX-CB30	S16	0.38	112.50	113.69	114.00	1.19	0.31	1.50	6.8	168.9	175.7
EX-CB38	S17	0.03	112.86	113.63	113.90	0.77	0.27	1.04	6.8	60.2	67.0
EX-CB40	S18	0.03	112.92	113.64	113.90	0.72	0.26	0.98	6.8	58.0	64.8
EX-CB50	S19	0.25	112.32	113.71	114.00	1.39	0.29	1.68	6.8	164.2	171.0
EX-CB52	S20	0.20	112.44	113.71	113.98	1.27	0.27	1.54	6.8	149.2	156.0
EX-CB54	S21	0.08	112.52	113.83	113.83	1.31	0.00	1.31	6.8	0.0	6.8
EX-CB58	S22	0.19	112.44	113.73	114.00	1.29	0.27	1.56	6.8	118.8	125.6
EX-CB60	S23	0.07	112.15	113.73	113.96	1.58	0.23	1.81	-	36.6	36.6
EX-CB62	S24	0.11	112.64	113.76	113.96	1.12	0.20	1.32	-	31.8	31.8
EX-CB64	S25	0.11	112.10	113.73	113.98	1.63	0.25	1.88	6.8	86.5	93.3
EX-CB66	S26	0.19	112.37	113.66	114.04	1.29	0.38	1.67	6.8	225.8	232.6
EX-CB68	S27	0.14	112.57	113.72	114.00	1.15	0.28	1.43	6.8	102.1	108.9
EX-CB82	S28	0.27	112.62	113.84	114.05	1.22	0.21	1.43	6.8	78.7	85.5
EX-CB84	S29	0.23	112.12	113.65	114.01	1.53	0.36	1.89	6.8	156.5	163.3
EX-CB87	S30	0.28	112.50	113.68	113.95	1.18	0.27	1.45	6.8	124.3	131.1
EX-CB90	S31	0.14	112.51	113.79	113.95	1.28	0.16	1.44	6.8	91.5	98.3
EX-CB92	S32	0.29	112.49	113.67	113.95	1.18	0.28	1.46	6.8	110.7	117.5
EX-CB95	S33	0.10	112.45	113.67	113.96	1.22	0.29	1.51	6.8	43.3	50.1
EX-CB96	S34	0.18	112.22	113.62	113.95	1.40	0.33	1.73	6.8	211.8	218.6
EX-CBMH117	S35	0.42	111.26	112.74	112.85	1.48	0.11	1.59	6.8	39.3	46.1
EX-MH102Aa	S36	3.52	112.42	114.16	114.31	1.74	0.15	1.89	6.8	0.0	6.8
<b>TOTAL</b>		<b>10.97</b>							<b>231.2</b>	<b>3121.3</b>	<b>3352.5</b>

<sup>1</sup> Based on existing 1:1000 topographic mapping product from the City of Ottawa survey.

<sup>2</sup> Based on storage indicated in 1999 Stormwater Management Report (Trow, 1999); 10x chambers providing total of 6.8 m<sup>3</sup>.

4837 Albion Road - Hard Rock Ottawa (116111)  
 Underground and Surface Storage Provided - Existing Conditions



Storage Provided by StormTech STC-740 Chambers		System Length (m) <sup>1</sup>	
Number	Storage (m <sup>3</sup> ) <sup>1</sup>	1 Row	2 Rows
1	2.1	3.27	3.27
2	4.2	5.44	3.27
3	6.3	7.61	5.44
4	8.4	9.78	5.44
5	10.6	11.95	7.61
6	12.7	14.12	7.61
7	14.8	16.29	9.78
8	16.9	18.46	9.78
9	19.0	20.63	11.95
10	21.2	22.80	11.95
11	23.3	24.97	14.12
12	25.4	27.14	14.12
13	27.5	29.31	16.29
14	29.6	31.48	16.29
15	31.8	33.65	18.46
16	33.9	35.82	18.46
17	36.0	37.99	20.63
18	38.1	40.16	20.63
19	40.2	42.33	22.80
20	42.4	44.50	22.80
21	44.5	46.67	24.97
22	46.6	48.84	24.97
23	48.7	51.01	27.14
24	50.8	53.18	27.14
25	53.0	55.35	29.31
26	55.1	57.52	29.31
27	57.2	59.69	31.48
28	59.3	61.86	31.48
30	63.6	66.20	33.65
40	84.8	87.90	44.50
50	106.0	109.60	55.35
EX-10	6.8	-	-

<sup>1</sup> Based on Stormtech site calculator for SC-740 chambers

- 150mm stone above chambers
- 40% void ratio for surrounding stone
- 1 row; Width = 1.90m
- 2 rows; Width = 3.35m
- Includes end caps

4837 Albion Road - Hard Rock Ottawa (116111)  
 PCSWMM Storage Curves - Existing Conditions

STM ID	CB ID	Provided Storage	
		Underground	Surface
<b>EX-CB10</b>	<b>S01</b>	<b>6.8</b>	<b>44.4</b>
Depth (m)	Equivalent Area (m <sup>2</sup> )	Incremental Volume (m <sup>3</sup> )	Total Volume (m <sup>3</sup> )
0.00	0.00	0.0	0.0
0.40	34.00	6.8	6.8
0.41	0.00	0.2	7.0
1.10	0.00	0.0	7.0
1.26	555.00	44.4	51.4
1.27	0.00	2.8	54.1
2.10	0.00	0.0	54.1

EX-10x Infiltration Storage Chambers (6.8 m<sup>3</sup>)  
 0.16m Static Ponding Depth (44.4 m<sup>3</sup>)

STM ID	CB ID	Provided Storage	
		Underground	Surface
<b>EX-CB100</b>	<b>S02</b>	<b>6.8</b>	<b>0.0</b>
Depth (m)	Equivalent Area (m <sup>2</sup> )	Incremental Volume (m <sup>3</sup> )	Total Volume (m <sup>3</sup> )
0.00	0.00	0.0	0.0
0.40	34.00	6.8	6.8
0.41	0.00	0.2	7.0
0.95	0.00	0.0	7.0
1.18	0.00	0.0	7.0
1.19	0.00	0.0	7.0
1.95	0.00	0.0	7.0

EX-10x Infiltration Storage Chambers (6.8 m<sup>3</sup>)  
 0.23m Static Ponding Depth (0 m<sup>3</sup>)

STM ID	CB ID	Provided Storage	
		Underground	Surface
<b>EX-CB102</b>	<b>S03</b>	<b>6.8</b>	<b>63.4</b>
Depth (m)	Equivalent Area (m <sup>2</sup> )	Incremental Volume (m <sup>3</sup> )	Total Volume (m <sup>3</sup> )
0.00	0.00	0.0	0.0
0.40	34.00	6.8	6.8
0.41	0.00	0.2	7.0
0.94	0.00	0.0	7.0
1.20	487.69	63.4	70.4
1.21	0.00	2.4	72.8
1.94	0.00	0.0	72.8

EX-10x Infiltration Storage Chambers (6.8 m<sup>3</sup>)  
 0.26m Static Ponding Depth (63.4 m<sup>3</sup>)

4837 Albion Road - Hard Rock Ottawa (116111)  
 PCSWMM Storage Curves - Existing Conditions

STM ID	CB ID	Provided Storage	
		Underground	Surface
<b>EX-CB104</b>	<b>S04</b>	<b>6.8</b>	<b>263.4</b>
Depth (m)	Equivalent Area (m <sup>2</sup> )	Incremental Volume (m <sup>3</sup> )	Total Volume (m <sup>3</sup> )
0.00	0.00	0.0	0.0
0.40	34.00	6.8	6.8
0.41	0.00	0.2	7.0
1.27	0.00	0.0	7.0
1.66	1350.77	263.4	270.4
1.67	0.00	6.8	277.1
2.27	0.00	0.0	277.1

EX-10x Infiltration Storage Chambers (6.8 m<sup>3</sup>)  
 0.39m Static Ponding Depth (263.4 m<sup>3</sup>)

STM ID	CB ID	Provided Storage	
		Underground	Surface
<b>EX-CB106</b>	<b>S05</b>	<b>6.8</b>	<b>111.2</b>
Depth (m)	Equivalent Area (m <sup>2</sup> )	Incremental Volume (m <sup>3</sup> )	Total Volume (m <sup>3</sup> )
0.00	0.00	0.0	0.0
0.40	34.00	6.8	6.8
0.41	0.00	0.2	7.0
1.40	0.00	0.0	7.0
1.69	766.90	111.2	118.2
1.70	0.00	3.8	122.0
2.40	0.00	0.0	122.0

EX-10x Infiltration Storage Chambers (6.8 m<sup>3</sup>)  
 0.29m Static Ponding Depth (111.2 m<sup>3</sup>)

STM ID	CB ID	Provided Storage	
		Underground	Surface
<b>EX-CB110</b>	<b>S06</b>	<b>6.8</b>	<b>72.3</b>
Depth (m)	Equivalent Area (m <sup>2</sup> )	Incremental Volume (m <sup>3</sup> )	Total Volume (m <sup>3</sup> )
0.00	0.00	0.0	0.0
0.40	34.00	6.8	6.8
0.41	0.00	0.2	7.0
1.24	0.00	0.0	7.0
1.50	556.15	72.3	79.3
1.51	0.00	2.8	82.1
2.24	0.00	0.0	82.1

EX-10x Infiltration Storage Chambers (6.8 m<sup>3</sup>)  
 0.26m Static Ponding Depth (72.3 m<sup>3</sup>)

4837 Albion Road - Hard Rock Ottawa (116111)  
 PCSWMM Storage Curves - Existing Conditions

STM ID	CB ID	Provided Storage	
		Underground	Surface
EX-CB113	S07	6.8	66.8
Depth (m)	Equivalent Area (m <sup>2</sup> )	Incremental Volume (m <sup>3</sup> )	Total Volume (m <sup>3</sup> )
0.00	0.00	0.0	0.0
0.40	34.00	6.8	6.8
0.41	0.00	0.2	7.0
1.26	0.00	0.0	7.0
1.50	556.67	66.8	73.8
1.51	0.00	2.8	76.6
2.26	0.00	0.0	76.6

EX-10x Infiltration Storage Chambers (6.8 m<sup>3</sup>)  
 0.24m Static Ponding Depth (66.8 m<sup>3</sup>)

STM ID	CB ID	Provided Storage	
		Underground	Surface
EX-CB116	S08	6.8	37.2
Depth (m)	Equivalent Area (m <sup>2</sup> )	Incremental Volume (m <sup>3</sup> )	Total Volume (m <sup>3</sup> )
0.00	0.00	0.0	0.0
0.40	34.00	6.8	6.8
0.41	0.00	0.2	7.0
0.43	0.00	0.0	7.0
0.62	391.58	37.2	44.2
0.63	0.00	2.0	46.1
1.43	0.00	0.0	46.1

EX-10x Infiltration Storage Chambers (6.8 m<sup>3</sup>)  
 0.19m Static Ponding Depth (37.2 m<sup>3</sup>)

STM ID	CB ID	Provided Storage	
		Underground	Surface
EX-CB117	S09	6.8	31.3
Depth (m)	Equivalent Area (m <sup>2</sup> )	Incremental Volume (m <sup>3</sup> )	Total Volume (m <sup>3</sup> )
0.00	0.00	0.0	0.0
0.40	34.00	6.8	6.8
0.41	0.00	0.2	7.0
1.36	0.00	0.0	7.0
1.52	391.25	31.3	38.3
1.53	0.00	2.0	40.2
2.36	0.00	0.0	40.2

EX-10x Infiltration Storage Chambers (6.8 m<sup>3</sup>)  
 0.16m Static Ponding Depth (31.3 m<sup>3</sup>)



4837 Albion Road - Hard Rock Ottawa (116111)  
 PCSWMM Storage Curves - Existing Conditions

STM ID	CB ID	Provided Storage	
		Underground	Surface
<b>EX-CB121</b>	<b>S10</b>	<b>6.8</b>	<b>39.2</b>
Depth (m)	Equivalent Area (m <sup>2</sup> )	Incremental Volume (m <sup>3</sup> )	Total Volume (m <sup>3</sup> )
0.00	0.00	0.0	0.0
0.40	34.00	6.8	6.8
0.41	0.00	0.2	7.0
1.26	0.00	0.0	7.0
1.46	392.00	39.2	46.2
1.47	0.00	2.0	48.1
2.26	0.00	0.0	48.1

EX-10x Infiltration Storage Chambers (6.8 m<sup>3</sup>)  
 0.2m Static Ponding Depth (39.2 m<sup>3</sup>)

STM ID	CB ID	Provided Storage	
		Underground	Surface
<b>EX-CB123/124</b>	<b>S11</b>	<b>13.6</b>	<b>48.9</b>
Depth (m)	Equivalent Area (m <sup>2</sup> )	Incremental Volume (m <sup>3</sup> )	Total Volume (m <sup>3</sup> )
0.00	0.00	0.0	0.0
0.40	68.00	13.6	13.6
0.41	0.00	0.3	13.9
1.56	0.00	0.0	13.9
1.81	391.20	48.9	62.8
1.82	0.00	2.0	64.8
2.56	0.00	0.0	64.8

EX-10 (x2)x Infiltration Storage Chambers (13.6 m<sup>3</sup>)  
 0.25m Static Ponding Depth (48.9 m<sup>3</sup>)

STM ID	CB ID	Provided Storage	
		Underground	Surface
<b>EX-CB128</b>	<b>S12</b>	<b>6.8</b>	<b>37.3</b>
Depth (m)	Equivalent Area (m <sup>2</sup> )	Incremental Volume (m <sup>3</sup> )	Total Volume (m <sup>3</sup> )
0.00	0.00	0.0	0.0
0.40	34.00	6.8	6.8
0.41	0.00	0.2	7.0
1.20	0.00	0.0	7.0
1.45	298.40	37.3	44.3
1.46	0.00	1.5	45.8
2.20	0.00	0.0	45.8

EX-10x Infiltration Storage Chambers (6.8 m<sup>3</sup>)  
 0.25m Static Ponding Depth (37.3 m<sup>3</sup>)

4837 Albion Road - Hard Rock Ottawa (116111)  
 PCSWMM Storage Curves - Existing Conditions

STM ID	CB ID	Provided Storage	
		Underground	Surface
<b>EX-CB132</b>	<b>S38</b>	<b>0.0</b>	<b>0.0</b>
Depth (m)	Equivalent Area (m <sup>2</sup> )	Incremental Volume (m <sup>3</sup> )	Total Volume (m <sup>3</sup> )
0.00	0.00	0.0	0.0
0.40	0.00	0.0	0.0
0.41	0.00	0.0	0.0
2.43	0.00	0.0	0.0
3.73	0.00	0.0	0.0
3.74	0.00	0.0	0.0
3.43	0.00	0.0	0.0

-x Infiltration Storage Chambers (- m3)  
 1.3m Static Ponding Depth (0 m3)

STM ID	CB ID	Provided Storage	
		Underground	Surface
<b>EX-CB134</b>	<b>S13</b>	<b>0.0</b>	<b>7.9</b>
Depth (m)	Equivalent Area (m <sup>2</sup> )	Incremental Volume (m <sup>3</sup> )	Total Volume (m <sup>3</sup> )
0.00	0.00	0.0	0.0
0.40	0.00	0.0	0.0
0.41	0.00	0.0	0.0
1.76	0.00	0.0	0.0
1.91	105.33	7.9	7.9
1.92	0.00	0.5	8.4
2.76	0.00	0.0	8.4

-x Infiltration Storage Chambers (- m3)  
 0.15m Static Ponding Depth (7.9 m3)

STM ID	CB ID	Provided Storage	
		Underground	Surface
<b>EX-CB137</b>	<b>S14</b>	<b>6.8</b>	<b>9.5</b>
Depth (m)	Equivalent Area (m <sup>2</sup> )	Incremental Volume (m <sup>3</sup> )	Total Volume (m <sup>3</sup> )
0.00	0.00	0.0	0.0
0.40	34.00	6.8	6.8
0.41	0.00	0.2	7.0
1.41	0.00	0.0	7.0
1.60	100.00	9.5	16.5
1.61	0.00	0.5	17.0
2.41	0.00	0.0	17.0

EX-10x Infiltration Storage Chambers (6.8 m3)  
 0.19m Static Ponding Depth (9.5 m3)

4837 Albion Road - Hard Rock Ottawa (116111)  
 PCSWMM Storage Curves - Existing Conditions

STM ID	CB ID	Provided Storage	
		Underground	Surface
EX-CB28	S15	6.8	230.3
Depth (m)	Equivalent Area (m <sup>2</sup> )	Incremental Volume (m <sup>3</sup> )	Total Volume (m <sup>3</sup> )
0.00	0.00	0.0	0.0
0.40	34.00	6.8	6.8
0.41	0.00	0.2	7.0
1.22	0.00	0.0	7.0
1.57	1316.00	230.3	237.3
1.58	0.00	6.6	243.9
2.22	0.00	0.0	243.9

EX-10x Infiltration Storage Chambers (6.8 m<sup>3</sup>)  
 0.35m Static Ponding Depth (230.3 m<sup>3</sup>)

STM ID	CB ID	Provided Storage	
		Underground	Surface
EX-CB30	S16	6.8	168.9
Depth (m)	Equivalent Area (m <sup>2</sup> )	Incremental Volume (m <sup>3</sup> )	Total Volume (m <sup>3</sup> )
0.00	0.00	0.0	0.0
0.40	34.00	6.8	6.8
0.41	0.00	0.2	7.0
1.19	0.00	0.0	7.0
1.50	1089.68	168.9	175.9
1.51	0.00	5.4	181.3
2.19	0.00	0.0	181.3

EX-10x Infiltration Storage Chambers (6.8 m<sup>3</sup>)  
 0.31m Static Ponding Depth (168.9 m<sup>3</sup>)

STM ID	CB ID	Provided Storage	
		Underground	Surface
EX-CB38	S17	6.8	60.2
Depth (m)	Equivalent Area (m <sup>2</sup> )	Incremental Volume (m <sup>3</sup> )	Total Volume (m <sup>3</sup> )
0.00	0.00	0.0	0.0
0.40	34.00	6.8	6.8
0.41	0.00	0.2	7.0
0.77	0.00	0.0	7.0
1.04	445.93	60.2	67.2
1.05	0.00	2.2	69.4
1.77	0.00	0.0	69.4

EX-10x Infiltration Storage Chambers (6.8 m<sup>3</sup>)  
 0.27m Static Ponding Depth (60.2 m<sup>3</sup>)

4837 Albion Road - Hard Rock Ottawa (116111)  
PCSWMM Storage Curves - Existing Conditions

STM ID	CB ID	Provided Storage	
		Underground	Surface
EX-CB40	S18	6.8	58.0
Depth (m)	Equivalent Area (m <sup>2</sup> )	Incremental Volume (m <sup>3</sup> )	Total Volume (m <sup>3</sup> )
0.00	0.00	0.0	0.0
0.40	34.00	6.8	6.8
0.41	0.00	0.2	7.0
0.72	0.00	0.0	7.0
0.98	446.15	58.0	65.0
0.99	0.00	2.2	67.2
1.72	0.00	0.0	67.2

EX-10x Infiltration Storage Chambers (6.8 m<sup>3</sup>)  
0.26m Static Ponding Depth (58 m<sup>3</sup>)

STM ID	CB ID	Provided Storage	
		Underground	Surface
EX-CB50	S19	6.8	164.2
Depth (m)	Equivalent Area (m <sup>2</sup> )	Incremental Volume (m <sup>3</sup> )	Total Volume (m <sup>3</sup> )
0.00	0.00	0.0	0.0
0.40	34.00	6.8	6.8
0.41	0.00	0.2	7.0
1.39	0.00	0.0	7.0
1.68	1132.41	164.2	171.2
1.69	0.00	5.7	176.8
2.39	0.00	0.0	176.8

EX-10x Infiltration Storage Chambers (6.8 m<sup>3</sup>)  
0.29m Static Ponding Depth (164.2 m<sup>3</sup>)

STM ID	CB ID	Provided Storage	
		Underground	Surface
EX-CB52	S20	6.8	149.2
Depth (m)	Equivalent Area (m <sup>2</sup> )	Incremental Volume (m <sup>3</sup> )	Total Volume (m <sup>3</sup> )
0.00	0.00	0.0	0.0
0.40	34.00	6.8	6.8
0.41	0.00	0.2	7.0
1.27	0.00	0.0	7.0
1.54	1105.19	149.2	156.2
1.55	0.00	5.5	161.7
2.27	0.00	0.0	161.7

EX-10x Infiltration Storage Chambers (6.8 m<sup>3</sup>)  
0.27m Static Ponding Depth (149.2 m<sup>3</sup>)

4837 Albion Road - Hard Rock Ottawa (116111)  
 PCSWMM Storage Curves - Existing Conditions

STM ID	CB ID	Provided Storage	
		Underground	Surface
EX-CB54	S21	6.8	0.0
Depth (m)	Equivalent Area (m <sup>2</sup> )	Incremental Volume (m <sup>3</sup> )	Total Volume (m <sup>3</sup> )
0.00	0.00	0.0	0.0
0.40	34.00	6.8	6.8
0.41	0.00	0.2	7.0
1.31	0.00	0.0	7.0
1.31	0.00	0.0	7.0
1.32	0.00	0.0	7.0
2.31	0.00	0.0	7.0

EX-10x Infiltration Storage Chambers (6.8 m<sup>3</sup>)  
 0m Static Ponding Depth (0 m<sup>3</sup>)

STM ID	CB ID	Provided Storage	
		Underground	Surface
EX-CB58	S22	6.8	118.8
Depth (m)	Equivalent Area (m <sup>2</sup> )	Incremental Volume (m <sup>3</sup> )	Total Volume (m <sup>3</sup> )
0.00	0.00	0.0	0.0
0.40	34.00	6.8	6.8
0.41	0.00	0.2	7.0
1.29	0.00	0.0	7.0
1.56	880.00	118.8	125.8
1.57	0.00	4.4	130.2
2.29	0.00	0.0	130.2

EX-10x Infiltration Storage Chambers (6.8 m<sup>3</sup>)  
 0.27m Static Ponding Depth (118.8 m<sup>3</sup>)

STM ID	CB ID	Provided Storage	
		Underground	Surface
EX-CB60	S23	0.0	36.6
Depth (m)	Equivalent Area (m <sup>2</sup> )	Incremental Volume (m <sup>3</sup> )	Total Volume (m <sup>3</sup> )
0.00	0.00	0.0	0.0
0.40	0.00	0.0	0.0
0.41	0.00	0.0	0.0
1.58	0.00	0.0	0.0
1.81	318.26	36.6	36.6
1.82	0.00	1.6	38.2
2.58	0.00	0.0	38.2

-x Stormtech STC-740 Storage Chambers (- m<sup>3</sup>)  
 0.23m Static Ponding Depth (36.6 m<sup>3</sup>)

4837 Albion Road - Hard Rock Ottawa (116111)  
 PCSWMM Storage Curves - Existing Conditions

STM ID	CB ID	Provided Storage	
		Underground	Surface
EX-CB62	S24	0.0	31.8
Depth (m)	Equivalent Area (m <sup>2</sup> )	Incremental Volume (m <sup>3</sup> )	Total Volume (m <sup>3</sup> )
0.00	0.00	0.0	0.0
0.40	0.00	0.0	0.0
0.41	0.00	0.0	0.0
1.12	0.00	0.0	0.0
1.32	318.00	31.8	31.8
1.33	0.00	1.6	33.4
2.12	0.00	0.0	33.4

-x Stormtech STC-740 Storage Chambers (- m3)  
 0.2m Static Ponding Depth (31.8 m3)

STM ID	CB ID	Provided Storage	
		Underground	Surface
EX-CB64	S25	6.8	86.5
Depth (m)	Equivalent Area (m <sup>2</sup> )	Incremental Volume (m <sup>3</sup> )	Total Volume (m <sup>3</sup> )
0.00	0.00	0.0	0.0
0.40	34.00	6.8	6.8
0.41	0.00	0.2	7.0
1.63	0.00	0.0	7.0
1.88	692.00	86.5	93.5
1.89	0.00	3.5	96.9
2.63	0.00	0.0	96.9

EX-10x Stormtech STC-740 Storage Chambers (6.8 m3)  
 0.25m Static Ponding Depth (86.5 m3)

STM ID	CB ID	Provided Storage	
		Underground	Surface
EX-CB66	S26	6.8	225.8
Depth (m)	Equivalent Area (m <sup>2</sup> )	Incremental Volume (m <sup>3</sup> )	Total Volume (m <sup>3</sup> )
0.00	0.00	0.0	0.0
0.40	34.00	6.8	6.8
0.41	0.00	0.2	7.0
1.29	0.00	0.0	7.0
1.67	1188.42	225.8	232.8
1.68	0.00	5.9	238.7
2.29	0.00	0.0	238.7

EX-10x Stormtech STC-740 Storage Chambers (6.8 m3)  
 0.38m Static Ponding Depth (225.8 m3)

4837 Albion Road - Hard Rock Ottawa (116111)  
 PCSWMM Storage Curves - Existing Conditions

STM ID	CB ID	Provided Storage	
		Underground	Surface
EX-CB68	S27	6.8	102.1
Depth (m)	Equivalent Area (m <sup>2</sup> )	Incremental Volume (m <sup>3</sup> )	Total Volume (m <sup>3</sup> )
0.00	0.00	0.0	0.0
0.40	34.00	6.8	6.8
0.41	0.00	0.2	7.0
1.15	0.00	0.0	7.0
1.43	729.29	102.1	109.1
1.44	0.00	3.6	112.7
2.15	0.00	0.0	112.7

EX-10x Stormtech STC-740 Storage Chambers (6.8 m3)  
 0.28m Static Ponding Depth (102.1 m3)

STM ID	CB ID	Provided Storage	
		Underground	Surface
EX-CB82	S28	6.8	78.7
Depth (m)	Equivalent Area (m <sup>2</sup> )	Incremental Volume (m <sup>3</sup> )	Total Volume (m <sup>3</sup> )
0.00	0.00	0.0	0.0
0.40	34.00	6.8	6.8
0.41	0.00	0.2	7.0
1.22	0.00	0.0	7.0
1.43	749.52	78.7	85.7
1.44	0.00	3.7	89.4
2.22	0.00	0.0	89.4

EX-10x Stormtech STC-740 Storage Chambers (6.8 m3)  
 0.21m Static Ponding Depth (78.7 m3)

STM ID	CB ID	Provided Storage	
		Underground	Surface
EX-CB84	S29	6.8	156.5
Depth (m)	Equivalent Area (m <sup>2</sup> )	Incremental Volume (m <sup>3</sup> )	Total Volume (m <sup>3</sup> )
0.00	0.00	0.0	0.0
0.40	34.00	6.8	6.8
0.41	0.00	0.2	7.0
1.53	0.00	0.0	7.0
1.89	869.44	156.5	163.5
1.90	0.00	4.3	167.8
2.53	0.00	0.0	167.8

EX-10x Stormtech STC-740 Storage Chambers (6.8 m3)  
 0.36m Static Ponding Depth (156.5 m3)

4837 Albion Road - Hard Rock Ottawa (116111)  
 PCSWMM Storage Curves - Existing Conditions

STM ID	CB ID	Provided Storage	
		Underground	Surface
EX-CB87	S30	6.8	124.3
Depth (m)	Equivalent Area (m <sup>2</sup> )	Incremental Volume (m <sup>3</sup> )	Total Volume (m <sup>3</sup> )
0.00	0.00	0.0	0.0
0.40	34.00	6.8	6.8
0.41	0.00	0.2	7.0
1.18	0.00	0.0	7.0
1.45	920.74	124.3	131.3
1.46	0.00	4.6	135.9
2.18	0.00	0.0	135.9

EX-10x Stormtech STC-740 Storage Chambers (6.8 m3)  
 0.27m Static Ponding Depth (124.3 m3)

STM ID	CB ID	Provided Storage	
		Underground	Surface
EX-CB90	S31	6.8	91.5
Depth (m)	Equivalent Area (m <sup>2</sup> )	Incremental Volume (m <sup>3</sup> )	Total Volume (m <sup>3</sup> )
0.00	0.00	0.0	0.0
0.40	34.00	6.8	6.8
0.41	0.00	0.2	7.0
1.28	0.00	0.0	7.0
1.44	1143.75	91.5	98.5
1.45	0.00	5.7	104.2
2.28	0.00	0.0	104.2

EX-10x Stormtech STC-740 Storage Chambers (6.8 m3)  
 0.16m Static Ponding Depth (91.5 m3)

STM ID	CB ID	Provided Storage	
		Underground	Surface
EX-CB92	S32	6.8	110.7
Depth (m)	Equivalent Area (m <sup>2</sup> )	Incremental Volume (m <sup>3</sup> )	Total Volume (m <sup>3</sup> )
0.00	0.00	0.0	0.0
0.40	34.00	6.8	6.8
0.41	0.00	0.2	7.0
1.18	0.00	0.0	7.0
1.46	790.71	110.7	117.7
1.47	0.00	4.0	121.6
2.18	0.00	0.0	121.6

EX-10x Stormtech STC-740 Storage Chambers (6.8 m3)  
 0.28m Static Ponding Depth (110.7 m3)



4837 Albion Road - Hard Rock Ottawa (116111)  
PCSWMM Storage Curves - Existing Conditions

STM ID	CB ID	Provided Storage	
		Underground	Surface
EX-CB95	S33	6.8	43.3
Depth (m)	Equivalent Area (m <sup>2</sup> )	Incremental Volume (m <sup>3</sup> )	Total Volume (m <sup>3</sup> )
0.00	0.00	0.0	0.0
0.40	34.00	6.8	6.8
0.41	0.00	0.2	7.0
1.22	0.00	0.0	7.0
1.51	298.62	43.3	50.3
1.52	0.00	1.5	51.8
2.22	0.00	0.0	51.8

EX-10x Stormtech STC-740 Storage Chambers (6.8 m3)  
0.29m Static Ponding Depth (43.3 m3)

STM ID	CB ID	Provided Storage	
		Underground	Surface
EX-CB96	S34	6.8	211.8
Depth (m)	Equivalent Area (m <sup>2</sup> )	Incremental Volume (m <sup>3</sup> )	Total Volume (m <sup>3</sup> )
0.00	0.00	0.0	0.0
0.40	34.00	6.8	6.8
0.41	0.00	0.2	7.0
1.40	0.00	0.0	7.0
1.73	1283.64	211.8	218.8
1.74	0.00	6.4	225.2
2.40	0.00	0.0	225.2

EX-10x Stormtech STC-740 Storage Chambers (6.8 m3)  
0.33m Static Ponding Depth (211.8 m3)

STM ID	CB ID	Provided Storage	
		Underground	Surface
EX-CBMH117	S35	6.8	39.3
Depth (m)	Equivalent Area (m <sup>2</sup> )	Incremental Volume (m <sup>3</sup> )	Total Volume (m <sup>3</sup> )
0.00	0.00	0.0	0.0
0.40	34.00	6.8	6.8
0.41	0.00	0.2	7.0
1.48	0.00	0.0	7.0
1.59	714.55	39.3	46.3
1.60	0.00	3.6	49.8
2.48	0.00	0.0	49.8

EX-10x Stormtech STC-740 Storage Chambers (6.8 m3)  
0.11m Static Ponding Depth (39.3 m3)

STM ID	CB ID	Provided Storage	
		Underground	Surface
EX-MH102Aa	S36	6.8	0.0
Depth (m)	Equivalent Area (m <sup>2</sup> )	Incremental Volume (m <sup>3</sup> )	Total Volume (m <sup>3</sup> )
0.00	0.00	0.0	0.0
0.40	34.00	6.8	6.8
0.41	0.00	0.2	7.0
1.74	0.00	0.0	7.0
1.89	0.00	0.0	7.0
1.90	0.00	0.0	7.0
2.74	0.00	0.0	7.0

EX-10x Stormtech STC-740 Storage Chambers (6.8 m3)  
0.15m Static Ponding Depth (0 m3)

4837 Albion Road - Hard Rock Ottawa (116111)  
 PCSWMM Model Results - Existing Conditions (ICDs)

CB / CBMH ID	PCSWMM Orifice Dia. (mm)	Release Rate (L/s) <sup>1</sup>				Head (m) <sup>1</sup>			
		2-yr	5-yr	100-yr	100-yr (+20%)	2-yr	5-yr	100-yr	100-yr (+20%)
EX-CB110	70	11.3	11.5	13.2	13.3	1.40	1.46	1.92	1.97
EX-CB113	70	11.3	11.5	13.4	13.5	1.40	1.46	1.96	2.00
EX-CB117	70	12.5	12.7	14.1	14.2	1.47	1.52	1.87	1.91
EX-CB121	70	12.2	12.7	13.9	14.1	1.42	1.53	1.82	1.87
EX-CB123/124	80	17.8	18.6	19.5	19.7	1.76	1.91	2.10	2.14
EX-CB132	80	21.2	21.3	21.9	22.1	2.78	2.81	2.95	2.99
EX-CB134	83	19.3	19.7	20.0	20.1	1.78	1.85	1.92	1.92
EX-CB137	80	17.1	17.2	18.4	18.4	1.62	1.65	1.88	1.87
EX-CB14	140	109.3	110.9	115.4	117.8	1.82	1.87	2.05	2.15
EX-CB38	70	4.1	4.8	6.1	9.4	0.19	0.25	0.38	0.85
EX-CB40	70	4.1	4.8	6.1	8.8	0.19	0.25	0.38	0.76
EX-CB72	65	7.1	9.5	13.1	13.1	0.65	1.15	2.15	2.16
EX-CB82	83	18.1	18.4	18.9	19.0	1.57	1.62	1.71	1.73
EX-CB84	80	18.1	19.0	19.9	20.0	1.82	1.99	2.19	2.21
EX-CBMH117	83	18.0	18.3	18.6	18.7	1.57	1.62	1.68	1.69
EX-MH106a	83	21.3	21.5	22.0	22.2	2.16	2.21	2.30	2.35
EX-MH110	83	18.9	19.1	19.6	19.7	1.74	1.78	1.87	1.89
EX-STM43	140	35.6	41.9	49.7	49.8	0.80	1.09	1.50	1.51

<sup>1</sup> 3-hour Chicago Storm.

4837 Albion Road - Hard Rock Ottawa (116111)  
 PCSWMM Model Results - Existing Conditions (Ponding)



CB / CBMH ID	Invert Elev. (m)	Rim Elev. (m)	Spill Elev. (m)	Ponding Depth (m)	HGL Elev. (m) <sup>1</sup>				Ponding Depth (m)				Spill Depth (m)			
					2-yr	5-yr	100-yr	100-yr (+20%)	2-yr	5-yr	100-yr	100-yr (+20%)	2-yr	5-yr	100-yr	100-yr (+20%)
EX-CB10	111.51	113.24	113.50	0.26	112.81	112.84	112.90	112.93	0.00	0.00	0.00	0.00	0.00	0.00	0.00	0.00
EX-CB100	112.77	113.26	113.50	0.24	113.83	113.88	113.98	114.01	0.57	0.62	0.72	0.75	0.33	0.38	0.48	0.51
EX-CB102	112.69	113.42	113.61	0.19	113.83	113.88	113.98	114.01	0.41	0.46	0.56	0.59	0.22	0.27	0.37	0.40
EX-CB104	112.40	113.45	113.61	0.16	113.83	113.88	113.97	114.00	0.38	0.43	0.52	0.55	0.22	0.27	0.36	0.39
EX-CB106	112.31	113.41	113.61	0.20	113.83	113.87	113.96	113.99	0.42	0.46	0.55	0.58	0.22	0.26	0.35	0.38
EX-CB110	112.00	113.36	113.61	0.25	113.40	113.46	113.92	113.97	0.04	0.10	0.56	0.61	0.00	0.00	0.31	0.36
EX-CB113	112.00	113.71	113.96	0.25	113.40	113.46	113.96	114.00	0.00	0.00	0.25	0.29	0.00	0.00	0.00	0.04
EX-CB116	112.99	111.31	112.61	1.30	113.56	113.62	113.95	114.00	2.25	2.31	2.64	2.69	0.95	1.01	1.34	1.39
EX-CB117	112.09	113.36	113.51	0.15	113.56	113.61	113.96	114.00	0.20	0.25	0.60	0.64	0.05	0.10	0.45	0.49
EX-CB121	112.15	113.41	113.60	0.19	113.57	113.68	113.97	114.02	0.16	0.27	0.56	0.61	0.00	0.08	0.37	0.42
EX-CB123/124	111.80	113.65	114.00	0.35	113.56	113.71	113.90	113.94	0.00	0.06	0.25	0.29	0.00	0.00	0.00	0.00
EX-CB128	112.51	113.69	114.00	0.31	113.78	113.82	113.92	113.95	0.09	0.13	0.23	0.26	0.00	0.00	0.00	0.00
EX-CB132	108.88	113.63	113.90	0.27	111.66	111.69	111.83	111.87	0.00	0.00	0.00	0.00	0.00	0.00	0.00	0.00
EX-CB134	111.60	113.64	113.90	0.26	113.38	113.45	113.52	113.52	0.00	0.00	0.00	0.00	0.00	0.00	0.00	0.00
EX-CB137	112.00	113.71	114.00	0.29	113.62	113.65	113.88	113.87	0.00	0.00	0.17	0.16	0.00	0.00	0.00	0.00
EX-CB28	112.43	113.71	113.98	0.27	113.78	113.83	113.92	113.96	0.07	0.12	0.21	0.25	0.00	0.00	0.00	0.00
EX-CB30	112.50	113.83	113.83	0.00	113.79	113.84	113.94	113.99	0.00	0.01	0.11	0.16	0.00	0.01	0.11	0.16
EX-CB38	112.86	113.73	114.00	0.27	113.05	113.11	113.24	113.71	0.00	0.00	0.00	0.00	0.00	0.00	0.00	0.00
EX-CB40	112.92	113.73	113.96	0.23	113.11	113.17	113.30	113.68	0.00	0.00	0.00	0.00	0.00	0.00	0.00	0.00
EX-CB50	112.32	113.76	113.96	0.20	113.84	113.88	113.97	114.00	0.08	0.12	0.21	0.24	0.00	0.00	0.01	0.04
EX-CB52	112.44	113.73	113.98	0.25	113.84	113.88	113.97	114.01	0.11	0.15	0.24	0.28	0.00	0.00	0.00	0.03
EX-CB54	112.52	113.66	114.04	0.38	113.84	113.88	113.99	114.01	0.18	0.22	0.33	0.35	0.00	0.00	0.00	0.00
EX-CB58	112.44	113.72	114.00	0.28	113.84	113.88	114.00	114.05	0.12	0.16	0.28	0.33	0.00	0.00	0.00	0.05

4837 Albion Road - Hard Rock Ottawa (116111)  
 PCSWMM Model Results - Existing Conditions (Ponding)



CB / CBMH ID	Invert Elev. (m)	Rim Elev. (m)	Spill Elev. (m)	Ponding Depth (m)	HGL Elev. (m) <sup>1</sup>				Ponding Depth (m)				Spill Depth (m)			
					2-yr	5-yr	100-yr	100-yr (+20%)	2-yr	5-yr	100-yr	100-yr (+20%)	2-yr	5-yr	100-yr	100-yr (+20%)
EX-CB60	112.15	113.84	114.05	0.21	113.83	113.87	113.96	113.97	0.00	0.03	0.12	0.13	0.00	0.00	0.00	0.00
EX-CB62	112.64	113.65	114.01	0.36	113.83	113.87	113.96	113.97	0.18	0.22	0.31	0.32	0.00	0.00	0.00	0.00
EX-CB64	112.10	113.68	113.95	0.27	113.82	113.86	113.95	113.97	0.14	0.18	0.27	0.29	0.00	0.00	0.00	0.02
EX-CB66	112.37	113.79	113.95	0.16	113.82	113.86	113.95	113.98	0.03	0.07	0.16	0.19	0.00	0.00	0.00	0.03
EX-CB68	112.57	113.67	113.95	0.28	113.82	113.86	113.95	113.98	0.15	0.19	0.28	0.31	0.00	0.00	0.00	0.03
EX-CB82	112.62	113.67	113.96	0.29	114.19	114.24	114.33	114.35	0.52	0.57	0.66	0.68	0.23	0.28	0.37	0.39
EX-CB84	112.12	113.62	113.95	0.33	113.94	114.11	114.31	114.33	0.32	0.49	0.69	0.71	0.00	0.16	0.36	0.38
EX-CB87	112.50	112.74	112.85	0.11	113.77	113.82	113.91	113.94	1.03	1.08	1.17	1.20	0.92	0.97	1.06	1.09
EX-CB90	112.51	114.16	114.31	0.15	113.81	113.84	113.91	113.94	0.00	0.00	0.00	0.00	0.00	0.00	0.00	0.00
EX-CB92	112.49	113.45	113.75	0.30	113.78	113.83	113.92	113.95	0.33	0.38	0.47	0.50	0.03	0.08	0.17	0.20
EX-CB95	112.45	113.60	113.85	0.25	113.78	113.82	113.92	113.95	0.18	0.22	0.32	0.35	0.00	0.00	0.07	0.10
EX-CB96	112.22	113.60	113.87	0.27	113.78	113.82	113.92	113.95	0.18	0.22	0.32	0.35	0.00	0.00	0.05	0.08
EX-CBMH117	111.26	113.65	113.72	0.07	112.83	112.88	112.94	112.95	0.00	0.00	0.00	0.00	0.00	0.00	0.00	0.00
EX-MH102A	112.42	113.55	113.65	0.10	112.87	112.89	112.96	112.99	0.00	0.00	0.00	0.00	0.00	0.00	0.00	0.00

<sup>1</sup> 3-hour Chicago Storm.

4837 Albion Road - Hard Rock Ottawa (116111)

Existing Conditions - Summary of Hydraulic Grade Line (HGL) Elevations



MH ID	Obvert Elevation (m)	T/G Elevation (m)	HGL Elevation <sup>1</sup> (m)	Surcharge (m)	Clearance from T/G (m)	HGL in Stress Test <sup>1</sup> (m)
EX-MH101	105.32	106.91	104.89	0.00	2.02	104.89
EX-MH101a	107.93	112.19	107.51	0.00	4.68	107.52
EX-MH101b	106.08	110.41	105.62	0.00	4.79	105.62
EX-MH102	110.13	114.07	109.70	0.00	4.37	109.70
EX-MH102A	112.72	114.16	112.96	0.24	1.20	112.99
EX-MH103	111.01	113.00	110.78	0.00	2.22	110.78
EX-MH104	111.25	113.90	110.96	0.00	2.94	110.96
EX-MH105	111.28	114.02	111.41	0.13	2.61	111.41
EX-MH106	112.60	113.99	113.91	1.31	0.08	113.97
EX-MH107	114.95	114.95	113.92	0.00	1.03	113.99
EX-MH108	111.70	113.67	111.92	0.23	1.75	111.93
EX-MH109	111.58	113.56	111.43	0.00	2.13	111.44
EX-MH110	112.15	114.91	113.95	1.80	0.96	113.97
EX-MH111	112.37	114.18	113.96	1.59	0.22	113.98
EX-MH112	114.94	114.94	114.06	0.00	0.88	114.07
EX-MH113	112.16	113.59	112.39	0.23	1.20	112.41
EX-MH114	112.76	113.70	112.60	0.00	1.10	112.63
EX-MH115	105.35	106.87	105.27	0.00	1.60	105.27
EX-MH116	107.87	107.87	105.72	0.00	2.15	105.72

<sup>1</sup> 3-hour Chicago Storm.

4837 Albion Road - Hard Rock Ottawa (116111)  
 PCSWMM Model Results - Ex. Conditions (100-year, 3-hour Chicago Storm)

EPA STORM WATER MANAGEMENT MODEL - VERSION 5.1 (Build 5.1.013)

WARNING 10: crest elevation raised to downstream invert for regulator Link X-CB-112\_(X-CB)  
 WARNING 10: crest elevation raised to downstream invert for regulator Link X-CB-115\_(X-CB)  
 WARNING 10: crest elevation raised to downstream invert for regulator Link X-CB-131\_(X-CB)

\*\*\*\*\*  
 Element Count  
 \*\*\*\*\*

Number of rain gages ..... 1  
 Number of subcatchments ... 40  
 Number of nodes ..... 155  
 Number of links ..... 198  
 Number of pollutants ..... 0  
 Number of land uses ..... 0

\*\*\*\*\*  
 Rainrage Summary  
 \*\*\*\*\*

Name	Data Source	Data Type	Recording Interval
Design_Storms	C3hr-100yr	INTENSITY	10 min.

\*\*\*\*\*  
 Subcatchment Summary  
 \*\*\*\*\*

Name	Area	Width	%Imperv	%Slope	Rain Gage	Outlet
BLDG	0.86	66.46	100.00	1.5000	Design_Storms	EX-BLDG01
S01	0.45	161.96	100.00	1.5000	Design_Storms	EX-CB10
S02	0.06	120.00	100.00	1.5000	Design_Storms	EX-CB100
S03	0.18	180.00	100.00	1.5000	Design_Storms	EX-CB102
S04	0.22	200.00	100.00	1.5000	Design_Storms	EX-CB104
S05	0.17	188.89	100.00	1.5000	Design_Storms	EX-CB106
S06	0.21	350.00	100.00	1.5000	Design_Storms	EX-CB110
S07	0.30	282.27	100.00	1.5000	Design_Storms	EX-CB113
S08	0.09	90.00	100.00	1.5000	Design_Storms	EX-CB116
S09	0.04	80.00	100.00	1.5000	Design_Storms	EX-CB117
S1	0.04	4.00	100.00	1.5000	Design_Storms	EX-CB72
S10	0.08	88.89	100.00	1.5000	Design_Storms	EX-CB121
S11	0.70	145.83	100.00	1.5000	Design_Storms	EX-CB123/124

S12	0.10	200.00	100.00	1.5000	Design_Storms	EX-CB128
S13	0.10	40.00	100.00	1.5000	Design_Storms	EX-CB134
S14	0.09	52.94	100.00	1.5000	Design_Storms	EX-CB137
S15	0.23	115.00	100.00	1.5000	Design_Storms	EX-CB28
S16	0.38	152.00	60.00	1.5000	Design_Storms	EX-CB30
S17	0.03	60.00	100.00	1.5000	Design_Storms	EX-CB38
S18	0.03	60.00	100.00	1.5000	Design_Storms	EX-CB40
S19	0.25	192.31	100.00	1.5000	Design_Storms	EX-CB50
S20	0.20	181.82	100.00	1.5000	Design_Storms	EX-CB52
S21	0.08	160.00	100.00	1.5000	Design_Storms	EX-CB54
S22	0.19	190.00	100.00	1.5000	Design_Storms	EX-CB58
S23	0.07	140.00	100.00	1.5000	Design_Storms	EX-CB60
S24	0.11	220.00	100.00	1.5000	Design_Storms	EX-CB62
S25	0.11	220.00	100.00	1.5000	Design_Storms	EX-CB64
S26	0.19	190.00	100.00	1.5000	Design_Storms	EX-CB66
S27	0.14	200.00	100.00	1.5000	Design_Storms	EX-CB68
S28	0.27	100.00	100.00	1.5000	Design_Storms	EX-CB82
S29	0.23	95.83	100.00	1.5000	Design_Storms	EX-CB84
S30	0.28	112.00	60.00	1.5000	Design_Storms	EX-CB87
S31	0.14	70.00	100.00	1.5000	Design_Storms	EX-CB90
S32	0.29	116.00	60.00	1.5000	Design_Storms	EX-CB92
S33	0.10	200.00	100.00	1.5000	Design_Storms	EX-CB95
S34	0.18	90.00	100.00	1.5000	Design_Storms	EX-CB96
S35	0.42	165.50	100.00	1.5000	Design_Storms	EX-CBMH117
S36	3.52	167.62	85.70	1.5000	Design_Storms	EX-CB14
S37	1.91	176.85	20.00	1.5000	Design_Storms	EX-STM43
S38	0.74	234.62	64.91	1.5000	Design_Storms	EX-CB132

\*\*\*\*\*  
 Node Summary  
 \*\*\*\*\*

Name	Type	Invert Elev.	Max. Depth	Ponded Area	External Inflow
HP01	JUNCTION	114.00	1.00	0.0	
HP-EX-CB10	JUNCTION	112.77	1.00	0.0	
HP-EX-CB100	JUNCTION	113.89	1.00	0.0	
HP-EX-CB102	JUNCTION	114.12	1.00	0.0	
HP-EX-CB102a	JUNCTION	114.00	1.00	0.0	
HP-EX-CB104	JUNCTION	114.06	1.00	0.0	
HP-EX-CB104a	JUNCTION	114.10	1.00	0.0	
HP-EX-CB106	JUNCTION	114.00	1.00	0.0	
HP-EX-CB110	JUNCTION	113.63	1.00	0.0	
HP-EX-CB113	JUNCTION	113.30	1.00	0.0	
HP-EX-CB116	JUNCTION	113.52	1.00	0.0	

4837 Albion Road - Hard Rock Ottawa (116111)  
 PCSWMM Model Results - Ex. Conditions (100-year, 3-hour Chicago Storm)

HP-EX-CB117	JUNCTION	113.50	1.00	0.0
HP-EX-CB123/124	JUNCTION	113.61	1.00	0.0
HP-EX-CB123/124a	JUNCTION	113.60	1.00	0.0
HP-EX-CB128	JUNCTION	113.96	1.00	0.0
HP-EX-CB131	JUNCTION	112.90	1.00	0.0
HP-EX-CB134	JUNCTION	113.51	1.00	0.0
HP-EX-CB137	JUNCTION	113.60	1.00	0.0
HP-EX-CB28	JUNCTION	114.00	1.00	0.0
HP-EX-CB30	JUNCTION	114.00	1.00	0.0
HP-EX-CB38	JUNCTION	113.90	1.00	0.0
HP-EX-CB40	JUNCTION	113.70	1.00	0.0
HP-EX-CB50	JUNCTION	114.03	1.00	0.0
HP-EX-CB50a	JUNCTION	114.09	1.00	0.0
HP-EX-CB52	JUNCTION	114.00	1.00	0.0
HP-EX-CB52a	JUNCTION	113.98	1.00	0.0
HP-EX-CB54	JUNCTION	113.98	1.00	0.0
HP-EX-CB54a	JUNCTION	113.95	1.00	0.0
HP-EX-CB58	JUNCTION	114.00	1.00	0.0
HP-EX-CB60	JUNCTION	113.96	1.00	0.0
HP-EX-CB62	JUNCTION	113.82	1.00	0.0
HP-EX-CB64	JUNCTION	113.98	1.00	0.0
HP-EX-CB66	JUNCTION	114.04	1.00	0.0
HP-EX-CB68	JUNCTION	114.14	1.00	0.0
HP-EX-CB72	JUNCTION	113.00	1.00	0.0
HP-EX-CB82	JUNCTION	114.05	1.00	0.0
HP-EX-CB84	JUNCTION	114.01	1.00	0.0
HP-EX-CB87	JUNCTION	113.95	1.00	0.0
HP-EX-CB90	JUNCTION	114.05	1.00	0.0
HP-EX-CB92	JUNCTION	113.95	1.00	0.0
HP-EX-CB95	JUNCTION	113.96	1.00	0.0
HP-EX-CB96	JUNCTION	113.97	1.00	0.0
HP-EX-CBMH117	JUNCTION	112.85	1.00	0.0
HP-EXMH102Aa	JUNCTION	114.15	1.00	0.0
HP-EX-STM43	JUNCTION	113.50	1.00	0.0
IF-EX-CB10	OUTFALL	0.00	0.00	0.0
IF-EX-CB100	OUTFALL	0.00	0.00	0.0
IF-EX-CB102	OUTFALL	0.00	0.00	0.0
IF-EX-CB104	OUTFALL	0.00	0.00	0.0
IF-EX-CB106	OUTFALL	0.00	0.00	0.0
IF-EX-CB110	OUTFALL	0.00	0.00	0.0
IF-EX-CB113	OUTFALL	0.00	0.00	0.0
IF-EX-CB116	OUTFALL	0.00	0.00	0.0
IF-EX-CB117	OUTFALL	0.00	0.00	0.0
IF-EX-CB121	OUTFALL	0.00	0.00	0.0
IF-EX-CB123/124	OUTFALL	0.00	0.00	0.0
IF-EX-CB128	OUTFALL	0.00	0.00	0.0

IF-EX-CB137	OUTFALL	0.00	0.00	0.0
IF-EX-CB28	OUTFALL	0.00	0.00	0.0
IF-EX-CB30	OUTFALL	0.00	0.00	0.0
IF-EX-CB38	OUTFALL	0.00	0.00	0.0
IF-EX-CB40	OUTFALL	0.00	0.00	0.0
IF-EX-CB50	OUTFALL	0.00	0.00	0.0
IF-EX-CB52	OUTFALL	0.00	0.00	0.0
IF-EX-CB54	OUTFALL	0.00	0.00	0.0
IF-EX-CB58	OUTFALL	0.00	0.00	0.0
IF-EX-CB64	OUTFALL	0.00	0.00	0.0
IF-EX-CB66	OUTFALL	0.00	0.00	0.0
IF-EX-CB68	OUTFALL	0.00	0.00	0.0
IF-EX-CB82	OUTFALL	0.00	0.00	0.0
IF-EX-CB84	OUTFALL	0.00	0.00	0.0
IF-EX-CB87	OUTFALL	0.00	0.00	0.0
IF-EX-CB90	OUTFALL	0.00	0.00	0.0
IF-EX-CB92	OUTFALL	0.00	0.00	0.0
IF-EX-CB95	OUTFALL	0.00	0.00	0.0
IF-EX-CB96	OUTFALL	0.00	0.00	0.0
IF-EX-CBMH117	OUTFALL	0.00	0.00	0.0
Major01	OUTFALL	112.87	1.00	0.0
Major02	OUTFALL	111.61	1.00	0.0
Major03	OUTFALL	106.80	1.04	0.0
Minor01	OUTFALL	102.95	0.75	0.0
EX-BLDG01	STORAGE	120.00	1.00	0.0
EX-CB10	STORAGE	111.51	2.10	0.0
EX-CB100	STORAGE	112.77	1.95	0.0
EX-CB102	STORAGE	112.69	1.94	0.0
EX-CB104	STORAGE	112.40	2.27	0.0
EX-CB106	STORAGE	112.31	2.40	0.0
EX-CB110	STORAGE	112.00	2.24	0.0
EX-CB113	STORAGE	112.00	2.26	0.0
EX-CB116	STORAGE	112.99	1.43	0.0
EX-CB117	STORAGE	112.09	2.36	0.0
EX-CB121	STORAGE	112.15	2.26	0.0
EX-CB123/124	STORAGE	111.80	2.56	0.0
EX-CB128	STORAGE	112.51	2.20	0.0
EX-CB132	STORAGE	108.88	3.43	0.0
EX-CB134	STORAGE	111.60	2.76	0.0
EX-CB137	STORAGE	112.00	2.41	0.0
EX-CB14	STORAGE	112.42	3.08	0.0
EX-CB28	STORAGE	112.43	2.22	0.0
EX-CB30	STORAGE	112.50	2.19	0.0
EX-CB38	STORAGE	112.86	1.77	0.0
EX-CB40	STORAGE	112.92	1.72	0.0
EX-CB50	STORAGE	112.34	2.37	0.0

Date: 04/24/20

4837 Albion Road - Hard Rock Ottawa (116111)  
 PCSWMM Model Results - Ex. Conditions (100-year, 3-hour Chicago Storm)

EX-CB52	STORAGE	112.44	2.27	0.0
EX-CB54	STORAGE	112.52	2.31	0.0
EX-CB58	STORAGE	112.44	2.29	0.0
EX-CB60	STORAGE	112.15	2.58	0.0
EX-CB62	STORAGE	112.64	2.12	0.0
EX-CB64	STORAGE	112.10	2.63	0.0
EX-CB66	STORAGE	112.37	2.29	0.0
EX-CB68	STORAGE	112.57	2.15	0.0
EX-CB72	STORAGE	111.18	2.49	0.0
EX-CB82	STORAGE	112.62	2.22	0.0
EX-CB84	STORAGE	112.12	2.53	0.0
EX-CB87	STORAGE	112.50	2.18	0.0
EX-CB90	STORAGE	112.51	2.28	0.0
EX-CB92	STORAGE	112.49	2.18	0.0
EX-CB95	STORAGE	112.45	2.22	0.0
EX-CB96	STORAGE	112.22	2.40	0.0
EX-CBMH117	STORAGE	111.26	2.48	0.0
EX-CBMH117a	STORAGE	111.26	1.48	0.0
EX-CBMH117b	STORAGE	109.47	3.53	0.0
EX-CBMH117c	STORAGE	109.12	3.88	0.0
EX-MH101	STORAGE	104.57	2.34	0.0
EX-MH101a	STORAGE	107.18	5.01	0.0
EX-MH101b	STORAGE	105.33	5.08	0.0
EX-MH102	STORAGE	109.38	4.69	0.0
EX-MH102A	STORAGE	112.42	1.74	0.0
EX-MH103	STORAGE	110.71	2.29	0.0
EX-MH104	STORAGE	110.65	3.25	0.0
EX-MH104a	STORAGE	110.32	3.64	0.0
EX-MH104b	STORAGE	109.82	4.24	0.0
EX-MH105	STORAGE	111.28	2.74	0.0
EX-MH106	STORAGE	112.15	1.84	0.0
EX-MH106a	STORAGE	111.61	3.39	0.0
EX-MH107	STORAGE	112.35	2.60	0.0
EX-MH107a	STORAGE	112.20	1.78	0.0
EX-MH108	STORAGE	111.32	2.35	0.0
EX-MH109	STORAGE	110.98	2.58	0.0
EX-MH109a	STORAGE	110.89	2.77	0.0
EX-MH109b	STORAGE	110.77	3.03	0.0
EX-MH110	STORAGE	112.08	2.83	0.0
EX-MH110a	STORAGE	112.08	1.83	0.0
EX-MH111	STORAGE	112.07	2.11	0.0
EX-MH112	STORAGE	112.15	2.79	0.0
EX-MH112a	STORAGE	112.10	2.02	0.0
EX-MH113	STORAGE	112.19	1.40	0.0
EX-MH113a	STORAGE	111.77	2.79	0.0
EX-MH113b	STORAGE	112.05	1.53	0.0

EX-MH113c	STORAGE	112.07	1.51	0.0
EX-MH114	STORAGE	112.51	1.19	0.0
EX-MH115	STORAGE	105.05	1.82	0.0
EX-MH116	STORAGE	105.50	2.37	0.0
EX-STM43	STORAGE	112.50	2.00	0.0
EX-STUB	STORAGE	111.38	2.28	0.0

\*\*\*\*\*  
 Link Summary  
 \*\*\*\*\*

Name	From Node	To Node	Type	Length	%Slope	Roughness
C1	EX-CB132	Major02	CONDUIT	3.0	-10.0504	0.0150
C10	EX-CB10	HP-EX-CB10	CONDUIT	3.0	-5.3409	0.0150
C100	EX-CB72	HP-EX-CB72	CONDUIT	3.0	-11.0672	0.0150
C11	HP-EX-CB10	EX-CB132	CONDUIT	3.0	55.7090	0.0150
C12	EX-MH116	Major03	CONDUIT	3.0	1.0001	0.0150
C13	EX-CB134	HP-EX-CB134	CONDUIT	3.0	-5.0063	0.0150
C136	HP-EX-CB72	HP-EX-CB131	CONDUIT	3.0	3.3352	0.0150
C14	EX-MH107	EX-CB28	CONDUIT	3.0	10.0504	0.0150
C15	EX-CBMH117	HP-EX-CBMH117	CONDUIT	3.0	-3.6691	0.0150
C16	HP-EX-CBMH117	EX-CB10	CONDUIT	3.0	8.0257	0.0150
C17	EX-CB82	HP-EX-CB82	CONDUIT	3.0	-7.0172	0.0150
C18	EX-CB87	HP-EX-CB87	CONDUIT	3.0	-9.0367	0.0150
C19	HP-EX-CB87	EX-CB90	CONDUIT	3.0	5.0063	0.0150
C2	HP-EX-CB134	EX-CB132	CONDUIT	3.0	107.8639	0.0150
C20	EX-STM43	HP-EX-STM43	CONDUIT	3.0	1.6669	0.0150
C21	EX-MH112	EX-CB58	CONDUIT	3.0	7.0172	0.0150
C22	HP-EX-CB131	Major01	CONDUIT	3.0	1.0001	0.0150
C24	EX-CB30	HP-EX-CB30	CONDUIT	3.0	-10.0504	0.0150
C25	HP-EX-CB30	EX-CB28	CONDUIT	3.0	11.7469	0.0150
C26	EX-CB28	HP-EX-CB28	CONDUIT	3.0	-11.7469	0.0150
C27	HP-EX-CB28	EX-CB96	CONDUIT	3.0	12.7695	0.0150
C28	EX-CB92	HP-EX-CB92	CONDUIT	3.0	-9.3743	0.0150
C29	HP-EX-CB92	EX-CB96	CONDUIT	3.0	11.0672	0.0150
C3	HP-EX-CB82	HP-EX-CB84	CONDUIT	3.0	1.3335	0.0150
C3_1	EX-CB128	HP-EX-CB128	CONDUIT	3.0	-8.3624	0.0150
C3_2	HP-EX-CB128	HP-EX-CB123/124	CONDUIT	3.0	11.7469	0.0150
C30	EX-CB90	HP-EX-CB90	CONDUIT	3.0	-8.3624	0.0150
C31	HP-EX-CB90	EX-CB96	CONDUIT	3.0	14.4829	0.0150
C32	EX-CB96	HP-EX-CB96	CONDUIT	3.0	-11.7469	0.0150
C33	HP-EX-CB96	EX-CB95	CONDUIT	3.0	10.0504	0.0150
C34	EX-CB95	HP-EX-CB95	CONDUIT	3.0	-9.7122	0.0150
C35	HP-EX-CB95	EX-CB128	CONDUIT	3.0	8.3624	0.0150
C36	EX-CB62	HP-EX-CB62	CONDUIT	3.0	-2.0004	0.0150



4837 Albion Road - Hard Rock Ottawa (116111)  
 PCSWMM Model Results - Ex. Conditions (100-year, 3-hour Chicago Storm)

C37	HP-EX-CB62	EX-CB60	CONDUIT	3.0	3.0014	0.0150
C38	EX-CB58	HP-EX-CB50	CONDUIT	3.0	-10.0504	0.0150
C39	HP-EX-CB50	EX-CB50	CONDUIT	3.0	10.7279	0.0150
C4	EX-CB40	HP-EX-CB40	CONDUIT	3.0	-2.0004	0.0150
C4_1	HP-EX-CB123/124	HP-EX-CB123/124a	CONDUIT	3.0	0.3333	0.0150
C4_2	HP-EX-CB123/124a	EX-CB137	CONDUIT	3.0	6.3461	0.0150
C40	EX-CB54	HP-EX-CB54	CONDUIT	3.0	-5.0063	0.0150
C41	HP-EX-CB54	EX-CB52	CONDUIT	3.0	9.0367	0.0150
C42	EX-CB50	HP-EX-CB52	CONDUIT	3.0	-9.7122	0.0150
C43	HP-EX-CB52	EX-CB52	CONDUIT	3.0	9.7122	0.0150
C44	EX-CB54	HP-EX-CB54a	CONDUIT	3.0	-4.0032	0.0150
C45	HP-EX-CB54a	EX-CB100	CONDUIT	3.0	7.6893	0.0150
C46	EX-CB52	HP-EX-CB52a	CONDUIT	3.0	-9.0367	0.0150
C47	HP-EX-CB52a	EX-CB102	CONDUIT	3.0	11.7469	0.0150
C48	EX-CB50	HP-EX-CB50a	CONDUIT	3.0	-12.7695	0.0150
C49	HP-EX-CB50a	EX-CB104	CONDUIT	3.0	14.1393	0.0150
C5	EX-CB137	HP-EX-CB137	CONDUIT	3.0	-6.3461	0.0150
C50	EX-CB58	HP-EX-CB58	CONDUIT	3.0	-9.0367	0.0150
C51	HP-EX-CB58	EX-CB106	CONDUIT	3.0	9.7122	0.0150
C52	EX-CB106	HP-EX-CB106	CONDUIT	3.0	-9.7122	0.0150
C53	HP-EX-CB106	EX-CB64	CONDUIT	3.0	9.0367	0.0150
C54	EX-CB104	HP-EX-CB104a	CONDUIT	3.0	-14.4829	0.0150
C55	HP-EX-CB104a	EX-CB66	CONDUIT	3.0	14.8270	0.0150
C56	EX-CB102	HP-EX-CB102a	CONDUIT	3.0	-12.4282	0.0150
C57	HP-EX-CB102a	EX-CB68	CONDUIT	3.0	9.3743	0.0150
C58	EX-CB100	HP-EX-CB100	CONDUIT	3.0	-5.6758	0.0150
C59	HP-EX-CB100	EX-CB102	CONDUIT	3.0	8.6994	0.0150
C6	HP-EX-CB84	HP-EX-CB137	CONDUIT	3.0	13.7961	0.0150
C60	EX-CB102	HP-EX-CB102	CONDUIT	3.0	-16.5557	0.0150
C61	HP-EX-CB102	EX-CB104	CONDUIT	3.0	15.1717	0.0150
C62	EX-CB104	HP-EX-CB104	CONDUIT	3.0	-13.1113	0.0150
C63	HP-EX-CB104	EX-CB106	CONDUIT	3.0	11.7469	0.0150
C64	EX-CB68	HP-EX-CB68	CONDUIT	3.0	-14.1393	0.0150
C65	HP-EX-CB68	EX-CB66	CONDUIT	3.0	16.2088	0.0150
C66	EX-CB66	HP-EX-CB66	CONDUIT	3.0	-12.7695	0.0150
C67	HP-EX-CB66	EX-CB64	CONDUIT	3.0	10.3889	0.0150
C68	EX-CB64	HP-EX-CB64	CONDUIT	3.0	-8.3624	0.0150
C69	HP-EX-CB64	EX-CB121	CONDUIT	3.0	19.0006	0.0150
C7	EX-CB84	HP-EX-CB84	CONDUIT	3.0	-12.0873	0.0150
C70	EX-CB116	HP-EX-CB116	CONDUIT	3.0	-3.0014	0.0150
C71	HP-EX-CB116	EX-CB117	CONDUIT	3.0	2.3340	0.0150
C72	EX-CB60	HP-EX-CB60	CONDUIT	3.0	-7.6893	0.0150
C73	HP-EX-CB60	HP-EX-CB117	CONDUIT	3.0	15.5168	0.0150
C76	EX-CB121	HP-EX-CB117	CONDUIT	3.0	-3.0014	0.0150
C77	EX-CB117	HP-EX-CB117	CONDUIT	3.0	-1.6669	0.0150
C79	HP-EX-CB117	EX-CB123/124	CONDUIT	3.0	4.6718	0.0150

C8	HP-EX-CB137	HP-EX-CB131	CONDUIT	3.0	23.9957	0.0150
C81	EX-CB123/124	HP-EX-CB123/124	CONDUIT	3.0	-8.3624	0.0150
C82	HP-EX-CB40	EX-CB38	CONDUIT	3.0	2.3340	0.0150
C83	EX-CB38	HP-EX-CB38	CONDUIT	3.0	-9.0367	0.0150
C84_1	HP-EX-CB38	HP-EX-STM43	CONDUIT	3.0	13.4535	0.0150
C84_2	HP-EX-STM43	EX-CB110	CONDUIT	3.0	8.6994	0.0150
C85	EX-CB110	HP-EX-CB110	CONDUIT	3.0	-13.1113	0.0150
C86	HP-EX-CB113	EX-CB110	CONDUIT	3.0	2.0004	0.0150
C87	EX-CB113	HP-EX-CB113	CONDUIT	3.0	-1.3335	0.0150
C88	HP-EX-CB110	EX-CB121	CONDUIT	3.0	7.0172	0.0150
C89	HP-EXMH102Aa	EX-CB82	CONDUIT	3.0	10.3889	0.0150
C9	EX-CB14	HP-EXMH102Aa	CONDUIT	3.0	-25.8199	0.0150
EXCBMH117a-117b	EX-CBMH117a	EX-CBMH117b	CONDUIT	30.4	5.8947	0.0130
EXCBMH117b-117c	EX-CBMH117b	EX-CBMH117c	CONDUIT	6.0	5.8975	0.0130
EX-Ditch	HP01	EX-CB14	CONDUIT	120.0	0.5000	0.0450
EXMH101-OUT	EX-MH101	Minor01	CONDUIT	80.9	2.0021	0.0130
EXMH102-101a	EX-MH102	EX-MH101a	CONDUIT	29.4	1.5648	0.0130
EXMH102a-102	EX-MH102A	EX-MH102	CONDUIT	58.6	0.8873	0.0130
EXMH103-102	EX-MH103	EX-MH102	CONDUIT	78.6	1.0942	0.0130
EXMH104-104a	EX-MH104	EX-MH104a	CONDUIT	25.0	1.3163	0.0130
EXMH104a-104b	EX-MH104a	EX-MH104b	CONDUIT	37.8	1.3186	0.0130
EXMH104b-102	EX-MH104b	EX-MH102	CONDUIT	2.5	1.3045	0.0130
EXMH105-104	EX-MH105	EX-MH104	CONDUIT	17.4	0.1722	0.0130
EXMH108-109	EX-MH108	EX-MH109	CONDUIT	30.7	1.1076	0.0130
EXMH109-109a	EX-MH109	EX-MH109a	CONDUIT	25.4	0.3344	0.0130
EXMH109a-109b	EX-MH109a	EX-MH109b	CONDUIT	36.0	0.3360	0.0130
EXMH109b-104	EX-MH109b	EX-MH104	CONDUIT	25.1	0.3349	0.0130
EXMH110-109	EX-MH110a	EX-MH109	CONDUIT	32.8	2.4673	0.0130
EXMH111-110	EX-MH111	EX-MH110	CONDUIT	24.7	-0.0405	0.0130
EXMH112-112a	EX-MH112	EX-MH112a	CONDUIT	58.1	0.0894	0.0130
EXMH112a-111	EX-MH112a	EX-MH111	CONDUIT	19.9	0.0907	0.0130
EXMH113-113c	EX-MH113	EX-MH113c	CONDUIT	32.4	0.3553	0.0130
EXMH113a-109	EX-MH113a	EX-MH109	CONDUIT	2.7	0.3704	0.0130
EXMH113b-113a	EX-MH113b	EX-MH113a	CONDUIT	79.2	0.3548	0.0130
EXMH113c-113b	EX-MH113c	EX-MH113b	CONDUIT	6.6	0.3622	0.0130
EXMH114-113	EX-MH114	EX-MH113	CONDUIT	64.4	0.4816	0.0130
EXMH115-101	EX-MH115	EX-MH101	CONDUIT	92.7	0.4962	0.0130
EXMH116-115	EX-MH116	EX-MH115	CONDUIT	91.3	0.4929	0.0130
EXMH117c-116	EX-CBMH117c	EX-MH116	CONDUIT	57.5	5.8993	0.0130
EXSTUB-108	EX-STUB	EX-MH108	CONDUIT	14.1	0.4255	0.0130
X-CB-103_(X-CB)	EX-CB100	EX-CB102	CONDUIT	12.9	0.4651	0.0130
X-CB-105_(X-CB)	EX-CB102	EX-CB104	CONDUIT	53.4	0.4120	0.0130
X-CB-107_(X-CB)	EX-CB104	EX-CB106	CONDUIT	32.4	0.2778	0.0130
X-CB-109_(X-CB)	EX-CB106	EX-MH112a	CONDUIT	3.2	0.9375	0.0130
X-CB-118_(X-CB)	EX-CB116	EX-CB117	CONDUIT	11.4	7.3001	0.0130
X-CB-129_(X-CB)	EX-CB128	EX-CB95	CONDUIT	7.2	0.6945	0.0130

4837 Albion Road - Hard Rock Ottawa (116111)  
 PCSWMM Model Results - Ex. Conditions (100-year, 3-hour Chicago Storm)

X-CB-89_(X-CB)	EX-CB87	EX-MH106a	CONDUIT	20.8	3.8008	0.0130
X-CB-91_(X-CB)	EX-CB90	EX-MH106a	CONDUIT	15.6	5.1350	0.0130
X-CB-94_(X-CB)	EX-CB92	EX-MH107a	CONDUIT	21.4	1.3553	0.0130
X-CB-97_(X-CB)	EX-CB95	EX-CB96	CONDUIT	25.5	0.7059	0.0130
X-CB-98_(X-CB)	EX-CB96	EX-MH107a	CONDUIT	15.6	0.1282	0.0130
X-STM-11_(X-STM)	EX-CB10	EX-CBMH17	CONDUIT	40.1	0.5985	0.0130
X-STM-13_(1)_(X-STM)	EX-MH101a	EX-MH101b	CONDUIT	30.1	1.3955	0.0130
X-STM-13_(X-STM)	EX-MH101b	EX-MH101	CONDUIT	32.6	2.2705	0.0130
X-STM-25_(X-STM)	1 EX-MH106	EX-MH106a	CONDUIT	33.3	1.6218	0.0130
X-STM-27_(X-STM)	1 EX-MH107	EX-MH107a	CONDUIT	50.2	0.2988	0.0130
X-STM-27_(X-STM)	2 EX-MH107a	EX-MH106	CONDUIT	11.9	0.1681	0.0130
X-STM-29_(X-STM)	EX-CB28	EX-MH107	CONDUIT	14.8	0.0676	0.0130
X-STM-31_(X-STM)	EX-CB30	EX-MH107	CONDUIT	21.7	0.4608	0.0130
X-STM-51_(X-STM)	EX-CB50	EX-MH112	CONDUIT	22.1	0.0905	0.0130
X-STM-53_(X-STM)	EX-CB52	EX-CB50	CONDUIT	55.0	0.1818	0.0130
X-STM-55_(X-STM)	EX-CB54	EX-CB52	CONDUIT	13.1	0.6107	0.0130
X-STM-59_(X-STM)	EX-CB58	EX-MH112	CONDUIT	11.9	1.0085	0.0130
X-STM-61_(X-STM)	EX-CB60	EX-MH111	CONDUIT	15.3	0.4575	0.0130
X-STM-63_(X-STM)	EX-CB62	EX-CB60	CONDUIT	7.2	0.5556	0.0130
X-STM-65_(X-STM)	EX-CB64	EX-MH110	CONDUIT	11.0	0.1818	0.0130
X-STM-67_(X-STM)	EX-CB66	EX-CB64	CONDUIT	36.2	0.7459	0.0130
X-STM-69_(X-STM)	EX-CB68	EX-CB66	CONDUIT	49.6	0.3629	0.0130
OR1	EX-STM43	EX-MH113	ORIFICE			
OR2	EX-CB14	EX-MH102A	ORIFICE			
OR3	EX-CBMH17	EX-CBMH17a	ORIFICE			
OR4	EX-MH110	EX-MH110a	ORIFICE			
X-CB-112_(X-CB)	EX-CB110	EX-MH113c	ORIFICE			
X-CB-115_(X-CB)	EX-CB113	EX-MH113b	ORIFICE			
X-CB-120_(X-CB)	EX-CB117	EX-MH113a	ORIFICE			
X-CB-122_(X-CB)	EX-CB121	EX-MH113a	ORIFICE			
X-CB-127_(X-CB)	EX-CB123/124	EX-MH109a	ORIFICE			
X-CB-131_(X-CB)	EX-CB132	EX-CBMH17c	ORIFICE			
X-CB-133_(X-CB)	EX-CB134	EX-CBMH17b	ORIFICE			
X-CB-135_(X-CB)	EX-CB137	EX-MH109b	ORIFICE			
X-CB-83_(X-CB)	EX-CB82	EX-MH104b	ORIFICE			
X-CB-86_(X-CB)	EX-CB84	EX-MH104a	ORIFICE			
X-STM-25_(X-STM)	2 EX-MH106a	EX-MH105	ORIFICE			
X-STM-39_(X-STM)	EX-CB38	EX-MH114	ORIFICE			
X-STM-41_(X-STM)	EX-CB40	EX-MH114	ORIFICE			
X-STM-73_(X-STM)	EX-CB72	EX-MH103	ORIFICE			
EX-BLDG01-OUT	EX-BLDG01	EX-STUB	OUTLET			
INFIL-EX-CB10	EX-CB10	IF-EX-CB10	OUTLET			
INFIL-EX-CB100	EX-CB100	IF-EX-CB100	OUTLET			
INFIL-EX-CB102	EX-CB102	IF-EX-CB102	OUTLET			
INFIL-EX-CB104	EX-CB104	IF-EX-CB104	OUTLET			
INFIL-EX-CB106	EX-CB106	IF-EX-CB106	OUTLET			

INFIL-EX-CB110	EX-CB110	IF-EX-CB110	OUTLET			
INFIL-EX-CB113	EX-CB113	IF-EX-CB113	OUTLET			
INFIL-EX-CB116	EX-CB116	IF-EX-CB116	OUTLET			
INFIL-EX-CB117	EX-CB117	IF-EX-CB117	OUTLET			
INFIL-EX-CB121	EX-CB121	IF-EX-CB121	OUTLET			
INFIL-EX-CB123/124	EX-CB123/124	IF-EX-CB123/124	OUTLET			
INFIL-EX-CB128	EX-CB128	IF-EX-CB128	OUTLET			
INFIL-EX-CB137	EX-CB137	IF-EX-CB137	OUTLET			
INFIL-EX-CB28	EX-CB28	IF-EX-CB28	OUTLET			
INFIL-EX-CB30	EX-CB30	IF-EX-CB30	OUTLET			
INFIL-EX-CB38	EX-CB38	IF-EX-CB38	OUTLET			
INFIL-EX-CB40	EX-CB40	IF-EX-CB40	OUTLET			
INFIL-EX-CB50	EX-CB50	IF-EX-CB50	OUTLET			
INFIL-EX-CB52	EX-CB52	IF-EX-CB52	OUTLET			
INFIL-EX-CB54	EX-CB54	IF-EX-CB54	OUTLET			
INFIL-EX-CB58	EX-CB58	IF-EX-CB58	OUTLET			
INFIL-EX-CB64	EX-CB64	IF-EX-CB64	OUTLET			
INFIL-EX-CB66	EX-CB66	IF-EX-CB66	OUTLET			
INFIL-EX-CB68	EX-CB68	IF-EX-CB68	OUTLET			
INFIL-EX-CB82	EX-CB82	IF-EX-CB82	OUTLET			
INFIL-EX-CB84	EX-CB84	IF-EX-CB84	OUTLET			
INFIL-EX-CB87	EX-CB87	IF-EX-CB87	OUTLET			
INFIL-EX-CB90	EX-CB90	IF-EX-CB90	OUTLET			
INFIL-EX-CB92	EX-CB92	IF-EX-CB92	OUTLET			
INFIL-EX-CB95	EX-CB95	IF-EX-CB95	OUTLET			
INFIL-EX-CB96	EX-CB96	IF-EX-CB96	OUTLET			
INFIL-EX-CBMH17	EX-CBMH17	IF-EX-CBMH17	OUTLET			

\*\*\*\*\*  
 Cross Section Summary  
 \*\*\*\*\*

Conduit	Shape	Full Depth	Full Area	Hyd. Rad.	Max. Width	No. of Barrels	Full Flow
C1	RECT_OPEN	1.00	3.00	0.60	3.00	1	45107.44
C10	RECT_OPEN	1.00	3.00	0.60	3.00	1	32882.56
C100	RECT_OPEN	1.00	3.00	0.60	3.00	1	47334.20
C11	RECT_OPEN	1.00	3.00	0.60	3.00	1	106198.78
C12	RECT_OPEN	1.00	3.00	0.60	3.00	1	14228.79
C13	RECT_OPEN	1.00	3.00	0.60	3.00	1	31835.65
C136	RECT_OPEN	1.00	3.00	0.60	3.00	1	25984.66
C14	RECT_OPEN	1.00	3.00	0.60	3.00	1	45107.44
C15	RECT_OPEN	1.00	3.00	0.60	3.00	1	27254.53
C16	RECT_OPEN	1.00	3.00	0.60	3.00	1	40308.73
C17	RECT_OPEN	1.00	3.00	0.60	3.00	1	37691.14

Date: 04/24/20

4837 Albion Road - Hard Rock Ottawa (116111)  
 PCSWMM Model Results - Ex. Conditions (100-year, 3-hour Chicago Storm)

C18	RECT_OPEN	1.00	3.00	0.60	3.00	1 42772.17
C19	RECT_OPEN	1.00	3.00	0.60	3.00	1 31835.65
C2	RECT_OPEN	1.00	3.00	0.60	3.00	1 147772.96
C20	RECT_OPEN	1.00	3.00	0.60	3.00	1 18370.10
C21	RECT_OPEN	1.00	3.00	0.60	3.00	1 37691.14
C22	RECT_OPEN	1.00	3.00	0.60	3.00	1 14228.79
C24	RECT_OPEN	1.00	3.00	0.60	3.00	1 45107.44
C25	RECT_OPEN	1.00	3.00	0.60	3.00	1 48766.13
C26	RECT_OPEN	1.00	3.00	0.60	3.00	1 48766.13
C27	RECT_OPEN	1.00	3.00	0.60	3.00	1 50844.53
C28	RECT_OPEN	1.00	3.00	0.60	3.00	1 43563.76
C29	RECT_OPEN	1.00	3.00	0.60	3.00	1 47334.20
C3	RECT_OPEN	1.00	3.00	0.60	3.00	1 16430.31
C3_1	RECT_OPEN	1.00	3.00	0.60	3.00	1 41145.56
C3_2	RECT_OPEN	1.00	3.00	0.60	3.00	1 48766.13
C30	RECT_OPEN	1.00	3.00	0.60	3.00	1 41145.56
C31	RECT_OPEN	1.00	3.00	0.60	3.00	1 54148.25
C32	RECT_OPEN	1.00	3.00	0.60	3.00	1 48766.13
C33	RECT_OPEN	1.00	3.00	0.60	3.00	1 45107.44
C34	RECT_OPEN	1.00	3.00	0.60	3.00	1 44341.94
C35	RECT_OPEN	1.00	3.00	0.60	3.00	1 41145.56
C36	RECT_OPEN	1.00	3.00	0.60	3.00	1 20124.05
C37	RECT_OPEN	1.00	3.00	0.60	3.00	1 24649.91
C38	RECT_OPEN	1.00	3.00	0.60	3.00	1 45107.44
C39	RECT_OPEN	1.00	3.00	0.60	3.00	1 46602.99
C4	RECT_OPEN	1.00	3.00	0.60	3.00	1 20124.05
C4_1	RECT_OPEN	1.00	3.00	0.60	3.00	1 8214.81
C4_2	RECT_OPEN	1.00	3.00	0.60	3.00	1 35843.43
C40	RECT_OPEN	1.00	3.00	0.60	3.00	1 31835.65
C41	RECT_OPEN	1.00	3.00	0.60	3.00	1 42772.17
C42	RECT_OPEN	1.00	3.00	0.60	3.00	1 44341.94
C43	RECT_OPEN	1.00	3.00	0.60	3.00	1 44341.94
C44	RECT_OPEN	1.00	3.00	0.60	3.00	1 28468.25
C45	RECT_OPEN	1.00	3.00	0.60	3.00	1 39454.84
C46	RECT_OPEN	1.00	3.00	0.60	3.00	1 42772.17
C47	RECT_OPEN	1.00	3.00	0.60	3.00	1 48766.13
C48	RECT_OPEN	1.00	3.00	0.60	3.00	1 50844.53
C49	RECT_OPEN	1.00	3.00	0.60	3.00	1 53502.02
C5	RECT_OPEN	1.00	3.00	0.60	3.00	1 35843.43
C50	RECT_OPEN	1.00	3.00	0.60	3.00	1 42772.17
C51	RECT_OPEN	1.00	3.00	0.60	3.00	1 44341.94
C52	RECT_OPEN	1.00	3.00	0.60	3.00	1 44341.94
C53	RECT_OPEN	1.00	3.00	0.60	3.00	1 42772.17
C54	RECT_OPEN	1.00	3.00	0.60	3.00	1 54148.25
C55	RECT_OPEN	1.00	3.00	0.60	3.00	1 54787.78
C56	RECT_OPEN	1.00	3.00	0.60	3.00	1 50160.45

C57	RECT_OPEN	1.00	3.00	0.60	3.00	1 43563.76
C58	RECT_OPEN	1.00	3.00	0.60	3.00	1 33897.68
C59	RECT_OPEN	1.00	3.00	0.60	3.00	1 41966.39
C6	RECT_OPEN	1.00	3.00	0.60	3.00	1 52848.83
C60	RECT_OPEN	1.00	3.00	0.60	3.00	1 57893.56
C61	RECT_OPEN	1.00	3.00	0.60	3.00	1 55420.88
C62	RECT_OPEN	1.00	3.00	0.60	3.00	1 51520.40
C63	RECT_OPEN	1.00	3.00	0.60	3.00	1 48766.13
C64	RECT_OPEN	1.00	3.00	0.60	3.00	1 53502.02
C65	RECT_OPEN	1.00	3.00	0.60	3.00	1 57283.91
C66	RECT_OPEN	1.00	3.00	0.60	3.00	1 50844.53
C67	RECT_OPEN	1.00	3.00	0.60	3.00	1 45860.92
C68	RECT_OPEN	1.00	3.00	0.60	3.00	1 41145.56
C69	RECT_OPEN	1.00	3.00	0.60	3.00	1 62021.32
C7	RECT_OPEN	1.00	3.00	0.60	3.00	1 49467.78
C70	RECT_OPEN	1.00	3.00	0.60	3.00	1 24649.91
C71	RECT_OPEN	1.00	3.00	0.60	3.00	1 21737.24
C72	RECT_OPEN	1.00	3.00	0.60	3.00	1 39454.84
C73	RECT_OPEN	1.00	3.00	0.60	3.00	1 56047.78
C76	RECT_OPEN	1.00	3.00	0.60	3.00	1 24649.91
C77	RECT_OPEN	1.00	3.00	0.60	3.00	1 18370.10
C79	RECT_OPEN	1.00	3.00	0.60	3.00	1 30753.68
C8	RECT_OPEN	1.00	3.00	0.60	3.00	1 69698.53
C81	RECT_OPEN	1.00	3.00	0.60	3.00	1 41145.56
C82	RECT_OPEN	1.00	3.00	0.60	3.00	1 21737.24
C83	RECT_OPEN	1.00	3.00	0.60	3.00	1 42772.17
C84_1	RECT_OPEN	1.00	3.00	0.60	3.00	1 52188.39
C84_2	RECT_OPEN	1.00	3.00	0.60	3.00	1 41966.39
C85	RECT_OPEN	1.00	3.00	0.60	3.00	1 51520.40
C86	RECT_OPEN	1.00	3.00	0.60	3.00	1 20124.05
C87	RECT_OPEN	1.00	3.00	0.60	3.00	1 16430.31
C88	RECT_OPEN	1.00	3.00	0.60	3.00	1 37691.14
C89	RECT_OPEN	1.00	2.00	0.50	2.00	1 27074.72
C9	RECT_OPEN	1.00	2.00	0.50	2.00	1 42683.05
EXCBMH117a-117b	CIRCULAR	0.25	0.05	0.06	0.25	1 144.39
EXCBMH117b-117c	CIRCULAR	0.25	0.05	0.06	0.25	1 144.42
EX-Ditch	TRAPEZOIDAL	1.00	3.10	0.48	6.10	1 2996.92
EXMH101-OUT	CIRCULAR	0.75	0.44	0.19	0.75	1 1575.34
EXMH102-101a	CIRCULAR	0.75	0.44	0.19	0.75	1 1392.71
EXMH102a-102	CIRCULAR	0.30	0.07	0.07	0.30	1 91.09
EXMH103-102	CIRCULAR	0.30	0.07	0.07	0.30	1 101.16
EXMH104-104a	CIRCULAR	0.60	0.28	0.15	0.60	1 704.49
EXMH104a-104b	CIRCULAR	0.60	0.28	0.15	0.60	1 705.10
EXMH104b-102	CIRCULAR	0.60	0.28	0.15	0.60	1 701.32
EXMH105-104	CIRCULAR	0.45	0.16	0.11	0.45	1 118.32
EXMH108-109	CIRCULAR	0.38	0.11	0.09	0.38	1 184.53

Date: 04/24/20

4837 Albion Road - Hard Rock Ottawa (116111)  
 PCSWMM Model Results - Ex. Conditions (100-year, 3-hour Chicago Storm)

EXMH109-109a	CIRCULAR	0.60	0.28	0.15	0.60	1	355.11
EXMH109a-109b	CIRCULAR	0.60	0.28	0.15	0.60	1	355.94
EXMH109b-104	CIRCULAR	0.60	0.28	0.15	0.60	1	355.37
EXMH110-109	CIRCULAR	0.30	0.07	0.07	0.30	1	151.90
EXMH111-110	CIRCULAR	0.30	0.07	0.07	0.30	1	19.46
EXMH112-112a	CIRCULAR	0.30	0.07	0.07	0.30	1	28.92
EXMH112a-111	CIRCULAR	0.30	0.07	0.07	0.30	1	29.12
EXMH113-113c	CIRCULAR	0.38	0.11	0.09	0.38	1	104.51
EXMH113a-109	CIRCULAR	0.38	0.11	0.09	0.38	1	106.71
EXMH113b-113a	CIRCULAR	0.38	0.11	0.09	0.38	1	104.44
EXMH113c-113b	CIRCULAR	0.38	0.11	0.09	0.38	1	105.52
EXMH114-113	CIRCULAR	0.25	0.05	0.06	0.25	1	41.27
EXMH115-101	CIRCULAR	0.30	0.07	0.07	0.30	1	68.12
EXMH116-115	CIRCULAR	0.30	0.07	0.07	0.30	1	67.89
EXMH117c-116	CIRCULAR	0.25	0.05	0.06	0.25	1	144.45
EXSTUB-108	CIRCULAR	0.38	0.11	0.09	0.38	1	114.38
X-CB-103_(X-CB)	CIRCULAR	0.25	0.05	0.06	0.25	1	40.56
X-CB-105_(X-CB)	CIRCULAR	0.25	0.05	0.06	0.25	1	38.17
X-CB-107_(X-CB)	CIRCULAR	0.25	0.05	0.06	0.25	1	31.34
X-CB-109_(X-CB)	CIRCULAR	0.25	0.05	0.06	0.25	1	57.58
X-CB-118_(X-CB)	CIRCULAR	0.20	0.03	0.05	0.20	1	88.62
X-CB-129_(X-CB)	CIRCULAR	0.20	0.03	0.05	0.20	1	27.33
X-CB-89_(X-CB)	CIRCULAR	0.20	0.03	0.05	0.20	1	63.95
X-CB-91_(X-CB)	CIRCULAR	0.20	0.03	0.05	0.20	1	74.33
X-CB-94_(X-CB)	CIRCULAR	0.20	0.03	0.05	0.20	1	38.18
X-CB-97_(X-CB)	CIRCULAR	0.30	0.07	0.07	0.30	1	81.25
X-CB-98_(X-CB)	CIRCULAR	0.30	0.07	0.07	0.30	1	34.63
X-STM-11_(X-STM)	CIRCULAR	0.25	0.05	0.06	0.25	1	46.01
X-STM-13_1_(X-STM)	CIRCULAR	0.75	0.44	0.19	0.75	1	1315.20
X-STM-13_(X-STM)	CIRCULAR	0.75	0.44	0.19	0.75	1	1677.62
X-STM-25_(X-STM)_1	CIRCULAR	0.45	0.16	0.11	0.45	1	363.11
X-STM-27_(X-STM)_1	CIRCULAR	0.30	0.07	0.07	0.30	1	52.86
X-STM-27_(X-STM)_2	CIRCULAR	0.30	0.07	0.07	0.30	1	39.65
X-STM-29_(X-STM)	CIRCULAR	0.30	0.07	0.07	0.30	1	25.14
X-STM-31_(X-STM)	CIRCULAR	0.20	0.03	0.05	0.20	1	22.27
X-STM-51_(X-STM)	CIRCULAR	0.30	0.07	0.07	0.30	1	29.09
X-STM-53_(X-STM)	CIRCULAR	0.30	0.07	0.07	0.30	1	41.24
X-STM-55_(X-STM)	CIRCULAR	0.25	0.05	0.06	0.25	1	46.48
X-STM-59_(X-STM)	CIRCULAR	0.20	0.03	0.05	0.20	1	32.94
X-STM-61_(X-STM)	CIRCULAR	0.25	0.05	0.06	0.25	1	40.23
X-STM-63_(X-STM)	CIRCULAR	0.20	0.03	0.05	0.20	1	24.45
X-STM-65_(X-STM)	CIRCULAR	0.25	0.05	0.06	0.25	1	25.36
X-STM-67_(X-STM)	CIRCULAR	0.25	0.05	0.06	0.25	1	51.36
X-STM-69_(X-STM)	CIRCULAR	0.25	0.05	0.06	0.25	1	35.83

\*\*\*\*\*  
 NOTE: The summary statistics displayed in this report are based on results found at every computational time step, not just on results from each reporting time step.  
 \*\*\*\*\*

\*\*\*\*\*  
 Analysis Options  
 \*\*\*\*\*  
 Flow Units ..... LPS  
 Process Models:  
 Rainfall/Runoff ..... YES  
 RDII ..... NO  
 Snowmelt ..... NO  
 Groundwater ..... NO  
 Flow Routing ..... YES  
 Ponding Allowed ..... NO  
 Water Quality ..... NO  
 Infiltration Method ..... HORTON  
 Flow Routing Method ..... DYNWAVE  
 Surge Method ..... EXTRAN  
 Starting Date ..... 03/02/2020 00:00:00  
 Ending Date ..... 03/03/2020 00:00:00  
 Antecedent Dry Days ..... 0.0  
 Report Time Step ..... 00:01:00  
 Wet Time Step ..... 00:05:00  
 Dry Time Step ..... 00:05:00  
 Routing Time Step ..... 2.00 sec  
 Variable Time Step ..... YES  
 Maximum Trials ..... 8  
 Number of Threads ..... 4  
 Head Tolerance ..... 0.001500 m

	Volume	Depth
Runoff Quantity Continuity	hectare-m	mm
*****	-----	-----
Total Precipitation	0.988	71.667
Evaporation Loss	0.000	0.000
Infiltration Loss	0.130	9.408
Surface Runoff	0.848	61.508
Final Storage	0.016	1.170
Continuity Error (%)	-0.585	

4837 Albion Road - Hard Rock Ottawa (116111)  
 PCSWMM Model Results - Ex. Conditions (100-year, 3-hour Chicago Storm)

	Volume hectare-m	Volume 10 <sup>6</sup> ltr
Flow Routing Continuity		
Dry Weather Inflow	0.000	0.000
Wet Weather Inflow	0.848	8.478
Groundwater Inflow	0.000	0.000
RDII Inflow	0.000	0.000
External Inflow	0.002	0.016
External Outflow	0.850	8.496
Flooding Loss	0.000	0.000
Evaporation Loss	0.000	0.000
Exfiltration Loss	0.000	0.000
Initial Stored Volume	0.000	0.000
Final Stored Volume	0.000	0.001
Continuity Error (%)	-0.028	

\*\*\*\*\*  
 Time-Step Critical Elements  
 \*\*\*\*\*  
 Link EXMH104b-102 (91.76%)

\*\*\*\*\*  
 Highest Flow Instability Indexes  
 \*\*\*\*\*  
 Link EX-BLDG01-OUT (15)  
 Link INFIL-EX-CB123/124 (11)  
 Link INFIL-EX-CB10 (5)  
 Link INFIL-EX-CB82 (4)  
 Link INFIL-EX-CBMH117 (4)

\*\*\*\*\*  
 Routing Time Step Summary  
 \*\*\*\*\*  
 Minimum Time Step : 0.16 sec  
 Average Time Step : 0.95 sec  
 Maximum Time Step : 2.00 sec  
 Percent in Steady State : 0.00  
 Average Iterations per Step : 2.03  
 Percent Not Converging : 0.22

\*\*\*\*\*  
 Subcatchment Runoff Summary

Subcatchment	Total Precip mm	Total Runon mm	Total Evap mm	Total Infil mm	Imperv Runoff mm	Perv Runoff mm	Total Runoff mm	Total Runoff 10 <sup>6</sup> ltr	Peak Runoff LPS	Runoff Coeff
BLDG	71.67	0.00	0.00	0.00	72.27	0.00	72.27	0.62	413.51	1.008
S01	71.67	0.00	0.00	0.00	70.49	0.00	70.49	0.32	223.17	0.984
S02	71.67	0.00	0.00	0.00	70.17	0.00	70.17	0.04	29.76	0.979
S03	71.67	0.00	0.00	0.00	70.30	0.00	70.30	0.13	89.28	0.981
S04	71.67	0.00	0.00	0.00	70.24	0.00	70.24	0.15	109.12	0.980
S05	71.67	0.00	0.00	0.00	70.22	0.00	70.22	0.12	84.32	0.980
S06	71.67	0.00	0.00	0.00	70.18	0.00	70.18	0.15	104.16	0.979
S07	71.67	0.00	0.00	0.00	70.24	0.00	70.24	0.21	148.80	0.980
S08	71.67	0.00	0.00	0.00	70.30	0.00	70.30	0.06	44.64	0.981
S09	71.67	0.00	0.00	0.00	70.17	0.00	70.17	0.03	19.84	0.979
S1	71.67	0.00	0.00	0.00	70.73	0.00	70.73	0.03	19.47	0.987
S10	71.67	0.00	0.00	0.00	70.22	0.00	70.22	0.06	39.68	0.980
S11	71.67	0.00	0.00	0.00	70.65	0.00	70.65	0.49	346.59	0.986
S12	71.67	0.00	0.00	0.00	70.17	0.00	70.17	0.07	49.60	0.979
S13	71.67	0.00	0.00	0.00	70.46	0.00	70.46	0.07	49.60	0.983
S14	71.67	0.00	0.00	0.00	70.34	0.00	70.34	0.06	44.64	0.981
S15	71.67	0.00	0.00	0.00	70.39	0.00	70.39	0.16	114.08	0.982
S16	71.67	0.00	0.00	17.93	42.18	11.30	53.48	0.20	162.64	0.746
S17	71.67	0.00	0.00	0.00	70.17	0.00	70.17	0.02	14.88	0.979
S18	71.67	0.00	0.00	0.00	70.17	0.00	70.17	0.02	14.88	0.979
S19	71.67	0.00	0.00	0.00	70.28	0.00	70.28	0.18	124.00	0.981
S20	71.67	0.00	0.00	0.00	70.24	0.00	70.24	0.14	99.20	0.980
S21	71.67	0.00	0.00	0.00	70.17	0.00	70.17	0.06	39.68	0.979
S22	71.67	0.00	0.00	0.00	70.30	0.00	70.30	0.13	94.24	0.981
S23	71.67	0.00	0.00	0.00	70.17	0.00	70.17	0.05	34.72	0.979
S24	71.67	0.00	0.00	0.00	70.17	0.00	70.17	0.08	54.56	0.979
S25	71.67	0.00	0.00	0.00	70.17	0.00	70.17	0.08	54.56	0.979
S26	71.67	0.00	0.00	0.00	70.30	0.00	70.30	0.13	94.24	0.981
S27	71.67	0.00	0.00	0.00	70.19	0.00	70.19	0.10	69.44	0.979
S28	71.67	0.00	0.00	0.00	70.48	0.00	70.48	0.19	133.90	0.983
S29	71.67	0.00	0.00	0.00	70.44	0.00	70.44	0.16	114.07	0.983
S30	71.67	0.00	0.00	17.93	42.18	11.30	53.48	0.15	119.84	0.746
S31	71.67	0.00	0.00	0.00	70.39	0.00	70.39	0.10	69.44	0.982
S32	71.67	0.00	0.00	17.93	42.18	11.30	53.48	0.16	124.12	0.746
S33	71.67	0.00	0.00	0.00	70.17	0.00	70.17	0.07	49.60	0.979
S34	71.67	0.00	0.00	0.00	70.39	0.00	70.39	0.13	89.28	0.982
S35	71.67	0.00	0.00	0.00	70.46	0.00	70.46	0.30	208.30	0.983
S36	71.67	0.00	0.00	6.69	60.57	3.64	64.21	2.26	1483.97	0.896
S37	71.67	0.00	0.00	40.53	14.08	16.99	31.07	0.59	306.07	0.434

4837 Albion Road - Hard Rock Ottawa (116111)  
 PCSWMM Model Results - Ex. Conditions (100-year, 3-hour Chicago Storm)

S38 71.67 0.00 0.00 15.77 45.70 9.84 55.53 0.41 319.62 0.775

\*\*\*\*\*  
 Node Depth Summary  
 \*\*\*\*\*

Node	Type	Average Depth Meters	Maximum Depth Meters	Maximum HGL Meters	Time of Max Occurrence days hr:min	Reported Max Depth Meters
HP01	JUNCTION	0.03	0.48	114.48	0 01:11	0.48
HP-EX-CB10	JUNCTION	0.00	0.04	112.81	0 01:06	0.03
HP-EX-CB100	JUNCTION	0.02	0.09	113.98	0 01:14	0.09
HP-EX-CB102	JUNCTION	0.00	0.00	114.12	0 00:00	0.00
HP-EX-CB102a	JUNCTION	0.00	0.00	114.00	0 00:00	0.00
HP-EX-CB104	JUNCTION	0.00	0.00	114.06	0 00:00	0.00
HP-EX-CB104a	JUNCTION	0.00	0.00	114.10	0 00:00	0.00
HP-EX-CB106	JUNCTION	0.00	0.00	114.00	0 00:00	0.00
HP-EX-CB110	JUNCTION	0.00	0.33	113.96	0 01:11	0.30
HP-EX-CB113	JUNCTION	0.05	0.62	113.92	0 01:10	0.60
HP-EX-CB116	JUNCTION	0.02	0.41	113.93	0 01:10	0.36
HP-EX-CB117	JUNCTION	0.02	0.39	113.89	0 01:10	0.36
HP-EX-CB123/124	JUNCTION	0.00	0.23	113.84	0 01:10	0.20
HP-EX-CB123/124a	JUNCTION	0.00	0.21	113.81	0 01:10	0.14
HP-EX-CB128	JUNCTION	0.00	0.00	113.96	0 00:00	0.00
HP-EX-CB131	JUNCTION	0.01	0.35	113.25	0 01:10	0.28
HP-EX-CB134	JUNCTION	0.00	0.00	113.51	0 01:09	0.00
HP-EX-CB137	JUNCTION	0.00	0.13	113.73	0 01:09	0.11
HP-EX-CB28	JUNCTION	0.00	0.00	114.00	0 00:00	0.00
HP-EX-CB30	JUNCTION	0.00	0.00	114.00	0 00:00	0.00
HP-EX-CB38	JUNCTION	0.00	0.00	113.90	0 01:10	0.00
HP-EX-CB40	JUNCTION	0.00	0.00	113.70	0 00:00	0.00
HP-EX-CB50	JUNCTION	0.00	0.00	114.03	0 00:00	0.00
HP-EX-CB50a	JUNCTION	0.00	0.00	114.09	0 00:00	0.00
HP-EX-CB52	JUNCTION	0.00	0.00	114.00	0 00:00	0.00
HP-EX-CB52a	JUNCTION	0.00	0.00	113.98	0 01:14	0.00
HP-EX-CB54	JUNCTION	0.00	0.01	113.99	0 01:13	0.00
HP-EX-CB54a	JUNCTION	0.00	0.03	113.98	0 01:14	0.03
HP-EX-CB58	JUNCTION	0.00	0.00	114.00	0 05:56	0.00
HP-EX-CB60	JUNCTION	0.00	0.00	113.96	0 00:00	0.00
HP-EX-CB62	JUNCTION	0.05	0.14	113.96	0 03:12	0.14
HP-EX-CB64	JUNCTION	0.00	0.00	113.98	0 00:00	0.00
HP-EX-CB66	JUNCTION	0.00	0.00	114.04	0 00:00	0.00
HP-EX-CB68	JUNCTION	0.00	0.00	114.14	0 00:00	0.00

HP-EX-CB72	JUNCTION	0.00	0.28	113.28	0 01:10	0.21
HP-EX-CB82	JUNCTION	0.01	0.19	114.24	0 01:04	0.18
HP-EX-CB84	JUNCTION	0.00	0.16	114.17	0 01:09	0.09
HP-EX-CB87	JUNCTION	0.00	0.00	113.95	0 00:00	0.00
HP-EX-CB90	JUNCTION	0.00	0.00	114.05	0 00:00	0.00
HP-EX-CB92	JUNCTION	0.00	0.00	113.95	0 00:00	0.00
HP-EX-CB95	JUNCTION	0.00	0.00	113.96	0 00:00	0.00
HP-EX-CB96	JUNCTION	0.00	0.00	113.97	0 00:00	0.00
HP-EX-CBMH117	JUNCTION	0.00	0.04	112.89	0 01:05	0.03
HP-EXMH102Aa	JUNCTION	0.00	0.18	114.33	0 01:11	0.18
HP-EX-STM43	JUNCTION	0.01	0.40	113.90	0 01:09	0.37
IF-EX-CB10	OUTFALL	0.00	0.00	0.00	0 00:00	0.00
IF-EX-CB100	OUTFALL	0.00	0.00	0.00	0 00:00	0.00
IF-EX-CB102	OUTFALL	0.00	0.00	0.00	0 00:00	0.00
IF-EX-CB104	OUTFALL	0.00	0.00	0.00	0 00:00	0.00
IF-EX-CB106	OUTFALL	0.00	0.00	0.00	0 00:00	0.00
IF-EX-CB110	OUTFALL	0.00	0.00	0.00	0 00:00	0.00
IF-EX-CB113	OUTFALL	0.00	0.00	0.00	0 00:00	0.00
IF-EX-CB116	OUTFALL	0.00	0.00	0.00	0 00:00	0.00
IF-EX-CB117	OUTFALL	0.00	0.00	0.00	0 00:00	0.00
IF-EX-CB121	OUTFALL	0.00	0.00	0.00	0 00:00	0.00
IF-EX-CB123/124	OUTFALL	0.00	0.00	0.00	0 00:00	0.00
IF-EX-CB128	OUTFALL	0.00	0.00	0.00	0 00:00	0.00
IF-EX-CB137	OUTFALL	0.00	0.00	0.00	0 00:00	0.00
IF-EX-CB28	OUTFALL	0.00	0.00	0.00	0 00:00	0.00
IF-EX-CB30	OUTFALL	0.00	0.00	0.00	0 00:00	0.00
IF-EX-CB38	OUTFALL	0.00	0.00	0.00	0 00:00	0.00
IF-EX-CB40	OUTFALL	0.00	0.00	0.00	0 00:00	0.00
IF-EX-CB50	OUTFALL	0.00	0.00	0.00	0 00:00	0.00
IF-EX-CB52	OUTFALL	0.00	0.00	0.00	0 00:00	0.00
IF-EX-CB54	OUTFALL	0.00	0.00	0.00	0 00:00	0.00
IF-EX-CB58	OUTFALL	0.00	0.00	0.00	0 00:00	0.00
IF-EX-CB64	OUTFALL	0.00	0.00	0.00	0 00:00	0.00
IF-EX-CB66	OUTFALL	0.00	0.00	0.00	0 00:00	0.00
IF-EX-CB68	OUTFALL	0.00	0.00	0.00	0 00:00	0.00
IF-EX-CB82	OUTFALL	0.00	0.00	0.00	0 00:00	0.00
IF-EX-CB84	OUTFALL	0.00	0.00	0.00	0 00:00	0.00
IF-EX-CB87	OUTFALL	0.00	0.00	0.00	0 00:00	0.00
IF-EX-CB90	OUTFALL	0.00	0.00	0.00	0 00:00	0.00
IF-EX-CB92	OUTFALL	0.00	0.00	0.00	0 00:00	0.00
IF-EX-CB95	OUTFALL	0.00	0.00	0.00	0 00:00	0.00
IF-EX-CB96	OUTFALL	0.00	0.00	0.00	0 00:00	0.00
IF-EX-CBMH117	OUTFALL	0.00	0.00	0.00	0 00:00	0.00
Major01	OUTFALL	0.01	0.32	113.19	0 01:10	0.28
Major02	OUTFALL	0.00	0.08	111.69	0 01:09	0.08
Major03	OUTFALL	0.00	0.00	106.80	0 00:00	0.00

Date: 04/24/20

4837 Albion Road - Hard Rock Ottawa (116111)  
 PCSWMM Model Results - Ex. Conditions (100-year, 3-hour Chicago Storm)

Minor01	OUTFALL	0.11	0.32	103.27	0	01:15	0.32
EX-BLDG01	STORAGE	0.01	0.11	120.11	0	01:16	0.11
EX-CB10	STORAGE	0.28	1.39	112.90	0	01:05	1.39
EX-CB100	STORAGE	0.90	1.21	113.98	0	01:13	1.21
EX-CB102	STORAGE	0.97	1.29	113.98	0	01:14	1.29
EX-CB104	STORAGE	1.22	1.57	113.97	0	03:10	1.57
EX-CB106	STORAGE	1.30	1.65	113.96	0	03:11	1.65
EX-CB110	STORAGE	0.38	1.92	113.92	0	01:11	1.91
EX-CB113	STORAGE	0.38	1.96	113.96	0	01:11	1.92
EX-CB116	STORAGE	0.12	0.96	113.95	0	01:11	0.86
EX-CB117	STORAGE	0.31	1.87	113.96	0	01:11	1.80
EX-CB121	STORAGE	0.28	1.82	113.97	0	01:11	1.71
EX-CB123/124	STORAGE	0.38	2.10	113.90	0	01:10	2.09
EX-CB128	STORAGE	0.81	1.41	113.92	0	02:53	1.41
EX-CB132	STORAGE	0.60	2.95	111.83	0	01:09	2.92
EX-CB134	STORAGE	0.10	1.92	113.52	0	01:08	1.92
EX-CB137	STORAGE	0.15	1.88	113.88	0	01:10	1.82
EX-CB14	STORAGE	0.29	2.05	114.47	0	01:11	2.05
EX-CB28	STORAGE	0.86	1.49	113.92	0	02:44	1.49
EX-CB30	STORAGE	0.82	1.44	113.94	0	01:43	1.44
EX-CB38	STORAGE	0.02	0.38	113.24	0	01:14	0.38
EX-CB40	STORAGE	0.02	0.38	113.30	0	01:14	0.38
EX-CB50	STORAGE	1.28	1.63	113.97	0	03:01	1.63
EX-CB52	STORAGE	1.19	1.53	113.97	0	02:52	1.53
EX-CB54	STORAGE	1.12	1.47	113.99	0	01:13	1.46
EX-CB58	STORAGE	1.20	1.56	114.00	0	05:56	1.56
EX-CB60	STORAGE	1.44	1.81	113.96	0	03:12	1.81
EX-CB62	STORAGE	1.00	1.32	113.96	0	03:11	1.32
EX-CB64	STORAGE	1.48	1.85	113.95	0	03:14	1.85
EX-CB66	STORAGE	1.24	1.58	113.95	0	03:14	1.58
EX-CB68	STORAGE	1.06	1.38	113.95	0	03:14	1.38
EX-CB72	STORAGE	0.12	2.15	113.33	0	01:10	2.01
EX-CB82	STORAGE	0.30	1.71	114.33	0	01:10	1.71
EX-CB84	STORAGE	0.48	2.19	114.31	0	01:09	2.19
EX-CB87	STORAGE	0.81	1.41	113.91	0	03:01	1.41
EX-CB90	STORAGE	0.80	1.40	113.91	0	03:03	1.40
EX-CB92	STORAGE	0.82	1.43	113.92	0	01:50	1.43
EX-CB95	STORAGE	0.85	1.47	113.92	0	02:54	1.47
EX-CB96	STORAGE	1.00	1.70	113.92	0	02:56	1.70
EX-CBMH117	STORAGE	0.35	1.68	112.94	0	01:05	1.67
EX-CBMH117a	STORAGE	0.02	0.06	111.32	0	01:06	0.06
EX-CBMH117b	STORAGE	0.02	0.09	109.56	0	01:09	0.09
EX-CBMH117c	STORAGE	0.03	0.11	109.23	0	01:09	0.11
EX-MH101	STORAGE	0.11	0.32	104.89	0	01:14	0.32
EX-MH101a	STORAGE	0.11	0.33	107.51	0	01:14	0.33
EX-MH101b	STORAGE	0.10	0.29	105.62	0	01:14	0.29

EX-MH102	STORAGE	0.11	0.32	109.70	0	01:14	0.32
EX-MH102A	STORAGE	0.08	0.54	112.96	0	01:12	0.54
EX-MH103	STORAGE	0.01	0.07	110.78	0	01:12	0.07
EX-MH104	STORAGE	0.11	0.31	110.96	0	01:14	0.31
EX-MH104a	STORAGE	0.11	0.32	110.64	0	01:14	0.32
EX-MH104b	STORAGE	0.12	0.33	110.15	0	01:14	0.33
EX-MH105	STORAGE	0.09	0.13	111.41	0	02:58	0.13
EX-MH106	STORAGE	1.05	1.76	113.91	0	02:56	1.76
EX-MH106a	STORAGE	1.42	2.30	113.91	0	02:58	2.30
EX-MH107	STORAGE	0.91	1.57	113.92	0	02:43	1.57
EX-MH107a	STORAGE	1.02	1.71	113.91	0	02:53	1.71
EX-MH108	STORAGE	0.04	0.60	111.92	0	01:15	0.60
EX-MH109	STORAGE	0.13	0.45	111.43	0	01:14	0.45
EX-MH109a	STORAGE	0.13	0.46	111.36	0	01:14	0.46
EX-MH109b	STORAGE	0.14	0.47	111.25	0	01:14	0.47
EX-MH110	STORAGE	1.50	1.87	113.95	0	03:13	1.87
EX-MH110a	STORAGE	0.06	0.07	112.15	0	03:13	0.07
EX-MH111	STORAGE	1.51	1.89	113.96	0	03:12	1.89
EX-MH112	STORAGE	1.42	1.91	114.06	0	05:57	1.91
EX-MH112a	STORAGE	1.49	1.86	113.96	0	03:11	1.86
EX-MH113	STORAGE	0.03	0.20	112.39	0	01:11	0.20
EX-MH113a	STORAGE	0.05	0.25	112.02	0	01:12	0.25
EX-MH113b	STORAGE	0.05	0.26	112.31	0	01:12	0.26
EX-MH113c	STORAGE	0.05	0.25	112.32	0	01:12	0.25
EX-MH114	STORAGE	0.01	0.09	112.60	0	01:14	0.09
EX-MH115	STORAGE	0.05	0.22	105.27	0	01:11	0.22
EX-MH116	STORAGE	0.05	0.22	105.72	0	01:10	0.22
EX-STM43	STORAGE	0.15	1.50	114.00	0	01:11	1.38
EX-STUB	STORAGE	0.05	0.72	112.10	0	01:15	0.72

\*\*\*\*\*  
 Node Inflow Summary  
 \*\*\*\*\*

Node	Type	Maximum Lateral Inflow LPS	Maximum Total Inflow LPS	Time of Max Occurrence days hr:min	Lateral Inflow Volume 10^6 ltr	Total Inflow Volume 10^6 ltr	Flow Balance Error Percent
HP01	JUNCTION	0.00	160.30	0 01:03	0	0.0722	5.251
HP-EX-CB10	JUNCTION	0.00	666.44	0 01:06	0	0.384	0.031
HP-EX-CB100	JUNCTION	0.00	38.29	0 01:13	0	0.0367	-0.017
HP-EX-CB102	JUNCTION	0.00	0.00	0 00:00	0	0	0.000 ltr
HP-EX-CB102a	JUNCTION	0.00	0.00	0 00:00	0	0	0.000 ltr

4837 Albion Road - Hard Rock Ottawa (116111)  
 PCSWMM Model Results - Ex. Conditions (100-year, 3-hour Chicago Storm)

HP-EX-CB104	JUNCTION	0.00	0.00	0	00:00	0	0	0.000	ltr
HP-EX-CB104a	JUNCTION	0.00	0.00	0	00:00	0	0	0.000	ltr
HP-EX-CB106	JUNCTION	0.00	0.00	0	00:00	0	0	0.000	ltr
HP-EX-CB110	JUNCTION	0.00	1044.30	0	01:11	0	0.355	0.830	
HP-EX-CB113	JUNCTION	0.00	571.52	0	01:10	0	0.272	-0.465	
HP-EX-CB116	JUNCTION	0.00	607.80	0	01:09	0	0.209	-0.988	
HP-EX-CB117	JUNCTION	0.00	1003.42	0	01:11	0	0.537	-0.362	
HP-EX-CB123/124	JUNCTION	0.00	998.37	0	01:10	0	0.489	0.062	
HP-EX-CB123/124a	JUNCTION	0.00	1014.86	0	01:10	0	0.49	0.108	
HP-EX-CB128	JUNCTION	0.00	0.00	0	00:00	0	0	0.000	ltr
HP-EX-CB131	JUNCTION	0.00	2812.67	0	01:10	0	1.68	0.091	
HP-EX-CB134	JUNCTION	0.00	29.91	0	01:09	0	0.00686	0.001	
HP-EX-CB137	JUNCTION	0.00	2765.19	0	01:10	0	1.67	0.010	
HP-EX-CB28	JUNCTION	0.00	0.00	0	00:00	0	0	0.000	ltr
HP-EX-CB30	JUNCTION	0.00	0.00	0	00:00	0	0	0.000	ltr
HP-EX-CB38	JUNCTION	0.00	6.19	0	01:09	0	9.98e-06	-1.084	ltr
HP-EX-CB40	JUNCTION	0.00	0.00	0	00:00	0	0	0.000	ltr
HP-EX-CB50	JUNCTION	0.00	0.00	0	00:00	0	0	0.000	ltr
HP-EX-CB50a	JUNCTION	0.00	0.00	0	00:00	0	0	0.000	ltr
HP-EX-CB52	JUNCTION	0.00	0.00	0	00:00	0	0	0.000	ltr
HP-EX-CB52a	JUNCTION	0.00	8.61	0	01:14	0	5.26e-05	0.359	
HP-EX-CB54	JUNCTION	0.00	17.48	0	01:13	0	0.000158	0.120	
HP-EX-CB54a	JUNCTION	0.00	45.80	0	01:13	0	0.0312	0.041	
HP-EX-CB58	JUNCTION	0.00	10.57	0	05:56	0	9.37e-05	0.946	
HP-EX-CB60	JUNCTION	0.00	0.00	0	00:00	0	0	0.000	ltr
HP-EX-CB62	JUNCTION	0.00	36.90	0	07:28	0	0.183	-0.006	
HP-EX-CB64	JUNCTION	0.00	0.00	0	00:00	0	0	0.000	ltr
HP-EX-CB66	JUNCTION	0.00	0.00	0	00:00	0	0	0.000	ltr
HP-EX-CB68	JUNCTION	0.00	0.00	0	00:00	0	0	0.000	ltr
HP-EX-CB72	JUNCTION	0.00	758.59	0	01:09	0	0.0541	-0.301	
HP-EX-CB82	JUNCTION	0.00	1265.81	0	01:10	0	1.31	0.004	
HP-EX-CB84	JUNCTION	0.00	1701.21	0	01:09	0	1.34	0.001	
HP-EX-CB87	JUNCTION	0.00	0.00	0	00:00	0	0	0.000	ltr
HP-EX-CB90	JUNCTION	0.00	0.00	0	00:00	0	0	0.000	ltr
HP-EX-CB92	JUNCTION	0.00	0.00	0	00:00	0	0	0.000	ltr
HP-EX-CB95	JUNCTION	0.00	0.00	0	00:00	0	0	0.000	ltr
HP-EX-CB96	JUNCTION	0.00	0.00	0	00:00	0	0	0.000	ltr
HP-EX-CBMH117	JUNCTION	0.00	194.74	0	01:05	0	0.0855	0.016	
HP-EXMH102Aa	JUNCTION	0.00	1166.48	0	01:11	0	1.31	-0.000	
HP-EX-STM43	JUNCTION	0.00	664.01	0	01:09	0	0.329	-0.748	
IF-EX-CB10	OUTFALL	0.00	0.26	0	00:25	0	0.00403	0.000	
IF-EX-CB100	OUTFALL	0.00	0.14	0	00:24	0	0.00917	0.000	
IF-EX-CB102	OUTFALL	0.00	0.14	0	00:22	0	0.0094	0.000	
IF-EX-CB104	OUTFALL	0.00	0.14	0	00:22	0	0.01	0.000	
IF-EX-CB106	OUTFALL	0.00	0.14	0	00:22	0	0.0101	0.000	
IF-EX-CB110	OUTFALL	0.00	0.14	0	00:21	0	0.00278	0.000	

IF-EX-CB113	OUTFALL	0.00	0.14	0	00:21	0	0.00264	0.000	
IF-EX-CB116	OUTFALL	0.00	0.14	0	00:25	0	0.00177	0.000	
IF-EX-CB117	OUTFALL	0.00	0.14	0	00:25	0	0.00199	0.000	
IF-EX-CB121	OUTFALL	0.00	0.14	0	00:25	0	0.00186	0.000	
IF-EX-CB123/124	OUTFALL	0.00	0.28	0	00:25	0	0.00488	0.000	
IF-EX-CB128	OUTFALL	0.00	0.14	0	00:22	0	0.0066	0.000	
IF-EX-CB137	OUTFALL	0.00	0.21	0	00:25	0	0.00239	0.000	
IF-EX-CB28	OUTFALL	0.00	0.14	0	00:24	0	0.00667	0.000	
IF-EX-CB30	OUTFALL	0.00	0.14	0	00:23	0	0.00661	0.000	
IF-EX-CB38	OUTFALL	0.00	0.14	0	00:25	0	0.00147	0.000	
IF-EX-CB40	OUTFALL	0.00	0.14	0	00:25	0	0.00147	0.000	
IF-EX-CB50	OUTFALL	0.00	0.14	0	00:22	0	0.0101	0.000	
IF-EX-CB52	OUTFALL	0.00	0.14	0	00:22	0	0.00998	0.000	
IF-EX-CB54	OUTFALL	0.00	0.14	0	00:23	0	0.00978	0.000	
IF-EX-CB58	OUTFALL	0.00	0.14	0	00:22	0	0.00995	0.000	
IF-EX-CB64	OUTFALL	0.00	0.14	0	00:22	0	0.0105	0.000	
IF-EX-CB66	OUTFALL	0.00	0.14	0	00:22	0	0.0101	0.000	
IF-EX-CB68	OUTFALL	0.00	0.14	0	00:22	0	0.00969	0.000	
IF-EX-CB82	OUTFALL	0.00	0.21	0	00:25	0	0.00303	0.000	
IF-EX-CB84	OUTFALL	0.00	0.21	0	00:25	0	0.00367	0.000	
IF-EX-CB87	OUTFALL	0.00	0.14	0	00:24	0	0.0066	0.000	
IF-EX-CB90	OUTFALL	0.00	0.14	0	00:25	0	0.00658	0.000	
IF-EX-CB92	OUTFALL	0.00	0.14	0	00:24	0	0.00661	0.000	
IF-EX-CB95	OUTFALL	0.00	0.14	0	00:22	0	0.00666	0.000	
IF-EX-CB96	OUTFALL	0.00	0.14	0	00:25	0	0.0066	0.000	
IF-EX-CBMH117	OUTFALL	0.00	0.26	0	00:25	0	0.00417	0.000	
Major01	OUTFALL	0.00	2647.43	0	01:10	0	1.64	0.000	
Major02	OUTFALL	0.00	951.89	0	01:09	0	0.655	0.000	
Major03	OUTFALL	0.00	0.00	0	00:00	0	0	0.000	ltr
Minor01	OUTFALL	0.00	590.70	0	01:15	0	6.02	0.000	
EX-BLDG01	STORAGE	413.51	413.51	0	01:10	0.624	0.624	-0.009	
EX-CB10	STORAGE	223.17	477.33	0	01:05	0.317	0.479	-0.068	
EX-CB100	STORAGE	29.76	60.25	0	00:57	0.0421	0.0779	0.008	
EX-CB102	STORAGE	89.28	118.05	0	01:09	0.127	0.197	0.106	
EX-CB104	STORAGE	109.12	132.30	0	01:10	0.155	0.344	-0.064	
EX-CB106	STORAGE	84.32	91.24	0	01:06	0.119	0.519	0.014	
EX-CB110	STORAGE	104.16	1348.66	0	01:11	0.147	0.637	-0.035	
EX-CB113	STORAGE	148.80	411.65	0	01:11	0.211	0.29	0.319	
EX-CB116	STORAGE	44.64	561.57	0	01:09	0.0633	0.16	0.525	
EX-CB117	STORAGE	19.84	775.53	0	01:11	0.0281	0.334	0.646	
EX-CB121	STORAGE	39.68	1178.62	0	01:11	0.0562	0.472	-0.350	
EX-CB123/124	STORAGE	346.59	1057.21	0	01:10	0.495	0.821	-0.025	
EX-CB128	STORAGE	49.60	49.60	0	01:05	0.0702	0.0725	-0.005	
EX-CB132	STORAGE	319.62	988.63	0	01:09	0.411	0.818	0.003	
EX-CB134	STORAGE	49.60	49.60	0	01:10	0.0705	0.0705	-0.002	
EX-CB137	STORAGE	44.64	1122.71	0	01:10	0.0633	0.562	-0.220	



4837 Albion Road - Hard Rock Ottawa (116111)  
 PCSWMM Model Results - Ex. Conditions (100-year, 3-hour Chicago Storm)

EX-CB14	STORAGE	1483.97	1483.97	0	01:10	2.26	2.33	-0.158
EX-CB28	STORAGE	114.08	119.53	0	01:10	0.162	0.18	0.081
EX-CB30	STORAGE	162.64	162.64	0	01:10	0.203	0.204	0.056
EX-CB38	STORAGE	14.88	15.14	0	01:09	0.0211	0.0211	-0.037
EX-CB40	STORAGE	14.88	14.88	0	01:05	0.0211	0.0211	-0.037
EX-CB50	STORAGE	124.00	124.78	0	01:10	0.176	0.787	-0.015
EX-CB52	STORAGE	99.20	139.96	0	01:05	0.14	0.286	-0.023
EX-CB54	STORAGE	39.68	68.06	0	01:13	0.0561	0.0933	-0.042
EX-CB58	STORAGE	94.24	608.13	0	05:56	0.134	1.15	0.669
EX-CB60	STORAGE	34.72	70.83	0	01:05	0.0491	0.254	0.007
EX-CB62	STORAGE	54.56	54.56	0	01:05	0.0772	0.147	0.010
EX-CB64	STORAGE	54.56	59.89	0	01:10	0.0772	0.323	0.010
EX-CB66	STORAGE	94.24	113.54	0	01:05	0.134	0.241	-0.039
EX-CB68	STORAGE	69.44	69.44	0	01:10	0.0983	0.104	0.081
EX-CB72	STORAGE	19.47	556.25	0	01:09	0.0283	0.06	-0.121
EX-CB82	STORAGE	133.90	1284.88	0	01:10	0.19	1.5	-0.041
EX-CB84	STORAGE	114.07	697.04	0	01:04	0.162	0.299	-0.111
EX-CB87	STORAGE	119.84	119.84	0	01:10	0.15	0.15	0.005
EX-CB90	STORAGE	69.44	69.44	0	01:10	0.0985	0.101	0.003
EX-CB92	STORAGE	124.12	124.12	0	01:10	0.155	0.155	-0.014
EX-CB95	STORAGE	49.60	67.27	0	01:05	0.0702	0.14	0.015
EX-CB96	STORAGE	89.28	141.61	0	01:07	0.127	0.291	-0.022
EX-CBMH117	STORAGE	208.30	212.17	0	01:05	0.296	0.388	-0.021
EX-CBMH117a	STORAGE	0.00	18.60	0	01:05	0	0.221	0.000
EX-CBMH117b	STORAGE	0.00	38.55	0	01:08	0	0.285	-0.000
EX-CBMH117c	STORAGE	0.00	60.45	0	01:09	0	0.464	0.004
EX-MH101	STORAGE	0.00	590.69	0	01:14	0	6.02	0.002
EX-MH101a	STORAGE	0.00	530.82	0	01:14	0	5.56	-0.000
EX-MH101b	STORAGE	0.00	530.85	0	01:14	0	5.56	-0.009
EX-MH102	STORAGE	0.00	530.79	0	01:14	0	5.56	-0.000
EX-MH102A	STORAGE	0.00	115.35	0	01:10	0	0.947	0.001
EX-MH103	STORAGE	0.00	13.05	0	01:10	0	0.0427	-0.003
EX-MH104	STORAGE	0.00	366.40	0	01:14	0	4.11	0.000
EX-MH104a	STORAGE	0.00	385.28	0	01:14	0	4.37	0.000
EX-MH104b	STORAGE	0.00	404.03	0	01:14	0	4.57	-0.000
EX-MH105	STORAGE	0.00	21.97	0	02:58	0	0.982	-0.000
EX-MH106	STORAGE	0.00	61.25	0	00:58	0	0.753	-0.024
EX-MH106a	STORAGE	0.00	57.73	0	00:59	0	0.988	-0.000
EX-MH107	STORAGE	0.00	55.00	0	01:00	0	0.37	-0.081
EX-MH107a	STORAGE	0.00	87.58	0	00:58	0	0.784	0.031
EX-MH108	STORAGE	0.00	178.63	0	01:16	0	0.624	-0.010
EX-MH109	STORAGE	0.00	308.23	0	01:13	0	2.84	0.002
EX-MH109a	STORAGE	0.00	327.15	0	01:14	0	3.04	-0.000
EX-MH109b	STORAGE	0.00	345.03	0	01:14	0	3.13	0.000
EX-MH110	STORAGE	0.00	41.57	0	05:34	0	1.33	0.001
EX-MH110a	STORAGE	0.00	19.59	0	03:13	0	1.28	-0.000

EX-MH111	STORAGE	0.00	64.08	0	01:27	0	1.21	-0.001
EX-MH112	STORAGE	0.00	587.87	0	05:56	0	2.11	-0.608
EX-MH112a	STORAGE	0.00	141.38	0	05:34	0	1.36	0.320
EX-MH113	STORAGE	0.00	61.33	0	01:11	0	0.348	-0.012
EX-MH113a	STORAGE	0.00	111.12	0	01:12	0	0.935	-0.000
EX-MH113b	STORAGE	0.00	84.56	0	01:12	0	0.667	0.001
EX-MH113c	STORAGE	0.00	71.80	0	01:11	0	0.507	0.011
EX-MH114	STORAGE	0.00	12.19	0	01:14	0	0.0392	-0.042
EX-MH115	STORAGE	0.00	60.27	0	01:10	0	0.464	0.084
EX-MH116	STORAGE	0.00	60.31	0	01:09	0	0.464	-0.009
EX-STM43	STORAGE	306.07	537.33	0	01:11	0.593	0.632	0.359
EX-STUB	STORAGE	0.00	178.60	0	01:11	0	0.624	0.010

\*\*\*\*\*  
 Node Surcharge Summary  
 \*\*\*\*\*

No nodes were surcharged.

\*\*\*\*\*  
 Node Flooding Summary  
 \*\*\*\*\*

No nodes were flooded.

\*\*\*\*\*  
 Storage Volume Summary  
 \*\*\*\*\*

Storage Unit	Average Volume 1000 m3	Avg Pcnt Full	Evap Pcnt Loss	Exfil Pcnt Loss	Maximum Volume 1000 m3	Max Pcnt Full	Time of Max Occurrence days hr:min	Maximum Outflow LPS
EX-BLDG01	0.007	0	0	0	0.166	4	0 01:16	178.60
EX-CB10	0.010	18	0	0	0.054	100	0 01:02	666.70
EX-CB100	0.006	81	0	0	0.007	100	0 00:58	49.69
EX-CB102	0.048	66	0	0	0.073	100	0 01:12	62.61
EX-CB104	0.077	28	0	0	0.161	58	0 03:10	38.86
EX-CB106	0.043	35	0	0	0.093	76	0 03:11	78.16
EX-CB110	0.015	18	0	0	0.082	100	0 01:09	862.15
EX-CB113	0.013	18	0	0	0.077	100	0 01:09	459.57
EX-CB116	0.007	14	0	0	0.046	100	0 01:08	481.95

4837 Albion Road - Hard Rock Ottawa (116111)  
 PCSWMM Model Results - Ex. Conditions (100-year, 3-hour Chicago Storm)

EX-CB117	0.006	14	0	0	0.040	100	0	01:08	701.73
EX-CB121	0.007	14	0	0	0.048	100	0	01:08	1176.79
EX-CB123/124	0.011	16	0	0	0.065	100	0	01:07	1018.16
EX-CB128	0.013	28	0	0	0.032	70	0	02:53	21.25
EX-CB132	0.001	18	0	0	0.003	86	0	01:09	973.78
EX-CB134	0.000	2	0	0	0.008	100	0	01:08	49.94
EX-CB137	0.001	9	0	0	0.017	100	0	01:05	1433.51
EX-CB14	0.001	19	0	0	0.007	100	0	00:44	1365.42
EX-CB28	0.054	22	0	0	0.144	59	0	02:44	34.03
EX-CB30	0.040	22	0	0	0.121	67	0	01:43	26.06
EX-CB38	0.000	0	0	0	0.006	9	0	01:14	6.24
EX-CB40	0.000	0	0	0	0.006	9	0	01:14	6.23
EX-CB50	0.054	31	0	0	0.119	67	0	03:01	191.27
EX-CB52	0.069	43	0	0	0.145	90	0	02:52	44.48
EX-CB54	0.006	84	0	0	0.007	100	0	00:55	58.00
EX-CB58	0.055	42	0	0	0.129	99	0	05:56	269.35
EX-CB60	0.015	38	0	0	0.036	93	0	03:12	42.39
EX-CB62	0.012	35	0	0	0.031	92	0	03:11	39.46
EX-CB64	0.033	34	0	0	0.073	75	0	03:14	41.71
EX-CB66	0.067	28	0	0	0.137	57	0	03:14	22.07
EX-CB68	0.034	31	0	0	0.075	66	0	03:14	16.51
EX-CB72	0.000	4	0	0	0.010	100	0	01:09	378.86
EX-CB82	0.013	15	0	0	0.089	100	0	01:04	1284.91
EX-CB84	0.029	17	0	0	0.168	100	0	01:08	548.06
EX-CB87	0.037	27	0	0	0.097	72	0	03:01	22.61
EX-CB90	0.018	17	0	0	0.058	56	0	03:03	24.13
EX-CB92	0.036	29	0	0	0.094	77	0	01:50	22.35
EX-CB95	0.015	30	0	0	0.038	73	0	02:54	36.12
EX-CB96	0.069	31	0	0	0.176	78	0	02:56	37.46
EX-CBMH117	0.004	9	0	0	0.050	100	0	01:05	216.40
EX-CBMH117a	0.000	1	0	0	0.000	4	0	01:06	18.52
EX-CBMH117b	0.000	0	0	0	0.000	2	0	01:09	38.54
EX-CBMH117c	0.000	1	0	0	0.000	3	0	01:09	60.31
EX-MH101	0.000	5	0	0	0.000	14	0	01:14	590.70
EX-MH101a	0.000	2	0	0	0.000	7	0	01:14	530.85
EX-MH101b	0.000	2	0	0	0.000	6	0	01:14	530.85
EX-MH102	0.000	2	0	0	0.000	7	0	01:14	530.82
EX-MH102A	0.000	5	0	0	0.001	31	0	01:12	114.80
EX-MH103	0.000	0	0	0	0.000	3	0	01:12	12.54
EX-MH104	0.000	3	0	0	0.000	9	0	01:14	366.41
EX-MH104a	0.000	3	0	0	0.000	9	0	01:14	385.30
EX-MH104b	0.000	3	0	0	0.000	8	0	01:14	404.03
EX-MH105	0.000	3	0	0	0.000	5	0	02:58	21.97
EX-MH106	0.001	57	0	0	0.002	96	0	02:56	46.53
EX-MH106a	0.001	42	0	0	0.002	68	0	02:58	33.59
EX-MH107	0.001	35	0	0	0.002	60	0	02:43	37.44

EX-MH107a	0.001	57	0	0	0.002	96	0	02:53	61.25
EX-MH108	0.000	2	0	0	0.001	26	0	01:15	178.68
EX-MH109	0.000	5	0	0	0.000	17	0	01:14	308.15
EX-MH109a	0.000	5	0	0	0.000	17	0	01:14	327.04
EX-MH109b	0.000	5	0	0	0.000	16	0	01:14	344.73
EX-MH110	0.001	53	0	0	0.002	66	0	03:13	42.11
EX-MH110a	0.000	4	0	0	0.000	4	0	03:13	19.59
EX-MH111	0.002	72	0	0	0.002	89	0	03:12	65.17
EX-MH112	0.001	51	0	0	0.002	69	0	05:57	608.13
EX-MH112a	0.001	74	0	0	0.002	92	0	03:11	149.21
EX-MH113	0.000	2	0	0	0.000	14	0	01:11	58.66
EX-MH113a	0.000	2	0	0	0.000	9	0	01:12	110.96
EX-MH113b	0.000	3	0	0	0.000	17	0	01:12	84.12
EX-MH113c	0.000	3	0	0	0.000	16	0	01:12	71.31
EX-MH114	0.000	1	0	0	0.000	8	0	01:14	12.18
EX-MH115	0.000	3	0	0	0.000	12	0	01:11	60.24
EX-MH116	0.000	2	0	0	0.000	9	0	01:10	60.27
EX-STM43	0.006	12	0	0	0.051	100	0	01:05	660.22
EX-STUB	0.000	2	0	0	0.001	32	0	01:15	178.63

\*\*\*\*\*  
 Outfall Loading Summary  
 \*\*\*\*\*

Outfall Node	Flow Freq Pcnt	Avg Flow LPS	Max Flow LPS	Total Volume 10^6 ltr
IF-EX-CB10	29.65	0.25	0.26	0.004
IF-EX-CB100	86.18	0.14	0.14	0.009
IF-EX-CB102	87.56	0.14	0.14	0.009
IF-EX-CB104	91.45	0.14	0.14	0.010
IF-EX-CB106	92.08	0.14	0.14	0.010
IF-EX-CB110	34.16	0.14	0.14	0.003
IF-EX-CB113	32.75	0.14	0.14	0.003
IF-EX-CB116	24.07	0.14	0.14	0.002
IF-EX-CB117	26.40	0.14	0.14	0.002
IF-EX-CB121	25.11	0.14	0.14	0.002
IF-EX-CB123/124	34.33	0.25	0.28	0.005
IF-EX-CB128	67.73	0.14	0.14	0.007
IF-EX-CB137	22.92	0.20	0.21	0.002
IF-EX-CB28	68.41	0.14	0.14	0.007
IF-EX-CB30	67.86	0.14	0.14	0.007
IF-EX-CB38	20.45	0.14	0.14	0.001

4837 Albion Road - Hard Rock Ottawa (116111)  
 PCSWMM Model Results - Ex. Conditions (100-year, 3-hour Chicago Storm)

IF-EX-CB40	20.45	0.14	0.14	0.001
IF-EX-CB50	92.15	0.14	0.14	0.010
IF-EX-CB52	91.24	0.14	0.14	0.010
IF-EX-CB54	90.10	0.14	0.14	0.010
IF-EX-CB58	91.04	0.14	0.14	0.010
IF-EX-CB64	93.92	0.14	0.14	0.011
IF-EX-CB66	91.72	0.14	0.14	0.010
IF-EX-CB68	89.36	0.14	0.14	0.010
IF-EX-CB82	27.81	0.20	0.21	0.003
IF-EX-CB84	31.37	0.21	0.21	0.004
IF-EX-CB87	67.79	0.14	0.14	0.007
IF-EX-CB90	67.68	0.14	0.14	0.007
IF-EX-CB92	67.89	0.14	0.14	0.007
IF-EX-CB95	68.24	0.14	0.14	0.007
IF-EX-CB96	69.53	0.14	0.14	0.007
IF-EX-CBMH117	30.08	0.25	0.26	0.004
Major01	8.45	424.77	2647.43	1.639
Major02	96.77	14.53	951.89	0.655
Major03	0.00	0.00	0.00	0.000
Minor01	99.24	106.90	590.70	6.021
-----				
System	58.50	551.18	2647.43	8.513

\*\*\*\*\*  
 Link Flow Summary  
 \*\*\*\*\*

Link	Type	Maximum  Flow  LPS	Time of Max Occurrence days hr:min	Maximum  Veloc  m/sec	Max/ Full Flow	Max/ Full Depth
C1	CONDUIT	951.89	0 01:09	1.06	0.02	0.30
C10	CONDUIT	666.44	0 01:06	1.79	0.02	0.16
C100	CONDUIT	537.15	0 01:09	1.10	0.01	0.46
C11	CONDUIT	667.57	0 01:06	0.82	0.01	0.28
C12	CONDUIT	0.00	0 00:00	0.00	0.00	0.00
C13	CONDUIT	29.91	0 01:09	0.12	0.00	0.08
C136	CONDUIT	537.33	0 01:09	1.57	0.02	0.30
C14	CONDUIT	0.00	0 00:00	0.00	0.00	0.14
C15	CONDUIT	194.74	0 01:05	0.58	0.01	0.12
C16	CONDUIT	254.10	0 01:05	0.60	0.01	0.16
C17	CONDUIT	1265.81	0 01:10	1.25	0.03	0.34
C18	CONDUIT	0.00	0 00:00	0.00	0.00	0.12
C19	CONDUIT	0.00	0 00:00	0.00	0.00	0.05

C2	CONDUIT	29.91	0 01:09	0.04	0.00	0.26
C20	CONDUIT	611.94	0 01:11	1.87	0.03	0.41
C21	CONDUIT	608.13	0 05:56	1.18	0.02	0.19
C22	CONDUIT	2647.43	0 01:10	2.75	0.19	0.33
C24	CONDUIT	0.00	0 00:00	0.00	0.00	0.12
C25	CONDUIT	0.00	0 00:00	0.00	0.00	0.14
C26	CONDUIT	0.00	0 00:00	0.00	0.00	0.14
C27	CONDUIT	0.00	0 00:00	0.00	0.00	0.15
C28	CONDUIT	0.00	0 00:00	0.00	0.00	0.12
C29	CONDUIT	0.00	0 00:00	0.00	0.00	0.15
C3	CONDUIT	1265.81	0 01:10	3.36	0.08	0.17
C3_1	CONDUIT	0.00	0 00:00	0.00	0.00	0.10
C3_2	CONDUIT	0.00	0 00:00	0.00	0.00	0.11
C30	CONDUIT	0.00	0 00:00	0.00	0.00	0.05
C31	CONDUIT	0.00	0 00:00	0.00	0.00	0.15
C32	CONDUIT	0.00	0 00:00	0.00	0.00	0.15
C33	CONDUIT	0.00	0 00:00	0.00	0.00	0.12
C34	CONDUIT	0.00	0 00:00	0.00	0.00	0.12
C35	CONDUIT	0.00	0 00:00	0.00	0.00	0.10
C36	CONDUIT	36.90	0 07:28	0.19	0.00	0.17
C37	CONDUIT	37.65	0 07:28	0.14	0.00	0.18
C38	CONDUIT	0.00	0 00:00	0.00	0.00	0.14
C39	CONDUIT	0.00	0 00:00	0.00	0.00	0.13
C4	CONDUIT	0.00	0 00:00	0.00	0.00	0.00
C4_1	CONDUIT	1014.86	0 01:10	1.96	0.12	0.21
C4_2	CONDUIT	1079.04	0 01:10	1.91	0.03	0.31
C40	CONDUIT	17.48	0 01:13	0.07	0.00	0.08
C41	CONDUIT	12.00	0 01:13	0.04	0.00	0.13
C42	CONDUIT	0.00	0 00:00	0.00	0.00	0.13
C43	CONDUIT	0.00	0 00:00	0.00	0.00	0.13
C44	CONDUIT	48.81	0 01:13	0.20	0.00	0.09
C45	CONDUIT	45.80	0 01:13	0.11	0.00	0.15
C46	CONDUIT	3.57	0 01:14	0.01	0.00	0.13
C47	CONDUIT	8.61	0 01:14	0.02	0.00	0.18
C48	CONDUIT	0.00	0 00:00	0.00	0.00	0.13
C49	CONDUIT	0.00	0 00:00	0.00	0.00	0.15
C5	CONDUIT	1415.50	0 01:10	2.28	0.04	0.29
C50	CONDUIT	10.57	0 05:56	0.03	0.00	0.14
C51	CONDUIT	7.71	0 05:56	0.02	0.00	0.13
C52	CONDUIT	0.00	0 00:00	0.00	0.00	0.13
C53	CONDUIT	0.00	0 00:00	0.00	0.00	0.11
C54	CONDUIT	0.00	0 00:00	0.00	0.00	0.15
C55	CONDUIT	0.00	0 00:00	0.00	0.00	0.14
C56	CONDUIT	0.00	0 00:00	0.00	0.00	0.18
C57	CONDUIT	0.00	0 00:00	0.00	0.00	0.11
C58	CONDUIT	40.58	0 01:13	0.08	0.00	0.18

4837 Albion Road - Hard Rock Ottawa (116111)  
 PCSWMM Model Results - Ex. Conditions (100-year, 3-hour Chicago Storm)

C59	CONDUIT	38.29	0	01:13	0.07	0.00	0.22
C6	CONDUIT	1985.74	0	01:09	5.40	0.04	0.13
C60	CONDUIT	0.00	0	00:00	0.00	0.00	0.18
C61	CONDUIT	0.00	0	00:00	0.00	0.00	0.15
C62	CONDUIT	0.00	0	00:00	0.00	0.00	0.15
C63	CONDUIT	0.00	0	00:00	0.00	0.00	0.13
C64	CONDUIT	0.00	0	00:00	0.00	0.00	0.11
C65	CONDUIT	0.00	0	00:00	0.00	0.00	0.14
C66	CONDUIT	0.00	0	00:00	0.00	0.00	0.14
C67	CONDUIT	0.00	0	00:00	0.00	0.00	0.11
C68	CONDUIT	0.00	0	00:00	0.00	0.00	0.11
C69	CONDUIT	0.00	0	00:00	0.00	0.00	0.28
C7	CONDUIT	587.36	0	01:04	2.15	0.01	0.38
C70	CONDUIT	508.17	0	01:09	0.78	0.02	0.44
C71	CONDUIT	480.68	0	01:11	0.62	0.02	0.42
C72	CONDUIT	0.00	0	00:00	0.00	0.00	0.11
C73	CONDUIT	0.00	0	00:00	0.00	0.00	0.20
C76	CONDUIT	1003.42	0	01:11	1.25	0.04	0.46
C77	CONDUIT	409.08	0	01:12	0.86	0.02	0.44
C79	CONDUIT	748.42	0	01:10	0.68	0.02	0.46
C8	CONDUIT	2812.67	0	01:10	3.99	0.04	0.23
C81	CONDUIT	998.37	0	01:10	0.87	0.02	0.38
C82	CONDUIT	0.00	0	00:00	0.00	0.00	0.00
C83	CONDUIT	0.27	0	01:10	0.00	0.00	0.00
C84_1	CONDUIT	6.19	0	01:09	0.01	0.00	0.20
C84_2	CONDUIT	721.18	0	01:10	0.71	0.02	0.53
C85	CONDUIT	832.17	0	01:09	0.80	0.02	0.50
C86	CONDUIT	849.04	0	01:11	0.49	0.04	0.62
C87	CONDUIT	446.38	0	01:11	0.30	0.03	0.66
C88	CONDUIT	1127.98	0	01:11	1.16	0.03	0.35
C89	CONDUIT	1166.46	0	01:11	2.06	0.04	0.33
C9	CONDUIT	1166.48	0	01:11	0.99	0.03	0.59
EXCBMH117a-117b	CONDUIT	18.52	0	01:06	1.97	0.13	0.30
EXCBMH117b-117c	CONDUIT	38.54	0	01:09	2.09	0.27	0.40
EX-Ditch	CONDUIT	160.30	0	01:03	0.20	0.05	0.74
EXMH101-OUT	CONDUIT	590.70	0	01:15	3.31	0.37	0.42
EXMH102-101a	CONDUIT	530.82	0	01:14	2.94	0.38	0.43
EXMH102a-102	CONDUIT	114.80	0	01:12	1.67	1.26	0.93
EXMH103-102	CONDUIT	12.54	0	01:12	0.96	0.12	0.24
EXMH104-104a	CONDUIT	366.41	0	01:14	2.46	0.52	0.52
EXMH104a-104b	CONDUIT	385.30	0	01:14	2.50	0.55	0.54
EXMH104b-102	CONDUIT	404.03	0	01:14	2.57	0.58	0.54
EXMH105-104	CONDUIT	21.97	0	02:58	0.68	0.19	0.26
EXMH108-109	CONDUIT	178.68	0	01:16	1.62	0.97	1.00
EXMH109-109a	CONDUIT	308.15	0	01:14	1.34	0.87	0.76
EXMH109a-109b	CONDUIT	327.04	0	01:14	1.38	0.92	0.78

EXMH109b-104	CONDUIT	344.73	0	01:14	1.59	0.97	0.71
EXMH110-109	CONDUIT	19.59	0	03:14	1.48	0.13	0.38
EXMH111-110	CONDUIT	25.37	0	01:12	0.36	1.30	1.00
EXMH112-112a	CONDUIT	149.21	0	05:34	3.01	5.16	1.00
EXMH112a-111	CONDUIT	65.17	0	05:34	0.92	2.24	1.00
EXMH113-113c	CONDUIT	58.66	0	01:11	0.86	0.56	0.60
EXMH113a-109	CONDUIT	110.96	0	01:12	1.43	1.04	0.66
EXMH113b-113a	CONDUIT	84.12	0	01:12	1.06	0.81	0.68
EXMH113c-113b	CONDUIT	71.31	0	01:12	0.92	0.68	0.67
EXMH114-113	CONDUIT	12.18	0	01:14	0.42	0.30	0.57
EXMH115-101	CONDUIT	60.24	0	01:11	0.97	0.88	0.86
EXMH116-115	CONDUIT	60.27	0	01:10	1.09	0.89	0.73
EXMH117c-116	CONDUIT	60.31	0	01:09	2.81	0.42	0.45
EXSTUB-108	CONDUIT	178.63	0	01:16	1.62	1.56	1.00
X-CB-103 (X-CB)	CONDUIT	53.48	0	00:57	1.09	1.32	1.00
X-CB-105 (X-CB)	CONDUIT	38.72	0	00:58	0.79	1.01	1.00
X-CB-107 (X-CB)	CONDUIT	27.19	0	00:57	0.55	0.87	1.00
X-CB-109 (X-CB)	CONDUIT	78.02	0	01:27	1.59	1.35	1.00
X-CB-118 (X-CB)	CONDUIT	34.08	0	01:02	1.20	0.38	1.00
X-CB-129 (X-CB)	CONDUIT	24.07	0	00:57	0.77	0.88	1.00
X-CB-89 (X-CB)	CONDUIT	22.47	0	01:00	0.98	0.35	1.00
X-CB-91 (X-CB)	CONDUIT	23.99	0	01:02	0.99	0.32	1.00
X-CB-94 (X-CB)	CONDUIT	22.21	0	01:00	0.71	0.58	1.00
X-CB-97 (X-CB)	CONDUIT	35.98	0	01:01	0.60	0.44	1.00
X-CB-98 (X-CB)	CONDUIT	37.32	0	00:58	0.53	1.08	1.00
X-STM-11 (X-STM)	CONDUIT	26.67	0	01:10	0.54	0.58	1.00
X-STM-13 (1) (X-STM)	CONDUIT	530.85	0	01:14	2.82	0.40	0.44
X-STM-13 (X-STM)	CONDUIT	530.85	0	01:14	3.30	0.32	0.39
X-STM-25 (X-STM) 1	CONDUIT	46.53	0	00:58	0.32	0.13	1.00
X-STM-27 (X-STM) 1	CONDUIT	37.44	0	00:58	0.53	0.71	1.00
X-STM-27 (X-STM) 2	CONDUIT	61.25	0	00:58	0.87	1.55	1.00
X-STM-29 (X-STM)	CONDUIT	33.89	0	01:00	0.48	1.35	1.00
X-STM-31 (X-STM)	CONDUIT	25.92	0	01:00	0.83	1.16	1.00
X-STM-51 (X-STM)	CONDUIT	188.64	0	01:27	2.67	6.48	1.00
X-STM-53 (X-STM)	CONDUIT	30.54	0	00:56	0.43	0.74	1.00
X-STM-55 (X-STM)	CONDUIT	44.34	0	00:55	0.90	0.95	1.00
X-STM-59 (X-STM)	CONDUIT	91.11	0	05:56	2.90	2.77	1.00
X-STM-61 (X-STM)	CONDUIT	42.39	0	01:27	0.86	1.05	1.00
X-STM-63 (X-STM)	CONDUIT	16.08	0	01:04	0.63	0.66	1.00
X-STM-65 (X-STM)	CONDUIT	41.57	0	05:34	0.85	1.64	1.00
X-STM-67 (X-STM)	CONDUIT	20.96	0	00:56	0.45	0.41	1.00
X-STM-69 (X-STM)	CONDUIT	21.93	0	00:55	0.49	0.61	1.00
OR1	ORIFICE	49.67	0	01:11			1.00
OR2	ORIFICE	115.35	0	01:10			1.00
OR3	ORIFICE	18.60	0	01:05			1.00
OR4	ORIFICE	19.59	0	03:13			1.00

Date: 04/24/20

4837 Albion Road - Hard Rock Ottawa (116111)  
 PCSWMM Model Results - Ex. Conditions (100-year, 3-hour Chicago Storm)

X-CB-112 (X-CB)	ORIFICE	13.15	0	01:11	1.00
X-CB-115 (X-CB)	ORIFICE	13.39	0	01:10	1.00
X-CB-120 (X-CB)	ORIFICE	14.08	0	01:11	1.00
X-CB-122 (X-CB)	ORIFICE	13.88	0	01:11	1.00
X-CB-127 (X-CB)	ORIFICE	19.52	0	01:10	1.00
X-CB-131 (X-CB)	ORIFICE	21.91	0	01:09	1.00
X-CB-133 (X-CB)	ORIFICE	20.03	0	01:08	1.00
X-CB-135 (X-CB)	ORIFICE	18.39	0	01:10	1.00
X-CB-83 (X-CB)	ORIFICE	18.89	0	01:10	1.00
X-CB-86 (X-CB)	ORIFICE	19.89	0	01:09	1.00
X-STM-25 (X-STM)_2	ORIFICE	21.97	0	02:58	1.00
X-STM-39 (X-STM)	ORIFICE	6.10	0	01:14	1.00
X-STM-41 (X-STM)	ORIFICE	6.09	0	01:14	1.00
X-STM-73 (X-STM)	ORIFICE	13.05	0	01:10	1.00
EX-BLDG01-OUT	DUMMY	178.60	0	01:11	
INFIL-EX-CB10	DUMMY	0.26	0	00:25	
INFIL-EX-CB100	DUMMY	0.14	0	00:24	
INFIL-EX-CB102	DUMMY	0.14	0	00:22	
INFIL-EX-CB104	DUMMY	0.14	0	00:22	
INFIL-EX-CB106	DUMMY	0.14	0	00:22	
INFIL-EX-CB110	DUMMY	0.14	0	00:21	
INFIL-EX-CB113	DUMMY	0.14	0	00:21	
INFIL-EX-CB116	DUMMY	0.14	0	00:25	
INFIL-EX-CB117	DUMMY	0.14	0	00:25	
INFIL-EX-CB121	DUMMY	0.14	0	00:25	
INFIL-EX-CB123/124	DUMMY	0.28	0	00:25	
INFIL-EX-CB128	DUMMY	0.14	0	00:22	
INFIL-EX-CB137	DUMMY	0.21	0	00:25	
INFIL-EX-CB28	DUMMY	0.14	0	00:24	
INFIL-EX-CB30	DUMMY	0.14	0	00:23	
INFIL-EX-CB38	DUMMY	0.14	0	00:25	
INFIL-EX-CB40	DUMMY	0.14	0	00:25	
INFIL-EX-CB50	DUMMY	0.14	0	00:22	
INFIL-EX-CB52	DUMMY	0.14	0	00:22	
INFIL-EX-CB54	DUMMY	0.14	0	00:23	
INFIL-EX-CB58	DUMMY	0.14	0	00:22	
INFIL-EX-CB64	DUMMY	0.14	0	00:22	
INFIL-EX-CB66	DUMMY	0.14	0	00:22	
INFIL-EX-CB68	DUMMY	0.14	0	00:22	
INFIL-EX-CB82	DUMMY	0.21	0	00:25	
INFIL-EX-CB84	DUMMY	0.21	0	00:25	
INFIL-EX-CB87	DUMMY	0.14	0	00:24	
INFIL-EX-CB90	DUMMY	0.14	0	00:25	
INFIL-EX-CB92	DUMMY	0.14	0	00:24	
INFIL-EX-CB95	DUMMY	0.14	0	00:22	
INFIL-EX-CB96	DUMMY	0.14	0	00:25	

INFIL-EX-CBMH117 DUMMY 0.26 0 00:25

\*\*\*\*\*  
 Flow Classification Summary  
 \*\*\*\*\*

Conduit	Adjusted /Actual Length	Dry		Fraction of Time in Flow Class			Down Crit	Norm Ltd	Inlet Ctrl	
		Dry	Up Dry	Down Dry	Sub Crit	Sup Crit				
C1	1.00	0.03	0.00	0.00	0.11	0.00	0.00	0.85	0.01	0.00
C10	1.00	0.78	0.10	0.00	0.12	0.00	0.00	0.00	0.89	0.00
C100	1.00	0.94	0.02	0.00	0.03	0.00	0.00	0.00	0.94	0.00
C11	1.00	0.87	0.01	0.00	0.11	0.00	0.00	0.01	0.06	0.00
C12	1.00	1.00	0.00	0.00	0.00	0.00	0.00	0.00	0.00	0.00
C13	1.00	0.96	0.03	0.00	0.01	0.00	0.00	0.00	0.95	0.00
C136	1.00	0.89	0.08	0.00	0.03	0.00	0.00	0.00	0.94	0.00
C14	1.00	0.42	0.58	0.00	0.00	0.00	0.00	0.00	0.00	0.00
C15	1.00	0.84	0.13	0.00	0.03	0.00	0.00	0.00	0.94	0.00
C16	1.00	0.78	0.18	0.00	0.03	0.00	0.00	0.00	0.95	0.00
C17	1.00	0.80	0.12	0.00	0.09	0.00	0.00	0.00	0.91	0.00
C18	1.00	0.43	0.57	0.00	0.00	0.00	0.00	0.00	0.00	0.00
C19	1.00	0.55	0.45	0.00	0.00	0.00	0.00	0.00	0.00	0.00
C2	1.00	0.88	0.11	0.00	0.01	0.00	0.00	0.00	0.95	0.00
C20	1.00	0.90	0.02	0.00	0.08	0.00	0.00	0.00	0.00	0.00
C21	1.00	0.23	0.26	0.00	0.31	0.00	0.19	0.00	0.00	0.00
C22	1.00	0.89	0.00	0.00	0.05	0.06	0.00	0.00	0.01	0.00
C24	1.00	0.43	0.57	0.00	0.00	0.00	0.00	0.00	0.00	0.00
C25	1.00	0.42	0.58	0.00	0.00	0.00	0.00	0.00	0.00	0.00
C26	1.00	0.42	0.58	0.00	0.00	0.00	0.00	0.00	0.00	0.00
C27	1.00	0.42	0.58	0.00	0.00	0.00	0.00	0.00	0.00	0.00
C28	1.00	0.42	0.58	0.00	0.00	0.00	0.00	0.00	0.00	0.00
C29	1.00	0.42	0.58	0.00	0.00	0.00	0.00	0.00	0.00	0.00
C3	1.00	0.91	0.00	0.00	0.00	0.08	0.00	0.00	0.03	0.00
C3_1	1.00	0.44	0.56	0.00	0.00	0.00	0.00	0.00	0.00	0.00
C3_2	1.00	0.92	0.08	0.00	0.00	0.00	0.00	0.00	0.00	0.00
C30	1.00	0.55	0.45	0.00	0.00	0.00	0.00	0.00	0.00	0.00
C31	1.00	0.42	0.58	0.00	0.00	0.00	0.00	0.00	0.00	0.00
C32	1.00	0.42	0.58	0.00	0.00	0.00	0.00	0.00	0.00	0.00
C33	1.00	0.42	0.58	0.00	0.00	0.00	0.00	0.00	0.00	0.00
C34	1.00	0.42	0.58	0.00	0.00	0.00	0.00	0.00	0.00	0.00
C35	1.00	0.44	0.56	0.00	0.00	0.00	0.00	0.00	0.00	0.00
C36	1.00	0.26	0.09	0.00	0.65	0.00	0.00	0.00	0.43	0.00
C37	1.00	0.24	0.11	0.00	0.65	0.00	0.00	0.00	0.43	0.00

4837 Albion Road - Hard Rock Ottawa (116111)  
 PCSWMM Model Results - Ex. Conditions (100-year, 3-hour Chicago Storm)

C38	1.00	0.23	0.77	0.00	0.00	0.00	0.00	0.00	0.00	0.00
C39	1.00	0.23	0.77	0.00	0.00	0.00	0.00	0.00	0.00	0.00
C4	1.00	1.00	0.00	0.00	0.00	0.00	0.00	0.00	0.00	0.00
C4_1	1.00	0.92	0.00	0.00	0.03	0.05	0.00	0.00	0.92	0.00
C4_2	1.00	0.92	0.00	0.00	0.08	0.00	0.00	0.00	0.93	0.00
C40	1.00	0.35	0.64	0.00	0.00	0.00	0.00	0.00	0.95	0.00
C41	1.00	0.23	0.77	0.00	0.00	0.00	0.00	0.00	0.95	0.00
C42	1.00	0.23	0.77	0.00	0.00	0.00	0.00	0.00	0.00	0.00
C43	1.00	0.23	0.77	0.00	0.00	0.00	0.00	0.00	0.00	0.00
C44	1.00	0.35	0.41	0.00	0.24	0.00	0.00	0.00	0.80	0.00
C45	1.00	0.22	0.54	0.00	0.24	0.00	0.00	0.00	0.81	0.00
C46	1.00	0.23	0.77	0.00	0.00	0.00	0.00	0.00	0.95	0.00
C47	1.00	0.21	0.78	0.00	0.00	0.00	0.00	0.00	0.95	0.00
C48	1.00	0.23	0.77	0.00	0.00	0.00	0.00	0.00	0.00	0.00
C49	1.00	0.22	0.78	0.00	0.00	0.00	0.00	0.00	0.00	0.00
C5	1.00	0.91	0.00	0.00	0.08	0.00	0.00	0.00	0.01	0.00
C50	1.00	0.23	0.76	0.00	0.00	0.00	0.00	0.00	0.75	0.00
C51	1.00	0.23	0.77	0.00	0.00	0.00	0.00	0.00	0.75	0.00
C52	1.00	0.23	0.77	0.00	0.00	0.00	0.00	0.00	0.00	0.00
C53	1.00	0.24	0.76	0.00	0.00	0.00	0.00	0.00	0.00	0.00
C54	1.00	0.22	0.78	0.00	0.00	0.00	0.00	0.00	0.00	0.00
C55	1.00	0.22	0.78	0.00	0.00	0.00	0.00	0.00	0.00	0.00
C56	1.00	0.21	0.79	0.00	0.00	0.00	0.00	0.00	0.00	0.00
C57	1.00	0.23	0.77	0.00	0.00	0.00	0.00	0.00	0.00	0.00
C58	1.00	0.22	0.34	0.00	0.44	0.00	0.00	0.00	0.63	0.00
C59	1.00	0.21	0.35	0.00	0.44	0.00	0.00	0.00	0.63	0.00
C6	1.00	0.91	0.00	0.00	0.00	0.08	0.00	0.00	0.93	0.00
C60	1.00	0.21	0.79	0.00	0.00	0.00	0.00	0.00	0.00	0.00
C61	1.00	0.22	0.78	0.00	0.00	0.00	0.00	0.00	0.00	0.00
C62	1.00	0.22	0.78	0.00	0.00	0.00	0.00	0.00	0.00	0.00
C63	1.00	0.23	0.77	0.00	0.00	0.00	0.00	0.00	0.00	0.00
C64	1.00	0.23	0.77	0.00	0.00	0.00	0.00	0.00	0.00	0.00
C65	1.00	0.22	0.78	0.00	0.00	0.00	0.00	0.00	0.00	0.00
C66	1.00	0.22	0.78	0.00	0.00	0.00	0.00	0.00	0.00	0.00
C67	1.00	0.24	0.76	0.00	0.00	0.00	0.00	0.00	0.00	0.00
C68	1.00	0.24	0.76	0.00	0.00	0.00	0.00	0.00	0.00	0.00
C69	1.00	0.81	0.19	0.00	0.00	0.00	0.00	0.00	0.00	0.00
C7	1.00	0.74	0.17	0.00	0.08	0.00	0.00	0.00	0.92	0.00
C70	1.00	0.81	0.02	0.00	0.17	0.00	0.00	0.00	0.87	0.00
C71	1.00	0.81	0.02	0.00	0.17	0.00	0.00	0.00	0.87	0.00
C72	1.00	0.24	0.76	0.00	0.00	0.00	0.00	0.00	0.00	0.00
C73	1.00	0.82	0.18	0.00	0.00	0.00	0.00	0.00	0.00	0.00
C76	1.00	0.81	0.01	0.00	0.18	0.00	0.00	0.00	0.86	0.00
C77	1.00	0.81	0.01	0.00	0.17	0.00	0.00	0.01	0.86	0.00
C79	1.00	0.80	0.02	0.00	0.18	0.00	0.00	0.00	0.86	0.00
C8	1.00	0.89	0.03	0.00	0.01	0.08	0.00	0.00	0.95	0.00

C81	1.00	0.80	0.12	0.00	0.08	0.00	0.00	0.00	0.92	0.00
C82	1.00	1.00	0.00	0.00	0.00	0.00	0.00	0.00	0.00	0.00
C83	1.00	1.00	0.00	0.00	0.00	0.00	0.00	0.00	0.00	0.00
C84_1	1.00	0.90	0.10	0.00	0.00	0.00	0.00	0.00	0.95	0.00
C84_2	1.00	0.76	0.15	0.00	0.10	0.00	0.00	0.00	0.91	0.00
C85	1.00	0.76	0.18	0.00	0.07	0.00	0.00	0.00	0.92	0.00
C86	1.00	0.76	0.00	0.00	0.24	0.00	0.00	0.00	0.82	0.00
C87	1.00	0.76	0.00	0.00	0.24	0.00	0.00	0.00	0.00	0.00
C88	1.00	0.81	0.12	0.00	0.07	0.00	0.00	0.00	0.93	0.00
C89	1.00	0.80	0.12	0.00	0.08	0.00	0.00	0.00	0.95	0.00
C9	1.00	0.84	0.07	0.00	0.09	0.00	0.00	0.00	0.91	0.00
EXCBMH117a-117b	1.00	0.23	0.48	0.00	0.01	0.28	0.00	0.00	0.97	0.00
EXCBMH117b-117c	1.00	0.01	0.22	0.00	0.50	0.28	0.00	0.00	0.98	0.00
EX-Ditch	1.00	0.03	0.01	0.00	0.15	0.00	0.00	0.82	0.02	0.00
EXMH101-OUT	1.00	0.01	0.00	0.00	0.00	0.99	0.00	0.00	0.63	0.00
EXMH102-101a	1.00	0.01	0.00	0.00	0.00	0.00	0.00	0.99	0.00	0.00
EXMH102a-102	1.00	0.01	0.00	0.00	0.00	0.00	0.00	0.99	0.00	0.00
EXMH103-102	1.00	0.01	0.00	0.00	0.00	0.00	0.00	0.99	0.00	0.00
EXMH104-104a	1.00	0.01	0.00	0.00	0.05	0.95	0.00	0.00	0.53	0.00
EXMH104a-104b	1.00	0.01	0.00	0.00	0.05	0.95	0.00	0.00	0.95	0.00
EXMH104b-102	1.00	0.01	0.00	0.00	0.00	0.00	0.00	0.99	0.00	0.00
EXMH105-104	1.00	0.01	0.00	0.00	0.00	0.00	0.00	0.99	0.00	0.00
EXMH108-109	1.00	0.00	0.00	0.00	0.99	0.01	0.00	0.00	0.94	0.00
EXMH109-109a	1.00	0.00	0.00	0.00	1.00	0.00	0.00	0.00	0.28	0.00
EXMH109a-109b	1.00	0.00	0.00	0.00	1.00	0.00	0.00	0.00	0.85	0.00
EXMH109b-104	1.00	0.00	0.00	0.00	0.00	0.00	0.00	1.00	0.00	0.00
EXMH110-109	1.00	0.01	0.00	0.00	0.02	0.02	0.00	0.94	0.03	0.00
EXMH111-110	1.00	0.01	0.00	0.00	0.99	0.00	0.00	0.00	0.00	0.00
EXMH112-112a	1.00	0.01	0.00	0.00	0.98	0.02	0.00	0.00	0.13	0.00
EXMH112a-111	1.00	0.01	0.00	0.00	0.99	0.00	0.00	0.00	0.12	0.00
EXMH113-113c	1.00	0.01	0.00	0.00	0.99	0.00	0.00	0.00	0.26	0.00
EXMH113a-109	1.00	0.01	0.00	0.00	0.00	0.00	0.00	0.99	0.00	0.00
EXMH113b-113a	1.00	0.01	0.53	0.00	0.46	0.00	0.00	0.00	0.93	0.00
EXMH113c-113b	1.00	0.01	0.00	0.00	0.99	0.00	0.00	0.00	0.03	0.00
EXMH114-113	1.00	0.01	0.00	0.00	0.23	0.00	0.00	0.76	0.14	0.00
EXMH115-101	1.00	0.01	0.00	0.00	0.93	0.00	0.00	0.06	0.82	0.00
EXMH116-115	1.00	0.01	0.00	0.00	0.99	0.00	0.00	0.00	0.29	0.00
EXMH117c-116	1.00	0.01	0.00	0.00	0.00	0.00	0.00	0.99	0.00	0.00
EXSTUB-108	1.00	0.00	0.00	0.00	0.83	0.17	0.00	0.00	0.00	0.00
X-CB-103_(X-CB)	1.00	0.13	0.01	0.00	0.86	0.00	0.00	0.00	0.02	0.00
X-CB-105_(X-CB)	1.00	0.09	0.03	0.00	0.86	0.00	0.00	0.01	0.22	0.00
X-CB-107_(X-CB)	1.00	0.08	0.01	0.00	0.91	0.00	0.00	0.00	0.16	0.00
X-CB-109_(X-CB)	1.00	0.08	0.00	0.00	0.91	0.00	0.00	0.01	0.00	0.00
X-CB-118_(X-CB)	1.00	0.74	0.02	0.00	0.22	0.01	0.00	0.01	0.86	0.00
X-CB-129_(X-CB)	1.00	0.32	0.00	0.00	0.66	0.00	0.00	0.01	0.44	0.00
X-CB-89_(X-CB)	1.00	0.30	0.02	0.00	0.67	0.00	0.00	0.00	0.45	0.00

4837 Albion Road - Hard Rock Ottawa (116111)  
 PCSWMM Model Results - Ex. Conditions (100-year, 3-hour Chicago Storm)

X-CB-91_(X-CB)	1.00	0.30	0.02	0.00	0.67	0.00	0.00	0.00	0.45	0.00
X-CB-94_(X-CB)	1.00	0.01	0.31	0.00	0.68	0.00	0.00	0.00	0.45	0.00
X-CB-97_(X-CB)	1.00	0.31	0.01	0.00	0.68	0.00	0.00	0.00	0.44	0.00
X-CB-98_(X-CB)	1.00	0.01	0.30	0.00	0.70	0.00	0.00	0.00	0.42	0.00
X-STM-11_(X-STM)	1.00	0.70	0.01	0.00	0.27	0.00	0.00	0.00	0.03	0.83
X-STM-13_(1)_(X-STM)	1.00	0.01	0.00	0.00	0.00	0.00	0.00	0.99	0.00	0.00
X-STM-13_(X-STM)	1.00	0.01	0.00	0.00	0.00	0.13	0.00	0.87	0.05	0.00
X-STM-25_(X-STM)_1	1.00	0.01	0.00	0.00	0.99	0.00	0.00	0.00	0.13	0.00
X-STM-27_(X-STM)_1	1.00	0.01	0.24	0.00	0.75	0.00	0.00	0.00	0.44	0.00
X-STM-27_(X-STM)_2	1.00	0.01	0.00	0.00	0.68	0.00	0.00	0.31	0.00	0.00
X-STM-29_(X-STM)	1.00	0.32	0.00	0.00	0.67	0.00	0.00	0.02	0.00	0.00
X-STM-31_(X-STM)	1.00	0.32	0.01	0.00	0.66	0.00	0.00	0.01	0.44	0.00
X-STM-51_(X-STM)	1.00	0.08	0.00	0.00	0.89	0.00	0.00	0.03	0.00	0.00
X-STM-53_(X-STM)	1.00	0.08	0.01	0.00	0.91	0.00	0.00	0.00	0.18	0.00
X-STM-55_(X-STM)	1.00	0.09	0.01	0.00	0.90	0.00	0.00	0.00	0.01	0.00
X-STM-59_(X-STM)	1.00	0.08	0.01	0.00	0.88	0.00	0.00	0.03	0.00	0.00
X-STM-61_(X-STM)	1.00	0.01	0.02	0.00	0.97	0.00	0.00	0.00	0.13	0.00
X-STM-63_(X-STM)	1.00	0.01	0.00	0.00	0.87	0.00	0.00	0.12	0.01	0.00
X-STM-65_(X-STM)	1.00	0.01	0.05	0.00	0.94	0.00	0.00	0.00	0.00	0.00
X-STM-67_(X-STM)	1.00	0.06	0.02	0.00	0.92	0.00	0.00	0.00	0.16	0.00
X-STM-69_(X-STM)	1.00	0.09	0.02	0.00	0.89	0.00	0.00	0.01	0.19	0.00

\*\*\*\*\*  
 Conduit Surge Summary  
 \*\*\*\*\*

Conduit	Hours Full			Hours	
	Both Ends	Upstream	Dnstream	Above Normal Flow	Capacity Limited
C9	0.01	0.01	0.12	0.01	0.01
EX-Ditch	0.01	0.01	0.12	0.01	0.01
EXMH102a-102	0.01	1.79	0.01	1.98	0.01
EXMH108-109	0.45	0.45	0.57	0.01	0.42
EXMH111-110	19.68	19.68	19.71	2.17	0.41
EXMH112-112a	19.08	19.08	19.63	1.77	1.34
EXMH112a-111	19.63	19.63	19.68	0.63	0.22
EXMH113a-109	0.01	0.01	0.01	0.23	0.01
EXSTUB-108	0.45	0.49	0.45	0.62	0.45
X-CB-103_(X-CB)	16.94	16.94	17.07	0.01	0.01
X-CB-105_(X-CB)	17.12	17.12	17.99	0.01	0.01
X-CB-107_(X-CB)	18.43	18.43	18.92	0.01	0.01
X-CB-109_(X-CB)	18.92	18.92	19.05	0.43	0.74
X-CB-118_(X-CB)	2.76	2.76	3.12	0.01	0.01

X-CB-129_(X-CB)	12.09	12.09	12.25	0.01	0.01
X-CB-89_(X-CB)	12.11	12.11	13.40	0.01	0.01
X-CB-91_(X-CB)	12.08	12.08	23.43	0.01	0.01
X-CB-94_(X-CB)	12.15	12.15	13.05	0.01	0.01
X-CB-97_(X-CB)	11.94	11.94	12.55	0.01	0.01
X-CB-98_(X-CB)	12.69	12.69	12.74	0.01	0.03
X-STM-11_(X-STM)	3.31	3.31	3.71	0.01	0.01
X-STM-25_(X-STM)_1	12.44	12.44	13.24	0.01	0.01
X-STM-27_(X-STM)_1	12.28	12.28	12.74	0.01	0.01
X-STM-27_(X-STM)_2	12.74	12.74	12.77	0.02	0.03
X-STM-29_(X-STM)	12.02	12.02	12.05	0.02	0.08
X-STM-31_(X-STM)	12.13	12.13	12.45	0.04	0.06
X-STM-51_(X-STM)	18.49	18.49	18.60	2.47	0.82
X-STM-53_(X-STM)	17.88	17.88	18.49	0.01	0.01
X-STM-55_(X-STM)	17.71	17.71	18.19	0.01	0.01
X-STM-59_(X-STM)	18.49	18.49	19.11	0.72	0.74
X-STM-61_(X-STM)	19.62	19.62	19.83	0.08	0.48
X-STM-63_(X-STM)	17.40	17.40	17.56	0.01	0.01
X-STM-65_(X-STM)	19.77	19.77	19.83	0.65	0.77
X-STM-67_(X-STM)	18.59	18.59	23.40	0.01	0.01
X-STM-69_(X-STM)	17.46	17.46	18.47	0.01	0.01

Analysis begun on: Fri Apr 24 11:52:34 2020  
 Analysis ended on: Fri Apr 24 11:52:46 2020  
 Total elapsed time: 00:00:12

Overall Model Schematic

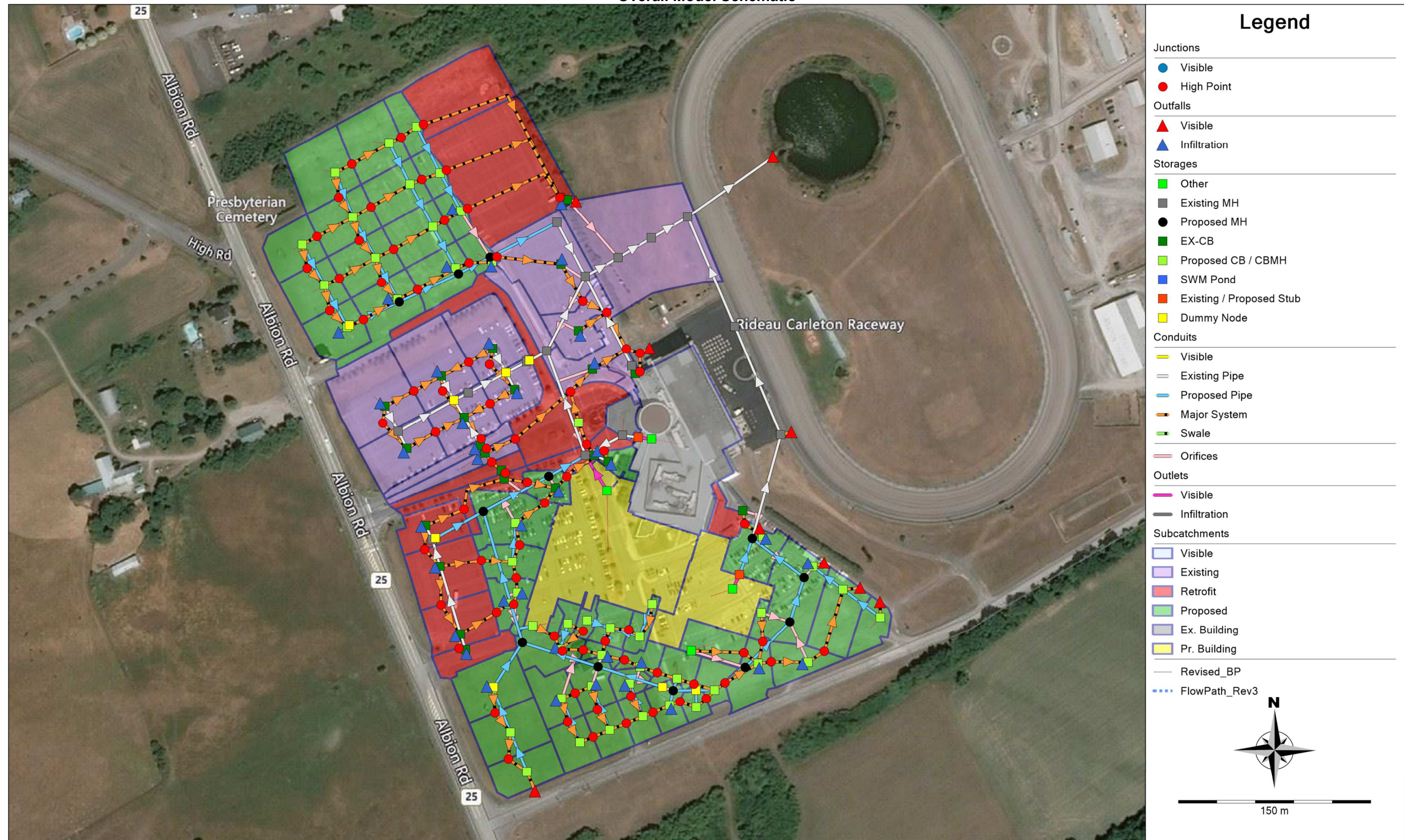



Subcatchments and Flow Paths

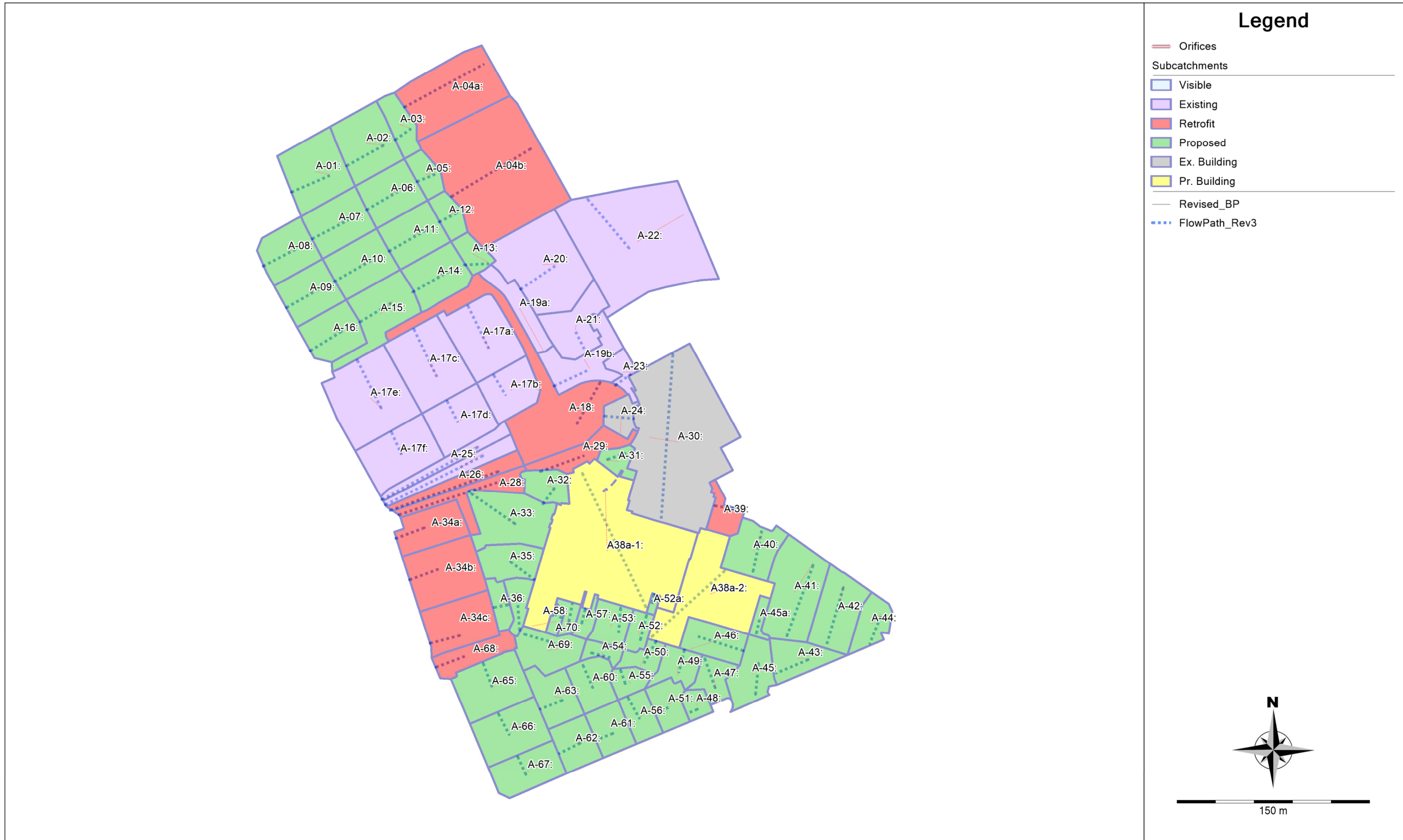

Maintenance Holes

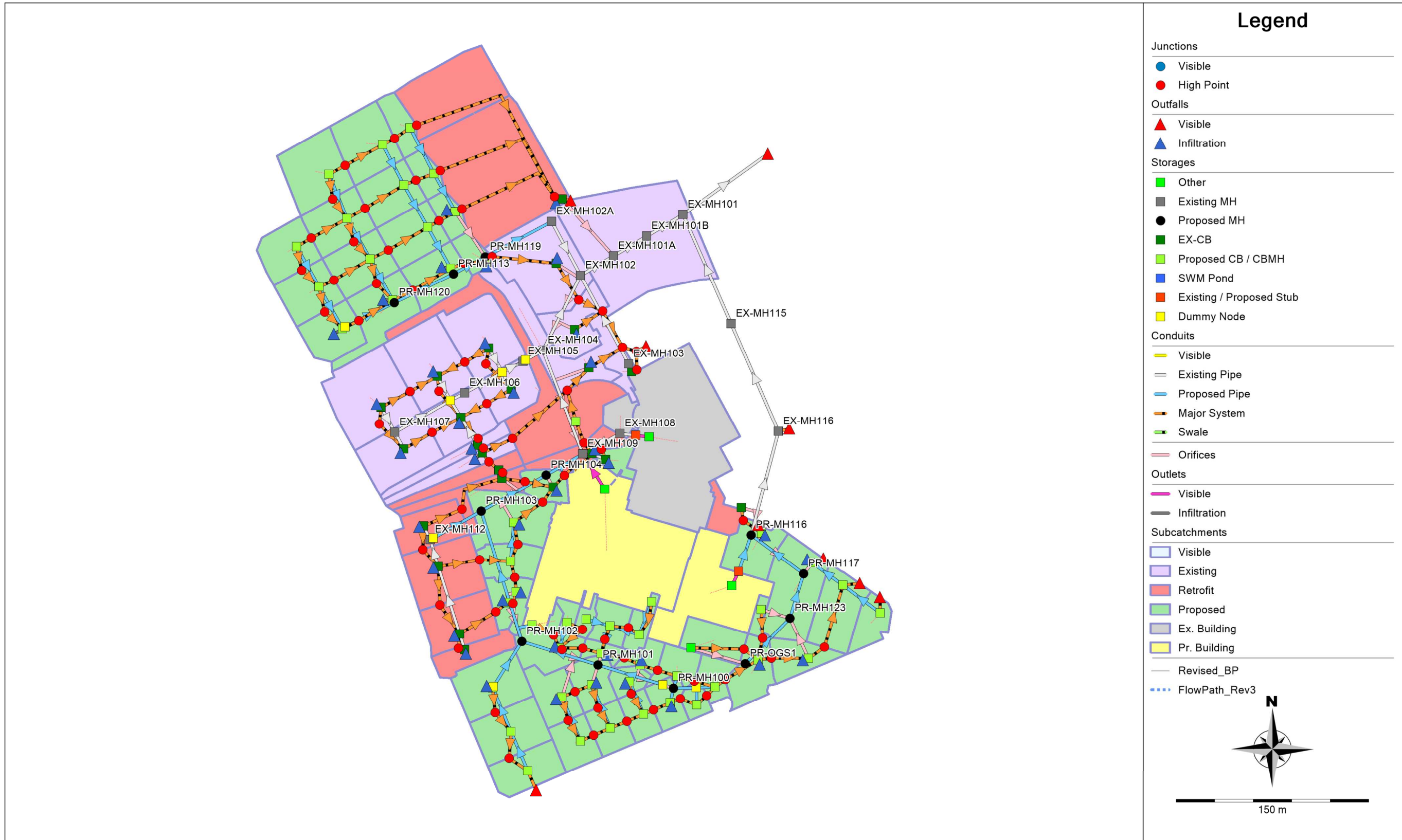

### Legend

- Junctions**
  - Visible: Blue circle
  - High Point: Red circle
- Outfalls**
  - Visible: Red triangle
  - Infiltration: Blue triangle
- Storages**
  - Other: Green square
  - Existing MH: Grey square
  - Proposed MH: Black circle
  - EX-CB: Green square
  - Proposed CB / CBMH: Light green square
  - SWM Pond: Blue square
  - Existing / Proposed Stub: Orange square
  - Dummy Node: Yellow square
- Conduits**
  - Visible: Yellow line
  - Existing Pipe: Grey line
  - Proposed Pipe: Blue line
  - Major System: Orange line with arrows
  - Swale: Green line with arrows
- Orifices**
  - Visible: Pink line
  - Infiltration: Grey line
- Outlets**
  - Visible: Pink line
  - Infiltration: Grey line
- Subcatchments**
  - Visible: Light blue fill
  - Existing: Light purple fill
  - Retrofit: Light red fill
  - Proposed: Light green fill
  - Ex. Building: Grey fill
  - Pr. Building: Yellow fill
- Other**
  - Revised\_BP: Solid grey line
  - FlowPath\_Rev3: Dotted blue line

Catchbasins

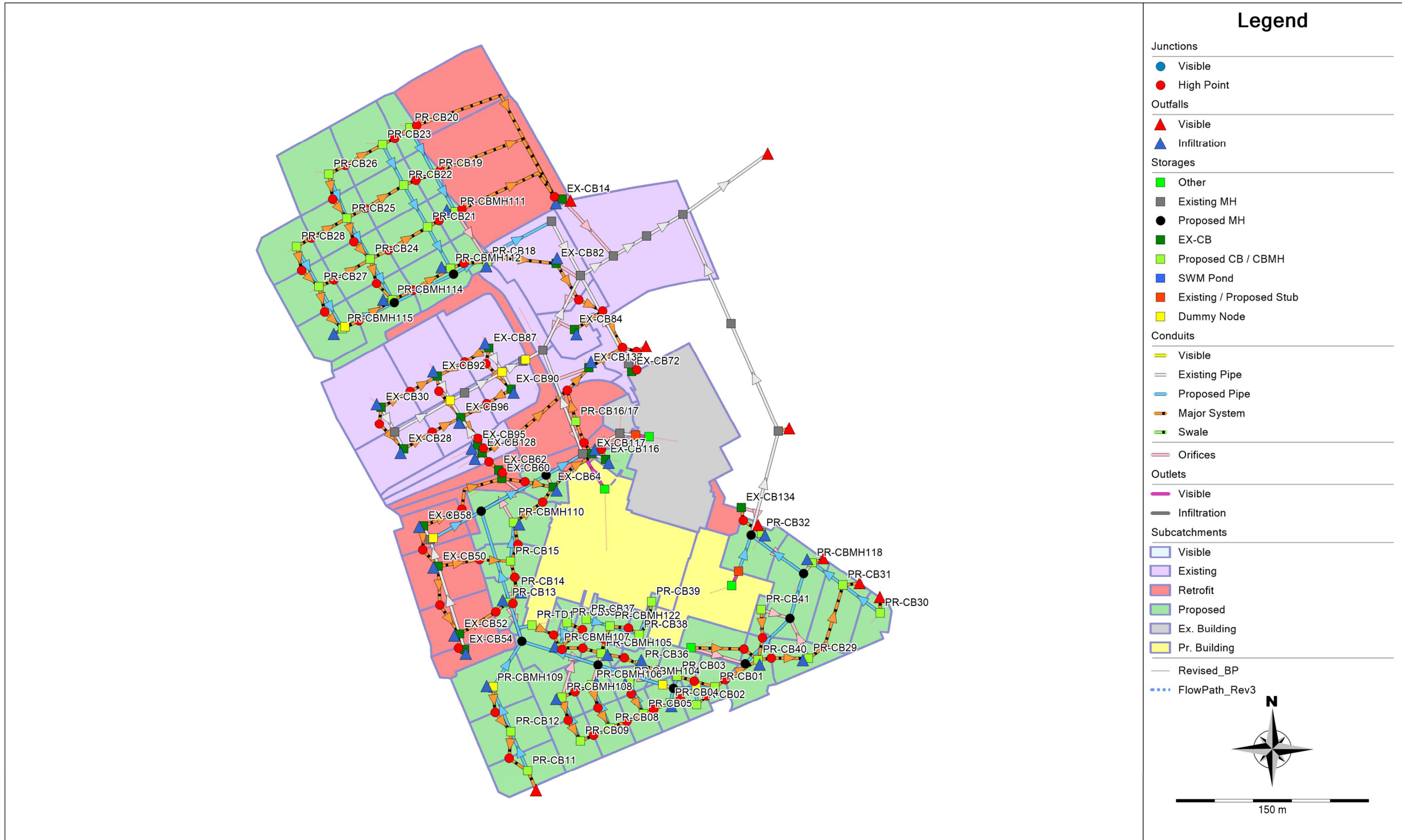

### Legend

**Junctions**

- Visible (Blue circle)
- High Point (Red circle)

**Outfalls**

- Visible (Red triangle)
- Infiltration (Blue triangle)

**Storages**

- Other (Green square)
- Existing MH (Grey square)
- Proposed MH (Black circle)
- EX-CB (Dark green square)
- Proposed CB / CBMH (Light green square)
- SWM Pond (Blue square)
- Existing / Proposed Stub (Orange square)
- Dummy Node (Yellow square)

**Conduits**

- Visible (Yellow line)
- Existing Pipe (Grey line)
- Proposed Pipe (Blue line)
- Major System (Orange line)
- Swale (Green line)

**Orifices**

- Visible (Pink line)

**Outlets**

- Visible (Pink line)
- Infiltration (Grey line)

**Subcatchments**

- Visible (Light blue fill)
- Existing (Light purple fill)
- Retrofit (Light red fill)
- Proposed (Light green fill)
- Ex. Building (Grey fill)
- Pr. Building (Yellow fill)

Revised\_BP (Grey line)

FlowPath\_Rev3 (Dotted blue line)

North Arrow

150 m

4837 Albion Road - Hard Rock Ottawa (116111)  
Subcatchment Parameters - Proposed Conditions

Area ID	Catchment Area (ha)	Runoff Coefficient	Percent Impervious (%)	Zero Impervious (%)	Equivalent Width (m)	Flow Length (m)	Average Slope (%)
A-01	0.235	0.90	100	0	74.6	31.5	1.5
A-02	0.214	0.90	100	0	66.2	32.3	1.5
A-03	0.084	0.90	100	0	58.9	14.3	1.5
A-04a	0.340	0.78	83	0	48.8	69.7	1.5
A-04b	0.759	0.80	86	0	105.2	72.2	1.5
A-05	0.065	0.80	86	0	46.1	14.1	1.5
A-06	0.164	0.90	100	0	47.8	34.3	1.5
A-07	0.177	0.90	100	0	57.6	30.7	1.5
A-08	0.155	0.90	100	0	52.1	29.7	1.5
A-09	0.159	0.90	100	0	53.7	29.6	1.5
A-10	0.177	0.90	100	0	55.0	32.2	1.5
A-11	0.166	0.90	100	0	48.1	34.5	1.5
A-12	0.065	0.80	86	0	42.9	15.2	1.5
A-13	0.058	0.78	83	0	31.7	18.3	1.5
A-14	0.167	0.90	100	0	49.4	33.8	1.5
A-15	0.214	0.90	100	0	71.1	30.1	1.5
A-16	0.155	0.90	100	0	53.1	29.2	1.5
A-17a	0.259	0.62	60	0	68.2	38.0	1.5
A-17b	0.151	0.87	96	0	87.4	17.3	1.5
A-17c	0.293	0.69	70	0	68.8	42.6	1.5
A-17d	0.186	0.89	99	0	105.4	17.7	1.5
A-17e	0.356	0.62	60	0	86.0	41.4	1.5
A-17f	0.227	0.86	94	0	124.9	18.2	1.5
A-18	0.500	0.67	67	0	137.3	36.4	1.5
A-19a	0.103	0.67	67	0	51.5	20.0	1.5
A-19b	0.174	0.67	67	0	69.6	25.0	1.5
A-20	0.397	0.87	96	0	117.5	33.8	1.5
A-21	0.165	0.87	96	0	80.2	20.6	1.5
A-22	0.778	0.20	0	0	155.6	50.0	1.5
A-23	0.050	0.74	77	0	30.2	16.5	1.5
A-24	0.062	0.71	73	100	27.7	22.4	1.5
A-25	0.086	0.65	64	0	10.1	84.9	1.5
A-26	0.102	0.57	53	0	12.0	84.7	1.5
A-27	0.097	0.56	51	0	10.8	89.4	1.5
A-28	0.122	0.80	86	0	14.5	84.4	1.5
A-29	0.110	0.65	64	0	31.1	35.4	1.5
A-30	0.862	0.90	100	100	66.5	129.6	1.5
A-31	0.050	0.90	100	0	24.7	20.3	1.5
A-32	0.081	0.76	80	0	55.2	14.7	1.5
A-33	0.242	0.74	77	0	58.6	41.3	1.5
A-34a	0.152	0.89	99	0	64.8	23.5	1.5
A-34b	0.250	0.90	100	0	108.5	23.0	1.5
A-34c	0.198	0.87	96	0	83.7	23.7	1.5
A-35	0.122	0.82	89	0	53.7	22.7	1.5
A-36	0.052	0.90	100	0	49.1	10.6	1.5
A-37	0.062	0.51	44	0	22.6	27.4	1.5
A38a-1	0.985	0.90	100	100	85.1	115.7	1.5
A38a-2	0.400	0.90	100	100	53.0	75.4	1.5
A-39	0.065	0.90	100	0	43.5	14.9	1.5
A-40	0.152	0.90	100	0	45.2	33.6	1.5
A-41	0.284	0.90	100	0	48.6	58.4	1.5

4837 Albion Road - Hard Rock Ottawa (116111)  
 Subcatchment Parameters - Proposed Conditions



Area ID	Catchment Area (ha)	Runoff Coefficient	Percent Impervious (%)	Zero Impervious (%)	Equivalent Width (m)	Flow Length (m)	Average Slope (%)
A-42	0.197	0.90	100	0	41.4	47.5	1.5
A-43	0.117	0.90	100	0	44.1	26.5	1.5
A-44	0.092	0.90	100	0	41.7	22.1	1.5
A-45	0.140	0.85	93	0	57.4	24.4	1.5
A-45a	0.029	0.90	100	0	19.8	14.6	1.5
A-46	0.122	0.90	100	0	34.1	35.8	1.5
A-47	0.080	0.55	50	0	33.9	23.6	1.5
A-48	0.042	0.81	87	0	48.8	8.6	1.5
A-49	0.085	0.48	40	0	49.0	17.3	1.5
A-50	0.059	0.60	57	0	28.3	20.9	1.5
A-51	0.089	0.89	99	0	69.8	12.7	1.5
A-52	0.052	0.77	81	0	25.8	20.1	1.5
A-52a	0.010	0.90	100	0	15.6	6.4	1.5
A-53	0.092	0.71	73	0	44.4	20.7	1.5
A-54	0.039	0.70	71	0	23.4	16.7	1.5
A-55	0.057	0.76	80	0	49.1	11.6	1.5
A-56	0.083	0.90	100	0	46.1	18.0	1.5
A-57	0.032	0.88	97	25	28.5	11.2	1.5
A-58	0.036	0.68	69	25	26.8	13.4	2
A-60	0.116	0.88	97	0	62.7	18.5	1.5
A-61	0.103	0.90	100	0	79.0	13.0	1.5
A-62	0.113	0.90	100	0	64.0	17.6	1.5
A-63	0.132	0.90	100	0	72.4	18.2	1.5
A-65	0.219	0.90	100	0	103.3	21.2	1.5
A-66	0.199	0.90	100	0	110.8	18.0	1.5
A-67	0.148	0.90	100	0	98.7	15.0	1.5
A-68	0.106	0.64	63	0	42.0	25.2	1.5
<b>Total</b>	<b>14.12</b>	<b>0.79</b>	<b>84</b>	-	-	-	-

4837 Albion Road - Hard Rock Ottawa (116111)  
 Summary of Underground and Surface Storage - Proposed Conditions

CB / CBMH ID	STM ID	Drainage Area (ha)	Elevations (m)			Depths (m)			Provided Storage (m <sup>3</sup> )			StormTech STC-740 Storage Chambers		Infil. Storage Volume (m <sup>3</sup> )	Infil. Bottom Area (m <sup>2</sup> )	Estimated Percolation Rate (mm/hr)	Design Percolation Rate (mm/hr)	Infiltration Rate (L/s)
			Invert	RIM	Ponding	CB	Ponding	Total	UG	Surface <sup>1</sup>	Total	Number	Storage (m <sup>3,2</sup> )					
EX-CB116	A-31	0.050	112.99	113.50	113.60	0.51	0.10	0.61	6.8	9.5	16.3	EX-10	6.8	2.04	17.0	60	30	0.14
EX-CB117	A-29	0.110	112.09	113.35	113.56	1.26	0.21	1.47	6.8	52.1	58.9	EX-10	6.8	2.04	17.0	60	30	0.14
EX-CB128	A-26	0.102	112.51	113.71	113.90	1.20	0.19	1.39	6.8	15.2	22.0	EX-10	6.8	2.04	17.0	60	30	0.14
EX-CB134	A-39	0.065	111.60	113.30	113.40	1.70	0.10	1.80	0.0	2.8	2.8	-	0.0	-	-	110	55	-
EX-CB137	A-19b	0.174	112.00	113.40	113.60	1.40	0.20	1.60	6.8	10.0	16.8	EX-10	6.8	2.04	17.0	90	45	0.21
EX-CB14	A-04a	0.340	111.19	113.40	114.10	2.21	0.70	2.91	6.8	387.7	394.5	EX-10	6.8	2.04	17.0	60	30	0.14
EX-CB28	A-17f	0.227	112.43	113.65	114.00	1.22	0.35	1.57	6.8	1980.3	1987.1	EX-10	6.8	2.04	17.0	60	30	0.14
EX-CB30	A-17e	0.356	112.50	113.70	114.00	1.20	0.30	1.50	6.8	163.5	170.3	EX-10	6.8	2.04	17.0	60	30	0.14
EX-CB50	A-34b	0.250	112.34	113.71	114.00	1.37	0.29	1.66	6.8	164.2	171.0	EX-10	6.8	2.04	17.0	60	30	0.14
EX-CB52	A-34c	0.198	112.44	113.71	113.98	1.27	0.27	1.54	6.8	149.2	156.0	EX-10	6.8	2.04	17.0	60	30	0.14
EX-CB54	A-68	0.106	112.52	113.83	114.00	1.31	0.17	1.48	6.8	35.5	42.3	EX-10	6.8	2.04	17.0	60	30	0.14
EX-CB58	A-34a	0.152	112.44	113.73	114.00	1.29	0.27	1.56	6.8	118.8	125.6	EX-10	6.8	2.04	17.0	60	30	0.14
EX-CB60	A-28	0.122	112.15	113.73	113.90	1.58	0.17	1.75	0.0	39.1	39.1	-	0.0	-	-	60	30	-
EX-CB62	A-27	0.097	112.64	113.76	113.90	1.12	0.14	1.26	0.0	22.2	22.2	-	0.0	-	-	60	30	-
EX-CB64	A-32	0.081	112.10	113.50	113.65	1.40	0.15	1.55	6.8	10.2	17.0	EX-10	6.8	2.04	17.0	60	30	0.14
EX-CB72	A-23	0.050	111.18	112.67	113.00	1.49	0.33	1.82	0.0	10.1	10.1	-	0.0	-	-	90	45	-
EX-CB82	A-20	0.397	112.62	113.84	114.05	1.22	0.21	1.43	6.8	78.7	85.5	EX-10	6.8	2.04	17.0	90	45	0.21
EX-CB84	A-21	0.165	112.12	113.65	114.00	1.53	0.35	1.88	6.8	168.4	175.2	EX-10	6.8	2.04	17.0	90	45	0.21
EX-CB87	A-17a	0.259	112.50	113.68	113.95	1.18	0.27	1.45	6.8	124.3	131.1	EX-10	6.8	2.04	17.0	60	30	0.14
EX-CB90	A-17b	0.151	112.51	113.80	113.95	1.29	0.15	1.44	6.8	85.8	92.6	EX-10	6.8	2.04	17.0	60	30	0.14
EX-CB92	A-17c	0.293	112.49	113.67	113.95	1.18	0.28	1.46	6.8	110.7	117.5	EX-10	6.8	2.04	17.0	60	30	0.14
EX-CB95	A-25	0.086	112.45	113.67	113.95	1.22	0.28	1.50	6.8	22.0	28.8	EX-10	6.8	2.04	17.0	60	30	0.14
EX-CB96	A-17d	0.186	112.22	113.62	113.95	1.40	0.33	1.73	6.8	211.8	218.6	EX-10	6.8	2.04	17.0	60	30	0.14

4837 Albion Road - Hard Rock Ottawa (116111)  
 Summary of Underground and Surface Storage - Proposed Conditions



CB / CBMH ID	STM ID	Drainage Area (ha)	Elevations (m)			Depths (m)			Provided Storage (m <sup>3</sup> )			StormTech STC-740 Storage Chambers		Infil. Storage Volume (m <sup>3</sup> )	Infil. Bottom Area (m <sup>2</sup> )	Estimated Percolation Rate (mm/hr)	Design Percolation Rate (mm/hr)	Infiltration Rate (L/s)	
			Invert	RIM	Ponding	CB	Ponding	Total	UG	Surface <sup>1</sup>	Total	Number	Storage (m <sup>3</sup> ) <sup>2</sup>						
PR-CB01	A-47	0.080	112.40	113.40	113.60	1.00	0.20	1.20	0.0	26.3	26.3	-	0.0	-	-	110	55	-	
PR-CB02	A-48	0.042	112.45	113.40	113.64	0.95	0.24	1.19	0.0	38.5	38.5	-	0.0	-	-	60	30	-	
PR-CB03	A-49	0.085	112.40	113.40	113.64	1.00	0.24	1.24	0.0	26.4	26.4	-	0.0	-	-	60	30	-	
PR-CB04	A-51	0.089	111.80	113.40	113.65	1.60	0.25	1.85	25.4	59.2	84.6	12	25.4	5.68	47.3	60	30	0.39	
PR-CB05	A-56	0.083	112.45	113.45	113.70	1.00	0.25	1.25	0.0	60.4	60.4	-	0.0	-	-	60	30	-	
PR-CB08	A-61	0.103	112.45	113.50	113.75	1.05	0.25	1.30	0.0	65.3	65.3	-	0.0	-	-	60	30	-	
PR-CB09	A-62	0.113	112.45	113.60	113.85	1.15	0.25	1.40	0.0	72.9	72.9	-	0.0	-	-	60	30	-	
PR-CB11	A-67	0.148	112.60	113.60	113.85	1.00	0.25	1.25	0.0	64.0	64.0	-	0.0	-	-	60	30	-	
PR-CB12	A-66	0.199	112.42	113.60	113.87	1.18	0.27	1.45	0.0	107.4	107.4	-	0.0	-	-	60	30	-	
PR-CB13	A-36	0.052	111.90	113.65	113.72	1.75	0.07	1.82	8.4	0.8	9.2	4	8.4	2.19	18.2	60	30	0.15	
PR-CB14	A-37	0.062	111.80	113.55	113.65	1.75	0.10	1.85	8.4	3.7	12.1	4	8.4	2.19	18.2	60	30	0.15	
PR-CB15	A-35	0.122	112.20	113.40	113.67	1.20	0.27	1.47	0.0	56.4	56.4	-	0.0	-	-	60	30	-	
PR-CB16/17	A-18	0.500	112.09	113.35	113.65	1.26	0.30	1.56	0.0	211.9	211.9	-	0.0	-	-	60	30	-	
PR-CB18	A-13	0.058	113.49	115.05	115.20	1.56	0.15	1.71	8.4	4.2	12.6	4	8.4	2.19	18.2	60	30	0.15	
PR-CB19	A-05	0.065	113.65	115.05	115.20	1.40	0.15	1.55	0.0	6.6	6.6	-	0.0	-	-	60	30	-	
PR-CB20	A-03	0.084	113.85	115.05	115.20	1.20	0.15	1.35	0.0	4.5	4.5	-	0.0	-	-	60	30	-	
PR-CB21	A-11	0.166	113.56	115.20	115.40	1.64	0.20	1.84	0.0	37.1	37.1	-	0.0	-	-	60	30	-	
PR-CB22	A-06	0.164	113.80	115.20	115.40	1.40	0.20	1.60	0.0	37.4	37.4	-	0.0	-	-	60	30	-	
PR-CB23	A-02	0.214	114.00	115.20	115.40	1.20	0.20	1.40	0.0	32.0	32.0	-	0.0	-	-	60	30	-	
PR-CB24	A-10	0.177	113.95	115.55	115.85	1.60	0.30	1.90	0.0	121.5	121.5	-	0.0	-	-	60	30	-	
PR-CB25	A-07	0.177	114.14	115.55	115.85	1.41	0.30	1.71	0.0	117.1	117.1	-	0.0	-	-	60	30	-	
PR-CB26	A-01	0.235	114.35	115.55	115.85	1.20	0.30	1.50	0.0	96.0	96.0	-	0.0	-	-	60	30	-	
PR-CB27	A-09	0.159	114.51	115.90	116.20	1.39	0.30	1.69	0.0	120.7	120.7	-	0.0	-	-	60	30	-	
PR-CB28	A-08	0.155	114.70	115.90	116.20	1.20	0.30	1.50	0.0	112.4	112.4	-	0.0	-	-	60	30	-	
PR-CB29	A-43	0.117	111.10	112.70	112.95	1.60	0.25	1.85	63.6	49.8	113.4	30	63.6	13.53	112.7	110	55	1.72	
PR-CB30	A-44	0.092	111.40	112.40	112.65	1.00	0.25	1.25	0.0	39.2	39.2	-	0.0	-	-	110	55	-	
PR-CB31	A-42	0.197	111.20	112.40	112.65	1.20	0.25	1.45	0.0	70.5	70.5	-	0.0	-	-	110	55	-	
PR-CB32	A-40	0.152	110.65	112.90	113.00	2.25	0.10	2.35	59.3	3.0	62.3	28	59.3	12.65	105.5	110	55	1.61	
PR-CB35	A-58	0.036	112.20	113.50	113.75	1.30	0.25	1.55	0.0	6.8	6.8	-	0.0	-	-	60	30	-	
PR-CB36	A-50	0.059	111.85	113.45	113.66	1.60	0.21	1.81	6.3	24.3	30.6	3	6.3	2.19	18.2	60	30	0.15	
PR-CB40	A-45	0.140	111.50	113.00	113.25	1.50	0.25	1.75	12.7	52.0	64.7	6	12.7	3.06	25.5	60	30	0.21	
PR-CBMH104	A-55	0.057	112.04	113.50	113.75	1.46	0.25	1.71	16.9	41.0	57.9	8	16.9	3.93	32.8	60	30	0.27	
PR-CBMH105	A-54	0.039	111.85	113.45	113.70	1.60	0.25	1.85	25.4	22.3	47.7	12	25.4	5.68	47.3	60	30	0.39	
PR-CBMH106	A-60	0.116	112.01	113.50	113.80	1.49	0.30	1.79	33.9	119.8	153.7	16	33.9	7.42	61.8	60	30	0.52	
PR-CBMH107	A-69	0.141	111.84	113.40	113.70	1.56	0.30	1.86	25.4	50.3	75.7	12	25.4	5.68	47.3	60	30	0.39	
PR-CBMH108	A-63	0.132	112.01	113.60	113.85	1.59	0.25	1.84	38.1	72.5	110.6	18	38.1	8.29	69.1	60	30	0.58	
PR-CBMH109	A-65	0.219	111.96	113.60	113.90	1.64	0.30	1.94	106.0	137.4	243.4	50	106.0	22.25	185.4	60	30	1.55	
PR-CBMH110	A-33	0.242	111.62	113.40	113.60	1.78	0.20	1.98	84.8	48.2	133.0	40	84.8	17.89	149.1	60	30	1.24	
PR-CBMH111	A-12	0.065	113.00	115.05	115.20	2.05	0.15	2.20	63.6	7.3	70.9	30	63.6	13.53	112.7	60	30	0.94	
PR-CBMH112	A-14	0.167	113.12	115.20	115.40	2.08	0.20	2.28	148.4	35.5	183.9	70	148.4	31.42	261.8	60	30	2.18	
PR-CBMH114	A-15	0.214	113.51	115.55	115.85	2.04	0.30	2.34	148.4	118.8	267.2	70	148.4	31.42	261.8	60	30	2.18	
PR-CBMH115	A-16	0.155	113.89	115.90	116.20	2.01	0.30	2.31	84.8	110.6	195.4	40	84.8	17.89	149.1	60	30	1.24	
PR-CBMH118	A-41	0.284	110.74	112.40	112.65	1.66	0.25	1.91	95.4	27.8	123.2	45	95.4	20.08	167.3	110	55	2.56	
PR-TD1	A-70	0.018	111.90	112.70	113.75	0.80	1.05	1.85	0.0	121.4	121.4	-	0.0	-	-	-	-	-	
<b>TOTAL</b>		<b>9.991</b>								<b>1192.8</b>	<b>6613.3</b>	<b>7806.1</b>	<b>502</b>	<b>1192.8</b>	<b>229</b>	<b>1909.4</b>			<b>268</b>

<sup>1</sup> Based on Grading Design / Autodesk Civil 3D (refer to drawings 116111-GR & 116111-SWM)

<sup>2</sup> Based on StormTech Site Calculator for STC-740

4837 Albion Road - Hard Rock Ottawa (116111)  
 Summary of Underground and Surface Storage - Proposed Conditions

Storage Provided by StormTech STC-740 Chambers		System Length (m) <sup>1</sup>	
Number	Storage (m <sup>3</sup> ) <sup>1</sup>	1 Row	2 Rows
1	2.1	3.27	3.27
2	4.2	5.44	3.27
3	6.3	7.61	5.44
4	8.4	9.78	5.44
5	10.6	11.95	7.61
6	12.7	14.12	7.61
7	14.8	16.29	9.78
8	16.9	18.46	9.78
9	19.0	20.63	11.95
10	21.2	22.80	11.95
11	23.3	24.97	14.12
12	25.4	27.14	14.12
13	27.5	29.31	16.29
14	29.6	31.48	16.29
15	31.8	33.65	18.46
16	33.9	35.82	18.46
17	36.0	37.99	20.63
18	38.1	40.16	20.63
19	40.2	42.33	22.80
20	42.4	44.50	22.80
21	44.5	46.67	24.97
22	46.6	48.84	24.97
23	48.7	51.01	27.14
24	50.8	53.18	27.14
25	53.0	55.35	29.31
26	55.1	57.52	29.31
27	57.2	59.69	31.48
28	59.3	61.86	31.48
30	63.6	66.20	33.65
32	67.8	70.54	35.82
34	72.0	74.88	37.99
36	76.3	79.22	40.16
38	80.5	83.56	42.33
40	84.8	87.90	44.50
45	95.4	98.55	49.95
50	106.0	109.60	55.35
60	127.2	132.40	67.30
70	148.4	154.10	78.15
EX-10	6.8	-	-

<sup>1</sup> Based on Stormtech site calculator for SC-740 chambers  
 - 150mm stone above chambers  
 - 40% void ratio for surrounding stone  
 - 1 row; Width = 1.90m  
 - 2 rows; Width = 3.35m  
 - Includes end caps



4837 Albion Road - Hard Rock Ottawa (116111)  
 PCSWMM Storage Curves - Proposed Conditions

STM ID	CB ID	Provided Storage	
		Underground	Surface
<b>EX-CB116</b>	<b>A-31</b>	<b>6.8</b>	<b>9.5</b>
Depth (m)	Equivalent Area (m <sup>2</sup> )	Incremental Volume (m <sup>3</sup> )	Total Volume (m <sup>3</sup> )
0.00	0.00	0.0	0.0
0.40	34.00	6.8	6.8
0.41	0.00	0.2	7.0
0.51	0.00	0.0	7.0
0.61	190.00	9.5	16.5
0.62	0.00	1.0	17.4
1.51	0.00	0.0	17.4

EX-10x Infiltration Storage Chambers (6.8 m<sup>3</sup>)  
 0.1m Static Ponding Depth (9.5 m<sup>3</sup>)

STM ID	CB ID	Provided Storage	
		Underground	Surface
<b>EX-CB117</b>	<b>A-29</b>	<b>6.8</b>	<b>52.1</b>
Depth (m)	Equivalent Area (m <sup>2</sup> )	Incremental Volume (m <sup>3</sup> )	Total Volume (m <sup>3</sup> )
0.00	0.00	0.0	0.0
0.40	34.00	6.8	6.8
0.41	0.00	0.2	7.0
1.26	0.00	0.0	7.0
1.47	496.19	52.1	59.1
1.48	0.00	2.5	61.6
2.26	0.00	0.0	61.6

EX-10x Infiltration Storage Chambers (6.8 m<sup>3</sup>)  
 0.21m Static Ponding Depth (52.1 m<sup>3</sup>)

STM ID	CB ID	Provided Storage	
		Underground	Surface
<b>EX-CB128</b>	<b>A-26</b>	<b>6.8</b>	<b>15.2</b>
Depth (m)	Equivalent Area (m <sup>2</sup> )	Incremental Volume (m <sup>3</sup> )	Total Volume (m <sup>3</sup> )
0.00	0.00	0.0	0.0
0.40	34.00	6.8	6.8
0.41	0.00	0.2	7.0
1.20	0.00	0.0	7.0
1.39	160.00	15.2	22.2
1.40	0.00	0.8	23.0
2.20	0.00	0.0	23.0

EX-10x Infiltration Storage Chambers (6.8 m<sup>3</sup>)  
 0.19m Static Ponding Depth (15.2 m<sup>3</sup>)

STM ID	CB ID	Provided Storage	
		Underground	Surface
<b>EX-CB134</b>	<b>A-39</b>	<b>0.0</b>	<b>2.8</b>
Depth (m)	Equivalent Area (m <sup>2</sup> )	Incremental Volume (m <sup>3</sup> )	Total Volume (m <sup>3</sup> )
0.00	0.00	0.0	0.0
0.40	0.00	0.0	0.0
0.41	0.00	0.0	0.0
1.70	0.00	0.0	0.0
1.80	56.00	2.8	2.8
1.81	0.00	0.3	3.1
2.70	0.00	0.0	3.1

-x Infiltration Storage Chambers (0 m<sup>3</sup>)  
 0.1m Static Ponding Depth (2.8 m<sup>3</sup>)

4837 Albion Road - Hard Rock Ottawa (116111)  
PCSWMM Storage Curves - Proposed Conditions

STM ID	CB ID	Provided Storage	
		Underground	Surface
<b>EX-CB137</b>	<b>A-19b</b>	<b>6.8</b>	<b>10.0</b>
Depth (m)	Equivalent Area (m <sup>2</sup> )	Incremental Volume (m <sup>3</sup> )	Total Volume (m <sup>3</sup> )
0.00	0.00	0.0	0.0
0.40	34.00	6.8	6.8
0.41	0.00	0.2	7.0
1.40	0.00	0.0	7.0
1.60	100.00	10.0	17.0
1.61	0.00	0.5	17.5
2.40	0.00	0.0	17.5

EX-10x Infiltration Storage Chambers (6.8 m<sup>3</sup>)  
0.2m Static Ponding Depth (10 m<sup>3</sup>)

STM ID	CB ID	Provided Storage	
		Underground	Surface
<b>EX-CB14</b>	<b>A-04a</b>	<b>6.8</b>	<b>387.7</b>
Depth (m)	Equivalent Area (m <sup>2</sup> )	Incremental Volume (m <sup>3</sup> )	Total Volume (m <sup>3</sup> )
0.00	0.00	0.0	0.0
0.40	34.00	6.8	6.8
0.41	0.00	0.2	7.0
2.21	0.00	0.0	7.0
2.91	1107.71	387.7	394.7
2.92	0.00	5.5	400.2
3.21	0.00	0.0	400.2

EX-10x Infiltration Storage Chambers (6.8 m<sup>3</sup>)  
0.7m Static Ponding Depth (387.7 m<sup>3</sup>)

STM ID	CB ID	Provided Storage	
		Underground	Surface
<b>EX-CB28</b>	<b>A-17f</b>	<b>6.8</b>	<b>1980.3</b>
Depth (m)	Equivalent Area (m <sup>2</sup> )	Incremental Volume (m <sup>3</sup> )	Total Volume (m <sup>3</sup> )
0.00	0.00	0.0	0.0
0.40	34.00	6.8	6.8
0.41	0.00	0.2	7.0
1.22	0.00	0.0	7.0
1.57	11316.00	1980.3	1987.3
1.58	0.00	56.6	2043.9
2.22	0.00	0.0	2043.9

EX-10x Infiltration Storage Chambers (6.8 m<sup>3</sup>)  
0.35m Static Ponding Depth (1980.3 m<sup>3</sup>)

STM ID	CB ID	Provided Storage	
		Underground	Surface
<b>EX-CB30</b>	<b>A-17e</b>	<b>6.8</b>	<b>163.5</b>
Depth (m)	Equivalent Area (m <sup>2</sup> )	Incremental Volume (m <sup>3</sup> )	Total Volume (m <sup>3</sup> )
0.00	0.00	0.0	0.0
0.40	34.00	6.8	6.8
0.41	0.00	0.2	7.0
1.20	0.00	0.0	7.0
1.50	1090.00	163.5	170.5
1.51	0.00	5.5	175.9
2.20	0.00	0.0	175.9

EX-10x Infiltration Storage Chambers (6.8 m<sup>3</sup>)  
0.3m Static Ponding Depth (163.5 m<sup>3</sup>)

4837 Albion Road - Hard Rock Ottawa (116111)  
PCSWMM Storage Curves - Proposed Conditions

STM ID	CB ID	Provided Storage	
		Underground	Surface
<b>EX-CB50</b>	<b>A-34b</b>	<b>6.8</b>	<b>164.2</b>
Depth (m)	Equivalent Area (m <sup>2</sup> )	Incremental Volume (m <sup>3</sup> )	Total Volume (m <sup>3</sup> )
0.00	0.00	0.0	0.0
0.40	34.00	6.8	6.8
0.41	0.00	0.2	7.0
1.37	0.00	0.0	7.0
1.66	1132.41	164.2	171.2
1.67	0.00	5.7	176.8
2.37	0.00	0.0	176.8

EX-10x Infiltration Storage Chambers (6.8 m<sup>3</sup>)  
0.29m Static Ponding Depth (164.2 m<sup>3</sup>)

STM ID	CB ID	Provided Storage	
		Underground	Surface
<b>EX-CB52</b>	<b>A-34c</b>	<b>6.8</b>	<b>149.2</b>
Depth (m)	Equivalent Area (m <sup>2</sup> )	Incremental Volume (m <sup>3</sup> )	Total Volume (m <sup>3</sup> )
0.00	0.00	0.0	0.0
0.40	34.00	6.8	6.8
0.41	0.00	0.2	7.0
1.27	0.00	0.0	7.0
1.54	1105.19	149.2	156.2
1.55	0.00	5.5	161.7
2.27	0.00	0.0	161.7

EX-10x Infiltration Storage Chambers (6.8 m<sup>3</sup>)  
0.27m Static Ponding Depth (149.2 m<sup>3</sup>)

STM ID	CB ID	Provided Storage	
		Underground	Surface
<b>EX-CB54</b>	<b>A-68</b>	<b>6.8</b>	<b>35.5</b>
Depth (m)	Equivalent Area (m <sup>2</sup> )	Incremental Volume (m <sup>3</sup> )	Total Volume (m <sup>3</sup> )
0.00	0.00	0.0	0.0
0.40	34.00	6.8	6.8
0.41	0.00	0.2	7.0
1.31	0.00	0.0	7.0
1.48	417.65	35.5	42.5
1.49	0.00	2.1	44.6
2.31	0.00	0.0	44.6

EX-10x Infiltration Storage Chambers (6.8 m<sup>3</sup>)  
0.17m Static Ponding Depth (35.5 m<sup>3</sup>)

STM ID	CB ID	Provided Storage	
		Underground	Surface
<b>EX-CB58</b>	<b>A-34a</b>	<b>6.8</b>	<b>118.8</b>
Depth (m)	Equivalent Area (m <sup>2</sup> )	Incremental Volume (m <sup>3</sup> )	Total Volume (m <sup>3</sup> )
0.00	0.00	0.0	0.0
0.40	34.00	6.8	6.8
0.41	0.00	0.2	7.0
1.29	0.00	0.0	7.0
1.56	880.00	118.8	125.8
1.57	0.00	4.4	130.2
2.29	0.00	0.0	130.2

EX-10x Infiltration Storage Chambers (6.8 m<sup>3</sup>)  
0.27m Static Ponding Depth (118.8 m<sup>3</sup>)

4837 Albion Road - Hard Rock Ottawa (116111)  
 PCSWMM Storage Curves - Proposed Conditions

STM ID	CB ID	Provided Storage	
		Underground	Surface
<b>EX-CB60</b>	<b>A-28</b>	<b>0.0</b>	<b>39.1</b>
Depth (m)	Equivalent Area (m <sup>2</sup> )	Incremental Volume (m <sup>3</sup> )	Total Volume (m <sup>3</sup> )
0.00	0.00	0.0	0.0
0.40	0.00	0.0	0.0
0.41	0.00	0.0	0.0
1.58	0.00	0.0	0.0
1.75	460.00	39.1	39.1
1.76	0.00	2.3	41.4
2.58	0.00	0.0	41.4

-x Infiltration Storage Chambers (0 m3)  
 0.17m Static Ponding Depth (39.1 m3)

STM ID	CB ID	Provided Storage	
		Underground	Surface
<b>EX-CB62</b>	<b>A-27</b>	<b>0.0</b>	<b>22.2</b>
Depth (m)	Equivalent Area (m <sup>2</sup> )	Incremental Volume (m <sup>3</sup> )	Total Volume (m <sup>3</sup> )
0.00	0.00	0.0	0.0
0.40	0.00	0.0	0.0
0.41	0.00	0.0	0.0
1.12	0.00	0.0	0.0
1.26	317.14	22.2	22.2
1.27	0.00	1.6	23.8
2.12	0.00	0.0	23.8

-x Infiltration Storage Chambers (0 m3)  
 0.14m Static Ponding Depth (22.2 m3)

STM ID	CB ID	Provided Storage	
		Underground	Surface
<b>EX-CB64</b>	<b>A-32</b>	<b>6.8</b>	<b>10.2</b>
Depth (m)	Equivalent Area (m <sup>2</sup> )	Incremental Volume (m <sup>3</sup> )	Total Volume (m <sup>3</sup> )
0.00	0.00	0.0	0.0
0.40	34.00	6.8	6.8
0.41	0.00	0.2	7.0
1.40	0.00	0.0	7.0
1.55	136.00	10.2	17.2
1.56	0.00	0.7	17.9
2.40	0.00	0.0	17.9

EX-10x Infiltration Storage Chambers (6.8 m3)  
 0.15m Static Ponding Depth (10.2 m3)

STM ID	CB ID	Provided Storage	
		Underground	Surface
<b>EX-CB72</b>	<b>A-23</b>	<b>0.0</b>	<b>10.1</b>
Depth (m)	Equivalent Area (m <sup>2</sup> )	Incremental Volume (m <sup>3</sup> )	Total Volume (m <sup>3</sup> )
0.00	0.00	0.0	0.0
0.40	0.00	0.0	0.0
0.41	0.00	0.0	0.0
1.49	0.00	0.0	0.0
1.82	61.21	10.1	10.1
1.83	0.00	0.3	10.4
2.49	0.00	0.0	10.4

-x Infiltration Storage Chambers (0 m3)  
 0.33m Static Ponding Depth (10.1 m3)

4837 Albion Road - Hard Rock Ottawa (116111)  
PCSWMM Storage Curves - Proposed Conditions

STM ID	CB ID	Provided Storage	
		Underground	Surface
EX-CB82	A-20	6.8	78.7
Depth (m)	Equivalent Area (m <sup>2</sup> )	Incremental Volume (m <sup>3</sup> )	Total Volume (m <sup>3</sup> )
0.00	0.00	0.0	0.0
0.40	34.00	6.8	6.8
0.41	0.00	0.2	7.0
1.22	0.00	0.0	7.0
1.43	749.52	78.7	85.7
1.44	0.00	3.7	89.4
2.22	0.00	0.0	89.4

EX-10x Infiltration Storage Chambers (6.8 m<sup>3</sup>)  
0.21m Static Ponding Depth (78.7 m<sup>3</sup>)

STM ID	CB ID	Provided Storage	
		Underground	Surface
EX-CB84	A-21	6.8	168.4
Depth (m)	Equivalent Area (m <sup>2</sup> )	Incremental Volume (m <sup>3</sup> )	Total Volume (m <sup>3</sup> )
0.00	0.00	0.0	0.0
0.40	34.00	6.8	6.8
0.41	0.00	0.2	7.0
1.53	0.00	0.0	7.0
1.88	962.29	168.4	175.4
1.89	0.00	4.8	180.2
2.53	0.00	0.0	180.2

EX-10x Infiltration Storage Chambers (6.8 m<sup>3</sup>)  
0.35m Static Ponding Depth (168.4 m<sup>3</sup>)

STM ID	CB ID	Provided Storage	
		Underground	Surface
EX-CB87	A-17a	6.8	124.3
Depth (m)	Equivalent Area (m <sup>2</sup> )	Incremental Volume (m <sup>3</sup> )	Total Volume (m <sup>3</sup> )
0.00	0.00	0.0	0.0
0.40	34.00	6.8	6.8
0.41	0.00	0.2	7.0
1.18	0.00	0.0	7.0
1.45	920.74	124.3	131.3
1.46	0.00	4.6	135.9
2.18	0.00	0.0	135.9

EX-10x Infiltration Storage Chambers (6.8 m<sup>3</sup>)  
0.27m Static Ponding Depth (124.3 m<sup>3</sup>)

STM ID	CB ID	Provided Storage	
		Underground	Surface
EX-CB90	A-17b	6.8	85.8
Depth (m)	Equivalent Area (m <sup>2</sup> )	Incremental Volume (m <sup>3</sup> )	Total Volume (m <sup>3</sup> )
0.00	0.00	0.0	0.0
0.40	34.00	6.8	6.8
0.41	0.00	0.2	7.0
1.29	0.00	0.0	7.0
1.44	1144.00	85.8	92.8
1.45	0.00	5.7	98.5
2.29	0.00	0.0	98.5

EX-10x Infiltration Storage Chambers (6.8 m<sup>3</sup>)  
0.15m Static Ponding Depth (85.8 m<sup>3</sup>)

4837 Albion Road - Hard Rock Ottawa (116111)  
PCSWMM Storage Curves - Proposed Conditions

STM ID	CB ID	Provided Storage	
		Underground	Surface
<b>EX-CB92</b>	<b>A-17c</b>	<b>6.8</b>	<b>110.7</b>
Depth (m)	Equivalent Area (m <sup>2</sup> )	Incremental Volume (m <sup>3</sup> )	Total Volume (m <sup>3</sup> )
0.00	0.00	0.0	0.0
0.40	34.00	6.8	6.8
0.41	0.00	0.2	7.0
1.18	0.00	0.0	7.0
1.46	790.71	110.7	117.7
1.47	0.00	4.0	121.6
2.18	0.00	0.0	121.6

EX-10x Infiltration Storage Chambers (6.8 m<sup>3</sup>)  
0.28m Static Ponding Depth (110.7 m<sup>3</sup>)

STM ID	CB ID	Provided Storage	
		Underground	Surface
<b>EX-CB95</b>	<b>A-25</b>	<b>6.8</b>	<b>22.0</b>
Depth (m)	Equivalent Area (m <sup>2</sup> )	Incremental Volume (m <sup>3</sup> )	Total Volume (m <sup>3</sup> )
0.00	0.00	0.0	0.0
0.40	34.00	6.8	6.8
0.41	0.00	0.2	7.0
1.22	0.00	0.0	7.0
1.50	157.14	22.0	29.0
1.51	0.00	0.8	29.8
2.22	0.00	0.0	29.8

EX-10x Infiltration Storage Chambers (6.8 m<sup>3</sup>)  
0.28m Static Ponding Depth (22 m<sup>3</sup>)

STM ID	CB ID	Provided Storage	
		Underground	Surface
<b>EX-CB96</b>	<b>A-17d</b>	<b>6.8</b>	<b>211.8</b>
Depth (m)	Equivalent Area (m <sup>2</sup> )	Incremental Volume (m <sup>3</sup> )	Total Volume (m <sup>3</sup> )
0.00	0.00	0.0	0.0
0.40	34.00	6.8	6.8
0.41	0.00	0.2	7.0
1.40	0.00	0.0	7.0
1.73	1283.64	211.8	218.8
1.74	0.00	6.4	225.2
2.40	0.00	0.0	225.2

EX-10x Infiltration Storage Chambers (6.8 m<sup>3</sup>)  
0.33m Static Ponding Depth (211.8 m<sup>3</sup>)

STM ID	CB ID	Provided Storage	
		Underground	Surface
<b>PR-CB01</b>	<b>A-47</b>	<b>0.0</b>	<b>26.3</b>
Depth (m)	Equivalent Area (m <sup>2</sup> )	Incremental Volume (m <sup>3</sup> )	Total Volume (m <sup>3</sup> )
0.00	0.00	0.0	0.0
0.40	0.00	0.0	0.0
0.41	0.00	0.0	0.0
1.00	0.00	0.0	0.0
1.20	263.00	26.3	26.3
1.21	0.00	1.3	27.6
2.00	0.00	0.0	27.6

-x Stormtech STC-740 Storage Chambers (0 m<sup>3</sup>)  
0.2m Static Ponding Depth (26.3 m<sup>3</sup>)

4837 Albion Road - Hard Rock Ottawa (116111)  
PCSWMM Storage Curves - Proposed Conditions

STM ID	CB ID	Provided Storage	
		Underground	Surface
PR-CB02	A-48	0.0	38.5
Depth (m)	Equivalent Area (m <sup>2</sup> )	Incremental Volume (m <sup>3</sup> )	Total Volume (m <sup>3</sup> )
0.00	0.00	0.0	0.0
0.76	0.00	0.0	0.0
0.77	0.00	0.0	0.0
0.95	0.00	0.0	0.0
1.19	320.83	38.5	38.5
1.20	0.00	1.6	40.1
1.95	0.00	0.0	40.1

-x Stormtech STC-740 Storage Chambers (0 m3)  
0.24m Static Ponding Depth (38.5 m3)

STM ID	CB ID	Provided Storage	
		Underground	Surface
PR-CB03	A-49	0.0	26.4
Depth (m)	Equivalent Area (m <sup>2</sup> )	Incremental Volume (m <sup>3</sup> )	Total Volume (m <sup>3</sup> )
0.00	0.00	0.0	0.0
0.76	0.00	0.0	0.0
0.77	0.00	0.0	0.0
1.00	0.00	0.0	0.0
1.24	220.00	26.4	26.4
1.25	0.00	1.1	27.5
2.00	0.00	0.0	27.5

-x Stormtech STC-740 Storage Chambers (0 m3)  
0.24m Static Ponding Depth (26.4 m3)

STM ID	CB ID	Provided Storage	
		Underground	Surface
PR-CB04	A-51	25.4	59.2
Depth (m)	Equivalent Area (m <sup>2</sup> )	Incremental Volume (m <sup>3</sup> )	Total Volume (m <sup>3</sup> )
0.00	0.00	0.0	0.0
0.76	66.84	25.4	25.4
0.77	0.00	0.3	25.7
1.60	0.00	0.0	25.7
1.85	473.60	59.2	84.9
1.86	0.00	2.4	87.3
2.60	0.00	0.0	87.3

12x Stormtech STC-740 Storage Chambers (25.4 m3)  
0.25m Static Ponding Depth (59.2 m3)

STM ID	CB ID	Provided Storage	
		Underground	Surface
PR-CB05	A-56	0.0	60.4
Depth (m)	Equivalent Area (m <sup>2</sup> )	Incremental Volume (m <sup>3</sup> )	Total Volume (m <sup>3</sup> )
0.00	0.00	0.0	0.0
0.76	0.00	0.0	0.0
0.77	0.00	0.0	0.0
1.00	0.00	0.0	0.0
1.25	483.20	60.4	60.4
1.26	0.00	2.4	62.8
2.00	0.00	0.0	62.8

-x Stormtech STC-740 Storage Chambers (0 m3)  
0.25m Static Ponding Depth (60.4 m3)

4837 Albion Road - Hard Rock Ottawa (116111)  
PCSWMM Storage Curves - Proposed Conditions

STM ID	CB ID	Provided Storage	
		Underground	Surface
PR-CB08	A-61	0.0	65.3
Depth (m)	Equivalent Area (m <sup>2</sup> )	Incremental Volume (m <sup>3</sup> )	Total Volume (m <sup>3</sup> )
0.00	0.00	0.0	0.0
0.76	0.00	0.0	0.0
0.77	0.00	0.0	0.0
1.05	0.00	0.0	0.0
1.30	522.40	65.3	65.3
1.31	0.00	2.6	67.9
2.05	0.00	0.0	67.9

-x Stormtech STC-740 Storage Chambers (0 m3)  
0.25m Static Ponding Depth (65.3 m3)

STM ID	CB ID	Provided Storage	
		Underground	Surface
PR-CB09	A-62	0.0	72.9
Depth (m)	Equivalent Area (m <sup>2</sup> )	Incremental Volume (m <sup>3</sup> )	Total Volume (m <sup>3</sup> )
0.00	0.00	0.0	0.0
0.76	0.00	0.0	0.0
0.77	0.00	0.0	0.0
1.15	0.00	0.0	0.0
1.40	583.20	72.9	72.9
1.41	0.00	2.9	75.8
2.15	0.00	0.0	75.8

-x Stormtech STC-740 Storage Chambers (0 m3)  
0.25m Static Ponding Depth (72.9 m3)

STM ID	CB ID	Provided Storage	
		Underground	Surface
PR-CB11	A-67	0.0	64.0
Depth (m)	Equivalent Area (m <sup>2</sup> )	Incremental Volume (m <sup>3</sup> )	Total Volume (m <sup>3</sup> )
0.00	0.00	0.0	0.0
0.76	0.00	0.0	0.0
0.77	0.00	0.0	0.0
1.00	0.00	0.0	0.0
1.25	512.00	64.0	64.0
1.26	0.00	2.6	66.6
2.00	0.00	0.0	66.6

-x Stormtech STC-740 Storage Chambers (0 m3)  
0.25m Static Ponding Depth (64 m3)

STM ID	CB ID	Provided Storage	
		Underground	Surface
PR-CB12	A-66	0.0	107.4
Depth (m)	Equivalent Area (m <sup>2</sup> )	Incremental Volume (m <sup>3</sup> )	Total Volume (m <sup>3</sup> )
0.00	0.00	0.0	0.0
0.76	0.00	0.0	0.0
0.77	0.00	0.0	0.0
1.18	0.00	0.0	0.0
1.45	795.56	107.4	107.4
1.46	0.00	4.0	111.4
2.18	0.00	0.0	111.4

-x Stormtech STC-740 Storage Chambers (0 m3)  
0.27m Static Ponding Depth (107.4 m3)



4837 Albion Road - Hard Rock Ottawa (116111)  
 PCSWMM Storage Curves - Proposed Conditions

STM ID	CB ID	Provided Storage	
		Underground	Surface
PR-CB13	A-36	8.4	0.8
Depth (m)	Equivalent Area (m <sup>2</sup> )	Incremental Volume (m <sup>3</sup> )	Total Volume (m <sup>3</sup> )
0.00	0.00	0.0	0.0
0.76	22.11	8.4	8.4
0.77	0.00	0.1	8.5
1.75	0.00	0.0	8.5
1.82	22.86	0.8	9.3
1.83	0.00	0.1	9.4
2.75	0.00	0.0	9.4

4x Stormtech STC-740 Storage Chambers (8.4 m<sup>3</sup>)  
 0.07m Static Ponding Depth (0.8 m<sup>3</sup>)

STM ID	CB ID	Provided Storage	
		Underground	Surface
PR-CB14	A-37	8.4	3.7
Depth (m)	Equivalent Area (m <sup>2</sup> )	Incremental Volume (m <sup>3</sup> )	Total Volume (m <sup>3</sup> )
0.00	0.00	0.0	0.0
0.76	22.11	8.4	8.4
0.77	0.00	0.1	8.5
1.75	0.00	0.0	8.5
1.85	74.00	3.7	12.2
1.86	0.00	0.4	12.6
2.75	0.00	0.0	12.6

4x Stormtech STC-740 Storage Chambers (8.4 m<sup>3</sup>)  
 0.1m Static Ponding Depth (3.7 m<sup>3</sup>)

STM ID	CB ID	Provided Storage	
		Underground	Surface
PR-CB15	A-35	0.0	56.4
Depth (m)	Equivalent Area (m <sup>2</sup> )	Incremental Volume (m <sup>3</sup> )	Total Volume (m <sup>3</sup> )
0.00	0.00	0.0	0.0
0.76	0.00	0.0	0.0
0.77	0.00	0.0	0.0
1.20	0.00	0.0	0.0
1.47	417.78	56.4	56.4
1.48	0.00	2.1	58.5
2.20	0.00	0.0	58.5

-x Stormtech STC-740 Storage Chambers (0 m<sup>3</sup>)  
 0.27m Static Ponding Depth (56.4 m<sup>3</sup>)

STM ID	CB ID	Provided Storage	
		Underground	Surface
PR-CB16/17	A-18	0.0	211.9
Depth (m)	Equivalent Area (m <sup>2</sup> )	Incremental Volume (m <sup>3</sup> )	Total Volume (m <sup>3</sup> )
0.00	0.00	0.0	0.0
0.76	0.00	0.0	0.0
0.77	0.00	0.0	0.0
1.26	0.00	0.0	0.0
1.56	1412.67	211.9	211.9
1.57	0.00	7.1	219.0
2.26	0.00	0.0	219.0

-x Stormtech STC-740 Storage Chambers (0 m<sup>3</sup>)  
 0.3m Static Ponding Depth (211.9 m<sup>3</sup>)

4837 Albion Road - Hard Rock Ottawa (116111)  
 PCSWMM Storage Curves - Proposed Conditions

STM ID	CB ID	Provided Storage	
		Underground	Surface
PR-CB18	A-13	8.4	4.2
Depth (m)	Equivalent Area (m <sup>2</sup> )	Incremental Volume (m <sup>3</sup> )	Total Volume (m <sup>3</sup> )
0.00	0.00	0.0	0.0
0.76	22.11	8.4	8.4
0.77	0.00	0.1	8.5
1.56	0.00	0.0	8.5
1.71	56.00	4.2	12.7
1.72	0.00	0.3	13.0
2.56	0.00	0.0	13.0

-x Stormtech STC-740 Storage Chambers (8.4 m<sup>3</sup>)  
 0.15m Static Ponding Depth (4.2 m<sup>3</sup>)

STM ID	CB ID	Provided Storage	
		Underground	Surface
PR-CB19	A-05	0.0	6.6
Depth (m)	Equivalent Area (m <sup>2</sup> )	Incremental Volume (m <sup>3</sup> )	Total Volume (m <sup>3</sup> )
0.00	0.00	0.0	0.0
0.76	0.00	0.0	0.0
0.77	0.00	0.0	0.0
1.40	0.00	0.0	0.0
1.55	88.00	6.6	6.6
1.56	0.00	0.4	7.0
2.40	0.00	0.0	7.0

-x Stormtech STC-740 Storage Chambers (0 m<sup>3</sup>)  
 0.15m Static Ponding Depth (6.6 m<sup>3</sup>)

STM ID	CB ID	Provided Storage	
		Underground	Surface
PR-CB20	A-03	0.0	4.5
Depth (m)	Equivalent Area (m <sup>2</sup> )	Incremental Volume (m <sup>3</sup> )	Total Volume (m <sup>3</sup> )
0.00	0.00	0.0	0.0
0.76	0.00	0.0	0.0
0.77	0.00	0.0	0.0
1.20	0.00	0.0	0.0
1.35	60.00	4.5	4.5
1.36	0.00	0.3	4.8
2.20	0.00	0.0	4.8

-x Stormtech STC-740 Storage Chambers (0 m<sup>3</sup>)  
 0.15m Static Ponding Depth (4.5 m<sup>3</sup>)

STM ID	CB ID	Provided Storage	
		Underground	Surface
PR-CB21	A-11	0.0	37.1
Depth (m)	Equivalent Area (m <sup>2</sup> )	Incremental Volume (m <sup>3</sup> )	Total Volume (m <sup>3</sup> )
0.00	0.00	0.0	0.0
0.76	0.00	0.0	0.0
0.77	0.00	0.0	0.0
1.64	0.00	0.0	0.0
1.84	371.00	37.1	37.1
1.85	0.00	1.9	39.0
2.64	0.00	0.0	39.0

-x Stormtech STC-740 Storage Chambers (0 m<sup>3</sup>)  
 0.2m Static Ponding Depth (37.1 m<sup>3</sup>)

4837 Albion Road - Hard Rock Ottawa (116111)  
 PCSWMM Storage Curves - Proposed Conditions

STM ID	CB ID	Provided Storage	
		Underground	Surface
PR-CB22	A-06	0.0	37.4
Depth (m)	Equivalent Area (m <sup>2</sup> )	Incremental Volume (m <sup>3</sup> )	Total Volume (m <sup>3</sup> )
0.00	0.00	0.0	0.0
0.76	0.00	0.0	0.0
0.77	0.00	0.0	0.0
1.40	0.00	0.0	0.0
1.60	374.00	37.4	37.4
1.61	0.00	1.9	39.3
2.40	0.00	0.0	39.3

-x Stormtech STC-740 Storage Chambers (0 m3)  
 0.2m Static Ponding Depth (37.4 m3)

STM ID	CB ID	Provided Storage	
		Underground	Surface
PR-CB23	A-02	0.0	32.0
Depth (m)	Equivalent Area (m <sup>2</sup> )	Incremental Volume (m <sup>3</sup> )	Total Volume (m <sup>3</sup> )
0.00	0.00	0.0	0.0
0.76	0.00	0.0	0.0
0.77	0.00	0.0	0.0
1.20	0.00	0.0	0.0
1.40	320.00	32.0	32.0
1.41	0.00	1.6	33.6
2.20	0.00	0.0	33.6

-x Stormtech STC-740 Storage Chambers (0 m3)  
 0.2m Static Ponding Depth (32 m3)

STM ID	CB ID	Provided Storage	
		Underground	Surface
PR-CB24	A-10	0.0	121.5
Depth (m)	Equivalent Area (m <sup>2</sup> )	Incremental Volume (m <sup>3</sup> )	Total Volume (m <sup>3</sup> )
0.00	0.00	0.0	0.0
0.76	0.00	0.0	0.0
0.77	0.00	0.0	0.0
1.60	0.00	0.0	0.0
1.90	810.00	121.5	121.5
1.91	0.00	4.1	125.6
2.60	0.00	0.0	125.6

-x Stormtech STC-740 Storage Chambers (0 m3)  
 0.3m Static Ponding Depth (121.5 m3)

STM ID	CB ID	Provided Storage	
		Underground	Surface
PR-CB25	A-07	0.0	117.1
Depth (m)	Equivalent Area (m <sup>2</sup> )	Incremental Volume (m <sup>3</sup> )	Total Volume (m <sup>3</sup> )
0.00	0.00	0.0	0.0
0.76	0.00	0.0	0.0
0.77	0.00	0.0	0.0
1.41	0.00	0.0	0.0
1.71	780.67	117.1	117.1
1.72	0.00	3.9	121.0
2.41	0.00	0.0	121.0

-x Stormtech STC-740 Storage Chambers (0 m3)  
 0.3m Static Ponding Depth (117.1 m3)

4837 Albion Road - Hard Rock Ottawa (116111)  
PCSWMM Storage Curves - Proposed Conditions

STM ID	CB ID	Provided Storage	
		Underground	Surface
PR-CB26	A-01	0.0	96.0
Depth (m)	Equivalent Area (m <sup>2</sup> )	Incremental Volume (m <sup>3</sup> )	Total Volume (m <sup>3</sup> )
0.00	0.00	0.0	0.0
0.76	0.00	0.0	0.0
0.77	0.00	0.0	0.0
1.20	0.00	0.0	0.0
1.50	640.00	96.0	96.0
1.51	0.00	3.2	99.2
2.20	0.00	0.0	99.2

-x Stormtech STC-740 Storage Chambers (0 m3)  
0.3m Static Ponding Depth (96 m3)

STM ID	CB ID	Provided Storage	
		Underground	Surface
PR-CB27	A-09	0.0	120.7
Depth (m)	Equivalent Area (m <sup>2</sup> )	Incremental Volume (m <sup>3</sup> )	Total Volume (m <sup>3</sup> )
0.00	0.00	0.0	0.0
0.76	0.00	0.0	0.0
0.77	0.00	0.0	0.0
1.39	0.00	0.0	0.0
1.69	804.67	120.7	120.7
1.70	0.00	4.0	124.7
2.39	0.00	0.0	124.7

-x Stormtech STC-740 Storage Chambers (0 m3)  
0.3m Static Ponding Depth (120.7 m3)

STM ID	CB ID	Provided Storage	
		Underground	Surface
PR-CB28	A-08	0.0	112.4
Depth (m)	Equivalent Area (m <sup>2</sup> )	Incremental Volume (m <sup>3</sup> )	Total Volume (m <sup>3</sup> )
0.00	0.00	0.0	0.0
0.76	0.00	0.0	0.0
0.77	0.00	0.0	0.0
1.20	0.00	0.0	0.0
1.50	749.33	112.4	112.4
1.51	0.00	3.7	116.1
2.20	0.00	0.0	116.1

-x Stormtech STC-740 Storage Chambers (0 m3)  
0.3m Static Ponding Depth (112.4 m3)

STM ID	CB ID	Provided Storage	
		Underground	Surface
PR-CB29	A-43	63.6	49.8
Depth (m)	Equivalent Area (m <sup>2</sup> )	Incremental Volume (m <sup>3</sup> )	Total Volume (m <sup>3</sup> )
0.00	0.00	0.0	0.0
0.76	167.37	63.6	63.6
0.77	0.00	0.8	64.4
1.60	0.00	0.0	64.4
1.85	398.40	49.8	114.2
1.86	0.00	2.0	116.2
2.60	0.00	0.0	116.2

30x Stormtech STC-740 Storage Chambers (63.6 m3)  
0.25m Static Ponding Depth (49.8 m3)

4837 Albion Road - Hard Rock Ottawa (116111)  
PCSWMM Storage Curves - Proposed Conditions

STM ID	CB ID	Provided Storage	
		Underground	Surface
PR-CB30	A-44	0.0	39.2
Depth (m)	Equivalent Area (m <sup>2</sup> )	Incremental Volume (m <sup>3</sup> )	Total Volume (m <sup>3</sup> )
0.00	0.00	0.0	0.0
0.76	0.00	0.0	0.0
0.77	0.00	0.0	0.0
1.00	0.00	0.0	0.0
1.25	313.60	39.2	39.2
1.26	0.00	1.6	40.8
2.00	0.00	0.0	40.8

-x Stormtech STC-740 Storage Chambers (0 m3)  
0.25m Static Ponding Depth (39.2 m3)

STM ID	CB ID	Provided Storage	
		Underground	Surface
PR-CB31	A-42	0.0	70.5
Depth (m)	Equivalent Area (m <sup>2</sup> )	Incremental Volume (m <sup>3</sup> )	Total Volume (m <sup>3</sup> )
0.00	0.00	0.0	0.0
0.76	0.00	0.0	0.0
0.77	0.00	0.0	0.0
1.20	0.00	0.0	0.0
1.45	564.00	70.5	70.5
1.46	0.00	2.8	73.3
2.20	0.00	0.0	73.3

-x Stormtech STC-740 Storage Chambers (0 m3)  
0.25m Static Ponding Depth (70.5 m3)

STM ID	CB ID	Provided Storage	
		Underground	Surface
PR-CB32	A-40	59.3	3.0
Depth (m)	Equivalent Area (m <sup>2</sup> )	Incremental Volume (m <sup>3</sup> )	Total Volume (m <sup>3</sup> )
0.00	0.00	0.0	0.0
0.76	156.05	59.3	59.3
0.77	0.00	0.8	60.1
2.25	0.00	0.0	60.1
2.35	60.00	3.0	63.1
2.36	0.00	0.3	63.4
3.25	0.00	0.0	63.4

28x Stormtech STC-740 Storage Chambers (59.3 m3)  
0.1m Static Ponding Depth (3 m3)

STM ID	CB ID	Provided Storage	
		Underground	Surface
PR-CB35	A-58	0.0	6.8
Depth (m)	Equivalent Area (m <sup>2</sup> )	Incremental Volume (m <sup>3</sup> )	Total Volume (m <sup>3</sup> )
0.00	0.00	0.0	0.0
0.76	0.00	0.0	0.0
0.77	0.00	0.0	0.0
1.30	0.00	0.0	0.0
1.55	54.40	6.8	6.8
1.56	0.00	0.3	7.1
2.30	0.00	0.0	7.1

-x Stormtech STC-740 Storage Chambers (0 m3)  
0.25m Static Ponding Depth (6.8 m3)

4837 Albion Road - Hard Rock Ottawa (116111)  
PCSWMM Storage Curves - Proposed Conditions

STM ID	CB ID	Provided Storage	
		Underground	Surface
<b>PR-CB36</b>	<b>A-50</b>	<b>6.3</b>	<b>24.3</b>
Depth (m)	Equivalent Area (m <sup>2</sup> )	Incremental Volume (m <sup>3</sup> )	Total Volume (m <sup>3</sup> )
0.00	0.00	0.0	0.0
0.76	16.58	6.3	6.3
0.77	0.00	0.1	6.4
1.60	0.00	0.0	6.4
1.81	231.43	24.3	30.7
1.82	0.00	1.2	31.8
2.60	0.00	0.0	31.8

3x Stormtech STC-740 Storage Chambers (6.3 m3)

0.21m Static Ponding Depth (24.3 m3)

STM ID	CB ID	Provided Storage	
		Underground	Surface
<b>PR-CB40</b>	<b>A-45</b>	<b>12.7</b>	<b>52.0</b>
Depth (m)	Equivalent Area (m <sup>2</sup> )	Incremental Volume (m <sup>3</sup> )	Total Volume (m <sup>3</sup> )
0.00	0.00	0.0	0.0
0.76	33.42	12.7	12.7
0.77	0.00	0.2	12.9
1.50	0.00	0.0	12.9
1.75	416.00	52.0	64.9
1.76	0.00	2.1	66.9
2.50	0.00	0.0	66.9

6x Stormtech STC-740 Storage Chambers (12.7 m3)

0.25m Static Ponding Depth (52 m3)

STM ID	CB ID	Provided Storage	
		Underground	Surface
<b>PR-CBMH104</b>	<b>A-55</b>	<b>16.9</b>	<b>41.0</b>
Depth (m)	Equivalent Area (m <sup>2</sup> )	Incremental Volume (m <sup>3</sup> )	Total Volume (m <sup>3</sup> )
0.00	0.00	0.0	0.0
0.76	44.47	16.9	16.9
0.77	0.00	0.2	17.1
1.46	0.00	0.0	17.1
1.71	328.00	41.0	58.1
1.72	0.00	1.6	59.8
2.46	0.00	0.0	59.8

8x Stormtech STC-740 Storage Chambers (16.9 m3)

0.25m Static Ponding Depth (41 m3)

STM ID	CB ID	Provided Storage	
		Underground	Surface
<b>PR-CBMH105</b>	<b>A-54</b>	<b>25.4</b>	<b>22.3</b>
Depth (m)	Equivalent Area (m <sup>2</sup> )	Incremental Volume (m <sup>3</sup> )	Total Volume (m <sup>3</sup> )
0.00	0.00	0.0	0.0
0.76	66.84	25.4	25.4
0.77	0.00	0.3	25.7
1.60	0.00	0.0	25.7
1.85	178.40	22.3	48.0
1.86	0.00	0.9	48.9
2.60	0.00	0.0	48.9

12x Stormtech STC-740 Storage Chambers (25.4 m3)

0.25m Static Ponding Depth (22.3 m3)

4837 Albion Road - Hard Rock Ottawa (116111)  
PCSWMM Storage Curves - Proposed Conditions

STM ID	CB ID	Provided Storage	
		Underground	Surface
PR-CBMH106	A-60	33.9	119.8
Depth (m)	Equivalent Area (m <sup>2</sup> )	Incremental Volume (m <sup>3</sup> )	Total Volume (m <sup>3</sup> )
0.00	0.00	0.0	0.0
0.76	89.21	33.9	33.9
0.77	0.00	0.4	34.3
1.49	0.00	0.0	34.3
1.79	798.67	119.8	154.1
1.80	0.00	4.0	158.1
2.49	0.00	0.0	158.1

16x Stormtech STC-740 Storage Chambers (33.9 m<sup>3</sup>)

0.3m Static Ponding Depth (119.8 m<sup>3</sup>)

STM ID	CB ID	Provided Storage	
		Underground	Surface
PR-CBMH107	A-69	25.4	50.3
Depth (m)	Equivalent Area (m <sup>2</sup> )	Incremental Volume (m <sup>3</sup> )	Total Volume (m <sup>3</sup> )
0.00	0.00	0.0	0.0
0.76	66.84	25.4	25.4
0.77	0.00	0.3	25.7
1.56	0.00	0.0	25.7
1.86	335.33	50.3	76.0
1.87	0.00	1.7	77.7
2.56	0.00	0.0	77.7

12x Stormtech STC-740 Storage Chambers (25.4 m<sup>3</sup>)

0.3m Static Ponding Depth (50.3 m<sup>3</sup>)

STM ID	CB ID	Provided Storage	
		Underground	Surface
PR-CBMH108	A-63	38.1	72.5
Depth (m)	Equivalent Area (m <sup>2</sup> )	Incremental Volume (m <sup>3</sup> )	Total Volume (m <sup>3</sup> )
0.00	0.00	0.0	0.0
0.76	100.26	38.1	38.1
0.77	0.00	0.5	38.6
1.59	0.00	0.0	38.6
1.84	580.00	72.5	111.1
1.85	0.00	2.9	114.0
2.59	0.00	0.0	114.0

18x Stormtech STC-740 Storage Chambers (38.1 m<sup>3</sup>)

0.25m Static Ponding Depth (72.5 m<sup>3</sup>)

STM ID	CB ID	Provided Storage	
		Underground	Surface
PR-CBMH109	A-65	106.0	137.4
Depth (m)	Equivalent Area (m <sup>2</sup> )	Incremental Volume (m <sup>3</sup> )	Total Volume (m <sup>3</sup> )
0.00	0.00	0.0	0.0
0.76	278.95	106.0	106.0
0.77	0.00	1.4	107.4
1.64	0.00	0.0	107.4
1.94	916.00	137.4	244.8
1.95	0.00	4.6	249.4
2.64	0.00	0.0	249.4

50x Stormtech STC-740 Storage Chambers (106 m<sup>3</sup>)

0.3m Static Ponding Depth (137.4 m<sup>3</sup>)

4837 Albion Road - Hard Rock Ottawa (116111)  
PCSWMM Storage Curves - Proposed Conditions

STM ID	CB ID	Provided Storage	
		Underground	Surface
PR-CBMH110	A-33	84.8	48.2
Depth (m)	Equivalent Area (m <sup>2</sup> )	Incremental Volume (m <sup>3</sup> )	Total Volume (m <sup>3</sup> )
0.00	0.00	0.0	0.0
0.76	223.16	84.8	84.8
0.77	0.00	1.1	85.9
1.78	0.00	0.0	85.9
1.98	482.00	48.2	134.1
1.99	0.00	2.4	136.5
2.78	0.00	0.0	136.5

40x Stormtech STC-740 Storage Chambers (84.8 m<sup>3</sup>)

0.2m Static Ponding Depth (48.2 m<sup>3</sup>)

STM ID	CB ID	Provided Storage	
		Underground	Surface
PR-CBMH111	A-12	63.6	7.3
Depth (m)	Equivalent Area (m <sup>2</sup> )	Incremental Volume (m <sup>3</sup> )	Total Volume (m <sup>3</sup> )
0.00	0.00	0.0	0.0
0.76	167.37	63.6	63.6
0.77	0.00	0.8	64.4
2.05	0.00	0.0	64.4
2.20	97.33	7.3	71.7
2.21	0.00	0.5	72.2
3.05	0.00	0.0	72.2

30x Stormtech STC-740 Storage Chambers (63.6 m<sup>3</sup>)

0.15m Static Ponding Depth (7.3 m<sup>3</sup>)

STM ID	CB ID	Provided Storage	
		Underground	Surface
PR-CBMH112	A-14	148.4	35.5
Depth (m)	Equivalent Area (m <sup>2</sup> )	Incremental Volume (m <sup>3</sup> )	Total Volume (m <sup>3</sup> )
0.00	0.00	0.0	0.0
0.76	390.53	148.4	148.4
0.77	0.00	2.0	150.4
2.08	0.00	0.0	150.4
2.28	355.00	35.5	185.9
2.29	0.00	1.8	187.6
3.08	0.00	0.0	187.6

70x Stormtech STC-740 Storage Chambers (148.4 m<sup>3</sup>)

0.2m Static Ponding Depth (35.5 m<sup>3</sup>)

STM ID	CB ID	Provided Storage	
		Underground	Surface
PR-CBMH114	A-15	148.4	118.8
Depth (m)	Equivalent Area (m <sup>2</sup> )	Incremental Volume (m <sup>3</sup> )	Total Volume (m <sup>3</sup> )
0.00	0.00	0.0	0.0
0.76	390.53	148.4	148.4
0.77	0.00	2.0	150.4
2.04	0.00	0.0	150.4
2.34	792.00	118.8	269.2
2.35	0.00	4.0	273.1
3.04	0.00	0.0	273.1

70x Stormtech STC-740 Storage Chambers (148.4 m<sup>3</sup>)

0.3m Static Ponding Depth (118.8 m<sup>3</sup>)



4837 Albion Road - Hard Rock Ottawa (116111)  
 PCSWMM Storage Curves - Proposed Conditions

STM ID	CB ID	Provided Storage	
		Underground	Surface
PR-CBMH115	A-16	84.8	110.6
Depth (m)	Equivalent Area (m <sup>2</sup> )	Incremental Volume (m <sup>3</sup> )	Total Volume (m <sup>3</sup> )
0.00	0.00	0.0	0.0
0.76	223.16	84.8	84.8
0.77	0.00	1.1	85.9
2.01	0.00	0.0	85.9
2.31	737.33	110.6	196.5
2.32	0.00	3.7	200.2
3.01	0.00	0.0	200.2

40x Stormtech STC-740 Storage Chambers (84.8 m<sup>3</sup>)  
 0.3m Static Ponding Depth (110.6 m<sup>3</sup>)

STM ID	CB ID	Provided Storage	
		Underground	Surface
PR-CBMH118	A-41	95.4	27.8
Depth (m)	Equivalent Area (m <sup>2</sup> )	Incremental Volume (m <sup>3</sup> )	Total Volume (m <sup>3</sup> )
0.00	0.00	0.0	0.0
0.76	251.05	95.4	95.4
0.77	0.00	1.3	96.7
1.66	0.00	0.0	96.7
1.91	222.40	27.8	124.5
1.92	0.00	1.1	125.6
2.66	0.00	0.0	125.6

45x Stormtech STC-740 Storage Chambers (95.4 m<sup>3</sup>)  
 0.25m Static Ponding Depth (27.8 m<sup>3</sup>)

STM ID	CB ID	Provided Storage	
		Underground	Surface
PR-TD1	A-70	0.0	121.4
Depth (m)	Equivalent Area (m <sup>2</sup> )	Incremental Volume (m <sup>3</sup> )	Total Volume (m <sup>3</sup> )
0.00	0.00	0.0	0.0
0.76	0.00	0.0	0.0
0.77	0.00	0.0	0.0
0.80	0.00	0.0	0.0
1.85	231.24	121.4	121.4
1.86	0.00	1.2	122.6
1.80	0.00	0.0	122.6

-x Stormtech STC-740 Storage Chambers (0 m<sup>3</sup>)  
 1.05m Static Ponding Depth (121.4 m<sup>3</sup>)

4837 Albion Road - Hard Rock Ottawa (116111)  
 PCSWMM Model Results - Proposed Conditions (ICDs)

CB / CBMH ID	PCSWMM Orifice Dia. (mm)	IPEX ICD Type (model)	Outlet Pipe Dia. (mm)	Structure Dia. (mm)	Release Rate (L/s) <sup>1</sup>				Head (m) <sup>1</sup>			
					2-yr	5-yr	100-yr	100-yr (+20%)	2-yr	5-yr	100-yr	100-yr (+20%)
EX-CB117	75	HF-77	250	600x600	12.5	13.4	14.1	14.3	1.14	1.29	1.44	1.50
EX-CB134	83	HF-85	200	600x600	13.7	18.2	19.4	19.5	0.91	1.59	1.81	1.81
EX-CB137	135	HF-137	200	600x600	19.8	36.2	47.3	47.8	0.33	0.94	1.58	1.62
EX-CB14	127	HF-130	200	600x600	53.8	55.0	57.6	58.4	2.53	2.64	2.89	2.97
EX-CB60	108	HF-110	250	600x600	29.1	31.0	31.6	31.6	1.44	1.62	1.69	1.72
EX-CB64	65	LMF-100	250	600x600	5.2	10.7	11.0	11.0	0.37	1.44	1.56	1.58
EX-CB72	65	LMF-100	200	600x600	7.9	10.9	11.6	11.8	0.80	1.50	1.70	1.76
EX-CB82	200	HF-202	200	600x600	80.7	92.2	96.3	97.8	1.00	1.28	1.39	1.43
EX-CB84	115	HF-118	200	600x600	31.9	34.6	35.5	35.8	1.35	1.58	1.66	1.68
EX-MH105	200	HF-199	450	1200	108.1	119.6	122.3	123.2	1.91	2.29	2.39	2.43
EX-MH112	250	HF-218	300	1200	95.7	112.8	116.8	117.6	1.05	1.39	1.50	1.54
PR-CB13	55	LMF-85	250	600x600	3.9	5.0	8.0	8.0	0.40	0.64	1.58	1.59
PR-CB14	55	LMF-85	250	600x600	2.7	3.5	7.9	8.0	0.20	0.32	1.61	1.63
PR-CB16/17	200	HF-202	250	600x600	71.8	92.8	97.0	97.7	0.81	1.29	1.41	1.48
PR-CB18	60	LMF-95	250	600x600	4.3	5.2	9.1	9.2	0.35	0.48	1.45	1.47
PR-CB29	55	LMF-85	250	600x600	2.4	3.1	4.4	8.0	0.17	0.25	0.49	1.60
PR-CB32	55	LMF-80	300	600x600	2.2	2.9	8.2	7.9	0.23	0.35	2.06	2.10
PR-CB36	50	LMF-80	250	600x600	2.4	3.9	6.1	6.2	0.23	0.57	1.34	1.43
PR-CB40	60	LMF-95	250	600x600	8.6	9.6	9.9	10.0	1.29	1.62	1.73	1.76
PR-CB41	55	LMF-85	250	600x600	5.6	7.2	7.6	7.6	0.79	1.31	1.47	1.49
PR-CBMH104	55	LMF-85	250	1200	6.4	7.1	7.3	7.4	1.01	1.24	1.32	1.35
PR-CBMH105	55	LMF-85	250	1200	5.2	7.1	7.5	7.7	0.69	1.25	1.40	1.49
PR-CBMH106	55	LMF-85	250	1200	6.4	7.2	7.5	7.6	1.02	1.29	1.40	1.43
PR-CBMH107	55	LMF-85	250	1200	4.1	6.5	7.9	7.7	0.44	1.08	1.62	1.64
PR-CBMH108	55	LMF-85	250	1200	7.3	7.5	7.8	7.9	1.31	1.40	1.49	1.52
PR-CBMH109	60	LMF-90	300	1200	8.8	9.1	9.4	9.6	1.39	1.49	1.60	1.64
PR-CBMH110	55	LMF-85	250	1200	3.8	4.5	8.5	8.5	0.38	0.51	1.79	1.82
PR-CBMH111	70	LMF-105	300	1200	5.3	6.4	14.4	14.5	0.30	0.41	1.95	1.96
PR-CBMH112	70	LMF-105	300	1200	7.1	14.2	14.7	14.7	0.50	1.90	2.03	2.04
PR-CBMH114	60	LMF-95	300	1200	9.9	10.4	10.8	10.9	1.69	1.89	2.02	2.06
PR-CBMH115	60	LMF-95	300	1200	8.3	10.2	10.5	10.6	1.23	1.84	1.94	1.98
PR-CBMH118	127	HF-130	300	1200	27.9	51.0	54.2	54.2	0.44	1.36	1.64	1.69
PR-MH100	60	LMF-95	450	1200	5.6	8.4	8.7	8.8	0.63	1.30	1.42	1.46
PR-TD02	127	HF-130	200	300x1400	25.8	34.2	35.4	35.7	0.63	1.06	1.13	1.16

<sup>1</sup> 3-hour Chicago Storm.

\*IPEX ICD's sized based on 100-year model results.

4837 Albion Road - Hard Rock Ottawa (116111)  
 PCSWMM Model Results - Proposed Conditions (Ponding)



CB / CBMH ID	Invert Elev. (m)	Rim Elev. (m)	Spill Elev. (m)	Ponding Depth (m)	HGL Elev. (m) <sup>1</sup>				Ponding Depth (m)				Spill Depth (m)			
					2-yr	5-yr	100-yr	100-yr (+20%)	2-yr	5-yr	100-yr	100-yr (+20%)	2-yr	5-yr	100-yr	100-yr (+20%)
EX-CB116	112.99	113.50	113.65	0.15	113.22	113.39	113.53	113.59	0.00	0.00	0.03	0.09	0.00	0.00	0.00	0.00
EX-CB117	112.09	113.35	113.65	0.30	113.23	113.38	113.53	113.59	0.00	0.03	0.18	0.24	0.00	0.00	0.00	0.00
EX-CB128	112.51	113.71	113.90	0.19	113.36	113.71	113.82	113.86	0.00	0.00	0.11	0.15	0.00	0.00	0.00	0.00
EX-CB134	111.60	113.30	113.45	0.15	112.51	113.19	113.41	113.41	0.00	0.00	0.11	0.11	0.00	0.00	0.00	0.00
EX-CB137	112.00	113.40	113.60	0.20	112.33	112.94	113.58	113.62	0.00	0.00	0.18	0.22	0.00	0.00	0.00	0.02
EX-CB14	111.19	113.40	114.10	0.70	113.72	113.83	114.08	114.16	0.32	0.43	0.68	0.76	0.00	0.00	0.00	0.06
EX-CB28	112.43	113.65	114.00	0.35	113.45	113.75	113.85	113.89	0.00	0.10	0.20	0.24	0.00	0.00	0.00	0.00
EX-CB30	112.50	113.70	114.00	0.30	113.46	113.76	113.88	113.92	0.00	0.06	0.18	0.22	0.00	0.00	0.00	0.00
EX-CB50	112.34	113.71	114.00	0.29	113.40	113.75	113.83	113.86	0.00	0.04	0.12	0.15	0.00	0.00	0.00	0.00
EX-CB52	112.44	113.71	113.98	0.27	113.49	113.79	113.88	113.91	0.00	0.08	0.17	0.20	0.00	0.00	0.00	0.00
EX-CB54	112.52	113.83	114.00	0.17	113.50	113.79	113.89	113.92	0.00	0.00	0.06	0.09	0.00	0.00	0.00	0.00
EX-CB58	112.44	113.73	114.00	0.27	113.30	113.76	113.83	113.86	0.00	0.03	0.10	0.13	0.00	0.00	0.00	0.00
EX-CB60	112.15	113.73	113.90	0.17	113.59	113.77	113.84	113.87	0.00	0.04	0.11	0.14	0.00	0.00	0.00	0.00
EX-CB62	112.64	113.76	113.90	0.14	113.59	113.78	113.85	113.88	0.00	0.02	0.09	0.12	0.00	0.00	0.00	0.00
EX-CB64	112.10	113.50	113.65	0.15	112.47	113.54	113.66	113.68	0.00	0.04	0.16	0.18	0.00	0.00	0.01	0.03
EX-CB72	111.18	112.67	113.00	0.33	111.98	112.68	112.88	112.94	0.00	0.01	0.21	0.27	0.00	0.00	0.00	0.00
EX-CB82	112.62	113.84	114.05	0.21	113.62	113.90	114.01	114.05	0.00	0.06	0.17	0.21	0.00	0.00	0.00	0.00
EX-CB84	112.12	113.65	114.00	0.35	113.47	113.70	113.78	113.80	0.00	0.05	0.13	0.15	0.00	0.00	0.00	0.00
EX-CB87	112.50	113.68	113.95	0.27	113.26	113.73	113.83	113.87	0.00	0.05	0.15	0.19	0.00	0.00	0.00	0.00
EX-CB90	112.51	113.80	113.95	0.15	113.24	113.81	113.86	113.88	0.00	0.01	0.06	0.08	0.00	0.00	0.00	0.00
EX-CB92	112.49	113.67	113.95	0.28	113.56	113.77	113.88	113.92	0.00	0.10	0.21	0.25	0.00	0.00	0.00	0.00
EX-CB95	112.45	113.67	113.95	0.28	113.36	113.70	113.81	113.85	0.00	0.03	0.14	0.18	0.00	0.00	0.00	0.00
EX-CB96	112.22	113.62	113.95	0.33	113.35	113.70	113.81	113.84	0.00	0.08	0.19	0.22	0.00	0.00	0.00	0.00

4837 Albion Road - Hard Rock Ottawa (116111)  
 PCSWMM Model Results - Proposed Conditions (Ponding)



CB / CBMH ID	Invert Elev. (m)	Rim Elev. (m)	Spill Elev. (m)	Ponding Depth (m)	HGL Elev. (m) <sup>1</sup>				Ponding Depth (m)				Spill Depth (m)			
					2-yr	5-yr	100-yr	100-yr (+20%)	2-yr	5-yr	100-yr	100-yr (+20%)	2-yr	5-yr	100-yr	100-yr (+20%)
PR-CB01	112.40	113.40	113.60	0.20	112.79	113.46	113.58	113.61	0.00	0.06	0.18	0.21	0.00	0.00	0.00	0.01
PR-CB02	112.45	113.40	113.64	0.24	112.79	113.46	113.58	113.61	0.00	0.06	0.18	0.21	0.00	0.00	0.00	0.00
PR-CB03	112.40	113.40	113.64	0.24	112.79	113.46	113.58	113.65	0.00	0.06	0.18	0.25	0.00	0.00	0.00	0.01
PR-CB04	111.80	113.40	113.65	0.25	112.79	113.46	113.58	113.62	0.00	0.06	0.18	0.22	0.00	0.00	0.00	0.00
PR-CB05	112.45	113.45	113.70	0.25	113.30	113.53	113.61	113.64	0.00	0.08	0.16	0.19	0.00	0.00	0.00	0.00
PR-CB08	112.45	113.50	113.75	0.25	113.28	113.56	113.66	113.70	0.00	0.06	0.16	0.20	0.00	0.00	0.00	0.00
PR-CB09	112.45	113.60	113.85	0.25	113.57	113.66	113.75	113.78	0.00	0.06	0.15	0.18	0.00	0.00	0.00	0.00
PR-CB11	112.60	113.60	113.85	0.25	113.60	113.70	113.82	113.85	0.00	0.10	0.22	0.25	0.00	0.00	0.00	0.00
PR-CB12	112.42	113.60	113.87	0.27	113.60	113.70	113.82	113.85	0.00	0.10	0.22	0.25	0.00	0.00	0.00	0.00
PR-CB13	111.90	113.65	113.72	0.07	112.55	112.79	113.73	113.74	0.00	0.00	0.08	0.09	0.00	0.00	0.01	0.02
PR-CB14	111.80	113.55	113.65	0.10	112.25	112.37	113.66	113.68	0.00	0.00	0.11	0.13	0.00	0.00	0.01	0.03
PR-CB15	112.20	113.40	113.67	0.27	112.31	112.38	113.65	113.68	0.00	0.00	0.25	0.28	0.00	0.00	0.00	0.01
PR-CB16/17	112.09	113.35	113.56	0.21	112.90	113.38	113.50	113.57	0.00	0.03	0.15	0.22	0.00	0.00	0.00	0.01
PR-CB18	113.49	115.05	115.20	0.15	114.09	114.22	115.19	115.21	0.00	0.00	0.14	0.16	0.00	0.00	0.00	0.01
PR-CB19	113.65	115.05	115.20	0.15	113.76	113.79	115.20	115.21	0.00	0.00	0.15	0.16	0.00	0.00	0.00	0.01
PR-CB20	113.85	115.05	115.20	0.15	113.96	113.97	115.20	115.24	0.00	0.00	0.15	0.19	0.00	0.00	0.00	0.04
PR-CB21	113.56	115.20	115.40	0.20	114.14	115.27	115.40	115.41	0.00	0.07	0.20	0.21	0.00	0.00	0.00	0.01
PR-CB22	113.80	115.20	115.40	0.20	114.36	115.28	115.41	115.41	0.00	0.08	0.21	0.21	0.00	0.00	0.01	0.01
PR-CB23	114.00	115.20	115.40	0.20	114.44	115.28	115.41	115.43	0.00	0.08	0.21	0.23	0.00	0.00	0.01	0.03
PR-CB24	113.95	115.55	115.85	0.30	115.46	115.66	115.78	115.82	0.00	0.11	0.23	0.27	0.00	0.00	0.00	0.00
PR-CB25	114.14	115.55	115.84	0.29	115.46	115.66	115.78	115.82	0.00	0.11	0.23	0.27	0.00	0.00	0.00	0.00
PR-CB26	114.35	115.55	115.85	0.30	115.46	115.66	115.78	115.82	0.00	0.11	0.23	0.27	0.00	0.00	0.00	0.00
PR-CB27	114.51	115.90	116.20	0.30	115.38	115.98	116.09	116.13	0.00	0.08	0.19	0.23	0.00	0.00	0.00	0.00
PR-CB28	114.70	115.90	116.20	0.30	115.38	115.99	116.09	116.13	0.00	0.09	0.19	0.23	0.00	0.00	0.00	0.00
PR-CB29	111.10	112.70	112.95	0.25	111.52	111.60	111.84	112.95	0.00	0.00	0.00	0.25	0.00	0.00	0.00	0.00
PR-CB30	111.40	112.40	112.65	0.25	111.51	112.38	112.64	112.67	0.00	0.00	0.24	0.27	0.00	0.00	0.00	0.02
PR-CB31	111.20	112.40	112.65	0.25	111.48	112.38	112.64	112.67	0.00	0.00	0.24	0.27	0.00	0.00	0.00	0.02
PR-CB32	110.65	112.90	113.00	0.10	111.18	111.30	113.01	113.05	0.00	0.00	0.11	0.15	0.00	0.00	0.01	0.05
PR-CB35	112.20	113.50	113.75	0.25	112.52	113.16	113.71	113.74	0.00	0.00	0.21	0.24	0.00	0.00	0.00	0.00
PR-CB36	111.85	113.45	113.66	0.21	112.48	112.82	113.59	113.68	0.00	0.00	0.14	0.23	0.00	0.00	0.00	0.02
PR-CB37	112.45	113.45	113.60	0.15	112.93	113.48	113.67	113.81	0.00	0.03	0.22	0.36	0.00	0.00	0.07	0.21

4837 Albion Road - Hard Rock Ottawa (116111)  
 PCSWMM Model Results - Proposed Conditions (Ponding)



CB / CBMH ID	Invert Elev. (m)	Rim Elev. (m)	Spill Elev. (m)	Ponding Depth (m)	HGL Elev. (m) <sup>1</sup>				Ponding Depth (m)				Spill Depth (m)			
					2-yr	5-yr	100-yr	100-yr (+20%)	2-yr	5-yr	100-yr	100-yr (+20%)	2-yr	5-yr	100-yr	100-yr (+20%)
PR-CB38	112.48	113.45	113.65	0.20	112.93	113.48	113.63	113.72	0.00	0.03	0.18	0.27	0.00	0.00	0.00	0.07
PR-CB39	112.65	113.80	113.80	0.00	112.93	113.48	113.63	113.72	0.00	0.00	0.00	0.00	0.00	0.00	0.00	0.00
PR-CB40	111.50	113.00	113.25	0.25	112.79	113.12	113.23	113.26	0.00	0.12	0.23	0.26	0.00	0.00	0.00	0.01
PR-CB41	111.30	112.70	113.35	0.65	112.09	112.61	112.77	112.79	0.00	0.00	0.07	0.09	0.00	0.00	0.00	0.00
PR-CBMH104	112.04	113.50	113.75	0.25	113.30	113.53	113.61	113.64	0.00	0.03	0.11	0.14	0.00	0.00	0.00	0.00
PR-CBMH105	111.85	113.45	113.65	0.20	112.92	113.48	113.63	113.72	0.00	0.03	0.18	0.27	0.00	0.00	0.00	0.07
PR-CBMH106	112.01	113.50	113.80	0.30	113.28	113.55	113.66	113.69	0.00	0.05	0.16	0.19	0.00	0.00	0.00	0.00
PR-CBMH107	111.84	113.40	113.70	0.30	112.52	113.16	113.70	113.72	0.00	0.00	0.30	0.32	0.00	0.00	0.00	0.02
PR-CBMH108	112.01	113.60	113.85	0.25	113.57	113.66	113.75	113.78	0.00	0.06	0.15	0.18	0.00	0.00	0.00	0.00
PR-CBMH109	111.96	113.60	113.90	0.30	113.60	113.70	113.81	113.85	0.00	0.10	0.21	0.25	0.00	0.00	0.00	0.00
PR-CBMH110	111.62	113.40	113.60	0.20	112.25	112.38	113.66	113.69	0.00	0.00	0.26	0.29	0.00	0.00	0.06	0.09
PR-CBMH111	113.00	115.05	115.40	0.35	113.55	113.66	115.20	115.21	0.00	0.00	0.15	0.16	0.00	0.00	0.00	0.00
PR-CBMH112	113.12	115.20	115.40	0.20	113.87	115.27	115.40	115.41	0.00	0.07	0.20	0.21	0.00	0.00	0.00	0.01
PR-CBMH114	113.51	115.55	115.85	0.30	115.45	115.65	115.78	115.82	0.00	0.10	0.23	0.27	0.00	0.00	0.00	0.00
PR-CBMH115	113.89	115.90	116.20	0.30	115.37	115.98	116.08	116.12	0.00	0.08	0.18	0.22	0.00	0.00	0.00	0.00
PR-CBMH118	110.74	112.40	112.65	0.25	111.43	112.35	112.63	112.68	0.00	0.00	0.23	0.28	0.00	0.00	0.00	0.03
PR-CBMH122	112.35	113.40	113.65	0.25	112.93	113.48	113.63	113.72	0.00	0.08	0.23	0.32	0.00	0.00	0.00	0.07
PR-TD02	111.65	112.70	113.30	0.60	112.28	112.71	112.78	112.81	0.00	0.01	0.08	0.11	0.00	0.00	0.00	0.00
PR-TD1	111.90	112.70	113.50	0.80	112.35	112.36	112.67	112.75	0.00	0.00	0.00	0.05	0.00	0.00	0.00	0.00

<sup>1</sup> 3-hour Chicago Storm.

MH ID	Obvert Elevation (m)	T/G Elevation (m)	HGL Elevation <sup>1</sup> (m)	Surcharge (m)	Clearance from T/G (m)	HGL in Stress Test <sup>1</sup> (m)
EX-MH101	105.32	106.91	105.04	0.00	1.87	105.06
EX-MH101A	107.93	112.19	107.66	0.00	4.53	107.66
EX-MH101B	106.08	110.41	105.74	0.00	4.67	105.74
EX-MH102	110.13	114.07	109.82	0.00	4.25	109.83
EX-MH102A	112.72	114.25	112.61	0.00	1.64	112.61
EX-MH103	111.01	113.00	110.78	0.00	2.22	110.78
EX-MH104	111.25	113.90	111.65	0.40	2.25	111.69
EX-MH105	111.28	114.02	113.67	2.39	0.35	113.71
EX-MH106	112.60	114.99	113.72	1.12	1.27	113.76
EX-MH107	112.65	114.95	113.85	1.20	1.10	113.89
EX-MH108	111.70	113.67	113.03	1.34	0.64	113.12
EX-MH109	111.58	113.61	112.51	0.93	1.10	112.59
EX-MH112	112.15	114.94	113.65	1.50	1.29	113.69
EX-MH115	105.35	106.87	106.03	0.68	0.84	106.04
EX-MH116	107.87	107.87	106.90	0.00	0.97	106.90
PR-MH100	112.16	113.66	113.58	1.42	0.08	113.62
PR-MH101	112.41	113.72	112.69	0.28	1.03	112.76
PR-MH102	112.23	113.97	112.67	0.44	1.30	112.75
PR-MH103	111.88	113.81	112.64	0.76	1.17	112.72
PR-MH113	113.56	115.28	113.39	0.00	1.89	113.39
PR-MH116	110.90	113.20	111.37	0.47	1.83	111.48
PR-MH117	111.21	112.82	111.86	0.65	0.96	111.99
PR-MH119	113.28	115.24	113.15	0.00	2.09	113.15
PR-MH120	113.98	115.58	113.78	0.00	1.80	113.78

<sup>1</sup> 3-hour Chicago Storm.

4837 Albion Road - Hard Rock Ottawa (116111)  
 PCSWMM Model Results - Proposed Conditions (Historical Storms)



**Max Computed Hydraulic Grade Line Elevations (m)**

MH ID	T/G Elevation	100-year (+20%) Design Storms		Historical Storms		
		3-hour Chicago	12-hour SCS	July 1, 1979	August 4, 1988	August 8, 1996
EX-CB72	112.67	112.94	112.80	112.77	112.79	112.73
EX-CB116	113.50	113.59	113.58	113.58	113.56	113.45
EX-CB117	113.35	113.59	113.58	113.58	113.56	113.44
EX-CB64	113.50	113.68	113.67	113.68	113.68	113.61
PR-CBMH110	113.40	113.69	113.67	113.68	113.68	113.59
PR-CB13	113.65	113.74	113.73	113.73	113.73	113.69
PR-CB14	113.55	113.68	113.68	113.68	113.66	112.50
PR-CB15	113.40	113.68	113.68	113.68	113.66	113.59
PR-CB35	113.50	113.74	113.73	113.74	113.76	113.25
PR-CBMH107	113.40	113.72	113.74	113.72	113.73	113.25
PR-CBMH105	113.45	113.72	113.73	113.72	113.74	113.54
PR-CB32	112.90	113.05	113.02	113.02	113.03	112.95
EX-CB134	113.30	113.41	113.06	113.30	113.41	113.32

\*Lowest building opening (finished floor elevation) = 114.00 m.

4837 Albion Road - Hard Rock Ottawa (116111)  
 PCSWMM Model Output - Pr. Conditions (100-year, 3-hour Chicago Storm)

EPA STORM WATER MANAGEMENT MODEL - VERSION 5.1 (Build 5.1.015)

\*\*\*\*\*  
 Element Count

\*\*\*\*\*  
 Number of rain gages ..... 1  
 Number of subcatchments ... 80  
 Number of nodes ..... 239  
 Number of links ..... 314  
 Number of pollutants ..... 0  
 Number of land uses ..... 0

\*\*\*\*\*  
 Raingage Summary

\*\*\*\*\*  

Name	Data Source	Data Type	Recording Interval
Design_Storms	C3hr-100yr	INTENSITY	10 min.

\*\*\*\*\*  
 Subcatchment Summary

\*\*\*\*\*  

Name	Area	Width	%Imperv	%Slope	Rain Gage	Outlet
A-01	0.23	74.56	100.00	1.5000	Design_Storms	PR-CB26
A-02	0.21	66.18	100.00	1.5000	Design_Storms	PR-CB23
A-03	0.08	58.88	100.00	1.5000	Design_Storms	PR-CB20
A-04a	0.34	48.75	82.90	1.5000	Design_Storms	EX-CB14
A-04b	0.76	105.17	85.70	1.5000	Design_Storms	EX-CB14
A-05	0.07	46.07	85.70	1.5000	Design_Storms	PR-CB19
A-06	0.16	47.81	100.00	1.5000	Design_Storms	PR-CB22
A-07	0.18	57.59	100.00	1.5000	Design_Storms	PR-CB25
A-08	0.15	52.13	100.00	1.5000	Design_Storms	PR-CB28
A-09	0.16	53.70	100.00	1.5000	Design_Storms	PR-CB27
A-10	0.18	54.98	100.00	1.5000	Design_Storms	PR-CB24

A-11	0.17	48.08	100.00	1.5000	Design_Storms	PR-CB21
A-12	0.07	42.88	85.70	1.5000	Design_Storms	PR-CBMH111
A-13	0.06	31.74	82.90	1.5000	Design_Storms	PR-CB18
A-14	0.17	49.42	100.00	1.5000	Design_Storms	PR-CBMH112
A-15	0.21	71.14	100.00	1.5000	Design_Storms	PR-CBMH114
A-16	0.15	53.10	100.00	1.5000	Design_Storms	PR-CBMH115
A-17a	0.26	68.20	60.00	1.5000	Design_Storms	EX-CB87
A-17b	0.15	87.40	95.70	1.5000	Design_Storms	EX-CB90
A-17c	0.29	68.85	70.00	1.5000	Design_Storms	EX-CB92
A-17d	0.19	105.36	98.60	1.5000	Design_Storms	EX-CB96
A-17e	0.36	86.02	60.00	1.5000	Design_Storms	EX-CB30
A-17f	0.23	124.94	94.30	1.5000	Design_Storms	EX-CB28
A-18	0.50	137.27	67.10	1.5000	Design_Storms	PR-CB16/17
A-19a	0.10	51.50	67.10	1.5000	Design_Storms	EX-MH104
A-19b	0.17	69.60	67.10	1.5000	Design_Storms	EX-CB137
A-20	0.40	117.54	95.70	1.5000	Design_Storms	EX-CB82
A-21	0.17	80.22	95.70	1.5000	Design_Storms	EX-CB84
A-22	0.78	155.60	0.00	1.5000	Design_Storms	EX-MH101
A-23	0.05	30.23	77.10	1.5000	Design_Storms	EX-CB72
A-24	0.06	27.65	72.90	1.5000	Design_Storms	EX-MH108
A-25	0.09	10.13	64.30	1.5000	Design_Storms	EX-CB95
A-26	0.10	12.04	52.90	1.5000	Design_Storms	EX-CB128
A-27	0.10	10.85	51.40	1.5000	Design_Storms	EX-CB62
A-28	0.12	14.46	85.70	1.5000	Design_Storms	EX-CB60
A-29	0.11	31.07	64.30	1.5000	Design_Storms	EX-CB117
A-30	0.86	66.50	100.00	1.5000	Design_Storms	EX-BLDG01
A-31	0.05	24.67	100.00	1.5000	Design_Storms	EX-CB116
A-32	0.08	55.19	80.00	1.5000	Design_Storms	EX-CB64
A-33	0.24	58.64	77.10	1.5000	Design_Storms	PR-CBMH110
A-34a	0.15	64.82	98.60	1.5000	Design_Storms	EX-CB58
A-34b	0.25	108.53	100.00	1.5000	Design_Storms	EX-CB50
A-34c	0.20	83.67	95.70	1.5000	Design_Storms	EX-CB52
A-35	0.12	53.74	88.60	1.5000	Design_Storms	PR-CB15
A-36	0.05	49.09	100.00	1.5000	Design_Storms	PR-CB13
A-37	0.06	22.59	44.30	1.5000	Design_Storms	PR-CB14
A38a-1	0.98	85.11	100.00	1.5000	Design_Storms	PR-BLDG01
A38a-2	0.40	53.03	100.00	1.5000	Design_Storms	PR-BLDG02
A-39	0.07	43.48	100.00	1.5000	Design_Storms	EX-CB134
A-40	0.15	45.23	100.00	1.5000	Design_Storms	PR-CB32
A-41	0.28	48.64	100.00	1.5000	Design_Storms	PR-CBMH118
A-42	0.20	41.44	100.00	1.5000	Design_Storms	PR-CB31



4837 Albion Road - Hard Rock Ottawa (116111)  
 PCSWMM Model Output - Pr. Conditions (100-year, 3-hour Chicago Storm)

A-43	0.12	44.15	100.00	1.5000	Design_Storms	PR-CB29
A-44	0.09	41.65	100.00	1.5000	Design_Storms	PR-CB30
A-45	0.14	57.38	92.90	1.5000	Design_Storms	PR-CB40
A-45a	0.03	19.81	100.00	1.5000	Design_Storms	PR-CB41
A-46	0.12	34.11	100.00	1.5000	Design_Storms	PR-TD02
A-47	0.08	33.89	50.00	1.5000	Design_Storms	PR-CB01
A-48	0.04	48.76	87.10	1.5000	Design_Storms	PR-CB02
A-49	0.08	48.99	40.00	1.5000	Design_Storms	PR-CB03
A-50	0.06	28.26	57.10	1.5000	Design_Storms	PR-CB36
A-51	0.09	69.83	98.60	1.5000	Design_Storms	PR-CB04
A-52	0.05	25.82	81.40	1.5000	Design_Storms	PR-CB38
A-52a	0.01	15.62	100.00	1.5000	Design_Storms	PR-CB39
A-53	0.09	44.37	72.90	1.5000	Design_Storms	PR-CBMH122
A-54	0.04	23.42	71.40	1.5000	Design_Storms	PR-CBMH105
A-55	0.06	49.14	80.00	1.5000	Design_Storms	PR-CBMH104
A-56	0.08	46.12	100.00	1.5000	Design_Storms	PR-CB05
A-57	0.03	28.53	97.10	1.5000	Design_Storms	PR-CB37
A-58	0.04	26.84	68.60	2.0000	Design_Storms	PR-CB35
A-60	0.12	62.67	97.10	1.5000	Design_Storms	PR-CBMH106
A-61	0.10	78.95	100.00	1.5000	Design_Storms	PR-CB08
A-62	0.11	64.05	100.00	1.5000	Design_Storms	PR-CB09
A-63	0.13	72.43	100.00	1.5000	Design_Storms	PR-CBMH108
A-65	0.22	103.25	100.00	1.5000	Design_Storms	PR-CBMH109
A-66	0.20	110.84	100.00	1.5000	Design_Storms	PR-CB12
A-67	0.15	98.70	100.00	1.5000	Design_Storms	PR-CB11
A-68	0.11	42.02	62.90	1.5000	Design_Storms	EX-CB54
A-69	0.14	59.31	74.30	1.5000	Design_Storms	PR-CBMH107
A-70	0.02	31.75	100.00	4.0000	Design_Storms	PR-TD1

\*\*\*\*\*  
 Node Summary  
 \*\*\*\*\*

Name	Type	Invert Elev.	Max. Depth	Ponded Area	External Inflow
HP-01	JUNCTION	114.10	1.00	0.0	
HP-EX-CB116	JUNCTION	113.60	1.00	0.0	
HP-EX-CB117	JUNCTION	113.56	1.00	0.0	
HP-EX-CB128a	JUNCTION	113.90	1.00	0.0	
HP-EX-CB128b	JUNCTION	113.95	1.00	0.0	

HP-EX-CB131	JUNCTION	112.90	1.00	0.0	
HP-EX-CB134	JUNCTION	113.40	1.00	0.0	
HP-EX-CB137	JUNCTION	113.60	1.00	0.0	
HP-EX-CB28	JUNCTION	114.00	1.00	0.0	
HP-EX-CB30a	JUNCTION	114.00	1.00	0.0	
HP-EX-CB30b	JUNCTION	114.00	1.00	0.0	
HP-EX-CB50a	JUNCTION	114.00	1.00	0.0	
HP-EX-CB50b	JUNCTION	114.00	1.00	0.0	
HP-EX-CB52	JUNCTION	113.98	1.00	0.0	
HP-EX-CB54	JUNCTION	114.00	1.00	0.0	
HP-EX-CB58a	JUNCTION	114.00	1.00	0.0	
HP-EX-CB58b	JUNCTION	114.00	1.00	0.0	
HP-EX-CB60	JUNCTION	113.90	1.00	0.0	
HP-EX-CB62	JUNCTION	113.90	1.00	0.0	
HP-EX-CB64	JUNCTION	113.65	1.00	0.0	
HP-EX-CB72	JUNCTION	113.00	1.00	0.0	
HP-EX-CB82	JUNCTION	114.05	1.00	0.0	
HP-EX-CB84	JUNCTION	114.00	1.00	0.0	
HP-EX-CB87a	JUNCTION	113.95	1.00	0.0	
HP-EX-CB87b	JUNCTION	113.95	1.00	0.0	
HP-EX-CB90	JUNCTION	113.95	1.00	0.0	
HP-EX-CB92	JUNCTION	113.95	1.00	0.0	
HP-EX-CB95	JUNCTION	113.95	1.00	0.0	
HP-EX-CB96	JUNCTION	113.95	1.00	0.0	
HP-PR-CB01	JUNCTION	113.60	1.00	0.0	
HP-PR-CB02	JUNCTION	113.64	1.00	0.0	
HP-PR-CB03	JUNCTION	113.64	1.00	0.0	
HP-PR-CB04	JUNCTION	113.65	1.00	0.0	
HP-PR-CB05	JUNCTION	113.70	1.00	0.0	
HP-PR-CB06	JUNCTION	113.65	1.00	0.0	
HP-PR-CB07	JUNCTION	113.65	1.00	0.0	
HP-PR-CB08	JUNCTION	113.75	1.00	0.0	
HP-PR-CB09	JUNCTION	113.85	1.00	0.0	
HP-PR-CB12	JUNCTION	113.87	1.00	0.0	
HP-PR-CB13	JUNCTION	113.72	1.00	0.0	
HP-PR-CB14	JUNCTION	113.65	1.00	0.0	
HP-PR-CB15	JUNCTION	113.67	1.00	0.0	
HP-PR-CB16/17	JUNCTION	113.65	1.00	0.0	
HP-PR-CB18	JUNCTION	115.20	1.00	0.0	
HP-PR-CB19	JUNCTION	115.20	1.00	0.0	
HP-PR-CB20	JUNCTION	115.20	1.00	0.0	

4837 Albion Road - Hard Rock Ottawa (116111)  
 PCSWMM Model Output - Pr. Conditions (100-year, 3-hour Chicago Storm)

HP-PR-CB21	JUNCTION	115.40	1.00	0.0
HP-PR-CB22	JUNCTION	115.40	1.00	0.0
HP-PR-CB23	JUNCTION	115.40	1.00	0.0
HP-PR-CB24a	JUNCTION	115.85	1.00	0.0
HP-PR-CB24b	JUNCTION	115.85	1.00	0.0
HP-PR-CB25a	JUNCTION	115.85	1.00	0.0
HP-PR-CB25b	JUNCTION	115.85	1.00	0.0
HP-PR-CB26a	JUNCTION	115.85	1.00	0.0
HP-PR-CB26b	JUNCTION	115.85	1.00	0.0
HP-PR-CB27a	JUNCTION	116.20	1.00	0.0
HP-PR-CB27b	JUNCTION	116.20	1.00	0.0
HP-PR-CB28a	JUNCTION	116.20	1.00	0.0
HP-PR-CB28b	JUNCTION	116.20	1.00	0.0
HP-PR-CB29	JUNCTION	112.95	1.00	0.0
HP-PR-CB34	JUNCTION	113.75	1.00	0.0
HP-PR-CB35	JUNCTION	113.75	1.00	0.0
HP-PR-CB36	JUNCTION	113.66	1.00	0.0
HP-PR-CB40	JUNCTION	113.25	1.00	0.0
HP-PR-CBMH104	JUNCTION	113.75	1.00	0.0
HP-PR-CBMH105	JUNCTION	113.70	1.00	0.0
HP-PR-CBMH106	JUNCTION	113.80	1.00	0.0
HP-PR-CBMH107	JUNCTION	113.70	1.00	0.0
HP-PR-CBMH108a	JUNCTION	113.85	1.00	0.0
HP-PR-CBMH108b	JUNCTION	113.85	1.00	0.0
HP-PR-CBMH109	JUNCTION	113.90	1.00	0.0
HP-PR-CBMH110	JUNCTION	113.60	1.00	0.0
HP-PR-CBMH111	JUNCTION	115.20	1.00	0.0
HP-PR-CBMH112	JUNCTION	115.40	1.00	0.0
HP-PR-CBMH114	JUNCTION	115.85	1.00	0.0
HP-PR-CBMH115	JUNCTION	116.20	1.00	0.0
HP-PR-CBMH124	JUNCTION	113.35	1.00	0.0
HP-PR-TD02	JUNCTION	113.30	1.00	0.0
HP-EX-CB14	OUTFALL	114.10	1.00	0.0
HP-EX-MH116	OUTFALL	106.84	1.00	0.0
HP-PR-CB11	OUTFALL	113.85	1.00	0.0
HP-PR-CB30	OUTFALL	112.65	1.00	0.0
HP-PR-CB31	OUTFALL	112.65	1.00	0.0
HP-PR-CB32	OUTFALL	113.00	1.00	0.0
HP-PR-CBMH118	OUTFALL	112.65	1.00	0.0
IF-EX-CB116	OUTFALL	112.99	0.00	0.0
IF-EX-CB117	OUTFALL	112.09	0.00	0.0

IF-EX-CB128	OUTFALL	112.51	0.00	0.0
IF-EX-CB137	OUTFALL	112.00	0.00	0.0
IF-EX-CB14	OUTFALL	111.19	0.00	0.0
IF-EX-CB28	OUTFALL	112.43	0.00	0.0
IF-EX-CB30	OUTFALL	112.50	0.00	0.0
IF-EX-CB50	OUTFALL	112.34	0.00	0.0
IF-EX-CB52	OUTFALL	112.44	0.00	0.0
IF-EX-CB54	OUTFALL	112.52	0.00	0.0
IF-EX-CB58	OUTFALL	112.44	0.00	0.0
IF-EX-CB64	OUTFALL	112.10	0.00	0.0
IF-EX-CB82	OUTFALL	112.62	0.00	0.0
IF-EX-CB84	OUTFALL	112.12	0.00	0.0
IF-EX-CB87	OUTFALL	112.50	0.00	0.0
IF-EX-CB90	OUTFALL	112.51	0.00	0.0
IF-EX-CB92	OUTFALL	112.49	0.00	0.0
IF-EX-CB95	OUTFALL	112.45	0.00	0.0
IF-EX-CB96	OUTFALL	112.22	0.00	0.0
IF-PR-CB04	OUTFALL	111.80	0.00	0.0
IF-PR-CB13	OUTFALL	111.90	0.00	0.0
IF-PR-CB14	OUTFALL	111.80	0.00	0.0
IF-PR-CB18	OUTFALL	113.49	0.00	0.0
IF-PR-CB29	OUTFALL	111.10	0.00	0.0
IF-PR-CB32	OUTFALL	110.65	0.00	0.0
IF-PR-CB36	OUTFALL	111.85	0.00	0.0
IF-PR-CB40	OUTFALL	111.50	0.00	0.0
IF-PR-CBMH104	OUTFALL	112.04	0.00	0.0
IF-PR-CBMH105	OUTFALL	111.85	0.00	0.0
IF-PR-CBMH106	OUTFALL	112.01	0.00	0.0
IF-PR-CBMH107	OUTFALL	111.84	0.00	0.0
IF-PR-CBMH108	OUTFALL	112.01	0.00	0.0
IF-PR-CBMH109	OUTFALL	111.96	0.00	0.0
IF-PR-CBMH110	OUTFALL	111.62	0.00	0.0
IF-PR-CBMH111	OUTFALL	113.00	0.00	0.0
IF-PR-CBMH112	OUTFALL	113.12	0.00	0.0
IF-PR-CBMH114	OUTFALL	113.51	0.00	0.0
IF-PR-CBMH115	OUTFALL	113.89	0.00	0.0
IF-PR-CBMH118	OUTFALL	110.74	0.00	0.0
Major-01	OUTFALL	112.87	1.00	0.0
SWM_Pond	OUTFALL	102.95	0.75	0.0
EX-BLDG01	STORAGE	120.00	1.00	0.0
EX-CB116	STORAGE	112.99	1.51	0.0

4837 Albion Road - Hard Rock Ottawa (116111)  
 PCSWMM Model Output - Pr. Conditions (100-year, 3-hour Chicago Storm)

EX-CB117	STORAGE	112.09	2.26	0.0
EX-CB128	STORAGE	112.51	2.20	0.0
EX-CB134	STORAGE	111.60	2.70	0.0
EX-CB137	STORAGE	112.00	2.40	0.0
EX-CB14	STORAGE	111.19	3.21	0.0
EX-CB28	STORAGE	112.43	2.22	0.0
EX-CB30	STORAGE	112.50	2.20	0.0
EX-CB50	STORAGE	112.34	2.37	0.0
EX-CB52	STORAGE	112.44	2.27	0.0
EX-CB54	STORAGE	112.52	2.31	0.0
EX-CB58	STORAGE	112.44	2.29	0.0
EX-CB60	STORAGE	112.15	2.58	0.0
EX-CB62	STORAGE	112.64	2.12	0.0
EX-CB64	STORAGE	112.10	2.40	0.0
EX-CB72	STORAGE	111.18	2.49	0.0
EX-CB82	STORAGE	112.62	2.22	0.0
EX-CB84	STORAGE	112.12	2.53	0.0
EX-CB87	STORAGE	112.50	2.18	0.0
EX-CB90	STORAGE	112.51	2.29	0.0
EX-CB92	STORAGE	112.49	2.18	0.0
EX-CB95	STORAGE	112.45	2.22	0.0
EX-CB96	STORAGE	112.22	2.40	0.0
EX-MH101	STORAGE	104.57	2.34	0.0
EX-MH101A	STORAGE	107.18	5.01	0.0
EX-MH101B	STORAGE	105.33	5.08	0.0
EX-MH102	STORAGE	109.38	4.69	0.0
EX-MH102A	STORAGE	112.33	1.92	0.0
EX-MH103	STORAGE	110.71	2.29	0.0
EX-MH104	STORAGE	110.65	3.25	0.0
EX-MH105	STORAGE	111.28	2.74	0.0
EX-MH105a	STORAGE	111.28	2.74	0.0
EX-MH106	STORAGE	112.15	2.84	0.0
EX-MH106a	STORAGE	111.61	2.39	0.0
EX-MH107	STORAGE	112.35	2.60	0.0
EX-MH107a	STORAGE	112.20	2.78	0.0
EX-MH108	STORAGE	111.32	2.35	0.0
EX-MH109	STORAGE	110.98	2.63	0.0
EX-MH112	STORAGE	112.15	2.79	0.0
EX-MH112a	STORAGE	112.15	1.79	0.0
EX-MH115	STORAGE	105.05	1.82	0.0
EX-MH116	STORAGE	105.50	2.37	0.0

EX-STUB02	STORAGE	111.38	2.28	0.0
PR-BLDG01	STORAGE	120.00	1.00	0.0
PR-BLDG02	STORAGE	120.00	1.00	0.0
PR-CB01	STORAGE	112.40	2.00	0.0
PR-CB02	STORAGE	112.45	1.95	0.0
PR-CB02a	STORAGE	112.36	2.15	0.0
PR-CB03	STORAGE	112.40	2.00	0.0
PR-CB04	STORAGE	111.80	2.60	0.0
PR-CB05	STORAGE	112.45	2.00	0.0
PR-CB08	STORAGE	112.45	2.05	0.0
PR-CB09	STORAGE	112.45	2.15	0.0
PR-CB11	STORAGE	112.60	2.00	0.0
PR-CB12	STORAGE	112.42	2.18	0.0
PR-CB13	STORAGE	111.90	2.75	0.0
PR-CB14	STORAGE	111.80	2.75	0.0
PR-CB15	STORAGE	112.20	2.20	0.0
PR-CB16/17	STORAGE	112.09	2.26	0.0
PR-CB18	STORAGE	113.49	2.56	0.0
PR-CB19	STORAGE	113.65	2.40	0.0
PR-CB20	STORAGE	113.85	2.20	0.0
PR-CB21	STORAGE	113.56	2.64	0.0
PR-CB22	STORAGE	113.80	2.40	0.0
PR-CB23	STORAGE	114.00	2.20	0.0
PR-CB24	STORAGE	113.95	2.60	0.0
PR-CB25	STORAGE	114.14	2.41	0.0
PR-CB26	STORAGE	114.35	2.20	0.0
PR-CB27	STORAGE	114.51	2.39	0.0
PR-CB28	STORAGE	114.70	2.20	0.0
PR-CB29	STORAGE	111.10	2.60	0.0
PR-CB30	STORAGE	111.40	2.00	0.0
PR-CB31	STORAGE	111.20	2.20	0.0
PR-CB32	STORAGE	110.65	3.25	0.0
PR-CB35	STORAGE	112.20	2.30	0.0
PR-CB36	STORAGE	111.85	2.60	0.0
PR-CB37	STORAGE	112.45	2.00	0.0
PR-CB38	STORAGE	112.48	1.97	0.0
PR-CB39	STORAGE	112.65	2.15	0.0
PR-CB40	STORAGE	111.50	2.50	0.0
PR-CB41	STORAGE	111.30	2.40	0.0
PR-CBMH104	STORAGE	112.04	2.46	0.0
PR-CBMH105	STORAGE	111.85	2.60	0.0

4837 Albion Road - Hard Rock Ottawa (116111)  
 PCSWMM Model Output - Pr. Conditions (100-year, 3-hour Chicago Storm)

PR-CBMH106	STORAGE	112.01	2.49	0.0
PR-CBMH107	STORAGE	111.84	2.56	0.0
PR-CBMH108	STORAGE	112.01	2.59	0.0
PR-CBMH109	STORAGE	111.96	2.64	0.0
PR-CBMH109a	STORAGE	112.21	2.39	0.0
PR-CBMH110	STORAGE	111.62	2.78	0.0
PR-CBMH111	STORAGE	113.00	3.05	0.0
PR-CBMH112	STORAGE	113.12	3.08	0.0
PR-CBMH114	STORAGE	113.51	3.04	0.0
PR-CBMH115	STORAGE	113.89	3.01	0.0
PR-CBMH115a	STORAGE	114.14	2.76	0.0
PR-CBMH118	STORAGE	110.74	2.66	0.0
PR-CBMH122	STORAGE	112.35	2.05	0.0
PR-MH100	STORAGE	112.16	1.50	0.0
PR-MH100a	STORAGE	112.16	1.50	0.0
PR-MH101	STORAGE	111.96	1.76	0.0
PR-MH102	STORAGE	111.70	2.27	0.0
PR-MH103	STORAGE	111.28	2.53	0.0
PR-MH104	STORAGE	111.10	2.59	0.0
PR-MH113	STORAGE	113.26	2.02	0.0
PR-MH116	STORAGE	110.65	2.55	0.0
PR-MH117	STORAGE	110.91	1.91	0.0
PR-MH119	STORAGE	112.98	2.26	0.0
PR-MH120	STORAGE	113.68	1.90	0.0
PR-MH123	STORAGE	111.12	1.94	0.0
PR-OGS1	STORAGE	111.38	1.90	0.0
PR-STUB01	STORAGE	111.26	8.74	0.0
PR-TD02	STORAGE	111.65	2.05	0.0
PR-TD1	STORAGE	111.90	1.80	0.0

\*\*\*\*\*  
 Link Summary  
 \*\*\*\*\*

Name	From Node	To Node	Type	Length	%Slope	Roughness
108_(CB)	PR-CB03	PR-MH100	CONDUIT	9.6	0.5208	0.0130
115_(CB)	PR-CB19	PR-CBMH111	CONDUIT	33.8	1.0060	0.0130
121_(CB)	PR-CB20	PR-CB19	CONDUIT	40.3	0.4963	0.0130
138_(CB)_1	PR-CB01	PR-CB02a	CONDUIT	14.5	0.3099	0.0130
138_(CB)_2	PR-CB02a	PR-MH100	CONDUIT	17.6	0.3125	0.0130

14_(STM)	EX-MH112a	PR-MH103	CONDUIT	45.5	0.1978	0.0130
142_(STM)	PR-CB04	PR-MH100	CONDUIT	13.9	0.3597	0.0130
145_(CB)	PR-CB09	PR-CBMH108	CONDUIT	36.8	0.4891	0.0130
150_(1_(STM))	PR-MH123	PR-MH117	CONDUIT	36.2	0.4972	0.0130
156_(STM)	PR-CB02	PR-CB02a	CONDUIT	13.4	0.5220	0.0130
163_(STM)	PR-CB30	PR-CB31	CONDUIT	36.1	0.5263	0.0130
165_(CB)	PR-CB31	PR-CBMH118	CONDUIT	29.3	0.5120	0.0130
17_(1_(STM))	PR-MH117	PR-MH116	CONDUIT	49.7	0.5028	0.0130
20_(STM)	PR-STUB01	PR-MH116	CONDUIT	30.0	2.0004	0.0130
226_(CB)	PR-TD1	PR-MH102	CONDUIT	17.5	0.5143	0.0130
230_(CB)	PR-CB35	PR-CBMH107	CONDUIT	21.5	0.5116	0.0130
246_(CB)	PR-CBMH122	PR-CBMH105	CONDUIT	22.4	0.4920	0.0130
250_(CB)	PR-CB37	PR-CBMH122	CONDUIT	18.9	0.4772	0.0130
251_(CB)	PR-CB38	PR-CBMH122	CONDUIT	23.7	0.5072	0.0130
268_(STM)	PR-OGS1	PR-MH123	CONDUIT	49.4	0.5061	0.0130
271_(CB)	PR-CB39	PR-CB38	CONDUIT	27.1	0.5170	0.0130
28_(1_(STM))	PR-MH113	PR-MH119	CONDUIT	27.4	0.9854	0.0130
28_(STM)	PR-MH119	EX-MH102A	CONDUIT	58.8	1.0035	0.0130
30_(STM)	PR-MH120	PR-MH113	CONDUIT	51.1	0.8024	0.0130
32_(STM)	PR-CBMH115a	PR-MH120	CONDUIT	44.7	1.0068	0.0130
34_(1_(STM))	PR-CB28	PR-CB27	CONDUIT	36.8	0.4891	0.0130
34_(STM)	PR-CB27	PR-CBMH115	CONDUIT	36.8	0.8424	0.0130
36_(1_(STM))	PR-CB25	PR-CB24	CONDUIT	36.8	0.4891	0.0130
36_(STM)	PR-CB24	PR-CBMH114	CONDUIT	36.8	0.4891	0.0130
42_(1_(STM))	PR-CB23	PR-CB22	CONDUIT	36.8	0.5163	0.0130
42_(2_(STM))	PR-CB22	PR-CB21	CONDUIT	36.8	0.4891	0.0130
49_(STM)	PR-CB26	PR-CB25	CONDUIT	37.1	0.4852	0.0130
5_(STM)_1	PR-MH100a	PR-MH101	CONDUIT	61.3	0.2936	0.0130
5_(STM)_2	PR-MH101	PR-MH102	CONDUIT	61.6	0.2922	0.0130
54_(STM)	PR-CB21	PR-CBMH112	CONDUIT	36.8	0.4891	0.0130
57_(STM)	PR-CBMH109a	PR-MH102	CONDUIT	42.5	0.4941	0.0130
59_(STM)	PR-CB12	PR-CBMH109	CONDUIT	36.7	0.4905	0.0130
61_(STM)	PR-CB11	PR-CB12	CONDUIT	33.7	0.5045	0.0130
64_(CB)	PR-CB15	PR-CBMH110	CONDUIT	29.9	1.0034	0.0130
7_(STM)	PR-MH102	PR-MH103	CONDUIT	106.0	0.2925	0.0130
86_(CB)	PR-CB08	PR-CBMH106	CONDUIT	36.8	0.4891	0.0130
9_(1_(STM))	PR-MH104	EX-MH109	CONDUIT	32.9	0.3040	0.0130
9_(STM)_2	PR-MH103	PR-MH104	CONDUIT	57.6	0.2951	0.0130
94_(CB)	PR-CB05	PR-CBMH104	CONDUIT	27.6	0.5073	0.0130
C1	EX-CB116	EX-CB117	CONDUIT	11.4	7.3001	0.0130
C10	PR-CB26	HP-PR-CB26a	CONDUIT	3.0	-10.0504	0.0150

4837 Albion Road - Hard Rock Ottawa (116111)  
 PCSWMM Model Output - Pr. Conditions (100-year, 3-hour Chicago Storm)

C100	EX-CB72	HP-EX-CB72	CONDUIT	3.0	-11.0672	0.0150
C101	EX-CB30	HP-EX-CB30b	CONDUIT	3.0	-10.0504	0.0150
C102	HP-EX-CB30b	EX-CB92	CONDUIT	3.0	11.0672	0.0150
C103	HP-EX-CB87a	EX-CB92	CONDUIT	3.0	9.3743	0.0150
C104	EX-CB87	HP-EX-CB87a	CONDUIT	3.0	-9.0367	0.0150
C105	EX-CB30	HP-EX-CB30a	CONDUIT	3.0	-10.0504	0.0150
C106	HP-EX-CB30a	EX-CB28	CONDUIT	3.0	11.7469	0.0150
C107	EX-CB28	HP-EX-CB28	CONDUIT	3.0	-11.7469	0.0150
C108	HP-EX-CB28	EX-CB96	CONDUIT	3.0	12.7695	0.0150
C109	HP-EX-CB90	EX-CB96	CONDUIT	3.0	11.0672	0.0150
C11	HP-PR-CB26a	PR-CB25	CONDUIT	3.0	10.0504	0.0150
C110	EX-CB90	HP-EX-CB90	CONDUIT	3.0	-5.0063	0.0150
C111	EX-CB92	HP-EX-CB92	CONDUIT	3.0	-9.3743	0.0150
C112	HP-EX-CB92	EX-CB96	CONDUIT	3.0	11.0672	0.0150
C113	HP-EX-CB87b	EX-CB90	CONDUIT	3.0	5.0063	0.0150
C114	EX-CB54	HP-EX-CB54	CONDUIT	3.0	-5.6758	0.0150
C115	HP-EX-CB54	EX-CB52	CONDUIT	3.0	9.7122	0.0150
C116	HP-EX-CB50a	EX-CB52	CONDUIT	3.0	9.7122	0.0150
C117	EX-CB50	HP-EX-CB50a	CONDUIT	3.0	-9.7122	0.0150
C118	HP-EX-CB58a	EX-CB50	CONDUIT	3.0	9.7122	0.0150
C119	EX-CB58	HP-EX-CB58a	CONDUIT	3.0	-9.0367	0.0150
C12	PR-CB25	HP-PR-CB25a	CONDUIT	3.0	-10.0504	0.0150
C120	EX-CB96	HP-EX-CB96	CONDUIT	3.0	-11.0672	0.0150
C121	HP-EX-CB96	EX-CB95	CONDUIT	3.0	9.3743	0.0150
C122	EX-CB95	HP-EX-CB95	CONDUIT	3.0	-9.3743	0.0150
C123	HP-EX-CB95	EX-CB128	CONDUIT	3.0	8.0257	0.0150
C124	EX-CB128	HP-EX-CB128a	CONDUIT	3.0	-6.3461	0.0150
C125	HP-EX-CB128a	EX-CB62	CONDUIT	3.0	4.6718	0.0150
C126	EX-CB52	HP-EX-CB52	CONDUIT	3.0	-9.0367	0.0150
C127	HP-EX-CB52	PR-CB13	CONDUIT	3.0	11.0672	0.0150
C128	PR-CB13	HP-PR-CB13	CONDUIT	3.0	-2.3340	0.0150
C129	HP-PR-CB13	PR-CB14	CONDUIT	3.0	5.6758	0.0150
C13	HP-PR-CB25a	PR-CB24	CONDUIT	3.0	10.0504	0.0150
C130	EX-CB50	HP-EX-CB50b	CONDUIT	3.0	-9.7122	0.0150
C131	HP-EX-CB50b	PR-CB15	CONDUIT	3.0	20.4124	0.0150
C132	EX-CB58	HP-EX-CB58b	CONDUIT	3.0	-9.0367	0.0150
C133	HP-EX-CB58b	EX-CB60	CONDUIT	3.0	9.0367	0.0150
C134	HP-EX-CB134	PR-CB32	CONDUIT	3.0	16.9031	0.0150
C135	HP-EX-CB137	HP-EX-CB131	CONDUIT	3.0	23.9957	0.0150
C136	HP-EX-CB72	HP-EX-CB131	CONDUIT	3.0	3.3352	0.0150
C137	HP-EX-CB131	Major-01	CONDUIT	3.0	1.0001	0.0150

C138	EX-CB128	HP-EX-CB128b	CONDUIT	3.0	-8.0257	0.0150
C139	HP-EX-CB128b	HP-PR-CB16/17	CONDUIT	3.0	10.0504	0.0150
C14	HP-PR-CB24a	PR-CBMH114	CONDUIT	3.0	10.0504	0.0150
C140	HP-PR-CB29	PR-CB31	CONDUIT	3.0	18.6494	0.0150
C141	HP-PR-CB01	PR-CB40	CONDUIT	3.0	20.4124	0.0150
C142	PR-CBMH107	HP-PR-CBMH107	CONDUIT	3.0	-8.3624	0.0150
C143	HP-PR-CBMH107	PR-CBMH105	CONDUIT	3.0	8.3624	0.0150
C144	HP-PR-CBMH105	PR-CB36	CONDUIT	3.0	8.3624	0.0150
C145	PR-CB36	HP-PR-CB36	CONDUIT	3.0	-7.0172	0.0150
C146	PR-TD1	HP-PR-CB34	CONDUIT	3.0	-8.3624	0.0150
C147	HP-PR-CB34	PR-CBMH107	CONDUIT	3.0	10.0504	0.0130
C148	PR-CB35	HP-PR-CB35	CONDUIT	3.0	-6.6815	0.0150
C149	HP-PR-CB35	PR-CBMH107	CONDUIT	3.0	10.0504	0.0150
C15	PR-CB24	HP-PR-CB24a	CONDUIT	3.0	-10.0504	0.0150
C150	EX-CB134	HP-EX-CB134	CONDUIT	3.0	-3.3352	0.0150
C151	PR-CB41	HP-PR-CBMH124	CONDUIT	3.0	-22.1939	0.0150
C152	HP-PR-CBMH124	PR-CB40	CONDUIT	3.0	11.7469	0.0150
C16	PR-CBMH115	HP-PR-CBMH115	CONDUIT	3.0	-10.0504	0.0150
C17	HP-PR-CBMH115	PR-CBMH114	CONDUIT	3.0	22.1939	0.0150
C18	PR-CB26	HP-PR-CB26b	CONDUIT	3.0	-10.0504	0.0150
C19	HP-PR-CB26b	PR-CB23	CONDUIT	3.0	22.1939	0.0150
C2	PR-CB28	HP-PR-CB28a	CONDUIT	3.0	-10.0504	0.0150
C20	HP-PR-CB25b	PR-CB22	CONDUIT	3.0	22.1939	0.0150
C21	HP-PR-CB24b	PR-CB21	CONDUIT	3.0	22.1939	0.0150
C22	HP-PR-CBMH114	PR-CBMH112	CONDUIT	3.0	22.1939	0.0150
C23	HP-PR-CB23	PR-CB20	CONDUIT	3.0	11.7469	0.0150
C24	HP-PR-CB22	PR-CB19	CONDUIT	3.0	11.7469	0.0150
C25	HP-PR-CB21	PR-CBMH111	CONDUIT	3.0	11.7469	0.0150
C26	PR-CB30	HP-PR-CB30	CONDUIT	3.0	-8.3624	0.0150
C27	EX-CB137	HP-EX-CB137	CONDUIT	3.0	-6.6815	0.0150
C28	PR-CB31	HP-PR-CB31	CONDUIT	3.0	-8.3624	0.0150
C29	HP-PR-CB16/17	EX-CB137	CONDUIT	3.0	8.3624	0.0150
C3	HP-PR-CB28a	PR-CB27	CONDUIT	3.0	10.0504	0.0150
C30	PR-CB29	HP-PR-CB29	CONDUIT	3.0	-8.3624	0.0150
C31	PR-CB16/17	HP-PR-CB16/17	CONDUIT	3.0	-10.0504	0.0150
C32	PR-CBMH118	HP-PR-CBMH118	CONDUIT	3.0	-8.3624	0.0150
C33	EX-CB116	HP-EX-CB116	CONDUIT	3.0	-3.3352	0.0150
C34	PR-CBMH109	HP-PR-CBMH109	CONDUIT	3.0	-10.0504	0.0150
C35	HP-PR-CBMH109	PR-CB12	CONDUIT	3.0	10.0504	0.0150
C36	PR-CB12	HP-PR-CB12	CONDUIT	3.0	-9.0367	0.0150
C37	HP-PR-CB12	PR-CB11	CONDUIT	3.0	9.0367	0.0150

4837 Albion Road - Hard Rock Ottawa (116111)  
 PCSWMM Model Output - Pr. Conditions (100-year, 3-hour Chicago Storm)

C38	PR-CB11	HP-PR-CB11	CONDUIT	3.0	-8.3624	0.0150
C39	PR-CBMH108	HP-PR-CBMH108a	CONDUIT	3.0	-8.3624	0.0150
C4	PR-CB27	HP-PR-CB27a	CONDUIT	3.0	-10.0504	0.0150
C40	HP-PR-CBMH108a	PR-CB09	CONDUIT	3.0	8.3624	0.0150
C41	PR-CBMH108	HP-PR-CBMH108b	CONDUIT	3.0	-8.3624	0.0150
C42	HP-PR-CBMH108b	PR-CBMH106	CONDUIT	3.0	11.7469	0.0150
C43	PR-CB09	HP-PR-CB09	CONDUIT	3.0	-8.3624	0.0150
C44	HP-PR-CB09	PR-CB08	CONDUIT	3.0	11.7469	0.0150
C45	PR-CBMH106	HP-PR-CBMH106	CONDUIT	3.0	-10.0504	0.0150
C46	HP-PR-CBMH106	PR-CB08	CONDUIT	3.0	10.0504	0.0150
C47	PR-CB08	HP-PR-CB08	CONDUIT	3.0	-8.3624	0.0150
C48	HP-PR-CB08	PR-CB05	CONDUIT	3.0	10.0504	0.0150
C49	PR-CBMH104	HP-PR-CBMH104	CONDUIT	3.0	-8.3624	0.0150
C5	HP-PR-CB27a	PR-CBMH115	CONDUIT	3.0	10.0504	0.0150
C50	HP-PR-CBMH104	PR-CB05	CONDUIT	3.0	10.0504	0.0150
C51	PR-CB05	HP-PR-CB05	CONDUIT	3.0	-8.3624	0.0150
C52	HP-PR-CB05	PR-CB04	CONDUIT	3.0	10.0504	0.0150
C53	PR-CB01	HP-PR-CB01	CONDUIT	3.0	-6.6815	0.0150
C53_1	PR-CB04	HP-PR-CB04	CONDUIT	3.0	-8.3624	0.0150
C53_2	HP-PR-CB04	PR-CB02	CONDUIT	3.0	8.3624	0.0150
C54	PR-CB14	HP-PR-CB14	CONDUIT	3.0	-3.3352	0.0150
C54_1	PR-CB02	HP-PR-CB02	CONDUIT	3.0	-8.0257	0.0150
C54_2	HP-PR-CB02	PR-CB01	CONDUIT	3.0	8.0257	0.0150
C55	PR-CB03	HP-PR-CB03	CONDUIT	3.0	-8.0257	0.0150
C56	HP-PR-CB03	PR-CB01	CONDUIT	3.0	8.0257	0.0150
C57	PR-CBMH105	HP-PR-CBMH105	CONDUIT	3.0	-8.3624	0.0150
C58	HP-PR-CB36	PR-CB03	CONDUIT	3.0	8.6994	0.0150
C59	PR-CB38	HP-PR-CB06	CONDUIT	3.0	-6.6815	0.0150
C6	PR-CB28	HP-PR-CB28b	CONDUIT	3.0	-10.0504	0.0150
C60	HP-PR-CB06	PR-CBMH122	CONDUIT	3.0	6.6815	0.0150
C61	PR-CBMH122	HP-PR-CB07	CONDUIT	3.0	-6.6815	0.0150
C62	HP-PR-CB07	PR-CBMH105	CONDUIT	3.0	6.6815	0.0150
C63	PR-CB39	PR-CB38	CONDUIT	3.0	11.7469	0.0130
C65	HP-PR-CB14	PR-CB15	CONDUIT	3.0	8.3624	0.0150
C66	PR-CB15	HP-PR-CB15	CONDUIT	3.0	-9.0367	0.0150
C67	HP-PR-CB15	PR-CBMH110	CONDUIT	3.0	9.0367	0.0150
C68	PR-CBMH112	HP-PR-CBMH112	CONDUIT	3.0	-6.6815	0.0150
C69	HP-PR-CBMH112	PR-CB18	CONDUIT	3.0	11.7469	0.0150
C7	HP-PR-CB28b	PR-CB25	CONDUIT	3.0	22.1939	0.0150
C70	PR-TD02	HP-PR-TD02	CONDUIT	3.0	-20.4124	0.0150
C71	PR-CB20	HP-PR-CB20	CONDUIT	3.0	-5.0063	0.0150

C72	HP-PR-TD02	PR-CB40	CONDUIT	3.0	10.0504	0.0150
C73	PR-CB19	HP-PR-CB19	CONDUIT	3.0	-5.0063	0.0150
C74	PR-CBMH111	HP-PR-CBMH111	CONDUIT	3.0	-5.0063	0.0150
C75	PR-CB18	HP-PR-CB18	CONDUIT	3.0	-5.0063	0.0150
C76	HP-PR-CB18	EX-CB82	CONDUIT	3.0	50.8597	0.0150
C77	HP-PR-CB20	HP-01	CONDUIT	3.0	39.4116	0.0150
C78	EX-MH116	HP-EX-MH116	CONDUIT	3.0	1.0001	0.0150
C79	HP-PR-CB19	HP-01	CONDUIT	3.0	39.4116	0.0150
C8	PR-CB27	HP-PR-CB27b	CONDUIT	3.0	-10.0504	0.0150
C80	PR-CB40	HP-PR-CB40	CONDUIT	3.0	-8.3624	0.0150
C81	HP-PR-CBMH111	HP-01	CONDUIT	3.0	39.4116	0.0150
C82	HP-01	EX-CB14	CONDUIT	3.0	65.8553	0.0150
C83	EX-CB14	HP-EX-CB14	CONDUIT	3.0	-23.9957	0.0350
C84	EX-CB84	HP-EX-CB84	CONDUIT	3.0	-11.7469	0.0150
C84_2	EX-CB82	HP-EX-CB82	CONDUIT	3.0	-7.0172	0.0150
C85	HP-EX-CB84	HP-EX-CB137	CONDUIT	3.0	13.4535	0.0150
C86	HP-PR-CB40	PR-CB29	CONDUIT	3.0	18.6494	0.0150
C87	HP-EX-CB82	HP-EX-CB84	CONDUIT	3.0	1.6669	0.0150
C88	PR-CB32	HP-PR-CB32	CONDUIT	3.0	-3.3352	0.0150
C89	HP-EX-CB116	EX-CB117	CONDUIT	3.0	8.3624	0.0150
C9	HP-PR-CB27b	PR-CB24	CONDUIT	3.0	22.1939	0.0150
C90	EX-CB117	HP-EX-CB117	CONDUIT	3.0	-7.0172	0.0150
C91	HP-EX-CB117	PR-CB16/17	CONDUIT	3.0	7.0172	0.0150
C92	EX-CB64	HP-EX-CB64	CONDUIT	3.0	-5.0063	0.0150
C93	HP-EX-CB64	EX-CB117	CONDUIT	3.0	10.0504	0.0150
C94	PR-CBMH110	HP-PR-CBMH110	CONDUIT	3.0	-6.6815	0.0150
C95	HP-PR-CBMH110	EX-CB64	CONDUIT	3.0	3.3352	0.0150
C96	EX-CB62	HP-EX-CB62	CONDUIT	3.0	-4.6718	0.0150
C97	HP-EX-CB62	EX-CB60	CONDUIT	3.0	5.6758	0.0150
C98	EX-CB60	HP-EX-CB60	CONDUIT	3.0	-5.6758	0.0150
C99	HP-EX-CB60	EX-CB64	CONDUIT	3.0	13.4535	0.0150
C-CB22	PR-CB22	HP-PR-CB22	CONDUIT	3.0	-6.6815	0.0150
C-CB23	PR-CB23	HP-PR-CB23	CONDUIT	3.0	-6.6815	0.0150
C-CB24	PR-CBMH114	HP-PR-CBMH114	CONDUIT	3.0	-10.0504	0.0150
C-CB25	PR-CB25	HP-PR-CB25b	CONDUIT	3.0	-10.0504	0.0150
C-CB87	EX-CB87	HP-EX-CB87b	CONDUIT	3.0	-9.0367	0.0150
C-CBMH112	PR-CB21	HP-PR-CB21	CONDUIT	3.0	-6.6815	0.0150
C-CBMH114	PR-CB24	HP-PR-CB24b	CONDUIT	3.0	-10.0504	0.0150
EXMH101-OUT	EX-MH101	SWM_Pond	CONDUIT	80.9	2.0029	0.0130
EXMH115-101	EX-MH115	EX-MH101	CONDUIT	92.7	0.4962	0.0130
EXMH116-115	EX-MH116	EX-MH115	CONDUIT	91.3	0.4929	0.0130

4837 Albion Road - Hard Rock Ottawa (116111)  
 PCSWMM Model Output - Pr. Conditions (100-year, 3-hour Chicago Storm)

PRMH116-EX-MH116	PR-MH116	EX-MH116	CONDUIT	83.5	5.9025	0.0130
X-CB-129_(X-CB)	EX-CB128	EX-CB95	CONDUIT	7.2	0.6945	0.0130
X-CB-89_(X-CB)	EX-CB87	EX-MH106a	CONDUIT	20.8	3.8008	0.0130
X-CB-91_(X-CB)	EX-CB90	EX-MH106a	CONDUIT	15.6	5.1350	0.0130
X-CB-94_(X-CB)	EX-CB92	EX-MH107a	CONDUIT	21.4	1.3553	0.0130
X-CB-97_(X-CB)	EX-CB95	EX-CB96	CONDUIT	25.5	0.7059	0.0130
X-CB-98_(X-CB)	EX-CB96	EX-MH107a	CONDUIT	15.6	0.1282	0.0130
X-STM-13_(1)_(X-STM)	EX-MH101A	EX-MH101B	CONDUIT	30.1	1.3955	0.0130
X-STM-13_(X-STM)	EX-MH101B	EX-MH101	CONDUIT	32.6	2.2705	0.0130
X-STM-17_(X-STM)	EX-MH102	EX-MH101A	CONDUIT	29.4	1.5648	0.0130
X-STM-19_(X-STM)	EX-MH102A	EX-MH102	CONDUIT	58.6	0.8874	0.0130
X-STM-21_(X-STM)	EX-MH104	EX-MH102	CONDUIT	65.3	1.3171	0.0130
X-STM-23_(X-STM)	EX-MH105a	EX-MH104	CONDUIT	17.4	0.1724	0.0130
X-STM-25_(X-STM)_1	EX-MH106	EX-MH106a	CONDUIT	33.3	1.6218	0.0130
X-STM-25_(X-STM)_2	EX-MH106a	EX-MH105	CONDUIT	18.4	1.6850	0.0130
X-STM-27_(X-STM)_1	EX-MH107	EX-MH107a	CONDUIT	50.2	0.2988	0.0130
X-STM-27_(X-STM)_2	EX-MH107a	EX-MH106	CONDUIT	11.9	0.1681	0.0130
X-STM-29_(X-STM)	EX-CB28	EX-MH107	CONDUIT	14.8	0.0676	0.0130
X-STM-31_(X-STM)	EX-CB30	EX-MH107	CONDUIT	21.7	0.4608	0.0130
X-STM-33_(X-STM)	EX-MH109	EX-MH104	CONDUIT	86.5	0.3353	0.0130
X-STM-51_(X-STM)	EX-CB50	EX-MH112	CONDUIT	22.1	0.0905	0.0130
X-STM-53_(X-STM)	EX-CB52	EX-CB50	CONDUIT	55.0	0.1818	0.0130
X-STM-55_(X-STM)	EX-CB54	EX-CB52	CONDUIT	13.1	0.6107	0.0130
X-STM-59_(X-STM)	EX-CB58	EX-MH112	CONDUIT	11.9	1.0085	0.0130
X-STM-63_(X-STM)	EX-CB62	EX-CB60	CONDUIT	7.2	0.5556	0.0130
X-STM-71_(X-STM)	EX-MH103	EX-MH102	CONDUIT	78.6	1.0942	0.0130
X-STM-75_(X-STM)	EX-MH108	EX-MH109	CONDUIT	30.7	1.1076	0.0130
X-STM-77_(X-STM)	EX-STUB02	EX-MH108	CONDUIT	14.1	0.4255	0.0130
102_(5)_(CB)	PR-CBMH105	PR-MH101	ORIFICE			
114_(CB)	PR-CBMH111	PR-MH119	ORIFICE			
124_(CB)	PR-CB18	PR-MH119	ORIFICE			
131_(CB)	PR-CBMH118	PR-MH117	ORIFICE			
147_(CB)	PR-CBMH108	PR-MH101	ORIFICE			
267_(STM)	PR-CB41	PR-MH123	ORIFICE			
42_(STM)	PR-CBMH112	PR-MH113	ORIFICE			
46_(STM)	PR-CBMH114	PR-MH120	ORIFICE			
66_(CB)	PR-CBMH110	PR-MH103	ORIFICE			
69_(CB)	EX-CB117	EX-MH109	ORIFICE			
78_(CB)	PR-CB13	PR-MH102	ORIFICE			
81_(CB)	PR-CB14	PR-MH102	ORIFICE			
88_(CB)	PR-CBMH106	PR-MH101	ORIFICE			

96_(CB)	PR-CBMH104	PR-MH100a	ORIFICE			
OR1	PR-CB32	PR-MH117	ORIFICE			
OR10	PR-CB40	PR-OGS1	ORIFICE			
OR11	EX-MH112	EX-MH112a	ORIFICE			
OR12	PR-CB36	PR-MH100a	ORIFICE			
OR13	PR-CB29	PR-MH123	ORIFICE			
OR14	EX-CB134	PR-MH116	ORIFICE			
OR15	PR-TD02	PR-OGS1	ORIFICE			
OR2	PR-CBMH115	PR-CBMH115a	ORIFICE			
OR3	EX-CB60	PR-MH103	ORIFICE			
OR4	PR-CBMH109	PR-CBMH109a	ORIFICE			
OR5	PR-MH100	PR-MH100a	ORIFICE			
OR6	PR-CB16/17	EX-MH109	ORIFICE			
OR7	EX-MH105	EX-MH105a	ORIFICE			
OR8	EX-CB64	PR-MH104	ORIFICE			
OR9	PR-CBMH107	PR-MH101	ORIFICE			
X-CB-135_(X-CB)	EX-CB137	EX-MH109	ORIFICE			
X-CB-83_(X-CB)	EX-CB82	EX-MH104	ORIFICE			
X-CB-86_(X-CB)	EX-CB84	EX-MH104	ORIFICE			
X-STM-15_(X-STM)	EX-CB14	EX-MH101A	ORIFICE			
X-STM-73_(X-STM)	EX-CB72	EX-MH103	ORIFICE			
EX-BLDG01-OUT	EX-BLDG01	EX-STUB02	OUTLET			
INFIL-EX-CB116	EX-CB116	IF-EX-CB116	OUTLET			
INFIL-EX-CB117	EX-CB117	IF-EX-CB117	OUTLET			
INFIL-EX-CB128	EX-CB128	IF-EX-CB128	OUTLET			
INFIL-EX-CB137	EX-CB137	IF-EX-CB137	OUTLET			
INFIL-EX-CB14	EX-CB14	IF-EX-CB14	OUTLET			
INFIL-EX-CB28	EX-CB28	IF-EX-CB28	OUTLET			
INFIL-EX-CB30	EX-CB30	IF-EX-CB30	OUTLET			
INFIL-EX-CB50	EX-CB50	IF-EX-CB50	OUTLET			
INFIL-EX-CB52	EX-CB52	IF-EX-CB52	OUTLET			
INFIL-EX-CB54	EX-CB54	IF-EX-CB54	OUTLET			
INFIL-EX-CB58	EX-CB58	IF-EX-CB58	OUTLET			
INFIL-EX-CB64	EX-CB64	IF-EX-CB64	OUTLET			
INFIL-EX-CB82	EX-CB82	IF-EX-CB82	OUTLET			
INFIL-EX-CB84	EX-CB84	IF-EX-CB84	OUTLET			
INFIL-EX-CB87	EX-CB87	IF-EX-CB87	OUTLET			
INFIL-EX-CB90	EX-CB90	IF-EX-CB90	OUTLET			
INFIL-EX-CB92	EX-CB92	IF-EX-CB92	OUTLET			
INFIL-EX-CB95	EX-CB95	IF-EX-CB95	OUTLET			
INFIL-EX-CB96	EX-CB96	IF-EX-CB96	OUTLET			

4837 Albion Road - Hard Rock Ottawa (116111)  
 PCSWMM Model Output - Pr. Conditions (100-year, 3-hour Chicago Storm)

INFIL-PR-CB04	PR-CB04	IF-PR-CB04	OUTLET
INFIL-PR-CB13	PR-CB13	IF-PR-CB13	OUTLET
INFIL-PR-CB14	PR-CB14	IF-PR-CB14	OUTLET
INFIL-PR-CB18	PR-CB18	IF-PR-CB18	OUTLET
INFIL-PR-CB29	PR-CB29	IF-PR-CB29	OUTLET
INFIL-PR-CB32	PR-CB32	IF-PR-CB32	OUTLET
INFIL-PR-CB36	PR-CB36	IF-PR-CB36	OUTLET
INFIL-PR-CB40	PR-CB40	IF-PR-CB40	OUTLET
INFIL-PR-CBMH104	PR-CBMH104	IF-PR-CBMH104	OUTLET
INFIL-PR-CBMH105	PR-CBMH105	IF-PR-CBMH105	OUTLET
INFIL-PR-CBMH106	PR-CBMH106	IF-PR-CBMH106	OUTLET
INFIL-PR-CBMH107	PR-CBMH107	IF-PR-CBMH107	OUTLET
INFIL-PR-CBMH108	PR-CBMH108	IF-PR-CBMH108	OUTLET
INFIL-PR-CBMH109	PR-CBMH109	IF-PR-CBMH109	OUTLET
INFIL-PR-CBMH110	PR-CBMH110	IF-PR-CBMH110	OUTLET
INFIL-PR-CBMH111	PR-CBMH111	IF-PR-CBMH111	OUTLET
INFIL-PR-CBMH112	PR-CBMH112	IF-PR-CBMH112	OUTLET
INFIL-PR-CBMH114	PR-CBMH114	IF-PR-CBMH114	OUTLET
INFIL-PR-CBMH115	PR-CBMH115	IF-PR-CBMH115	OUTLET
INFIL-PR-CBMH118	PR-CBMH118	IF-PR-CBMH118	OUTLET
PR-BLDG01-OUT	PR-BLDG01	EX-MH109	OUTLET
PR-BLDG02-OUT	PR-BLDG02	PR-STUB01	OUTLET

\*\*\*\*\*  
 Cross Section Summary  
 \*\*\*\*\*

Conduit	Shape	Full Depth	Full Area	Hyd. Rad.	Max. Width	No. of Barrels	Full Flow
108_(CB)	CIRCULAR	0.25	0.05	0.06	0.25	1	42.92
115_(CB)	CIRCULAR	0.30	0.07	0.07	0.30	1	96.99
121_(CB)	CIRCULAR	0.30	0.07	0.07	0.30	1	68.13
138_(CB)_1	CIRCULAR	0.30	0.07	0.07	0.30	1	53.84
138_(CB)_2	CIRCULAR	0.30	0.07	0.07	0.30	1	54.06
14_(STM)	CIRCULAR	0.30	0.07	0.07	0.30	1	43.01
142_(STM)	CIRCULAR	0.30	0.07	0.07	0.30	1	58.00
145_(CB)	CIRCULAR	0.25	0.05	0.06	0.25	1	41.59
150_(1)_(STM)	CIRCULAR	0.30	0.07	0.07	0.30	1	68.19
156_(STM)	CIRCULAR	0.25	0.05	0.06	0.25	1	42.97
163_(STM)	CIRCULAR	0.30	0.07	0.07	0.30	1	70.16

165_(CB)	CIRCULAR	0.30	0.07	0.07	0.30	1	69.19
17_(1)_(STM)	CIRCULAR	0.30	0.07	0.07	0.30	1	68.57
20_(STM)	CIRCULAR	0.25	0.05	0.06	0.25	1	84.11
226_(CB)	CIRCULAR	0.25	0.05	0.06	0.25	1	42.65
230_(CB)	CIRCULAR	0.25	0.05	0.06	0.25	1	42.54
246_(CB)	CIRCULAR	0.25	0.05	0.06	0.25	1	41.71
250_(CB)	CIRCULAR	0.25	0.05	0.06	0.25	1	41.08
251_(CB)	CIRCULAR	0.25	0.05	0.06	0.25	1	42.35
268_(STM)	CIRCULAR	0.30	0.07	0.07	0.30	1	68.80
271_(CB)	CIRCULAR	0.20	0.03	0.05	0.20	1	23.58
28_(1)_(STM)	CIRCULAR	0.30	0.07	0.07	0.30	1	96.00
28_(STM)	CIRCULAR	0.30	0.07	0.07	0.30	1	96.87
30_(STM)	CIRCULAR	0.30	0.07	0.07	0.30	1	86.63
32_(STM)	CIRCULAR	0.30	0.07	0.07	0.30	1	97.03
34_(1)_(STM)	CIRCULAR	0.25	0.05	0.06	0.25	1	41.59
34_(STM)	CIRCULAR	0.25	0.05	0.06	0.25	1	54.58
36_(1)_(STM)	CIRCULAR	0.30	0.07	0.07	0.30	1	67.63
36_(STM)	CIRCULAR	0.30	0.07	0.07	0.30	1	67.63
42_(1)_(STM)	CIRCULAR	0.30	0.07	0.07	0.30	1	69.49
42_(2)_(STM)	CIRCULAR	0.30	0.07	0.07	0.30	1	67.63
49_(STM)	CIRCULAR	0.30	0.07	0.07	0.30	1	67.36
5_(STM)_1	CIRCULAR	0.45	0.16	0.11	0.45	1	154.50
5_(STM)_2	CIRCULAR	0.45	0.16	0.11	0.45	1	154.13
54_(STM)	CIRCULAR	0.30	0.07	0.07	0.30	1	67.63
57_(STM)	CIRCULAR	0.30	0.07	0.07	0.30	1	67.98
59_(STM)	CIRCULAR	0.25	0.05	0.06	0.25	1	41.65
61_(STM)	CIRCULAR	0.25	0.05	0.06	0.25	1	42.24
64_(CB)	CIRCULAR	0.25	0.05	0.06	0.25	1	59.57
7_(STM)	CIRCULAR	0.53	0.22	0.13	0.53	1	232.59
86_(CB)	CIRCULAR	0.25	0.05	0.06	0.25	1	41.59
9_(1)_(STM)	CIRCULAR	0.60	0.28	0.15	0.60	1	338.54
9_(STM)_2	CIRCULAR	0.60	0.28	0.15	0.60	1	333.59
94_(CB)	CIRCULAR	0.25	0.05	0.06	0.25	1	42.36
C1	CIRCULAR	0.20	0.03	0.05	0.20	1	88.62
C10	RECT_OPEN	1.00	3.00	0.60	3.00	1	45107.44
C100	RECT_OPEN	1.00	3.00	0.60	3.00	1	47334.20
C101	RECT_OPEN	1.00	3.00	0.60	3.00	1	45107.44
C102	RECT_OPEN	1.00	3.00	0.60	3.00	1	47334.20
C103	RECT_OPEN	1.00	3.00	0.60	3.00	1	43563.76
C104	RECT_OPEN	1.00	3.00	0.60	3.00	1	42772.17
C105	RECT_OPEN	1.00	3.00	0.60	3.00	1	45107.44



4837 Albion Road - Hard Rock Ottawa (116111)  
 PCSWMM Model Output - Pr. Conditions (100-year, 3-hour Chicago Storm)

C106	RECT_OPEN	1.00	3.00	0.60	3.00	1 48766.13
C107	RECT_OPEN	1.00	3.00	0.60	3.00	1 48766.13
C108	RECT_OPEN	1.00	3.00	0.60	3.00	1 50844.53
C109	RECT_OPEN	1.00	3.00	0.60	3.00	1 47334.20
C11	RECT_OPEN	1.00	3.00	0.60	3.00	1 45107.44
C110	RECT_OPEN	1.00	3.00	0.60	3.00	1 31835.65
C111	RECT_OPEN	1.00	3.00	0.60	3.00	1 43563.76
C112	RECT_OPEN	1.00	3.00	0.60	3.00	1 47334.20
C113	RECT_OPEN	1.00	3.00	0.60	3.00	1 31835.65
C114	RECT_OPEN	1.00	3.00	0.60	3.00	1 33897.68
C115	RECT_OPEN	1.00	3.00	0.60	3.00	1 44341.94
C116	RECT_OPEN	1.00	3.00	0.60	3.00	1 44341.94
C117	RECT_OPEN	1.00	3.00	0.60	3.00	1 44341.94
C118	RECT_OPEN	1.00	3.00	0.60	3.00	1 44341.94
C119	RECT_OPEN	1.00	3.00	0.60	3.00	1 42772.17
C12	RECT_OPEN	1.00	3.00	0.60	3.00	1 45107.44
C120	RECT_OPEN	1.00	3.00	0.60	3.00	1 47334.20
C121	RECT_OPEN	1.00	3.00	0.60	3.00	1 43563.76
C122	RECT_OPEN	1.00	3.00	0.60	3.00	1 43563.76
C123	RECT_OPEN	1.00	3.00	0.60	3.00	1 40308.73
C124	RECT_OPEN	1.00	3.00	0.60	3.00	1 35843.43
C125	RECT_OPEN	1.00	3.00	0.60	3.00	1 30753.68
C126	RECT_OPEN	1.00	3.00	0.60	3.00	1 42772.17
C127	RECT_OPEN	1.00	3.00	0.60	3.00	1 47334.20
C128	RECT_OPEN	1.00	3.00	0.60	3.00	1 21737.24
C129	RECT_OPEN	1.00	3.00	0.60	3.00	1 33897.68
C13	RECT_OPEN	1.00	3.00	0.60	3.00	1 45107.44
C130	RECT_OPEN	1.00	3.00	0.60	3.00	1 44341.94
C131	RECT_OPEN	1.00	3.00	0.60	3.00	1 64284.19
C132	RECT_OPEN	1.00	3.00	0.60	3.00	1 42772.17
C133	RECT_OPEN	1.00	3.00	0.60	3.00	1 42772.17
C134	RECT_OPEN	1.00	3.00	0.60	3.00	1 58497.86
C135	RECT_OPEN	1.00	3.00	0.60	3.00	1 69698.53
C136	RECT_OPEN	1.00	3.00	0.60	3.00	1 25984.66
C137	RECT_OPEN	1.00	3.00	0.60	3.00	1 14228.79
C138	RECT_OPEN	1.00	3.00	0.60	3.00	1 40308.73
C139	RECT_OPEN	1.00	3.00	0.60	3.00	1 45107.44
C14	RECT_OPEN	1.00	3.00	0.60	3.00	1 45107.44
C140	RECT_OPEN	1.00	3.00	0.60	3.00	1 61445.45
C141	RECT_OPEN	1.00	3.00	0.60	3.00	1 64284.19
C142	RECT_OPEN	1.00	3.00	0.60	3.00	1 41145.56

C143	RECT_OPEN	1.00	3.00	0.60	3.00	1 41145.56
C144	RECT_OPEN	1.00	3.00	0.60	3.00	1 41145.56
C145	RECT_OPEN	1.00	3.00	0.60	3.00	1 37691.14
C146	RECT_OPEN	1.00	3.00	0.60	3.00	1 41145.56
C147	RECT_OPEN	1.00	3.00	0.60	3.00	1 52047.05
C148	RECT_OPEN	1.00	3.00	0.60	3.00	1 36778.58
C149	RECT_OPEN	1.00	3.00	0.60	3.00	1 45107.44
C15	RECT_OPEN	1.00	3.00	0.60	3.00	1 45107.44
C150	RECT_OPEN	1.00	3.00	0.60	3.00	1 25984.66
C151	RECT_OPEN	1.00	3.00	0.60	3.00	1 67030.66
C152	RECT_OPEN	1.00	3.00	0.60	3.00	1 48766.13
C16	RECT_OPEN	1.00	3.00	0.60	3.00	1 45107.44
C17	RECT_OPEN	1.00	3.00	0.60	3.00	1 67030.66
C18	RECT_OPEN	1.00	3.00	0.60	3.00	1 45107.44
C19	RECT_OPEN	1.00	3.00	0.60	3.00	1 67030.66
C2	RECT_OPEN	1.00	3.00	0.60	3.00	1 45107.44
C20	RECT_OPEN	1.00	3.00	0.60	3.00	1 67030.66
C21	RECT_OPEN	1.00	3.00	0.60	3.00	1 67030.66
C22	RECT_OPEN	1.00	3.00	0.60	3.00	1 67030.66
C23	RECT_OPEN	1.00	3.00	0.60	3.00	1 48766.13
C24	RECT_OPEN	1.00	3.00	0.60	3.00	1 48766.13
C25	RECT_OPEN	1.00	3.00	0.60	3.00	1 48766.13
C26	RECT_OPEN	1.00	3.00	0.60	3.00	1 41145.56
C27	RECT_OPEN	1.00	3.00	0.60	3.00	1 36778.58
C28	RECT_OPEN	1.00	3.00	0.60	3.00	1 41145.56
C29	RECT_OPEN	1.00	3.00	0.60	3.00	1 41145.56
C3	RECT_OPEN	1.00	3.00	0.60	3.00	1 45107.44
C30	RECT_OPEN	1.00	3.00	0.60	3.00	1 41145.56
C31	RECT_OPEN	1.00	3.00	0.60	3.00	1 45107.44
C32	RECT_OPEN	1.00	3.00	0.60	3.00	1 41145.56
C33	RECT_OPEN	1.00	3.00	0.60	3.00	1 25984.66
C34	RECT_OPEN	1.00	3.00	0.60	3.00	1 45107.44
C35	RECT_OPEN	1.00	3.00	0.60	3.00	1 45107.44
C36	RECT_OPEN	1.00	3.00	0.60	3.00	1 42772.17
C37	RECT_OPEN	1.00	3.00	0.60	3.00	1 42772.17
C38	RECT_OPEN	1.00	3.00	0.60	3.00	1 41145.56
C39	RECT_OPEN	1.00	3.00	0.60	3.00	1 41145.56
C4	RECT_OPEN	1.00	3.00	0.60	3.00	1 45107.44
C40	RECT_OPEN	1.00	3.00	0.60	3.00	1 41145.56
C41	RECT_OPEN	1.00	3.00	0.60	3.00	1 41145.56
C42	RECT_OPEN	1.00	3.00	0.60	3.00	1 48766.13

4837 Albion Road - Hard Rock Ottawa (116111)  
 PCSWMM Model Output - Pr. Conditions (100-year, 3-hour Chicago Storm)

C43	RECT_OPEN	1.00	3.00	0.60	3.00	1 41145.56
C44	RECT_OPEN	1.00	3.00	0.60	3.00	1 48766.13
C45	RECT_OPEN	1.00	3.00	0.60	3.00	1 45107.44
C46	RECT_OPEN	1.00	3.00	0.60	3.00	1 45107.44
C47	RECT_OPEN	1.00	3.00	0.60	3.00	1 41145.56
C48	RECT_OPEN	1.00	3.00	0.60	3.00	1 45107.44
C49	RECT_OPEN	1.00	3.00	0.60	3.00	1 41145.56
C5	RECT_OPEN	1.00	3.00	0.60	3.00	1 45107.44
C50	RECT_OPEN	1.00	3.00	0.60	3.00	1 45107.44
C51	RECT_OPEN	1.00	3.00	0.60	3.00	1 41145.56
C52	RECT_OPEN	1.00	3.00	0.60	3.00	1 45107.44
C53	RECT_OPEN	1.00	3.00	0.60	3.00	1 36778.58
C53_1	RECT_OPEN	1.00	3.00	0.60	3.00	1 41145.56
C53_2	RECT_OPEN	1.00	3.00	0.60	3.00	1 41145.56
C54	RECT_OPEN	1.00	3.00	0.60	3.00	1 25984.66
C54_1	RECT_OPEN	1.00	3.00	0.60	3.00	1 40308.73
C54_2	RECT_OPEN	1.00	3.00	0.60	3.00	1 40308.73
C55	RECT_OPEN	1.00	3.00	0.60	3.00	1 40308.73
C56	RECT_OPEN	1.00	3.00	0.60	3.00	1 40308.73
C57	RECT_OPEN	1.00	3.00	0.60	3.00	1 41145.56
C58	RECT_OPEN	1.00	3.00	0.60	3.00	1 41966.39
C59	RECT_OPEN	1.00	3.00	0.60	3.00	1 36778.58
C6	RECT_OPEN	1.00	3.00	0.60	3.00	1 45107.44
C60	RECT_OPEN	1.00	3.00	0.60	3.00	1 36778.58
C61	RECT_OPEN	1.00	3.00	0.60	3.00	1 36778.58
C62	RECT_OPEN	1.00	3.00	0.60	3.00	1 36778.58
C63	RECT_OPEN	1.00	3.00	0.60	3.00	1 56268.62
C65	RECT_OPEN	1.00	3.00	0.60	3.00	1 41145.56
C66	RECT_OPEN	1.00	3.00	0.60	3.00	1 42772.17
C67	RECT_OPEN	1.00	3.00	0.60	3.00	1 42772.17
C68	RECT_OPEN	1.00	3.00	0.60	3.00	1 36778.58
C69	RECT_OPEN	1.00	3.00	0.60	3.00	1 48766.13
C7	RECT_OPEN	1.00	3.00	0.60	3.00	1 67030.66
C70	RECT_OPEN	1.00	3.00	0.60	3.00	1 64284.19
C71	RECT_OPEN	1.00	3.00	0.60	3.00	1 31835.65
C72	RECT_OPEN	1.00	3.00	0.60	3.00	1 45107.44
C73	RECT_OPEN	1.00	3.00	0.60	3.00	1 31835.65
C74	RECT_OPEN	1.00	3.00	0.60	3.00	1 31835.65
C75	RECT_OPEN	1.00	3.00	0.60	3.00	1 31835.65
C76	RECT_OPEN	1.00	3.00	0.60	3.00	1 101471.45
C77	RECT_OPEN	1.00	3.00	0.60	3.00	1 89324.16

C78	RECT_OPEN	1.00	3.00	0.60	3.00	1 14228.79
C79	RECT_OPEN	1.00	3.00	0.60	3.00	1 89324.16
C8	RECT_OPEN	1.00	3.00	0.60	3.00	1 45107.44
C80	RECT_OPEN	1.00	3.00	0.60	3.00	1 41145.56
C81	RECT_OPEN	1.00	3.00	0.60	3.00	1 89324.16
C82	RECT_OPEN	1.00	3.00	0.60	3.00	1 115465.51
C83	RECT_OPEN	1.00	3.00	0.60	3.00	1 29870.80
C84	RECT_OPEN	1.00	3.00	0.60	3.00	1 48766.13
C84_2	RECT_OPEN	1.00	3.00	0.60	3.00	1 37691.14
C85	RECT_OPEN	1.00	3.00	0.60	3.00	1 52188.39
C86	RECT_OPEN	1.00	3.00	0.60	3.00	1 61445.45
C87	RECT_OPEN	1.00	3.00	0.60	3.00	1 18370.10
C88	RECT_OPEN	1.00	3.00	0.60	3.00	1 25984.66
C89	RECT_OPEN	1.00	3.00	0.60	3.00	1 41145.56
C9	RECT_OPEN	1.00	3.00	0.60	3.00	1 67030.66
C90	RECT_OPEN	1.00	3.00	0.60	3.00	1 37691.14
C91	RECT_OPEN	1.00	3.00	0.60	3.00	1 37691.14
C92	RECT_OPEN	1.00	3.00	0.60	3.00	1 31835.65
C93	RECT_OPEN	1.00	3.00	0.60	3.00	1 45107.44
C94	RECT_OPEN	1.00	3.00	0.60	3.00	1 36778.58
C95	RECT_OPEN	1.00	3.00	0.60	3.00	1 25984.66
C96	RECT_OPEN	1.00	3.00	0.60	3.00	1 30753.68
C97	RECT_OPEN	1.00	3.00	0.60	3.00	1 33897.68
C98	RECT_OPEN	1.00	3.00	0.60	3.00	1 33897.68
C99	RECT_OPEN	1.00	3.00	0.60	3.00	1 52188.39
C-CB22	RECT_OPEN	1.00	3.00	0.60	3.00	1 36778.58
C-CB23	RECT_OPEN	1.00	3.00	0.60	3.00	1 36778.58
C-CB24	RECT_OPEN	1.00	3.00	0.60	3.00	1 45107.44
C-CB25	RECT_OPEN	1.00	3.00	0.60	3.00	1 45107.44
C-CB87	RECT_OPEN	1.00	3.00	0.60	3.00	1 42772.17
C-CBMH112	RECT_OPEN	1.00	3.00	0.60	3.00	1 36778.58
C-CBMH114	RECT_OPEN	1.00	3.00	0.60	3.00	1 45107.44
EXMH101-OUT	CIRCULAR	0.75	0.44	0.19	0.75	1 1575.64
EXMH115-101	CIRCULAR	0.30	0.07	0.07	0.30	1 68.12
EXMH116-115	CIRCULAR	0.30	0.07	0.07	0.30	1 67.89
PRMH116-EX-MH116	CIRCULAR	0.25	0.05	0.06	0.25	1 144.49
X-CB-129_(X-CB)	CIRCULAR	0.20	0.03	0.05	0.20	1 27.33
X-CB-89_(X-CB)	CIRCULAR	0.20	0.03	0.05	0.20	1 63.95
X-CB-91_(X-CB)	CIRCULAR	0.20	0.03	0.05	0.20	1 74.33
X-CB-94_(X-CB)	CIRCULAR	0.20	0.03	0.05	0.20	1 38.18
X-CB-97_(X-CB)	CIRCULAR	0.30	0.07	0.07	0.30	1 81.25

4837 Albion Road - Hard Rock Ottawa (116111)  
 PCSWMM Model Output - Pr. Conditions (100-year, 3-hour Chicago Storm)

Node	Type	Flow	Depth	Velocity	Area	Volume
X-CB-98_(X-CB)	CIRCULAR	0.30	0.07	0.07	0.30	1 34.63
X-STM-13_(1)_(X-STM)	CIRCULAR	0.75	0.44	0.19	0.75	1 1315.20
X-STM-13_(X-STM)	CIRCULAR	0.75	0.44	0.19	0.75	1 1677.62
X-STM-17_(X-STM)	CIRCULAR	0.75	0.44	0.19	0.75	1 1392.71
X-STM-19_(X-STM)	CIRCULAR	0.30	0.07	0.07	0.30	1 91.10
X-STM-21_(X-STM)	CIRCULAR	0.60	0.28	0.15	0.60	1 704.72
X-STM-23_(X-STM)	CIRCULAR	0.45	0.16	0.11	0.45	1 118.39
X-STM-25_(X-STM)_1	CIRCULAR	0.45	0.16	0.11	0.45	1 363.11
X-STM-25_(X-STM)_2	CIRCULAR	0.45	0.16	0.11	0.45	1 370.11
X-STM-27_(X-STM)_1	CIRCULAR	0.30	0.07	0.07	0.30	1 52.86
X-STM-27_(X-STM)_2	CIRCULAR	0.30	0.07	0.07	0.30	1 39.65
X-STM-29_(X-STM)	CIRCULAR	0.30	0.07	0.07	0.30	1 25.14
X-STM-31_(X-STM)	CIRCULAR	0.30	0.07	0.07	0.30	1 65.65
X-STM-33_(X-STM)	CIRCULAR	0.60	0.28	0.15	0.60	1 355.55
X-STM-51_(X-STM)	CIRCULAR	0.30	0.07	0.07	0.30	1 29.09
X-STM-53_(X-STM)	CIRCULAR	0.30	0.07	0.07	0.30	1 41.24
X-STM-55_(X-STM)	CIRCULAR	0.25	0.05	0.06	0.25	1 46.48
X-STM-59_(X-STM)	CIRCULAR	0.20	0.03	0.05	0.20	1 32.94
X-STM-63_(X-STM)	CIRCULAR	0.20	0.03	0.05	0.20	1 24.45
X-STM-71_(X-STM)	CIRCULAR	0.30	0.07	0.07	0.30	1 101.16
X-STM-75_(X-STM)	CIRCULAR	0.38	0.11	0.09	0.38	1 184.53
X-STM-77_(X-STM)	CIRCULAR	0.38	0.11	0.09	0.38	1 114.38

\*\*\*\*\*  
 NOTE: The summary statistics displayed in this report are based on results found at every computational time step, not just on results from each reporting time step.  
 \*\*\*\*\*

\*\*\*\*\*  
 Analysis Options  
 \*\*\*\*\*  
 Flow Units ..... LPS  
 Process Models:  
 Rainfall/Runoff ..... YES  
 RDII ..... NO  
 Snowmelt ..... NO  
 Groundwater ..... NO  
 Flow Routing ..... YES

Ponding Allowed ..... NO  
 Water Quality ..... NO  
 Infiltration Method ..... HORTON  
 Flow Routing Method ..... DYNWAVE  
 Surcharge Method ..... EXTRAN  
 Starting Date ..... 10/24/2019 00:00:00  
 Ending Date ..... 10/25/2019 00:00:00  
 Antecedent Dry Days ..... 0.0  
 Report Time Step ..... 00:01:00  
 Wet Time Step ..... 00:01:00  
 Dry Time Step ..... 00:01:00  
 Routing Time Step ..... 2.00 sec  
 Variable Time Step ..... YES  
 Maximum Trials ..... 8  
 Number of Threads ..... 4  
 Head Tolerance ..... 0.001500 m

	Volume	Depth
Runoff Quantity Continuity	hectare-m	mm
-----	-----	-----
Total Precipitation	1.023	71.667
Evaporation Loss	0.000	0.000
Infiltration Loss	0.103	7.225
Surface Runoff	0.906	63.434
Final Storage	0.015	1.072
Continuity Error (%)	-0.090	

	Volume	Volume
Flow Routing Continuity	hectare-m	10^6 ltr
-----	-----	-----
Dry Weather Inflow	0.000	0.000
Wet Weather Inflow	0.906	9.057
Groundwater Inflow	0.000	0.000
RDII Inflow	0.000	0.000
External Inflow	0.000	0.000
External Outflow	0.908	9.082
Flooding Loss	0.000	0.000
Evaporation Loss	0.000	0.000
Exfiltration Loss	0.000	0.000





4837 Albion Road - Hard Rock Ottawa (116111)  
 PCSWMM Model Output - Pr. Conditions (100-year, 3-hour Chicago Storm)

A-45a		71.67	0.00	0.00	0.00	70.19	0.00	70.19	0.02
14.38	0.979								
A-46		71.67	0.00	0.00	0.00	70.16	0.00	70.16	0.09
60.48	0.979								
A-47		71.67	0.00	0.00	22.50	35.10	13.35	48.45	0.04
32.09	0.676								
A-48		71.67	0.00	0.00	5.65	61.16	3.62	64.77	0.03
20.45	0.904								
A-49		71.67	0.00	0.00	26.91	28.09	16.11	44.20	0.04
33.30	0.617								
A-50		71.67	0.00	0.00	19.18	40.08	11.59	51.68	0.03
25.33	0.721								
A-51		71.67	0.00	0.00	0.61	69.22	0.40	69.61	0.06
44.06	0.971								
A-52		71.67	0.00	0.00	8.21	57.13	5.14	62.27	0.03
24.95	0.869								
A-52a		71.67	0.00	0.00	0.00	70.22	0.00	70.22	0.01
4.96	0.980								
A-53		71.67	0.00	0.00	12.01	51.17	7.43	58.60	0.05
42.87	0.818								
A-54		71.67	0.00	0.00	12.65	50.12	7.87	57.99	0.02
18.23	0.809								
A-55		71.67	0.00	0.00	8.79	56.17	5.57	61.73	0.04
27.42	0.861								
A-56		71.67	0.00	0.00	0.00	70.19	0.00	70.19	0.06
41.17	0.979								
A-57		71.67	0.00	0.00	1.27	68.55	0.82	69.37	0.02
15.81	0.968								
A-58		71.67	0.00	0.00	13.86	48.43	8.67	57.11	0.02
16.87	0.797								
A-60		71.67	0.00	0.00	1.27	68.15	0.82	68.97	0.08
57.30	0.962								
A-61		71.67	0.00	0.00	0.00	70.20	0.00	70.20	0.07
51.09	0.980								
A-62		71.67	0.00	0.00	0.00	70.19	0.00	70.19	0.08
56.05	0.979								
A-63		71.67	0.00	0.00	0.00	70.19	0.00	70.19	0.09
65.47	0.979								
A-65		71.67	0.00	0.00	0.00	70.18	0.00	70.18	0.15
108.62	0.979								
A-66		71.67	0.00	0.00	0.00	70.19	0.00	70.19	0.14
98.70	0.979								
A-67		71.67	0.00	0.00	0.00	70.19	0.00	70.19	0.10
73.41	0.979								

A-68		71.67	0.00	0.00	16.60	44.15	10.01	54.16	0.06
46.25	0.756								
A-69		71.67	0.00	0.00	11.41	52.15	7.03	59.18	0.08
65.68	0.826								
A-70		71.67	0.00	0.00	0.00	70.21	0.00	70.21	0.01
8.93	0.980								

\*\*\*\*\*  
 Node Depth Summary  
 \*\*\*\*\*

Node	Type	Average Depth Meters	Maximum Depth Meters	Maximum HGL Meters	Time of Max Occurrence days hr:min	Reported Max Depth Meters
HP-01	JUNCTION	0.00	0.00	114.10	0 01:38	0.00
HP-EX-CB116	JUNCTION	0.00	0.00	113.60	0 00:00	0.00
HP-EX-CB117	JUNCTION	0.00	0.00	113.56	0 00:00	0.00
HP-EX-CB128a	JUNCTION	0.00	0.00	113.90	0 00:00	0.00
HP-EX-CB128b	JUNCTION	0.00	0.00	113.95	0 00:00	0.00
HP-EX-CB131	JUNCTION	0.00	0.00	112.90	0 00:00	0.00
HP-EX-CB134	JUNCTION	0.00	0.01	113.41	0 01:10	0.01
HP-EX-CB137	JUNCTION	0.00	0.00	113.60	0 00:00	0.00
HP-EX-CB28	JUNCTION	0.00	0.00	114.00	0 00:00	0.00
HP-EX-CB30a	JUNCTION	0.00	0.00	114.00	0 00:00	0.00
HP-EX-CB30b	JUNCTION	0.00	0.00	114.00	0 00:00	0.00
HP-EX-CB50a	JUNCTION	0.00	0.00	114.00	0 00:00	0.00
HP-EX-CB50b	JUNCTION	0.00	0.00	114.00	0 00:00	0.00
HP-EX-CB52	JUNCTION	0.00	0.00	113.98	0 00:00	0.00
HP-EX-CB54	JUNCTION	0.00	0.00	114.00	0 00:00	0.00
HP-EX-CB58a	JUNCTION	0.00	0.00	114.00	0 00:00	0.00
HP-EX-CB58b	JUNCTION	0.00	0.00	114.00	0 00:00	0.00
HP-EX-CB60	JUNCTION	0.00	0.00	113.90	0 00:00	0.00
HP-EX-CB62	JUNCTION	0.00	0.00	113.90	0 00:00	0.00
HP-EX-CB64	JUNCTION	0.00	0.01	113.66	0 01:20	0.00
HP-EX-CB72	JUNCTION	0.00	0.00	113.00	0 00:00	0.00
HP-EX-CB82	JUNCTION	0.00	0.00	114.05	0 00:00	0.00
HP-EX-CB84	JUNCTION	0.00	0.00	114.00	0 00:00	0.00
HP-EX-CB87a	JUNCTION	0.00	0.00	113.95	0 00:00	0.00

4837 Albion Road - Hard Rock Ottawa (116111)  
 PCSWMM Model Output - Pr. Conditions (100-year, 3-hour Chicago Storm)

HP-EX-CB87b	JUNCTION	0.00	0.00	113.95	0	00:00	0.00
HP-EX-CB90	JUNCTION	0.00	0.00	113.95	0	00:00	0.00
HP-EX-CB92	JUNCTION	0.00	0.00	113.95	0	00:00	0.00
HP-EX-CB95	JUNCTION	0.00	0.00	113.95	0	00:00	0.00
HP-EX-CB96	JUNCTION	0.00	0.00	113.95	0	00:00	0.00
HP-PR-CB01	JUNCTION	0.00	0.00	113.60	0	00:00	0.00
HP-PR-CB02	JUNCTION	0.00	0.00	113.64	0	00:00	0.00
HP-PR-CB03	JUNCTION	0.00	0.00	113.64	0	00:00	0.00
HP-PR-CB04	JUNCTION	0.00	0.00	113.65	0	00:00	0.00
HP-PR-CB05	JUNCTION	0.00	0.00	113.70	0	00:00	0.00
HP-PR-CB06	JUNCTION	0.00	0.00	113.65	0	00:00	0.00
HP-PR-CB07	JUNCTION	0.00	0.00	113.65	0	00:00	0.00
HP-PR-CB08	JUNCTION	0.00	0.00	113.75	0	00:00	0.00
HP-PR-CB09	JUNCTION	0.00	0.00	113.85	0	00:00	0.00
HP-PR-CB12	JUNCTION	0.00	0.00	113.87	0	00:00	0.00
HP-PR-CB13	JUNCTION	0.00	0.01	113.73	0	01:08	0.01
HP-PR-CB14	JUNCTION	0.00	0.01	113.66	0	01:11	0.00
HP-PR-CB15	JUNCTION	0.00	0.00	113.67	0	00:00	0.00
HP-PR-CB16/17	JUNCTION	0.00	0.00	113.65	0	00:00	0.00
HP-PR-CB18	JUNCTION	0.00	0.00	115.20	0	00:00	0.00
HP-PR-CB19	JUNCTION	0.00	0.00	115.20	0	01:38	0.00
HP-PR-CB20	JUNCTION	0.00	0.00	115.20	0	01:40	0.00
HP-PR-CB21	JUNCTION	0.00	0.00	115.40	0	01:30	0.00
HP-PR-CB22	JUNCTION	0.00	0.01	115.41	0	01:30	0.01
HP-PR-CB23	JUNCTION	0.00	0.01	115.41	0	01:20	0.01
HP-PR-CB24a	JUNCTION	0.00	0.00	115.85	0	00:00	0.00
HP-PR-CB24b	JUNCTION	0.00	0.00	115.85	0	00:00	0.00
HP-PR-CB25a	JUNCTION	0.00	0.00	115.85	0	00:00	0.00
HP-PR-CB25b	JUNCTION	0.00	0.00	115.85	0	00:00	0.00
HP-PR-CB26a	JUNCTION	0.00	0.00	115.85	0	00:00	0.00
HP-PR-CB26b	JUNCTION	0.00	0.00	115.85	0	00:00	0.00
HP-PR-CB27a	JUNCTION	0.00	0.00	116.20	0	00:00	0.00
HP-PR-CB27b	JUNCTION	0.00	0.00	116.20	0	00:00	0.00
HP-PR-CB28a	JUNCTION	0.00	0.00	116.20	0	00:00	0.00
HP-PR-CB28b	JUNCTION	0.00	0.00	116.20	0	00:00	0.00
HP-PR-CB29	JUNCTION	0.00	0.00	112.95	0	00:00	0.00
HP-PR-CB34	JUNCTION	0.00	0.00	113.75	0	00:00	0.00
HP-PR-CB35	JUNCTION	0.00	0.00	113.75	0	00:00	0.00
HP-PR-CB36	JUNCTION	0.00	0.00	113.66	0	00:00	0.00
HP-PR-CB40	JUNCTION	0.00	0.00	113.25	0	00:00	0.00
HP-PR-CBMH104	JUNCTION	0.00	0.00	113.75	0	00:00	0.00

HP-PR-CBMH105	JUNCTION	0.00	0.00	113.70	0	00:00	0.00
HP-PR-CBMH106	JUNCTION	0.00	0.00	113.80	0	00:00	0.00
HP-PR-CBMH107	JUNCTION	0.00	0.00	113.70	0	01:29	0.00
HP-PR-CBMH108a	JUNCTION	0.00	0.00	113.85	0	00:00	0.00
HP-PR-CBMH108b	JUNCTION	0.00	0.00	113.85	0	00:00	0.00
HP-PR-CBMH109	JUNCTION	0.00	0.00	113.90	0	00:00	0.00
HP-PR-CBMH110	JUNCTION	0.00	0.06	113.66	0	01:20	0.05
HP-PR-CBMH111	JUNCTION	0.00	0.00	115.20	0	01:37	0.00
HP-PR-CBMH112	JUNCTION	0.00	0.00	115.40	0	01:31	0.00
HP-PR-CBMH114	JUNCTION	0.00	0.00	115.85	0	00:00	0.00
HP-PR-CBMH115	JUNCTION	0.00	0.00	116.20	0	00:00	0.00
HP-PR-CBMH124	JUNCTION	0.00	0.00	113.35	0	00:00	0.00
HP-PR-TD02	JUNCTION	0.00	0.00	113.30	0	00:00	0.00
HP-EX-CB14	OUTFALL	0.00	0.00	114.10	0	00:00	0.00
HP-EX-MH116	OUTFALL	0.00	0.02	106.86	0	01:50	0.02
HP-PR-CB11	OUTFALL	0.00	0.00	113.85	0	00:00	0.00
HP-PR-CB30	OUTFALL	0.00	0.00	112.65	0	00:00	0.00
HP-PR-CB31	OUTFALL	0.00	0.00	112.65	0	00:00	0.00
HP-PR-CB32	OUTFALL	0.00	0.01	113.01	0	01:14	0.01
HP-PR-CBMH118	OUTFALL	0.00	0.00	112.65	0	00:00	0.00
IF-EX-CB116	OUTFALL	0.00	0.00	112.99	0	00:00	0.00
IF-EX-CB117	OUTFALL	0.00	0.00	112.09	0	00:00	0.00
IF-EX-CB128	OUTFALL	0.00	0.00	112.51	0	00:00	0.00
IF-EX-CB137	OUTFALL	0.00	0.00	112.00	0	00:00	0.00
IF-EX-CB14	OUTFALL	0.00	0.00	111.19	0	00:00	0.00
IF-EX-CB28	OUTFALL	0.00	0.00	112.43	0	00:00	0.00
IF-EX-CB30	OUTFALL	0.00	0.00	112.50	0	00:00	0.00
IF-EX-CB50	OUTFALL	0.00	0.00	112.34	0	00:00	0.00
IF-EX-CB52	OUTFALL	0.00	0.00	112.44	0	00:00	0.00
IF-EX-CB54	OUTFALL	0.00	0.00	112.52	0	00:00	0.00
IF-EX-CB58	OUTFALL	0.00	0.00	112.44	0	00:00	0.00
IF-EX-CB64	OUTFALL	0.00	0.00	112.10	0	00:00	0.00
IF-EX-CB82	OUTFALL	0.00	0.00	112.62	0	00:00	0.00
IF-EX-CB84	OUTFALL	0.00	0.00	112.12	0	00:00	0.00
IF-EX-CB87	OUTFALL	0.00	0.00	112.50	0	00:00	0.00
IF-EX-CB90	OUTFALL	0.00	0.00	112.51	0	00:00	0.00
IF-EX-CB92	OUTFALL	0.00	0.00	112.49	0	00:00	0.00
IF-EX-CB95	OUTFALL	0.00	0.00	112.45	0	00:00	0.00
IF-EX-CB96	OUTFALL	0.00	0.00	112.22	0	00:00	0.00
IF-PR-CB04	OUTFALL	0.00	0.00	111.80	0	00:00	0.00
IF-PR-CB13	OUTFALL	0.00	0.00	111.90	0	00:00	0.00

4837 Albion Road - Hard Rock Ottawa (116111)  
 PCSWMM Model Output - Pr. Conditions (100-year, 3-hour Chicago Storm)

IF-PR-CB14	OUTFALL	0.00	0.00	111.80	0	00:00	0.00
IF-PR-CB18	OUTFALL	0.00	0.00	113.49	0	00:00	0.00
IF-PR-CB29	OUTFALL	0.00	0.00	111.10	0	00:00	0.00
IF-PR-CB32	OUTFALL	0.00	0.00	110.65	0	00:00	0.00
IF-PR-CB36	OUTFALL	0.00	0.00	111.85	0	00:00	0.00
IF-PR-CB40	OUTFALL	0.00	0.00	111.50	0	00:00	0.00
IF-PR-CBMH104	OUTFALL	0.00	0.00	112.04	0	00:00	0.00
IF-PR-CBMH105	OUTFALL	0.00	0.00	111.85	0	00:00	0.00
IF-PR-CBMH106	OUTFALL	0.00	0.00	112.01	0	00:00	0.00
IF-PR-CBMH107	OUTFALL	0.00	0.00	111.84	0	00:00	0.00
IF-PR-CBMH108	OUTFALL	0.00	0.00	112.01	0	00:00	0.00
IF-PR-CBMH109	OUTFALL	0.00	0.00	111.96	0	00:00	0.00
IF-PR-CBMH110	OUTFALL	0.00	0.00	111.62	0	00:00	0.00
IF-PR-CBMH111	OUTFALL	0.00	0.00	113.00	0	00:00	0.00
IF-PR-CBMH112	OUTFALL	0.00	0.00	113.12	0	00:00	0.00
IF-PR-CBMH114	OUTFALL	0.00	0.00	113.51	0	00:00	0.00
IF-PR-CBMH115	OUTFALL	0.00	0.00	113.89	0	00:00	0.00
IF-PR-CBMH118	OUTFALL	0.00	0.00	110.74	0	00:00	0.00
Major-01	OUTFALL	0.00	0.00	112.87	0	00:00	0.00
SWM_Pond	OUTFALL	0.08	0.47	103.42	0	01:20	0.47
EX-BLDG01	STORAGE	0.00	0.11	120.11	0	01:16	0.11
EX-CB116	STORAGE	0.03	0.54	113.53	0	01:25	0.54
EX-CB117	STORAGE	0.10	1.44	113.53	0	01:25	1.44
EX-CB128	STORAGE	0.09	1.31	113.82	0	01:21	1.31
EX-CB134	STORAGE	0.03	1.81	113.41	0	01:03	1.81
EX-CB137	STORAGE	0.03	1.58	113.58	0	01:11	1.58
EX-CB14	STORAGE	0.39	2.89	114.08	0	01:42	2.89
EX-CB28	STORAGE	0.11	1.42	113.85	0	01:37	1.42
EX-CB30	STORAGE	0.10	1.38	113.88	0	01:24	1.38
EX-CB50	STORAGE	0.07	1.49	113.83	0	01:12	1.49
EX-CB52	STORAGE	0.06	1.44	113.88	0	01:21	1.44
EX-CB54	STORAGE	0.05	1.37	113.89	0	01:20	1.37
EX-CB58	STORAGE	0.05	1.39	113.83	0	01:11	1.39
EX-CB60	STORAGE	0.07	1.69	113.84	0	01:21	1.69
EX-CB62	STORAGE	0.05	1.21	113.85	0	01:21	1.21
EX-CB64	STORAGE	0.09	1.56	113.66	0	01:20	1.55
EX-CB72	STORAGE	0.04	1.70	112.88	0	01:11	1.70
EX-CB82	STORAGE	0.04	1.39	114.01	0	01:11	1.39
EX-CB84	STORAGE	0.05	1.66	113.78	0	01:11	1.66
EX-CB87	STORAGE	0.09	1.33	113.83	0	01:23	1.33
EX-CB90	STORAGE	0.09	1.35	113.86	0	01:11	1.35

EX-CB92	STORAGE	0.10	1.39	113.88	0	01:30	1.39
EX-CB95	STORAGE	0.10	1.36	113.81	0	01:30	1.36
EX-CB96	STORAGE	0.12	1.59	113.81	0	01:33	1.59
EX-MH101	STORAGE	0.08	0.47	105.04	0	01:20	0.47
EX-MH101A	STORAGE	0.08	0.48	107.66	0	01:23	0.48
EX-MH101B	STORAGE	0.07	0.41	105.74	0	01:23	0.41
EX-MH102	STORAGE	0.07	0.44	109.82	0	01:22	0.44
EX-MH102A	STORAGE	0.15	0.28	112.61	0	01:35	0.28
EX-MH103	STORAGE	0.00	0.07	110.78	0	01:12	0.07
EX-MH104	STORAGE	0.08	1.00	111.65	0	01:22	1.00
EX-MH105	STORAGE	0.20	2.39	113.67	0	01:24	2.39
EX-MH105a	STORAGE	0.03	0.40	111.68	0	01:22	0.40
EX-MH106	STORAGE	0.12	1.57	113.72	0	01:26	1.57
EX-MH106a	STORAGE	0.17	2.09	113.70	0	01:24	2.09
EX-MH107	STORAGE	0.12	1.50	113.85	0	01:34	1.50
EX-MH107a	STORAGE	0.13	1.59	113.79	0	01:31	1.59
EX-MH108	STORAGE	0.05	1.71	113.03	0	01:22	1.71
EX-MH109	STORAGE	0.11	1.53	112.51	0	01:22	1.53
EX-MH112	STORAGE	0.07	1.50	113.65	0	01:22	1.50
EX-MH112a	STORAGE	0.04	0.95	113.10	0	01:23	0.95
EX-MH115	STORAGE	0.08	0.98	106.03	0	01:22	0.98
EX-MH116	STORAGE	0.11	1.40	106.90	0	01:50	1.39
EX-STUB02	STORAGE	0.06	1.83	113.21	0	01:22	1.83
PR-BLDG01	STORAGE	0.01	0.15	120.15	0	01:31	0.15
PR-BLDG02	STORAGE	0.01	0.15	120.15	0	01:24	0.15
PR-CB01	STORAGE	0.19	1.18	113.58	0	01:45	1.18
PR-CB02	STORAGE	0.18	1.13	113.58	0	01:45	1.13
PR-CB02a	STORAGE	0.20	1.22	113.58	0	01:45	1.22
PR-CB03	STORAGE	0.19	1.18	113.58	0	01:44	1.18
PR-CB04	STORAGE	0.52	1.78	113.58	0	01:45	1.78
PR-CB05	STORAGE	0.14	1.16	113.61	0	01:37	1.16
PR-CB08	STORAGE	0.21	1.21	113.66	0	01:50	1.21
PR-CB09	STORAGE	0.24	1.30	113.75	0	01:52	1.30
PR-CB11	STORAGE	0.36	1.22	113.82	0	02:30	1.22
PR-CB12	STORAGE	0.44	1.40	113.82	0	02:30	1.40
PR-CB13	STORAGE	0.10	1.83	113.73	0	01:08	1.83
PR-CB14	STORAGE	0.10	1.86	113.66	0	01:11	1.86
PR-CB15	STORAGE	0.22	1.45	113.65	0	01:35	1.45
PR-CB16/17	STORAGE	0.05	1.41	113.50	0	01:13	1.41
PR-CB18	STORAGE	0.09	1.70	115.19	0	01:13	1.70
PR-CB19	STORAGE	0.12	1.55	115.20	0	01:38	1.55



4837 Albion Road - Hard Rock Ottawa (116111)  
 PCSWMM Model Output - Pr. Conditions (100-year, 3-hour Chicago Storm)

PR-CB20	STORAGE	0.10	1.35	115.20	0	01:40	1.35
PR-CB21	STORAGE	0.38	1.84	115.40	0	01:30	1.84
PR-CB22	STORAGE	0.31	1.61	115.41	0	01:30	1.61
PR-CB23	STORAGE	0.27	1.41	115.41	0	01:20	1.41
PR-CB24	STORAGE	0.67	1.83	115.78	0	02:50	1.83
PR-CB25	STORAGE	0.57	1.64	115.78	0	02:50	1.64
PR-CB26	STORAGE	0.49	1.43	115.78	0	02:50	1.43
PR-CB27	STORAGE	0.37	1.58	116.09	0	02:11	1.58
PR-CB28	STORAGE	0.32	1.39	116.09	0	02:11	1.39
PR-CB29	STORAGE	0.14	0.74	111.84	0	01:43	0.74
PR-CB30	STORAGE	0.07	1.24	112.64	0	01:30	1.24
PR-CB31	STORAGE	0.09	1.44	112.64	0	01:30	1.44
PR-CB32	STORAGE	0.20	2.36	113.01	0	01:14	2.36
PR-CB35	STORAGE	0.15	1.51	113.71	0	01:29	1.51
PR-CB36	STORAGE	0.15	1.74	113.59	0	01:22	1.74
PR-CB37	STORAGE	0.19	1.22	113.67	0	01:34	1.22
PR-CB38	STORAGE	0.18	1.15	113.63	0	01:43	1.15
PR-CB39	STORAGE	0.15	0.98	113.63	0	01:44	0.98
PR-CB40	STORAGE	0.15	1.73	113.23	0	01:30	1.73
PR-CB41	STORAGE	0.04	1.47	112.77	0	01:11	1.47
PR-CBMH104	STORAGE	0.25	1.57	113.61	0	01:35	1.57
PR-CBMH105	STORAGE	0.43	1.78	113.63	0	01:43	1.78
PR-CBMH106	STORAGE	0.35	1.65	113.66	0	01:50	1.65
PR-CBMH107	STORAGE	0.26	1.86	113.70	0	01:29	1.86
PR-CBMH108	STORAGE	0.39	1.74	113.75	0	01:51	1.74
PR-CBMH109	STORAGE	0.69	1.85	113.81	0	02:30	1.85
PR-CBMH109a	STORAGE	0.04	0.46	112.67	0	01:23	0.46
PR-CBMH110	STORAGE	0.43	2.04	113.66	0	01:20	2.03
PR-CBMH111	STORAGE	0.27	2.20	115.20	0	01:37	2.20
PR-CBMH112	STORAGE	0.58	2.28	115.40	0	01:31	2.28
PR-CBMH114	STORAGE	0.96	2.27	115.78	0	02:50	2.27
PR-CBMH115	STORAGE	0.63	2.19	116.08	0	02:10	2.19
PR-CBMH115a	STORAGE	0.02	0.07	114.21	0	02:11	0.07
PR-CBMH118	STORAGE	0.16	1.89	112.63	0	01:21	1.89
PR-CBMH122	STORAGE	0.21	1.28	113.63	0	01:35	1.28
PR-MH100	STORAGE	0.24	1.42	113.58	0	01:45	1.42
PR-MH100a	STORAGE	0.03	0.53	112.69	0	01:24	0.53
PR-MH101	STORAGE	0.05	0.73	112.69	0	01:24	0.72
PR-MH102	STORAGE	0.08	0.97	112.67	0	01:24	0.97
PR-MH103	STORAGE	0.09	1.36	112.64	0	01:23	1.36
PR-MH104	STORAGE	0.10	1.48	112.58	0	01:22	1.48

PR-MH113	STORAGE	0.05	0.13	113.39	0	02:11	0.13
PR-MH116	STORAGE	0.03	0.72	111.37	0	01:22	0.72
PR-MH117	STORAGE	0.05	0.95	111.86	0	01:24	0.95
PR-MH119	STORAGE	0.06	0.17	113.15	0	01:34	0.17
PR-MH120	STORAGE	0.05	0.10	113.78	0	02:26	0.10
PR-MH123	STORAGE	0.03	0.82	111.94	0	01:24	0.82
PR-OGS1	STORAGE	0.02	0.64	112.02	0	01:24	0.64
PR-STUB01	STORAGE	0.01	0.21	111.47	0	01:22	0.21
PR-TD02	STORAGE	0.03	1.13	112.78	0	01:11	1.13
PR-TD1	STORAGE	0.40	0.77	112.67	0	01:24	0.77

\*\*\*\*\*  
 Node Inflow Summary  
 \*\*\*\*\*

Node	Type	Maximum	Maximum	Time of Max Occurrence days hr:min	Lateral	Total	Flow
		Lateral Inflow LPS	Total Inflow LPS		Inflow Volume 10^6 ltr	Inflow Volume 10^6 ltr	Balance Error Percent
HP-01	JUNCTION	0.00	16.68	0 01:38	0	0.0114	-0.001
HP-EX-CB116	JUNCTION	0.00	0.00	0 00:00	0	0	0.000 ltr
HP-EX-CB117	JUNCTION	0.00	0.00	0 00:00	0	0	0.000 ltr
HP-EX-CB128a	JUNCTION	0.00	0.00	0 00:00	0	0	0.000 ltr
HP-EX-CB128b	JUNCTION	0.00	0.00	0 00:00	0	0	0.000 ltr
HP-EX-CB131	JUNCTION	0.00	0.00	0 00:00	0	0	0.000 ltr
HP-EX-CB134	JUNCTION	0.00	15.62	0 01:03	0	0.00543	-0.032
HP-EX-CB137	JUNCTION	0.00	0.00	0 00:00	0	0	0.000 ltr
HP-EX-CB28	JUNCTION	0.00	0.00	0 00:00	0	0	0.000 ltr
HP-EX-CB30a	JUNCTION	0.00	0.00	0 00:00	0	0	0.000 ltr
HP-EX-CB30b	JUNCTION	0.00	0.00	0 00:00	0	0	0.000 ltr
HP-EX-CB50a	JUNCTION	0.00	0.00	0 00:00	0	0	0.000 ltr
HP-EX-CB50b	JUNCTION	0.00	0.00	0 00:00	0	0	0.000 ltr
HP-EX-CB52	JUNCTION	0.00	0.00	0 00:00	0	0	0.000 ltr
HP-EX-CB54	JUNCTION	0.00	0.00	0 00:00	0	0	0.000 ltr
HP-EX-CB58a	JUNCTION	0.00	0.00	0 00:00	0	0	0.000 ltr
HP-EX-CB58b	JUNCTION	0.00	0.00	0 00:00	0	0	0.000 ltr
HP-EX-CB60	JUNCTION	0.00	0.00	0 00:00	0	0	0.000 ltr
HP-EX-CB62	JUNCTION	0.00	0.00	0 00:00	0	0	0.000 ltr

4837 Albion Road - Hard Rock Ottawa (116111)  
 PCSWMM Model Output - Pr. Conditions (100-year, 3-hour Chicago Storm)

HP-EX-CB64	JUNCTION	0.00	12.65	0	01:20	0	0.000617	-0.381
HP-EX-CB72	JUNCTION	0.00	0.00	0	00:00	0	0	0.000 ltr
HP-EX-CB82	JUNCTION	0.00	0.00	0	00:00	0	0	0.000 ltr
HP-EX-CB84	JUNCTION	0.00	0.00	0	00:00	0	0	0.000 ltr
HP-EX-CB87a	JUNCTION	0.00	0.00	0	00:00	0	0	0.000 ltr
HP-EX-CB87b	JUNCTION	0.00	0.00	0	00:00	0	0	0.000 ltr
HP-EX-CB90	JUNCTION	0.00	0.00	0	00:00	0	0	0.000 ltr
HP-EX-CB92	JUNCTION	0.00	0.00	0	00:00	0	0	0.000 ltr
HP-EX-CB95	JUNCTION	0.00	0.00	0	00:00	0	0	0.000 ltr
HP-EX-CB96	JUNCTION	0.00	0.00	0	00:00	0	0	0.000 ltr
HP-PR-CB01	JUNCTION	0.00	0.00	0	00:00	0	0	0.000 ltr
HP-PR-CB02	JUNCTION	0.00	0.00	0	00:00	0	0	0.000 ltr
HP-PR-CB03	JUNCTION	0.00	0.00	0	00:00	0	0	0.000 ltr
HP-PR-CB04	JUNCTION	0.00	0.00	0	00:00	0	0	0.000 ltr
HP-PR-CB05	JUNCTION	0.00	0.00	0	00:00	0	0	0.000 ltr
HP-PR-CB06	JUNCTION	0.00	0.00	0	00:00	0	0	0.000 ltr
HP-PR-CB07	JUNCTION	0.00	0.00	0	00:00	0	0	0.000 ltr
HP-PR-CB08	JUNCTION	0.00	0.00	0	00:00	0	0	0.000 ltr
HP-PR-CB09	JUNCTION	0.00	0.00	0	00:00	0	0	0.000 ltr
HP-PR-CB12	JUNCTION	0.00	0.00	0	00:00	0	0	0.000 ltr
HP-PR-CB13	JUNCTION	0.00	17.64	0	01:09	0	0.00426	0.920
HP-PR-CB14	JUNCTION	0.00	9.47	0	01:11	0	0.00329	-0.016
HP-PR-CB15	JUNCTION	0.00	0.00	0	00:00	0	0	0.000 ltr
HP-PR-CB16/17	JUNCTION	0.00	0.00	0	00:00	0	0	0.000 ltr
HP-PR-CB18	JUNCTION	0.00	0.00	0	00:00	0	0	0.000 ltr
HP-PR-CB19	JUNCTION	0.00	6.96	0	01:38	0	0.0041	0.010
HP-PR-CB20	JUNCTION	0.00	8.43	0	01:40	0	0.00694	0.006
HP-PR-CB21	JUNCTION	0.00	8.25	0	01:30	0	0.00923	0.001
HP-PR-CB22	JUNCTION	0.00	10.80	0	01:30	0	0.0183	0.115
HP-PR-CB23	JUNCTION	0.00	17.11	0	01:20	0	0.0262	0.098
HP-PR-CB24a	JUNCTION	0.00	0.00	0	00:00	0	0	0.000 ltr
HP-PR-CB24b	JUNCTION	0.00	0.00	0	00:00	0	0	0.000 ltr
HP-PR-CB25a	JUNCTION	0.00	0.00	0	00:00	0	0	0.000 ltr
HP-PR-CB25b	JUNCTION	0.00	0.00	0	00:00	0	0	0.000 ltr
HP-PR-CB26a	JUNCTION	0.00	0.00	0	00:00	0	0	0.000 ltr
HP-PR-CB26b	JUNCTION	0.00	0.00	0	00:00	0	0	0.000 ltr
HP-PR-CB27a	JUNCTION	0.00	0.00	0	00:00	0	0	0.000 ltr
HP-PR-CB27b	JUNCTION	0.00	0.00	0	00:00	0	0	0.000 ltr
HP-PR-CB28a	JUNCTION	0.00	0.00	0	00:00	0	0	0.000 ltr
HP-PR-CB28b	JUNCTION	0.00	0.00	0	00:00	0	0	0.000 ltr
HP-PR-CB29	JUNCTION	0.00	0.00	0	00:00	0	0	0.000 ltr

HP-PR-CB34	JUNCTION	0.00	0.00	0	00:00	0	0	0.000 ltr
HP-PR-CB35	JUNCTION	0.00	0.00	0	00:00	0	0	0.000 ltr
HP-PR-CB36	JUNCTION	0.00	0.00	0	00:00	0	0	0.000 ltr
HP-PR-CB40	JUNCTION	0.00	0.00	0	00:00	0	0	0.000 ltr
HP-PR-CBMH104	JUNCTION	0.00	0.00	0	00:00	0	0	0.000 ltr
HP-PR-CBMH105	JUNCTION	0.00	0.00	0	00:00	0	0	0.000 ltr
HP-PR-CBMH106	JUNCTION	0.00	0.00	0	00:00	0	0	0.000 ltr
HP-PR-CBMH107	JUNCTION	0.00	6.51	0	01:29	0	0.00135	0.016
HP-PR-CBMH108a	JUNCTION	0.00	0.00	0	00:00	0	0	0.000 ltr
HP-PR-CBMH108b	JUNCTION	0.00	0.00	0	00:00	0	0	0.000 ltr
HP-PR-CBMH109	JUNCTION	0.00	0.00	0	00:00	0	0	0.000 ltr
HP-PR-CBMH110	JUNCTION	0.00	31.18	0	01:19	0	0.0357	-0.008
HP-PR-CBMH111	JUNCTION	0.00	2.16	0	01:37	0	0.000345	0.084
HP-PR-CBMH112	JUNCTION	0.00	2.57	0	01:31	0	0.000965	-0.382
HP-PR-CBMH114	JUNCTION	0.00	0.00	0	00:00	0	0	0.000 ltr
HP-PR-CBMH115	JUNCTION	0.00	0.00	0	00:00	0	0	0.000 ltr
HP-PR-CBMH124	JUNCTION	0.00	0.00	0	00:00	0	0	0.000 ltr
HP-PR-TD02	JUNCTION	0.00	0.00	0	00:00	0	0	0.000 ltr
HP-EX-CB14	OUTFALL	0.00	0.00	0	00:00	0	0	0.000 ltr
HP-EX-MH116	OUTFALL	0.00	42.25	0	01:50	0	0.124	0.000
HP-PR-CB11	OUTFALL	0.00	0.00	0	00:00	0	0	0.000 ltr
HP-PR-CB30	OUTFALL	0.00	0.00	0	00:00	0	0	0.000 ltr
HP-PR-CB31	OUTFALL	0.00	0.00	0	00:00	0	0	0.000 ltr
HP-PR-CB32	OUTFALL	0.00	19.03	0	01:14	0	0.00933	0.000
HP-PR-CBMH118	OUTFALL	0.00	0.00	0	00:00	0	0	0.000 ltr
IF-EX-CB116	OUTFALL	0.00	0.14	0	00:25	0	0.00162	0.000
IF-EX-CB117	OUTFALL	0.00	0.14	0	00:25	0	0.00169	0.000
IF-EX-CB128	OUTFALL	0.00	0.14	0	00:26	0	0.00177	0.000
IF-EX-CB137	OUTFALL	0.00	0.21	0	00:25	0	0.00252	0.000
IF-EX-CB14	OUTFALL	0.00	0.14	0	00:24	0	0.00311	0.000
IF-EX-CB28	OUTFALL	0.00	0.14	0	00:24	0	0.00184	0.000
IF-EX-CB30	OUTFALL	0.00	0.14	0	00:25	0	0.00193	0.000
IF-EX-CB50	OUTFALL	0.00	0.14	0	00:24	0	0.00201	0.000
IF-EX-CB52	OUTFALL	0.00	0.14	0	00:25	0	0.00189	0.000
IF-EX-CB54	OUTFALL	0.00	0.14	0	00:25	0	0.00162	0.000
IF-EX-CB58	OUTFALL	0.00	0.14	0	00:25	0	0.00183	0.000
IF-EX-CB64	OUTFALL	0.00	0.14	0	00:25	0	0.00158	0.000
IF-EX-CB82	OUTFALL	0.00	0.21	0	00:25	0	0.00321	0.000
IF-EX-CB84	OUTFALL	0.00	0.21	0	00:25	0	0.00264	0.000
IF-EX-CB87	OUTFALL	0.00	0.14	0	00:25	0	0.00183	0.000
IF-EX-CB90	OUTFALL	0.00	0.14	0	00:25	0	0.00174	0.000

4837 Albion Road - Hard Rock Ottawa (116111)  
 PCSWMM Model Output - Pr. Conditions (100-year, 3-hour Chicago Storm)

IF-EX-CB92	OUTFALL	0.00	0.14	0	00:25	0	0.00198	0.000
IF-EX-CB95	OUTFALL	0.00	0.14	0	00:26	0	0.00182	0.000
IF-EX-CB96	OUTFALL	0.00	0.14	0	00:24	0	0.00181	0.000
IF-PR-CB04	OUTFALL	0.00	0.39	0	00:25	0	0.0246	0.000
IF-PR-CB13	OUTFALL	0.00	0.15	0	00:25	0	0.0027	0.000
IF-PR-CB14	OUTFALL	0.00	0.15	0	00:26	0	0.00265	0.000
IF-PR-CB18	OUTFALL	0.00	0.15	0	00:25	0	0.00265	0.000
IF-PR-CB29	OUTFALL	0.00	1.17	0	00:28	0	0.032	0.000
IF-PR-CB32	OUTFALL	0.00	1.61	0	00:28	0	0.0434	0.000
IF-PR-CB36	OUTFALL	0.00	0.15	0	00:25	0	0.00362	0.000
IF-PR-CB40	OUTFALL	0.00	1.17	0	00:27	0	0.0148	0.000
IF-PR-CBMH104	OUTFALL	0.00	0.15	0	00:25	0	0.00478	0.000
IF-PR-CBMH105	OUTFALL	0.00	0.27	0	00:25	0	0.014	0.000
IF-PR-CBMH106	OUTFALL	0.00	0.52	0	00:26	0	0.0181	0.000
IF-PR-CBMH107	OUTFALL	0.00	0.21	0	00:24	0	0.00742	0.000
IF-PR-CBMH108	OUTFALL	0.00	0.58	0	00:26	0	0.0214	0.000
IF-PR-CBMH109	OUTFALL	0.00	1.55	0	00:26	0	0.0891	0.000
IF-PR-CBMH110	OUTFALL	0.00	1.24	0	00:26	0	0.053	0.000
IF-PR-CBMH111	OUTFALL	0.00	0.94	0	00:27	0	0.0282	0.000
IF-PR-CBMH112	OUTFALL	0.00	2.18	0	00:28	0	0.106	0.000
IF-PR-CBMH114	OUTFALL	0.00	2.18	0	00:27	0	0.145	0.000
IF-PR-CBMH115	OUTFALL	0.00	1.24	0	00:27	0	0.0602	0.000
IF-PR-CBMH118	OUTFALL	0.00	2.28	0	00:28	0	0.0489	0.000
Major-01	OUTFALL	0.00	0.00	0	00:00	0	0	0.000 ltr
SWM_Pond	OUTFALL	0.00	1139.63	0	01:20	0	8.19	0.000
EX-BLDG01	STORAGE	412.65	412.65	0	01:10	0.618	0.618	-0.007
EX-CB116	STORAGE	24.80	53.27	0	01:02	0.0351	0.0378	-0.145
EX-CB117	STORAGE	46.74	68.50	0	01:05	0.0601	0.097	-0.063
EX-CB128	STORAGE	33.71	89.60	0	01:03	0.0494	0.0532	-0.327
EX-CB134	STORAGE	32.24	32.24	0	01:10	0.0456	0.0456	-0.005
EX-CB137	STORAGE	77.94	77.94	0	01:10	0.0975	0.0975	-0.152
EX-CB14	STORAGE	513.32	513.32	0	01:10	0.699	0.71	-0.017
EX-CB28	STORAGE	111.69	111.69	0	01:10	0.154	0.155	0.136
EX-CB30	STORAGE	142.93	142.93	0	01:10	0.187	0.187	-0.039
EX-CB50	STORAGE	124.00	168.64	0	01:03	0.175	0.366	0.007
EX-CB52	STORAGE	97.61	146.16	0	01:03	0.135	0.196	-0.082
EX-CB54	STORAGE	46.25	114.47	0	01:02	0.0574	0.0605	-1.060
EX-CB58	STORAGE	75.24	75.24	0	01:10	0.106	0.106	0.038
EX-CB60	STORAGE	56.76	66.29	0	01:10	0.078	0.124	0.052
EX-CB62	STORAGE	31.10	31.10	0	01:10	0.0462	0.0462	0.107
EX-CB64	STORAGE	38.89	49.58	0	01:18	0.05	0.0753	-0.254

EX-CB72	STORAGE	23.79	23.79	0	01:10	0.0302	0.0302	0.038
EX-CB82	STORAGE	195.65	195.65	0	01:10	0.271	0.271	-0.358
EX-CB84	STORAGE	81.35	81.35	0	01:10	0.113	0.113	-0.495
EX-CB87	STORAGE	105.23	105.23	0	01:10	0.136	0.136	-0.451
EX-CB90	STORAGE	74.45	74.45	0	01:10	0.103	0.103	-0.029
EX-CB92	STORAGE	127.70	127.70	0	01:10	0.167	0.167	-0.263
EX-CB95	STORAGE	32.81	92.11	0	01:02	0.0464	0.106	-0.205
EX-CB96	STORAGE	92.08	130.99	0	01:04	0.129	0.23	-0.177
EX-MH101	STORAGE	94.60	1139.58	0	01:20	0.181	8.19	-0.002
EX-MH101A	STORAGE	0.00	967.49	0	01:23	0	7.15	-0.000
EX-MH101B	STORAGE	0.00	967.51	0	01:23	0	7.15	0.012
EX-MH102	STORAGE	0.00	910.13	0	01:22	0	6.44	-0.000
EX-MH102A	STORAGE	0.00	59.06	0	01:34	0	1.22	0.006
EX-MH103	STORAGE	0.00	11.58	0	01:11	0	0.0302	-0.004
EX-MH104	STORAGE	46.89	841.15	0	01:20	0.0578	5.19	0.040
EX-MH105	STORAGE	0.00	131.85	0	01:03	0	0.961	0.001
EX-MH105a	STORAGE	0.00	122.26	0	01:34	0	0.961	-0.004
EX-MH106	STORAGE	0.00	134.36	0	01:03	0	0.724	-0.011
EX-MH106a	STORAGE	0.00	191.87	0	01:03	0	0.961	-0.022
EX-MH107	STORAGE	0.00	181.35	0	01:02	0	0.338	-0.062
EX-MH107a	STORAGE	0.00	184.34	0	01:04	0	0.724	0.011
EX-MH108	STORAGE	28.79	195.38	0	01:10	0.037	0.655	-0.014
EX-MH109	STORAGE	0.00	584.39	0	01:22	0	3.79	-0.177
EX-MH112	STORAGE	0.00	142.18	0	01:03	0	0.468	0.005
EX-MH112a	STORAGE	0.00	116.78	0	01:03	0	0.468	0.069
EX-MH115	STORAGE	0.00	103.90	0	01:09	0	0.859	-0.038
EX-MH116	STORAGE	0.00	138.87	0	01:09	0	0.982	-0.113
EX-STUB02	STORAGE	0.00	178.60	0	01:11	0	0.618	0.020
PR-BLDG01	STORAGE	475.44	475.44	0	01:10	0.706	0.706	0.010
PR-BLDG02	STORAGE	197.33	197.33	0	01:10	0.287	0.287	0.012
PR-CB01	STORAGE	32.09	46.07	0	01:05	0.0388	0.0397	0.245
PR-CB02	STORAGE	20.45	21.45	0	01:05	0.0272	0.0285	-0.069
PR-CB02a	STORAGE	0.00	47.65	0	01:04	0	0.0701	0.037
PR-CB03	STORAGE	33.30	37.38	0	01:04	0.0376	0.0377	-0.072
PR-CB04	STORAGE	44.06	99.12	0	01:03	0.062	0.0769	-0.687
PR-CB05	STORAGE	41.17	56.62	0	01:04	0.0583	0.0613	0.331
PR-CB08	STORAGE	51.09	72.74	0	01:05	0.0723	0.0863	0.426
PR-CB09	STORAGE	56.05	74.67	0	01:04	0.0793	0.089	0.429
PR-CB11	STORAGE	73.41	73.41	0	01:10	0.104	0.105	0.107
PR-CB12	STORAGE	98.70	123.85	0	01:01	0.14	0.245	0.350
PR-CB13	STORAGE	25.79	25.79	0	01:10	0.0365	0.0365	-0.043

4837 Albion Road - Hard Rock Ottawa (116111)  
 PCSWMM Model Output - Pr. Conditions (100-year, 3-hour Chicago Storm)

PR-CB14	STORAGE	22.98	40.61	0	01:10	0.0284	0.0338	-0.052
PR-CB15	STORAGE	59.45	99.29	0	01:08	0.0797	0.0928	-0.415
PR-CB16/17	STORAGE	216.43	216.43	0	01:10	0.279	0.279	-0.140
PR-CB18	STORAGE	27.96	27.96	0	01:10	0.0365	0.0375	0.059
PR-CB19	STORAGE	31.56	95.73	0	01:10	0.0417	0.143	0.698
PR-CB20	STORAGE	41.66	57.99	0	01:10	0.059	0.0873	-0.126
PR-CB21	STORAGE	82.30	183.45	0	01:03	0.116	0.339	0.211
PR-CB22	STORAGE	81.31	143.89	0	01:02	0.115	0.24	0.283
PR-CB23	STORAGE	106.11	106.11	0	01:10	0.15	0.15	0.070
PR-CB24	STORAGE	87.77	184.75	0	01:03	0.124	0.417	0.232
PR-CB25	STORAGE	87.77	146.83	0	01:02	0.124	0.29	-0.057
PR-CB26	STORAGE	116.53	116.53	0	01:10	0.165	0.165	0.131
PR-CB27	STORAGE	78.85	121.08	0	01:02	0.112	0.221	0.229
PR-CB28	STORAGE	76.87	76.87	0	01:10	0.109	0.109	-0.021
PR-CB29	STORAGE	58.03	58.03	0	01:10	0.0821	0.0841	-0.190
PR-CB30	STORAGE	45.63	63.50	0	01:08	0.0646	0.0733	0.085
PR-CB31	STORAGE	97.55	136.43	0	01:06	0.138	0.223	0.400
PR-CB32	STORAGE	75.36	89.76	0	01:08	0.107	0.114	-0.517
PR-CB35	STORAGE	16.87	52.99	0	01:05	0.0206	0.0243	0.137
PR-CB36	STORAGE	25.33	25.33	0	01:10	0.0305	0.0305	0.057
PR-CB37	STORAGE	15.81	26.35	0	01:04	0.0222	0.025	2.272
PR-CB38	STORAGE	24.95	43.91	0	01:04	0.0324	0.0417	-0.104
PR-CB39	STORAGE	4.96	20.56	0	01:04	0.00702	0.00773	0.054
PR-CB40	STORAGE	68.73	68.73	0	01:10	0.0941	0.0941	-1.964
PR-CB41	STORAGE	14.38	14.38	0	01:10	0.0204	0.0204	0.112
PR-CBMH104	STORAGE	27.42	61.98	0	01:03	0.0352	0.0963	-0.084
PR-CBMH105	STORAGE	18.23	72.78	0	01:03	0.0226	0.14	-0.196
PR-CBMH106	STORAGE	57.30	104.75	0	01:03	0.08	0.166	-0.098
PR-CBMH107	STORAGE	65.68	99.06	0	01:05	0.0834	0.108	0.119
PR-CBMH108	STORAGE	65.47	116.90	0	01:03	0.0926	0.181	-0.176
PR-CBMH109	STORAGE	108.62	198.88	0	01:04	0.154	0.397	-0.996
PR-CBMH109a	STORAGE	0.00	20.00	0	01:12	0	0.312	0.000
PR-CBMH110	STORAGE	111.03	191.49	0	01:07	0.146	0.248	-0.161
PR-CBMH111	STORAGE	31.56	104.05	0	01:06	0.0417	0.186	-0.516
PR-CBMH112	STORAGE	82.80	250.99	0	01:06	0.117	0.445	-1.132
PR-CBMH114	STORAGE	106.12	272.31	0	01:05	0.15	0.565	-0.212
PR-CBMH115	STORAGE	76.87	174.61	0	01:05	0.109	0.329	-0.332
PR-CBMH115a	STORAGE	0.00	10.47	0	02:10	0	0.269	0.017
PR-CBMH118	STORAGE	140.35	264.15	0	01:05	0.199	0.413	-1.518
PR-CBMH122	STORAGE	42.87	69.02	0	01:05	0.0539	0.12	0.287
PR-MH100	STORAGE	0.00	86.78	0	01:03	0	0.158	0.302

PR-MH100a	STORAGE	0.00	24.33	0	01:12	0	0.256	0.090
PR-MH101	STORAGE	0.00	63.01	0	01:11	0	0.761	-0.048
PR-MH102	STORAGE	0.00	101.31	0	01:43	0	1.14	-0.212
PR-MH103	STORAGE	0.00	254.73	0	01:43	0	1.9	0.143
PR-MH104	STORAGE	0.00	280.24	0	01:42	0	1.96	-0.069
PR-MH113	STORAGE	0.00	35.90	0	02:10	0	1.03	-0.024
PR-MH116	STORAGE	0.00	149.48	0	01:09	0	0.983	0.047
PR-MH117	STORAGE	0.00	105.67	0	01:06	0	0.658	-0.002
PR-MH119	STORAGE	0.00	59.06	0	01:34	0	1.22	0.020
PR-MH120	STORAGE	0.00	21.24	0	02:25	0	0.688	-0.038
PR-MH123	STORAGE	0.00	55.18	0	01:06	0	0.239	-0.125
PR-OGS1	STORAGE	0.00	44.94	0	01:10	0	0.167	0.232
PR-STUB01	STORAGE	0.00	37.90	0	01:20	0	0.287	0.046
PR-TD02	STORAGE	60.48	60.48	0	01:10	0.0856	0.0856	0.067
PR-TD1	STORAGE	8.93	9.11	0	01:14	0.0126	0.0129	2.907

\*\*\*\*\*  
 Node Surcharge Summary  
 \*\*\*\*\*

No nodes were surcharged.

\*\*\*\*\*  
 Node Flooding Summary  
 \*\*\*\*\*

No nodes were flooded.

\*\*\*\*\*  
 Storage Volume Summary  
 \*\*\*\*\*

Storage Unit	Average Volume 1000 m3	Avg Pcnt Full	Evap Pcnt Loss	Exfil Pcnt Loss	Maximum Volume 1000 m3	Max Pcnt Full	Time of Max Occurrence days hr:min	Maximum Outflow LPS
EX-BLDG01	0.004	0	0	0	0.162	4	0 01:16	178.60

4837 Albion Road - Hard Rock Ottawa (116111)  
 PCSWMM Model Output - Pr. Conditions (100-year, 3-hour Chicago Storm)

EX-CB116	0.000	2	0	0	0.007	34	0	01:25	29.24
EX-CB117	0.001	2	0	0	0.033	39	0	01:25	43.80
EX-CB128	0.001	3	0	0	0.012	51	0	01:21	21.05
EX-CB134	0.000	1	0	0	0.001	46	0	01:03	35.05
EX-CB137	0.000	2	0	0	0.015	86	0	01:11	47.49
EX-CB14	0.032	8	0	0	0.372	93	0	01:42	57.69
EX-CB28	0.005	2	0	0	0.085	35	0	01:37	95.30
EX-CB30	0.003	2	0	0	0.064	36	0	01:24	99.59
EX-CB50	0.001	0	0	0	0.035	20	0	01:12	104.30
EX-CB52	0.002	1	0	0	0.067	41	0	01:21	87.30
EX-CB54	0.000	1	0	0	0.011	24	0	01:20	53.16
EX-CB58	0.001	0	0	0	0.023	18	0	01:11	52.65
EX-CB60	0.000	1	0	0	0.017	41	0	01:21	31.55
EX-CB62	0.000	1	0	0	0.009	39	0	01:21	20.90
EX-CB64	0.001	2	0	0	0.008	37	0	01:20	38.87
EX-CB72	0.000	0	0	0	0.004	39	0	01:11	11.58
EX-CB82	0.001	1	0	0	0.057	63	0	01:11	96.52
EX-CB84	0.001	0	0	0	0.029	16	0	01:11	35.71
EX-CB87	0.002	1	0	0	0.048	35	0	01:23	50.24
EX-CB90	0.001	1	0	0	0.023	23	0	01:11	54.08
EX-CB92	0.004	3	0	0	0.071	58	0	01:30	52.52
EX-CB95	0.001	3	0	0	0.012	42	0	01:30	65.58
EX-CB96	0.003	2	0	0	0.074	33	0	01:33	87.56
EX-MH101	0.000	3	0	0	0.000	20	0	01:20	1139.63
EX-MH101A	0.000	2	0	0	0.000	10	0	01:23	967.51
EX-MH101B	0.000	1	0	0	0.000	8	0	01:23	967.51
EX-MH102	0.000	2	0	0	0.000	9	0	01:22	910.16
EX-MH102A	0.000	8	0	0	0.000	15	0	01:35	59.06
EX-MH103	0.000	0	0	0	0.000	3	0	01:12	11.57
EX-MH104	0.000	2	0	0	0.001	31	0	01:22	840.38
EX-MH105	0.000	7	0	0	0.002	87	0	01:24	122.26
EX-MH105a	0.000	1	0	0	0.000	15	0	01:22	124.53
EX-MH106	0.000	4	0	0	0.002	55	0	01:26	109.26
EX-MH106a	0.000	7	0	0	0.002	88	0	01:24	131.85
EX-MH107	0.000	5	0	0	0.002	58	0	01:34	96.43
EX-MH107a	0.000	5	0	0	0.002	57	0	01:31	134.36
EX-MH108	0.000	2	0	0	0.002	73	0	01:22	188.54
EX-MH109	0.000	4	0	0	0.002	58	0	01:22	586.90
EX-MH112	0.000	2	0	0	0.001	54	0	01:22	116.78
EX-MH112a	0.000	2	0	0	0.001	53	0	01:23	112.59
EX-MH115	0.000	4	0	0	0.001	54	0	01:22	100.32

EX-MH116	0.000	5	0	0	0.001	59	0	01:50	137.98
EX-STUB02	0.000	3	0	0	0.002	80	0	01:22	178.94
PR-BLDG01	0.027	1	0	0	0.358	8	0	01:31	76.26
PR-BLDG02	0.008	0	0	0	0.137	8	0	01:24	37.90
PR-CB01	0.001	7	0	0	0.014	72	0	01:45	20.81
PR-CB02	0.001	2	0	0	0.011	28	0	01:45	18.96
PR-CB02a	0.000	9	0	0	0.001	57	0	01:45	37.60
PR-CB03	0.001	4	0	0	0.010	47	0	01:44	36.38
PR-CB04	0.012	14	0	0	0.056	64	0	01:45	63.48
PR-CB05	0.002	3	0	0	0.026	42	0	01:37	38.11
PR-CB08	0.005	7	0	0	0.046	68	0	01:50	48.55
PR-CB09	0.006	7	0	0	0.047	62	0	01:52	52.62
PR-CB11	0.009	14	0	0	0.050	75	0	02:30	41.57
PR-CB12	0.013	12	0	0	0.071	64	0	02:30	94.57
PR-CB13	0.001	6	0	0	0.010	100	0	01:07	25.80
PR-CB14	0.001	5	0	0	0.012	100	0	01:11	17.17
PR-CB15	0.002	6	0	0	0.036	84	0	01:35	57.46
PR-CB16/17	0.001	0	0	0	0.052	24	0	01:13	97.00
PR-CB18	0.001	4	0	0	0.012	95	0	01:13	9.27
PR-CB19	0.000	3	0	0	0.007	97	0	01:38	72.82
PR-CB20	0.001	6	0	0	0.013	100	0	01:23	41.66
PR-CB21	0.005	12	0	0	0.038	99	0	01:30	169.67
PR-CB22	0.005	12	0	0	0.039	99	0	01:30	108.50
PR-CB23	0.004	13	0	0	0.033	100	0	01:20	71.96
PR-CB24	0.014	12	0	0	0.071	56	0	02:50	168.14
PR-CB25	0.014	12	0	0	0.069	57	0	02:50	106.40
PR-CB26	0.012	12	0	0	0.057	58	0	02:50	71.88
PR-CB27	0.007	6	0	0	0.050	40	0	02:11	99.82
PR-CB28	0.007	6	0	0	0.047	41	0	02:11	50.55
PR-CB29	0.008	8	0	0	0.060	60	0	01:43	5.53
PR-CB30	0.001	3	0	0	0.030	94	0	01:30	41.01
PR-CB31	0.002	3	0	0	0.051	92	0	01:30	128.74
PR-CB32	0.009	15	0	0	0.063	100	0	01:13	27.95
PR-CB35	0.000	4	0	0	0.003	100	0	01:23	38.94
PR-CB36	0.001	3	0	0	0.013	52	0	01:22	6.20
PR-CB37	0.001	9	0	0	0.010	100	0	01:30	20.04
PR-CB38	0.000	5	0	0	0.006	72	0	01:43	19.96
PR-CB39	0.000	1	0	0	0.000	4	0	01:44	10.73
PR-CB40	0.003	5	0	0	0.043	84	0	01:30	11.11
PR-CB41	0.000	0	0	0	0.003	3	0	01:11	7.60
PR-CBMH104	0.003	6	0	0	0.025	44	0	01:35	22.90

4837 Albion Road - Hard Rock Ottawa (116111)  
 PCSWMM Model Output - Pr. Conditions (100-year, 3-hour Chicago Storm)

PR-CBMH105	0.009	22	0	0	0.042	100	0	01:15	23.91
PR-CBMH106	0.009	8	0	0	0.049	41	0	01:50	29.47
PR-CBMH107	0.007	13	0	0	0.057	100	0	01:16	44.14
PR-CBMH108	0.012	11	0	0	0.064	58	0	01:51	26.93
PR-CBMH109	0.059	24	0	0	0.178	71	0	02:30	10.99
PR-CBMH109a	0.000	2	0	0	0.000	19	0	01:23	17.04
PR-CBMH110	0.027	22	0	0	0.122	100	0	01:18	54.72
PR-CBMH111	0.011	15	0	0	0.072	100	0	01:37	49.53
PR-CBMH112	0.053	28	0	0	0.187	99	0	01:31	24.19
PR-CBMH114	0.092	34	0	0	0.218	80	0	02:50	17.41
PR-CBMH115	0.036	18	0	0	0.128	64	0	02:10	11.71
PR-CBMH115a	0.000	1	0	0	0.000	2	0	02:11	10.47
PR-CBMH118	0.010	9	0	0	0.114	97	0	01:21	82.93
PR-CBMH122	0.002	9	0	0	0.022	100	0	01:29	57.93
PR-MH100	0.000	16	0	0	0.001	95	0	01:45	60.41
PR-MH100a	0.000	2	0	0	0.001	35	0	01:24	30.13
PR-MH101	0.000	3	0	0	0.001	41	0	01:24	79.39
PR-MH102	0.000	3	0	0	0.001	43	0	01:24	120.72
PR-MH103	0.000	4	0	0	0.001	54	0	01:23	269.21
PR-MH104	0.000	4	0	0	0.001	57	0	01:22	289.53
PR-MH113	0.000	3	0	0	0.000	6	0	02:11	35.90
PR-MH116	0.000	1	0	0	0.001	28	0	01:22	138.87
PR-MH117	0.000	3	0	0	0.001	50	0	01:24	98.19
PR-MH119	0.000	3	0	0	0.000	8	0	01:34	59.06
PR-MH120	0.000	2	0	0	0.000	5	0	02:26	21.24
PR-MH123	0.000	2	0	0	0.001	42	0	01:24	53.84
PR-OGS1	0.000	1	0	0	0.001	34	0	01:24	44.79
PR-STUB01	0.000	0	0	0	0.000	2	0	01:22	39.03
PR-TD02	0.000	0	0	0	0.012	3	0	01:11	35.43
PR-TD1	0.000	0	0	0	0.000	0	0	01:24	8.93

\*\*\*\*\*  
 Outfall Loading Summary  
 \*\*\*\*\*

Outfall Node	Flow Freq Pcnt	Avg Flow LPS	Max Flow LPS	Total Volume 10^6 ltr
--------------	----------------------	--------------------	--------------------	-----------------------------

HP-EX-CB14	0.00	0.00	0.00	0.000
HP-EX-MH116	5.34	27.80	42.25	0.124
HP-PR-CB11	0.00	0.00	0.00	0.000
HP-PR-CB30	0.00	0.00	0.00	0.000
HP-PR-CB31	0.00	0.00	0.00	0.000
HP-PR-CB32	1.44	7.60	19.03	0.009
HP-PR-CBMH118	0.00	0.00	0.00	0.000
IF-EX-CB116	14.74	0.13	0.14	0.002
IF-EX-CB117	15.56	0.13	0.14	0.002
IF-EX-CB128	16.76	0.12	0.14	0.002
IF-EX-CB137	15.61	0.19	0.21	0.003
IF-EX-CB14	32.72	0.11	0.14	0.003
IF-EX-CB28	17.14	0.13	0.14	0.002
IF-EX-CB30	18.46	0.12	0.14	0.002
IF-EX-CB50	18.64	0.13	0.14	0.002
IF-EX-CB52	17.77	0.12	0.14	0.002
IF-EX-CB54	14.73	0.13	0.14	0.002
IF-EX-CB58	17.23	0.12	0.14	0.002
IF-EX-CB64	14.19	0.13	0.14	0.002
IF-EX-CB82	21.43	0.18	0.21	0.003
IF-EX-CB84	16.64	0.19	0.21	0.003
IF-EX-CB87	17.27	0.12	0.14	0.002
IF-EX-CB90	16.16	0.13	0.14	0.002
IF-EX-CB92	19.09	0.12	0.14	0.002
IF-EX-CB95	17.47	0.12	0.14	0.002
IF-EX-CB96	16.81	0.13	0.14	0.002
IF-PR-CB04	73.21	0.39	0.39	0.025
IF-PR-CB13	21.12	0.15	0.15	0.003
IF-PR-CB14	20.69	0.15	0.15	0.003
IF-PR-CB18	20.72	0.15	0.15	0.003
IF-PR-CB29	32.08	1.16	1.17	0.032
IF-PR-CB32	31.73	1.59	1.61	0.043
IF-PR-CB36	28.16	0.15	0.15	0.004
IF-PR-CB40	16.41	1.06	1.17	0.015
IF-PR-CBMH104	37.13	0.15	0.15	0.005
IF-PR-CBMH105	60.57	0.27	0.27	0.014
IF-PR-CBMH106	40.49	0.52	0.52	0.018
IF-PR-CBMH107	41.42	0.21	0.21	0.007
IF-PR-CBMH108	42.97	0.58	0.58	0.021
IF-PR-CBMH109	66.69	1.55	1.55	0.089
IF-PR-CBMH110	49.75	1.24	1.24	0.053

4837 Albion Road - Hard Rock Ottawa (116111)  
 PCSWMM Model Output - Pr. Conditions (100-year, 3-hour Chicago Storm)

IF-PR-CBMH111	34.96	0.94	0.94	0.028
IF-PR-CBMH112	56.68	2.17	2.18	0.106
IF-PR-CBMH114	77.44	2.18	2.18	0.145
IF-PR-CBMH115	56.55	1.24	1.24	0.060
IF-PR-CBMH118	28.24	2.02	2.28	0.049
Major-01	0.00	0.00	0.00	0.000
SWM_Pond	71.74	134.36	1139.63	8.188
-----				
System	26.12	190.13	1215.95	9.082

\*\*\*\*\*  
 Link Flow Summary  
 \*\*\*\*\*

-----						
Link	Type	Maximum  Flow  LPS	Time of Max Occurrence days hr:min	Maximum  Veloc  m/sec	Max/ Full Flow	Max/ Full Depth
-----						
108_(CB)	CONDUIT	36.38	0 01:04	0.74	0.85	1.00
115_(CB)	CONDUIT	72.82	0 01:06	1.47	0.75	1.00
121_(CB)	CONDUIT	41.66	0 01:10	0.95	0.61	1.00
138_(CB)_1	CONDUIT	21.06	0 01:05	0.30	0.39	1.00
138_(CB)_2	CONDUIT	42.92	0 01:04	0.61	0.79	1.00
14_(STM)	CONDUIT	112.59	0 01:12	1.63	2.62	1.00
142_(STM)	CONDUIT	63.09	0 01:04	0.89	1.09	1.00
145_(CB)	CONDUIT	52.62	0 01:03	1.07	1.27	1.00
150_(1)_(STM)	CONDUIT	53.84	0 01:05	0.93	0.79	1.00
156_(STM)	CONDUIT	18.96	0 01:03	0.47	0.44	1.00
163_(STM)	CONDUIT	41.01	0 01:06	0.58	0.58	1.00
165_(CB)	CONDUIT	128.74	0 01:05	1.82	1.86	1.00
17_(1)_(STM)	CONDUIT	96.69	0 01:09	1.40	1.41	1.00
20_(STM)	CONDUIT	39.03	0 01:29	1.34	0.46	0.93
226_(CB)	CONDUIT	8.93	0 01:10	0.66	0.21	1.00
230_(CB)	CONDUIT	38.94	0 01:05	0.79	0.92	1.00
246_(CB)	CONDUIT	57.93	0 01:03	1.18	1.39	1.00
250_(CB)	CONDUIT	20.04	0 01:04	0.41	0.49	1.00
251_(CB)	CONDUIT	21.28	0 01:04	0.50	0.50	1.00
268_(STM)	CONDUIT	44.79	0 01:07	0.97	0.65	1.00
271_(CB)	CONDUIT	15.60	0 01:04	0.50	0.66	1.00

28_(1)_(STM)	CONDUIT	35.90	0 02:11	1.25	0.37	0.48
28_(STM)	CONDUIT	59.06	0 01:34	1.20	0.61	0.66
30_(STM)	CONDUIT	21.24	0 02:26	1.00	0.25	0.36
32_(STM)	CONDUIT	10.47	0 02:11	0.82	0.11	0.26
34_(1)_(STM)	CONDUIT	50.55	0 01:02	1.03	1.22	1.00
34_(STM)	CONDUIT	99.82	0 01:03	2.03	1.83	1.00
36_(1)_(STM)	CONDUIT	106.40	0 01:02	1.51	1.57	1.00
36_(STM)	CONDUIT	168.14	0 01:04	2.38	2.49	1.00
42_(1)_(STM)	CONDUIT	71.96	0 01:02	1.02	1.04	1.00
42_(2)_(STM)	CONDUIT	108.50	0 01:03	1.53	1.60	1.00
49_(STM)	CONDUIT	71.88	0 01:02	1.02	1.07	1.00
5_(STM)_1	CONDUIT	30.13	0 01:43	0.53	0.20	1.00
5_(STM)_2	CONDUIT	79.39	0 01:44	0.92	0.52	1.00
54_(STM)	CONDUIT	169.67	0 01:04	2.40	2.51	1.00
57_(STM)	CONDUIT	17.04	0 01:13	0.68	0.25	1.00
59_(STM)	CONDUIT	94.57	0 01:02	1.93	2.27	1.00
61_(STM)	CONDUIT	41.57	0 01:01	0.85	0.98	1.00
64_(CB)	CONDUIT	57.46	0 01:07	1.18	0.96	1.00
7_(STM)	CONDUIT	120.72	0 01:44	0.97	0.52	1.00
86_(CB)	CONDUIT	48.55	0 01:03	0.99	1.17	1.00
9_(1)_(STM)	CONDUIT	289.53	0 01:42	1.02	0.86	1.00
9_(STM)_2	CONDUIT	269.21	0 01:42	0.95	0.81	1.00
94_(CB)	CONDUIT	38.11	0 01:03	0.78	0.90	1.00
C1	CONDUIT	31.00	0 01:02	1.11	0.35	1.00
C10	CONDUIT	0.00	0 00:00	0.00	0.00	0.12
C100	CONDUIT	0.00	0 00:00	0.00	0.00	0.10
C101	CONDUIT	0.00	0 00:00	0.00	0.00	0.09
C102	CONDUIT	0.00	0 00:00	0.00	0.00	0.11
C103	CONDUIT	0.00	0 00:00	0.00	0.00	0.11
C104	CONDUIT	0.00	0 00:00	0.00	0.00	0.08
C105	CONDUIT	0.00	0 00:00	0.00	0.00	0.09
C106	CONDUIT	0.00	0 00:00	0.00	0.00	0.10
C107	CONDUIT	0.00	0 00:00	0.00	0.00	0.10
C108	CONDUIT	0.00	0 00:00	0.00	0.00	0.09
C109	CONDUIT	0.00	0 00:00	0.00	0.00	0.09
C11	CONDUIT	0.00	0 00:00	0.00	0.00	0.12
C110	CONDUIT	0.00	0 00:00	0.00	0.00	0.03
C111	CONDUIT	0.00	0 00:00	0.00	0.00	0.11
C112	CONDUIT	0.00	0 00:00	0.00	0.00	0.09
C113	CONDUIT	0.00	0 00:00	0.00	0.00	0.03
C114	CONDUIT	0.00	0 00:00	0.00	0.00	0.03

4837 Albion Road - Hard Rock Ottawa (116111)  
 PCSWMM Model Output - Pr. Conditions (100-year, 3-hour Chicago Storm)

C115	CONDUIT	0.00	0	00:00	0.00	0.00	0.09
C116	CONDUIT	0.00	0	00:00	0.00	0.00	0.09
C117	CONDUIT	0.00	0	00:00	0.00	0.00	0.06
C118	CONDUIT	0.00	0	00:00	0.00	0.00	0.06
C119	CONDUIT	0.00	0	00:00	0.00	0.00	0.05
C12	CONDUIT	0.00	0	00:00	0.00	0.00	0.12
C120	CONDUIT	0.00	0	00:00	0.00	0.00	0.09
C121	CONDUIT	0.00	0	00:00	0.00	0.00	0.07
C122	CONDUIT	0.00	0	00:00	0.00	0.00	0.07
C123	CONDUIT	0.00	0	00:00	0.00	0.00	0.05
C124	CONDUIT	0.00	0	00:00	0.00	0.00	0.05
C125	CONDUIT	0.00	0	00:00	0.00	0.00	0.05
C126	CONDUIT	0.00	0	00:00	0.00	0.00	0.09
C127	CONDUIT	0.00	0	00:00	0.00	0.00	0.04
C128	CONDUIT	17.64	0	01:09	0.13	0.00	0.05
C129	CONDUIT	17.65	0	01:09	0.67	0.00	0.05
C13	CONDUIT	0.00	0	00:00	0.00	0.00	0.11
C130	CONDUIT	0.00	0	00:00	0.00	0.00	0.06
C131	CONDUIT	0.00	0	00:00	0.00	0.00	0.13
C132	CONDUIT	0.00	0	00:00	0.00	0.00	0.05
C133	CONDUIT	0.00	0	00:00	0.00	0.00	0.06
C134	CONDUIT	12.81	0	01:10	0.86	0.00	0.06
C135	CONDUIT	0.00	0	00:00	0.00	0.00	0.00
C136	CONDUIT	0.00	0	00:00	0.00	0.00	0.00
C137	CONDUIT	0.00	0	00:00	0.00	0.00	0.00
C138	CONDUIT	0.00	0	00:00	0.00	0.00	0.05
C139	CONDUIT	0.00	0	00:00	0.00	0.00	0.00
C14	CONDUIT	0.00	0	00:00	0.00	0.00	0.11
C140	CONDUIT	0.00	0	00:00	0.00	0.00	0.12
C141	CONDUIT	0.00	0	00:00	0.00	0.00	0.11
C142	CONDUIT	6.51	0	01:29	0.02	0.00	0.13
C143	CONDUIT	6.50	0	01:29	0.03	0.00	0.09
C144	CONDUIT	0.00	0	00:00	0.00	0.00	0.07
C145	CONDUIT	0.00	0	00:00	0.00	0.00	0.07
C146	CONDUIT	0.00	0	00:00	0.00	0.00	0.00
C147	CONDUIT	0.00	0	00:00	0.00	0.00	0.13
C148	CONDUIT	0.00	0	00:00	0.00	0.00	0.08
C149	CONDUIT	0.00	0	00:00	0.00	0.00	0.13
C15	CONDUIT	0.00	0	00:00	0.00	0.00	0.11
C150	CONDUIT	15.62	0	01:03	0.09	0.00	0.06
C151	CONDUIT	0.00	0	00:00	0.00	0.00	0.04

C152	CONDUIT	0.00	0	00:00	0.00	0.00	0.11
C16	CONDUIT	0.00	0	00:00	0.00	0.00	0.09
C17	CONDUIT	0.00	0	00:00	0.00	0.00	0.11
C18	CONDUIT	0.00	0	00:00	0.00	0.00	0.12
C19	CONDUIT	0.00	0	00:00	0.00	0.00	0.10
C2	CONDUIT	0.00	0	00:00	0.00	0.00	0.10
C20	CONDUIT	0.00	0	00:00	0.00	0.00	0.10
C21	CONDUIT	0.00	0	00:00	0.00	0.00	0.10
C22	CONDUIT	0.00	0	00:00	0.00	0.00	0.10
C23	CONDUIT	17.10	0	01:20	0.82	0.00	0.08
C24	CONDUIT	10.80	0	01:30	0.67	0.00	0.08
C25	CONDUIT	8.25	0	01:30	0.06	0.00	0.08
C26	CONDUIT	0.00	0	00:00	0.00	0.00	0.12
C27	CONDUIT	0.00	0	00:00	0.00	0.00	0.09
C28	CONDUIT	0.00	0	00:00	0.00	0.00	0.12
C29	CONDUIT	0.00	0	00:00	0.00	0.00	0.09
C3	CONDUIT	0.00	0	00:00	0.00	0.00	0.10
C30	CONDUIT	0.00	0	00:00	0.00	0.00	0.00
C31	CONDUIT	0.00	0	00:00	0.00	0.00	0.07
C32	CONDUIT	0.00	0	00:00	0.00	0.00	0.12
C33	CONDUIT	0.00	0	00:00	0.00	0.00	0.01
C34	CONDUIT	0.00	0	00:00	0.00	0.00	0.11
C35	CONDUIT	0.00	0	00:00	0.00	0.00	0.11
C36	CONDUIT	0.00	0	00:00	0.00	0.00	0.11
C37	CONDUIT	0.00	0	00:00	0.00	0.00	0.11
C38	CONDUIT	0.00	0	00:00	0.00	0.00	0.11
C39	CONDUIT	0.00	0	00:00	0.00	0.00	0.07
C4	CONDUIT	0.00	0	00:00	0.00	0.00	0.10
C40	CONDUIT	0.00	0	00:00	0.00	0.00	0.08
C41	CONDUIT	0.00	0	00:00	0.00	0.00	0.07
C42	CONDUIT	0.00	0	00:00	0.00	0.00	0.08
C43	CONDUIT	0.00	0	00:00	0.00	0.00	0.08
C44	CONDUIT	0.00	0	00:00	0.00	0.00	0.08
C45	CONDUIT	0.00	0	00:00	0.00	0.00	0.08
C46	CONDUIT	0.00	0	00:00	0.00	0.00	0.08
C47	CONDUIT	0.00	0	00:00	0.00	0.00	0.08
C48	CONDUIT	0.00	0	00:00	0.00	0.00	0.08
C49	CONDUIT	0.00	0	00:00	0.00	0.00	0.06
C5	CONDUIT	0.00	0	00:00	0.00	0.00	0.09
C50	CONDUIT	0.00	0	00:00	0.00	0.00	0.08
C51	CONDUIT	0.00	0	00:00	0.00	0.00	0.08



4837 Albion Road - Hard Rock Ottawa (116111)  
 PCSWMM Model Output - Pr. Conditions (100-year, 3-hour Chicago Storm)

C52	CONDUIT	0.00	0 00:00	0.00	0.00	0.09
C53	CONDUIT	0.00	0 00:00	0.00	0.00	0.09
C53_1	CONDUIT	0.00	0 00:00	0.00	0.00	0.09
C53_2	CONDUIT	0.00	0 00:00	0.00	0.00	0.09
C54	CONDUIT	9.47	0 01:11	0.06	0.00	0.06
C54_1	CONDUIT	0.00	0 00:00	0.00	0.00	0.09
C54_2	CONDUIT	0.00	0 00:00	0.00	0.00	0.09
C55	CONDUIT	0.00	0 00:00	0.00	0.00	0.09
C56	CONDUIT	0.00	0 00:00	0.00	0.00	0.09
C57	CONDUIT	0.00	0 00:00	0.00	0.00	0.09
C58	CONDUIT	0.00	0 00:00	0.00	0.00	0.09
C59	CONDUIT	0.00	0 00:00	0.00	0.00	0.09
C6	CONDUIT	0.00	0 00:00	0.00	0.00	0.10
C60	CONDUIT	0.00	0 00:00	0.00	0.00	0.09
C61	CONDUIT	0.00	0 00:00	0.00	0.00	0.09
C62	CONDUIT	0.00	0 00:00	0.00	0.00	0.09
C63	CONDUIT	0.00	0 00:00	0.00	0.00	0.09
C65	CONDUIT	8.54	0 01:11	0.03	0.00	0.13
C66	CONDUIT	0.00	0 00:00	0.00	0.00	0.13
C67	CONDUIT	0.00	0 00:00	0.00	0.00	0.13
C68	CONDUIT	2.57	0 01:31	0.01	0.00	0.10
C69	CONDUIT	2.57	0 01:31	0.06	0.00	0.07
C7	CONDUIT	0.00	0 00:00	0.00	0.00	0.12
C70	CONDUIT	0.00	0 00:00	0.00	0.00	0.04
C71	CONDUIT	8.43	0 01:40	0.04	0.00	0.08
C72	CONDUIT	0.00	0 00:00	0.00	0.00	0.11
C73	CONDUIT	6.96	0 01:38	0.03	0.00	0.08
C74	CONDUIT	2.16	0 01:37	0.01	0.00	0.08
C75	CONDUIT	0.00	0 00:00	0.00	0.00	0.07
C76	CONDUIT	0.00	0 00:00	0.00	0.00	0.08
C77	CONDUIT	8.43	0 01:40	0.80	0.00	0.00
C78	CONDUIT	42.25	0 01:50	0.56	0.00	0.03
C79	CONDUIT	6.96	0 01:38	0.68	0.00	0.00
C8	CONDUIT	0.00	0 00:00	0.00	0.00	0.10
C80	CONDUIT	0.00	0 00:00	0.00	0.00	0.11
C81	CONDUIT	2.16	0 01:37	0.00	0.00	0.00
C82	CONDUIT	16.68	0 01:38	0.01	0.00	0.50
C83	CONDUIT	0.00	0 00:00	0.00	0.00	0.34
C84	CONDUIT	0.00	0 00:00	0.00	0.00	0.06
C84_2	CONDUIT	0.00	0 00:00	0.00	0.00	0.08
C85	CONDUIT	0.00	0 00:00	0.00	0.00	0.00

C86	CONDUIT	0.00	0 00:00	0.00	0.00	0.00
C87	CONDUIT	0.00	0 00:00	0.00	0.00	0.00
C88	CONDUIT	19.03	0 01:14	0.10	0.00	0.06
C89	CONDUIT	0.00	0 00:00	0.00	0.00	0.09
C9	CONDUIT	0.00	0 00:00	0.00	0.00	0.11
C90	CONDUIT	0.00	0 00:00	0.00	0.00	0.09
C91	CONDUIT	0.00	0 00:00	0.00	0.00	0.07
C92	CONDUIT	12.65	0 01:20	0.05	0.00	0.08
C93	CONDUIT	11.18	0 01:20	0.04	0.00	0.09
C94	CONDUIT	31.18	0 01:19	0.84	0.00	0.16
C95	CONDUIT	38.19	0 01:18	0.28	0.00	0.10
C96	CONDUIT	0.00	0 00:00	0.00	0.00	0.05
C97	CONDUIT	0.00	0 00:00	0.00	0.00	0.06
C98	CONDUIT	0.00	0 00:00	0.00	0.00	0.06
C99	CONDUIT	0.00	0 00:00	0.00	0.00	0.08
C-CB22	CONDUIT	10.80	0 01:30	0.03	0.00	0.11
C-CB23	CONDUIT	17.11	0 01:20	0.05	0.00	0.11
C-CB24	CONDUIT	0.00	0 00:00	0.00	0.00	0.11
C-CB25	CONDUIT	0.00	0 00:00	0.00	0.00	0.12
C-CB87	CONDUIT	0.00	0 00:00	0.00	0.00	0.08
C-CBMH112	CONDUIT	8.25	0 01:30	0.03	0.00	0.10
C-CBMH114	CONDUIT	0.00	0 00:00	0.00	0.00	0.11
EXMH101-OUT	CONDUIT	1139.63	0 01:20	3.88	0.72	0.63
EXMH115-101	CONDUIT	100.32	0 02:22	1.43	1.47	1.00
EXMH116-115	CONDUIT	103.90	0 01:09	1.47	1.53	1.00
PRMH116-EX-MH116	CONDUIT	138.87	0 01:09	3.11	0.96	1.00
X-CB-129_(X-CB)	CONDUIT	65.44	0 01:03	2.08	2.39	1.00
X-CB-89_(X-CB)	CONDUIT	50.10	0 01:03	1.59	0.78	1.00
X-CB-91_(X-CB)	CONDUIT	53.94	0 01:03	1.72	0.73	1.00
X-CB-94_(X-CB)	CONDUIT	52.38	0 01:02	1.67	1.37	1.00
X-CB-97_(X-CB)	CONDUIT	69.97	0 01:02	0.99	0.86	1.00
X-CB-98_(X-CB)	CONDUIT	76.57	0 01:04	1.08	2.21	1.00
X-STM-13_(1)_(X-STM)	CONDUIT	967.51	0 01:23	3.25	0.74	0.64
X-STM-13_(X-STM)	CONDUIT	967.51	0 01:23	3.70	0.58	0.57
X-STM-17_(X-STM)	CONDUIT	910.16	0 01:23	3.36	0.65	0.59
X-STM-19_(X-STM)	CONDUIT	59.06	0 01:35	1.30	0.65	0.61
X-STM-21_(X-STM)	CONDUIT	840.38	0 01:22	3.00	1.19	0.97
X-STM-23_(X-STM)	CONDUIT	124.53	0 01:31	1.20	1.05	0.89
X-STM-25_(X-STM)_1	CONDUIT	109.26	0 02:17	1.30	0.30	1.00
X-STM-25_(X-STM)_2	CONDUIT	131.85	0 01:03	0.83	0.36	1.00
X-STM-27_(X-STM)_1	CONDUIT	96.43	0 01:03	1.36	1.82	1.00

4837 Albion Road - Hard Rock Ottawa (116111)  
 PCSWMM Model Output - Pr. Conditions (100-year, 3-hour Chicago Storm)

X-STM-27_(X-STM)_2	CONDUIT	134.36	0	01:03	1.90	3.39	1.00
X-STM-29_(X-STM)	CONDUIT	95.16	0	01:02	1.35	3.79	1.00
X-STM-31_(X-STM)	CONDUIT	99.45	0	01:02	1.41	1.51	1.00
X-STM-33_(X-STM)	CONDUIT	586.90	0	01:35	2.08	1.65	1.00
X-STM-51_(X-STM)	CONDUIT	94.80	0	01:03	1.34	3.26	1.00
X-STM-53_(X-STM)	CONDUIT	76.03	0	01:46	1.08	1.84	1.00
X-STM-55_(X-STM)	CONDUIT	83.10	0	01:02	1.69	1.79	1.00
X-STM-59_(X-STM)	CONDUIT	52.51	0	01:03	1.67	1.59	1.00
X-STM-63_(X-STM)	CONDUIT	20.90	0	01:51	0.71	0.85	1.00
X-STM-71_(X-STM)	CONDUIT	11.57	0	01:12	0.94	0.11	0.23
X-STM-75_(X-STM)	CONDUIT	188.54	0	01:12	1.71	1.02	1.00
X-STM-77_(X-STM)	CONDUIT	178.94	0	01:23	1.62	1.56	1.00
102_(5)_(CB)	ORIFICE	7.51	0	01:44			1.00
114_(CB)	ORIFICE	14.40	0	01:37			1.00
124_(CB)	ORIFICE	9.12	0	01:13			1.00
131_(CB)	ORIFICE	54.22	0	01:50			1.00
147_(CB)	ORIFICE	7.76	0	01:51			1.00
267_(STM)	ORIFICE	7.60	0	01:06			1.00
42_(STM)	ORIFICE	14.70	0	01:31			1.00
46_(STM)	ORIFICE	10.77	0	02:50			1.00
66_(CB)	ORIFICE	8.47	0	01:50			1.00
69_(CB)	ORIFICE	14.08	0	01:38			1.00
78_(CB)	ORIFICE	8.01	0	01:08			1.00
81_(CB)	ORIFICE	7.88	0	01:09			1.00
88_(CB)	ORIFICE	7.52	0	01:50			1.00
96_(CB)	ORIFICE	7.30	0	01:43			1.00
OR1	ORIFICE	8.17	0	01:49			1.00
OR10	ORIFICE	9.94	0	01:41			1.00
OR11	ORIFICE	116.78	0	01:03			1.00
OR12	ORIFICE	6.05	0	01:11			1.00
OR13	ORIFICE	4.36	0	01:48			1.00
OR14	ORIFICE	19.43	0	01:03			1.00
OR15	ORIFICE	35.43	0	01:11			1.00
OR2	ORIFICE	10.47	0	02:10			1.00
OR3	ORIFICE	31.55	0	01:10			1.00
OR4	ORIFICE	9.44	0	02:30			1.00
OR5	ORIFICE	8.74	0	02:05			1.00
OR6	ORIFICE	97.00	0	01:10			1.00
OR7	ORIFICE	122.26	0	01:34			1.00
OR8	ORIFICE	11.04	0	01:41			1.00
OR9	ORIFICE	7.88	0	01:48			1.00

X-CB-135_(X-CB)	ORIFICE	47.28	0	01:09			1.00
X-CB-83_(X-CB)	ORIFICE	96.31	0	01:11			1.00
X-CB-86_(X-CB)	ORIFICE	35.50	0	01:11			1.00
X-STM-15_(X-STM)	ORIFICE	57.55	0	01:42			1.00
X-STM-73_(X-STM)	ORIFICE	11.58	0	01:11			1.00
EX-BLDG01-OUT	DUMMY	178.60	0	01:11			
INFIL-EX-CB116	DUMMY	0.14	0	00:25			
INFIL-EX-CB117	DUMMY	0.14	0	00:25			
INFIL-EX-CB128	DUMMY	0.14	0	00:26			
INFIL-EX-CB137	DUMMY	0.21	0	00:25			
INFIL-EX-CB14	DUMMY	0.14	0	00:24			
INFIL-EX-CB28	DUMMY	0.14	0	00:24			
INFIL-EX-CB30	DUMMY	0.14	0	00:25			
INFIL-EX-CB50	DUMMY	0.14	0	00:24			
INFIL-EX-CB52	DUMMY	0.14	0	00:25			
INFIL-EX-CB54	DUMMY	0.14	0	00:25			
INFIL-EX-CB58	DUMMY	0.14	0	00:25			
INFIL-EX-CB64	DUMMY	0.14	0	00:25			
INFIL-EX-CB82	DUMMY	0.21	0	00:25			
INFIL-EX-CB84	DUMMY	0.21	0	00:25			
INFIL-EX-CB87	DUMMY	0.14	0	00:25			
INFIL-EX-CB90	DUMMY	0.14	0	00:25			
INFIL-EX-CB92	DUMMY	0.14	0	00:25			
INFIL-EX-CB95	DUMMY	0.14	0	00:26			
INFIL-EX-CB96	DUMMY	0.14	0	00:24			
INFIL-PR-CB04	DUMMY	0.39	0	00:25			
INFIL-PR-CB13	DUMMY	0.15	0	00:25			
INFIL-PR-CB14	DUMMY	0.15	0	00:26			
INFIL-PR-CB18	DUMMY	0.15	0	00:25			
INFIL-PR-CB29	DUMMY	1.17	0	00:28			
INFIL-PR-CB32	DUMMY	1.61	0	00:28			
INFIL-PR-CB36	DUMMY	0.15	0	00:25			
INFIL-PR-CB40	DUMMY	1.17	0	00:27			
INFIL-PR-CBMH104	DUMMY	0.15	0	00:25			
INFIL-PR-CBMH105	DUMMY	0.27	0	00:25			
INFIL-PR-CBMH106	DUMMY	0.52	0	00:26			
INFIL-PR-CBMH107	DUMMY	0.21	0	00:24			
INFIL-PR-CBMH108	DUMMY	0.58	0	00:26			
INFIL-PR-CBMH109	DUMMY	1.55	0	00:26			
INFIL-PR-CBMH110	DUMMY	1.24	0	00:26			
INFIL-PR-CBMH111	DUMMY	0.94	0	00:27			





4837 Albion Road - Hard Rock Ottawa (116111)  
 PCSWMM Model Output - Pr. Conditions (100-year, 3-hour Chicago Storm)

C53_2	1.00	0.85	0.15	0.00	0.00	0.00	0.00	0.00	0.00	0.00
C54	1.00	0.97	0.01	0.00	0.02	0.00	0.00	0.00	0.02	0.00
C54_1	1.00	0.85	0.15	0.00	0.00	0.00	0.00	0.00	0.00	0.00
C54_2	1.00	0.85	0.15	0.00	0.00	0.00	0.00	0.00	0.00	0.00
C55	1.00	0.85	0.15	0.00	0.00	0.00	0.00	0.00	0.00	0.00
C56	1.00	0.85	0.15	0.00	0.00	0.00	0.00	0.00	0.00	0.00
C57	1.00	0.85	0.15	0.00	0.00	0.00	0.00	0.00	0.00	0.00
C58	1.00	0.85	0.15	0.00	0.00	0.00	0.00	0.00	0.00	0.00
C59	1.00	0.85	0.15	0.00	0.00	0.00	0.00	0.00	0.00	0.00
C6	1.00	0.77	0.23	0.00	0.00	0.00	0.00	0.00	0.00	0.00
C60	1.00	0.85	0.15	0.00	0.00	0.00	0.00	0.00	0.00	0.00
C61	1.00	0.85	0.15	0.00	0.00	0.00	0.00	0.00	0.00	0.00
C62	1.00	0.85	0.15	0.00	0.00	0.00	0.00	0.00	0.00	0.00
C63	1.00	0.85	0.15	0.00	0.00	0.00	0.00	0.00	0.00	0.00
C65	1.00	0.85	0.12	0.00	0.02	0.00	0.00	0.00	0.94	0.00
C66	1.00	0.85	0.15	0.00	0.00	0.00	0.00	0.00	0.00	0.00
C67	1.00	0.85	0.15	0.00	0.00	0.00	0.00	0.00	0.00	0.00
C68	1.00	0.82	0.17	0.00	0.01	0.00	0.00	0.00	0.93	0.00
C69	1.00	0.97	0.02	0.00	0.01	0.00	0.00	0.01	0.01	0.00
C7	1.00	0.65	0.35	0.00	0.00	0.00	0.00	0.00	0.00	0.00
C70	1.00	0.98	0.02	0.00	0.00	0.00	0.00	0.00	0.00	0.00
C71	1.00	0.95	0.03	0.00	0.02	0.00	0.00	0.00	0.92	0.00
C72	1.00	0.92	0.08	0.00	0.00	0.00	0.00	0.00	0.00	0.00
C73	1.00	0.95	0.04	0.00	0.02	0.00	0.00	0.00	0.92	0.00
C74	1.00	0.95	0.05	0.00	0.01	0.00	0.00	0.00	0.93	0.00
C75	1.00	0.98	0.02	0.00	0.00	0.00	0.00	0.00	0.00	0.00
C76	1.00	0.98	0.02	0.00	0.00	0.00	0.00	0.00	0.00	0.00
C77	1.00	0.98	0.00	0.00	0.00	0.02	0.00	0.00	0.92	0.00
C78	1.00	0.95	0.00	0.00	0.01	0.05	0.00	0.00	0.04	0.00
C79	1.00	0.98	0.01	0.00	0.00	0.01	0.00	0.00	0.93	0.00
C8	1.00	0.77	0.23	0.00	0.00	0.00	0.00	0.00	0.00	0.00
C80	1.00	0.92	0.08	0.00	0.00	0.00	0.00	0.00	0.00	0.00
C81	1.00	0.98	0.02	0.00	0.00	0.00	0.00	0.00	0.93	0.00
C82	1.00	0.86	0.12	0.00	0.02	0.00	0.00	0.00	0.94	0.00
C83	1.00	0.86	0.14	0.00	0.00	0.00	0.00	0.00	0.00	0.00
C84	1.00	0.98	0.02	0.00	0.00	0.00	0.00	0.00	0.00	0.00
C84_2	1.00	0.98	0.02	0.00	0.00	0.00	0.00	0.00	0.00	0.00
C85	1.00	1.00	0.00	0.00	0.00	0.00	0.00	0.00	0.00	0.00
C86	1.00	1.00	0.00	0.00	0.00	0.00	0.00	0.00	0.00	0.00
C87	1.00	1.00	0.00	0.00	0.00	0.00	0.00	0.00	0.00	0.00
C88	1.00	0.97	0.02	0.00	0.01	0.00	0.00	0.00	0.93	0.00

C89	1.00	0.94	0.06	0.00	0.00	0.00	0.00	0.00	0.00	0.00
C9	1.00	0.65	0.35	0.00	0.00	0.00	0.00	0.00	0.00	0.00
C90	1.00	0.94	0.06	0.00	0.00	0.00	0.00	0.00	0.00	0.00
C91	1.00	0.97	0.03	0.00	0.00	0.00	0.00	0.00	0.00	0.00
C92	1.00	0.95	0.04	0.00	0.01	0.00	0.00	0.00	0.94	0.00
C93	1.00	0.94	0.05	0.00	0.01	0.00	0.00	0.00	0.94	0.00
C94	1.00	0.85	0.09	0.00	0.06	0.00	0.00	0.00	0.91	0.00
C95	1.00	0.94	0.00	0.00	0.05	0.00	0.00	0.01	0.01	0.00
C96	1.00	0.97	0.03	0.00	0.00	0.00	0.00	0.00	0.00	0.00
C97	1.00	0.96	0.04	0.00	0.00	0.00	0.00	0.00	0.00	0.00
C98	1.00	0.96	0.04	0.00	0.00	0.00	0.00	0.00	0.00	0.00
C99	1.00	0.95	0.05	0.00	0.00	0.00	0.00	0.00	0.00	0.00
C-CB22	1.00	0.81	0.14	0.00	0.05	0.00	0.00	0.00	0.90	0.00
C-CB23	1.00	0.81	0.13	0.00	0.06	0.00	0.00	0.00	0.89	0.00
C-CB24	1.00	0.65	0.35	0.00	0.00	0.00	0.00	0.00	0.00	0.00
C-CB25	1.00	0.65	0.35	0.00	0.00	0.00	0.00	0.00	0.00	0.00
C-CB87	1.00	0.95	0.05	0.00	0.00	0.00	0.00	0.00	0.00	0.00
C-CBMH112	1.00	0.82	0.15	0.00	0.03	0.00	0.00	0.00	0.91	0.00
C-CBMH114	1.00	0.65	0.35	0.00	0.00	0.00	0.00	0.00	0.00	0.00
EXMH101-OUT	1.00	0.01	0.00	0.00	0.29	0.70	0.00	0.00	0.71	0.00
EXMH115-101	1.00	0.01	0.00	0.00	0.63	0.00	0.00	0.36	0.53	0.00
EXMH116-115	1.00	0.01	0.00	0.00	0.98	0.01	0.00	0.00	0.85	0.00
PRMH116-EX-MH116	1.00	0.01	0.00	0.00	0.03	0.05	0.00	0.91	0.03	0.00
X-CB-129_(X-CB)	1.00	0.84	0.00	0.00	0.09	0.00	0.00	0.07	0.00	0.00
X-CB-89_(X-CB)	1.00	0.83	0.00	0.00	0.10	0.00	0.00	0.07	0.01	0.00
X-CB-91_(X-CB)	1.00	0.84	0.00	0.00	0.10	0.00	0.00	0.06	0.01	0.00
X-CB-94_(X-CB)	1.00	0.02	0.80	0.00	0.18	0.00	0.00	0.00	0.89	0.00
X-CB-97_(X-CB)	1.00	0.83	0.00	0.00	0.12	0.00	0.00	0.05	0.02	0.00
X-CB-98_(X-CB)	1.00	0.02	0.82	0.00	0.16	0.00	0.00	0.00	0.85	0.00
X-STM-13_(1)_(X-STM)	1.00	0.01	0.00	0.00	0.00	0.00	0.00	0.99	0.00	0.00
X-STM-13_(X-STM)	1.00	0.01	0.00	0.00	0.00	0.11	0.00	0.88	0.10	0.00
X-STM-17_(X-STM)	1.00	0.01	0.00	0.00	0.00	0.00	0.00	0.99	0.00	0.00
X-STM-19_(X-STM)	1.00	0.03	0.00	0.00	0.00	0.00	0.00	0.97	0.00	0.00
X-STM-21_(X-STM)	1.00	0.01	0.00	0.00	0.00	0.00	0.00	0.99	0.00	0.00
X-STM-23_(X-STM)	1.00	0.02	0.00	0.00	0.02	0.00	0.00	0.97	0.00	0.00
X-STM-25_(X-STM)_1	1.00	0.02	0.00	0.00	0.95	0.04	0.00	0.00	0.89	0.00
X-STM-25_(X-STM)_2	1.00	0.02	0.00	0.00	0.12	0.01	0.00	0.85	0.03	0.00
X-STM-27_(X-STM)_1	1.00	0.02	0.78	0.00	0.21	0.00	0.00	0.00	0.89	0.00
X-STM-27_(X-STM)_2	1.00	0.02	0.00	0.00	0.09	0.00	0.00	0.89	0.00	0.00
X-STM-29_(X-STM)	1.00	0.83	0.00	0.00	0.09	0.00	0.00	0.07	0.00	0.00
X-STM-31_(X-STM)	1.00	0.82	0.00	0.00	0.10	0.00	0.00	0.08	0.00	0.00

4837 Albion Road - Hard Rock Ottawa (116111)  
 PCSWMM Model Output - Pr. Conditions (100-year, 3-hour Chicago Storm)

X-STM-33_(X-STM)	1.00	0.01	0.00	0.00	0.03	0.00	0.00	0.96	0.00	0.00
X-STM-51_(X-STM)	1.00	0.82	0.00	0.00	0.05	0.00	0.00	0.13	0.00	0.00
X-STM-53_(X-STM)	1.00	0.79	0.03	0.00	0.17	0.00	0.00	0.00	0.92	0.00
X-STM-55_(X-STM)	1.00	0.82	0.04	0.00	0.14	0.00	0.00	0.00	0.93	0.00
X-STM-59_(X-STM)	1.00	0.83	0.00	0.00	0.06	0.00	0.00	0.11	0.00	0.00
X-STM-63_(X-STM)	1.00	0.02	0.00	0.00	0.04	0.00	0.00	0.94	0.00	0.00
X-STM-71_(X-STM)	1.00	0.02	0.00	0.00	0.00	0.00	0.00	0.98	0.00	0.00
X-STM-75_(X-STM)	1.00	0.01	0.00	0.00	0.99	0.01	0.00	0.00	0.95	0.00
X-STM-77_(X-STM)	1.00	0.01	0.00	0.00	0.90	0.09	0.00	0.00	0.00	0.00

\*\*\*\*\*  
 Conduit Surcharge Summary  
 \*\*\*\*\*

Conduit	Hours Full			Hours	Hours
	Both Ends	Upstream	Dnstream	Above Full Normal Flow	Capacity Limited
108_(CB)	4.07	4.07	4.12	0.01	0.01
115_(CB)	2.08	2.08	3.17	0.01	0.01
121_(CB)	1.99	1.99	2.08	0.01	0.01
138_(CB)_1	4.02	4.02	4.06	0.01	0.01
138_(CB)_2	4.06	4.06	4.12	0.01	0.01
14_(STM)	0.43	1.00	0.43	1.24	0.43
142_(STM)	4.02	4.02	4.06	0.01	0.01
145_(CB)	4.82	4.82	5.88	0.04	0.04
150_(1)_(STM)	0.65	0.65	1.12	0.01	0.01
156_(STM)	4.03	4.03	4.09	0.01	0.01
163_(STM)	1.36	1.36	1.41	0.01	0.01
165_(CB)	1.40	1.43	1.89	0.08	0.05
17_(1)_(STM)	0.59	1.28	0.59	1.31	0.59
20_(STM)	0.01	0.01	0.66	0.01	0.01
226_(CB)	0.30	0.30	0.39	0.01	0.01
230_(CB)	3.50	3.50	3.97	0.01	0.01
246_(CB)	4.23	4.23	4.86	0.03	0.03
250_(CB)	4.06	4.06	4.18	0.01	0.01
251_(CB)	4.03	4.03	4.18	0.01	0.01
268_(STM)	0.40	0.40	0.64	0.01	0.01
271_(CB)	3.94	3.94	4.05	0.01	0.01

34_(1)_(STM)	5.67	5.67	5.74	0.02	0.02
34_(STM)	5.73	5.75	7.75	0.08	0.07
36_(1)_(STM)	8.78	8.78	9.11	0.09	0.09
36_(STM)	9.25	9.27	11.82	0.11	0.08
42_(1)_(STM)	4.72	4.72	4.80	0.01	0.01
42_(2)_(STM)	4.80	4.80	4.89	0.12	0.11
49_(STM)	8.67	8.67	8.76	0.01	0.01
5_(STM)_1	0.25	0.25	0.44	0.01	0.01
5_(STM)_2	0.45	0.45	0.56	0.01	0.01
54_(STM)	5.19	5.22	7.24	0.13	0.08
57_(STM)	0.35	0.35	0.51	0.01	0.01
59_(STM)	8.07	8.07	10.11	0.09	0.09
61_(STM)	7.37	7.37	7.95	0.01	0.01
64_(CB)	3.64	3.64	6.16	0.01	0.02
7_(STM)	0.56	0.56	0.72	0.01	0.01
86_(CB)	4.41	4.41	5.38	0.03	0.04
9_(1)_(STM)	0.82	0.82	0.84	0.01	0.30
9_(STM)_2	0.74	0.74	0.81	0.01	0.01
94_(CB)	3.08	3.08	3.54	0.01	0.01
C1	1.47	1.47	1.89	0.01	0.01
C82	0.01	0.01	22.45	0.01	0.01
EXMH115-101	1.16	1.95	1.19	1.94	1.15
EXMH116-115	1.92	1.94	1.95	1.96	1.91
PRMH116-EX-MH116	0.67	0.67	1.80	0.01	0.01
X-CB-129_(X-CB)	1.95	1.95	1.99	0.01	0.01
X-CB-89_(X-CB)	1.92	1.92	2.29	0.01	0.01
X-CB-91_(X-CB)	1.91	1.91	2.29	0.01	0.01
X-CB-94_(X-CB)	1.99	1.99	2.26	0.02	0.03
X-CB-97_(X-CB)	1.92	1.92	2.09	0.01	0.01
X-CB-98_(X-CB)	2.14	2.15	2.15	0.33	1.07
X-STM-21_(X-STM)	0.01	0.60	0.01	0.64	0.01
X-STM-23_(X-STM)	0.01	0.01	0.01	1.12	0.01
X-STM-25_(X-STM)_1	1.98	1.98	2.25	0.01	0.01
X-STM-25_(X-STM)_2	2.25	2.25	2.40	0.01	0.01
X-STM-27_(X-STM)_1	2.03	2.03	2.15	0.24	0.24
X-STM-27_(X-STM)_2	2.11	2.15	2.11	2.28	2.11
X-STM-29_(X-STM)	1.96	1.96	1.97	0.48	0.87
X-STM-31_(X-STM)	1.89	1.89	1.98	0.01	0.01
X-STM-33_(X-STM)	0.55	0.86	0.55	0.93	0.55
X-STM-51_(X-STM)	1.03	1.12	1.03	1.26	1.03
X-STM-53_(X-STM)	1.01	1.01	1.12	0.27	0.28

4837 Albion Road - Hard Rock Ottawa (116111)  
PCSWMM Model Output - Pr. Conditions (100-year, 3-hour Chicago Storm)

X-STM-55_(X-STM)	0.99	0.99	1.06	0.02	0.02
X-STM-59_(X-STM)	1.04	1.04	1.21	0.22	0.51
X-STM-63_(X-STM)	0.88	0.88	0.88	0.01	0.01
X-STM-75_(X-STM)	0.84	0.84	1.25	0.16	0.47
X-STM-77_(X-STM)	0.83	0.83	0.84	0.61	0.67

Analysis begun on: Mon Nov 7 14:09:36 2022  
Analysis ended on: Mon Nov 7 14:09:58 2022  
Total elapsed time: 00:00:22

## **Appendix E**

### Development Servicing Checklist



**Hard Rock Hotel Casino  
4837 Albion Road, Ottawa  
DEVELOPMENT SERVICING STUDY CHECKLIST**

4.1 General Content	Addressed (Y/N/NA)	Comments
Executive Summary (for larger reports only).	N/A	
Date and revision number of the report.	Y	
Location map and plan showing municipal address, boundary, and layout of proposed development.	Y	Refer to Report Figures
Plan showing the site and location of all existing services.	Y	Refer to Grading and Servicing Plans
Development statistics, land use, density, adherence to zoning and official plan, and reference to applicable subwatershed and watershed plans that provide context to which individual developments must adhere.	Y	Refer to Site Plan
Summary of Pre-consultation Meetings with City and other approval agencies.	Y	
Reference and confirm conformance to higher level studies and reports (Master Servicing Studies, Environmental Assessments, Community Design Plans), or in the case where it is not in conformance, the proponent must provide justification and develop a defensible design criteria.	N/A	
Statement of objectives and servicing criteria.	Y	Report Sections: 2.0 Water Servicing , 3.0 Sanitary Servicing, 4.0 Storm Servicing and Stormwater Management
Identification of existing and proposed infrastructure available in the immediate area.	Y	
Identification of Environmentally Significant Areas, watercourses and Municipal Drains potentially impacted by the proposed development (Reference can be made to the Natural Heritage Studies, if available).	N/A	
Concept level master grading plan to confirm existing and proposed grades in the development. This is required to confirm the feasibility of proposed stormwater management and drainage, soil removal and fill constraints, and potential impacts to neighboring properties. This is also required to confirm that the proposed grading will not impede existing major system flow paths.	Y	Refer to Grading Plan and Stormwater Management Plan

**Hard Rock Hotel Casino  
4837 Albion Road, Ottawa  
DEVELOPMENT SERVICING STUDY CHECKLIST**

4.1 General Content	Addressed (Y/N/NA)	Comments
Identification of potential impacts of proposed piped services on private services (such as wells and septic fields on adjacent lands) and mitigation required to address potential impacts.	N/A	
Proposed phasing of the development, if applicable.	N/A	
Reference to geotechnical studies and recommendations concerning servicing.	Y	Report Section 4.0 Site Constraints
All preliminary and formal site plan submissions should have the following information:		
Metric scale	Y	
North arrow (including construction North)	Y	
Key plan	Y	
Name and contact information of applicant and property owner	Y	
Property limits including bearings and dimensions	Y	
Existing and proposed structures and parking areas	Y	
Easements, road widening and rights-of-way	Y	
Adjacent street names	Y	

**Hard Rock Hotel Casino  
4837 Albion Road, Ottawa  
DEVELOPMENT SERVICING STUDY CHECKLIST**

4.2 Water	Addressed (Y/N/NA)	Comments
Confirm consistency with Master Servicing Study, if available.	N/A	
Availability of public infrastructure to service proposed development.	Y	Report Sections: 2.0 Water Servicing , 3.0 Sanitary Servicing,4.0 Storm Servicing and Stormwater Management
Identification of system constraints.	N/A	
Identify boundary conditions.	Y	Provided by City of Ottawa
Confirmation of adequate domestic supply and pressure.	Y	Refer to Appendix A
Confirmation of adequate fire flow protection and confirmation that fire flow is calculated as per the Fire Underwriter’s Survey. Output should show available fire flow at locations throughout the development.	Y	Refer to Appendix A
Provide a check of high pressures. If pressure is found to be high, an assessment is required to confirm the application of pressure reducing valves.	Y	Refer to Appendix A
Definition of phasing constraints. Hydraulic modeling is required to confirm servicing for all defined phases of the project including the ultimate design.	N/A	
Address reliability requirements such as appropriate location of shut-off valves.	Y	Refer to Appendix A
Check on the necessity of a pressure zone boundary modification.	N/A	
Reference to water supply analysis to show that major infrastructure is capable of delivering sufficient water for the proposed land use. This includes data that shows that the expected demands under average day, peak hour and fire flow conditions provide water within the required pressure range.	Y	Report Section 2.0 Water Servicing
Description of the proposed water distribution network, including locations of proposed connections to the existing system, provisions for necessary looping, and appurtenances (valves, pressure reducing valves, valve chambers, and fire hydrants) including special metering provisions.	Y	Report Section 2.0 Water Servicing
Description of off-site required feeder mains, booster pumping stations, and other water infrastructure that will be ultimately required to service proposed development, including financing, interim facilities, and timing of implementation.	N/A	
Confirmation that water demands are calculated based on the City of Ottawa Design Guidelines.	Y	Report Section 2.0 Water Servicing
Provision of a model schematic showing the boundary conditions locations, streets, parcels, and building locations for reference.	N/A	

**Hard Rock Hotel Casino  
4837 Albion Road, Ottawa  
DEVELOPMENT SERVICING STUDY CHECKLIST**

4.3 Wastewater	Addressed (Y/N/NA)	Comments
Summary of proposed design criteria (Note: Wet-weather flow criteria should not deviate from the City of Ottawa Sewer Design Guidelines. Monitored flow data from relatively new infrastructure cannot be used to justify capacity requirements for proposed infrastructure).	Y	Report Section 3.0 Sanitary Servicing
Confirm consistency with Master Servicing Study and/or justifications for deviations.	N/A	
Consideration of local conditions that may contribute to extraneous flows that are higher than the recommended flows in the guidelines. This includes groundwater and soil conditions, and age and condition of sewers.	N/A	
Description of existing sanitary sewer available for discharge of wastewater from proposed development.	Y	Report Section 3.0 Sanitary Servicing
Verify available capacity in downstream sanitary sewer and/or identification of upgrades necessary to service the proposed development. (Reference can be made to previously completed Master Servicing Study if applicable)	Y	Refer to Appendix B
Calculations related to dry-weather and wet-weather flow rates from the development in standard MOE sanitary sewer design table (Appendix 'C') format.	N/A	
Description of proposed sewer network including sewers, pumping stations, and forcemains.	Y	Report Section 3.0 Sanitary Servicing
Discussion of previously identified environmental constraints and impact on servicing (environmental constraints are related to limitations imposed on the development in order to preserve the physical condition of watercourses, vegetation, soil cover, as well as protecting against water quantity and quality).	N/A	
Pumping stations: impacts of proposed development on existing pumping stations or requirements for new pumping station to service development.	Y	Report Section 3.3 Existing Sanitary Sewer and Pump Station
Forcemain capacity in terms of operational redundancy, surge pressure and maximum flow velocity.	N/A	
Identification and implementation of the emergency overflow from sanitary pumping stations in relation to the hydraulic grade line to protect against basement flooding.	N/A	
Special considerations such as contamination, corrosive environment etc.	N/A	

**Hard Rock Hotel Casino**  
**4837 Albion Road, Ottawa**  
**DEVELOPMENT SERVICING STUDY CHECKLIST**

4.4 Stormwater	Addressed (Y/N/NA)	Comments
Description of drainage outlets and downstream constraints including legality of outlet (i.e. municipal drain, right-of-way, watercourse, or private property).	Y	Report Section 4.0 Storm Servicing and Stormwater Management
Analysis of the available capacity in existing public infrastructure.	N/A	Storm outlet is to an existing private pond, which ultimately outlets an open ditch system
A drawing showing the subject lands, its surroundings, the receiving watercourse, existing drainage patterns and proposed drainage patterns.	Y	Refer to Stormwater Management Plan
Water quantity control objective (e.g. controlling post-development peak flows to pre-development level for storm events ranging from the 2 or 5 year event (dependent on the receiving sewer design) to 100 year return period); if other objectives are being applied, a rationale must be included with reference to hydrologic analyses of the potentially affected subwatersheds, taking into account long-term cumulative effects.	Y	Report Section 4.0 Storm Servicing and Stormwater Management
Water Quality control objective (basic, normal or enhanced level of protection based on the sensitivities of the receiving watercourse) and storage requirements.	Y	4.0 Storm Servicing and Stormwater Management
Description of stormwater management concept with facility locations and descriptions with references and supporting information.	Y	4.0 Storm Servicing and Stormwater Management
Set-back from private sewage disposal systems.	N/A	
Watercourse and hazard lands setbacks.	N/A	
Record of pre-consultation with the Ontario Ministry of Environment and the Conservation Authority that has jurisdiction on the affected watershed.	N/A	
Confirm consistency with sub-watershed and Master Servicing Study, if applicable study exists.	N/A	
Storage requirements (complete with calcs) and conveyance capacity for 5 yr and 100 yr events.	Y	Refer to Appendix D
Identification of watercourse within the proposed development and how watercourses will be protected, or, if necessary, altered by the proposed development with applicable approvals.	N/A	
Calculate pre and post development peak flow rates including a description of existing site conditions and proposed impervious areas and drainage catchments in comparison to existing conditions.	Y	Refer to Appendix D
Any proposed diversion of drainage catchment areas from one outlet to another.	N/A	
Proposed minor and major systems including locations and sizes of stormwater trunk sewers, and SWM facilities.	N/A	
If quantity control is not proposed, demonstration that downstream system has adequate capacity for the post-development flows up to and including the 100-year return period storm event.	N/A	

**Hard Rock Hotel Casino  
4837 Albion Road, Ottawa  
DEVELOPMENT SERVICING STUDY CHECKLIST**

<b>4.4 Stormwater</b>	<b>Addressed (Y/N/NA)</b>	<b>Comments</b>
Identification of potential impacts to receiving watercourses.	N/A	
Identification of municipal drains and related approval requirements.	N/A	
Description of how the conveyance and storage capacity will be achieved for the development.	Y	4.0 Storm Servicing and Stormwater Management
100 year flood levels and major flow routing to protect proposed development from flooding for establishing minimum building elevations (MBE) and overall grading.	Y	Refer to Stormwater Management Plan
Inclusion of hydraulic analysis including HGL elevations.	N/A	
Description of approach to erosion and sediment control during construction for the protection of receiving watercourse or drainage corridors.	Y	Report Section 5.0 Erosion and Sediment Control Measures
Identification of floodplains – proponent to obtain relevant floodplain information from the appropriate Conservation Authority. The proponent may be required to delineate floodplain elevations to the satisfaction of the Conservation Authority if such information is not available or if information does not match current conditions.	N/A	
Identification of fill constrains related to floodplain and geotechnical investigation.	N/A	

<b>4.5 Approval and Permit Requirements</b>	<b>Addressed (Y/N/NA)</b>	<b>Comments</b>
Conservation Authority as the designated approval agency for modification of floodplain, potential impact on fish habitat, proposed works in or adjacent to a watercourse, cut/fill permits and Approval under Lakes and Rivers Improvement Act. The Conservation Authority is not the approval authority for the Lakes and Rivers Improvement Act. Where there are Conservation Authority regulations in place, approval under the Lakes and Rivers Improvement Act is not required, except in cases of dams as defined in the Act.	N/A	
Application for Certificate of Approval (CofA) under the Ontario Water Resources Act.	N/A	
Changes to Municipal Drains.	N/A	
Other permits (National Capital Commission, Parks Canada, Public Works and Government Services Canada, Ministry of Transportation etc.)	N/A	

<b>4.6 Conclusion</b>	<b>Addressed (Y/N/NA)</b>	<b>Comments</b>
Clearly stated conclusions and recommendations.	Y	Report Section 6.0 Conclusions and Recommendations
Comments received from review agencies including the City of Ottawa and information on how the comments were addressed. Final sign-off from the responsible reviewing agency.	N/A	T.B.D.
All draft and final reports shall be signed and stamped by a professional Engineer registered in Ontario.	Y	

**Appendix F**  
Drawings