

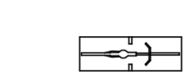





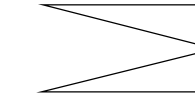

**LEGEND**

-  STORAGE LOCKER  
0.9m x 1.52m
-  STORAGE LOCKER  
0.9m x 1.52m
-  VEHICLE PARKING SPACE  
2.6m X 5.2m

**ROOM LEGEND**

-  STORAGE LOCKER ROOM
-  STORAGE ROOM
-  BICYCLE STORAGE ROOM
-  ELECTRICAL ROOM
-  MECHANICAL / WATER ENTRY ROOM
-  WASTE ROOM

**GENERAL NOTES**

- NOTE-A :** ALL DRAWINGS ARE TO BE READ IN CONJUNCTION WITH ALL OTHER DRAWINGS AND SPECIFICATIONS, INCLUDING OTHER CONSULTANT'S DRAWINGS AND SPECIFICATIONS. ANY DISCREPANCIES BETWEEN DRAWINGS WILL BE REPORTED TO THE PROJECT LEAD IMMEDIATELY FOR CLARIFICATION PRIOR TO COMMENCING ANY CONSTRUCTION.
- NOTE-B :** ALL GENERAL SITE INFORMATION AND CONDITIONS HAVE BEEN COMPILED FROM EXISTING PLANS AND SURVEY.
- NOTE-C :** CONTRACTOR IS RESPONSIBLE TO CHECK AND VERIFY ALL DIMENSIONS ON SITE AND REPORT ALL ERRORS AND / OR OMISSIONS TO THE ARCHITECT.
- NOTE-D :** ALL CONTRACTORS MUST COMPLY WITH ALL CURRENT APPLICABLE CODES, REGULATIONS AND BY-LAWS.
- NOTE-E :** DO NOT SCALE DRAWINGS.

This document and all information herein is confidential and the intellectual property of Rossmann Architects. It is disclosed in confidence on terms that it will not be disclosed to any third party, used, loaned, licensed, or reproduced in whole or in any part in any manner or form for manufacturing, marketing or for any other purpose without the written permission of Rossmann Architects.

The copyright is retained by Rossmann Architects and Associates Inc.

Ce document, ainsi que tous renseignements contenus à l'intérieur, est la propriété de Rossmann Architects. Il est divulgué en confidence sous les termes qu'il ne sera pas divulgué à aucun tiers, utilisé, vendu, prêté, licencié ou reproduit en son entier ou en partie d'aucune manière pour la manufacture, soumission ou pour autres fins sans la permission écrite de Rossmann Architects.

Le droit d'auteur est retenu par Rossmann Architects.



**ROSSMANN ARCHITECTURE**

88 Saint-Joseph  
Boulevard, Gatineau  
QC J8Y 3W5  
819-800-1555

Drawn by / Dessiné par  
Author  
Reviewed by / Révisé par  
Designer

**TEAM / ÉQUIPE**

- PLANNING  
PAQUETTE PLANNING ASS. Ltd.  
T 613.722.7217
- CIVIL  
STANTEK CONSULTING Ltd.  
T 613.722.4420
- STRUCTURAL ENG.  
CPF GROUPE CONSEIL  
T 513.667.5450
- MECHANICAL / ELECTRICAL ENG.  
LCA EXPERT CONSULTANTS  
T 819.243.8383
- LANDSCAPE  
LEVSTEK CONSULTANTS  
T 613.826.0518

Release	Date	Description
1	19/12/13	ISSUED FOR SITE PLAN CONTROL



Revision	Date	Description
2.0	2019-08-29	POUR COORDINATION

**BRIGIL**

19-001  
PETRIE'S LANDING BLOCK 8

PLAN DU SOUS-SOL P1

2019-08-29  
1 : 150

Revision 2.0  
**A100**

#17487

D01-12-19-

