

PROPOSED MIXED-USE RETAIL & RENTAL APARTMENT BUILDING
1050&1060 BANK STREET OTTAWA, ON

SITE SERVICING PLAN

Contract No. **C001**
Sheet No. 1 of 5
Asset No.
Asset Group

Des: DG Chk'd: JF
Dwn: NI Chk'd: JF
Utility Circulation No.: CTY---
Construction Inspector:

Scale: 1:150
0m HORIZONTAL 2.5 5

NOTE:
The location of utilities is approximate only, the exact location should be determined by consulting the municipal authorities and utility companies concerned. The contractor shall prove the location of utilities and shall be responsible for adequate protection from damage.

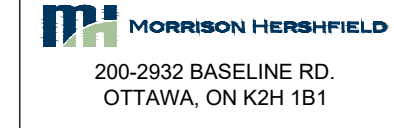

No.	Description	By	Date (dd/mm/yyyy)
0	ISSUED FOR SITE PLAN APPROVAL	J.F.	02/12/19
1	RE-ISSUED FOR SITE PLAN APPROVAL	J.F.	18/06/20

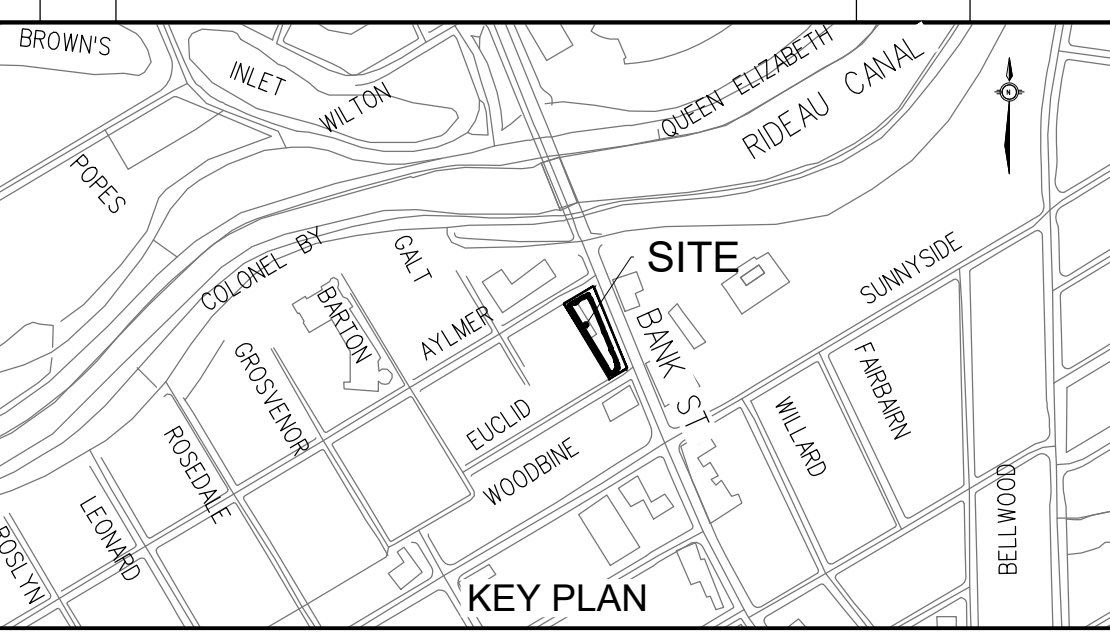

LEGEND

- NEW WATERMAIN
- NEW SANITARY SEWER
- NEW STORM SEWER
- NEW MANHOLE
- VB NEW VALVE AND VALVE BOX
- NEW HYDRANT
- NEW CAP
- NEW CATCH BASIN
- NEW STORM CB LEAD
- ▽ NEW ENTRANCE
- ▽ NEW FIRE DEPARTMENT CONNECTION
- RD NEW ROOF DRAIN
- NEW THERMAL INSULATION FOR SHALLOW SEWERS
- ST EXISTING STORM SEWER
- S EXISTING SANITARY SEWER
- W EXISTING WATERMAIN

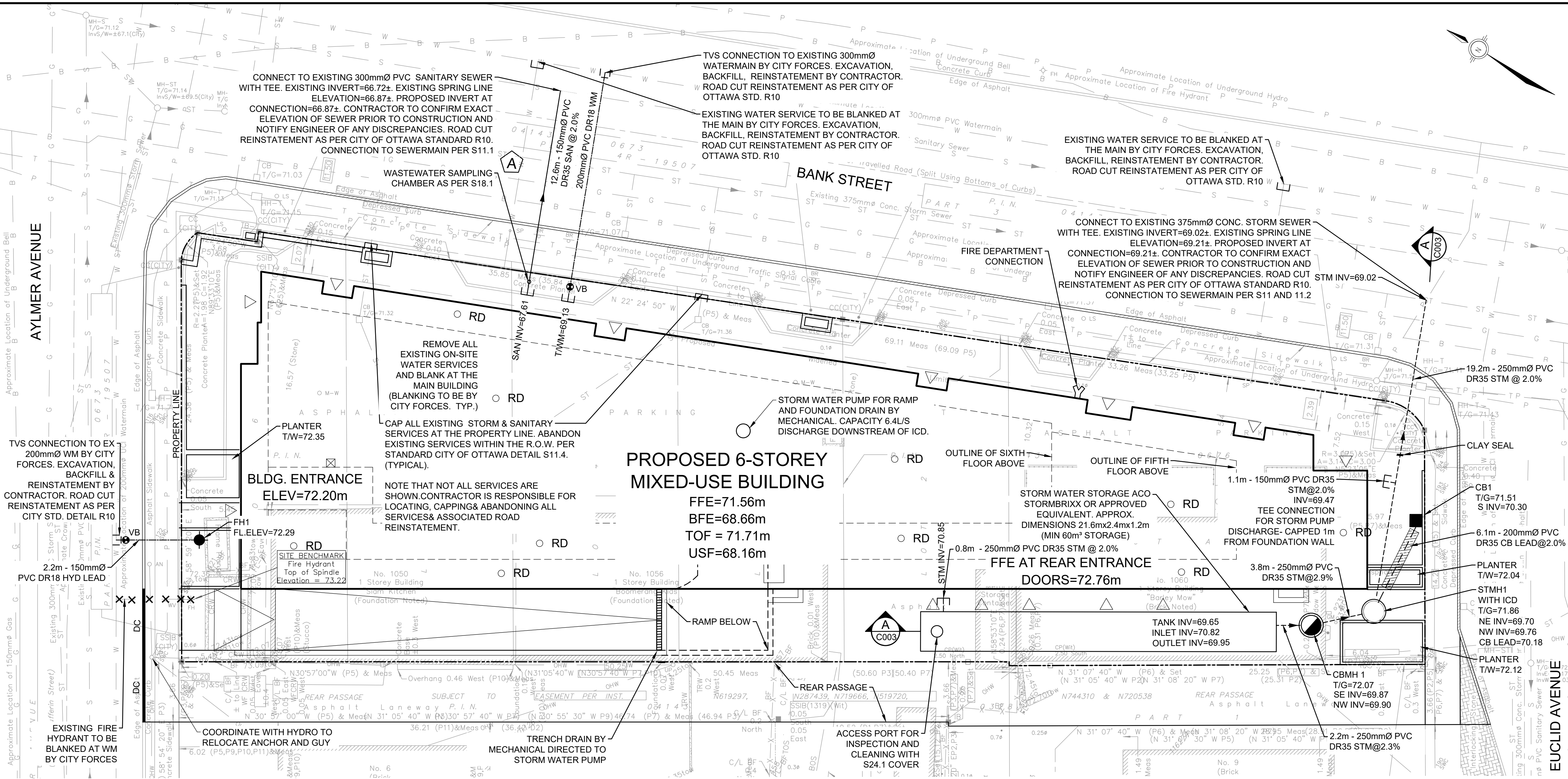

PROPOSED 6-STORY MIXED-USE BUILDING

FFE=71.56m
BFE=68.66m
TOF = 71.71m
USF=68.16m

NOTES:
GENERAL

- COORDINATES ARE IN MTM ZONE 9 (76°30' WEST LONGITUDE) NAD-83 (ORIGINAL)
- OBTAIN ALL NECESSARY PERMITS AND APPROVALS FROM THE CITY OF OTTAWA PRIOR TO STARTING CONSTRUCTION
- ALL MATERIALS AND CONSTRUCTION TO BE IN ACCORDANCE WITH CURRENT CITY OF OTTAWA STANDARDS AND ONTARIO PROVINCIAL STANDARDS AND SPECIFICATIONS (OPSS & OPSD)
- SERVICES ARE TO BE CONSTRUCTED TO 1.0m FROM FACE OF BUILDING
- REFER TO "SITE SERVICING AND STORMWATER MANAGEMENT DESIGN BRIEF, 1050&1060 BANK STREET, MIXED-USE DEVELOPMENT" PREPARED BY MORRISON HERSHFIELD FOR SITE SERVICING REPORT
- REFER TO GEOTECHNICAL INVESTIGATION REPORT (NO. PG4506-1 DATED APRIL 8, 2020) PREPARED BY PATERSON GROUP FOR SUBSURFACE CONDITIONS, CONSTRUCTION RECOMMENDATIONS AND GEOTECHNICAL INSPECTION REQUIREMENTS. THE GEOTECHNICAL CONSULTANT SHALL REVIEW EXCAVATIONS PRIOR TO THE PLACEMENT OF GRANULAR MATERIAL.
- CONTRACTOR TO VERIFY ALL EXISTING UTILITY ELEVATIONS AT CONNECTION AND CROSSING LOCATIONS PRIOR TO CONSTRUCTION AND ADVISE THE ENGINEER OF ANY DISCREPANCIES.
- UNLESS DIRECTED OTHERWISE ANY DAMAGED ASPHALT OR CURB (REGARDLESS OF WHETHER WITHIN OR EXTERNAL TO THE SITE) SHALL BE REINSTATED IN ACCORDANCE WITH CITY STD. DET. R10 AND S1.
- UNLESS DIRECTED OTHERWISE THE CONTRACTOR SHALL REINSTATE ALL SIGNS, LIGHTING AND OTHER STREET FURNITURE DISTURBED BY THE WORK
- THE CONTRACTOR SHALL DEVELOP AND IMPLEMENT TRAFFIC MANAGEMENT PLANS FOR WORK IN RIGHT OF WAY IN ACCORDANCE WITH OTM BOOK 7.

- CLAY SEALS SHALL BE IN ACCORDANCE WITH CITY OF OTTAWA STANDARD DETAIL S8 AND SHALL BE INSTALLED AT 50m INTERVALS IN ALL PIPE TRENCHES. CLAY SEAL TO EXTEND FULL TRENCH WIDTH AND FROM BOTTOM OF TRENCH EXCAVATION TO UNDERSIDE OF ROAD STRUCTURE, WITH A MINIMUM THICKNESS OF 1m ALONG PIPE.
- LOCATE AND CAP ALL EXISTING STORM, SANITARY AND WATER SERVICES AT THE PROPERTY LINE. ABANDON EXISTING SERVICES WITHIN THE R.O.W. PER STANDARD CITY OF OTTAWA DETAIL S11.4 (TYPICAL).
- REFER TO ARCHITECTURAL DRAWINGS FOR EXACT ROOF DRAINAGE LAYOUT.

SEWERS

- ALL STORM SEWERS, SANITARY SEWERS AND CATCH BASINS LEADS SHALL BE PVC DR 35 UNLESS OTHERWISE SPECIFIED.
- REFER TO DETAIL 1 ON DRAWING C003 FOR SEWER INSTALLATION.
- MAINTENANCE HOLES AND CATCH BASIN MAINTENANCE HOLES ON STORM SEWERS LESS THAN 900mm DIAMETER SHALL BE CONSTRUCTED WITH A 300mm SUMP. BENCHING SHALL BE INSTALLED IN MAINTENANCE HOLES ON STORM SEWERS 900mm AND ABOVE.
- STORM SEWER MAINTENANCE HOLE COVERS SHALL BE IN ACCORDANCE WITH CITY OF OTTAWA STANDARD DETAIL S24.1 ON FRAMES TO DETAIL S25.
- CONTRACTOR SHALL MAINTAIN EXISTING SEWER FLOWS DURING CONSTRUCTION IN ACCORDANCE WITH CITY OF OTTAWA SPECIFICATIONS.
- ALL MAINTENANCE HOLES, CATCH BASINS AND CLEANOUTS SHALL BE ADJUSTED TO POST-CONSTRUCTION GRADE.
- CCTV INSPECTION OF ALL SEWERS SHALL BE COMPLETED AS PER CITY OF OTTAWA SPECIFICATIONS PRIOR TO THE INSTALLATION OF BASE COURSE ASPHALT.
- BACKWATER VALVES TO BE INSTALLED AS PER CITY OF OTTAWA STANDARD S14 & S14.2.

WATERMAINS

- REFER TO DETAIL 1 ON DRAWING C003 FOR WATERMAIN INSTALLATION.
- ALL WATERMAIN MATERIALS AND CONSTRUCTION METHODS SHALL BE IN ACCORDANCE WITH THE 2019 EDITION OF THE CITY OF OTTAWA STANDARD SPECIFICATIONS AND STANDARD DRAWINGS. PVC PIPE TO BE CLASS 150 DR18 TO LATEST EDITION OF A.W.W.A. SPECIFICATION C900 AND CSA B137.3 LATEST AMENDMENT WITH GASKETED BELL AND SPIGOT COUPLINGS.
- THE CONTRACTOR SHALL BE RESPONSIBLE FOR OBTAINING A WATER PERMIT AS REQUIRED FROM THE CITY OF OTTAWA, AND COMPLYING WITH ALL CITY OF OTTAWA REQUIREMENTS. THE CITY MAY REQUIRE THAT CERTAIN ACTIVITIES (E.G. VALVE OPERATION, CONNECTION OF NEW WATER SERVICE TO EXISTING WATERMAIN, DISINFECTION) BE CARRIED OUT ONLY BY CITY FORCES
- ALL VALVES 300mm DIAMETER AND SMALLER SHALL INCLUDE A VALVE BOX AS PER W24.
- THE NEW WATERMAIN IS TO BE INSTALLED WITH A MINIMUM OF 2.4m COVER (INCLUDING HYDRANT LEAD), WHERE 2.4m COVER IS NOT POSSIBLE, PROVIDE INSULATION IN ACCORDANCE WITH CITY OF OTTAWA STANDARD DETAILS W22 & W23.
- THRUST RESTRAINT SHALL BE PROVIDED BY BOTH RESTRAINING/RETAINING RINGS AND THRUST BLOCKS AT ALL DEAD END CAPS, PLUGS, VALVES, BENDS AND REDUCERS AS PER CITY OF OTTAWA STANDARD DETAILS W25.3, W25.4, W25.5 AND W25.6. ALL TEMPORARY THRUST RESTRAINTS ARE THE RESPONSIBILITY OF THE CONTRACTOR.
- TRACER WIRE SHALL BE PROVIDED FOR ALL NEW PVC WATERMAINS IN ACCORDANCE WITH THE SPECIFICATIONS AND CITY OF OTTAWA STANDARD DETAIL W36.
- CATHODIC PROTECTION SHALL BE PROVIDED FOR ALL NEW WATERMAINS IN ACCORDANCE WITH THE SPECIFICATIONS AND CITY OF OTTAWA STANDARD DETAILS W39, W40, W41, W42 AND W47. CATHODIC PROTECTION OF EXISTING WATERMAINS SHALL ALSO BE PROVIDED AT CONNECTIONS BETWEEN EXISTING AND NEW WATERMAINS.
- ADJUST ALL VALVE CHAMBERS, VALVE BOXES AND HYDRANTS TO FINISHED GRADE.

UTILITY NOTE

- THE POSITION OF POLE LINES, CONDUITS, WATERMAINS, SEWERS AND OTHER UNDERGROUND AND OVERGROUND UTILITIES AND STRUCTURES IS NOT NECESSARILY SHOWN ON THE CONTRACT DRAWING, AND, WHERE SHOWN, THE ACCURACY OF THE POSITION OF SUCH UTILITIES AND STRUCTURES IS NOT GUARANTEED. BEFORE STARTING WORK THE CONTRACTOR SHALL INFORM HIMSELF OF THE EXACT LOCATION OF ALL SUCH UTILITIES AND STRUCTURES, AND SHALL ASSUME ALL LIABILITY FOR DAMAGE TO THEM. THE CONTRACTOR WILL BE RESPONSIBLE FOR SUPPORTING AND PROTECTING ANY EXISTING UTILITIES, AS REQUIRED, IN ACCORDANCE WITH THE UTILITY OWNERS' REQUIREMENTS. CONTRACTOR IS REQUIRED TO OBTAIN LOCATES, IN ADVANCE OF EXCAVATION WORK, AND FORWARD COPIES OF THE LOCATES TO THE CONSULTANT AND THE OWNER PRIOR TO EXCAVATION.
- ALL CROSSING OF EX. UTILITIES TO BE IN ACCORDANCE WITH CITY STD. DET. S10

PIPE CROSSING TABLE

CROSSING	LOWER PIPE	HIGHER PIPE	CLEARANCE	SURFACE ELEVATION
A	150mmØ SAN OBV=66.94	375mmØ STM INV=69.28	2.3m±	71.09m

PROPOSED HYDRANT LEAD TABLE

STATION	SURFACE ELEVATION	T/WM ELEVATION	COMMENTS
0+000	72.04	69.64±*	TVS CONNECTION TO EXISTING 200mmØ WATERMAIN
0+001.5	72.18	69.78±	200mmØ VALVE AND VALVE BOX
0+003.0	72.23	69.83±	HYDRANT

PROPOSED WATER SERVICE TABLE

STATION	SURFACE ELEVATION	T/WM ELEVATION	COMMENTS
0+000	71.70	68.70±*	TVS CONNECTION TO EXISTING 300mmØ WATERMAIN
0+001.5	71.11	68.71±	CROSS ABOVE 300mmØ SAN (1.7m± CLEARANCE)
0+005.9	71.10	68.70±	CROSS ABOVE 375mmØ STM (0.6m± CLEARANCE)
0+013.0	71.48	69.08±	200mmØ VALVE AND VALVE BOX
0+014.6	71.53	69.13±	CAP 1.0m FROM BUILDING FACE

* TVS CONNECTION TO EXISTING 300mmØ WATERMAIN. EXACT ELEVATION TO BE FIELD DETERMINED.

NEW STORM STRUCTURE

STRUCTURE	STRUCTURE TYPE	COVER TYPE	TOP OF GRATE	INVERT	NORTHING	EASTING	NOTES
MHST1	701.010	S24.1	71.86	69.70 (NE) 69.76 (NW)	5028644.29	368687.58	WITH ICD
CBMH1	701.010	S19	72.07	69.90 (NW) 69.87 (SE)	5028647.12	368684.90	
CB1	705.010	S19	71.51	70.30 (SW)	5028644.91	368693.63	

INLET CONTROL DEVICE DATA TABLE - STMH1

DESIGN EVENT	ICD TYPE	DIAMETER OF OUTLET PIPE (mm)	DESIGN FLOW (L/s)	WATER ELEVATION (m)	REQUIRED VOLUME (m³)	TOTAL VOLUME PROVIDED
1:5 YR	IPEX Tempest LMF 50	250mmØ PVC	2.0	70.73	31.9	60m³
1:100 YR	IPEX Tempest LMF 50	250mmØ PVC	2.4	71.15	59.0	

Drawing Frame: 790mm x 554mm City of Ottawa, 2008 (Rev.0)
 Plot Date: Friday, June 19, 2020 9:16:41 AM
 Last Saved: Friday, June 19, 2020 8:52:27 AM
 Consultants' Information: \\m:\local\dean\proj\2019\1050-1060-Bank-Street-Civil\09_CAD\07-Sheets\Grading Plan.dwg

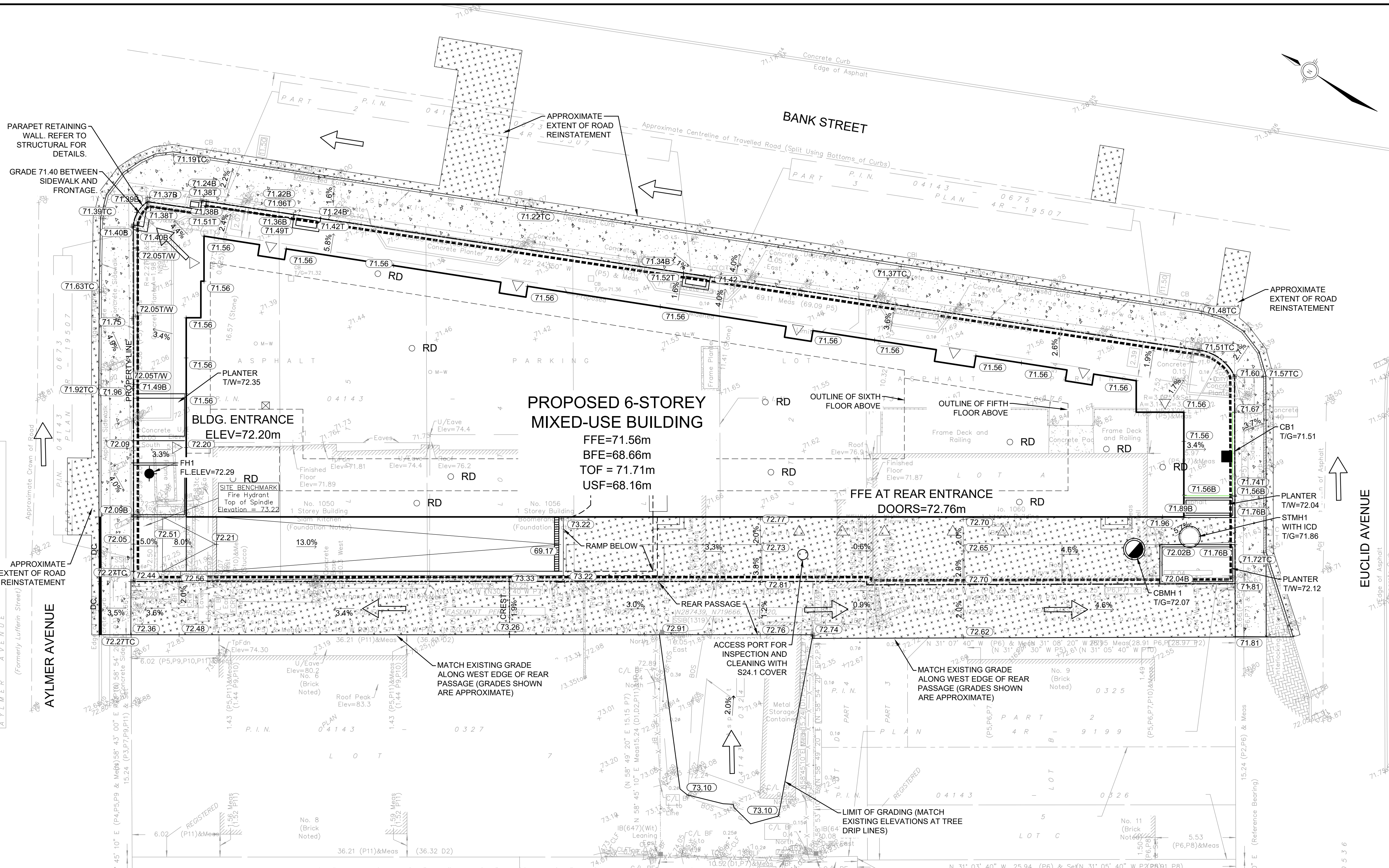

PROPOSED MIXED-USE RETAIL & RENTAL APARTMENT BUILDING 1050&1060 BANK STREET OTTAWA, ON	
Contract No.	Drawing No. C002
Sheet No. 2	of 5
Asset No.	
Asset Group	
Des: DG	Chk'd: JF
Dwn: NI	Chk'd: JF
Utility Circulation No.: CTY---	
Construction Inspector:	
Scale: 1:150	
0m HORIZONTAL 2.5 5	

NOTE:
 The location of utilities is approximate only, the exact location should be determined by consulting the municipal authorities and utility companies concerned. The contractor shall prove the location of utilities and shall be responsible for adequate protection from damage.

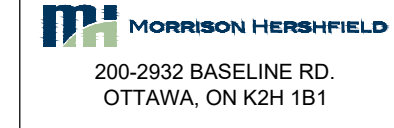

No.	Description	By	Date (dd/mm/yy)
0	ISSUED FOR SITE PLAN APPROVAL	J.F.	02/12/19
1	RE-ISSUED FOR SITE PLAN APPROVAL	J.F.	18/06/20

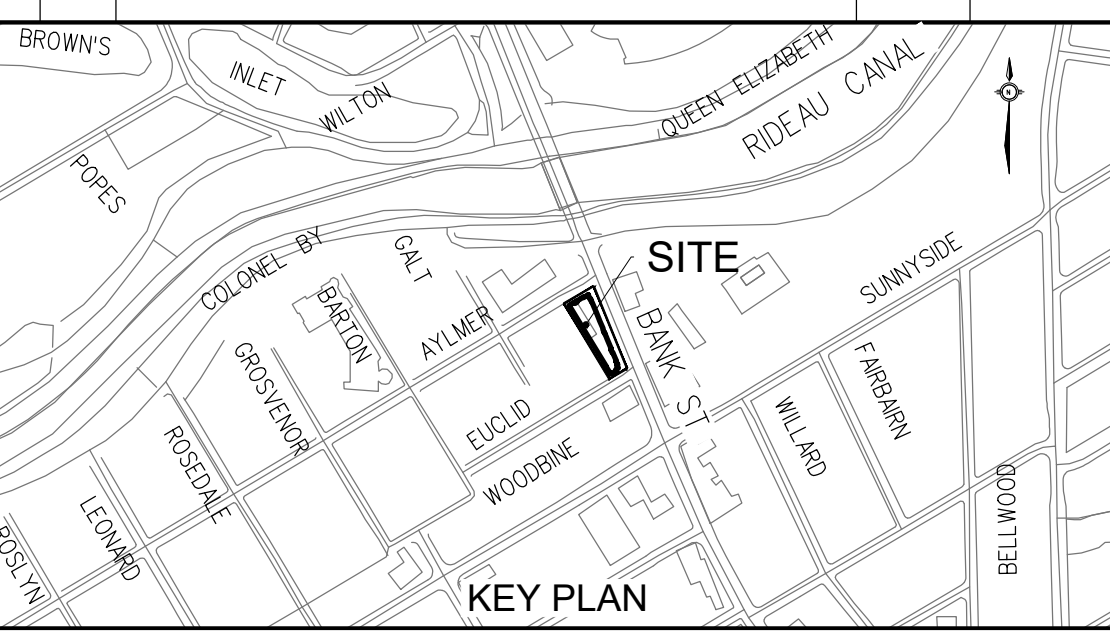

LEGEND

- × (71.40) PROPOSED ELEVATION
- × 71.65 EXISTING ELEVATION
- × (71.40T) PROPOSED FINISH GRADE AT TOP OF WALL OR STEP
- × (71.40B) PROPOSED FINISH GRADE AT BOTTOM OF WALL OR STEP
- × (71.40TC) PROPOSED TOP OF CURB ELEVATION
- ↘ 2.0% PROPOSED SLOPE DIRECTION
- ➔ DIRECTION OF MAJOR OVERLAND FLOW
- PROPOSED CURB
- DC PROPOSED DEPRESSED CURB
- LIGHT DUTY SILT FENCE
- ▨ HEAVY DUTY PAVEMENT (SEE DRAWING C003 FOR DETAILS)
- ▨ CONCRETE SIDEWALK (REFER TO LANDSCAPE)

NOTES:
GRADING

- ALL ELEVATIONS ARE GEODETIC.
- REFER TO ARCHITECTURAL AND LANDSCAPE DRAWINGS FOR LAYOUT, DIMENSIONS AND SURFACE FINISHES.
- THIS DRAWING SHALL BE READ IN CONJUNCTION WITH ALL OTHER DRAWINGS.
- ALL ELEVATIONS BY CURBS ARE EDGE OF PAVEMENT UNLESS OTHERWISE INDICATED.
- REFER TO GEOTECHNICAL INVESTIGATION REPORT (NO. PG4506-1 DATED APRIL 8, 2020) PREPARED BY PATERSON GROUP FOR SUBSURFACE CONDITIONS, CONSTRUCTION RECOMMENDATIONS AND GEOTECHNICAL INSPECTION REQUIREMENTS. THE GEOTECHNICAL CONSULTANT SHALL REVIEW EXCAVATIONS PRIOR TO THE PLACEMENT OF GRANULAR MATERIAL.
- REINSTATE ALL DISTURBED/DAMAGED AREAS TO THEIR ORIGINAL CONDITION OR BETTER.
- PROVIDE POSITIVE DRAINAGE, MATCHING EXISTING OVERALL DRAINAGE PATTERN INDICATED.
- ALL WORK AND MATERIALS SHALL BE IN ACCORDANCE WITH CITY OF OTTAWA AND/OR ONTARIO PROVINCIAL STANDARDS.
- ALL TOPSOIL, ORGANIC OR DELETERIOUS MATERIAL MUST BE ENTIRELY REMOVED FROM BENEATH THE PROPOSED PAVED AREAS AS DIRECTED BY THE OWNER'S REPRESENTATIVE.
- ALL AREAS SHALL DRAIN AT A MINIMUM OF 1%. ANY DISCREPANCIES PREVENTING THIS SHALL BE REPORTED TO THE ENGINEER PRIOR TO CONTINUING WORK.

- BLEND NEW EARTHWORK INTO EXISTING, PROVIDING VERTICAL CURVES OR ROUNDING AT ALL TOP AND BOTTOM OF SLOPES.
- ALL SIDEWALKS CONSTRUCTED IN CITY ROW. SHALL BE MONOLITHIC CONCRETE CURB AND SIDEWALK PER STD. DETAIL SC 2 UNLESS OTHERWISE INDICATED.
- SAW CUT AND KEY GRIND ASPHALT AT ALL TIE-INS PER CITY OF OTTAWA STANDARD R10.
- PROVIDE LINE PAINTING.
- SNOW IS TO BE REMOVED FROM THE SITE. ON SITE SNOW STORAGE IS NOT PROPOSED.
- TOP OF FOUNDATION TO BE 0.15m ABOVE FINISHED GRADE.

EROSION AND SEDIMENT CONTROL

- THE CONTRACTOR SHALL IMPLEMENT BEST MANAGEMENT PRACTICES, TO PROVIDE FOR PROTECTION OF THE AREA DRAINAGE SYSTEM AND THE RECEIVING WATERCOURSE, DURING CONSTRUCTION ACTIVITIES. THIS INCLUDES LIMITING THE AMOUNT OF EXPOSED SOIL, USING FILTER CLOTH UNDER THE GRATES OF CATCHBASINS AND MANHOLES, AND INSTALLING SILT FENCES AND OTHER EFFECTIVE SEDIMENT TRAPS. THE CONTRACTOR ACKNOWLEDGES THAT FAILURE TO IMPLEMENT APPROPRIATE EROSION AND SEDIMENT CONTROL MEASURES MAY BE SUBJECT TO PENALTIES IMPOSED BY ANY APPLICABLE REGULATORY AGENCY.
- THE SEDIMENT CONTROL MEASURES SHALL ONLY BE REMOVED WHEN, IN THE OPINION OF THE ENGINEER, THE MEASURES ARE NO LONGER REQUIRED. NO CONTROL MEASURES MAY BE PERMANENTLY REMOVED WITHOUT PRIOR AUTHORIZATION FROM THE ENGINEER.

- REGULAR INSPECTION AND MAINTENANCE OF THE EROSION AND SEDIMENT MEASURES SHALL BE UNDERTAKEN. THE IMPLEMENTATION AND ADJUSTMENT AND/OR CORRECTIVE MAINTENANCE OF THE EROSION AND SEDIMENT MEASURES IS AN INTEGRAL PART OF THE PLAN AND MUST BE PERFORMED.
- GEOTEXTILE FILTER FABRIC SHALL BE PLACED BETWEEN THE STRUCTURE FRAME AND COVER FOR ALL MANHOLES, CATCHBASINS, AND CATCHBASIN MANHOLES IN THE VICINITY OF WORK.
- THE CONTRACTOR SHALL MAINTAIN ADJACENT ROADS IN A CLEAN CONDITION AT ALL TIMES.
- PROVIDE MUD MATS AT SITE CONSTRUCTION ENTRANCE(S) AND EGRESS(S).

UTILITY NOTE

- THE POSITION OF POLE LINES, CONDUITS, WATERMANS, SEWERS AND OTHER UNDERGROUND AND OVERGROUND UTILITIES AND STRUCTURES IS NOT NECESSARILY SHOWN ON THE CONTRACT DRAWING, AND, WHERE SHOWN, THE ACCURACY OF THE POSITION OF SUCH UTILITIES AND STRUCTURES IS NOT GUARANTEED. BEFORE STARTING WORK THE CONTRACTOR SHALL INFORM HIMSELF OF THE EXACT LOCATION OF ALL SUCH UTILITIES AND STRUCTURES, AND SHALL ASSUME ALL LIABILITY FOR DAMAGE TO THEM. THE CONTRACTOR WILL BE RESPONSIBLE FOR SUPPORTING AND PROTECTING ANY EXISTING UTILITIES, AS REQUIRED, IN ACCORDANCE WITH THE UTILITY OWNERS' REQUIREMENTS. CONTRACTOR IS REQUIRED TO OBTAIN LOCATES, IN ADVANCE OF EXCAVATION WORK, AND FORWARD COPIES OF THE LOCATES TO THE CONSULTANT AND THE OWNER PRIOR TO EXCAVATION. HAND EXCAVATION IS REQUIRED PER UTILITY OWNERS REQUIREMENTS.

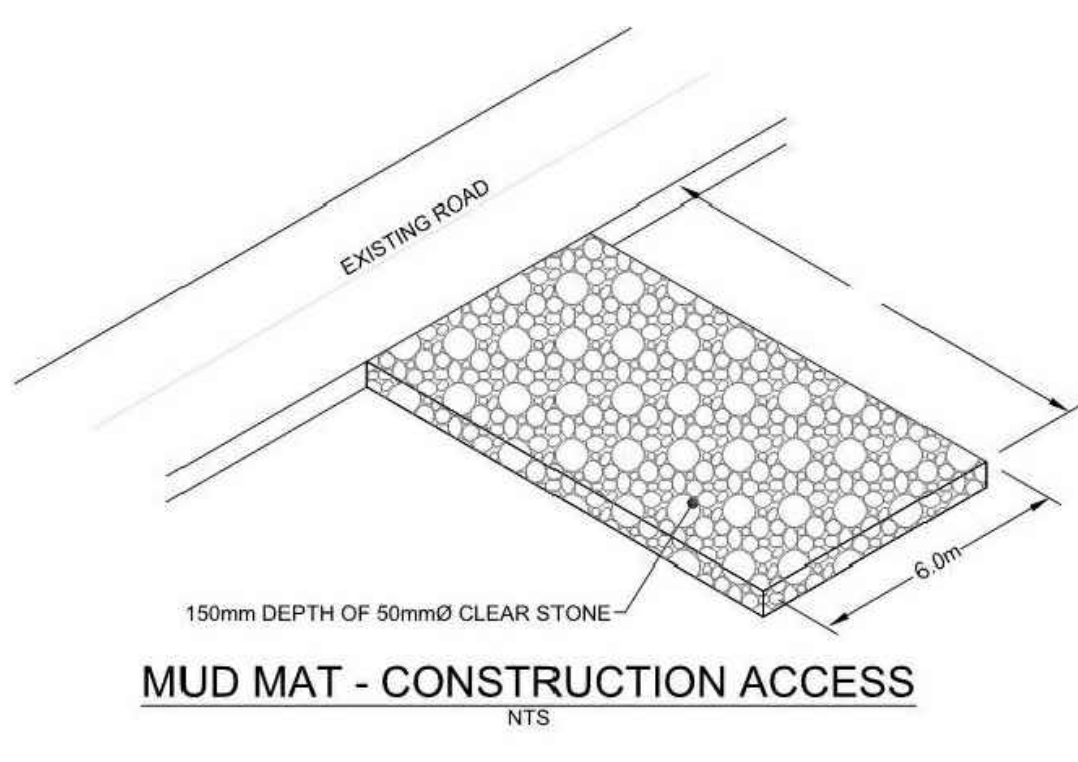

PROPOSED MIXED-USE RETAIL & RENTAL APARTMENT BUILDING
1050&1060 BANK STREET
OTTAWA, ON

Contract No. _____ Drawing No. **C003**

Sheet No. 3 of 5

Asset No. _____

Asset Group _____

Des: DG Chk'd: JF
Dwn: NI Chk'd: JF

Utility Circulation No.: CTY-____

Construction Inspector: _____

Scale: _____

NOTE:
The location of utilities is approximate only, the exact location should be determined by consulting the municipal authorities and utility companies concerned. The contractor shall prove the location of utilities and shall be responsible for adequate protection from damage.

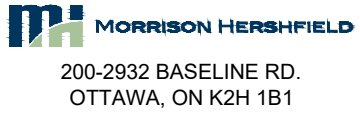

No.	Description	By	Date (dd/mm/yy)
0	ISSUED FOR SITE PLAN APPROVAL	J.F.	02/12/19
1	RE-ISSUED FOR SITE PLAN APPROVAL	J.F.	18/06/20

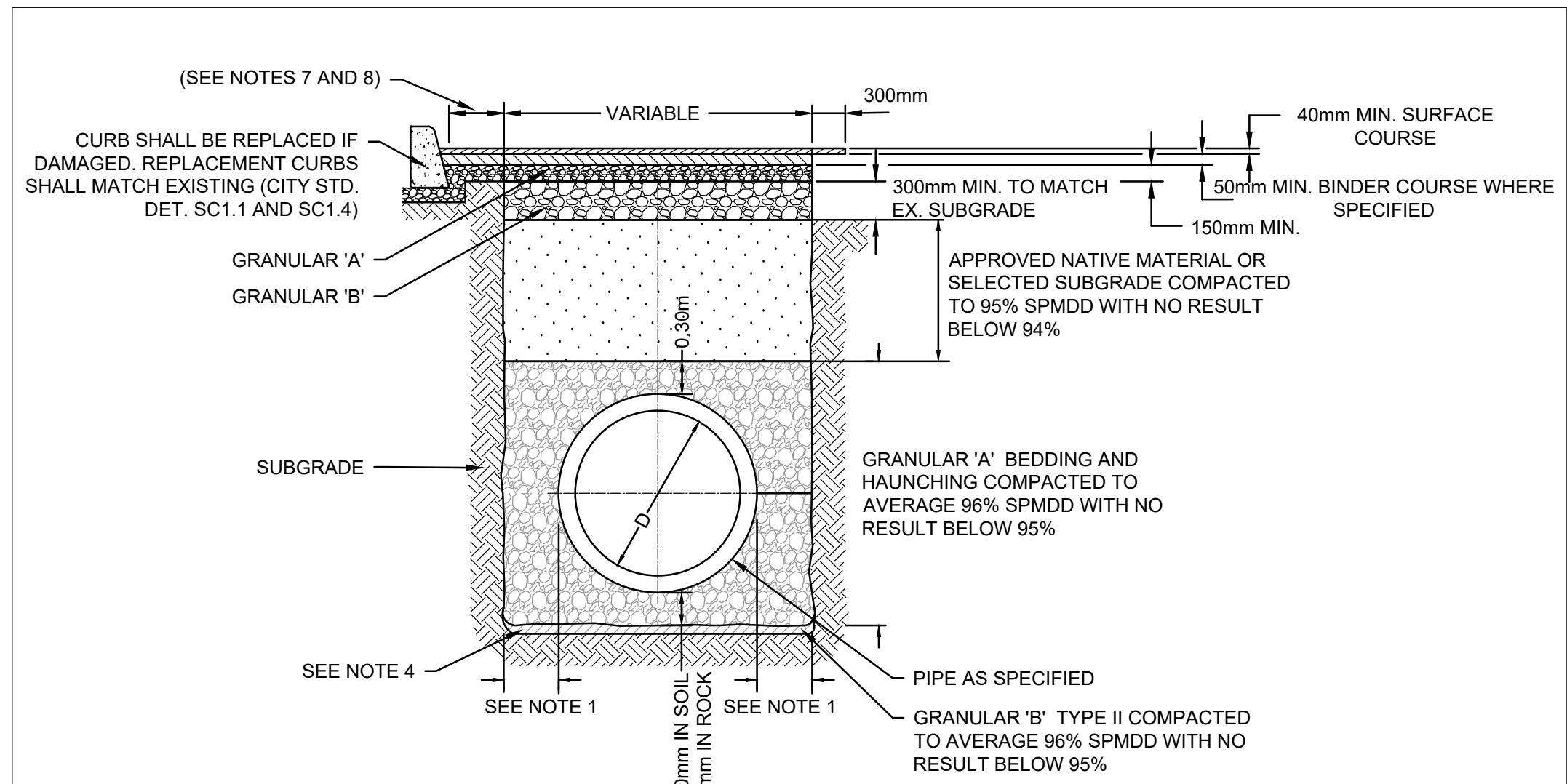
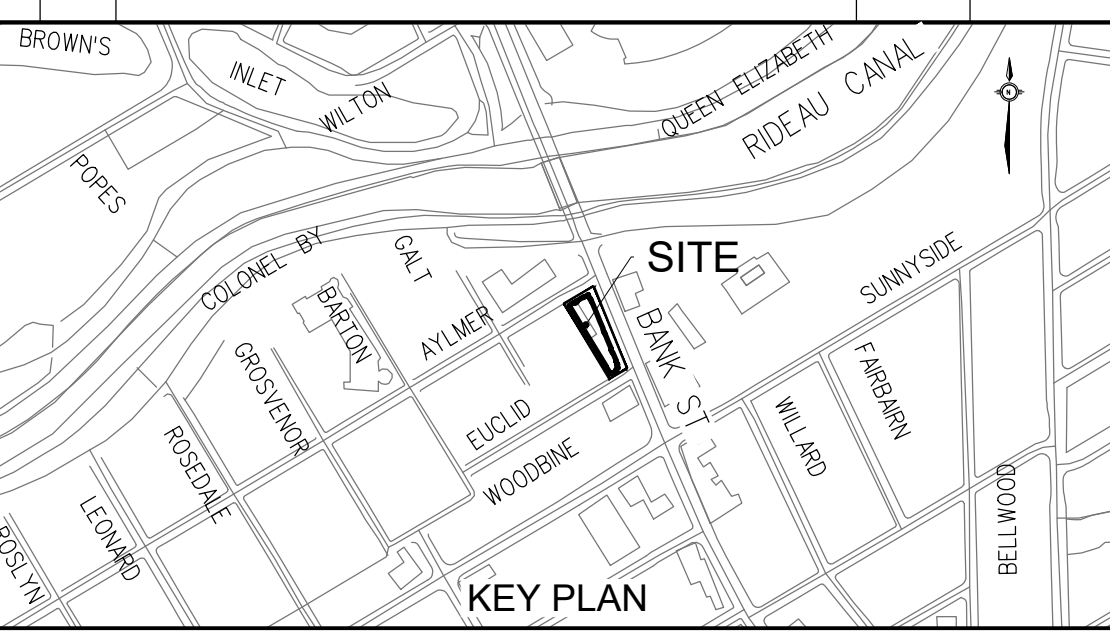
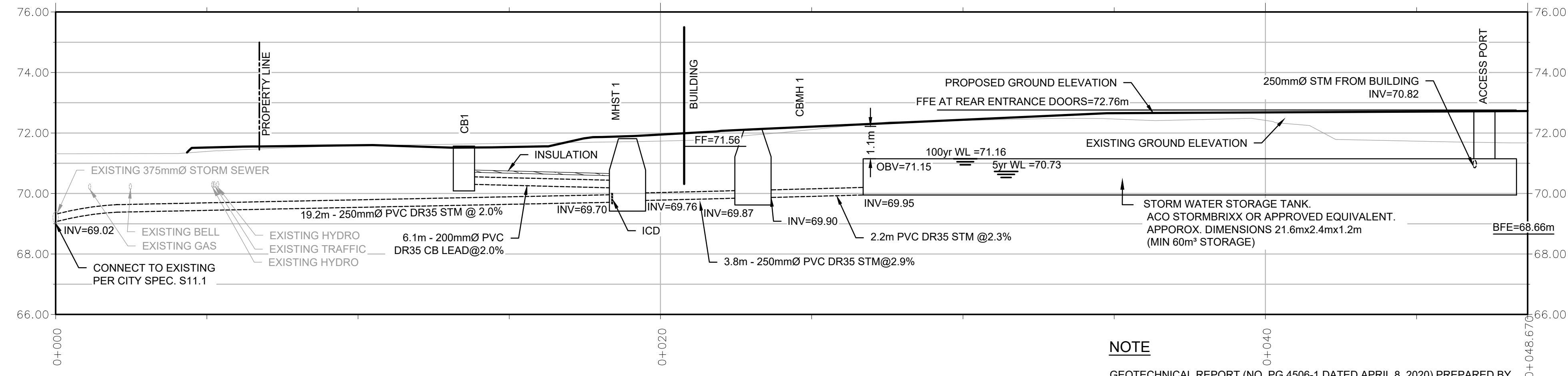

NOTES:

- | PIPE INSIDE DIAMETER (mm) | CLEARANCE (mm) |
|---------------------------|---------------------|
| 900 OR LESS | CONC 450
PVC 450 |
| OVER 900 | 500 |
- FINAL BACKFILL - APPROVED NATIVE MATERIAL OR SELECT SUBGRADE
- ALL DIMENSION ARE IN MILLIMETERS UNLESS SHOWN OTHERWISE.
- WHEN NECESSARY POOR SOILS SHALL BE EXCAVATED TO CREATE A FOUNDATION THAT SHALL BE FILLED TO THE BOTTOM OF THE BEDDING WITH GRANULAR 'B'.
- THE USE OF CLEAR CRUSHED STONE AS A BEDDING LAYER IS NOT PERMITTED ANYWHERE ON THIS SITE.
- ALL EXISTING ASPHALT AND CONCRETE REMOVAL LIMITS TO BE SAWCUT.
- 300 MM KEY TO BE SAWCUT AND REMOVED OR MILLED.
- ROAD REINSTATEMENT ON THE CURB SIDE OF THE TRENCH EXCAVATION SHALL EXTEND TO THE CURB FACE.
- TACK COAT SHALL BE APPLIED TO ALL MILLED SURFACES

1 WATERMAIN AND SEWER INSTALLATION
C001
TYPICAL DETAIL
N.T.S.

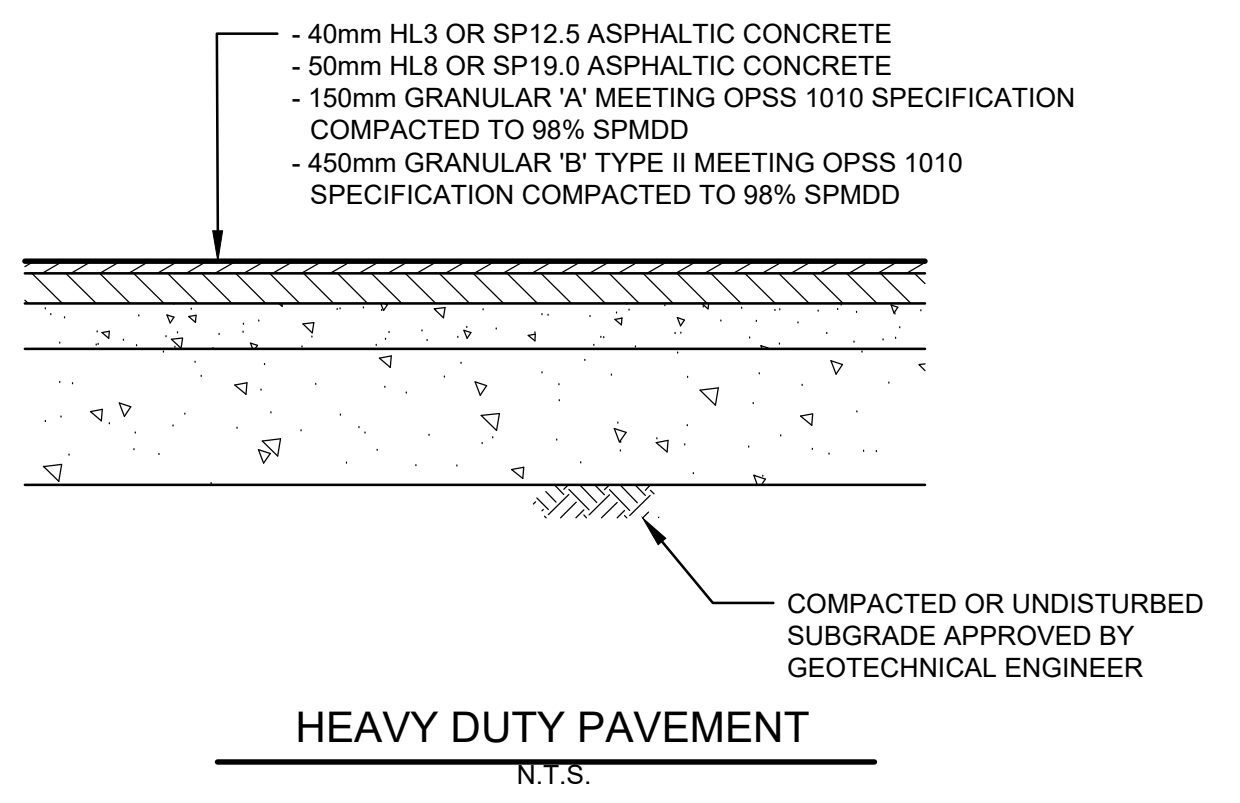

INSULATION NOTE

THE THICKNESS OF SEWER INSULATION SHALL BE THE EQUIVALENT OF 25mm FOR EVERY 300mm REDUCTION IN THE REQUIRED DEPTH OF COVER LESS THAN 1500mm (SEE TABLE BELOW)

TI=THICKNESS OF INSULATION (mm)
H=DEPTH OF COVER
W=D+300 (1000 MIN.)
W=WIDTH OF INSULATION (mm)
D=O.D. OF PIPE (mm)

COVER (mm)	INSULATION THICKNESS (mm)
1500-1200	75
1200-900	100
900-600	125

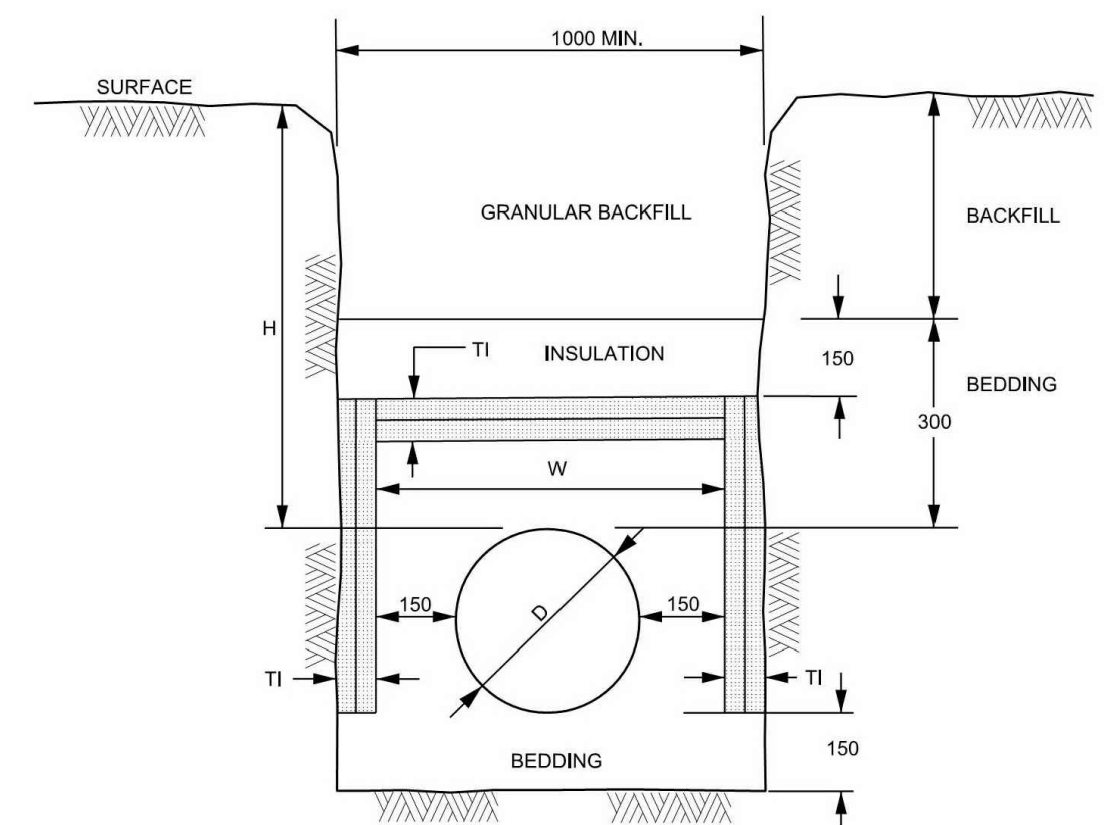



1050 AND 1060 BANK STREET EXISTING STORM DRAINAGE AREA PLAN

LEGEND

AREA ID
RUNOFF COEFFICIENT %

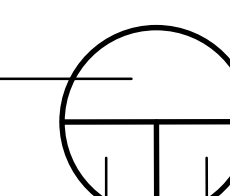

DRAINAGE AREA CHARACTERISTICS
AREA ha

C004

DATE: 2020-06-18

SCALE: N.T.S.

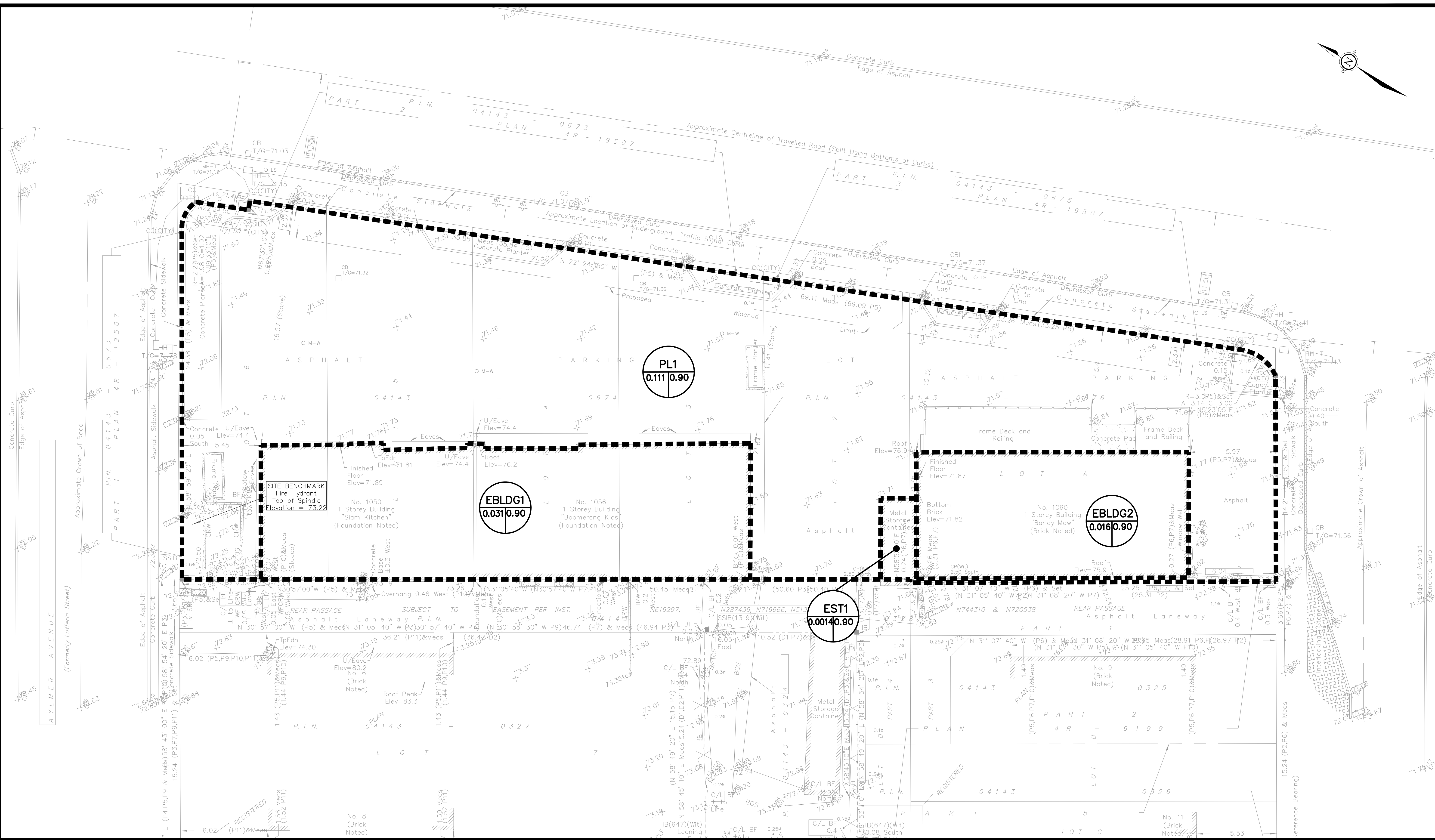

2020-Jun-18 9:21:35 PM P:\2019\190500700-1050-1060 Bank Street-Civil\09_CAD\07 Sheets\Proposed Catchment Areas.dwg



1050 AND 1060 BANK STREET PROPOSED STORM DRAINAGE AREA PLAN

LEGEND

AREA ID

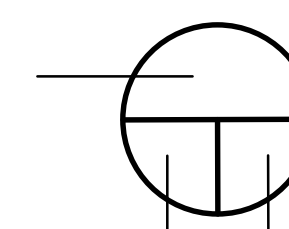

DRAINAGE AREA CHARACTERISTICS

RUNOFF COEFFICIENT %

AREA ha

C005

DATE: 2020-06-18

SCALE: N.T.S.

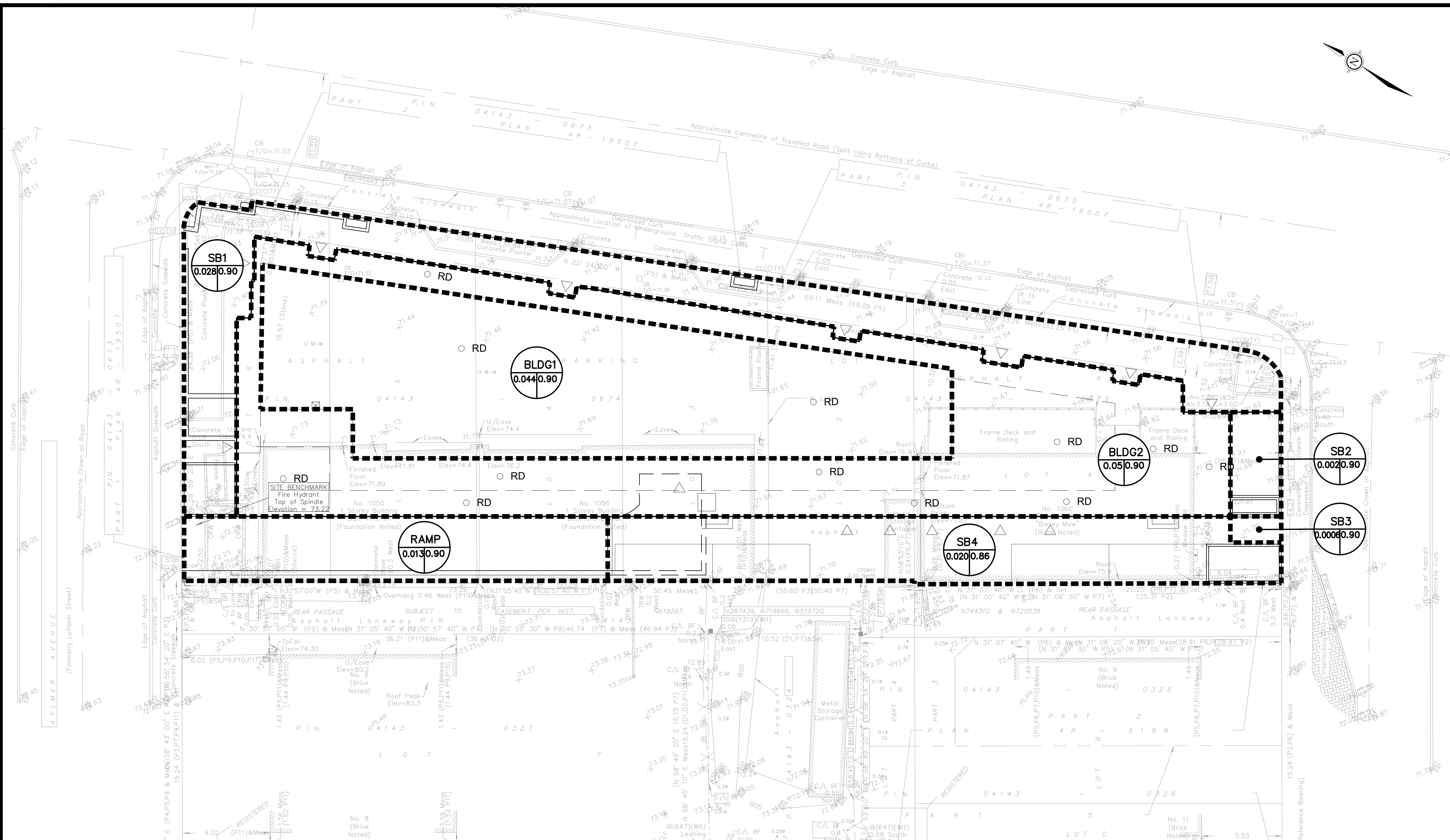

PROPOSED MIXED-USE RETAIL & RENTAL APARTMENT BUILDING
1050&1060 BANK STREET
OTTAWA, ON

Contract No. Drawing No. C100

Sheet No. of 5

Asset No. Asset Group

Des: DG Chk'd: JF

Dwn: NI Chk'd: JF

Utility Construction No.: CTY---

Construction Inspector: Scale:

NOTE:
The location of utilities is approximate only, the exact location should be determined by consulting the municipal authorities and utility companies concerned. The contractor shall prove the location of utilities and shall be responsible for adequate protection from damage.

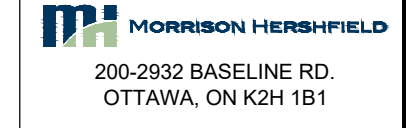

200-2932 BASELINE RD.
OTTAWA, ON K2H 1B1

No.	Description	By	Date (dd/mm/yy)
0	ISSUED FOR SITE PLAN APPROVAL	J.F.	02/12/19
1	RE-ISSUED FOR SITE PLAN APPROVAL	J.F.	18/06/20

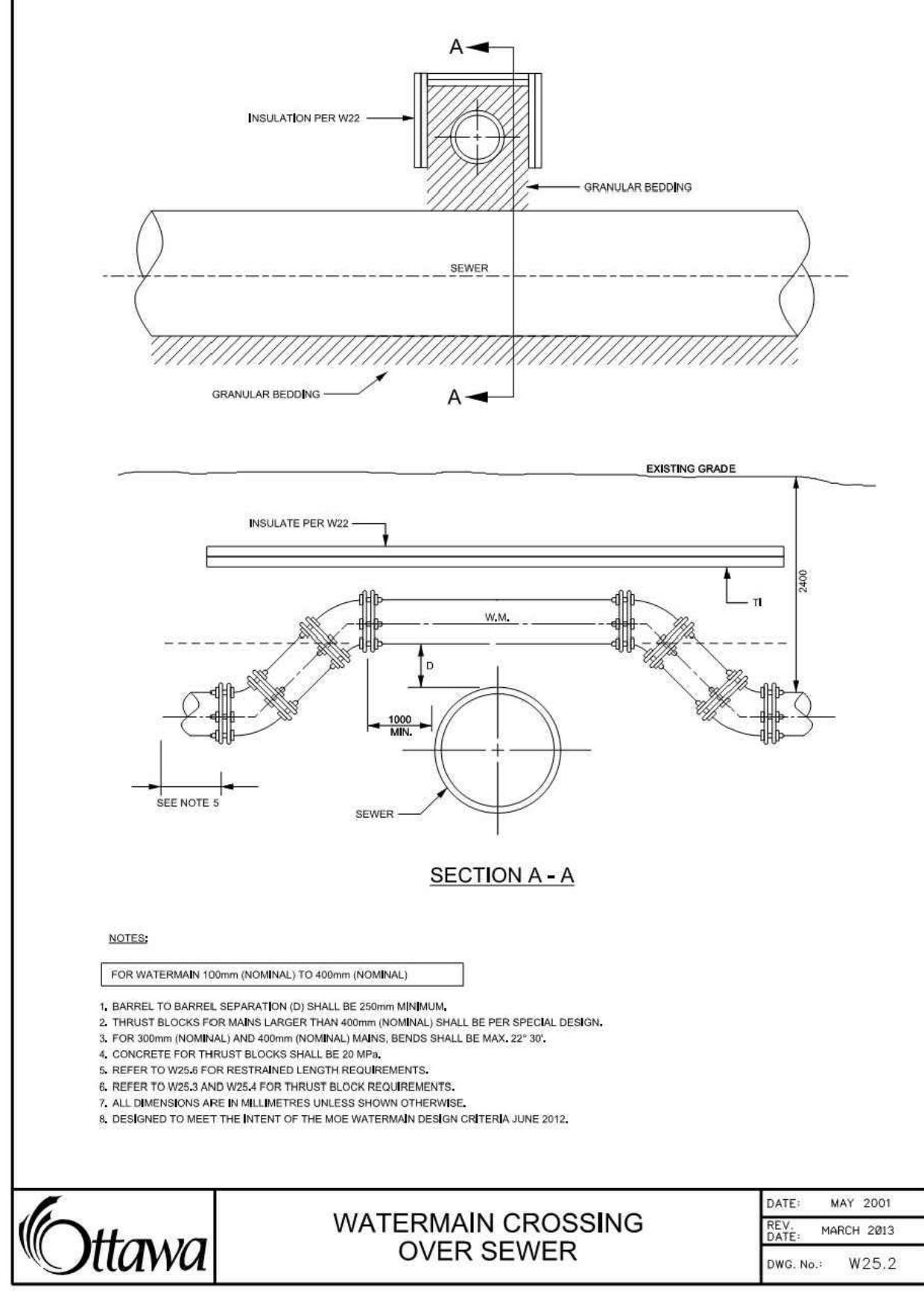
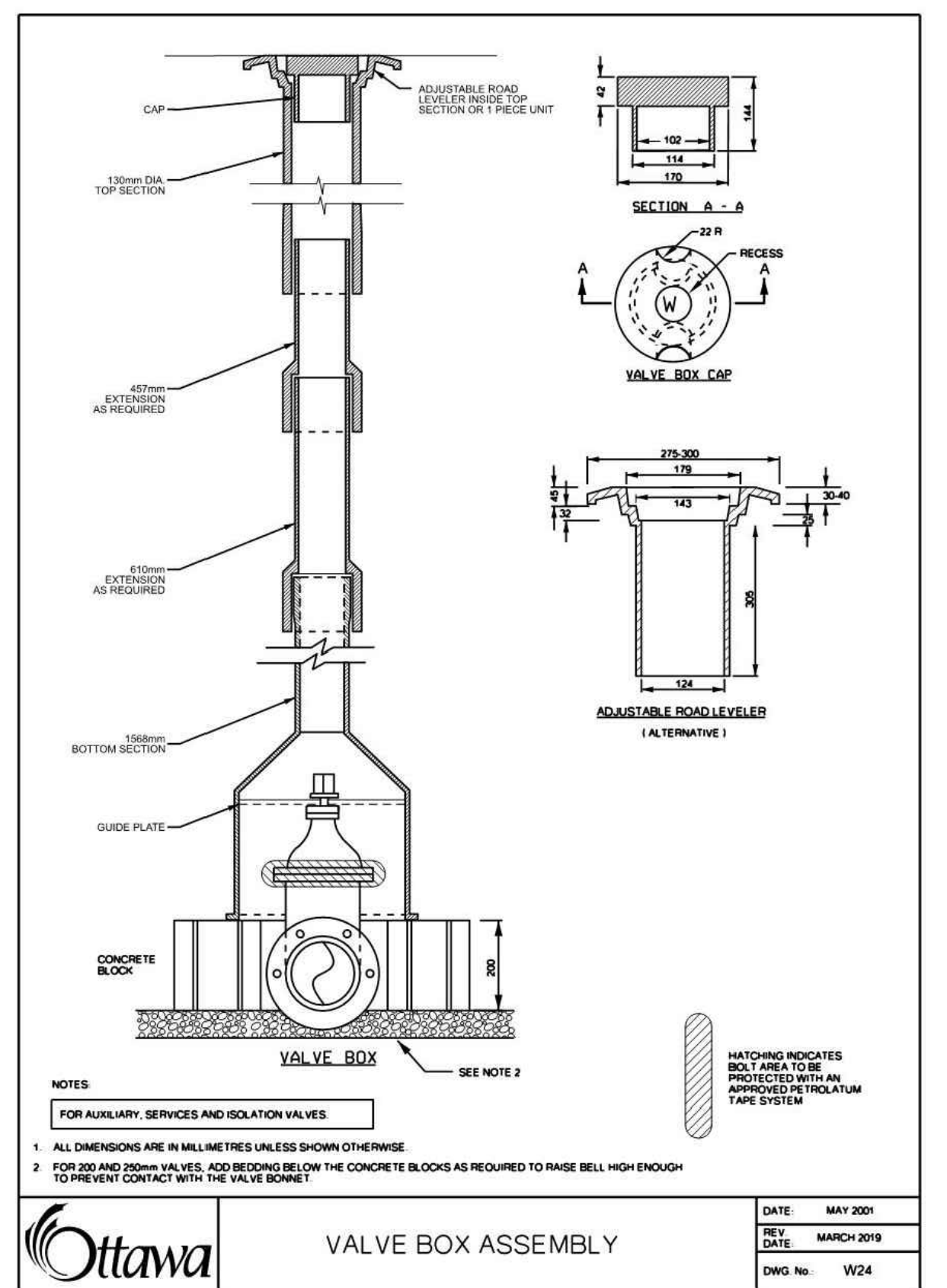
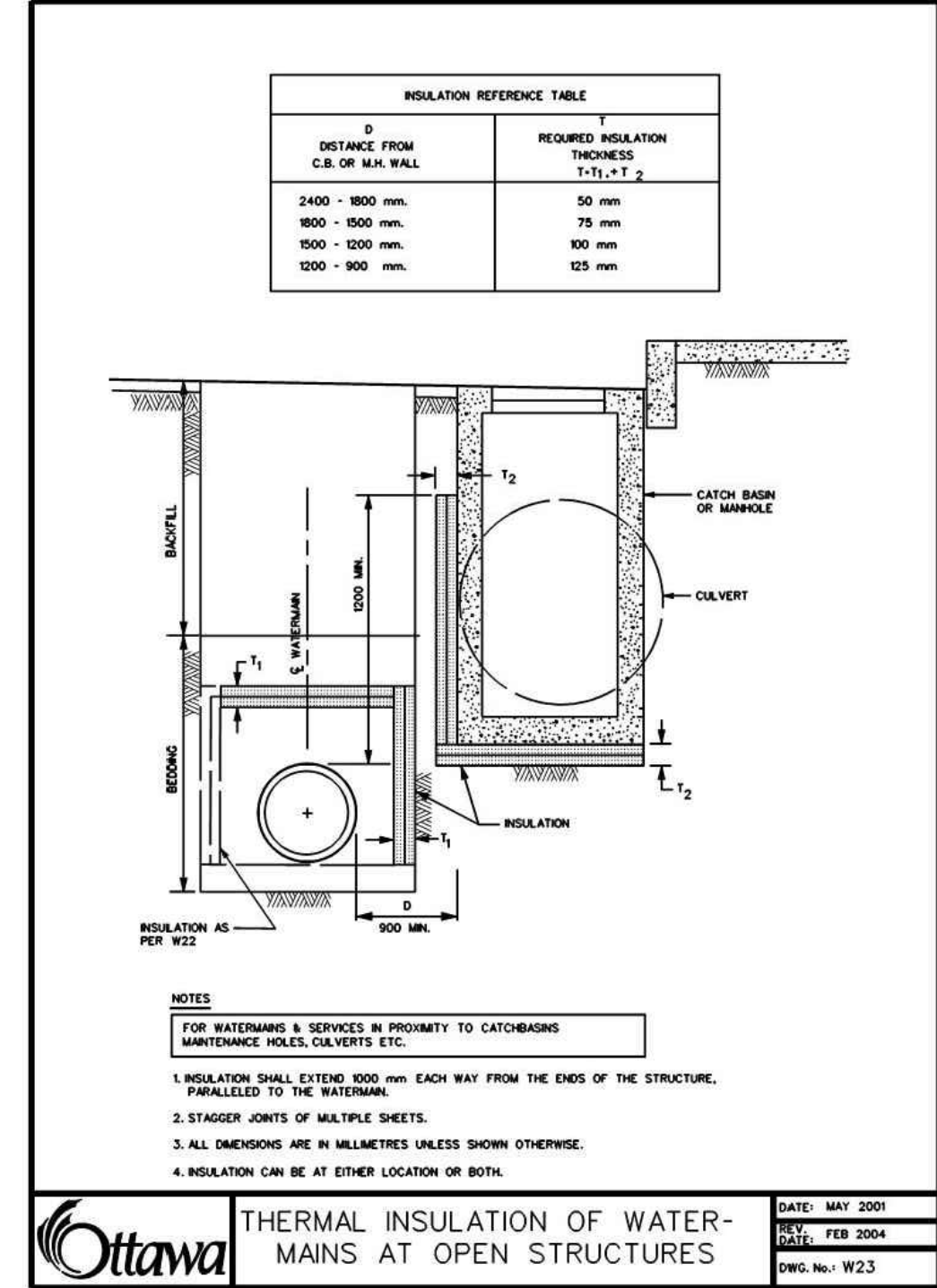
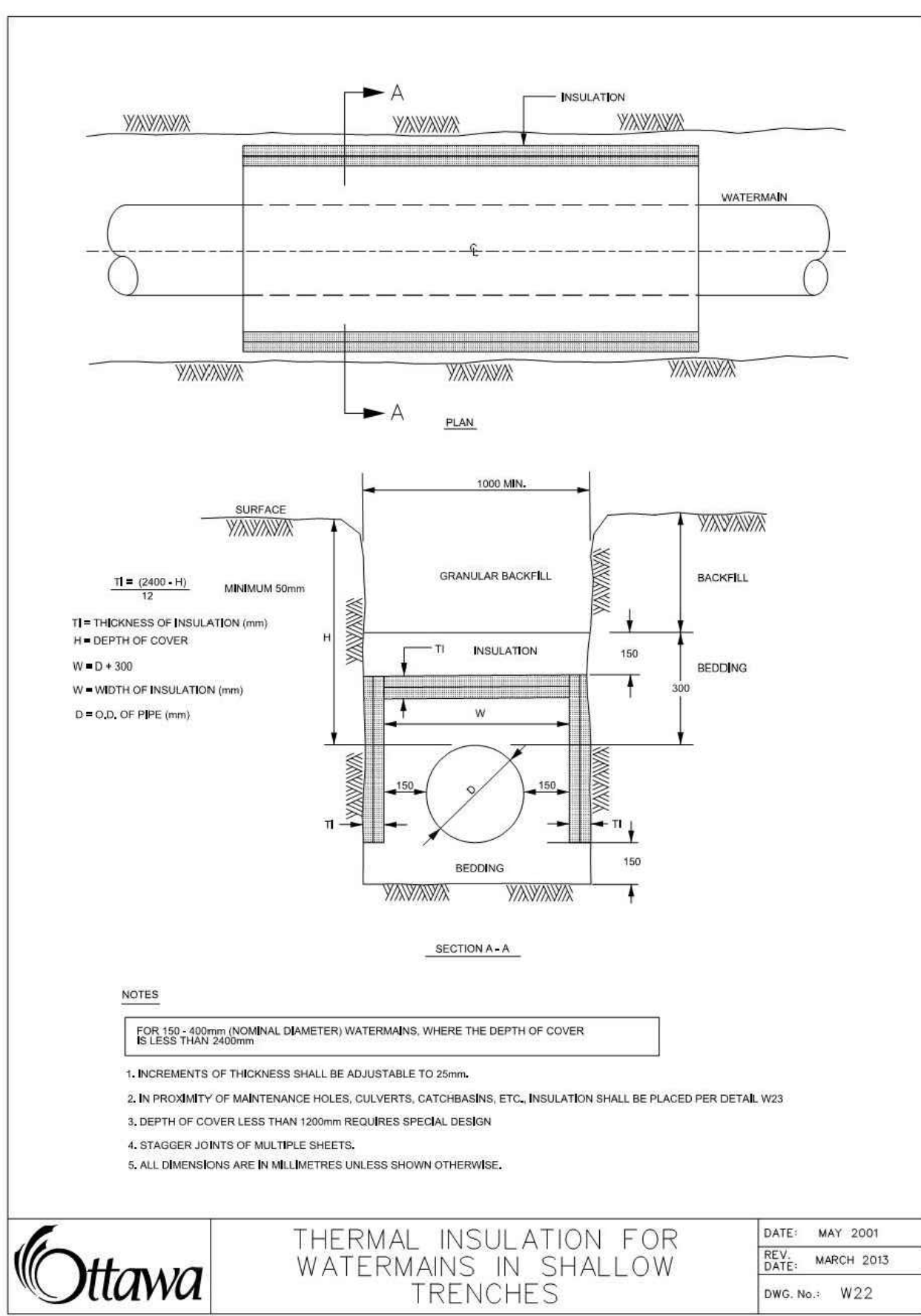
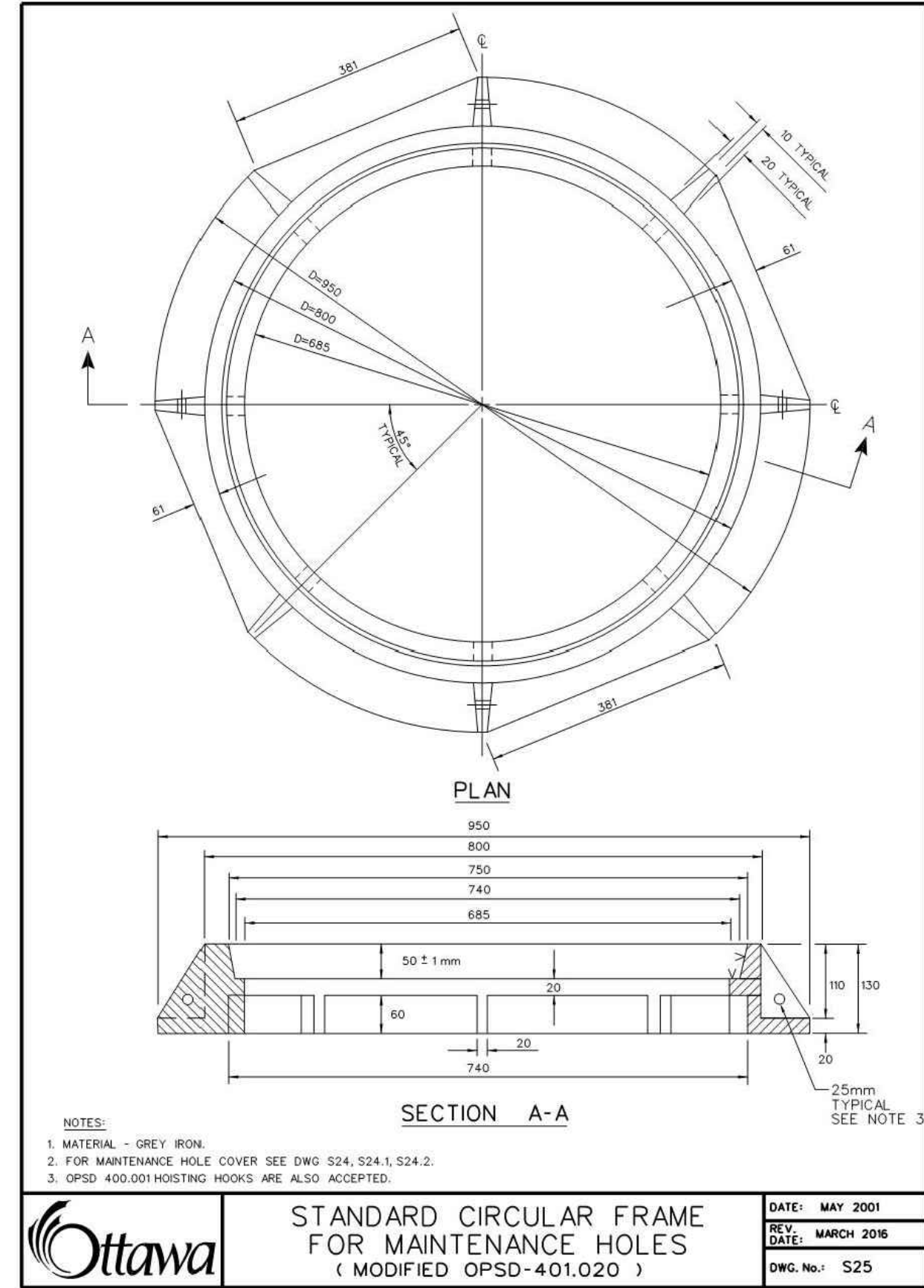
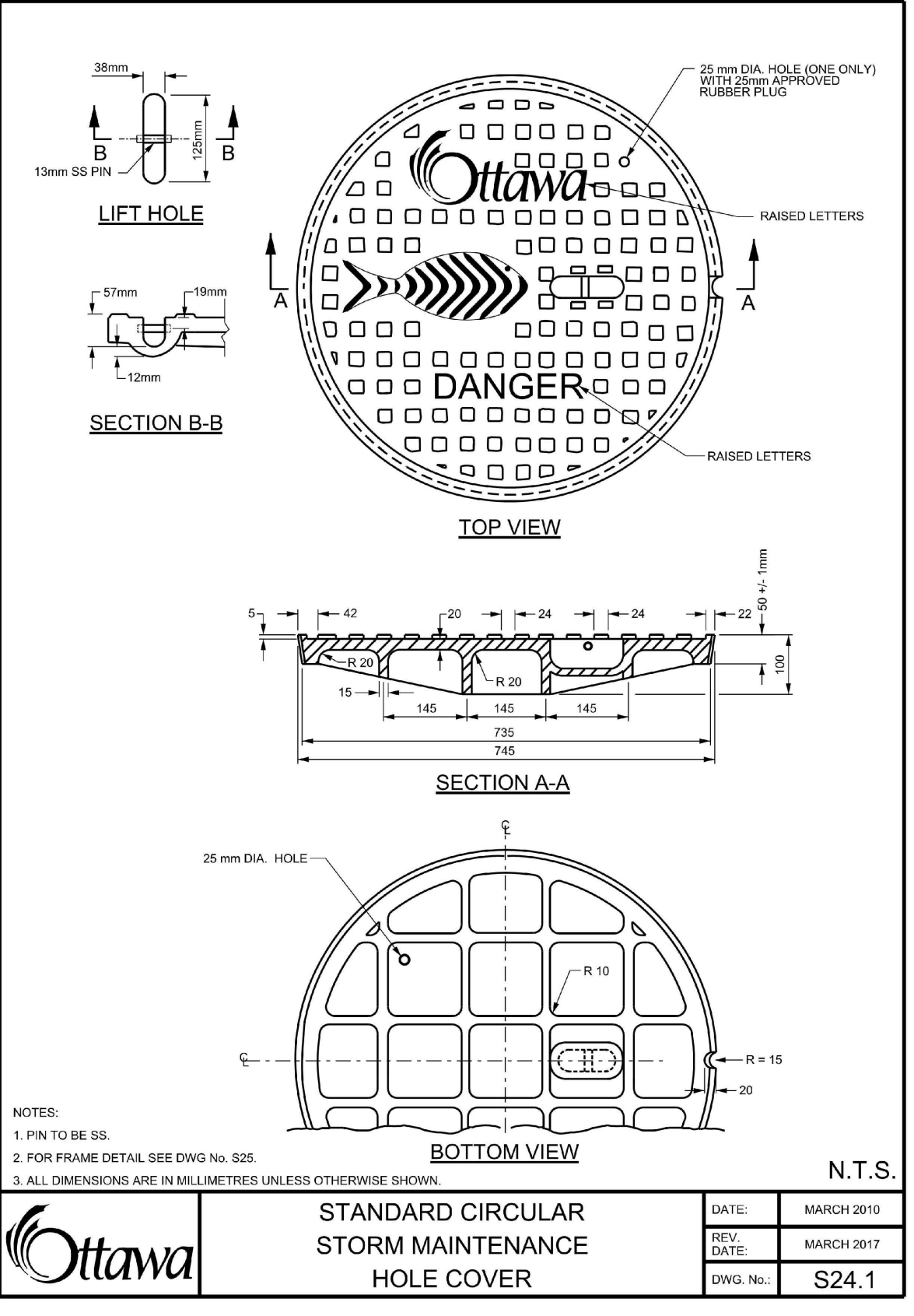
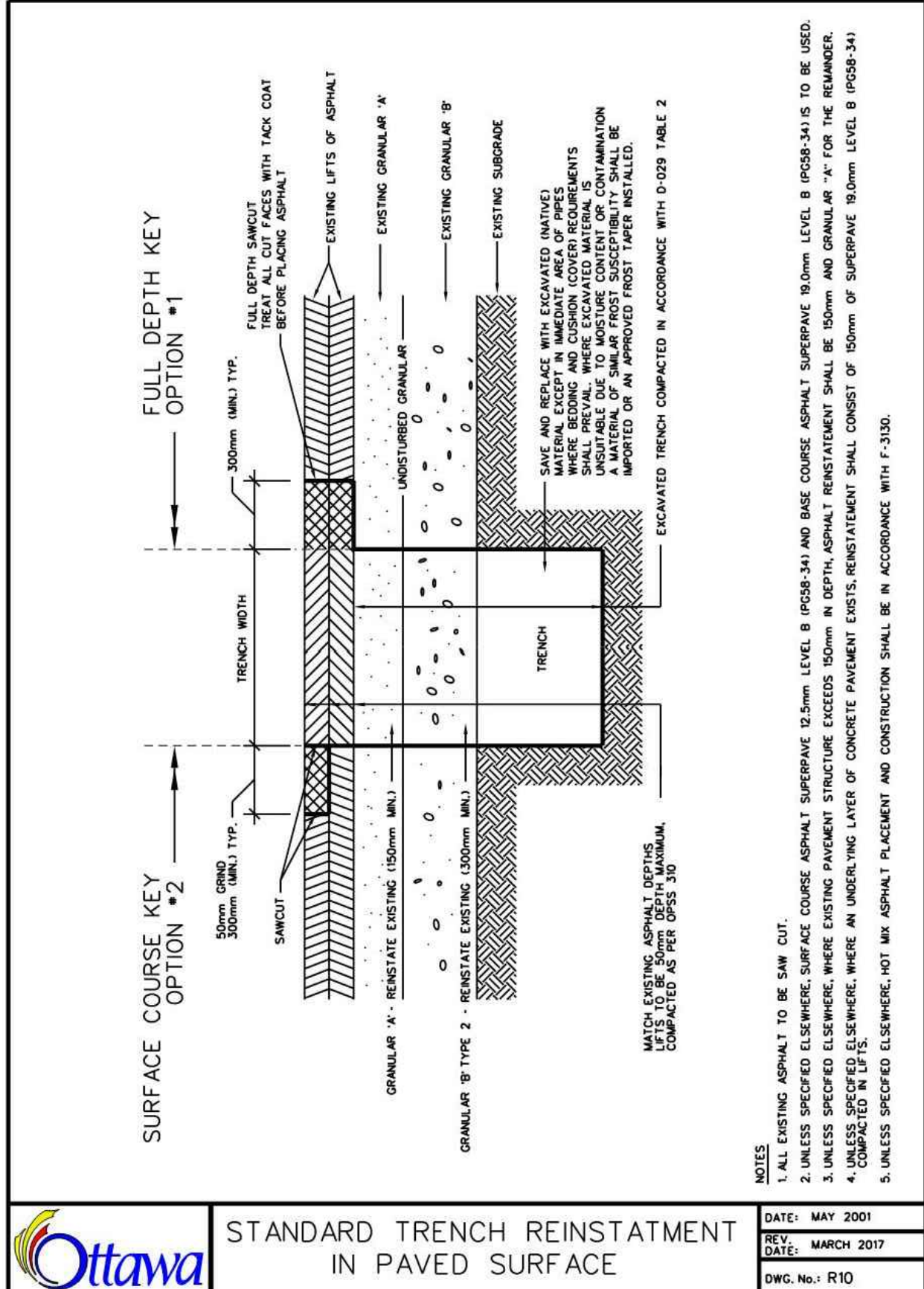
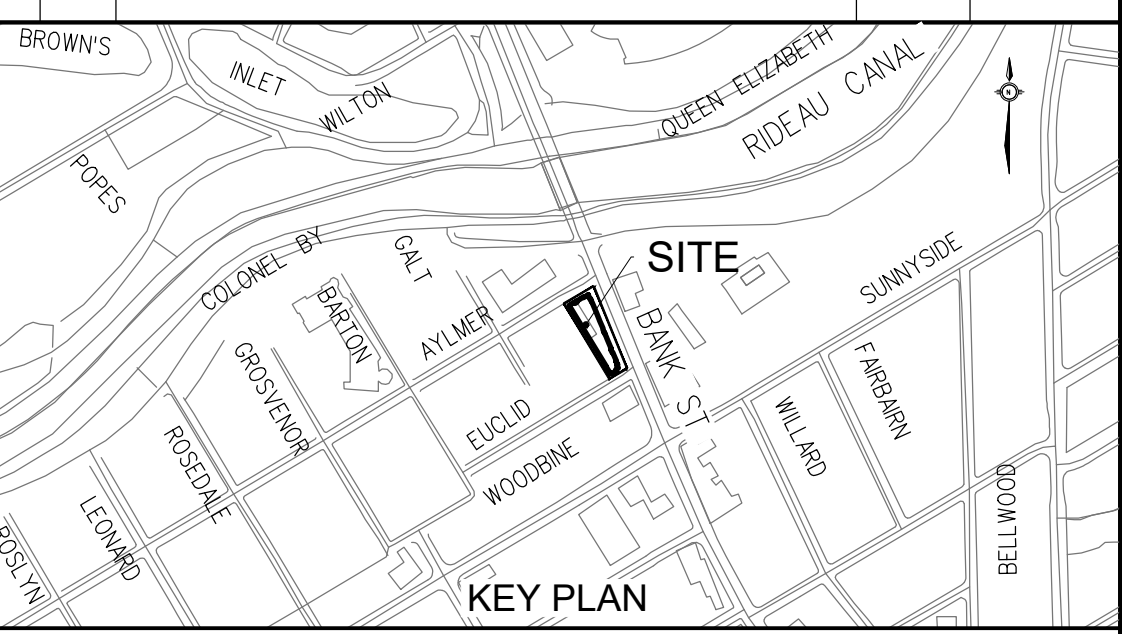

PROPOSED MIXED-USE RETAIL & RENTAL APARTMENT BUILDING
1050&1060 BANK STREET
OTTAWA, ON

Contract No. C101
Drawing No. C101
Sheet No. of 5
Asset No.
Asset Group

TYPICAL DETAILS

Des: DG Chk'd: JF
Dwn: NI Chk'd: JF
Utility Circulation No.: CTY
Construction Inspector:
Scale:

NOTE:
The location of utilities is approximate only, the exact location should be determined by consulting the municipal authorities and utility companies concerned. The contractor shall prove the location of utilities and shall be responsible for adequate protection from damage.

MORRISON HERSHFIELD
200-2932 BASELINE RD.
OTTAWA, ON K2H 1B1

No.	Description	By	Date (dd/mm/yy)
0	ISSUED FOR SITE PLAN APPROVAL	J.F.	02/12/19
1	RE-ISSUED FOR SITE PLAN APPROVAL	J.F.	18/06/20

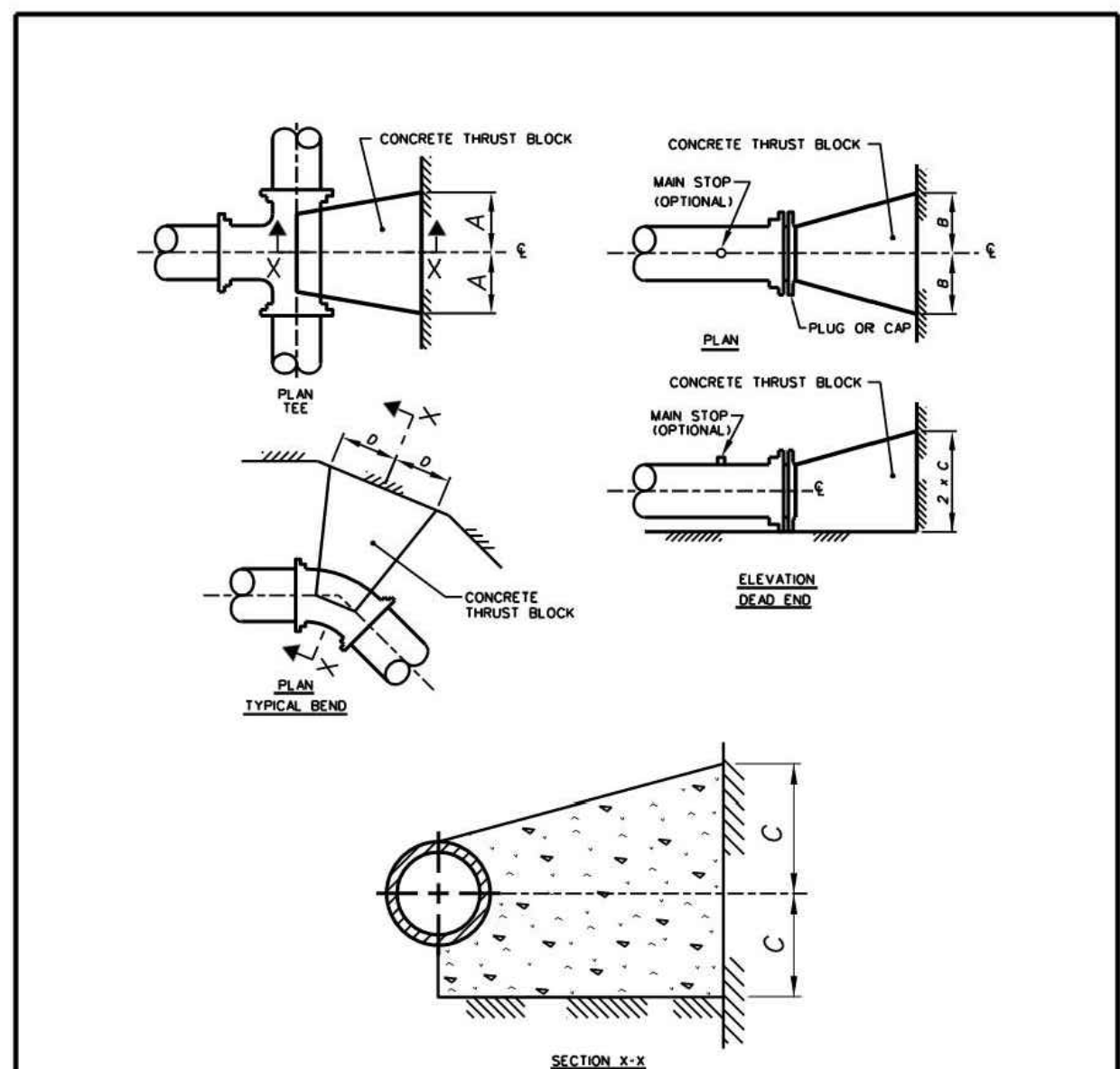
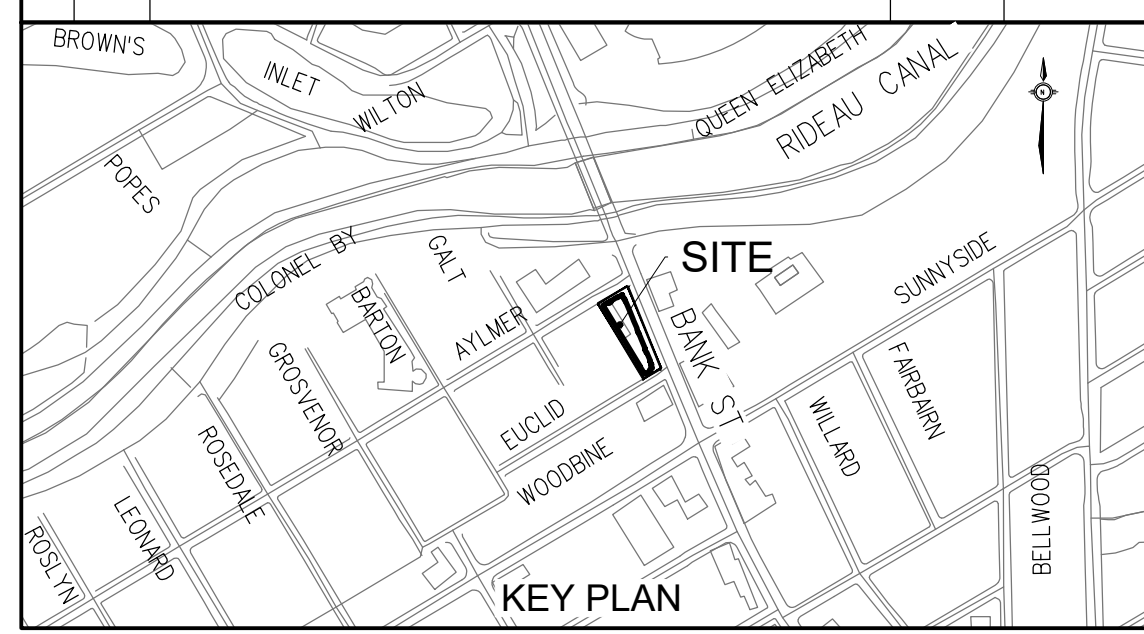

- NOTES:
1. CONCRETE SHALL BE PLACED TO WITHIN 50mm OF FACE OF THE BELL.
 2. BOND BREAKER TO BE USED BETWEEN CONCRETE AND FITTINGS.
 3. ALL DIMENSIONS ARE IN MILLIMETERS UNLESS OTHERWISE SHOWN.
 4. REFER TO W25.4 FOR ADDITIONAL REQUIREMENTS.
 5. THRUST BLOCKS SHALL BE 20 MPa CONCRETE AND AS SHOWN ON ABOVE DRAWINGS UNLESS OTHERWISE DIRECTED BY THE CONTRACT ADMINISTRATOR. THE BLOCK SHALL BE CENTERED ON THE THRUST FORCE AND SHALL ALSO PARTIALLY CRADLE THE FITTING TO DISTRIBUTE THE FORCE. THE SIDES OF THE BLOCK SHALL BE 80mm FROM THE JOINT ON EITHER SIDE OF THE BEND OR TEE.
 6. THE CONCRETE WHERE POSSIBLE SHALL BE PLACED AGAINST UNDISTURBED SOIL AT THE BOTTOM AND SIDE OF THE TRENCH WHERE IT IS NOT POSSIBLE, THE FILL BETWEEN THE BEARING SURFACE AND THE UNDISTURBED SOIL MUST BE COMPACTED IN ACCORDANCE WITH D-025.
 7. EXCEPT FOR THE ADDITION OF WATER, CONCRETE FOR THRUST BLOCKS SHALL COME PREPARED FROM CONCRETE SUPPLIER, AS 'READY MIX' FROM A CONCRETE TRUCK ON-SITE MIXING OF CEMENT, SAND AND AGGREGATE ETC. BY THE CONTRACTOR, FOR THE PURPOSE OF MAKING CONCRETE THRUST BLOCKS/ANCHORS WILL NOT BE ACCEPTED.

Ottawa
CONCRETE THRUST BLOCKS FOR PVC AND DI PIPE 400mm AND UNDER
DATE: MAY 2001
REV. DATE: MARCH 2016
DWG. No.: W25.3

1. SOIL DESCRIPTION: VERY FINE SANDS, SANDY CLAYS, CLAYS
SOILS WITH TYPICAL BEARING STRENGTH OF 100 TO 199 KPa

PIPE DIAMETER	DIMENSION NOTED ON W25.3			
	A	B	C	D
102	250	250	200	200
152	400	400	250	300
203	550	550	300	450
254	650	650	400	500
305	800	800	450	650
406	1050	1050	600	850

2. SOIL DESCRIPTION: SILTY SAND GRAVELS OR CLAYEY SAND GRAVEL MIXTURES, MODERATE AMOUNT OF FINES
SOILS WITH TYPICAL BEARING STRENGTH OF 200 TO 299 KPa

PIPE DIAMETER	DIMENSION NOTED ON W25.3			
	A	B	C	D
102	200	200	150	150
152	250	250	200	200
203	350	350	250	270
254	450	450	300	350
305	500	500	350	400
406	750	750	400	600

3. SOIL DESCRIPTION: SANDS, GRAVELS AND GRAVEL-SAND MIXTURES, LITTLE OR NO FINES
SOILS WITH TYPICAL BEARING STRENGTH OF 300 KPa AND OVER

PIPE DIAMETER	DIMENSION NOTED ON W25.3			
	A	B	C	D
102	150	150	150	150
152	200	200	200	200
203	300	300	200	230
254	400	400	250	270
305	450	450	300	300
406	650	650	350	450

- NOTES:
1. THE ABOVE THRUST BLOCK DIMENSIONS MEET OR EXCEED THE WATERMAIN DESIGN CRITERIA FOR FUTURE ALTERATIONS AUTHORIZED UNDER A DRINKING WATER WORKS PERMIT.
 2. THE ASSUMPTIONS MADE FOR THE ABOVE CALCULATIONS ARE AS FOLLOWS:
 - a) MAXIMUM OPERATING PRESSURE OF 100 psi.
 - b) MAXIMUM SURGE PRESSURE WITH A FLOW VELOCITY CHANGE OF 5.0 m/s OF 119 psi (8.3 bar) FOR CLASS 12 DI AND FOR PVC MAX. SURGE IS 38 psi.
 3. THE TABLES APPLY TO BOTH DUCTILE IRON AND PVC, WHERE ONE LENGTH EXCEEDED THE OTHER THE LONGER LENGTH WAS USED.
 4. DIMENSIONS MAY BE ADJUSTED SO LONG AS THE BEARING SURFACE AREA OF THE THRUST BLOCK IS NOT REDUCED.
 5. TO BE USED IN CONJUNCTION WITH W25.1.

Ottawa
THRUST BLOCK DIMENSION TABLES FOR PVC AND DI PIPE 400mm AND UNDER
DATE: MAY 2001
REV. DATE: MARCH 2011
DWG. No.: W25.4

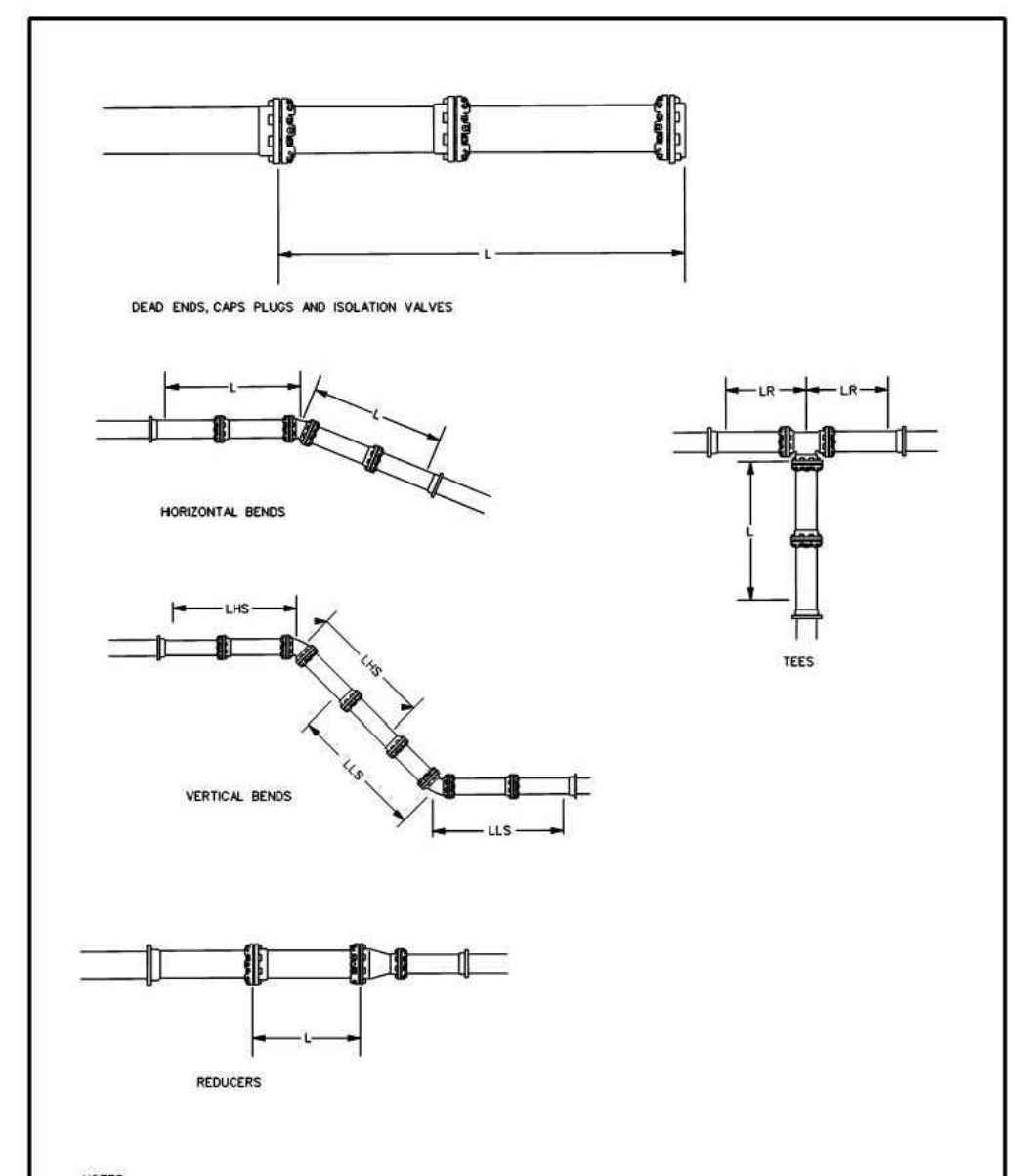

- NOTES:
1. ANY JOINT THAT FALLS WITHIN THE RECOMMENDED LENGTH (L) SHALL BE RESTRAINED. SEE DRAWING W25.6.
 2. TO REDUCE THE NUMBER OF RESTRAINERS REQUIRED THE USE OF FULL PIPE LENGTHS IS RECOMMENDED IN THESE AREAS.

Ottawa
RESTRAINING AND RETAINING RINGS FOR PVC AND DI PIPE 400mm AND UNDER
DATE: MAY 2001
REV. DATE: NONE
DWG. No.: W25.5

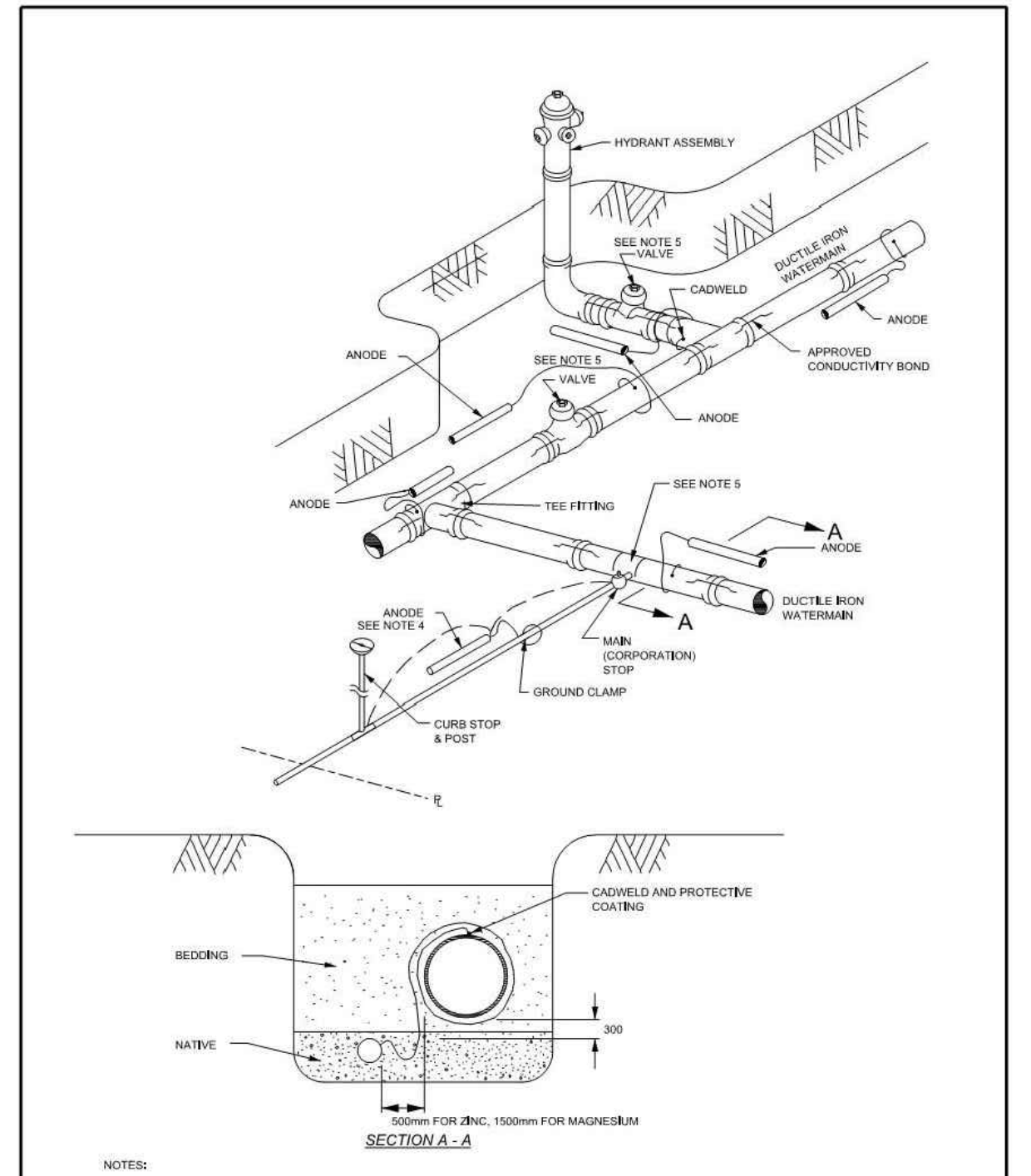

- NOTES:
1. ANODE CONNECTING WIRE TO BE LOOPED AROUND PIPES / FITTINGS AND KNOTTED.
 2. PROTECTIVE COATING TO BE APPLIED TO ALL CADWELDS.
 3. ANODE TYPE & SPACING AS PER W41.
 4. CONNECT ANODE TO COPPER SERVICE USING A GROUND CLAMP AND FOR PEX SERVICES CONNECT ANODE TO TRIGGER WIRE TERMINALS ON BOTH MAIN AND CURB STOPS.
 5. PROTECT AUXILIARY VALVES, ISOLATION VALVES, SADDLES AND MAIN STOPS WITH A PETROLIUM-BASED TAPE COATING SYSTEM. FOR PEX SERVICES ALSO WAX TAPE CURB STOP UP TO THE BASE OF THE TEE HEAD.
 6. ALL DIMENSIONS ARE IN MILLIMETERS.

Ottawa
CATHODIC PROTECTION FOR DUCTILE IRON WATERMAIN SYSTEMS
DATE: MAY 2001
REV. DATE: MARCH 2013
DWG. No.: W39

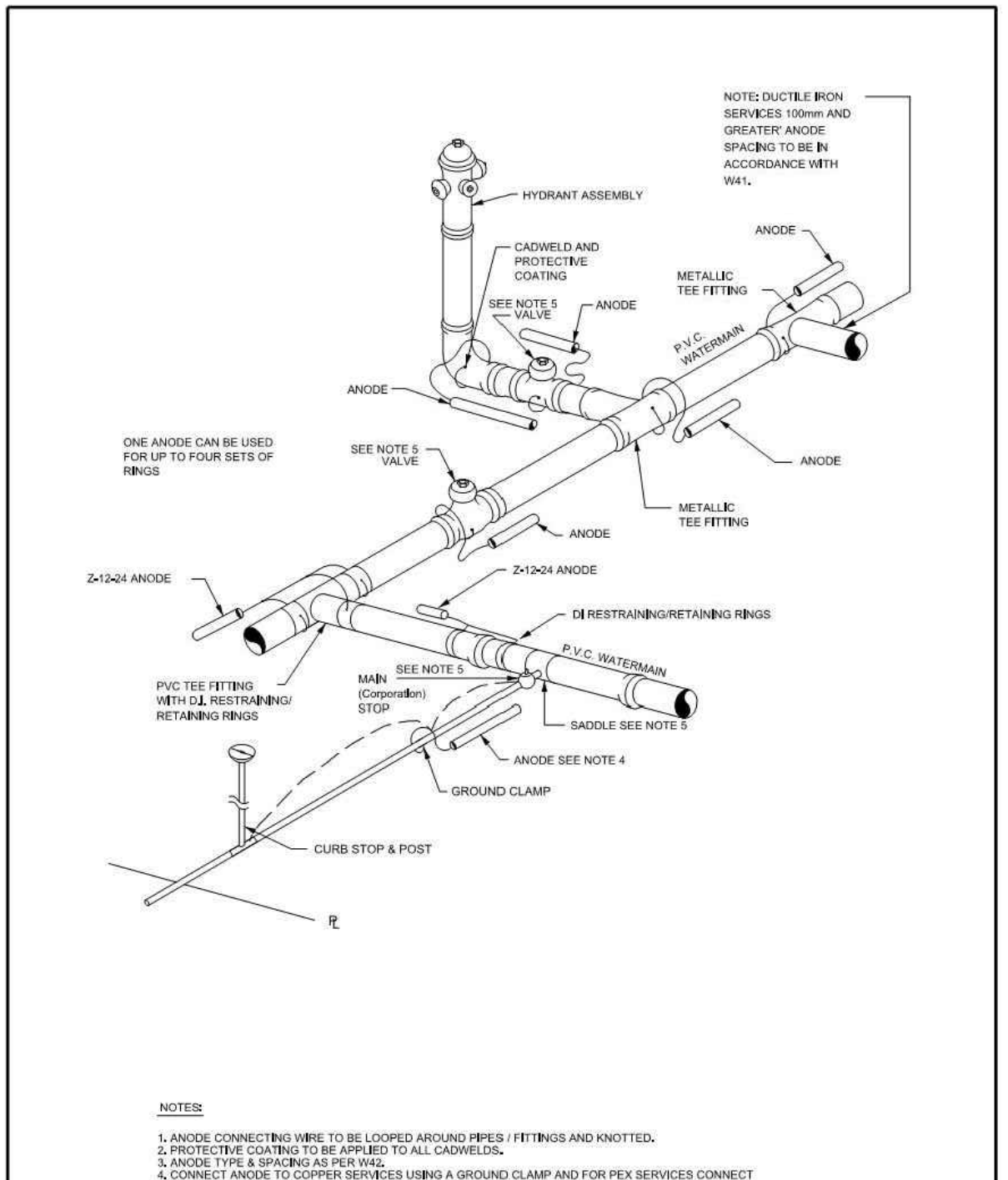

- NOTES:
1. ANODE CONNECTING WIRE TO BE LOOPED AROUND PIPES / FITTINGS AND KNOTTED.
 2. PROTECTIVE COATING TO BE APPLIED TO ALL CADWELDS.
 3. ANODE TYPE & SPACING AS PER W41.
 4. CONNECT ANODE TO COPPER SERVICE USING A GROUND CLAMP AND FOR PEX SERVICES CONNECT ANODE TO TRIGGER WIRE TERMINALS ON BOTH MAIN AND CURB STOPS.
 5. PROTECT AUXILIARY VALVES, ISOLATION VALVES, SADDLES AND MAIN STOPS WITH A PETROLIUM-BASED TAPE COATING SYSTEM. FOR PEX SERVICES ALSO WAX TAPE CURB STOP UP TO THE BASE OF THE TEE HEAD.
 6. ALL DIMENSIONS ARE IN MILLIMETERS.

Ottawa
CATHODIC PROTECTION FOR PVC WATERMAIN SYSTEMS
DATE: MAY 2001
REV. DATE: MARCH 2013
DWG. No.: W40

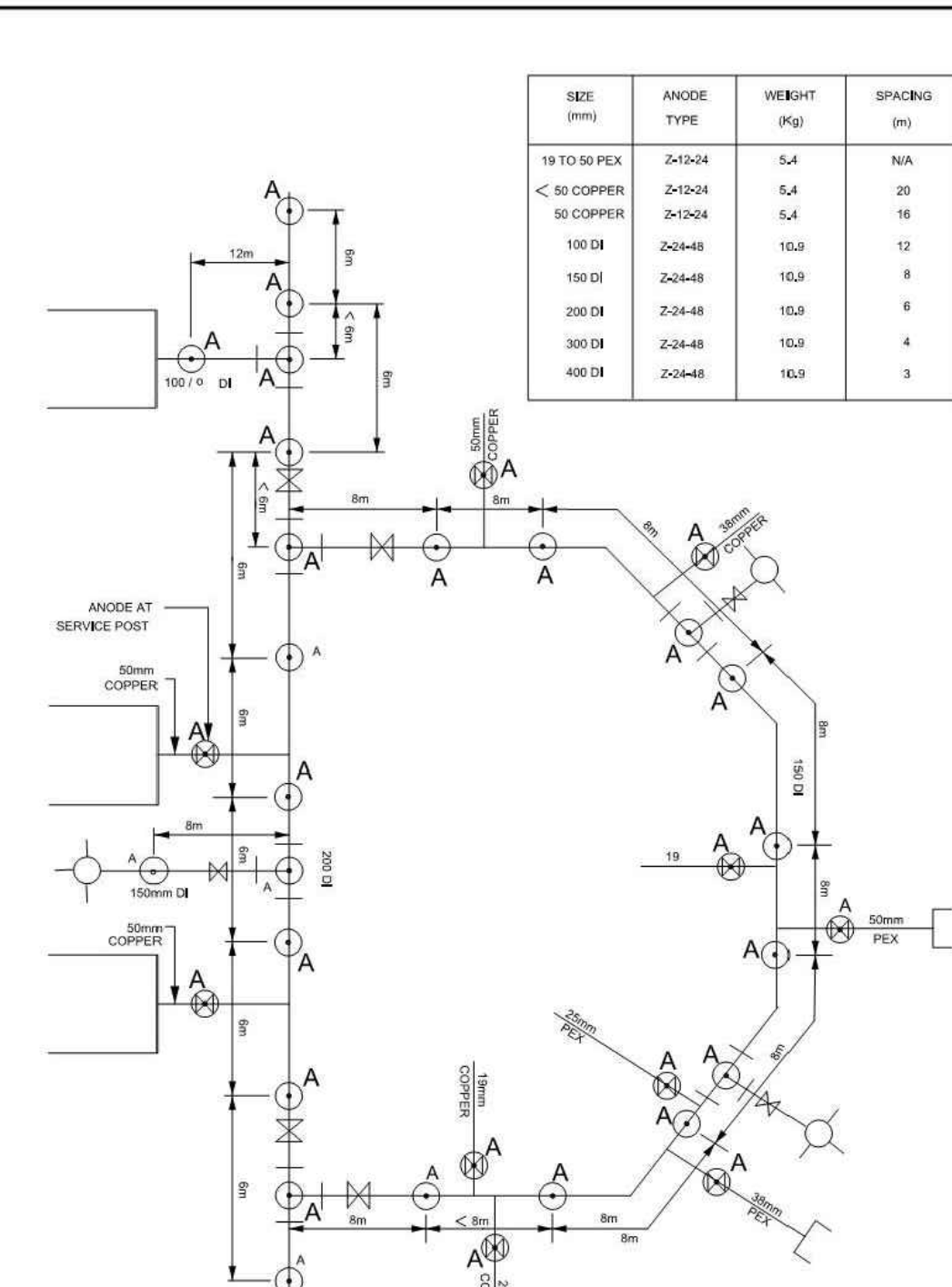

- NOTES:
1. ALL DIMENSIONS ARE IN MILLIMETERS UNLESS OTHERWISE SHOWN.

Ottawa
TYPICAL ANODE INSTALLATION D.I. WATERMAIN
DATE: MAY 2001
REV. DATE: MARCH 2013
DWG. No.: W41

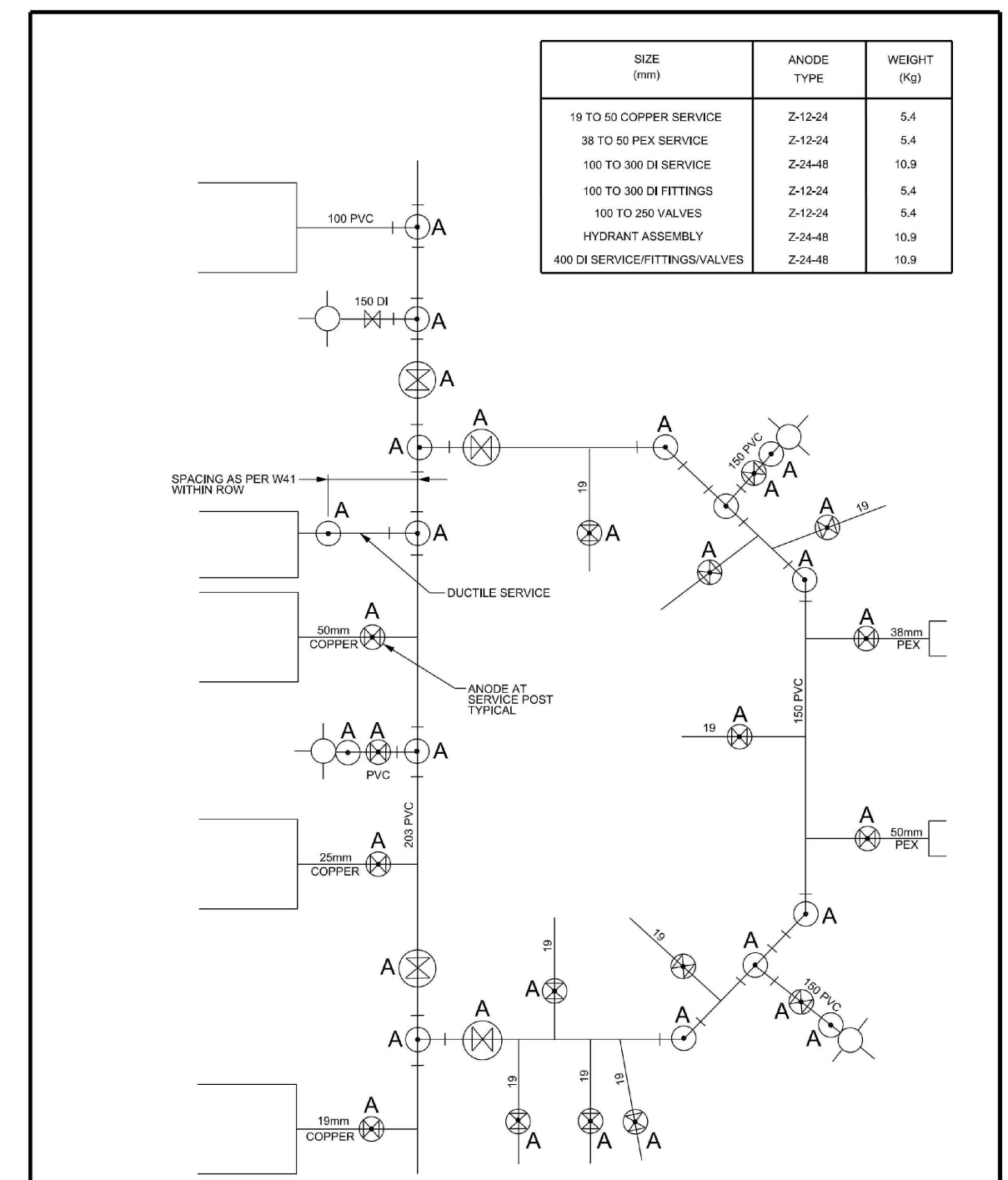

- NOTES:
1. ALL DIMENSIONS ARE IN MILLIMETERS UNLESS SHOWN OTHERWISE.

Ottawa
TYPICAL ANODE INSTALLATION PVC WATERMAIN
DATE: MAY 2001
REV. DATE: MARCH 2014
DWG. No.: W42

O:\Ottawa\proj\2170710\Civil\10 Design\Drawings\07 Sheets\Details\S1.jpg

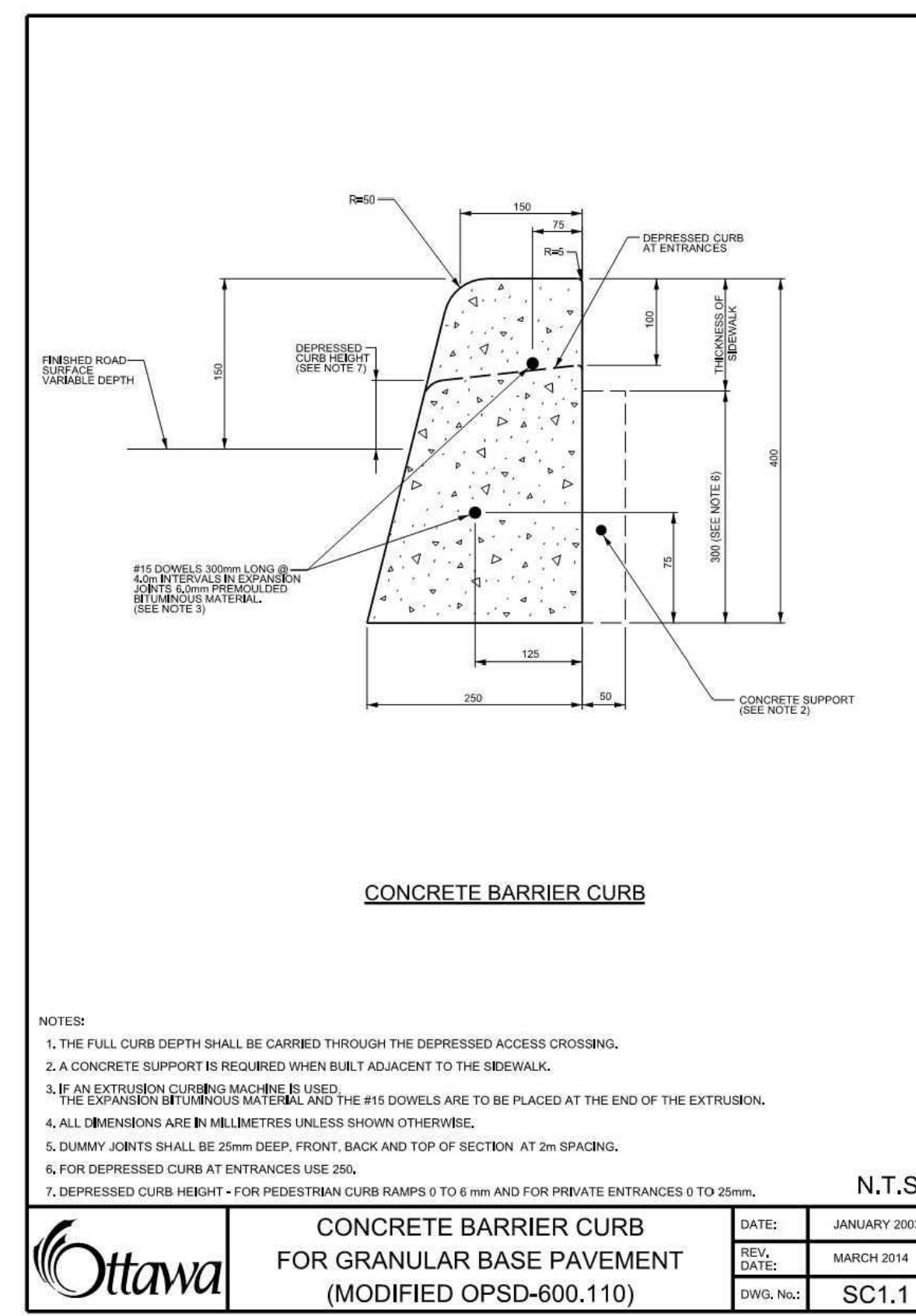
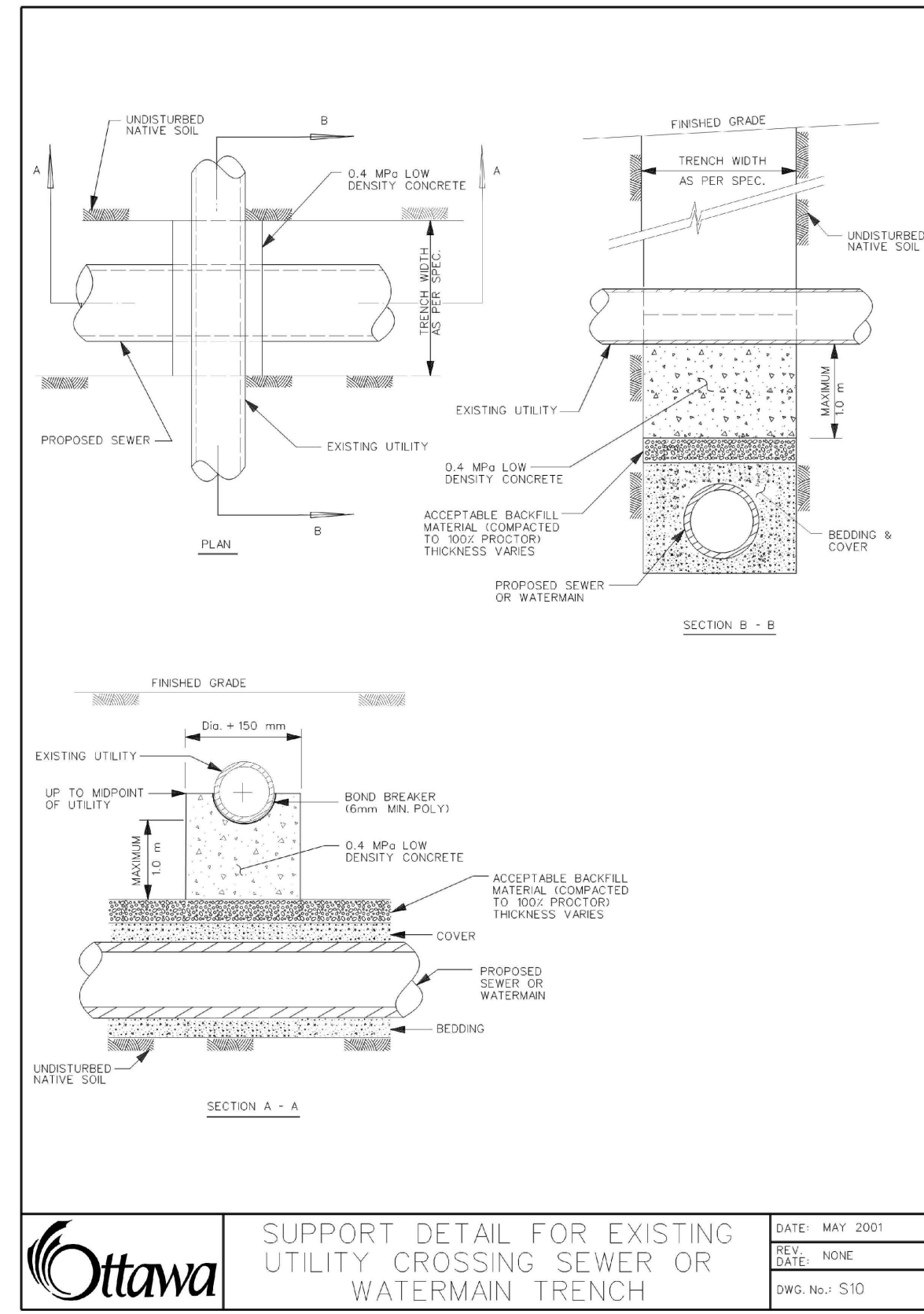

PROPOSED MIXED-USE RETAIL & RENTAL APARTMENT BUILDING
1050&1060 BANK STREET OTTAWA, ON

TYPICAL DETAILS

Contract No.	Drawing No. C102
Sheet No.	of 5
Asset No.	
Asset Group	
Des: DG	Chk'd: JF
Dwn: NI	Chk'd: JF
Utility Circulation No.:	CTY---
Construction Inspector:	
Scale:	

NOTE:
The location of utilities is approximate only, the exact location should be determined by consulting the municipal authorities and utility companies concerned. The contractor shall prove the location of utilities and shall be responsible for adequate protection from damage.

MORRISON HERSHFIELD
200-2932 BASELINE RD.
OTTAWA, ON K2H 1B1

No.	Description	By	Date (dd/mm/yy)
0	ISSUED FOR SITE PLAN APPROVAL	J.F.	02/12/19
1	RE-ISSUED FOR SITE PLAN APPROVAL	J.F.	18/06/20

