



MORRISON HERSHFIELD

Site Servicing and Stormwater Management Design Brief

1050&1060 Bank Street, Mixed-Use Development

Ottawa, Ontario

Presented to:

Dominic Santaguida
2641723 Ontario Inc.

Shawn Wessel
Project Manager - Infrastructure Approvals at City of
Ottawa

Project: 190500700
Revision #1

December 15, 2020

P:\2019\190500700-1050-1060 BANK STREET-CIVIL\08.
WORKING\MUNICIPAL\BANK&AYLMER CIVIL DESIGN BRIEF_2020-09-24.DOCX

TABLE OF CONTENTS

	Page	
1	INTRODUCTION	3
1.1	Site Description and Proposed Development	3
1.2	Background Documents	3
1.3	Consultation and Permits	4
1.4	Available Existing Infrastructure	4
2	GEOTECHNICAL STUDY	5
3	WATER SERVICES	5
3.1	Design Criteria	5
3.2	Adequacy of Supply for Domestic and Fire Flows	6
3.3	Check of High Pressures	7
3.4	Reliability Requirements	7
3.5	Summary and Conclusions	7
4	SANITARY SERVICING	7
4.1	Background and Existing Infrastructure	7
4.2	Review of Ground Water and Soil Conditions	7
4.3	Proposed Servicing and Calculations	7
4.4	Summary and Conclusions	8
5	STORM SERVICING AND STORMWATER MANAGEMENT	8
5.1	Background	8
5.2	Storm Servicing Strategy including Analysis of Existing Infrastructure	8
5.3	Proposed Storm Servicing	8
5.4	Grading	13
5.5	Erosion and Sediment Control	13
6	CONCLUSIONS	14
7	APPENDICES	15
Appendix A	Site Servicing, Grading and Erosion and Sediment Control, Catchments Plans and Details	
Appendix B	Correspondence with Regulatory Authorities	
Appendix C	Water Demand and FUS Calculations	
Appendix D	Sanitary Flow Calculations	
Appendix E	Storm Sewer Design Calculations	

TABLE OF CONTENTS (Continued)

Page

Appendix F	Site Servicing Checklist
Appendix G	Topographic and Legal Survey

1 Introduction

1.1 Site Description and Proposed Development

This report describes the site servicing and stormwater management design and calculations pertaining to a 6 storey mixed-use development proposed at 1050&1050 Bank Street. The existing site houses a parking lot and single-storey commercial/retail buildings.

Proposed grading and servicing is shown on the drawings included in **Appendix A**.

The format of this report matches that of the development servicing study checklist found in Section 4 of the City of Ottawa’s Servicing Study Guidelines for Development Applications. A completed copy of the checklist is provided in **Appendix F**.

1.1.1 Statement of Objectives and Servicing Criteria

The objective of this Site Servicing and Stormwater Management Report is to demonstrate that the proposed design meets the servicing requirements for the proposed development, while adhering to the appropriate regulatory requirements.

1.1.2 Location Map and Plan

The location of the site is illustrated in **Figure 1**. A detailed site layout is provided within the drawings in **Appendix A**.

Figure 1- Key Plan



The site is currently zoned TM2 H (15) – Traditional Main Street zone.

A portion of the existing land is currently used as commercial/retail stores, while the remainder used as parking lot/storage area.

1.2 Background Documents

Existing conditions are shown on the Topographic and Legal Survey (**Appendix G**).

1.3 Consultation and Permits

1.3.1 Pre-consultation Meetings

A pre-consultation meeting was held with representatives of the City of Ottawa and the consultant design team on October 18th, 2018. The resulting comments that would affect this report are as follows:

- Excavation: Please note that a pre and post construction CCTV scan and report is required prior to approvals and if blasting is proposed - Constructability and Vibration Reports are required, including monitoring devices on all public infrastructure located within the ROW. Assess the condition of the existing storm and sanitary sewer via CCTV to determine that the existing sewer are in good condition and thereby viable candidates for drainage of the proposed addition.
- Control post-development flow from the site to the 1:5 year predevelopment level for all storm events up to and including 1:100 year storm.
- Pre-development flow to be calculated using the smaller of a runoff coefficient of 0.5 or the actual existing runoff coefficient. Use either a T_c of 20 minutes or calculated the pre-development T_c but not less than 10 minutes
- Maximum ponding on the public and private roadways and parking lot surfaces during 1:100 year storm event = 350mm max.
- Consult with the RVCA regarding storm water quality/restrictions
- Determine the total water demand based on maximum demand and required fire flow for water boundary conditions.

The full comments regarding site-servicing and stormwater management-specific requirements can be found in **Appendix B**.

1.3.2 Adherence to Zoning and Related Requirements

The property is zoned as a Traditional Main Street.

1.4 Available Existing Infrastructure

Sewer and watermain mapping collected from the City of Ottawa indicate that the following services exist across the property frontages within the adjacent municipal rights-of-way.

Aylmer Street

- 203mm diameter UCI watermain
- 300 mm diameter PVC sanitary sewer main discharging into Bank St
- 300 mm diameter PVC storm sewer

Bank Street

- 305mm diameter PVC watermain
- 300mm diameter PVC sanitary sewer discharging to the Rideau River interceptor
- 375mm diameter Conc. storm sewer

Euclid Street

- 152mm diameter UCI watermain
- 300 mm diameter PVC sanitary sewer discharging into Bank St. 1200 mm diameter Brick Collector south of Grove Ave
- 300 mm diameter Conc. storm sewer



2 Geotechnical Study

A Geotechnical Investigation was undertaken by Paterson Group and is documented in Report No. PG4506-1 (Revision 1) dated April 8, 2020.

A total of 10 boreholes were drilled to a maximum depth of 15.2 m below the existing ground surface. No evidence of bedrock was encountered, except in BH 3 which was terminated on practical refusal to augering at a depth of approximately 13.7 m. The subsurface profile at the borehole locations consists of a pavement structure underlain by a fill layer to approximately 0.4 to 2.6 m depth. The fill was generally observed to consist of a loose, brown sand with some silt, gravel, and asphalt. The fill was underlain by deposits of compact to very dense sand and very dense silty sand to sandy silt.

Based on available geological mapping, the subject site is located in an area where the bedrock consists of interbedded limestone and shale of the Verulam formation.

Groundwater was encountered at depths of 11-13 m below the existing ground surface.

The geotechnical report provides recommendations for excavation, backfill, pavement structure and pipe bedding and backfill.

3 Water Services

3.1 Design Criteria

The water service will be designed in accordance with the 2010 City of Ottawa Water Design Guidelines as well as MOE Design Guidelines for Drinking Water Systems. The proposed development lies within the City of Ottawa 1W pressure zone as shown by the Pressure Zone map in **Appendix C**

The required domestic water demand and pressure design parameters for the development has been calculated based in **Table 1**:

Table 1– Summary of Water Demand Parameters

Design Parameter	Value	
	Residential	Retail
Average Daily Demand	350 L/d/P ¹	2500 L/(1000m ² /d)
Max. Daily Peaking Factor	7.4 x Average Daily ²	1.5 x Average Daily ³
Max. Hourly Peaking Factor	11.2 x Average Daily ²	1.8 x Max Daily ³
Minimum Watermain Size	150mm diameter	
Minimum Depth of Cover	2.4m from top of watermain to finished grade	
Min. pressure during normal operating conditions	345kPa	
Max. pressure during normal operating conditions	552kPa	
Min. pressure during maximum hourly demand	276kPa	
Min. pressure during maximum daily demand + fire flow	140kPa	

¹ Daily average based on Appendix 4-A from Water Supply Guidelines

² Residential Max. Daily and Max. Hourly peaking factors per MOE Guidelines for Drinking-Water Systems Table 3-3 for 0 to 500 persons

³ Retail/Commercial Max. Daily and Max. Hourly peaking factors per from Water Supply Guidelines, Table 4.2 – Shopping Center

Table 2 summarizes the water demand/fire flow for the development based on the **Ottawa Design Guidelines (2010 incl. Technical Bulletins)** and the **Fire Underwriters Survey (1999)**:

Table 2– Summary of Water Demand Calculations

Design Parameter	Water Demand (L/s)	
	Residential	Retail
Average Daily Demand	0.34	0.024
Maximum Daily Demand	2.53	0.036
Maximum Hourly Demand	3.81	0.065
Fire Flow	183.33	
Total Max Daily Demand + Fire Flow	185.90	
Max Hourly Demand	3.87	

Domestic and fire flow calculations are provided in **Appendix C**. Supporting correspondence from the Architect is provided in **Appendix C**.

3.2 Adequacy of Supply for Domestic and Fire Flows

Preliminary water demands and fire flow requirements for the proposed development were provided to the City of Ottawa. These values were used to generate municipal watermain network boundary conditions, summarized in Table 3 and provided in full in Appendix C.

Table 3 – Summary of Boundary Conditions

Boundary Condition	Hydraulic Gradeline (HGL, m)
Minimum HGL	104.3
Maximum HGL	114.7
Max Day + Fire Flow	104.0

A 200 mm diameter water service is proposed. **Table 4** summarizes the residual pressure at the service entry, and demonstrates that the minimum pressures described in **Table 1** are achieved under the required conditions:

Table 4 – Summary of Residual Pressures

	Scenario		Source of Data
	Max Day + Fire	Max Hourly	
Residual Pressure at Service Entry including pipe losses (kPa)	289.2	321.1	Calculated (full calculations included in Appendix C)
Minimum Allowable Pressure (kPa)	140	276	City of Ottawa Water Design Guidelines

A domestic water booster pump will be required to meet the minimum required pressures at all floors more than 4.6m above the ground floor.

3.3 Check of High Pressures

The site is within Pressure Zone 1W, which operates at a maximum head of 115 m (City of Ottawa Water Master Plan, 2013, **Appendix C**). This would result in a maximum pressure above the finished floor elevation of approximately 426kPa, which falls under the maximum 552kPa defined in the guidelines.

3.4 Reliability Requirements

A shut off valve for the water service will be provided at the property line.

3.5 Summary and Conclusions

The proposed building will be serviced by a 200 mm diameter water service connected to the existing 305 mm diameter watermain in Bank Street.

4 Sanitary Servicing

4.1 Background and Existing Infrastructure

The sanitary service will be designed in accordance with the 2012 Ottawa City Sewer Design Guidelines. The surrounding municipal sanitary services are described in detail in **Section 1.4**. The site is serviced by separated storm and sanitary sewers.

4.2 Review of Ground Water and Soil Conditions

Recommendations regarding the installation of piped services that are provided in the geotechnical report will be incorporated into the contract specifications.

All proposed sewers will be installed above the groundwater table.

4.3 Proposed Servicing and Calculations

The proposed development will require a new 150mm diameter PVC sanitary service. The new 150mm diameter PVC sanitary service will extend from the east side of the building and connect to an existing 300mm diameter sanitary sewer in Bank Street. The sanitary servicing design parameters are defined in **Table 5**.

Table 5– Summarization of Sanitary Servicing Design Parameters

Design Parameter	Value
Residential Average Flow	280 l/c.d
Residential Peaking Factor	Based on the Harmon Equation $P.F. = 1 + \left(\frac{14}{4 + \left(\frac{P}{1000} \right)^{\frac{1}{2}}} \right) * K$
Commercial Average Flow	28,000 L/ha.d
Commercial Peaking Factor	1.5 if commercial contribution > 20%, else 1.0
Infiltration and Inflow Allowance	0.33 L/ha/s
Sanitary Sewer Sizing Based on the Manning's Equation	$Q = \frac{1}{n} \pi A R^{2/3} S^{1/2}$

Design Parameter	Value
Manning's Coefficient 'n'	0.013
Minimum Depth of Cover	2.5m from obvert of sewer to grade
Minimum Full Flowing Velocity	0.6m/s
Maximum Full Flowing Velocity	3.0m/s
As per Sections 4 and 6 of the City of Ottawa Sewer Design Guidelines, October 2012 incl. all Tech. Bulletins as of November 2019	

The proposed building will produce a sanitary flow of 1.11 L/s as determined in accordance with the City of Ottawa 2012 Sewer Design Guidelines. The proposed service lateral has a maximum capacity of 16.8 L/s. This is sufficient for the calculated sanitary flow.

Analysis of the catchment area shows that the estimated peak flow rate in the 300 mm sanitary sewer in Bank Street under existing conditions is 14.5 L/s. This will be increased by 1.11 L/s by the proposed development. The existing sewer has sufficient capacity accommodate this calculated flow. Full calculations can be found in **Appendix D**.

4.4 Summary and Conclusions

In conclusion the proposed development meets all required servicing constraints and associated design criteria/requirements.

5 Storm Servicing and Stormwater Management

5.1 Background

The majority of parking lot presently drains to two catch basins, which connect to the storm sewers draining the existing buildings. All storm water drained from this site is assumed to flow uncontrolled into STM 38050 in Bank Str. which travels via Sunnyside Ave. and Leonard Ave. where it then discharges into the Rideau River via a 1350mm storm sewer located on the southern boundary of Leonard Ave. (ID STM37913).

The City of Ottawa's Sewer Design Guidelines require more stringent control for the proposed development: the 100-year post-development storm flow is to be restricted to the 5-year pre-development run-off with an assumed pre-development coefficient no greater than 0.5.

For the proposed development, quantity control meeting the City of Ottawa requirements will be provided through the use of on-site detention and flow control devices.

5.2 Storm Servicing Strategy including Analysis of Existing Infrastructure

The proposed stormwater management system will provide the necessary detention storage on site to meet the stormwater management requirements. Quantity control will be provided at the source within each catchment to the extent possible.

The local pre-development drainage patterns will remain consistent post-development. As described in **Section 1.3.1**, all flows beyond the pre-development 5-year event will be controlled via local storage and controlled flow devices.

5.3 Proposed Storm Servicing

A new 250 mm diameter storm service will extend from the east side of the proposed development to connect to STM38050. In addition, the two existing catch basins (which currently drain the existing parking lot area) will be removed. The proposed pre-development and post-development catchment areas, runoff coefficients and catchment total areas are indicated in **Appendix E**.



5.3.1 Design Criteria (Minor and Major Systems)

For the design of stormwater management (SWM), the City of Ottawa's criteria for a Commercial/ Institutional/ Industrial development in an existing area will be applied (Section 8.3.7.3 of the City of Ottawa Sewer Design Guidelines). The key SWM requirements are:

- On-site SWM measures required to avoid impact on downstream system (i.e. existing storm sewers).
- Runoff to be controlled to the 5-year pre-development level as directed by the City.
- Pre-development flow to be calculated using the smaller of a runoff coefficient of 0.5 or the actual existing runoff coefficient. Use either a T_c of 20 minutes or calculated the pre-development T_c but not less than 10 minutes.
- All flow depths must be controlled on-site (i.e. no spill to adjacent properties or rights-of-way for flows up to the 100-year event).
- The design should consider the 100-year return period event, address performance for specified historical storms, and be stress tested for Climate Change using design storms calculated on the basis of a 20% increase of the City's IDF curves for rainfall events. Any instances of severe flooding identified through the stress test must be rectified.

Key drainage design requirements from the City of Ottawa Sewer Design Guidelines include:

- The minor system (underground storm sewers) is designed to capture the 2-year event (minimum). Inlet Control Devices should be utilized to minimize surcharging during the 100-year event.
- The minor system is designed to convey the 2-year event, with the hydraulic grade line (HGL) below the crown of the pipe (except where impacted by boundary conditions – in which case the HGL shall not exceed 0.3m below the underside of the footings during the 100-year event).
- For events greater than the 100 year return period, spillage is directed to a public ROW and not to neighbouring private property.
- The site grading ensures that the property being developed is higher than the spill elevation of the adjacent municipal ROW. This is considered especially critical if underground parking is being proposed. The grading ensures sufficient positive drainage away from the building, with a minimum slope from the building to the street of 2% and building openings a minimum of 0.3m above the 100-year ponding level. If reduced lot grading is considered for an increase in travel time and infiltration, the 2% minimum grade is still maintained for at least 4m from the building.
- The maximum water depth on streets (public, private and parking lots), static or dynamic, is 350 mm.
- Where underground storage is utilized, the design must ensure that backwater from the downstream system does not impact the required storage.

In addition to the City of Ottawa’s guidelines, requirements for storm water quality control will be considered. The Rideau Valley Conservation Authority (RVCA) has been consulted (**Appendix B**) and indicated as follows:

- Building roof areas can be excluded from storm water quality treatment systems due to the “clean” water being discharged from the roof as opposed to that being discharged from ground surface areas.
- The remaining setback areas contains fewer than 6 parking spaces, and therefore do not require quality control.
- The RVCA recommends opportunities and options for suitable source and conveyance controls to be considered, including LID techniques, that will assist with managing/improving the quality of runoff from this site

5.3.2 Stormwater Quantity Control

5.3.2.1 Runoff Coefficient and Peak Flows

Table 6 indicates the run-off coefficient for each catchment. The 100-year run-off coefficients include a 25% increase (to a maximum of 1.0) as required by the City of Ottawa Sewer Design Guidelines Section 5.4.5.2.1.

Table 6– Pre-development Run-off Coefficients

Storm Event	Pre-Development Run-off Coefficients	
	5-Year Storm	100-Year Storm
Site Area (in ha)	0.159	0.159
Run-off Coefficients	0.90	1.0

Intensity (i) is calculated using the formula

$$i = \frac{A}{(T_d + C)^B}$$

where A, B and C are all factors of the IDF Return Period, T_d being the time of concentration and A the drainage area (Detailed calculations provided in **Appendix E**).

Time of concentration is determined using the inlet time graph (Appendix 5D Ottawa City Sewer Design Guidelines) which results in a values less than 10 minutes. Therefore 10 minutes will be used to calculate peak flows. With the pre and post-development run-off coefficients and rainfall intensity, the peak flows for each drainage area can be calculated using the Rational Method. The results (using actual run-off coefficients) are summarized in **Table 7**.

Table 7– Pre-Development Peak Flows

Storm Event	Pre-Development Peak Flows (actual run-off coefficients)	
	5-Year Storm	100-Year Storm
Intensity (mm/hr)	104.2	178.6
Peak Flow (L/s)	41.6	79.1

Since the pre-development run-off coefficient exceeds 0.5, a value of 0.5 will be assumed for calculation of the allowable release rate. Considering time of concentration of 10 minutes, site area of 0.159 hectares and a 5 year storm, **the allowable release rate is 23.1 L/s**.



The project will result in all catchments remaining covered with impervious surfaces. The post-development run-off coefficients are indicated in **Table 8**:

Table 8– Overall Post-Development Run-off Coefficients

Storm Event	Overall Post-Development Run-off Coefficients	
	5-Year Storm	100-Year Storm
Project Area (in ha)	0.159	0.159
Weighted Run-Off Coefficient	0.90	1.00

5.3.2.2 Stormwater Management Concept

Uncontrolled Drainage Areas (RAMP, SB1, SB3)

It is not feasible to control run-off from the setback areas along Aylmer Ave. and Bank Str., as such these area will release uncontrolled to the adjacent ROW.

The base of the access ramp to the underground parking area is too low to drain by gravity to the existing storm sewers. Run-off from the ramp will therefore be captured and pumped. So as to allow one set of pumps to service both the ramp and the foundation drains, the pump discharge will be directed downstream of the ICD and released uncontrolled.

Table 9– Post-Development Uncontrolled Release

Storm Event	Post-Development Uncontrolled Release	
	5-Year Storm	100-Year Storm
Drainage area (ha)	0.042	0.042
Run-off Coefficient	0.9	1.0
Peak Flow (L/s)	10.8	20.7

This leaves a remaining allowable release rate of **2.4 L/s**.

The pumps will be located inside the building and will be designed by the mechanical engineer. The pumps will be sized to provide capacity equal to the peak run-off from the ramp during the 100 year storm (i.e. 6.4 L/s).

Controlled Drainage Areas BLDG1, BLDG2, SB2, SB4

The drainage from the roof, western setback (rear parking area) and southern setback (Euclid Ave.) will be captured and directed to an underground storage tank located in the western setback. The tank will outlet to a catchbasin maintenance hole outfitted with an ICD. Downstream of the ICD the storm service will outlet to the existing 375mm storm sewer in Bank Str..

As indicated by the proposed storage calculations, the required underground storage is 59m³. This will be provided using a rectangular plastic geocellular stormwater storage tank. Assuming a void ratio of 0.95 (as per documentation for a typical tank in **Appendix E**), the required tank dimensions are 21.6m long by 2.4m wide by 1.2m tall. Operation and maintenance requirements for the specified ACO Stormbrixx tank are provided in the **Appendix E**.

Based on the orifice calculation, the outlet will require a vortex inlet control device. Using an allowable release rate of 2.4L/s and a head of 1.33m, the “*IPEX Tempest LMF ICD*” meets the requirements at a preset of 50. The ICD design chart is provided in **Appendix E**.



Summary

Table 10 summarizes the proposed release rates and confirms that the total release rate does not exceed the allowable release rate.

Table 10 – Post-Development Controlled Peak Flows

	Post-Development Controlled Peak Flows (L/s)
Allowable Release Rate	23.1
Release Rate from Uncontrolled Drainage Areas	20.7
Release Rate from Controlled Drainage Areas	2.4
Total Release Rate	23.1

5.3.2.3 Impact on Existing Stormwater Infrastructure

An existing 375 mm storm sewer with a slope of 0.5% services Bank Street between Aylmer Avenue and Euclid Avenue. **Table 11** summarizes the existing flows to the public storm sewer.

Table 11 – Pre-Development Peak Flows vs. Post-Development Controlled Peak Flows

	Pre-Development Peak Flow	Post-Development Controlled Peak Flow
Storm Event	5-Year Storm	5-Year Storm
Peak Flow / Reduced Release Rate (L/s)	41.6	23.1
Total run-off (L/s)	41.6	23.1

This shows a reduction in total run-off of 64.6% when compared to the uncontrolled pre-development peak flow.

Sewer Design Calculations are provided in **Appendix E**.

5.3.3 Storm Water Quality Control

As indicated in **Section 5.3.1** above, the RVCA considers run-off from building roof areas to be “clean”, and therefore not require quality control.

As there are fewer than 6 proposed parking spaces parallel to the municipal laneway, this area does not require quality control.

The RVCA correspondence regarding water quality has been included in **Appendix B**.

5.3.4 Pre-Consultation with the Ontario Ministry of the Environment and Conservation and Parks, and Conservation Authority

The Ministry of Environment, Conservation and Parks (MECP) has been contacted and has confirmed that no ECA is required for this site. Correspondence is provided in **Appendix B**.

5.3.5 Minor and Major Systems

The minor storm sewer system consists of the sewers described above. The major system consists of flow north along Bank Street toward the Rideau Canal. The site will be graded to direct run-off from storms in excess of the 100-year event to Bank Street. Run-off from the rear of the site will reach Bank Street via the rear passage (laneway), and Aylmer or Euclid Avenue.



5.3.6 Impacts to Receiving Watercourses

No negative impacts to receiving watercourses are anticipated.

5.3.7 100 Year Flood Levels and Major Flow Routing

The site is not within a 100-year floodplain.

5.4 Grading

The proposed grading plan is shown in Drawing C002 in **Appendix A**. The development will be tied into existing sidewalk grades along Bank Street, Aylmer Avenue and Euclid Avenue.

The west side of the site fronts a City-owned rear passage (laneway). It is apparent that the rear passage was previously partially excavated to provide access from 1060 Bank Street to a property west of the rear passage with PIN 041430324 (also identified as 1060 Bank Street, though not fronting onto Bank Street). As a result of this excavation, it is currently not possible to drive along the rear passage from Aylmer Avenue to Euclid Avenue. During construction of the proposed development, the rear passage will be reinstated by the developer. To maintain drainage, the previously-excavated portion of PIN 041430324 will be filled to slope towards the rear passage. No other development of PIN 041430324 is proposed at this time.

The proposed setback/parking area on the west side of the proposed development will be graded away from the rear passage to prevent run-off onto the rear passage. The rear passage will be graded with a crossfall to the west and longitudinal slopes from a high point towards Aylmer Avenue and Euclid Avenue to maintain drainage of the properties to the west, including PIN 041430324.

5.5 Erosion and Sediment Control

As described in the servicing guidelines, an erosion and sediment control plan is required for implementation during the construction phase. To minimize the migration of sediments, items such as silt fencing and sediment capture devices for catch-basins downstream of the site and around the building are to be installed to capture and retain sediment. Additionally, all stockpiles are to be covered.

During construction, all erosion control features shall be maintained and repaired as necessary and adjacent roadways kept free of construction debris and sediment this responsibility falls under the purview of the Contractor.



6 Conclusions

In conclusion the proposed development meets all required servicing constraints and associated design criteria/requirements as well as the additional City of Ottawa requirements identified in the pre-consultation phase. It is recommended that this report be submitted to the City of Ottawa in support of the application for site plan approval.

Sincerely,

Morrison Hershfield Limited



James Fookes, P.Eng., C.Eng.
Senior Water and Wastewater Engineer

A handwritten signature in blue ink that reads "Daniel Glauser".

Daniel Glauser, B.Eng.
Municipal Designer

7 Appendices

Appendix A	Site Servicing, Grading and Erosion and Sediment Control, Catchments Plans and Details
Appendix B	Correspondence with Regulatory Authorities
Appendix C	Water Demand and FUS Calculations
Appendix D	Sanitary Flow Calculations
Appendix E	Storm Sewer Design Calculations
Appendix F	Site Servicing Checklist
Appendix G	Topographic and Legal Survey

Appendix A

Site Servicing, Grading and Erosion and Sediment Control, Catchments Plans and Details

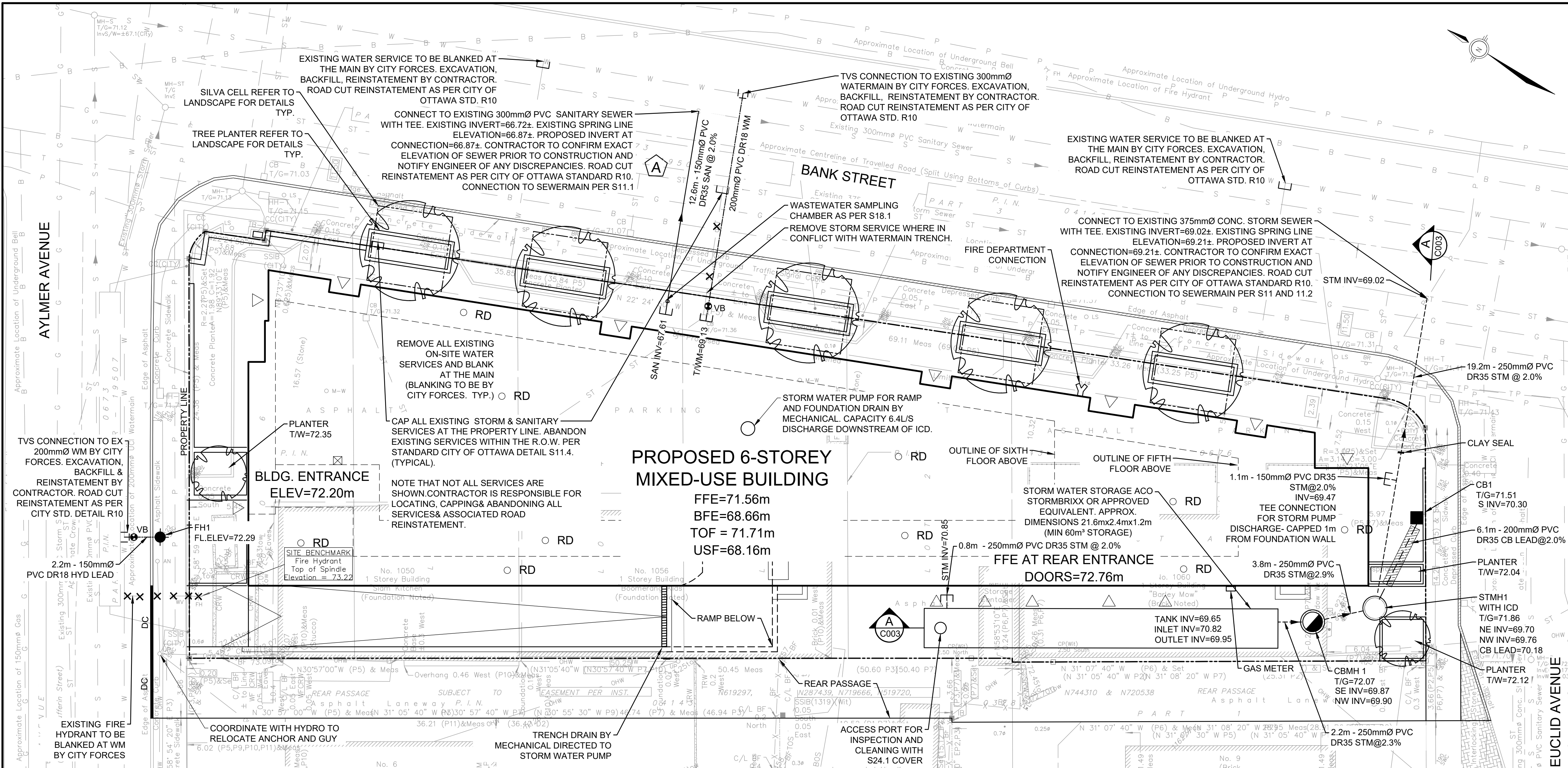

PROPOSED MIXED-USE RETAIL & RENTAL APARTMENT BUILDING
1050&1060 BANK STREET
OTTAWA, ON

SITE SERVICING PLAN

Contract No. C001
Sheet No. 1 of 5
Asset No.
Asset Group

Des: DG Chk'd: JF
Dwn: NI Chk'd: JF
Utility Circulation No.: CTY---
Construction Inspector:
Scale: 1:150
0m HORIZONTAL 2.5 5

PROFESSIONAL ENGINEER
J.G. FOOKEE
2020/12/15
PROVINCE OF ONTARIO

NOTE:
The location of utilities is approximate only, the exact location should be determined by consulting the municipal authorities and utility companies concerned. The contractor shall provide the location of utilities and shall be responsible for adequate protection from damage.

MORRISON HERSHFELD
200-2932 BASELINE RD.
OTTAWA, ON K2H 1B1

REVISIONS

No.	Description	By	Date (dd/mm/yyyy)
0	ISSUED FOR SITE PLAN APPROVAL	J.F.	02/12/19
1	RE-ISSUED FOR SITE PLAN APPROVAL	J.F.	15/12/20

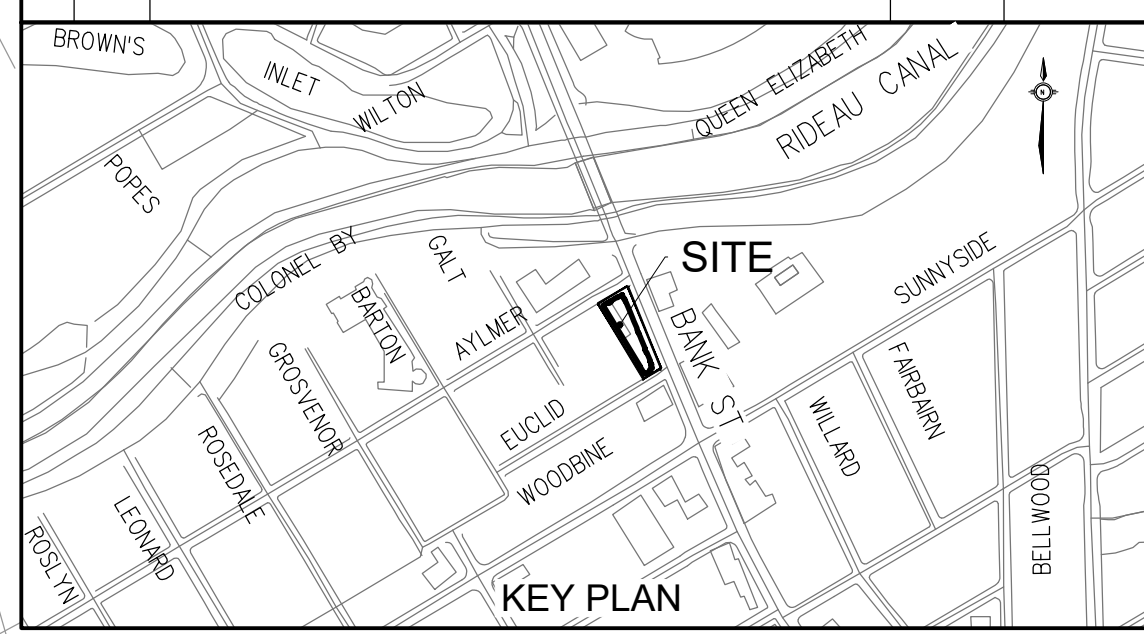

LEGEND

- NEW WATERMAIN
- NEW SANITARY SEWER
- NEW STORM SEWER
- NEW MANHOLE
- NEW VALVE AND VALVE BOX
- NEW HYDRANT
- NEW CAP
- NEW CATCH BASIN
- NEW STORM CB LEAD
- NEW ENTRANCE
- NEW FIRE DEPARTMENT CONNECTION
- NEW ROOF DRAIN
- NEW THERMAL INSULATION FOR SHALLOW SEWERS
- EXISTING STORM SEWER
- EXISTING SANITARY SEWER
- EXISTING WATERMAIN
- EXTENTS OF SILVA CELL, REFER TO LANDSCAPE FOR DETAILS
- PLANTER CURB (RIBBON CURB), REFER TO LANDSCAPE FOR DETAILS

NOTES:
GENERAL

- COORDINATES ARE IN MTM ZONE 9 (76°30' WEST LONGITUDE) NAD-83 (ORIGINAL)
- OBTAIN ALL NECESSARY PERMITS AND APPROVALS FROM THE CITY OF OTTAWA PRIOR TO STARTING CONSTRUCTION
- ALL MATERIALS AND CONSTRUCTION TO BE IN ACCORDANCE WITH CURRENT CITY OF OTTAWA STANDARDS AND ONTARIO PROVINCIAL STANDARDS AND SPECIFICATIONS (OPSS & OPSD)
- SERVICES ARE TO BE CONSTRUCTED TO 1.0m FROM FACE OF BUILDING
- REFER TO "SITE SERVICING AND STORMWATER MANAGEMENT DESIGN BRIEF, 1050&1060 BANK STREET, MIXED-USE DEVELOPMENT" PREPARED BY MORRISON HERSHFELD FOR SITE SERVICING REPORT
- REFER TO GEOTECHNICAL INVESTIGATION REPORT (NO. PG4506-1 DATED APRIL 8, 2020) PREPARED BY PATERSON GROUP FOR SUBSURFACE CONDITIONS, CONSTRUCTION RECOMMENDATIONS AND GEOTECHNICAL INSPECTION REQUIREMENTS. THE GEOTECHNICAL CONSULTANT SHALL REVIEW EXCAVATIONS PRIOR TO THE PLACEMENT OF GRANULAR MATERIAL
- CONTRACTOR TO VERIFY ALL EXISTING UTILITY ELEVATIONS AT CONNECTION AND CROSSING LOCATIONS PRIOR TO CONSTRUCTION AND ADVISE THE ENGINEER OF ANY DISCREPANCIES
- UNLESS DIRECTED OTHERWISE ANY DAMAGED ASPHALT OR CURB (REGARDLESS OF WHETHER WITHIN OR EXTERNAL TO THE SITE) SHALL BE REINSTATED IN ACCORDANCE WITH CITY STD. DET. R10 AND S1
- UNLESS DIRECTED OTHERWISE THE CONTRACTOR SHALL REINSTATE ALL SIGNS, LIGHTING AND OTHER STREET FURNITURE DISTURBED BY THE WORK
- THE CONTRACTOR SHALL DEVELOP AND IMPLEMENT TRAFFIC MANAGEMENT PLANS FOR WORK IN RIGHT OF WAY IN ACCORDANCE WITH OTM BOOK 7.

- CLAY SEALS SHALL BE IN ACCORDANCE WITH CITY OF OTTAWA STANDARD DETAIL S8 AND SHALL BE INSTALLED AT 50m INTERVALS IN ALL PIPE TRENCHES. CLAY SEAL TO EXTEND FULL TRENCH WIDTH AND FROM BOTTOM OF TRENCH EXCAVATION TO UNDERSIDE OF ROAD STRUCTURE, WITH A MINIMUM THICKNESS OF 1m ALONG PIPE
- LOCATE AND CAP ALL EXISTING STORM, SANITARY AND WATER SERVICES AT THE PROPERTY LINE. ABANDON EXISTING SERVICES WITHIN THE R.O.W. PER STANDARD CITY OF OTTAWA DETAIL S11.4 (TYPICAL)
- REFER TO ARCHITECTURAL DRAWINGS FOR EXACT ROOF DRAINAGE LAYOUT

SEWERS

- ALL STORM SEWERS, SANITARY SEWERS AND CATCH BASINS LEADS SHALL BE PVC DR 35 UNLESS OTHERWISE SPECIFIED
- REFER TO DETAIL 1 ON DRAWING C003 FOR SEWER INSTALLATION. MAINTENANCE HOLES AND CATCH BASIN MAINTENANCE HOLES ON STORM SEWERS LESS THAN 900mm DIAMETER SHALL BE CONSTRUCTED WITH A 300mm SUMP. BENCHING SHALL BE INSTALLED IN MAINTENANCE HOLES ON STORM SEWERS 900mm AND ABOVE
- STORM SEWER MAINTENANCE HOLE COVERS SHALL BE IN ACCORDANCE WITH CITY OF OTTAWA STANDARD DETAIL S24.1 ON FRAMES TO DETAIL S25
- CONTRACTOR SHALL MAINTAIN EXISTING SEWER FLOWS DURING CONSTRUCTION IN ACCORDANCE WITH CITY OF OTTAWA SPECIFICATIONS
- ALL MAINTENANCE HOLES, CATCHBASINS AND CLEANOUTS SHALL BE ADJUSTED TO POST-CONSTRUCTION GRADE
- CCTV INSPECTION OF ALL SEWERS SHALL BE COMPLETED AS PER CITY OF OTTAWA SPECIFICATIONS PRIOR TO THE INSTALLATION OF BASE COURSE ASPHALT
- BACKWATER VALVES TO BE INSTALLED AS PER CITY OF OTTAWA STANDARD S14 & S14.2

WATERMANS

- REFER TO DETAIL 1 ON DRAWING C003 FOR WATERMAIN INSTALLATION
- ALL WATERMAIN MATERIALS AND CONSTRUCTION METHODS SHALL BE IN ACCORDANCE WITH THE 2019 EDITION OF THE CITY OF OTTAWA STANDARD SPECIFICATIONS AND STANDARD DRAWINGS. PVC PIPE TO BE CLASS 150 DR18 TO LATEST EDITION OF A.W.W.A. SPECIFICATION C900 AND CSA B137.3 LATEST AMENDMENT WITH GASKETED BELL AND SPIGOT COUPLINGS
- THE CONTRACTOR SHALL BE RESPONSIBLE FOR OBTAINING A WATER PERMIT AS REQUIRED FROM THE CITY OF OTTAWA, AND COMPLYING WITH ALL CITY OF OTTAWA REQUIREMENTS. THE CITY MAY REQUIRE THAT CERTAIN ACTIVITIES (E.G. VALVE OPERATION, CONNECTION OF NEW WATER SERVICE TO EXISTING WATERMAIN, DISINFECTION) BE CARRIED OUT ONLY BY CITY FORCES
- ALL VALVES 300mm DIAMETER AND SMALLER SHALL INCLUDE A VALVE BOX AS PER W24
- THE NEW WATERMAIN IS TO BE INSTALLED WITH A MINIMUM OF 2.4m COVER (INCLUDING HYDRANT LEAD), WHERE 2.4m COVER IS NOT POSSIBLE, PROVIDE INSULATION IN ACCORDANCE WITH CITY OF OTTAWA STANDARD DETAILS W22 & W23
- THRUST RESTRAINT SHALL BE PROVIDED BY BOTH RESTRAINING/RETAINING RINGS AND THRUST BLOCKS AT ALL DEAD END CAPS, PLUGS, VALVES, BENDS AND REDUCERS AS PER CITY OF OTTAWA STANDARD DETAILS W25.3, W25.4, W25.5 AND W25.6. ALL TEMPORARY THRUST RESTRAINTS ARE THE RESPONSIBILITY OF THE CONTRACTOR
- TRACER WIRE SHALL BE PROVIDED FOR ALL NEW PVC WATERMANS IN ACCORDANCE WITH THE SPECIFICATIONS AND CITY OF OTTAWA STANDARD DETAIL W36
- CATHODIC PROTECTION SHALL BE PROVIDED FOR ALL NEW WATERMANS IN ACCORDANCE WITH THE SPECIFICATIONS AND CITY OF OTTAWA STANDARD DETAILS W39, W40, W41, W42 AND W47. CATHODIC PROTECTION OF EXISTING WATERMANS SHALL ALSO BE PROVIDED AT CONNECTIONS BETWEEN EXISTING AND NEW WATERMANS
- ADJUST ALL VALVE CHAMBERS, VALVE BOXES AND HYDRANTS TO FINISHED GRADE

UTILITY NOTE

- THE POSITION OF POLE LINES, CONDUITS, WATERMANS, SEWERS AND OTHER UNDERGROUND AND OVERGROUND UTILITIES AND STRUCTURES IS NOT NECESSARILY SHOWN ON THE CONTRACT DRAWING, AND, WHERE SHOWN, THE ACCURACY OF THE POSITION OF SUCH UTILITIES AND STRUCTURES IS NOT GUARANTEED. BEFORE STARTING WORK THE CONTRACTOR SHALL INFORM HIMSELF OF THE EXACT LOCATION OF ALL SUCH UTILITIES AND STRUCTURES, AND SHALL ASSUME ALL LIABILITY FOR DAMAGE TO THEM. THE CONTRACTOR WILL BE RESPONSIBLE FOR SUPPORTING AND PROTECTING ANY EXISTING UTILITIES, AS REQUIRED, IN ACCORDANCE WITH THE UTILITY OWNERS' REQUIREMENTS. CONTRACTOR IS REQUIRED TO OBTAIN LOCATES, IN ADVANCE OF EXCAVATION WORK, AND FORWARD COPIES OF THE LOCATES TO THE CONSULTANT AND THE OWNER PRIOR TO EXCAVATION
- ALL CROSSING OF EX. UTILITIES TO BE IN ACCORDANCE WITH CITY STD. DET. S10

PIPE CROSSING TABLE

CROSSING	LOWER PIPE	HIGHER PIPE	CLEARANCE	SURFACE ELEVATION
A	150mmØ SAN OBV=66.94	375mmØ STM INV=69.28	2.3m±	71.09m

PROPOSED HYDRANT LEAD TABLE

STATION	SURFACE ELEVATION	T/WM ELEVATION	COMMENTS
0+000	72.04	69.64±*	TVS CONNECTION TO EXISTING 200mmØ WATERMAIN
0+001.5	72.18	69.78±	200mmØ VALVE AND VALVE BOX
0+003.0	72.23	69.83±	HYDRANT

PROPOSED WATER SERVICE TABLE

STATION	SURFACE ELEVATION	T/WM ELEVATION	COMMENTS
0+000	71.70	68.70±*	TVS CONNECTION TO EXISTING 300mmØ WATERMAIN
0+001.5	71.11	68.71±	CROSS ABOVE 300mmØ SAN (1.7m± CLEARANCE)
0+005.9	71.10	68.70±	CROSS ABOVE 375mmØ STM (0.6m± CLEARANCE)
0+013.0	71.48	69.08±	200mmØ VALVE AND VALVE BOX
0+014.6	71.53	69.13±	CAP 1.0m FROM BUILDING FACE

* TVS CONNECTION TO EXISTING 300mmØ WATERMAIN. EXACT ELEVATION TO BE FIELD DETERMINED.

NEW STORM STRUCTURE

STRUCTURE	STRUCTURE TYPE	COVER TYPE	TOP OF GRATE	INVERT	NORTHING	EASTING	NOTES
MHST1	701.010	S24.1	71.86	69.70 (NE) 69.76 (NW)	5028644.29	368687.58	WITH ICD
CBMH1	701.010	S19	72.07	69.90 (NW) 69.87 (SE)	5028647.12	368684.90	
CB1	705.010	S19	71.51	70.30 (SW)	5028644.91	368693.63	

INLET CONTROL DEVICE DATA TABLE - STMH1

DESIGN EVENT	ICD TYPE	DIAMETER OF OUTLET PIPE (mm)	DESIGN FLOW (L/s)	WATER ELEVATION (m)	REQUIRED VOLUME (m³)	TOTAL VOLUME PROVIDED
1:5 YR	IPEX Tempest LMF 50	250mmØ PVC	2.0	70.73	31.9	60m³
1:100 YR	IPEX Tempest LMF 50	250mmØ PVC	2.4	71.15	59.0	

No.	Description	By	Date (dd/mm/yy)
0	ISSUED FOR SITE PLAN APPROVAL	J.F.	02/12/19
1	RE-ISSUED FOR SITE PLAN APPROVAL	J.F.	24/09/20

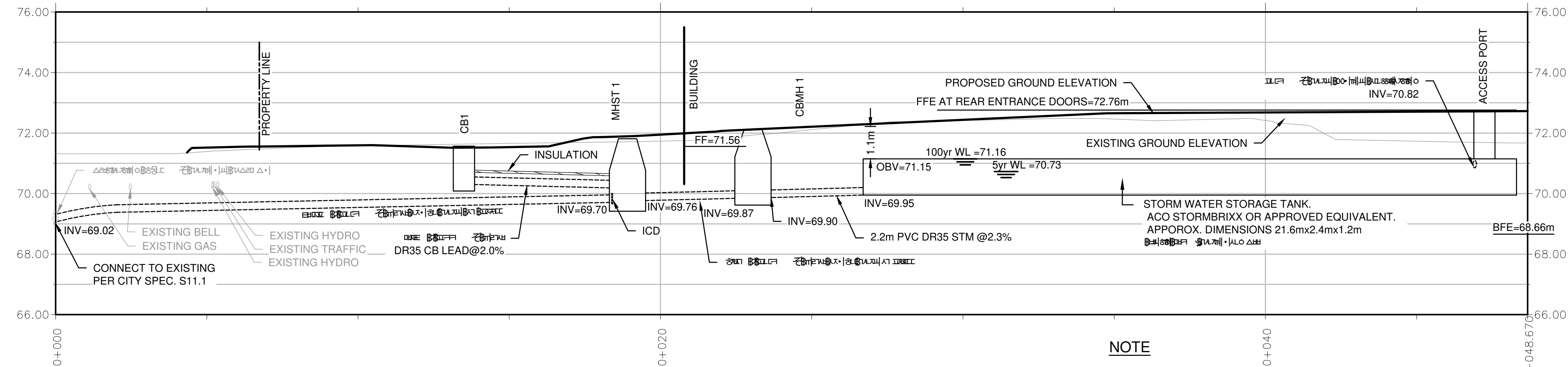
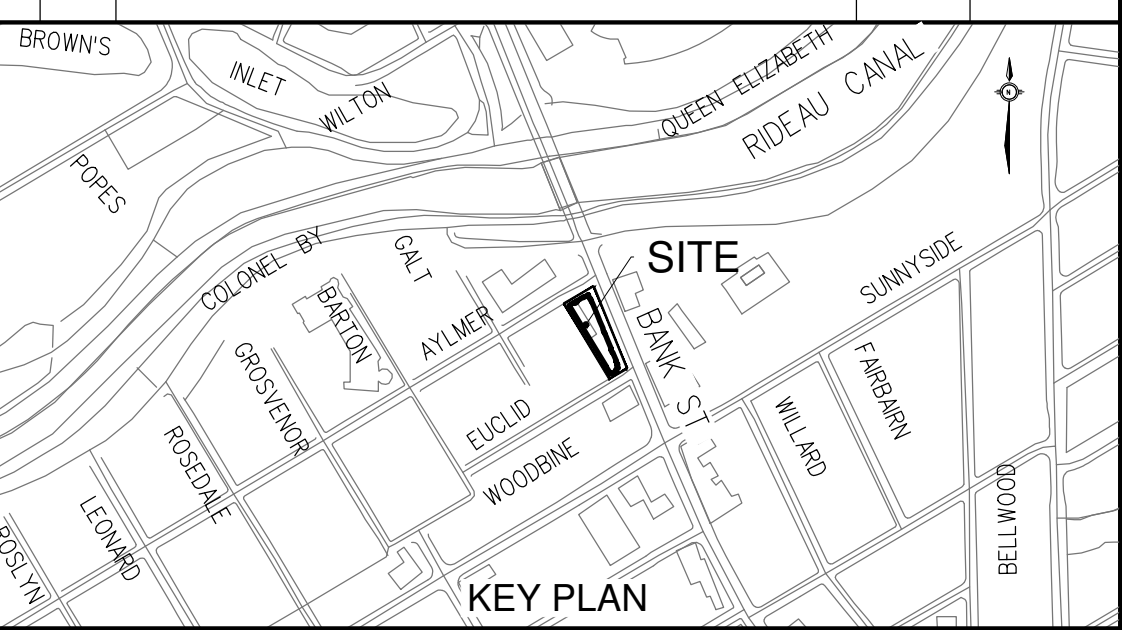

SECTION A - A
SCALE 1:100

NOTE
GEO TECHNICAL REPORT (NO. PG 4506-1 DATED APRIL 8, 2020) PREPARED BY PATERSON GROUP, INDICATES GROUNDWATER TO BE 11-12m BELOW GRADE. HOWEVER AN IMPERMEABLE LINER IS REQUIRED FOR THE STORM WATER STORAGE TANK TO PREVENT EXFILTRATION FROM THE TANK IN THE VICINITY OF THE PERIMETER FOUNDATION DRAIN OF THE PROPOSED BUILDING.

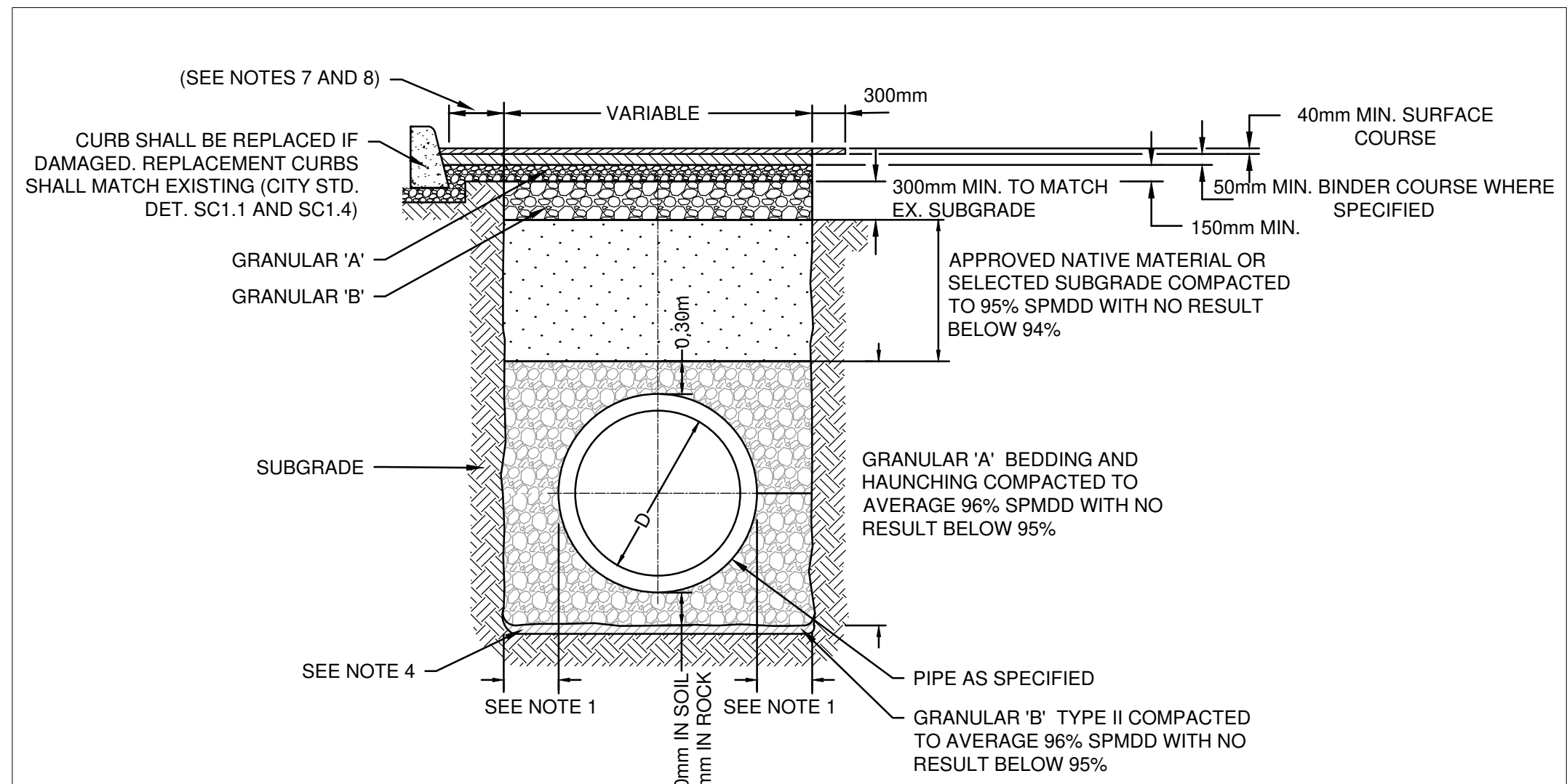

NOTES:

PIPE INSIDE DIAMETER (mm)	CLEARANCE (mm)
900 OR LESS	CONC 450 PVC 450
OVER 900	500

- FINAL BACKFILL - APPROVED NATIVE MATERIAL OR SELECT SUBGRADE
- ALL DIMENSION ARE IN MILLIMETERS UNLESS SHOWN OTHERWISE.
- WHEN NECESSARY POOR SOILS SHALL BE EXCAVATED TO CREATE A FOUNDATION THAT SHALL BE FILLED TO THE BOTTOM OF THE BEDDING WITH GRANULAR 'B'.
- THE USE OF CLEAR CRUSHED STONE AS A BEDDING LAYER IS NOT PERMITTED ANYWHERE ON THIS SITE.
- ALL EXISTING ASPHALT AND CONCRETE REMOVAL LIMITS TO BE SAWCUT.
- 300 MM KEY TO BE SAWCUT AND REMOVED OR MILLED.
- ROAD REINSTATEMENT ON THE CURB SIDE OF THE TRENCH EXCAVATION SHALL EXTEND TO THE CURB FACE.
- TACK COAT SHALL BE APPLIED TO ALL MILLED SURFACES

1 WATERMAIN AND SEWER INSTALLATION
C001 TYPICAL DETAIL
N.T.S.

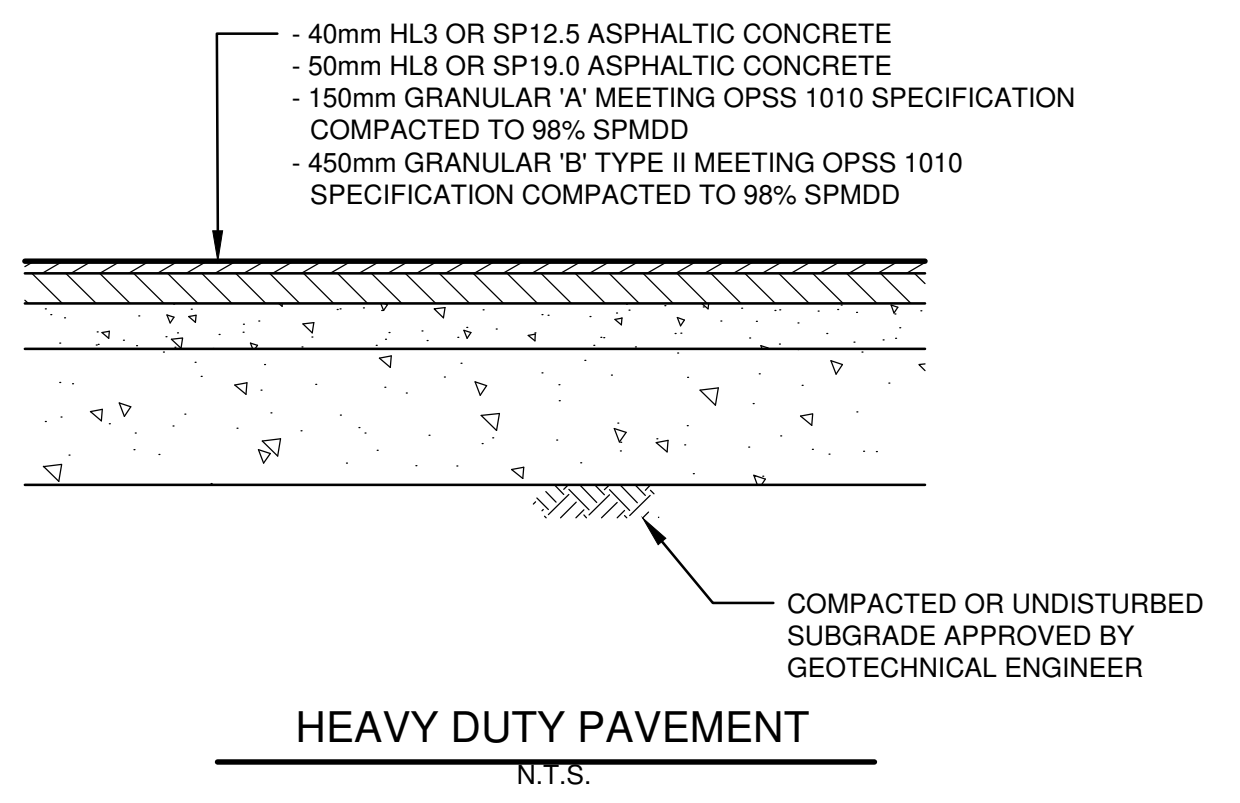

INSULATION NOTE

THE THICKNESS OF SEWER INSULATION SHALL BE THE EQUIVALENT OF 25mm FOR EVERY 300mm REDUCTION IN THE REQUIRED DEPTH OF COVER LESS THAN 1500mm (SEE TABLE BELOW)

Ti=THICKNESS OF INSULATION (mm)
H=DEPTH OF COVER
W=D+300 (1000 MIN.)
W=WIDTH OF INSULATION (mm)
D=O.D. OF PIPE (mm)

COVER (mm)	INSULATION THICKNESS (mm)
1500-1200	75
1200-900	100
900-600	125

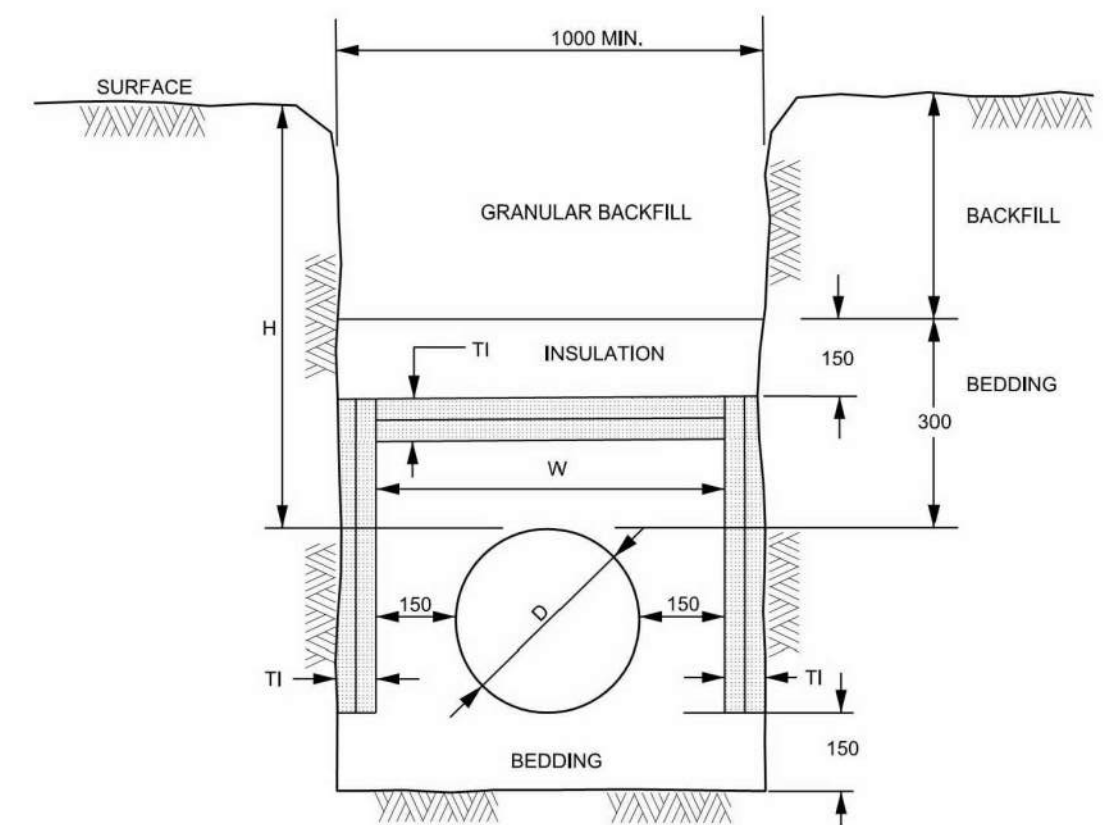

INSULATION DETAIL FOR SHALLOW SEWERS
N.T.S.

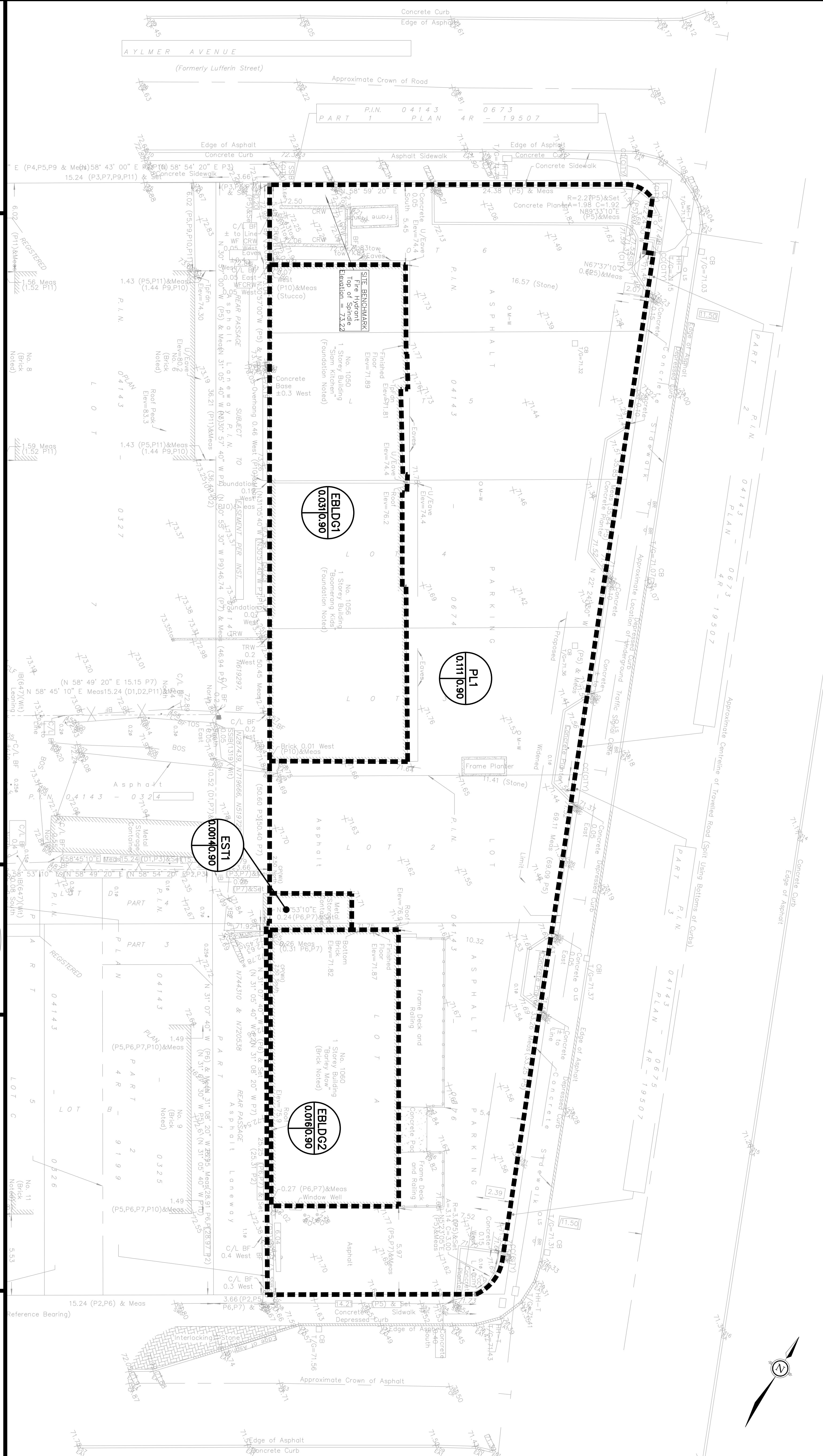

MORRISON HERSHFIELD

**1050 AND 1060 BANK STREET
PROPOSED STORM DRAINAGE AREA PLAN**

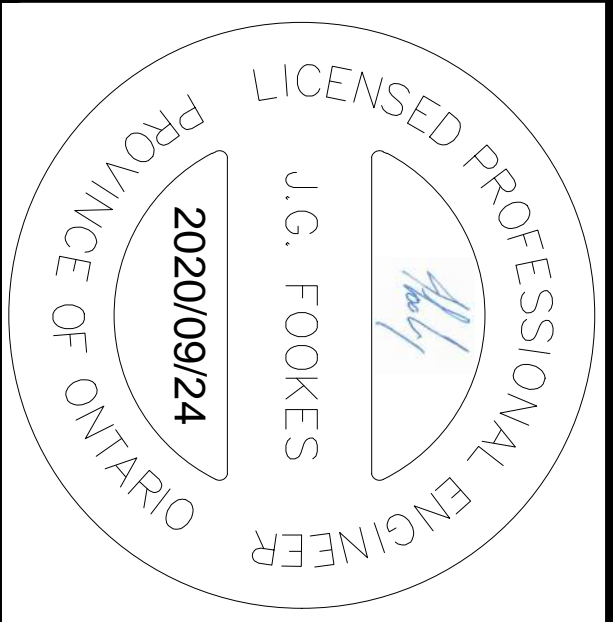

LEGEND

AREA ID	DRAINAGE AREA CHARACTERISTICS
	DRAINAGE AREA CHARACTERISTICS
	RUNOFF COEFFICIENT %
	AREA ha

C004

DATE: 2020-09-24

SCALE: N.T.S.

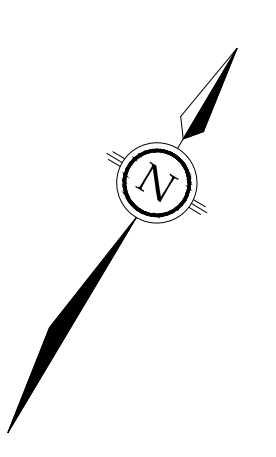

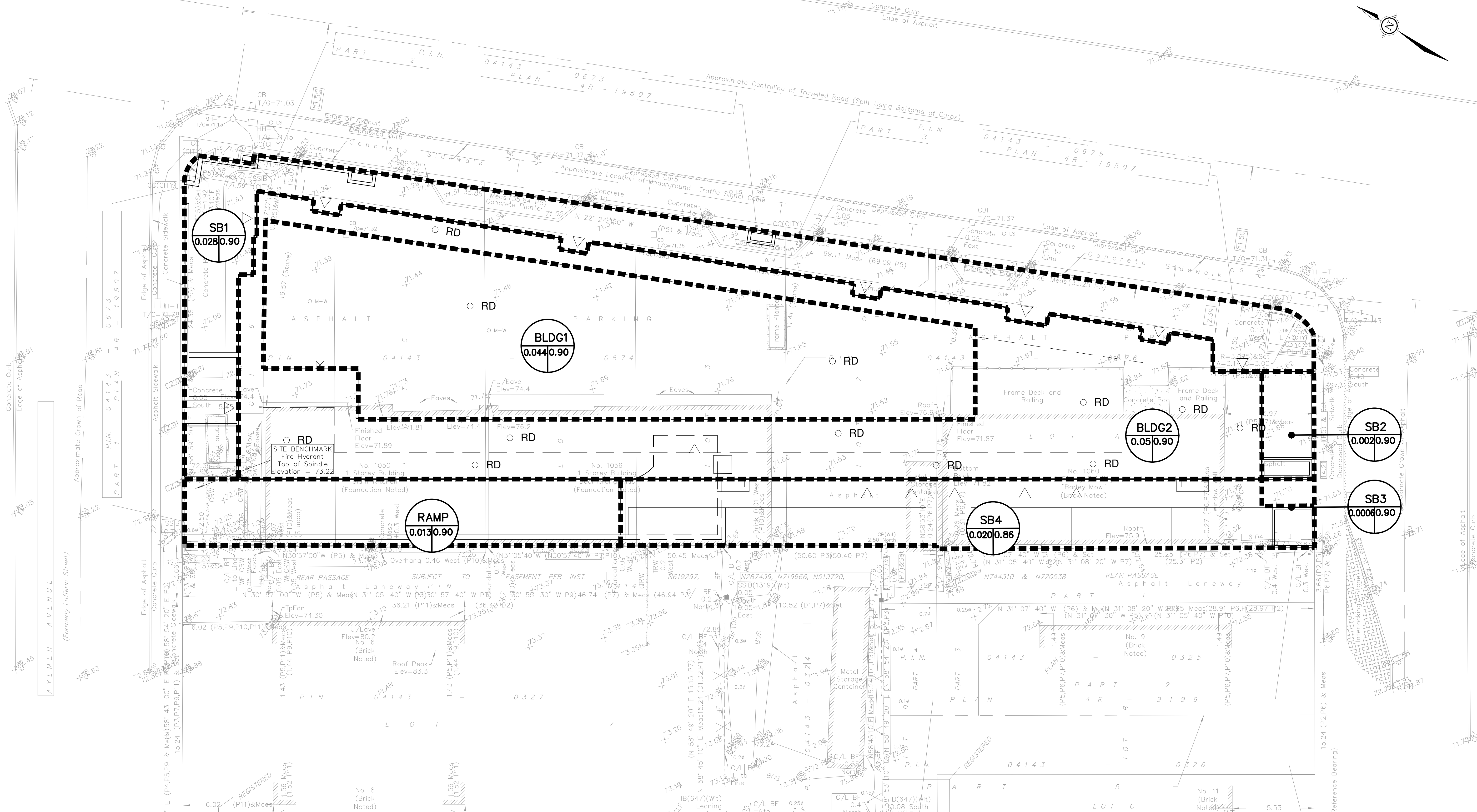
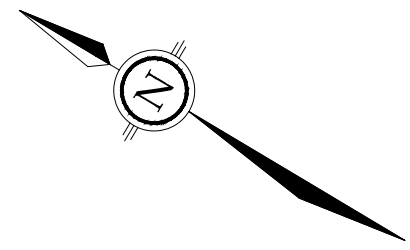

1050 AND 1060 BANK STREET PROPOSED STORM DRAINAGE AREA PLAN



LEGEND

AREA ID		DRAINAGE AREA CHARACTERISTICS
RUNOFF COEFFICIENT %		AREA ha

C005

DATE: 2020-09-24

SCALE: N.T.S.

Appendix B

Correspondence with Regulatory Authorities

Daniel Glauser

From: Des Rochers, Christina (MECP) <Christina.Desrochers@ontario.ca>
Sent: Thursday, September 26, 2019 9:25 AM
To: James Fookes
Cc: Daniel Glauser
Subject: RE: 1050-1060 Bank Street

Thanks James,

Based on the information provided below, the local office does not believe an ECA is required for the proposed project.

Regards.

Christina Des Rochers

Water Inspector | Inspectrice de l'eau

Safe Drinking Water Branch | Direction du contrôle de la qualité de l'eau potable

Ministry of the Environment, Conservation and Parks | Ministère de l'Environnement, de la Protection de la nature et des Parcs

Tel. 613-521-3450 ex. 231

Fax. 613-521-5437

Spills Action Centre | Centre d'intervention en cas de déversement 1-800-268-6060

Please consider the environment before printing this email note

From: James Fookes <JFookes@morrisonhershfield.com>
Sent: September-25-19 12:39 PM
To: Des Rochers, Christina (MECP) <Christina.Desrochers@ontario.ca>
Cc: Daniel Glauser <DGlauser@morrisonhershfield.com>
Subject: 1050-1060 Bank Street

Hi Christina,

We are designing site servicing for a mixed-use Development located at 1050-1060 Bank Street ([Link to Map location](#)). The proposed development consists of a six story mixed-use building, where floors 2-5 are residential, floor 1 is retail and the parking garage in the basement. The existing single-story commercial buildings on the site will be demolished. Behind the building there will be a few parking spaces located in a municipal laneway. Stormwater from the site will be directed into an existing storm sewer in Bank Street which outlets to the Rideau River via Sunnyside Avenue (existing 1350 Conc. storm sewer on the south boundary of Leonard Ave.). I've attached an overview of the municipal storm sewers with the proposed site in red and the drainage route in orange. Sanitary servicing will be via the existing sanitary sewer on Bank Street.

The City has requested that we obtain confirmation from the MECP of whether an ECA is required for the development. I believe that the reason they are asking for this is because a section of the trunk sanitary sewer downstream of the site is shown in orange on GeoOttawa (indicating classification as a combined sewer – shown in the attached jpg). However, the site is not in a combined sewer area, and storm drainage is by a separated sewer to the Rideau River.

The RVCA has confirmed that stormwater quality control is not required for the site.

The owner will consolidate the two property parcels into one before proceeding with the development. We intend to design the grading and drainage so that drainage of the lane at the rear of the property is separate to drainage of the property.

Our understanding is therefore that an ECA will not be required. Please confirm whether this is correct.

Thanks and regards,
James

James Fookes, P.Eng.

Department Manager, Municipal Infrastructure

jfookes@morrisonhershfield.com



200 – 2932 Baseline Road | Ottawa, ON K2H 1B1 Canada

Dir: 613 739 2910 x1022225 | Cell: 613 869 9592 | Fax: 613 739 4926

morrisonhershfield.com

Did You Know? Same smart people. Shiny new office. Take a peek inside our new Ottawa office at 200 - 2932 Baseline Road, Ottawa, ON K2H 1B1. [Watch video.](#)

Daniel Glauser

From: Jamie Batchelor <jamie.batchelor@rvca.ca>
Sent: Wednesday, September 25, 2019 10:46 AM
To: Daniel Glauser
Cc: James Fookes
Subject: RE: Mixed-Use Development; 1050-1060 Bank Str.

Good Morning Daniel,

Based on the plans provided, majority of the parking is in an underground parking garage. There is only a few exterior parking spaces proposed in the municipal laneway (less than 6). Therefore, this redevelopment will be primarily roof top area receiving rainwater. Roofs and landscaped areas, for the purpose of protecting surface water and aquatic habitat, are considered clean. The RVCA therefore accepts that the stormwater runoff from this site does not require any additional water quality measures.

Jamie Batchelor, MCIP, RPP
Planner, ext. 1191
Jamie.batchelor@rvca.ca



3889 Rideau Valley Drive
PO Box 599, Manotick ON K4M 1A5
T 613-692-3571 | 1-800-267-3504 F 613-692-0831 | www.rvca.ca

This message may contain information that is privileged or confidential and is intended to be for the use of the individual(s) or entity named. If you are not the intended recipient of this e-mail, any use, review, revision, retransmission, distribution, dissemination, copying, printing or taking of any action in reliance upon this e-mail, is strictly prohibited. If you have received this e-mail in error, please contact the sender and any copy of the e-mail and any printout thereof, immediately. Your cooperation is appreciated.

From: Daniel Glauser <DGlauser@morrisonhershfield.com>
Sent: Wednesday, September 18, 2019 3:26 PM
To: Glen McDonald <glen.mcdonald@rvca.ca>
Cc: James Fookes <JFookes@morrisonhershfield.com>
Subject: Mixed-Use Development; 1050-1060 Bank Str.

Hi Glen

We are designing a mixed-use Development located at 1050-1060 Bank Street ([Link to Map location](#)). The proposed development consists of a six story mixed-use building, where floors 2-5 are residential, floor 1 is retail and the parking garage in the basement. Behind the building there are a few parking spaces located in a municipal laneway. Stormwater from the site will be directed into an existing storm sewer in Bank Street which outlets in Rideau River via Sunnyside Ave. (existing 1350 Conc. storm sewer on the south boundary of Leonard Ave.). I've attached an overview municipal storm sewers with the proposed site in red and the drainage route in orange. The current 0.16 ha site consists two areas, approx. 0.11ha of parking lot and 0.05 ha of existing commercial buildings. I've also attached a some preliminary design drawing to show the proposed development.

Please could you confirm whether on-site quality control is required for this site, and if required, what treatment level is required.

Kind Regards

Daniel Glauser

Municipal Designer - Infrastructure Ottawa

Office: 613 739 2910 Ext. 1022201

DGlauser@morrisonhershfield.com



Did You Know? Same smart people. Shiny new office

[200 – 2932 Baseline Road](#) | [Ottawa, ON K2H 1B1 Canada](#)

Dir: [613 739 2910](tel:6137392910) x1022201 | Fax: [613 739 4926](tel:6137394926)

morrisonhershfield.com

From: "Renaud, Jean-Charles" <Jean-Charles.Renaud@ottawa.ca>
Subject: 1050-1060 Bank Street - Preconsultation Followup
Date: October 24, 2018 at 10:35:11 AM EDT
To: "Bill Holzman" <b.holzman@holzmanconsultants.com>
Cc: "Bissonnette, Victoria" <victoria.bissonnette@ottawa.ca>, "Dubyk, Wally" <Wally.Dubyk@ottawa.ca>, "Richardson, Mark" <Mark.Richardson@ottawa.ca>, "Wessel, Shawn" <shawn.wessel@ottawa.ca>, "Moise, Christopher" <christopher.moise@ottawa.ca>, "cbrascoupe@rogers.com" <cbrascoupe@rogers.com>, "evanp@indevalco.com" <evanp@indevalco.com>, "Hamilton, Craig" <craig.hamilton@ottawa.ca>

Good morning Bill,

Further to our meeting on October 18, 2018, regarding the proposal to construct a new, 6-storey mixed-use building, please find attached the minutes from the meeting, as well as additional comments from various disciplines. The required studies and plans list is also attached.

Planning

- Please pay close attention to the proposed building's impact on the residential neighbourhood to the west, as they will be most impacted by the development. At the meeting, you had expressed a desire to meet the setback requirements in the zone in order to provide appropriate transition. Please keep in mind that, as building height is increased (in this case you are asking for roughly 5 metres above the zone requirement), so does the need for appropriate transition and respect of the neighbouring properties. Appropriate transition may result in going above and beyond the minimum required setbacks, given the request in added height.
- The amenity space requirements can be found in [Table 137\(6\)](#) of the Zoning Bylaw. It is unclear as to how functional the areas labeled "ext amenity" on the site plan will be. Please ensure that the minimum requirements are met, and that all amenity spaces are truly functional.
- Visitor Parking: It is understood that a parking reduction will

be sought at the Committee of Adjustment. Please provide the minimum number of required visitor parking spaces.

- Garbage location: As discussed at the meeting, the proposed location of the retail garbage enclosure is on a piece of land east of a City-owned laneway. By definition the landlocked 1060 Bank Street on which the garbage container is proposed to be is a separate property from 1060 Bank Street which abuts Bank and Euclid. Putting a garbage container on the landlocked property would require a rezoning to allow it as a main use on the lot. Furthermore the proposed retaining walls on the lane would be problematic, and would be an issue to be solved in discussions with the City Real Estate Group. It is suggested that the garbage enclosure be integrated within the main building.

- Please contact Victoria Bissonnette if you wish to discuss the merits of a Minor Variance application. A cursory review of the plans was made, however many of the dimensions were missing from the plans.

- The corner side yard setback along Aylmer Avenue for the portion above 15 metres does not appear to meet the 5-metre setback requirement.

- The rear yard setback for the portion below 15 metres does not appear to meet the 4.5-metre setback.

- Note that a variance would be required for reduced number of visitor parking spaces. Consider meeting this requirement and reducing the number of parking spaces for the residents.

- A variance may be required for a reduced communal amenity area.

- From looking at the renderings, it appears that variances may be required for the projections of the balconies that project into the corner side yards and potentially for the balconies on the 5th and 6th floor. Please show the extent to which the balconies project on the site plan

- The aisle in the parking garage shall be a minimum 6 metres.

Urban Design

- The massing and design approach appear to be respectful of the intent of the Traditional Main Street condition this proposal is situated in.
- We would like to better understand how the proposal relates to and mitigates the impact to the neighbouring residential properties to the west on Aylmer and Euclid avenues. A street elevation or massing model would show this.
- The west elevation hasn't been clearly illustrated, and this is perhaps the location of the biggest impact.
- The number and location and size of balconies between plan and perspective don't seem to align. (See attached Sketch A)
- Additional design description is required to better understand the exterior outdoor amenity spaces. (See attached Sketch B)
- You are welcome to visit the UDRP at any time prior to site plan application if you see fit to do so, but a formal visit to the UDRP will be required once an application is submitted.

Engineering

- The studies and plans list is attached.
- A Record of Site Condition is required for this site due to the proposed changes of use from commercial land use to a mixed land use intended for residential inhabitation and commercial operations. The requirement of a RSC does not depend on whether or not the site is clean and all documents are required to be prepared in accordance with the requirements of the MOECC regulations outlined for filing an RSC.
- Site is serviced by the following:
 - Aylmer
 - 203 mm diameter UCI WM
 - 300 mm diameter PVC sanitary sewer main discharging into Bank St. 300 mm diameter PVC sanitary sewer main.
 - 300 mm diameter PVC storm sewer main discharging into the Rideau River at Riverdale Ave from Bank St. Applicant is

required to contact RVCA to ensure no restrictions apply to their development. City of Ottawa will require all correspondence for our records.

- Bank St

- 305 mm diameter PVC WM
- 300 mm diameter PVC sanitary sewer main discharging to Rideau River Inceptor
- 375 mm diameter Conc. Storm sewer main discharging into the Rideau River at Riverdale Ave. Applicant is required to contact RVCA to ensure no restrictions apply to their development. City of Ottawa will require all correspondence for our records.

- Euclid Ave

- 152 mm diameter UCI WM
- 300 mm diameter PVC sanitary sewer main discharging into Bank St. 1200 mm diameter Brick Collector south of Grove Ave.
- 300 mm diameter Conc. storm sewer main discharging into the Rideau River at Leonard Ave. Applicant is required to contact RVCA to ensure no restrictions apply to their development. City of Ottawa will require all correspondence for our records.

- Excavation: Please note that a pre and post construction CCTV scan and report is required prior to approvals and if blasting is proposed - Constructability and Vibration Reports are required, including monitoring devices on all public infrastructure located within the ROW.

- Water Boundary conditions will be provided when requested

- SWM Criteria:

- Control post-development flow from the site to the 1:5 year predevelopment level for all storm events up to and including 1:100 year storm. Storage to be for 2 year storm events.
- Pre-development flow to be calculated using the smaller of a runoff coefficient of 0.5 or the actual existing runoff coefficient.
- Use either a Tc of 20 minutes or calculated the pre-development Tc but not less than 10 minutes
- Maximum ponding on the public and private roadways and

parking lot surfaces during 1:100 year storm event = 350mm max.
○ Please also see City of Ottawa Sewer & Water Design Guidelines, as amended, for more information.

Planning Forestry

- The proposal indicates street trees on a narrow right of way. To be successful the trees will require a large soil volume with appropriate drainage which will need to be a focus of the engineering for the site. If there is not room for trees, consider what the options are for the ends of the site where more significant trees are currently established (on Alymer and on Euclid).
- A Tree Conservation Report (TCR) must be supplied for review along with the suite of other plans/reports required by the City; an approved TCR is a requirement of Site Plan approval
- Any removal of privately-owned trees 10cm or larger in diameter requires a tree permit issued under the Urban Tree Conservation Bylaw; the permit is based on the approved TCR
- The removal of City-owned trees will require the permission of Forestry Services who will also review the submitted TCR
- In this case, the TCR may be combined with the Landscape Plan.
- The TCR must list all trees on site by species, diameter and health condition – separate stands of trees may be combined using averages
- The TCR must address all trees with a critical root zone that extends into the developable area – all trees that could be impacted by the construction that are outside the developable area need to be addressed.
- Trees with a trunk that crosses/touches a property line are considered co-owned by both property owners; permission from the adjoining property owner must be obtained prior to the removal of co-owned trees
- If trees are to be removed, the TCR must clearly show where

they are, and document the reason they cannot be retained – please provide a plan showing retained and removed treed areas

- All retained trees must be shown and all retained trees within the area impacted by the development process must be protected as per City guidelines listed on Ottawa.ca
- The City encourages the retention of healthy trees; if possible, please seek opportunities for retention of trees that will contribute to the design/function of the site.
- For more information on the process or help with tree retention options, contact Mark Richardson mark.richardson@ottawa.ca

Transportation

- Bank Street is designated as an Arterial road within the City's Official Plan with a ROW protection limit of 23.0 metres. The ROW protection limit and the offset distance (11.5 metres) are to be dimensioned from the existing centerline of pavement and shown on the drawings.
- ROW interpretation – Land for a road widening will be taken equally from both sides of a road, measured from the centreline in existence at the time of the widening if required by the City. The centreline is a line running down the middle of a road surface, equidistant from both edges of the pavement. In determining the centreline, paved shoulders, bus lay-bys, auxiliary lanes, turning lanes and other special circumstances are not included in the road surface.

Applications Required / Next Steps

- [Site Plan Control](#), manager approval, with public consultation
- Committee of Adjustment application for [Minor Variance](#).
- Please note that these pre-consultation comments are valid for one year. If you submit a development application after this time, you may be required to meet for another pre-consultation meeting and/or the submission requirements may change.

- Prior to making a complete submission, I also encourage you to discuss the proposal with the area Councillor, David Chernushenko, Councillor elect Shawn Menard, local community associations as well as immediate neighbours.

I trust this information is helpful. Please do not hesitate to contact me if you have questions or require clarification.

JC

Jean-Charles Renaud, MCIP/MICU, RPP/UPC

Planner II | *Urbaniste II*

Development Review, Central | *Examen des projets d'aménagement, Central Planning, Infrastructure and Economic Development Department | Services de la planification, de l'infrastructure et du développement économique*

City of Ottawa | *Ville d'Ottawa*

110 Laurier Avenue West. Ottawa, ON | *110, avenue. Laurier Ouest. Ottawa (Ontario) K1P 1J1*

613.580.2424 ext./poste 27629

ottawa.ca/planning / ottawa.ca/urbanisme

Appendix C

Water Demand and FUS Calculations

1050 + 1060 Bank Street Water Demand Calculations

Fire Flow

Project Name Site Servicing 1050+1060 Bank Street
Project Number 190500700
Site Address 1050+1060 Bank Street
Completed By DG
Date 24-Sep-20

(Per Fire Underwriters Survey, Water Supply for Public Fire Protection, 1999)

1. Determine Estimated Fire Flow based on Building Floor Area

$$F = 220 C \sqrt{A}$$

F = Required flow in litres / minute

A = Total floor area in m²

C = Coefficient related to Construction
 = 1.5 for wood frame construction
 = 1.0 for ordinary construction
 = 0.8 for non-combustible construction
 = 0.6 for fire-resistive construction

C =	0.8
A =	4848 m ²

$$F = 12254.5 \text{ L/min}$$

Round to nearest 1000 L/m, F = 12000.0 L/min

2. Adjust flow based on Fire hazard and contents

A	Non-combustible	-25%
B	Limited Combustible	-15%
C	Combustible	0%
D	Free Burning	15%
E	Rapid Burning	25%

Type of Construction (A,B,C,D)	C
Adjustment Factor	0%
Flow From 1.	12000.0 L/min
Adjusted Flow	12000.0 L/min
Minimum Flow (2000 L/min)	12000.0 L/min
Flow	12000.0 L/min

3. Reduce flow from No. 2. based on automatic sprinkler protection

Flow from 2.	12000.0 L/min
Complete Automatic Sprinkler Protection (yes/no)	Yes
Reduction	30%
Sprinkler system is standard for fire department hose lines (yes/no)	Yes
Additional Reduction	10%
Sprinkler System is fully supervised (yes/no)	no
Additional Reduction	0%
Total Reduction	40%
Flow after Sprinkler Reduction	7200.0 L/min

4. Adjacent Structures / Fire Separation with other buildings

Flow from 3.	7200.0 L/min
A 0m-3m	25%
B 3.1m - 10m	20%
C 10.1m to 20m	15%
D 20.1m to 30m	10%
E 30.1 m to 45m	5%
F 45m +	0%

	Distance to Adjacent Building	Flow Increase	Distance
North	E	5%	32
East	D	10%	23
South	C	15%	13
West	B	20%	4

Cumulative Increase (Max 75%) 50%

Flow Increased for Adjacent Structures	10800.0 L/min
Fire flow rounded to nearest 1000 L/min	11000.0 L/min
Maximum Permitted Flow (45 000 L/min)	11000.0 L/min
Minimum Permitted Flow (2 000 L/min)	11000.0 L/min

Fire Flow 11000.0 L/min
183.3 L/s

1050 + 1060 Bank Street Water Demand Calculations

24-Sep-20

Key Plan showing surrounding hydrants and distances to surrounding structures



1050 + 1060 Bank Street Water Demand Calculations

24-Sep-20

Domestic Water Demands

Project Name Site Servicing 1050+1060 Bank Street
Project Number 190500700
Site Address 1050+1060 Bank Street
Completed By DG

Building Occupancy 84 people
 Total Gross Building Area (Retail) 826 m²

Building Occupancy Breakdown

Unit type		persons per unit	
Bachelor/Studio	6 ea	1.4	8.4
1 Bedroom	18 ea	1.4	25.2
2 Bedroom	12 ea	2.1	25.2
3 Bedroom	8 ea	3.1	24.8
		Total	83.6
Retail	826.0 m ²		

Residential 84 persons
 Per Capita Flow 350 l/per/d City of Ottawa Water Design Guidelines Table 4.2 - residential
 Daily average flow 29400 l/d
 Daily average flow 0.340 l/s

Commercial (Water Demand) 2500 L/(1000m²/d) City of Ottawa Water Design Guidelines Table 4.2 - Shopping Center
 Daily average flow 2065 l/d
 Daily average flow 0.024 l/s

Total Average Daily Demand 0.364 L/day 21.85069

Residential portion
Maximum Daily Demand Peak
 Peak Factor 7.43 x average day MOE Design Guidelines for Drinking-Water System, Table 3-3
 Peak Flow 2.53 l/s
 40.07 GPM

Maximum Hourly Demand Peak
 Peak Factor 11.20 x average day MOE Design Guidelines for Drinking-Water System, Table 3-3
 Peak Flow 3.81 l/s
 60.38 GPM

Retail portion
Maximum Daily Demand Peak
 Peak Factor 1.50 x average day City of Ottawa Water Design Guidelines, Table 4.2 - Shopping Center
 Peak Flow 0.036 l/s
 0.57 GPM

Maximum Hourly Demand Peak
 Peak Factor 1.80 x max day City of Ottawa Water Design Guidelines, Table 4.2 - Shopping Center
 Peak Flow 0.065 l/s
 1.02 GPM

Total Max Daily water demand 2.56 l/s
Total Max Hourly water demand 3.87 l/s

Fire Flow (refer to separate calculation) 183.33 l/s
Max Daily + Fire demand 185.90 l/s

1050 + 1060 Bank Street Water Demand Calculations

Domestic Water Peaking Factors

Project Name Site Servicing 1050+1060 Bank Street
Project Number 190500700
Site Address 1050+1060 Bank Street
Completed By DG
Date 9/24/2020

Excerpt from the MOE Design Guidelines for Drinking-Water System, Table 3-3

Dwelling Units Served	Equivalent Population	Night Minimum Hour Demand	Maximum Daily Factor	Peak Hour Factor
10	30	0.1	9.5	14.3
50	150	0.1	4.9	7.4
100	300	0.2	3.6	5.4
150	450	0.3	3	4.5
167	500	0.4	2.9	4.3

MAXIMUM DAILY DEMAND	
Actual Population	Corresponding Factor (Interpolated)
84	7.43

MAXIMUM HOURLY DEMAND	
Actual Population	Corresponding Factor (Interpolated)
84	11.20

1050 + 1060 Bank Street Water Demand Calculations

Water Service Sizing (Max Day + Fire)

24-Sep-20

HGL_{Road}= 104.00 (m)
 Building FFE= 71.56 (m)
 P_{Road}= 32.44 (m)
 P_{Road}= 318.2 (kPa)
 P_{Road}= 46.16 (psi)

Length

L= 15 (m)
 49 (ft)

Size

d= 200 (mm)
 8 (in)

Flow

Q = 0.1859 (m³/s)
 2947 (Usg/min)

Velocity

$$V = \frac{1.274Q}{d^2}$$

V= 5.92 (m/s)

Head Loss

$$P_d = \frac{4.52Q^{1.85}}{C^{1.85}d^{4.87}}$$

$$P = 0.434hSG$$

SG= specific gravity of water
 = 1
 C = 110
 P_d= 0.0856 (psi)
 h= 0.197 (ft/ft)
 9.70 (ft)

Pipe Diameter	C-Factor
150	100
200-250	110
300-600	120
600+	130

Pressure Loss

P_{ROAD}= 46.2 (psi)
 P_L= 4.2 (psi)
 P_{AT METER}= 41.9 (psi)
 P_{AT METER}= 289.2 (kPa)

Minimum pressure required under Maximum Day + Fire Demand = 140.0 (kpa)

Pressure is satisfactory

1050 + 1060 Bank Street Water Demand Calculations

Water Service Sizing (Max Hourly)

24-Sep-20

HGL_{Road}= 104.30 (m)
 Building FFE= 71.56 (m)
 P_{Road}= 32.74 (m)
 P_{Road}= 321.2 (kPa)
 P_{Road}= 46.58 (psi)

Length

L= 15 (m)
 49 (ft)

Size

d= 200 (mm)
 8 (in)

Flow

Q = 0.0039 (m³/s)
 61 (Usg/min)

Velocity

$$V = \frac{1.274Q}{d^2}$$

V= 0.12 (m/s)

Head Loss

$$P_d = \frac{4.52Q^{1.85}}{C^{1.85}d^{4.87}}$$

$$P = 0.434hSG$$

SG= specific gravity of water
 = 1
 C = 110

P_d= 0.000066 (psi)
 h= 0.000153 (ft/ft)
 0.0075 (ft)

Pipe Diameter	C-Factor
150	100
200-250	110
300-600	120
600+	130

Pressure Loss

P_{ROAD}= 46.6 (psi)
 P_L= 0.0 (psi)
 P_{AT METER}= 46.6 (psi)
 P_{AT METER}= 321.1 (kPa)

Minimum pressure required under Maximum Hourly Demand = 276.0 (kPa)

Pressure is satisfactory

Requirement for Domestic Water Booster Pump

Roof elevatipn= 90.91 (m)
 Building height= 19.35 (m)
 Max height at which minimum pressure is provided= 4.6 (m) above ground floor

Booster pump is required for all floors >4.6m above ground floor

Daniel Glauser

From: Maurizio Martignago <mmartignago@kwc-arch.ca>
Sent: Thursday, September 19, 2019 2:21 PM
To: Daniel Glauser
Cc: James Fookes
Subject: RE: Bank and Aylmer questions for Maurizio

Hi Daniel.
Not expecting any hazardous materials.

We are going to fall under OBC 3.2.2.43 Group C, Up to 6 Storeys, **Sprinklered**, Noncombustible Construction.

Thanks.

Maurizio Martignago B.Arch, OAA, MRAIC, *LEED AP*
Partner / Principal

KWC Architects Inc.

383 Parkdale Avenue Suite 201, Ottawa, Ontario K1Y 4R4
T: 613-238-2117 ext. 230 F: 613-238-6595 E: mmartignago@kwc-arch.com

From: Daniel Glauser <DGlauser@morrisonhershfield.com>
Sent: September-19-19 12:27 PM
To: Maurizio Martignago <mmartignago@kwc-arch.ca>
Cc: James Fookes <JFookes@morrisonhershfield.com>
Subject: RE: Bank and Aylmer questions for Maurizio

Hi Maurizio,

Thanks for the info, this should help define out water/fire flow and stormwater storage.

“Can you confirm the building isn’t expected to house any combustible material. KWC – no combustible material however can you give an example your thinking of.”

The FUS has a loose definition that covers a broad range of “High Hazard Occupancies”. Generally it refers to manufacturing or chemical applications, however they do refer to paint and varnish as being high hazard.

If we can say that the retail portion of the shops are predicted to be restaurants or clothing shops then we can reduce the required flow by up to 25%. I’ve attached the appendix below. I think it’s safe to assume that there won’t be any hazardous material in these areas.

Examples of High Hazard Occupancies:

Aircraft Hangars	Pyrotechnics Manufacturing Shade
Cereal, Feed, Flour and	Cloth Manufacturing
Grist Mills Chemical Works -	Foamed Plastics, Storage or
High Hazard	use in Manufacturing
Cotton Picker and Opening	High Piled Combustibles
Operations Explosives &	Storage in excess of 6.5
	metres high
Linseed Oil Mills	
Match Manufacturing	
Oil Refineries	
Paint Shops	
Pyroxylin Plastic Manufacturing & Processing Solvent Extracting	
Varnish and Paint Works	
Woodworking with Flammable Finishing Linoleum and Oilcloth	
Manufacturing	

Other occupancies involving processing, mixing storage and dispensing flammable and/or combustible liquids. Generally, occupancies falling in National Building Code Group F, Divisions 1 and 2 would be in this class.

For other occupancies, good judgement should be used, and the percentage increase will not necessarily be the same for all buildings that are in the same general category - for example "Colleges and Universities": this could range from a 25% decrease for buildings used only as dormitories to an increase for a chemical laboratory. Even when considering high schools, the decrease should be less if they have extensive shops.

It is expected that in commercial buildings no percentage increase or decrease for occupancy will be applied in most of the fire flow determinations. In general, percentage increase or decrease will not be at the limits of plus or minus 25%.

Kind Regards

Daniel Glauser

Municipal Designer - Infrastructure Ottawa

Office: 613 739 2910 Ext. 1022201

DGlauser@morrisonhershfield.com



Did You Know? Same smart people. Shiny new office
[200 – 2932 Baseline Road | Ottawa, ON K2H 1B1 Canada](#)
Dir: [613 739 2910](tel:6137392910) x1022201 | Fax: [613 739 4926](tel:6137394926)
morrisonhershfield.com

From: Maurizio Martignago [<mailto:mmartignago@kwc-arch.ca>]
Sent: Thursday, September 19, 2019 12:06 PM
To: Daniel Glauser <DGlauser@morrisonhershfield.com>
Cc: James Fookes <JFookes@morrisonhershfield.com>
Subject: RE: Bank and Aylmer questions for Maurizio

Hi Daniel,
See below, responses in red.

Ground Floor: 10401sqft
2nd Floor: 11053 sqft
3rd Floor: 11053 sqft

4th Floor: 11053 sqft
5th Floor: 6487 sqft
6th Floor: 4802 sqft

Maurizio Martignago B.Arch, OAA, MRAIC, LEED AP
Partner / Principal

KWC Architects Inc.

383 Parkdale Avenue Suite 201, Ottawa, Ontario K1Y 4R4
T: 613-238-2117 ext. 230 F: 613-238-6595 E: mmartignago@kwc-arch.com

From: Daniel Glauser <DGlauser@morrisonhershfield.com>
Sent: September-18-19 9:43 AM
To: Maurizio Martignago <mmartignago@kwc-arch.ca>
Subject: Bank and Aylmer questions for Maurizio

Hi Maurizio

I've made some of the following assumptions for the water demand/fire flow and stormwater management:

1. Can you confirm the amount of expected apartments of the following type (based on estimates in preliminary design drawings), **KWC -This is correct**

Apartments:	Number
Bach/Studio	6
1 Bedroom	18
2 Bedroom	13
3 Bedroom	7

2. Can you confirm the square meterage of the building excluding the basement is approximately 4350m² or 47100ft²
3. Can you confirm the what type of construction the proposed building is (wood frame construction (structure essentially all combustible), ordinary (brick or other masonry walls, combustible floor and interior), non-combustible (unprotected metal structural components, masonry or metal walls) or fire-resistive (fully protected frame, floors, roof)). **KWC – the building will be concrete frame, non combustible construction (no wood framing is anticipated).**
4. Can you confirm the building isn't expected to house any combustible material. **KWC – no combustible material however can you give an example your thinking of.**
5. Can you confirm that an automatic sprinkler system with a standard siamese connection is proposed for the new building. Additionally will the system be fully supervised? **KWC – will get back to you on this one.**
6. Is it safe to assume maximum 150mm stormwater pooling on the roof above the 5th floor? If so what area can we assume for storage? **KWC – we can assume roof storage for now. This will become a question for the structural engineer when they come on board.**

We are just following up with Shawn from the city regarding the pre-consultation notes he had.

Kind Regards

Daniel Glauser
Municipal Designer - Infrastructure Ottawa

James Fookes

From: Wessel, Shawn <shawn.wessel@ottawa.ca>
Sent: May 13, 2020 3:01 PM
To: Daniel Glauser; Renaud, Jean-Charles
Cc: Maurizio Martignago; James Fookes
Subject: RE: 1050+1060 Bank Street; Boundary Conditions for Water Demand

Good afternoon Mr. Glauser.

I have checked with Water Distribution and they have stated that pressures remain the same for this site.

If you require additional information or clarification, please do not hesitate to contact me anytime.

Thank you

Regards,

Shawn Wessel, A.Sc.T.,rcji
Project Manager - Infrastructure Approvals
Gestionnaire de projet – Approbation des demandes d’infrastructures

Development Review Central Branch | Direction de l’examen des projets d’aménagement, Centrale
Planning, Infrastructure and Economic Development Department | Direction générale de la planification
de l’infrastructure et du développement économique
City of Ottawa | Ville d’Ottawa
110 Laurier Ave. W. | 110, avenue Laurier Ouest, Ottawa ON K1P 1J1
(613) 580 2424 Ext. | Poste 33017
Int. Mail Code | Code de Courrier Interne 01-14
shawn.wessel@ottawa.ca

 Please consider the environment before printing this email

*****Please note that, while my work hours may be affected by the current situation, I still have access to email, video conferencing and telephone. Feel free to schedule video conferences and/or telephone calls, as necessary.*****

From: Daniel Glauser <DGlauser@morrisonhershfield.com>
Sent: May 13, 2020 2:31 PM
To: Wessel, Shawn <shawn.wessel@ottawa.ca>; Renaud, Jean-Charles <Jean-Charles.Renaud@ottawa.ca>
Cc: Maurizio Martignago <mmartignago@kwc-arch.ca>; James Fookes <JFookes@morrisonhershfield.com>
Subject: RE: 1050+1060 Bank Street; Boundary Conditions for Water Demand

CAUTION: This email originated from an External Sender. Please do not click links or open attachments unless you recognize the source.

ATTENTION : Ce courriel provient d'un expéditeur externe. Ne cliquez sur aucun lien et n'ouvrez pas de pièce jointe, excepté si vous connaissez l'expéditeur.

Hi Shawn,

Thanks for the boundary conditions analysis. I was hoping that you could confirm that the pressure's haven't changed when comparing to our first submission?

I've attached the original boundary conditions e-mail for reference.

Thanks in advance.

Kind Regards

Daniel Glauser

Municipal Designer - Infrastructure Ottawa

Office: 613 739 2910 Ext. 1022323

DGlauser@morrisonhershfield.com



Did You Know? Same smart people. Shiny new office

[200 – 2932 Baseline Road | Ottawa, ON K2H 1B1 Canada](#)

Dir: [613 739 2910](tel:6137392910) x1022323 | Fax: [613 739 4926](tel:6137394926)

morrisonhershfield.com

From: Wessel, Shawn [<mailto:shawn.wessel@ottawa.ca>]

Sent: Monday, May 11, 2020 9:50 AM

To: Daniel Glauser <DGlauser@morrisonhershfield.com>; Renaud, Jean-Charles <Jean-Charles.Renaud@ottawa.ca>

Cc: Maurizio Martignago <mmartignago@kwc-arch.ca>; James Fookes <JFookes@morrisonhershfield.com>

Subject: RE: 1050+1060 Bank Street; Boundary Conditions for Water Demand

Good morning Mr. Glauser.

Please find requested conditions below:

The following are boundary conditions, HGL, for hydraulic analysis at 1050-1060 Bank (zone 1W) assumed to be connected to the 305mm on Bank (see attached PDF for location).

Minimum HGL = 104.3m

Maximum HGL = 114.7m

MaxDay + FireFlow (183 L/s) = 104.0m

These are for current conditions and are based on computer model simulation.

Disclaimer: The boundary condition information is based on current operation of the city water distribution system. The computer model simulation is based on the best information available at the time. The operation of the water distribution system can change on a regular basis, resulting in a variation in boundary conditions.

The physical properties of watermains deteriorate over time, as such must be assumed in the absence of actual field test data. The variation in physical watermain properties can therefore alter the results of the computer model simulation.

If you require additional information or clarification, please do not hesitate to contact me anytime.

Thank you

Regards,

Shawn Wessel, A.Sc.T.,rcji
Project Manager - Infrastructure Approvals
Gestionnaire de projet – Approbation des demandes d’infrastructures

Development Review Central Branch | Direction de l’examen des projets d’aménagement, Centrale
Planning, Infrastructure and Economic Development Department | Direction générale de la planification
de l’infrastructure et du développement économique
City of Ottawa | Ville d’Ottawa
110 Laurier Ave. W. | 110, avenue Laurier Ouest, Ottawa ON K1P 1J1
(613) 580 2424 Ext. | Poste 33017
Int. Mail Code | Code de Courrier Interne 01-14
shawn.wessel@ottawa.ca

 Please consider the environment before printing this email

*****Please note that, while my work hours may be affected by the current situation, I still have access to email, video conferencing and telephone. Feel free to schedule video conferences and/or telephone calls, as necessary.*****

From: Wessel, Shawn
Sent: May 07, 2020 12:21 PM
To: Daniel Gluser <DGlauser@morrisonhershfield.com>; Renaud, Jean-Charles <Jean-Charles.Renaud@ottawa.ca>
Cc: Maurizio Martignago <mmartignago@kwc-arch.ca>; James Fookes <JFookes@morrisonhershfield.com>
Subject: RE: 1050+1060 Bank Street; Boundary Conditions for Water Demand

Good afternoon Mr. Gluser and thank you for your email and request.

I have forwarded your email on to our Water Distribution Dept. for conditions and will provide response when received.

If you require additional information or clarification, please do not hesitate to contact me anytime.

Thank you

Regards,

Shawn Wessel, A.Sc.T.,rcji
Project Manager - Infrastructure Approvals
Gestionnaire de projet – Approbation des demandes d’infrastructures

Development Review Central Branch | Direction de l’examen des projets d’aménagement, Centrale
Planning, Infrastructure and Economic Development Department | Direction générale de la planification
de l’infrastructure et du développement économique
City of Ottawa | Ville d’Ottawa
110 Laurier Ave. W. | 110, avenue Laurier Ouest, Ottawa ON K1P 1J1
(613) 580 2424 Ext. | Poste 33017
Int. Mail Code | Code de Courrier Interne 01-14
shawn.wessel@ottawa.ca

 Please consider the environment before printing this email

*****Please note that, while my work hours may be affected by the current situation, I still have access to email, video conferencing and telephone. Feel free to schedule video conferences and/or telephone calls, as necessary.*****

From: Daniel Glauser <DGlauser@morrisonhershfield.com>
Sent: May 07, 2020 11:54 AM
To: Renaud, Jean-Charles <Jean-Charles.Renaud@ottawa.ca>
Cc: Wessel, Shawn <shawn.wessel@ottawa.ca>; Maurizio Martignago <mmartignago@kwc-arch.ca>; James Fookes <JFookes@morrisonhershfield.com>
Subject: FW: 1050+1060 Bank Street; Boundary Conditions for Water Demand

CAUTION: This email originated from an External Sender. Please do not click links or open attachments unless you recognize the source.

ATTENTION : Ce courriel provient d’un expéditeur externe. Ne cliquez sur aucun lien et n’ouvrez pas de pièce jointe, excepté si vous connaissez l’expéditeur.

Hi Jean-Charles, Shawn,

Based on the comments regarding the fire flow reduction based on occupancy type, I’ve revised the required fire flow. Also the occupancy and floor area has changed (<1%, nevertheless I adjusted the calculations).

The following table outlines the relevant design parameters/criteria and the corresponding calculated values (The revised calculations will be disclosed in the revised site servicing brief):

Design Parameter	Value (L/s)	Design Criteria
Residential Average Daily Demand	0.36	350 L/d/P ¹
Residential Maximum Daily Demand	2.53	7.5 x Average Daily ²
Residential Maximum Hourly Demand	3.81	11.25 x Average Daily ²
Retail/Commercial Average Daily Demand	0.024	2500 L/(1000m ² /d)
Retail/Commercial Maximum Daily Demand	0.036	1.5 x Average Daily ³

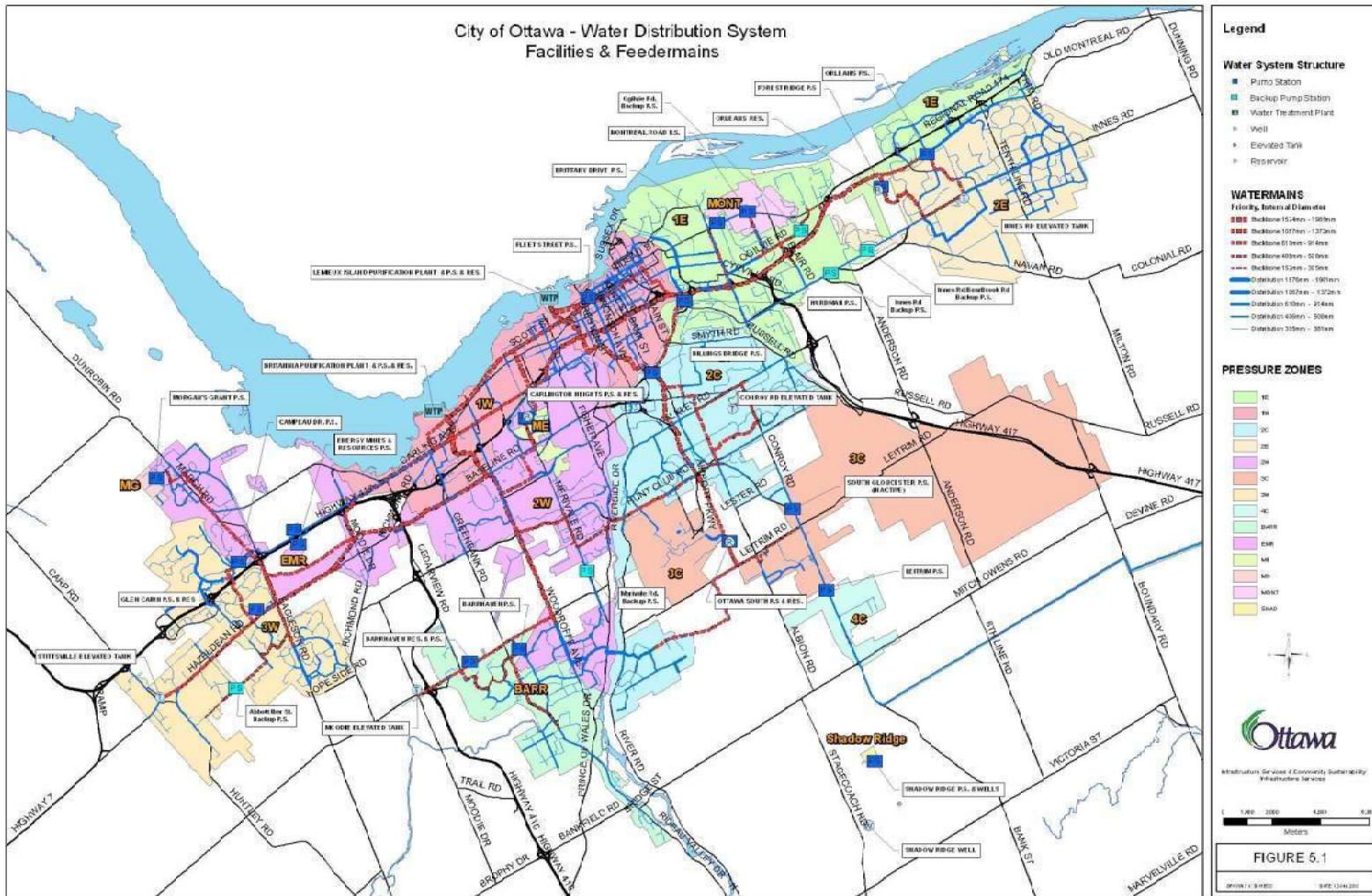

Source: City of Ottawa GIS infrastructure database

Figure 5.1: City of Ottawa Water Distribution System, Facilities and Feeder mains

Appendix D

Sanitary Flow Calculations

1050 +1060 Bank Street Sanitary Flow Estimate

Residential

Occupancy	84	persons	(Refer to Domestic Water Demand Calculations)
Per Capita Flow	280	l/c.d	(Sewer Design Guidelines, Figure 4.3)
Daily average flow	23 520	l/d	
	23.52	m ³ /d	
Peak Factor	3.6		(Sewer Design Guidelines, Figure 4.3; Harmon Equation)
Peak Flow	0.98	l/s	

$$P.F. = 1 + \left(\frac{14}{4 + \left(\frac{P}{1000} \right)^{\frac{1}{2}}} \right) * K$$

Commercial

Gross Area	0.16	ha
Commercial Average Flow	28 000	L/ha/d
Peaking Factor	1.5	
Daily average flow	4 480	l/d
Peak Flow	6 720	L/day
	0.08	L/s

Infiltration

Site Area	0.16	ha
Infiltration allowance	0.33	l/s.gross ha
Infiltration flow	0.0528	l/s

Resulting total flow	1.11	L/s
----------------------	------	-----

Designed: D. Glauser		Project: Proposed Development 1050+1060 Bank Street	
Checked: J. Fookes		Location: 1050+1060 Bank Street	
Date: September 24, 2020			
Dwg Reference: C-001	File Ref: 190500700	Sheet No.:	1 of 1

1050 + 1060 Bank Street Sanitary Catchments

The figure below displays the assumed catchment areas. This is meant to clarify the calculations found in the "EXISTING SANITARY SEWER CALCULATION SHEET"

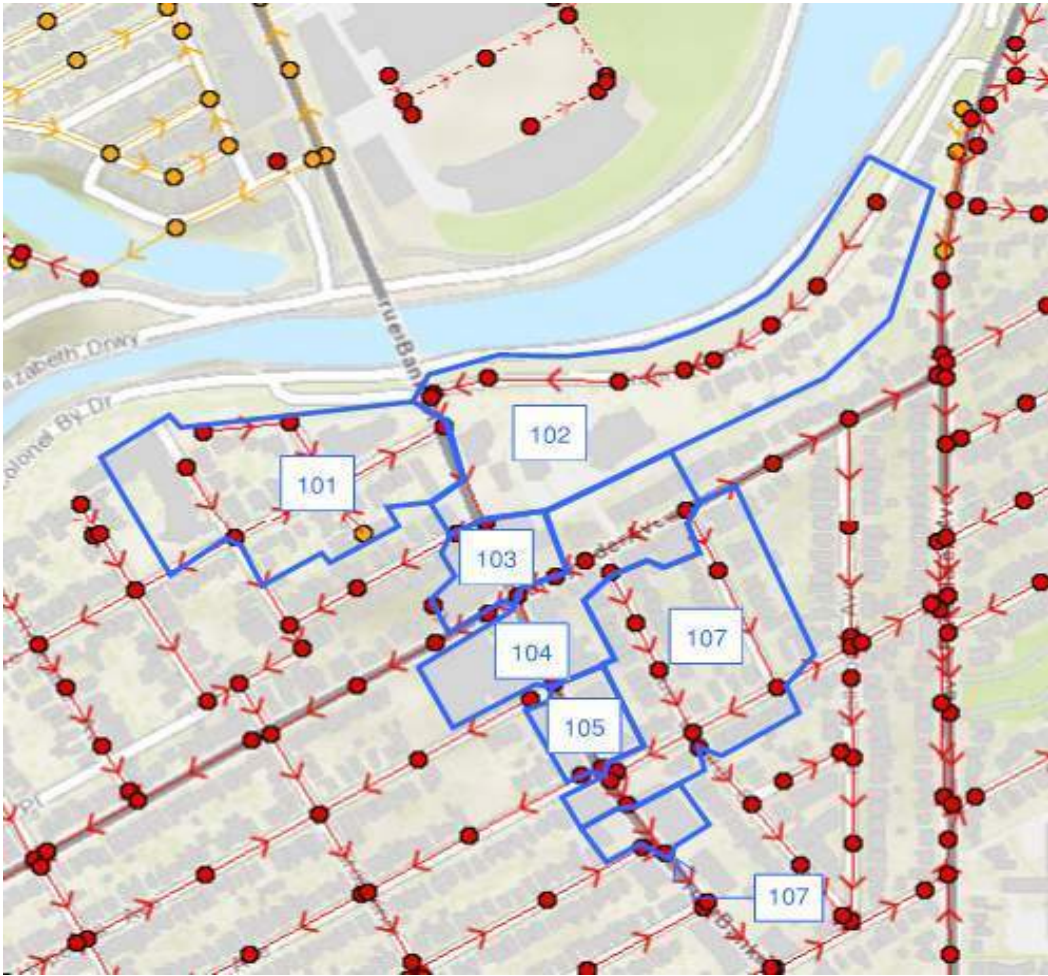

Appendix E

Storm Sewer Design Calculations

1. Existing Conditions & Release Rate

Proposed Development - 1050-1060 Bank Str.

Project No.	190500700
Date	Nov 25, 2019
Prepared By:	D Glauser
Checked By	J Fookes

Existing Drainage Area Characteristics

Drainage Area	Area, A (ha)	Runoff Coefficient, R
EBLDG1	0.031	0.90
EBLDG2	0.016	0.90
PL1	0.111	0.90
EST1	0.0014	0.90
Total	0.159	0.90

Asphalt Area:	R = 0.90
Grassy Area:	R = 0.30
Building Area:	R = 0.90
Gravel Area:	R = 0.50
Concrete Area:	R = 0.90

Existing Conditions

Q = RAIN where Q = runoff rate (L/s)

R = runoff coefficient
i = rainfall intensity (mm/hr)
A = drainage area (ha)
N = 2.78

and
$$i = \frac{A}{(T_d + C)^B}$$

T_d = Time of Concentration = 10 (min)

Return Period (Years)	A	B	C	Intensity, I (mm/hr)	Area (ha)	Runoff Coefficient, R (Note 1)	Runoff Rate, Q (L/s)
5	998.071	0.814	6.053	104.2	0.159	0.90	41.6
100	1735.688	0.82	6.014	178.6	0.159	1.00	79.1

Note 1: For 100-year event, Runoff Coefficient is increased by 25% to a maximum of 1.0.

Allowable Release Rate

Criteria for calculation of allowable release rate:

Return Period 5 year
Maximum Runoff Coefficient 0.5
Time of Concentration 10 minutes

Return Period (Years)	A	B	C	Intensity, I (mm/hr)	Area (ha)	Runoff Coefficient, R	Runoff Rate, Q (L/s)
5	998.071	0.814	6.053	104.2	0.159	0.50	23.1

Allowable release rate from site in 100-year storm is 23.1 L/s

2. Proposed Uncontrolled Flow

Proposed Development - 1050-1060 Bank Str.

Project No.	190500700
Date	Nov 25, 2019
Prepared By:	D Glauser
Checked By	J Fookes

Proposed Uncontrolled Drainage Area Characteristics

Drainage Area	Area, A (ha)	Runoff Coefficient, R (5-year event)	Runoff Coefficient, R (100-year event, Note 1)
RAMP	0.013	0.90	1.00
SB1	0.028	0.90	1.00
SB3	0.0006	0.90	1.00
Total	0.042	0.90	1.00

(Refer to Proposed Storm Drainage Area Plan)

Note 1: For 100-year event, Runoff Coefficient is increased by 25% to a maximum of 1.0.

Runoff coefficients used in calculations:

Asphalt Area:	R = 0.90
Grassy Area:	R = 0.30
Building Area:	R = 0.90
Gravel Area:	R = 0.50
Concrete Area:	R = 0.90

Proposed Uncontrolled Runoff

Q = RAIN where Q = runoff rate (L/s)

R = runoff coefficient
i = rainfall intensity (mm/hr)
A = drainage area (ha)
N = 2.78

and
$$i = \frac{A}{(T_d + C)^B}$$

T_d = Time of Concentration = 10 (min)

Return Period (Years)	A	B	C	Intensity, I (mm/hr)	Area (ha)	Runoff Coefficient, R	Runoff Rate, Q (L/s)
5	998.071	0.814	6.053	104.2	0.042	0.90	10.8
100	1735.688	0.82	6.014	178.6	0.042	1.00	20.7

Remaining Allowable Release Rate

Total Allowable Release Rate 23.1 (L/s)
Uncontrolled Runoff (100 year) 20.7 (L/s)
Remaining Allowable Release Rate 2.4 (L/s)

Runoff from remaining drainage areas in 100-year event will be controlled to 2.4 L/s

3. Proposed Storage

Proposed Development - 1050-1060 Bank Str.

Project No.	190500700
Date	Nov 25, 2019
Prepared By:	D Glauser
Checked By	J Fookes

Proposed Controlled Drainage Area Characteristics

Drainage Area	Area, A (ha)	Runoff Coefficient, R (5-year event)	Runoff Coefficient, R (100-year event, Note 1)
BLDG1	0.05	0.90	1.00
BLDG2	0.04	0.90	1.00
SB2	0.002	0.90	1.00
SB4	0.02	0.86	1.00
Total	0.112	0.89	1.00

(Refer to Proposed Storm Drainage Area Plan)

Note 1: For 100-year event, Runoff Coefficient is increased by 25% to a maximum of 1.0.

Allowable Release Rate from storage (100-year event) = 2.4 (L/s)
 Average release rate for calculation of storage volume = 1.2 (L/s) (Conservatively estimated as 50% of allowable release rate)

Orifice Sizing

$$Q = CA(2gH)^{0.5}$$

C = 0.61
 Design Flow Rate = 2.4 (L/s)
 Proposed 100-year tank depth = 1.33 (m)
 Orifice Area = 766 (mm²)
 Orifice diameter = 31 (mm) (if <75mm then vortex ICD required)

Release Rates during 5-year event

Water depth during 5-year event = 0.270 (m) (based on result of Req. Storage Vol. calc below)
 Maximum release rate during 5-year event = 1.2 (L/s) (based on orifice size, see attached data sheet)
 Average release rate during 5-year event = 0.7 (L/s) (Refer to attached calculation sheet)

Required Storage Volume (using Modified Rational Method)

Q = RAIN

Q = runoff rate (L/s) $i = \frac{A}{(T_d + C)^B}$ where i = Rainfall Intensity (mm/hr)
 R = runoff coefficient $T_d =$ Time of Concentration (min)
 i = rainfall intensity (mm/hr)
 A = drainage area (ha)
 N = 2.78

Time, Td (min)	5-Year Event				100-Year Event			
	Intensity (mm/hr)	Peak Flow (L/s)	Average Release Rate (L/s)	Storage Volume (m ³)	Intensity (mm/hr)	Peak Flow (L/s)	Average Release Rate (L/s)	Storage Volume (m ³)
10	104.19	29.0	0.65	17.0	178.56	49.6	1.19	29.1
15	83.56	23.2	0.65	20.3	142.89	39.7	1.19	34.7
20	70.25	19.5	0.65	22.7	119.95	33.3	1.19	38.6
25	60.90	16.9	0.65	24.4	103.85	28.9	1.19	41.5
30	53.93	15.0	0.65	25.8	91.87	25.5	1.19	43.8
40	44.18	12.3	0.65	27.9	75.15	20.9	1.19	47.3
50	37.65	10.5	0.65	29.4	63.95	17.8	1.19	49.8
60	32.94	9.2	0.65	30.6	55.89	15.5	1.19	51.6
80	26.56	7.4	0.65	32.3	44.99	12.5	1.19	54.3
100	22.41	6.2	0.65	33.5	37.90	10.5	1.19	56.1
120	19.47	5.4	0.65	34.3	32.89	9.1	1.19	57.3
140	17.27	4.8	0.65	34.8	29.15	8.1	1.19	58.1
160	15.56	4.3	0.65	35.2	26.24	7.3	1.19	58.6
180	14.18	3.9	0.65	35.5	23.90	6.6	1.19	58.9
200	13.05	3.6	0.65	35.7	21.98	6.1	1.19	59.0
220	12.10	3.4	0.65	35.8	20.37	5.7	1.19	59.0
240	11.29	3.1	0.65	35.8	19.01	5.3	1.19	58.9
260	10.60	2.9	0.65	35.8	17.83	5.0	1.19	58.7

280	9.99	2.8	0.65	35.7	16.80	4.7	1.19	58.4
300	9.46	2.6	0.65	35.6	15.89	4.4	1.19	58.1
320	8.98	2.5	0.65	35.4	15.09	4.2	1.19	57.6
340	8.56	2.4	0.65	35.2	14.37	4.0	1.19	57.2

minimum time = time of concentration

Storage volume used	35.8 m ³	Storage volume used	59.0 m ³
---------------------	---------------------	---------------------	---------------------

A storage tank with a minimum volume of 59 m³ is required.

Incremental draindown calculation (5-year event):

Water depth at start of step, h1 (m)	Water depth at end of step, h1 (m)	Duration of step, t (s)	Release rate (L/s)
0.270	0.22	2,004	1.0
0.22	0.17	2,248	0.9
0.17	0.12	2,611	0.8
0.12	0.07	3,242	0.6
0.07	0.02	4,879	0.4
0.02	0.00	5,603	0.1

Total draindown duration 20,586 seconds
6 hours

Average release rate (by water depth) 0.7 L/s

5. Vortex ICD Sizing

Proposed Development - 1050-1060 Bank Str.

Project No.	190500700
Date	Nov 25, 2019
Prepared By:	D Glauser
Checked By	J Fookes

ICD sizing

100-yr elevation	71.40 m
Cover elevation	72.00 m
Invert elevation	70.20 m
Outlet pipe dia	250 mm

Orifice Sizing:

100-yr depth	1.33 m (depth above centreline of orifice)
Design flow	2.4 l/s
Orifice area	781 mm ² (calculated by Orifice Equation: $Q=CA(2gh)^{0.5}$ where $C=0.61$)
Orifice diameter	32 mm (if less than 75mm then vortex ICD required)

CBMH1 - Western Setback				
DESIGN EVENT	DIAMETER OF OUTLET PIPE	ICD	DESIGN FLOW (l/s)	UPSTREAM HEAD (m)
1:100 YR	250mm	IPEX Tempest LMF ICD	2.4	1.20

Chart 1: LMF 14 Preset Flow Curves

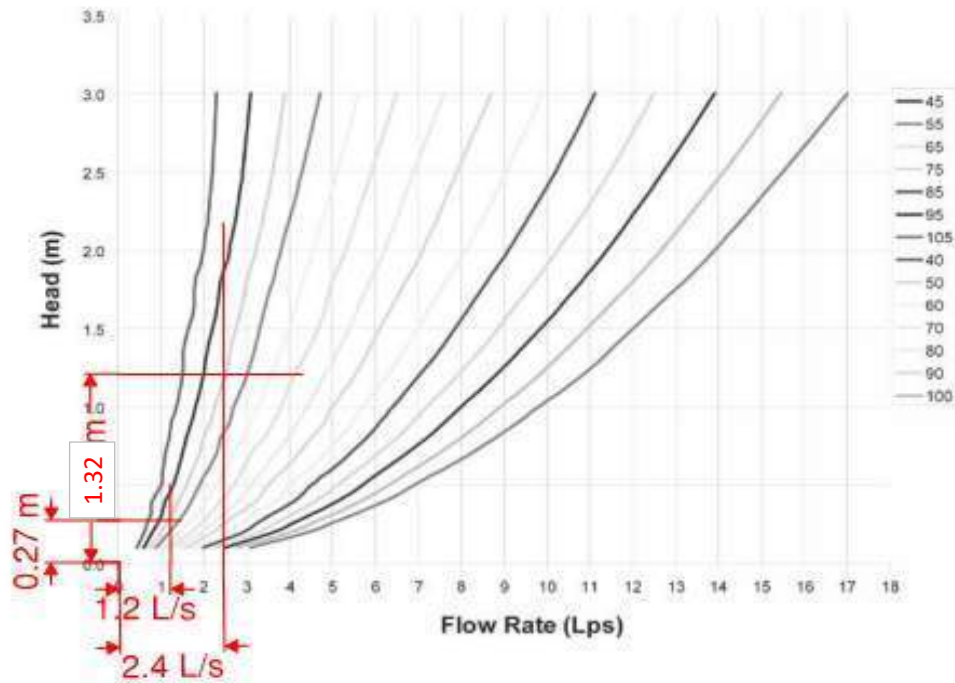

StormBrixx® HD

StormBrixx® HD is ACO's heavy duty plastic geocellular surface water management system. It consists of a single, recyclable, polypropylene body that can be assembled in a variety of ways to form an open bonded structure.

50
YEARS
DESIGN LIFE

SD
14.75' Max
depth to
invert
4.5m

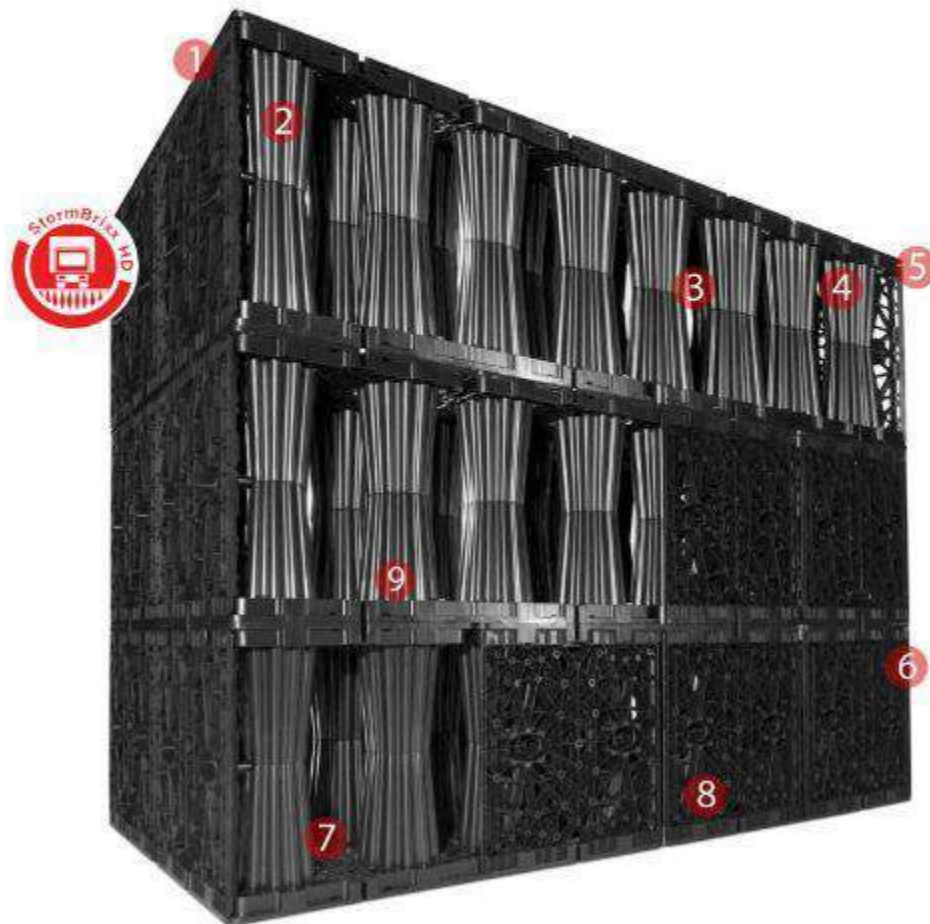

- 1 4.5 Half bodies per cubic metre
- 2 Functional design combined with an intelligent snap-lock system make for easy handling and rapid installation
- 3 High void ratio of 97% of total volume available for storage
- 4 Height of 1 layer: 24" (610mm)
- 5 Min. cover depth (see image above): 19.7" (0.5m)
- 6 StormBrixx® units can be cut in half to allow integration into the overall system
- 7 The open structure of StormBrixx® allows inspection cameras and cleaning devices to have free passage through the system

4. MAINTENANCE

Operation

ACO StormBrixx has been designed to function in conjunction with the engineered drainage system on site. Operations will be driven by naturally occurring systems and will function autonomously. However, upholding a proper schedule of inspection and maintenance is critical to ensure continued functionality and optimum performance of the system.

Inspection

Both ACO StormBrixx and any other stormwater pre-treatment features incorporated must be inspected regularly. Inspection frequency must be determined based on the contributing drainage area, but should never exceed one year between inspections (six months during the first year of operation). Inspections may be required more frequently for pre-treatment systems. Refer to the manufacturer requirements for the proper inspection schedule. Inspection and measurements can be accomplished from the surface without physically entering any confined spaces. If inspection requires confined space entry, all local/regional requirements must be followed.

StormBrixx may incorporate inspection ports, access/maintenance ports, and/or adjoining manholes. Each of these features are easily accessed by removing the cover at the surface. With the cover removed, a visual inspection can be performed to identify sediment deposits within the structure. All access points should be examined to complete a thorough inspection.



ACO StormBrixx Inspection & Maintenance

Maintenance Procedures

It is important to note that failure to control and remove sediment build-up in a sustainable drainage system is the single largest cause of system failure. To ensure effective management of silt in an ACO StormBrixx infiltration system, a sediment forebay can be incorporated. Pretreatment prior to the geocellular tank is recommended.

As sediment has the potential to carry high levels of pollutants, it is important that any sediment removed from the system is disposed of by a licensed contractor in accordance with local regulations.

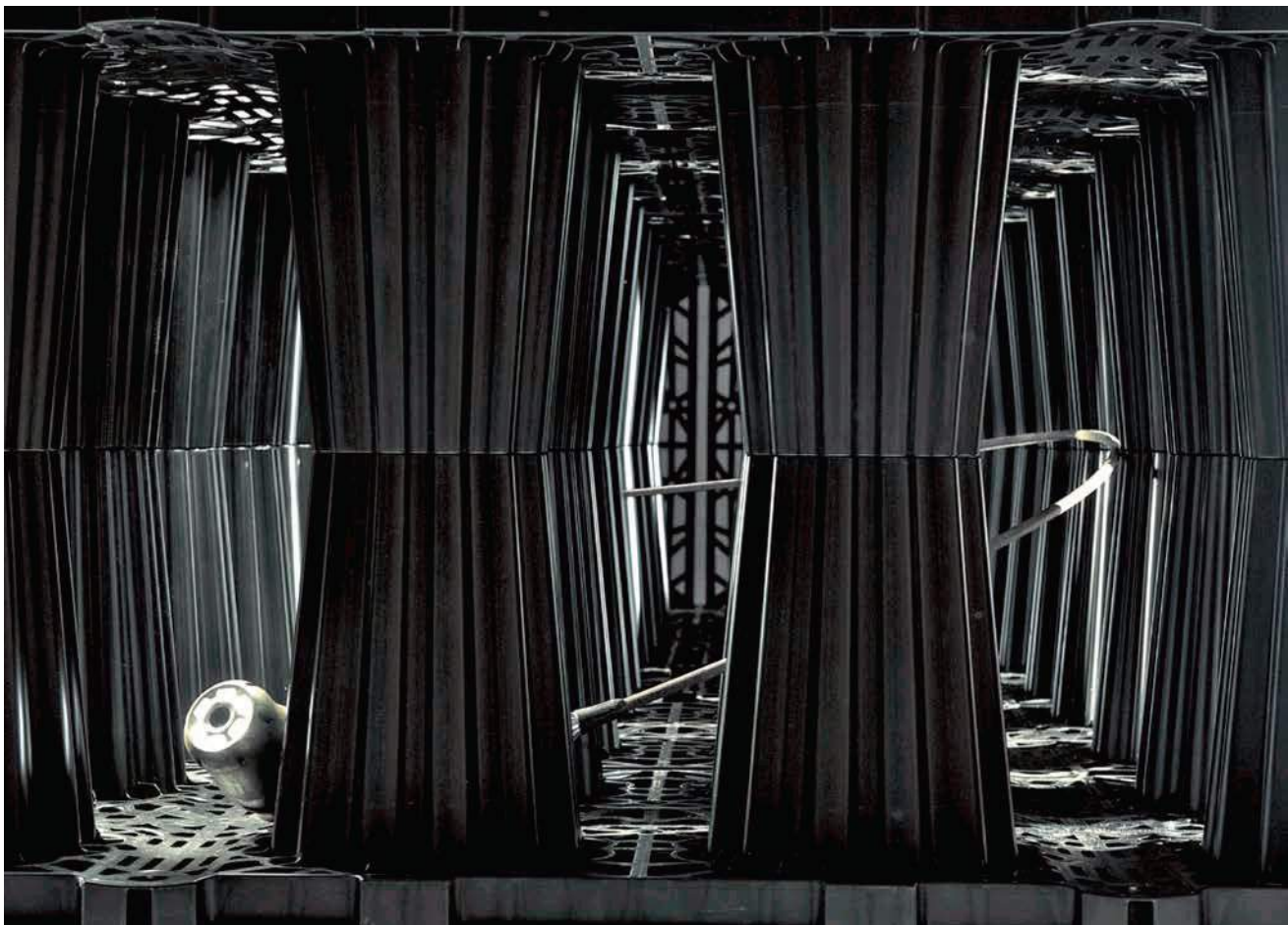



INFILTRATION SYSTEMS

In order to periodically check the effectiveness of the ACO StormBrixx infiltration system, a percolation test can be carried out on the system and compared with the original data. If there is a significant decrease in the infiltration rates, the infiltration system should be filled via the inspection chamber to the invert level of the inlet pipe. It should then be flushed through with water in order to remove sediment and unbind the geotextile.

DETENTION SYSTEMS

Block the outflow control device—but not the overflow pipe—before filling the detention system to the invert level of the vent pipe. The system should then be filled, then flushed, and the water effluent removed and disposed of by a pumped tanker.

The frequency of the maintenance procedure for ACO StormBrixx systems will be determined by the inspection team. ACO recommends inspections be carried out twice during the first year, yearly after, and after significant storm events. In order to minimize silt build-up, ACO also recommends the use of pretreatment systems upstream of the detention device.

PRODUCT INFORMATION: TEMPEST LOW, MEDIUM FLOW (LMF) ICD

Purpose

To control the amount of storm water runoff entering a sewer system by allowing a specified flow volume out of a catch basin or manhole at a specified head. This approach conserves pipe capacity so that catch basins downstream do not become uncontrollably surcharged, which can lead to basement floods, flash floods and combined sewer overflows.

Product Description

Our LMF ICD is designed to accommodate catch basins or manholes with sewer outlet pipes 6" in diameter and larger. Any storm sewer larger than 12" may require custom modification. However, IPEX can custom build a TEMPEST device to accommodate virtually any storm sewer size.

Available in 14 preset flow curves, the LMF ICD has the ability to provide flow rates: 2lps – 17lps (31gpm – 270gpm)

Product Function

The LMF ICD vortex flow action allows the LMF ICD to provide a narrower flow curve using a larger orifice than a conventional orifice plate ICD, making it less likely to clog. When comparing flows at the same head level, the LMF ICD has the ability to restrict more flow than a conventional ICD during a rain event, preserving greater sewer capacity.

Product Construction

Constructed from durable PVC, the LMF ICD is light weight 8.9 Kg (19.7 lbs).

Product Applications

Will accommodate both square and round applications:

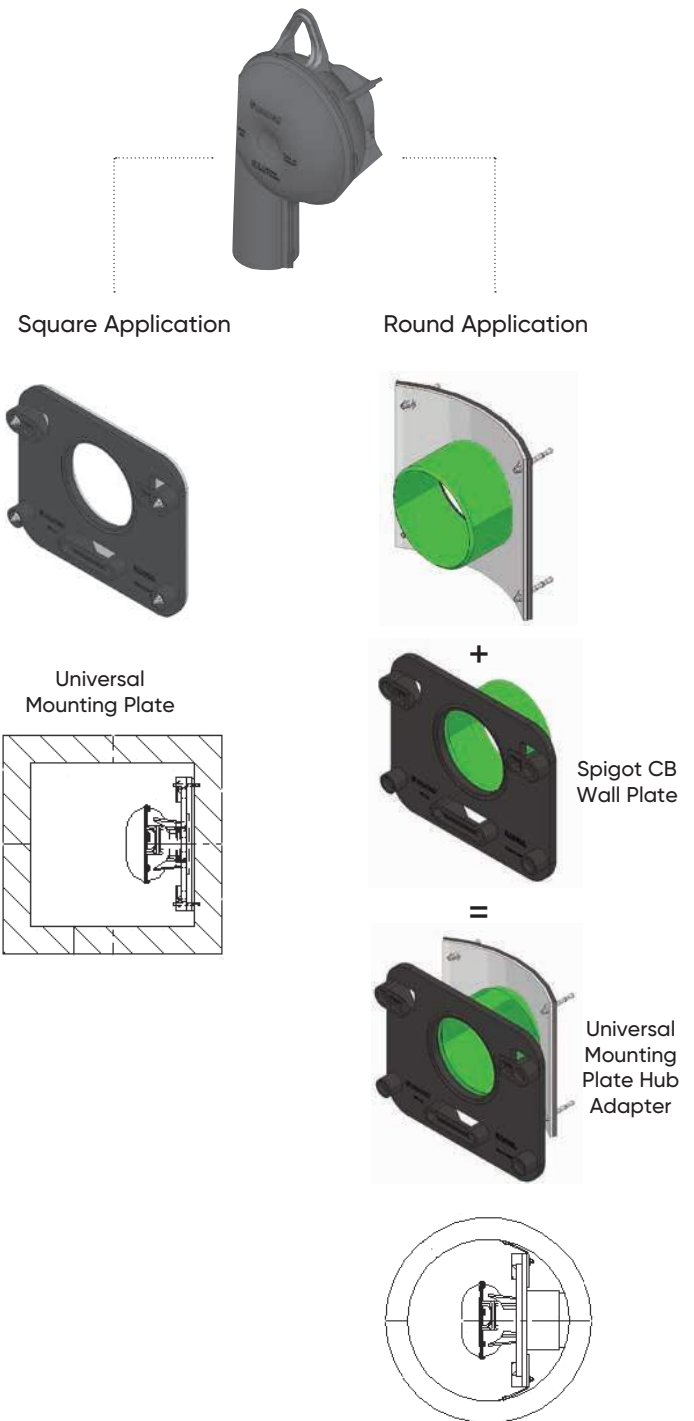

Chart 1: LMF 14 Preset Flow Curves

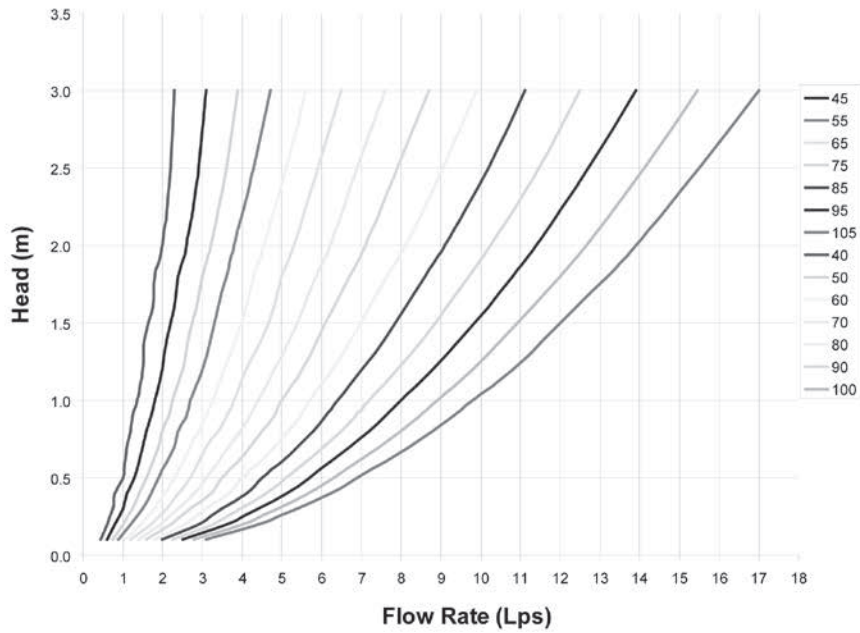
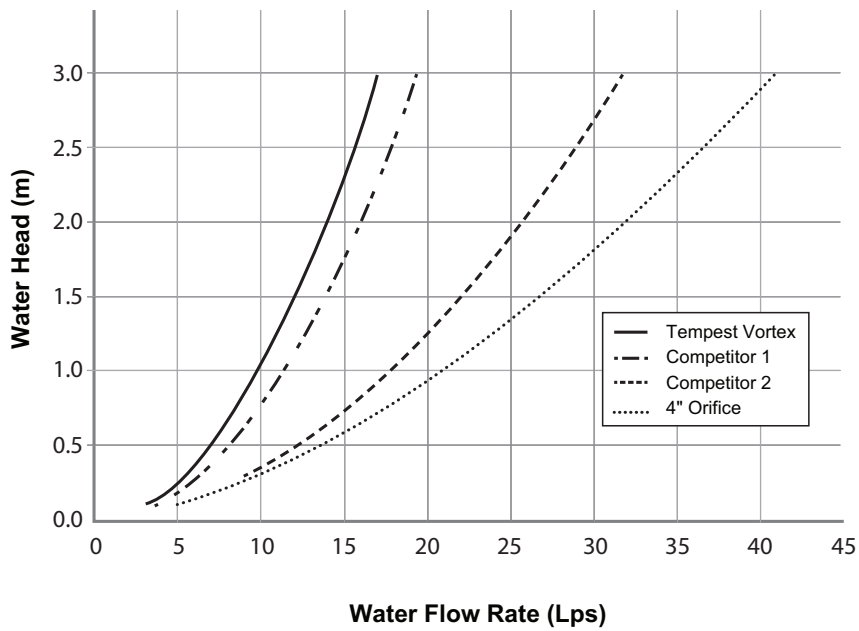

Chart 2: LMF Flow vs. ICD Alternatives



PRODUCT INSTALLATION

Instructions to assemble a TEMPEST LMF ICD into a Square Catch Basin:

STEPS:

1. Materials and tooling verification:
 - Tooling: impact drill, 3/8" concrete bit, torque wrench for 9/16" nut, hand hammer, level, and marker.
 - Material: (4) concrete anchor 3/8 x 3-1/2, (4) washers, (4) nuts, universal mounting plate, ICD device.
2. Use the mounting wall plate to locate and mark the hole (4) pattern on the catch basin wall. You should use a level to ensure that the plate is at the horizontal.
3. Use an impact drill with a 3/8" concrete bit to make the four holes at a minimum of 1-1/2" depth up to 2-1/2". Clean the concrete dust from the holes.
4. Install the anchors (4) in the holes by using a hammer. Thread the nuts on the top of the anchors to protect the threads when you hit the anchors with the hammer. Remove the nuts from the ends of the anchors.
5. Install the universal mounting plate on the anchors and screw the 4 nuts in place with a maximum torque of 40 N.m (30 lbf-ft). There should be no gap between the wall mounting plate and the catch basin wall.
6. From the ground above using a reach bar, lower the ICD device by hooking the end of the reach bar to the handle of the ICD device. Align the triangular plate portion into the mounting wall plate. Push down the device to be sure it has centered in to the universal mounting plate and has created a seal.



WARNING

- Verify that the outlet pipe doesn't protrude into the catch basin. If it does, cut down the pipe flush to the catch basin wall.
- Call your IPEX representative for more information or if you have any questions about our products.

Instructions to assemble a TEMPEST LMF ICD into a Round Catch Basin:

STEPS:

1. Materials and tooling verification.
 - Tooling: impact drill, 3/8" concrete bit, torque wrench for 9/16" nut, hand hammer, level and marker.
 - Material: (4) concrete anchor 3/8 x 3-1/2, (4) washers and (4) nuts, spigot CB wall plate, universal mounting plate hub adapter, ICD device.
2. Use the spigot catch basin wall plate to locate and mark the hole (4) pattern on the catch basin wall. You should use a level to ensure that the plate is at the horizontal.
3. Use an impact drill with a 3/8" concrete bit to make the four holes at a depth between 1-1/2" to 2-1/2". Clean the concrete dust from the holes.
4. Install the anchors (4) in the holes by using a hammer. Thread the nuts on the top of the anchors to protect the threads when you hit the anchors with the hammer. Remove the nuts from the ends of the anchors.
5. Install the CB spigot wall plate on the anchors and screw the 4 nuts in place with a maximum torque of 40 N.m (30 lbf-ft). There should be no gap between the spigot wall plate and the catch basin wall.
6. Apply solvent cement on the hub of the universal mounting plate, hub adapter and the spigot of the CB wall plate, then slide the hub over the spigot. Make sure the universal mounting plate is at the horizontal and its hub is completely inserted onto the spigot. Normally, the corners of the universal mounting plate hub adapter should touch the catch basin wall.
7. From ground above using a reach bar, lower the ICD device by hooking the end of the reach bar to the handle of the ICD device. Align the triangular plate portion into the mounting wall plate. Push down the device to be sure it has centered in to the mounting plate and has created a seal.



WARNING

- Verify that the outlet pipe doesn't protrude into the catch basin. If it does, cut back the pipe flush to the catch basin wall.
- The solvent cement which is used in this installation is to be approved for PVC.
- The solvent cement should not be used below 0°C (32°F) or in a high humidity environment. Refer to the IPEX solvent cement guide to confirm the required curing time or visit the IPEX Online Solvent Cement Training Course available at ipexna.com.
- Call your IPEX representative for more information or if you have any questions about our products.

PRODUCT TECHNICAL SPECIFICATION

General

Inlet control devices (ICD's) are designed to provide flow control at a specified rate for a given water head level and also provide odour and floatable control. All ICD's will be IPEX Tempest or approved equal.

All devices shall be removable from a universal mounting plate. An operator from street level using only a T-bar with a hook will be able to retrieve the device while leaving the universal mounting plate secured to the catch basin wall face. The removal of the TEMPEST devices listed above must not require any unbolting or special manipulation or any special tools.

High Flow (HF) Sump devices will consist of a removable threaded cap which can be accessible from street level with out entry into the catchbasin (CB). The removal of the threaded cap shall not require any special tools other than the operator's hand.

ICD's shall have no moving parts.

Materials

ICD's are to be manufactured from Polyvinyl Chloride (PVC) or Polyurethane material, designed to be durable enough to withstand multiple freeze-thaw cycles and exposure to harsh elements.

The inner ring seal will be manufactured using a Buna or Nitrile material with hardness between Duro 50 and Duro 70.

The wall seal is to be comprised of a 3/8" thick Neoprene Closed Cell Sponge gasket which is attached to the back of the wall plate.

All hardware will be made from 304 stainless steel.

Dimensioning

The Low Medium Flow (LMF), High Flow (HF) and the High Flow (HF) Sump shall allow for a minimum outlet pipe diameter of 200mm with a 600mm deep Catch Basin sump.

Installation

Contractor shall be responsible for securing, supporting and connecting the ICD's to the existing influent pipe and catchbasin/manhole structure as specified and designed by the Engineer.

Appendix F

Site Servicing Checklist

4. Development Servicing Study Checklist

The following section describes the checklist of the required content of servicing studies. It is expected that the proponent will address each one of the following items for the study to be deemed complete and ready for review by City of Ottawa Infrastructure Approvals staff.

The level of required detail in the Servicing Study will increase depending on the type of application. For example, for Official Plan amendments and re-zoning applications, the main issues will be to determine the capacity requirements for the proposed change in land use and confirm this against the existing capacity constraint, and to define the solutions, phasing of works and the financing of works to address the capacity constraint. For subdivisions and site plans, the above will be required with additional detailed information supporting the servicing within the development boundary.

4.1 General Content

- | | | |
|-----|-------------------------------------|--|
| N/A | <input type="checkbox"/> | Executive Summary (for larger reports only). |
| | <input checked="" type="checkbox"/> | Date and revision number of the report. |
| | <input checked="" type="checkbox"/> | Location map and plan showing municipal address, boundary, and layout of proposed development. |
| | <input checked="" type="checkbox"/> | Plan showing the site and location of all existing services. |
| | <input checked="" type="checkbox"/> | Development statistics, land use, density, adherence to zoning and official plan, and reference to applicable subwatershed and watershed plans that provide context to which individual developments must adhere. |
| | <input checked="" type="checkbox"/> | Summary of Pre-consultation Meetings with City and other approval agencies. |
| N/A | <input type="checkbox"/> | Reference and confirm conformance to higher level studies and reports (Master Servicing Studies, Environmental Assessments, Community Design Plans), or in the case where it is not in conformance, the proponent must provide justification and develop a defensible design criteria. |
| | <input checked="" type="checkbox"/> | Statement of objectives and servicing criteria. |
| | <input checked="" type="checkbox"/> | Identification of existing and proposed infrastructure available in the immediate area. |
| N/A | <input type="checkbox"/> | Identification of Environmentally Significant Areas, watercourses and Municipal Drains potentially impacted by the proposed development (Reference can be made to the Natural Heritage Studies, if available). |

- Concept level master grading plan to confirm existing and proposed grades in the development. This is required to confirm the feasibility of proposed stormwater management and drainage, soil removal and fill constraints, and potential impacts to neighbouring properties. This is also required to confirm that the proposed grading will not impede existing major system flow paths.
- N/A Identification of potential impacts of proposed piped services on private services (such as wells and septic fields on adjacent lands) and mitigation required to address potential impacts.
- Proposed phasing of the development, if applicable.
- Reference to geotechnical studies and recommendations concerning servicing.
- All preliminary and formal site plan submissions should have the following information:
- Metric scale
 - North arrow (including construction North)
 - Key plan
 - Name and contact information of applicant and property owner
 - Property limits including bearings and dimensions
 - Existing and proposed structures and parking areas
 - Easements, road widening and rights-of-way
 - Adjacent street names

4.2 Development Servicing Report: Water

- N/A Confirm consistency with Master Servicing Study, if available
- Availability of public infrastructure to service proposed development
- Identification of system constraints
- Identify boundary conditions
- Confirmation of adequate domestic supply and pressure
- Confirmation of adequate fire flow protection and confirmation that fire flow is calculated as per the Fire Underwriter's Survey. Output should show available fire flow at locations throughout the development.
- Provide a check of high pressures. If pressure is found to be high, an assessment is required to confirm the application of pressure reducing valves.
- N/A Definition of phasing constraints. Hydraulic modeling is required to confirm servicing for all defined phases of the project including the ultimate design
- Address reliability requirements such as appropriate location of shut-off valves
- N/A Check on the necessity of a pressure zone boundary modification.

- Reference to water supply analysis to show that major infrastructure is capable of delivering sufficient water for the proposed land use. This includes data that shows that the expected demands under average day, peak hour and fire flow conditions provide water within the required pressure range
- Description of the proposed water distribution network, including locations of proposed connections to the existing system, provisions for necessary looping, and appurtenances (valves, pressure reducing valves, valve chambers, and fire hydrants) including special metering provisions.
- N/A Description of off-site required feeder mains, booster pumping stations, and other water infrastructure that will be ultimately required to service proposed development, including financing, interim facilities, and timing of implementation.
- Confirmation that water demands are calculated based on the City of Ottawa Design Guidelines.
- Provision of a model schematic showing the boundary conditions locations, streets, parcels, and building locations for reference.

4.3 Development Servicing Report: Wastewater

- Summary of proposed design criteria (Note: Wet-weather flow criteria should not deviate from the City of Ottawa Sewer Design Guidelines. Monitored flow data from relatively new infrastructure cannot be used to justify capacity requirements for proposed infrastructure).
- N/A Confirm consistency with Master Servicing Study and/or justifications for deviations.
- Consideration of local conditions that may contribute to extraneous flows that are higher than the recommended flows in the guidelines. This includes groundwater and soil conditions, and age and condition of sewers.
- Description of existing sanitary sewer available for discharge of wastewater from proposed development.
- Verify available capacity in downstream sanitary sewer and/or identification of upgrades necessary to service the proposed development. (Reference can be made to previously completed Master Servicing Study if applicable)
- N/A Calculations related to dry-weather and wet-weather flow rates from the development in standard MOE sanitary sewer design table (Appendix 'C') format.
- N/A Description of proposed sewer network including sewers, pumping stations, and forcemains.

- Discussion of previously identified environmental constraints and impact on servicing (environmental constraints are related to limitations imposed on the development in order to preserve the physical condition of watercourses, vegetation, soil cover, as well as protecting against water quantity and quality).
- N/A Pumping stations: impacts of proposed development on existing pumping stations or requirements for new pumping station to service development.
- N/A Forcemain capacity in terms of operational redundancy, surge pressure and maximum flow velocity.
- N/A Identification and implementation of the emergency overflow from sanitary pumping stations in relation to the hydraulic grade line to protect against basement flooding.
- Special considerations such as contamination, corrosive environment etc.

4.4 Development Servicing Report: Stormwater Checklist

- Description of drainage outlets and downstream constraints including legality of outlets (i.e. municipal drain, right-of-way, watercourse, or private property)
- Analysis of available capacity in existing public infrastructure.
- A drawing showing the subject lands, its surroundings, the receiving watercourse, existing drainage patterns, and proposed drainage pattern.
- Water quantity control objective (e.g. controlling post-development peak flows to pre-development level for storm events ranging from the 2 or 5 year event (dependent on the receiving sewer design) to 100 year return period); if other objectives are being applied, a rationale must be included with reference to hydrologic analyses of the potentially affected subwatersheds, taking into account long-term cumulative effects.
- Water Quality control objective (basic, normal or enhanced level of protection based on the sensitivities of the receiving watercourse) and storage requirements.
- Description of the stormwater management concept with facility locations and descriptions with references and supporting information.
- N/A Set-back from private sewage disposal systems.
- N/A Watercourse and hazard lands setbacks.
- Record of pre-consultation with the Ontario Ministry of Environment and the Conservation Authority that has jurisdiction on the affected watershed.
- N/A Confirm consistency with sub-watershed and Master Servicing Study, if applicable study exists.

- Storage requirements (complete with calculations) and conveyance capacity for minor events (1:5 year return period) and major events (1:100 year return period).
- N/A Identification of watercourses within the proposed development and how watercourses will be protected, or, if necessary, altered by the proposed development with applicable approvals.
- Calculate pre and post development peak flow rates including a description of existing site conditions and proposed impervious areas and drainage catchments in comparison to existing conditions.
- N/A Any proposed diversion of drainage catchment areas from one outlet to another.
- Proposed minor and major systems including locations and sizes of stormwater trunk sewers, and stormwater management facilities.
- N/A If quantity control is not proposed, demonstration that downstream system has adequate capacity for the post-development flows up to and including the 100-year return period storm event.
- N/A Identification of potential impacts to receiving watercourses
- N/A Identification of municipal drains and related approval requirements.
- Descriptions of how the conveyance and storage capacity will be achieved for the development.
- 100 year flood levels and major flow routing to protect proposed development from flooding for establishing minimum building elevations (MBE) and overall grading.
- N/A Inclusion of hydraulic analysis including hydraulic grade line elevations.
- Description of approach to erosion and sediment control during construction for the protection of receiving watercourse or drainage corridors.
- N/A Identification of floodplains – proponent to obtain relevant floodplain information from the appropriate Conservation Authority. The proponent may be required to delineate floodplain elevations to the satisfaction of the Conservation Authority if such information is not available or if information does not match current conditions.
- N/A Identification of fill constraints related to floodplain and geotechnical investigation.

4.5 Approval and Permit Requirements: Checklist

The Servicing Study shall provide a list of applicable permits and regulatory approvals necessary for the proposed development as well as the relevant issues affecting each approval. The approval and permitting shall include but not be limited to the following:

- N/A Conservation Authority as the designated approval agency for modification of floodplain, potential impact on fish habitat, proposed works in or adjacent to a watercourse, cut/fill permits and Approval under Lakes and Rivers Improvement Act. The Conservation Authority is not the approval authority for the Lakes and Rivers Improvement Act. Where there are Conservation Authority regulations in place, approval under the Lakes and Rivers Improvement Act is not required, except in cases of dams as defined in the Act.
- N/A Application for Certificate of Approval (CofA) under the Ontario Water Resources Act.
- N/A Changes to Municipal Drains.
- N/A Other permits (National Capital Commission, Parks Canada, Public Works and Government Services Canada, Ministry of Transportation etc.)

4.6 Conclusion Checklist

- Clearly stated conclusions and recommendations
- Comments received from review agencies including the City of Ottawa and information on how the comments were addressed. Final sign-off from the responsible reviewing agency.
- All draft and final reports shall be signed and stamped by a professional Engineer registered in Ontario

Appendix G

Topographic and Legal Survey

TOPOGRAPHIC PLAN OF SURVEY OF

PART OF LOTS 2, 3, 4, 5, 6 AND 7 REGISTERED PLAN 101126 AND PART OF LOT A REGISTERED PLAN 116274 CITY OF OTTAWA

Scale 1:150
0 1.5 3 6 9 12 15 metres

FARLEY, SMITH & DENIS SURVEYING LTD. 2018

Metric Note
Distances and coordinates on this plan are in metres and can be converted to feet by dividing by 0.3048.

Distance Note
Distances shown on this plan are ground distances and can be converted to grid distances by multiplying by the combined scale factor of 0.99945.

Bearing Note
Bearings are given and are derived from the northerly limit of Euclid Avenue having a magnetic declination of 10.15 minutes East (MAG) as shown on the City of Ottawa utility sheets.

Elevation Notes
1. Elevations shown are geodetic and are referred to Geodetic Datum CGVD-1978-1978.
2. Elevations are derived from a site benchmark shown on a plan of survey by (1992) dated May 20th, 2016 having a published elevation of 76.87 metres (FSD No. 116-16).
3. It is the responsibility of the user of this information to verify that its relative elevation and description has not been altered or disturbed and that its relative elevation and description agrees with the information shown on this drawing.

Utility Notes
1. This drawing cannot be accepted as acknowledging all of the utilities and it will be the responsibility of the user to contact the respective utility authorities for confirmation.
2. Only visible surface utilities were located.
3. Underground utility data derived from City of Ottawa utility sheet reference H-12-11, plan no. 2538 sheet 7 of 7, drawing 11617p&10 and drawing 11617p&16.
4. Sanitary and storm sewer grades and inverts were compiled from field measurement and City of Ottawa utility sheets.
5. A field location of underground plan by the pertinent utility authority is mandatory before any work involving breaking ground, probing, excavating etc.

Notes & Legend
Denotes
SSIB Survey Monument Planted
SSIB Survey Monument Found
CB Short Standard Iron Bar
IP Iron Bar
C/Cut Cross
CP Concrete Pin
W/Witness
M/Meas
(P1) Registered Plan 158
(P2) Registered Plan 116274
(P3) Registered Plan 101126
(P4) Plan 4R-19507
(P5) Plan 4R-19507
(P6) Plan 4R-9199
(P7) Plan By (1319) Dated November 21, 1989 (Ref. 1-101126 & 2-116274)
(P8) Plan By (1319) Dated October 19, 1992 (Ref. 1-158)
(P9) Plan By (AOC) Dated March 25, 2003 (Job No. 4251-03)
(P10) Plan By (AOC) Dated August 19, 1987 (Job No. 463-87)
(P11) Plan By (857) Dated April 10, 1974 (Ref. 2-101126)
(D1) Inst. N51920
(D2) Inst. N619297
MH-ST Maintenance Hole (Storm)
MH-S Maintenance Hole (Sanitary)
MH-T Maintenance Hole (Traffic)
MH-H Maintenance Hole (Hydro)
ST Undergroud Storm Sewer
S Undergroud Sanitary Sewer
U Undergroud Water
OW Undergroud Power
B Undergroud Bell
T Undergroud Traffic Signal Cable
G Undergroud Gas
UP Utility Pole
AN Anchor
LS Light Standard
CB Catch Basin
BR Catch Basin Inlet
FH Fire Hydrant
WV Water Valve
SP Water Stand Post
In Invert
T/G Top of Grate
M Gas Meter
TB-T Traffic Terminal Box
B Billboard
S Sign
M-W Monitoring Well
D Diameter
CLF Chain Link Fence
BF Board Fence
CRW Concrete Retaining Wall
SRW Stone Retaining Wall
TW Timber Retaining Wall
WF West Face
low Top of Wall
C/L Centreline
T/Fdn Top of Foundation
U/Eave Underside of Eave
TOS Top of Slope
Eos Bottom of Slope
+65.00 Location of Elevations
+65.00 Top of Concrete Curb Elevation
Property Line
Deciduous Tree

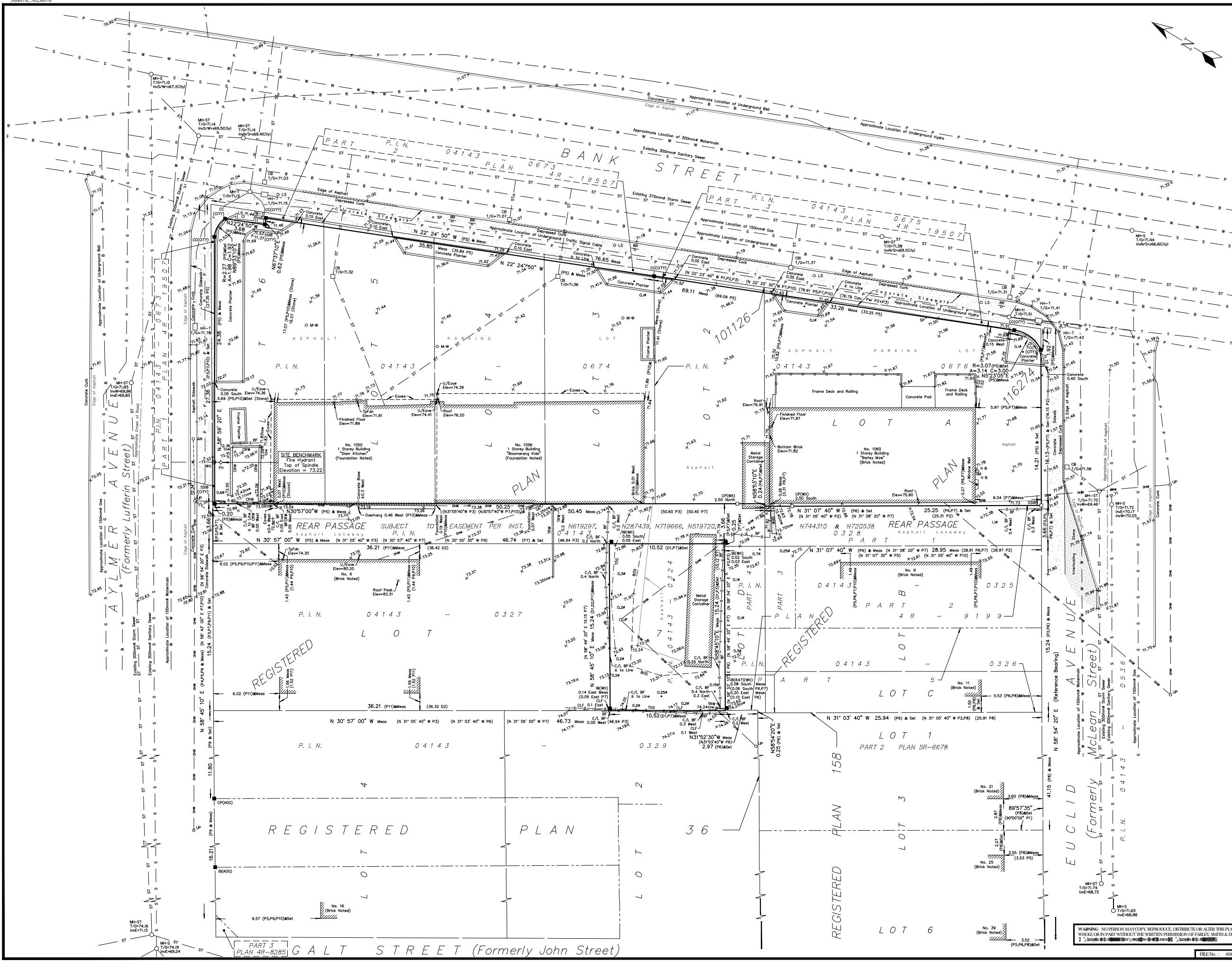

Surveyor's Certificate
I certify that:
1. This survey and plan are correct and in accordance with the Surveys Act, the Surveyors Act and the Regulations made under them.
2. The survey was completed on the 11th day of September, 2018.

Date: _____ Daniel Robinson
Ontario Land Surveyor

FARLEY, SMITH & DENIS SURVEYING LTD.
ONTARIO LAND SURVEYORS
CANADIAN SURVEYORS

190 COLONNADE ROAD, OTTAWA, ONTARIO K2E7J5
TEL: (613) 727-8226 FAX: (613) 727-1826

WARNING: NO PERSON MAY COPY, REPRODUCE, DISTRIBUTE OR ALTER THIS PLAN IN WHOLE OR IN PART WITHOUT THE WRITTEN PERMISSION OF FARLEY, SMITH & DENIS SURVEYING LTD.