



Site Servicing and Stormwater
Management Report
365 Forest Street, Ottawa, ON

Client:

11061917 Canada Inc.
200-768 St. Joseph Boulevard
Gatineau, QC J8Y 4B8

Submitted for:

Site Plan Control, Zoning By-law Amendment & Official Plan Amendment

Project Name:

365 Forest Street

Project Number:

OTT-00252570-A0

Prepared By:

EXP
2650 Queensview Drive
Ottawa, ON K2B 8H8
t: +1.613.688.1899
f: +1.613.225.7337

Date Submitted:

2021-12-10

Site Servicing and Stormwater Management Report 365 Forest Street, Ottawa, ON

Client:

11061917 Canada Inc.
200-768 St. Joseph Boulevard
Gatineau, QC J8Y 4B8

Submitted for:

Site Plan Control, Zoning By-law Amendment & Official Plan Amendment

Project Name:

365 Forest Street

Project Number:

OTT-00252570-A0

Prepared By:

EXP
2650 Queensview Drive
Ottawa, ON K2B 8H8
t: +1.613.688.1899
f: +1.613.225.7337



Prepared by:

A handwritten signature in black ink that reads "Jennifer Diaz".

Jennifer Diaz, P.Eng.
Project Engineer

Approved by:

A handwritten signature in blue ink that reads "Bruce Thomas".

Bruce Thomas, P.Eng.
Senior Project Manager

Date Submitted:

2021-12-10

Table of Contents

1	Introduction	1
1.1	Overview	1
2	Existing Conditions.....	2
3	Existing Infrastructure.....	2
4	Water Servicing.....	4
4.1	Existing Water Servicing.....	4
4.2	Water Servicing Proposal	4
4.3	Water Servicing Design	4
4.4	Water Servicing Design Criteria	5
4.5	Estimated Water Demands	6
4.6	Boundary Conditions.....	6
4.7	Fire Flow Requirements	6
4.8	Review of Hydrant Spacing	7
5	Sewage Servicing	8
5.1	Existing Sewage Conditions.....	8
5.2	Proposed Sewage Conditions.....	8
6	Storm Servicing & Stormwater Management.....	10
6.1	Design Criteria.....	10
6.2	Minor System Design Criteria	10
6.3	Major System Design Criteria.....	11
6.4	Runoff Coefficients.....	11
6.5	Time of Concentration	12
6.6	Pre-Development Conditions.....	12
6.7	Allowable Release Rate	12
6.8	Proposed Stormwater System	13
6.9	Flow Attenuation	14
7	Erosion & Sediment Control	16
8	Conclusions and Recommendations.....	17
9	Legal Notification.....	18

List of Figures

Figure 1-1 - Site Location.....	1
Figure A-1 - Pre-Development Drainage Areas	A
Figure A-2 - Post-Development Drainage Areas.....	A
Figure A-3 – Hydrant Location Plan.....	A
Figure A-4 – Roof Catchments.....	A
Figure A-5 – Fire Flow Distance Plan	A

List of Tables

Table 4-1 - Summary of Water Supply Design Criteria.....	5
Table 4-2 : Water Demand Summary	6
Table 4-3 - Summary of Design Parameters Used in Calculating Required Fire Flows (RFF) Using FUS.....	7
Table 4-4 – Required Fire Flows	7
Table 5-1 – Summary of Existing Sewage Flows.....	8
Table 5-2 – Summary of Wastewater Design Criteria / Parameters	8
Table 5-3 – Summary of Anticipated Sewage Rates.....	9
Table 6-1 – Spillway Elevations	11
Table 6-2 – Summary of Runoff Coefficients.....	12
Table 6-3 – Summary of Pre-Development Flows.....	12
Table 6-4 – Summary of Allowable Release Rates	12
Table 6-5 – Summary of Proposed Storm System.....	13
Table 6-6 – Summary of Post-Development Flows	14
Table 6-7 – Summary of Post-Development Storage	15
Table 6-8 – Summary of Ponding Storage Depths on Roof	15
Table B-1 – Water Demand Chart	B
Table B-2 – Fire Flow Requirements Based on Fire Underwriters Survey (FUS) – Tower A	B
Table B-3 – Fire Flow Requirements Based on Fire Underwriters Survey (FUS) – Tower B	B
Table B-4 – Available Fire Flows Based on Hydrant Spacing	B
Table B-5 – Estimated Water Pressure at Proposed Building.....	B
Table C-6 – Sanitary Sewer Design Sheet	C
Table D-7 – Average Runoff Coefficients for Pre-Development.....	D
Table D-8 – Estimation of Pre-Development Peak Flows	D
Table D-9 – Estimation of Allowable Peak Flows (Based on Max C=0.50 with Tc=10mins)	D
Table D-10 – Average Runoff Coefficients for Post-Development	D
Table D-11 – Summary of Post-Development Peak Flows (Uncontrolled and Controlled).....	D
Table D-12 – Storage Volumes for 2-year, 5-year and 100-Year Storms (Area PST-1).....	D
Table D-13 – Storage Volumes for 2-year, 5-year and 100-Year Storms (Area PST-3).....	D
Table D-14 – Storage Volumes for 2-year, 5-year and 100-Year Storms (Area PST-4).....	D
Table D-15 –Roof Design Sheet - Tower A.....	D

Table D-16 – Roof Design Sheet - Tower B D

List of Appendices

Appendix A - Figures A
Appendix B – Water Servicing Tables B
Appendix C – Sanitary Servicing Tables C
Appendix D – Stormwater Servicing Tables D
Appendix E – Consultation / Correspondence E
Appendix F – Background Information F
Appendix G – Checklist G
Appendix H – Drawings H

1 Introduction

1.1 Overview

EXP Services Inc. (EXP) was retained by 11061917 Canada Inc. to prepare a Site Servicing and Stormwater Management report for the proposed redevelopment of 365 Forest Street in support of Official Plan Amendment, Zoning By-Law Amendment and Site Plan Control applications.

The 0.54 hectare site is situated at the corner of Richmond Road and Forest Street as illustrated in **Figure 1-1** below. The site is within the City of Ottawa urban boundary and situated in Bay Ward. The description of the subject property is noted below:

- Part of Lots 42, 56 and 57, Registered Plan 311, in the City of Ottawa, consisting of:
- PIN 039620357 or 1420 Richmond Road.
- PIN 039620356 or 365 Forest Street.
- PIN 039620352 or 2589 Bond Street.
- PIN 039620390 & PIN 039620391, 2583 Bond Street.

The development will consist of two high-rise buildings. Tower A is a 12-storey high-rise comprised of 168 units and Tower B is 12-storey high-rise and comprised of 223 units. Below the towers, four levels of underground parking will be provided. As part of the development, a road widening will be provided to the City along Richmond Road (18.75 m from centreline), reducing the site area to 0.51 hectares.

This report will discuss the adequacy of the adjacent municipal watermain, sanitary sewers and storm sewers to provide the required water supply, convey the sewage and stormwater flows that will result from the proposed development. This report provides a design brief for submission, along with the engineering drawings, for City approval.



Figure 1-1 - Site Location

2 Existing Conditions

Within the four subject properties, there are two (2) existing buildings. The following summarizes the current land use conditions.

- 1420 Richmond Road Vacant property, but currently used as gravel parking lot.
- 365 Forest Street Automobile garage and repair shop including asphalt parking lot.
- 2589 Bond Street Automobile repair shop and asphalt parking lot.
- 2583 Bond Street Vacant property.

All four properties are zoned Arterial Mainstreet Zone (AM10).

The topography of the subject site falls in a southerly and easterly direction along Forest Street and Bond Street, with a localized roadway sag condition on Forest Street approximately $\pm 50\text{m}$ south of Richmond Road.

3 Existing Infrastructure

The site includes two commercial buildings that will be removed during the redevelopment of the site.

From review of the sewer and watermain mapping, as-built drawings and Utility Central Registry (UCC) plans, the following summarizes the onsite and adjacent offsite infrastructure:

Within property

- Storm, sanitary and watermain laterals to the two buildings that will be abandoned.

On Bond Street

- 150mm watermain
- 225mm sanitary sewer
- 300mm storm sewer
- 35mm Gas / Bell / Streetlighting/ Hydro

On Forest Street

- 300mm watermain
- 250mm sanitary sewer
- 300mm storm sewer
- Hydro /Bell / Streetlighting / Hydro

On Richmond Road

- 300mm watermain
- 225 mm sanitary sewer
- 525mm storm sewer
- 200mm Gas / Hydro / Bell / Streetlighting

As-built drawings for Bond Street, Forest Street, and Richmond Road were obtained from the City's vault and are included in **Appendix F**.

1.3 Pre-Consultation / Permits / Approvals

A pre-consultation meeting was held with the City prior to design commencement. This meeting outlined the submission requirements and provided information to assist with the development proposal. A copy of pre-consultation correspondence is included in **Appendix E**.

The proposed site is located within the Rideau Valley Conservation Authority (RVCA) jurisdiction, therefore signoff from the RVCA will be required prior to Site Plan approval. The RVCA has been contacted to confirm the stormwater management quality control requirements. A copy of the correspondence with the RCVA is attached in **Appendix E**.

Generally, an Environmental Compliance Approval (ECA) would be obtained from the Ministry of Environment, Conservation and Parks (MECP), formerly the Ministry of the Environment and Climate Change (MOECC), for any onsite private Sewage Works.

The onsite Sewage Works would generally include the onsite stormwater works such as flow controls, associated stormwater detention, and treatment works. However, an Approval Exemption under Ontario Regulation 525/98 can be applied. Under Section 3 of O. Reg 525/98, Section 53 (1) and (3) do not apply to the alteration, extension, replacement or a change to a stormwater management facility that 1) is designed to service one lot or parcel of land, b) discharges into a storm sewer that is not a combined sewer, c) does not service industrial land or a structure located on industrial land, and finally d) is not located on industrial land.

Based on this exemption, if the parcels noted above are merged into one property parcel, then by completing this the Approval Exemptions under O. Reg 525/98, would be satisfied and not require an ECA. Prior to City signoff on the infrastructure design a pre-consultation meeting will be held with the local MECP, to confirm that the site will not require an ECA.

In addition, various design guidelines were referred to in preparing the current report including:

- Bulletin ISDTB-2012-4 (20 June 2012)
 - Technical Bulletin ISDTB-2014-01 (05 February 2014)
 - Technical Bulletin PIEDTB-2016-01 (September 6, 2016)
 - Technical Bulletin ISDTB-2018-01 (21 March 2018)
 - Technical Bulletin ISDTB-2018-04 (27 June 2018)
- Ottawa Design Guidelines – Water Distribution, July 2010 (WDG001), including:
 - Technical Bulletin ISDTB-2014-02 (May 27, 2014)
 - Technical Bulletin ISTB-2018-02 (21 March 2018)
- Stormwater Management Planning and Design Manual, Ontario Ministry of the Environment and Climate Change, March 2003 (SMPDM).
- Design Guidelines for Drinking-Water Systems, Ontario Ministry of the Environment and Climate Change, 2008 (GDWS).
- Fire Underwriters Survey, Water Supply for Public Fire Protection (FUS), 1999.
- Ontario Building Code 2012, Ministry of Municipal Affairs and Housing.
- Stormwater Management Guidelines for the Pinecrest Creek/Westboro Area Final Report by JFSA
- Stormwater Management Design Criteria for Pinecrest Creek/Westboro Area, City of Ottawa Final – May 2020

4 Water Servicing

4.1 Existing Water Servicing

The subject site is within the City of Ottawa 1W pressure zone. The site is currently serviced by the existing 300mm watermain on Forest Street and the 150mm watermain on Bond Street. The two existing buildings are serviced by laterals that will be blanked at the main to satisfaction of the City's Sewer Operations prior to shoring and excavating of the building.

4.2 Water Servicing Proposal

The proposed development will consist of two high-rise buildings. Tower A is a 12-storey high-rise comprised of 168 units and Tower B is 12 storeys and comprised of 223 units. Architectural plans and rendering of the proposed building along with building statistics are provided in **Appendix H**.

Water supply for the site will be provided by twin 200mm watermains supplied from the existing watermain on Forest Street. The need for a twin watermain is the result of the average day water demands exceeding 50 m³/day. The watermain feeds from the underground parking level and will connect directly to the existing 300mm watermain on Forest Street and will have an isolation valve between them, consistent with City of Ottawa Water Design Guidelines.

The buildings will be protected by automatic sprinkler systems. A fire department connection (or siamese) will be located within 45 metres of an adjacent municipally owned fire hydrant. In order to achieve this, a new hydrant will be installed off the existing 300mm watermain within Forest Street. Detailed layout of the proposed water services is provided in drawing C100 of **Appendix H**.

4.3 Water Servicing Design

The water servicing requirements for the proposed building is designed in accordance with the City Design Guidelines (July 2010). The following steps indicate the basic methodology that was used in our analysis:

- Estimated water demands under average day, maximum day and peak hour conditions. As the total population estimate was greater than 500, standard residential peaking factors were used, rather than based on MECP Table 3-3 which would be necessary when the design population is less than 500 persons.
- Estimated the required fire flow (RFF) based on the Fire Underwriters Survey (FUS).
- Obtained hydraulic boundary conditions (HGL) from the City, based on the above water demands and required fire flows.
- Boundary condition data and water demands were used to estimate the pressure at the proposed building, and this was compared to the City's design criteria.

Since the average day demand exceed 50 m³ per day, two watermain feeds to the building will be necessary as per Section 4.31 of the WDG001. **Table B-1** in **Appendix B** provides detailed calculations of the total water demands.

A review of the estimated watermain pressures at the building connection, based on the boundary conditions provided, was completed based on using two watermains. **Table B-5** in **Appendix B** provides a comparison of anticipated pressures at the building connection based on using a single or double watermain feed. A single watermain analysis was completed to determine if the water pressure still met the City requirement during either the maximum day plus fire flow or peak hour condition, if one of the laterals was out of service.

Based on results, the use of two 150mm watermains would result in a pressure of ±50.1 psi at the building, while the use of two 200mm watermains would improve the pressure to ±52.4 psi under maximum day plus fire flow conditions. The minimal

difference in pressure is the result of the short length of the water service lateral. In the event one of the watermains are down for service, the pressure at the building using only a single 150mm or 200mm watermain would be ± 42.1 psi or ± 50.3 psi respectively.

Under peak hour conditions, there is little difference using a 150mm or 200mm watermain, with anticipated pressure at the building of ± 52.2 psi.

Based on the results, the installation of two 200mm watermains with a shut-off valve between them is proposed. Detailed calculations of the anticipated water pressures, based on City of Ottawa boundary conditions, is provided in **Table B-5**.

No pressure reducing measures are required as operating pressures are within 50 psi and 80 psi.

4.4 Water Servicing Design Criteria

Table 4-1 below summarizes the Design Criteria that was used to establish the water demands and the required fire flows, based on the proposed building uses. The design parameters that apply to this project and used for calculations are identified below in **Table 4-1**.

Table 4-1 - Summary of Water Supply Design Criteria

Design Parameter	Value	Applies
Population Density – Single-family Home	3.4 persons/unit	
Population Density – Semi-detached Home	2.7 persons/unit	
Population Density – Townhome or Terrace Flat	1.8 persons/unit	
Population Density – Bachelor Apartment	1.4 persons/unit	✓
Population Density – Bachelor + Den Apartment	1.4 persons/unit	
Population Density – One Bedroom Apartment	1.4 persons/unit	✓
Population Density – One Bedroom plus Den Apartment	1.4 persons/unit	✓
Population Density – Two Bedroom Apartment	2.1 persons/unit	✓
Population Density – Two Bedroom plus Den Apartment	2.1 persons/unit	
Average Day Demands – Residential	350 L/person/day	✓
Average Day Demands – Commercial / Institutional	28,000 L/gross ha/day	✓
Average Day Demands – Light Industrial / Heavy Industrial	35,000 or 55,000 L/gross ha/day	
Maximum Day Demands – Residential	2.5 x Average Day Demands	✓
Maximum Day Demands – Commercial / Institutional	1.5 x Average Day Demands	✓
Peak Hour Demands – Residential	2.2 x Maximum Day Demands	✓
Peak Hour Demands – Commercial / Institutional	1.8 x Maximum Day Demands	✓
Fire Flow Requirements Calculation	FUS	✓
Depth of Cover Required	2.4m	✓
Maximum Allowable Pressure	551.6 kPa (80 psi)	✓
Minimum Allowable Pressure	275.8 kPa (40 psi)	✓
Minimum Allowable Pressure during fire flow conditions	137.9 kPa (20 psi)	✓

4.5 Estimated Water Demands

The following **Table 4-2** below summarizes the anticipated water demands for the proposed development based on following:

- Tower A having 168 units and estimated population of 264.6 persons.
- Tower B having 223 units and estimated population of 342.3 persons.

Table 4-2 : Water Demand Summary

Water Demand Conditions	Tower A - Water Demands (L/sec)	Tower B - Water Demands (L/sec)	Total Water Demands (L/sec)
Average Day	1.1	1.4	2.5
Max Day	2.7	3.5	6.2
Peak Hour	5.9	7.6	13.6

4.6 Boundary Conditions

Hydraulic Grade Line (HGL) boundary conditions were obtained from the City for design purposes. A copy of the correspondence received from the City is provided in **Appendix E**.

The following hydraulic grade line (HGL) boundary conditions were provided:

- Minimum HGL = 108.3 m
- Maximum HGL = 115.4 m
- Max Day + Fire Flow (133L/sec) = 109.8 m
- Max Day + Fire Flow (183L/sec) = 109.2 m

4.7 Fire Flow Requirements

Water for fire protection will be available utilizing the proposed fire hydrants located along the adjacent roadways: Bond Street, Forest Street, Croydon Avenue, and Richmond Road. The required fire flows for the proposed buildings were calculated based on typical values as established by the Fire Underwriters Survey 1999 (FUS).

The following equation from the Fire Underwriters document “Water Supply for Public Fire Protection”, 1991, was used for calculation of the on-site supply rates required to be supplied by the hydrants:

$$F = 200 * C * \sqrt{A}$$

where:

F	=	Required Fire flow in Litres per minute
C	=	Coefficient related to type of Construction
A	=	Total Floor Area in square metres

The proceeding **Table 4-3** summarizes the parameters used for estimating the Required Fire Flows (RFF) based on the Fire Underwriters Survey (FUS) and the latest City of Ottawa Technical Bulletins. The RFFs were estimated in accordance with ISTB-2018-02, and based on floor areas provided by the architect, which are illustrated in **Appendix H**.

The following summarizes the parameters used for both proposed buildings.

- Type of Construction Non-combustible
- Occupancy Limited combustible
- Sprinkler Protection Fully Supervised Automatic Sprinkler

Table 4-3 - Summary of Design Parameters Used in Calculating Required Fire Flows (RFF) Using FUS

Design Parameter	Value
Coefficient Related to type of Construction C	0.80 (Towers A, Tower B)
Total Floor Area (m ²)	7,175 (Tower A) 9,480 (Tower B)
Fire Flow prior to reduction (L/min)	14,908 (Tower A) 17,136 (Tower B)
Reduction Due to Occupancy Non-combustible (-25%), Limited Combustible (-15%), Combustible (0%), Free Burning (+15%), Rapid Burning (+25%)	-15% (Tower A) -15% (Tower B)
Reduction due to Sprinkler (Max 50%) Sprinkler Conforming to NFPA 13 (-30%), Standard Water Supply (-10%), Fully Supervised Sprinkler (-10%)	-50% (Tower A) -50% (Tower B)
Exposures	+25% (Tower A) +46% (Tower B)

The estimated required fire flows (RFF) based on the FUS methods is: 133 L/sec for Tower A, and 183 L/sec for Tower B.

4.8 Review of Hydrant Spacing

A review of the hydrant spacing was completed to ensure compliance with Ottawa Design Guidelines – Water Distribution, July 2010 (WDG001) and Appendix I of Technical Bulletin ISTB-2018-02. To meet the fire hydrant spacing guidelines of 90m for apartments and high-density areas, an additional fire hydrant is proposed on Bond Street, approximately 25m east of Forest Street. An additional fire hydrant is proposed on Forest Avenue to be within 45m of the fire department connection on each building.

As per Section 3 of Appendix I of Technical Bulletin ISTB-2018-02, all hydrants within 150 metres were reviewed to assess the total possible available flow from these contributing hydrants. For each hydrant the distance to the proposed building was determined to arrive at the contribution of fire flow from each. All hydrants are expected to be of Class AA as per Section 5.1 of Appendix I. For each hydrant the straight-line distance, distance measured along a fire route or roadway, whether its location is accessible, and its contribution to the required fire flow was established. **Figure A-3 in Appendix A** illustrates the hydrant locations in proximity to the site.

Table 4-4 – Required Fire Flows

Building	Required Fire Flow (L/min)	Available Fire flow Based on Hydrant Spacing as per ISTB-2018-02 (L/min)
Tower A	8,000 (or 133 L/sec)	22,800
Tower B	11,000 (or 183 L/sec)	34,200

The total available contribution of flow from hydrants was estimated at ±22,800 L/min and ±34,200 L/min for Towers A and B, whereas the required fire flows (RFF) for each building is only 8,000 L/min and 11,000 L/min. Therefore, the available flows from hydrants exceed each building’s fire flow requirements as identified in Appendix I of Technical Bulletin ISTB-2018-02. Additional information on the available flows from hydrants is provided in **Table B-4**.

5 Sewage Servicing

5.1 Existing Sewage Conditions

The subject property is located within the Pinecrest Collector Sewershed, which then discharges to the West Nepean Collector. From the property sewage is discharged:

- Southerly on Forest Street (±45m of 250mm pipe),
- Easterly on Bond Street (130m of 225mm and 250mm pipe)
- Northerly on Croydon Avenue (±180m of 225mm pipe)
- Easterly on Richmond Road (±625m of 300mm pipe) to Pinecrest Collector
- Northerly on Transitway (±460m of 900mm pipe) to West Nepean Collector

Table 5-1 below summarizes the sewage flow from the existing properties.

Table 5-1 – Summary of Existing Sewage Flows

Sewage Condition	Sanitary Sewage Flow (L/sec)
Average Day Sewage Flow	0.26
Infiltration Flow (at 0.33 L/ha/sec)	0.18
Peak Wet Weather Sewage Flow	0.44

5.2 Proposed Sewage Conditions

It is proposed to provide one single sanitary sewer connection from the subject property to the existing sanitary sewer on Forest Street. Each tower will have a separate building lateral which will discharge to an onsite sanitary manhole. This manhole will be installed near the property line and be used as a monitoring manhole. The sanitary sewer system was designed based on a population flow with an area-based infiltration allowance. A 250mm diameter sanitary sewer is proposed with a minimum 2% slope, having a capacity of 87.7 L/sec based on Manning’s Equation under full flow conditions. Based on the OBC, the maximum permitted hydraulic load for a 250mm at 2% is 4,500 fixture units. **Table 5-2** below summarizes the design parameters used.

Table 5-2 – Summary of Wastewater Design Criteria / Parameters

Design Parameter	Value	Applies
Population Density – Single-family Home	3.4 persons/unit	
Population Density – Semi-detached Home	2.7 persons/unit	
Population Density – Duplex	2.3 persons/unit	
Population Density – Townhome (row)	2.7 persons/unit	
Population Density – Bachelor Apartment	1.4 persons/unit	✓
Population Density – Bachelor + Den Apartment	1.4 persons/unit	
Population Density – One Bedroom Apartment	1.4 persons/unit	✓
Population Density – One Bedroom plus Den Apartment	1.4 persons/unit	✓
Population Density – Two Bedroom Apartment	2.1 persons/unit	✓
Population Density – Two Bedroom plus Den Apartment	2.1 persons/unit	
Average Daily Residential Sewage Flow	280 L/person/day	
Average Daily Commercial / Institutional Flow	28,000 L/gross ha/day	✓
Average Light / Heavy Industrial Daily Flow	35,000 / 55,000 L/gross ha/day	
Residential Peaking Factor – Harmon Formula (Min = 2.0, Max =4.0, with K=0.8)	$M = 1 + \frac{14}{4 + P^{0.5}} * k$	✓
Commercial Peaking Factor	1.0	✓
Institutional Peaking Factor	1.5	
Industrial Peaking Factor	As per Table 4-B (SDG002)	
Unit of Peak Extraneous Flow (Dry Weather / Wet Weather)	0.05 or 0.28 L/s/gross ha	
Unit of Peak Extraneous Flow (Total I/I)	0.33 L/s/gross ha	✓

The estimated peak sanitary flow rate from the proposed property at 365 Forest Street is **6.76 L/sec** based on City Design Guidelines. Sewage rates below include a total infiltration allowance of 0.18 L/ha/sec based on the total gross site area. Refer to **Appendix C** for detailed calculations.

Sewage Flows within the property were estimated in order to compare with developed conditions. **Table 5-3** below summarizes the approximate sewage flows generated from the existing properties, based on a commercial flow and infiltration allowance.

Table 5-3 – Summary of Anticipated Sewage Rates

Sewage Condition	Sanitary Sewage Flow (L/sec)
Peak Residential / Commercial Flow	6.58
Infiltration Flow	0.18
Peak Design Flow	6.76

A review of the downstream sanitary sewer capacity was completed. The minimum sewer capacity of the last sewer run on Croydon Street (with a slope of 0.36%) has a calculated full flow capacity of 27 L/sec. It is anticipated that the increase in peak sewage flows up to 6.76 L/sec can be accommodated in the downstream sanitary sewer system.

6 Storm Servicing & Stormwater Management

Since the subject properties are located within the Ottawa River East subwatershed, stormwater works are therefore subject to both the Rideau Valley Conservation Authority (RVCA) and City of Ottawa (COO) approval.

In November 2020, after receipt of the comments from RVCA and pre-consultation with the City of Ottawa in 2019, the City of Ottawa Council approved the “Stormwater Management Design Criteria for the Pinecrest Creek/Westboro Area” (herein referred to as the Pinecrest/Westboro Criteria). The subject site falls within the Pinecrest Study Area identified on Figure 1 of the Pinecrest/Westboro Criteria and discharges directly to the Ottawa River. After multiple calls with the City of Ottawa, it was determined that the site would be required to adhere to the quality and quantity control guidelines of the Pinecrest/Westboro Criteria’s. EXP met with the City of Ottawa to confirm runoff from the site discharges to the Ottawa River and the requirements based on the Pinecrest/Westboro Criteria as it relates to the subject development. Email correspondence is provided in **Appendix E**.

6.1 Design Criteria

The proposed stormwater system is designed in conformance with the latest version of the City of Ottawa Design Guidelines (October 2012). Section 5 “Storm and Combined Sewer Design” and Section 8 “Stormwater Management”. A summary of the design criteria that relates to this design report is in the proceeding sections below.

The requirements related to stormwater quantity control were noted in the pre-consultation meeting as follows:

- *Stormwater quantity control criteria – control the quantity to the 5-year pre-development/existing level for all storms up to and including the 100-year storm.*
- *When using the modified rational method to calculate the storage requirements for the site, the underground storage should not be included in the overall available storage. The modified rational method assumes that the restricted flow rate is constant throughout the storm which, in this case, underestimates the storage requirement prior to the 1: 100-year head elevation being reached. Alternately, if you wish to include the underground storage, you may use an assumed average release rate equal to 50% of the peak allowable rate. Otherwise, disregard the underground storage as available storage or provide modeling to support the design.*

The stormwater management criteria identified for Site Plan Approval of sites within Pinecrest Creek Study Area draining to the Ottawa River are provided on Table 1: SWM Design Criteria for the Pinecrest Creek / Westboro Study Area of the Pinecrest/Westboro Criteria as follows:

- *Runoff Volume Reduction – Minimum on-site retention of the 10 mm design storm.*
- *Water Quality – 80% TSS removal, some of which may be achieved by on-site retention of first 10 mm of rainfall.*
- *Water Quantity – As per the City of Ottawa Sewer Design Guideline.*
- *Erosion Control – Not applicable.*

6.2 Runoff Volume Reduction

The reduction of flow from the site following development is provided through retention of the 10 mm design storm as follows:

- Amended topsoil in all landscaped areas.
- Calculation of the 10 mm storm volume based on the site proposed development.

- Capture and retention of the 10 mm storm volume in a cistern in the underground parking lot to store for use on-site irrigation and maintenance. Location and details of the cistern are provided on the Mechanical Plans in **Appendix H**.

6.3 Water Quality

- An oil grit separator (OGS) structure designed to remove 80% total suspended solids will be in the underground parking lot. Refer to Mechanical Plans in **Appendix H**.
- Runoff from the at grade driveway area will be collected by area drains, conveyed to the mechanical plumbing within the underground parking garage that discharges to the OGS for treatment prior to leaving the site. Details of the Oil Grit Separator are provided in **Appendix H**.

6.4 Minor System Design Criteria

- The storm sewer was sized based on the Rational Method and Manning’s Equation under free flow conditions for the 2-year storm using a 10-minute inlet time.
- Since a detailed site plan was available for the site, including building footprints, calculations of the average runoff coefficients for each drainage area were completed.
- Minimum sewer slopes to be based on minimum velocities for storm sewers of 0.80 m/sec.

6.5 Major System Design Criteria

- The major system has been designed to accommodate on-site detention with sufficient capacity to attenuate the 100-year design storm. On-site storage is calculated based on the 100-year design storm with on-site detention storage provided on the roof and within the underground parking structure (stormwater cistern).
- On site storage is provided and calculated for up to the 100-year design storm. There is no surface ponding proposed on the ground surface.
- Overland flow routes are provided.
- The vertical distance from the spill elevation on the street and the ground elevation at the buildings is at least 15cm.
- The emergency overflow spill elevation is at least 30 cm below the lowest building opening.

Table 6-1 – Spillway Elevations

Building	Spillway Elevation	Lowest building opening Elevation	Lowest Ground Elevation at Building
Tower A (Richmond Road)	74.85	75.60	75.40
Tower B (Bond St./Croydon Ave.)	74.08	74.40	74.40

6.6 Runoff Coefficients

Runoff coefficients used for were based on actual areas taken from CAD. Runoff coefficients for impervious surfaces (roofs, asphalt, and concrete) were taken as 0.90, whereas those for pervious surfaces (grass/landscaping) were taken as 0.20. Average runoff coefficients were calculated for subcatchments (or drainage areas) using the area-weighting routine in PCSWMM. The runoff coefficients for pre-development and post-development catchments are provided in **Appendix D**, with a summary provided in **Table 6-2** below.

Table 6-2 – Summary of Runoff Coefficients

Location	Area (hectares)	Pre-Development Runoff Coefficient, C_{AVG}	Post-Development Runoff Coefficient, C_{AVG}
Entire Site	0.5126	0.75	0.81

6.7 Time of Concentration

A minimum time of concentration of 10-minutes was used for both pre-development and post-development subcatchments.

6.8 Pre-Development Conditions

Under current conditions stormwater runoff from the 0.5126 hectare site is divided into two drainage areas. Stormwater runoff discharges: 1) in a northwestern direction towards Richmond Road / Forest Street and 2) in a southern direction towards Bond Street. **Figure A-1** illustrates these pre-development drainage areas. These drainage areas (or subcatchments) are derived from PCSWMM using the Watershed Delineation Tool.

Table 6-3 – Summary of Pre-Development Flows

Return Period Storm	Peak Flows to Richmond Road / Forest Street Storm Sewers (L/sec)	Peak Flows to Bond Street Storm Sewers (L/sec)	Total Peak Flows (L/sec)
2-year	21.7	60.9	82.6
5-year	29.5	82.6	112.1
100-year	63.1	176.9	240.0

6.9 Allowable Release Rate

Rather than meeting pre-development release rates, the City of Ottawa imposes a more restrictive stormwater release rate as noted in Section 8.3.7.3 of the SDG002. The allowable discharge release rate from the site was established using the peak flows derived based on a 5-year return period storm, a maximum runoff coefficient of 0.50 and a standard time of concentration of 10 minutes.

The allowable release rate of 74.3 L/sec from the proposed site will be based on a 5-year storm event. **Table D-9** provides detailed calculations on the total allowable peak flow, and the distribution to each outfall. In summary, the allowable release rate of 74.3 L/sec is comprised of 19.9 L/sec to Forest Street and 54.4 L/sec to Bond Street.

Table 6-4 – Summary of Allowable Release Rates

Area (onsite)	Area (ha)	Storm = 2 Year Q_{2ALLOW} (L/sec)	Storm = 5 Year Q_{5ALLOW} (L/sec)
Pre-1	0.1375	14.7	19.9
Pre-2	0.3751	40.0	54.4
Totals	0.5126	54.7	74.3

6.10 Proposed Stormwater System

Stormwater runoff from the proposed site will drain from a combination of controlled and uncontrolled areas. As a result of the changes onsite the overall post-development runoff coefficient will change over pre-development conditions. This increase / decrease in runoff is the result of changes due to site development (i.e. additional hard surfaces, roof areas and hard landscaping).

A storm drainage plan is illustrated on **Figure A-2**. A total five (5) subcatchments (or drainage areas) within the development site are shown on this drawing with average runoff coefficients calculated for each drainage area. As the entire site property contains an underground parking structure, the stormwater works shall consist of the following elements:

- The proposed grading for the site will generally meet the existing drainage pattern sloping from the west at Richmond Road and Forest Street southerly/easterly to Bond Street.
- Roof drainage and landscape/hard surfaces to have separate 250mm storm lateral connections to the municipal storm sewer system with the roof drainage being conveyed to Forest Street storm sewer and the remainder of the site being conveyed to Bond Street storm sewer.
- Flow-control roof drains for Towers A & B discharging to internal storm plumbing to the stormwater cistern retaining the 10 mm storm volume prior to the excess flows discharging to the municipal sewer on Forest Street.
- Runoff from surface areas will be collected by area drains and discharge to underground storage (2.0 m x 5.0 m x 6.0 m stormwater cistern) located in the underground parking structure on P2 that will detain the runoff from the site to meet allowable rates. This in turn will be conveyed by the internal storm plumbing ultimately discharging to the storm lateral outletting from Tower B to STMMH 101 at the allowable rate.
- Remaining drainage areas along frontage of Forest Street and Bond Street to flow uncontrolled overland to the right-of-way.

A summary of the proposed storm and foundation infrastructure is provided in **Table 6-5** below.

Table 6-5 – Summary of Proposed Storm System

Storm Laterals	Manhole	Foundation Drainage	Catchbasins	Area Drains
Storm Outlet #1 250mm from Underground Parking Garage to existing 300 mm Storm Sewer on Forest Street.	STMMH 102	To STMMH 101	CBE1 CB1 CBE2	AD1 through AD12
Storm Outlet #2 250 mm from Underground Parking Garage to existing 300 mm Storm Sewer on Bond Street	STMMH 100 STMMH 101		Above CBs and ADs drain to cistern at east side in Parking Garage with controlled flow to existing STMMH 100 and then the 300mm existing storm sewer on Bond Street.	

A summary of the post-development flows is provided in **Table 6-6** below.

Table 6-6 – Summary of Post-Development Flows

Return Period Storm	Peak Flows to Richmond Road / Forest Street Storm Sewers (L/sec)	Peak Flows to Bond Street Storm Sewers (L/sec)	Total Peak Flows (L/sec)	Allowable Peak Flows (L/sec)
2-year	10.4	14.5	24.9	74.3
5-year	14.1	19.7	33.8	
100-year	28.1	41.1	69.2	
Allowable to Forest / Richmond =				19.9
Allowable to Bond =				54.4

To achieve the quantity control requirements and meet the allowable discharge rates as noted in **Section 6.9**, the roof drains on both Towers will require flow-controlled weirs. Based on the roof areas, an estimate of the number of roof drains required was completed. WATTS ACCUTROL weirs were used to determine the total discharge rates from the roof areas based on the number of drains. In addition, the total cumulative prism volumes on the roofs were calculated at a maximum permitted depth of 150mm. Additional information on the estimated 100-year volumes is provided in **Section 6.11**.

It is noted that the post-development flow to Richmond Road/ Forest St (28.1 L/s) is a few litres in excess of the pre-development flow to Richmond Road / Forest St (19.9 L/s), however the overall flow from the site following development, **69.2 L/s** is less than the allowable flow of 74.3 L/s with the two systems (from Richmond and Bond St storm sewers) joining immediately downstream at Croydon Ave and Richmond Road intersection. The proposed flow from the development is 29% of the pre-development flow, which results in a significant reduction in flow to the City sewers.

6.11 Flow Attenuation

Stormwater flow attenuation will be achieved by utilizing roof storage and a stormwater storage cistern in the underground parking structure. Using the allowable release rates, the Modified Rational Method was used to determine the 2-year, 5-year, and 100-year volumes that will occur for corresponding release rates.

Table D-12, **Table D-13** and **Table D-14** provide the storage volumes required on the roof and in the cistern in the underground parking structure to attenuate the controlled release rates. **Table D-11** summarizes the combined controlled and uncontrolled flows leaving the subject site. A summary of release rates, storage volume requirements, and provided storage volumes are identified in **Table 6-7** below and calculated in **Appendix D**.

Table 6-7 – Summary of Post-Development Storage

Area No.	Outlet	Release Rate (L/s)			Storage Required (m ³) (MRM)			Storage Provided (m ³)		Control Method
		2-yr	5-yr	100-yr	2-yr	5-yr	100-yr	Roof	Cistern	
Tower A Roof	Richmond / Forest	3.6	4.8	9.2	16.8	22.6	42.6	59.9		Flow Controlled Roof Drains with Weir (Set 3-1/4 open)
Surface - Uncontrolled		3.6	4.9	10.4						None
Tower B Roof		3.3	4.5	8.5	20.8	27.9	52.5	69.2		Flow Controlled Roof Drains with Weir (Set 3-1/4 open)
Surface - Controlled	Bond St	11.4	15.4	33.0	8.1	11.0	38.4		59.0	Pump Rate from Cistern
Surface - Uncontrolled		3.1	4.3	8.1						none
Totals =		24.9	33.8	69.2	45.7	61.5	133.5	129.1	59.0	

For the building roofs flow-controlled drains are necessary. An estimate of the controlled release rate and associated 100-year storage requirements was completed for the flat roof areas. **Table 6-7** provides the estimated 5-year and 100-year storage requirements for the entire site based on the Modified Rational Method. A combined 100-year storage of 133.5 m³ is required based on the allowable discharge rate of 74.3 L/s. The combination of controlled release from the roofs (6 drains on each roof with weir open 3-1/4) and cistern pump along with the uncontrolled flow result in an overall release rate of 69.2 L/s. Roof catchment areas and drains are shown on **Figure A-4** in **Appendix A**. For each tower (A & B), the penthouse roofs will drain onto the main roofs and be controlled through the controlled roof drains. **Table 6-8** below summarizes the estimated water depths on the roof during the 100-year event. Detailed calculations are provided in **Appendix D, Table D-15 and D-16**.

Table 6-8 – Summary of Ponding Storage Depths on Roof

Storm	Tower A	Tower B
2-year	Not calculated	Not calculated
5-year	94-100	103-111
100-year	121-138	131-139

The roof top terraces on Level 11 of each building will have roof drains uncontrolled to allow for sufficient drainage with no ponding of water. The uncontrolled flow is accounted for as shown in **Appendix D, Table D-15 and D-16**.

Refer to Mechanical Plans in **Appendix H** for cistern details.

6.12 Quality Control Measures

The site is located within the Pinecrest Creek subcatchment. As this area discharges to the Ottawa River the following summarizes the specific additional quality control requirements as per the Pinecrest / Westboro Criteria.

- Runoff Volume Reduction: On-site retention of 10 mm storm.
- Water Quality: 80% TSS removal.

As total suspended solids (TSS) removal efficiency of 80% is required it is proposed to provide an oil grit separator for quality control. Following discussions with the City, only the runoff from the driveway and surrounding pathways require treatment. This area is 0.0797 ha and has a peak flow rate of +/- 39.6 L/sec during the 100-yr storm. The Mechanical Design Drawing Details and sizing calculations for the quality control structure are provided in **Appendix H**.

To provide the necessary 10mm of volume reduction, the method outlined on Page 2 of Appendix B of the "SWM Guidelines for Pinecrest Creek/Westboro Area" report by JFSA was used. Approximately **37.3 m³** of the stormwater runoff from the 10 mm storm is required to be retained on site. A summary of the calculations from the methodology are shown below:

$$\begin{aligned} \text{Landscaped Area Runoff Volume} &= 0.088 \text{ ha} * (10\text{mm} - 4.67\text{mm}) * 10 \text{ m}^3/\text{ha} * \text{mm} \\ &= 4.7 \text{ m}^3 \end{aligned}$$

$$\begin{aligned} \text{Hard Surface Runoff Volume} &= 0.1207 \text{ ha} * (10\text{mm} - 1.57\text{mm}) * 10 \text{ m}^3/\text{ha} * \text{mm} \\ &= 9.5 \text{ m}^3 \end{aligned}$$

$$\begin{aligned} \text{Roof Area Runoff Volume} &= 0.2739 \text{ ha} * (10\text{mm} - 1.57\text{mm}) * 10 \text{ m}^3/\text{ha} * \text{mm} \\ &= 23.1 \text{ m}^3 \end{aligned}$$

4.7 m³ is required from the landscaped areas and will be captured and retained by amended topsoil. Runoff will be drained from the rooftop to the cistern located at the west side of Tower B and stored water will be used for irrigation and maintenance purposes. The required 10 mm storm volume for the two buildings and driveway area is +/- 32.6 m³. This volume of water will be collected from the roofs only, to allow runoff from the driveway area to be treated in the OGS located on the east side of the site. The remainder of the site, approximately 380 m², requiring approximately 3 m³ retention of 10 mm storm, is located along the perimeter of the site adjacent to Forest and Bond Street right of way. This area drains uncontrolled via surface flow to the municipal right of way. As per discussions with the City, the allowance for the uncontrolled flow from these areas is acceptable.

The potential for LID infiltration methods were reviewed but determined impractical due to the required extent of the development and underground parking garage.

7 Erosion & Sediment Control

During all construction activities, erosion and sedimentation shall be controlled by the following techniques:

- Filter cloth shall be installed between the frame and cover of all adjacent catch basins and catch basin manhole structures.
- Heavy duty silt fencing will be used to control runoff around the construction area. Silt fencing locations are identified on the site grading and erosion control plan.
- A mud mat will be installed at the construction entrance to help avoid mud from being transported to offsite roads.
- Visual inspection shall be completed daily on sediment control barriers and any damage repaired immediately. Care will be taken to prevent damage during construction operations.
- In some cases, barriers may be removed temporarily to accommodate the construction operations. The affected barriers will be reinstated at night when construction is completed.

- Sediment control devices will be cleaned of accumulated silt as required. The deposits will be disposed of as per the requirements of the contract.
- During the course of construction, if the engineer believes that additional prevention methods are required to control erosion and sedimentation, the contractor will install additional silt fences or other methods as required to the satisfaction of the engineer.
- Construction and maintenance requirements for erosion and sediment controls are to comply with Ontario Provincial Standard Specification (OPSS) OPSS 805 and City of Ottawa specifications.

8 Conclusions and Recommendations

This Functional Servicing & Stormwater Report outlines the rationale which will be used to service the proposed development. The following summarizes the servicing requirements for the site:

Water

- Two parallel 200mm watermains are proposed to service the residential Towers A and B, as the average day demands exceed 50 m³ per day, which is mandatory as per Section 4.31 of the WDG001.
- Two new hydrants are proposed; one located on Bond Street to meet spacing requirements of 90m for apartments and high-density areas as per WDG001 and the other located on Forest Street within 45m from the proposed fire department connections.
- The Required Fire Flows (RFFs) were estimated at **8,000 L/min** (133 L/sec) for Tower A, and **11,000 L/min** (183 L/sec) for Tower B. The total minimum available flows for firefighting purposes, based on the contribution from hydrants, was estimated at **22,800 L/min**.
- Based on hydraulic boundary conditions (HGL) provided by the City of Ottawa, a system pressure of **±52.2 psi** under peak hourly demands is anticipated at the proposed building. This exceeds the City's guideline of 20 psi.
- Domestic water booster and fire pump will be provided in the mechanical room at P1 parking level.

Sewage

- Estimated peak sewage flows of **6.76 L/sec** are anticipated. This exceeds the estimated current sewage flows of **0.44 L/sec** under existing conditions. An initial review of the downstream sanitary sewer system from the site and the Pinecrest Collector indicates minimum pipe capacity of 27 L/sec for a sewer run on Croydon Ave.

Stormwater

- For the stormwater system, the allowable capture rate from the entire site was calculated based on a runoff coefficient of 0.50, time of concentration of 10 minutes for a 5-year storm event. The allowable release rate for the entire site was calculated to be **78.8 L/sec**. Runoff in excess of this will be detained onsite for up to the 100-year storm.
- Two minor surface drainage areas will flow uncontrolled to the right-of-way. The 100-year peak flows from these two areas were accounted for (ie. subtracted) from the total runoff rate to establish the allowable rate.
- In order to meet the allowable release rate, a total retention volume of **±133.5 m³** is required.
- Runoff on the building roofs will be controlled using flow-controlled roof drains. For each roof-drain is equipped with WATTS ACCUTROL weirs and set at the OPEN position are proposed. Each drain having maximum discharge rate of 30 gpm at 150mm depth. A maximum discharge rate of **9.2 L/sec from Tower A** and **8.5 L/sec from Tower B** was established for the 100-year event.
- A total 100-year storage volume requirements on the roofs of Tower A and Tower B was estimated as **84.9 m³** (38.6 m³ and 46.3 m³ respectively), based on the above release rates, using the Modified Rational Method. The volumes available on the roofs are **108.4 m³** (48.3 m³ and 60.1 m³ respectively), therefore exceeding the required volumes.

- Runoff from the surface areas above the parking structure will be collected and detained in an underground stormwater chamber (cistern) located in the parking structure. The allowable discharge rate of **16.5 L/sec** (50% of 33 L/s) from the cistern will be met using an equal pump rate. The volume necessary to detain the 100-year event, is **59.0 m³**, based on using 50% of the allowable release rate as required by the City of Ottawa. The stormwater tank (cistern 2) will be sized to hold a minimum volume of approximately **59.0 m³**.
- Retention of the 10 mm storm is capture within the site through amended topsoil in the landscaped areas and a cistern located in the parking garage. The **32.6 m³** retained in cistern 1 will be reused on site for irrigation and maintenance.
- Quality control is provided via an oil grit separator within the underground parking garage collecting runoff from the driveway area and conveyed to cistern 2 prior to discharge to the municipal sewer. It is designed to remove 80% TSS from stormwater runoff from the driveway and surrounding area.

Erosion & Sediment Control

- Erosion and sediment control methods will be used during construction to limit erosion potential.

9 Legal Notification

This report was prepared by EXP Services Inc. for the account of 11061917 Canada Inc.

Any use which a third party makes of this report, or any reliance on or decisions to be made based on it, are the responsibility of such third parties. EXP Services Inc. accepts no responsibility for damages, if any, suffered by any third party as a result of decisions made or actions based on this project.

Appendix A - Figures

Figure A-1 - Pre-Development Drainage Areas

Figure A-2 - Post-Development Drainage Areas

Figure A-3 – Hydrant Location Plan

Figure A-4 – Roof Catchments

Figure A-5 – Fire Flow Distance Plan



FIGURE A-1 - PRE-DEVELOPMENT DRAINAGE AREA

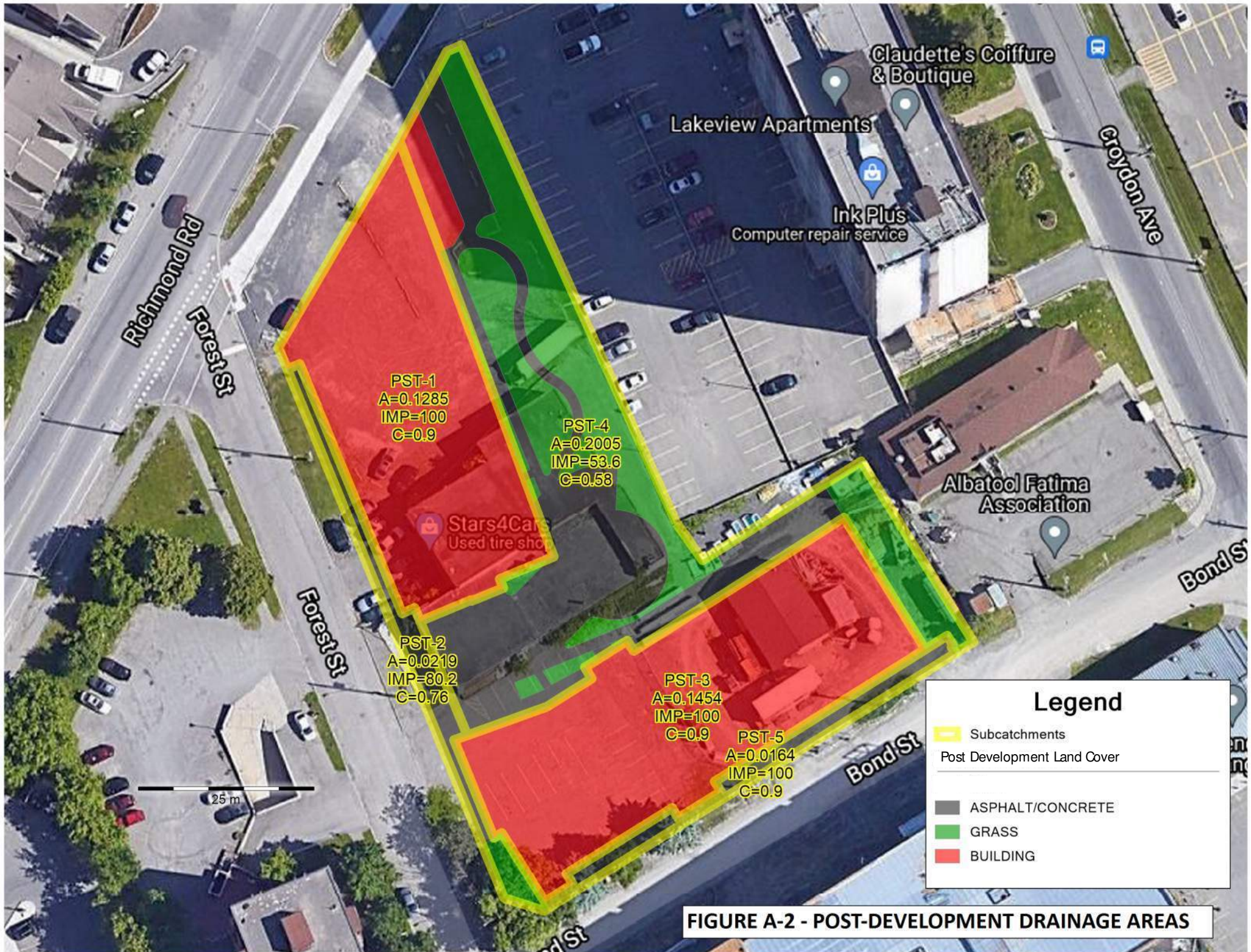

Legend

- Subcatchments
- Post Development Land Cover

- ASPHALT/CONCRETE
- GRASS
- BUILDING

FIGURE A-2 - POST-DEVELOPMENT DRAINAGE AREAS

Appendix B – Water Servicing Tables

Table B-1 – Water Demand Chart

Table B-2 – Fire Flow Requirements Based on Fire Underwriters Survey (FUS) – Tower A

Table B-3 – Fire Flow Requirements Based on Fire Underwriters Survey (FUS) – Tower B

Table B-4 – Available Fire Flows Based on Hydrant Spacing

Table B-5 – Estimated Water Pressure at Proposed Building



**Table B-1
Water Demand Chart**

Building	No. of Units										Total Pop	Residential Demands					Commercial					Total Demands in (L/sec)			
	Singles/Semis/Towns					Apartments						Avg Day Demand (L/day)	Max Day Peaking Factor	Max Hour Peaking Factor	Max Day Demand (L/day)	Peak Hourly Demand (L/day)	Area (ha)	Avg Demand (L/day)	Peaking Factors (x Avg Day)		Max Day Demand (L/day)	Peak Hour Demand (L/day)	Avg Day (L/s)	Max Day (L/s)	Peak Hour (L/s)
	Single Family	Semi	Duplex	Townhome	Bachelor	1-Bed Apt	1-Bed +Den Apt	2 Bed Apt	2-Bed +Den Apt	3 Bed Apt									Max Day	Peak Hour					
Tower A					11	13	102	42			264.6	92,610	2.5	2.2	231,525	509,355	0.0338	946	1.5	1.8	1419.6	2555.3	1.08	2.70	5.92
Tower B					23	12	145	43			342.3	119,805	2.5	2.2	299,513	658,928	0.0092	257.6	1.5	1.8	386.4	463.7	1.39	3.47	7.63
Totals =					34	25	247	85			606.9	212,415			531,038	1,168,283	0.0430	1,204			1,806.0	3,019.0	2.47	6.17	13.56
Unit Densities												Project:													
Persons/Unit												365 Forest Street													
Residential												Designed: J Diaz, P.Eng. Location: Ottawa, Ontario													
Singles 3.4 Residential Consumption (L/pers/day) = 350												Checked: B. Thomas, P.Eng.													
Semi-Detached 2.7 Max Day Peaking Factor (* avg day) = 2.5												File Reference: 252570 Storm - Roof drain Design Sheet D15, Nov 2021 Tower A.xlsx													
Duplex 2.3 Peak Hour Factor (* max day) = 2.2												Page No: 1 of 1													
Townhome 2.7																									
Bachelor Apt Unit 1.4																									
1-Bed Apt Unit 1.4																									
1-Bed + Den Apt Unit 1.4																									
2-Bed Apt Unit 2.1																									
2-Bed + Den Apt Unit 2.1																									
3-Bed Apt Unit 3.1																									
Industrial/Commercial/Institutional Water Consumption																									
Light Industrial (L/gross ha/day) = 35,000																									
Heavy Industrial (L/gross ha/day) = 55,000																									
Commer/Instit (L/gross ha/day) = 28,000																									
Max Day Peaking Factor (* avg day) = 1.5																									
Peak Hour Factor (* max day) = 1.8																									

TABLE B-2
FIRE FLOW REQUIREMENTS BASED ON FIRE UNDERWRITERS SURVEY(FUS) 1999 FOR TOWER A



An estimate of the Fire Flow required for a given fire area may be estimated by:

$$F = 220 * C * \text{SQRT}(A)$$

where: F = required fire flow in litres per minute
 A = total floor area in m² (including all storeys, but excluding basements at least 50% below grade)
 C = coefficient related to the type of construction

Task	Options	Multiplier	Input			Value Used	Fire Flow Total (L/min)
Choose Building Frame (C)	Wood Frame	1.5	Non-combustible Construction			0.8	
	Ordinary Construction	1					
	Non-combustible Construction	0.8					
	Fire Resisive Construction	0.6					
Input Building Floor Areas (A)			Area	% Used	Area Used	2 largest adjoining floors+ 50% of floors above (up to eight)	
	Floor 12		1,186	0%	0		
	Floor 11		1,193	0%	0		
	Floor 10		1,193	50%	597		
	Floor 9		1,193	50%	597		
	Floor 8		1,193	50%	597		
	Floor 7		1,158	50%	579		
	Floor 6		1,210	50%	605		
	Floor 5		1,210	50%	605		
	Floor 4		1,210	50%	605		
	Floor 3		1,210	50%	605		
	Floor 2		1,193	100%	1,193		
	Floor 1 (Ground)		1,193	100%	1,193		
Basement (At least 50% below grade, not included)			0				
Fire Flow (F)	F = 220 * C * SQRT(A)						14,908
Fire Flow (F)	Rounded to nearest 1,000						15,000

Reductions/Increases Due to Factors Effecting Burning

Task	Options	Multiplier	Input			Value Used	Fire Flow Change (L/min)	Fire Flow Total (L/min)										
Choose Combustibility of Building Contents	Non-combustible	-25%	Limited Combustible			-15%	-2,250	12,750										
	Limited Combustible	-15%																
	Combustible	0%																
	Free Burning	15%																
	Rapid Burning	25%																
Choose Reduction Due to Sprinkler System	Adequate Sprinkler Conforms to NFPA13	-30%	Adequate Sprinkler Conforms to NFPA13			-30%	-3,825	8,925										
	No Sprinkler	0%																
	Standard Water Supply for Fire Department Hose Line and for Sprinkler System	-10%	Standard Water Supply for Fire Department Hose Line and for Sprinkler System			-10%	-1,275	7,650										
	Not Standard Water Supply or Unavailable	0%																
	Fully Supervised Sprinkler System	-10%	Fully Supervised Sprinkler System			-10%	-1,275	6,375										
Choose Structure Exposure Distance	Exposures	Separation Dist (m)	Cond	Separation Condition	Exposed Wall type	Exposed Wall Length				Total Charge (%)	Total Exposure Charge (L/min)							
						Length (m)	No of Storeys	Lenth-height Factor	Sub-Condition									
						Side 1 (west)	22	4	20.1 to 30				Type B	43	9	387	4E	10%
						Side 2 (east)	46	6	> 45.1				Type B	46	19	874	6	0%
						Front (north)	39	5	30.1 to 45				Type B	62	2	124	5E	5%
Back (south)	15	3	10.1 to 20	Type B	15	12	30	3A	10%									
Obtain Required Fire Flow	Total Required Fire Flow, Rounded to the Nearest 1,000 L/min =										8,000							
	Total Required Fire Flow, L/s =										133							

Exposure Charges for Exposing Walls of Wood Frame Construction (from Table G5)

- Type A Wood-Frame or non-combustible
- Type B Ordinary or fire-resisive with unprotected openings
- Type C Ordinary or fire-resisive with semi-protected openings
- Type D Ordinary or fire-resisive with blank wall

Conditons for Separation

Separation Dist	Condition
0m to 3m	1
3.1m to 10m	2
10.1m to 20m	3
20.1m to 30m	4
30.1m to 45m	5
> 45.1m	6

**TABLE B-3
FIRE FLOW REQUIREMENTS BASED ON FIRE UNDERWRITERS SURVEY(FUS) 1999 FOR**

TOWER B



An estimate of the Fire Flow required for a given fire area may be estimated by:

$$F = 220 * C * \text{SQRT}(A)$$

where:

- F = required fire flow in litres per minute
- A = total floor area in m² (including all storeys, but excluding basements at least 50% below grade)
- C = coefficient related to the type of construction

Task	Options	Multiplier	Input			Value Used	Fire Flow Total (L/min)
Choose Building Frame (C)	Wood Frame	1.5	Non-combustible Construction			0.8	
	Ordinary Construction	1					
	Non-combustible Construction	0.8					
	Fire Resistive Construction	0.6					
Input Building Floor Areas (A)			Area	% Used	Area Used	2 largest adjoining floors+ 50% of floors above (up to eight)	
	Floor 12		1,507	50%	754		
	Floor 11		1,518	50%	759		
	Floor 10		1,518	50%	759		
	Floor 9		1,518	50%	759		
	Floor 8		1,518	50%	759		
	Floor 7		1,468	50%	734		
	Floor 6		1,652	50%	826		
	Floor 5		1,652	50%	826		
	Floor 4		1,652	100%	1,652		
	Floor 3		1,652	100%	1,652		
	Floor 2		1,500	0%	0		
	Floor 1 (Ground)		1,470	0%	0		
	Basement (At least 50% below grade, not included)		0				
Fire Flow (F)	F = 220 * C * SQRT(A)						17,136
Fire Flow (F)	Rounded to nearest 1,000						17,000

Reductions/Increases Due to Factors Effecting Burning

Task	Options	Multiplier	Input					Value Used	Fire Flow Change (L/min)	Fire Flow Total (L/min)				
Choose Combustibility of Building Contents	Non-combustible	-25%	Limited Combustible					-15%	-2,550	14,450				
	Limited Combustible	-15%												
	Combustible	0%												
	Free Burning	15%												
	Rapid Burning	25%												
Choose Reduction Due to Sprinkler System	Adequate Sprinkler Conforms to NFPA13	-30%	Standard Water Supply for Fire Department Hose Line and for Sprinkler System					-30%	-4,335	10,115				
	No Sprinkler	0%												
	Standard Water Supply for Fire Department Hose Line and for Sprinkler System	-10%												
	Not Standard Water Supply or Unavailable	0%												
	Fully Supervised Sprinkler System	-10%												
Not Fully Supervised or N/A	0%	Fully Supervised Sprinkler System					-10%	-1,445	7,225					
Choose Structure Exposure Distance	Exposures	Separation Dist (m)	Cond	Separation Condition	Exposed Wall type	Exposed Wall Length				Total Charge (%)	Total Exposure Charge (L/min)			
	Side 1 (west)	23	4	20.1 to 30	Type B	Length (m)	No of Storeys	Lenth-height Factor	Sub-Condition				Charge (%)	
	Side 2 (east)	7	2	3.1 to 10	Type B	11	1	11	2A				15%	
	Front (north)	15	3	10.1 to 20	Type B	22	12	264	3E				15%	
	Back (south)	24	4	20.1 to 30	Type B	69	5	30	4A				6%	
Obtain Required Fire Flow	Total Required Fire Flow, Rounded to the Nearest 1,000 L/min =										11,000	Total Required Fire Flow, L/s =		183

Exposure Charges for Exposing Walls of Wood Frame Constructon (from Table G5)

- Type A Wood-Frame or non-combustible
- Type B Ordinary or fire-resistive with unprotected openings
- Type C Ordinary or fire-resistive with semi-protected openings
- Type D Ordinary or fire-resistive with blank wall

Conditions for Separation

Separation Dist	Condition
0m to 3m	1
3.1m to 10m	2
10.1m to 20m	3
20.1m to 30m	4
30.1m to 45m	5
> 45.1m	6

TABLE B-4**AVAILABLE FIRE FLOWS BASED ON HYDRANT SPACING**

Hydrant #	Location	Tower A		Tower B	
		¹ Distance (m)	² Fire Flow Contribution (L/min)	Distance (m)	Fire Flow Contribution (L/min)
New FH-1	Forest Street	8	5,700	32	5,700
New FH-2	Bond Street	82	3,800	56	5,700
360024H013	Forest Steet at Richmond Rd	37	5,700	62	5,700
360024H038	Forest Steet at Carling Ave	116	3,800	98	3,800
360024H039	Forest Steet at Carling Ave	161	0	144	3,800
360024HP120	Forest Steet near Bond St	76	3,800	52	5,700
360024H041	Bond Street at Croydon Ave	170	0	145	3,800
Total (L/min)			22,800		34,200
FUS RFF in L/min or (L/sec)			8,000 (133)		11,000 (183)
Meets Requirement (Yes/No)			Yes		Yes
Notes:					
¹ Distance is measured along a road or fire route.					
² Fire Flow Contribution for Class AA Hydrant from Table 1 of Appendix I, ISTB-2018-02					

TABLE B-5

ESTIMATED WATER PRESSURE AT PROPOSED BUILDING

Description	From	To	Demand (L/sec)	Pipe Length (m)	Pipe Dia (mm)	Dia (m)	Q (m3/sec)	Area (m2)	C	Vel (m/s)	Slope of HGL (m/m)	Head Loss (m)	Elev From (m)	Elev To (m)	*Elev Diff (m)	Pressure From (kPa (psi))	Pressure To (kPa (psi))	Pressure Drop (psi)
Avg Day Conditions																		
Single 200mm watermain	Main	Building	2.5	11 m	204	0.204	0.0025	0.032685	110	0.0756	6E-05	0.0007	74.85	71.80	3.1	328.1 (47.6)	358.1 (51.9)	-4.3
Double 200mm watermain	Main	Building	1.2	11 m	204	0.204	0.0012	0.032685	110	0.0378	1.7E-05	0.0002	74.85	71.80	3.1	328.1 (47.6)	358.1 (51.9)	-4.3
Max Day Conditions																		
Single 200mm watermain	Main	Building	6.2	11 m	204	0.204	0.0062	0.032685	110	0.1885	0.00033	0.0036	74.85	71.80	3.1	397.8 (57.7)	427.7 (62.0)	-4.3
Double 200mm watermain	Main	Building	3.1	11 m	204	0.204	0.0031	0.032685	110	0.0942	9.1E-05	0.001	74.85	71.80	3.1	397.8 (57.7)	427.7 (62.0)	-4.3
Peak Hour Conditions																		
Single 200mm watermain	Main	Building	13.6	11 m	204	0.204	0.0136	0.032685	110	0.4146	0.00141	0.0155	74.85	71.80	3.1	330.1 (47.9)	359.9 (52.2)	-4.3
Double 200mm watermain	Main	Building	6.8	11 m	204	0.204	0.0068	0.032685	110	0.2073	0.00039	0.0043	74.85	71.80	3.1	330.1 (47.9)	360.0 (52.2)	-4.3
Max Day Plus Fireflow Conditions																		
Single 200mm watermain	Main	Building	189.2	11 m	204	0.204	0.1892	0.032685	110	5.7873	0.18628	2.0491	74.85	71.80	3.1	337.0 (48.9)	346.8 (50.3)	-1.4
Double 200mm watermain	Main	Building	94.6	11 m	204	0.204	0.0946	0.032685	110	2.8937	0.0516	0.5676	74.85	71.80	3.1	337.0 (48.9)	361.3 (52.4)	-3.5
Peak Hour Conditions (Review of 150mm)																		
Single 150mm watermain	Main	Building	13.6	11 m	155	0.155	0.0136	0.018869	110	0.7181	0.00538	0.0592	74.85	71.80	3.1	330.1 (47.9)	359.4 (52.1)	-4.3
Double 150mm watermain	Main	Building	6.8	11 m	155	0.155	0.0068	0.018869	110	0.3591	0.00149	0.0164	74.85	71.80	3.1	330.1 (47.9)	359.9 (52.2)	-4.3
Max Day Plus Fireflow (Review of 150mm)																		
Single 150mm watermain	Main	Building	189.2	11 m	155	0.155	0.1892	0.018869	110	10.025	0.70982	7.808	74.85	71.80	3.1	337.0 (48.9)	290.3 (42.1)	6.8
Double 150mm watermain	Main	Building	94.6	11 m	155	0.155	0.0946	0.018869	110	5.0124	0.19663	2.1629	74.85	71.80	3.1	337.0 (48.9)	345.7 (50.1)	-1.3
Water Demand Info																		
Average Demand =	2.47	L/sec														11 m		
Max Day Demand =	6.16	L/sec														110		
Peak Hr Demand =	13.55	L/sec																
Fireflow Requirement =	183	L/sec																
Max Day Plus FF Demand =	189.2	L/sec																
Boundary Condition																		
HGL (m)	<u>Min HGL</u>	<u>Max HGL</u>	<u>Peak Hr</u>	<u>Max Day + Fireflow</u>														
	108.3	115.4	108.5	109.2	(From City of Ottawa)													
Approx Ground Elev (m) =	74.85	74.85	74.85	74.85														
Approx Mech Room FF Elev (m) =	71.80	71.80	71.80	71.80														
Pressure (m) =	33.45	40.55	33.65	34.35														
Pressure (Pa) =	328,145	397,796	330,107	336,974														
Pressure (psi) =	47.6	57.7	47.9	48.9														

Pipe Lengths
 From watermain to building =
 Hazen Williams C Factor for Friction Loss in Pipe, C=

11 m
 110

Appendix C – Sanitary Servicing Tables

Table C-6 – Sanitary Sewer Design Sheet



**Table C-6
SANITARY SEWER CALCULATION SHEET**

LOCATION			RESIDENTIAL AREAS AND POPULAITONS											COMMERCIAL				INFILTRATION			SEWER DATA																						
Street	U/S MH	D/S MH	Area (ha)	NUMBER OF UNITS						POPULATION		Peak Factor	Peak Flow (L/sec)	AREA (ha)		Peak Factor	Peak Flow (L/sec)	AREA (ha)		INFILT FLOW (L/s)	TOTAL FLOW (L/s)	Nom Dia (mm)	Actual Dia (mm)	Slope (%)	Length (m)	Capacity (L/sec)	Q/Q _{CAP} (%)	Full Velocity (m/s)															
				Single	Semi	1-Bed Apt.	1-Bed + Den Apt.	2-Bed Apt.	2-Bed + Den Apt.	3-Bed Apt.	INDIV			ACCU	INDIV			ACCU	INDIV										ACCU														
Forest	Tower A	MH 200	0.2717			24	102	42			264.6	264.6	4.00	3.43	0.0256	0.0256	1.0	0.008	0.2717	0.2717	0.09	3.53	250	251.46	2.0	6.1	85.4	4%	1.72														
	Tower B	MH 200	0.2717			35	145	43			342.3	342.3	4.00	4.44	0.0092	0.0092	1.0	0.003	0.2717	0.2717	0.09	4.53	250	251.46	2.0	1.0	85.4	5%	1.72														
		MH 200	MH 201								606.9	606.9	3.34	6.57		0.0348	1.0	0.011		0.5434	0.18	6.76	250	251.46	2.0	9.7	85.4	8%	1.72														
			0.543			59	247	85			607																																
Residential Avg. Daily Flow, q (L/p/day) = 280 Commercial Avg. Daily Flow (L/gross ha/day) = 28,000 or L/gross ha/sec = 0.324 Institutional Avg. Daily Flow (L/s/ha) = 28,000 or L/gross ha/sec = 0.324 Light Industrial Flow (L/gross ha/day) = 35,000 or L/gross ha/sec = 0.4051 Light Industrial Flow (L/gross ha/day) = 55,000 or L/gross ha/sec = 0.637																		Commercial Peak Factor = 1.5 (when area >20%) = 1.0 (when area <20%) Institutional Peak Factor = 1.5 (when area >20%) = 1.0 (when area <20%) Residential Correction Factor, K = 0.80 Manning N = 0.013 Peak extraneous flow, I (L/s/ha) : 0.33 (Total I/I)						Peak Population Flow, (L/sec) = P*q*M/86.4 Peak Extraneous Flow, (L/sec) = I*Ac Residential Peaking Factor, M = 1 + (14/(4+P^0.5)) * K Sewer Capacity, Qcap (L/sec) = 1/N S ^{1/2} R ^{2/3} A _c				Unit Type Ppu Singles = 3.4 Semi-Detached = 2.7 1-bed Apt = 1.4 1-bed + Den Apt = 1.4 2-bed Apt. Unit = 2.1 2-bed + Den Apt = 2.1 3-bed Apt. Unit = 3.1				Designed: J. Diaz, P.Eng.		Project: 365 Forest Street		Checked: B. Thomas, P.Eng.		Location: Ottawa, Ontario		File Reference: 252570 Sanitary - Sewer Design Sheet, Oct 18, 2021.xlsx		Page No: 1 of 1	

Appendix D – Stormwater Servicing Tables

Table D-7 – Average Runoff Coefficients for Pre-Development

Table D-8 – Estimation of Pre-Development Peak Flows

Table D-9 – Estimation of Allowable Peak Flows (Based on Max C=0.50 with Tc=10mins)

Table D-10 – Average Runoff Coefficients for Post-Development

Table D-11 – Summary of Post-Development Peak Flows (Uncontrolled and Controlled)

Table D-12 – Storage Volumes for 2-year, 5-year and 100-Year Storms (Area PST-1)

Table D-13 – Storage Volumes for 2-year, 5-year and 100-Year Storms (Area PST-3)

Table D-14 – Storage Volumes for 2-year, 5-year and 100-Year Storms (Area PST-4)

Table D-15 –Roof Design Sheet - Tower A

Table D-16 – Roof Design Sheet - Tower B

Table D-7 AVERAGE RUNOFF COEFFICIENTS FOR PRE-DEVELOPMENT

Runoff Coefficients									
		$C_{GRAVEL} =$	<u>0.725</u>	$C_{ROOF} =$	<u>0.90</u>	$C_{GRASS} =$	<u>0.20</u>	$C_{Asphalt} =$	<u>0.900</u>
Area No.	Gravel Areas (m ²)	A * C _{ASPH}	Roof Areas (m ²)	A * C _{ROOF}	Grassed Areas (m ²)	A * C _{GRASS}	Sum AC	Total Area (m ²)	C _{AVG} (see note)
PRE-1								1375.0	0.74
PRE-2								3751.0	0.76
Notes									
1) Cavg derived with area-weighting command in PCSWMM									

Table D-8 ESTIMATION OF PRE-DEVELOPMENT PEAK FLOWS

Catchment No.	Area (ha)	Outlet Location	Time of Conc, Tc (min)	Storm = 2 yr			Storm = 5 yr			Storm = 100 yr		
				I ₂ (mm/hr)	Cavg	Q _{2PRE} (L/sec)	I ₅ (mm/hr)	Cavg	Q _{5PRE} (L/sec)	I ₁₀₀ (mm/hr)	Cavg	Q _{100PRE} (L/sec)
PRE-1	0.1375	To Richmond / Forest	10.0	76.81	0.74	21.7	104.29	0.74	29.5	178.56	0.93	63.1
PRE-2	0.3751	To Bond St	10.0	76.81	0.76	60.9	104.29	0.76	82.6	178.56	0.95	176.9
Totals		0.5126				82.6			112.1			240.0
Notes												
1) Intensity, I = 732.951/(Tc+6.199) ^{0.810} (2-year, City of Ottawa)												
2) Intensity, I = 998.071/(Tc+6.035) ^{0.814} (5-year, City of Ottawa)												
3) Intensity, I = 1735.688/(Tc+6.014) ^{0.820} (100-year, City of Ottawa)												
4) Cavg for 100-year is increased by 25% to a maximum of 1.0												

Table D-9 ESTIMATION OF ALLOWABLE PEAK FLOWS (Based on Max C=0.50 with Tc=10mins)

Area (onsite)	Area (ha)	Time of Conc, Tc (min)	Storm = 2 yr			Storm = 5 yr		
			I ₅ (mm/hr)	Cavg	Q _{SALLOW} (L/sec)	I ₅ (mm/hr)	Cavg	Q _{SALLOW} (L/sec)
PRE-1	0.1375	10	76.81	0.50	14.7	104.29	0.50	19.9
PRE-2	0.3751	10	76.81	0.50	40.0	104.29	0.50	54.4
Totals		0.5126			54.7			74.3
Notes								
1) Allowable Capture Rate is based on 5-year storm at Tc=10 minutes.								
2) Intensity, I ₅ = 998.071/(Tc+6.035) ^{0.814} (5-year, City of Ottawa)								

Allowable Discharge (based on 5-yr storm)

Table D-10 AVERAGE RUNOFF COEFFICIENTS FOR POST-DEVELOPMENT

Runoff Coefficients C _{ASPH/CONC} = <u>0.90</u> C _{ROOF} = <u>0.90</u> C _{GRASS} = <u>0.20</u>											
Area No.	Outlet Location	Asphalt & Conc Areas (m ²)	A * C _{ASPH}	Roof Areas (m ²)	A * C _{ROOF}	Grassed Areas (m ²)	A * C _{GRASS}	Sum AC	Total Area (m ²)	C _{AVG} (see note)	Comment
PST-1	To Richmond / Forest								1285	0.90	Tower A Roof
PST-2									219	0.76	Surface - Uncontrolled
PST-3									1454	0.90	Tower B Roof
PST-4	To Bond St								2005	0.58	Surface - Controlled
PST-5									164	0.90	Surface - Uncontrolled
Totals									5,127		
Notes											
1) Cavg derived with area-weighting command in PCSWMM											

Table D-11 SUMMARY OF POST-DEVELOPMENT PEAK FLOWS (Uncontrolled and Controlled)

Area No	Area (ha)	Time of Conc, Tc (min)	Storm = 2 yr				Storm = 5 yr				Storm = 100 yr				Outlet	Comments
			C _{AVG}	I ₂ (mm/hr)	Q (L/sec)	Q _{CAP} (L/sec)	C _{AVG}	I ₅ (mm/hr)	Q (L/sec)	Q _{CAP} (L/sec)	C _{AVG}	I ₁₀₀ (mm/hr)	Q (L/sec)	Q _{CAP} (L/sec)		
PST-1	0.1285	10	0.90	76.81	24.6	(3.6)	0.90	104.19	33.4	(4.8)	1.00	178.56	63.8	(9.2)	To Richmond / Forest	Tower A Roof
PST-2	0.0219	10	0.76	76.81	3.6	(3.6)	0.76	104.19	4.8	4.8	0.95	178.56	10.3	10.3		Surface - Uncontrolled
PST-3	0.1454	10	0.90	76.81	27.9	(3.3)	0.90	104.19	37.9	(4.5)	1.00	178.56	72.2	(8.5)		Tower B Roof
PST-4	0.2005	10	0.58	76.81	24.8	(11.4)	0.58	104.19	33.7	(15.4)	0.73	178.56	72.2	(33.0)	To Bond St	Surface - Controlled
PST-5	0.0164	10	0.90	76.81	3.1	3.1	0.90	104.19	4.3	4.3	1.00	178.56	8.1	8.1		Surface - Uncontrolled
Totals		0.5127			84.1	24.9		114.1	33.8			226.6	69.1			
Notes																
2-yr Storm Intensity, I = 732.951/(Tc+6.199)^0.810 (City of Ottawa)																
5-yr Storm Intensity, I = 998.071/(Tc+6.035)^0.814 (City of Ottawa)																
100-yr Storm Intensity, I = 1735.688/(Tc+6.014)^0.820 (City of Ottawa)																
Time of Concentration (min), Tc = 10																
For Flows under column Qcap which are shown in brackets (0.0) , denotes flows that are controlled																

Table D-12 Storage Volumes for 2-year, 5-Year and 100-Year Storms Area: PST-1

Area No: <u>PST-1</u> $C_{AVG} = \frac{0.90}{(2\text{-yr})}$ $C_{AVG} = \frac{0.90}{(5\text{-yr})}$ $C_{AVG} = \frac{1.00}{(100\text{-yr, Max 1.0})}$ Time Interval = <u>5.00</u> (mins) Drainage Area = <u>0.1285</u> (hectares)															
Duration (min)	Release Rate = $\frac{3.6}{(L/sec)}$ Return Period = $\frac{2}{(years)}$ IDF Parameters, A = $\frac{732.951}{(I = A/(T_c+C))}$, B = $\frac{0.810}{}$, C = $\frac{6.199}{}$					Release Rate = $\frac{4.8}{(L/sec)}$ Return Period = $\frac{5}{(years)}$ IDF Parameters, A = $\frac{998.071}{(I = A/(T_c+C))}$, B = $\frac{0.814}{}$, C = $\frac{6.053}{}$					Release Rate = $\frac{9.2}{(L/sec)}$ Return Period = $\frac{100}{(years)}$ IDF Parameters, A = $\frac{1735.688}{(I = A/(T_c+C))}$, B = $\frac{0.820}{}$, C = $\frac{6.014}{}$				
	Rainfall Intensity, I (mm/hr)	Peak Flow (L/sec)	Release Rate (L/sec)	Storage Rate (L/sec)	Storage (m ³)	Rainfall Intensity, I (mm/hr)	Peak Flow (L/sec)	Release Rate (L/sec)	Storage Rate (L/sec)	Storage (m ³)	Rainfall Intensity, I (mm/hr)	Peak Flow (L/sec)	Release Rate (L/sec)	Storage Rate (L/sec)	Storage (m ³)
0	167.2	53.6	3.55	50.1	0.00	230.5	73.9	4.821	69.1	0.00	398.6	142.4	9.200	133.2	0.00
5	103.6	33.2	3.55	29.7	8.90	141.2	45.3	4.821	40.5	12.14	242.7	86.7	9.200	77.5	23.25
10	76.8	24.6	3.55	21.1	12.65	104.2	33.4	4.821	28.6	17.16	178.6	63.8	9.200	54.6	32.75
15	61.8	19.8	3.55	16.3	14.63	83.6	26.8	4.821	22.0	19.79	142.9	51.0	9.200	41.8	37.66
20	52.0	16.7	3.55	13.1	15.77	70.3	22.5	4.821	17.7	21.26	120.0	42.8	9.200	33.6	40.38
25	45.2	14.5	3.55	10.9	16.40	60.9	19.5	4.821	14.7	22.07	103.8	37.1	9.200	27.9	41.85
30	40.0	12.8	3.55	9.3	16.73	53.9	17.3	4.821	12.5	22.46	91.9	32.8	9.200	23.6	42.51
35	36.1	11.6	3.55	8.0	16.83	48.5	15.6	4.821	10.7	22.56	82.6	29.5	9.200	20.3	42.63
40	32.9	10.5	3.55	7.0	16.77	44.2	14.2	4.821	9.4	22.45	75.1	26.8	9.200	17.6	42.35
45	30.2	9.7	3.55	6.1	16.60	40.6	13.0	4.821	8.2	22.17	69.1	24.7	9.200	15.5	41.76
50	28.0	9.0	3.55	5.4	16.33	37.7	12.1	4.821	7.3	21.77	64.0	22.8	9.200	13.6	40.94
55	26.2	8.4	3.55	4.8	15.98	35.1	11.3	4.821	6.4	21.27	59.6	21.3	9.200	12.1	39.93
60	24.6	7.9	3.55	4.3	15.57	32.9	10.6	4.821	5.7	20.69	55.9	20.0	9.200	10.8	38.76
65	23.2	7.4	3.55	3.9	15.10	31.0	10.0	4.821	5.1	20.04	52.6	18.8	9.200	9.6	37.47
70	21.9	7.0	3.55	3.5	14.60	29.4	9.4	4.821	4.6	19.33	49.8	17.8	9.200	8.6	36.06
75	20.8	6.7	3.55	3.1	14.05	27.9	8.9	4.821	4.1	18.57	47.3	16.9	9.200	7.7	34.56
80	19.8	6.4	3.55	2.8	13.48	26.6	8.5	4.821	3.7	17.76	45.0	16.1	9.200	6.9	32.99
85	18.9	6.1	3.55	2.5	12.87	25.4	8.1	4.821	3.3	16.92	43.0	15.3	9.200	6.1	31.34
90	18.1	5.8	3.55	2.3	12.24	24.3	7.8	4.821	3.0	16.04	41.1	14.7	9.200	5.5	29.62
95	17.4	5.6	3.55	2.0	11.58	23.3	7.5	4.821	2.7	15.14	39.4	14.1	9.200	4.9	27.86
100	16.7	5.4	3.55	1.8	10.91	22.4	7.2	4.821	2.4	14.20	37.9	13.5	9.200	4.3	26.04
Max =				16.83					22.56					42.63	

Notes

- 1) Peak flow is equal to the product of $2.78 \times C \times I \times A$
- 2) Rainfall Intensity, $I = A/(T_c+C)^B$
- 3) Release Rate = Min (Release Rate, Peak Flow)
- 4) Storage Rate = Peak Flow - Release Rate
- 5) Storage = Duration x Storage Rate
- 6) Maximum Storage = Max Storage Over Duration
- 7) Parameters a,b,c are for City of Ottawa

Table D-13 Storage Volumes for 2-year, 5-Year and 100-Year Storms Area: PST-3

Area No: PST-3 $C_{AVG} = 0.90$ (2-yr) $C_{AVG} = 0.90$ (5-yr) $C_{AVG} = 1.00$ (100-yr, Max 1.0) Time Interval = 5.00 (mins) Drainage Area = 0.1454 (hectares)															
Duration (min)	Release Rate = <u>3.3</u> (L/sec) Return Period = <u>2</u> (years) IDF Parameters, A = <u>732.951</u> , B = <u>0.810</u> ($I = A/(T_c+C)$), C = <u>6.199</u>					Release Rate = <u>4.5</u> (L/sec) Return Period = <u>5</u> (years) IDF Parameters, A = <u>998.071</u> , B = <u>0.814</u> ($I = A/(T_c+C)$), C = <u>6.053</u>					Release Rate = <u>8.5</u> (L/sec) Return Period = <u>100</u> (years) IDF Parameters, A = <u>1735.688</u> , B = <u>0.820</u> ($I = A/(T_c+C)$), C = <u>6.014</u>				
	Rainfall Intensity, I (mm/hr)	Peak Flow (L/sec)	Release Rate (L/sec)	Storage Rate (L/sec)	Storage (m ³)	Rainfall Intensity, I (mm/hr)	Peak Flow (L/sec)	Release Rate (L/sec)	Storage Rate (L/sec)	Storage (m ³)	Rainfall Intensity, I (mm/hr)	Peak Flow (L/sec)	Release Rate (L/sec)	Storage Rate (L/sec)	Storage (m ³)
0	167.2	60.8	3.29	57.5	0.00	230.5	83.8	4.464	79.4	0.00	398.6	161.1	8.500	152.6	0.00
5	103.6	37.7	3.29	34.4	10.32	141.2	51.4	4.464	46.9	14.07	242.7	98.1	8.500	89.6	26.88
10	76.8	27.9	3.29	24.7	14.79	104.2	37.9	4.464	33.4	20.06	178.6	72.2	8.500	63.7	38.21
15	61.8	22.5	3.29	19.2	17.26	83.6	30.4	4.464	25.9	23.34	142.9	57.8	8.500	49.3	44.33
20	52.0	18.9	3.29	15.6	18.77	70.3	25.6	4.464	21.1	25.31	120.0	48.5	8.500	40.0	47.98
25	45.2	16.4	3.29	13.1	19.71	60.9	22.2	4.464	17.7	26.53	103.8	42.0	8.500	33.5	50.21
30	40.0	14.6	3.29	11.3	20.30	53.9	19.6	4.464	15.2	27.28	91.9	37.1	8.500	28.6	51.54
35	36.1	13.1	3.29	9.8	20.64	48.5	17.7	4.464	13.2	27.69	82.6	33.4	8.500	24.9	52.25
40	32.9	12.0	3.29	8.7	20.80	44.2	16.1	4.464	11.6	27.86	75.1	30.4	8.500	21.9	52.50
45	30.2	11.0	3.29	7.7	20.82	40.6	14.8	4.464	10.3	27.85	69.1	27.9	8.500	19.4	52.41
50	28.0	10.2	3.29	6.9	20.73	37.7	13.7	4.464	9.2	27.70	64.0	25.9	8.500	17.4	52.05
55	26.2	9.5	3.29	6.2	20.56	35.1	12.8	4.464	8.3	27.43	59.6	24.1	8.500	15.6	51.48
60	24.6	8.9	3.29	5.6	20.32	32.9	12.0	4.464	7.5	27.07	55.9	22.6	8.500	14.1	50.74
65	23.2	8.4	3.29	5.1	20.01	31.0	11.3	4.464	6.8	26.63	52.6	21.3	8.500	12.8	49.84
70	21.9	8.0	3.29	4.7	19.66	29.4	10.7	4.464	6.2	26.13	49.8	20.1	8.500	11.6	48.83
75	20.8	7.6	3.29	4.3	19.26	27.9	10.1	4.464	5.7	25.57	47.3	19.1	8.500	10.6	47.71
80	19.8	7.2	3.29	3.9	18.83	26.6	9.7	4.464	5.2	24.96	45.0	18.2	8.500	9.7	46.49
85	18.9	6.9	3.29	3.6	18.37	25.4	9.2	4.464	4.8	24.30	43.0	17.4	8.500	8.9	45.20
90	18.1	6.6	3.29	3.3	17.87	24.3	8.8	4.464	4.4	23.61	41.1	16.6	8.500	8.1	43.83
95	17.4	6.3	3.29	3.0	17.35	23.3	8.5	4.464	4.0	22.88	39.4	15.9	8.500	7.4	42.41
100	16.7	6.1	3.29	2.8	16.81	22.4	8.2	4.464	3.7	22.13	37.9	15.3	8.500	6.8	40.93
Max =	20.82					27.86					52.50				
Notes 1) Peak flow is equal to the product of $2.78 \times C \times I \times A$ 2) Rainfall Intensity, $I = A/(T_c+C)^B$ 3) Release Rate = Min (Release Rate, Peak Flow) 4) Storage Rate = Peak Flow - Release Rate 5) Storage = Duration x Storage Rate 6) Maximum Storage = Max Storage Over Duration 7) Parameters a,b,c are for City of Ottawa															

Table D-14 Storage Volumes for 2-year, 5-Year and 100-Year Storms Area: PST-4

Area No: PST-4 $C_{AVG} = 0.58$ (2-yr) $C_{AVG} = 0.58$ (5-yr) $C_{AVG} = 0.73$ (100-yr, Max 1.0) Time Interval = 2.00 (mins) Drainage Area = 0.2005 (hectares)																
Actual Release Rate (L/sec) = 33.0 Percentage of Actual Rate (City of Ottawa requirement) = 50% Release Rate Used for Estimation of 100-year Storage (L/sec) = 16.5																
Duration (min)	Release Rate = 11.4 (L/sec) Return Period = 2 (years) IDF Parameters, A = 732.951, B = 0.810 $(I = A/(T_c+C))$, C = 6.199					Release Rate = 15.4 (L/sec) Return Period = 5 (years) IDF Parameters, A = 998.071, B = 0.814 $(I = A/(T_c+C))$, C = 6.053					Release Rate = 16.5 (L/sec) Return Period = 100 (years) IDF Parameters, A = 1735.688, B = 0.820 $(I = A/(T_c+C))$, C = 6.014					
	Rainfall Intensity, I (mm/hr)	Peak Flow (L/sec)	Release Rate (L/sec)	Storage Rate (L/sec)	Storage (m ³)	Rainfall Intensity, I (mm/hr)	Peak Flow (L/sec)	Release Rate (L/sec)	Storage Rate (L/sec)	Storage (m ³)	Rainfall Intensity, I (mm/hr)	Peak Flow (L/sec)	Release Rate (L/sec)	Storage Rate (L/sec)	Storage (m ³)	
0	167.2	54.1	11.36	42.7	0.00	230.5	74.5	15.405	59.1	0.00	398.6	161.1	16.5	144.6	0.00	
2	133.3	43.1	11.36	31.7	3.81	182.7	59.1	15.405	43.7	5.24	315.0	127.3	16.5	110.8	13.30	
4	111.7	36.1	11.36	24.8	5.94	152.5	49.3	15.405	33.9	8.14	262.4	106.0	16.5	89.5	21.49	
6	96.6	31.2	11.36	19.9	7.16	131.6	42.5	15.405	27.1	9.77	226.0	91.3	16.5	74.8	26.94	
8	85.5	27.6	11.36	16.3	7.81	116.1	37.5	15.405	22.1	10.62	199.2	80.5	16.5	64.0	30.72	
10	76.8	24.8	11.36	13.5	8.08	104.2	33.7	15.405	18.3	10.97	178.6	72.2	16.5	55.7	33.39	
12	69.9	22.6	11.36	11.2	8.09	94.7	30.6	15.405	15.2	10.95	162.1	65.5	16.5	49.0	35.29	
14	64.2	20.8	11.36	9.4	7.90	86.9	28.1	15.405	12.7	10.67	148.7	60.1	16.5	43.6	36.62	
16	59.5	19.2	11.36	7.9	7.57	80.5	26.0	15.405	10.6	10.18	137.5	55.6	16.5	39.1	37.52	
18	55.5	17.9	11.36	6.6	7.11	75.0	24.2	15.405	8.8	9.54	128.1	51.8	16.5	35.3	38.08	
20	52.0	16.8	11.36	5.5	6.56	70.3	22.7	15.405	7.3	8.77	120.0	48.5	16.5	32.0	38.37	
22	49.0	15.8	11.36	4.5	5.93	66.1	21.4	15.405	6.0	7.89	112.9	45.6	16.5	29.1	38.43	
24	46.4	15.0	11.36	3.6	5.24	62.5	20.2	15.405	4.8	6.93	106.7	43.1	16.5	26.6	38.32	
26	44.0	14.2	11.36	2.9	4.49	59.3	19.2	15.405	3.8	5.90	101.2	40.9	16.5	24.4	38.04	
28	41.9	13.6	11.36	2.2	3.70	56.5	18.3	15.405	2.9	4.80	96.3	38.9	16.5	22.4	37.64	
30	40.0	12.9	11.36	1.6	2.86	53.9	17.4	15.405	2.0	3.65	91.9	37.1	16.5	20.6	37.12	
32	38.3	12.4	11.36	1.0	1.99	51.6	16.7	15.405	1.3	2.46	87.9	35.5	16.5	19.0	36.51	
34	36.8	11.9	11.36	0.5	1.09	49.5	16.0	15.405	0.6	1.22	84.3	34.1	16.5	17.6	35.81	
36	35.4	11.4	11.36	0.1	0.17	47.6	15.4	15.405	0.0	-0.05	81.0	32.7	16.5	16.2	35.03	
38	34.1	11.0	11.36	-0.3	-0.78	45.8	14.8	15.405	-0.6	-1.36	77.9	31.5	16.5	15.0	34.19	
40	32.9	10.6	11.36	-0.7	-1.75	44.2	14.3	15.405	-1.1	-2.69	75.1	30.4	16.5	13.9	33.28	
Max =					8.09						10.97	38.43				
Notes																
1) Peak flow is equal to the product of $2.78 \times C \times I \times A$																
2) Rainfall Intensity, $I = A/(T_c+C)^B$																
3) Release Rate = Min (Release Rate, Peak Flow)																
4) Storage Rate = Peak Flow - Release Rate																
5) Storage = Duration x Storage Rate																
6) Maximum Storage = Max Storage Over Duration																
7) Parameters a,b,c are for City of Ottawa																

Table D15: 5-year & 100-year Roof Design Sheet - For Roof Drains on Tower A using Flow Controlled Roof Drains

Project: 365 Forest Street
 Location: City of Ottawa
 Date: Nov 2021

Area #	Drain Type	Roof Drain Type	No Drains per Area	No of Weirs per Drain	Weir Position	Runoff Coeff (Cavg)		Drainage Area		5-year Event					100-year Event					Storage Required (ARM)		Maximum Storage Provided at Spill Elevation					
						5-year	100-year	m ²	ha	Runoff Rate (L/sec)	5yr Ponding Depth (mm)	Roof Drain Capacity Per Weir (gpm)	Roof Drain Capacity Per Drain per weir (gpm)	Roof Drain Capacity Per Drain (L/sec)	Total Flow From Roof Drains (L/sec)	Runoff Rate (L/sec)	100yr Ponding Depth (mm)	Roof Drain Capacity Per Weir (gpm)	Roof Drain Capacity Per Drain per weir (gpm)	Roof Drain Capacity Per Drain (L/sec)	Total Flow From Roof Drains (L/sec)	5-year (m ³)	100-year (m ³)	Area Available for Storage (m ²)	Max Prism Depth (mm)	Max Prism Volume (m ³)	Total Volume (m ³)
R-A1	RD	RD1	1	1	3-1/4 open	0.90	0.90	252	0.0252	6.569	107	12.9	12.9	0.811	0.811	11.258	131	14.1	14.1	0.886	0.886	4.54	8.49	252	150	12.6	12.60
R-A2	RD	RD1	1	1	3-1/4 open	0.90	0.90	182	0.0182	4.745	103	12.6	12.6	0.797	0.797	8.131	129	14.0	14.0	0.880	0.880	2.96	5.77	182	150	9.1	9.10
R-A3	RD	RD1	1	1	3-1/4 open	0.90	0.90	229	0.0229	5.970	106	12.8	12.8	0.808	0.808	10.231	131	14.1	14.1	0.886	0.886	4.02	7.60	229	150	11.5	11.45
R-A4	RD	RD1	1	1	3-1/4 open	0.90	0.90	103	0.0103	2.685	94	12.2	12.2	0.770	0.770	4.602	121	13.6	13.6	0.855	0.855	1.26	2.73	103	150	5.2	5.15
R-A5	RD	RD1	1	1	3-1/4 open	0.90	0.90	147	0.0147	3.832	100	12.5	12.5	0.789	0.789	6.567	128	13.9	13.9	0.877	0.877	2.17	4.54	147	150	7.4	7.35
R-A6	RD	RD1	1	1	3-1/4 open	0.90	0.90	285	0.0285	7.430	110	13.0	13.0	0.820	0.820	12.733	138	14.4	14.4	0.908	0.908	5.61	11.10	285	150	14.3	14.25
R-A7	RD	RD2	1	1	1-None	0.90	0.90	87	0.0087	2.268		35.9	35.9	2.268	2.268	3.887		61.6	61.6	3.887	3.887						
Totals						0.9	0.9	1,285	0.1285	33,499		111.94		7.06	7.06	57.41		145.51		9.18	9.18	20.57	40.23	1198		59.9	59.9
Min																		94									
Max																		138									

Runoff Based on the Following:

Storm Frequency (years) = 5 100
 Time of Conc (mins) = 10 10
 Storm Intensity (mm/hr) = 104.2 178.6

Q_{yr}(cont) = 5.3
 V_{2yr} = 15.4

Roof Drains have Following Flow Rates: WATTS Flow Controlled Drain

Weir Position	Flow (gpm) per depth							Max Flow Rate per Weir
	0	25	50	75	100	125	150	
0	0	0.025	0.05	0.075	0.1	0.125	0.15	
1-None	0	0	0	0	0	0	0	0.000
2-Closed	0	5	5	5	5	5	5	0.315
3-1/4 open	0	5	10	11	13	14	15	0.946
4-1/2 open	0	5	10	12	15	18	20	1.262
5-3/4 open	0	5	10	14	18	21	25	1.577
6-Full	0	5	10	15	20	25	30	1.893

Roof Drain Types

Drain Type = RD1 RD2
 Max Overflow Depth (mm) 150 mm 150 mm
 Flow Controlled (Yes/No) Yes No
 Ponding Yes No
 Weir Desc Accutrol n/a
 No. Weirs 1 n/a

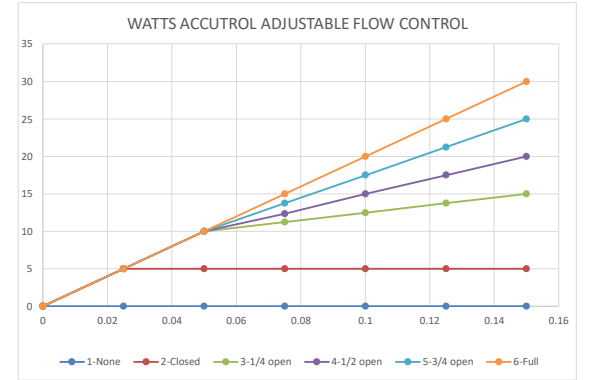

Table D16: 5-year & 100-year Roof Design Sheet - For Roof Drains on Tower B using Flow Controlled Roof Drains

Project: 365 Forest Street
 Location: City of Ottawa
 Date: Nov 2021

Area #	Drain Type	Roof Drain Type	No Drains per Area	No of Weirs per Drain	Weir Position	Runoff Coeff (Cavg)		Drainage Area		5-year Event					100-year Event					Storage Required (ARM)		Maximum Storage Provided at Spill Elevation					
						5-year	100-year	m ²	ha	Runoff Rate (L/sec)	5yr Ponding Depth (mm)	Roof Drain Capacity Per Weir (gpm)	Roof Drain Capacity Per Drain per weir (gpm)	Roof Drain Capacity Per Drain (L/sec)	Total Flow From Roof Drains (L/sec)	Runoff Rate (L/sec)	100yr Ponding Depth (mm)	Roof Drain Capacity Per Weir (gpm)	Roof Drain Capacity Per Drain per weir (gpm)	Roof Drain Capacity Per Drain (L/sec)	Total Flow From Roof Drains (L/sec)	5-year (m ³)	100-year (m ³)	Area Available for Storage (m ²)	Max Prism Depth (mm)	Max Prism Volume (m ³)	Total Volume (m ³)
R-B1	RD	RD1	1	1	3-1/4 open	0.90	0.90	181	0.0181	4.719	103	12.7	12.7	0.798	0.798	8.086	131	14.1	14.1	0.886	0.886	2.96	6.05	181	150	9.1	9.05
R-B2	RD	RD1	1	1	3-1/4 open	0.90	0.90	215	0.0215	5.605	106	12.8	12.8	0.808	0.808	9.605	134	14.2	14.2	0.896	0.896	3.78	7.63	215	150	10.8	10.75
R-B3	RD	RD1	1	1	3-1/4 open	0.90	0.90	290	0.0290	7.560	110	13.0	13.0	0.820	0.820	12.956	138	14.4	14.4	0.908	0.908	5.75	11.36	290	150	14.5	14.50
R-B4	RD	RD1	1	1	3-1/4 open	0.90	0.90	316	0.0316	8.238	111	13.1	13.1	0.823	0.823	14.117	139	14.5	14.5	0.912	0.912	6.46	12.71	316	150	15.8	15.80
R-B5	RD	RD1	1	1	3-1/4 open	0.90	0.90	186	0.0186	4.849	104	12.7	12.7	0.801	0.801	8.310	132	14.1	14.1	0.890	0.890	3.07	6.27	186	150	9.3	9.30
R-B6	RD	RD1	1	1	3-1/4 open	0.90	0.90	196	0.0196	5.110	105	12.8	12.8	0.804	0.804	8.756	132	14.1	14.1	0.890	0.890	3.31	6.74	196	150	9.8	9.80
R-B7	RD	RD2	1	1	1-None	0.90	0.90	70	0.0070	1.825		28.9	28.9	1.825	1.825	3.127		49.6	49.6	3.127	3.127						
Totals						0.9	0.9	1,454	0.1454	37.904		103	105.87	6.68	6.68	64.96		134.87	8.51	8.51	25.34	50.76	1384		69.2	69.2	
Min												103															
Max												111															

Runoff Based on the Following:

Storm Frequency (years) = 5 100
 Time of Conc (mins) = 10 10
 Storm Intensity (mm/hr) = 104.2 178.6

Qyr(cont) = 5.0
 V2yr = 19.0

Roof Drain Types

Drain Type = RD1 RD2
 Max Overflow Depth (mm) 150 mm 150 mm
 Flow Controlled (Yes/No) Yes No
 Ponding Yes No
 Weir Desc Accutrol n/a
 No. Weirs 1 n/a

Roof Drains have Following Flow Rates: WATTS Flow Controlled Drain

Weir Position	Flow (gpm) per depth							Max Flow Rate per Weir
	0	25	50	75	100	125	150	
1-None	0	0	0	0	0	0	0	0.000
2-Closed	0	5	5	5	5	5	5	0.315
3-1/4 open	0	5	10	11	13	14	15	0.946
4-1/2 open	0	5	10	12	15	18	20	1.262
5-3/4 open	0	5	10	14	18	21	25	1.577
6-Full	0	5	10	15	20	25	30	1.893

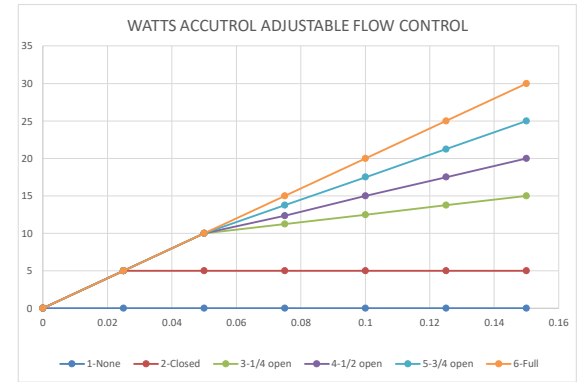

Appendix E – Consultation / Correspondence

Pre-consultation meeting minutes

Email on Water System Boundary Conditions

Email Sent to RCVA on Stormwater Management Requirements

Email Received from RCVA on Stormwater Management Requirements

Email Correspondence with City of Ottawa re SWM requirements for Pinecrest Creek/Westboro

365 Forest Street, 1420 Richmond Road & 2583-2589 Bond Street
Pre-Consultation Meeting Minutes

Location: Room 4103E, City Hall
Date: May 28, 2pm to 3pm

Attendee	Role	Organization
Mary Dickinson	Planner	City of Ottawa
Santosh Kuruvilla	Project Manager (Infrastructure)	
Melanie Knight	Planner (Urban Design)	
Samantha Gatchene	Planning Assistant	
Jamie Posen	Planner	FoTenn
Steve Heafey	Owner's Representative	Heafey Group
Carmine Zayoun	Owner's Representative	
Shawn Vandette	Owner	
Mathieu LaPalm	Architect	LaPalm Rheault Architects

Comments from Applicant

1. The applicant is proposing the development two 12-storey high rise buildings at 365 Forest Street, 1420 Richmond Road, and 2583-2589 Bond Street. The buildings would be residential in nature with 333 units total. Currently, no commercial uses at grade are proposed.
2. Underground parking and surface vehicle parking would be provided as well as bicycle parking.
3. The current two access points off Richmond Road and Forest Street are proposed to be maintained.

Planning Comments

1. A Zoning By-law Amendment and an Official Plan Amendment would be required to permit the 12-storey building option, in accordance with the settlement of Official Plan Amendment 150 (OPA 150). The amendment to Section 3.6.3 maintains that up to 9-storeys is permitted on Arterial Mainstreets unless stated in a secondary plan or if the building is located at a qualifying node defined as a location that is:
 - a. within 400 metres walking distance of a Rapid Transit Station on Schedule D of this Plan; or
 - b. directly abutting an intersection of the Mainstreet with another Mainstreet or a Transit Priority Corridor on Schedule D of this Plan; or

- c. directly abutting a Major Urban Facility.
2. Under OPA 150, the site is not considered a node and would require an OPA. Information regarding the settlement of OPA 150 building height and design appeals can be found in the April 24th [Planning Committee Report](#).
3. The City is in the early stages of creating a secondary plan for the area. This process is scheduled to begin in late 2019/early 2020. City staff strongly encourage the applicant to participate in that process.
4. Cash-in-lieu of parkland and associated appraisal fee will be required as a condition of approval as per the [Parkland Dedication By-law](#). For commercial and industrial purposes, parkland is calculated as 2% of the gross land area of the site being developed.
5. Building A should include a main front entrance directly from Richmond Road, or at the corner where Richmond Road and Forest Street meet. This is in accordance with the current AM10 zoning requirements. Please refer to the development standards in this zone for all other provisions including minimum glazing, minimum ceiling heights for the first storey etc.

Urban Design Comments

1. Site design:
 - All vehicular access should be off of Forest and/or Bond. Preference would be for all vehicular access off of Bond. Bond Street should be treated as a 'laneway' to the site where access to underground parking and any loading or servicing can be located.
 - There are hydro lines along Forest and Bond, which requires minimum building setbacks. If the hydro lines are to be buried, the building should still be set back to allow for enough space for street trees along Forest and Bond.
 - A sidewalk should be provided along Forest to connect to the sidewalk recently built along Forest towards Carling (Dymon Storage site).
 - All parking should be located underground. This would significantly improve the immediate area, which is dominated by surface parking lots.
 - There is an opportunity at the corner of Richmond and Forest to create a plaza space either as a POPS (privately owned public spaces) or a patio space associated with a commercial use
2. Built form/building design:

- The building separation in the current design between Building A and B should be maintained to break up the façade along Forest.
- The long frontage along Forest needs to be designed well to ensure that there is permeability to the site and the buildings do not negatively dominate the streetscape.

3. Building A (12 storeys)

- With vehicular access from Richmond removed, the building fronting onto Richmond Road can be designed as a complete perimeter corner building with design emphasis on the corner of Richmond and Forest.
- Main pedestrian entrances should be located off of Richmond with a corner entrance/plaza space at the corner of Richmond and Forest.
- The building should be designed with consideration for the City's [High Rise Design Guidelines](#) specifically with respect to built form (chapter 2).
- Consider the shadowing impacts to the low-rise residential homes on the north side of Richmond Road with the shaping of Building A

4. Building B (12 storeys)

- At 12 storeys, the mass of Building B dominates the site and Bond Street. A reduced building footprint and a reduced height down to 9 storeys is recommended. Please refer to Chapter 2 in the [High Rise Design Guidelines](#) for guidance on the appropriateness, mass and height of a bar building.
- This building should create a transition from the newly constructed building at 2599 Carling Avenue.
- The roof top amenity space could be realigned north/south to take better advantage of sun exposure and provide relief between the Building A and B.
- The building should be designed with consideration for the City's [High Rise Design Guidelines](#) specifically with respect to built form (Chapter 2).

5. General comments:

- This site presents an opportunity for redevelopment which can improve the existing context that is dominated by surface parking lots and oversized (high rise) bar buildings.
- With frontage on three streets, there is an opportunity to make a significant contribution to the public realm. Please refer to the City's [High Rise Design](#)

[Guidelines](#) (chapter 3) for more direction on the design of the pedestrian realm.

Engineering Comments

1. Stormwater quantity control criteria – control the quantity to the 5-year pre-development/existing level for all storms up to and including the 100-year storm.
2. When calculating the existing composite runoff coefficient (C) for the site, please provide a drawing showing the individual area and its runoff coefficient.
3. It appears that the subject site consists of more than one parcel. Therefore, MECP ECA is required. All parcels can be merged into one to avoid MECP ECA requirement.
4. Stormwater quality control – Consult with the Conservation Authority (RVCA) for their requirements. Include the correspondence with RVCA in the stormwater/site servicing report.
5. Show the existing storm and sanitary lateral service connections on the site servicing plan.
6. When using the modified rational method to calculate the storage requirements for the site, the underground storage should not be included in the overall available storage. The modified rational method assumes that the restricted flow rate is constant throughout the storm which, in this case, underestimates the storage requirement prior to the 1: 100-year head elevation being reached. Alternately, if you wish to include the underground storage, you may use an assumed average release rate equal to 50% of the peak allowable rate. Otherwise, disregard the underground storage as available storage or provide modeling to support the design.
7. Engineering plans are to be submitted on standard A1 size (594mm x 841mm) sheets.
8. Provide the following information for water main boundary conditions:
 - a. Location map with water service connection location
 - b. Average daily demand (l/s)
 - c. Maximum daily demand (l/s)
 - d. Maximum hourly demand
 - e. Fire flow demand (provide fire detailed flow calculations based on the fire underwriters survey method)
 - f. If you are proposing any exterior light fixtures, all must be included and approved as part of the site plan approval. Therefore, the lights must be clearly identified by make, model and part number. All external light

fixtures must meet the criteria for full cut-off classification as recognized by the Illuminating Engineering Society of North America (IESNA or IES), and must result in minimal light spillage onto adjacent properties (as a guideline, 0.5 fc is normally the maximum allowable spillage). In order to satisfy these criteria, the applicant must provide certification from an acceptable professional engineer. The location of all exterior fixtures, a table showing the fixture types (including make, model, part number), and the mounting heights must be included on a plan.

Transportation Comments

1. Please revise your screening form to indicate that the property is located on a Spine Bicycle Network (Richmond)
2. Follow Traffic Impact Assessment Guidelines
 - a. Traffic Impact Assessment will be required.
 - b. Start this process asap.
 - c. Applicant advised that their application will not be deemed complete until the submission of the draft step 1-4, including the functional draft RMA package (if applicable) and/or monitoring report (if applicable).
3. ROW protection on Richmond between HWY 417 and Ottawa River Parkway is 37.5m even (18.75 metres from centreline of road).
4. Corner triangles as per OP Annex 1 - Road Classification and Rights-of-Way at the following location on the final plan will be required:
 - a. Local Road to Local Road: 3 metre x 3 metres
 - b. Local Road to Arterial Road: 5 metre x 5 metres
5. Noise Impact Studies required for the following:
 - a. Road
 - b. Stationary (due to the proximity to neighbouring exposed mechanical equipment) and/or (if there will be any exposed mechanical equipment due to the proximity to neighbouring noise sensitive land uses)
6. Clear throat requirements on an arterial (Richmond) are as follows:

Apartments	Unit Count	Length (m)
	<100 units	15
	100-200 units	25
	>200 units	40

**Please note that vehicular access from Richmond Road is not our desired configuration.

7. On site plan:
 - a. Show all details of the roads abutting the site up to and including the opposite curb; include such items as pavement markings, accesses and/or sidewalks.
 - b. Turning templates will be required for all accesses showing the largest vehicle to access the site; required for internal movements and at all access (entering and exiting and going in both directions).
 - c. Show all curb radii measurements; ensure that all curb radii are reduced as much as possible
 - d. Show lane/aisle widths.
 - e. Sidewalk and cycle tracks are to be continuous across access as per City Specification 7.1.
 - f. Grey out any area that will not be impacted by this application.

Requested Plans and Studies

1. A list of required plans and studies required for a complete combined Official Plan Amendment, Zoning By-law Amendment and Site Plan Control application have been attached.

Process

1. This is a pre-consultation to determine the nature of the application and the requirements for a complete application.
 - a. For an Official Plan Amendment application, subject to Public Consultation, the application form, timeline, and fees can be found [here](#).
 - b. For a Major Zoning By-law Amendment application, Manager Approval, subject to Public Consultation, the application form, timeline, and fees can be found [here](#).
2. This proposal will trigger a Site Plan Control application, Manager Approval, subject to Public Consultation. The proposal would fall under the 'complex' category as per the [Site Plan Control Subtype Thresholds](#). The application form, timeline and fees can be found [here](#).
3. The applicant will be required to present their proposal to the Urban Design Review Panel (UDRP). The site is in a Design Priority Area and a pre-consultation is recommended. The next UDRP meeting is scheduled for Friday, July 12th and the submission deadline is Friday, June 28. Information regarding the review process and timelines can be found [here](#).

Please refer to the links to "[Guide to preparing studies and plans](#)" and [fees](#) for general information. Additional information is available related to [building permits, development charges, and the Accessibility Design Standards](#). Be aware that other fees and permits may be required, outside of the development review process. You may obtain background drawings by contacting informationcentre@ottawa.ca.

These pre-con comments are valid for one year. If you submit a development application(s) after this time, you may be required to meet for another pre-consultation meeting and/or the submission requirements may change. You are as well encouraged to contact us for a follow-up meeting if the plan/concept will be further refined.

Please contact me at mary.dickinson@ottawa.ca or at 613-580-2424 extension 13923 if you have any questions.

Sincerely,

A handwritten signature in black ink, appearing to read 'MD', with a long horizontal flourish extending to the right.

Mary Dickinson MCIP RPP
Planner II
Development Review - West

Jennifer Diaz

From: Kuruvilla, Santhosh <Santhosh.Kuruvilla@ottawa.ca>
Sent: Wednesday, June 2, 2021 1:56 PM
To: Bruce Thomas; Jennifer Diaz
Cc: Jason Fitzpatrick
Subject: RE: Request for Boundary Conditions - 365 Forest Street
Attachments: 365 Forest May 2021 - 2nd Submission.pdf



CAUTION: This email originated from outside of the organization. Do not click links or open attachments unless you recognize the sender and know the content is safe.

Hi Bruce,

The following are boundary conditions, HGL, for hydraulic analysis at 365 Forest (zone 1W) assumed to be connected to the 305 mm on Forest Street (see attached PDF for location).

Minimum HGL = 108.3 m

Maximum HGL = 115.4 m

MaxDay + FireFlow (133L/s) = 109.8 m

MaxDay + FireFlow (183L/s) = 109.2 m

These are for current conditions and are based on computer model simulation.

Disclaimer: The boundary condition information is based on current operation of the city water distribution system. The computer model simulation is based on the best information available at the time. The operation of the water distribution system can change on a regular basis, resulting in a variation in boundary conditions. The physical properties of watermains deteriorate over time, as such must be assumed in the absence of actual field test data. The variation in physical watermain properties can therefore alter the results of the computer model simulation.

Thanks,

Santhosh

From: Kuruvilla, Santhosh
Sent: May 31, 2021 11:33 AM
To: Bruce Thomas <bruce.thomas@exp.com>; Jennifer Diaz <jennifer.diaz@exp.com>
Cc: Jason Fitzpatrick <jason.fitzpatrick@exp.com>
Subject: RE: Request for Boundary Conditions - 365 Forest Street

Ok, thanks Bruce.

Santhosh

From: Bruce Thomas <bruce.thomas@exp.com>
Sent: May 31, 2021 11:16 AM
To: Kuruvilla, Santhosh <Santhosh.Kuruvilla@ottawa.ca>; Jennifer Diaz <jennifer.diaz@exp.com>
Cc: Jason Fitzpatrick <jason.fitzpatrick@exp.com>
Subject: RE: Request for Boundary Conditions - 365 Forest Street

CAUTION: This email originated from an External Sender. Please do not click links or open attachments unless you recognize the source.

ATTENTION : Ce courriel provient d'un expéditeur externe. Ne cliquez sur aucun lien et n'ouvrez pas de pièce jointe, excepté si vous connaissez l'expéditeur.

Hi Santhosh,

A double feed is proposed from the location on Forest with a valve in between the two proposed connections.

Bruce Thomas, P.Eng.

EXP | Senior Project Manager

t : +1.613.688.1899 | m : +1.613.852.8753 | e : bruce.thomas@exp.com

[exp.com](#) | [legal disclaimer](#)
keep it green, read from the screen

From: Kuruvilla, Santhosh <Santhosh.Kuruvilla@ottawa.ca>
Sent: Monday, May 31, 2021 10:55 AM
To: Jennifer Diaz <jennifer.diaz@exp.com>
Cc: Jason Fitzpatrick <jason.fitzpatrick@exp.com>; Bruce Thomas <bruce.thomas@exp.com>
Subject: RE: Request for Boundary Conditions - 365 Forest Street



CAUTION: This email originated from outside of the organization. Do not click links or open attachments unless you recognize the sender and know the content is safe.

Hi Jennifer,

We noticed that the previous boundary conditions that you requested for this site required two connections. Now there is only being requested but the demands require 2 connections (see section 4.3 of the Ottawa Water Distribution Design Guideline).

Please update your map showing both connection points and send us a copy.

Thanks,

Santhosh

From: Jennifer Diaz <jennifer.diaz@exp.com>
Sent: May 26, 2021 4:54 PM
To: Kuruvilla, Santhosh <Santhosh.Kuruvilla@ottawa.ca>
Cc: Jason Fitzpatrick <jason.fitzpatrick@exp.com>; Bruce Thomas <Bruce.Thomas@exp.com>
Subject: RE: Request for Boundary Conditions - 365 Forest Street

CAUTION: This email originated from an External Sender. Please do not click links or open attachments unless you recognize the source.

ATTENTION : Ce courriel provient d'un expéditeur externe. Ne cliquez sur aucun lien et n'ouvrez pas de pièce jointe, excepté si vous connaissez l'expéditeur.

Hi Santhosh,

Please see the attached requested information and summary of the water demand below:

Average Day: 2.5 L/sec

Max Day: 6.2 L/sec

Peak Hour: 13.6 L/sec

Fire flow (RFF): Tower A: 133 L/sec, Tower B: 183 L/sec (based on FUS method)

Max Day + FF: 189.2 L/sec.

Please advise if you require anything else.

Thank you

Jennifer Diaz, P.Eng.

EXP | Branch Manager

t : +1.613.542.1253, 122 | m : +1.613.484.2286 | e : jennifer.diaz@exp.com

exp.com | [legal disclaimer](#)

keep it green, read from the screen

From: Kuruvilla, Santhosh <Santhosh.Kuruvilla@ottawa.ca>

Sent: Friday, May 21, 2021 3:23 PM

To: Jennifer Diaz <jennifer.diaz@exp.com>

Subject: RE: Request for Boundary Conditions - 365 Forest Street



CAUTION: This email originated from outside of the organization. Do not click links or open attachments unless you recognize the sender and know the content is safe.

Hi Jennifer,

Please provide the following information for water boundary condition request.

- Provide the following information for water main boundary conditions:
 1. Location map with water service connection location(s).
 2. Average daily demand (l/s).
 3. Maximum daily demand (l/s).
 4. Maximum hourly demand (l/s).
 5. Fire flow demand (provide detailed fire flow calculations based on Fire Underwriters survey (FUS) Water Supply for Public Fire Protection). Exposure separation distances shall be defined on a figure to support the FUS calculation and required fire flow (RFF).

6. Hydrant capacity shall be assessed to demonstrate the RFF can be achieved. Please identify which hydrants are being considered to meet the RFF on a fire hydrant coverage plan as part of the boundary conditions request.

Please ensure all information listed above must be provided in the same email.

Thanks,

Santhosh

From: Jennifer Diaz <jennifer.diaz@exp.com>
Sent: May 20, 2021 8:50 PM
To: Kuruvilla, Santhosh <Santhosh.Kuruvilla@ottawa.ca>
Subject: RE: Request for Boundary Conditions - 365 Forest Street

CAUTION: This email originated from an External Sender. Please do not click links or open attachments unless you recognize the source.

ATTENTION : Ce courriel provient d'un expéditeur externe. Ne cliquez sur aucun lien et n'ouvrez pas de pièce jointe, excepté si vous connaissez l'expéditeur.

Good evening,

Further to our request there have been minor changes to the design of the proposed development at the subject address. We have since completed additional calculations and estimate the following demands and flow requirements:

Average Day: 2.5 L/sec
Max Day: 6.2 L/sec
Peak Hour: 13.6 L/sec
Fire flow (RFF): Tower A: 133 L/sec, Tower B: 183 L/sec (based on FUS method)
Max Day + FF: 189.2 L/sec.

Please provide the updated hydraulic boundary conditions based on our estimated values.

Thank you!

Jennifer Diaz, P.Eng.

EXP | Branch Manager

t : +1.613.542.1253, 122 | m : +1.613.484.2286 | e : jennifer.diaz@exp.com

*[exp.com](#) | [legal disclaimer](#)
keep it green, read from the screen*

From: Kuruvilla, Santhosh <Santhosh.Kuruvilla@ottawa.ca>
Sent: Wednesday, July 24, 2019 9:42 AM
To: Dickinson, Mary <mary.dickinson@ottawa.ca>; Jason Fitzpatrick <jason.fitzpatrick@exp.com>
Subject: RE: Request for Boundary Conditions - 365 Forest Street

Hi Jason,

Here is the boundary conditions for the subject application. Please see attached for the connection locations.

The following are boundary conditions, HGL, for hydraulic analysis at 365 Forest (zone 1W) assumed to be connected to the 305mm on Forest and 305mm on Richmond (see attached PDF for location).

Minimum HGL = 108.5m, same at both connections

Maximum HGL = 115.7m, same at both connections

MaxDay + FireFlow (150L/s) = 107.0m, Forest connection

MaxDay + FireFlow (150L/s) = 109.0m, Richmond connection

These are for current conditions and are based on computer model simulation.

Disclaimer: The boundary condition information is based on current operation of the city water distribution system. The computer model simulation is based on the best information available at the time. The operation of the water distribution system can change on a regular basis, resulting in a variation in boundary conditions. The physical properties of watermains deteriorate over time, as such must be assumed in the absence of actual field test data. The variation in physical watermain properties can therefore alter the results of the computer model simulation.

Santhosh

From: Dickinson, Mary

Sent: July 10, 2019 3:58 PM

To: Kuruvilla, Santhosh <Santhosh.Kuruvilla@ottawa.ca>; jason.fitzpatrick@exp.com

Subject: FW: Request for Boundary Conditions - 365 Forest Street

Hi Jason,

I'm forwarding your request to Santhosh Kuruvilla who will be able to make the request for the boundary conditions.

Thank you,
Mary

Mary Dickinson, MCIP, RPP

Planner

Development Review West

Urbaniste

Examen des demandes d'aménagement ouest

City of Ottawa | Ville d'Ottawa

☎ 613.580.2424 ext./poste 13923

ottawa.ca/planning/ / ottawa.ca/urbanisme

From: Jason Fitzpatrick <jason.fitzpatrick@exp.com>

Sent: July 10, 2019 3:32 PM

To: Dickinson, Mary <mary.dickinson@ottawa.ca>

Cc: Bruce Thomas <bruce.thomas@exp.com>; Moe Ghadban <Moe.Ghadban@exp.com>

Subject: Request for Boundary Conditions - 365 Forest Street

CAUTION: This email originated from an External Sender. Please do not click links or open attachments unless you recognize the source.

ATTENTION : Ce courriel provient d'un expéditeur externe. Ne cliquez sur aucun lien et n'ouvrez pas de pièce jointe, excepté si vous connaissez l'expéditeur.

Hi Mary,

We are working with the Heafey Group on a site plan application for 365 Forest Street, and would appreciate if you could arrange for IAD/water Resources to provide hydraulic boundary conditions that we will need for the watermain design. I have attached a sketch of the site and the approximate boundary condition locations. We are requesting boundary conditions at locations at this time to evaluate the best connection location within the right of way.

The following is a summary of the demands and the required fire flows (RFF) we have estimated. We would appreciate the hydraulic boundary conditions based on our estimated water demands and required fire flows as noted below:

Average Day: 2.4 L/sec

Max Day: 6.0 L/sec

Peak Hour: 13.2 L/sec

Fire flow (RFF): Tower A: 100 L/sec, Tower B: 150 L/sec (worst case). (based on FUS method)

Max Day + FF: 156.0 L/sec.

In the event you require confirmation of the above demands and the RFF, I've attached the design tables for reference.

Regards,



Jason Fitzpatrick, P.Eng.

EXP | Project Engineer

t : +1.613.688.1899 | m : +1.613.302.7441 | e : jason.fitzpatrick@exp.com

2650 Queensview Drive

Suite 100

Ottawa, ON K2B 8H6

CANADA

exp.com | [legal disclaimer](#)

keep it green, read from the screen

'
'
This e-mail originates from the City of Ottawa e-mail system. Any distribution, use or copying of this e-mail or the information it contains by other than the intended recipient(s) is unauthorized. Thank you.

Le présent courriel a été expédié par le système de courriels de la Ville d'Ottawa. Toute distribution, utilisation ou reproduction du courriel ou des renseignements qui s'y trouvent par une personne autre que son destinataire prévu est interdite. Je vous remercie de votre collaboration.

'
'
This e-mail originates from the City of Ottawa e-mail system. Any distribution, use or copying of this e-mail or the information it contains by other than the intended recipient(s) is unauthorized. Thank you.

Le présent courriel a été expédié par le système de courriels de la Ville d'Ottawa. Toute distribution, utilisation ou reproduction du courriel ou des renseignements qui s'y trouvent par une personne autre que son destinataire prévu est interdite. Je vous remercie de votre collaboration.

'
'
This e-mail originates from the City of Ottawa e-mail system. Any distribution, use or copying of this e-mail or the information it contains by other than the intended recipient(s) is unauthorized. Thank you.

Le présent courriel a été expédié par le système de courriels de la Ville d'Ottawa. Toute distribution, utilisation ou reproduction du courriel ou des renseignements qui s'y trouvent par une personne autre que son destinataire prévu est interdite. Je vous remercie de votre collaboration.

'
'
This e-mail originates from the City of Ottawa e-mail system. Any distribution, use or copying of this e-mail or the information it contains by other than the intended recipient(s) is unauthorized. Thank you.

Le présent courriel a été expédié par le système de courriels de la Ville d'Ottawa. Toute distribution, utilisation ou reproduction du courriel ou des renseignements qui s'y trouvent par une personne autre que son destinataire prévu est interdite. Je vous remercie de votre collaboration.

Boundary Conditions for 365 Forest Street

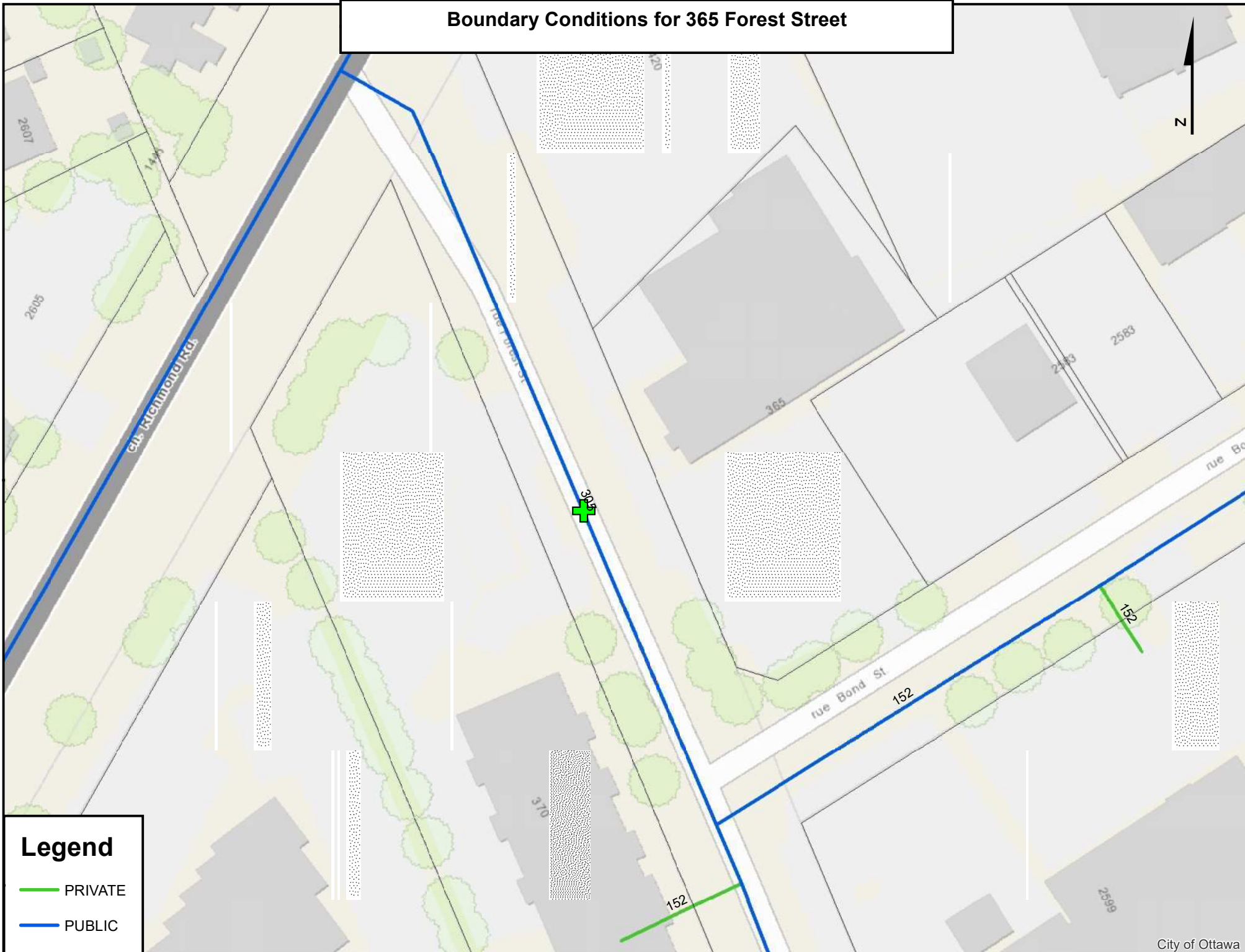

Legend

- PRIVATE
- PUBLIC

Jennifer Diaz

From: Miliu, Ghislaine <ghislaine.miliu@ottawa.ca>
Sent: Wednesday, October 13, 2021 11:17 AM
To: Bruce Thomas
Cc: Jennifer Diaz
Subject: RE: 365 Forest -Stormwater Management Criteria



CAUTION: This email originated from outside of the organization. Do not click links or open attachments unless you recognize the sender and know the content is safe.

Hi Bruce,

Please find some responses embedded in two of your emails below.

Please let me know if you have any other questions.

Kind regards,

Ghislaine

Ghislaine Miliu, P.Eng

Project Manager – Infrastructure Planning
Asset Management Branch
City of Ottawa | Ville d'Ottawa

From: Bruce Thomas <bruce.thomas@exp.com>
Sent: October 12, 2021 12:06 PM
To: Miliu, Ghislaine <ghislaine.miliu@ottawa.ca>
Cc: Jennifer Diaz <jennifer.diaz@exp.com>
Subject: RE: 365 Forest -Stormwater Management Criteria

CAUTION: This email originated from an External Sender. Please do not click links or open attachments unless you recognize the source.

ATTENTION : Ce courriel provient d'un expéditeur externe. Ne cliquez sur aucun lien et n'ouvrez pas de pièce jointe, excepté si vous connaissez l'expéditeur.

Hi Ghislaine,

Hope you had a great Thanksgiving weekend. Thanks for your response below.

Yes, we wish to exclude the uncontrolled drainage areas from the 10mm retention requirement, as it is would be very difficult collect the runoff.

For the larger events we would be ok with over controlling the release rate from other areas of the site, to account for the uncontrolled areas.

RESPONSE: Yes, for this project (given the outlet of the STM sewers system to Ottawa River), the small area of uncontrolled drainage may be excluded from meeting the 10 mm retention.

Please let us know when you discuss with your colleagues.

Thanks,

Bruce

Bruce Thomas, P.Eng.

EXP | Senior Project Manager

t : +1.613.688.1899 | m : +1.613.852.8753 | e : bruce.thomas@exp.com

[exp.com](#) | [legal disclaimer](#)

keep it green, read from the screen

From: Miliu, Ghislaine <ghislaine.miliu@ottawa.ca>

Sent: Thursday, October 7, 2021 3:39 PM

To: Bruce Thomas <bruce.thomas@exp.com>

Cc: Jennifer Diaz <jennifer.diaz@exp.com>

Subject: RE: 365 Forest -Stormwater Management Criteria



CAUTION: This email originated from outside of the organization. Do not click links or open attachments unless you recognize the sender and know the content is safe.

Hi Bruce (and Jennifer),

Re the uncontrolled drainage areas: is your question whether these areas be excluded from the 10 mm retention requirement **OR** are you asking if they can be excluded from the 10 mm retention requirement **AND** if runoff from these areas not contribute towards allowable release rate?

Once I hear back from you then I will reach out to my colleagues.

Thanks.
Ghislaine

From: Bruce Thomas <bruce.thomas@exp.com>

Sent: October 07, 2021 3:18 PM

To: Miliu, Ghislaine <ghislaine.miliu@ottawa.ca>

Cc: Jennifer Diaz <jennifer.diaz@exp.com>; Carmine Zayoun <carmine@zayoungroup.com>;

rakrawi@groupeheafey.com; Christian Rheault <C.Rheault@lrarch.ca>; Angel Rangel

<arangel@quadrantengineering.ca>; B. L. A. Mike Lennox (ml@jbla.ca) <ml@jbla.ca>

Subject: 365 Forest -Stormwater Management Criteria

CAUTION: This email originated from an External Sender. Please do not click links or open attachments unless you recognize the source.

ATTENTION : Ce courriel provient d'un expéditeur externe. Ne cliquez sur aucun lien et n'ouvrez pas de pièce jointe, excepté si vous connaissez l'expéditeur.

Hi Ghislaine,

Thank you for meeting with us to provide guidance on the requirements provided within the “Stormwater Management Guidelines for the Pinecrest/Westboro Area Final Report” as they relate to the planned development at 365 Forest Street.

As per our discussion, we request further clarification on the following:

1. The referenced SWM guidelines states that the 10 mm design storm is to be retained. Please confirm whether it would be acceptable to provide measures for excess retention in one area to account for areas with uncontrolled flow. i.e. capture +/- first 20mm on the roof. Is it possible to have a very restrictive release rate for the site/portion of the site that would drain the 10mm storm over a longer time frame of say a few days?

RESPONSE: Yes, for this project (given the outlet of the STM sewers system to Ottawa River) we will accept the provision for excess retention in one area to account for areas with uncontrolled flow. Similar to the Feedmill Creek retention criteria, please account for initial abstraction contributing towards the retention target.

2. Our current design for quantity control allows for overcontrol of the runoff from the roof area to account for small uncontrolled areas adjacent to the City right of way (Forest St and Bond St). Due to limitations on grading, location, size and existing conditions, would the City be agreeable to these areas remaining uncontrolled? i.e. not retaining the 10 mm storm at these locations?

RESPONSE: Please see October 12, 2021 clarification and City response.

3. Could you provide City contacts in the Buildings Department for our team to discuss the City’s preferred/acceptable methods for reuse of the captured stormwater (watering, maintenance/cleaning, reuse as greywater, etc.).

RESPONSE: For this project (given the outlet of the STM sewers system to Ottawa River), please identify as many opportunities to retain the first 10 mm onsite (where it makes sense). Unfortunately, the City does not have guidelines specific to water re-use systems (especially within the building). If infiltrating does not make sense (i.e subsurface infiltration LID on top of the parking garage), then please consider simple surface type LID that provide opportunities for evapotranspiration (designed to not cause nuisances like mosquito breeding grounds) or re-use systems that make sense for the site (i.e. water re-use for landscape irrigation). If 10 mm cannot be achieved on the entire site (excluding the small uncontrolled areas) then justify why not.

4. During pre-consultation with the City and Conservation Authority for this project, it was noted that quality control for the site was not required. The above noted guidelines require 80% TSS removal. There is limited area on site for vehicle use (lane and turning circle). Please verify quality control requirements.

RESPONSE: Please provide enhanced quality control (to treat runoff from surfaces with vehicular traffic). The sizing of the unit may be based on the area draining to the unit. If Rooftop runoff is not directed to the OGS then the Rooftop area can be excluded from the sizing of the OGS unit. If landscape runoff is not directed to the OGS unit then the OGS unit does not need to be sized including landscape area.

Thank you, we look forward to your reply.

Regards,



Bruce Thomas, P.Eng.

EXP | Senior Project Manager

t : +1.613.688.1899 | m : +1.613.852.8753 | e : bruce.thomas@exp.com

2650 Queensview Drive

Suite 100

Ottawa, ON K2B 8H6

CANADA

exp.com | [legal disclaimer](#)

keep it green, read from the screen

'
'
This e-mail originates from the City of Ottawa e-mail system. Any distribution, use or copying of this e-mail or the information it contains by other than the intended recipient(s) is unauthorized. Thank you.

Le présent courriel a été expédié par le système de courriels de la Ville d'Ottawa. Toute distribution, utilisation ou reproduction du courriel ou des renseignements qui s'y trouvent par une personne autre que son destinataire prévu est interdite. Je vous remercie de votre collaboration.

'
'
This e-mail originates from the City of Ottawa e-mail system. Any distribution, use or copying of this e-mail or the information it contains by other than the intended recipient(s) is unauthorized. Thank you.

Le présent courriel a été expédié par le système de courriels de la Ville d'Ottawa. Toute distribution, utilisation ou reproduction du courriel ou des renseignements qui s'y trouvent par une personne autre que son destinataire prévu est interdite. Je vous remercie de votre collaboration.

Appendix F – Background Information

City of Ottawa Vault Drawings (Plan and Profiles)

WATTS ACCUTROL Weir for Roof Drains

BOND ST.

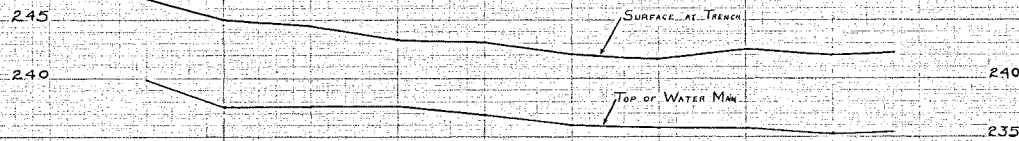
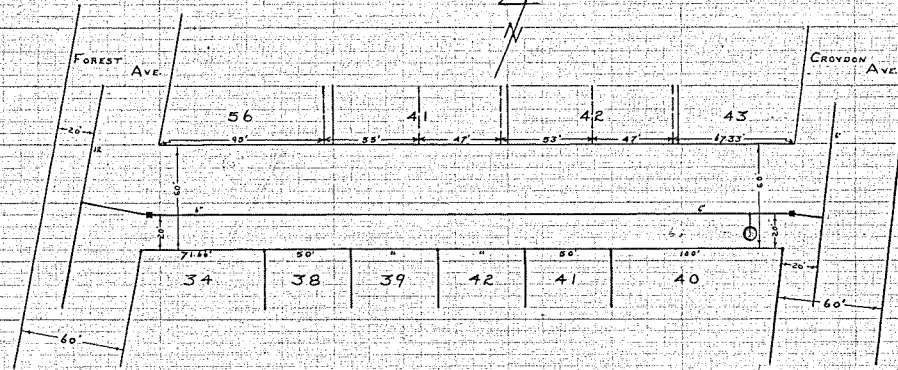

0-415-51/2" 20# @ Forest

0-04 1" VALVE
0-100

1-00

2-00

3-00

3-140 HYD 11" OFE WM

3-164 1" VALVE

3-186 1 1/2" 150# @ Crofton

CITY OF OTTAWA WATER WORKS DEPARTMENT	
6" WM INSTALLED ON BOND ST FROM FOREST AVE. TO CROFTON AVE.	
OWN BY <i>L. J. Irvine</i>	DATE: JAN 29/60
<i>P. S. Smith</i> ENGINEER	SCALE: HORIZ. 1" = 40'
<i>Atorney</i> DEPUTY COMMISSIONER	VERT. 1" = 10'
<i>H. S. Perkins</i> ENGINEER OF WATER WORKS	INSTALLED SEPT. 1959
	BOOK NO. 170

BOND STREET

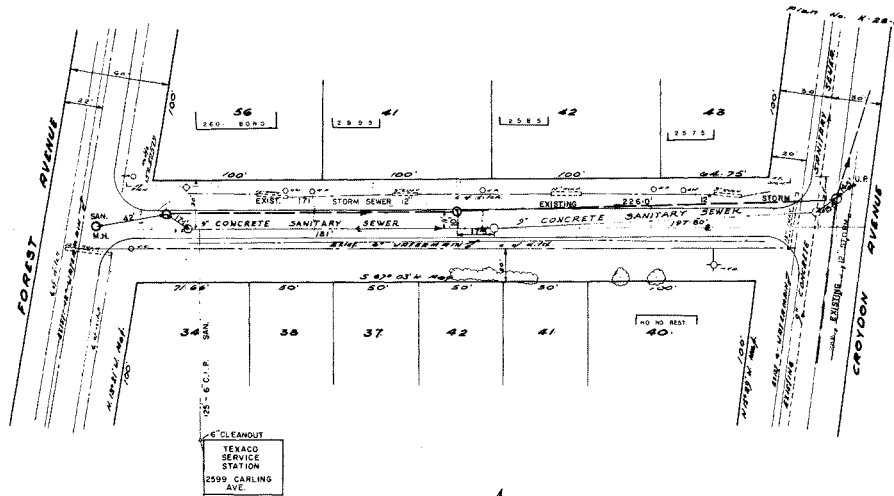

FINAL MEASUREMENT	
BOND STREET FROM CROYDON AVE.	FOR STORM SEWER TO FOREST AVE.
WORK START. OCT. 1, 74	DESIGNER K. SPERO
WORK COMP. OCT. 25, 74	CONTRACTOR HANSEN
FINAL MEAS. OCT. 24, 74	INSPECTOR E. CONNERS
FIELD BOOKS	INST MAN R. ST GERMAIN
DESIGN 3681	APPROVED BY D. SMALL
CONSTR. 3681	
FINAL MEAS. 3681	F. M. FOLDER 1309
TO ORIGINAL K. TOEG	DATE: DEC. 3, 1974

CITY OF OTTAWA DEPARTMENT OF PHYSICAL ENVIRONMENT SEWER SERVICES AND POLLUTION CONTROL BRANCH			
STORM SEWER			
BOND STREET			
DESIGNED BY K. C. SPERO	DRAWN BY P. HANSEN	SCALE HOB 1"=40'	VER. 17-8
CHECKED BY J. E. HANSEN	DATE APRIL, 3/74	FIELD BOOK 3681	PLAN NO.

NOTES
 REG'D PLAN NO. 15/11346
 APPROX. 1973/74. 12 PAGES.

NOTE
 UTILITIES SHOWN ARE TAKEN FROM THE BEST AVAILABLE RECORDS. CONTRACTORS ARE REQUESTED TO CHECK WITH ALL UTILITY COMPANIES BEFORE DIGGING. SOILS INFORMATION SHOWN IS NOT GUARANTEED AND CONTRACTORS ARE ADVISED TO COLLECT ADDITIONAL SOILS INFORMATION AS DEEMED NECESSARY.

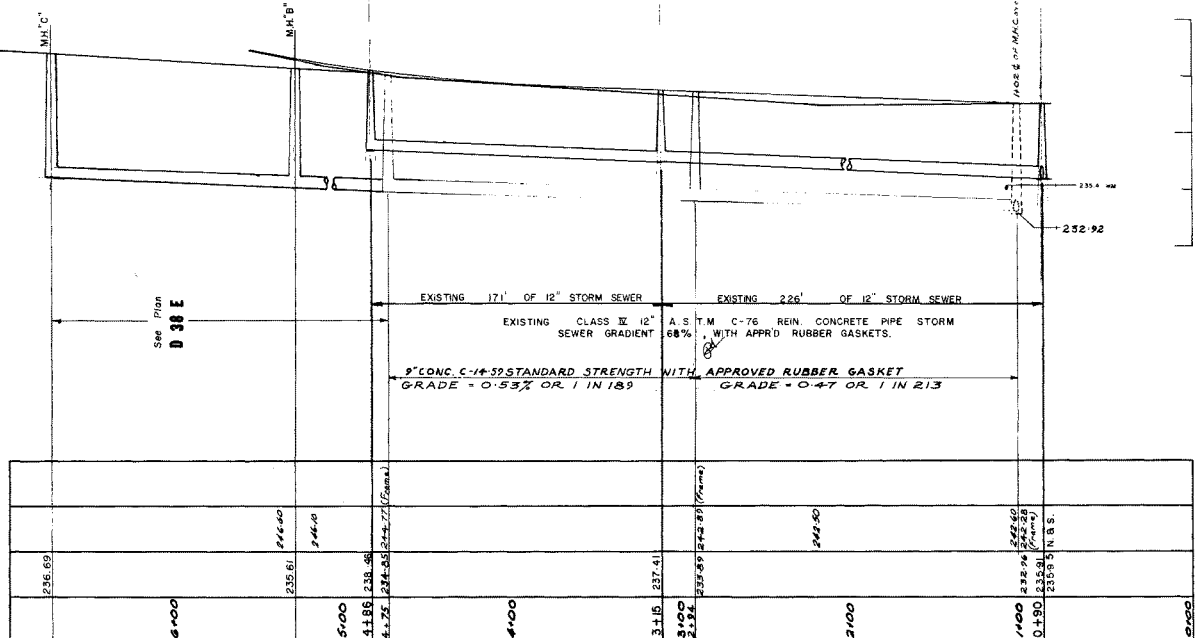

ELEVATION	HOUSE CONNECTIONS
250	
245	
240	
235	
230	
	HOUSE CONNECTIONS
	HOUSE LENGTH LOCATION
	2583 33' E/AA. 2+94
	2595 33' 88' W/AA. 2+74
	2601 33' 5' E/AA. 4+75

REVISIONS	
NO.	DESCRIPTION
1	SANITARY SEWER Work Commenced Nov 1961 Work Completed Nov 1961 Contractor Sparling Const Inspector A. Shields Final Measurements Dec 12/61 Book 3078 Page 28 Instrumentman D.R. McNab

ELEVATIONS	DESIGN BY DATE	
	ROAD GRADE	C. McComb
SURFACE		
INVERT		
STATION		

CITY OF OTTAWA PLANNING AND WORKS DEPARTMENT SEWERAGE AND DRAINAGE	
BOND STREET	
CROYDON AVE. TO FOREST AVENUE	
DRAWN BY R. HANSEN	SCALE HOB 1"=40'
CHECKED BY J. E. HANSEN	VER. 17-8
DATE APRIL, 3/74	PLAN NO.
FIELD BOOK 3681	E-32-2.

1082
 1082
 1082

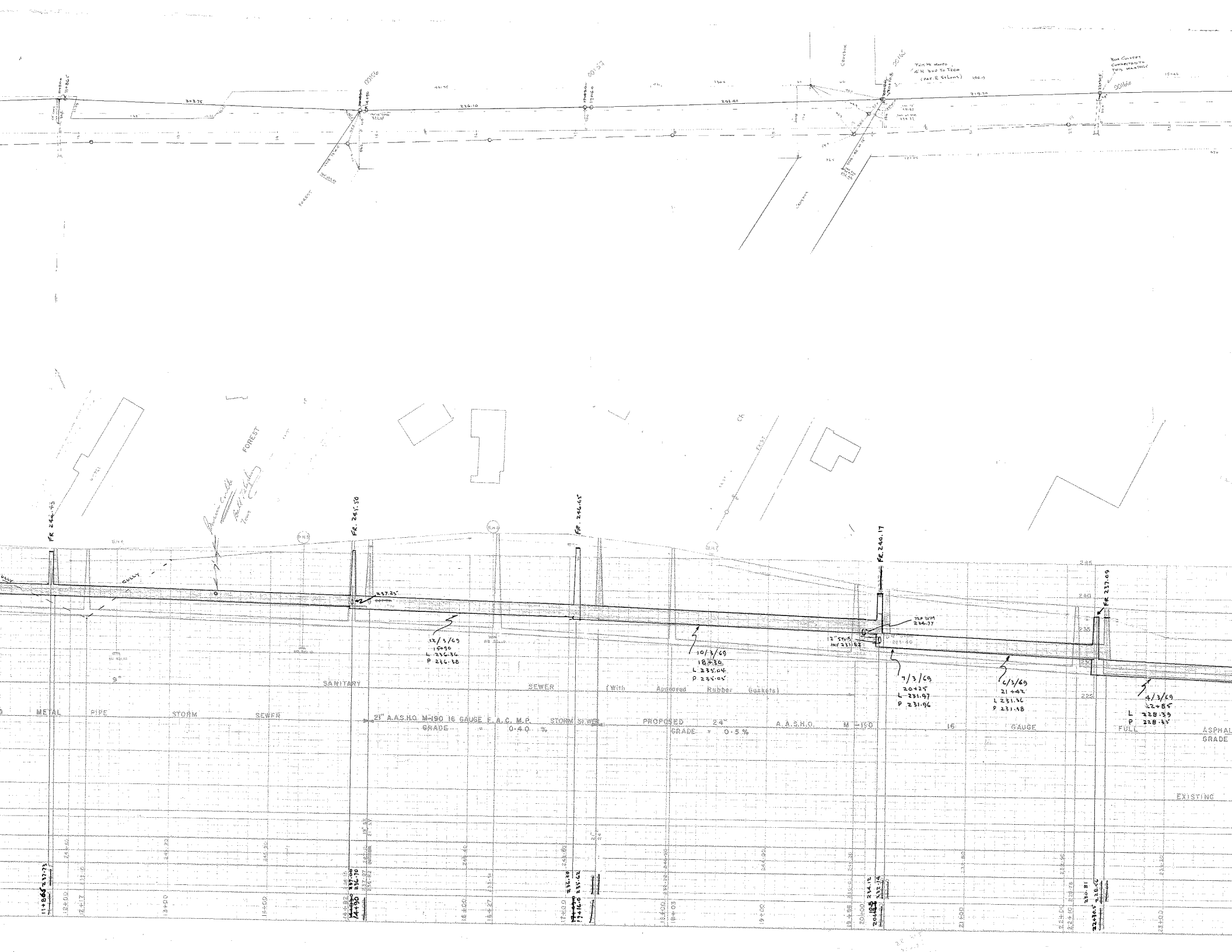



Adjustable Accutrol Weir

Tag: _____

Adjustable Flow Control for Roof Drains

ADJUSTABLE ACCUTROL (for Large Sump Roof Drains only)

For more flexibility in controlling flow with heads deeper than 2", Watts Drainage offers the Adjustable Accutrol. The Adjustable Accutrol Weir is designed with a single parabolic opening that can be covered to restrict flow above 2" of head to less than 5 gpm per inch, up to 6" of head. To adjust the flow rate for depths over 2" of head, set the slot in the adjustable upper cone according to the flow rate required. Refer to Table 1 below.
 Note: Flow rates are directly proportional to the amount of weir opening that is exposed.

EXAMPLE:

For example, if the adjustable upper cone is set to cover 1/2 of the weir opening, flow rates above 2" of head will be restricted to 2-1/2 gpm per inch of head.

Therefore, at 3" of head, the flow rate through the Accutrol Weir that has 1/2 the slot exposed will be:
 [5 gpm (per inch of head) x 2 inches of head] + 2-1/2 gpm (for the third inch of head) = 12-1/2 gpm.

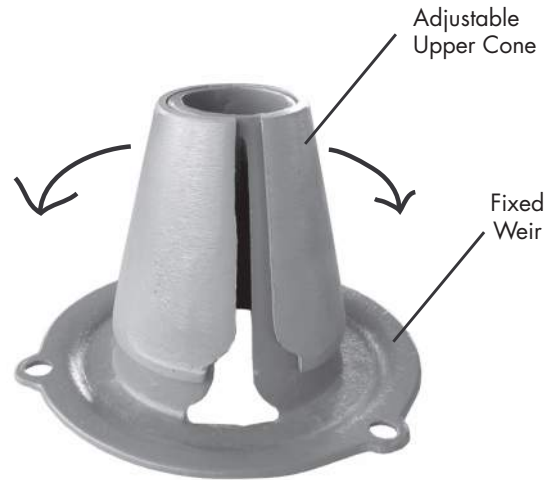
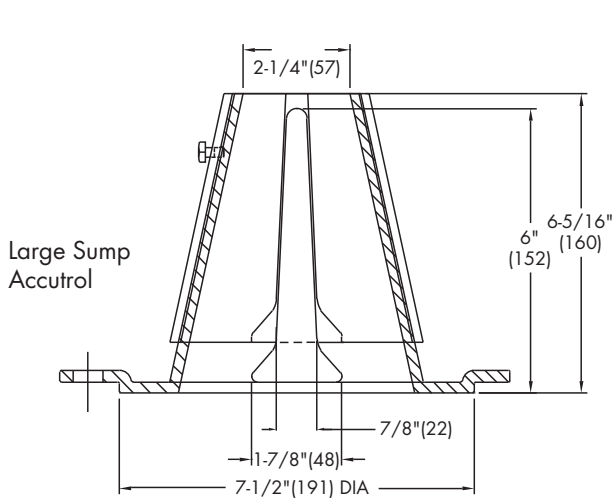

1/2 Weir Opening Exposed Shown Above

TABLE 1. Adjustable Accutrol Flow Rate Settings

Weir Opening Exposed	1"	2"	3"	4"	5"	6"
	Flow Rate (gallons per minute)					
Fully Exposed	5	10	15	20	25	30
3/4	5	10	13.75	17.5	21.25	25
1/2	5	10	12.5	15	17.5	20
1/4	5	10	11.25	12.5	13.75	15
Closed	5	5	5	5	5	5

Job Name _____
 Job Location _____
 Engineer _____

Contractor _____
 Contractor's P.O. No. _____
 Representative _____

Watts product specifications in U.S. customary units and metric are approximate and are provided for reference only. For precise measurements, please contact Watts Technical Service. Watts reserves the right to change or modify product design, construction, specifications, or materials without prior notice and without incurring any obligation to make such changes and modifications on Watts products previously or subsequently sold.

USA: Tel: (800) 338-2581 • Fax: (828) 248-3929 • Watts.com
 Canada: Tel: (905) 332-4090 • Fax: (905) 332-7068 • Watts.ca
 Latin America: Tel: (52) 81-1001-8600 • Fax: (52) 81-8000-7091 • Watts.com



A Watts Water Technologies Company

Appendix G – Checklist

GENERAL CONTENT		RESPONSE
<input type="checkbox"/>	Executive Summary (for larger reports only).	Not included
<input checked="" type="checkbox"/>	Date and revision number of the report.	Date of report provided
<input checked="" type="checkbox"/>	Location map and plan showing municipal address, boundary, and layout of proposed development.	Page 1 and Appendix G
<input checked="" type="checkbox"/>	Development statistics, land use, density, adherence to zoning and official plan, and reference to applicable subwatershed and watershed plans that provide context to which individual developments must adhere.	Section 2 of report
<input checked="" type="checkbox"/>	Summary of Pre-consultation Meetings with City and other approval agencies.	In Appendix E
<input type="checkbox"/>	Reference and confirm conformance to higher level studies and reports (Master Servicing Studies, Environmental Assessments, Community Design Plans), or in the case where it is not in conformance, the proponent must provide justification and develop a defensible design criteria.	No Master Servicing Studies.
<input checked="" type="checkbox"/>	Statement of objectives and servicing criteria.	Section 1 of report
<input checked="" type="checkbox"/>	Identification of existing and proposed infrastructure available in the immediate area.	Section 2 & 3 of report
<input type="checkbox"/>	Identification of Environmentally Significant Areas, watercourses and Municipal Drains potentially impacted by the proposed development (Reference can be made to the Natural Heritage Studies, if available).	Not applicable
<input type="checkbox"/>	Concept level master grading plan to confirm existing and proposed grades in the development. This is required to confirm the feasibility of proposed stormwater management and drainage, soil removal and fill constraints, and potential impacts to neighbouring properties. This is also required to confirm that the proposed grading will not impede existing major system flow paths.	Not applicable
<input type="checkbox"/>	Identification of potential impacts of proposed piped services on private services (such as wells and septic fields on adjacent lands) and mitigation required to address potential impacts.	Not applicable
<input type="checkbox"/>	Proposed phasing of the development, if applicable.	Not applicable
<input type="checkbox"/>	Reference to geotechnical studies and recommendations concerning servicing.	Not applicable
<input checked="" type="checkbox"/>	All preliminary and formal site plan submissions should have the following information: Metric scale North arrow (including construction North) Key plan name and contact information of applicant and property owner Property limits including bearings and dimensions Existing and proposed structures and parking areas Easements, road widening and rights-of-way Adjacent street names	Functional Report, Civil and Architectural Plans provided all this information.
DEVELOPMENT SERVICING REPORT: WATER		RESPONSE
<input type="checkbox"/>	Confirm consistency with Master Servicing Study, if available Availability of public infrastructure to service proposed development Identification of system constraints	Not applicable
<input checked="" type="checkbox"/>	Identify boundary conditions	Section 4.6
<input checked="" type="checkbox"/>	Confirmation of adequate domestic supply and pressure	Section 4.3
<input checked="" type="checkbox"/>	Confirmation of adequate fire flow protection and confirmation that fire flow is calculated as per the Fire Underwriter's Survey. Output should show available fire flow at locations throughout the development.	Section 4.7
<input checked="" type="checkbox"/>	Provide a check of high pressures. If pressure is found to be high, an assessment is required to confirm the application of pressure reducing valves.	Section 4.6 & Table B-5 Appendix B
<input type="checkbox"/>	Definition of phasing constraints. Hydraulic modeling is required to confirm servicing for all defined phases of the project including the ultimate design	Not applicable
<input checked="" type="checkbox"/>	Address reliability requirements such as appropriate location of shut-off valves Check on the necessity of a pressure zone boundary modification.	Section 4.3
<input checked="" type="checkbox"/>	Reference to water supply analysis to show that major infrastructure is capable of delivering sufficient water for the proposed land use. This includes data that shows that the expected demands under average day, peak hour and fire flow conditions provide water within the required pressure range	Section 4.5 & Table B-1 Appendix B
<input checked="" type="checkbox"/>	Description of the proposed water distribution network, including locations of proposed connections to the existing system, provisions for necessary looping, and appurtenances (valves, pressure reducing valves, valve chambers, and fire hydrants) including special metering provisions.	Section 4.2

<input type="checkbox"/>	Description of off-site required feeder mains, booster pumping stations, and other water infrastructure that will be ultimately required to service proposed development, including financing, interim facilities, and timing of implementation.	Not applicable
<input checked="" type="checkbox"/>	Confirmation that water demands are calculated based on the City of Ottawa Design Guidelines.	Table B-1 Appendix B
<input type="checkbox"/>	Provision of a model schematic showing the boundary conditions locations, streets, parcels, and building locations for reference.	Not applicable
DEVELOPMENT SERVICING REPORT: WASTEWATER		RESPONSE
<input checked="" type="checkbox"/>	Summary of proposed design criteria (Note: Wet-weather flow criteria should not deviate from the City of Ottawa Sewer Design Guidelines. Monitored flow data from relatively new infrastructure cannot be used to justify capacity requirements for proposed infrastructure).	Section 5.1
<input type="checkbox"/>	Confirm consistency with Master Servicing Study and/or justifications for deviations.	Not applicable
<input checked="" type="checkbox"/>	Consideration of local conditions that may contribute to extraneous flows that are higher than the recommended flows in the guidelines. This includes groundwater and soil conditions, and age and condition of sewers.	Section 5.2
<input checked="" type="checkbox"/>	Description of existing sanitary sewer available for discharge of wastewater from proposed development.	Section 5.2
<input type="checkbox"/>	Verify available capacity in downstream sanitary sewer and/or identification of upgrades necessary to service the proposed development. (Reference can be made to previously completed Master Servicing Study if applicable)	Not applicable
<input checked="" type="checkbox"/>	Calculations related to dry-weather and wet-weather flow rates from the development in standard MOE sanitary sewer design table (Appendix 'C') format.	Table C-6 in Appendix C
<input checked="" type="checkbox"/>	Description of proposed sewer network including sewers, pumping stations, and forcemains.	Section 5.2
<input type="checkbox"/>	Discussion of previously identified environmental constraints and impact on servicing (environmental constraints are related to limitations imposed on the development in order to preserve the physical condition of watercourses, vegetation, soil cover, as well as protecting against water quantity and quality).	Not applicable
<input type="checkbox"/>	Pumping stations: impacts of proposed development on existing pumping stations or requirements for new pumping station to service development.	Not applicable
<input type="checkbox"/>	Forcemain capacity in terms of operational redundancy, surge pressure and maximum flow velocity.	Not applicable
<input type="checkbox"/>	Identification and implementation of the emergency overflow from sanitary pumping stations in relation to the hydraulic grade line to protect against basement flooding.	Not applicable
<input type="checkbox"/>	Special considerations such as contamination, corrosive environment etc.	Not applicable
DEVELOPMENT SERVICING REPORT: STORMWATER CHECKLIST		RESPONSE
<input checked="" type="checkbox"/>	Description of drainage outlets and downstream constraints including legality of outlets (i.e. municipal drain, right-of-way, watercourse, or private property)	Section 6
<input type="checkbox"/>	Analysis of available capacity in existing public infrastructure.	Not applicable
<input checked="" type="checkbox"/>	A drawing showing the subject lands, its surroundings, the receiving watercourse, existing drainage patterns, and proposed drainage pattern.	Figure A-1 & A-2
<input type="checkbox"/>	Water quantity control objective (e.g. controlling post-development peak flows to pre-development level for storm events ranging from the 2 or 5 year event (dependent on the receiving sewer design) to 100 year return period); if other objectives are being applied, a rationale must be included with reference to hydrologic analyses of the potentially affected subwatersheds, taking into account long-term cumulative effects.	Not Applicable
<input type="checkbox"/>	Water Quality control objective (basic, normal or enhanced level of protection based on the sensitivities of the receiving watercourse) and storage requirements.	Not Applicable
<input checked="" type="checkbox"/>	Description of the stormwater management concept with facility locations and descriptions with references and supporting information.	Section 6.2 & 6.3
<input type="checkbox"/>	Set-back from private sewage disposal systems. Watercourse and hazard lands setbacks.	Not Applicable
<input checked="" type="checkbox"/>	Record of pre-consultation with the Ontario Ministry of Environment and the Conservation Authority that has jurisdiction on the affected watershed.	Appendix E
<input type="checkbox"/>	Confirm consistency with sub-watershed and Master Servicing Study, if applicable study exists.	Not Applicable
<input checked="" type="checkbox"/>	Storage requirements (complete with calculations) and conveyance capacity for minor events (1:5 year return period) and major events (1:100 year return period).	Section 6.9 & Table D12-D16 of Appendix D

<input type="checkbox"/>	Identification of watercourses within the proposed development and how watercourses will be protected, or, if necessary, altered by the proposed development with applicable approvals.	Not Applicable
<input checked="" type="checkbox"/>	Calculate pre and post development peak flow rates including a description of existing site conditions and proposed impervious areas and drainage catchments in comparison to existing conditions.	Section 6.6, 6.8 & Table D-8 & D11 of Appendix D
<input type="checkbox"/>	Any proposed diversion of drainage catchment areas from one outlet to another.	Not Applicable
<input checked="" type="checkbox"/>	Proposed minor and major systems including locations and sizes of stormwater trunk sewers, and stormwater management facilities.	Section 6.8
<input type="checkbox"/>	If quantity control is not proposed, demonstration that downstream system has adequate capacity for the post-development flows up to and including the 100-year return period storm event.	Not Applicable
<input type="checkbox"/>	Identification of potential impacts to receiving watercourses Identification of municipal drains and related approval requirements.	Not Applicable
<input checked="" type="checkbox"/>	Descriptions of how the conveyance and storage capacity will be achieved for the development.	Section 6.9
<input checked="" type="checkbox"/>	100-year flood levels and major flow routing to protect proposed development from flooding for establishing minimum building elevations (MBE) and overall grading.	Grading Plan
<input type="checkbox"/>	Inclusion of hydraulic analysis including hydraulic grade line elevations.	Not Applicable
<input checked="" type="checkbox"/>	Description of approach to erosion and sediment control during construction for the protection of receiving watercourse or drainage corridors.	Section 7
<input type="checkbox"/>	Identification of floodplains – proponent to obtain relevant floodplain information from the appropriate Conservation Authority. The proponent may be required to delineate floodplain elevations to the satisfaction of the Conservation Authority if such information is not available or if information does not match current conditions.	Not Applicable – No requirements from Conservation Authority
<input type="checkbox"/>	Identification of fill constraints related to floodplain and geotechnical investigation.	See geotechnical report
<input checked="" type="checkbox"/>	The Servicing Study shall provide a list of applicable permits and regulatory approvals necessary for the proposed development as well as the relevant issues affecting each approval. The approval and permitting shall include but not be limited to the following:	Appendix E
<input type="checkbox"/>	Conservation Authority as the designated approval agency for modification of floodplain, potential impact on fish habitat, proposed works in or adjacent to a watercourse, cut/fill permits and Approval under Lakes and Rivers Improvement Act. The Conservation Authority is not the approval authority for the Lakes and Rivers Improvement Act. Where there are Conservation Authority regulations in place, approval under the Lakes and Rivers Improvement Act is not required, except in cases of dams as defined in the Act.	Not Applicable
<input type="checkbox"/>	Application for Certificate of Approval (CofA) under the Ontario Water Resources Act.	Not Applicable
<input type="checkbox"/>	Changes to Municipal Drains.	Not Applicable
<input type="checkbox"/>	Other permits (National Capital Commission, Parks Canada, Public Works and Government Services Canada, Ministry of Transportation etc.)	Not Applicable
CONCLUSION CHECKLIST		RESPONSE
<input checked="" type="checkbox"/>	Clearly stated conclusions and recommendations	In Section 8
<input checked="" type="checkbox"/>	Comments received from review agencies including the City of Ottawa and information on how the comments were addressed. Final sign-off from the responsible reviewing agency.	Appendix E
<input checked="" type="checkbox"/>	All draft and final reports shall be signed and stamped by a professional Engineer registered in Ontario	Signed and stamped

Appendix H – Drawings

Site Plan and Renderings (11 pages)

Civil Engineering Design Drawings by EXP (separate)

Mechanical Plans and Details of Oil Grit Separator

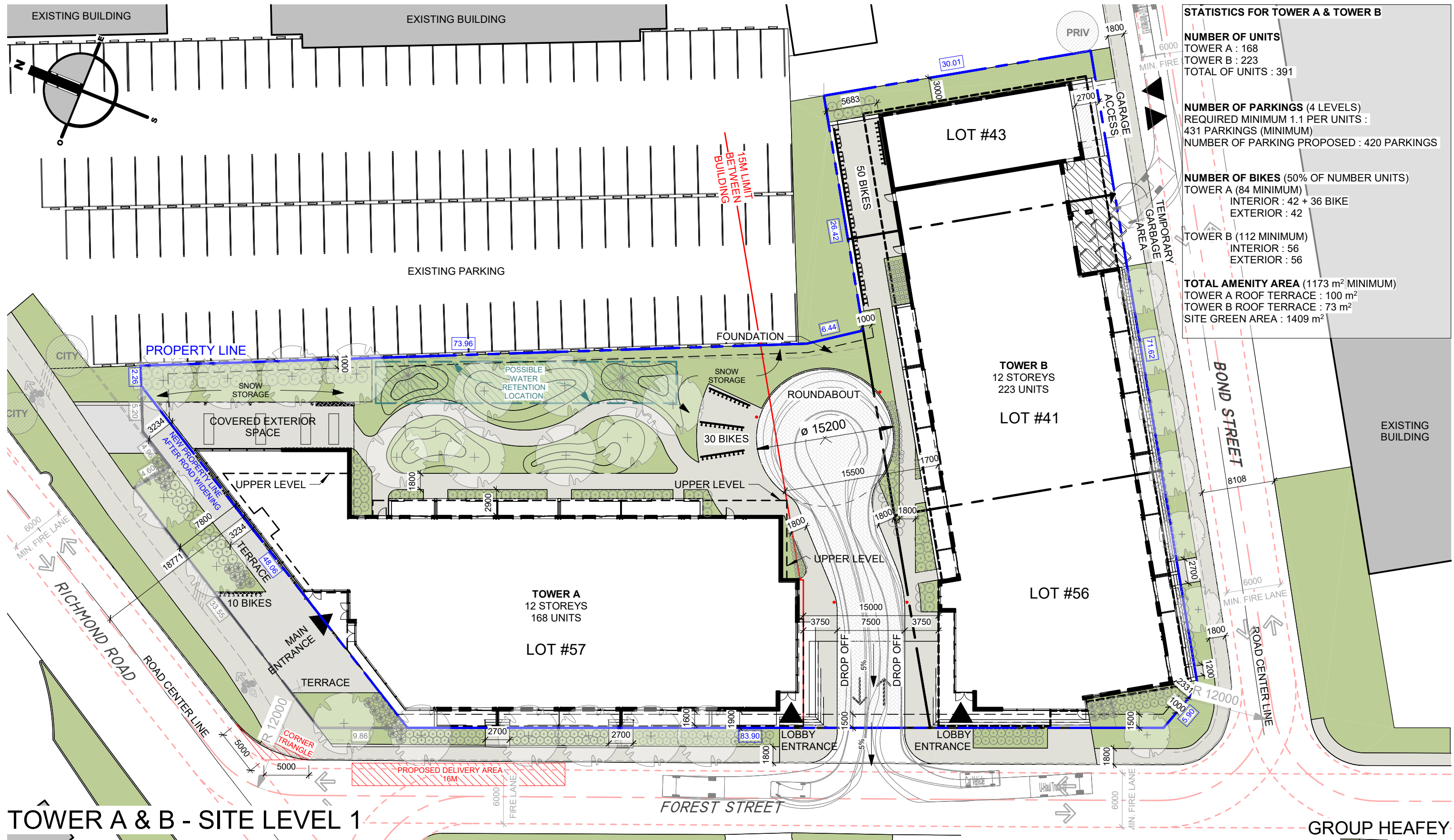

STATISTICS FOR TOWER A & TOWER B

NUMBER OF UNITS
 TOWER A : 168
 TOWER B : 223
 TOTAL OF UNITS : 391

NUMBER OF PARKINGS (4 LEVELS)
 REQUIRED MINIMUM 1.1 PER UNITS :
 431 PARKINGS (MINIMUM)
 NUMBER OF PARKING PROPOSED : 420 PARKINGS

NUMBER OF BIKES (50% OF NUMBER UNITS)
 TOWER A (84 MINIMUM)
 INTERIOR : 42 + 36 BIKE
 EXTERIOR : 42
 TOWER B (112 MINIMUM)
 INTERIOR : 56
 EXTERIOR : 56

TOTAL AMENITY AREA (1173 m² MINIMUM)
 TOWER A ROOF TERRACE : 100 m²
 TOWER B ROOF TERRACE : 73 m²
 SITE GREEN AREA : 1409 m²

TOWER A & B - SITE LEVEL 1

GROUP HEAFEY

365 Forest Street, Ottawa, ON K2B 7Z7

1 : 400



Dessiné par : Tanya Nadeau
 Conçu par : Christian Rheault

53 blvd Saint-Raymond, Suite 200-A
 Gatineau, QC J8Y 1R8
 www.lrarch.ca



1887-2303-19

A02

D07-12-20-0041

2021.10.26

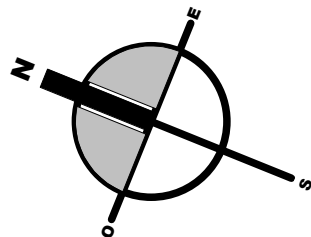

P1 PARKING
NUMBER OF PARKING : 87 SPACES

P2 PARKING
NUMBER OF PARKING : 111 SPACES

P3 PARKING
NUMBER OF PARKING : 111 SPACES

P4 PARKING
NUMBER OF PARKING : 111 SPACES

SPECIFIC TYPE OF PARKING :

STANDARD : 361
VISITOR : 33
UNIVERSAL : 11
ELECTRIC : 15

BIKES : 36

TOTAL : 420 SPACES
(REQUIRED MINIMUM 431 SPACES)

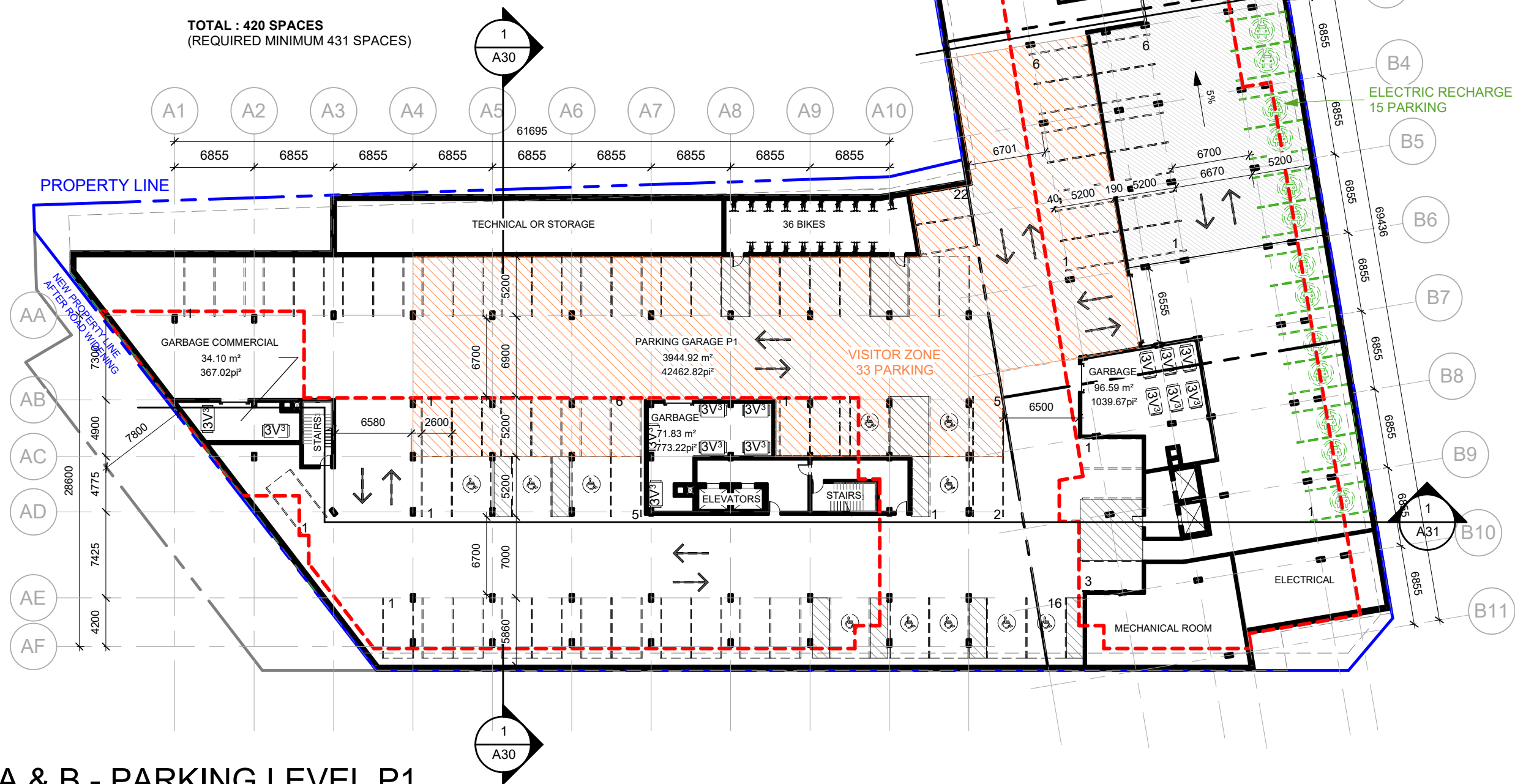

TOWER A & B - PARKING LEVEL P1

GROUP HEAFEY

365 Forest Street, Ottawa, ON K2B 7Z7

1 : 400



Dessiné par : Tanya Nadeau
Conçu par : Christian Rheault

53 blvd Saint-Raymond, Suite 200-A
Gatineau, QC J8Y 1R8
www.lrarch.ca



1887-2303-19

A04

D07-12-20-0041

2021.10.26



BALCONY AREA LEVEL 1 : 102 m² / 9 UNITS = 11.33 m²

GROSS AREA LEGEND



TOWER A - LEVEL 1

GROUP HEAFEY



Dessiné par : Tanya Nadeau
 Conçu par : Christian Rheault
 53 blvd Saint-Raymond, Suite 200-A
 Gatineau, QC J8Y 1R8
 www.lrarch.ca



365 Forest Street, Ottawa, ON K2B 7Z7

1 : 200

1887-2303-19

A09

D07-12-20-0041

2021.10.26

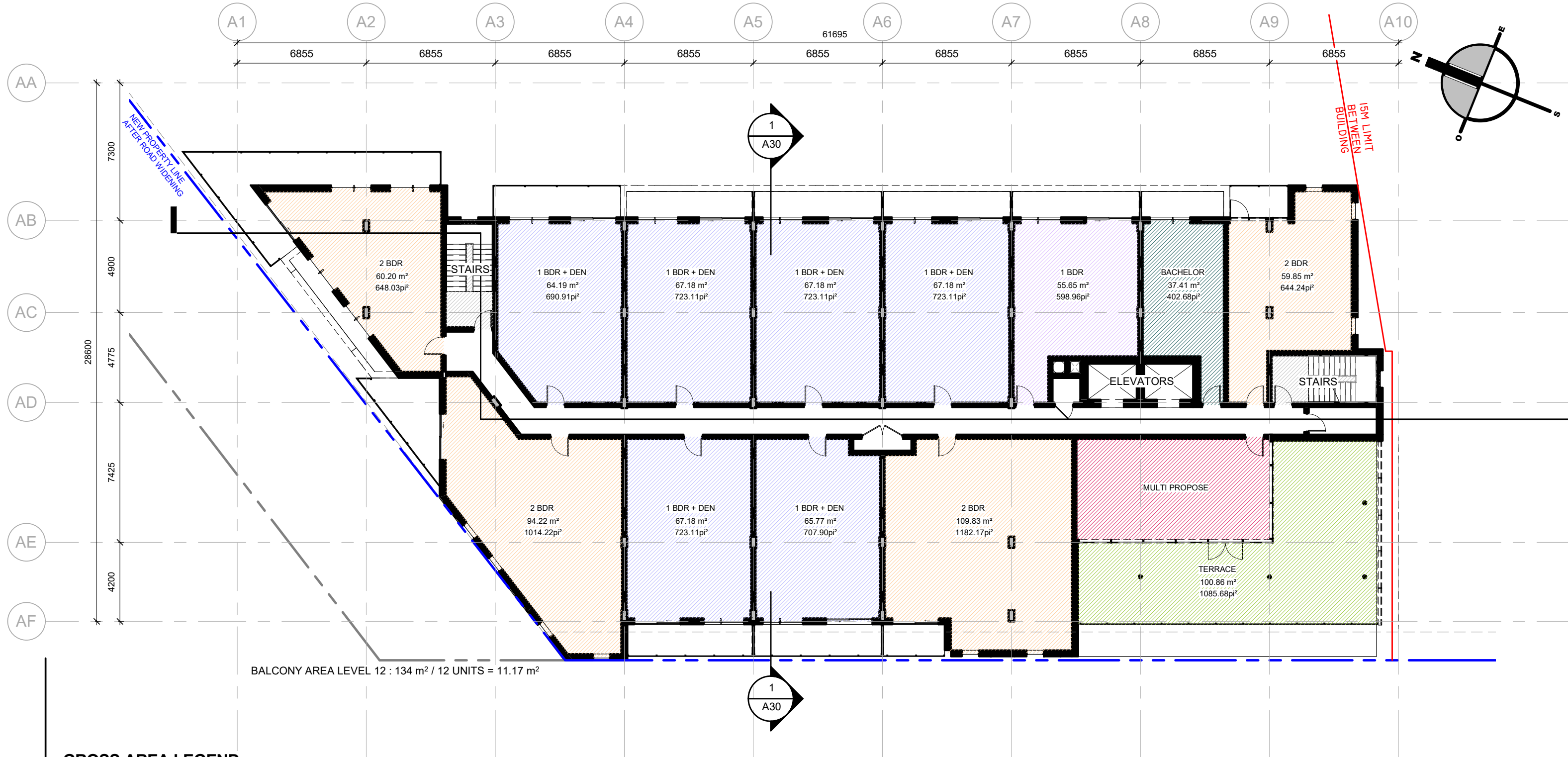

GROSS AREA LEGEND



TOWER A - LEVEL 12

GROUP HEAFEY



Dessiné par : Tanya Nadeau
Conçu par : Christian Rheault

53 blvd Saint-Raymond, Suite 200-A
Gatineau, QC J8Y 1R8
www.lrarch.ca



365 Forest Street, Ottawa, ON K2B 7Z7

1 : 200

1887-2303-19

A14

D07-12-20-0041

2021.10.26

ROOM TYPOLOGY - TOWER A		
LEVEL	NAME	QTY
LEVEL 1	1 BDR	1
LEVEL 1	1 BDR + DEN	6
LEVEL 1	2 BDR	2
LEVEL 2	1 BDR	2
LEVEL 2	1 BDR + DEN	9
LEVEL 2	BACHELOR	1
LEVEL 3	1 BDR	1
LEVEL 3	1 BDR + DEN	9
LEVEL 3	2 BDR	4
LEVEL 3	BACHELOR	1
LEVEL 4	1 BDR	1
LEVEL 4	1 BDR + DEN	9
LEVEL 4	2 BDR	4
LEVEL 4	BACHELOR	1
LEVEL 5	1 BDR	1
LEVEL 5	1 BDR + DEN	9
LEVEL 5	2 BDR	4
LEVEL 5	BACHELOR	1
LEVEL 6	1 BDR	1
LEVEL 6	1 BDR + DEN	9
LEVEL 6	2 BDR	4
LEVEL 6	BACHELOR	1
LEVEL 7	1 BDR	1
LEVEL 7	1 BDR + DEN	9
LEVEL 7	2 BDR	4
LEVEL 7	BACHELOR	1
LEVEL 8	1 BDR	1
LEVEL 8	1 BDR + DEN	9
LEVEL 8	2 BDR	4
LEVEL 8	BACHELOR	1
LEVEL 9	1 BDR	1
LEVEL 9	1 BDR + DEN	9
LEVEL 9	2 BDR	4
LEVEL 9	BACHELOR	1
LEVEL 10	1 BDR	1
LEVEL 10	1 BDR + DEN	9
LEVEL 10	2 BDR	4
LEVEL 10	BACHELOR	1
LEVEL 11	1 BDR	1
LEVEL 11	1 BDR + DEN	9
LEVEL 11	2 BDR	4
LEVEL 11	BACHELOR	1
LEVEL 12	1 BDR	1
LEVEL 12	1 BDR + DEN	6
LEVEL 12	2 BDR	4
LEVEL 12	BACHELOR	1
TOTAL UNITS: 168		

1 BDR - TOWER A		
NIVEAU	NOM	NOMBRE
LEVEL 1	1 BDR	1
LEVEL 2	1 BDR	2
LEVEL 3	1 BDR	1
LEVEL 4	1 BDR	1
LEVEL 5	1 BDR	1
LEVEL 6	1 BDR	1
LEVEL 7	1 BDR	1
LEVEL 8	1 BDR	1
LEVEL 9	1 BDR	1
LEVEL 10	1 BDR	1
LEVEL 11	1 BDR	1
LEVEL 12	1 BDR	1
TOTAL: 13		

2 BDR - TOWER A		
NIVEAU	NOM	NOMBRE
LEVEL 1	2 BDR	2
LEVEL 3	2 BDR	4
LEVEL 4	2 BDR	4
LEVEL 5	2 BDR	4
LEVEL 6	2 BDR	4
LEVEL 7	2 BDR	4
LEVEL 8	2 BDR	4
LEVEL 9	2 BDR	4
LEVEL 10	2 BDR	4
LEVEL 11	2 BDR	4
LEVEL 12	2 BDR	4
TOTAL: 42		

TYPOLOGY - TOWER A		
NOM	NOMBRE	%
1 BDR	13	7%
1 BDR + DEN	102	61%
2 BDR	42	28%
BACHELOR	11	4%
TOTAL DE LOGEMENTS: 168		100%

1 BDR + DEN - TOWER A		
NIVEAU	NOM	NOMBRE
LEVEL 1	1 BDR + DEN	6
LEVEL 2	1 BDR + DEN	9
LEVEL 3	1 BDR + DEN	9
LEVEL 4	1 BDR + DEN	9
LEVEL 5	1 BDR + DEN	9
LEVEL 6	1 BDR + DEN	9
LEVEL 7	1 BDR + DEN	9
LEVEL 8	1 BDR + DEN	9
LEVEL 9	1 BDR + DEN	9
LEVEL 10	1 BDR + DEN	9
LEVEL 11	1 BDR + DEN	9
LEVEL 12	1 BDR + DEN	6
TOTAL: 102		

2 BDR + DEN - TOWER A		
NIVEAU	NOM	NOMBRE

GROUP HEAFEY

365 Forest Street, Ottawa, ON K2B 7Z7



Dessiné par : Tanya Nadeau
 Conçu par : Christian Rheault

53 blvd Saint-Raymond, Suite 200-A
 Gatineau, QC J8Y 1R8
 www.lrarch.ca



1887-2303-19

A16

D07-12-20-0041

2021.10.26

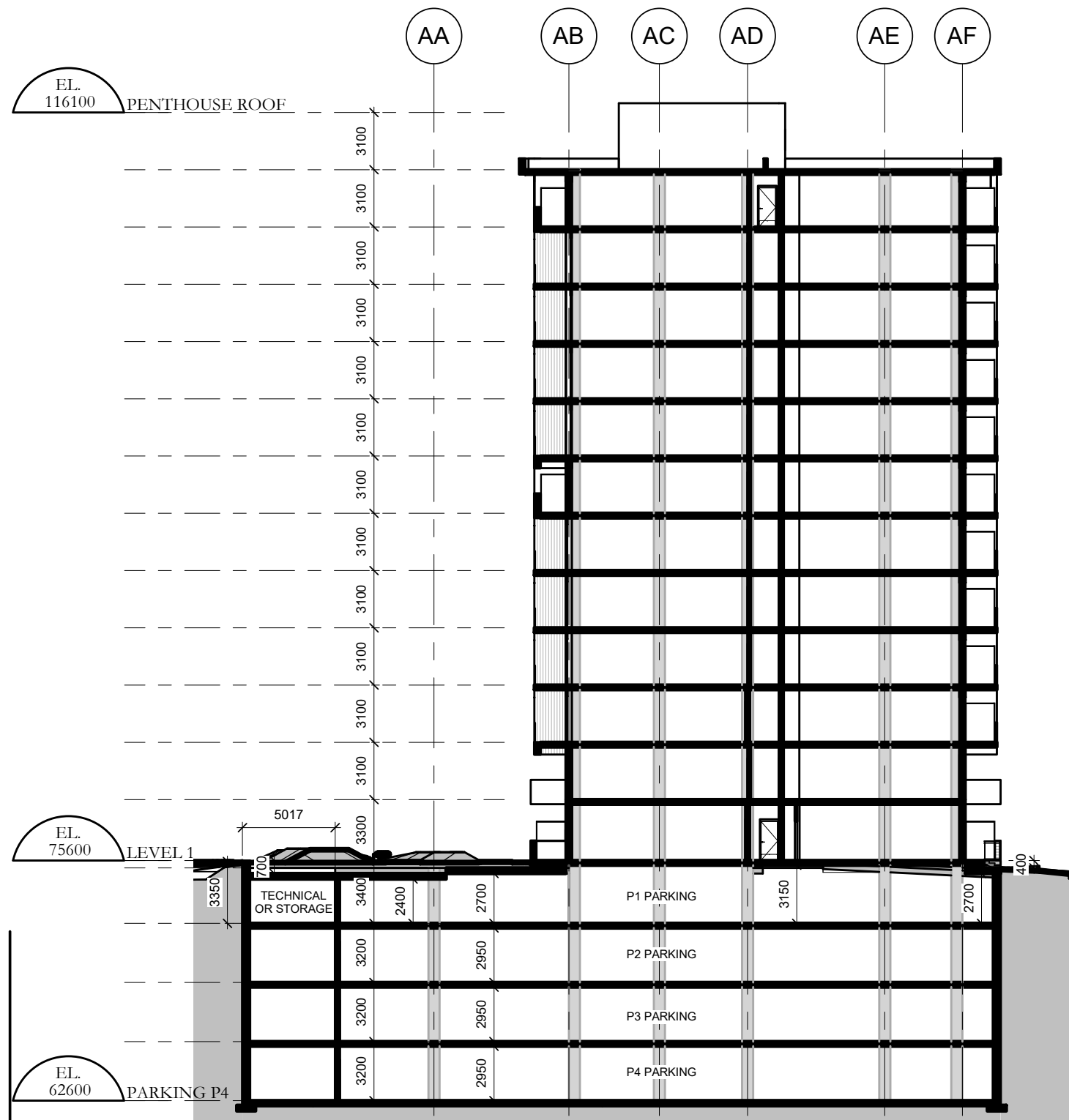

TOWER A - SECTION

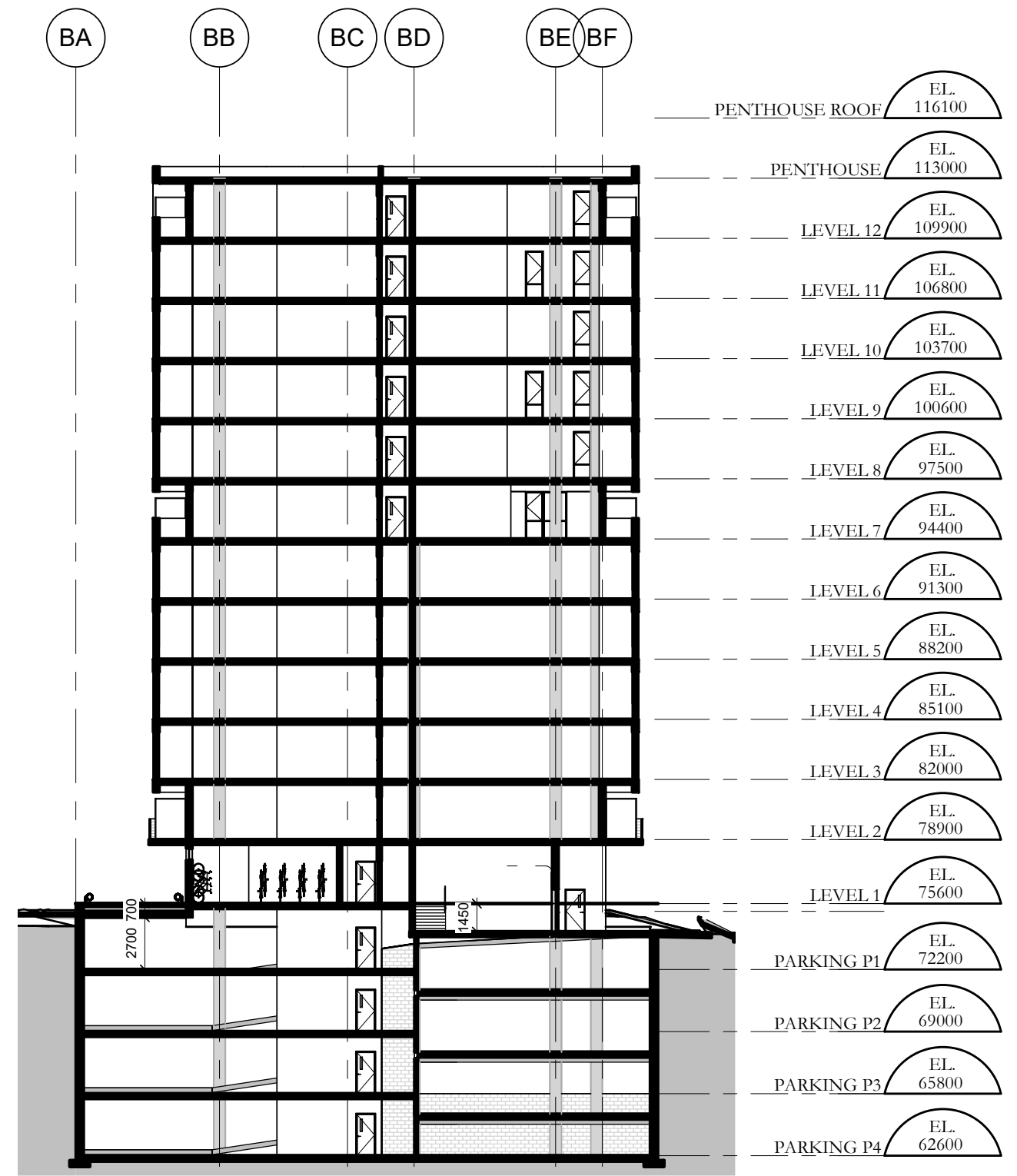

TOWER B - SECTION

GROUP HEAFEY

365 Forest Street, Ottawa, ON K2B 7Z7

1 : 300

1887-2303-19

A30

D07-12-20-0041

2021.10.26



Dessiné par : Tanya Nadeau
 Conçu par : Christian Rheault

53 blvd Saint-Raymond, Suite 200-A
 Gatineau, QC J8Y 1R8
 www.lrarch.ca





TOWER A & B - SECTION

GROUP HEAFEY

365 Forest Street, Ottawa, ON K2B 7Z7

1 : 300

1887-2303-19

A31

D07-12-20-0041

2021.10.26



Dessiné par : Tanya Nadeau
 Conçu par : Christian Rheault

53 blvd Saint-Raymond, Suite 200-A
 Gatineau, QC J8Y 1R8
 www.lrarch.ca



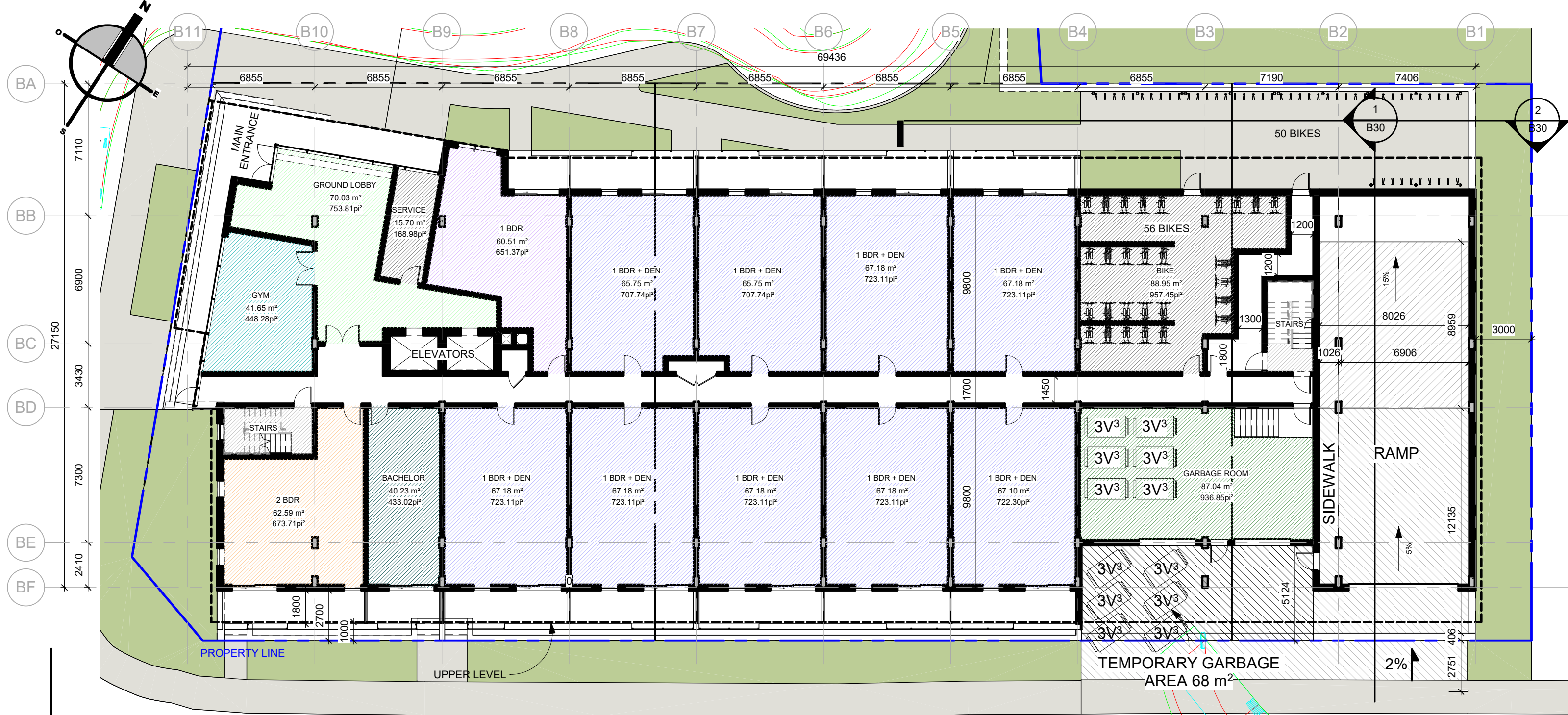

GROSS AREA LEGEND



TOWER B - LEVEL 1

GROUP HEAFEY

365 Forest Street, Ottawa, ON K2B 7Z7

1 : 200

1887-2303-19

B02

D07-12-20-0041

2021.10.26



Dessiné par : Tanya Nadeau
 Conçu par : Christian Rheault
 53 blvd Saint-Raymond, Suite 200-A
 Gatineau, QC J8Y 1R8
 www.lrarch.ca



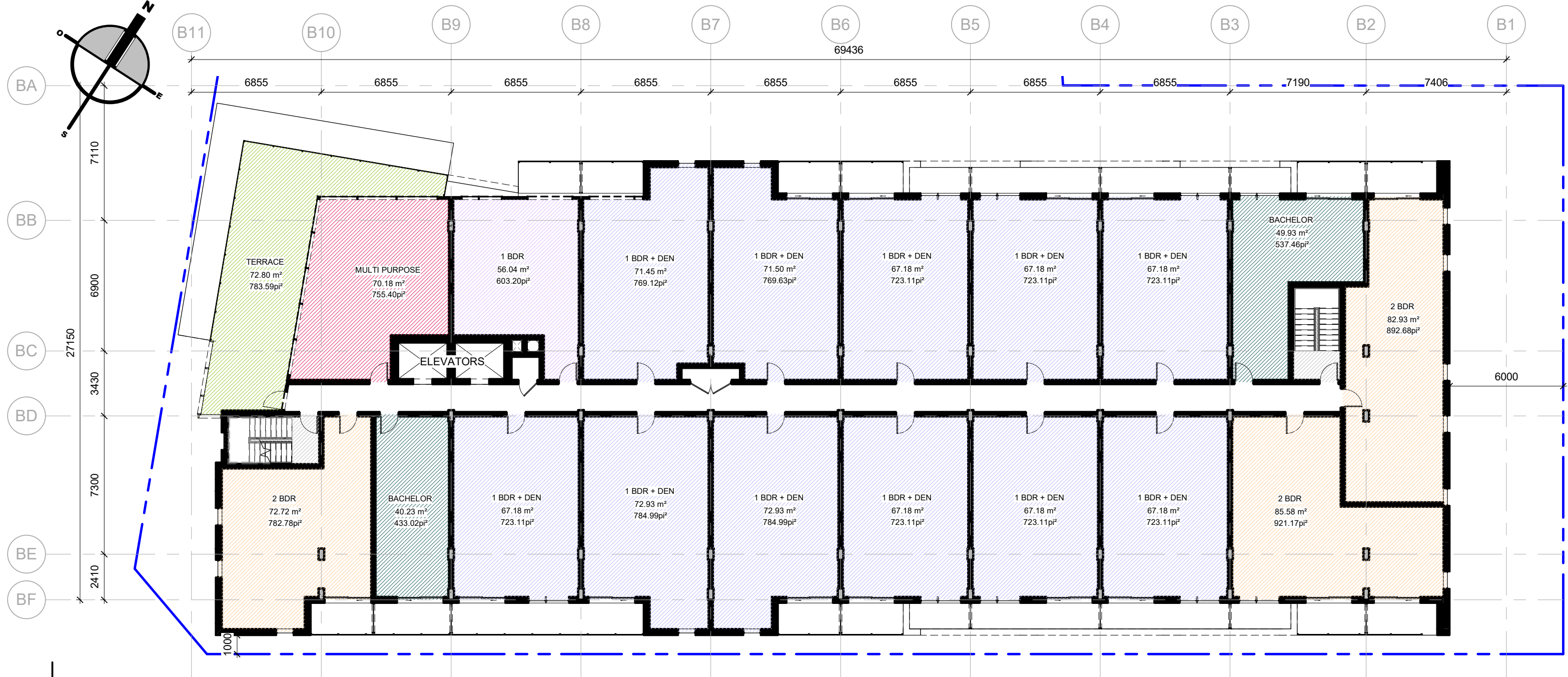

GROSS AREA LEGEND



BALCONY AREA LEVEL 12 : 144 m² / 17 UNITS = 8.47 m²

TOWER B - LEVEL 12

GROUP HEAFEY



Dessiné par : Tanya Nadeau
 Conçu par : Christian Rheault
 53 blvd Saint-Raymond, Suite 200-A
 Gatineau, QC J8Y 1R8
 www.lrarch.ca



365 Forest Street, Ottawa, ON K2B 2Z7
 1 : 200
 1887-2303-19
 B07
 D07-12-20-0041
 2021.10.26

ROOM TYPOLOGY - TOWER B		
LEVEL	NAME	QTY
LEVEL 1	1 BDR	1
LEVEL 1	1 BDR + DEN	9
LEVEL 1	2 BDR	1
LEVEL 1	BACHELOR	1
LEVEL 2	1 BDR	1
LEVEL 2	1 BDR + DEN	13
LEVEL 2	2 BDR	3
LEVEL 2	BACHELOR	2
LEVEL 3	1 BDR	1
LEVEL 3	1 BDR + DEN	13
LEVEL 3	2 BDR	4
LEVEL 3	BACHELOR	2
LEVEL 4	1 BDR	1
LEVEL 4	1 BDR + DEN	13
LEVEL 4	2 BDR	4
LEVEL 4	BACHELOR	2
LEVEL 5	1 BDR	1
LEVEL 5	1 BDR + DEN	13
LEVEL 5	2 BDR	4
LEVEL 5	BACHELOR	2
LEVEL 6	1 BDR	1
LEVEL 6	1 BDR + DEN	13
LEVEL 6	2 BDR	4
LEVEL 6	BACHELOR	2
LEVEL 7	1 BDR	1
LEVEL 7	1 BDR + DEN	12
LEVEL 7	2 BDR	4
LEVEL 7	BACHELOR	2
LEVEL 8	1 BDR	1
LEVEL 8	1 BDR + DEN	12
LEVEL 8	2 BDR	4
LEVEL 8	BACHELOR	2
LEVEL 9	1 BDR	1
LEVEL 9	1 BDR + DEN	12
LEVEL 9	2 BDR	4
LEVEL 9	BACHELOR	2
LEVEL 10	1 BDR	1
LEVEL 10	1 BDR + DEN	12
LEVEL 10	2 BDR	4
LEVEL 10	BACHELOR	2
LEVEL 11	1 BDR	1
LEVEL 11	1 BDR + DEN	12
LEVEL 11	2 BDR	4
LEVEL 11	BACHELOR	2
LEVEL 12	1 BDR	1
LEVEL 12	1 BDR + DEN	11
LEVEL 12	2 BDR	3
LEVEL 12	BACHELOR	2
TOTAL DE LOGEMENTS: 223		

1 BDR - TOWER B		
LEVEL	NAME	QTY
LEVEL 1	1 BDR	1
LEVEL 2	1 BDR	1
LEVEL 3	1 BDR	1
LEVEL 4	1 BDR	1
LEVEL 5	1 BDR	1
LEVEL 6	1 BDR	1
LEVEL 7	1 BDR	1
LEVEL 8	1 BDR	1
LEVEL 9	1 BDR	1
LEVEL 10	1 BDR	1
LEVEL 11	1 BDR	1
LEVEL 12	1 BDR	1
TOTAL: 12		

2 BDR - TOWER B		
LEVEL	NAME	QTY
LEVEL 1	2 BDR	1
LEVEL 2	2 BDR	3
LEVEL 3	2 BDR	4
LEVEL 4	2 BDR	4
LEVEL 5	2 BDR	4
LEVEL 6	2 BDR	4
LEVEL 7	2 BDR	4
LEVEL 8	2 BDR	4
LEVEL 9	2 BDR	4
LEVEL 10	2 BDR	4
LEVEL 11	2 BDR	4
LEVEL 12	2 BDR	3
TOTAL: 43		

TYPOLOGY - TOWER B		
NAME	QTY	%
1 BDR	12	5%
1 BDR + DEN	145	66%
2 BDR	43	22%
BACHELOR	23	7%
TOTAL DE LOGEMENTS: 223		100%

1 BDR + DEN - TOWER B		
LEVEL	NAME	QTY
LEVEL 1	1 BDR + DEN	9
LEVEL 2	1 BDR + DEN	13
LEVEL 3	1 BDR + DEN	13
LEVEL 4	1 BDR + DEN	13
LEVEL 5	1 BDR + DEN	13
LEVEL 6	1 BDR + DEN	13
LEVEL 7	1 BDR + DEN	12
LEVEL 8	1 BDR + DEN	12
LEVEL 9	1 BDR + DEN	12
LEVEL 10	1 BDR + DEN	12
LEVEL 11	1 BDR + DEN	12
LEVEL 12	1 BDR + DEN	11
TOTAL: 145		

2 BDR + DEN - TOWER B		
LEVEL	NAME	QTY

GROUP HEAFEY

365 Forest Street, Ottawa, ON K2B 7Z7



Dessiné par : Tanya Nadeau
 Conçu par : Christian Rheault

53 blvd Saint-Raymond, Suite 200-A
 Gatineau, QC J8Y 1R8
 www.lrarch.ca



ESQUISSE
 1887-2303-19

B09
 D07-12-20-0041

2021.10.26

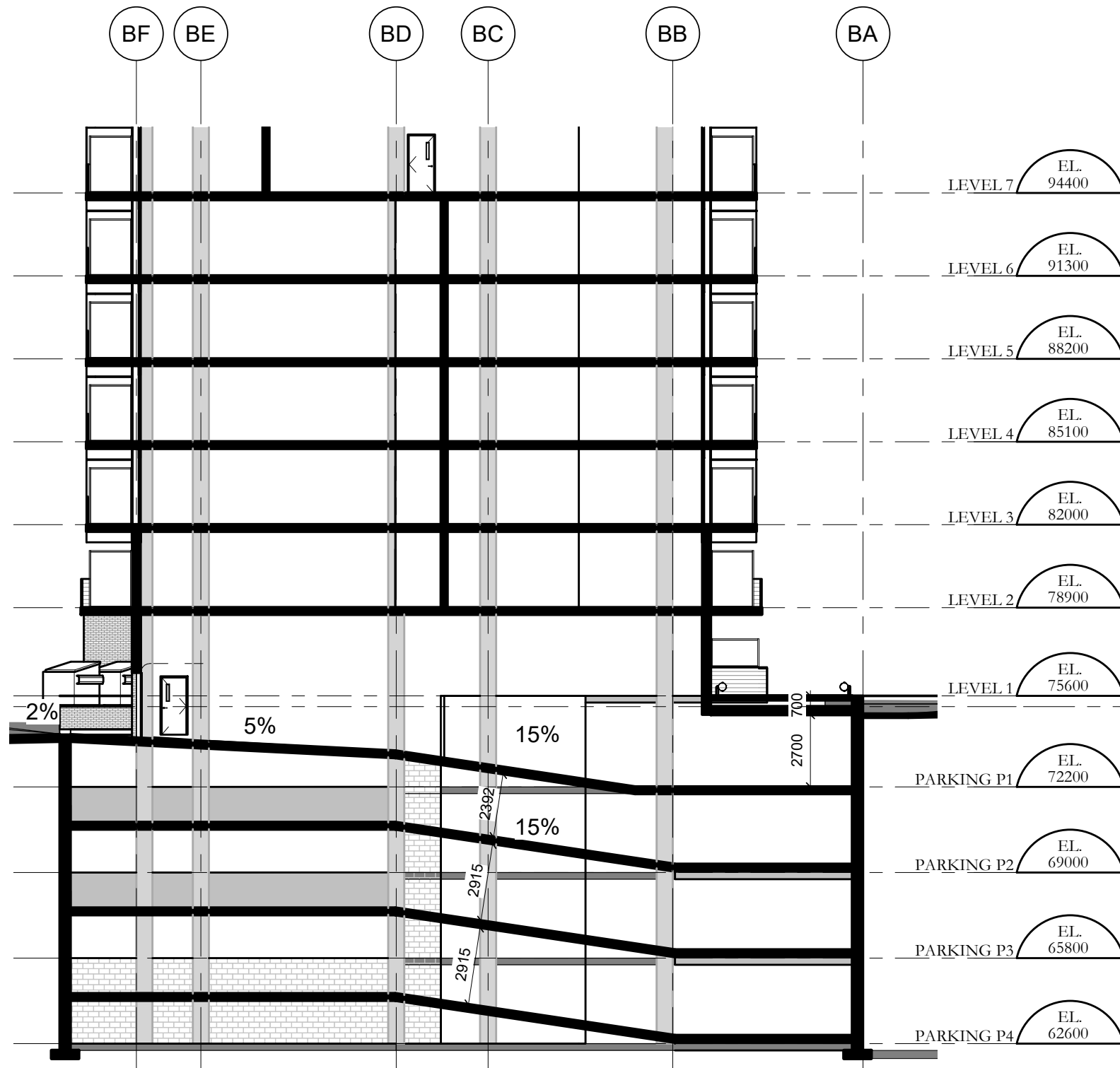

TOWER B - SECTION



TOWER B - SECTION

GROUP HEAFEY

365 Forest Street, Ottawa, ON K2B 7Z7

1 : 200

1887-2303-19

B30

D07-12-20-0041

2021.10.26



Dessiné par : Tanya Nadeau
 Conçu par : Christian Rheault

53 blvd Saint-Raymond, Suite 200-A
 Gatineau, QC J8Y 1R8
 www.lrarch.ca



NOTES

- THESE NOTES APPLY TO ALL DRAWINGS.
- THE MECHANICAL DESIGN SHOWN IN THESE DRAWINGS IS BASED ON DATA TAKEN FROM EXP STORM WATER MANAGEMENT REPORT (SWM BELOW) AND COMPRISES SCHEDULE F OF THAT REPORT AND ALSO FROM EXP'S C100 DRAWING (EDITED FOR BREVITY).
- REFER TO EXP DRAWINGS FOR CIVIL DESIGN.
- ALL STORM PIPE LOCATIONS, PIPE INVERTS, CATCH BASIN AND AREA DRAIN LOCATIONS ARE TAKEN FROM THE SWM.
- "PST" AREA DESIGNATIONS ARE TAKEN FROM FIGURE A-2 OF THE SWM.
- DATA FOR CISTERN SIZING WAS TAKEN FROM TABLES IN APPENDIX D OF THE SWM.
- CISTERN 1 IS INTENDED TO SERVE THE "10mm" VOLUME IDENTIFIED IN THE SWM.
- CISTERN 2 IS INTENDED TO SERVE ALL OTHER FLOWS IDENTIFIED IN THE SWM.
- THE OIL GRIT SEPARATOR (OGS, STORMCEPTOR MODEL EFD4) FLOW RATE AND AREA SERVED WAS DETERMINED FROM THE SWM. CHAMBER WILL BE FACTORY FABRICATED AND SIT ON THE P-1 SLAB WITH ACCESS IN THE LANDSCAPE ARE A ABOVE. IT SHALL MEET OR EXCEED ALL THE REQUIREMENTS OF THE SWM. SIZE SHOWN HERE IS NOMINAL 1500mm DIAMETER, 900mm SOLID ACCESS HATCH, SIDE INLET AND DISCHARGE.
- THE PUMP/FILTRATION SYSTEM DESIGNATED P-01 CAPACITY IS BASED ON PROVIDING WATER FOR IRRIGATION AND FOR HOSE BIBB AND NON-FREEZE WALL HYDRANT USE. THE SYSTEM IS BASED ON "CLEAN FLO WATER TECHNOLOGIES" UL FILTRATION STORMWATER PROCESS DESIGN AND YIELDS WATER SUITABLE FOR NON-POTABLE USE. ALL PIPING AND EQUIPMENT CONNECTED TO THIS SYSTEM SHALL BE IDENTIFIED AS NON-POTABLE THROUGHOUT THE PROJECT. THE SYSTEM MAY ALSO BE USED FOR SELECT TOILET/URINAL FLUSHING.
- THE TREATMENT SYSTEM IS COMPRISED OF THE FOLLOWING.
 - PACKAGED STORMWATER PUMPING AND TREATMENT SYSTEM. THE SYSTEM SHALL BE DESIGNED TO AUTOMATICALLY REUSE STORMWATER. THE STORMWATER SHALL BE TREATED AND USED FOR IRRIGATION, HOSE BIBBS, TOILET AND URINAL FLUSHING.
 - PACKAGED SYSTEM SHALL BE A COMPLETELY SKID MOUNTED SYSTEM AND INCLUDE EVERYTHING IN A SINGLE COHESIVE FINISHED PRODUCT.
 - PACKAGED SYSTEM SHALL CONTAIN ALL COMPONENTS NECESSARY TO PROCESS AND PRESSURIZE THE COLLECTED STORMWATER INCLUDING BUT NOT LIMITED TO:
 - STORAGE TANK ACCESSORIES
 - TRANSFER PUMP
 - FILTRATION
 - ULTRAFILTRATION MEMBRANE
 - DAY TANK
 - CHLORINE INJECTION RECIRCULATION (NON GASEOUS STORAGE)
 - REPRESSURIZATION BOOSTER PUMPS
 - BLADDER TANK
 - STORMWATER CONTROL AND MONITORING SYSTEM
 - CONNECTION TO BUILDING AUTOMATION SYSTEM (BAS) BACNET TCP/IP PROTOCOL.

THIS DRAWING, OR PARTS THEREOF, MAY NOT BE REPRODUCED OR USED IN ANY FORM, BY ANY METHOD, FOR ANY PURPOSE, WITHOUT THE WRITTEN PERMISSION OF QUADRANT ENGINEERING.

THIS DRAWING IS TO BE READ IN CONJUNCTION WITH THE SPECIFICATION. WHERE CONFLICT ARISES THE MORE STRINGENT OF THE TWO SHALL APPLY.

COPYRIGHT © 2021 QUADRANT ENGINEERING.

THE CONTRACT DOCUMENTS ARE THE PROPERTY OF QUADRANT ENGINEERING LIMITED (QE)

THE CONTRACTOR SHALL OBTAIN A FULL SET OF ALL CONSULTANTS' DESIGN DOCUMENTS PRIOR TO STARTING WORK.

QE BEARS NO RESPONSIBILITY FOR INTERPRETATIONS OF THESE DOCUMENTS BY OTHERS.

UPON WRITTEN APPLICATION QE WILL PROVIDE WRITTEN CLARIFICATION REGARDING THE INTENT OF THE CONTRACT DOCUMENTS.

QE REVIEW OF SHOP DRAWINGS SUBMITTED BY THE CONTRACTOR IS FOR DESIGN CONFORMANCE ONLY.

DRAWINGS ARE NOT TO BE SCALED FOR CONSTRUCTION. CONTRACTOR TO VERIFY ALL CONDITIONS AND DIMENSIONS, ON SITE, REQUIRED TO PERFORM THE WORK AND REPORT ANY DISCREPANCIES WITH THE CONTRACT DOCUMENTS TO THE DESIGN TEAM BEFORE COMMENCING WORK.

LEGEND

ST	STORM DRAIN ABOVE GRADE/FLOOR
ST -	STORM DRAIN BURIED
---	NON-POTABLE WATER
---	PIPE DROPS, PIPE RISERS
+	DIELECTRIC UNION
⊕	PUMP, PIPE SIZE IS NOT CONNECTION SIZE.
⊕	COMBO SHUTOFF AND BALANCING VALVE
⊕	ISOLATING VALVE
⊕	PRESSURE REDUCING VALVE
⊕	STRAINER
⊕	CHECK VALVE

DRAWING LIST

M-005	SITE PLAN TOWERS A AND B
M-006	CISTERN SCHEMATICS AND DETAILS
M-140	LEVEL P-2 MECHANICAL SWM DESIGN
M-150	LEVEL P-1 MECHANICAL SWM DESIGN

NO.	REVISION	DATE
8	ISSUED FOR SITE PLAN APPROVAL	09 DEC 2021
7	ISSUED FOR CONSULTANT COORDINATION	08 DEC 2021
6	ISSUED FOR SITE PLAN COORDINATION	26 NOV 2021
5	ISSUED FOR SITE PLAN COORDINATION	12 NOV 2021
4	ISSUED FOR COORDINATION (ONLY M-290)	26 MAY 2021
3	ISSUED FOR COORDINATION (ONLY M-005)	23 FEB 2021
2	ISSUED FOR COORDINATION	29 JAN 2021
1	ISSUED FOR DESIGN BRIEF	21 DEC 2020

365 FOREST ST
TOWER A AND B

QUADRANT
an Installectric Company
2283 ST LAURENT BLVD. UNIT 203, OTTAWA, ONTARIO, K1G 5A2
TEL. (613) 567-1487 FAX. (613) 567-1493
E-Mail: mail@quadrantengineering.ca

CURRENT DATE	Thu, 09 Dec 2021, 14:53
SCALE	1:250
DRAWN	AR/CWC
DESIGNED	AR/CWC
CHECKED	CWC
PROJECT	20-Q086
DRAWING NUMBER	M-005

SITE PLAN
TOWERS A AND B

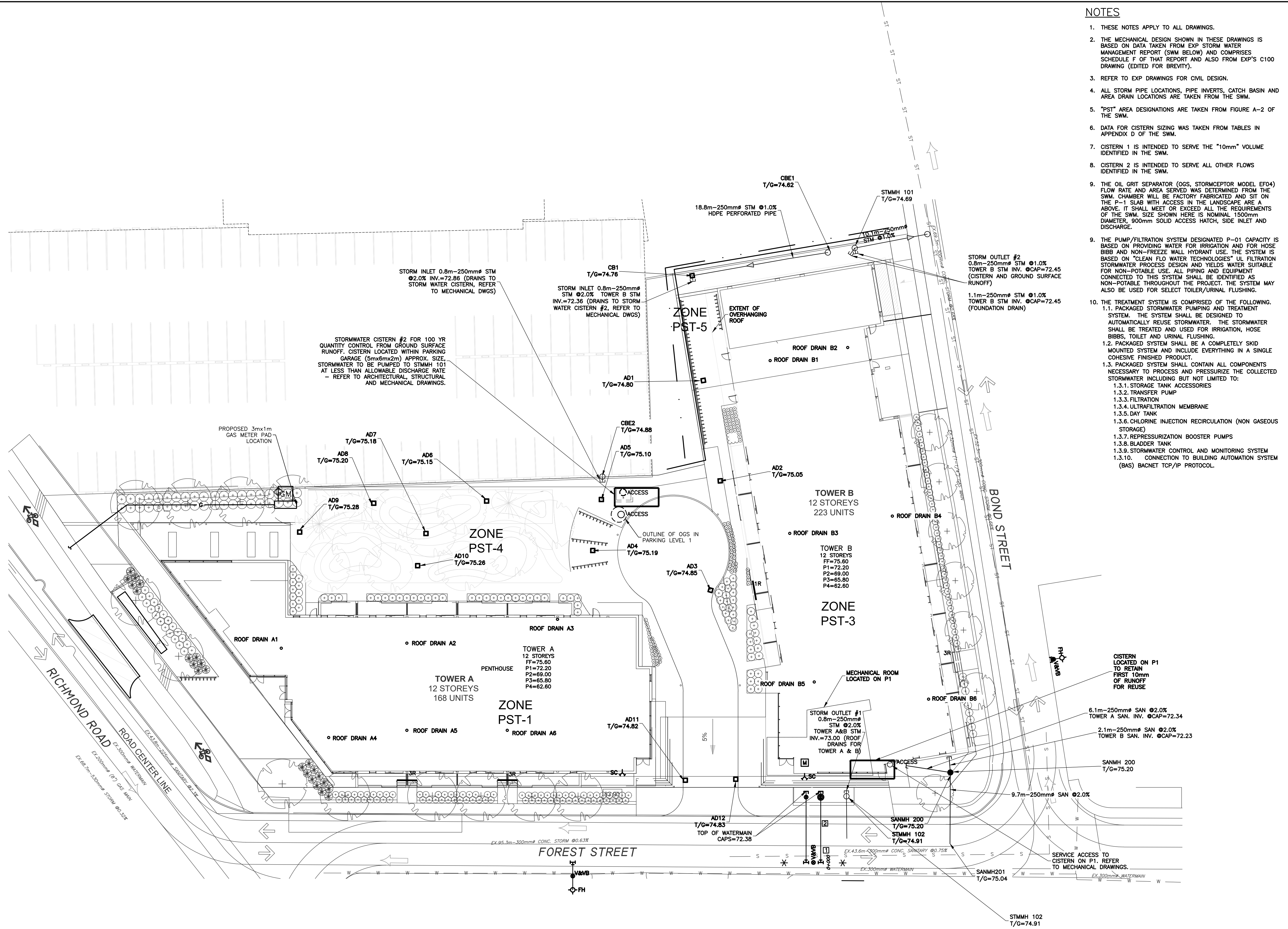

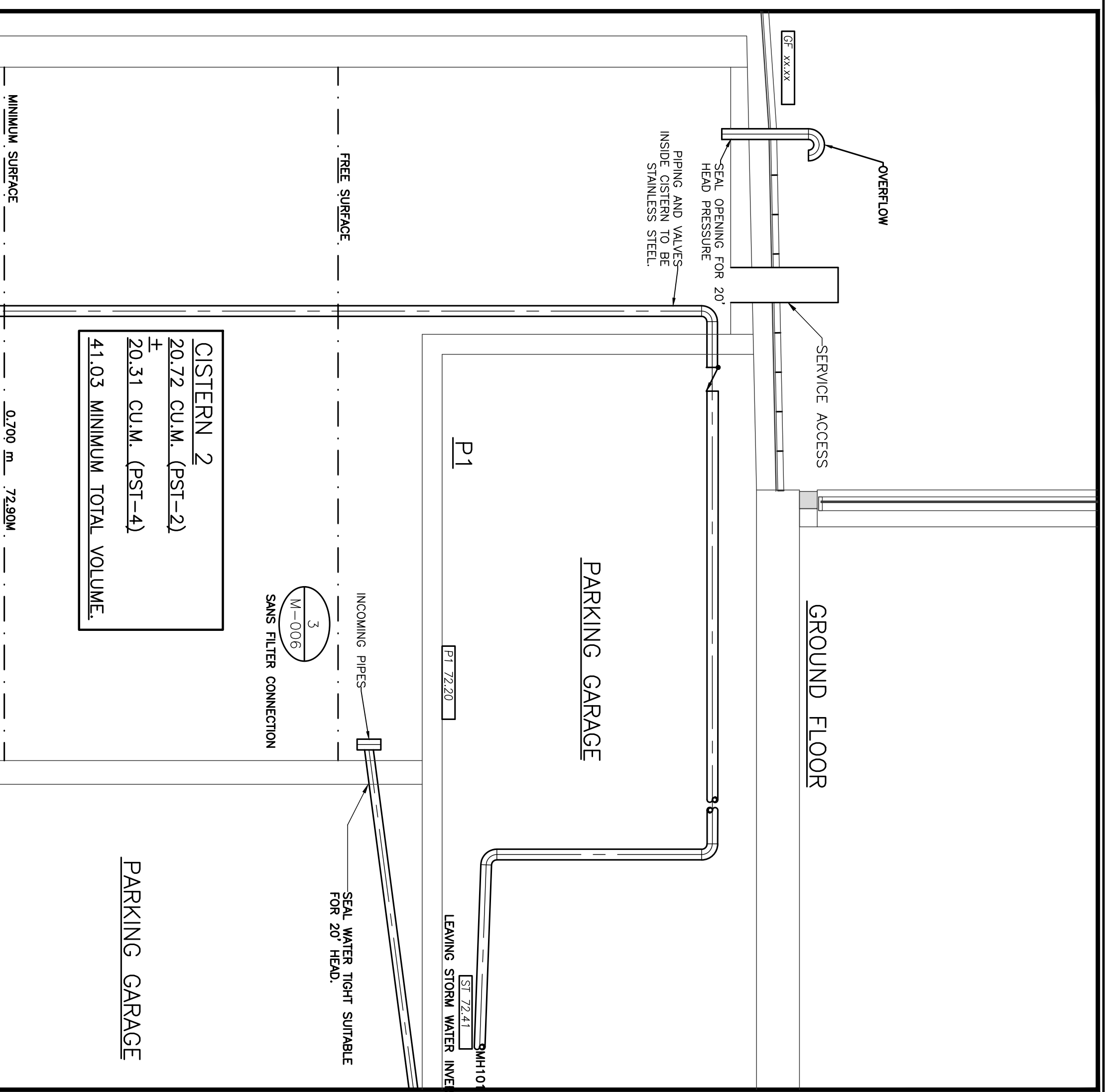
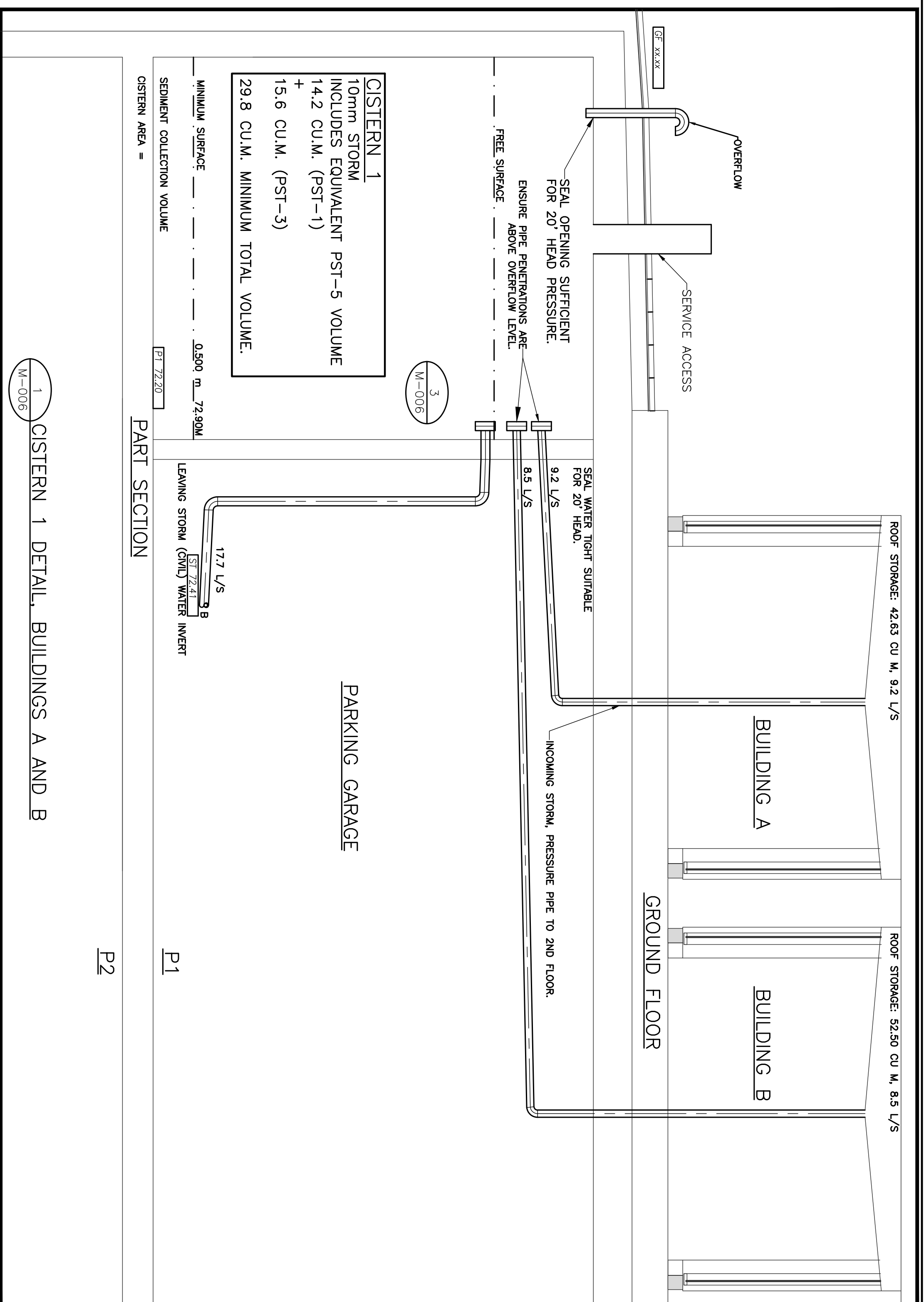

CISTERN AND OIL/GREASE SEPARATOR (OGS) SCHEDULE

TAG	SWM REPORT FIGURE/TABLE	CATCHMENT	RELEASE RATE L/S	STORAGE CUBIC METER	10mm STORAGE CUBIC METER	TO LEAVING STORM	TO CISTERN
GIS-01	A-2/D-12-D-13	PST-1 + PST-2	92.2-8.5	42.63-52.50	29.8	GRAVITY	N/A
GIS-02	A-2/D-14	PST-4	16.5	41.03	0	PUMPED	N/A
OGS	A-2/D-11	DRIVEWAY	39.6	N/A	N/A	N/A	CS-02

REFERENCE: SITE SERVICING AND STORM/WATER MANAGEMENT REPORT 365 FOREST STREET, OTTAWA ON AS PREPARED BY EXP

NOTES
1. SEE NOTES ON M-005

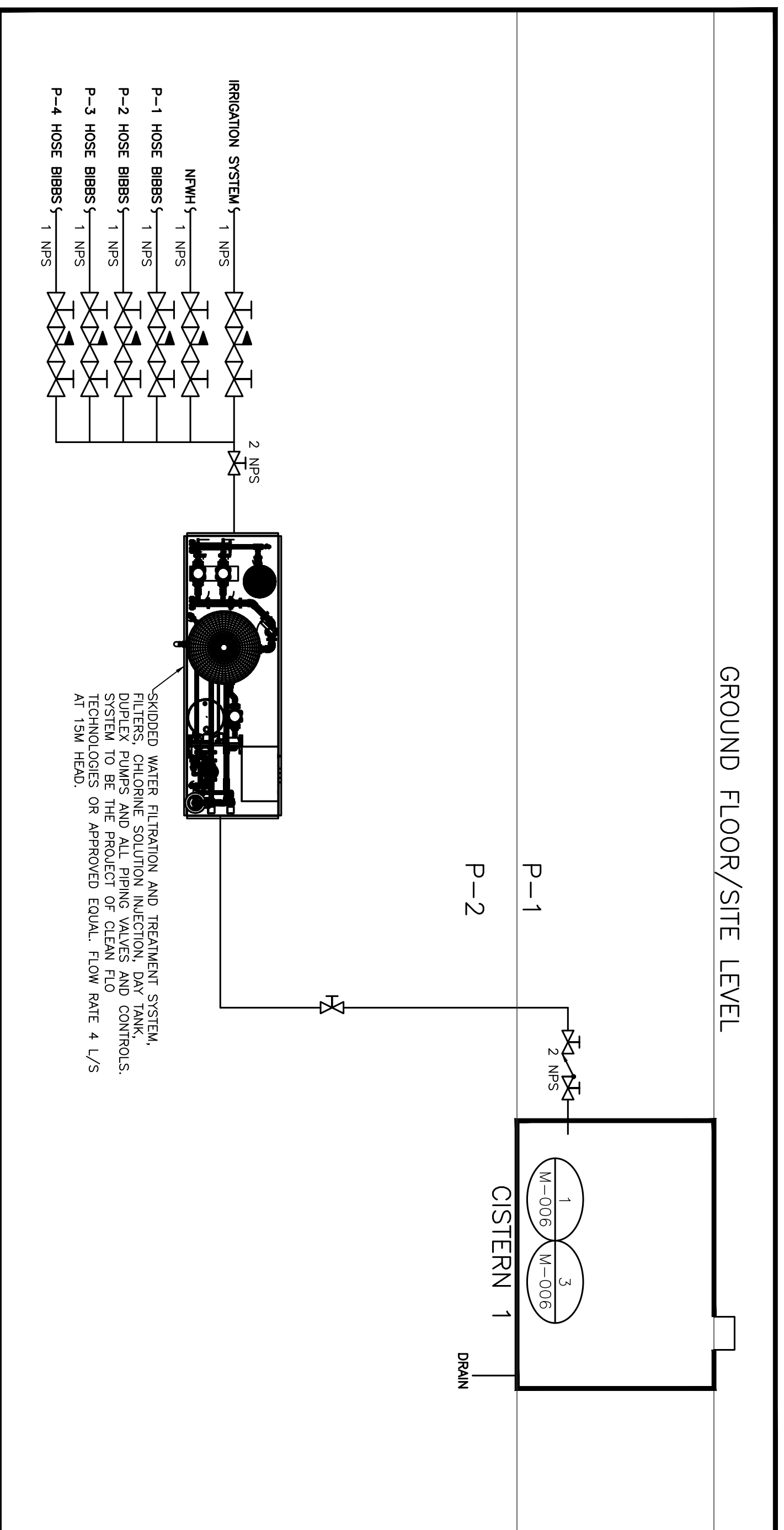
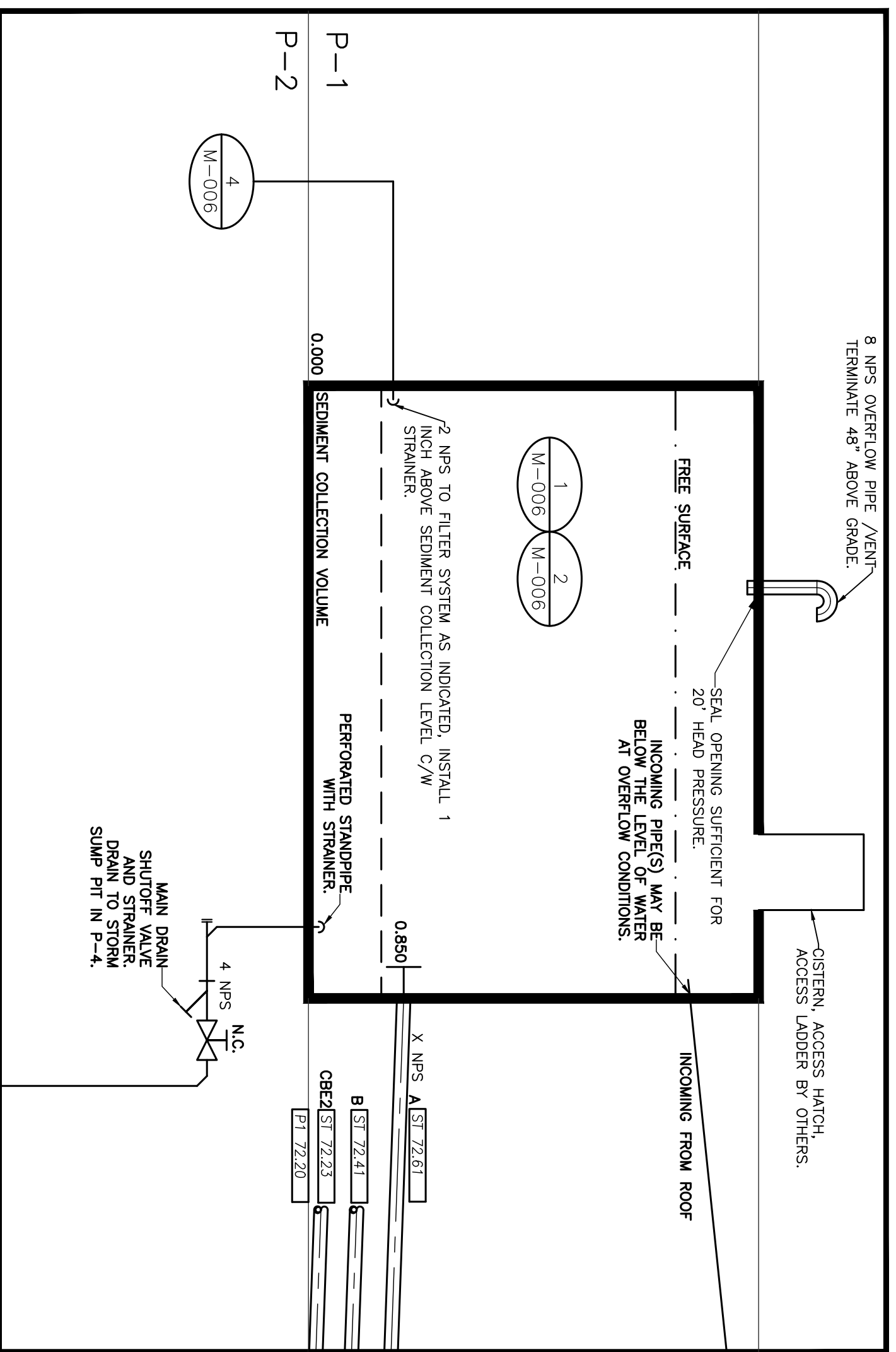

CISTERN NOTES

1. SEE EXP SERVICES INC. STORMWATER MANAGEMENT REPORT FOR THE DESIGN OF THE CISTERN AND OGS. THE SYSTEM THAT REPORT SHALL FORM PART OF THE SUPPORTING DOCUMENTS FOR THIS CONTRACT. THE CONTRACTOR SHALL READ THE REPORT PRIOR TO STARTING CONTRACT WORK.
2. THIS CONTRACTOR TO PROVIDE PIPING, CONTROLS, AND ELECTRICAL CONNECTIONS TO THE CISTERN. CISTERN TO BE PROVIDED BY GENERAL CONTRACTOR. PRESSURE AND WATER TIGHT.
3. ALL PIPING SHALL BE PRESSURE PIPING INCLUDING STAIN UP TO THE 2ND FLOOR.
4. ALL PIPING TO BE IDENTIFIED AS "NON-PORTABLE WATER" IN ADDITION TO ANY DEMONSTRATION REQUIRED IN THE SPECIFICATION.
5. ALL PENETRATIONS OF THE CISTERN SHALL BE MADE PRESSURE AND WATER TIGHT.
6. THIS CONTRACTOR TO MEASURE AREA OF CISTERN AFTER IT IS FORMED AND DETERMINE HEIGHTS OF ALL PIPING AND ELECTRICAL CONNECTIONS TO ENGINEER FOR REVIEW PRIOR TO STARTING WORK. ALL PIPE AND CONTROLS OPENINGS TO BE COURED IN THE CISTERN AFTER IT IS FORMED.

3 CISTERN STORM WATER MANAGEMENT SYSTEM, GENERAL CISTERN SCHEMATIC 1

4 CISTERN STORM WATER MANAGEMENT SYSTEM, CISTERN WATER TREATMENT SCHEMATIC

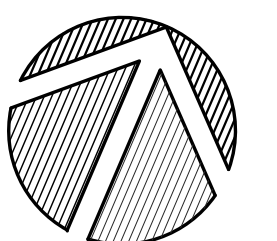

365 FOREST ST
TOWER A AND B

QUADRANT
ENGINEERING INC.

2263 ST LAURENT BLVD, UNIT 203, OTTAWA, ONTARIO, K1G 5K2
TEL: (613) 567-1487 FAX: (613) 567-1493
E-Mail: mail@quadrantengineering.co

COMMENT DATE: 09 DEC 2021, 14:53
SCALE: NTS
DRAWN: AR/CWC
DESIGNED: AR/CWC
CHECKED: CMC
PROJECT: 20-0086
DRAWING NUMBER: M-006

NO.	REVISION	DATE
8	ISSUED FOR SITE PLAN APPROVAL	09 DEC 2021
7	ISSUED FOR CONSULTANT COORDINATION	08 DEC 2021
6	ISSUED FOR SITE PLAN COORDINATION	26 NOV 2021
5	ISSUED FOR SITE PLAN COORDINATION	12 NOV 2021
4	ISSUED FOR COORDINATION (ONLY M-290)	26 MAY 2021
3	ISSUED FOR COORDINATION (ONLY M-095)	23 FEB 2021
2	ISSUED FOR COORDINATION	29 JAN 2021
1	ISSUED FOR DESIGN BRIEF	21 DEC 2020

THIS DRAWING OR PART THEREOF MAY NOT BE REPRODUCED, COPIED, STORED IN A RETRIEVAL SYSTEM, OR TRANSMITTED IN ANY FORM OR BY ANY METHOD, FOR ANY PURPOSE, WITHOUT THE WRITTEN PERMISSION OF QUADRANT ENGINEERING.

THIS DRAWING IS TO BE READ IN CONJUNCTION WITH THE SPECIFICATION, WHERE CONFLICT ARISES THE MORE STRINGENT OF THE TWO SHALL APPLY.

COPYRIGHT © 2021 QUADRANT ENGINEERING.

THE CONTRACT DOCUMENTS ARE THE PROPERTY OF QUADRANT ENGINEERING LIMITED (QEL)

THE CONTRACTOR SHALL OBTAIN A FULL SET OF ALL THE CONSULTANT'S DESIGN DOCUMENTS PRIOR TO STARTING WORK. HE BEARS NO RESPONSIBILITY FOR INTERPRETATIONS OF THESE DOCUMENTS BY OTHERS.

UPON WRITTEN APPLICATION QEL WILL PROVIDE WRITTEN CLARIFICATION REGARDING THE INTENT OF THE CONTRACT DOCUMENTS.

NO REVIEW OF SHOP DRAWINGS SUBMITTED BY THE CONTRACTOR IS FOR DESIGN CONFORMANCE ONLY.

DRAWINGS ARE NOT TO BE SEALED FOR CONSTRUCTION UNLESS ON SITE. REQUIRED TO PERFORM THE WORK AND REPORT ANY DISCREPANCIES WITH THE CONTRACT DOCUMENTS TO THE DESIGN TEAM BEFORE COMMENCING WORK.

20Q086

NOTES

1. SEE NOTES ON M-005

THIS DRAWING, OR PARTS THEREOF, MAY NOT BE REPRODUCED OR USED IN ANY FORM, BY ANY METHOD, FOR ANY PURPOSE, WITHOUT THE WRITTEN PERMISSION OF QUADRANT ENGINEERING.

THIS DRAWING IS TO BE READ IN CONJUNCTION WITH THE SPECIFICATION. WHERE CONFLICT ARISES THE MORE STRINGENT OF THE TWO SHALL APPLY.

COPYRIGHT © 2021 QUADRANT ENGINEERING.

THE CONTRACT DOCUMENTS ARE THE PROPERTY OF QUADRANT ENGINEERING LIMITED (QE)

THE CONTRACTOR SHALL OBTAIN A FULL SET OF ALL CONSULTANTS' DESIGN DOCUMENTS PRIOR TO STARTING WORK.

QE BEARS NO RESPONSIBILITY FOR INTERPRETATIONS OF THESE DOCUMENTS BY OTHERS.

UPON WRITTEN APPLICATION QEL WILL PROVIDE WRITTEN CLARIFICATION REGARDING THE INTENT OF THE CONTRACT DOCUMENTS.

QE REVIEW OF SHOP DRAWINGS SUBMITTED BY THE CONTRACTOR IS FOR DESIGN CONFORMANCE ONLY.

DRAWINGS ARE NOT TO BE SCALED FOR CONSTRUCTION. CONTRACTOR TO VERIFY ALL CONDITIONS AND DIMENSIONS, ON SITE, REQUIRED TO PERFORM THE WORK AND REPORT ANY DISCREPANCIES WITH THE CONTRACT DOCUMENTS TO THE DESIGN TEAM BEFORE COMMENCING WORK.

20Q086

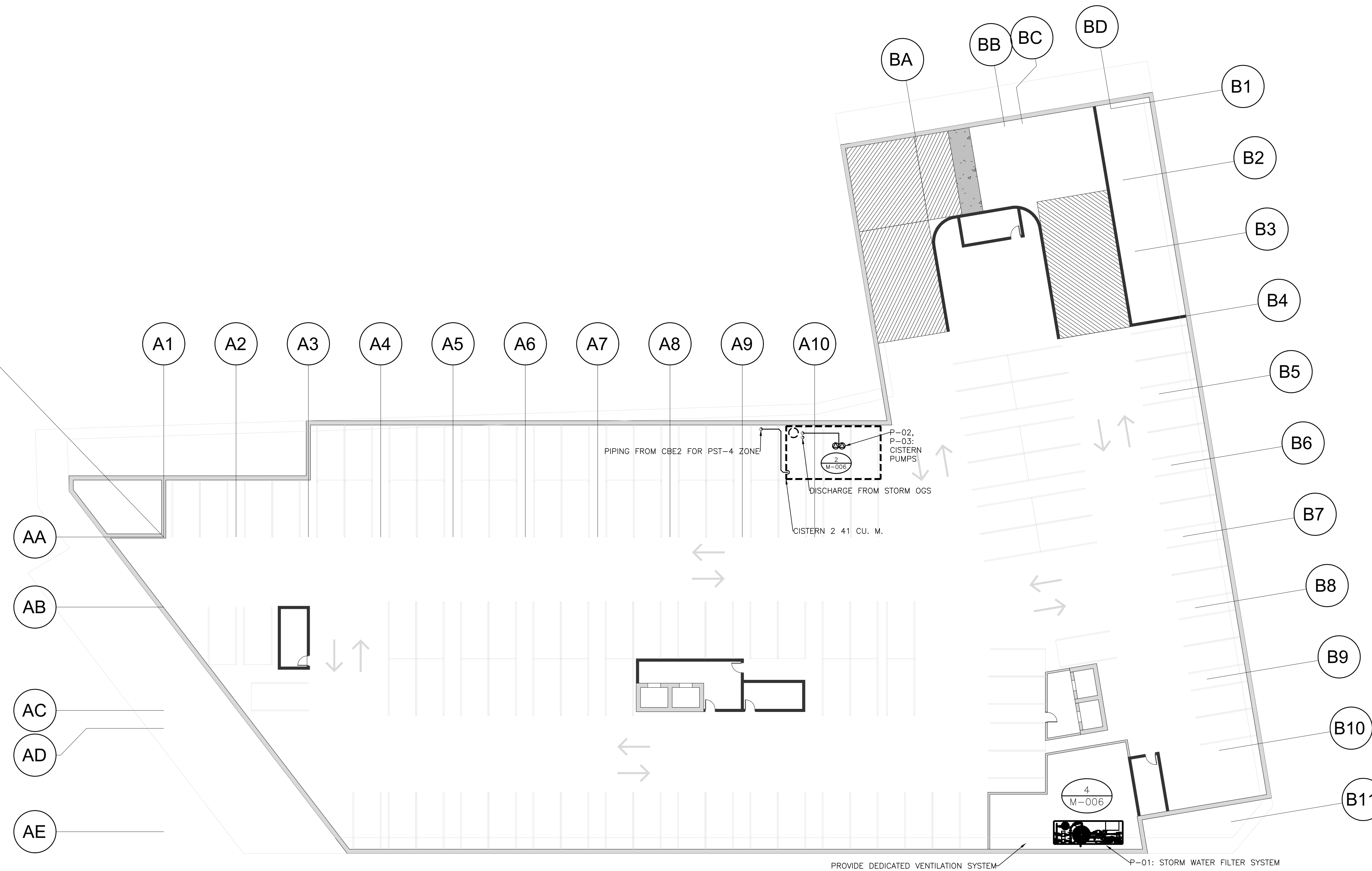

NO.	REVISION	DATE
8	ISSUED FOR SITE PLAN APPROVAL	09 DEC 2021
7	ISSUED FOR CONSULTANT COORDINATION	08 DEC 2021
6	ISSUED FOR SITE PLAN COORDINATION	26 NOV 2021
5	ISSUED FOR SITE PLAN COORDINATION	12 NOV 2021
4	ISSUED FOR COORDINATION (ONLY M-290)	26 MAY 2021
3	ISSUED FOR COORDINATION (ONLY M-005)	23 FEB 2021
2	ISSUED FOR COORDINATION	29 JAN 2021
1	ISSUED FOR DESIGN BRIEF	21 DEC 2020

365 FOREST ST
TOWER A AND B

QUADRANT
an Instalelectric Company

2283 ST LAURENT BLVD. UNIT 203, OTTAWA, ONTARIO, K1G 5A2
TEL. (613) 567-1487 FAX. (613) 567-1493
E-Mail: mail@quadrantengineering.ca

CURRENT DATE	Thu, 09 Dec 2021, 14:53
SCALE	1:250
DRAWN	AR/CWC
DESIGNED	AR/CWC
CHECKED	CWC
PROJECT	20-Q086
DRAWING NUMBER	

M-140

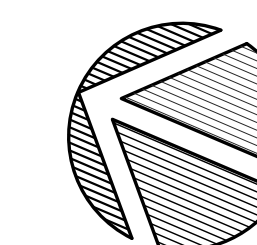

LEVEL P-2
MECHANICAL SWM DESIGN

NOTES

1. SEE NOTES ON M-005

THIS DRAWING, OR PARTS THEREOF, MAY NOT BE REPRODUCED OR USED IN ANY FORM, BY ANY METHOD, FOR ANY PURPOSE, WITHOUT THE WRITTEN PERMISSION OF QUADRANT ENGINEERING.

THIS DRAWING IS TO BE READ IN CONJUNCTION WITH THE SPECIFICATION. WHERE CONFLICT ARISES THE MORE STRINGENT OF THE TWO SHALL APPLY.

COPYRIGHT © 2021 QUADRANT ENGINEERING.

THE CONTRACT DOCUMENTS ARE THE PROPERTY OF QUADRANT ENGINEERING LIMITED (QE)

THE CONTRACTOR SHALL OBTAIN A FULL SET OF ALL CONSULTANTS' DESIGN DOCUMENTS PRIOR TO STARTING WORK.

QE BEARS NO RESPONSIBILITY FOR INTERPRETATIONS OF THESE DOCUMENTS BY OTHERS.

UPON WRITTEN APPLICATION QEL WILL PROVIDE WRITTEN CLARIFICATION REGARDING THE INTENT OF THE CONTRACT DOCUMENTS.

ON REVIEW OF SHOP DRAWINGS SUBMITTED BY THE CONTRACTOR IS FOR DESIGN CONFORMANCE ONLY.

DRAWINGS ARE NOT TO BE SCALED FOR CONSTRUCTION. CONTRACTOR TO VERIFY ALL CONDITIONS AND DIMENSIONS, ON SITE, REQUIRED TO PERFORM THE WORK AND REPORT ANY DISCREPANCIES WITH THE CONTRACT DOCUMENTS TO THE DESIGN TEAM BEFORE COMMENCING WORK.

20Q086

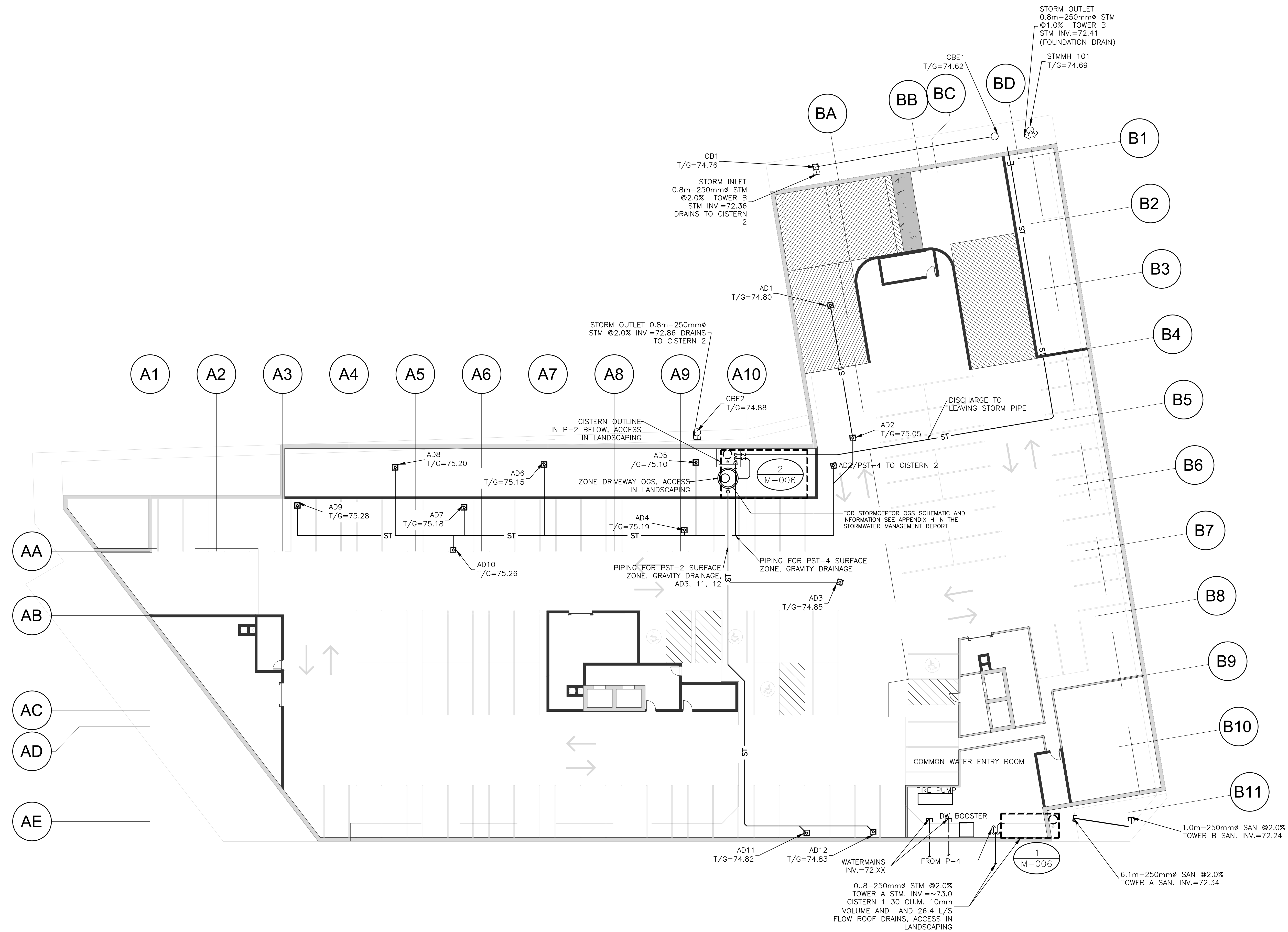

1 FLOOR PLAN
M-150

NO.	REVISION	DATE
8	ISSUED FOR SITE PLAN APPROVAL	09 DEC 2021
7	ISSUED FOR CONSULTANT COORDINATION	08 DEC 2021
6	ISSUED FOR SITE PLAN COORDINATION	26 NOV 2021
5	ISSUED FOR SITE PLAN COORDINATION	12 NOV 2021
4	ISSUED FOR COORDINATION (ONLY M-290)	26 MAY 2021
3	ISSUED FOR COORDINATION (ONLY M-005)	23 FEB 2021
2	ISSUED FOR COORDINATION	29 JAN 2021
1	ISSUED FOR DESIGN BRIEF	21 DEC 2020

365 FOREST ST
TOWER A AND B

QUADRANT
an Insalactic Company

2283 ST LAURENT BLVD. UNIT 203, OTTAWA, ONTARIO, K1G 5A2
TEL. (613) 567-1487 FAX. (613) 567-1493
E-Mail: mail@quadrantengineering.ca

CURRENT DATE	Thu, 09 Dec 2021, 14:53
SCALE	1:250
DRAWN	AR/CWC
DESIGNED	AR/CWC
CHECKED	CWC
PROJECT	20-Q086
DRAWING NUMBER	M-150

LEVEL P-1
MECHANICAL SWM DESIGN

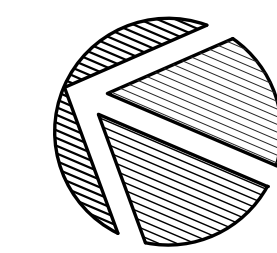

Stormceptor[®] EF Sizing Report

STORMCEPTOR[®] ESTIMATED NET ANNUAL SEDIMENT (TSS) LOAD REDUCTION

12/07/2021

Province:	Ontario
City:	Ottawa
Nearest Rainfall Station:	OTTAWA CDA RCS
Climate Station Id:	6105978
Years of Rainfall Data:	20

Project Name:	01
Project Number:	365
Designer Name:	C Clark
Designer Company:	quadrant engineering
Designer Email:	dhwboiler@gmail.com
Designer Phone:	613-406-5037
EOR Name:	
EOR Company:	
EOR Email:	
EOR Phone:	

Site Name:	365 Forest Street Ottawa
------------	--------------------------

Drainage Area (ha):	0.08
% Imperviousness:	1.00

Runoff Coefficient 'c': 1.00

Particle Size Distribution:	Fine
Target TSS Removal (%):	80.0

Required Water Quality Runoff Volume Capture (%):	90.00
Estimated Water Quality Flow Rate (L/s):	2.71
Oil / Fuel Spill Risk Site?	Yes
Upstream Flow Control?	No
Peak Conveyance (maximum) Flow Rate (L/s):	39.60
Site Sediment Transport Rate (kg/ha/yr):	

Net Annual Sediment (TSS) Load Reduction Sizing Summary	
Stormceptor Model	TSS Removal Provided (%)
EFO4	96
EFO6	99
EFO8	100
EFO10	100
EFO12	100

Recommended Stormceptor EFO Model: EFO4
Estimated Net Annual Sediment (TSS) Load Reduction (%): 96
Water Quality Runoff Volume Capture (%): > 90

Stormceptor® EF Sizing Report

THIRD-PARTY TESTING AND VERIFICATION

► **Stormceptor® EF and Stormceptor® EFO** are the latest evolutions in the Stormceptor® oil-grit separator (OGS) technology series, and are designed to remove a wide variety of pollutants from stormwater and snowmelt runoff. These technologies have been third-party tested in accordance with the Canadian ETV **Procedure for Laboratory Testing of Oil-Grit Separators** and performance has been third-party verified in accordance with the **ISO 14034 Environmental Technology Verification (ETV)** protocol.

PERFORMANCE

► **Stormceptor® EF and EFO** remove stormwater pollutants through gravity separation and floatation, and feature a patent-pending design that generates positive removal of total suspended solids (TSS) throughout each storm event, including high-intensity storms. Captured pollutants include sediment, free oils, and sediment-bound pollutants such as nutrients, heavy metals, and petroleum hydrocarbons. Stormceptor is sized to remove a high level of TSS from the frequent rainfall events that contribute the vast majority of annual runoff volume and pollutant load. The technology incorporates an internal bypass to convey excessive stormwater flows from high-intensity storms through the device without resuspension and washout (scour) of previously captured pollutants. Proper routine maintenance ensures high pollutant removal performance and protection of downstream waterways.

PARTICLE SIZE DISTRIBUTION (PSD)

► The **Canadian ETV PSD** shown in the table below was used, or in part, for this sizing. This is the identical PSD that is referenced in the Canadian ETV **Procedure for Laboratory Testing of Oil-Grit Separators** for both sediment removal testing and scour testing. The Canadian ETV PSD contains a wide range of particle sizes in the sand and silt fractions, and is considered reasonably representative of the particle size fractions found in typical urban stormwater runoff.

Particle Size (µm)	Percent Less Than	Particle Size Fraction (µm)	Percent
1000	100	500-1000	5
500	95	250-500	5
250	90	150-250	15
150	75	100-150	15
100	60	75-100	10
75	50	50-75	5
50	45	20-50	10
20	35	8-20	15
8	20	5-8	10
5	10	2-5	5
2	5	<2	5

Stormceptor[®] EF Sizing Report

Rainfall Intensity (mm / hr)	Percent Rainfall Volume (%)	Cumulative Rainfall Volume (%)	Flow Rate (L/s)	Flow Rate (L/min)	Surface Loading Rate (L/min/m ²)	Removal Efficiency (%)	Incremental Removal (%)	Cumulative Removal (%)
1	22.3	22.3	0.22	13.0	11.0	100	22.3	22.3
2	17.8	40.0	0.44	27.0	22.0	100	17.8	40.0
3	13.1	53.1	0.67	40.0	33.0	100	13.1	53.1
4	9.2	62.4	0.89	53.0	44.0	100	9.2	62.4
5	6.5	68.9	1.11	67.0	56.0	98	6.4	68.8
6	5.1	74.0	1.33	80.0	67.0	96	4.9	73.6
7	3.4	77.3	1.56	93.0	78.0	94	3.1	76.8
8	3.0	80.3	1.78	107.0	89.0	91	2.7	79.5
9	3.6	84.0	2.00	120.0	100.0	89	3.2	82.8
10	2.5	86.5	2.22	133.0	111.0	88	2.2	85.0
11	1.7	88.2	2.45	147.0	122.0	87	1.5	86.5
12	1.4	89.6	2.67	160.0	133.0	85	1.2	87.7
13	1.9	91.5	2.89	173.0	145.0	84	1.6	89.3
14	1.3	92.8	3.11	187.0	156.0	83	1.1	90.4
15	1.3	94.1	3.34	200.0	167.0	82	1.0	91.4
16	0.8	94.9	3.56	214.0	178.0	81	0.6	92.1
17	0.8	95.7	3.78	227.0	189.0	78	0.6	92.7
18	0.4	96.1	4.00	240.0	200.0	77	0.3	93.0
19	0.5	96.6	4.23	254.0	211.0	77	0.3	93.4
20	0.2	96.8	4.45	267.0	222.0	76	0.2	93.5
21	0.5	97.3	4.67	280.0	234.0	76	0.4	93.9
22	0.3	97.6	4.89	294.0	245.0	75	0.2	94.1
23	1.1	98.7	5.12	307.0	256.0	75	0.8	95.0
24	0.3	99.0	5.34	320.0	267.0	75	0.2	95.2
25	0.0	99.0	5.56	334.0	278.0	74	0.0	95.2
30	1.0	100.0	6.67	400.0	334.0	72	0.7	95.9
35	0.0	100.0	7.78	467.0	389.0	69	0.0	95.9
40	0.0	100.0	8.90	534.0	445.0	67	0.0	95.9
45	0.0	100.0	10.01	600.0	500.0	64	0.0	95.9
50	0.0	100.0	11.12	667.0	556.0	62	0.0	95.9
Estimated Net Annual Sediment (TSS) Load Reduction =								96 %

Climate Station ID: 6105978 Years of Rainfall Data: 20



Stormceptor® EF Sizing Report

RAINFALL DATA FROM OTTAWA CDA RCS RAINFALL STATION

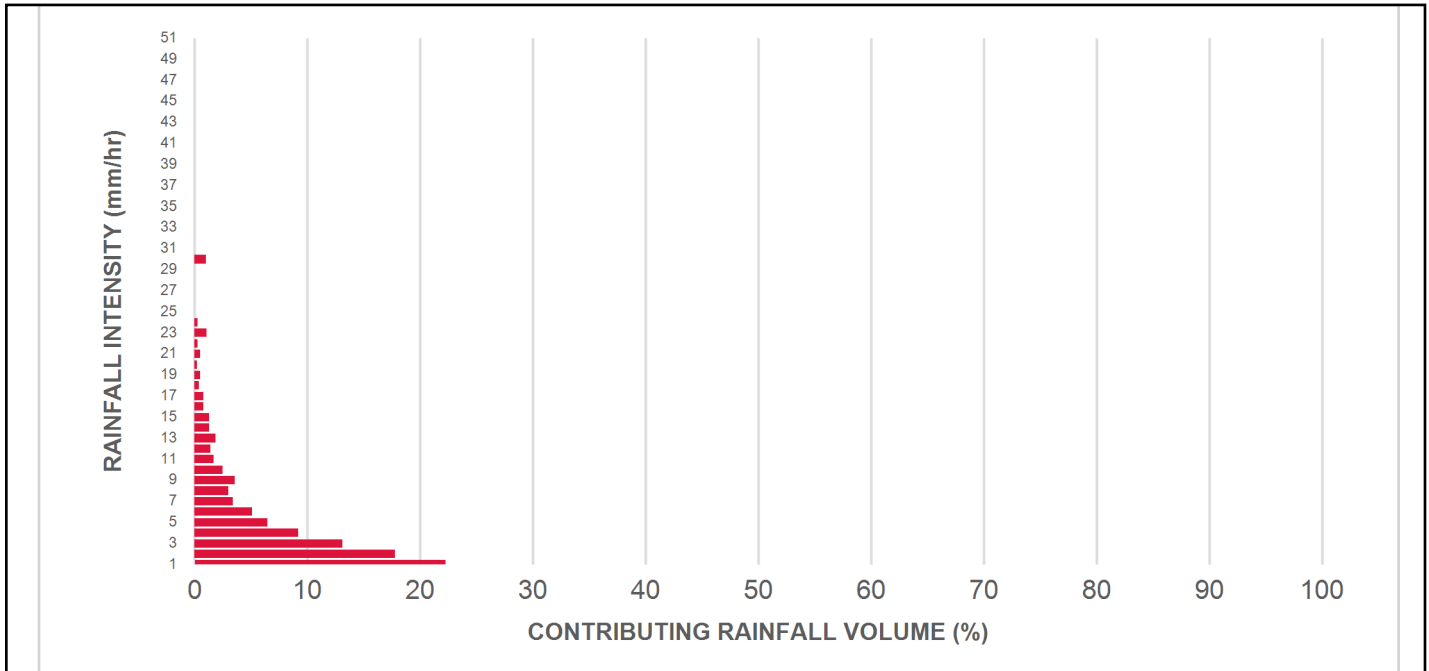

INCREMENTAL AND CUMULATIVE TSS REMOVAL FOR THE RECOMMENDED STORMCEPTOR® MODEL

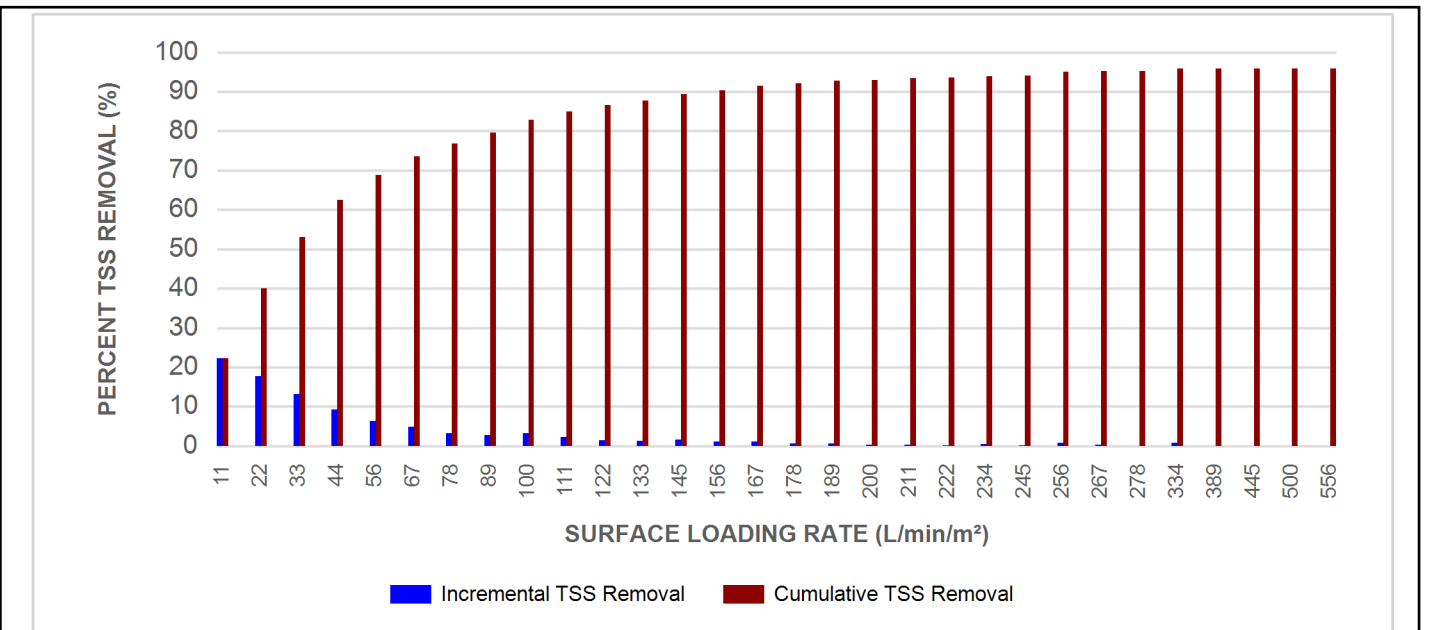

Stormceptor® EF Sizing Report

Maximum Pipe Diameter / Peak Conveyance

Stormceptor EF / EFO	Model Diameter		Min Angle Inlet / Outlet Pipes	Max Inlet Pipe Diameter		Max Outlet Pipe Diameter		Peak Conveyance Flow Rate	
	(m)	(ft)		(mm)	(in)	(mm)	(in)	(L/s)	(cfs)
EF4 / EFO4	1.2	4	90	609	24	609	24	425	15
EF6 / EFO6	1.8	6	90	914	36	914	36	990	35
EF8 / EFO8	2.4	8	90	1219	48	1219	48	1700	60
EF10 / EFO10	3.0	10	90	1828	72	1828	72	2830	100
EF12 / EFO12	3.6	12	90	1828	72	1828	72	2830	100

SCOUR PREVENTION AND ONLINE CONFIGURATION

► **Stormceptor® EF and EFO** feature an internal bypass and superior scour prevention technology that have been demonstrated in third-party testing according to the scour testing provisions of the Canadian ETV **Procedure for Laboratory Testing of Oil-Grit Separators**, and the exceptional scour test performance has been third-party verified in accordance with the ISO 14034 ETV protocol. As a result, Stormceptor EF and EFO are approved for online installation, eliminating the need for costly additional bypass structures, piping, and installation expense.

DESIGN FLEXIBILITY

► **Stormceptor® EF and EFO** offers design flexibility in one simplified platform, accepting stormwater flow from a single inlet pipe or multiple inlet pipes, and/or surface runoff through an inlet grate. The device can also serve as a junction structure, accommodate a 90-degree inlet-to-outlet bend angle, and can be modified to ensure performance in submerged conditions.

OIL CAPTURE AND RETENTION

► While Stormceptor® EF will capture and retain oil from dry weather spills and low intensity runoff, **Stormceptor® EFO** has demonstrated superior oil capture and greater than 99% oil retention in third-party testing according to the light liquid re-entrainment testing provisions of the Canadian ETV **Procedure for Laboratory Testing of Oil-Grit Separators**. Stormceptor EFO is recommended for sites where oil capture and retention is a requirement.

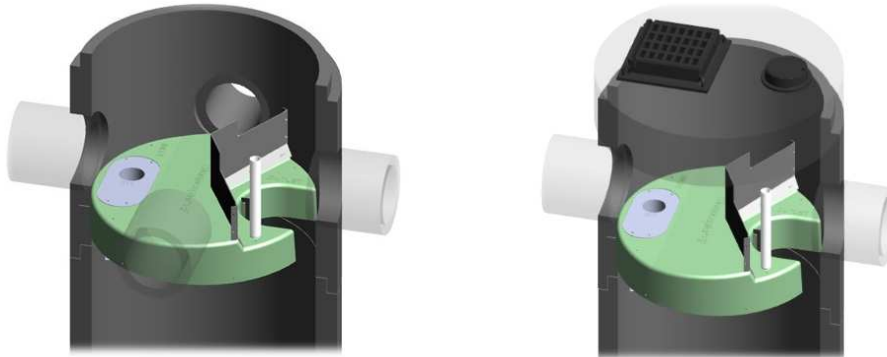

Stormceptor® EF Sizing Report

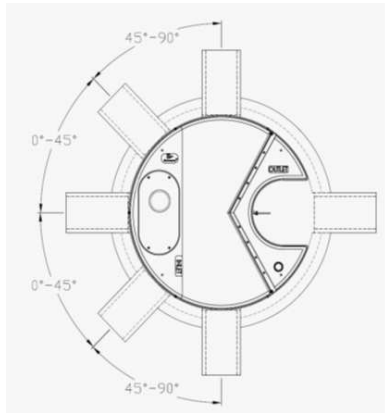

INLET-TO-OUTLET DROP

Elevation differential between inlet and outlet pipe inverts is dictated by the angle at which the inlet pipe(s) enters the unit.

0° - 45° : The inlet pipe is 1-inch (25mm) higher than the outlet pipe.

45° - 90° : The inlet pipe is 2-inches (50mm) higher than the outlet pipe.

HEAD LOSS

The head loss through Stormceptor EF is similar to that of a 60-degree bend structure. The applicable K value for calculating minor losses through the unit is 1.1.

For submerged conditions the applicable K value is 3.0.

Pollutant Capacity

Stormceptor EF / EFO	Model Diameter		Depth (Outlet Pipe Invert to Sump Floor)		Oil Volume		Recommended Sediment Maintenance Depth *		Maximum Sediment Volume *		Maximum Sediment Mass **	
	(m)	(ft)	(m)	(ft)	(L)	(Gal)	(mm)	(in)	(L)	(ft ³)	(kg)	(lb)
EF4 / EFO4	1.2	4	1.52	5.0	265	70	203	8	1190	42	1904	5250
EF6 / EFO6	1.8	6	1.93	6.3	610	160	305	12	3470	123	5552	15375
EF8 / EFO8	2.4	8	2.59	8.5	1070	280	610	24	8780	310	14048	38750
EF10 / EFO10	3.0	10	3.25	10.7	1670	440	610	24	17790	628	28464	78500
EF12 / EFO12	3.6	12	3.89	12.8	2475	655	610	24	31220	1103	49952	137875

*Increased sump depth may be added to increase sediment storage capacity

** Average density of wet packed sediment in sump = 1.6 kg/L (100 lb/ft³)

Feature	Benefit	Feature Appeals To
Patent-pending enhanced flow treatment and scour prevention technology	Superior, verified third-party performance	Regulator, Specifying & Design Engineer
Third-party verified light liquid capture and retention for EFO version	Proven performance for fuel/oil hotspot locations	Regulator, Specifying & Design Engineer, Site Owner
Functions as bend, junction or inlet structure	Design flexibility	Specifying & Design Engineer
Minimal drop between inlet and outlet	Site installation ease	Contractor
Large diameter outlet riser for inspection and maintenance	Easy maintenance access from grade	Maintenance Contractor & Site Owner

STANDARD STORMCEPTOR EF/EFO DRAWINGS

For standard details, please visit <http://www.imbriumsystems.com/stormwater-treatment-solutions/stormceptor-ef>

STANDARD STORMCEPTOR EF/EFO SPECIFICATION

For specifications, please visit <http://www.imbriumsystems.com/stormwater-treatment-solutions/stormceptor-ef>

Stormceptor[®] EF Sizing Report

STANDARD PERFORMANCE SPECIFICATION FOR “OIL GRIT SEPARATOR” (OGS) STORMWATER QUALITY TREATMENT DEVICE

PART 1 – GENERAL

1.1 WORK INCLUDED

This section specifies requirements for selecting, sizing, and designing an underground Oil Grit Separator (OGS) device for stormwater quality treatment, with third-party testing results and a Statement of Verification in accordance with ISO 14034 Environmental Management – Environmental Technology Verification (ETV).

1.2 REFERENCE STANDARDS & PROCEDURES

ISO 14034:2016 Environmental management – Environmental technology verification (ETV)

Canadian Environmental Technology Verification (ETV) Program’s **Procedure for Laboratory Testing of Oil-Grit Separators**

1.3 SUBMITTALS

1.3.1 All submittals, including sizing reports & shop drawings, shall be submitted upon request with each order to the contractor then forwarded to the Engineer of Record for review and acceptance. Shop drawings shall detail all OGS components, elevations, and sequence of construction.

1.3.2 Alternative devices shall have features identical to or greater than the specified device, including: treatment chamber diameter, treatment chamber wet volume, sediment storage volume, and oil storage volume.

1.3.3 Unless directed otherwise by the Engineer of Record, OGS stormwater quality treatment product substitutions or alternatives submitted within ten days prior to project bid shall not be accepted. All alternatives or substitutions submitted shall be signed and sealed by a local registered Professional Engineer, based on the exact same criteria detailed in Section 3, in entirety, subject to review and approval by the Engineer of Record.

PART 2 – PRODUCTS

2.1 OGS POLLUTANT STORAGE

The OGS device shall include a sump for sediment storage, and a protected volume for the capture and storage of petroleum hydrocarbons and buoyant gross pollutants. The minimum sediment & petroleum hydrocarbon storage capacity shall be as follows:

2.1.1	4 ft (1219 mm) Diameter OGS Units:	1.19 m ³ sediment / 265 L oil
	6 ft (1829 mm) Diameter OGS Units:	3.48 m ³ sediment / 609 L oil
	8 ft (2438 mm) Diameter OGS Units:	8.78 m ³ sediment / 1,071 L oil
	10 ft (3048 mm) Diameter OGS Units:	17.78 m ³ sediment / 1,673 L oil
	12 ft (3657 mm) Diameter OGS Units:	31.23 m ³ sediment / 2,476 L oil

PART 3 – PERFORMANCE & DESIGN

3.1 GENERAL

The OGS stormwater quality treatment device shall be verified in accordance with ISO 14034:2016 Environmental management – Environmental technology verification (ETV). The OGS stormwater quality treatment device shall



Stormceptor[®] EF Sizing Report

remove oil, sediment and gross pollutants from stormwater runoff during frequent wet weather events, and retain these pollutants during less frequent high flow wet weather events below the insert within the OGS for later removal during maintenance. The Manufacturer shall have at least ten (10) years of local experience, history and success in engineering design, manufacturing and production and supply of OGS stormwater quality treatment device systems, acceptable to the Engineer of Record.

3.2 SIZING METHODOLOGY

The OGS device shall be engineered, designed and sized to provide stormwater quality treatment based on treating a minimum of 90 percent of the average annual runoff volume and a minimum removal of an annual average 60% of the sediment (TSS) load based on the Particle Size Distribution (PSD) specified in the sizing report for the specified device. Sizing shall be determined using historical rainfall data and a sediment removal performance curve derived from the actual third-party verified laboratory testing data. The OGS device shall also have sufficient annual sediment storage capacity as specified and calculated in Section 2.1.

3.3 CANADIAN ETV or ISO 14034 ETV VERIFICATION OF SCOUR TESTING

The OGS device shall have Canadian ETV or ISO 14034 ETV Verification of third-party scour testing conducted in accordance with the Canadian ETV Program's **Procedure for Laboratory Testing of Oil-Grit Separators**.

3.3.1 To be acceptable for on-line installation, the OGS device must demonstrate an average scour test effluent concentration less than 10 mg/L at each surface loading rate tested, up to and including 2600 L/min/m².

3.4 LIGHT LIQUID RE-ENTRAINMENT SIMULATION TESTING

The OGS device shall have Canadian ETV or ISO 14034 ETV Verification of completed third-party Light Liquid Re-entrainment Simulation Testing in accordance with the Canadian ETV **Program's Procedure for Laboratory Testing of Oil-Grit Separators**, with results reported within the Canadian ETV or ISO 14034 ETV verification. This re-entrainment testing is conducted with the device pre-loaded with low density polyethylene (LDPE) plastic beads as a surrogate for light liquids such as oil and fuel. Testing is conducted on the same OGS unit tested for sediment removal to assess whether light liquids captured after a spill are effectively retained at high flow rates.

3.4.1 For an OGS device to be an acceptable stormwater treatment device on a site where vehicular traffic occurs and the potential for an oil or fuel spill exists, the OGS device must have reported verified performance results of greater than 99% cumulative retention of LDPE plastic beads for the five specified surface loading rates (ranging 200 L/min/m² to 2600 L/min/m²) in accordance with the Light Liquid Re-entrainment Simulation Testing within the Canadian ETV Program's **Procedure for Laboratory Testing of Oil-Grit Separators**. However, an OGS device shall not be allowed if the Light Liquid Re-entrainment Simulation Testing was performed with screening components within the OGS device that are effective at retaining the LDPE plastic beads, but would not be expected to retain light liquids such as oil and fuel.

Stormceptor[®] **EF**

Technical Manual

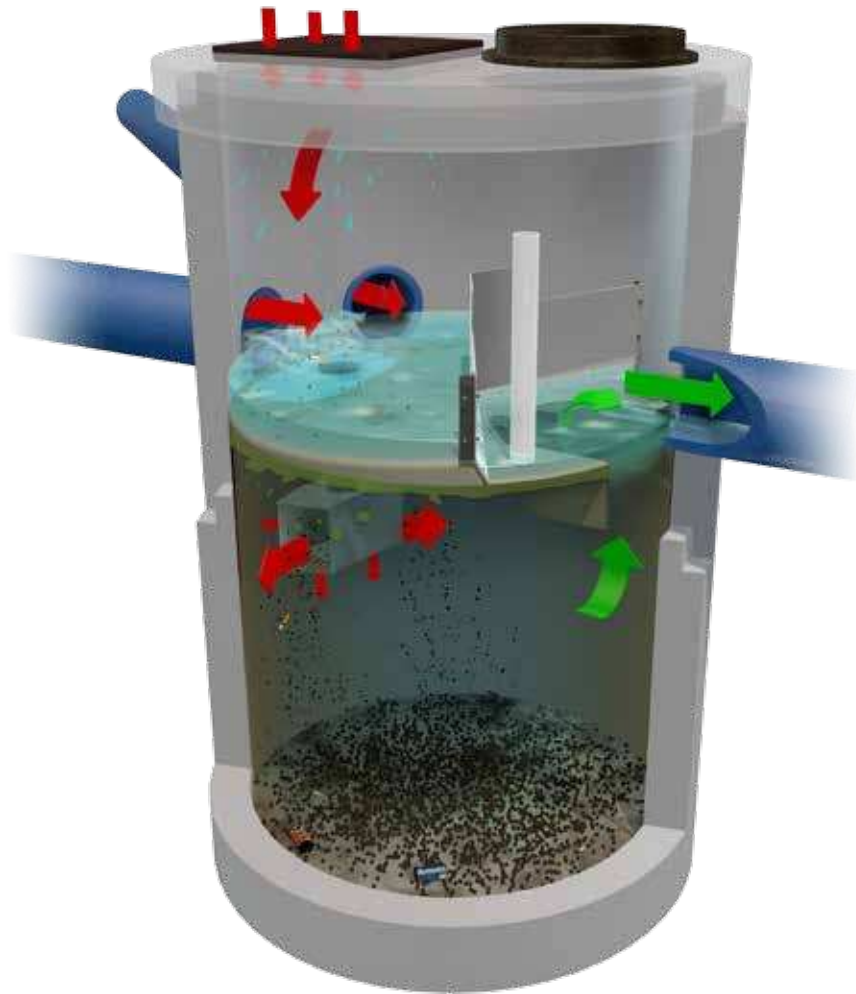

OVERVIEW

Stormceptor® EF is a continuation and evolution of the most globally recognized oil-grit separator (OGS) stormwater treatment technology - **Stormceptor®**. Also known as a hydrodynamic separator, the enhanced flow Stormceptor EF is a high performing oil-grit separator that effectively removes a wide variety of pollutants from stormwater and snowmelt runoff at higher flow rates as compared to the original Stormceptor. Stormceptor EF captures and retains sediment (TSS), free oils, gross pollutants and other pollutants that attach to particles, such as nutrients and metals. Stormceptor EF's patent-pending treatment and scour prevention technology and internal bypass ensures sediment is retained during all rainfall events..

Stormceptor EF offers design flexibility in one simplified platform, accepting stormwater flow from a single inlet pipe, multiple inlet pipes, and/or from the surface through an inlet grate. Stormceptor EF can also serve as a junction structure, accommodate a 90-degree inlet to outlet bend angle, and be modified to ensure performance in submerged conditions. With its scour prevention technology and internal bypass, Stormceptor EF can be installed online, eliminating the need for costly additional bypass structures.

OPERATION

- Stormwater enters the Stormceptor upper chamber through the inlet pipe(s) or a surface inlet grate. A specially designed insert reduces the influent velocity by creating a pond upstream of the insert's weir. Sediment particles immediately begin to settle. Swirling flow sweeps water, sediment, and floatables across the sloped surface of the insert to the inlet opening of the drop pipe, where a strong vortex draws water, sediment, oil, and debris down the drop pipe cone.
- Influent exits the cone into the drop pipe duct. The duct has two large rectangular outlet openings as well as perforations in the backside and floor of the duct. Influent is diffused through these various opening in multiple directions and at low velocity into the lower chamber.
- Free oils and other floatables rise up and are trapped beneath the insert, while sediment settles to the sump. Pollutants are retained for later removal during maintenance cleaning.
- Treated effluent enters the outlet riser, moves upward, and discharges to the top side of the insert downstream of the weir, where it flows out the outlet pipe.
- During intense storm events with very high influent flow rates, the pond height on the upstream side of the weir may exceed the height of the weir, and the excess flow passes over the top of the weir to the downstream side of the insert, and exits through the outlet pipe. This internal bypass feature allows for online installation, avoiding the cost of additional bypass structures. During bypass, the pond separates sediment from all incoming flows, while full treatment in the lower chamber continues at the maximum flow rate.
- Stormceptor EF's patent-pending enhanced flow and scour prevention technology ensures pollutants are captured and retained, allowing excess flows to bypass during infrequent, high intensity storms.
- **Refer to components identified in Figures 1 and 2 to understand the Stormceptor EF operation.**

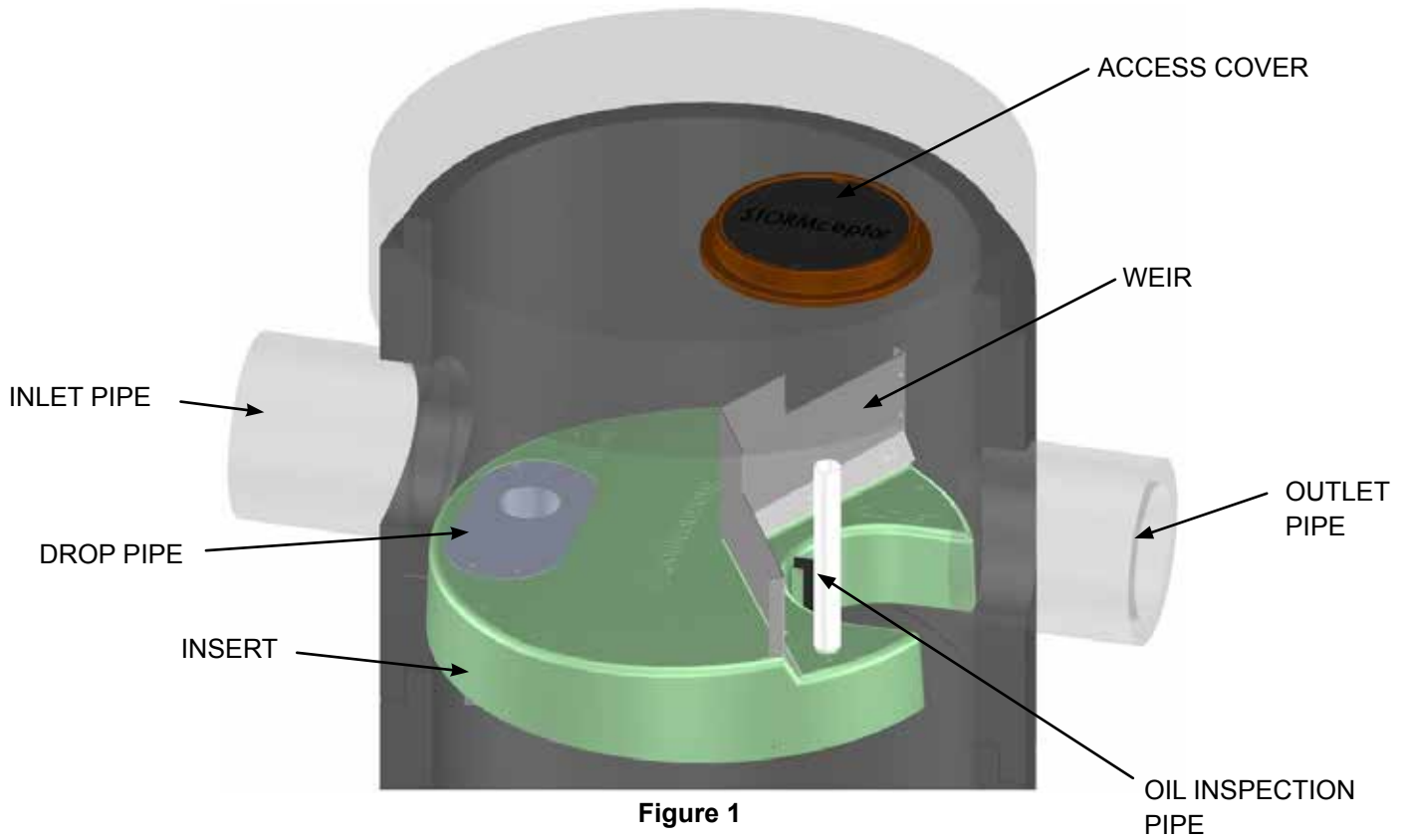

Figure 1

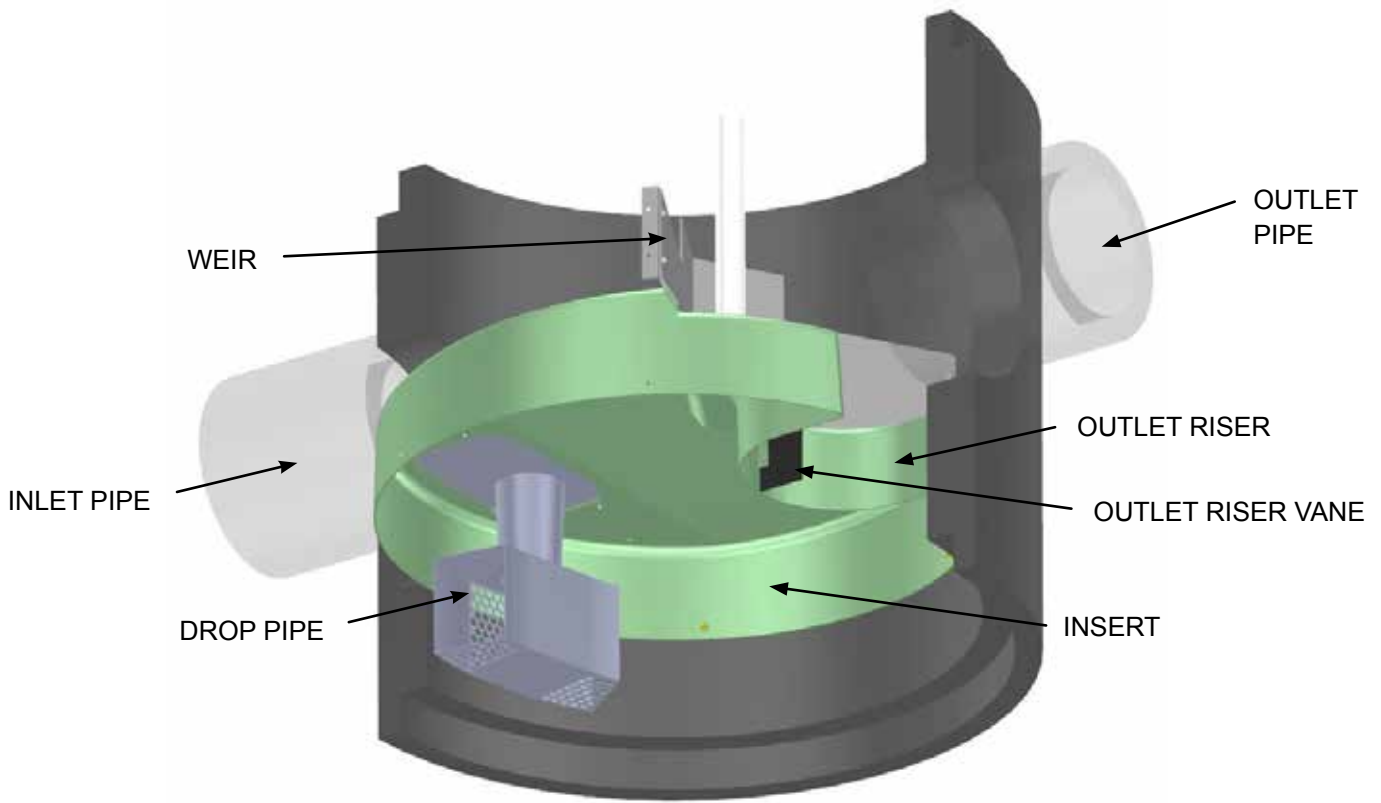

Figure 2

FEATURES AND BENEFITS

FEATURE	BENEFITS
Patent-pending enhanced flow, TSS treatment technology	Superior, verified third-party performance
Scour prevention with an internal bypass	Validated online installation and cost savings
Third-party verified light liquid capture (oil) and retention (Stormceptor EFO)	Proven performance for fuel/oil hotspot locations
Functions as bend, junction or inlet structure	Cost savings & design flexibility
Minimal drop between inlet and outlet	Site installation ease
Large diameter outlet riser for inspection and maintenance	Easy maintenance access from grade

APPLICATIONS

Stormceptor EF is designed as an 'at source' solution for commercial and industrial sites, urban environments, and residential developments. Stormceptor EF is ideal for:

- Pretreatment of wet ponds, filters, infiltration systems, bioretention, and other Low Impact Development (LID) applications
- Commercial sites
- Manufacturing/Industrial sites
- Residential developments
- Fueling stations, convenience stores, fast food restaurants
- Roads and highways
- Airports, seaports, and military bases
- Hydrocarbon spill, high pollutant load hotspots (Stormceptor EFO)

PRODUCT DETAILS

METRIC DIMENSIONS AND CAPACITIES								
Stormceptor Model	Inside Diameter	Minimum Surface to Outlet Invert Depth	Depth Below Outlet Pipe Invert	Wet Volume	Sediment Capacity ¹	Hydrocarbon Storage Capacity ²	Maximum Flow Rate into Lower Chamber ³	Peak Conveyance Flow Rate ⁴
	(m)	(mm)	(mm)	(L)	(m ³)	(L)	(L/s)	(L/s)
EF4 / EFO4	1.22	915	1524	1780	1.19	265	22.1 / 10.4	425
EF6 / EFO6	1.83	915	1930	5070	3.47	610	49.6 / 23.4	990
EF8 / EFO8	2.44	1219	2591	12090	8.78	1070	88.3 / 41.6	1700
EF10 / EFO10	3.05	1219	3251	23700	17.79	1670	138 / 65	2830
EF12 / EFO12	3.66	1524	3886	40800	31.22	2475	198.7 / 93.7	2830

U.S. DIMENSIONS AND CAPACITIES								
Stormceptor Model	Inside Diameter	Minimum Surface to Outlet Invert Depth	Depth Below Outlet Pipe Invert	Wet Volume	Sediment Capacity ¹	Hydrocarbon Storage Capacity ²	Maximum Flow Rate into Lower Chamber ³	Peak Conveyance Flow Rate ⁴
	(ft)	(in)	(in)	(gal)	(ft ³)	(gal)	(cfs)	(cfs)
EF4 / EFO4	4	36	60	471	42	70	0.78 / 0.37	15
EF6 / EFO6	6	36	76	1339	123	160	1.75 / 0.83	35
EF8 / EFO8	8	48	102	3194	310	280	3.12 / 1.47	60
EF10 / EFO10	10	48	128	6261	628	440	4.87 / 2.30	100
EF12 / EFO12	12	60	153	10779	1103	655	7.02 / 3.31	100

1. Sediment Capacity is measured from the floor to the bottom of the drop pipe cone. Sediment Capacity can be increased to accommodate specific site designs and pollutant loads. Contact your local representative for assistance.
2. Hydrocarbon Storage Capacity is measured from the bottom of the outlet riser to the underside of the insert. Hydrocarbon Storage Capacity can be increased to accommodate specific site designs and pollutant loads. Contact your local representative for assistance.
3. EF Maximum Flow Rate into Lower Chamber is based on a maximum surface loading rate (SLR) into the lower chamber of 1135 L/min/m² (27.9 gpm/ft²). EFO Maximum Flow Rate into Lower Chamber is based on a maximum surface loading rate (SLR) into the lower chamber of 535 L/min/m² (13.1 gpm/ft²).
4. Peak Conveyance Flow Rate is limited by a maximum velocity of 1.5 m/s (5 fps).

UNIT DESIGN

Sizing Methodology

Stormceptor® EF and Stormceptor® EFO are sized using local historical rainfall data for the site of interest, specific site parameters, and a performance curve for TSS removal derived from third-party testing conducted in accordance with the Canadian Environmental Technology Verification (ETV) Program's ***Procedure for Laboratory Testing of Oil-Grit Separators***. Every Stormceptor unit is designed to achieve the specified target TSS removal, however, for sites where oil/fuel capture and retention is an additional specified water quality objective Stormceptor EFO is the proper selection. The sizing methodology includes various considerations, including:

- Site parameters
- Local historical rainfall data
- Capture of the Canadian ETV particle size distribution
- Requirements for oil/fuel capture and retention
- Performance results from third-party testing and verification

State, provincial, and local regulatory agencies and municipalities may have specific sizing and design criteria for stormwater treatment systems such as OGS devices. To ensure proper sizing and design, contact your local Stormceptor representative for sizing and design assistance or visit www.imbriumsystems.com for more information.

ONLINE APPLICATION

Stormceptor EF's internal bypass and patent-pending scour prevention technology has demonstrated very effective retention of pollutants in third-party testing and verification following the Canadian ETV's ***Procedure for Laboratory Testing of Oil-Grit Separators***. Sediment scour prevention demonstrated an effluent concentration of less than 10 mg/L for sediment particles ranging from 1 to 1,000 microns, even during peak influent flow rates associated with infrequent high intensity storm events. While Stormceptor EF will capture oil, only the Stormceptor EFO configuration has been third-party tested and verified to retain greater than 99% of captured oil.

Based on these verified performance attributes, the most efficient and widely accepted application of Stormceptor EF is an online configuration, which allows all upstream conveyance flows to enter and exit the unit. The online application eliminates the need for costly additional bypass structures, piping and installation expense.

FLOW ENTRANCE OPTIONS

Single Inlet Pipe – A common design which includes one inlet pipe and one outlet pipe. A 90-degree (maximum) bend is also accepted with this configuration. **Example seen in Figure 3.**

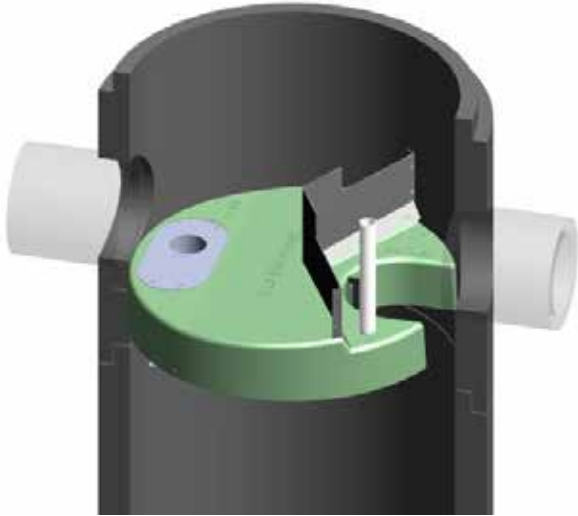

Figure 3

MAXIMUM PIPE DIAMETER		
MODEL	INLET	OUTLET
	(in / mm)	(in / mm)
EF4 / EFO4	24 / 610	24 / 610
EF6 / EFO6	36 / 915	36 / 915
EF8 / EFO8	48 / 1220	48 / 1220
EF10 / EFO10	72 / 1828	72 / 1828
EF12 / EFO12	72 / 1828	72 / 1828

Multiple Inlet Pipes – Allows for multiple inlet pipes of various diameters to enter the unit. **Example seen in Figure 4.**

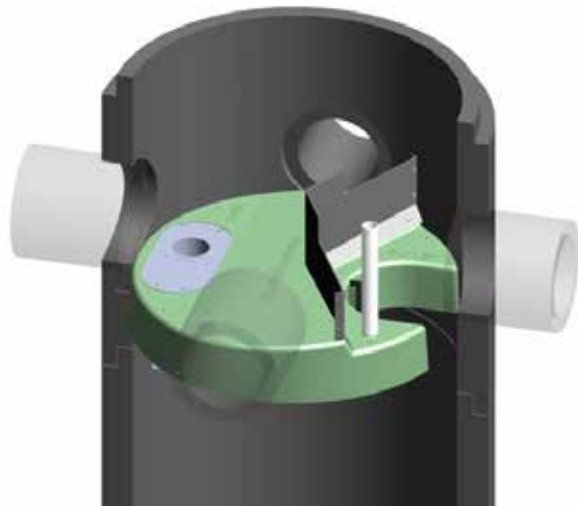

Figure 4

MAXIMUM PIPE DIAMETER		
MODEL	INLET	OUTLET
	(in / mm)	(in / mm)
EF4 / EFO4	18 / 457	24 / 610
EF6 / EFO6	30 / 762	36 / 915
EF8 / EFO8	42 / 1067	48 / 1220
EF10 / EFO10	60 / 1524	72 / 1828
EF12 / EFO12	60 / 1524	72 / 1828

Inlet Grate – Allows surface runoff to enter the unit from grade. The inlet grate option can also be used in conjunction with one inlet pipe or multiple inlet pipes. A removable flow deflector is added in the Stormceptor EF4/EFO4. **Example seen in Figure 5.**

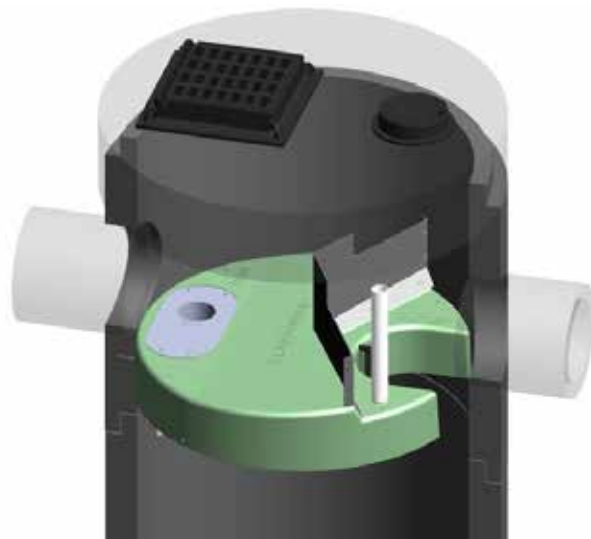

Figure 5

MAXIMUM PIPE DIAMETER		
MODEL	INLET	OUTLET
	(in / mm)	(in / mm)
EF4 / EFO4	24 / 610	24 / 610
EF6 / EFO6	36 / 915	36 / 915
EF8 / EFO8	48 / 1220	48 / 1220
EF10 / EFO10	72 / 1828	72 / 1828
EF12 / EFO12	72 / 1828	72 / 1828

INLET-TO-OUTLET DROP

Elevation differential between the inlet and outlet pipe inverts is dictated by the angle at which the inlet pipe(s) enters the unit (**illustration seen in Figure 6**).

0° – 45°: The inlet pipe is 1-inch (25mm) higher than the outlet pipe.

45° – 90°: The inlet pipe is 2-inches (50mm) higher than the outlet pipe.

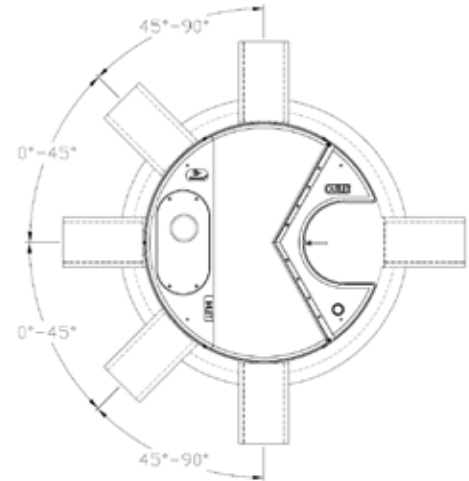

Figure 6

SUBMERGED (TAILWATER) DESIGN

Submerged or tailwater conditions are defined as standing water above the insert elevation during zero-runoff conditions. A weir height modification allows Stormceptor EF to operate under submerged conditions. The following information is necessary to properly design Stormceptor EF for the submerged condition:

- Stormceptor top of grade elevation
- Stormceptor outlet pipe invert elevation
- Standing water elevation

NOTE: The maximum weir height for Stormceptor EF is 48 inches (1200 mm). Contact your local Stormceptor representative for design assistance.

LIVE LOAD

Stormceptor EF is typically designed for local highway truck loading. In instances where other live loads are required, Stormceptor EF can be customized to meet the necessary structural requirements. Contact your local Stormceptor representative for design assistance.

SHALLOW COVER

Stormceptor EF is typically designed with a minimum depth of burial to the outlet invert based on the diameter of the inlet and outlet pipes. A common minimum burial depth to the outlet invert is 48 inches (1.2 meters). In instances where there may be site constraints to the depth of burial contact your local Stormceptor representative for design assistance.

HEAD LOSS

The head loss through Stormceptor EF is similar to that of a 60-degree bend structure. The applicable K value for calculating minor losses through the unit is 1.1. For submerged conditions the applicable K value is 3.0.

ABOVE-GROUND INSTALLATIONS

Stormceptor EF can be designed as a free-standing above-ground unit, constructed of fiberglass as illustrated in **Figure 7**. These customized units are lightweight and can be installed within a building footprint, providing structural support and installation advantages. Contact your local Stormceptor representative for design assistance.

PERFORMANCE VERIFICATION TESTING

Stormceptor EF has been third-party performance tested according to the Canadian Environmental Technical Verification (ETV) Procedure for **Laboratory Testing of Oil-Grit Separators**, and has received ISO 14034 Environmental Management – Environmental Technology Verification (ETV).

For more information, please visit www.imbriumsystems.com or contact your local Stormceptor representative.

INSTALLATION

For installation details, please visit www.imbriumsystems.com and refer to the Stormceptor EF Installation Guideline or contact your local Stormceptor representative.

INSPECTION AND MAINTENANCE

As with any stormwater treatment device, periodic inspection and maintenance of Stormceptor EF is required for long-term performance.

Inspection and maintenance is performed from grade without entering the unit. Sediment depth inspections are performed through the outlet riser, and oil presence can be determined through the oil inspection pipe. Oil presence and sediment depth are determined by inserting a Sludge Judge® or measuring stick to quantify the pollutant depths. Visual inspections of the insert can be performed to ensure there is no damage or blockages. A beneficial feature of Stormceptor EF in comparison to many other treatment practices is that once it is maintained, Stormceptor EF is functionally restored to its original condition.

When maintenance is required, a standard vacuum truck is used to remove the pollutants (sediment and floatables) from the lower chamber of the unit through the outlet riser. When an appreciable amount of oil or other hydrocarbons is present, these floatable pollutants can be removed by hydrovac from the water surface. Should an oil/fuel spill occur, or presence of oil/fuel be identified within the unit, it should be cleaned immediately by a licensed liquid waste hauler.

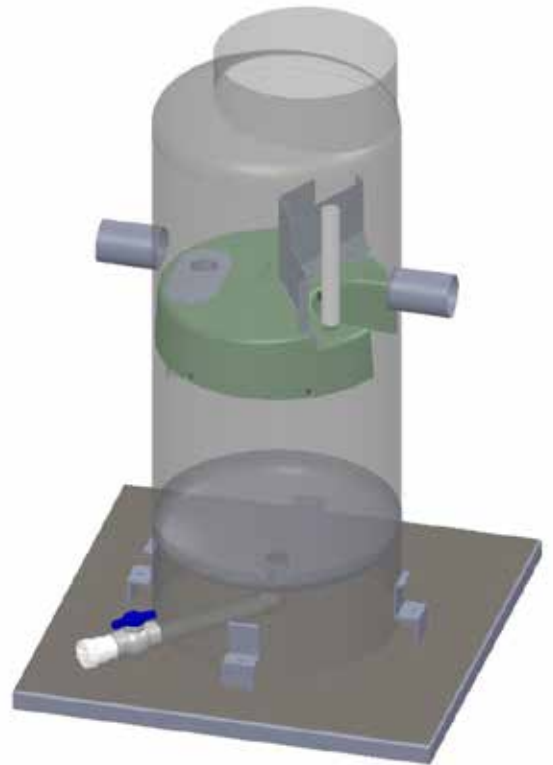

Figure 7

RECOMMENDED SEDIMENT DEPTHS FOR MAINTENANCE SERVICE*

MODEL	Sediment Depth
	(in/mm)
EF4 / EFO4	8 / 203
EF6 / EFO6	12 / 305
EF8 / EFO8	24 / 610
EF10 / EFO10	24 / 610
EF12 / EFO12	24 / 610

* Based on a minimum distance of 40 inches (1,016 mm) from bottom of outlet riser to top of sediment bed.

The frequency of inspection and maintenance may need to be adjusted based on site conditions to ensure the unit is operating and performing as intended. Maintenance costs will vary based on the size of the unit, site conditions, local requirements, location, and transportation distance(s).

For more details on inspection and maintenance refer to the Stormceptor EF Owner's Manual at www.imbriumsystems.com.

HYDROCARBON CAPTURE AND RETENTION

Stormceptor EFO

Stormceptor is often installed on high-traffic pollutant hotspots where hydrocarbon spill potential exists.

The technology platform of Stormceptor EFO is the same as Stormceptor EF, however the maximum surface loading rate into the lower chamber is restricted to a lower value with Stormceptor EFO, thereby ensuring excellent oil retention. Third-party testing in accordance with the Light Liquid Re-entrainment testing provisions within the Canadian ETV protocol *Procedure for Laboratory Testing of Oil-Grit Separators* demonstrated greater than 99% oil retention. Stormceptor EFO is engineered to capture and retain free floating oil/chemical/fuel spills, not emulsified hydrocarbons.

Oil Sheen

When oil is present in stormwater runoff, a sheen may be noticeable at the Stormceptor outlet. An oil rainbow or sheen can be noticeable at very low oil concentrations (< 10 mg/L). Despite the appearance of a sheen, Stormceptor EFO may still be functioning as intended.

Disposal

Maintenance providers are to follow all federal, state/provincial, and local requirements for disposal of hydrocarbons.

Oil Level Alarm

As an added safeguard, an oil level alarm is available as an optional feature for Stormceptor EFO. This is an electronic monitoring system designed to trigger a visual and audible alarm when a preset level of oil is captured in the lower chamber. The oil level alarm is installed as illustrated in **Figure 8**.

Optional Oil Alarm



OIL ALARM PROBE INSTALLED ON DOWNSTREAM SIDE OF WEIR

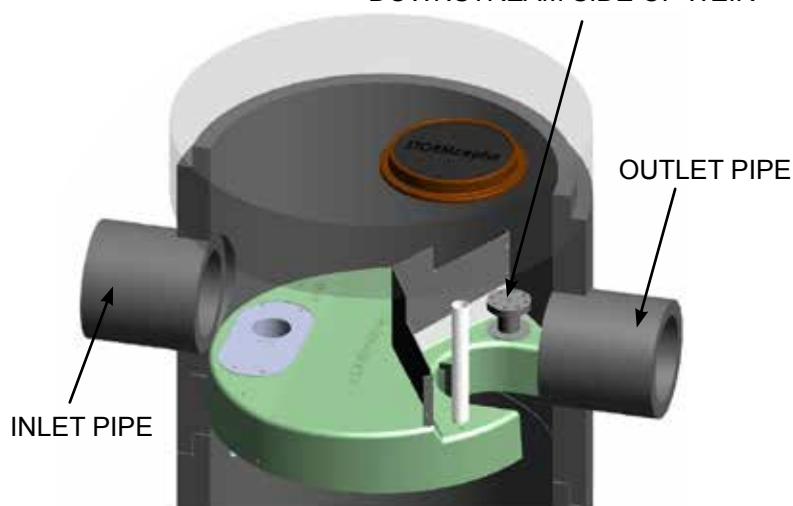

Figure 8

ADDITIONAL POLLUTANT STORAGE CAPACITY

Stormceptor EF/EFO can be easily modified to increase sediment storage capacity by extending the depth of the lower chamber. Stormceptor EFO can be modified to increase hydrocarbon storage capacity by extending the outlet riser, thereby providing the storage volumes depicted in the table below.

STORMCEPTOR EFO STORAGE VOLUME		
Stormceptor EFO Model	Standard Hydrocarbon Storage Capacity ¹	Extended Hydrocarbon Storage Capacity ^{1,2}
	(L / gal)	(L / gal)
EFO4	265 / 70	395 / 105
EFO6	610 / 160	1615 / 425
EFO8	1070 / 280	4340 / 1145
EFO10	1670 / 440	NA
EFO12	2475 / 655	NA

1. Hydrocarbon Storage Capacity is measured from the bottom of the outlet riser to the underside of the insert.
2. Distance from bottom of the extended outlet riser to top of the sediment maintenance depth is 914 mm (36 in).
NA –Not available in these model sizes

Additional hydrocarbon storage capacity can be added with a draw off tank.

Contact your local Stormceptor representative for additional information and design assistance.

HEALTH AND SAFETY

For all aspects of installation and inspection/maintenance, OSHA and appropriate local regulations should be followed to ensure safe practice.

Contact

888-279-8826 / 416-960-9900

info@imbriumsystems.com

www.imbriumsystems.com