



## Traffic Impact Assessment – Analysis

*11061917 Canada Inc.*

**Type of Document:**

Final Report

**Project Name:**

365 Forest Street

**Project Number:**

OTT-00252570-A0

**Submitted By:**

EXP Services Inc.

1595 Clark Boulevard

Brampton, ON L6T 4V1

t: +1.905.793.9800

**Date Submitted:**

May 20, 2021

# 11061917 Canada Inc.

## Traffic Impact Assessment – Analysis

**Type of Document:**

Final Report

**Project Name:**

365 Forest Street

**Project Number:**

OTT-00252570-A0

**Prepared By:**

EXP Services Inc.  
1595 Clark Boulevard  
Brampton, ON L6T 4V1



---

Yves-Marie Monereau, P.Eng, PE, PTOE, RSP.  
Manager, Traffic Engineering  
Transportation Planning



**Date Submitted:**

May 20, 2021



---

Jonathan Law, P.Eng.  
Transportation Engineer  
Transportation Planning

## Legal Notification

This report was prepared by EXP Services Inc. for the account of **11061917 Canada Inc.**

Any use which a third party makes of this report, or any reliance on or decisions to be made based on it, are the responsibility of such third parties. EXP Services Inc. accepts no responsibility for damages, if any, suffered by any third party as a result of decisions made or actions based on this project

## Table of Contents

	Page
<b>1 Screening Form .....</b>	<b>1</b>
<b>2 Scoping Report.....</b>	<b>1</b>
2.1 Proposed Development .....	1
2.2 Study Area.....	2
2.3 Time Periods .....	3
2.4 Horizon Years.....	3
2.5 Existing Conditions .....	4
2.5.1 Area Road Network.....	4
2.5.2 Existing Study Area Intersections.....	4
2.5.3 Existing Area Traffic Measures .....	6
2.5.4 Existing Driveways to Adjacent Developments.....	6
2.5.5 Pedestrian/Cycling Network .....	7
2.5.6 Transit Network.....	7
2.5.7 Existing Road Safety Conditions .....	10
2.6 Planned Conditions.....	11
2.6.1 Transportation Network Plans .....	11
2.6.2 Other Developments .....	11
2.7 Exemptions Review .....	11
<b>3 Forecasting.....</b>	<b>12</b>
3.1 Proposed Development .....	12
3.1.1 Mode Share .....	12
3.1.2 Development-Generated Travel Demand.....	13
3.1.3 Trip Distribution.....	13
3.1.4 Trip Assignment.....	13
3.2 Background Network Travel Demands.....	15
3.2.1 Transportation Network Plans .....	15
3.2.2 Background Traffic Growth.....	15
3.2.3 Other Developments .....	15

3.3	Demand Rationalization.....	15
3.3.1	Future (2024) Background Traffic.....	15
3.3.2	Future (2029) Background Traffic.....	17
<b>4</b>	<b>Analysis .....</b>	<b>20</b>
4.1	Development Design .....	20
4.2	Parking .....	20
4.3	Boundary Streets .....	20
4.4	Access Intersections.....	21
4.5	Transportation Demand Management.....	21
4.6	Neighbourhood Traffic Management.....	23
4.7	Transit .....	23
4.8	Network Concept .....	23
4.9	Network Intersections .....	23
4.9.1	Vehicular Level of Service.....	23
4.9.1.1	Future (2024) Total Traffic .....	23
4.9.1.2	Future (2029) Total Traffic .....	25
4.9.2	Multimodal Level of Service .....	27
4.9.3	Network Mitigation .....	28
<b>5</b>	<b>Conclusions and Recommendations .....</b>	<b>30</b>

## List of Appendices

- Appendix A – TIA Screening Form
- Appendix B – Site Plan
- Appendix C – Traffic and Collision Data
- Appendix D – Existing Traffic Level of Service Outputs
- Appendix E – Intersection Collision Diagrams
- Appendix F – Future Background Level of Service Outputs
- Appendix G – Future Total Traffic Level of Service Outputs
- Appendix H – Left Turn Lane Warrant Analysis
- Appendix I – Future Total & Mitigated Level of Service Outputs
- Appendix J – City of Ottawa TIA Credential Form

## List of Tables

	Page
Table 1 – Transit Stops .....	7
Table 2 – Existing Traffic Level of Service Analysis .....	10
Table 3 – Existing Travel Mode Proportions .....	12
Table 4 – Future Target Travel Mode Proportions .....	12
Table 5 – Trip Generation – Subject Site .....	13
Table 6 - Trip Distribution - Existing Traffic .....	13
Table 7 - Future (2024) Background Traffic Analysis .....	17
Table 8 - Future (2029) Background Traffic Analysis .....	19
Table 9 – Multimodal Level of Service .....	20
Table 10 - Reoccurring Collision Analysis .....	21
Table 11 - TDM Checklist .....	22
Table 12 - Future (2024) Total Traffic Analysis .....	25
Table 13 - Future (2029) Total Traffic Analysis .....	27
Table 14 – Intersection Multimodal Level of Service Analysis.....	27
Table 15 - Future (2029) Total Mitigated Traffic Analysis .....	29

## List of Figures

	Page
Figure 1 – Site Plan .....	1
Figure 2 – Proposed Study Area .....	3
Figure 3 - Existing Traffic Control and Lane Configuration .....	5
Figure 4 - Existing OC Transpo Area Network.....	8
Figure 5 – Existing Traffic Volumes.....	9
Figure 6 – Site Traffic – Subject Site.....	14
Figure 7 – Future (2024) Background Traffic Volumes.....	16
Figure 8 – Future (2029) Background Traffic Volumes.....	18
Figure 9 – Future (2024) Total Traffic Volumes .....	24
Figure 10 – Future (2029) Total Traffic Volumes .....	26

# 1 Screening Form

EXP completed a TIA screening form for the proposed development and submitted to City of Ottawa staff for review and confirmation of the need for completion of a Traffic Impact Assessment (TIA). A copy of the completed screening form is attached to this report as **Appendix A**.

The proposed development satisfies all three triggers (Trip Generation, Location and Safety) due to the size of the development, the development being located in a Design Priority Area (DPA) and Transit-Oriented Development (TOD) zone and the proximity of the proposed access to the existing signalized intersection of Alpine Drive and Carling Avenue. We have received confirmation to proceed with the Scoping Report (Step 2).

# 2 Scoping Report

## 2.1 Proposed Development

11061917 Canada Inc. is proposing a mixed-use development consisting of 391 residential units split between two buildings (Building A – 168 units, Building B – 223 units), up to 12 and stories high storeys high, located on 365 Forest Street between Bond Street and Richmond Road. The development will provide 431 parking spaces located in the proposed underground parking lot, accessible via Bond Street. A concept site plan is shown in **Figure 1** and is provided in full-size in **Appendix B**.

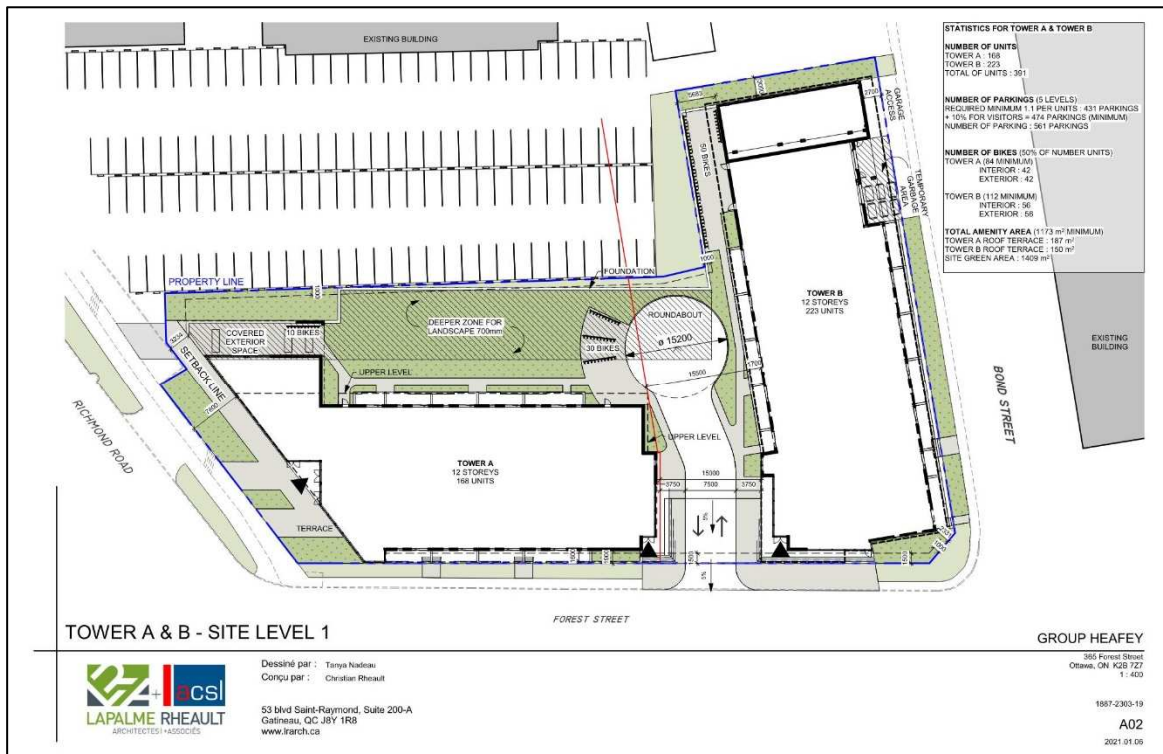

Figure 1 – Site Plan



The proposed development is located in a General Urban Area (Section 3.6.1 of the Official Plan) and spans multiple properties which are all located within Zone Arterial Mainstreet Subzone AM10:

- **1420 Richmond Road** is currently a gravel parking lot on the southeast corner of the Forest Street and Richmond Road intersection;
- **365 Forest Street** houses an automotive garage located in a 1-storey building on the property. The property also contains an asphalt parking lot; and
- **2583 Bond Street and 2589 Bond Street** are currently vacant and previously housed a used tire shop. An existing 1-storey building is located on the 2589 Bond Street property with exterior storage provided on the 2583 Bond Street property.

The Arterial Mainstreet zoning of the properties permits the proposed land use as per Part 10, Section 186 of the City of Ottawa Zoning Bylaw. The proposed development is to be phased with construction of one tower and the underground parking in Phase 1 and the second tower to follow in Phase 2.

The proposed development adheres to the Transit-Oriented Development goals in support of facilitating transit use. Direct pedestrian access is proposed to the existing Richmond Road sidewalk via the proposed sidewalk area. Pedestrian access is provided to Forest Street and Bond Street via proposed sidewalk surrounding the exterior of both buildings however due to the lack of existing sidewalk and walkways on Forest Street and Bond Street, pedestrian traffic will be primarily directed to Richmond Road.

Vehicular access to the proposed development will be provided from the proposed entrance on Forest Street located approximately 70m south of the intersection with Richmond Road.

## 2.2 Study Area

The proposed study area is as outlined and highlighted in **Figure 2**:

- Carling Avenue and Alpine Street Intersection;
- Richmond Road and Croydon Avenue Intersection;
- Carling Avenue and Croydon Avenue Intersection;
- Carling Avenue and Richmond Road Intersection;
- Richmond Road and Poulin Avenue Intersection and;
- All boundary roads to the proposed development (Carling Avenue, Richmond Road, Croydon Avenue, Forest Street and Bond Street).



## 2.5 Existing Conditions

### 2.5.1 Area Road Network

**Carling Avenue** is an east-west, City-owned, arterial roadway which extends from March Road to the west to Bronson Avenue to the east. It provides access from Highway 49 in Kanata to the Glebe south of Highway 417. Within the study area, Carling Avenue is a six-lane divided cross-section with auxiliary turning lanes at major intersections. West-bound traffic occupies the northern lanes and east-bound traffic occupies the southern lanes. The posted speed limit is 60km/hr.

**Richmond Road** is an east-west, City-owned, arterial roadway which extends from Baseline Road in the west (where it continues as Robertson Road) to Island Park Drive in the east (where it continues as Wellington Street West). Within the study area, Richmond Road has a two-lane undivided cross-section with a bike lane and parking permitted on the north side of the roadway and a separate bike lane provided adjacent to the sidewalk on the north side of the roadway. Auxiliary turn lanes are provided at major intersections. The posted speed limit is 50km/hr.

**Croydon Avenue** is a north-south, City-owned local roadway which extends between Carling Avenue to the south and Regina Street to the north. Within the study area, Croydon Avenue is a two-lane, undivided cross-section with no parking permitted on either side of the roadway. The posted speed limit is 40km/hr.

**Forest Street** is a north-south, City-owned, local roadway which extends between Carling Avenue to the south and Richmond Road to the north. Forest Street is a two-lane undivided cross-section with parking permitted on both sides of the roadway. The roadway intersects with Richmond Road and Carling Avenue at unsignalized intersections. The posted speed limit is 50km/hr.

**Bond Street** is an east-west, City-owned, local roadway that extends between Forest Street to the east and Croydon Street to the west. Bond Street is a two-lane, undivided cross-section which intersects Forest Street and Croydon Avenue at unsignalized intersections. There is no parking permitted on either side of the roadway. The posted speed limit is 50km/hr.

**Poulin Avenue** is a north-south, City-owned, local roadway that extends between Howe Street to the north and Carling Avenue to the south. Poulin Avenue is a two-lane, undivided cross-section which intersects Richmond Road at a signalized intersection and Carling Avenue at an unsignalized intersection.

### 2.5.2 Existing Study Area Intersections

#### **Carling Avenue/Alpine Street**

The Carling Avenue/Alpine Street intersection is a signalized four-way intersection. The eastbound approach consists of three through lanes and one auxiliary left-turn lane. The westbound approach consists of three through lanes and one auxiliary left-turn lane. The northbound approach consists of one full-movement lane into a commercial plaza. The southbound approach consists of one full-movement lane. There are no cycle lanes provided.

#### **Carling Avenue/Croydon Avenue**

The Carling Avenue/Croydon Avenue intersection is a signalized three-way intersection. The eastbound approach consists of three through lanes with one auxiliary left-turn lane. The westbound approach consists of three through lanes. The southbound approach consists of one auxiliary left-turn lane and one shared left and right-turn lane. There are no cycle lanes provided.

### Richmond Road/Croydon Avenue

The Richmond Road/Croydon Avenue intersection is a signalized four-way intersection. The eastbound approach consists of one through lane and one auxiliary left-turn lane. The westbound approach consists of one through lane and one auxiliary left-turn lane. The northbound and southbound approaches consist of one single full-movement lane. There are cycle lanes provided east and westbound along Richmond Road on both sides of the roadway.

### Carling Avenue/Richmond Road

The Carling Avenue/Richmond Road intersection is a signalized four-way intersection. The eastbound approach consists of two through lanes and one auxiliary left-turn lane. The westbound approach consists of three through lanes and one transit-only auxiliary left-turn lane. The northbound and southbound approaches consist of two through lanes and one auxiliary right-turn channelized lane. Left turns are not permitted on the westbound, northbound and southbound approaches. There are no cycle lanes provided.

### Richmond Road/Poulin Avenue

The Richmond Road/Poulin Avenue intersection is a signalized four-way intersection. The eastbound approach consists of one through lane and one left-turn lane. The westbound approach consists of two through lanes. The northbound approach consists of one through lane. The southbound approach consists of one through lane and one auxiliary right turn lane. Left turns are not permitted on the westbound approach. Cycle lanes are provided eastbound and westbound

There are additional three-leg, one-way, stop-controlled intersections located within the proposed development at Forest Street/Carling Avenue, Forest Street/Richmond Road, Bond Street/Forest Street and at Bond Street/Croydon Avenue.

The existing control and lane configuration at each intersection is shown below in **Figure 3**.

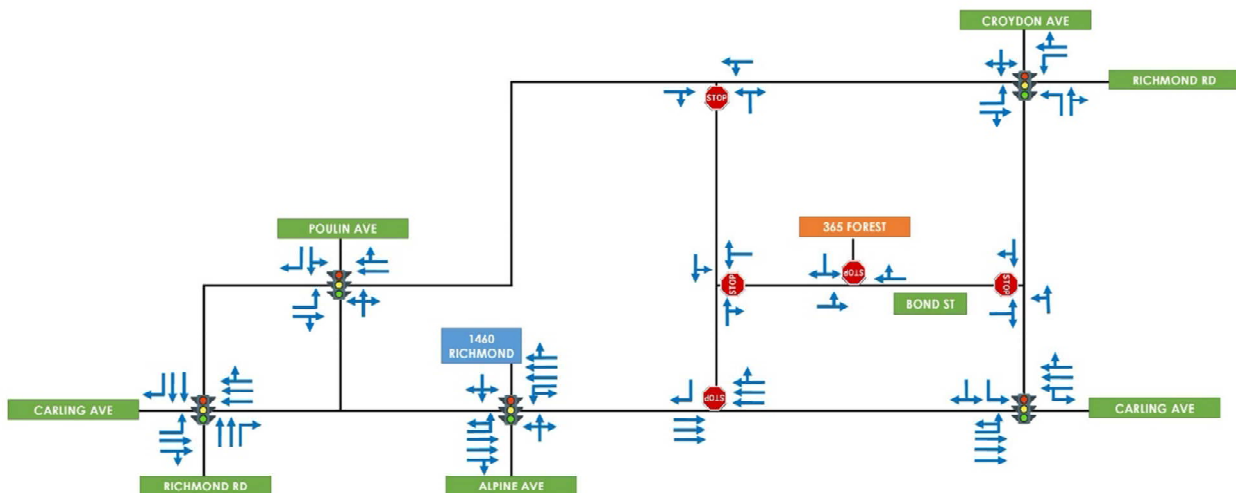

Figure 3 - Existing Traffic Control and Lane Configuration

### 2.5.3 Existing Area Traffic Measures

The existing traffic control measures for each of the boundary streets are as follows:

#### **Carling Avenue**

- Center Median
- Stop Signs at 3-way Intersections
- Sidewalks (North and South)
- Traffic Signals at Alpine Street, Croydon Avenue and Richmond Road

#### **Richmond Road**

- Stop Signs at 3-way Intersections
- Sidewalks (North and South)
- Bike Lanes
- Traffic Signal at Croydon Avenue, Poulin Avenue and Carling Avenue

#### **Croydon Avenue**

- Sidewalk (West)
- Stop Sign at 3-way Intersections
- Traffic Signals at Carling and Richmond Road

#### **Forest Street**

- Stop Signs at 3-way Intersections
- Asphalt Walkway

### 2.5.4 Existing Driveways to Adjacent Developments

The following section describes all existing driveway accesses with 200 metres of the proposed development. The location of the driveways and what land uses they correspond to are described.

There are existing residential apartment driveways located on Forest Street approximately 45m and 70m south of Richmond Road. They provide access to the apartment parking lot for the building located on the west side of Forest Street located to the west of the proposed development.

There are existing apartment driveways located on Croydon Avenue approximately 75m and 125m south of the Richmond Road intersection. They provide access to the rear parking lot (75m) and underground parking lot (125m) for the existing apartment building located to the east of the proposed development.

There is a commercial driveway entrance to a restaurant parking lot located approximately 60m southwest of the Richmond Road/Croydon Avenue intersection on Richmond Road to the northeast of the proposed development.

There is an existing commercial driveway entrance to the Albatool Fatima Association parking lot located approximately 30m west of Croydon Street on Bond Street to the southeast of the proposed development.

There are commercial driveway entrances located approximately 15m, 35m and 65m south of Richmond Road on Croydon Avenue. These driveways provide access to the existing CIBC bank (15m and 35m) and the adjacent commercial plaza located to the east of the proposed development.

There is a residential entrance to Winthrop Court Community House located approximately 105m southwest of the Richmond Road/Croydon Avenue intersection on the north side of Richmond Road.

There is a commercial plaza driveway entrance located approximately 25m north of Carling Avenue on Croydon Avenue to the southeast of the proposed development

There is an apartment building currently under construction immediately to the south of the proposed development which appears to provide access to both Bond Street and Forest Street. The proposed driveway locations are not established at this time and have therefor not been included in this report.

There are additional driveway entrances located within 200m of the proposed site driveway however these entrances are located along arterial roadways and should remain unaffected by the proposed development.

### 2.5.5 Pedestrian/Cycling Network

With respect to pedestrian traffic, sidewalks in the vicinity of the proposed development are provided along both sides of Carling Avenue and Richmond Road and along the west side of Croydon Avenue. An asphalt walkway is provided along the west side of Forest Street and there are no existing sidewalks on Bond Street.

With respect to cyclists, according to the City of Ottawa Cycling Plan, both Richmond Road and Carling Avenue are classified as “Spine” cycling routes while Forest Street, Croydon Avenue and Bond Street are not classified. Cycling facilities are currently provided on Richmond Road in the form of painted bike lanes however there are currently no bike lanes provided on Carling Avenue resulting in cyclists operating in mixed traffic.

### 2.5.6 Transit Network

Transit service within the vicinity of the site is currently provided by OC Transpo Routes #11, #51, #57 #85, and #153. Additionally, the Lincoln Fields transitway hub is close by. **Table 1** provides a list of transit stops within the immediate vicinity.

**Table 1 – Transit Stops**

Stop Location	OC Transpo Routes	Direction
Richmond / Croydon (ID 4946)	#11, #51	Southwest-bound
Richmond / Croydon (ID 6256)	#11, #51	Northeast-bound
Carling / Forest (ID 6448)	#57, #85	Westbound
Carling / Alpine (ID 4999)	#57, #85	Eastbound
Croydon / Bond (ID 5837)	#11, #51, #153	Southbound
Croydon / Lincoln Fields Mall (ID 4993)	#11, #51, #153	Northbound
Carling / Poulin (ID 6449)	#85	Westbound
Carling / Poulin (ID 2787)	#57, #85	Eastbound
Richmond / Poulin (ID 6265)	#11, #51	Southwest-bound
Richmond / Carling (ID 6422)	#85	Westbound
Richmond / Carling (ID 0865)	#85	Eastbound
Richmond / Carling (ID1555)	#11, #57	Southwest-bound
Richmond / Carling (UD 4882)	#11, #57	Northeast-bound

A detailed map of the routes and stop locations within 500 metres of the development has been provided below in **Figure 4** for reference.



**Figure 4 - Existing OC Transpo Area Network**

**Peak Hour Travel Demands**

The existing peak hour traffic volumes were collected by the City of Ottawa on the following dates:

- Croyden Avenue / Richmond Road – August 2016;
- Carling Avenue / Croyden Road – August 2016;
- Carling Avenue / Alpine Avenue – January 2018;
- Carling Avenue / Richmond Road – January 2016; and,
- Richmond Road / Poulin Avenue – August 2016.

The peak hour traffic volume count data is illustrated in **Figure 5** and is included in **Appendix C**.

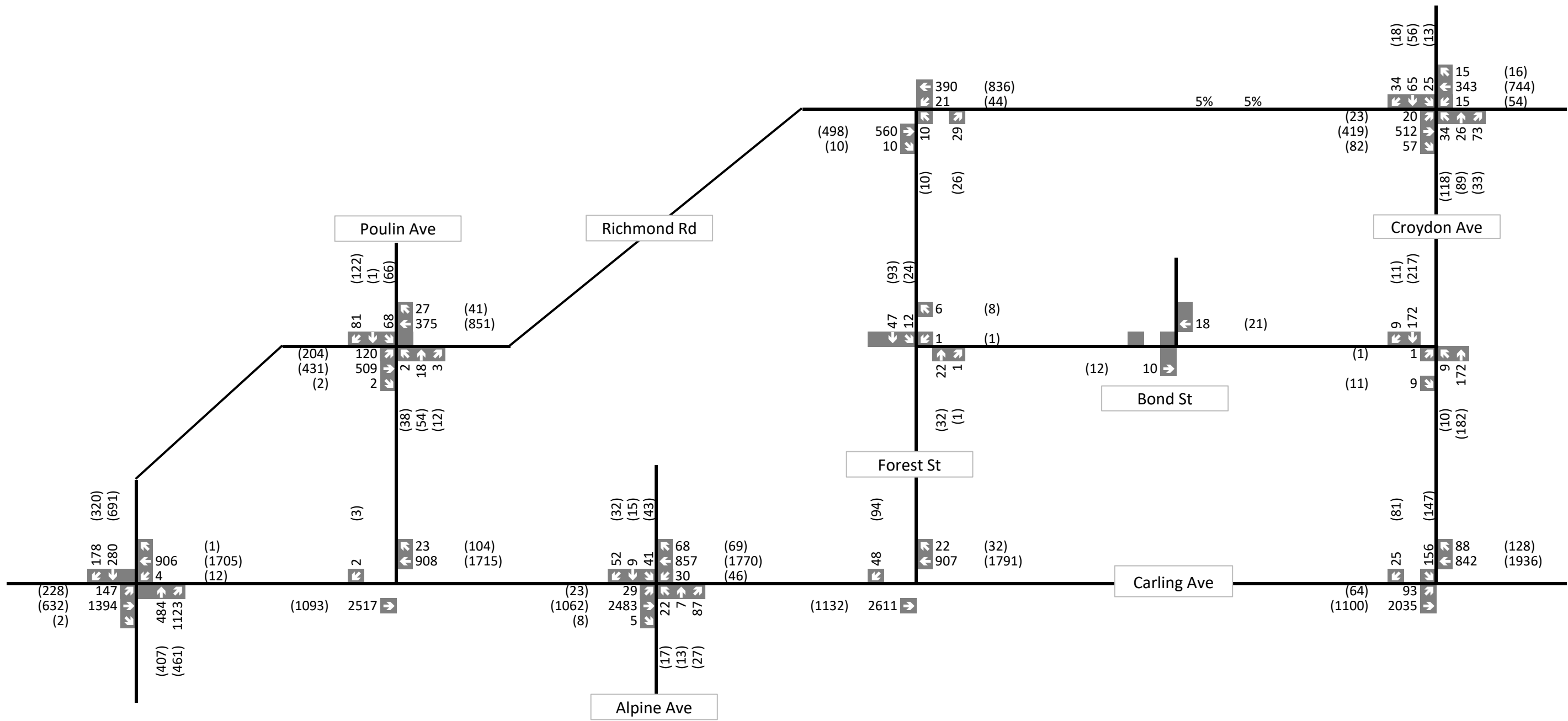

**Legend**

xx A.M. Peak Hour Traffic Volumes      (xx) P.M. Peak Hour Traffic Volumes



The existing traffic operations were assessed using Synchro software and the results provided in **Appendix D** summarized in **Table 2**. Highway Capacity Manual 6<sup>th</sup> Edition (HCM) methodology was used to determine the delay and volume over capacity ratios. Level of service is based on the *City of Ottawa Multimodal Level of Service Guidelines*.

**Table 2 – Existing Traffic Level of Service Analysis**

Intersection	Weekday AM Peak (PM Peak)					
	Critical Movements			Overall Intersection		
	LOS	v/c	Movement	Delay (s)	v/c	LOS
Signalized						
Croydon Ave / Richmond Rd	-	-	-	11.5 (15.6)	0.57 (0.72)	A (C)
Alpine Ave / Carling Ave	-	-	-	14.5 (9.2)	0.78 (0.57)	C (A)
Carling Ave / Croydon Ave	-	-	-	6.9 (12.0)	0.63 (0.66)	A (B)
Carling Ave / Richmond Rd	E	0.95	EBTR	29.3 (31.0)	1.06 (0.94)	F (E)
	(E)	(0.94)	WBTR			
Richmond Rd / Poulin Ave	-	-	-	11.0 (15.7)	0.44 (0.55)	A (A)
Unsignalized						
Carling Ave / Forest St	-	-	-	0.1 (0.3)	A (A)	-
Croydon Ave / Bond St	-	-	-	0.5 (0.5)	A (A)	-
Forest St / Bond St	-	-	-	1.7 (1.7)	A (A)	-
Forest St / Richmond Rd	-	-	-	0.9 (1.4)	A (A)	-

### 2.5.7 Existing Road Safety Conditions

- Collision history for the study area intersections (2014-2018, inclusive) was obtained from the City of Ottawa, provided in Appendix C. A summary overview of the historical collisions is listed below. The collision diagrams are provided in **Appendix E**;
- Alpine Ave / Carling Ave – 48 collisions. 8 collisions resulted in non-fatal injury. 11 angled collisions, 16 rear-end collisions, 4 sideswipe collisions and 17 turning movement collisions. Largest proportion of collisions, 11 total, occurred when an east travelling vehicle turning left struck a west travelling vehicle.
- Carling Ave / Croyden Ave – 44 collisions. 11 collisions resulted in non-fatal injury. 7 angled collisions, 9 rear-end collisions, 6 sideswipe collisions, 15 turning movement collisions, 5 single vehicle collisions and 2 unclassified collisions. Largest proportion of collisions, 9 total, occurred when an east travelling vehicle turning left struck a west travelling vehicle.
- Carling Ave / Richmond Rd – 72 collisions. 14 collisions resulted in non-fatal injury. 10 angled collisions, 40 rear-end collisions, 9 sideswipe collisions, 4 turning movement collisions, 3 single vehicle collisions and 6 unclassified collisions. Largest proportion of collisions, 8 total, occurred when an east travelling vehicle slowing or stopping struck an east travelled vehicle.

- Croydon Ave / Richmond Rd – 28 collisions. 7 collisions resulted in a non-fatal injury. 5 angled collisions, 12 rear-end collisions, 6 turning movement collisions, 4 single vehicle collisions and 1 unclassified collision. Largest proportion of collisions, 10 total, occurred when a vehicle on Richmond Rd (east or west) going at regular speed rear-ended a vehicle travelling in the same direction.
- Poulin Ave / Richmond Road – 23 collisions. 6 collisions resulted in a non-fatal injury. 5 angled collisions, 5 rear-end collisions, 2 sideswipe collisions, 7 turning movement collisions, 3 single vehicle collisions and 1 uncategorized collision. No obvious outlier appears in the data, however 11 collisions were caused by an east travelling vehicle.

## 2.6 Planned Conditions

### 2.6.1 Transportation Network Plans

Arterial road widening is proposed on Richmond Road between Highway 417 and Carling Avenue as identified on the 2031 Road Network Concept (Map 10 of the City of Ottawa Transportation Master Plan).

A transit rail station is proposed at the Carling/Sir John A. Macdonald Parkway as identified on the Rapid Transit and Transit Priority – 2031 Network Concept and Affordable Network Plans (Maps 4 and 5 of the City of Ottawa Transportation Master Plan). Additionally, Carling Avenue between Richmond Road and the Confederation Line, and Richmond Road between Carling Avenue and Holly Acres Road is defined as a Transit Priority Corridor, with continuous transit lanes.

### 2.6.2 Other Developments

Based on our review of the study area, the proposed developments located near the study area are as follows:

- **2525 Carling Avenue** – The Site Plan Control application for 2525 Carling Avenue has been submitted for the proposed demolition of the existing shopping centre located at to facilitate the construction of a new shopping centre surrounding the future LRT station proposed at Lincoln Fields. The proposed development consists of two, two-storey retail buildings which are approximately 28,300sqft and 16,800sqft in Gross Floor Area. The proposed development is located on the east side of Croydon Avenue adjacent to the proposed development.
- **2583 Carling Avenue & 2599 Carling Avenue** - The Site Plan Control and Zoning Bylaw Amendment application for the 2583 and 2599 Carling Avenue has been submitted for a proposed Dymon self-storage facility which is comprised of a 136,000 sqft storage facility with an additional 10,000sqft retail space. The proposed development will be accessed via Carling Avenue, Forest Street and Bond Street.
- **351 Croydon Avenue** – The Site Plan Control Application for 351 Croydon Avenue has been submitted for a proposed residential building. The proposed building is 3-storeys and contains 8 residential units.

## 2.7 Exemptions Review

The proposed development satisfies the Trip Generation Trigger, the Location Trigger and the Safety Trigger. Based upon Table 4 in the City of Ottawa Traffic Impact Assessment Guidelines, there are no exemptions identified for the proposed development.

## 3 Forecasting

### 3.1 Proposed Development

#### 3.1.1 Mode Share

The subject development is located within the Bayshore/Cedarview neighbourhood, with the existing travel mode breakdown provided in **Table 3**.

**Table 3 – Existing Travel Mode Proportions**

Travel Mode	AM PEAK			PM PEAK		
	From District	To District	Proportion	To District	Within District	Proportion
Auto Driver	73150	73010	64%	73010	34470	57%
Auto Passenger	18520	18710	16%	18710	10600	16%
Transit	17480	17570	15%	17570	5270	12%
Bicycle	1200	1130	1%	1130	1160	1%
Walk	1210	1120	1%	1120	15610	9%
Other	3150	3270	3%	3270	5710	5%

Due to the proximity of the Lincoln Fields station, a greater transit mode share is considered to be more accurate for the study area. Additionally, at request of City, future travel mode proportions examined. Based on the City's *Transit-Oriented Development Plans*, the City has planned for a target transit mode share of up to 65%. Additionally, the City's target active transportation mode share is 15% and is expected to be exceeded by an additional 5% due to the abundant presence of cycling infrastructure. Therefore, a projected auto mode share of 15% in the AM and 11% in the PM are expected for this development. The existing mode shares have been adjusted based on these targets and assumptions and are outlined as the future target mode shares in **Table 4**.

**Table 4 – Future Target Travel Mode Proportions**

Future	AM PEAK		PM PEAK	
	Proportion	Adjustment	Proportion	Adjustment
<b>Auto Driver</b>	15%	-49%	11%	-46%
<b>Auto Passenger</b>	5%	-11%	5%	-11%
<b>Transit</b>	65%	50%	65%	53%
<b>Bicycle</b>	11%	10%	5%	4%
<b>Walk</b>	1%	0%	9%	0%
<b>Other</b>	3%	0%	5%	0%

Based on the projected mode shares, the overall auto mode share for the site would be 15% in the morning peak hour and 11% in the afternoon peak hour.

### 3.1.2 Development-Generated Travel Demand

Trip generation for the proposed development were derived from the 2009 TRANS Trip Generation Study. The trip generation is summarized in **Table 5** for the separate phases. The rates were derived from Table 6.3 in the study, outlining the vehicle trips for the land use type. Person trips were derived from Table 3.13 in the same study. Based on the mode share proportions outlined in Section 3.1.2, 15% of AM trips and 11% of PM trips are expected to be vehicular.

**Table 5 – Trip Generation – Subject Site**

Land Use	Independent Variable	Parameters	AM Peak Hour		PM Peak Hour	
			In	Out	In	Out
High-Rise Apartments (10+ Floors) (2009 TRANS Trip Generation Study)	391 dwelling units	Scenario	Urban, Base Rate		Urban, Base Rate	
		Rate / Eq.	0.24		0.27	
		Total Trips	94		106	
		Person Trips	254		265	
		Auto Trip Prop.	15%		11%	
		Auto Trips	38		32	
		Distribution	24%	76%	62%	38%
		New Auto Trips	9	29	20	12

The proposed development is expected to generate a total of 119 two-way person trips, of which 38 are vehicle trips during the AM peak hour. The development is expected to generate 124 two-way person trips, of which 29 are vehicle trips during the PM peak hour. Both phases are expected to be built-out by the horizon year in 2024.

### 3.1.3 Trip Distribution

The trip distribution for the proposed development is based on existing AM and PM peak hour traffic volumes and summarized in **Table 6**.

**Table 6 - Trip Distribution - Existing Traffic**

Direction	Via (To / From)	In	Out
North	Croydon Avenue	2%	2%
South	--	--	--
East	Richmond Road	12%	12%
	Carling Avenue	39%	39%
West	Richmond Road	15%	15%
	Carling Avenue	31%	31%

### 3.1.4 Trip Assignment

The site traffic for the proposed development is provided in **Figure 6**.

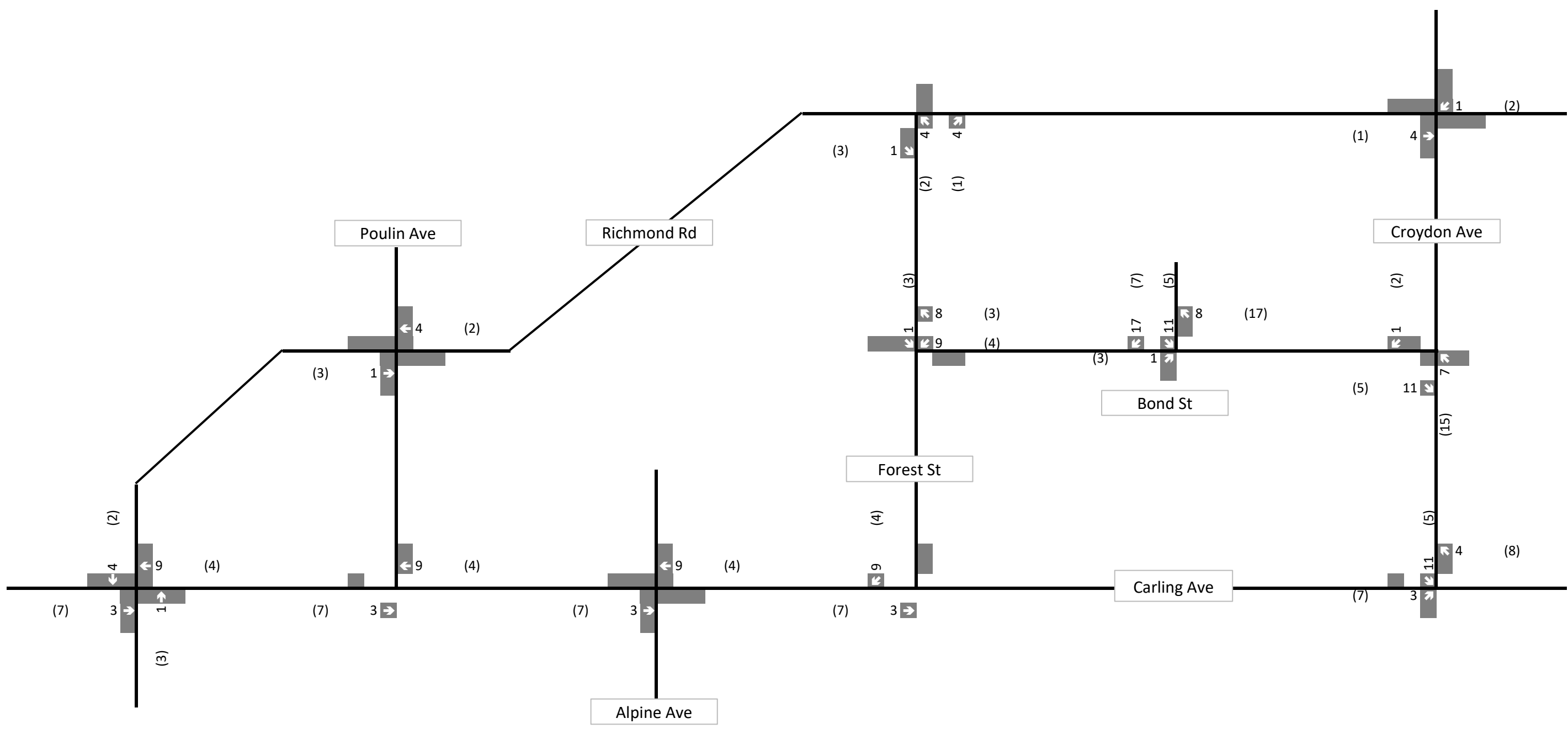

Legend

xx A.M. Peak Hour Traffic Volumes (xx) P.M. Peak Hour Traffic Volumes



Figure 6  
Site Trips - Subject Site

## 3.2 Background Network Travel Demands

### 3.2.1 Transportation Network Plans

A transit rail station is planned at the Carling/Sir John A. Macdonald Parkway as identified on the Rapid Transit and Transit Priority – 2031 Network Concept and Affordable Network Plans (Maps 4 and 5 of the City of Ottawa Transportation Master Plan). This transit rail station is the Lincoln Fields station for the Confederation Line west extension, which is expected to be operational in 2025.

Arterial road widening is proposed on Richmond Road between Highway 417 and Carling Avenue as identified on the 2031 Road Network Concept (Map 10 of the City of Ottawa Transportation Master Plan). No information beyond the concept is provided and it is assumed this project will take place after the 5-year post-build out.

Additionally, Carling Avenue between Richmond Road and the Confederation Line, and Richmond Road between Carling Avenue and Holly Acres Road is defined as a Transit Priority Corridor, with continuous transit lanes.

### 3.2.2 Background Traffic Growth

Background traffic growth for the study area was obtained based on the *RioCan – 2525 Carling Avenue – Lincoln Fields Shopping Centre Traffic Impact Assessment Report* (prepared by Parsons) which uses a 2% per annum growth rate for the study area. This growth rate was not applied to Forest Street or Bond Street due to the local nature of these roads which are not impacted traffic from outside of the study area.

### 3.2.3 Other Developments

Based on our review of the study area, the proposed developments located near the study area are as follows:

- **2525 Carling Avenue** - The *RioCan – 2525 Carling Avenue – Lincoln Fields Shopping Centre Traffic Impact Assessment Report* (prepared by Parsons) indicates the proposed development is projected to generate approximately 30 vehicles/hour and 451 vehicles/hour during the morning and afternoon peak hours, respectively.
- **2583 Carling Avenue & 2599 Carling Avenue** - Based upon the proposed use of the facility and anticipated traffic volumes from the site, the overall traffic impacts are considered negligible.
- **351 Croydon Avenue** - Based upon the limited size of this development, a Traffic Impact Study was not completed for the development and it is anticipated the overall traffic impacts are considered negligible.

## 3.3 Demand Rationalization

### 3.3.1 Future (2024) Background Traffic

The future (2024) background traffic volumes are provided in **Figure 7**.

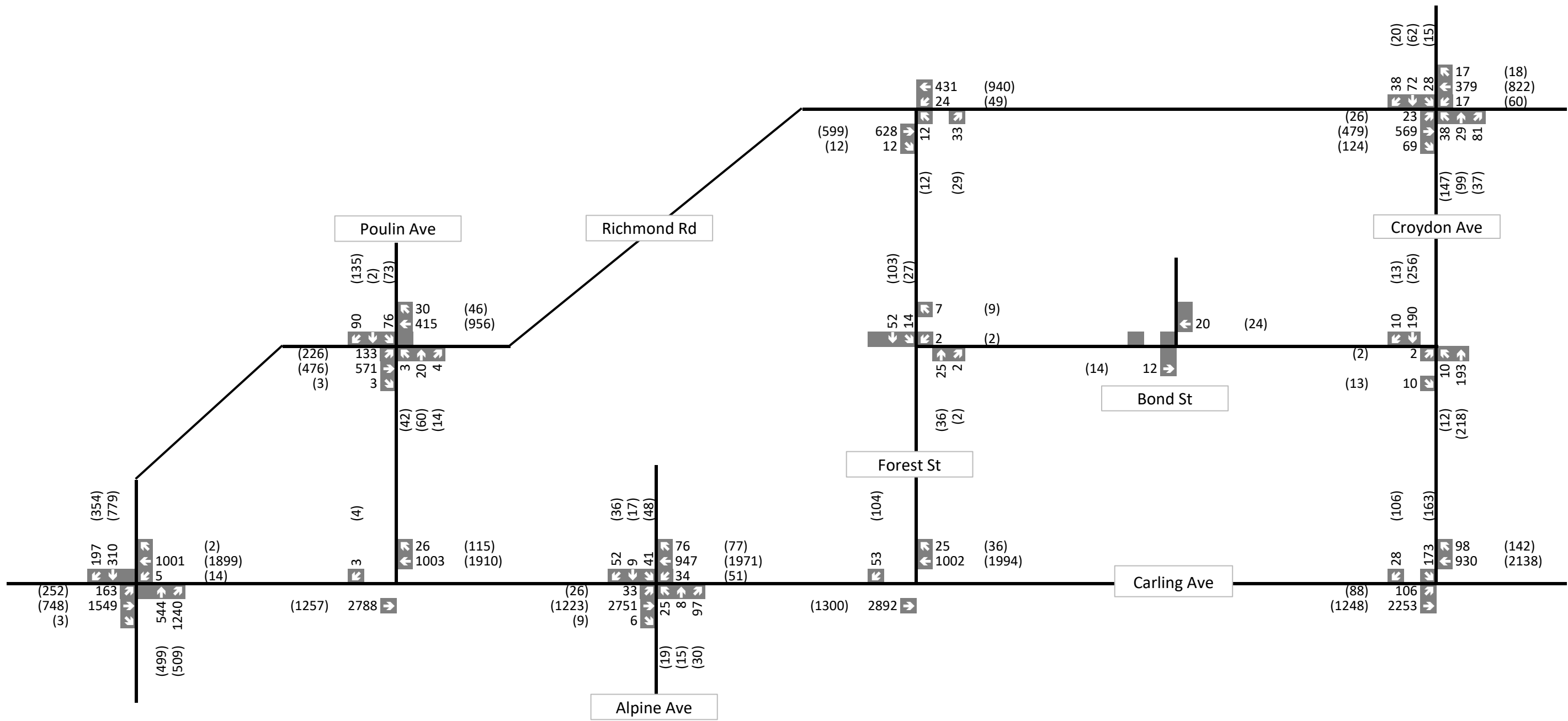

**Legend**

xx A.M. Peak Hour Traffic Volumes      ((xx)) P.M. Peak Hour Traffic Volumes



**Figure 7**  
Future (2024)  
Background Traffic Volumes

The future (2024) background traffic analysis is assessed using Synchro software and is the outputs provided in **Appendix F** and summarized in **Table 7**.

**Table 7 - Future (2024) Background Traffic Analysis**

Intersection	Weekday AM Peak (PM Peak)					
	Critical Movement			Overall Intersection		
	LOS	v/c	Movement	Delay (s)	v/c	LOS
<b>Signalized</b>						
Croydon Ave / Richmond Rd	-	-	-	11.5 (16.6)	0.57 (0.74)	A (C)
Alpine Ave / Carling Ave	-	-	-	9.5 (9.5)	0.76 (0.57)	C (A)
Carling Ave / Croydon Ave	-	-	-	6.9 (13.1)	0.63 (0.67)	B (B)
Carling Ave / Richmond Rd	E	0.95	EBTR	28.3 (31.3)	1.05 (0.95)	F (E)
	(E)	(0.94)	WBTR			
Richmond Rd / Poulin Ave	-	-	-	11.0 (16.5)	0.44 (0.56)	A (A)
<b>Unsignalized</b>						
Carling Ave / Forest St	-	-	-	0.1 (0.3)	A (A)	-
Croydon Ave / Bond St	-	-	-	0.5 (0.5)	A (A)	-
Forest St / Bond St	-	-	-	1.8 (1.7)	A (A)	-
Forest St / Richmond Rd	-	-	-	1.0 (1.5)	A (A)	-

All critical movements in the study area are expected to occur at Carling Ave and Richmond Road. During the AM peak hour, the eastbound through-right is considered as a critical movement but would operate within capacity. During the PM peak hour westbound through-right is critical and would also operate within capacity. The overall intersection is considered critical during the AM peak hour and would operate slightly over capacity.

None of the unsignalized movements or intersections are considered critical.

### 3.3.2 Future (2029) Background Traffic

The future (2029) background traffic volumes are provided in **Figure 8**.





The future (2029) background traffic analysis is assessed using Synchro software and is the outputs provided in **Appendix F** and summarized in **Table 8**.

**Table 8 - Future (2029) Background Traffic Analysis**

Intersection	Weekday AM Peak (PM Peak)					
	Critical Movement			Overall Intersection		
	LoS	v/c	Movement	Delay (s)	v/c	LOS
<b>Signalized</b>						
Croydon Ave / Richmond Rd	-	-	-	12.4 (27.2)	0.63 (0.81)	B (D)
Alpine Ave / Carling Ave	-	-	-	10.9 (10.9)	0.84 (0.64)	D (B)
Carling Ave / Croydon Ave	-	-	-	7.2 (15.2)	0.69 (0.75)	B (C)
Carling Ave / Richmond Rd	(E)	(0.92)	EBL	37.2 (48.9)	1.16 (1.05)	F (F)
	F	1.04	EBTR			
	(F)	(1.09)	WBTR			
	E	0.92	NBR			
Richmond Rd / Poulin Ave	-	-	-	11.3 (19.0)	0.49 (0.64)	A (B)
<b>Unsignalized</b>						
Carling Ave / Forest St	-	-	-	0.1 (0.3)	A (A)	-
Croydon Ave / Bond St	-	-	-	0.5 (0.5)	A (A)	-
Forest St / Bond St	-	-	-	1.8 (1.7)	A (A)	-
Forest St / Richmond Rd	-	-	-	1.0 (2.1)	A (A)	-

Compared to the 2024 background conditions, a couple of new critical movements appear at Carling Avenue and Richmond Road. During the AM peak hour, the northbound right is considered critical. During the PM peak hour, the eastbound left is considered critical. Both critical movements previously identified are now over capacity. Additionally, the overall intersection in the PM peak hour is considered over capacity. No issues arise at other signalized intersections.

No unsignalized movements are critical, although it is noted that the northbound left-right at Forest Street and Richmond Road is LOS 'E' in the PM peak hour.

## 4 Analysis

### 4.1 Development Design

The proposed development is to have a single driveway access on Forest Street located approximately 70 meters south of Richmond Road. The access is located on a low volume street and provides driveway access to the underground parking garage. There is also a proposed lay-by located on Forest Street to allow pick up and drop offs to occur on-street.

### 4.2 Parking

The proposed development is providing 431 parking spaces in an underground parking garage accessible via Bond Street. The current site plan indicates 561 spaces, however the development is considering a reduction in the parking spaces, assuming 1.1 parking spaces per unit, with 1.0 attributed to the unit and 0.1 attributed to the visitor considerations.

The proposed development is providing 202 bicycle parking spaces. The site plan indicates that 90 spaces will be outside the building at ground level: 50 will be located to the northwest along Tower B, 10 will be located under a covering north of Tower A, and 30 will be located to the west of the roundabout. The remaining spaces will be contained in the buildings. Both buildings will contain rooms with 56 spaces.

### 4.3 Boundary Streets

The boundary streets of the development include Richmond Road, Carling Avenue, Croydon Avenue, Forest Street and Bond Street. The proposed development is not expected to change the configuration of the boundary street roads. The Multimodal Level of Service for the boundary road segments is summarized in **Table 9**.

**Table 9 – Multimodal Level of Service**

Segment	Pedestrian	Cycling	Transit	Truck
Richmond between Forest/Croydon	B	A	D	C
Croydon between Richmond/Carling	C	D	D	-
Carling between Alpine/Croydon	D	D	D	A
Forest between Richmond/Carling	B	B	-	-
Bond between Forest/Croydon	F	B	-	-
Richmond between Forest/Poulin	B	B	D	C
Richmond between Poulin/Carling	C	B	D	B
Carling between Alpine/Poulin	C	F	D	A
Carling between Poulin/Richmond	C	F	D	A

The Pedestrian level of service can be improved along Bond Street by installing a sidewalk along its length.'

The collisions outlined in Section 2.5.7 were further analyzed to determine any prevailing patterns, which the City's TIA guidelines indicate as the same collision occurring 6 times or greater in a span of five years. **Table 10** outlines the patterns found.

**Table 10 - Reoccurring Collision Analysis**

Intersection	Collision Type	Collision Number	Vehicle 1 Direction	Vehicle 2 Direction
Carling Ave & Alpine Avenue	Angled	11	Eastbound, making left turn	Westbound, going ahead
Carling Ave & Croydon Avenue	Angled	9	Eastbound, making left turn	Westbound, going ahead
Richmond Rd & Carling Ave	Angled	6	Northbound, going ahead	Eastbound, going ahead
	Rear End	7	Eastbound, slowing or stopping	Eastbound, stopped
		6	Westbound, going ahead	Westbound, stopped

All prevailing patterns in the study area are related to Carling Avenue, especially at its intersection with Richmond road where both through movements have rear end collision patterns. The highest frequency of collisions occur at Carling Avenue and Alpine Avenue where left turning vehicles accessing the plaza collided with through westbound vehicles.

Collisions, especially the eastbound left turns on Carling Avenue, are more common during the PM peak period, between 3:00 PM and 6:00 PM. This could be attributed to high westbound volume during that time period, and the lack of acceptable gaps for turning vehicles.

Some mitigative measures to reduce collisions could be considered by the City as follows:

- Activate eastbound left turn phase at Carling Avenue and Alpine Avenue during AM peak period to reduce number of conflicts between eastbound left turning vehicles and westbound through vehicles.
- Turning movement collisions at Carling Avenue and Croydon Avenue may be mitigated by having the exclusive eastbound left turn phase protected only.
- An evaluation of the Richmond Road and Carling Avenue intersection is recommended to determine appropriate mitigative measures for both capacity restraints and collision patterns. A future realignment of the intersection could improve visibility for road users.

#### 4.4 Access Intersections

The proposed development will have two access locations – a roundabout on Forest Avenue and a garage access on Bond Street. The roundabout will not connect to any parking locations at the development; instead the access is primarily used for emergency vehicles and pick-up drop-off trips. The access is 7.5 meters wide.

The garage access on Bond Street will be 7 meters wide and provide access to the underground parking garage. Both buildings will be directly accessible via the garage.

#### 4.5 Transportation Demand Management

The proposed development is expected to have a non-auto modal split of 85% during the AM peak hour and 89% during the PM peak hour due to the availability of transit and other facilities in the area. As a result, the development is installing sidewalks on-site to connect the development to the City’s sidewalk network as well as providing 194 bicycle parking spaces.

Encouragement of non-auto modes of travel and reduction of single occupant vehicle (SOV) trips is provided through a list of recommendations proved by the City. Acceptable measures based on the City are provided in **Table 11**.

**Table 11 - TDM Checklist**

Category	TDM Measure	Description	Proposed?
TDM Program Management	Program Coordinator	It is recommended that a TDM Coordinator be designated to manage the implementation and ongoing support of TDM measures. The TDM Coordinator should liaise with both the residential and non-residential parties to prepare an integrated approach.	Yes
	Travel Surveys	It is recommended that a travel survey be conducted when the site reaches a minimum of 50% occupancy to establish a baseline. Following this, a follow-up survey should be conducted on a periodic basis to measure the success of the recommended TDM measures and to identify areas for improvement.	Yes
Walking and Cycling	Information on Active Transportation Routes and Destinations	Information on nearby walking / cycling routes should be prepared in a TDM information package and provided for all residents.	Yes
	Bicycle Skills Training	If there is an appropriate level of interest in training, a bicycle training session could be made available. Services are made available from organizations such as CAN-BIKE which offer both online and in-person training sessions. The provision of these sessions would be subject to the owner's discretion.	Yes
Transit	Transit Information	Information on nearby transit routes should be made available in the TDM information package. The information should be discussed with OC Transpo staff to ensure the appropriate information is provided.	Yes
		Provide real-time arrival information displays in building lobbies.	Yes
	Transit Fare Incentives	It is recommended for a subsidized transit pass to be provided for all first-time residents within the first year of occupancy. It is recommended that the subsidized transit pass should be distributed when the building reaches a minimum of 50% occupancy. The exact value and provision of these transit passes is subject to the Owner's Discretion.	Yes
Carsharing & Bikes sharing	Bikeshare Memberships	Should a bike share network be made available within the area, subsidized memberships or provision of a bikeshare location could be considered for both employees and residents.	Yes

	Bikeshare Stations	A bike share station should be considered based on appropriateness and consultation with a local bikeshare company.	Dependent on consultation
	Carshare Vehicles & Membership	Should a car share network be made available within the area, subsidized memberships or carshare spaces could be considered.	Yes
Parking	Priced Parking	For residential spaces, parking should be unbundled from each unit and paid for separately.	Yes
TDM Marketing & Communications	Multimodal Travel Information	A TDM information package should be prepared for residential uses. The package should provide information on available active transportation networks and programs, transit networks and TDM programs.	Yes
	Personalized Trip Planning	A TDM specialist could be invited to offer personalized trip planning to new residents. This would help them to explore their options on the available travel modes to best select one that would suit their lifestyle.	Yes

#### 4.6 Neighbourhood Traffic Management

All site traffic is expected to be accommodated on Forest Street and Bond Street. No modifications are required to limit impact to the surrounding neighbourhoods.

#### 4.7 Transit

Based on the mode share proportions derived in Section 3.1.1, 65% of development site trips are expected to be through transit. The development will generate 254 AM peak hour person trips and 265 PM peak hour person trips, which translate to 165 AM peak hour transit trips and 172 PM peak hour transit trips.

The future Confederation Line West and redeveloped Lincoln Fields Station will considerably increase transit availability in the area. The extension of the Confederation Line is expected to be completed in 2025, during the development's horizon years.

Transit requirements in the area would be monitored by OC Transit and would determine future capacity. The transit trips generated by the proposed development have been identified in Section 3.1.1. The transit capacity would be determined by OC Transit for both existing and projected conditions.

#### 4.8 Network Concept

The road network is not expected to change within the duration of this report.

#### 4.9 Network Intersections

##### 4.9.1 Vehicular Level of Service

##### 4.9.1.1 Future (2024) Total Traffic

The future (2024) total traffic volumes are provided in **Figure 9**.

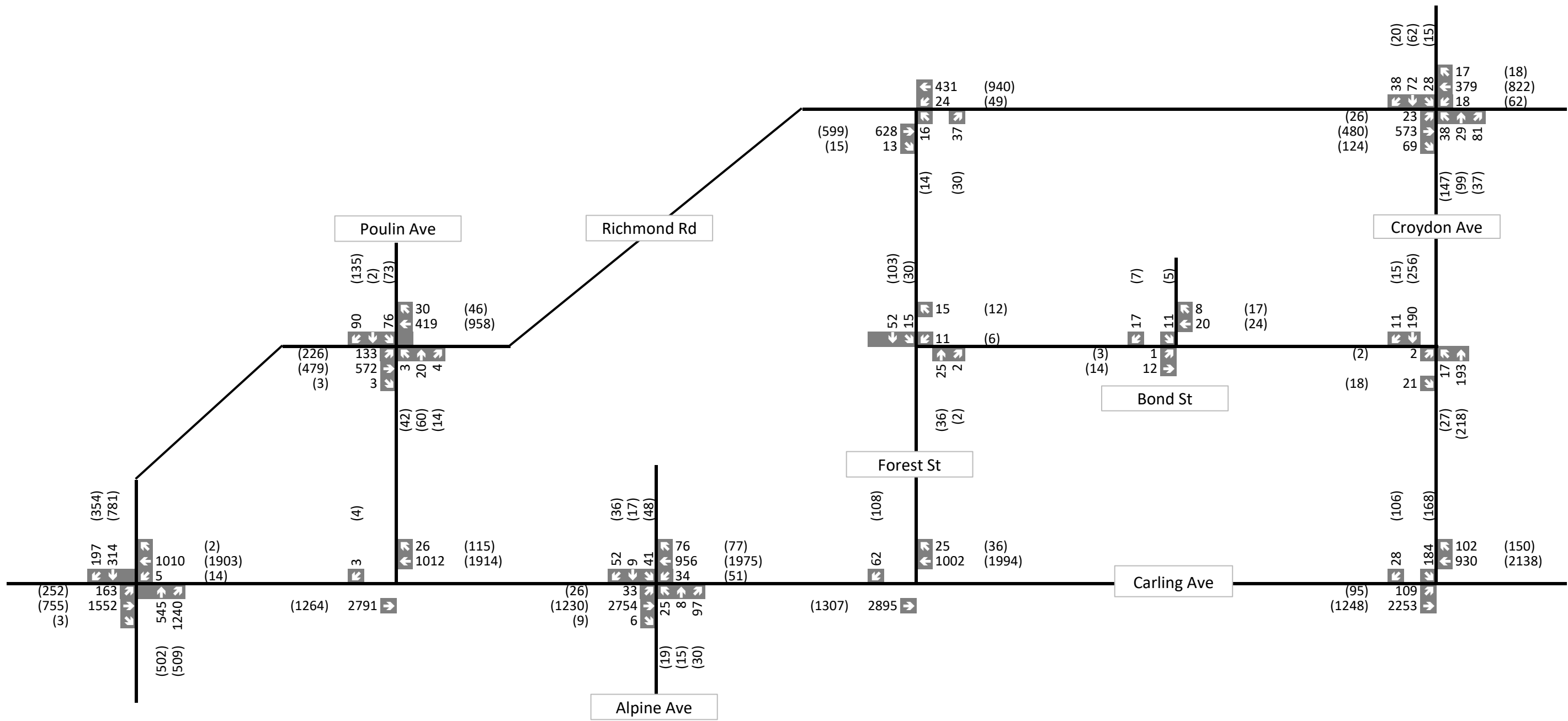

**Legend**

xx A.M. Peak Hour Traffic Volumes      (xx) P.M. Peak Hour Traffic Volumes



**Figure 9**  
Future (2024) Total Traffic Volumes

The future (2024) total traffic analysis is assessed using Synchro software with the outputs provided in **Appendix G** and summarized in **Table 12**.

**Table 12 - Future (2024) Total Traffic Analysis**

Intersection	Weekday AM Peak (PM Peak)					
	Critical Movement			Overall Intersection		
	LOS	v/c	Movement	Delay (s)	v/c	LOS
<b>Signalized</b>						
Croydon Ave / Richmond Rd	-	-	-	11.5 (16.5)	0.58 (0.74)	A (C)
Alpine Ave / Carling Ave	-	-	-	9.5 (9.7)	0.77 (0.57)	C (A)
Carling Ave / Croydon Ave	-	-	-	7.2 (13.8)	0.63 (0.68)	B (B)
Carling Ave / Richmond Rd	E	0.95	EBTR	28.3 (32.0)	1.06 (0.95)	F (E)
	(E)	(0.94)	WBTR			
Richmond Rd / Poulin Ave	-	-	-	11.0 (16.5)	0.44 (0.56)	A (A)
<b>Unsignalized</b>						
Carling Ave / Forest St	-	-	-	0.1 (0.3)	A (A)	-
Croydon Ave / Bond St	-	-	-	0.9 (0.8)	A (A)	-
Forest St / Bond St	-	-	-	2.8 (2.1)	A (A)	-
Forest St / Richmond Rd	-	-	-	1.0 (1.6)	A (A)	-
Bond St / 365 Forest	-	-	-	3.6 (1.8)	A (A)	-

Compared to the 2024 background conditions, no additional movements are critical. The site trips added to the road network will not have any noticeable impact on the conditions. Additionally, no unsignalized movements are considered critical.

#### 4.9.1.2 Future (2029) Total Traffic

The future (2029) total traffic volumes are provided in **Figure 10**.



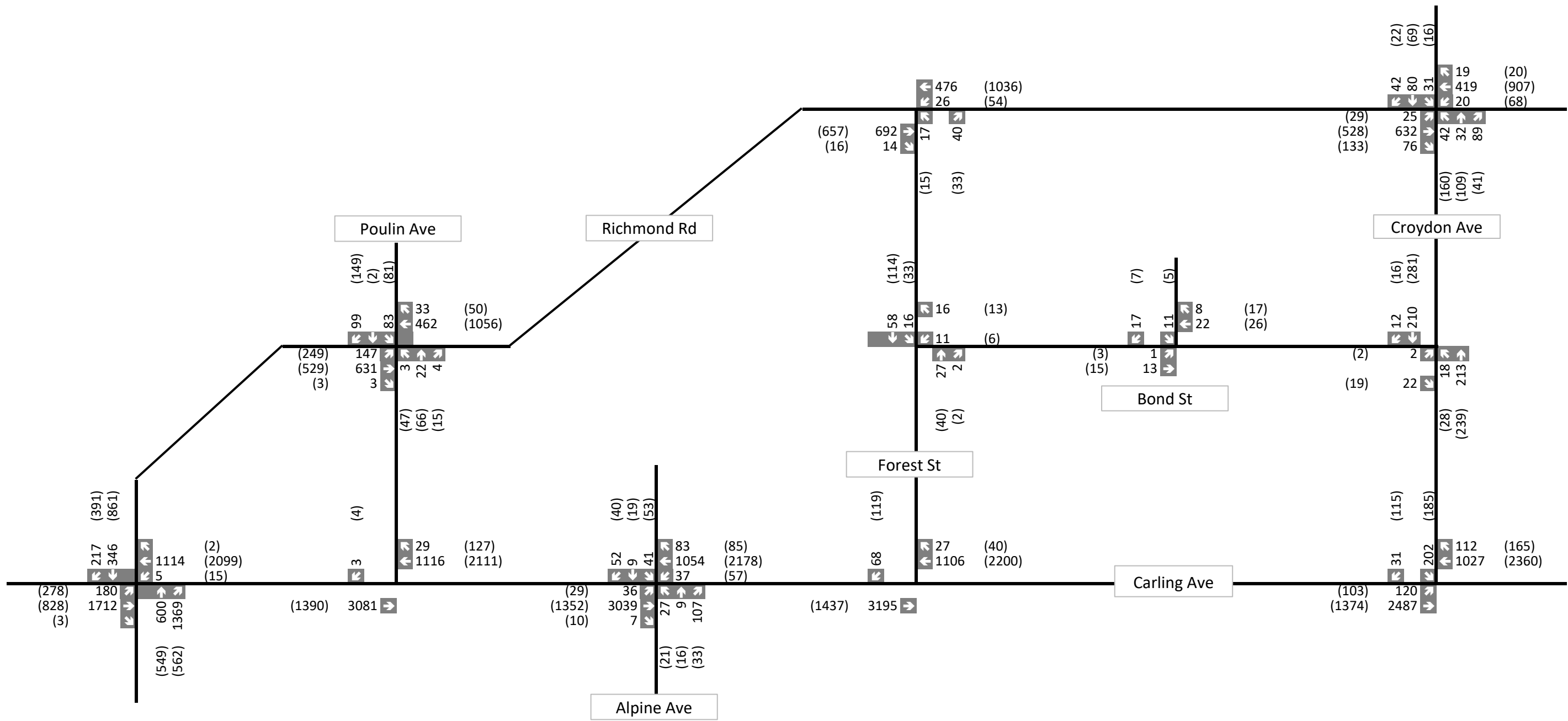

**Legend**

xx A.M. Peak Hour Traffic Volumes      (xx) P.M. Peak Hour Traffic Volumes



Figure 10  
Future (2029) Total Traffic Volumes

The future (2029) total traffic analysis is assessed using Synchro software and is the outputs provided in **Appendix G** and summarized in **Table 13**.

**Table 13 - Future (2029) Total Traffic Analysis**

Intersection	Weekday AM Peak (PM Peak)					
	Critical Movement			Overall Intersection		
	LoS	v/c	Movement	Delay (s)	LoS	v/c
<b>Signalized</b>						
Croydon Ave / Richmond Rd	-	-	-	12.4 (19.8)	0.64 (0.81)	B (D)
Alpine Ave / Carling Ave	-	-	-	10.9 (11.0)	0.85 (0.64)	D (B)
Carling Ave / Croydon Ave	-	-	-	7.5 (16.0)	0.70 (0.76)	B (C)
Carling Ave / Richmond Rd	(E)	(0.92)	EBL	37.4 (49.3)	1.16 (1.05)	F (F)
	F	1.05	EBTR			
	(F)	(1.10)	WBTR			
	E	0.92	NBR			
Richmond Rd / Poulin Ave	-	-	-	11.4 (19.1)	0.49 (0.64)	A (B)
<b>Unsignalized</b>						
Carling Ave / Forest St	-	-	-	0.1 (0.4)	A (A)	-
Croydon Ave / Bond St	-	-	-	0.8 (0.8)	A (A)	-
Forest St / Bond St	-	-	-	2.8 (2.1)	A (A)	-
Forest St / Richmond Rd	-	-	-	1.1 (2.3)	A (A)	-
Bond St / 365 Forest	-	-	-	3.5 (1.7)	A (A)	-

Compared to the 2029 background conditions, no additional movements are considered critical. The analysis indicates that the site trips will have minimal impact on the road network in the 10-year horizon. Additionally, no capacity issues arise from unsignalized intersections.

#### 4.9.2 Multimodal Level of Service

A multi-modal level of service was conducted at the signalized intersections within the study area and the results summarized in **Table 14**.

**Table 14 – Intersection Multimodal Level of Service Analysis**

Intersection	Pedestrian	Cycling	Transit	Truck	Auto
Richmond & Croydon	D	A	C	-	B
Carling & Croydon	F	F	A	-	B
Carling & Alpine	F	F	E	-	B
Richmond & Carling	E	F	F	D	E
Richmond & Poulin	D	F	C	-	A

Although the pedestrian and cycling operate level of service F along Carling Avenue, major reconstruction of Carling Avenue would be required improve these scores, which is beyond the scope of this project.

### 4.9.3 Network Mitigation

At the request of the city, a left turn lane warrant for the westbound left on Richmond Road at Forest Avenue was conducted to determine the feasibility for an exclusive lane. **Appendix H** outlines the results of the warrant analysis, determining that a 25 meter lane is warranted in the existing PM traffic conditions, and both peak hours are warranted by the future 2029 background conditions.

However, it is noted that the left turn volumes at the intersection were derived under an assumption based on 5% of the downstream traffic. Counts were unable to be completed at this intersection due to the COVID-19 pandemic occurring during the initial report submission. It is recommended at the City of Ottawa formally confirm the traffic patterns at this intersection to determine if the percentage of left turn traffic to advancing traffic is accurate at 5%.

The warrant should be reevaluated based on traffic survey volumes at the intersection.

Based on the level of service analysis and collision patterns analysis, the following mitigative measures were applied to the 2029 future total conditions:

- Carling Avenue & Richmond Road
  - Signal phases were altered to better accommodate traffic patterns in the AM and PM peak hours.
  - The timing structure of the intersection was not altered.
- Carling Avenue & Alpine Avenue
  - The eastbound left turn phase was added during the AM peak hour.
- Carling Avenue & Croydon Avenue
  - The eastbound left turn phase was changed to protected only.
- Richmond Road & Forest Street
  - A westbound left turn lane with a 25 metre storage lane was added.

The future (2029) total traffic analysis is assessed using Synchro software and is the outputs provided in **Appendix I** and summarized in **Table 15**. Timing information is included in the outputs.

**Table 15 - Future (2029) Total Mitigated Traffic Analysis**

Intersection	Weekday AM Peak (PM Peak)					
	Critical Movement			Overall Intersection		
	LoS	v/c	Movement	Delay (s)	LoS	v/c
<b>Signalized</b>						
Croydon Ave / Richmond Rd	-	-	-	12.4 (19.6)	0.64 (0.81)	B (D)
Alpine Ave / Carling Ave	-	-	-	11.2 (12.0)	0.84 (0.64)	D (B)
Carling Ave / Croydon Ave	-	-	-	11.3 (20.7)	0.70 (0.78)	B (C)
Carling Ave / Richmond Rd	(E)	(0.99)	EBL	37.7 (44.2)	1.16 (1.05)	F (F)
	F	1.05	EBTR			
	(F)	(1.06)	WBTR			
	E	0.92	NBR			
Richmond Rd / Poulin Ave	-	-	-	11.9 (19.1)	0.49 (0.64)	A (B)
<b>Unsignalized</b>						
Carling Ave / Forest St	-	-	-	0.1 (0.4)	A (A)	-
Croydon Ave / Bond St	-	-	-	0.8 (0.8)	A (A)	-
Forest St / Bond St	-	-	-	2.8 (2.1)	A (A)	-
Forest St / Richmond Rd	-	-	-	1.0 (1.4)	A (A)	-
Bond St / 365 Forest	-	-	-	3.5 (1.7)	A (A)	-

The mitigative measures applied to Carling Avenue and Alpine Avenue, and Carling Avenue and Croydon Avenue have negligible changes in the operations analysis. Changes made regarding collision patterns will not have a major negative impact on the network. The addition of the westbound left turn lane at Richmond Road / Forest Street reduces the overall intersection delays in both peak hours.

Due to the timing plan of the Carling Avenue and Richmond Road intersection, specifically the transit specific signaling on the exclusive eastbound-left, signal optimizations were limited. It is recommended that the City monitor the intersection for future improvements.

## 5 Conclusions and Recommendations

Based on the analysis, our conclusions and recommendations are as follows:

- The development proposal is for a total of 391 residential units with a single access to Bond Street;
- Based on our review of the area, the site is well served by transit and experiences a non-auto modal split of 85% during the AM peak hour and 89% during the PM peak hour;
- The 2525 Carling Avenue redevelopment is the only significant background development in the area and is included in our study;
- A 2% growth rate was applied to the study area road network;
- The proposed development is expected to generate a total 254 person trips during the AM peak hour and 265 person trips during the PM peak hour. Of these, the auto trip generation is expected to be 38 during the AM peak and 32 during the PM peak hour;
- The proposed development is providing sidewalk connections to Richmond Road
- The multimodal level of service analysis outline failing levels of service for pedestrian and cyclists on the boundary road network. This is primarily a result of large cross-sections and high operating speeds. Major works will be required along Carling Avenue to improve the levels of service;
- The vehicular level of service operates similarly in all analysis periods and horizons, showing that the proposed development has minimal impact on the surrounding neighbourhood;
- The safety review identifies a potential issue with eastbound left turning vehicles on Carling Avenue. These movements should continue to be monitored by the City for potential improvements.

## Appendix A – TIA Screening Form

## City of Ottawa 2017 TIA Guidelines Screening Form

### 1. Description of Proposed Development

Municipal Address	1420 Richmond Rd, 365 Forest St & 2583-2589 Bond St
Description of Location	Mixed-Use (commercial 3555 m <sup>2</sup> , residential 223 units)
Land Use Classification	AM10
Development Size (units)	223 Units
Development Size (m <sup>2</sup> )	3555
Number of Accesses and Locations	1 main entrance - Bond St.
Phase of Development	Site Plan Approval
Buildout Year	2019-2020

**If available, please attach a sketch of the development or site plan to this form.**

### 2. Trip Generation Trigger

Considering the Development's Land Use type and Size (as filled out in the previous section), please refer to the Trip Generation Trigger checks below.

Land Use Type	Minimum Development Size
Single-family homes	40 units
Townhomes or apartments	90 units < 228
Office	3,500 m <sup>2</sup>
Industrial	5,000 m <sup>2</sup>
Fast-food restaurant or coffee shop	100 m <sup>2</sup>
Destination retail	1,000 m <sup>2</sup>
Gas station or convenience market	75 m <sup>2</sup>

*\* If the development has a land use type other than what is presented in the table above, estimates of person-trip generation may be made based on average trip generation characteristics represented in the current edition of the Institute of Transportation Engineers (ITE) Trip Generation Manual.*

**If the proposed development size is greater than the sizes identified above, the Trip Generation Trigger is satisfied.**

### 3. Location Triggers

	Yes	No
Does the development propose a new driveway to a boundary street that is designated as part of the City's Transit Priority, Rapid Transit or Spine Bicycle Networks?		X
Is the development in a Design Priority Area (DPA) or Transit-oriented Development (TOD) zone?*	X	

\*DPA and TOD are identified in the City of Ottawa Official Plan (DPA in Section 2.5.1 and Schedules A and B; TOD in Annex 6). See Chapter 4 for a list of City of Ottawa Planning and Engineering documents that support the completion of TIA).

**If any of the above questions were answered with 'Yes,' the Location Trigger is satisfied.**

### 4. Safety Triggers

	Yes	No
Are posted speed limits on a boundary street are 80 km/hr or greater?		X
Are there any horizontal/vertical curvatures on a boundary street limits sight lines at a proposed driveway?		X
Is the proposed driveway within the area of influence of an adjacent traffic signal or roundabout (i.e. within 300 m of intersection in rural conditions, or within 150 m of intersection in urban/ suburban conditions)?	X	
Is the proposed driveway within auxiliary lanes of an intersection?		X
Does the proposed driveway make use of an existing median break that serves an existing site?		X
Is there is a documented history of traffic operations or safety concerns on the boundary streets within 500 m of the development?		X
Does the development include a drive-thru facility?		X

**If any of the above questions were answered with 'Yes,' the Safety Trigger is satisfied.**

### 5. Summary

	Yes	No
Does the development satisfy the Trip Generation Trigger?	X	
Does the development satisfy the Location Trigger?	X	
Does the development satisfy the Safety Trigger?	X	

**If none of the triggers are satisfied, the TIA Study is complete. If one or more of the triggers is satisfied, the TIA Study must continue into the next stage (Screening and Scoping).**



## Appendix B – Site Plan



## Appendix C – Traffic and Collision Data



# Transportation Services - Traffic Services

## Turning Movement Count - Full Study Peak Hour Diagram

### CARLING AVE @ CROYDON AVE

**Survey Date:** Thursday, August 25, 2016

**Start Time:** 07:00

**WO No:** 36243

**Device:** Miovision

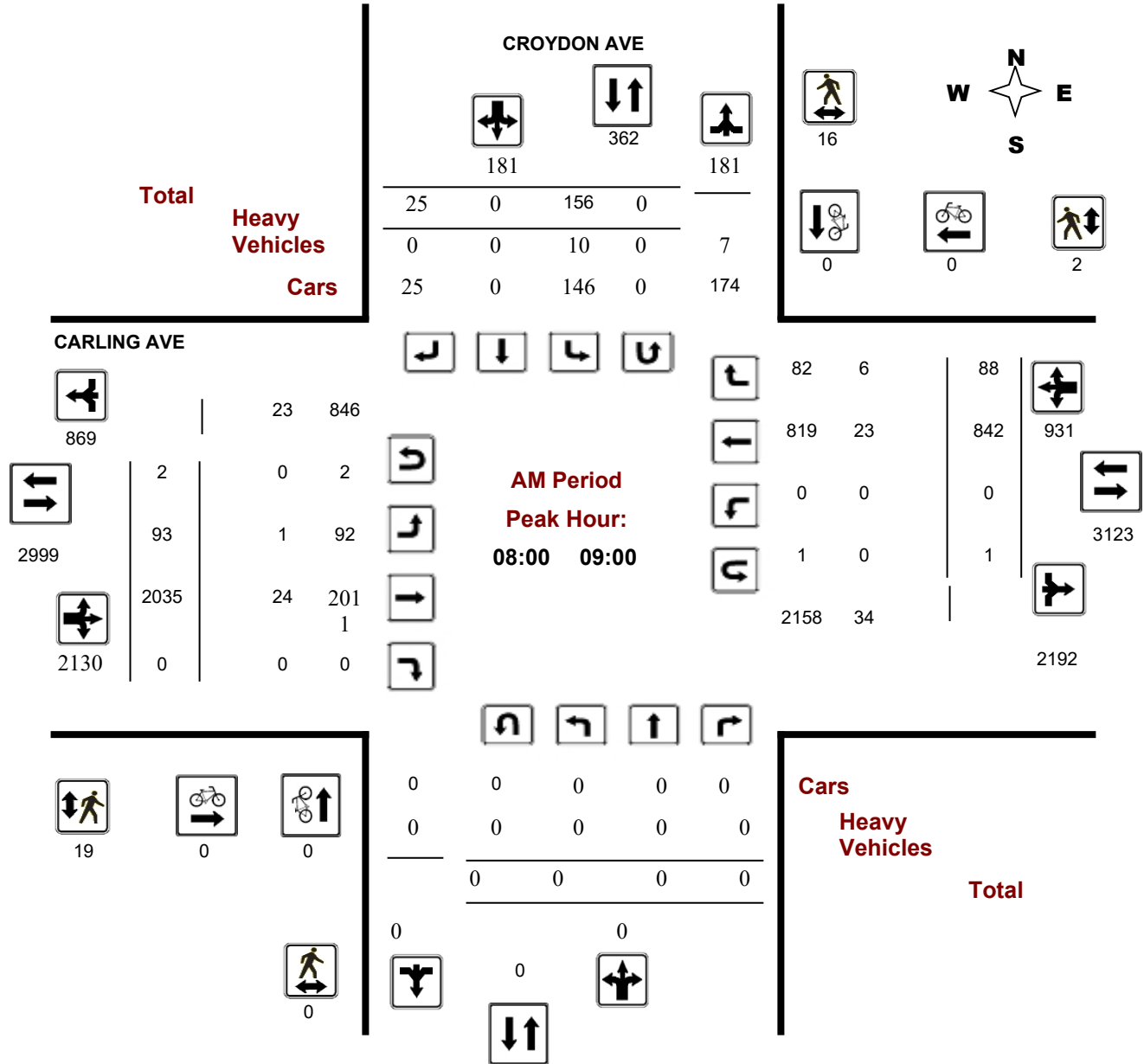

**Survey Date:** Thursday, August 25, 2016

**Start Time:** 07:00

**WO No:** 36243

**Device:** Miovision

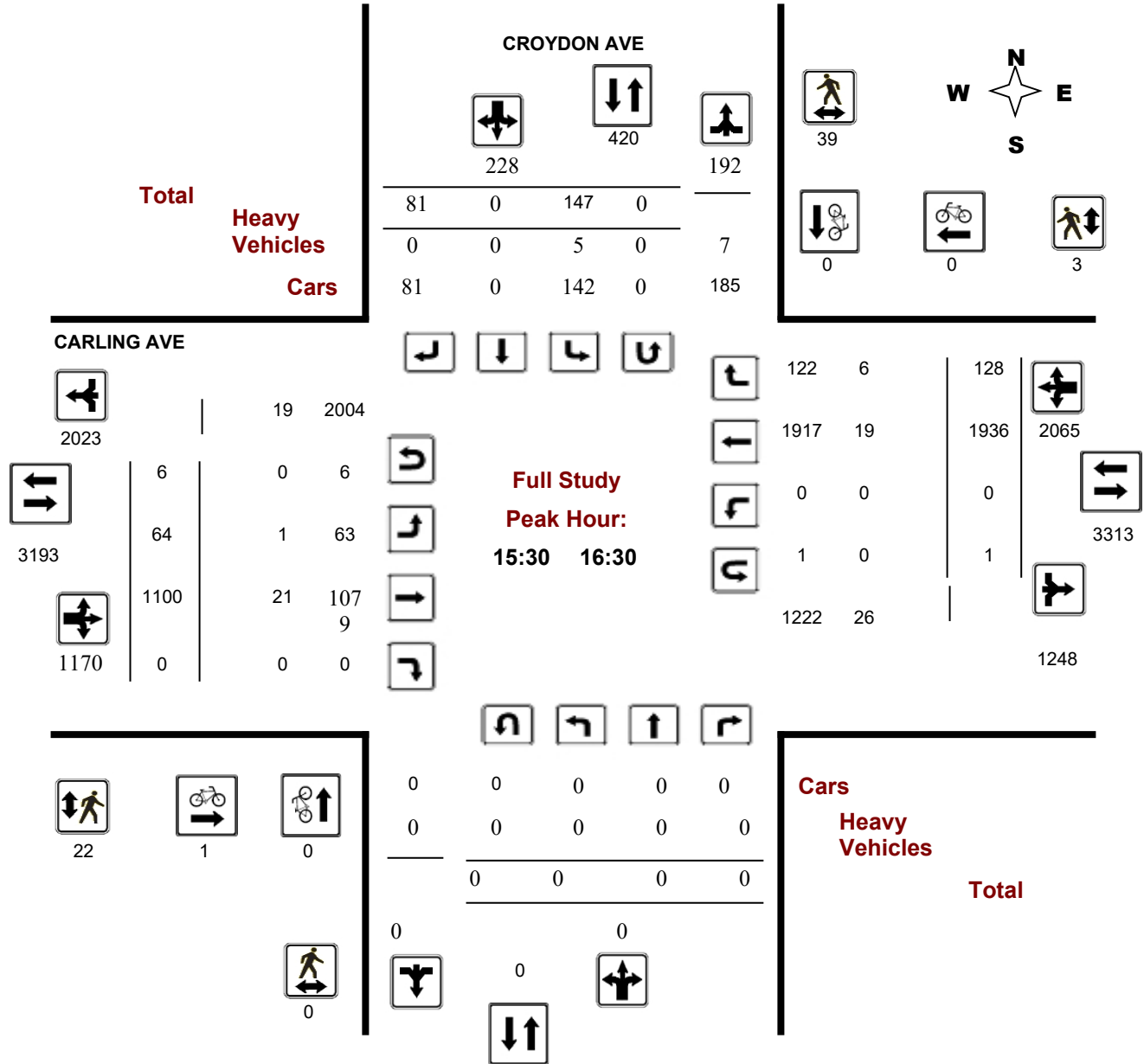

**Comments**

**Survey Date:** Thursday, August 25, 2016

**Start Time:** 07:00

**WO No:** 36243

**Device:** Miovision

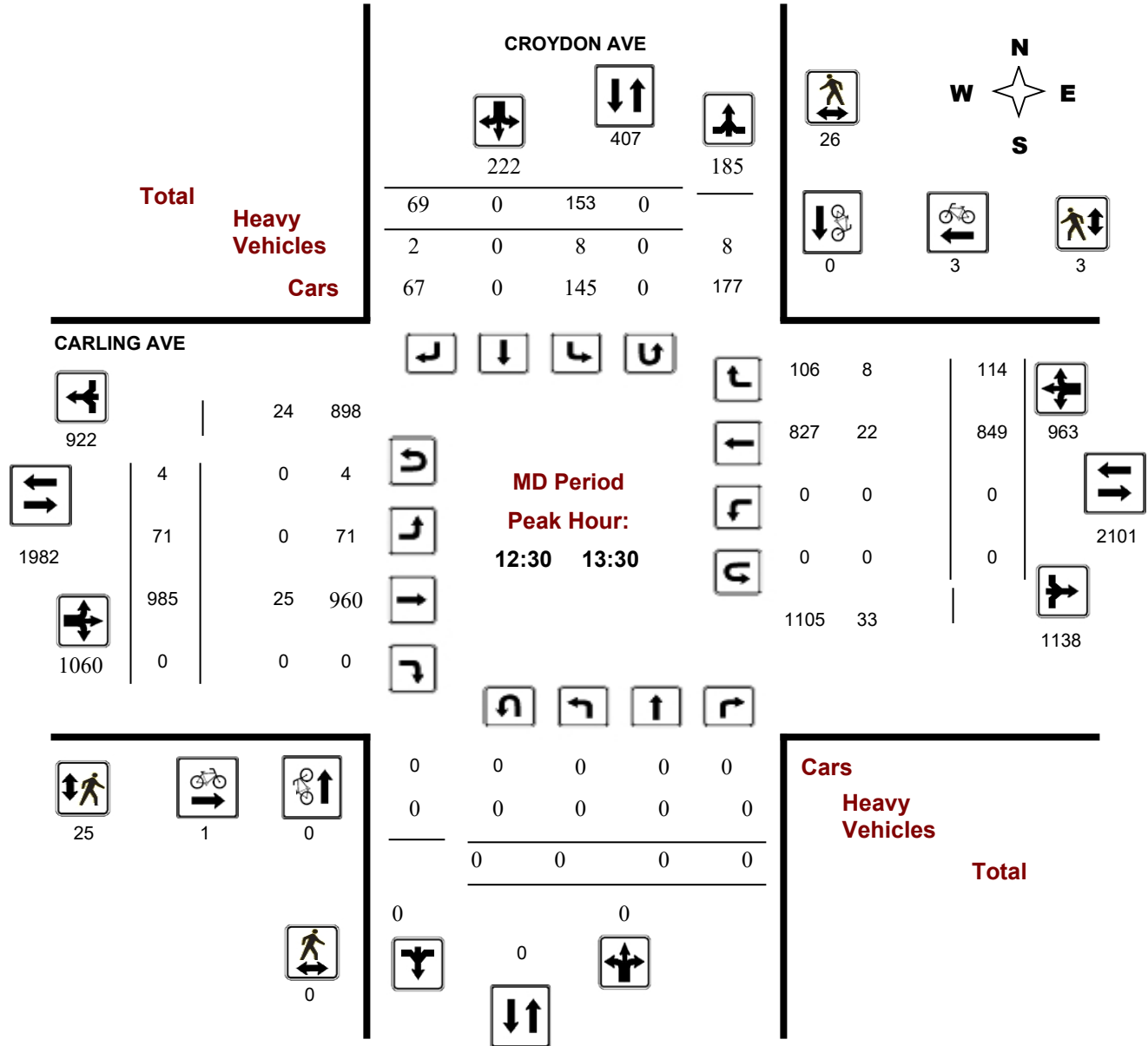

**Survey Date:** Thursday, August 25, 2016

**Start Time:** 07:00

**WO No:** 36243

**Device:** Miovision

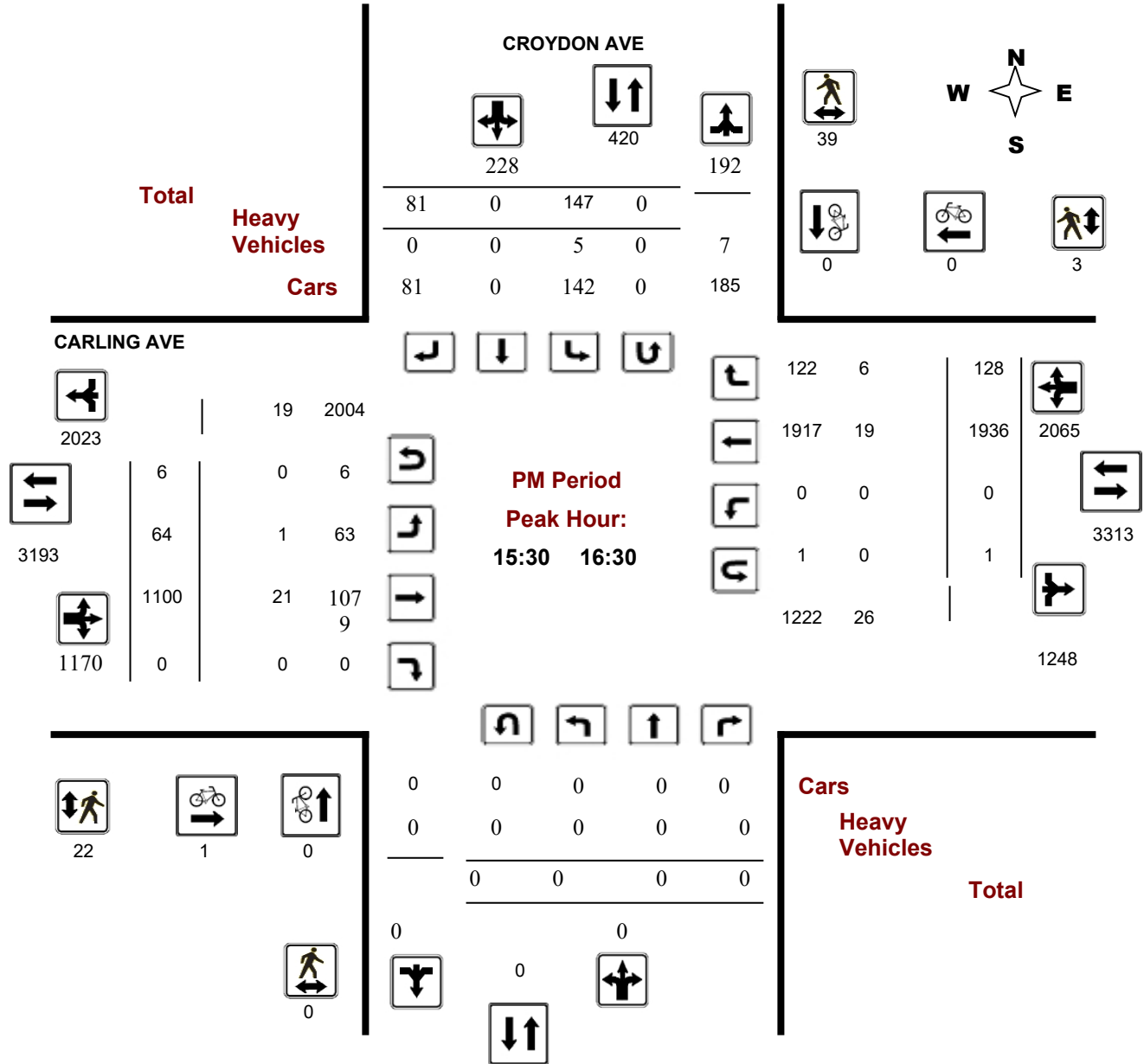

# Transportation Services - Traffic Services

## Turning Movement Count - Full Study Diagram

### CARLING AVE @ CROYDON AVE

**Survey Date:** Thursday, August 25, 2016

**WO#:** 36243  
**Device:** Miovision

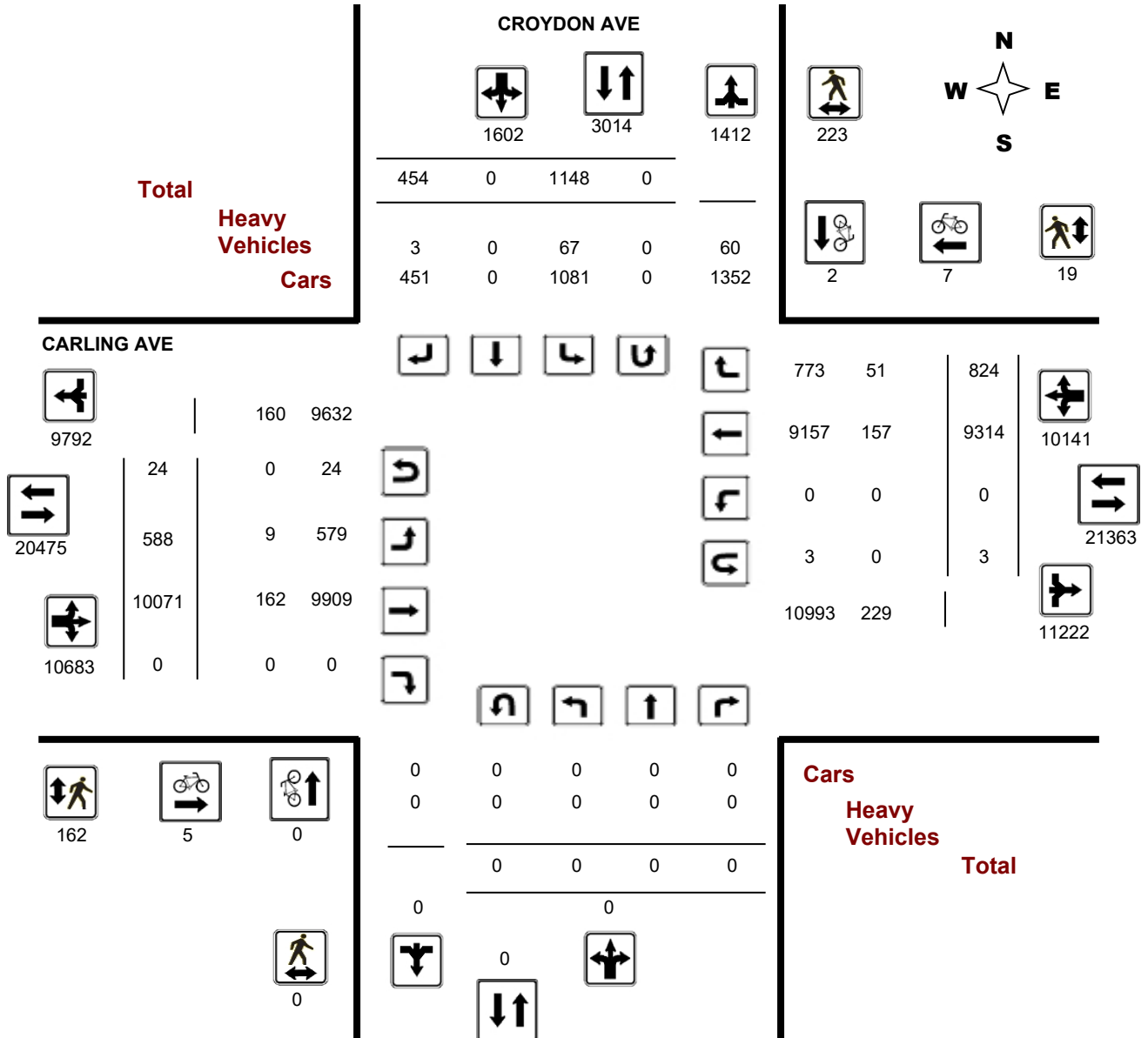

**Comments**





Turning Movement Count - Full Study Summary Report

CARLING AVE @ CROYDON AVE

Survey Date: Thursday, August 25, 2016

Total Observed U-Turns

Northbound: 0 Southbound: 0  
Eastbound: 24 Westbound: 3

AADT Factor

.90

Full Study

Period	CROYDON AVE								CARLING AVE								STR TOT	Grand Total	
	Northbound				Southbound				Eastbound				Westbound						
	LT	ST	RT	NB TOT	LT	ST	RT	SB TOT	LT	ST	RT	EB TOT	LT	ST	RT	WB TOT			
07:00 08:00	0	0	0	0	109	0	15	124	124	69	1911	0	1980	0	675	50	725	2705	2829
08:00 09:00	0	0	0	0	156	0	25	181	181	93	2035	0	2128	0	842	88	930	3058	3239
09:00 10:00	0	0	0	0	155	0	48	203	203	65	1063	0	1128	0	751	93	844	1972	2175
11:30 12:30	0	0	0	0	141	0	66	207	207	82	765	0	847	0	800	111	911	1758	1965
12:30 13:30	0	0	0	0	153	0	69	222	222	71	985	0	1056	0	849	114	963	2019	2241
15:00 16:00	0	0	0	0	136	0	75	211	211	69	1056	0	1125	0	1716	124	1840	2965	3176
16:00 17:00	0	0	0	0	145	0	78	223	223	73	1101	0	1174	0	1893	116	2009	3183	3406
17:00 18:00	0	0	0	0	153	0	78	231	231	66	1155	0	1221	0	1788	128	1916	3137	3368
<b>Sub Total</b>	0	0	0	0	1148	0	454	1602	1602	588	10071	0	10659	0	9314	824	10138	20797	22399
<b>U Turns</b>				0				0	0				24				3	27	27
<b>Total</b>	0	0	0	0	1148	0	454	1602	1602	588	10071	0	10683	0	9314	824	10141	20824	22426
<b>EQ 12Hr</b>	0	0	0	0	1596	0	631	2227	2227	817	13999	0	14849	0	12946	1145	14096	28945	31172
Note: These values are calculated by multiplying the totals by the appropriate expansion factor.																	<b>1.39</b>		
<b>AVG 12Hr</b>	0	0	0	0	1436	0	568	2004	2004	736	12599	0	13364	0	11652	1031	12686	26050	28054
Note: These volumes are calculated by multiplying the Equivalent 12 hr. totals by the AADT factor.																	<b>.90</b>		
<b>AVG 24Hr</b>	0	0	0	0	1881	0	744	2625	2625	964	16504	0	17507	0	15264	1350	16619	34126	36751
Note: These volumes are calculated by multiplying the Average Daily 12 hr. totals by 12 to 24 expansion factor.																	<b>1.31</b>		

Comments:

Note: U-Turns provided for approach totals. Refer to 'U-Turn' Report for specific breakdown.



# Transportation Services - Traffic Services W.O. 36243

## Turning Movement Count - 15 Minute Summary Report

### CARLING AVE @ CROYDON AVE

**Survey Date:** Thursday, August 25, 2016

**Total Observed U-Turns**

Northbound: 0      Southbound: 0  
 Eastbound: 24      Westbound: 3

Time Period	CROYDON AVE									CARLING AVE									Grand Total
	Northbound			N TOT	Southbound			S TOT	STR TOT	Eastbound			E TOT	Westbound			W TOT	STR TOT	
	LT	ST	RT		LT	ST	RT			LT	ST	RT		LT	ST	RT			
07:00 07:15	0	0	0	0	24	0	3	27	27	11	362	0	374	0	147	6	153	527	554
07:15 07:30	0	0	0	0	19	0	5	24	24	25	457	0	482	0	164	8	172	654	678
07:30 07:45	0	0	0	0	40	0	5	45	45	14	541	0	555	0	188	13	201	756	801
07:45 08:00	0	0	0	0	26	0	2	28	28	19	551	0	570	0	176	23	199	769	797
08:00 08:15	0	0	0	0	43	0	7	50	50	19	502	0	521	0	193	19	212	733	783
08:15 08:30	0	0	0	0	37	0	3	40	40	25	517	0	542	0	198	24	222	764	804
08:30 08:45	0	0	0	0	44	0	4	48	48	25	522	0	549	0	226	21	248	797	845
08:45 09:00	0	0	0	0	32	0	11	43	43	24	494	0	518	0	225	24	249	767	810
09:00 09:15	0	0	0	0	46	0	6	52	52	16	329	0	348	0	219	26	245	593	645
09:15 09:30	0	0	0	0	27	0	12	39	39	20	312	0	334	0	175	19	194	528	567
09:30 09:45	0	0	0	0	40	0	17	57	57	12	232	0	245	0	184	27	211	456	513
09:45 10:00	0	0	0	0	42	0	13	55	55	17	190	0	208	0	173	21	194	402	457
11:30 11:45	0	0	0	0	39	0	14	53	53	20	173	0	194	0	188	19	207	401	454
11:45 12:00	0	0	0	0	40	0	18	58	58	18	186	0	206	0	208	27	235	441	499
12:00 12:15	0	0	0	0	25	0	18	43	43	23	201	0	224	0	204	31	235	459	502
12:15 12:30	0	0	0	0	37	0	16	53	53	21	205	0	226	0	200	34	234	460	513
12:30 12:45	0	0	0	0	43	0	18	61	61	13	211	0	224	0	213	23	236	460	521
12:45 13:00	0	0	0	0	46	0	19	65	65	16	227	0	243	0	227	28	255	498	563
13:00 13:15	0	0	0	0	31	0	17	48	48	20	274	0	295	0	197	30	227	522	570
13:15 13:30	0	0	0	0	33	0	15	48	48	22	273	0	298	0	212	33	245	543	591
15:00 15:15	0	0	0	0	29	0	9	38	38	13	259	0	272	0	346	27	374	646	684
15:15 15:30	0	0	0	0	43	0	22	65	65	20	264	0	284	0	405	31	436	720	785
15:30 15:45	0	0	0	0	31	0	18	49	49	16	276	0	293	0	491	27	519	812	861
15:45 16:00	0	0	0	0	33	0	26	59	59	20	257	0	278	0	474	39	513	791	850
16:00 16:15	0	0	0	0	37	0	19	56	56	14	263	0	281	0	484	36	520	801	857
16:15 16:30	0	0	0	0	46	0	18	64	64	14	304	0	318	0	487	26	513	831	895
16:30 16:45	0	0	0	0	34	0	15	49	49	22	273	0	295	0	459	28	487	782	831
16:45 17:00	0	0	0	0	28	0	26	54	54	23	261	0	284	0	463	26	489	773	827
17:00 17:15	0	0	0	0	44	0	22	66	66	20	270	0	290	0	431	22	453	743	809
17:15 17:30	0	0	0	0	37	0	22	59	59	15	302	0	317	0	450	34	484	801	860
17:30 17:45	0	0	0	0	43	0	18	61	61	17	307	0	325	0	474	39	513	838	899
17:45 18:00	0	0	0	0	29	0	16	45	45	14	276	0	290	0	433	33	466	756	801
<b>TOTAL:</b>	<b>0</b>	<b>0</b>	<b>0</b>	<b>0</b>	<b>1148</b>	<b>0</b>	<b>454</b>	<b>1602</b>	<b>1602</b>	<b>588</b>	<b>10071</b>	<b>0</b>	<b>10683</b>	<b>0</b>	<b>9314</b>	<b>824</b>	<b>10141</b>	<b>20824</b>	<b>22426</b>

Note: U-Turns are included in Totals.

**Comment:**



# Transportation Services - Traffic Services

## Turning Movement Count - Cyclist Volume Report

**Work Order**  
**36243**

### CARLING AVE @ CROYDON AVE

**Count Date:** Thursday, August 25, 2016

**Start Time:** 07:00

Time Period	CROYDON AVE			CARLING AVE			Grand Total
	Northbound	Southbound	Street Total	Eastbound	Westbound	Street Total	
07:00 08:00	0	1	1	0	0	0	1
08:00 09:00	0	0	0	0	0	0	0
09:00 10:00	0	0	0	1	2	3	3
11:30 12:30	0	0	0	0	0	0	0
12:30 13:30	0	0	0	1	3	4	4
15:00 16:00	0	0	0	1	0	1	1
16:00 17:00	0	1	1	0	0	0	1
17:00 18:00	0	0	0	2	2	4	4
<b>Total .....</b>	<b>0</b>	<b>2</b>	<b>2</b>	<b>5</b>	<b>7</b>	<b>12</b>	<b>14</b>

**Comment:**

Note: These volumes consists of bicycles only (no mopeds or motorcycles) and ARE NOT included in the Turning Movement Count Summary.



# Transportation Services - Traffic Services

W.O.  
36243

## Turning Movement Count - Heavy Vehicle Report

### CARLING AVE @ CROYDON AVE

**Survey Date:** Thursday, August 25, 2016

Time Period	CROYDON AVE									CARLING AVE									Grand Total
	Northbound			N TOT	Southbound			S TOT	STR TOT	Eastbound			E TOT	Westbound			W TOT	STR TOT	
	LT	ST	RT		LT	ST	RT			LT	ST	RT		LT	ST	RT			
07:00 08:00	0	0	0	0	6	0	0	6	6	2	23	0	25	0	20	3	23	48	54
08:00 09:00	0	0	0	0	10	0	0	10	10	1	24	0	25	0	23	6	29	54	64
09:00 10:00	0	0	0	0	9	0	0	9	9	2	27	0	29	0	22	6	28	57	66
11:30 12:30	0	0	0	0	11	0	0	11	11	2	16	0	18	0	18	10	28	46	57
12:30 13:30	0	0	0	0	8	0	2	10	10	0	25	0	25	0	22	8	30	55	65
15:00 16:00	0	0	0	0	9	0	0	9	9	0	18	0	18	0	19	5	24	42	51
16:00 17:00	0	0	0	0	7	0	0	7	7	1	17	0	18	0	16	7	23	41	48
17:00 18:00	0	0	0	0	7	0	1	8	8	1	12	0	13	0	17	6	23	36	44
<b>Sub Total</b>	<b>0</b>	<b>0</b>	<b>0</b>	<b>0</b>	<b>67</b>	<b>0</b>	<b>3</b>	<b>70</b>	<b>70</b>	<b>9</b>	<b>162</b>	<b>0</b>	<b>171</b>	<b>0</b>	<b>157</b>	<b>51</b>	<b>208</b>	<b>379</b>	<b>449</b>
<b>U-Turns (Heavy Vehicles)</b>				<b>0</b>				<b>0</b>	<b>0</b>				<b>0</b>				<b>0</b>	<b>0</b>	<b>0</b>
<b>Total</b>	<b>0</b>	<b>0</b>	<b>0</b>	<b>0</b>	<b>67</b>	<b>0</b>	<b>3</b>	<b>70</b>	<b>70</b>	<b>9</b>	<b>162</b>	<b>0</b>	<b>171</b>	<b>0</b>	<b>157</b>	<b>51</b>	<b>208</b>	<b>379</b>	<b>449</b>

Heavy Vehicles include Buses, Single-Unit Trucks and Articulated Trucks. Further, they ARE included in the Turning Movement Count Summary.



# Transportation Services - Traffic Services

Work Order

36243

## Turning Movement Count - Pedestrian Volume Report

### CARLING AVE @ CROYDON AVE

Count Date: Thursday, August 25, 2016

Start Time: 07:00

Time Period	NB Approach (E or W Crossing)	SB Approach (E or W Crossing)	Total	EB Approach (N or S Crossing)	WB Approach (N or S Crossing)	Total	Grand Total
07:00 07:15	0	1	1	4	0	4	5
07:15 07:30	0	3	3	1	0	1	4
07:30 07:45	0	4	4	5	0	5	9
07:45 08:00	0	1	1	2	0	2	3
<b>07:00 08:00</b>	<b>0</b>	<b>9</b>	<b>9</b>	<b>12</b>	<b>0</b>	<b>12</b>	<b>21</b>
08:00 08:15	0	0	0	6	0	6	6
08:15 08:30	0	3	3	3	0	3	6
08:30 08:45	0	9	9	6	0	6	15
08:45 09:00	0	4	4	4	2	6	10
<b>08:00 09:00</b>	<b>0</b>	<b>16</b>	<b>16</b>	<b>19</b>	<b>2</b>	<b>21</b>	<b>37</b>
09:00 09:15	0	5	5	3	0	3	8
09:15 09:30	0	10	10	4	0	4	14
09:30 09:45	0	8	8	1	0	1	9
09:45 10:00	0	8	8	3	1	4	12
<b>09:00 10:00</b>	<b>0</b>	<b>31</b>	<b>31</b>	<b>11</b>	<b>1</b>	<b>12</b>	<b>43</b>
11:30 11:45	0	1	1	4	0	4	5
11:45 12:00	0	12	12	7	1	8	20
12:00 12:15	0	2	2	3	0	3	5
12:15 12:30	0	5	5	6	1	7	12
<b>11:30 12:30</b>	<b>0</b>	<b>20</b>	<b>20</b>	<b>20</b>	<b>2</b>	<b>22</b>	<b>42</b>
12:30 12:45	0	7	7	8	2	10	17
12:45 13:00	0	9	9	9	1	10	19
13:00 13:15	0	5	5	4	0	4	9
13:15 13:30	0	5	5	4	0	4	9
<b>12:30 13:30</b>	<b>0</b>	<b>26</b>	<b>26</b>	<b>25</b>	<b>3</b>	<b>28</b>	<b>54</b>
15:00 15:15	0	5	5	2	5	7	12
15:15 15:30	0	3	3	3	0	3	6
15:30 15:45	0	8	8	4	0	4	12
15:45 16:00	0	9	9	9	2	11	20
<b>15:00 16:00</b>	<b>0</b>	<b>25</b>	<b>25</b>	<b>18</b>	<b>7</b>	<b>25</b>	<b>50</b>
16:00 16:15	0	9	9	3	1	4	13
16:15 16:30	0	13	13	6	0	6	19
16:30 16:45	0	11	11	7	0	7	18
16:45 17:00	0	17	17	4	1	5	22
<b>16:00 17:00</b>	<b>0</b>	<b>50</b>	<b>50</b>	<b>20</b>	<b>2</b>	<b>22</b>	<b>72</b>
17:00 17:15	0	10	10	6	0	6	16
17:15 17:30	0	16	16	7	0	7	23
17:30 17:45	0	12	12	14	2	16	28
17:45 18:00	0	8	8	10	0	10	18
<b>17:00 18:00</b>	<b>0</b>	<b>46</b>	<b>46</b>	<b>37</b>	<b>2</b>	<b>39</b>	<b>85</b>
<b>Total</b> .....	<b>0</b>	<b>223</b>	<b>223</b>	<b>162</b>	<b>19</b>	<b>181</b>	<b>404</b>

Comment:

## Turning Movement Count - 15 Min U-Turn Total Report

### CARLING AVE @ CROYDON AVE

**Survey Date:** Thursday, August 25, 2016

Time Period		Northbound U-Turn Total	Southbound U-Turn Total	Eastbound U-Turn Total	Westbound U-Turn Total	Total
07:00	07:15	0	0	1	0	1
07:15	07:30	0	0	0	0	0
07:30	07:45	0	0	0	0	0
07:45	08:00	0	0	0	0	0
08:00	08:15	0	0	0	0	0
08:15	08:30	0	0	0	0	0
08:30	08:45	0	0	2	1	3
08:45	09:00	0	0	0	0	0
09:00	09:15	0	0	3	0	3
09:15	09:30	0	0	2	0	2
09:30	09:45	0	0	1	0	1
09:45	10:00	0	0	1	0	1
11:30	11:45	0	0	1	0	1
11:45	12:00	0	0	2	0	2
12:00	12:15	0	0	0	0	0
12:15	12:30	0	0	0	0	0
12:30	12:45	0	0	0	0	0
12:45	13:00	0	0	0	0	0
13:00	13:15	0	0	1	0	1
13:15	13:30	0	0	3	0	3
15:00	15:15	0	0	0	1	1
15:15	15:30	0	0	0	0	0
15:30	15:45	0	0	1	1	2
15:45	16:00	0	0	1	0	1
16:00	16:15	0	0	4	0	4
16:15	16:30	0	0	0	0	0
16:30	16:45	0	0	0	0	0
16:45	17:00	0	0	0	0	0
17:00	17:15	0	0	0	0	0
17:15	17:30	0	0	0	0	0
17:30	17:45	0	0	1	0	1
17:45	18:00	0	0	0	0	0
<b>Total</b>		0	0	24	3	27



# Transportation Services - Traffic Services

## Turning Movement Count - Full Study Peak Hour Diagram

### CROYDON AVE @ RICHMOND RD

**Survey Date:** Thursday, August 11, 2016

**Start Time:** 07:00

**WO No:** 36184

**Device:** Miovision

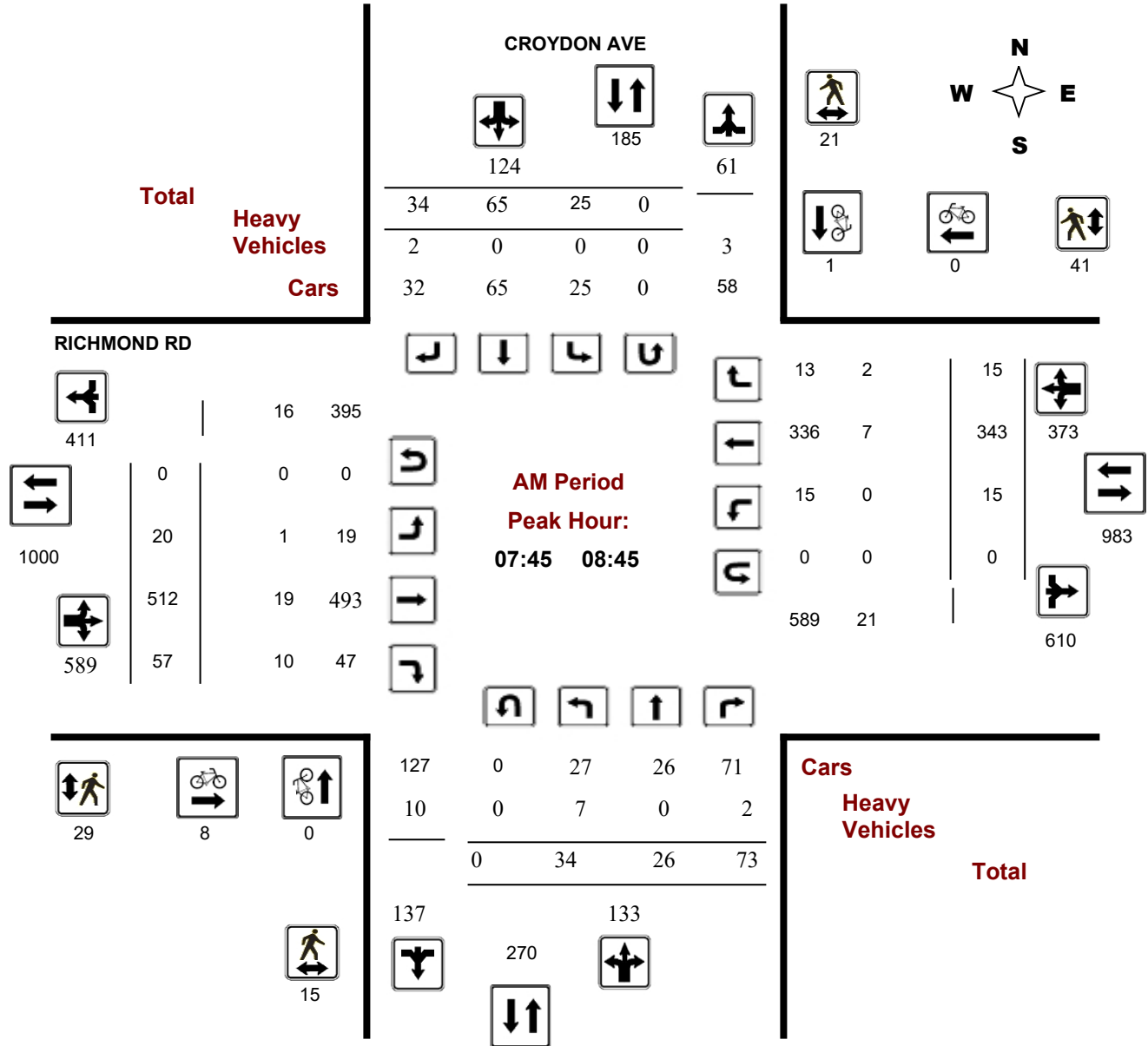

**Survey Date:** Thursday, August 11, 2016

**Start Time:** 07:00

**WO No:** 36184

**Device:** Miovision

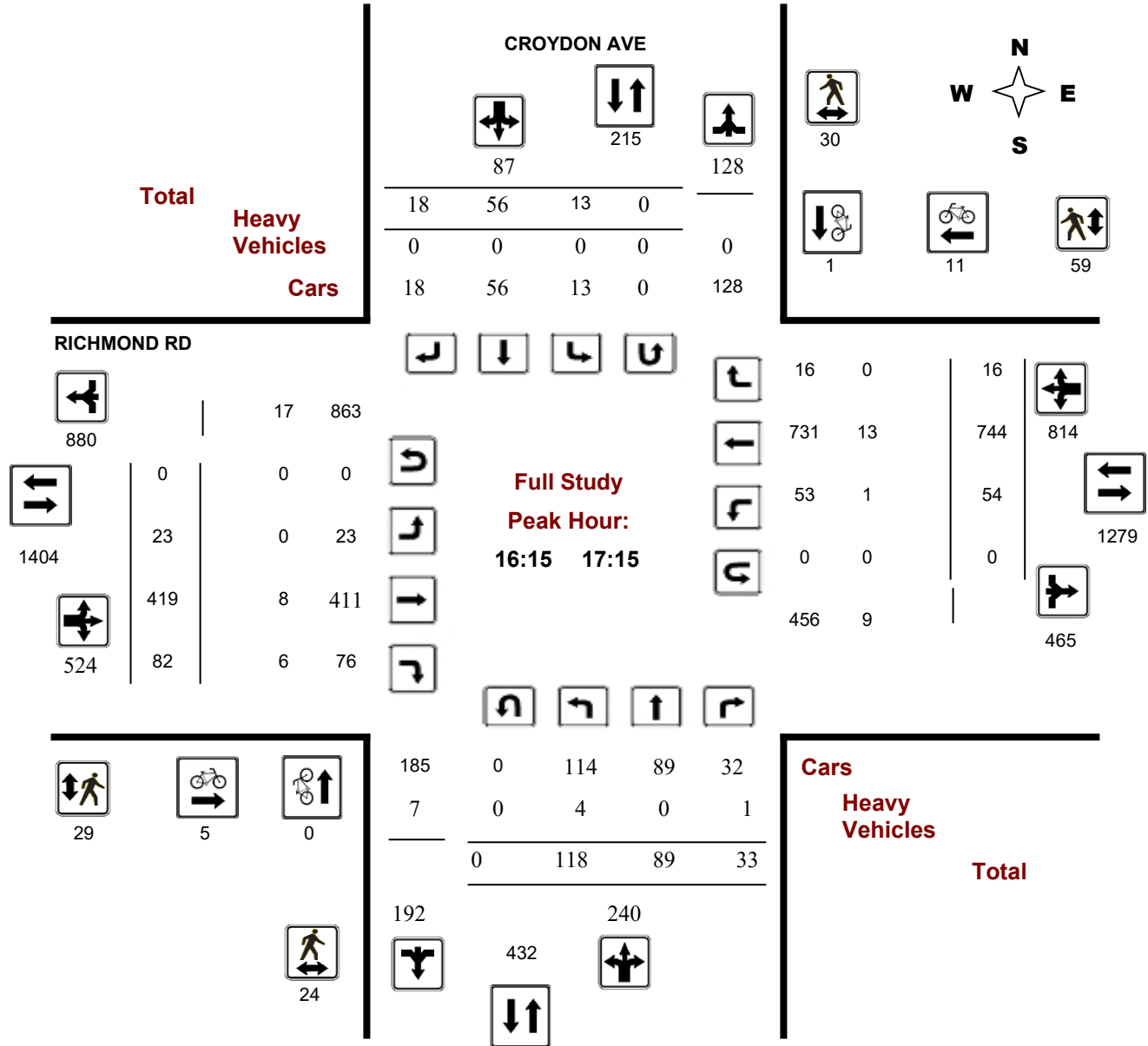

**Comments**



**Survey Date:** Thursday, August 11, 2016

**Start Time:** 07:00

**WO No:** 36184

**Device:** Miovision

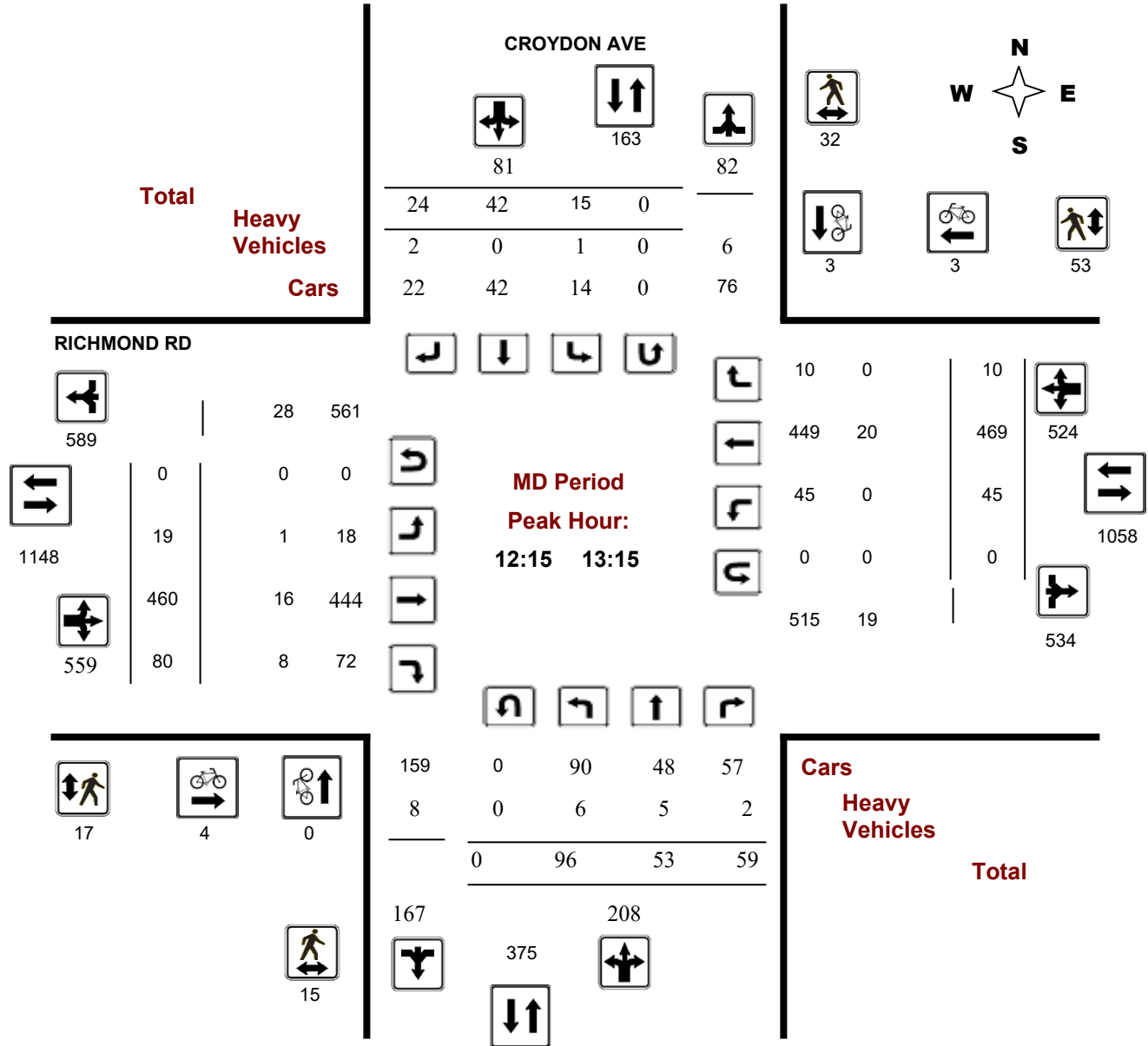

**Survey Date:** Thursday, August 11, 2016

**Start Time:** 07:00

**WO No:** 36184

**Device:** Miovision

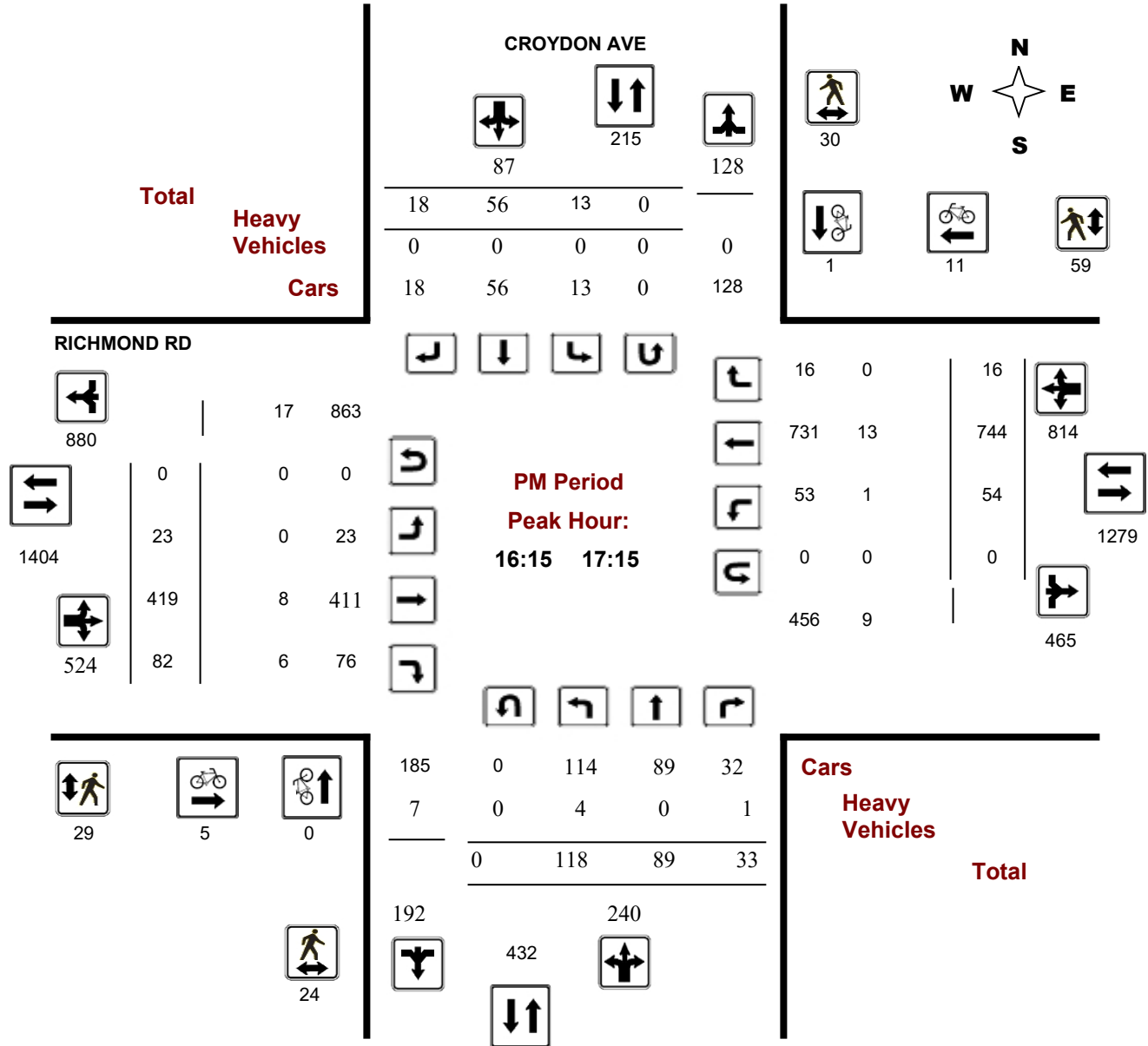

**Comments**

# Transportation Services - Traffic Services

## Turning Movement Count - Full Study Diagram

### CROYDON AVE @ RICHMOND RD

**Survey Date:** Thursday, August 11, 2016

**WO#:** 36184

**Device:** Miovision

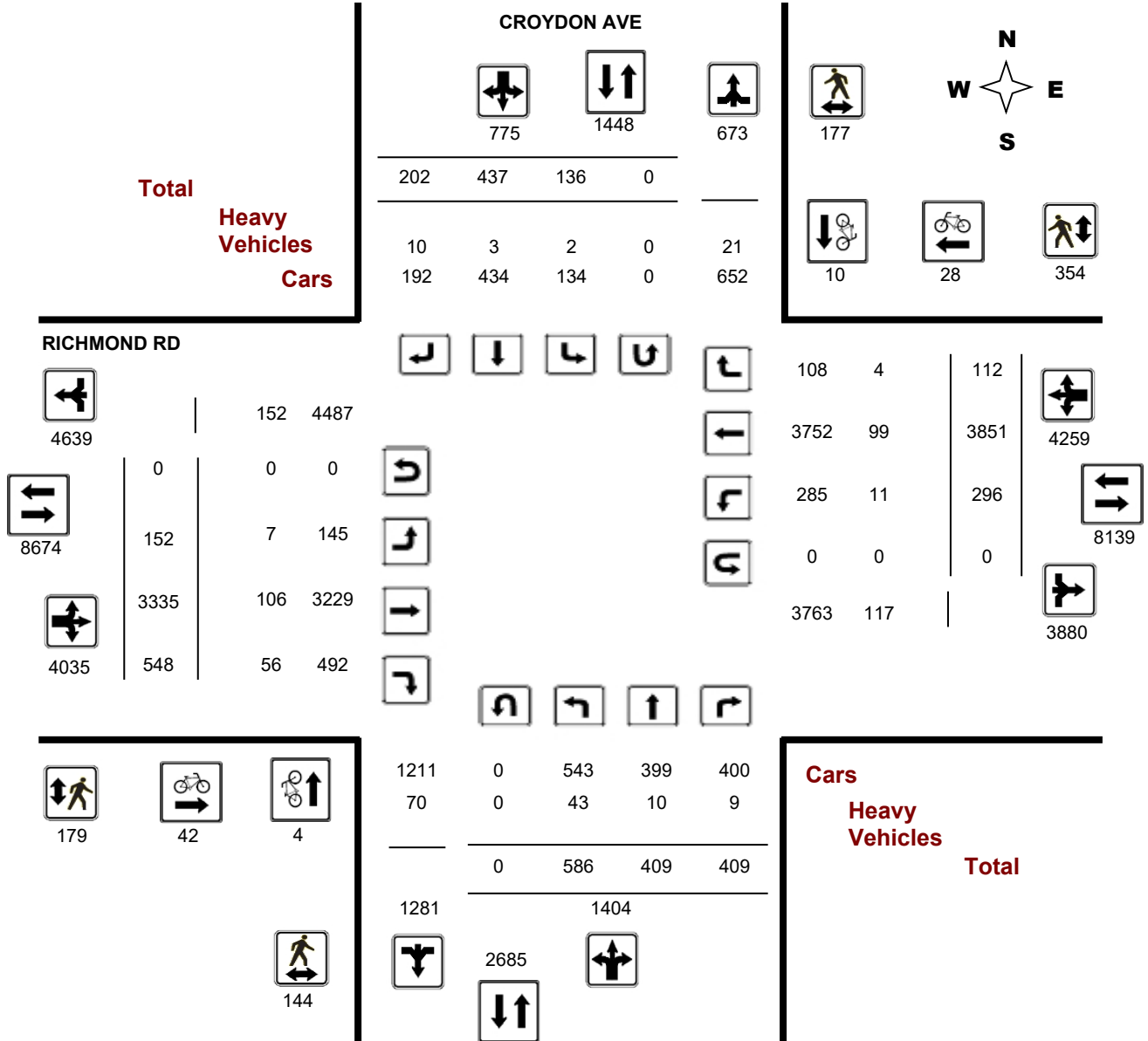

**Comments**

## Turning Movement Count - Full Study Summary Report

### CROYDON AVE @ RICHMOND RD

**Survey Date:** Thursday, August 11, 2016

**Total Observed U-Turns**

Northbound: 0      Southbound: 0  
Eastbound: 0      Westbound: 0

**AADT Factor**

.90

**Full Study**

Period	CROYDON AVE									RICHMOND RD									Grand Total	
	Northbound			NB TOT	Southbound			SB TOT	STR TOT	Eastbound			EB TOT	Westbound			WB TOT	STR TOT		
	LT	ST	RT		LT	ST	RT			LT	ST	RT		LT	ST	RT				
07:00 08:00	25	21	59	105	11	50	18	79	184	19	440	51	510	14	236	7	257	767	951	
08:00 09:00	35	23	68	126	28	69	38	135	261	19	502	54	575	19	345	16	380	955	1216	
09:00 10:00	46	34	48	128	21	61	20	102	230	16	363	65	444	36	353	14	403	847	1077	
11:30 12:30	72	48	46	166	12	56	15	83	249	12	396	73	481	56	439	13	508	989	1238	
12:30 13:30	95	53	63	211	19	33	30	82	293	20	435	79	534	39	456	11	506	1040	1333	
15:00 16:00	93	63	43	199	17	54	30	101	300	20	373	75	468	42	644	24	710	1178	1478	
16:00 17:00	114	72	36	222	16	60	23	99	321	22	419	84	525	47	711	14	772	1297	1618	
17:00 18:00	106	95	46	247	12	54	28	94	341	24	407	67	498	43	667	13	723	1221	1562	
<b>Sub Total</b>	586	409	409	1404	136	437	202	775	2179	152	3335	548	4035	296	3851	112	4259	8294	10473	
<b>U Turns</b>				0				0	0				0				0	0	0	0
<b>Total</b>	586	409	409	1404	136	437	202	775	2179	152	3335	548	4035	296	3851	112	4259	8294	10473	
<b>EQ 12Hr</b>	815	569	569	1952	189	607	281	1077	3029	211	4636	762	5609	411	5353	156	5920	11529	14558	
Note: These values are calculated by multiplying the totals by the appropriate expansion factor.													<b>1.39</b>							
<b>AVG 12Hr</b>	733	512	512	1756	170	547	253	970	2726	190	4172	686	5048	370	4818	140	5328	10376	13102	
Note: These volumes are calculated by multiplying the Equivalent 12 hr. totals by the AADT factor.													<b>.90</b>							
<b>AVG 24Hr</b>	960	670	670	2301	223	716	331	1270	3571	249	5465	898	6613	485	6311	184	6980	13593	17164	
Note: These volumes are calculated by multiplying the Average Daily 12 hr. totals by 12 to 24 expansion factor.													<b>1.31</b>							

**Comments:**

Note: U-Turns provided for approach totals. Refer to 'U-Turn' Report for specific breakdown.



Turning Movement Count - 15 Minute Summary Report

CROYDON AVE @ RICHMOND RD

Survey Date: Thursday, August 11, 2016

Total Observed U-Turns

Northbound: 0 Southbound: 0
Eastbound: 0 Westbound: 0

CROYDON AVE

RICHMOND RD

Table with columns for Time Period, Northbound (LT, ST, RT, N TOT), Southbound (LT, ST, RT, S TOT, STR TOT), Eastbound (LT, ST, RT, E TOT), Westbound (LT, ST, RT, W TOT, STR TOT), and Grand Total. Rows represent 15-minute intervals from 07:00 to 18:00.

Note: U-Turns are included in Totals.

Comment:



# Transportation Services - Traffic Services

## Turning Movement Count - Cyclist Volume Report

**Work Order**  
**36184**

### CROYDON AVE @ RICHMOND RD

**Count Date:** Thursday, August 11, 2016

**Start Time:** 07:00

Time Period	CROYDON AVE			RICHMOND RD			Grand Total
	Northbound	Southbound	Street Total	Eastbound	Westbound	Street Total	
07:00 08:00	1	1	2	5	2	7	9
08:00 09:00	0	0	0	7	0	7	7
09:00 10:00	0	0	0	8	2	10	10
11:30 12:30	0	4	4	2	4	6	10
12:30 13:30	0	1	1	4	1	5	6
15:00 16:00	2	0	2	3	3	6	8
16:00 17:00	0	1	1	8	11	19	20
17:00 18:00	1	3	4	5	5	10	14
<b>Total .....</b>	<b>4</b>	<b>10</b>	<b>14</b>	<b>42</b>	<b>28</b>	<b>70</b>	<b>84</b>

**Comment:**

Note: These volumes consists of bicycles only (no mopeds or motorcycles) and ARE NOT included in the Turning Movement Count Summary.



# Transportation Services - Traffic Services

W.O.  
36184

## Turning Movement Count - Heavy Vehicle Report

### CROYDON AVE @ RICHMOND RD

**Survey Date:** Thursday, August 11, 2016

Time Period	CROYDON AVE									RICHMOND RD									Grand Total
	Northbound			Southbound			S TOT	STR TOT	Eastbound			Westbound			W TOT	STR TOT			
	LT	ST	RT	N TOT	LT	ST			RT	LT	ST	RT	E TOT	LT			ST	RT	
07:00 08:00	8	0	1	9	1	0	1	2	11	1	18	11	30	2	5	1	8	38	49
08:00 09:00	8	0	2	10	0	0	2	2	12	1	19	8	28	0	6	2	8	36	48
09:00 10:00	4	0	0	4	0	0	1	1	5	1	20	11	32	2	17	0	19	51	56
11:30 12:30	4	3	3	10	1	1	1	3	13	1	12	8	21	3	18	0	21	42	55
12:30 13:30	5	4	1	10	0	0	3	3	13	1	14	5	20	1	18	0	19	39	52
15:00 16:00	6	2	1	9	0	2	2	4	13	1	9	3	13	0	11	0	11	24	37
16:00 17:00	4	0	1	5	0	0	0	0	5	1	8	4	13	2	13	0	15	28	33
17:00 18:00	4	1	0	5	0	0	0	0	5	0	6	6	12	1	11	1	13	25	30
<b>Sub Total</b>	<b>43</b>	<b>10</b>	<b>9</b>	<b>62</b>	<b>2</b>	<b>3</b>	<b>10</b>	<b>15</b>	<b>77</b>	<b>7</b>	<b>106</b>	<b>56</b>	<b>169</b>	<b>11</b>	<b>99</b>	<b>4</b>	<b>114</b>	<b>283</b>	<b>360</b>
<b>U-Turns (Heavy Vehicles)</b>				<b>0</b>				<b>0</b>	<b>0</b>				<b>0</b>				<b>0</b>	<b>0</b>	<b>0</b>
<b>Total</b>	<b>43</b>	<b>10</b>	<b>9</b>	<b>0</b>	<b>2</b>	<b>3</b>	<b>10</b>	<b>15</b>	<b>77</b>	<b>7</b>	<b>106</b>	<b>56</b>	<b>169</b>	<b>11</b>	<b>99</b>	<b>4</b>	<b>114</b>	<b>283</b>	<b>360</b>

Heavy Vehicles include Buses, Single-Unit Trucks and Articulated Trucks. Further, they ARE included in the Turning Movement Count Summary.



# Transportation Services - Traffic Services

Work Order

36184

## Turning Movement Count - Pedestrian Volume Report

### CROYDON AVE @ RICHMOND RD

Count Date: Thursday, August 11, 2016

Start Time: 07:00

Time Period	NB Approach (E or W Crossing)	SB Approach (E or W Crossing)	Total	EB Approach (N or S Crossing)	WB Approach (N or S Crossing)	Total	Grand Total
07:00 07:15	3	1	4	4	11	15	19
07:15 07:30	2	1	3	5	4	9	12
07:30 07:45	1	5	6	2	8	10	16
07:45 08:00	3	4	7	8	11	19	26
<b>07:00 08:00</b>	<b>9</b>	<b>11</b>	<b>20</b>	<b>19</b>	<b>34</b>	<b>53</b>	<b>73</b>
08:00 08:15	1	0	1	6	12	18	19
08:15 08:30	5	13	18	8	9	17	35
08:30 08:45	6	4	10	7	9	16	26
08:45 09:00	11	5	16	3	12	15	31
<b>08:00 09:00</b>	<b>23</b>	<b>22</b>	<b>45</b>	<b>24</b>	<b>42</b>	<b>66</b>	<b>111</b>
09:00 09:15	5	1	6	3	11	14	20
09:15 09:30	2	0	2	4	12	16	18
09:30 09:45	1	1	2	5	8	13	15
09:45 10:00	2	4	6	8	16	24	30
<b>09:00 10:00</b>	<b>10</b>	<b>6</b>	<b>16</b>	<b>20</b>	<b>47</b>	<b>67</b>	<b>83</b>
11:30 11:45	6	2	8	3	5	8	16
11:45 12:00	3	4	7	4	6	10	17
12:00 12:15	5	15	20	4	22	26	46
12:15 12:30	6	9	15	4	17	21	36
<b>11:30 12:30</b>	<b>20</b>	<b>30</b>	<b>50</b>	<b>15</b>	<b>50</b>	<b>65</b>	<b>115</b>
12:30 12:45	2	3	5	4	7	11	16
12:45 13:00	4	8	12	2	15	17	29
13:00 13:15	3	12	15	7	14	21	36
13:15 13:30	3	3	6	2	7	9	15
<b>12:30 13:30</b>	<b>12</b>	<b>26</b>	<b>38</b>	<b>15</b>	<b>43</b>	<b>58</b>	<b>96</b>
15:00 15:15	5	4	9	6	7	13	22
15:15 15:30	6	3	9	6	10	16	25
15:30 15:45	3	16	19	10	17	27	46
15:45 16:00	8	5	13	4	10	14	27
<b>15:00 16:00</b>	<b>22</b>	<b>28</b>	<b>50</b>	<b>26</b>	<b>44</b>	<b>70</b>	<b>120</b>
16:00 16:15	9	6	15	13	14	27	42
16:15 16:30	6	9	15	4	21	25	40
16:30 16:45	7	9	16	12	18	30	46
16:45 17:00	9	4	13	5	10	15	28
<b>16:00 17:00</b>	<b>31</b>	<b>28</b>	<b>59</b>	<b>34</b>	<b>63</b>	<b>97</b>	<b>156</b>
17:00 17:15	2	8	10	8	10	18	28
17:15 17:30	5	6	11	7	7	14	25
17:30 17:45	5	8	13	7	9	16	29
17:45 18:00	5	4	9	4	5	9	18
<b>17:00 18:00</b>	<b>17</b>	<b>26</b>	<b>43</b>	<b>26</b>	<b>31</b>	<b>57</b>	<b>100</b>
<b>Total .....</b>	<b>144</b>	<b>177</b>	<b>321</b>	<b>179</b>	<b>354</b>	<b>533</b>	<b>854</b>

Comment:



## Turning Movement Count - 15 Min U-Turn Total Report

### CROYDON AVE @ RICHMOND RD

**Survey Date:** Thursday, August 11, 2016

Time Period		Northbound U-Turn Total	Southbound U-Turn Total	Eastbound U-Turn Total	Westbound U-Turn Total	Total
07:00	07:15	0	0	0	0	0
07:15	07:30	0	0	0	0	0
07:30	07:45	0	0	0	0	0
07:45	08:00	0	0	0	0	0
08:00	08:15	0	0	0	0	0
08:15	08:30	0	0	0	0	0
08:30	08:45	0	0	0	0	0
08:45	09:00	0	0	0	0	0
09:00	09:15	0	0	0	0	0
09:15	09:30	0	0	0	0	0
09:30	09:45	0	0	0	0	0
09:45	10:00	0	0	0	0	0
11:30	11:45	0	0	0	0	0
11:45	12:00	0	0	0	0	0
12:00	12:15	0	0	0	0	0
12:15	12:30	0	0	0	0	0
12:30	12:45	0	0	0	0	0
12:45	13:00	0	0	0	0	0
13:00	13:15	0	0	0	0	0
13:15	13:30	0	0	0	0	0
15:00	15:15	0	0	0	0	0
15:15	15:30	0	0	0	0	0
15:30	15:45	0	0	0	0	0
15:45	16:00	0	0	0	0	0
16:00	16:15	0	0	0	0	0
16:15	16:30	0	0	0	0	0
16:30	16:45	0	0	0	0	0
16:45	17:00	0	0	0	0	0
17:00	17:15	0	0	0	0	0
17:15	17:30	0	0	0	0	0
17:30	17:45	0	0	0	0	0
17:45	18:00	0	0	0	0	0
Total		0	0	0	0	0

**Survey Date:** Wednesday, January 17, 2018

**Start Time:** 07:00

**WO No:** 37422

**Device:** Miovision

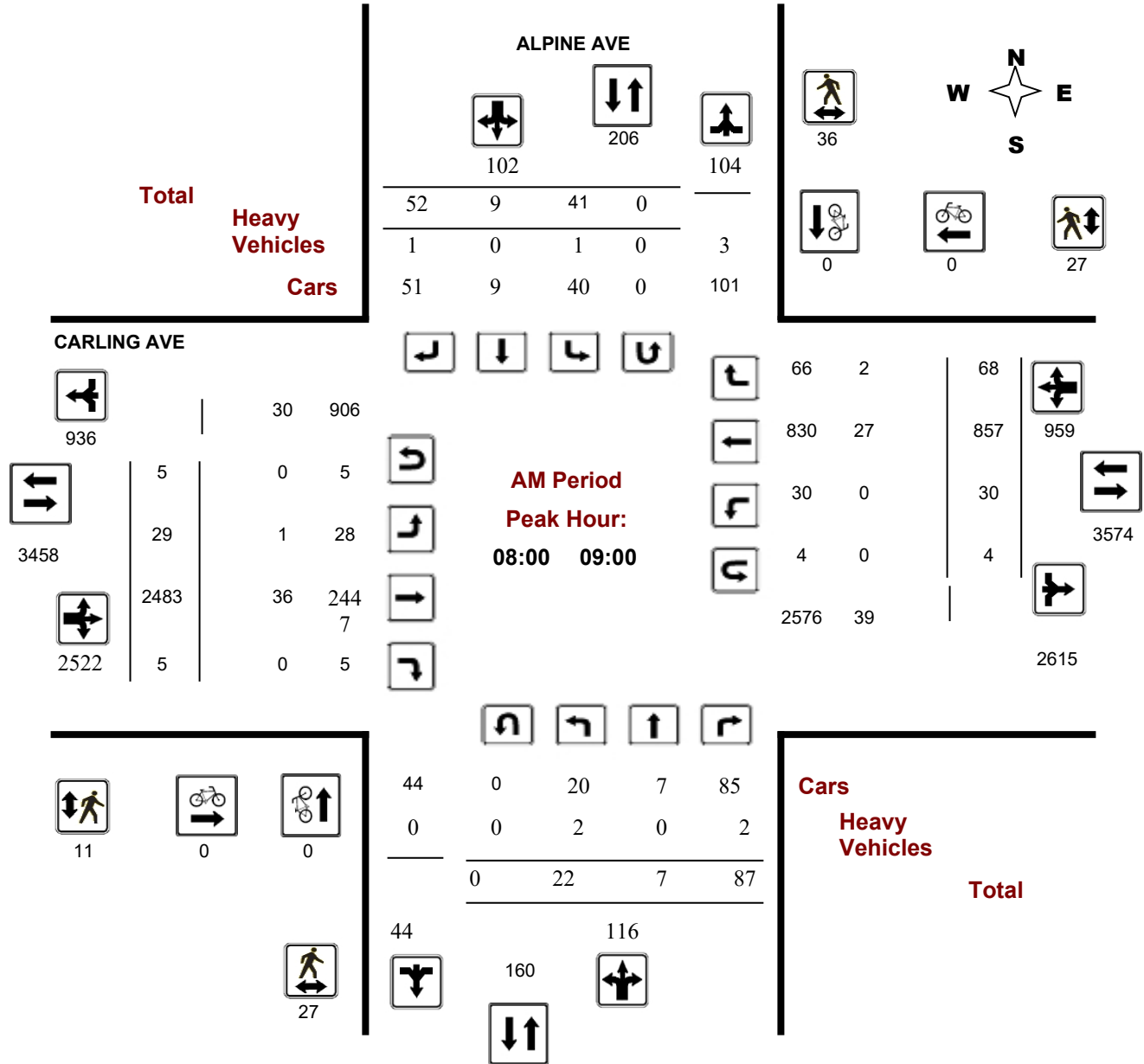

**Survey Date:** Wednesday, January 17, 2018

**Start Time:** 07:00

**WO No:** 37422

**Device:** Miovision

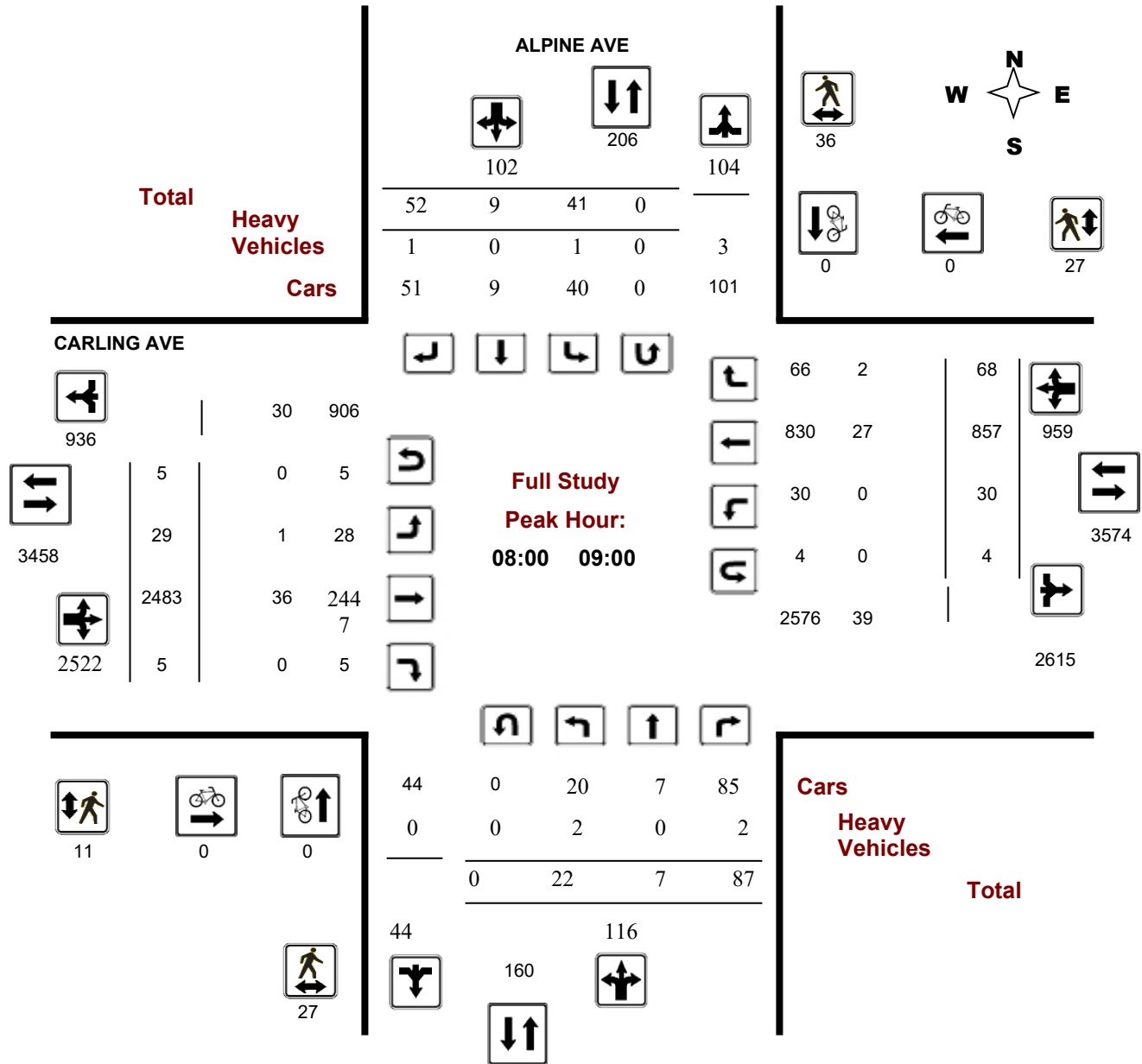

**Survey Date:** Wednesday, January 17, 2018

**Start Time:** 07:00

**WO No:** 37422

**Device:** Miovision

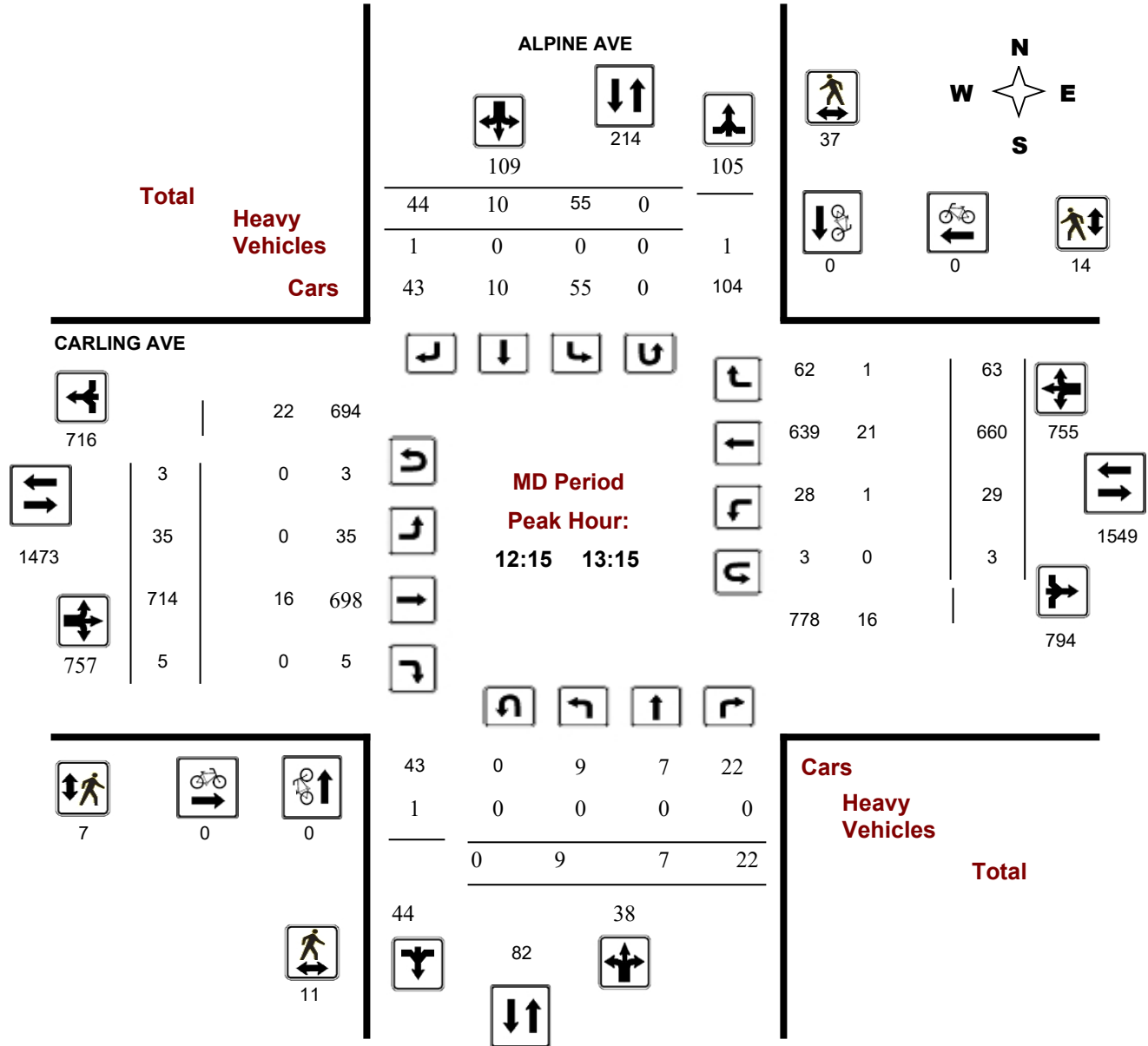

**Survey Date:** Wednesday, January 17, 2018

**Start Time:** 07:00

**WO No:** 37422

**Device:** Miovision

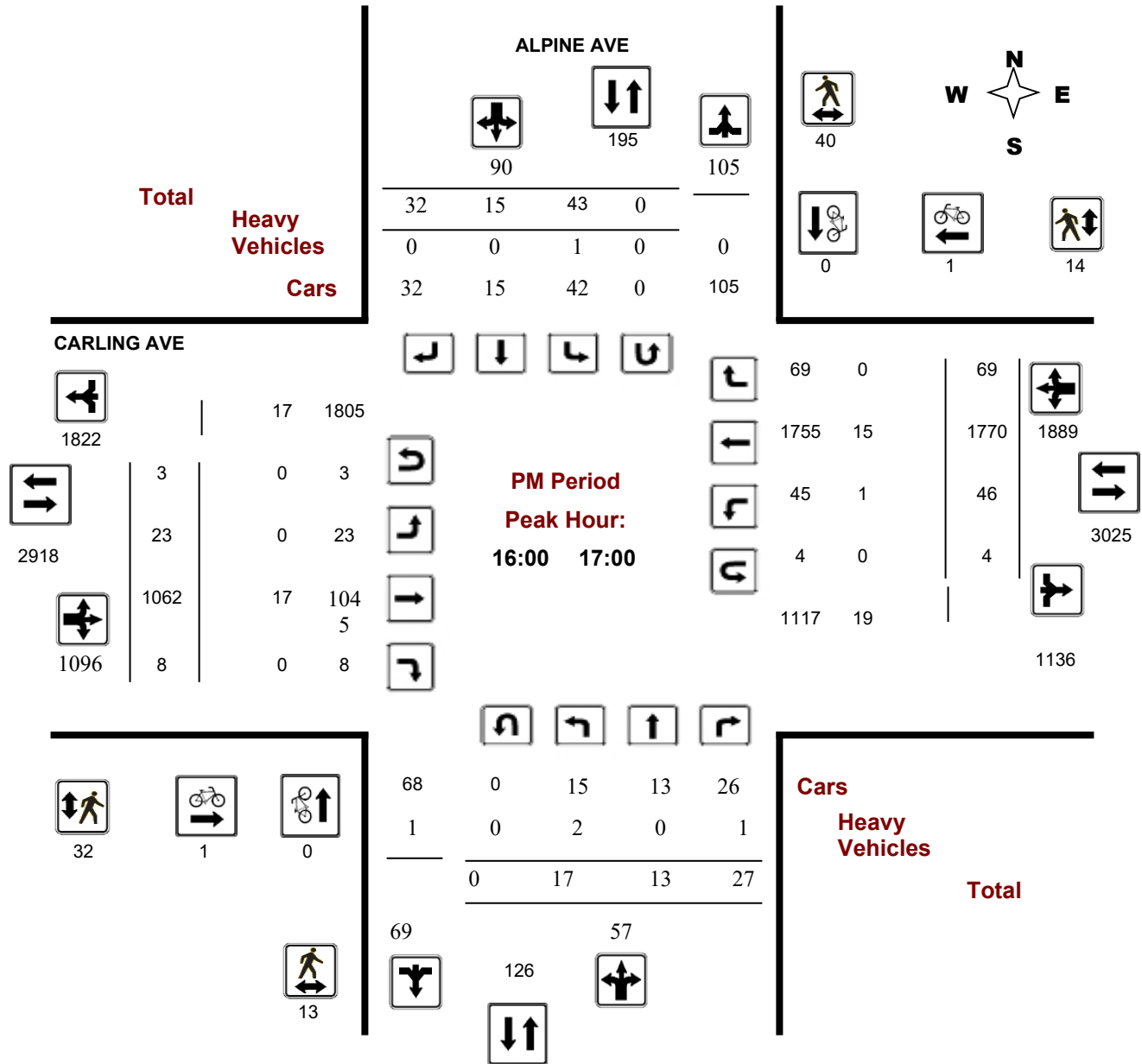

# Transportation Services - Traffic Services

## Turning Movement Count - Full Study Diagram

### ALPINE AVE @ CARLING AVE

**Survey Date:** Wednesday, January 17, 2018

**WO#:** 37422

**Device:** Miovision

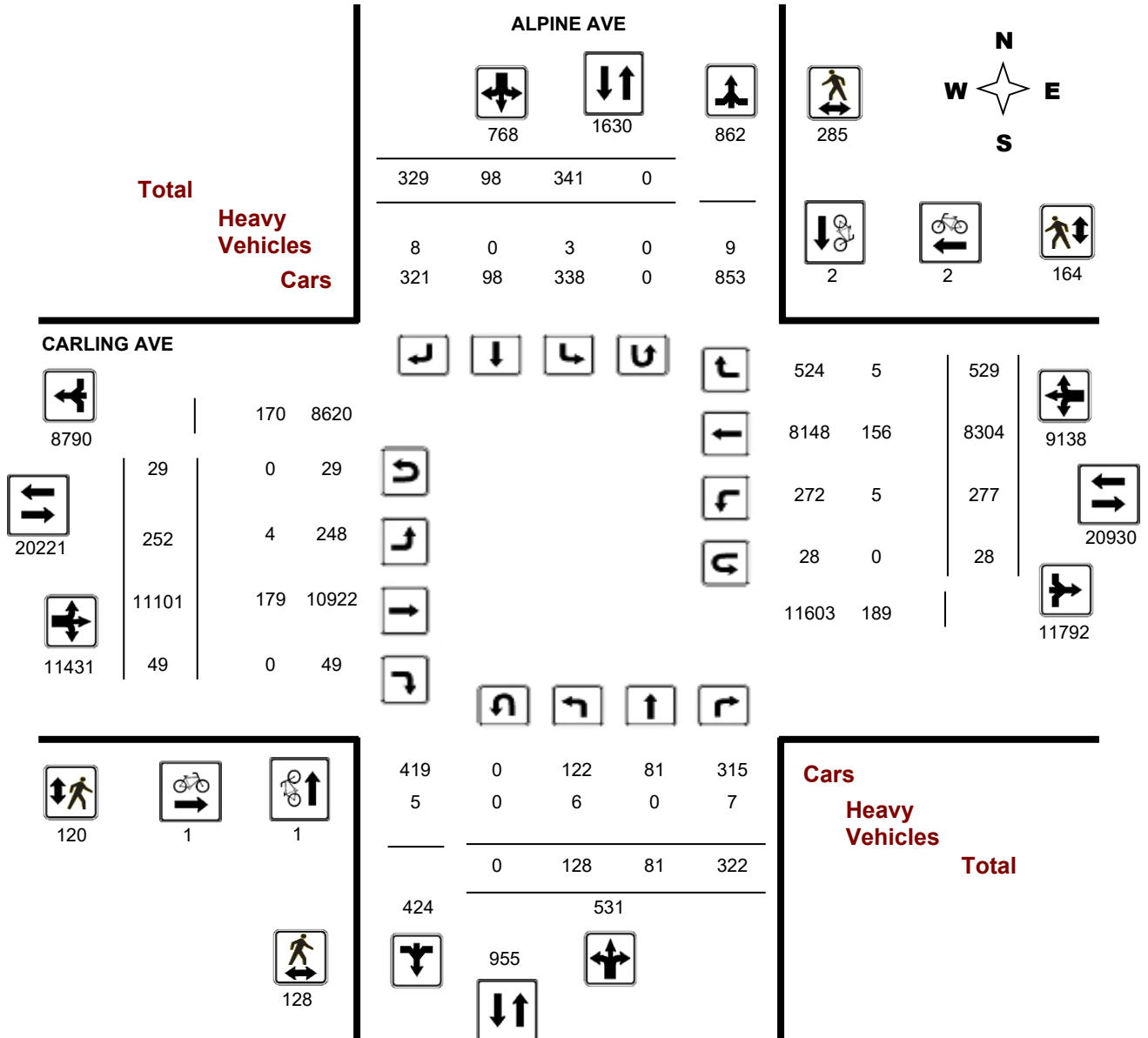

## Turning Movement Count - Full Study Summary Report

### ALPINE AVE @ CARLING AVE

**Survey Date:** Wednesday, January 17, 2011

**Total Observed U-Turns**

Northbound: 0      Southbound: 0  
Eastbound: 29      Westbound: 28

**AADT Factor**

1.00

**Full Study**

Period	ALPINE AVE									CARLING AVE									Grand Total		
	Northbound				Southbound					Eastbound			Westbound								
	LT	ST	RT	NB TOT	LT	ST	RT	SB TOT	STR TOT	LT	ST	RT	EB TOT	LT	ST	RT	WB TOT	STR TOT			
07:00 08:00	11	10	63	84	41	6	34	81	165	30	2586	3	2619	9	601	57	667	3286	3451		
08:00 09:00	22	7	87	116	41	9	52	102	218	29	2483	5	2517	30	857	68	955	3472	3690		
09:00 10:00	24	12	40	76	40	13	37	90	166	34	1566	7	1607	27	684	59	770	2377	2543		
11:30 12:30	11	10	33	54	48	14	49	111	165	47	658	9	714	24	659	66	749	1463	1628		
12:30 13:30	9	6	12	27	51	9	46	106	133	31	728	3	762	32	654	58	744	1506	1639		
15:00 16:00	18	9	33	60	31	12	45	88	148	27	1074	4	1105	50	1544	76	1670	2775	2923		
16:00 17:00	17	13	27	57	43	15	32	90	147	23	1062	8	1093	46	1770	69	1885	2978	3125		
17:00 18:00	16	14	27	57	46	20	34	100	157	31	944	10	985	59	1535	76	1670	2655	2812		
<b>Sub Total</b>	128	81	322	531	341	98	329	768	1299	252	11101	49	11402	277	8304	529	9110	20512	21811		
<b>U Turns</b>				0				0	0				29				28	57	57		
<b>Total</b>	128	81	322	531	341	98	329	768	1299	252	11101	49	11431	277	8304	529	9138	20569	21868		
<b>EQ 12Hr</b>	178	113	448	738	474	136	457	1068	1806	350	15430	68	15889	385	11543	735	12702	28591	30397		
Note: These values are calculated by multiplying the totals by the appropriate expansion factor.													<b>1.39</b>								
<b>AVG 12Hr</b>	178	113	448	738	474	136	457	1068	1806	350	15430	68	15889	385	11543	735	12702	28591	30397		
Note: These volumes are calculated by multiplying the Equivalent 12 hr. totals by the AADT factor.													<b>1.00</b>								
<b>AVG 24Hr</b>	233	147	586	967	621	178	599	1398	2365	459	20214	89	20815	504	15121	963	16639	37454	39819		
Note: These volumes are calculated by multiplying the Average Daily 12 hr. totals by 12 to 24 expansion factor.													<b>1.31</b>								

**Comments:**

Note: U-Turns provided for approach totals. Refer to 'U-Turn' Report for specific breakdown.



Turning Movement Count - 15 Minute Summary Report

ALPINE AVE @ CARLING AVE

Survey Date: Wednesday, January 17, 2018

Total Observed U-Turns

Northbound: 0 Southbound: 0
Eastbound: 29 Westbound: 28

Table with columns for Time Period, Northbound (LT, ST, RT, N TOT), Southbound (LT, ST, RT, S TOT, STR TOT), Eastbound (LT, ST, RT, E TOT), Westbound (LT, ST, RT, W TOT, STR TOT), and Grand Total. Rows represent 15-minute intervals from 07:00 to 18:00.

Note: U-Turns are included in Totals.

Comment:





# Transportation Services - Traffic Services

## Turning Movement Count - Cyclist Volume Report

**Work Order**  
**37422**

### ALPINE AVE @ CARLING AVE

**Count Date:** Wednesday, January 17, 2018

**Start Time:** 07:00

Time Period	ALPINE AVE			CARLING AVE			Grand Total
	Northbound	Southbound	Street Total	Eastbound	Westbound	Street Total	
07:00 08:00	1	1	2	0	1	1	3
08:00 09:00	0	0	0	0	0	0	0
09:00 10:00	0	0	0	0	0	0	0
11:30 12:30	0	0	0	0	0	0	0
12:30 13:30	0	0	0	0	0	0	0
15:00 16:00	0	0	0	0	0	0	0
16:00 17:00	0	0	0	1	1	2	2
17:00 18:00	0	1	1	0	0	0	1
<b>Total .....</b>	<b>1</b>	<b>2</b>	<b>3</b>	<b>1</b>	<b>2</b>	<b>3</b>	<b>6</b>

**Comment:**

Note: These volumes consists of bicycles only (no mopeds or motorcycles) and ARE NOT included in the Turning Movement Count Summary.



# Transportation Services - Traffic Services

W.O.  
37422

## Turning Movement Count - Heavy Vehicle Report

### ALPINE AVE @ CARLING AVE

**Survey Date:** Wednesday, January 17, 2018

Time Period	ALPINE AVE									CARLING AVE									Grand Total	
	Northbound			Southbound			S TOT	STR TOT	Eastbound			Westbound			W TOT	STR TOT				
	LT	ST	RT	N TOT	LT	ST			RT	LT	ST	RT	E TOT	LT			ST	RT		
07:00 08:00	0	0	0	0	0	0	0	0	0	0	2	21	0	23	0	14	1	15	38	38
08:00 09:00	2	0	2	4	1	0	1	2	6	1	36	0	37	0	27	2	29	66	72	
09:00 10:00	0	0	2	2	1	0	2	3	5	0	39	0	39	1	21	0	22	61	66	
11:30 12:30	1	0	0	1	0	0	2	2	3	1	14	0	15	1	16	0	17	32	35	
12:30 13:30	0	0	0	0	0	0	1	1	1	0	21	0	21	1	22	1	24	45	46	
15:00 16:00	1	0	2	3	0	0	2	2	5	0	18	0	18	1	22	1	24	42	47	
16:00 17:00	2	0	1	3	1	0	0	1	4	0	17	0	17	1	15	0	16	33	37	
17:00 18:00	0	0	0	0	0	0	0	0	0	0	13	0	13	0	19	0	19	32	32	
<b>Sub Total</b>	<b>6</b>	<b>0</b>	<b>7</b>	<b>13</b>	<b>3</b>	<b>0</b>	<b>8</b>	<b>11</b>	<b>24</b>	<b>4</b>	<b>179</b>	<b>0</b>	<b>183</b>	<b>5</b>	<b>156</b>	<b>5</b>	<b>166</b>	<b>349</b>	<b>373</b>	
<b>U-Turns (Heavy Vehicles)</b>				<b>0</b>				<b>0</b>	<b>0</b>				<b>0</b>				<b>0</b>	<b>0</b>	<b>0</b>	
<b>Total</b>	<b>6</b>	<b>0</b>	<b>7</b>	<b>0</b>	<b>3</b>	<b>0</b>	<b>8</b>	<b>11</b>	<b>24</b>	<b>4</b>	<b>179</b>	<b>0</b>	<b>183</b>	<b>5</b>	<b>156</b>	<b>5</b>	<b>166</b>	<b>349</b>	<b>373</b>	

Heavy Vehicles include Buses, Single-Unit Trucks and Articulated Trucks. Further, they ARE included in the Turning Movement Count Summary.



# Transportation Services - Traffic Services

Work Order

37422

## Turning Movement Count - Pedestrian Volume Report

### ALPINE AVE @ CARLING AVE

Count Date: Wednesday, January 17, 2018

Start Time: 07:00

Time Period	NB Approach (E or W Crossing)	SB Approach (E or W Crossing)	Total	EB Approach (N or S Crossing)	WB Approach (N or S Crossing)	Total	Grand Total
07:00 07:15	0	4	4	0	1	1	5
07:15 07:30	1	4	5	0	3	3	8
07:30 07:45	5	6	11	1	6	7	18
07:45 08:00	8	7	15	1	5	6	21
<b>07:00 08:00</b>	<b>14</b>	<b>21</b>	<b>35</b>	<b>2</b>	<b>15</b>	<b>17</b>	<b>52</b>
08:00 08:15	3	6	9	4	5	9	18
08:15 08:30	8	13	21	1	10	11	32
08:30 08:45	12	7	19	3	3	6	25
08:45 09:00	4	10	14	3	9	12	26
<b>08:00 09:00</b>	<b>27</b>	<b>36</b>	<b>63</b>	<b>11</b>	<b>27</b>	<b>38</b>	<b>101</b>
09:00 09:15	4	2	6	2	2	4	10
09:15 09:30	4	3	7	0	4	4	11
09:30 09:45	1	9	10	2	5	7	17
09:45 10:00	1	8	9	2	1	3	12
<b>09:00 10:00</b>	<b>10</b>	<b>22</b>	<b>32</b>	<b>6</b>	<b>12</b>	<b>18</b>	<b>50</b>
11:30 11:45	0	5	5	2	6	8	13
11:45 12:00	0	9	9	2	0	2	11
12:00 12:15	2	11	13	4	3	7	20
12:15 12:30	3	9	12	4	1	5	17
<b>11:30 12:30</b>	<b>5</b>	<b>34</b>	<b>39</b>	<b>12</b>	<b>10</b>	<b>22</b>	<b>61</b>
12:30 12:45	0	4	4	1	3	4	8
12:45 13:00	3	8	11	1	6	7	18
13:00 13:15	5	16	21	1	4	5	26
13:15 13:30	2	13	15	0	5	5	20
<b>12:30 13:30</b>	<b>10</b>	<b>41</b>	<b>51</b>	<b>3</b>	<b>18</b>	<b>21</b>	<b>72</b>
15:00 15:15	3	12	15	4	2	6	21
15:15 15:30	8	17	25	9	15	24	49
15:30 15:45	13	8	21	2	8	10	31
15:45 16:00	3	14	17	7	6	13	30
<b>15:00 16:00</b>	<b>27</b>	<b>51</b>	<b>78</b>	<b>22</b>	<b>31</b>	<b>53</b>	<b>131</b>
16:00 16:15	2	14	16	10	5	15	31
16:15 16:30	4	10	14	7	2	9	23
16:30 16:45	2	9	11	10	5	15	26
16:45 17:00	5	7	12	5	2	7	19
<b>16:00 17:00</b>	<b>13</b>	<b>40</b>	<b>53</b>	<b>32</b>	<b>14</b>	<b>46</b>	<b>99</b>
17:00 17:15	8	11	19	8	16	24	43
17:15 17:30	6	18	24	10	7	17	41
17:30 17:45	3	6	9	10	3	13	22
17:45 18:00	5	5	10	4	11	15	25
<b>17:00 18:00</b>	<b>22</b>	<b>40</b>	<b>62</b>	<b>32</b>	<b>37</b>	<b>69</b>	<b>131</b>
<b>Total</b> .....	<b>128</b>	<b>285</b>	<b>413</b>	<b>120</b>	<b>164</b>	<b>284</b>	<b>697</b>

Comment:

## Turning Movement Count - 15 Min U-Turn Total Report

### ALPINE AVE @ CARLING AVE

**Survey Date:** Wednesday, January 17, 2018

Time Period		Northbound U-Turn Total	Southbound U-Turn Total	Eastbound U-Turn Total	Westbound U-Turn Total	Total
07:00	07:15	0	0	0	0	0
07:15	07:30	0	0	1	2	3
07:30	07:45	0	0	2	0	2
07:45	08:00	0	0	0	0	0
08:00	08:15	0	0	2	0	2
08:15	08:30	0	0	0	1	1
08:30	08:45	0	0	2	2	4
08:45	09:00	0	0	1	1	2
09:00	09:15	0	0	1	1	2
09:15	09:30	0	0	0	0	0
09:30	09:45	0	0	0	1	1
09:45	10:00	0	0	1	0	1
11:30	11:45	0	0	0	0	0
11:45	12:00	0	0	0	1	1
12:00	12:15	0	0	1	0	1
12:15	12:30	0	0	1	2	3
12:30	12:45	0	0	0	0	0
12:45	13:00	0	0	0	1	1
13:00	13:15	0	0	2	0	2
13:15	13:30	0	0	1	2	3
15:00	15:15	0	0	2	2	4
15:15	15:30	0	0	2	0	2
15:30	15:45	0	0	0	1	1
15:45	16:00	0	0	2	0	2
16:00	16:15	0	0	0	1	1
16:15	16:30	0	0	1	0	1
16:30	16:45	0	0	0	2	2
16:45	17:00	0	0	2	1	3
17:00	17:15	0	0	0	2	2
17:15	17:30	0	0	0	1	1
17:30	17:45	0	0	4	2	6
17:45	18:00	0	0	1	2	3
<b>Total</b>		0	0	29	28	57

## Turning Movement Count - Study Results

### CARLING AVE @ RICHMOND RD

**Survey Date:** Tuesday, January 12, 2016

**WO No:** 35634

**Start Time:** 07:00

**Device:** Miovision

### Full Study Diagram

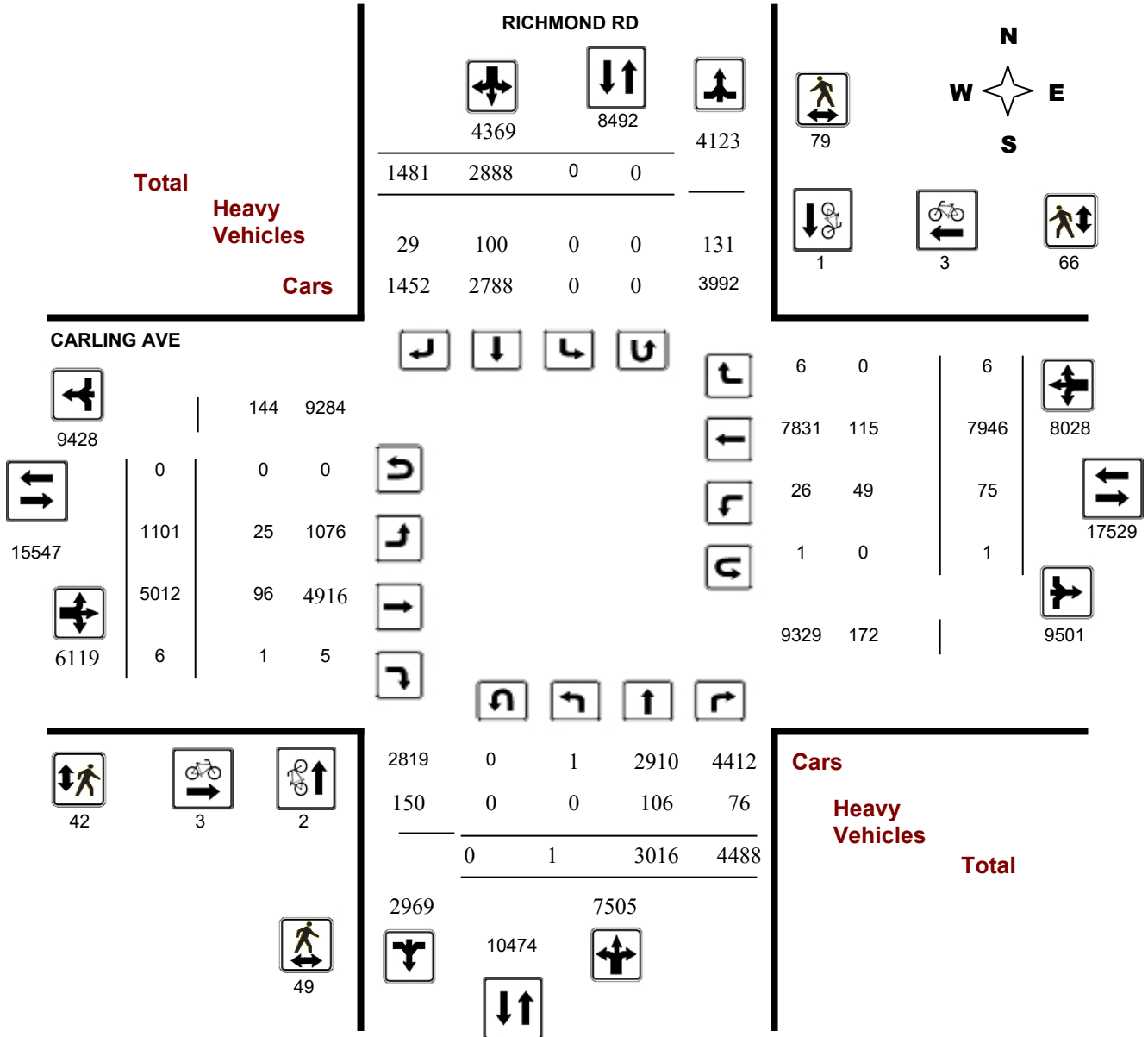

## Turning Movement Count - Study Results

### CARLING AVE @ RICHMOND RD

**Survey Date:** Tuesday, January 12, 2016

**WO No:** 35634

**Start Time:** 07:00

**Device:** Miovision

### Full Study Peak Hour Diagram

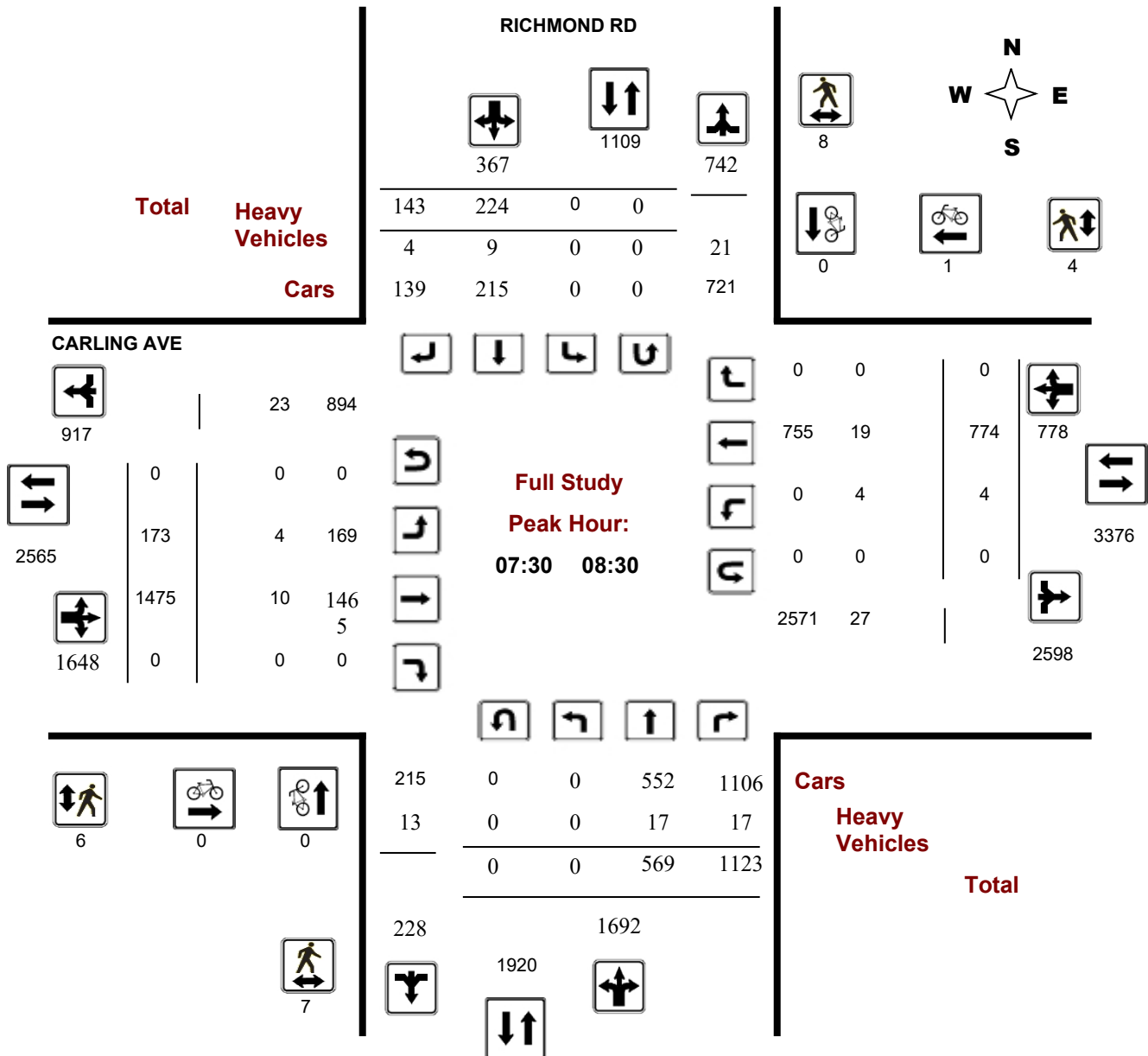

## Turning Movement Count - Peak Hour Diagram

### CARLING AVE @ RICHMOND RD

**Survey Date:** Tuesday, January 12, 2016

**Start Time:** 07:00

**WO No:** 35634

**Device:** Miovision

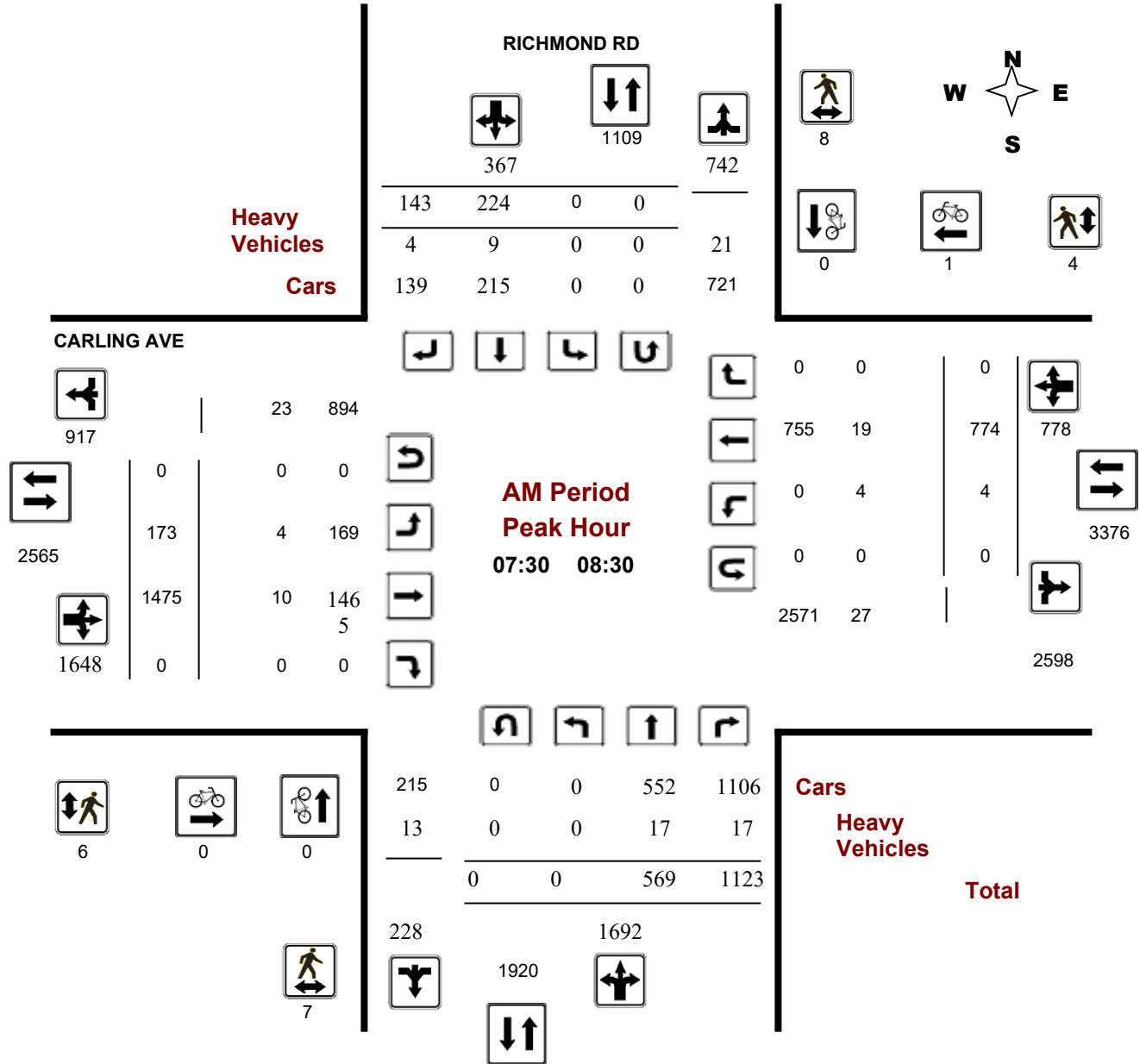

**Comments**



# Transportation Services - Traffic Services

## Turning Movement Count - Peak Hour Diagram

### CARLING AVE @ RICHMOND RD

**Survey Date:** Tuesday, January 12, 2016

**Start Time:** 07:00

**WO No:** 35634

**Device:** Miovision

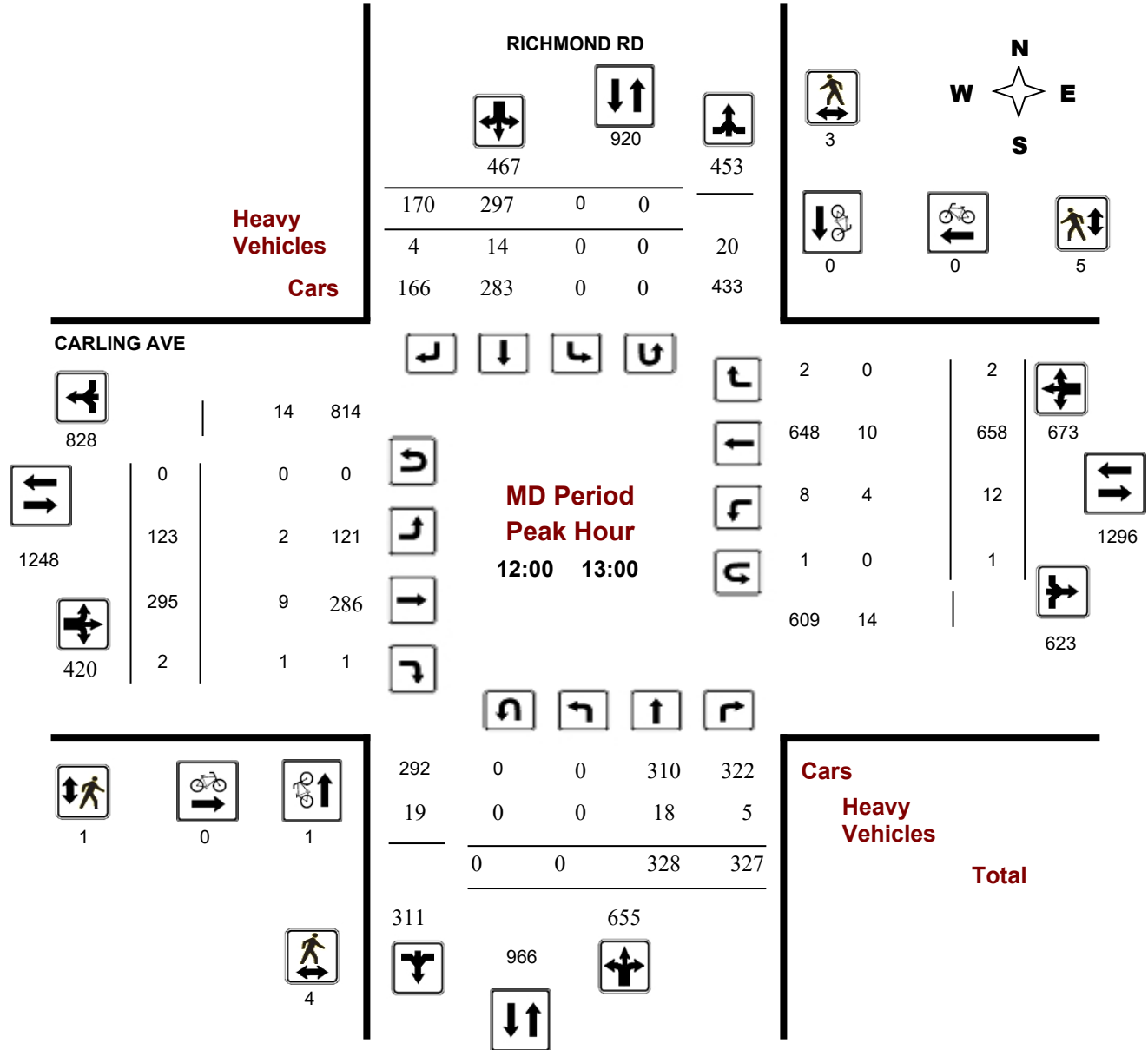



## Turning Movement Count - Peak Hour Diagram

### CARLING AVE @ RICHMOND RD

**Survey Date:** Tuesday, January 12, 2016

**Start Time:** 07:00

**WO No:** 35634

**Device:** Miovision

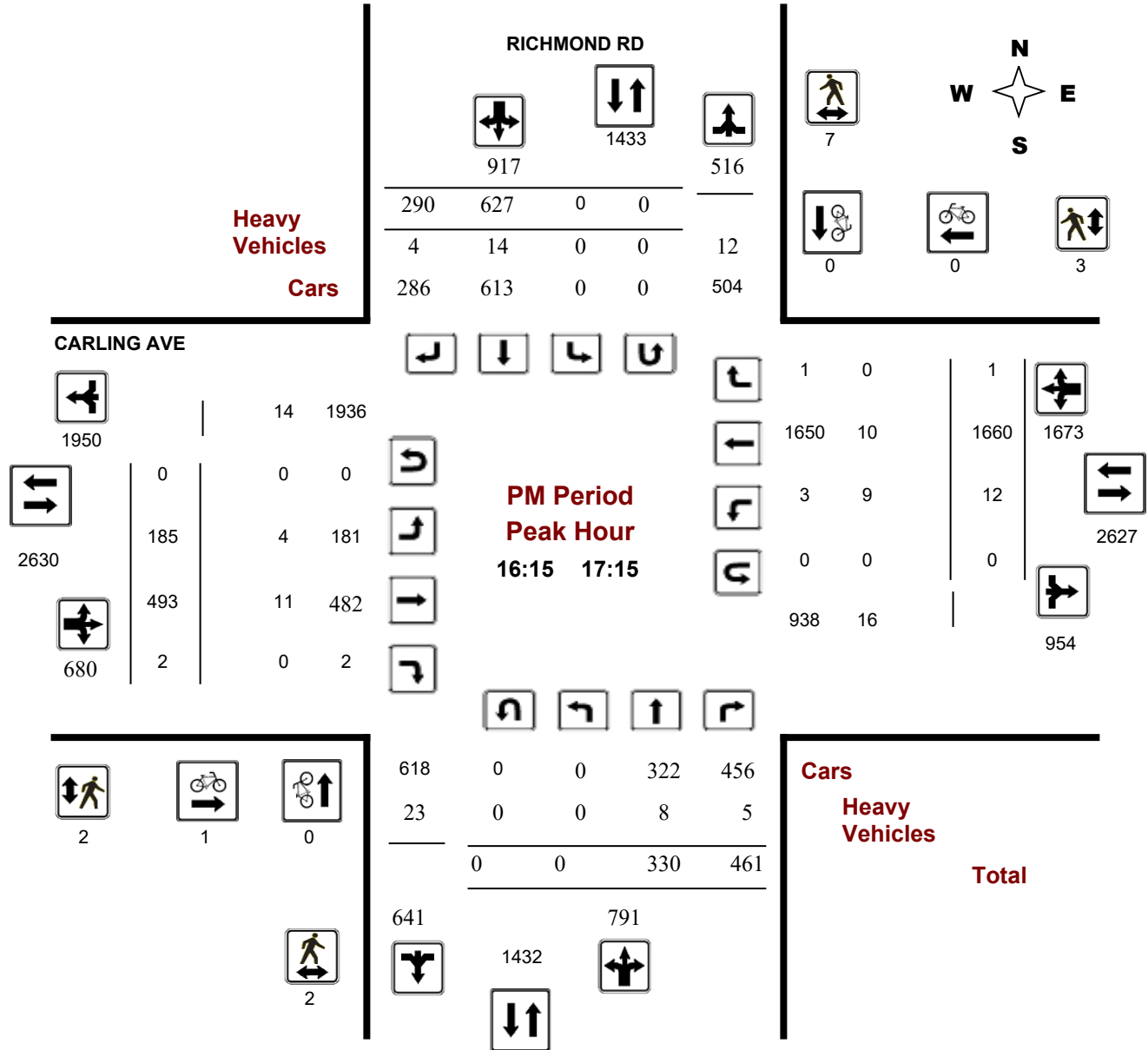

**Comments**



# Transportation Services - Traffic Services

## Turning Movement Count - Study Results

### CARLING AVE @ RICHMOND RD

**Survey Date:** Tuesday, January 12, 2016

**WO No:** 35634

**Start Time:** 07:00

**Device:** Miovision

### Full Study Summary (8 HR Standard)

**Survey Date:** Tuesday, January 12, 2016

**Total Observed U-Turns**

**AADT Factor**

Northbound: 0      Southbound: 0

1.10

Eastbound: 0      Westbound: 1

#### RICHMOND RD

#### CARLING AVE

Period	Northbound					Southbound					Eastbound					Westbound					Grand Total
	LT	ST	RT	NB TOT	STR TOT	LT	ST	RT	SB TOT	STR TOT	LT	ST	RT	EB TOT	STR TOT	LT	ST	RT	WB TOT	STR TOT	
07:00 08:00	0	459	925	1384	1644	0	175	85	260	1644	130	1334	0	1464	2178	5	709	0	714	2178	3822
08:00 09:00	0	585	1091	1676	2128	0	262	190	452	2128	160	1174	0	1334	2155	4	817	0	821	2155	4283
09:00 10:00	0	354	451	805	1209	0	245	159	404	1209	112	477	1	590	1257	4	663	0	667	1257	2466
11:30 12:30	0	307	314	621	1101	0	322	158	480	1101	115	269	1	385	1010	9	614	2	625	1010	2111
12:30 13:30	0	325	318	643	1106	0	293	170	463	1106	123	295	1	419	1068	18	630	1	649	1068	2174
15:00 16:00	0	323	507	830	1475	0	436	209	645	1475	136	507	0	643	1980	15	1322	0	1337	1980	3455
16:00 17:00	0	312	477	789	1669	0	606	274	880	1669	165	473	2	640	2327	10	1676	1	1687	2327	3996
17:00 18:00	1	351	405	757	1542	0	549	236	785	1542	160	483	1	644	2171	10	1515	2	1527	2171	3713
<b>Sub Total</b>	1	3016	4488	7505	11874	0	2888	1481	4369	11874	1101	5012	6	6119	14146	75	7946	6	8027	14146	26020
<b>U Turns</b>				0	0				0	0				0	1				1	1	1
<b>Total</b>	1	3016	4488	7505	11874	0	2888	1481	4369	11874	1101	5012	6	6119	14147	75	7946	6	8028	14147	26021
<b>EQ 12Hr</b>	1	4192	6238	10432	16505	0	4014	2059	6073	16505	1530	6967	8	8505	19664	104	11045	8	11159	19664	36169
Note: These values are calculated by multiplying the totals by the appropriate expansion factor.															<b>1.39</b>						
<b>AVG 12Hr</b>	1	4346	6467	10815	18156	0	4162	2134	6296	18156	1587	7222	9	8817	21630	108	11450	9	11568	21630	39786
Note: These volumes are calculated by multiplying the Equivalent 12 hr. totals by the AADT factor.															<b>1.1</b>						
<b>AVG 24Hr</b>	2	5693	8472	14167	22414	0	5452	2796	8247	22414	2078	9461	11	11551	26706	142	15000	11	15155	26706	49120
Note: These volumes are calculated by multiplying the Average Daily 12 hr. totals by 12 to 24 expansion factor.															<b>1.31</b>						

Note: U-Turns provided for approach totals. Refer to 'U-Turn' Report for specific breakdown.



# Transportation Services - Traffic Services

## Turning Movement Count - Study Results

### CARLING AVE @ RICHMOND RD

**Survey Date:** Tuesday, January 12, 2016

**WO No:** 35634

**Start Time:** 07:00

**Device:** Miovision

### Full Study 15 Minute Increments

#### RICHMOND RD

#### CARLING AVE

Northbound

Southbound

Eastbound

Westbound

Time Period	LT	ST	RT	N TOT	LT	ST	RT	S TOT	STR TOT	LT	ST	RT	E TOT	LT	ST	RT	W TOT	STR TOT	Grand Total
07:00 07:15	0	74	198	272	0	35	15	50	8	14	238	0	252	1	160	0	161	8	735
07:15 07:30	0	122	185	307	0	42	15	57	7	33	339	0	372	2	173	0	175	7	911
07:30 07:45	0	133	268	401	0	45	29	74	11	33	391	0	424	1	202	0	203	11	1102
07:45 08:00	0	130	274	404	0	53	26	79	9	50	366	0	416	1	174	0	175	9	1074
08:00 08:15	0	144	287	431	0	58	44	102	13	43	353	0	396	2	195	0	197	13	1126
08:15 08:30	0	162	294	456	0	68	44	112	14	47	365	0	412	0	203	0	203	14	1183
08:30 08:45	0	134	296	430	0	66	50	116	16	44	263	0	307	1	235	0	236	16	1089
08:45 09:00	0	145	214	359	0	70	52	122	8	26	193	0	219	1	184	0	185	8	885
09:00 09:15	0	91	150	241	0	45	42	87	12	30	190	0	220	2	202	0	204	12	752
09:15 09:30	0	110	103	213	0	53	41	94	11	23	113	0	136	0	178	0	178	11	621
09:30 09:45	0	71	98	169	0	83	36	119	12	25	97	0	122	1	146	0	147	12	557
09:45 10:00	0	82	100	182	0	64	40	104	8	34	77	1	112	1	137	0	138	8	536
11:30 11:45	0	69	85	154	0	83	31	114	12	30	62	0	92	1	150	0	151	12	511
11:45 12:00	0	75	69	144	0	78	51	129	12	26	52	0	78	6	143	1	150	12	501
12:00 12:15	0	83	82	165	0	78	32	110	10	32	80	0	112	1	167	1	169	10	556
12:15 12:30	0	80	78	158	0	83	44	127	8	27	75	1	103	1	154	0	156	8	544
12:30 12:45	0	78	71	149	0	80	51	131	10	25	65	1	91	6	168	1	175	10	546
12:45 13:00	0	87	96	183	0	56	43	99	13	39	75	0	114	4	169	0	173	13	569
13:00 13:15	0	89	72	161	0	76	33	109	10	29	91	0	120	3	154	0	157	10	547
13:15 13:30	0	71	79	150	0	81	43	124	12	30	64	0	94	5	139	0	144	12	512
15:00 15:15	0	78	124	202	0	84	53	137	13	29	106	0	135	4	240	0	244	13	718
15:15 15:30	0	75	132	207	0	99	44	143	9	36	144	0	180	4	315	0	319	9	849
15:30 15:45	0	94	139	233	0	132	48	180	15	35	138	0	173	4	374	0	378	15	964
15:45 16:00	0	76	112	188	0	121	64	185	6	36	119	0	155	3	393	0	396	6	924
16:00 16:15	0	77	123	200	0	128	54	182	8	28	100	1	129	2	429	0	431	8	942
16:15 16:30	0	76	125	201	0	139	82	221	10	36	120	1	157	2	407	0	409	10	988
16:30 16:45	0	80	132	212	0	178	67	245	9	50	124	0	174	3	426	0	429	9	1060
16:45 17:00	0	79	97	176	0	161	71	232	3	51	129	0	180	3	414	1	418	3	1006
17:00 17:15	0	95	107	202	0	149	70	219	9	48	120	1	169	4	413	0	417	9	1007
17:15 17:30	1	81	112	194	0	137	66	203	5	37	121	0	158	2	390	0	392	5	947
17:30 17:45	0	88	97	185	0	129	50	179	5	33	114	0	147	0	364	0	364	5	875
17:45 18:00	0	87	89	176	0	134	50	184	3	42	128	0	170	4	348	2	354	3	884
<b>Total:</b>	<b>1</b>	<b>3016</b>	<b>4488</b>	<b>7505</b>	<b>0</b>	<b>2888</b>	<b>1481</b>	<b>4369</b>	<b>311</b>	<b>1101</b>	<b>5012</b>	<b>6</b>	<b>6119</b>	<b>75</b>	<b>7946</b>	<b>6</b>	<b>8028</b>	<b>311</b>	<b>26,021</b>

Note: U-Turns are included in Totals.



# Transportation Services - Traffic Services

## Turning Movement Count - Study Results

### CARLING AVE @ RICHMOND RD

**Survey Date:** Tuesday, January 12, 2016

**WO No:** 35634

**Start Time:** 07:00

**Device:** Miovision

### Full Study Cyclist Volume

Time Period	RICHMOND RD			CARLING AVE			Grand Total
	Northbound	Southbound	Street Total	Eastbound	Westbound	Street Total	
07:00 07:15	0	0	0	0	0	0	0
07:15 07:30	0	0	0	0	0	0	0
07:30 07:45	0	0	0	0	0	0	0
07:45 08:00	0	0	0	0	0	0	0
08:00 08:15	0	0	0	0	1	1	1
08:15 08:30	0	0	0	0	0	0	0
08:30 08:45	0	0	0	0	0	0	0
08:45 09:00	0	0	0	1	0	1	1
09:00 09:15	0	0	0	0	0	0	0
09:15 09:30	0	0	0	0	0	0	0
09:30 09:45	0	0	0	0	0	0	0
09:45 10:00	0	0	0	0	0	0	0
11:30 11:45	0	0	0	0	0	0	0
11:45 12:00	0	0	0	0	0	0	0
12:00 12:15	0	0	0	0	0	0	0
12:15 12:30	1	0	1	0	0	0	1
12:30 12:45	0	0	0	0	0	0	0
12:45 13:00	0	0	0	0	0	0	0
13:00 13:15	0	1	1	0	0	0	1
13:15 13:30	0	0	0	0	0	0	0
15:00 15:15	0	0	0	0	0	0	0
15:15 15:30	0	0	0	0	0	0	0
15:30 15:45	0	0	0	0	0	0	0
15:45 16:00	0	0	0	0	0	0	0
16:00 16:15	0	0	0	1	0	1	1
16:15 16:30	0	0	0	0	0	0	0
16:30 16:45	0	0	0	0	0	0	0
16:45 17:00	0	0	0	0	0	0	0
17:00 17:15	0	0	0	1	0	1	1
17:15 17:30	0	0	0	0	0	0	0
17:30 17:45	0	0	0	0	0	0	0
17:45 18:00	1	0	1	0	2	2	3
<b>Total</b>	<b>2</b>	<b>1</b>	<b>3</b>	<b>3</b>	<b>3</b>	<b>6</b>	<b>9</b>



# Transportation Services - Traffic Services

## Turning Movement Count - Study Results

### CARLING AVE @ RICHMOND RD

**Survey Date:** Tuesday, January 12, 2016

**WO No:** 35634

**Start Time:** 07:00

**Device:** Miovision

### Full Study Pedestrian Volume

#### RICHMOND RD

#### CARLING AVE

Time Period	NB Approach (E or W Crossing)	SB Approach (E or W Crossing)	Total	EB Approach (N or S Crossing)	WB Approach (N or S Crossing)	Total	Grand Total
07:00 07:15	1	2	3	0	0	0	3
07:15 07:30	5	3	8	1	0	1	9
07:30 07:45	2	1	3	1	0	1	4
07:45 08:00	2	1	3	0	1	1	4
08:00 08:15	1	2	3	2	1	3	6
08:15 08:30	2	4	6	3	2	5	11
08:30 08:45	5	3	8	3	6	9	17
08:45 09:00	3	0	3	0	3	3	6
09:00 09:15	0	0	0	0	0	0	0
09:15 09:30	1	3	4	0	2	2	6
09:30 09:45	2	1	3	0	1	1	4
09:45 10:00	2	1	3	0	4	4	7
11:30 11:45	0	1	1	0	0	0	1
11:45 12:00	1	0	1	1	3	4	5
12:00 12:15	2	1	3	0	2	2	5
12:15 12:30	1	1	2	0	2	2	4
12:30 12:45	0	0	0	1	1	2	2
12:45 13:00	1	1	2	0	0	0	2
13:00 13:15	0	5	5	2	4	6	11
13:15 13:30	1	7	8	1	3	4	12
15:00 15:15	0	2	2	1	4	5	7
15:15 15:30	4	3	7	2	4	6	13
15:30 15:45	3	8	11	8	5	13	24
15:45 16:00	1	4	5	3	3	6	11
16:00 16:15	0	6	6	2	0	2	8
16:15 16:30	0	3	3	0	0	0	3
16:30 16:45	0	3	3	1	0	1	4
16:45 17:00	0	1	1	0	0	0	1
17:00 17:15	2	0	2	1	3	4	6
17:15 17:30	1	7	8	4	1	5	13
17:30 17:45	2	2	4	2	3	5	9
17:45 18:00	4	3	7	3	8	11	18
<b>Total</b> .....	<b>49</b>	<b>79</b>	<b>128</b>	<b>42</b>	<b>66</b>	<b>108</b>	<b>236</b>



# Transportation Services - Traffic Services

## Turning Movement Count - Study Results

### CARLING AVE @ RICHMOND RD

**Survey Date:** Tuesday, January 12, 2016

**WO No:** 35634

**Start Time:** 07:00

**Device:** Miovision

### Full Study Heavy Vehicles

#### RICHMOND RD

#### CARLING AVE

Northbound

Southbound

Eastbound

Westbound

Time Period	Northbound			N TOT	Southbound			S TOT	STR TOT	Eastbound			E TOT	Westbound			W TOT	STR TOT	Grand Total
	LT	ST	RT		LT	ST	RT			LT	ST	RT		LT	ST	RT			
07:00 07:15	0	5	2	7	0	1	0	1	8	0	1	0	1	1	1	0	2	3	11
07:15 07:30	0	1	2	3	0	3	1	4	7	1	4	0	5	2	2	0	4	9	16
07:30 07:45	0	5	4	9	0	2	0	2	11	0	3	0	3	1	3	0	4	7	18
07:45 08:00	0	2	5	7	0	2	0	2	9	1	1	0	2	1	5	0	6	8	17
08:00 08:15	0	3	6	9	0	3	1	4	13	3	3	0	6	2	5	0	7	13	26
08:15 08:30	0	7	2	9	0	2	3	5	14	0	3	0	3	0	6	0	6	9	23
08:30 08:45	0	3	6	9	0	3	4	7	16	2	6	0	8	1	5	0	6	14	30
08:45 09:00	0	2	3	5	0	3	0	3	8	3	5	0	8	1	3	0	4	12	20
09:00 09:15	0	6	3	9	0	3	0	3	12	0	4	0	4	2	6	0	8	12	24
09:15 09:30	0	7	2	9	0	1	1	2	11	1	5	0	6	0	5	0	5	11	22
09:30 09:45	0	3	2	5	0	6	1	7	12	1	2	0	3	1	2	0	3	6	18
09:45 10:00	0	3	1	4	0	3	1	4	8	0	3	0	3	1	1	0	2	5	13
11:30 11:45	0	3	5	8	0	2	2	4	12	0	5	0	5	1	4	0	5	10	22
11:45 12:00	0	5	3	8	0	3	1	4	12	1	3	0	4	1	5	0	6	10	22
12:00 12:15	0	4	1	5	0	5	0	5	10	0	2	0	2	1	1	0	2	4	14
12:15 12:30	0	3	2	5	0	3	0	3	8	1	2	1	4	1	3	0	4	8	16
12:30 12:45	0	4	1	5	0	4	1	5	10	1	4	0	5	1	1	0	2	7	17
12:45 13:00	0	7	1	8	0	2	3	5	13	0	1	0	1	1	5	0	6	7	20
13:00 13:15	0	1	4	5	0	4	1	5	10	2	3	0	5	1	3	0	4	9	19
13:15 13:30	0	6	1	7	0	5	0	5	12	0	1	0	1	1	6	0	7	8	20
15:00 15:15	0	4	5	9	0	4	0	4	13	0	2	0	2	3	4	0	7	9	22
15:15 15:30	0	3	0	3	0	6	0	6	9	1	2	0	3	4	6	0	10	13	22
15:30 15:45	0	3	2	5	0	7	3	10	15	1	7	0	8	2	8	0	10	18	33
15:45 16:00	0	2	2	4	0	2	0	2	6	0	6	0	6	2	6	0	8	14	20
16:00 16:15	0	3	1	4	0	4	0	4	8	2	3	0	5	2	4	0	6	11	19
16:15 16:30	0	3	1	4	0	4	2	6	10	1	2	0	3	2	1	0	3	6	16
16:30 16:45	0	3	4	7	0	2	0	2	9	2	6	0	8	3	3	0	6	14	23
16:45 17:00	0	1	0	1	0	1	1	2	3	1	1	0	2	2	4	0	6	8	11
17:00 17:15	0	1	0	1	0	7	1	8	9	0	2	0	2	2	2	0	4	6	15
17:15 17:30	0	2	2	4	0	1	0	1	5	0	1	0	1	2	1	0	3	4	9
17:30 17:45	0	1	1	2	0	1	2	3	5	0	2	0	2	0	1	0	1	3	8
17:45 18:00	0	0	2	2	0	1	0	1	3	0	1	0	1	4	3	0	7	8	11
Total: None	0	106	76	182	0	100	29	129	311	25	96	1	122	49	115	0	164	286	597



# Transportation Services - Traffic Services

## Turning Movement Count - Study Results

### CARLING AVE @ RICHMOND RD

**Survey Date:** Tuesday, January 12, 2016

**WO No:** 35634

**Start Time:** 07:00

**Device:** Miovision

### Full Study 15 Minute U-Turn Total

RICHMOND RD

CARLING AVE

Time Period		Northbound U-Turn Total	Southbound U-Turn Total	Eastbound U-Turn Total	Westbound U-Turn Total	Total
07:00	07:15	0	0	0	0	0
07:15	07:30	0	0	0	0	0
07:30	07:45	0	0	0	0	0
07:45	08:00	0	0	0	0	0
08:00	08:15	0	0	0	0	0
08:15	08:30	0	0	0	0	0
08:30	08:45	0	0	0	0	0
08:45	09:00	0	0	0	0	0
09:00	09:15	0	0	0	0	0
09:15	09:30	0	0	0	0	0
09:30	09:45	0	0	0	0	0
09:45	10:00	0	0	0	0	0
11:30	11:45	0	0	0	0	0
11:45	12:00	0	0	0	0	0
12:00	12:15	0	0	0	0	0
12:15	12:30	0	0	0	1	1
12:30	12:45	0	0	0	0	0
12:45	13:00	0	0	0	0	0
13:00	13:15	0	0	0	0	0
13:15	13:30	0	0	0	0	0
15:00	15:15	0	0	0	0	0
15:15	15:30	0	0	0	0	0
15:30	15:45	0	0	0	0	0
15:45	16:00	0	0	0	0	0
16:00	16:15	0	0	0	0	0
16:15	16:30	0	0	0	0	0
16:30	16:45	0	0	0	0	0
16:45	17:00	0	0	0	0	0
17:00	17:15	0	0	0	0	0
17:15	17:30	0	0	0	0	0
17:30	17:45	0	0	0	0	0
17:45	18:00	0	0	0	0	0
Total		0	0	0	1	1

**Survey Date:** Thursday, August 11, 2016

**Start Time:** 07:00

**WO No:**

36168

**Device:**

Miovision

### Full Study Diagram

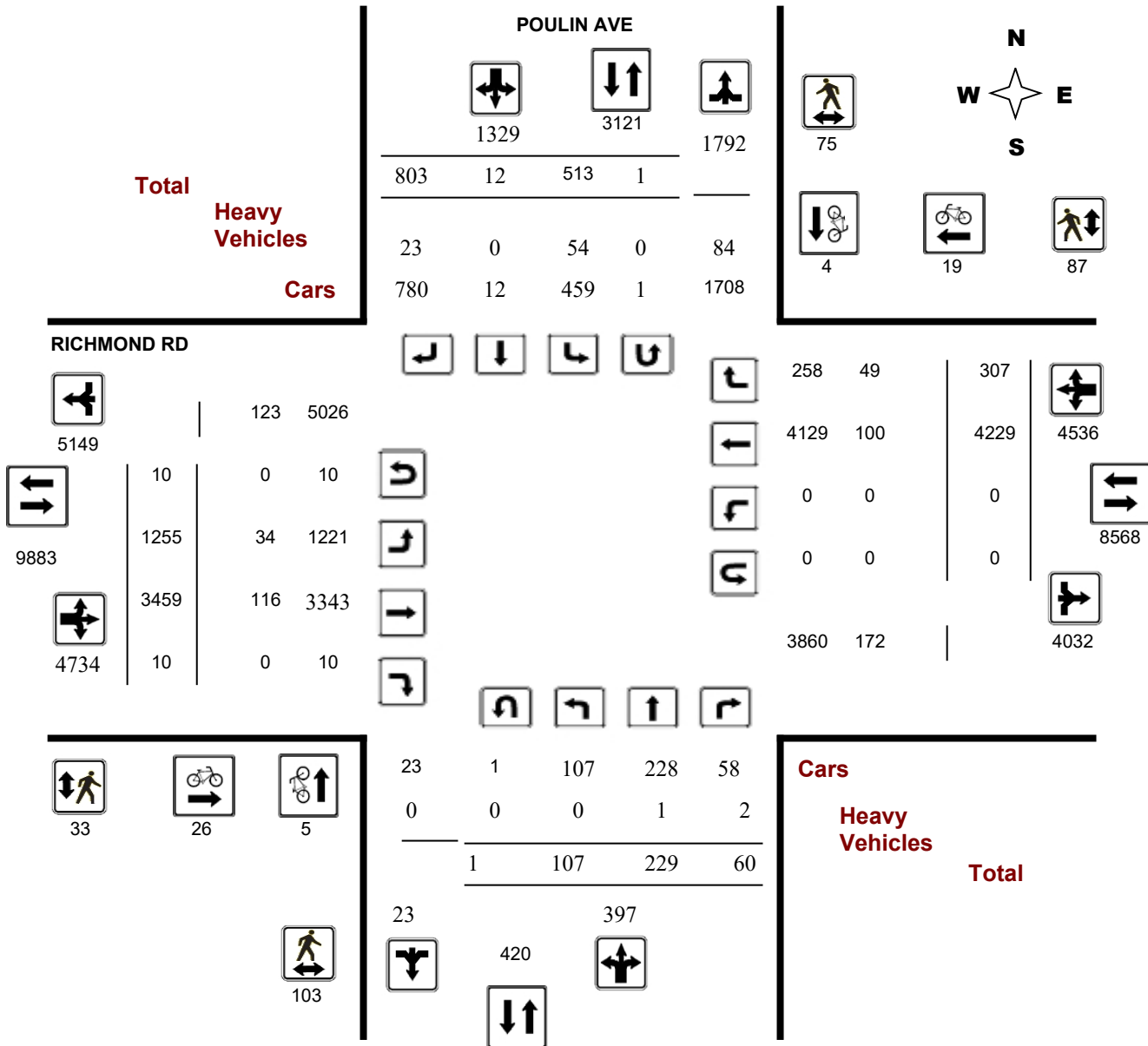



## Turning Movement Count - Study Results

### POULIN AVE @ RICHMOND RD

**Survey Date:** Thursday, August 11, 2016

**WO No:** 36168

**Start Time:** 07:00

**Device:** Miovision

### Full Study Peak Hour Diagram

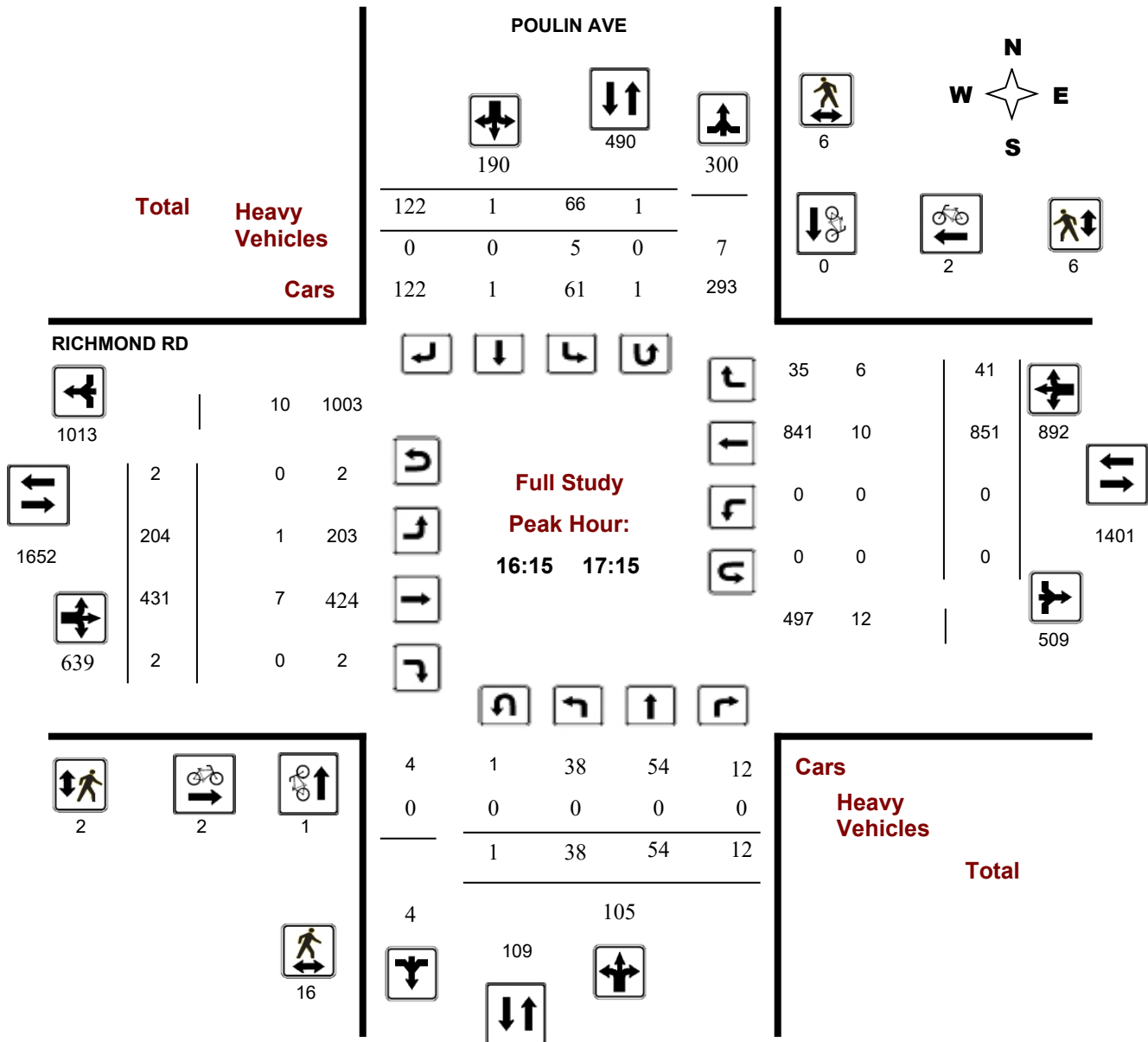

## Turning Movement Count - Peak Hour Diagram

### POULIN AVE @ RICHMOND RD

**Survey Date:** Thursday, August 11, 2016

**Start Time:** 07:00

**WO No:** 36168

**Device:** Miovision

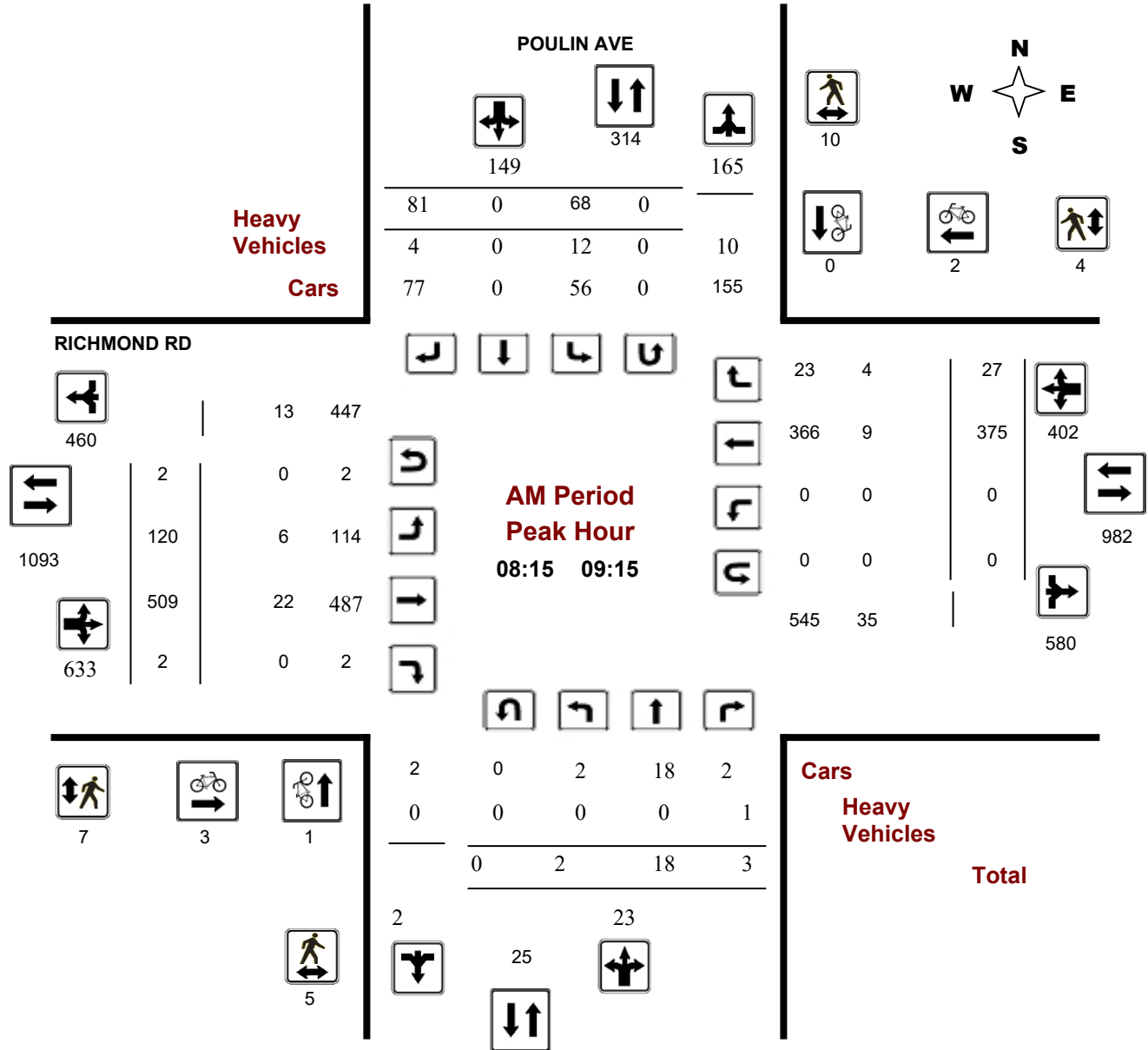

**Comments**

## Turning Movement Count - Peak Hour Diagram

### POULIN AVE @ RICHMOND RD

**Survey Date:** Thursday, August 11, 2016

**Start Time:** 07:00

**WO No:** 36168

**Device:** Miovision

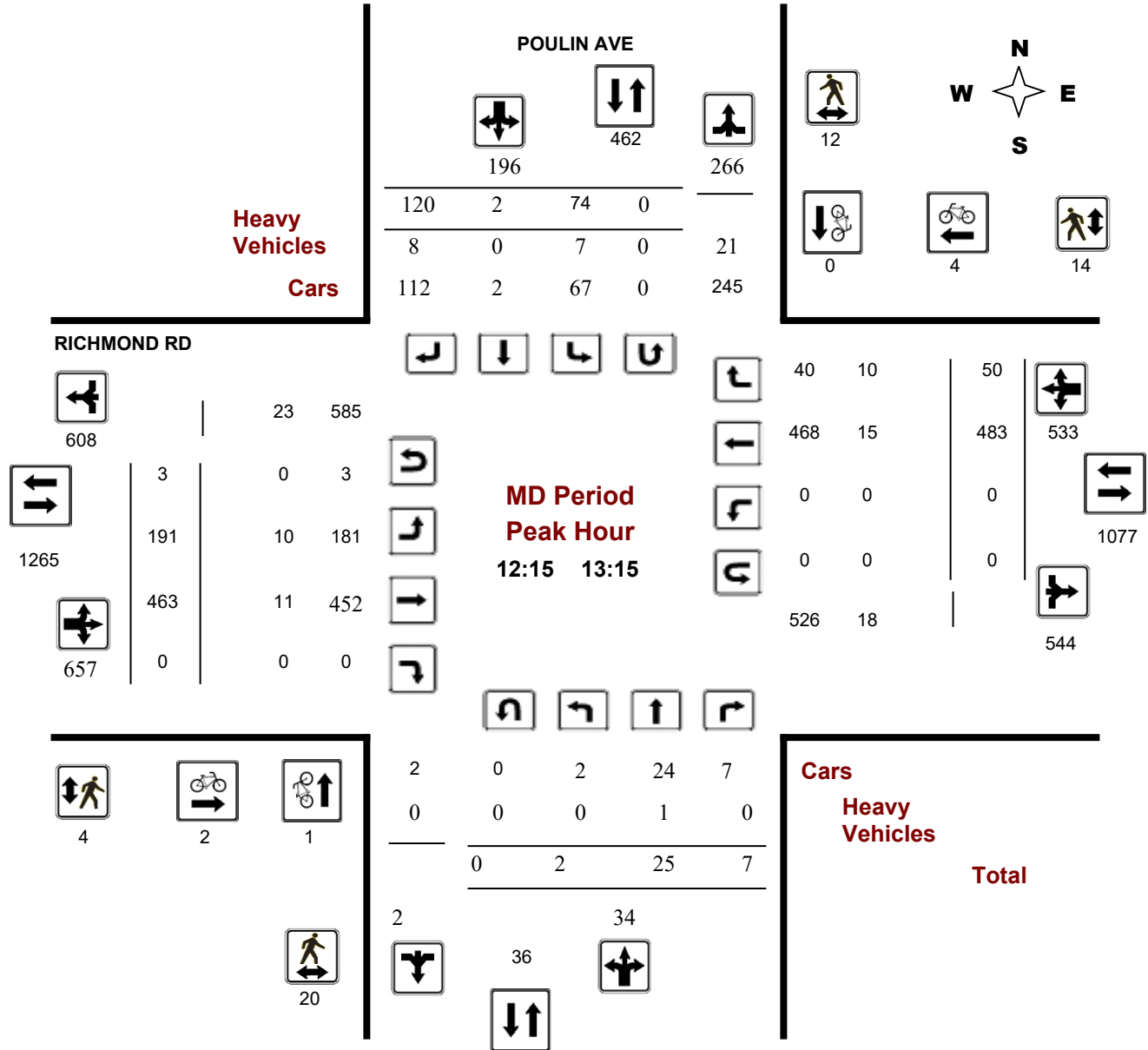

## Turning Movement Count - Peak Hour Diagram

### POULIN AVE @ RICHMOND RD

**Survey Date:** Thursday, August 11, 2016

**Start Time:** 07:00

**WO No:** 36168

**Device:** Miovision

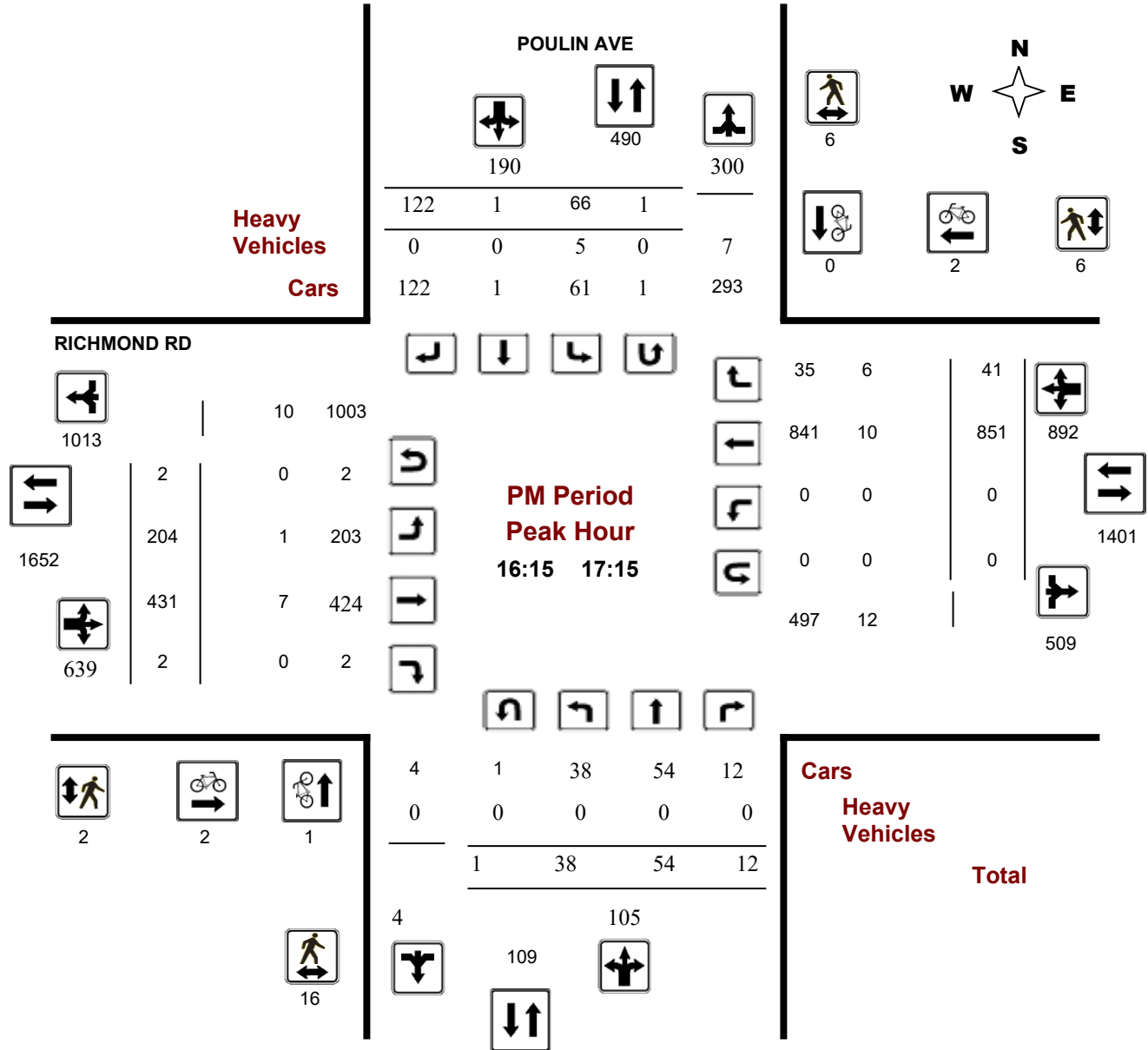



# Transportation Services - Traffic Services

## Turning Movement Count - Study Results

### POULIN AVE @ RICHMOND RD

**Survey Date:** Thursday, August 11, 2016

**WO No:** 36168

**Start Time:** 07:00

**Device:** Miovision

### Full Study Summary (8 HR Standard)

**Survey Date:** Thursday, August 11, 2016

**Total Observed U-Turns**  
 Northbound: 1      Southbound: 1  
 Eastbound: 10      Westbound: 0

**AADT Factor**  
 .90

#### POULIN AVE

#### RICHMOND RD

Period	Northbound					Southbound					Eastbound					Westbound					Grand Total
	LT	ST	RT	NB TOT	STR TOT	LT	ST	RT	SB TOT	STR TOT	LT	ST	RT	EB TOT	STR TOT	LT	ST	RT	WB TOT	STR TOT	
07:00 08:00	0	12	2	14	125	63	0	48	111	125	71	465	0	536	829	0	271	22	293	829	954
08:00 09:00	2	17	4	23	159	65	0	71	136	159	115	517	2	634	1040	0	379	27	406	1040	1199
09:00 10:00	0	13	5	18	158	59	0	81	140	158	127	399	1	527	929	0	368	34	402	929	1087
11:30 12:30	5	20	7	32	213	73	8	100	181	213	175	401	2	578	1080	0	463	39	502	1080	1293
12:30 13:30	4	25	6	35	226	73	1	117	191	226	193	451	1	645	1181	0	487	49	536	1181	1407
15:00 16:00	30	43	10	83	270	58	0	129	187	270	166	400	1	567	1320	0	706	47	753	1320	1590
16:00 17:00	34	56	13	103	298	70	2	123	195	298	196	413	1	610	1479	0	825	44	869	1479	1777
17:00 18:00	32	43	13	88	275	52	1	134	187	275	212	413	2	627	1402	0	730	45	775	1402	1677
<b>Sub Total</b>	107	229	60	396	1724	513	12	803	1328	1724	1255	3459	10	4724	9260	0	4229	307	4536	9260	10984
<b>U Turns</b>				1	2				1	2				10	10				0	10	12
<b>Total</b>	107	229	60	397	1726	513	12	803	1329	1726	1255	3459	10	4734	9270	0	4229	307	4536	9270	10996
<b>EQ 12Hr</b>	149	318	83	552	2399	713	17	1116	1847	2399	1744	4808	14	6580	12885	0	5878	427	6305	12885	15284
Note: These values are calculated by multiplying the totals by the appropriate expansion factor.															<b>1.39</b>						
<b>AVG 12Hr</b>	126	270	71	468	2159	605	14	947	1567	2159	1480	4078	12	5581	11596	0	4986	362	5348	11596	13756
Note: These volumes are calculated by multiplying the Equivalent 12 hr. totals by the AADT factor.															<b>0.9</b>						
<b>AVG 24Hr</b>	165	354	93	613	2666	792	19	1240	2053	2666	1938	5342	15	7312	14318	0	6532	474	7006	14318	16984
Note: These volumes are calculated by multiplying the Average Daily 12 hr. totals by 12 to 24 expansion factor.															<b>1.31</b>						

Note: U-Turns provided for approach totals. Refer to 'U-Turn' Report for specific breakdown.



# Transportation Services - Traffic Services

## Turning Movement Count - Study Results

### POULIN AVE @ RICHMOND RD

**Survey Date:** Thursday, August 11, 2016

**WO No:** 36168

**Start Time:** 07:00

**Device:** Miovision

### Full Study 15 Minute Increments

#### POULIN AVE

#### RICHMOND RD

Northbound

Southbound

Eastbound

Westbound

Time Period	LT	ST	RT	N TOT	LT	ST	RT	S TOT	STR TOT	LT	ST	RT	E TOT	LT	ST	RT	W TOT	STR TOT	Grand Total
09:00-09:15	0	3	1	4	14	0	24	38	6	27	101	0	129	0	93	5	98	6	269
09:15-09:30	0	8	3	11	13	0	20	33	3	30	92	0	122	0	88	6	94	3	260
09:30-09:45	0	1	0	1	15	0	16	31	2	40	101	1	143	0	89	12	101	2	276
09:45-10:00	0	1	1	2	17	0	21	38	3	30	105	0	135	0	98	11	109	3	284
11:30-11:45	3	1	1	5	15	3	23	41	3	47	91	1	139	0	102	6	108	3	293
11:45-12:00	1	3	1	5	16	2	23	41	1	48	100	1	149	0	111	9	120	1	315
12:00-12:15	0	6	2	8	18	2	27	47	4	42	112	0	154	0	127	14	141	4	350
12:15-12:30	1	10	3	14	24	1	27	52	3	38	98	0	136	0	123	10	133	3	335
12:30-12:45	0	8	3	11	15	0	32	47	5	46	124	0	172	0	126	14	140	5	370
12:45-13:00	0	4	1	5	17	1	33	51	4	60	121	0	182	0	99	11	110	4	348
13:00-13:15	1	3	0	4	18	0	28	46	4	47	120	0	167	0	135	15	150	4	367
13:15-13:30	3	10	2	15	23	0	24	47	3	40	86	1	127	0	127	9	136	3	325
15:00-15:15	11	18	1	30	13	0	45	58	3	44	99	0	143	0	149	11	160	3	391
15:15-15:30	4	9	2	15	15	0	24	39	2	29	95	1	125	0	174	16	190	2	369
15:30-15:45	7	9	7	23	14	0	34	48	2	50	108	0	159	0	187	10	197	2	427
15:45-16:00	8	7	0	15	16	0	26	42	0	43	98	0	142	0	196	10	206	0	405
16:00-16:15	4	16	5	25	17	1	33	51	1	50	103	0	153	0	191	11	202	1	431
16:15-16:30	12	13	6	31	13	0	24	38	1	42	87	1	130	0	205	14	219	1	418
16:30-16:45	9	8	1	19	22	0	32	54	1	55	125	0	181	0	219	14	233	1	487
16:45-17:00	9	19	1	29	18	1	34	53	2	49	98	0	148	0	210	5	215	2	445
17:00-17:15	8	14	4	26	13	0	32	45	1	58	121	1	180	0	217	8	225	1	476
17:15-17:30	9	8	4	21	11	1	31	43	1	58	106	1	165	0	174	14	188	1	417
17:30-17:45	11	9	4	24	18	0	34	52	1	48	95	0	143	0	179	10	189	1	408
17:45-18:00	4	12	1	17	10	0	37	47	1	48	91	0	139	0	160	13	173	1	376
08:45-09:00	0	3	1	4	21	0	16	37	4	29	118	1	149	0	87	12	99	4	289
07:00-07:15	0	3	0	3	13	0	10	23	2	18	81	0	99	0	66	3	69	2	194
08:00-08:15	0	2	2	4	11	0	14	25	4	22	109	0	131	0	97	5	102	4	262
07:15-07:30	0	3	1	4	16	0	10	26	2	21	115	0	136	0	52	5	57	2	223
07:30-07:45	0	5	0	5	23	0	16	39	3	9	130	0	139	0	77	7	84	3	267
07:45-08:00	0	1	1	2	11	0	12	23	1	23	139	0	162	0	76	7	83	1	270
08:15-08:30	2	9	0	11	17	0	17	34	4	27	137	0	164	0	98	5	103	4	312
08:30-08:45	0	3	1	4	16	0	24	40	3	37	153	1	191	0	97	5	102	3	337
<b>Total:</b>	<b>107</b>	<b>229</b>	<b>60</b>	<b>397</b>	<b>513</b>	<b>12</b>	<b>803</b>	<b>1329</b>	<b>80</b>	<b>1255</b>	<b>3459</b>	<b>10</b>	<b>4734</b>	<b>0</b>	<b>4229</b>	<b>307</b>	<b>4536</b>	<b>80</b>	<b>10,996</b>

Note: U-Turns are included in Totals.



# Transportation Services - Traffic Services

## Turning Movement Count - Study Results

### POULIN AVE @ RICHMOND RD

**Survey Date:** Thursday, August 11, 2016

**WO No:** 36168

**Start Time:** 07:00

**Device:** Miovision

### Full Study Cyclist Volume

Time Period	POULIN AVE			RICHMOND RD			Grand Total
	Northbound	Southbound	Street Total	Eastbound	Westbound	Street Total	
09:00-09:15	0	0	0	1	0	1	1
09:15-09:30	0	0	0	1	0	1	1
09:30-09:45	0	0	0	2	0	2	2
09:45-10:00	0	0	0	0	3	3	3
11:30-11:45	0	1	1	1	0	1	2
11:45-12:00	0	0	0	0	1	1	1
12:00-12:15	0	0	0	0	0	0	0
12:15-12:30	0	0	0	0	2	2	2
12:30-12:45	0	0	0	0	0	0	0
12:45-13:00	1	0	1	1	2	3	4
13:00-13:15	0	0	0	1	0	1	1
13:15-13:30	0	0	0	0	0	0	0
15:00-15:15	1	1	2	0	2	2	4
15:15-15:30	0	1	1	1	0	1	2
15:30-15:45	0	0	0	1	2	3	3
15:45-16:00	0	0	0	4	0	4	4
16:00-16:15	0	0	0	2	0	2	2
16:15-16:30	0	0	0	1	0	1	1
16:30-16:45	0	0	0	0	1	1	1
16:45-17:00	1	0	1	1	1	2	3
17:00-17:15	0	0	0	0	0	0	0
17:15-17:30	0	0	0	1	2	3	3
17:30-17:45	0	0	0	0	1	1	1
17:45-18:00	1	0	1	1	0	1	2
08:45-09:00	0	0	0	0	1	1	1
07:00-07:15	0	0	0	1	0	1	1
08:00-08:15	0	0	0	2	0	2	2
07:15-07:30	0	0	0	0	0	0	0
07:30-07:45	0	1	1	1	0	1	2
07:45-08:00	0	0	0	1	0	1	1
08:15-08:30	0	0	0	1	0	1	1
08:30-08:45	1	0	1	1	1	2	3
<b>Total</b>	<b>5</b>	<b>4</b>	<b>9</b>	<b>26</b>	<b>19</b>	<b>45</b>	<b>54</b>



# Transportation Services - Traffic Services

## Turning Movement Count - Study Results

### POULIN AVE @ RICHMOND RD

**Survey Date:** Thursday, August 11, 2016

**WO No:** 36168

**Start Time:** 07:00

**Device:** Miovision

### Full Study Pedestrian Volume

POULIN AVE

RICHMOND RD

Time Period	NB Approach (E or W Crossing)	SB Approach (E or W Crossing)	Total	EB Approach (N or S Crossing)	WB Approach (N or S Crossing)	Total	Grand Total
09:00 09:15	1	0	1	1	0	1	2
09:15 09:30	9	1	10	0	8	8	18
09:30 09:45	1	1	2	0	5	5	7
09:45 10:00	3	1	4	1	3	4	8
11:30 11:45	9	0	9	0	4	4	13
11:45 12:00	5	4	9	0	10	10	19
12:00 12:15	2	5	7	2	2	4	11
12:15 12:30	7	0	7	0	8	8	15
12:30 12:45	4	1	5	3	2	5	10
12:45 13:00	8	6	14	1	3	4	18
13:00 13:15	1	5	6	0	1	1	7
13:15 13:30	3	3	6	2	2	4	10
15:00 15:15	4	5	9	1	2	3	12
15:15 15:30	1	0	1	0	0	0	1
15:30 15:45	2	2	4	0	1	1	5
15:45 16:00	6	3	9	2	2	4	13
16:00 16:15	6	4	10	0	5	5	15
16:15 16:30	9	1	10	0	2	2	12
16:30 16:45	3	0	3	1	0	1	4
16:45 17:00	4	1	5	1	2	3	8
17:00 17:15	0	4	4	0	2	2	6
17:15 17:30	1	9	10	3	1	4	14
17:30 17:45	3	3	6	4	3	7	13
17:45 18:00	2	1	3	1	5	6	9
08:45 09:00	1	3	4	2	0	2	6
07:00 07:15	1	0	1	0	1	1	2
08:00 08:15	2	1	3	2	4	6	9
07:15 07:30	0	2	2	1	2	3	5
07:30 07:45	2	2	4	1	2	3	7
07:45 08:00	0	0	0	0	1	1	1
08:15 08:30	1	3	4	2	2	4	8
08:30 08:45	2	4	6	2	2	4	10
<b>Total</b> .....	<b>103</b>	<b>75</b>	<b>178</b>	<b>33</b>	<b>87</b>	<b>120</b>	<b>298</b>





# Transportation Services - Traffic Services

## Turning Movement Count - Study Results

### POULIN AVE @ RICHMOND RD

**Survey Date:** Thursday, August 11, 2016

**WO No:** 36168

**Start Time:** 07:00

**Device:** Miovision

### Full Study Heavy Vehicles

#### POULIN AVE

#### RICHMOND RD

Northbound

Southbound

Eastbound

Westbound

Time Period	Northbound			N TOT	Southbound			S TOT	STR TOT	Eastbound			E TOT	Westbound			W TOT	STR TOT	Grand Total	
	LT	ST	RT		LT	ST	RT			LT	ST	RT		LT	ST	RT				
09:00	09:15	0	0	0	0	4	0	2	6	6	4	4	0	8	0	3	2	5	13	19
09:15	09:30	0	0	0	0	2	0	1	3	3	3	1	0	4	0	5	0	5	9	12
09:30	09:45	0	0	0	0	1	0	1	2	2	0	9	0	9	0	2	2	4	13	15
09:45	10:00	0	0	0	0	2	0	1	3	3	0	6	0	6	0	8	1	9	15	18
11:30	11:45	0	0	0	0	2	0	1	3	3	0	5	0	5	0	3	2	5	10	13
11:45	12:00	0	0	0	0	0	0	1	1	1	2	5	0	7	0	6	0	6	13	14
12:00	12:15	0	0	0	0	4	0	0	4	4	2	3	0	5	0	8	1	9	14	18
12:15	12:30	0	0	0	0	2	0	1	3	3	0	3	0	3	0	2	1	3	6	9
12:30	12:45	0	1	0	1	1	0	3	4	5	2	2	0	4	0	4	6	10	14	19
12:45	13:00	0	0	0	0	2	0	2	4	4	3	3	0	6	0	3	1	4	10	14
13:00	13:15	0	0	0	0	2	0	2	4	4	5	3	0	8	0	6	2	8	16	20
13:15	13:30	0	0	0	0	3	0	0	3	3	1	2	0	3	0	3	1	4	7	10
15:00	15:15	0	0	0	0	1	0	2	3	3	0	3	0	3	0	4	2	6	9	12
15:15	15:30	0	0	0	0	2	0	0	2	2	0	1	0	1	0	1	2	3	4	6
15:30	15:45	0	0	0	0	1	0	1	2	2	2	2	0	4	0	1	1	2	6	8
15:45	16:00	0	0	0	0	0	0	0	0	0	1	2	0	3	0	1	2	3	6	6
16:00	16:15	0	0	0	0	1	0	0	1	1	0	3	0	3	0	3	0	3	6	7
16:15	16:30	0	0	0	0	1	0	0	1	1	0	1	0	1	0	5	2	7	8	9
16:30	16:45	0	0	0	0	1	0	0	1	1	1	3	0	4	0	1	2	3	7	8
16:45	17:00	0	0	0	0	2	0	0	2	2	0	1	0	1	0	1	1	2	3	5
17:00	17:15	0	0	0	0	1	0	0	1	1	0	2	0	2	0	3	1	4	6	7
17:15	17:30	0	0	0	0	1	0	0	1	1	0	1	0	1	0	2	3	5	6	7
17:30	17:45	0	0	0	0	1	0	0	1	1	0	3	0	3	0	2	2	4	7	8
17:45	18:00	0	0	0	0	1	0	0	1	1	0	2	0	2	0	2	2	4	6	7
08:45	09:00	0	0	0	0	3	0	1	4	4	1	4	0	5	0	1	1	2	7	11
07:00	07:15	0	0	0	0	2	0	0	2	2	3	7	0	10	0	2	2	4	14	16
08:00	08:15	0	0	1	1	1	0	2	3	4	0	2	0	2	0	4	1	5	7	11
07:15	07:30	0	0	0	0	2	0	0	2	2	0	6	0	6	0	1	2	3	9	11
07:30	07:45	0	0	0	0	2	0	1	3	3	1	8	0	9	0	5	2	7	16	19
07:45	08:00	0	0	0	0	1	0	0	1	1	2	5	0	7	0	3	1	4	11	12
08:15	08:30	0	0	0	0	3	0	1	4	4	0	3	0	3	0	3	0	3	6	10
08:30	08:45	0	0	1	1	2	0	0	2	3	1	11	0	12	0	2	1	3	15	18
Total:	None	0	1	2	3	54	0	23	77	80	34	116	0	150	0	100	49	149	299	379



# Transportation Services - Traffic Services

## Turning Movement Count - Study Results

### POULIN AVE @ RICHMOND RD

**Survey Date:** Thursday, August 11, 2016

**WO No:** 36168

**Start Time:** 07:00

**Device:** Miovision

### Full Study 15 Minute U-Turn Total

POULIN AVE

RICHMOND RD

Time Period	Northbound U-Turn Total	Southbound U-Turn Total	Eastbound U-Turn Total	Westbound U-Turn Total	Total
09:00 - 09:15	0	0	1	0	1
09:15 - 09:30	0	0	0	0	0
09:30 - 09:45	0	0	1	0	1
09:45 - 10:00	0	0	0	0	0
11:30 - 11:45	0	0	0	0	0
11:45 - 12:00	0	0	0	0	0
12:00 - 12:15	0	0	0	0	0
12:15 - 12:30	0	0	0	0	0
12:30 - 12:45	0	0	2	0	2
12:45 - 13:00	0	0	1	0	1
13:00 - 13:15	0	0	0	0	0
13:15 - 13:30	0	0	0	0	0
15:00 - 15:15	0	0	0	0	0
15:15 - 15:30	0	0	0	0	0
15:30 - 15:45	0	0	1	0	1
15:45 - 16:00	0	0	1	0	1
16:00 - 16:15	0	0	0	0	0
16:15 - 16:30	0	1	0	0	1
16:30 - 16:45	1	0	1	0	2
16:45 - 17:00	0	0	1	0	1
17:00 - 17:15	0	0	0	0	0
17:15 - 17:30	0	0	0	0	0
17:30 - 17:45	0	0	0	0	0
17:45 - 18:00	0	0	0	0	0
08:45 - 09:00	0	0	1	0	1
07:00 - 07:15	0	0	0	0	0
08:00 - 08:15	0	0	0	0	0
07:15 - 07:30	0	0	0	0	0
07:30 - 07:45	0	0	0	0	0
07:45 - 08:00	0	0	0	0	0
08:15 - 08:30	0	0	0	0	0
08:30 - 08:45	0	0	0	0	0
<b>Total</b>	1	1	10	0	12

# Traffic Signal Timing

City of Ottawa, Transportation Services Department

## Traffic Signal Operations Unit

<b>Intersection:</b>	<b>Main:</b> Richmond	<b>Side:</b> Croydon
<b>Controller:</b>	<b>MS-3200</b>	<b>TSD:</b> 5197
<b>Author:</b>	Matthew Anderson	<b>Date:</b> 19-Sep-2019

## Existing Timing Plans†

	Plan					Ped Minimum Time		
	AM Peak 1	Off Peak 2	PM Peak 3	Night 4	Weekend 5	Walk	DW	A+R
<b>Cycle</b>	70	70	85	65	70			
<b>Offset</b>	40	28	71	X	32			
EB Thru	39	39	54	34	39	7	13	3.3+3.1
WB Thru	39	39	54	34	39	7	13	3.3+3.1
NB Thru	31	31	31	31	31	7	18	3.3+2.8
SB Thru	31	31	31	31	31	7	18	3.3+2.8

## Phasing Sequence‡

Plan:

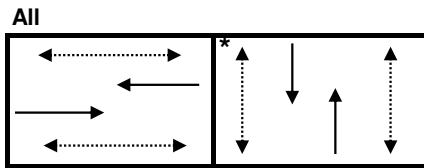

## Schedule

Weekday		Saturday		Sunday	
Time	Plan	Time	Plan	Time	Plan
0:15	4	0:15	4	0:15	4
6:30	1	6:30	2	9:10	2
9:30	2	9:10	5	20:00	4
15:00	3	20:00	4		
18:30	2				
21:30	4				

## Notes

†: Time for each direction includes amber and all red intervals

‡: Start of first phase should be used as reference point for offset

Asterisk (\*) Indicates actuated phase

(fp): Fully Protected Left Turn

◄.....► Pedestrian signal

Cost is \$57.63 (\$51 + HST)

# Traffic Signal Timing

City of Ottawa, Transportation Services Department

## Traffic Signal Operations Unit

<b>Intersection:</b>	<b>Main:</b> Carling	<b>Side:</b> Alpine
<b>Controller:</b>	<b>MS-3200A</b>	<b>TSD:</b> 5385
<b>Author:</b>	Matthew Anderson	<b>Date:</b> 19-Sep-2019

### Existing Timing Plans†

	Plan					Ped Minimum Time		
	Off Peak 2	PM Peak 3	Night 4	Weekend 5	AM Peak 47	Walk	DW	A+R
<b>Cycle</b>	100	130	80	100	130			
<b>Offset</b>	81	9	X	79	40			
EB Thru	46	75	37	46	76	16	12	3.7+2.2
WB Thru	46	75	37	46	87	16	12	3.7+2.2
NB Thru	43	43	43	43	43	7	29	3.3+3.4
SB Thru	43	43	43	43	43	7	29	3.3+3.4
EB Left	11	12	-	11	-	-	-	3.7+2.2
WB Left	11	12	-	11	11	-	-	3.7+2.2

### Phasing Sequence‡

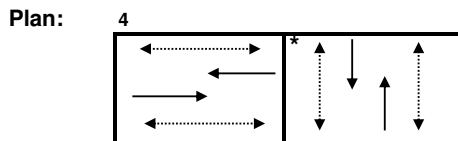
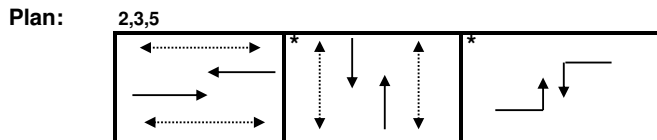
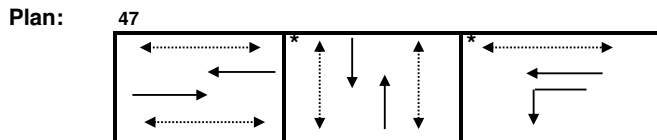

### Schedule

Weekday		Weekend	
Time	Plan	Time	Plan
0:15	4	0:15	4
6:30	47	7:00	2
9:30	2	9:10	5
15:00	3	18:30	2
18:30	2	22:00	4
21:30	4		

### Notes

- †: Time for each direction includes amber and all red intervals
- ‡: Start of first phase should be used as reference point for offset
- Asterisk (\*) Indicates actuated phase
- (fp): Fully Protected Left Turn
- ◄.....► Pedestrian signal

Cost is \$57.63 (\$51 + HST)

# Traffic Signal Timing

City of Ottawa, Transportation Services Department

## Traffic Signal Operations Unit

<b>Intersection:</b>	Main: Carling	Side: Croydon
<b>Controller:</b>	MS-3200	<b>TSD:</b> 5632
<b>Author:</b>	Matthew Anderson	<b>Date:</b> 19-Sep-2019

### Existing Timing Plans<sup>†</sup>

Plan	Plan					Ped Minimum Time		
	Off Peak 2	PM Peak 3	Night 4	Weekend 5	AM Peak 47	Walk	DW	A+R
<b>Cycle</b>	100	130	80	100	130			
<b>Offset</b>	80	18	X	83	45			
EB Thru	62	92	42	62	92	-	-	3.7+2.2
WB Thru	50	78	42	50	78	7	16	3.7+2.2
SB Thru	38	38	38	38	38	21	10	3.3+3.0
EB Left	12	14	-	12	14	-	-	3.7+2.2

### Phasing Sequence<sup>‡</sup>

Plans: 2, 3, 5 & 47

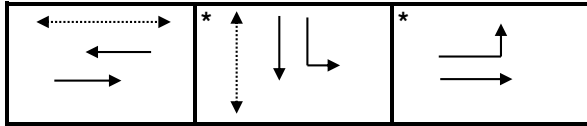

Plans: 4

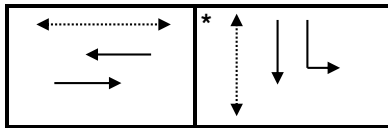

### Schedule

Weekday		Saturday		Sunday	
Time	Plan	Time	Plan	Time	Plan
0:15	4	0:15	4	0:15	4
6:30	47	7:00	2	7:00	2
9:30	2	9:10	5	9:10	5
15:00	3	18:30	2	18:30	2
18:30	2	22:00	4	22:00	4
21:30	4				

### Notes

<sup>†</sup>: Time for each direction includes amber and all red intervals

<sup>‡</sup>: Start of first phase should be used as reference point for offset

Asterisk (\*) Indicates actuated phase

(fp): Fully Protected Left Turn

←.....→ Pedestrian signal

Cost is \$57.63 (\$51 + HST)

# Traffic Signal Timing

City of Ottawa, Transportation Services Department

Traffic Signal Operations Unit

<b>Intersection:</b>	<b>Main:</b> Carling	<b>Side:</b> Richmond
<b>Controller:</b>	<b>ATC 3</b>	<b>TSD:</b> 5247
<b>Author:</b>	Matthew Anderson	<b>Date:</b> 04-May-2020

## Existing Timing Plans†

	Plan					Ped Minimum Time		
	AM Peak 1	Off Peak 2	PM Peak 3	Night 4	Weekend 5	Walk	DW	A+R
<b>Cycle</b>	130	100	130	105	100			
<b>Offset</b>	47	78	104	X	78			
EB Thru	47	41	48	46	41	10	21	3.7+2.1
WB Thru	55	38	59	43	38	10	21	3.7+2.1
WB Left (fp)	11	-	11	-	-	-	-	3.7+2.3
NB Thru	46	46	46	46	46	10	29	3.7+3.3
SB Thru	46	46	46	46	46	10	29	3.7+3.3
EB Left (fp)	29	16	25	16	16	-	-	3.7+2.3
WB Left (fp)	26	13	25	13	13	-	-	3.7+2.3

## Phasing Sequence‡

Plan: 2,4,5

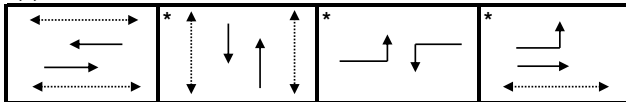

Plan: 1

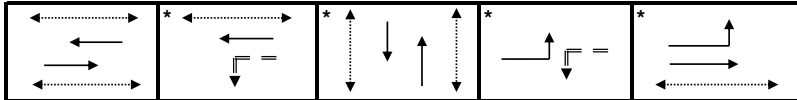

Plan: 3

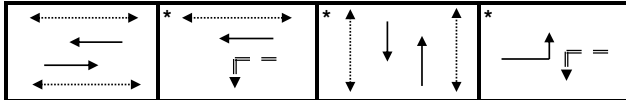

- Notes:**
- 1) The NB Left and Right Turns are Prohibited
  - 2) The SB Left Turn is Prohibited
  - 3) The EB U Turn is Prohibited
  - 4) The WB Left Turn is Prohibited with Buses Excepted

## Schedule

Weekday		Weekend	
Time	Plan	Time	Plan
0:15	4	0:15	4
6:30	1	7:00	2
9:30	2	9:10	5
15:00	3	18:30	2
18:30	2	22:00	6
21:30	4		

## NOTES

†: Time for each direction includes amber and all red intervals  
 ‡: Start of first phase should be used as reference point for offset  
 Asterisk (\*) Indicates actuated phase  
 (fp): Fully Protected Left Turn  
 ◀.....▶ Pedestrian signal  
 == => Transit signal  
 Cost is \$58.78 (\$52.02 + HST)

# Traffic Signal Timing

City of Ottawa, Transportation Services Department

## Traffic Signal Operations Unit

<b>Intersection:</b>	<i>Main:</i> Richmond	<i>Side:</i> Poulin
<b>Controller:</b>	<b>ATC 3</b>	<b>TSD: 5611</b>
<b>Author:</b>	Matthew Anderson	<b>Date:</b> 04-May-2020

### Existing Timing Plans†

	Plan					Ped Minimum Time		
	AM Peak 1	Off Peak 2	PM Peak 3	Night 4	Weekend 5	Walk	DW	A+R
<b>Cycle</b>	130	75	90	70	100			
<b>Offset</b>	90	52	13	X	35			
EB Thru	96	41	56	36	66	7	17	3.3+3.0
WB Thru	96	41	41	36	66	7	17	3.3+3.0
NB Thru	34	34	34	34	34	7	20	3.3+2.9
SB Thru	34	34	34	34	34	7	20	3.3+2.9
EB Left	-	-	15	-	-	-	-	3.3+3.0

### Phasing Sequence‡

Plan: All

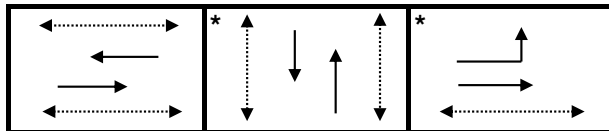

**Notes:** 1) The WB Left Turn is Prohibited

### Schedule

Weekday		Weekend	
Time	Plan	Time	Plan
0:15	4	0:15	4
6:30	1	7:00	2
9:30	2	9:10	5
15:00	3	18:30	2
18:30	2	22:00	6
21:30	4		

### Notes

- †: Time for each direction includes amber and all red intervals
- ‡: Start of first phase should be used as reference point for offset
- Asterisk (\*) Indicates actuated phase
- (fp): Fully Protected Left Turn
- ◄.....► Pedestrian signal

Cost is \$58.78 (\$52.02 + HST)



# City Operations - Transportation Services

## Collision Details Report - Public Version

**From:** January 1, 2014    **To:** December 31, 2018

**Location:** ALPINE AVE @ CARLING AVE

**Traffic Control:** Traffic signal

**Total Collisions:** 48

Date/Day/Time	Environment	Impact Type	Classification	Surface Cond'n	Veh. Dir	Vehicle Manoeuvre	Vehicle type	First Event	No. Ped
2014-Feb-01, Sat,22:59	Snow	Rear end	P.D. only	Loose snow	West	Unknown	Automobile, station wagon	Other motor vehicle	
					West	Stopped	Automobile, station wagon	Other motor vehicle	
2014-Mar-16, Sun,16:29	Clear	Angle	P.D. only	Dry	East	Going ahead	Automobile, station wagon	Other motor vehicle	
					South	Going ahead	Automobile, station wagon	Other motor vehicle	
2014-Apr-08, Tue,17:00	Clear	Rear end	P.D. only	Dry	Unknown	Going ahead	Pick-up truck	Other motor vehicle	
					Unknown	Stopped	Automobile, station wagon	Other motor vehicle	
2014-Apr-21, Mon,18:00	Clear	Rear end	P.D. only	Dry	East	Slowing or stopping	Automobile, station wagon	Other motor vehicle	
					East	Stopped	Automobile, station wagon	Other motor vehicle	
2014-Feb-01, Sat,15:10	Snow	Turning movement	P.D. only	Loose snow	West	Turning left	Pick-up truck	Other motor vehicle	
					East	Going ahead	Automobile, station wagon	Other motor vehicle	
2014-Jun-17, Tue,21:10	Rain	Turning movement	P.D. only	Wet	East	Turning left	Truck - closed	Other motor vehicle	



					West	Going ahead	Automobile, station wagon	Other motor vehicle
2014-Jul-23, Wed, 15:45	Clear	Sideswipe	P.D. only	Dry	East	Changing lanes	Pick-up truck	Other motor vehicle
					East	Going ahead	Pick-up truck	Other motor vehicle
2014-Sep-06, Sat, 09:56	Rain	Rear end	Non-fatal injury	Wet	East	Slowing or stopping	Pick-up truck	Other motor vehicle
					East	Stopped	Automobile, station wagon	Other motor vehicle
2014-Nov-15, Sat, 12:58	Clear	Turning movement	P.D. only	Dry	East	Turning left	Passenger van	Other motor vehicle
					West	Going ahead	Automobile, station wagon	Other motor vehicle
2014-Dec-11, Thu, 15:31	Snow	Angle	Non-fatal injury	Slush	West	Going ahead	Pick-up truck	Other motor vehicle
					South	Going ahead	Automobile, station wagon	Other motor vehicle
2015-Oct-10, Sat, 10:11	Clear	Turning movement	Non-fatal injury	Dry	East	Turning left	Passenger van	Other motor vehicle
					West	Going ahead	Pick-up truck	Other motor vehicle
2015-Mar-17, Tue, 12:15	Clear	Angle	P.D. only	Dry	West	Going ahead	Automobile, station wagon	Other motor vehicle
					South	Going ahead	Automobile, station wagon	Other motor vehicle
2015-Jul-14, Tue, 17:13	Clear	Rear end	Non-fatal injury	Dry	West	Going ahead	Automobile, station wagon	Other motor vehicle
					West	Stopped	Automobile, station wagon	Other motor vehicle

					West	Stopped	Passenger van	Other motor vehicle	
					West	Stopped	Pick-up truck	Other motor vehicle	
2015-Jun-10, Wed,07:20	Clear	Angle	P.D. only	Dry	South	Going ahead	Pick-up truck	Other motor vehicle	
					West	Turning right	Automobile, station wagon	Other motor vehicle	
2016-Mar-04, Fri,17:30	Clear	Turning movement	P.D. only	Dry	East	Turning left	Automobile, station wagon	Other motor vehicle	
					West	Going ahead	Pick-up truck	Other motor vehicle	
2016-Sep-16, Fri,16:27	Clear	Angle	Non-fatal injury	Dry	West	Going ahead	Bicycle	Other motor vehicle	
					North	Turning right	Automobile, station wagon	Cyclist	
2016-Oct-25, Tue,16:56	Clear	Angle	Non-fatal injury	Dry	East	Going ahead	Pick-up truck	Other motor vehicle	1
					South	Going ahead	Pick-up truck	Other motor vehicle	
2015-Dec-17, Thu,16:55	Rain	Turning movement	P.D. only	Wet	East	Turning left	Automobile, station wagon	Other motor vehicle	
					West	Going ahead	Pick-up truck	Other motor vehicle	
					South	Stopped	Pick-up truck	Other motor vehicle	
2016-Aug-19, Fri,12:09	Clear	Angle	P.D. only	Dry	West	Going ahead	Automobile, station wagon	Other motor vehicle	
					South	Turning left	Automobile, station wagon	Other motor vehicle	

2016-Mar-11, Fri,15:32	Clear	Rear end	P.D. only	Dry	West	Changing lanes	Pick-up truck	Other motor vehicle
					West	Going ahead	Pick-up truck	Other motor vehicle

2016-Jun-28, Tue,15:55	Clear	Rear end	P.D. only	Dry	West	Slowing or stopping	Passenger van	Other motor vehicle
					West	Stopped	Pick-up truck	Other motor vehicle

2017-Nov-12, Sun,16:39	Clear	Angle	P.D. only	Dry	North	Going ahead	Automobile, station wagon	Other motor vehicle
					West	Going ahead	Automobile, station wagon	Other motor vehicle

2017-Oct-05, Thu,16:26	Clear	Turning movement	P.D. only	Dry	East	Turning left	Automobile, station wagon	Other motor vehicle
					West	Going ahead	Automobile, station wagon	Other motor vehicle
					South	Stopped	Automobile, station wagon	Other motor vehicle

2017-Aug-21, Mon,19:08	Clear	Rear end	P.D. only	Dry	East	Slowing or stopping	Automobile, station wagon	Other motor vehicle
					East	Stopped	Automobile, station wagon	Other motor vehicle
					East	Stopped	Automobile, station wagon	Other motor vehicle
					East	Stopped	Automobile, station wagon	Other motor vehicle

2017-Jan-31, Tue,16:56	Clear	Turning movement	P.D. only	Dry	East	Turning left	Automobile, station wagon	Other motor vehicle
					West	Going ahead	Automobile, station wagon	Other motor vehicle

2017-Jan-13, Fri,15:28	Clear	Rear end	P.D. only	Dry	West	Slowing or stopping	Automobile, station wagon	Other motor vehicle
					West	Stopped	Automobile, station wagon	Other motor vehicle
2016-Dec-09, Fri,06:50	Clear	Rear end	P.D. only	Ice	East	Slowing or stopping	Pick-up truck	Other motor vehicle
					East	Stopped	Automobile, station wagon	Other motor vehicle
2016-Sep-29, Thu,23:58	Clear	Turning movement	P.D. only	Dry	West	Turning right	Unknown	Other motor vehicle
					West	Going ahead	Municipal transit bus	Other motor vehicle
2016-Dec-09, Fri,06:39	Clear	Rear end	P.D. only	Ice	East	Slowing or stopping	Automobile, station wagon	Other motor vehicle
					East	Stopped	Pick-up truck	Other motor vehicle
2017-Mar-03, Fri,13:41	Clear	Angle	P.D. only	Dry	West	Going ahead	Automobile, station wagon	Other motor vehicle
					South	Turning left	Automobile, station wagon	Other motor vehicle
2017-May-03, Wed,10:50	Clear	Angle	P.D. only	Dry	West	Going ahead	Automobile, station wagon	Other motor vehicle
					North	Going ahead	Automobile, station wagon	Other motor vehicle
2017-May-19, Fri,12:10	Clear	Rear end	Non-fatal injury	Dry	West	Going ahead	Automobile, station wagon	Other motor vehicle
					West	Stopped	Automobile, station wagon	Other motor vehicle
2017-Jun-28, Wed,18:50	Rain	Rear end	P.D. only	Wet	West	Slowing or stopping	Automobile, station wagon	Other motor vehicle

					West	Stopped	Automobile, station wagon	Other motor vehicle
2017-Jul-21, Fri,17:26	Clear	Sideswipe	P.D. only	Dry	West	Changing lanes	Automobile, station wagon	Other motor vehicle
					West	Going ahead	Automobile, station wagon	Other motor vehicle
2017-Nov-21, Tue,16:47	Clear	Sideswipe	Non-fatal injury	Dry	East	Changing lanes	Automobile, station wagon	Other motor vehicle
					East	Going ahead	Bus (other)	Other motor vehicle
2017-Nov-08, Wed,15:40	Clear	Rear end	P.D. only	Dry	West	Going ahead	Automobile, station wagon	Other motor vehicle
					West	Slowing or stopping	Automobile, station wagon	Other motor vehicle
					West	Stopped	Automobile, station wagon	Other motor vehicle
2018-Feb-24, Sat,09:27	Clear	Rear end	P.D. only	Dry	East	Changing lanes	Automobile, station wagon	Other motor vehicle
					East	Going ahead	Automobile, station wagon	Other motor vehicle
2018-May-03, Thu,17:45	Rain	Angle	P.D. only	Wet	East	Reversing	Automobile, station wagon	Other motor vehicle
					North	Going ahead	Automobile, station wagon	Other motor vehicle
2018-May-28, Mon,15:58	Clear	Turning movement	P.D. only	Dry	East	Turning left	Automobile, station wagon	Other motor vehicle
					West	Going ahead	Automobile, station wagon	Other motor vehicle
2018-Jul-20, Fri,08:35	Clear	Turning movement	P.D. only	Dry	East	Turning left	Automobile, station wagon	Other motor vehicle

					West	Going ahead	Automobile, station wagon	Other motor vehicle
2018-Nov-29, Thu,14:24	Clear	Turning movement	P.D. only	Dry	South	Turning left	Automobile, station wagon	Other motor vehicle
					North	Going ahead	Automobile, station wagon	Other motor vehicle
2018-Nov-28, Wed,11:12	Clear	Turning movement	P.D. only	Dry	West	Turning left	Automobile, station wagon	Other motor vehicle
					East	Going ahead	Automobile, station wagon	Other motor vehicle
2018-Nov-30, Fri,22:07	Clear	Turning movement	P.D. only	Dry	West	Going ahead	Unknown	Other motor vehicle
					West	Turning right	Police vehicle	Other motor vehicle
2018-Sep-21, Fri,17:10	Rain	Sideswipe	P.D. only	Wet	West	Changing lanes	Passenger van	Other motor vehicle
					West	Going ahead	Automobile, station wagon	Other motor vehicle
2018-Sep-04, Tue,07:38	Clear	Turning movement	P.D. only	Dry	North	Turning right	Automobile, station wagon	Other motor vehicle
					North	Turning left	Pick-up truck	Other motor vehicle
					North	Stopped	Automobile, station wagon	Other motor vehicle
2018-Aug-20, Mon,16:21	Clear	Rear end	P.D. only	Dry	West	Going ahead	Pick-up truck	Other motor vehicle
					West	Stopped	Automobile, station wagon	Other motor vehicle
					West	Stopped	Automobile, station wagon	Other motor vehicle

2018-Oct-12, Fri,15:30	Clear	Turning movement	P.D. only	Dry	East	Turning left	Automobile, station wagon	Other motor vehicle
					West	Going ahead	Automobile, station wagon	Other motor vehicle

2018-Jul-16, Mon,16:07	Clear	Turning movement	P.D. only	Dry	East	Turning left	Automobile, station wagon	Other motor vehicle
					West	Going ahead	Automobile, station wagon	Other motor vehicle

**Location:** CARLING AVE @ CROYDON AVE

**Traffic Control:** Traffic signal

**Total Collisions:** 44

Date/Day/Time	Environment	Impact Type	Classification	Surface Cond'n	Veh. Dir	Vehicle Manoeuvre	Vehicle type	First Event	No. Ped
2014-Jan-22, Wed,16:50	Clear	Turning movement	P.D. only	Dry	East	Turning left	Automobile, station wagon	Other motor vehicle	
					West	Going ahead	Automobile, station wagon	Other motor vehicle	
2014-Jan-17, Fri,10:55	Snow	Angle	P.D. only	Wet	East	Going ahead	Automobile, station wagon	Other motor vehicle	
					South	Turning left	Automobile, station wagon	Other motor vehicle	
2014-Feb-17, Mon,16:32	Clear	Angle	P.D. only	Dry	West	Going ahead	Automobile, station wagon	Other motor vehicle	
					South	Turning left	Automobile, station wagon	Other motor vehicle	
2014-Mar-29, Sat,18:01	Clear	SMV other	P.D. only	Dry	South	Turning left	Automobile, station wagon	Pole (utility, power)	
2014-Mar-08, Sat,17:45	Clear	Angle	P.D. only	Dry	West	Going ahead	Automobile, station wagon	Other motor vehicle	
					South	Turning left	Automobile, station wagon	Other motor vehicle	

2014-Mar-21, Fri,06:44	Clear	Turning movement	P.D. only	Wet	East	Turning left	Automobile, station wagon	Other motor vehicle	
					West	Going ahead	Pick-up truck	Other motor vehicle	
2014-Apr-29, Tue,17:42	Clear	Rear end	P.D. only	Dry	West	Going ahead	Automobile, station wagon	Other motor vehicle	
					West	Turning right	Pick-up truck	Other motor vehicle	
2014-May-15, Thu,15:00	Clear	Sideswipe	P.D. only	Dry	East	Changing lanes	Automobile, station wagon	Other motor vehicle	
					East	Changing lanes	Pick-up truck	Other motor vehicle	
2014-May-14, Wed,19:00	Clear	Turning movement	P.D. only	Dry	South	Turning left	Automobile, station wagon	Other motor vehicle	
					South	Turning left	Automobile, station wagon	Other motor vehicle	
2014-Jul-18, Fri,15:15	Clear	SMV other	Non-fatal injury	Dry	South	Turning right	Delivery van	Pedestrian	1
2014-Jul-08, Tue,16:51	Clear	Other	P.D. only	Dry	North	Reversing	Pick-up truck	Other motor vehicle	
					South	Stopped	Police vehicle	Other motor vehicle	
2014-Dec-01, Mon,11:45	Clear	Rear end	P.D. only	Dry	West	Going ahead	Automobile, station wagon	Other motor vehicle	
					West	Stopped	Automobile, station wagon	Other motor vehicle	
2015-Feb-20, Fri,08:15	Clear	Rear end	P.D. only	Ice	South	Turning left	Automobile, station wagon	Other motor vehicle	
					South	Turning left	Automobile, station wagon	Other motor vehicle	



2014-Oct-22, Wed,14:03	Clear	Sideswipe	P.D. only	Dry	West	Changing lanes	Automobile, station wagon	Other motor vehicle
					West	Going ahead	Truck and trailer	Other motor vehicle
2015-Apr-29, Wed,20:18	Clear	Turning movement	P.D. only	Dry	East	Turning left	Automobile, station wagon	Other motor vehicle
					West	Going ahead	Automobile, station wagon	Other motor vehicle
2015-Mar-16, Mon,12:10	Clear	Rear end	P.D. only	Dry	West	Going ahead	Passenger van	Other motor vehicle
					West	Stopped	Automobile, station wagon	Other motor vehicle
2016-Mar-13, Sun,11:08	Clear	Turning movement	Non-fatal injury	Dry	West	Going ahead	Automobile, station wagon	Other motor vehicle
					East	Making "U" turn	Automobile, station wagon	Other motor vehicle
2016-Feb-23, Tue,12:49	Clear	Other	P.D. only	Dry	West	Going ahead	Automobile, station wagon	Curb
					East	Turning left	Automobile, station wagon	Other motor vehicle
					South	Stopped	Automobile, station wagon	Other motor vehicle
					South	Stopped	Pick-up truck	Other motor vehicle
2016-Oct-25, Tue,15:51	Clear	Turning movement	P.D. only	Dry	East	Turning left	Pick-up truck	Other motor vehicle
					West	Going ahead	Automobile, station wagon	Other motor vehicle
2016-Jun-22, Wed,18:18	Clear	Rear end	Non-fatal injury	Dry	East	Changing lanes	Automobile, station wagon	Other motor vehicle

					East	Slowing or stopping	Pick-up truck	Other motor vehicle
2015-Oct-12, Mon,13:59	Clear	Rear end	Non-fatal injury	Dry	West	Going ahead	Pick-up truck	Other motor vehicle
					West	Stopped	Automobile, station wagon	Other motor vehicle
2016-Sep-14, Wed,13:20	Clear	Rear end	P.D. only	Dry	West	Going ahead	Automobile, station wagon	Other motor vehicle
					West	Stopped	Automobile, station wagon	Other motor vehicle
2016-May-25, Wed,14:45	Clear	SMV other	P.D. only	Dry	West	Going ahead	Automobile, station wagon	Pole (utility, power)
2016-Jul-06, Wed,15:30	Clear	Sideswipe	P.D. only	Dry	East	Changing lanes	Automobile, station wagon	Other motor vehicle
					East	Turning left	Pick-up truck	Other motor vehicle
2016-Apr-18, Mon,10:14	Clear	Turning movement	P.D. only	Dry	East	Turning left	Automobile, station wagon	Other motor vehicle
					West	Going ahead	Pick-up truck	Other motor vehicle
2016-Oct-06, Thu,16:00	Clear	Turning movement	P.D. only	Dry	East	Turning left	Pick-up truck	Other motor vehicle
					West	Going ahead	Automobile, station wagon	Other motor vehicle
2016-Nov-03, Thu,17:42	Clear	Turning movement	Non-fatal injury	Dry	West	Going ahead	Automobile, station wagon	Other motor vehicle
					East	Turning left	Pick-up truck	Other motor vehicle

2017-Sep-15, Fri,19:42	Clear	Turning movement	P.D. only	Dry	East	Making "U" turn	Automobile, station wagon	Other motor vehicle
					West	Going ahead	Automobile, station wagon	Other motor vehicle
2017-Oct-22, Sun,17:01	Clear	Angle	P.D. only	Dry	North	Turning left	Unknown	Other motor vehicle
					East	Going ahead	Pick-up truck	Other motor vehicle
2016-Dec-31, Sat,12:46	Clear	Rear end	P.D. only	Dry	East	Going ahead	Automobile, station wagon	Other motor vehicle
					East	Stopped	Automobile, station wagon	Other motor vehicle
2017-Mar-08, Wed,15:28	Clear	Angle	P.D. only	Dry	South	Turning left	Automobile, station wagon	Other motor vehicle
					East	Going ahead	Automobile, station wagon	Other motor vehicle
2017-Mar-15, Wed,17:42	Snow	Turning movement	Non-fatal injury	Loose snow	East	Turning left	Automobile, station wagon	Other motor vehicle
					West	Going ahead	Automobile, station wagon	Other motor vehicle
2017-Jun-16, Fri,16:17	Clear	Turning movement	P.D. only	Dry	East	Turning left	Automobile, station wagon	Other motor vehicle
					West	Going ahead	Automobile, station wagon	Other motor vehicle
2017-Jul-09, Sun,15:40	Clear	Turning movement	P.D. only	Dry	East	Turning left	Automobile, station wagon	Other motor vehicle
					West	Going ahead	Pick-up truck	Other motor vehicle
2017-Oct-19, Thu,09:58	Clear	Turning movement	P.D. only	Dry	North	Turning right	Unknown	Other motor vehicle

					North	Going ahead	Automobile, station wagon	Other motor vehicle	
2017-Sep-15, Fri,13:25	Clear	Rear end	P.D. only	Dry	West	Slowing or stopping	Pick-up truck	Other motor vehicle	
					West	Slowing or stopping	Passenger van	Other motor vehicle	
2017-Sep-15, Fri,13:59	Clear	Sideswipe	P.D. only	Dry	South	Turning left	Truck and trailer	Other motor vehicle	
					South	Turning left	Pick-up truck	Other motor vehicle	
2017-Dec-05, Tue,11:15	Clear	Sideswipe	P.D. only	Dry	West	Changing lanes	Automobile, station wagon	Other motor vehicle	
					West	Changing lanes	Automobile, station wagon	Other motor vehicle	
2018-Jan-18, Thu,18:44	Clear	SMV other	Non-fatal injury	Dry	South	Turning left	Automobile, station wagon	Pedestrian	1
2018-Oct-18, Thu,15:39	Clear	Angle	P.D. only	Dry	East	Going ahead	Pick-up truck	Other motor vehicle	
					South	Turning left	Automobile, station wagon	Other motor vehicle	
2018-Sep-07, Fri,19:10	Clear	Turning movement	Non-fatal injury	Dry	West	Going ahead	Automobile, station wagon	Other motor vehicle	
					East	Turning left	Automobile, station wagon	Other motor vehicle	
2018-Oct-04, Thu,09:00	Rain	Angle	Non-fatal injury	Wet	West	Going ahead	Passenger van	Other motor vehicle	
					South	Turning left	Automobile, station wagon	Other motor vehicle	

2018-Nov-14, Wed,10:27	Clear	Sideswipe	Non-fatal injury	Wet	South	Changing lanes	Automobile, station wagon	Other motor vehicle
					South	Turning left	Automobile, station wagon	Other motor vehicle

2018-Nov-14, Wed,18:21	Clear	SMV other	Non-fatal injury	Dry	North	Turning left	Unknown	Pedestrian	1
------------------------	-------	-----------	------------------	-----	-------	--------------	---------	------------	---

**Location:** CROYDON AVE @ RICHMOND RD

**Traffic Control:** Traffic signal

**Total Collisions:** 28

Date/Day/Time	Environment	Impact Type	Classification	Surface Cond'n	Veh. Dir	Vehicle Manoeuver	Vehicle type	First Event	No. Ped
2014-Feb-02, Sun,12:00	Clear	Rear end	P.D. only	Wet	West	Going ahead	Automobile, station wagon	Other motor vehicle	
					West	Stopped	Automobile, station wagon	Other motor vehicle	
2014-Jan-11, Sat,06:23	Rain	SMV other	P.D. only	Ice	East	Turning right	Automobile, station wagon	Pole (utility, power)	
2014-Jul-24, Thu,15:45	Clear	Rear end	P.D. only	Dry	West	Going ahead	Automobile, station wagon	Other motor vehicle	
					West	Stopped	Automobile, station wagon	Other motor vehicle	
					West	Stopped	Pick-up truck	Other motor vehicle	
2015-Feb-05, Thu,13:01	Clear	Turning movement	P.D. only	Dry	North	Turning left	Passenger van	Other motor vehicle	
					South	Going ahead	Unknown	Other motor vehicle	
2014-Sep-03, Wed,15:30	Clear	Angle	P.D. only	Dry	East	Turning left	Passenger van	Other motor vehicle	
					North	Going ahead	Automobile, station wagon	Other motor vehicle	

2015-Jul-04, Sat,18:16	Clear	Rear end	P.D. only	Dry	East	Going ahead	Automobile, station wagon	Other motor vehicle	
					East	Slowing or stopping	Automobile, station wagon	Other motor vehicle	
					East	Slowing or stopping	Automobile, station wagon	Other motor vehicle	
2014-Nov-20, Thu,18:31	Clear	Rear end	P.D. only	Dry	West	Going ahead	Automobile, station wagon	Other motor vehicle	
					West	Slowing or stopping	Automobile, station wagon	Other motor vehicle	
2014-Jun-12, Thu,14:52	Clear	SMV other	Non-fatal injury	Dry	North	Turning left	Pick-up truck	Pedestrian	1
2015-Mar-09, Mon,15:15	Clear	Other	P.D. only	Dry	East	Reversing	School bus	Other motor vehicle	
					West	Stopped	Automobile, station wagon	Other motor vehicle	
2016-Sep-01, Thu,16:02	Clear	Rear end	P.D. only	Dry	West	Unknown	Automobile, station wagon	Other motor vehicle	
					West	Stopped	Automobile, station wagon	Other motor vehicle	
2015-Oct-22, Thu,16:50	Clear	Rear end	P.D. only	Dry	West	Going ahead	Automobile, station wagon	Other motor vehicle	
					West	Stopped	Automobile, station wagon	Other motor vehicle	
2015-Dec-05, Sat,17:52	Clear	Rear end	P.D. only	Dry	East	Going ahead	Automobile, station wagon	Other motor vehicle	
					East	Stopped	Automobile, station wagon	Other motor vehicle	
2016-Feb-17, Wed,19:39	Clear	Rear end	Non-fatal injury	Ice	East	Going ahead	Automobile, station wagon	Other motor vehicle	

					East	Stopped	Automobile, station wagon	Other motor vehicle
					North	Turning left	Automobile, station wagon	Other motor vehicle
2016-May-28, Sat,14:02	Clear	Turning movement	Non-fatal injury	Dry	South	Turning left	Automobile, station wagon	Cyclist
					North	Going ahead	Bicycle	Other motor vehicle
2016-Mar-17, Thu,18:31	Clear	Angle	P.D. only	Dry	North	Going ahead	Automobile, station wagon	Other motor vehicle
					East	Going ahead	Pick-up truck	Other motor vehicle
2017-Jan-07, Sat,14:21	Clear	Angle	P.D. only	Dry	East	Turning right	Automobile, station wagon	Other motor vehicle
					South	Going ahead	Automobile, station wagon	Other motor vehicle
2017-Oct-24, Tue,20:28	Clear	Turning movement	P.D. only	Dry	South	Turning left	Automobile, station wagon	Other motor vehicle
					North	Going ahead	Automobile, station wagon	Other motor vehicle
2016-Nov-24, Thu,19:13	Clear	Rear end	P.D. only	Dry	North	Going ahead	Automobile, station wagon	Other motor vehicle
					North	Stopped	Passenger van	Other motor vehicle
2016-Nov-24, Thu,09:00	Snow	Rear end	P.D. only	Slush	East	Going ahead	Automobile, station wagon	Other motor vehicle
					East	Stopped	Pick-up truck	Other motor vehicle
2017-Jul-21, Fri,13:08	Clear	Turning movement	Non-fatal injury	Dry	North	Turning left	Automobile, station wagon	Other motor vehicle

					South	Going ahead	Automobile, station wagon	Other motor vehicle	
2018-Apr-24, Tue,13:35	Clear	Turning movement	P.D. only	Dry	West	Turning left	Automobile, station wagon	Other motor vehicle	
					East	Going ahead	Automobile, station wagon	Other motor vehicle	
2018-Jun-21, Thu,15:12	Clear	Rear end	P.D. only	Dry	East	Going ahead	Pick-up truck	Other motor vehicle	
					East	Stopped	Automobile, station wagon	Other motor vehicle	
					East	Going ahead	Automobile, station wagon	Other motor vehicle	
2018-Jun-20, Wed,21:30	Clear	Angle	P.D. only	Dry	West	Going ahead	Automobile, station wagon	Other motor vehicle	
					South	Going ahead	Automobile, station wagon	Other motor vehicle	
2018-Sep-28, Fri,17:15	Clear	Turning movement	P.D. only	Dry	North	Turning right	Automobile, station wagon	Other motor vehicle	
					North	Going ahead	Automobile, station wagon	Other motor vehicle	
2018-Oct-25, Thu,08:29	Clear	SMV other	Non-fatal injury	Dry	East	Going ahead	Pick-up truck	Pedestrian	1
2018-Aug-02, Thu,15:32	Clear	Rear end	Non-fatal injury	Dry	North	Slowing or stopping	Automobile, station wagon	Other motor vehicle	
					North	Stopped	Automobile, station wagon	Other motor vehicle	
2018-Aug-06, Mon,13:42	Clear	Angle	P.D. only	Dry	East	Merging	Automobile, station wagon	Other motor vehicle	
					South	Going ahead	Automobile, station wagon	Other motor vehicle	



2018-Dec-21, Fri,05:34	Rain	SMV other	Non-fatal injury	Wet	North	Turning left	Automobile, station wagon	Pedestrian	1
------------------------	------	-----------	------------------	-----	-------	--------------	------------------------------	------------	---

---



# City Operations - Transportation Services

## Collision Details Report - Public Version

**From:** January 1, 2014    **To:** December 31, 2018

**Location:** CARLING AVE @ RICHMOND RD

**Traffic Control:** Traffic signal

**Total Collisions:** 72

Date/Day/Time	Environment	Impact Type	Classification	Surface Cond'n	Veh. Dir	Vehicle Manoeuvre	Vehicle type	First Event	No. Ped
2014-Jan-21, Tue,16:00	Clear	Rear end	P.D. only	Dry	South	Going ahead	Passenger van	Other motor vehicle	
					South	Stopped	Automobile, station wagon	Other motor vehicle	
2014-Mar-13, Thu,08:00	Clear	Rear end	Non-fatal injury	Packed snow	East	Slowing or stopping	Automobile, station wagon	Skidding/sliding	
					East	Stopped	Automobile, station wagon	Other motor vehicle	
2014-Mar-27, Thu,08:37	Clear	Rear end	P.D. only	Wet	East	Slowing or stopping	Automobile, station wagon	Other motor vehicle	
					East	Slowing or stopping	Pick-up truck	Other motor vehicle	
2014-May-14, Wed,13:25	Clear	Rear end	P.D. only	Dry	East	Turning left	Automobile, station wagon	Other motor vehicle	
					East	Turning left	Automobile, station wagon	Other motor vehicle	
2014-May-14, Wed,15:17	Clear	Other	P.D. only	Dry	West	Reversing	Automobile, station wagon	Other motor vehicle	
					East	Turning left	Automobile, station wagon	Other motor vehicle	
2014-Jun-18, Wed,14:30	Clear	Sideswipe	P.D. only	Dry	West	Changing lanes	Pick-up truck	Other motor vehicle	

					West	Going ahead	Pick-up truck	Other motor vehicle
2014-Jun-18, Wed,08:46	Clear	Rear end	P.D. only	Dry	West	Slowing or stopping	Pick-up truck	Other motor vehicle
					West	Stopped	Automobile, station wagon	Other motor vehicle
					West	Stopped	Pick-up truck	Other motor vehicle
2014-May-30, Fri,16:36	Clear	Rear end	P.D. only	Dry	West	Changing lanes	Automobile, station wagon	Other motor vehicle
					West	Slowing or stopping	Automobile, station wagon	Other motor vehicle
2014-Jul-03, Thu,12:10	Clear	Angle	P.D. only	Dry	South	Going ahead	Pick-up truck	Other motor vehicle
					East	Going ahead	Automobile, station wagon	Other motor vehicle
					East	Going ahead	Pick-up truck	Other motor vehicle
2014-Jul-28, Mon,09:30	Clear	Sideswipe	P.D. only	Dry	North	Changing lanes	Automobile, station wagon	Other motor vehicle
					North	Going ahead	Automobile, station wagon	Other motor vehicle
2014-Jul-11, Fri,12:00	Clear	Sideswipe	P.D. only	Dry	South	Going ahead	Truck and trailer	Other motor vehicle
					South	Going ahead	Automobile, station wagon	Other motor vehicle
2014-Sep-12, Fri,11:15	Clear	Other	P.D. only	Dry	West	Reversing	Automobile, station wagon	Other motor vehicle
					East	Stopped	Automobile, station wagon	Other motor vehicle

2014-Dec-01, Mon,18:20	Clear	Sideswipe	P.D. only	Dry	North	Changing lanes	Automobile, station wagon	Other motor vehicle
					North	Going ahead	Automobile, station wagon	Other motor vehicle
2015-Jan-09, Fri,14:37	Clear	Rear end	Non-fatal injury	Wet	East	Slowing or stopping	Pick-up truck	Other motor vehicle
					East	Stopped	Pick-up truck	Other motor vehicle
2015-Feb-21, Sat,17:20	Snow	Other	P.D. only	Loose snow	North	Overtaking	Pick-up truck	Curb
					North	Going ahead	Snow plow	Other motor vehicle
2015-Sep-23, Wed,17:37	Clear	Rear end	Non-fatal injury	Dry	West	Slowing or stopping	Automobile, station wagon	Other motor vehicle
					West	Stopped	Pick-up truck	Other motor vehicle
2015-Feb-23, Mon,20:10	Clear	Rear end	Non-fatal injury	Dry	West	Going ahead	Pick-up truck	Other motor vehicle
					West	Stopped	Automobile, station wagon	Other motor vehicle
2015-Aug-15, Sat,16:28	Clear	Sideswipe	P.D. only	Dry	North	Changing lanes	Automobile, station wagon	Other motor vehicle
					North	Turning right	Automobile, station wagon	Other motor vehicle
2015-Mar-24, Tue,16:53	Clear	Turning movement	Non-fatal injury	Dry	East	Turning left	Police vehicle	Other motor vehicle
					West	Going ahead	Automobile, station wagon	Other motor vehicle
					South	Stopped	Automobile, station wagon	Other motor vehicle

2015-Jan-22, Thu,18:06	Clear	Rear end	Non-fatal injury	Dry	West	Slowing or stopping	Automobile, station wagon	Other motor vehicle
					West	Stopped	Automobile, station wagon	Other motor vehicle
					West	Slowing or stopping	Automobile, station wagon	Other motor vehicle
2015-May-30, Sat,14:08	Rain	Rear end	P.D. only	Wet	West	Slowing or stopping	Automobile, station wagon	Other motor vehicle
					West	Slowing or stopping	Pick-up truck	Other motor vehicle
					West	Stopped	Automobile, station wagon	Other motor vehicle
2015-Aug-06, Thu,23:50	Clear	Rear end	P.D. only	Dry	East	Going ahead	Automobile, station wagon	Other motor vehicle
					East	Stopped	Automobile, station wagon	Other motor vehicle
2016-Aug-01, Mon,16:30	Clear	Angle	Non-fatal injury	Dry	West	Going ahead	Automobile, station wagon	Other motor vehicle
					South	Going ahead	Pick-up truck	Other motor vehicle
2016-May-11, Wed,07:58	Clear	Rear end	P.D. only	Dry	East	Unknown	Unknown	Other motor vehicle
					East	Going ahead	Passenger van	Other motor vehicle
2016-Oct-30, Sun,10:02	Clear	Angle	P.D. only	Dry	South	Going ahead	Automobile, station wagon	Other motor vehicle
					East	Going ahead	Pick-up truck	Other motor vehicle
2015-Dec-10, Thu,21:39	Clear	Rear end	Non-fatal injury	Dry	West	Going ahead	Automobile, station wagon	Other motor vehicle

					West	Stopped	Passenger van	Other motor vehicle
2015-Dec-03, Thu,09:13	Clear	Rear end	P.D. only	Wet	West	Stopped	Automobile, station wagon	Other motor vehicle
					West	Slowing or stopping	Automobile, station wagon	Other motor vehicle
2016-Feb-01, Mon,15:30	Clear	Rear end	P.D. only	Dry	East	Slowing or stopping	Passenger van	Other motor vehicle
					East	Stopped	Automobile, station wagon	Other motor vehicle
2016-Jan-09, Sat,23:14	Clear	Angle	P.D. only	Wet	North	Going ahead	Automobile, station wagon	Other motor vehicle
					East	Going ahead	Automobile, station wagon	Other motor vehicle
2016-Jan-25, Mon,08:58	Clear	Rear end	Non-fatal injury	Slush	North	Going ahead	Automobile, station wagon	Other motor vehicle
					North	Stopped	Pick-up truck	Other motor vehicle
					North	Stopped	Automobile, station wagon	Other motor vehicle
2016-Jan-21, Thu,15:42	Clear	Sideswipe	P.D. only	Dry	West	Changing lanes	Pick-up truck	Other motor vehicle
					West	Going ahead	Automobile, station wagon	Other motor vehicle
2016-Jan-20, Wed,15:23	Clear	Rear end	P.D. only	Wet	West	Changing lanes	Pick-up truck	Other motor vehicle
					West	Stopped	Pick-up truck	Other motor vehicle

2015-Dec-10, Thu,13:00	Clear	Rear end	Non-fatal injury	Dry	North	Turning right	Automobile, station wagon	Other motor vehicle
					North	Turning right	Automobile, station wagon	Other motor vehicle
2015-Dec-23, Wed,22:27	Rain	Angle	P.D. only	Wet	East	Going ahead	Automobile, station wagon	Other motor vehicle
					South	Going ahead	Automobile, station wagon	Other motor vehicle
2016-May-25, Wed,11:54	Clear	SMV other	P.D. only	Dry	East	Turning right	Truck and trailer	Pole (utility, power)
2016-Mar-11, Fri,19:21	Clear	Rear end	Non-fatal injury	Dry	West	Going ahead	Pick-up truck	Other motor vehicle
					West	Stopped	Automobile, station wagon	Other motor vehicle
2016-Mar-09, Wed,10:06	Clear	Rear end	P.D. only	Wet	East	Slowing or stopping	Pick-up truck	Other motor vehicle
					East	Stopped	Pick-up truck	Other motor vehicle
2016-Jun-08, Wed,10:17	Clear	Rear end	P.D. only	Dry	East	Turning right	Pick-up truck	Other motor vehicle
					East	Turning right	Automobile, station wagon	Other motor vehicle
2017-Aug-10, Thu,12:16	Clear	Rear end	P.D. only	Dry	West	Slowing or stopping	Pick-up truck	Other motor vehicle
					West	Stopped	Automobile, station wagon	Other motor vehicle
2017-Feb-12, Sun,14:25	Clear	Rear end	P.D. only	Ice	North	Going ahead	Automobile, station wagon	Other motor vehicle

					North	Stopped	Automobile, station wagon	Other motor vehicle
2017-Feb-06, Mon,13:53	Clear	Other	P.D. only	Wet	North	Reversing	Municipal transit bus	Other motor vehicle
					North	Turning right	Automobile, station wagon	Other motor vehicle
2017-Feb-28, Tue,10:13	Clear	Angle	P.D. only	Dry	North	Going ahead	Automobile, station wagon	Other motor vehicle
					East	Going ahead	Pick-up truck	Other motor vehicle
2016-Dec-09, Fri,08:05	Clear	Rear end	P.D. only	Ice	East	Going ahead	Automobile, station wagon	Other motor vehicle
					East	Going ahead	Automobile, station wagon	Other motor vehicle
					East	Going ahead	Automobile, station wagon	Other motor vehicle
					East	Stopped	Passenger van	Other motor vehicle
2016-Dec-19, Mon,08:45	Clear	Rear end	P.D. only	Slush	East	Going ahead	Automobile, station wagon	Other motor vehicle
					East	Stopped	Automobile, station wagon	Other motor vehicle
2016-Dec-23, Fri,02:43	Clear	SMV other	P.D. only	Wet	West	Merging	Automobile, station wagon	Ran off road
2017-Jan-26, Thu,17:34	Clear	Angle	P.D. only	Dry	North	Going ahead	Automobile, station wagon	Other motor vehicle
					East	Going ahead	Passenger van	Other motor vehicle
					East	Going ahead	Truck-other	Other motor vehicle



2017-Mar-09, Thu,17:46	Clear	Rear end	P.D. only	Ice	North	Turning right	Automobile, station wagon	Other motor vehicle	
					North	Turning right	Pick-up truck	Other motor vehicle	
2016-Dec-09, Fri,09:20	Clear	Rear end	P.D. only	Ice	East	Slowing or stopping	Automobile, station wagon	Other motor vehicle	
					East	Stopped	Automobile, station wagon	Other motor vehicle	
2017-Apr-13, Thu,15:38	Clear	Rear end	P.D. only	Dry	South	Turning right	Automobile, station wagon	Other motor vehicle	
					South	Turning right	Passenger van	Other motor vehicle	
2017-Jun-07, Wed,23:02	Clear	SMV other	Non-fatal injury	Dry	West	Slowing or stopping	Automobile, station wagon	Pedestrian	1
2017-Jun-09, Fri,10:33	Clear	Turning movement	P.D. only	Dry	East	Turning left	Automobile, station wagon	Other motor vehicle	
					East	Going ahead	Passenger van	Other motor vehicle	
2017-Oct-11, Wed,13:00	Clear	Rear end	P.D. only	Dry	East	Turning left	Pick-up truck	Other motor vehicle	
					East	Turning left	Automobile, station wagon	Other motor vehicle	
2017-Nov-28, Tue,14:25	Clear	Rear end	P.D. only	Dry	East	Slowing or stopping	Unknown	Other motor vehicle	
					East	Turning right	Automobile, station wagon	Other motor vehicle	
2017-Sep-24, Sun,21:50	Clear	Angle	P.D. only	Dry	North	Going ahead	Automobile, station wagon	Other motor vehicle	

					East	Going ahead	Automobile, station wagon	Other motor vehicle
2017-Sep-10, Sun,14:31	Clear	Sideswipe	P.D. only	Dry	West	Changing lanes	Unknown	Other motor vehicle
					West	Going ahead	Automobile, station wagon	Other motor vehicle
2017-Nov-27, Mon,15:19	Clear	Rear end	P.D. only	Dry	West	Slowing or stopping	Automobile, station wagon	Other motor vehicle
					West	Stopped	Pick-up truck	Other motor vehicle
2017-Nov-28, Tue,13:30	Clear	Rear end	P.D. only	Loose snow	West	Going ahead	Automobile, station wagon	Other motor vehicle
					West	Stopped	Automobile, station wagon	Other motor vehicle
2017-Dec-07, Thu,11:20	Clear	Rear end	P.D. only	Dry	East	Going ahead	Automobile, station wagon	Other motor vehicle
					East	Stopped	Automobile, station wagon	Other motor vehicle
2018-Jan-24, Wed,10:51	Clear	Rear end	Non-fatal injury	Dry	East	Slowing or stopping	Truck - closed	Other motor vehicle
					East	Stopped	Automobile, station wagon	Other motor vehicle
2018-Jan-29, Mon,13:52	Clear	Turning movement	Non-fatal injury	Dry	East	Turning right	Automobile, station wagon	Other motor vehicle
					East	Going ahead	Pick-up truck	Other motor vehicle
2018-Jan-15, Mon,13:52	Clear	Rear end	P.D. only	Wet	East	Going ahead	Pick-up truck	Other motor vehicle

					East	Stopped	Automobile, station wagon	Other motor vehicle
					East	Stopped	Automobile, station wagon	Other motor vehicle
2017-Dec-22, Fri,13:45	Snow	Turning movement	P.D. only	Loose snow	East	Turning left	Automobile, station wagon	Other motor vehicle
					West	Going ahead	Automobile, station wagon	Other motor vehicle
2018-Mar-23, Fri,12:00	Clear	Sideswipe	P.D. only	Dry	East	Changing lanes	Delivery van	Other motor vehicle
					East	Going ahead	Delivery van	Other motor vehicle
2018-Jun-16, Sat,17:24	Clear	Rear end	P.D. only	Dry	North	Going ahead	Automobile, station wagon	Other motor vehicle
					North	Stopped	Automobile, station wagon	Other motor vehicle
2018-Aug-29, Wed,17:36	Clear	Other	P.D. only	Dry	East	Reversing	Unknown	Other motor vehicle
					West	Stopped	Automobile, station wagon	Other motor vehicle
2018-Sep-06, Thu,17:30	Clear	Rear end	P.D. only	Dry	West	Going ahead	Automobile, station wagon	Other motor vehicle
					West	Stopped	Automobile, station wagon	Other motor vehicle
2018-Jul-20, Fri,19:43	Clear	Angle	P.D. only	Dry	North	Going ahead	Automobile, station wagon	Other motor vehicle
					East	Going ahead	Automobile, station wagon	Other motor vehicle

2018-Aug-02, Thu,10:41	Clear	Sideswipe	P.D. only	Dry	West	Changing lanes	Automobile, station wagon	Other motor vehicle
					West	Going ahead	Automobile, station wagon	Other motor vehicle
2018-Oct-27, Sat,17:50	Clear	Angle	P.D. only	Dry	North	Going ahead	Automobile, station wagon	Other motor vehicle
					East	Going ahead	Automobile, station wagon	Other motor vehicle
					East	Going ahead	Automobile, station wagon	Other motor vehicle
2018-Dec-14, Fri,14:00	Freezing Rain	Rear end	P.D. only	Ice	North	Slowing or stopping	Automobile, station wagon	Skidding/sliding
					North	Stopped	Automobile, station wagon	Other motor vehicle
2018-Nov-10, Sat,18:45	Clear	Other	P.D. only	Dry	West	Reversing	Automobile, station wagon	Other motor vehicle
					East	Stopped	Automobile, station wagon	Other motor vehicle
2018-Dec-24, Mon,21:58	Clear	Rear end	P.D. only	Wet	West	Going ahead	Automobile, station wagon	Other motor vehicle
					West	Stopped	Automobile, station wagon	Other motor vehicle
					West	Stopped	Automobile, station wagon	Other motor vehicle

**Location:** POULIN AVE @ RICHMOND RD

**Traffic Control:** Traffic signal

**Total Collisions:** 23

Date/Day/Time	Environment	Impact Type	Classification	Surface Cond'n	Veh. Dir	Vehicle Manoeuver	Vehicle type	First Event	No. Ped
2014-Aug-02, Sat,13:00	Clear	Turning movement	P.D. only	Dry	North	Turning left	Automobile, station wagon	Other motor vehicle	

					North	Turning left	Automobile, station wagon	Other motor vehicle	
2014-Dec-02, Tue,17:10	Clear	Rear end	P.D. only	Wet	North	Slowing or stopping	Automobile, station wagon	Other motor vehicle	
					North	Stopped	Pick-up truck	Other motor vehicle	
2015-Feb-04, Wed,09:20	Snow	Rear end	P.D. only	Loose snow	West	Slowing or stopping	Automobile, station wagon	Other motor vehicle	
					West	Turning left	Automobile, station wagon	Other motor vehicle	
2015-Feb-04, Wed,09:00	Snow	Angle	P.D. only	Slush	East	Turning left	Automobile, station wagon	Other motor vehicle	
					South	Stopped	Automobile, station wagon	Other motor vehicle	
2015-Mar-26, Thu,10:37	Clear	Rear end	Non-fatal injury	Wet	East	Going ahead	Truck - dump	Other motor vehicle	
					East	Stopped	Pick-up truck	Other motor vehicle	
					East	Unknown	Unknown	Other motor vehicle	
2015-Nov-20, Fri,10:07	Clear	Angle	P.D. only	Dry	North	Going ahead	Pick-up truck	Other motor vehicle	
					West	Going ahead	Automobile, station wagon	Other motor vehicle	
2015-Dec-15, Tue,18:49	Clear	SMV other	Non-fatal injury	Dry	South	Turning left	Pick-up truck	Pedestrian	1
2015-Dec-03, Thu,07:44	Clear	Angle	P.D. only	Dry	North	Turning right	Pick-up truck	Other motor vehicle	

					East	Going ahead	Automobile, station wagon	Other motor vehicle
2016-Jan-27, Wed,14:56	Clear	Sideswipe	P.D. only	Wet	East	Changing lanes	Pick-up truck	Other motor vehicle
					East	Going ahead	Automobile, station wagon	Other motor vehicle
2016-Sep-09, Fri,13:24	Clear	Angle	Non-fatal injury	Dry	East	Going ahead	Bicycle	Other motor vehicle
					South	Going ahead	Pick-up truck	Cyclist
2016-Jul-01, Fri,00:12	Clear	Angle	P.D. only	Dry	West	Going ahead	Automobile, station wagon	Other motor vehicle
					South	Turning left	Automobile, station wagon	Other motor vehicle
2017-Jan-01, Sun,12:08	Snow	Rear end	Non-fatal injury	Wet	East	Going ahead	Municipal transit bus	Other motor vehicle
					East	Turning right	Pick-up truck	Other motor vehicle
2017-Jan-10, Tue,21:23	Snow	Turning movement	P.D. only	Loose snow	West	Turning right	Unknown	Other motor vehicle
					West	Stopped	Automobile, station wagon	Other motor vehicle
2016-Dec-01, Thu,16:47	Clear	Turning movement	P.D. only	Wet	South	Going ahead	Automobile, station wagon	Other motor vehicle
					North	Turning left	Automobile, station wagon	Other motor vehicle
2017-Apr-04, Tue,12:34	Rain	Turning movement	P.D. only	Wet	East	Going ahead	Automobile, station wagon	Other motor vehicle

					West	Turning left	Automobile, station wagon	Other motor vehicle
2017-Jun-27, Tue,13:50	Clear	Turning movement	P.D. only	Dry	East	Turning left	Automobile, station wagon	Other motor vehicle
					West	Changing lanes	Automobile, station wagon	Other motor vehicle
2017-Jun-20, Tue,08:24	Clear	Other	Non-fatal injury	Dry	East	Going ahead	Bicycle	Other motor vehicle
					West	Turning right	Truck - dump	Cyclist
2017-Dec-07, Thu,19:34	Clear	SMV other	Non-fatal injury	Dry	East	Going ahead	Automobile, station wagon	Skidding/sliding
2017-Sep-27, Wed,11:57	Clear	SMV other	P.D. only	Dry	West	Turning right	Automobile, station wagon	Pole (sign, parking meter)
2018-Feb-27, Tue,14:39	Clear	Turning movement	P.D. only	Dry	East	Turning left	Automobile, station wagon	Other motor vehicle
					West	Going ahead	Passenger van	Other motor vehicle
2018-Sep-04, Tue,10:53	Clear	Rear end	P.D. only	Dry	North	Slowing or stopping	Automobile, station wagon	Other motor vehicle
					North	Stopped	Automobile, station wagon	Other motor vehicle
2018-Aug-25, Sat,20:00	Clear	Turning movement	P.D. only	Dry	East	Turning left	Automobile, station wagon	Other motor vehicle
					West	Going ahead	Automobile, station wagon	Other motor vehicle
2018-Oct-27, Sat,13:10	Clear	Sideswipe	P.D. only	Dry	South	Merging	Automobile, station wagon	Other motor vehicle

South

Going ahead

Automobile,  
station wagon

Other motor  
vehicle



















---



## Appendix D – Existing Traffic Level of Service Outputs

HCM Signalized Intersection Capacity Analysis  
1: Croydon Ave & Richmond Rd

Existing (2019)  
AM Peak Hour

												
Movement	EBL	EBT	EBR	WBL	WBT	WBR	NBL	NBT	NBR	SBL	SBT	SBR
Lane Configurations												
Traffic Volume (vph)	20	512	57	15	343	15	34	26	73	25	65	34
Future Volume (vph)	20	512	57	15	343	15	34	26	73	25	65	34
Ideal Flow (vphpl)	1800	1800	1800	1800	1800	1800	1800	1800	1800	1800	1800	1800
Lane Width	3.4	3.4	3.7	3.0	3.4	3.7	3.5	3.5	3.7	3.7	4.8	3.7
Total Lost time (s)	6.4	6.4		6.4	6.4		6.1	6.1			6.1	
Lane Util. Factor	1.00	1.00		1.00	1.00		1.00	1.00			1.00	
Frbp, ped/bikes	1.00	1.00		1.00	1.00		1.00	0.94			0.98	
Flpb, ped/bikes	0.98	1.00		0.99	1.00		0.97	1.00			0.99	
Frft	1.00	0.99		1.00	0.99		1.00	0.89			0.96	
Flt Protected	0.95	1.00		0.95	1.00		0.95	1.00			0.99	
Satd. Flow (prot)	1559	1576		1581	1584		1388	1390			1848	
Flt Permitted	0.53	1.00		0.38	1.00		0.68	1.00			0.90	
Satd. Flow (perm)	865	1576		630	1584		999	1390			1680	
Peak-hour factor, PHF	0.90	0.90	0.90	0.90	0.90	0.90	0.90	0.90	0.90	0.90	0.90	0.90
Adj. Flow (vph)	22	569	63	17	381	17	38	29	81	28	72	38
RTOR Reduction (vph)	0	3	0	0	1	0	0	70	0	0	26	0
Lane Group Flow (vph)	22	629	0	17	397	0	38	40	0	0	112	0
Confl. Peds. (#/hr)	21		15	15		21	29		41	41		29
Heavy Vehicles (%)	5%	4%	15%	0%	6%	0%	18%	20%	3%	4%	0%	6%
Bus Blockages (#/hr)	0	10	0	0	10	0	0	0	0	0	0	0
Turn Type	Perm	NA		Perm	NA		Perm	NA		Perm	NA	
Protected Phases		2			6			8				4
Permitted Phases	2			6			8			4		
Actuated Green, G (s)	48.4	48.4		48.4	48.4		9.1	9.1			9.1	
Effective Green, g (s)	48.4	48.4		48.4	48.4		9.1	9.1			9.1	
Actuated g/C Ratio	0.69	0.69		0.69	0.69		0.13	0.13			0.13	
Clearance Time (s)	6.4	6.4		6.4	6.4		6.1	6.1			6.1	
Vehicle Extension (s)	3.0	3.0		3.0	3.0		3.0	3.0			3.0	
Lane Grp Cap (vph)	598	1089		435	1095		129	180			218	
v/s Ratio Prot		c0.40			0.25			0.03				
v/s Ratio Perm	0.03			0.03			0.04				c0.07	
v/c Ratio	0.04	0.58		0.04	0.36		0.29	0.22			0.51	
Uniform Delay, d1	3.4	5.5		3.4	4.4		27.5	27.3			28.4	
Progression Factor	1.00	1.00		1.00	1.00		1.00	1.00			1.00	
Incremental Delay, d2	0.1	2.2		0.2	0.9		1.3	0.6			2.0	
Delay (s)	3.5	7.8		3.6	5.4		28.8	27.9			30.4	
Level of Service	A	A		A	A		C	C			C	
Approach Delay (s)		7.6			5.3			28.1			30.4	
Approach LOS		A			A			C			C	
<b>Intersection Summary</b>												
HCM 2000 Control Delay			11.5				HCM 2000 Level of Service				B	
HCM 2000 Volume to Capacity ratio			0.57									
Actuated Cycle Length (s)			70.0				Sum of lost time (s)			12.5		
Intersection Capacity Utilization			61.1%				ICU Level of Service			B		
Analysis Period (min)			15									

c Critical Lane Group

HCM Signalized Intersection Capacity Analysis  
2: Alpine Ave/1460 Richmond & Carling Ave

Existing (2019)  
AM Peak Hour



Movement	EBL	EBT	EBR	WBL	WBT	WBR	NBL	NBT	NBR	SBL	SBT	SBR
Lane Configurations	↗	↑↑↑		↗	↑↑↑			↕			↕	
Traffic Volume (vph)	29	2483	5	30	857	68	22	7	87	41	9	52
Future Volume (vph)	29	2483	5	30	857	68	22	7	87	41	9	52
Ideal Flow (vphpl)	1800	1800	1800	1800	1800	1800	1800	1800	1800	1800	1800	1800
Lane Width	3.0	3.6	3.7	3.0	3.7	3.7	3.7	4.8	3.7	3.7	3.6	3.7
Total Lost time (s)	5.9	5.9		5.9	5.9			6.7			6.7	
Lane Util. Factor	1.00	0.91		1.00	0.91			1.00			1.00	
Frpb, ped/bikes	1.00	1.00		1.00	0.99			0.96			0.99	
Flpb, ped/bikes	0.98	1.00		1.00	1.00			1.00			0.99	
Fr t	1.00	1.00		1.00	0.99			0.90			0.93	
Fl t Protected	0.95	1.00		0.95	1.00			0.99			0.98	
Satd. Flow (prot)	1504	4764		1596	4642			1674			1569	
Fl t Permitted	0.27	1.00		0.04	1.00			0.88			0.68	
Satd. Flow (perm)	422	4764		67	4642			1485			1086	
Peak-hour factor, PHF	0.90	0.90	0.90	0.90	0.90	0.90	0.90	0.90	0.90	0.90	0.90	0.90
Adj. Flow (vph)	32	2759	6	33	952	76	24	8	97	46	10	58
RTOR Reduction (vph)	0	0	0	0	4	0	0	67	0	0	36	0
Lane Group Flow (vph)	32	2765	0	33	1024	0	0	62	0	0	78	0
Confl. Peds. (#/hr)	36		27	27		36	11		27	27		11
Heavy Vehicles (%)	4%	2%	0%	0%	4%	3%	10%	0%	3%	3%	0%	2%
Bus Blockages (#/hr)	0	8	0	0	8	0	0	0	0	0	0	0
Turn Type	Perm	NA		pm+pt	NA		Perm	NA		Perm	NA	
Protected Phases		2		1	6			8			4	
Permitted Phases	2			6			8			4		
Actuated Green, G (s)	93.9	93.9		103.7	103.7			13.7			13.7	
Effective Green, g (s)	93.9	93.9		103.7	103.7			13.7			13.7	
Actuated g/C Ratio	0.72	0.72		0.80	0.80			0.11			0.11	
Clearance Time (s)	5.9	5.9		5.9	5.9			6.7			6.7	
Vehicle Extension (s)	3.0	3.0		3.0	3.0			3.0			3.0	
Lane Grp Cap (vph)	304	3441		99	3702			156			114	
v/s Ratio Prot		c0.58		0.01	c0.22							
v/s Ratio Perm	0.08			0.25				0.04			c0.07	
v/c Ratio	0.11	0.80		0.33	0.28			0.40			0.69	
Uniform Delay, d1	5.4	11.9		14.0	3.4			54.3			56.1	
Progression Factor	1.00	1.00		3.71	0.83			1.00			1.00	
Incremental Delay, d2	0.7	2.1		1.9	0.2			1.7			15.8	
Delay (s)	6.1	14.0		53.8	3.0			56.0			71.8	
Level of Service	A	B		D	A			E			E	
Approach Delay (s)		13.9			4.6			56.0			71.8	
Approach LOS		B			A			E			E	
<b>Intersection Summary</b>												
HCM 2000 Control Delay			14.5									B
HCM 2000 Volume to Capacity ratio			0.78									
Actuated Cycle Length (s)			130.0							18.5		
Intersection Capacity Utilization			79.2%									D
Analysis Period (min)			15									

c Critical Lane Group

HCM Signalized Intersection Capacity Analysis  
3: Carling Ave & Croydon Ave

Existing (2019)  
AM Peak Hour



Movement	EBL	EBT	WBT	WBR	SBL	SBR
Lane Configurations	↙	↑↑↑	↑↑↑		↘↘	
Traffic Volume (vph)	93	2035	842	88	156	25
Future Volume (vph)	93	2035	842	88	156	25
Ideal Flow (vphpl)	1800	1800	1800	1800	1800	1800
Lane Width	2.8	3.6	3.7	3.7	3.7	3.3
Total Lost time (s)	5.9	5.9	5.9		6.3	
Lane Util. Factor	1.00	0.91	0.91		0.97	
Frpb, ped/bikes	1.00	1.00	0.99		1.00	
Flpb, ped/bikes	1.00	1.00	1.00		1.00	
Frt	1.00	1.00	0.99		0.98	
Flt Protected	0.95	1.00	1.00		0.96	
Satd. Flow (prot)	1525	4696	4590		3111	
Flt Permitted	0.24	1.00	1.00		0.96	
Satd. Flow (perm)	380	4696	4590		3111	
Peak-hour factor, PHF	0.90	0.90	0.90	0.90	0.90	0.90
Adj. Flow (vph)	103	2261	936	98	173	28
RTOR Reduction (vph)	0	0	7	0	12	0
Lane Group Flow (vph)	103	2261	1027	0	189	0
Confl. Peds. (#/hr)	16			16	2	19
Heavy Vehicles (%)	2%	2%	3%	7%	7%	0%
Bus Blockages (#/hr)	0	19	19	0	0	0
Turn Type	pm+pt	NA	NA		Prot	
Protected Phases	5	2	6		7	
Permitted Phases	2					
Actuated Green, G (s)	104.4	104.4	91.1		13.4	
Effective Green, g (s)	104.4	104.4	91.1		13.4	
Actuated g/C Ratio	0.80	0.80	0.70		0.10	
Clearance Time (s)	5.9	5.9	5.9		6.3	
Vehicle Extension (s)	3.0	3.0	3.0		3.0	
Lane Grp Cap (vph)	370	3771	3216		320	
v/s Ratio Prot	0.02	c0.48	0.22		c0.06	
v/s Ratio Perm	0.21					
v/c Ratio	0.28	0.60	0.32		0.59	
Uniform Delay, d1	3.2	4.9	7.5		55.7	
Progression Factor	0.59	0.35	1.00		1.00	
Incremental Delay, d2	0.3	0.4	0.3		2.9	
Delay (s)	2.2	2.2	7.8		58.6	
Level of Service	A	A	A		E	
Approach Delay (s)		2.2	7.8		58.6	
Approach LOS		A	A		E	

Intersection Summary

HCM 2000 Control Delay	6.9	HCM 2000 Level of Service	A
HCM 2000 Volume to Capacity ratio	0.63		
Actuated Cycle Length (s)	130.0	Sum of lost time (s)	18.1
Intersection Capacity Utilization	68.2%	ICU Level of Service	C
Analysis Period (min)	15		

c Critical Lane Group

HCM Unsignalized Intersection Capacity Analysis  
4: Carling Ave & Forest St

Existing (2019)  
AM Peak Hour



Movement	EBL	EBT	WBT	WBR	SBL	SBR	
Lane Configurations		↑↑↑	↑↑↑			↑	
Traffic Volume (veh/h)	0	2611	907	22	0	48	
Future Volume (Veh/h)	0	2611	907	22	0	48	
Sign Control		Free	Free		Stop		
Grade		0%	0%		0%		
Peak Hour Factor	0.90	0.90	0.90	0.90	0.90	0.90	
Hourly flow rate (vph)	0	2901	1008	24	0	53	
<b>Pedestrians</b>							
Lane Width (m)							
Walking Speed (m/s)							
Percent Blockage							
Right turn flare (veh)							
Median type		None	None				
Median storage (veh)							
Upstream signal (m)		55	141				
pX, platoon unblocked	0.93				0.64	0.93	
vC, conflicting volume	1032				1987	348	
vC1, stage 1 conf vol							
vC2, stage 2 conf vol							
vCu, unblocked vol	786				0	53	
tC, single (s)	4.1				6.8	6.9	
tC, 2 stage (s)							
tF (s)	2.2				3.5	3.3	
p0 queue free %	100				100	94	
cM capacity (veh/h)	786				655	943	
<b>Direction, Lane #</b>	<b>EB 1</b>	<b>EB 2</b>	<b>EB 3</b>	<b>WB 1</b>	<b>WB 2</b>	<b>WB 3</b>	<b>SB 1</b>
Volume Total	967	967	967	403	403	226	53
Volume Left	0	0	0	0	0	0	0
Volume Right	0	0	0	0	0	24	53
cSH	1700	1700	1700	1700	1700	1700	943
Volume to Capacity	0.57	0.57	0.57	0.24	0.24	0.13	0.06
Queue Length 95th (m)	0.0	0.0	0.0	0.0	0.0	0.0	1.4
Control Delay (s)	0.0	0.0	0.0	0.0	0.0	0.0	9.0
Lane LOS							A
Approach Delay (s)	0.0			0.0			9.0
Approach LOS							A
<b>Intersection Summary</b>							
Average Delay			0.1				
Intersection Capacity Utilization			56.6%		ICU Level of Service		B
Analysis Period (min)			15				

HCM Unsignalized Intersection Capacity Analysis  
5: Croydon Ave & Bond St

Existing (2019)  
AM Peak Hour



Movement	EBL	EBR	NBL	NBT	SBT	SBR
Lane Configurations						
Traffic Volume (veh/h)	1	9	9	172	172	9
Future Volume (Veh/h)	1	9	9	172	172	9
Sign Control	Stop			Free	Free	
Grade	0%			0%	0%	
Peak Hour Factor	0.90	0.90	0.90	0.90	0.90	0.90
Hourly flow rate (vph)	1	10	10	191	191	10
<b>Pedestrians</b>						
Lane Width (m)						
Walking Speed (m/s)						
Percent Blockage						
Right turn flare (veh)						
Median type				None	None	
Median storage (veh)						
Upstream signal (m)				78	181	
pX, platoon unblocked						
vC, conflicting volume	407	196	201			
vC1, stage 1 conf vol						
vC2, stage 2 conf vol						
vCu, unblocked vol	407	196	201			
tC, single (s)	6.4	6.2	4.1			
tC, 2 stage (s)						
tF (s)	3.5	3.3	2.2			
p0 queue free %	100	99	99			
cM capacity (veh/h)	600	850	1383			
<b>Direction, Lane #</b>	<b>EB 1</b>	<b>NB 1</b>	<b>SB 1</b>			
Volume Total	11	201	201			
Volume Left	1	10	0			
Volume Right	10	0	10			
cSH	819	1383	1700			
Volume to Capacity	0.01	0.01	0.12			
Queue Length 95th (m)	0.3	0.2	0.0			
Control Delay (s)	9.5	0.4	0.0			
Lane LOS	A	A				
Approach Delay (s)	9.5	0.4	0.0			
Approach LOS	A					
<b>Intersection Summary</b>						
Average Delay			0.5			
Intersection Capacity Utilization			27.3%	ICU Level of Service	A	
Analysis Period (min)			15			

HCM Unsignalized Intersection Capacity Analysis  
6: Forest St & Bond St

Existing (2019)  
AM Peak Hour



Movement	WBL	WBR	NBT	NBR	SBL	SBT
Lane Configurations						
Traffic Volume (veh/h)	1	6	22	1	12	47
Future Volume (Veh/h)	1	6	22	1	12	47
Sign Control	Stop		Free		Free	
Grade	0%		0%		0%	
Peak Hour Factor	0.90	0.90	0.90	0.90	0.90	0.90
Hourly flow rate (vph)	1	7	24	1	13	52
Pedestrians						
Lane Width (m)						
Walking Speed (m/s)						
Percent Blockage						
Right turn flare (veh)						
Median type			None	None		
Median storage (veh)						
Upstream signal (m)						
pX, platoon unblocked						
vC, conflicting volume	102	24			25	
vC1, stage 1 conf vol						
vC2, stage 2 conf vol						
vCu, unblocked vol	102	24			25	
tC, single (s)	6.4	6.2			4.1	
tC, 2 stage (s)						
tF (s)	3.5	3.3			2.2	
p0 queue free %	100	99			99	
cM capacity (veh/h)	893	1058			1603	
<b>Direction, Lane #</b>						
	WB 1	NB 1	SB 1			
Volume Total	8	25	65			
Volume Left	1	0	13			
Volume Right	7	1	0			
cSH	1034	1700	1603			
Volume to Capacity	0.01	0.01	0.01			
Queue Length 95th (m)	0.2	0.0	0.2			
Control Delay (s)	8.5	0.0	1.5			
Lane LOS	A		A			
Approach Delay (s)	8.5	0.0	1.5			
Approach LOS	A					
<b>Intersection Summary</b>						
Average Delay			1.7			
Intersection Capacity Utilization			20.0%	ICU Level of Service		A
Analysis Period (min)			15			

HCM Unsignalized Intersection Capacity Analysis  
7: Forest St & Richmond Rd

Existing (2019)  
AM Peak Hour

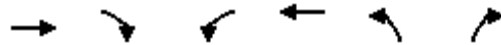

























Movement	EBT	EBR	WBL	WBT	NBL	NBR
Lane Configurations	→			←	↘	↙
Traffic Volume (veh/h)	560	10	21	390	10	29
Future Volume (Veh/h)	560	10	21	390	10	29
Sign Control	Free			Free	Stop	
Grade	0%			0%	0%	
Peak Hour Factor	0.90	0.90	0.90	0.90	0.90	0.90
Hourly flow rate (vph)	622	11	23	433	11	32
<b>Pedestrians</b>						
Lane Width (m)						
Walking Speed (m/s)						
Percent Blockage						
Right turn flare (veh)						
Median type	None			None		
Median storage (veh)						
Upstream signal (m)	279			154		
pX, platoon unblocked				0.91	0.94	0.91
vC, conflicting volume				633	1106	628
vC1, stage 1 conf vol						
vC2, stage 2 conf vol						
vCu, unblocked vol				542	918	536
tC, single (s)				4.1	6.4	6.2
tC, 2 stage (s)						
tF (s)				2.2	3.5	3.3
p0 queue free %				98	96	94
cM capacity (veh/h)				938	279	496
<b>Direction, Lane #</b>	<b>EB 1</b>	<b>WB 1</b>	<b>NB 1</b>			
Volume Total	633	456	43			
Volume Left	0	23	11			
Volume Right	11	0	32			
cSH	1700	938	414			
Volume to Capacity	0.37	0.02	0.10			
Queue Length 95th (m)	0.0	0.6	2.6			
Control Delay (s)	0.0	0.7	14.7			
Lane LOS	A		B			
Approach Delay (s)	0.0	0.7	14.7			
Approach LOS	B					
<b>Intersection Summary</b>						
Average Delay	0.9					
Intersection Capacity Utilization	49.8%			ICU Level of Service	A	
Analysis Period (min)	15					



HCM Signalized Intersection Capacity Analysis  
9: Richmond Rd & Carling Ave























Existing (2019)  
AM Peak Hour

												
Movement	EBL	EBT	EBR	WBL	WBT	WBR	NBL	NBT	NBR	SBL	SBT	SBR
Lane Configurations		 			  			 			 	
Traffic Volume (vph)	147	1394	0	4	906	0	0	484	1123	0	280	178
Future Volume (vph)	147	1394	0	4	906	0	0	484	1123	0	280	178
Ideal Flow (vphpl)	1800	1800	1800	1800	1800	1800	1800	1800	1800	1800	1800	1800
Total Lost time (s)	6.0	5.8		6.0	5.8			7.0	4.0		7.0	4.0
Lane Util. Factor	1.00	0.95		1.00	0.91			0.95	1.00		0.95	1.00
Frpb, ped/bikes	1.00	1.00		1.00	1.00			1.00	0.99		1.00	0.98
Flpb, ped/bikes	1.00	1.00		1.00	1.00			1.00	1.00		1.00	1.00
Frt	1.00	1.00		1.00	1.00			1.00	0.85		1.00	0.85
Flt Protected	0.95	1.00		0.95	1.00			1.00	1.00		1.00	1.00
Satd. Flow (prot)	1679	3369		864	4772			3325	1495		3325	1479
Flt Permitted	0.95	1.00		0.95	1.00			1.00	1.00		1.00	1.00
Satd. Flow (perm)	1679	3369		864	4772			3325	1495		3325	1479
Peak-hour factor, PHF	0.90	0.90	0.90	0.90	0.90	0.90	0.90	0.90	0.90	0.90	0.90	0.90
Adj. Flow (vph)	163	1549	0	4	1007	0	0	538	1248	0	311	198
RTOR Reduction (vph)	0	0	0	0	0	0	0	0	0	0	0	0
Lane Group Flow (vph)	163	1549	0	4	1007	0	0	538	1248	0	311	198
Confl. Peds. (#/hr)	8		7	7		8	6		4	4		6
Confl. Bikes (#/hr)	8		7	7		8	6		4	4		6
Heavy Vehicles (%)	3%	1%	0%	100%	3%	0%	0%	4%	2%	0%	4%	3%
Bus Blockages (#/hr)	0	8	0	0	8	0	0	0	0	0	0	0
Turn Type	Prot	NA		Prot	NA			NA	Free		NA	Free
Protected Phases	5	2		19	6			8			4	
Permitted Phases									Free			Free
Actuated Green, G (s)	17.6	63.2		3.0	54.6			39.0	130.0		39.0	130.0
Effective Green, g (s)	17.6	63.2		3.0	54.6			39.0	130.0		39.0	130.0
Actuated g/C Ratio	0.14	0.49		0.02	0.42			0.30	1.00		0.30	1.00
Clearance Time (s)	6.0	5.8			5.8			7.0			7.0	
Vehicle Extension (s)	3.0	3.0			3.0			3.0			3.0	
Lane Grp Cap (vph)	227	1637		19	2004			997	1495		997	1479
v/s Ratio Prot	0.10	c0.46		0.00	0.21			0.16			0.09	
v/s Ratio Perm									c0.83			0.13
v/c Ratio	0.72	0.95		0.21	0.50			0.54	0.83		0.31	0.13
Uniform Delay, d1	53.8	31.8		62.3	27.7			38.0	0.0		35.1	0.0
Progression Factor	1.00	1.00		1.00	1.00			1.00	1.00		0.92	1.00
Incremental Delay, d2	10.3	12.7		5.5	0.9			2.1	5.7		0.2	0.2
Delay (s)	64.2	44.5		67.8	28.6			40.1	5.7		32.6	0.2
Level of Service	E	D		E	C			D	A		C	A
Approach Delay (s)		46.4			28.8			16.0			20.0	
Approach LOS		D			C			B			B	
<b>Intersection Summary</b>												
HCM 2000 Control Delay			29.3									C
HCM 2000 Volume to Capacity ratio			1.06									
Actuated Cycle Length (s)			130.0								24.8	
Intersection Capacity Utilization			97.2%									F
Analysis Period (min)			15									

c Critical Lane Group

HCM Signalized Intersection Capacity Analysis  
10: Poulin St & Richmond Rd

Existing (2019)  
AM Peak Hour

												
Movement	EBL	EBT	EBR	WBL	WBT	WBR	NBL	NBT	NBR	SBL	SBT	SBR
Lane Configurations					 			 			 	 
Traffic Volume (vph)	120	509	2	0	375	27	2	18	3	68	0	81
Future Volume (vph)	120	509	2	0	375	27	2	18	3	68	0	81
Ideal Flow (vphpl)	1800	1800	1800	1800	1800	1800	1800	1800	1800	1800	1800	1800
Total Lost time (s)	6.3	6.3			6.3			6.2			6.2	6.2
Lane Util. Factor	1.00	1.00			0.95			1.00			1.00	1.00
Frbp, ped/bikes	1.00	1.00			1.00			0.99			1.00	0.96
Flpb, ped/bikes	0.99	1.00			1.00			1.00			0.99	1.00
Frt	1.00	1.00			0.99			0.98			1.00	0.85
Flt Protected	0.95	1.00			1.00			1.00			0.95	1.00
Satd. Flow (prot)	1623	1732			3286			1703			1452	1421
Flt Permitted	0.49	1.00			1.00			0.98			0.74	1.00
Satd. Flow (perm)	843	1732			3286			1673			1132	1421
Peak-hour factor, PHF	0.90	0.90	0.90	0.90	0.90	0.90	0.90	0.90	0.90	0.90	0.90	0.90
Adj. Flow (vph)	133	566	2	0	417	30	2	20	3	76	0	90
RTOR Reduction (vph)	0	0	0	0	3	0	0	3	0	0	0	80
Lane Group Flow (vph)	133	568	0	0	444	0	0	22	0	0	76	10
Confl. Peds. (#/hr)	10		5	5		10	7		4	4		7
Confl. Bikes (#/hr)	10		5	5		10	7		4	4		7
Heavy Vehicles (%)	5%	5%	0%	0%	3%	15%	0%	0%	34%	18%	0%	5%
Turn Type	Perm	NA			NA		Perm	NA		Perm	NA	Perm
Protected Phases		2			6			8			4	
Permitted Phases	2						8			4		4
Actuated Green, G (s)	102.9	102.9			102.9			14.6			14.6	14.6
Effective Green, g (s)	102.9	102.9			102.9			14.6			14.6	14.6
Actuated g/C Ratio	0.79	0.79			0.79			0.11			0.11	0.11
Clearance Time (s)	6.3	6.3			6.3			6.2			6.2	6.2
Vehicle Extension (s)	3.0	3.0			3.0			3.0			3.0	3.0
Lane Grp Cap (vph)	667	1370			2600			187			127	159
v/s Ratio Prot		c0.33			0.14							
v/s Ratio Perm	0.16							0.01			c0.07	0.01
v/c Ratio	0.20	0.41			0.17			0.12			0.60	0.06
Uniform Delay, d1	3.4	4.2			3.3			51.9			54.9	51.6
Progression Factor	0.01	0.81			1.00			1.00			1.00	1.00
Incremental Delay, d2	0.6	0.8			0.1			0.3			7.4	0.2
Delay (s)	0.6	4.2			3.4			52.2			62.3	51.8
Level of Service	A	A			A			D			E	D
Approach Delay (s)		3.5			3.4			52.2			56.6	
Approach LOS		A			A			D			E	
<b>Intersection Summary</b>												
HCM 2000 Control Delay			11.0		HCM 2000 Level of Service			B				
HCM 2000 Volume to Capacity ratio			0.44									
Actuated Cycle Length (s)			130.0		Sum of lost time (s)			12.5				
Intersection Capacity Utilization			57.1%		ICU Level of Service			B				
Analysis Period (min)			15									
c Critical Lane Group												

HCM Signalized Intersection Capacity Analysis  
1: Croydon Ave & Richmond Rd

Existing (2019)  
PM Peak Hour

Movement	EBL	EBT	EBR	WBL	WBT	WBR	NBL	NBT	NBR	SBL	SBT	SBR
Lane Configurations												
Traffic Volume (vph)	23	419	82	54	744	16	118	89	33	13	56	18
Future Volume (vph)	23	419	82	54	744	16	118	89	33	13	56	18
Ideal Flow (vphpl)	1800	1800	1800	1800	1800	1800	1800	1800	1800	1800	1800	1800
Lane Width	3.4	3.4	3.7	3.0	3.4	3.7	3.5	3.5	3.7	3.7	4.8	3.7
Total Lost time (s)	6.4	6.4		6.4	6.4		6.1	6.1			6.1	
Lane Util. Factor	1.00	1.00		1.00	1.00		1.00	1.00			1.00	
Frpb, ped/bikes	1.00	0.99		1.00	1.00		1.00	0.97			0.99	
Flpb, ped/bikes	0.99	1.00		0.98	1.00		0.96	1.00			0.99	
Fr <sub>t</sub>	1.00	0.98		1.00	1.00		1.00	0.96			0.97	
Fl <sub>t</sub> Protected	0.95	1.00		0.95	1.00		0.95	1.00			0.99	
Satd. Flow (prot)	1654	1582		1533	1649		1558	1635			1917	
Fl <sub>t</sub> Permitted	0.24	1.00		0.41	1.00		0.76	1.00			0.94	
Satd. Flow (perm)	422	1582		662	1649		1246	1635			1814	
Peak-hour factor, PHF	0.90	0.90	0.90	0.90	0.90	0.90	0.90	0.90	0.90	0.90	0.90	0.90
Adj. Flow (vph)	26	466	91	60	827	18	131	99	37	14	62	20
RTOR Reduction (vph)	0	6	0	0	1	0	0	18	0	0	13	0
Lane Group Flow (vph)	26	551	0	60	844	0	131	118	0	0	83	0
Confl. Peds. (#/hr)	30		24	24		30	29		59	59		29
Heavy Vehicles (%)	0%	2%	8%	2%	2%	0%	4%	0%	4%	0%	0%	0%
Bus Blockages (#/hr)	0	10	0	0	10	0	0	0	0	0	0	0
Turn Type	Perm	NA		Perm	NA		Perm	NA		Perm	NA	
Protected Phases		2			6			8			4	
Permitted Phases	2			6			8			4		
Actuated Green, G (s)	57.9	57.9		57.9	57.9		14.6	14.6			14.6	
Effective Green, g (s)	57.9	57.9		57.9	57.9		14.6	14.6			14.6	
Actuated g/C Ratio	0.68	0.68		0.68	0.68		0.17	0.17			0.17	
Clearance Time (s)	6.4	6.4		6.4	6.4		6.1	6.1			6.1	
Vehicle Extension (s)	3.0	3.0		3.0	3.0		3.0	3.0			3.0	
Lane Grp Cap (vph)	287	1077		450	1123		214	280			311	
v/s Ratio Prot		0.35			c0.51			0.07				
v/s Ratio Perm	0.06			0.09			c0.11				0.05	
v/c Ratio	0.09	0.51		0.13	0.75		0.61	0.42			0.27	
Uniform Delay, d1	4.6	6.6		4.8	8.9		32.6	31.4			30.6	
Progression Factor	1.00	1.00		1.00	1.00		1.00	1.00			1.00	
Incremental Delay, d2	0.6	1.7		0.6	4.7		5.1	1.0			0.5	
Delay (s)	5.2	8.4		5.4	13.5		37.7	32.4			31.0	
Level of Service	A	A		A	B		D	C			C	
Approach Delay (s)		8.2			13.0			35.0			31.0	
Approach LOS		A			B			D			C	
<b>Intersection Summary</b>												
HCM 2000 Control Delay			15.6				HCM 2000 Level of Service				B	
HCM 2000 Volume to Capacity ratio			0.72									
Actuated Cycle Length (s)			85.0				Sum of lost time (s)			12.5		
Intersection Capacity Utilization			77.6%				ICU Level of Service			D		
Analysis Period (min)			15									

c Critical Lane Group

HCM Signalized Intersection Capacity Analysis  
 2: Alpine Ave/1460 Richmond & Carling Ave

Existing (2019)  
 PM Peak Hour



Movement	EBL	EBT	EBR	WBL	WBT	WBR	NBL	NBT	NBR	SBL	SBT	SBR
Lane Configurations	↗	↑↑↑		↗	↑↑↑			↕			↕	
Traffic Volume (vph)	23	1062	8	46	1770	69	17	13	27	43	15	32
Future Volume (vph)	23	1062	8	46	1770	69	17	13	27	43	15	32
Ideal Flow (vphpl)	1800	1800	1800	1800	1800	1800	1800	1800	1800	1800	1800	1800
Lane Width	3.0	3.6	3.7	3.0	3.7	3.7	3.7	4.8	3.7	3.7	3.6	3.7
Total Lost time (s)	5.9	5.9		5.9	5.9			6.7			6.7	
Lane Util. Factor	1.00	0.91		1.00	0.91			1.00			1.00	
Frpb, ped/bikes	1.00	1.00		1.00	1.00			0.98			0.98	
Flpb, ped/bikes	1.00	1.00		1.00	1.00			0.99			0.99	
Fr <sub>t</sub>	1.00	1.00		1.00	0.99			0.94			0.95	
Fl <sub>t</sub> Protected	0.95	1.00		0.95	1.00			0.99			0.98	
Satd. Flow (prot)	1596	4760		1548	4821			1740			1609	
Fl <sub>t</sub> Permitted	0.07	1.00		0.21	1.00			0.85			0.85	
Satd. Flow (perm)	122	4760		337	4821			1509			1399	
Peak-hour factor, PHF	0.90	0.90	0.90	0.90	0.90	0.90	0.90	0.90	0.90	0.90	0.90	0.90
Adj. Flow (vph)	26	1180	9	51	1967	77	19	14	30	48	17	36
RTOR Reduction (vph)	0	0	0	0	2	0	0	27	0	0	19	0
Lane Group Flow (vph)	26	1189	0	51	2042	0	0	36	0	0	82	0
Confl. Peds. (#/hr)	40		13	13		40	32		14	14		32
Heavy Vehicles (%)	0%	2%	0%	3%	1%	0%	12%	0%	4%	3%	0%	0%
Bus Blockages (#/hr)	0	8	0	0	8	0	0	0	0	0	0	0
Turn Type	pm+pt	NA		pm+pt	NA		Perm	NA		Perm	NA	
Protected Phases	5	2		1	6			8			4	
Permitted Phases	2			6			8			4		
Actuated Green, G (s)	96.3	92.5		99.3	94.0			13.7			13.7	
Effective Green, g (s)	96.3	92.5		99.3	94.0			13.7			13.7	
Actuated g/C Ratio	0.74	0.71		0.76	0.72			0.11			0.11	
Clearance Time (s)	5.9	5.9		5.9	5.9			6.7			6.7	
Vehicle Extension (s)	3.0	3.0		3.0	3.0			3.0			3.0	
Lane Grp Cap (vph)	133	3386		306	3485			159			147	
v/s Ratio Prot	0.01	0.25		c0.01	c0.42							
v/s Ratio Perm	0.14			0.12				0.02			c0.06	
v/c Ratio	0.20	0.35		0.17	0.59			0.23			0.56	
Uniform Delay, d <sub>1</sub>	6.0	7.2		4.0	8.6			53.3			55.3	
Progression Factor	1.83	1.05		0.94	0.64			1.00			1.00	
Incremental Delay, d <sub>2</sub>	0.7	0.3		0.2	0.6			0.7			4.6	
Delay (s)	11.6	7.9		4.0	6.1			54.0			59.8	
Level of Service	B	A		A	A			D			E	
Approach Delay (s)		8.0			6.1			54.0			59.8	
Approach LOS		A			A			D			E	

Intersection Summary

HCM 2000 Control Delay	9.2	HCM 2000 Level of Service	A
HCM 2000 Volume to Capacity ratio	0.57		
Actuated Cycle Length (s)	130.0	Sum of lost time (s)	18.5
Intersection Capacity Utilization	73.9%	ICU Level of Service	D
Analysis Period (min)	15		

c Critical Lane Group

# HCM Signalized Intersection Capacity Analysis

## 3: Carling Ave & Croydon Ave

Existing (2019)  
PM Peak Hour

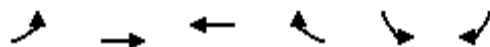

Movement	EBL	EBT	WBT	WBR	SBL	SBR
Lane Configurations	↵	↑↑↑	↑↑↑		↵↵	
Traffic Volume (vph)	64	1100	1936	128	147	81
Future Volume (vph)	64	1100	1936	128	147	81
Ideal Flow (vphpl)	1800	1800	1800	1800	1800	1800
Lane Width	2.8	3.6	3.7	3.7	3.7	3.3
Total Lost time (s)	5.9	5.9	5.9		6.3	
Lane Util. Factor	1.00	0.91	0.91		0.97	
Frpb, ped/bikes	1.00	1.00	0.99		0.99	
Flpb, ped/bikes	1.00	1.00	1.00		1.00	
Frt	1.00	1.00	0.99		0.95	
Flt Protected	0.95	1.00	1.00		0.97	
Satd. Flow (prot)	1527	4696	4701		3113	
Flt Permitted	0.05	1.00	1.00		0.97	
Satd. Flow (perm)	74	4696	4701		3113	
Peak-hour factor, PHF	0.90	0.90	0.90	0.90	0.90	0.90
Adj. Flow (vph)	71	1222	2151	142	163	90
RTOR Reduction (vph)	0	0	4	0	74	0
Lane Group Flow (vph)	71	1222	2289	0	179	0
Confl. Peds. (#/hr)	39			39	3	22
Heavy Vehicles (%)	2%	2%	1%	5%	4%	0%
Bus Blockages (#/hr)	0	19	19	0	0	0
Turn Type	pm+pt	NA	NA		Prot	
Protected Phases	5	2	6		7	
Permitted Phases	2					
Actuated Green, G (s)	104.7	104.7	92.4		13.1	
Effective Green, g (s)	104.7	104.7	92.4		13.1	
Actuated g/C Ratio	0.81	0.81	0.71		0.10	
Clearance Time (s)	5.9	5.9	5.9		6.3	
Vehicle Extension (s)	3.0	3.0	3.0		3.0	
Lane Grp Cap (vph)	131	3782	3341		313	
v/s Ratio Prot	c0.03	0.26	c0.49		c0.06	
v/s Ratio Perm	0.41					
v/c Ratio	0.54	0.32	0.69		0.57	
Uniform Delay, d1	14.2	3.3	10.6		55.8	
Progression Factor	1.95	0.41	1.00		1.00	
Incremental Delay, d2	4.3	0.2	1.2		2.5	
Delay (s)	32.0	1.6	11.8		58.3	
Level of Service	C	A	B		E	
Approach Delay (s)		3.2	11.8		58.3	
Approach LOS		A	B		E	

### Intersection Summary

HCM 2000 Control Delay	12.0	HCM 2000 Level of Service	B
HCM 2000 Volume to Capacity ratio	0.66		
Actuated Cycle Length (s)	130.0	Sum of lost time (s)	18.1
Intersection Capacity Utilization	79.4%	ICU Level of Service	D
Analysis Period (min)	15		

c Critical Lane Group

HCM Unsignalized Intersection Capacity Analysis  
 4: Carling Ave & Forest St

Existing (2019)  
 PM Peak Hour



Movement	EBL	EBT	WBT	WBR	SBL	SBR	
Lane Configurations		↑↑↑	↑↑↑			↑	
Traffic Volume (veh/h)	0	1132	1791	32	0	94	
Future Volume (Veh/h)	0	1132	1791	32	0	94	
Sign Control		Free	Free		Stop		
Grade		0%	0%		0%		
Peak Hour Factor	0.90	0.90	0.90	0.90	0.90	0.90	
Hourly flow rate (vph)	0	1258	1990	36	0	104	
<b>Pedestrians</b>							
Lane Width (m)							
Walking Speed (m/s)							
Percent Blockage							
Right turn flare (veh)							
Median type		None	None				
Median storage (veh)							
Upstream signal (m)		55	141				
pX, platoon unblocked	0.74				0.79	0.74	
vC, conflicting volume	2026				2427	681	
vC1, stage 1 conf vol							
vC2, stage 2 conf vol							
vCu, unblocked vol	1167				1081	0	
tC, single (s)	4.1				6.8	6.9	
tC, 2 stage (s)							
tF (s)	2.2				3.5	3.3	
p0 queue free %	100				100	87	
cM capacity (veh/h)	450				170	810	
Direction, Lane #	EB 1	EB 2	EB 3	WB 1	WB 2	WB 3	SB 1
Volume Total	419	419	419	796	796	434	104
Volume Left	0	0	0	0	0	0	0
Volume Right	0	0	0	0	0	36	104
cSH	1700	1700	1700	1700	1700	1700	810
Volume to Capacity	0.25	0.25	0.25	0.47	0.47	0.26	0.13
Queue Length 95th (m)	0.0	0.0	0.0	0.0	0.0	0.0	3.3
Control Delay (s)	0.0	0.0	0.0	0.0	0.0	0.0	10.1
Lane LOS							B
Approach Delay (s)	0.0			0.0			10.1
Approach LOS							B
<b>Intersection Summary</b>							
Average Delay			0.3				
Intersection Capacity Utilization			50.1%	ICU Level of Service		A	
Analysis Period (min)			15				

HCM Unsignalized Intersection Capacity Analysis  
5: Croydon Ave & Bond St

Existing (2019)  
PM Peak Hour



Movement	EBL	EBR	NBL	NBT	SBT	SBR
Lane Configurations						
Traffic Volume (veh/h)	1	11	10	182	217	11
Future Volume (Veh/h)	1	11	10	182	217	11
Sign Control	Stop			Free	Free	
Grade	0%			0%	0%	
Peak Hour Factor	0.90	0.90	0.90	0.90	0.90	0.90
Hourly flow rate (vph)	1	12	11	202	241	12
<b>Pedestrians</b>						
Lane Width (m)						
Walking Speed (m/s)						
Percent Blockage						
Right turn flare (veh)						
Median type				None	None	
Median storage veh						
Upstream signal (m)				78	181	
pX, platoon unblocked						
vC, conflicting volume	471	247	253			
vC1, stage 1 conf vol						
vC2, stage 2 conf vol						
vCu, unblocked vol	471	247	253			
tC, single (s)	6.4	6.2	4.1			
tC, 2 stage (s)						
tF (s)	3.5	3.3	2.2			
p0 queue free %	100	98	99			
cM capacity (veh/h)	550	797	1324			
<b>Direction, Lane #</b>	<b>EB 1</b>	<b>NB 1</b>	<b>SB 1</b>			
Volume Total	13	213	253			
Volume Left	1	11	0			
Volume Right	12	0	12			
cSH	770	1324	1700			
Volume to Capacity	0.02	0.01	0.15			
Queue Length 95th (m)	0.4	0.2	0.0			
Control Delay (s)	9.8	0.5	0.0			
Lane LOS	A	A				
Approach Delay (s)	9.8	0.5	0.0			
Approach LOS	A					
<b>Intersection Summary</b>						
Average Delay	0.5					
Intersection Capacity Utilization	28.7%			ICU Level of Service	A	
Analysis Period (min)	15					

HCM Unsignalized Intersection Capacity Analysis  
6: Forest St & Bond St

Existing (2019)  
PM Peak Hour



Movement	WBL	WBR	NBT	NBR	SBL	SBT
Lane Configurations						
Traffic Volume (veh/h)	1	8	32	1	24	93
Future Volume (Veh/h)	1	8	32	1	24	93
Sign Control	Stop		Free		Free	
Grade	0%		0%		0%	
Peak Hour Factor	0.90	0.90	0.90	0.90	0.90	0.90
Hourly flow rate (vph)	1	9	36	1	27	103
<b>Pedestrians</b>						
Lane Width (m)						
Walking Speed (m/s)						
Percent Blockage						
Right turn flare (veh)						
Median type	None			None		
Median storage (veh)						
Upstream signal (m)						
pX, platoon unblocked						
vC, conflicting volume	194	36			37	
vC1, stage 1 conf vol						
vC2, stage 2 conf vol						
vCu, unblocked vol	194	36			37	
tC, single (s)	6.4	6.2			4.1	
tC, 2 stage (s)						
tF (s)	3.5	3.3			2.2	
p0 queue free %	100	99			98	
cM capacity (veh/h)	786	1042			1587	
<b>Direction, Lane #</b>	<b>WB 1</b>	<b>NB 1</b>	<b>SB 1</b>			
Volume Total	10	37	130			
Volume Left	1	0	27			
Volume Right	9	1	0			
cSH	1009	1700	1587			
Volume to Capacity	0.01	0.02	0.02			
Queue Length 95th (m)	0.2	0.0	0.4			
Control Delay (s)	8.6	0.0	1.6			
Lane LOS	A		A			
Approach Delay (s)	8.6	0.0	1.6			
Approach LOS	A					
<b>Intersection Summary</b>						
Average Delay			1.7			
Intersection Capacity Utilization			23.2%	ICU Level of Service	A	
Analysis Period (min)			15			



HCM Unsignalized Intersection Capacity Analysis  
7: Forest St & Richmond Rd





















Existing (2019)  
PM Peak Hour



Movement	EBT	EBR	WBL	WBT	NBL	NBR
Lane Configurations	→			←	↘	↙
Traffic Volume (veh/h)	498	10	44	836	10	26
Future Volume (Veh/h)	498	10	44	836	10	26
Sign Control	Free			Free	Stop	
Grade	0%			0%	0%	
Peak Hour Factor	0.90	0.90	0.90	0.90	0.90	0.90
Hourly flow rate (vph)	553	11	49	929	11	29
<b>Pedestrians</b>						
Lane Width (m)						
Walking Speed (m/s)						
Percent Blockage						
Right turn flare (veh)						
Median type	None			None		
Median storage (veh)						
Upstream signal (m)	279			154		
pX, platoon unblocked				0.92	0.64	0.92
vC, conflicting volume				564	1586	558
vC1, stage 1 conf vol						
vC2, stage 2 conf vol						
vCu, unblocked vol				481	1346	475
tC, single (s)				4.1	6.4	6.2
tC, 2 stage (s)						
tF (s)				2.2	3.5	3.3
p0 queue free %				95	89	95
cM capacity (veh/h)				1003	102	545
<b>Direction, Lane #</b>	<b>EB 1</b>	<b>WB 1</b>	<b>NB 1</b>			
Volume Total	564	978	40			
Volume Left	0	49	11			
Volume Right	11	0	29			
cSH	1700	1003	248			
Volume to Capacity	0.33	0.05	0.16			
Queue Length 95th (m)	0.0	1.2	4.3			
Control Delay (s)	0.0	1.3	22.2			
Lane LOS	A		C			
Approach Delay (s)	0.0	1.3	22.2			
Approach LOS	C					
<b>Intersection Summary</b>						
Average Delay	1.4					
Intersection Capacity Utilization	90.7%			ICU Level of Service	E	
Analysis Period (min)	15					





















HCM Signalized Intersection Capacity Analysis  
9: Richmond Rd & Carling Ave

Existing (2019)  
PM Peak Hour

													
Movement	EBL	EBT	EBR	WBL	WBT	WBR	NBL	NBT	NBR	SBL	SBT	SBR	
Lane Configurations													
Traffic Volume (vph)	228	632	2	12	1705	1	0	407	461	0	691	320	
Future Volume (vph)	228	632	2	12	1705	1	0	407	461	0	691	320	
Ideal Flow (vphpl)	1800	1800	1800	1800	1800	1800	1800	1800	1800	1800	1800	1800	
Total Lost time (s)	6.0	5.8		6.0	5.8			7.0	4.0		7.0	4.0	
Lane Util. Factor	1.00	0.95		1.00	0.91			0.95	1.00		0.95	1.00	
Frpb, ped/bikes	1.00	1.00		1.00	1.00			1.00	0.99		1.00	0.99	
Flpb, ped/bikes	1.00	1.00		1.00	1.00			1.00	1.00		1.00	1.00	
Frt	1.00	1.00		1.00	1.00			1.00	0.85		1.00	0.85	
Flt Protected	0.95	1.00		0.95	1.00			1.00	1.00		1.00	1.00	
Satd. Flow (prot)	1695	3389		988	4919			3390	1496		3357	1497	
Flt Permitted	0.95	1.00		0.95	1.00			1.00	1.00		1.00	1.00	
Satd. Flow (perm)	1695	3389		988	4919			3390	1496		3357	1497	
Peak-hour factor, PHF	0.90	0.90	0.90	0.90	0.90	0.90	0.90	0.90	0.90	0.90	0.90	0.90	
Adj. Flow (vph)	253	702	2	13	1894	1	0	452	512	0	768	356	
RTOR Reduction (vph)	0	0	0	0	0	0	0	0	0	0	0	0	
Lane Group Flow (vph)	253	704	0	13	1895	0	0	452	512	0	768	356	
Confl. Peds. (#/hr)	7		2	2		7	2		3	3		2	
Confl. Bikes (#/hr)	7		2	2		7	2		3	3		2	
Heavy Vehicles (%)	2%	2%	0%	75%	1%	0%	2%	2%	2%	2%	3%	2%	
Turn Type	Prot	NA		Prot	NA			NA	Free		NA	Free	
Protected Phases	5	2		19	6			8			4		
Permitted Phases									Free			Free	
Actuated Green, G (s)	22.4	63.9		6.0	53.5			35.3	130.0		35.3	130.0	
Effective Green, g (s)	22.4	63.9		6.0	53.5			35.3	130.0		35.3	130.0	
Actuated g/C Ratio	0.17	0.49		0.05	0.41			0.27	1.00		0.27	1.00	
Clearance Time (s)	6.0	5.8			5.8			7.0			7.0		
Vehicle Extension (s)	3.0	3.0			3.0			3.0			3.0		
Lane Grp Cap (vph)	292	1665		45	2024			920	1496		911	1497	
v/s Ratio Prot	c0.15	0.21		0.01	c0.39			0.13			c0.23		
v/s Ratio Perm									0.34			0.24	
v/c Ratio	0.87	0.42		0.29	0.94			0.49	0.34		0.84	0.24	
Uniform Delay, d1	52.3	21.2		59.9	36.6			39.8	0.0		44.7	0.0	
Progression Factor	1.00	1.00		0.91	0.63			1.00	1.00		1.00	1.00	
Incremental Delay, d2	22.6	0.8		3.0	8.4			0.4	0.6		7.2	0.4	
Delay (s)	74.9	22.0		57.6	31.6			40.2	0.6		51.9	0.4	
Level of Service	E	C		E	C			D	A		D	A	
Approach Delay (s)		36.0			31.8			19.2			35.6		
Approach LOS		D			C			B			D		
<b>Intersection Summary</b>													
HCM 2000 Control Delay			31.0									HCM 2000 Level of Service	C
HCM 2000 Volume to Capacity ratio			0.94										
Actuated Cycle Length (s)			130.0									Sum of lost time (s)	24.8
Intersection Capacity Utilization			84.8%									ICU Level of Service	E
Analysis Period (min)			15										
c Critical Lane Group													

HCM Signalized Intersection Capacity Analysis  
10: Poulin St & Richmond Rd

Existing (2019)  
PM Peak Hour

													
Movement	EBL	EBT	EBR	WBL	WBT	WBR	NBL	NBT	NBR	SBL	SBT	SBR	
Lane Configurations													
Traffic Volume (vph)	204	431	2	0	851	41	38	54	12	66	1	122	
Future Volume (vph)	204	431	2	0	851	41	38	54	12	66	1	122	
Ideal Flow (vphpl)	1800	1800	1800	1800	1800	1800	1800	1800	1800	1800	1800	1800	
Total Lost time (s)	6.3	6.3			6.3			6.2			6.2	6.2	
Lane Util. Factor	1.00	1.00			0.95			1.00			1.00	1.00	
Frbp, ped/bikes	1.00	1.00			1.00			0.99			1.00	0.98	
Flpb, ped/bikes	1.00	1.00			1.00			1.00			0.99	1.00	
Frt	1.00	1.00			0.99			0.98			1.00	0.85	
Flt Protected	0.95	1.00			1.00			0.98			0.95	1.00	
Satd. Flow (prot)	1729	1818			3428			1750			1721	1520	
Flt Permitted	0.19	1.00			1.00			0.85			0.66	1.00	
Satd. Flow (perm)	354	1818			3428			1512			1194	1520	
Peak-hour factor, PHF	0.90	0.90	0.90	0.90	0.90	0.90	0.90	0.90	0.90	0.90	0.90	0.90	
Adj. Flow (vph)	227	479	2	0	946	46	42	60	13	73	1	136	
RTOR Reduction (vph)	0	0	0	0	3	0	0	6	0	0	0	117	
Lane Group Flow (vph)	227	481	0	0	989	0	0	109	0	0	74	19	
Confl. Peds. (#/hr)	6		16	16		6	2		6	6		2	
Confl. Bikes (#/hr)	6		16	16		6	2		6	6		2	
Heavy Vehicles (%)	0%	0%	0%	2%	0%	0%	0%	0%	0%	0%	0%	0%	
Turn Type	pm+pt	NA			NA		Perm	NA		Perm	NA	Perm	
Protected Phases	5	2			6			8			4		
Permitted Phases	2						8		4			4	
Actuated Green, G (s)	65.1	65.1			47.2			12.4			12.4	12.4	
Effective Green, g (s)	65.1	65.1			47.2			12.4			12.4	12.4	
Actuated g/C Ratio	0.72	0.72			0.52			0.14			0.14	0.14	
Clearance Time (s)	6.3	6.3			6.3			6.2			6.2	6.2	
Vehicle Extension (s)	3.0	3.0			3.0			3.0			3.0	3.0	
Lane Grp Cap (vph)	433	1315			1797			208			164	209	
v/s Ratio Prot	c0.07	0.26			0.29								
v/s Ratio Perm	c0.31							c0.07			0.06	0.01	
v/c Ratio	0.52	0.37			0.55			0.52			0.45	0.09	
Uniform Delay, d1	7.0	4.7			14.3			36.1			35.7	33.9	
Progression Factor	1.00	1.00			1.00			1.00			1.00	1.00	
Incremental Delay, d2	1.1	0.8			1.2			2.4			2.0	0.2	
Delay (s)	8.1	5.5			15.5			38.4			37.6	34.1	
Level of Service	A	A			B			D			D	C	
Approach Delay (s)		6.3			15.5			38.4			35.3		
Approach LOS		A			B			D			D		
<b>Intersection Summary</b>													
HCM 2000 Control Delay			15.7									HCM 2000 Level of Service	B
HCM 2000 Volume to Capacity ratio			0.55										
Actuated Cycle Length (s)			90.0									Sum of lost time (s)	18.8
Intersection Capacity Utilization			68.3%									ICU Level of Service	C
Analysis Period (min)			15										
c Critical Lane Group													

## Appendix E – Intersection Collision Diagrams



# COLLISION DIAGRAM

LOCATION: Alpine Avenue and Carling Avenue  
 CITY: Ottawa, ON  
 PERIOD: January 2014 to December 2018

DATE: Nov 11, 2019  
 PREPARED BY: M.C.

## 1460 Richmond



Carling Avenue

Carling Avenue

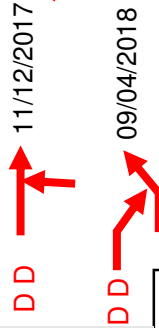
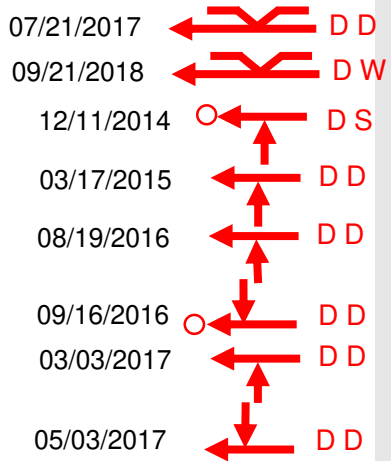
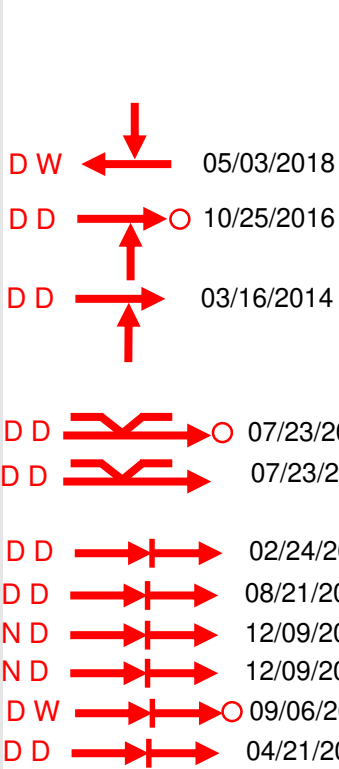
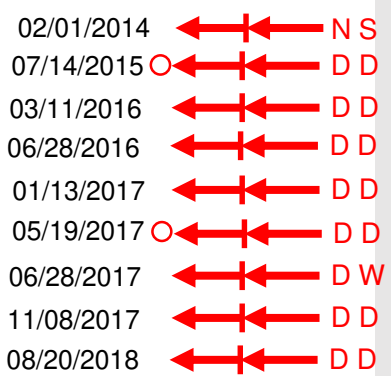
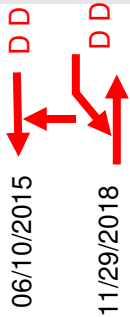

## Alpine Avenue

### LEGEND

- Vehicle Path
- Pedestrian Path
- Fixed Object
- Personal Injury
- Fatality

- Rear-end Collision
- Head-on Collision
- Side Swipe
- Out Of Control
- Right-turning Vehicle
- Left-turning Vehicle

### Conditions

**D W**

### Time of Day

- D – Daytime
- N – Nighttime

### Roadway

- D – Dry
- I – Icy
- W – Wet
- S – Snow



# COLLISION DIAGRAM

LOCATION: Richmond Road and Carling Avenue  
 CITY: Ottawa, ON  
 PERIOD: January 2014 to December 2018

DATE: June 16, 2020  
 PREPARED BY: M.C.

## Richmond Road



Carling Avenue

Carling Avenue

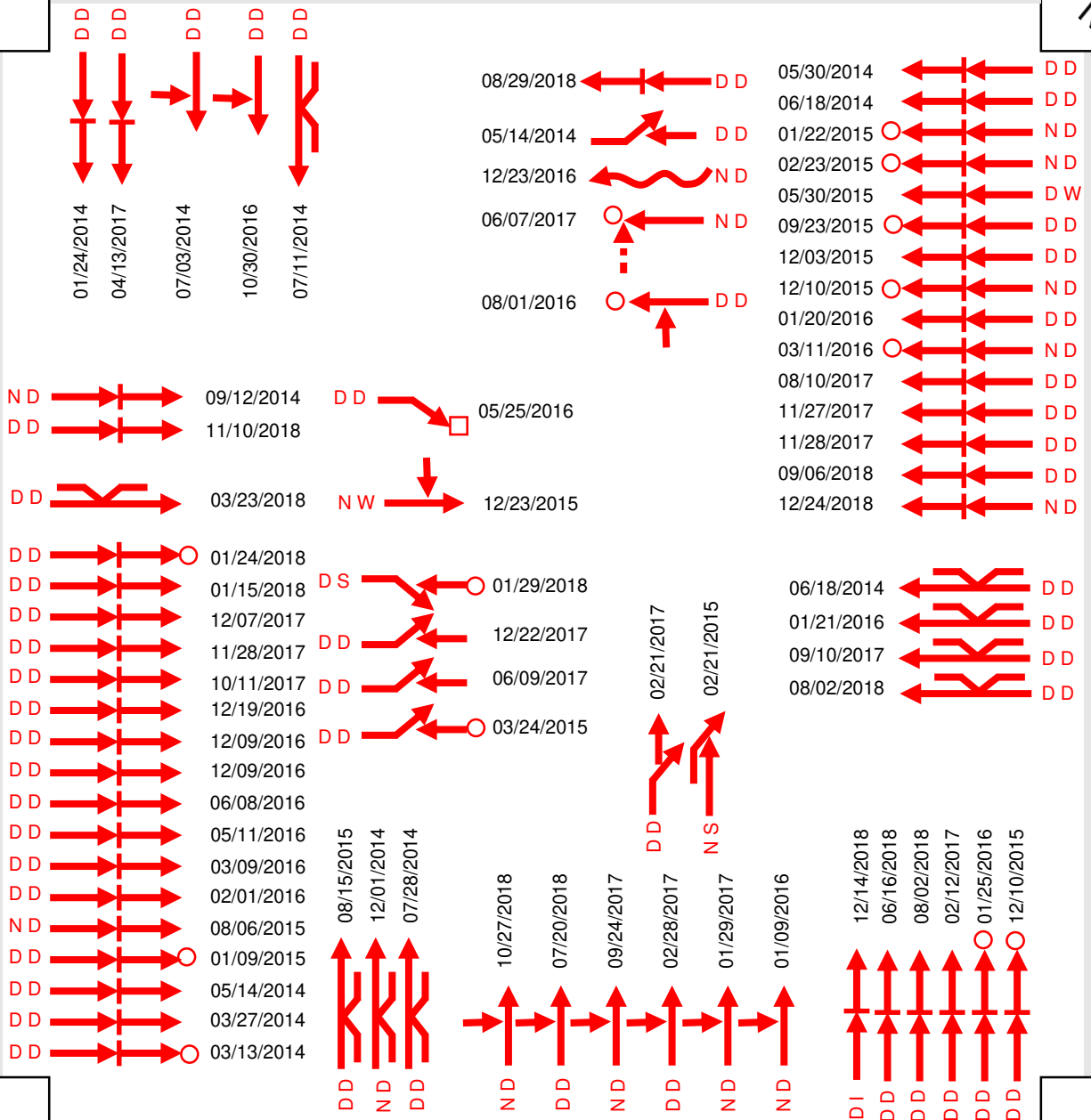

### LEGEND

- Vehicle Path
- Pedestrian Path
- Fixed Object
- Personal Injury
- Fatality

- Rear-end Collision
- Head-on Collision
- Side Swipe
- Out Of Control
- Right-turning Vehicle
- Left-turning Vehicle

Conditions  
**D W**

Time of Day      Roadway

D – Daytime      D – Dry      W – Wet  
 N – Nighttime    I – Icy      S – Snow



# COLLISION DIAGRAM

LOCATION: Richmond Road and Poulin Avenue  
 CITY: Ottawa, ON  
 PERIOD: January 2014 to December 2018

DATE: June 16, 2020  
 PREPARED BY: M.C.

## Poulin Avenue



Richmond Road

Richmond Road

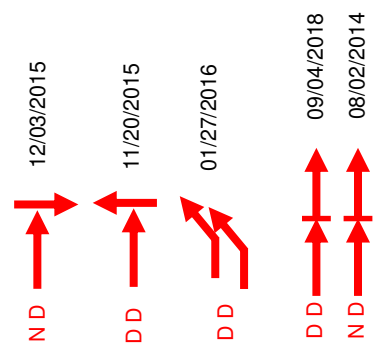
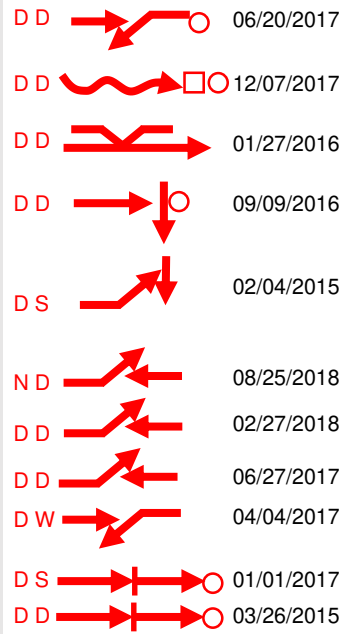
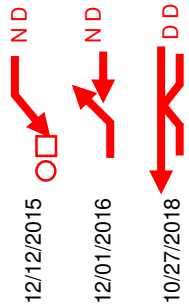

## Poulin Avenue

### LEGEND

- Vehicle Path
- Pedestrian Path
- Fixed Object
- Personal Injury
- Fatality

- Rear-end Collision
- Head-on Collision
- Side Swipe
- Out Of Control
- Right-turning Vehicle
- Left-turning Vehicle

### Conditions

**D W**

### Time of Day

- D – Daytime
- N – Nighttime

### Roadway

- D – Dry
- I – Icy
- W – Wet
- S – Snow



# COLLISION DIAGRAM

LOCATION: Croydon Avenue and Richmond Road  
 CITY: Ottawa, ON  
 PERIOD: January 2014 to December 2018

DATE: Nov 11, 2019  
 PREPARED BY: M.C.

## Croydon Avenue



Richmond Road

Richmond Road

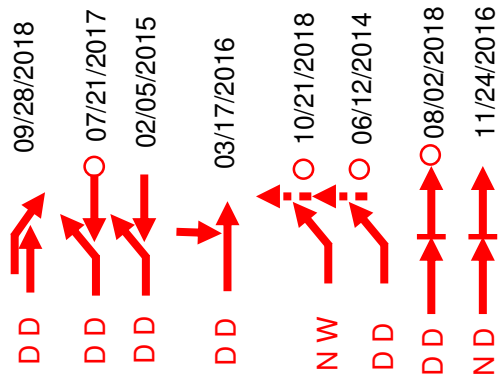
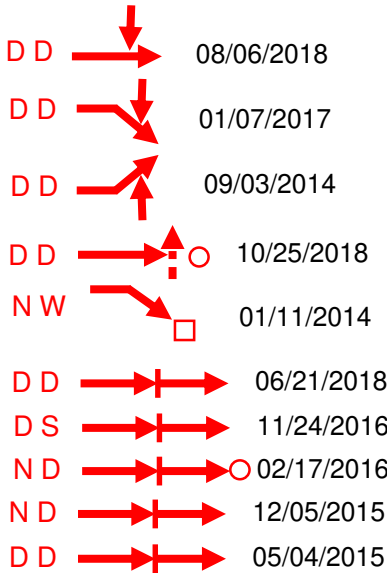
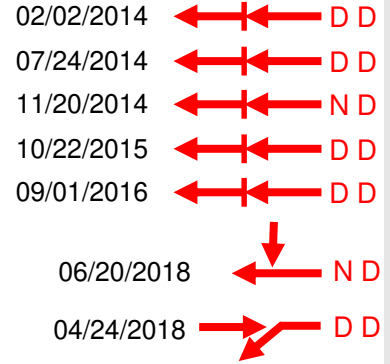
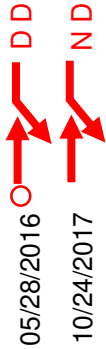

## Croydon Avenue

### LEGEND

- Vehicle Path
- Pedestrian Path
- Fixed Object
- Personal Injury
- Fatality

- Rear-end Collision
- Head-on Collision
- Side Swipe
- Out Of Control
- Right-turning Vehicle
- Left-turning Vehicle

### Conditions

D W

### Time of Day

D – Daytime  
 N – Nighttime

### Roadway

D – Dry W – Wet  
 I – Icy S – Snow





# COLLISION DIAGRAM

LOCATION: Croydon Avenue and Carling Avenue  
 CITY: Ottawa, ON  
 PERIOD: January 2014 to December 2018

DATE: Nov 11, 2019  
 PREPARED BY: M.C.

## Croydon Avenue



Carling Avenue

Carling Avenue

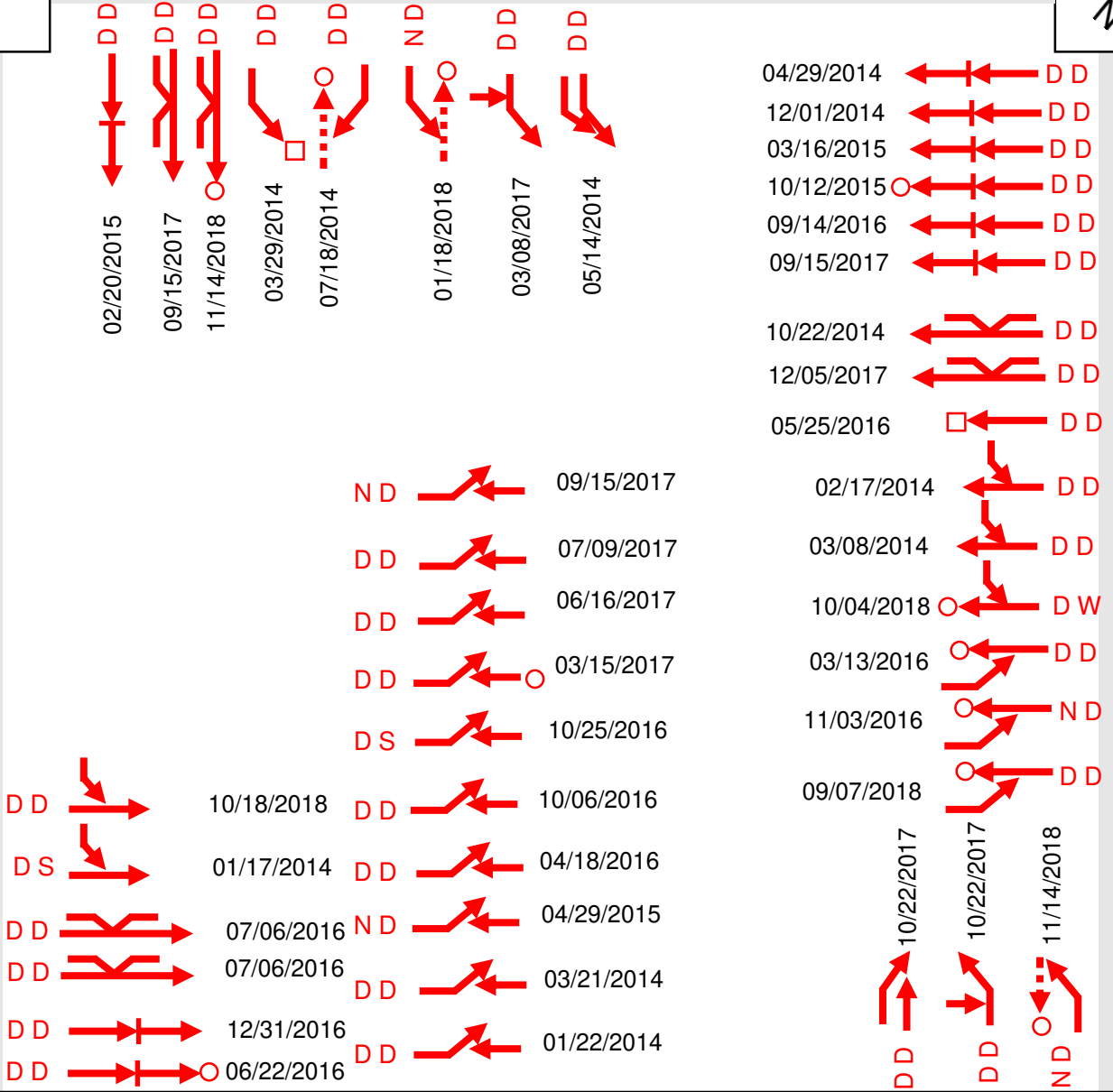

### LEGEND

- Vehicle Path
- Pedestrian Path
- Fixed Object
- Personal Injury
- Fatality

- Rear-end Collision
- Head-on Collision
- Side Swipe
- Out Of Control
- Right-turning Vehicle
- Left-turning Vehicle

### Conditions

- D W**
- Time of Day: D - Daytime, N - Nighttime
- Roadway: D - Dry, I - Icy, W - Wet, S - Snow

## Appendix F – Future Background Level of Service Outputs

HCM Signalized Intersection Capacity Analysis  
1: Croydon Ave & Richmond Rd

Future Background (2024)  
AM Peak Hour

Movement	EBL	EBT	EBR	WBL	WBT	WBR	NBL	NBT	NBR	SBL	SBT	SBR
Lane Configurations												
Traffic Volume (vph)	23	569	69	17	379	17	38	29	81	28	72	38
Future Volume (vph)	23	569	69	17	379	17	38	29	81	28	72	38
Ideal Flow (vphpl)	1800	1800	1800	1800	1800	1800	1800	1800	1800	1800	1800	1800
Lane Width	3.4	3.4	3.7	3.0	3.4	3.7	3.5	3.5	3.7	3.7	4.8	3.7
Total Lost time (s)	6.4	6.4		6.4	6.4		6.1	6.1			6.1	
Lane Util. Factor	1.00	1.00		1.00	1.00		1.00	1.00			1.00	
Frbp, ped/bikes	1.00	1.00		1.00	1.00		1.00	0.94			0.98	
Flpb, ped/bikes	0.98	1.00		0.99	1.00		0.97	1.00			0.99	
Frtp	1.00	0.98		1.00	0.99		1.00	0.89			0.96	
Fltp Protected	0.95	1.00		0.95	1.00		0.95	1.00			0.99	
Satd. Flow (prot)	1559	1572		1581	1584		1388	1390			1848	
Fltp Permitted	0.53	1.00		0.37	1.00		0.68	1.00			0.90	
Satd. Flow (perm)	867	1572		624	1584		999	1390			1680	
Peak-hour factor, PHF	1.00	1.00	1.00	1.00	1.00	1.00	1.00	1.00	1.00	1.00	1.00	1.00
Adj. Flow (vph)	23	569	69	17	379	17	38	29	81	28	72	38
RTOR Reduction (vph)	0	4	0	0	1	0	0	70	0	0	26	0
Lane Group Flow (vph)	23	634	0	17	395	0	38	40	0	0	112	0
Confl. Peds. (#/hr)	21		15	15		21	29		41	41		29
Heavy Vehicles (%)	5%	4%	15%	0%	6%	0%	18%	20%	3%	4%	0%	6%
Bus Blockages (#/hr)	0	10	0	0	10	0	0	0	0	0	0	0
Turn Type	Perm	NA		Perm	NA		Perm	NA		Perm	NA	
Protected Phases		2			6			8			4	
Permitted Phases	2			6			8			4		
Actuated Green, G (s)	48.4	48.4		48.4	48.4		9.1	9.1			9.1	
Effective Green, g (s)	48.4	48.4		48.4	48.4		9.1	9.1			9.1	
Actuated g/C Ratio	0.69	0.69		0.69	0.69		0.13	0.13			0.13	
Clearance Time (s)	6.4	6.4		6.4	6.4		6.1	6.1			6.1	
Vehicle Extension (s)	3.0	3.0		3.0	3.0		3.0	3.0			3.0	
Lane Grp Cap (vph)	599	1086		431	1095		129	180			218	
v/s Ratio Prot		c0.40			0.25			0.03				
v/s Ratio Perm	0.03			0.03			0.04				c0.07	
v/c Ratio	0.04	0.58		0.04	0.36		0.29	0.22			0.51	
Uniform Delay, d1	3.4	5.6		3.4	4.4		27.5	27.3			28.4	
Progression Factor	1.00	1.00		1.00	1.00		1.00	1.00			1.00	
Incremental Delay, d2	0.1	2.3		0.2	0.9		1.3	0.6			2.0	
Delay (s)	3.5	7.9		3.6	5.4		28.8	27.9			30.4	
Level of Service	A	A		A	A		C	C			C	
Approach Delay (s)		7.7			5.3			28.1			30.4	
Approach LOS		A			A			C			C	
<b>Intersection Summary</b>												
HCM 2000 Control Delay			11.5				HCM 2000 Level of Service				B	
HCM 2000 Volume to Capacity ratio			0.57									
Actuated Cycle Length (s)			70.0				Sum of lost time (s)				12.5	
Intersection Capacity Utilization			65.4%				ICU Level of Service				C	
Analysis Period (min)			15									

c Critical Lane Group

HCM Signalized Intersection Capacity Analysis  
 2: Alpine Ave/1460 Richmond & Carling Ave

Future Background (2024)  
 AM Peak Hour



Movement	EBL	EBT	EBR	WBL	WBT	WBR	NBL	NBT	NBR	SBL	SBT	SBR	
Lane Configurations	↗	↑↑↑		↗	↑↑↑			↕			↕		
Traffic Volume (vph)	33	2751	6	34	947	76	25	8	97	41	9	52	
Future Volume (vph)	33	2751	6	34	947	76	25	8	97	41	9	52	
Ideal Flow (vphpl)	1800	1800	1800	1800	1800	1800	1800	1800	1800	1800	1800	1800	
Lane Width	3.0	3.6	3.7	3.0	3.7	3.7	3.7	4.8	3.7	3.7	3.6	3.7	
Total Lost time (s)	5.9	5.9		5.9	5.9			6.7			6.7		
Lane Util. Factor	1.00	0.91		1.00	0.91			1.00			1.00		
Frbp, ped/bikes	1.00	1.00		1.00	0.99			0.96			0.99		
Flpb, ped/bikes	0.98	1.00		1.00	1.00			1.00			0.99		
Frnt	1.00	1.00		1.00	0.99			0.90			0.93		
Flt Protected	0.95	1.00		0.95	1.00			0.99			0.98		
Satd. Flow (prot)	1504	4764		1596	4642			1674			1570		
Flt Permitted	0.27	1.00		0.04	1.00			0.89			0.67		
Satd. Flow (perm)	424	4764		67	4642			1501			1065		
Peak-hour factor, PHF	1.00	1.00	1.00	1.00	1.00	1.00	1.00	1.00	1.00	1.00	1.00	1.00	
Adj. Flow (vph)	33	2751	6	34	947	76	25	8	97	41	9	52	
RTOR Reduction (vph)	0	0	0	0	4	0	0	68	0	0	36	0	
Lane Group Flow (vph)	33	2757	0	34	1019	0	0	62	0	0	66	0	
Confl. Peds. (#/hr)	36		27	27		36	11		27	27		11	
Heavy Vehicles (%)	4%	2%	0%	0%	4%	3%	10%	0%	3%	3%	0%	2%	
Bus Blockages (#/hr)	0	8	0	0	8	0	0	0	0	0	0	0	
Turn Type	Perm	NA		pm+pt	NA		Perm	NA		Perm	NA		
Protected Phases		2		1	6			8			4		
Permitted Phases	2			6			8			4			
Actuated Green, G (s)	94.8	94.8		104.5	104.5			12.9			12.9		
Effective Green, g (s)	94.8	94.8		104.5	104.5			12.9			12.9		
Actuated g/C Ratio	0.73	0.73		0.80	0.80			0.10			0.10		
Clearance Time (s)	5.9	5.9		5.9	5.9			6.7			6.7		
Vehicle Extension (s)	3.0	3.0		3.0	3.0			3.0			3.0		
Lane Grp Cap (vph)	309	3474		98	3731			148			105		
v/s Ratio Prot		c0.58		0.01	c0.22								
v/s Ratio Perm	0.08			0.27				0.04			c0.06		
v/c Ratio	0.11	0.79		0.35	0.27			0.42			0.63		
Uniform Delay, d1	5.2	11.3		13.4	3.2			55.0			56.2		
Progression Factor	0.56	0.51		3.70	0.84			1.00			1.00		
Incremental Delay, d2	0.5	1.3		2.1	0.2			1.9			11.2		
Delay (s)	3.4	7.1		51.6	2.9			57.0			67.4		
Level of Service	A	A		D	A			E			E		
Approach Delay (s)		7.0			4.5			57.0			67.4		
Approach LOS		A			A			E			E		
<b>Intersection Summary</b>													
HCM 2000 Control Delay			9.5									HCM 2000 Level of Service	A
HCM 2000 Volume to Capacity ratio			0.76										
Actuated Cycle Length (s)			130.0									Sum of lost time (s)	18.5
Intersection Capacity Utilization			84.6%									ICU Level of Service	E
Analysis Period (min)			15										

c Critical Lane Group

# HCM Signalized Intersection Capacity Analysis

## 3: Carling Ave & Croydon Ave

Future Background (2024)  
AM Peak Hour



Movement	EBL	EBT	WBT	WBR	SBL	SBR
Lane Configurations	↵	↑↑↑	↑↑↑		↵↵	
Traffic Volume (vph)	106	2253	930	98	173	28
Future Volume (vph)	106	2253	930	98	173	28
Ideal Flow (vphpl)	1800	1800	1800	1800	1800	1800
Lane Width	2.8	3.6	3.7	3.7	3.7	3.3
Total Lost time (s)	5.9	5.9	5.9		6.3	
Lane Util. Factor	1.00	0.91	0.91		0.97	
Frpb, ped/bikes	1.00	1.00	0.99		1.00	
Flpb, ped/bikes	1.00	1.00	1.00		1.00	
Frt	1.00	1.00	0.99		0.98	
Flt Protected	0.95	1.00	1.00		0.96	
Satd. Flow (prot)	1525	4696	4589		3111	
Flt Permitted	0.24	1.00	1.00		0.96	
Satd. Flow (perm)	382	4696	4589		3111	
Peak-hour factor, PHF	1.00	1.00	1.00	1.00	1.00	1.00
Adj. Flow (vph)	106	2253	930	98	173	28
RTOR Reduction (vph)	0	0	7	0	12	0
Lane Group Flow (vph)	106	2253	1021	0	189	0
Confl. Peds. (#/hr)	16			16	2	19
Heavy Vehicles (%)	2%	2%	3%	7%	7%	0%
Bus Blockages (#/hr)	0	19	19	0	0	0
Turn Type	pm+pt	NA	NA		Prot	
Protected Phases	5	2	6		7	
Permitted Phases	2					
Actuated Green, G (s)	104.4	104.4	91.0		13.4	
Effective Green, g (s)	104.4	104.4	91.0		13.4	
Actuated g/C Ratio	0.80	0.80	0.70		0.10	
Clearance Time (s)	5.9	5.9	5.9		6.3	
Vehicle Extension (s)	3.0	3.0	3.0		3.0	
Lane Grp Cap (vph)	372	3771	3212		320	
v/s Ratio Prot	0.02	c0.48	0.22		c0.06	
v/s Ratio Perm	0.21					
v/c Ratio	0.28	0.60	0.32		0.59	
Uniform Delay, d1	3.3	4.8	7.5		55.7	
Progression Factor	0.59	0.35	1.00		1.00	
Incremental Delay, d2	0.3	0.5	0.3		2.9	
Delay (s)	2.2	2.2	7.8		58.6	
Level of Service	A	A	A		E	
Approach Delay (s)		2.2	7.8		58.6	
Approach LOS		A	A		E	

### Intersection Summary

HCM 2000 Control Delay	6.9	HCM 2000 Level of Service	A
HCM 2000 Volume to Capacity ratio	0.63		
Actuated Cycle Length (s)	130.0	Sum of lost time (s)	18.1
Intersection Capacity Utilization	72.7%	ICU Level of Service	C
Analysis Period (min)	15		

c Critical Lane Group

# HCM Unsignalized Intersection Capacity Analysis

## 4: Carling Ave & Forest St

Future Background (2024)  
AM Peak Hour

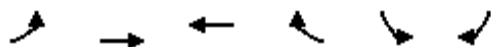

Movement	EBL	EBT	WBT	WBR	SBL	SBR	
Lane Configurations		↑↑↑	↑↑↑			↑	
Traffic Volume (veh/h)	0	2892	1002	25	0	53	
Future Volume (Veh/h)	0	2892	1002	25	0	53	
Sign Control		Free	Free		Stop		
Grade		0%	0%		0%		
Peak Hour Factor	1.00	1.00	1.00	1.00	1.00	1.00	
Hourly flow rate (vph)	0	2892	1002	25	0	53	
<b>Pedestrians</b>							
Lane Width (m)							
Walking Speed (m/s)							
Percent Blockage							
Right turn flare (veh)							
Median type		None	None				
Median storage (veh)							
Upstream signal (m)		55	141				
pX, platoon unblocked	0.93				0.65	0.93	
vC, conflicting volume	1027				1978	346	
vC1, stage 1 conf vol							
vC2, stage 2 conf vol							
vCu, unblocked vol	782				0	54	
tC, single (s)	4.1				6.8	6.9	
tC, 2 stage (s)							
tF (s)	2.2				3.5	3.3	
p0 queue free %	100				100	94	
cM capacity (veh/h)	789				668	942	
<b>Direction, Lane #</b>	<b>EB 1</b>	<b>EB 2</b>	<b>EB 3</b>	<b>WB 1</b>	<b>WB 2</b>	<b>WB 3</b>	<b>SB 1</b>
Volume Total	964	964	964	401	401	225	53
Volume Left	0	0	0	0	0	0	0
Volume Right	0	0	0	0	0	25	53
cSH	1700	1700	1700	1700	1700	1700	942
Volume to Capacity	0.57	0.57	0.57	0.24	0.24	0.13	0.06
Queue Length 95th (m)	0.0	0.0	0.0	0.0	0.0	0.0	1.4
Control Delay (s)	0.0	0.0	0.0	0.0	0.0	0.0	9.0
Lane LOS							A
Approach Delay (s)	0.0			0.0			9.0
Approach LOS							A
<b>Intersection Summary</b>							
Average Delay			0.1				
Intersection Capacity Utilization			62.3%		ICU Level of Service		B
Analysis Period (min)			15				

HCM Unsignalized Intersection Capacity Analysis  
5: Croydon Ave & Bond St









Future Background (2024)  
AM Peak Hour



Movement	EBL	EBR	NBL	NBT	SBT	SBR
Lane Configurations						
Traffic Volume (veh/h)	2	10	10	193	190	10
Future Volume (Veh/h)	2	10	10	193	190	10
Sign Control	Stop			Free	Free	
Grade	0%			0%	0%	
Peak Hour Factor	1.00	1.00	1.00	1.00	1.00	1.00
Hourly flow rate (vph)	2	10	10	193	190	10
<b>Pedestrians</b>						
Lane Width (m)						
Walking Speed (m/s)						
Percent Blockage						
Right turn flare (veh)						
Median type				None	None	
Median storage (veh)						
Upstream signal (m)				78	181	
pX, platoon unblocked						
vC, conflicting volume	408	195	200			
vC1, stage 1 conf vol						
vC2, stage 2 conf vol						
vCu, unblocked vol	408	195	200			
tC, single (s)	6.4	6.2	4.1			
tC, 2 stage (s)						
tF (s)	3.5	3.3	2.2			
p0 queue free %	100	99	99			
cM capacity (veh/h)	599	851	1384			
<b>Direction, Lane #</b>	<b>EB 1</b>	<b>NB 1</b>	<b>SB 1</b>			
Volume Total	12	203	200			
Volume Left	2	10	0			
Volume Right	10	0	10			
cSH	796	1384	1700			
Volume to Capacity	0.02	0.01	0.12			
Queue Length 95th (m)	0.3	0.2	0.0			
Control Delay (s)	9.6	0.4	0.0			
Lane LOS	A	A				
Approach Delay (s)	9.6	0.4	0.0			
Approach LOS	A					
<b>Intersection Summary</b>						
Average Delay			0.5			
Intersection Capacity Utilization			29.3%	ICU Level of Service	A	
Analysis Period (min)			15			

HCM Unsignalized Intersection Capacity Analysis  
6: Forest St & Bond St

Future Background (2024)  
AM Peak Hour

						
Movement	WBL	WBR	NBT	NBR	SBL	SBT
Lane Configurations						
Traffic Volume (veh/h)	2	7	25	2	14	52
Future Volume (Veh/h)	2	7	25	2	14	52
Sign Control	Stop		Free		Free	
Grade	0%		0%		0%	
Peak Hour Factor	1.00	1.00	1.00	1.00	1.00	1.00
Hourly flow rate (vph)	2	7	25	2	14	52
<b>Pedestrians</b>						
Lane Width (m)						
Walking Speed (m/s)						
Percent Blockage						
Right turn flare (veh)						
Median type	None			None		
Median storage (veh)						
Upstream signal (m)						
pX, platoon unblocked						
vC, conflicting volume	106	26			27	
vC1, stage 1 conf vol						
vC2, stage 2 conf vol						
vCu, unblocked vol	106	26			27	
tC, single (s)	6.4	6.2			4.1	
tC, 2 stage (s)						
tF (s)	3.5	3.3			2.2	
p0 queue free %	100	99			99	
cM capacity (veh/h)	889	1056			1600	
<b>Direction, Lane #</b>	<b>WB 1</b>	<b>NB 1</b>	<b>SB 1</b>			
Volume Total	9	27	66			
Volume Left	2	0	14			
Volume Right	7	2	0			
cSH	1013	1700	1600			
Volume to Capacity	0.01	0.02	0.01			
Queue Length 95th (m)	0.2	0.0	0.2			
Control Delay (s)	8.6	0.0	1.6			
Lane LOS	A		A			
Approach Delay (s)	8.6	0.0	1.6			
Approach LOS	A					
<b>Intersection Summary</b>						
Average Delay			1.8			
Intersection Capacity Utilization			20.4%	ICU Level of Service	A	
Analysis Period (min)			15			



HCM Unsignalized Intersection Capacity Analysis  
7: Forest St & Richmond Rd



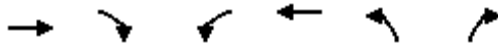

















Future Background (2024)  
AM Peak Hour



Movement	EBT	EBR	WBL	WBT	NBL	NBR
Lane Configurations	→			←	←	←
Traffic Volume (veh/h)	628	12	24	431	12	33
Future Volume (Veh/h)	628	12	24	431	12	33
Sign Control	Free			Free	Stop	
Grade	0%			0%	0%	
Peak Hour Factor	1.00	1.00	1.00	1.00	1.00	1.00
Hourly flow rate (vph)	628	12	24	431	12	33
Pedestrians						
Lane Width (m)						
Walking Speed (m/s)						
Percent Blockage						
Right turn flare (veh)						
Median type	None			None		
Median storage veh						
Upstream signal (m)	279			154		
pX, platoon unblocked				0.90	0.94	0.90
vC, conflicting volume				640	1113	634
vC1, stage 1 conf vol						
vC2, stage 2 conf vol						
vCu, unblocked vol				548	925	541
tC, single (s)				4.1	6.4	6.2
tC, 2 stage (s)						
tF (s)				2.2	3.5	3.3
p0 queue free %				97	96	93
cM capacity (veh/h)				932	275	492
Direction, Lane #	EB 1	WB 1	NB 1			
Volume Total	640	455	45			
Volume Left	0	24	12			
Volume Right	12	0	33			
cSH	1700	932	407			
Volume to Capacity	0.38	0.03	0.11			
Queue Length 95th (m)	0.0	0.6	2.8			
Control Delay (s)	0.0	0.8	15.0			
Lane LOS	A		B			
Approach Delay (s)	0.0	0.8	15.0			
Approach LOS	B					
Intersection Summary						
Average Delay	0.9					
Intersection Capacity Utilization	54.6%			ICU Level of Service	A	
Analysis Period (min)	15					

HCM Signalized Intersection Capacity Analysis  
 9: Richmond Rd & Carling Ave





















Future Background (2024)  
 AM Peak Hour

												
Movement	EBL	EBT	EBR	WBL	WBT	WBR	NBL	NBT	NBR	SBL	SBT	SBR
Lane Configurations												
Traffic Volume (vph)	163	1549	0	5	1001	0	0	544	1240	0	310	197
Future Volume (vph)	163	1549	0	5	1001	0	0	544	1240	0	310	197
Ideal Flow (vphpl)	1800	1800	1800	1800	1800	1800	1800	1800	1800	1800	1800	1800
Total Lost time (s)	6.0	5.8		6.0	5.8			7.0	4.0		7.0	4.0
Lane Util. Factor	1.00	0.95		1.00	0.91			0.95	1.00		0.95	1.00
Frbp, ped/bikes	1.00	1.00		1.00	1.00			1.00	0.99		1.00	0.98
Flpb, ped/bikes	1.00	1.00		1.00	1.00			1.00	1.00		1.00	1.00
Frt	1.00	1.00		1.00	1.00			1.00	0.85		1.00	0.85
Flt Protected	0.95	1.00		0.95	1.00			1.00	1.00		1.00	1.00
Satd. Flow (prot)	1679	3369		864	4772			3325	1495		3325	1479
Flt Permitted	0.95	1.00		0.95	1.00			1.00	1.00		1.00	1.00
Satd. Flow (perm)	1679	3369		864	4772			3325	1495		3325	1479
Peak-hour factor, PHF	1.00	1.00	1.00	1.00	1.00	1.00	1.00	1.00	1.00	1.00	1.00	1.00
Adj. Flow (vph)	163	1549	0	5	1001	0	0	544	1240	0	310	197
RTOR Reduction (vph)	0	0	0	0	0	0	0	0	0	0	0	0
Lane Group Flow (vph)	163	1549	0	5	1001	0	0	544	1240	0	310	197
Confl. Peds. (#/hr)	8		7	7		8	6		4	4		6
Confl. Bikes (#/hr)	8		7	7		8	6		4	4		6
Heavy Vehicles (%)	3%	1%	0%	100%	3%	0%	0%	4%	2%	0%	4%	3%
Bus Blockages (#/hr)	0	8	0	0	8	0	0	0	0	0	0	0
Turn Type	Prot	NA		Prot	NA			NA	Free		NA	Free
Protected Phases	5	2		19	6			8			4	
Permitted Phases									Free			Free
Actuated Green, G (s)	17.6	63.2		3.0	54.6			39.0	130.0		39.0	130.0
Effective Green, g (s)	17.6	63.2		3.0	54.6			39.0	130.0		39.0	130.0
Actuated g/C Ratio	0.14	0.49		0.02	0.42			0.30	1.00		0.30	1.00
Clearance Time (s)	6.0	5.8			5.8			7.0			7.0	
Vehicle Extension (s)	3.0	3.0			3.0			3.0			3.0	
Lane Grp Cap (vph)	227	1637		19	2004			997	1495		997	1479
v/s Ratio Prot	0.10	c0.46		0.01	0.21			0.16			0.09	
v/s Ratio Perm									c0.83			0.13
v/c Ratio	0.72	0.95		0.26	0.50			0.55	0.83		0.31	0.13
Uniform Delay, d1	53.8	31.8		62.4	27.7			38.1	0.0		35.1	0.0
Progression Factor	1.00	1.00		1.08	0.80			1.00	1.00		0.92	1.00
Incremental Delay, d2	10.3	12.7		7.2	0.9			2.1	5.5		0.2	0.2
Delay (s)	64.2	44.5		74.6	23.0			40.2	5.5		32.6	0.2
Level of Service	E	D		E	C			D	A		C	A
Approach Delay (s)		46.4			23.2			16.1			20.0	
Approach LOS		D			C			B			C	
<b>Intersection Summary</b>												
HCM 2000 Control Delay			28.3									C
HCM 2000 Volume to Capacity ratio			1.05									
Actuated Cycle Length (s)			130.0									24.8
Intersection Capacity Utilization			101.7%									G
Analysis Period (min)			15									

c Critical Lane Group

HCM Signalized Intersection Capacity Analysis  
10: Poulin St & Richmond Rd

Future Background (2024)  
AM Peak Hour

												
Movement	EBL	EBT	EBR	WBL	WBT	WBR	NBL	NBT	NBR	SBL	SBT	SBR
Lane Configurations												
Traffic Volume (vph)	133	571	3	0	415	30	3	20	4	76	0	90
Future Volume (vph)	133	571	3	0	415	30	3	20	4	76	0	90
Ideal Flow (vphpl)	1800	1800	1800	1800	1800	1800	1800	1800	1800	1800	1800	1800
Total Lost time (s)	6.3	6.3			6.3			6.2			6.2	6.2
Lane Util. Factor	1.00	1.00			0.95			1.00			1.00	1.00
Frbp, ped/bikes	1.00	1.00			1.00			0.99			1.00	0.96
Flpb, ped/bikes	0.99	1.00			1.00			1.00			0.99	1.00
Frt	1.00	1.00			0.99			0.98			1.00	0.85
Flt Protected	0.95	1.00			1.00			0.99			0.95	1.00
Satd. Flow (prot)	1623	1732			3286			1676			1452	1421
Flt Permitted	0.49	1.00			1.00			0.97			0.74	1.00
Satd. Flow (perm)	844	1732			3286			1632			1130	1421
Peak-hour factor, PHF	1.00	1.00	1.00	1.00	1.00	1.00	1.00	1.00	1.00	1.00	1.00	1.00
Adj. Flow (vph)	133	571	3	0	415	30	3	20	4	76	0	90
RTOR Reduction (vph)	0	0	0	0	3	0	0	4	0	0	0	80
Lane Group Flow (vph)	133	574	0	0	442	0	0	23	0	0	76	10
Confl. Peds. (#/hr)	10		5	5		10	7		4	4		7
Confl. Bikes (#/hr)	10		5	5		10	7		4	4		7
Heavy Vehicles (%)	5%	5%	0%	0%	3%	15%	0%	0%	34%	18%	0%	5%
Turn Type	Perm	NA			NA		Perm	NA		Perm	NA	Perm
Protected Phases		2			6			8			4	
Permitted Phases	2						8			4		4
Actuated Green, G (s)	102.9	102.9			102.9			14.6			14.6	14.6
Effective Green, g (s)	102.9	102.9			102.9			14.6			14.6	14.6
Actuated g/C Ratio	0.79	0.79			0.79			0.11			0.11	0.11
Clearance Time (s)	6.3	6.3			6.3			6.2			6.2	6.2
Vehicle Extension (s)	3.0	3.0			3.0			3.0			3.0	3.0
Lane Grp Cap (vph)	668	1370			2600			183			126	159
v/s Ratio Prot		c0.33			0.13							
v/s Ratio Perm	0.16							0.01			c0.07	0.01
v/c Ratio	0.20	0.42			0.17			0.13			0.60	0.06
Uniform Delay, d1	3.4	4.2			3.3			52.0			54.9	51.6
Progression Factor	0.01	0.83			1.00			0.88			1.00	1.00
Incremental Delay, d2	0.6	0.8			0.1			0.3			7.9	0.2
Delay (s)	0.6	4.3			3.4			45.8			62.8	51.8
Level of Service	A	A			A			D			E	D
Approach Delay (s)		3.6			3.4			45.8			56.8	
Approach LOS		A			A			D			E	
<b>Intersection Summary</b>												
HCM 2000 Control Delay			11.0		HCM 2000 Level of Service					B		
HCM 2000 Volume to Capacity ratio			0.44									
Actuated Cycle Length (s)			130.0		Sum of lost time (s)				12.5			
Intersection Capacity Utilization			57.5%		ICU Level of Service					B		
Analysis Period (min)			15									
c Critical Lane Group												

HCM Signalized Intersection Capacity Analysis  
1: Croydon Ave & Richmond Rd

Future Background (2024)  
PM Peak Hour

Movement	EBL	EBT	EBR	WBL	WBT	WBR	NBL	NBT	NBR	SBL	SBT	SBR
Lane Configurations												
Traffic Volume (vph)	26	479	124	60	822	18	147	99	37	15	62	20
Future Volume (vph)	26	479	124	60	822	18	147	99	37	15	62	20
Ideal Flow (vphpl)	1800	1800	1800	1800	1800	1800	1800	1800	1800	1800	1800	1800
Lane Width	3.4	3.4	3.7	3.0	3.4	3.7	3.5	3.5	3.7	3.7	4.8	3.7
Total Lost time (s)	6.4	6.4		6.4	6.4		6.1	6.1			6.1	
Lane Util. Factor	1.00	1.00		1.00	1.00		1.00	1.00			1.00	
Frbp, ped/bikes	1.00	0.99		1.00	1.00		1.00	0.97			0.99	
Flpb, ped/bikes	0.99	1.00		0.98	1.00		0.96	1.00			0.99	
Frt	1.00	0.97		1.00	1.00		1.00	0.96			0.97	
Flt Protected	0.95	1.00		0.95	1.00		0.95	1.00			0.99	
Satd. Flow (prot)	1654	1563		1537	1649		1558	1635			1915	
Flt Permitted	0.24	1.00		0.38	1.00		0.76	1.00			0.94	
Satd. Flow (perm)	410	1563		607	1649		1242	1635			1811	
Peak-hour factor, PHF	1.00	1.00	1.00	1.00	1.00	1.00	1.00	1.00	1.00	1.00	1.00	1.00
Adj. Flow (vph)	26	479	124	60	822	18	147	99	37	15	62	20
RTOR Reduction (vph)	0	8	0	0	1	0	0	18	0	0	13	0
Lane Group Flow (vph)	26	595	0	60	839	0	147	118	0	0	84	0
Confl. Peds. (#/hr)	30		24	24		30	29		59	59		29
Heavy Vehicles (%)	0%	2%	8%	2%	2%	0%	4%	0%	4%	0%	0%	0%
Bus Blockages (#/hr)	0	10	0	0	10	0	0	0	0	0	0	0
Turn Type	Perm	NA		Perm	NA		Perm	NA		Perm	NA	
Protected Phases		2			6			8			4	
Permitted Phases	2			6			8			4		
Actuated Green, G (s)	56.5	56.5		56.5	56.5		16.0	16.0			16.0	
Effective Green, g (s)	56.5	56.5		56.5	56.5		16.0	16.0			16.0	
Actuated g/C Ratio	0.66	0.66		0.66	0.66		0.19	0.19			0.19	
Clearance Time (s)	6.4	6.4		6.4	6.4		6.1	6.1			6.1	
Vehicle Extension (s)	3.0	3.0		3.0	3.0		3.0	3.0			3.0	
Lane Grp Cap (vph)	272	1038		403	1096		233	307			340	
v/s Ratio Prot		0.38			c0.51			0.07				
v/s Ratio Perm	0.06			0.10			c0.12				0.05	
v/c Ratio	0.10	0.57		0.15	0.77		0.63	0.38			0.25	
Uniform Delay, d1	5.1	7.7		5.3	9.7		31.8	30.2			29.4	
Progression Factor	1.00	1.00		1.00	1.00		1.00	1.00			1.00	
Incremental Delay, d2	0.7	2.3		0.8	5.1		5.5	0.8			0.4	
Delay (s)	5.8	10.0		6.1	14.9		37.3	31.0			29.8	
Level of Service	A	B		A	B		D	C			C	
Approach Delay (s)		9.8			14.3			34.2			29.8	
Approach LOS		A			B			C			C	
<b>Intersection Summary</b>												
HCM 2000 Control Delay			16.6				HCM 2000 Level of Service				B	
HCM 2000 Volume to Capacity ratio			0.74									
Actuated Cycle Length (s)			85.0			Sum of lost time (s)				12.5		
Intersection Capacity Utilization			83.2%			ICU Level of Service				E		
Analysis Period (min)			15									

c Critical Lane Group

HCM Signalized Intersection Capacity Analysis  
 2: Alpine Ave/1460 Richmond & Carling Ave

Future Background (2024)  
 PM Peak Hour



Movement	EBL	EBT	EBR	WBL	WBT	WBR	NBL	NBT	NBR	SBL	SBT	SBR
Lane Configurations	↗	↑↑↑		↗	↑↑↑			↕			↕	
Traffic Volume (vph)	26	1223	9	51	1971	77	19	15	30	48	17	36
Future Volume (vph)	26	1223	9	51	1971	77	19	15	30	48	17	36
Ideal Flow (vphpl)	1800	1800	1800	1800	1800	1800	1800	1800	1800	1800	1800	1800
Lane Width	3.0	3.6	3.7	3.0	3.7	3.7	3.7	4.8	3.7	3.7	3.6	3.7
Total Lost time (s)	5.9	5.9		5.9	5.9			6.7			6.7	
Lane Util. Factor	1.00	0.91		1.00	0.91			1.00			1.00	
Frbp, ped/bikes	1.00	1.00		1.00	1.00			0.98			0.98	
Flpb, ped/bikes	1.00	1.00		1.00	1.00			0.99			0.99	
Frt	1.00	1.00		1.00	0.99			0.94			0.95	
Flt Protected	0.95	1.00		0.95	1.00			0.99			0.98	
Satd. Flow (prot)	1596	4760		1548	4821			1744			1609	
Flt Permitted	0.07	1.00		0.20	1.00			0.86			0.85	
Satd. Flow (perm)	121	4760		320	4821			1516			1397	
Peak-hour factor, PHF	1.00	1.00	1.00	1.00	1.00	1.00	1.00	1.00	1.00	1.00	1.00	1.00
Adj. Flow (vph)	26	1223	9	51	1971	77	19	15	30	48	17	36
RTOR Reduction (vph)	0	0	0	0	2	0	0	27	0	0	19	0
Lane Group Flow (vph)	26	1232	0	51	2046	0	0	37	0	0	82	0
Confl. Peds. (#/hr)	40		13	13		40	32		14	14		32
Heavy Vehicles (%)	0%	2%	0%	3%	1%	0%	12%	0%	4%	3%	0%	0%
Bus Blockages (#/hr)	0	8	0	0	8	0	0	0	0	0	0	0
Turn Type	pm+pt	NA		pm+pt	NA		Perm	NA		Perm	NA	
Protected Phases	5	2		1	6			8			4	
Permitted Phases	2			6			8			4		
Actuated Green, G (s)	96.3	92.5		99.3	94.0			13.7			13.7	
Effective Green, g (s)	96.3	92.5		99.3	94.0			13.7			13.7	
Actuated g/C Ratio	0.74	0.71		0.76	0.72			0.11			0.11	
Clearance Time (s)	5.9	5.9		5.9	5.9			6.7			6.7	
Vehicle Extension (s)	3.0	3.0		3.0	3.0			3.0			3.0	
Lane Grp Cap (vph)	132	3386		294	3485			159			147	
v/s Ratio Prot	0.01	0.26		c0.01	c0.42							
v/s Ratio Perm	0.14			0.13				0.02			c0.06	
v/c Ratio	0.20	0.36		0.17	0.59			0.23			0.56	
Uniform Delay, d1	6.0	7.3		4.0	8.7			53.3			55.3	
Progression Factor	1.91	1.13		1.01	0.68			1.00			1.00	
Incremental Delay, d2	0.7	0.3		0.2	0.6			0.8			4.6	
Delay (s)	12.2	8.5		4.3	6.4			54.1			59.8	
Level of Service	B	A		A	A			D			E	
Approach Delay (s)		8.6			6.4			54.1			59.8	
Approach LOS		A			A			D			E	

Intersection Summary		
HCM 2000 Control Delay	9.5	HCM 2000 Level of Service
HCM 2000 Volume to Capacity ratio	0.57	A
Actuated Cycle Length (s)	130.0	Sum of lost time (s)
Intersection Capacity Utilization	78.7%	18.5
Analysis Period (min)	15	ICU Level of Service
		D

c Critical Lane Group

HCM Signalized Intersection Capacity Analysis  
3: Carling Ave & Croydon Ave

Future Background (2024)  
PM Peak Hour

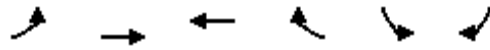

Movement	EBL	EBT	WBT	WBR	SBL	SBR
Lane Configurations	↙	↑↑↑	↑↑↑		↘↘	
Traffic Volume (vph)	88	1248	2138	142	163	106
Future Volume (vph)	88	1248	2138	142	163	106
Ideal Flow (vphpl)	1800	1800	1800	1800	1800	1800
Lane Width	2.8	3.6	3.7	3.7	3.7	3.3
Total Lost time (s)	5.9	5.9	5.9		6.3	
Lane Util. Factor	1.00	0.91	0.91		0.97	
Frpb, ped/bikes	1.00	1.00	0.99		0.98	
Flpb, ped/bikes	1.00	1.00	1.00		1.00	
Frt	1.00	1.00	0.99		0.94	
Flt Protected	0.95	1.00	1.00		0.97	
Satd. Flow (prot)	1527	4696	4701		3100	
Flt Permitted	0.04	1.00	1.00		0.97	
Satd. Flow (perm)	72	4696	4701		3100	
Peak-hour factor, PHF	1.00	1.00	1.00	1.00	1.00	1.00
Adj. Flow (vph)	88	1248	2138	142	163	106
RTOR Reduction (vph)	0	0	4	0	95	0
Lane Group Flow (vph)	88	1248	2276	0	174	0
Confl. Peds. (#/hr)	39			39	3	22
Heavy Vehicles (%)	2%	2%	1%	5%	4%	0%
Bus Blockages (#/hr)	0	19	19	0	0	0
Turn Type	pm+pt	NA	NA		Prot	
Protected Phases	5	2	6		7	
Permitted Phases	2					
Actuated Green, G (s)	104.9	104.9	90.4		12.9	
Effective Green, g (s)	104.9	104.9	90.4		12.9	
Actuated g/C Ratio	0.81	0.81	0.70		0.10	
Clearance Time (s)	5.9	5.9	5.9		6.3	
Vehicle Extension (s)	3.0	3.0	3.0		3.0	
Lane Grp Cap (vph)	154	3789	3269		307	
v/s Ratio Prot	c0.04	0.27	c0.48		c0.06	
v/s Ratio Perm	0.42					
v/c Ratio	0.57	0.33	0.70		0.57	
Uniform Delay, d1	23.0	3.3	11.7		55.9	
Progression Factor	1.75	0.40	1.00		1.00	
Incremental Delay, d2	4.8	0.2	1.3		2.4	
Delay (s)	44.9	1.5	12.9		58.3	
Level of Service	D	A	B		E	
Approach Delay (s)		4.4	12.9		58.3	
Approach LOS		A	B		E	

Intersection Summary

HCM 2000 Control Delay	13.1	HCM 2000 Level of Service	B
HCM 2000 Volume to Capacity ratio	0.67		
Actuated Cycle Length (s)	130.0	Sum of lost time (s)	18.1
Intersection Capacity Utilization	85.2%	ICU Level of Service	E
Analysis Period (min)	15		

c Critical Lane Group

HCM Unsignalized Intersection Capacity Analysis  
4: Carling Ave & Forest St

Future Background (2024)  
PM Peak Hour



Movement	EBL	EBT	WBT	WBR	SBL	SBR	
Lane Configurations		↑↑↑	↑↑↑			↑	
Traffic Volume (veh/h)	0	1300	1994	36	0	104	
Future Volume (Veh/h)	0	1300	1994	36	0	104	
Sign Control		Free	Free		Stop		
Grade		0%	0%		0%		
Peak Hour Factor	1.00	1.00	1.00	1.00	1.00	1.00	
Hourly flow rate (vph)	0	1300	1994	36	0	104	
Pedestrians							
Lane Width (m)							
Walking Speed (m/s)							
Percent Blockage							
Right turn flare (veh)							
Median type		None	None				
Median storage (veh)							
Upstream signal (m)		55	141				
pX, platoon unblocked	0.73				0.78	0.73	
vC, conflicting volume	2030				2445	683	
vC1, stage 1 conf vol							
vC2, stage 2 conf vol							
vCu, unblocked vol	1120				1023	0	
tC, single (s)	4.1				6.8	6.9	
tC, 2 stage (s)							
tF (s)	2.2				3.5	3.3	
p0 queue free %	100				100	87	
cM capacity (veh/h)	461				183	797	
Direction, Lane #	EB 1	EB 2	EB 3	WB 1	WB 2	WB 3	SB 1
Volume Total	433	433	433	798	798	435	104
Volume Left	0	0	0	0	0	0	0
Volume Right	0	0	0	0	0	36	104
cSH	1700	1700	1700	1700	1700	1700	797
Volume to Capacity	0.25	0.25	0.25	0.47	0.47	0.26	0.13
Queue Length 95th (m)	0.0	0.0	0.0	0.0	0.0	0.0	3.4
Control Delay (s)	0.0	0.0	0.0	0.0	0.0	0.0	10.2
Lane LOS							B
Approach Delay (s)	0.0			0.0			10.2
Approach LOS							B
Intersection Summary							
Average Delay			0.3				
Intersection Capacity Utilization			55.0%		ICU Level of Service		A
Analysis Period (min)			15				

# HCM Unsignalized Intersection Capacity Analysis

## 5: Croydon Ave & Bond St

Future Background (2024)  
PM Peak Hour











Movement	EBL	EBR	NBL	NBT	SBT	SBR
Lane Configurations						
Traffic Volume (veh/h)	2	13	12	218	256	13
Future Volume (Veh/h)	2	13	12	218	256	13
Sign Control	Stop			Free	Free	
Grade	0%			0%	0%	
Peak Hour Factor	1.00	1.00	1.00	1.00	1.00	1.00
Hourly flow rate (vph)	2	13	12	218	256	13
<b>Pedestrians</b>						
Lane Width (m)						
Walking Speed (m/s)						
Percent Blockage						
Right turn flare (veh)						
Median type				None	None	
Median storage veh						
Upstream signal (m)				78	181	
pX, platoon unblocked						
vC, conflicting volume	504	262	269			
vC1, stage 1 conf vol						
vC2, stage 2 conf vol						
vCu, unblocked vol	504	262	269			
tC, single (s)	6.4	6.2	4.1			
tC, 2 stage (s)						
tF (s)	3.5	3.3	2.2			
p0 queue free %	100	98	99			
cM capacity (veh/h)	526	781	1306			
<b>Direction, Lane #</b>	<b>EB 1</b>	<b>NB 1</b>	<b>SB 1</b>			
Volume Total	15	230	269			
Volume Left	2	12	0			
Volume Right	13	0	13			
cSH	734	1306	1700			
Volume to Capacity	0.02	0.01	0.16			
Queue Length 95th (m)	0.5	0.2	0.0			
Control Delay (s)	10.0	0.5	0.0			
Lane LOS	B	A				
Approach Delay (s)	10.0	0.5	0.0			
Approach LOS	B					
<b>Intersection Summary</b>						
Average Delay			0.5			
Intersection Capacity Utilization			32.5%	ICU Level of Service	A	
Analysis Period (min)			15			



HCM Unsignalized Intersection Capacity Analysis  
6: Forest St & Bond St

Future Background (2024)  
PM Peak Hour

						
Movement	WBL	WBR	NBT	NBR	SBL	SBT
Lane Configurations						
Traffic Volume (veh/h)	2	9	36	2	27	103
Future Volume (Veh/h)	2	9	36	2	27	103
Sign Control	Stop		Free		Free	
Grade	0%		0%		0%	
Peak Hour Factor	1.00	1.00	1.00	1.00	1.00	1.00
Hourly flow rate (vph)	2	9	36	2	27	103
Pedestrians						
Lane Width (m)						
Walking Speed (m/s)						
Percent Blockage						
Right turn flare (veh)						
Median type	None			None		
Median storage veh						
Upstream signal (m)						
pX, platoon unblocked						
vC, conflicting volume	194	37			38	
vC1, stage 1 conf vol						
vC2, stage 2 conf vol						
vCu, unblocked vol	194	37			38	
tC, single (s)	6.4	6.2			4.1	
tC, 2 stage (s)						
tF (s)	3.5	3.3			2.2	
p0 queue free %	100	99			98	
cM capacity (veh/h)	786	1041			1585	
Direction, Lane #	WB 1	NB 1	SB 1			
Volume Total	11	38	130			
Volume Left	2	0	27			
Volume Right	9	2	0			
cSH	983	1700	1585			
Volume to Capacity	0.01	0.02	0.02			
Queue Length 95th (m)	0.3	0.0	0.4			
Control Delay (s)	8.7	0.0	1.6			
Lane LOS	A		A			
Approach Delay (s)	8.7	0.0	1.6			
Approach LOS	A					
Intersection Summary						
Average Delay			1.7			
Intersection Capacity Utilization		24.0%		ICU Level of Service		A
Analysis Period (min)			15			

HCM Unsignalized Intersection Capacity Analysis  
7: Forest St & Richmond Rd

Future Background (2024)  
PM Peak Hour

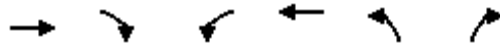

Movement	EBT	EBR	WBL	WBT	NBL	NBR
Lane Configurations	→			←	←	←
Traffic Volume (veh/h)	599	12	49	940	12	29
Future Volume (Veh/h)	599	12	49	940	12	29
Sign Control	Free			Free	Stop	
Grade	0%			0%	0%	
Peak Hour Factor	1.00	1.00	1.00	1.00	1.00	1.00
Hourly flow rate (vph)	599	12	49	940	12	29
<b>Pedestrians</b>						
Lane Width (m)						
Walking Speed (m/s)						
Percent Blockage						
Right turn flare (veh)						
Median type	None			None		
Median storage (veh)						
Upstream signal (m)	279			154		
pX, platoon unblocked				0.92	0.61	0.92
vC, conflicting volume				611	1643	605
vC1, stage 1 conf vol						
vC2, stage 2 conf vol						
vCu, unblocked vol				533	1438	527
tC, single (s)				4.1	6.4	6.2
tC, 2 stage (s)						
tF (s)				2.2	3.5	3.3
p0 queue free %				95	86	94
cM capacity (veh/h)				961	86	511
<b>Direction, Lane #</b>	<b>EB 1</b>	<b>WB 1</b>	<b>NB 1</b>			
Volume Total	611	989	41			
Volume Left	0	49	12			
Volume Right	12	0	29			
cSH	1700	961	209			
Volume to Capacity	0.36	0.05	0.20			
Queue Length 95th (m)	0.0	1.2	5.4			
Control Delay (s)	0.0	1.4	26.3			
Lane LOS		A	D			
Approach Delay (s)	0.0	1.4	26.3			
Approach LOS			D			
<b>Intersection Summary</b>						
Average Delay				1.5		
Intersection Capacity Utilization				102.5%	ICU Level of Service	G
Analysis Period (min)				15		





















HCM Signalized Intersection Capacity Analysis  
 9: Richmond Rd & Carling Ave

Future Background (2024)  
 PM Peak Hour

Movement	EBL	EBT	EBR	WBL	WBT	WBR	NBL	NBT	NBR	SBL	SBT	SBR	
Lane Configurations													
Traffic Volume (vph)	252	748	3	14	1899	2	0	499	509	0	779	354	
Future Volume (vph)	252	748	3	14	1899	2	0	499	509	0	779	354	
Ideal Flow (vphpl)	1800	1800	1800	1800	1800	1800	1800	1800	1800	1800	1800	1800	
Total Lost time (s)	6.0	5.8		6.0	5.8			7.0	4.0		7.0	4.0	
Lane Util. Factor	1.00	0.95		1.00	0.91			0.95	1.00		0.95	1.00	
Frpb, ped/bikes	1.00	1.00		1.00	1.00			1.00	0.99		1.00	0.99	
Flpb, ped/bikes	1.00	1.00		1.00	1.00			1.00	1.00		1.00	1.00	
Frt	1.00	1.00		1.00	1.00			1.00	0.85		1.00	0.85	
Flt Protected	0.95	1.00		0.95	1.00			1.00	1.00		1.00	1.00	
Satd. Flow (prot)	1695	3388		988	4919			3390	1496		3357	1497	
Flt Permitted	0.95	1.00		0.95	1.00			1.00	1.00		1.00	1.00	
Satd. Flow (perm)	1695	3388		988	4919			3390	1496		3357	1497	
Peak-hour factor, PHF	1.00	1.00	1.00	1.00	1.00	1.00	1.00	1.00	1.00	1.00	1.00	1.00	
Adj. Flow (vph)	252	748	3	14	1899	2	0	499	509	0	779	354	
RTOR Reduction (vph)	0	0	0	0	0	0	0	0	0	0	0	0	
Lane Group Flow (vph)	252	751	0	14	1901	0	0	499	509	0	779	354	
Confl. Peds. (#/hr)	7		2	2		7	2		3	3		2	
Confl. Bikes (#/hr)	7		2	2		7	2		3	3		2	
Heavy Vehicles (%)	2%	2%	0%	75%	1%	0%	2%	2%	2%	2%	3%	2%	
Turn Type	Prot	NA		Prot	NA			NA	Free		NA	Free	
Protected Phases	5	2		19	6			8			4		
Permitted Phases									Free			Free	
Actuated Green, G (s)	22.3	63.6		6.0	53.3			35.6	130.0		35.6	130.0	
Effective Green, g (s)	22.3	63.6		6.0	53.3			35.6	130.0		35.6	130.0	
Actuated g/C Ratio	0.17	0.49		0.05	0.41			0.27	1.00		0.27	1.00	
Clearance Time (s)	6.0	5.8			5.8			7.0			7.0		
Vehicle Extension (s)	3.0	3.0			3.0			3.0			3.0		
Lane Grp Cap (vph)	290	1657		45	2016			928	1496		919	1497	
v/s Ratio Prot	c0.15	0.22		0.01	c0.39			0.15			c0.23		
v/s Ratio Perm									0.34			0.24	
v/c Ratio	0.87	0.45		0.31	0.94			0.54	0.34		0.85	0.24	
Uniform Delay, d1	52.4	21.8		60.0	36.9			40.2	0.0		44.6	0.0	
Progression Factor	1.00	1.00		0.91	0.61			1.00	1.00		1.00	1.00	
Incremental Delay, d2	23.0	0.9		3.3	9.1			0.6	0.6		7.3	0.4	
Delay (s)	75.4	22.7		58.0	31.7			40.8	0.6		52.0	0.4	
Level of Service	E	C		E	C			D	A		D	A	
Approach Delay (s)		35.9			31.9			20.5			35.8		
Approach LOS		D			C			C			D		
<b>Intersection Summary</b>													
HCM 2000 Control Delay			31.3									HCM 2000 Level of Service	C
HCM 2000 Volume to Capacity ratio			0.95										
Actuated Cycle Length (s)			130.0									Sum of lost time (s)	24.8
Intersection Capacity Utilization			92.5%									ICU Level of Service	F
Analysis Period (min)			15										
c Critical Lane Group													



















HCM Signalized Intersection Capacity Analysis  
10: Poulin St & Richmond Rd

Future Background (2024)  
PM Peak Hour

													
Movement	EBL	EBT	EBR	WBL	WBT	WBR	NBL	NBT	NBR	SBL	SBT	SBR	
Lane Configurations													
Traffic Volume (vph)	226	476	3	0	956	46	42	60	14	73	2	135	
Future Volume (vph)	226	476	3	0	956	46	42	60	14	73	2	135	
Ideal Flow (vphpl)	1800	1800	1800	1800	1800	1800	1800	1800	1800	1800	1800	1800	
Total Lost time (s)	6.3	6.3			6.3			6.2			6.2	6.2	
Lane Util. Factor	1.00	1.00			0.95			1.00			1.00	1.00	
Frbp, ped/bikes	1.00	1.00			1.00			0.99			1.00	0.98	
Flpb, ped/bikes	1.00	1.00			1.00			1.00			0.99	1.00	
Frt	1.00	1.00			0.99			0.98			1.00	0.85	
Flt Protected	0.95	1.00			1.00			0.98			0.95	1.00	
Satd. Flow (prot)	1729	1818			3429			1748			1722	1520	
Flt Permitted	0.18	1.00			1.00			0.85			0.66	1.00	
Satd. Flow (perm)	334	1818			3429			1511			1195	1520	
Peak-hour factor, PHF	1.00	1.00	1.00	1.00	1.00	1.00	1.00	1.00	1.00	1.00	1.00	1.00	
Adj. Flow (vph)	226	476	3	0	956	46	42	60	14	73	2	135	
RTOR Reduction (vph)	0	0	0	0	3	0	0	7	0	0	0	116	
Lane Group Flow (vph)	226	479	0	0	999	0	0	109	0	0	75	19	
Confl. Peds. (#/hr)	6		16	16		6	2		6	6		2	
Confl. Bikes (#/hr)	6		16	16		6	2		6	6		2	
Heavy Vehicles (%)	0%	0%	0%	2%	0%	0%	0%	0%	0%	0%	0%	0%	
Turn Type	pm+pt	NA			NA		Perm	NA		Perm	NA	Perm	
Protected Phases	5	2			6			8			4		
Permitted Phases	2						8			4		4	
Actuated Green, G (s)	65.1	65.1			45.3			12.4			12.4	12.4	
Effective Green, g (s)	65.1	65.1			45.3			12.4			12.4	12.4	
Actuated g/C Ratio	0.72	0.72			0.50			0.14			0.14	0.14	
Clearance Time (s)	6.3	6.3			6.3			6.2			6.2	6.2	
Vehicle Extension (s)	3.0	3.0			3.0			3.0			3.0	3.0	
Lane Grp Cap (vph)	450	1315			1725			208			164	209	
v/s Ratio Prot	c0.08	0.26			c0.29								
v/s Ratio Perm	0.29							c0.07			0.06	0.01	
v/c Ratio	0.50	0.36			0.58			0.52			0.46	0.09	
Uniform Delay, d1	7.3	4.7			15.7			36.1			35.7	33.9	
Progression Factor	1.00	1.00			1.00			1.00			1.00	1.00	
Incremental Delay, d2	0.9	0.8			1.4			2.4			2.0	0.2	
Delay (s)	8.2	5.5			17.1			38.4			37.7	34.1	
Level of Service	A	A			B			D			D	C	
Approach Delay (s)		6.3			17.1			38.4			35.4		
Approach LOS		A			B			D			D		
<b>Intersection Summary</b>													
HCM 2000 Control Delay			16.5									HCM 2000 Level of Service	B
HCM 2000 Volume to Capacity ratio			0.56										
Actuated Cycle Length (s)			90.0									Sum of lost time (s)	18.8
Intersection Capacity Utilization			73.4%									ICU Level of Service	D
Analysis Period (min)			15										
c Critical Lane Group													

HCM Signalized Intersection Capacity Analysis  
1: Croydon Ave & Richmond Rd

Future Background (2029)  
AM Peak Hour

												
Movement	EBL	EBT	EBR	WBL	WBT	WBR	NBL	NBT	NBR	SBL	SBT	SBR
Lane Configurations												
Traffic Volume (vph)	25	628	76	19	419	19	42	32	89	31	80	42
Future Volume (vph)	25	628	76	19	419	19	42	32	89	31	80	42
Ideal Flow (vphpl)	1800	1800	1800	1800	1800	1800	1800	1800	1800	1800	1800	1800
Lane Width	3.4	3.4	3.7	3.0	3.4	3.7	3.5	3.5	3.7	3.7	4.8	3.7
Total Lost time (s)	6.4	6.4		6.4	6.4		6.1	6.1			6.1	
Lane Util. Factor	1.00	1.00		1.00	1.00		1.00	1.00			1.00	
Frpb, ped/bikes	1.00	1.00		1.00	1.00		1.00	0.94			0.98	
Flpb, ped/bikes	0.98	1.00		0.99	1.00		0.97	1.00			0.99	
Fr <sub>t</sub>	1.00	0.98		1.00	0.99		1.00	0.89			0.96	
Fl <sub>t</sub> Protected	0.95	1.00		0.95	1.00		0.95	1.00			0.99	
Satd. Flow (prot)	1561	1572		1583	1584		1389	1391			1849	
Fl <sub>t</sub> Permitted	0.50	1.00		0.33	1.00		0.64	1.00			0.90	
Satd. Flow (perm)	824	1572		556	1584		933	1391			1676	
Peak-hour factor, PHF	1.00	1.00	1.00	1.00	1.00	1.00	1.00	1.00	1.00	1.00	1.00	1.00
Adj. Flow (vph)	25	628	76	19	419	19	42	32	89	31	80	42
RTOR Reduction (vph)	0	4	0	0	1	0	0	77	0	0	26	0
Lane Group Flow (vph)	25	700	0	19	437	0	42	44	0	0	127	0
Confl. Peds. (#/hr)	21		15	15		21	29		41	41		29
Heavy Vehicles (%)	5%	4%	15%	0%	6%	0%	18%	20%	3%	4%	0%	6%
Bus Blockages (#/hr)	0	10	0	0	10	0	0	0	0	0	0	0
Turn Type	Perm	NA		Perm	NA		Perm	NA		Perm	NA	
Protected Phases		2			6			8			4	
Permitted Phases	2			6			8			4		
Actuated Green, G (s)	48.0	48.0		48.0	48.0		9.5	9.5			9.5	
Effective Green, g (s)	48.0	48.0		48.0	48.0		9.5	9.5			9.5	
Actuated g/C Ratio	0.69	0.69		0.69	0.69		0.14	0.14			0.14	
Clearance Time (s)	6.4	6.4		6.4	6.4		6.1	6.1			6.1	
Vehicle Extension (s)	3.0	3.0		3.0	3.0		3.0	3.0			3.0	
Lane Grp Cap (vph)	565	1077		381	1086		126	188			227	
v/s Ratio Prot		c0.45			0.28			0.03				
v/s Ratio Perm	0.03			0.03			0.05				c0.08	
v/c Ratio	0.04	0.65		0.05	0.40		0.33	0.23			0.56	
Uniform Delay, d <sub>1</sub>	3.6	6.2		3.6	4.8		27.4	27.0			28.3	
Progression Factor	1.00	1.00		1.00	1.00		1.00	1.00			1.00	
Incremental Delay, d <sub>2</sub>	0.1	3.0		0.2	1.1		1.6	0.6			3.0	
Delay (s)	3.7	9.3		3.8	5.9		28.9	27.6			31.3	
Level of Service	A	A		A	A		C	C			C	
Approach Delay (s)		9.1			5.8			28.0			31.3	
Approach LOS		A			A			C			C	
<b>Intersection Summary</b>												
HCM 2000 Control Delay			12.4				HCM 2000 Level of Service				B	
HCM 2000 Volume to Capacity ratio			0.63									
Actuated Cycle Length (s)			70.0				Sum of lost time (s)			12.5		
Intersection Capacity Utilization			87.6%				ICU Level of Service			E		
Analysis Period (min)			15									

c Critical Lane Group

# HCM Signalized Intersection Capacity Analysis

## 2: Alpine Ave/1460 Richmond & Carling Ave

Future Background (2029)  
AM Peak Hour



Movement	EBL	EBT	EBR	WBL	WBT	WBR	NBL	NBT	NBR	SBL	SBT	SBR
Lane Configurations	↗	↑↑↑		↗	↑↑↑			↕			↕	
Traffic Volume (vph)	36	3036	7	37	1045	83	27	9	107	41	9	52
Future Volume (vph)	36	3036	7	37	1045	83	27	9	107	41	9	52
Ideal Flow (vphpl)	1800	1800	1800	1800	1800	1800	1800	1800	1800	1800	1800	1800
Lane Width	3.0	3.6	3.7	3.0	3.7	3.7	3.7	4.8	3.7	3.7	3.6	3.7
Total Lost time (s)	5.9	5.9		5.9	5.9			6.7			6.7	
Lane Util. Factor	1.00	0.91		1.00	0.91			1.00			1.00	
Frbp, ped/bikes	1.00	1.00		1.00	0.99			0.96			0.99	
Flpb, ped/bikes	0.98	1.00		1.00	1.00			1.00			0.99	
Frt	1.00	1.00		1.00	0.99			0.90			0.93	
Flt Protected	0.95	1.00		0.95	1.00			0.99			0.98	
Satd. Flow (prot)	1508	4764		1596	4643			1674			1570	
Flt Permitted	0.24	1.00		0.04	1.00			0.89			0.62	
Satd. Flow (perm)	381	4764		68	4643			1504			994	
Peak-hour factor, PHF	1.00	1.00	1.00	1.00	1.00	1.00	1.00	1.00	1.00	1.00	1.00	1.00
Adj. Flow (vph)	36	3036	7	37	1045	83	27	9	107	41	9	52
RTOR Reduction (vph)	0	0	0	0	4	0	0	67	0	0	36	0
Lane Group Flow (vph)	36	3043	0	37	1124	0	0	76	0	0	66	0
Confl. Peds. (#/hr)	36		27	27		36	11		27	27		11
Heavy Vehicles (%)	4%	2%	0%	0%	4%	3%	10%	0%	3%	3%	0%	2%
Bus Blockages (#/hr)	0	8	0	0	8	0	0	0	0	0	0	0
Turn Type	Perm	NA		pm+pt	NA		Perm	NA		Perm	NA	
Protected Phases		2		1	6			8			4	
Permitted Phases	2			6			8			4		
Actuated Green, G (s)	93.6	93.6		104.5	104.5			12.9			12.9	
Effective Green, g (s)	93.6	93.6		104.5	104.5			12.9			12.9	
Actuated g/C Ratio	0.72	0.72		0.80	0.80			0.10			0.10	
Clearance Time (s)	5.9	5.9		5.9	5.9			6.7			6.7	
Vehicle Extension (s)	3.0	3.0		3.0	3.0			3.0			3.0	
Lane Grp Cap (vph)	274	3430		113	3732			149			98	
v/s Ratio Prot		c0.64		0.01	c0.24							
v/s Ratio Perm	0.09			0.25				0.05			c0.07	
v/c Ratio	0.13	0.89		0.33	0.30			0.51			0.67	
Uniform Delay, d1	5.6	14.1		19.9	3.3			55.6			56.5	
Progression Factor	0.56	0.48		3.23	0.83			1.00			1.00	
Incremental Delay, d2	0.5	2.2		1.6	0.2			3.0			16.7	
Delay (s)	3.7	8.9		65.8	2.9			58.5			73.2	
Level of Service	A	A		E	A			E			E	
Approach Delay (s)		8.9			4.9			58.5			73.2	
Approach LOS		A			A			E			E	

### Intersection Summary

HCM 2000 Control Delay	10.9	HCM 2000 Level of Service	B
HCM 2000 Volume to Capacity ratio	0.84		
Actuated Cycle Length (s)	130.0	Sum of lost time (s)	18.5
Intersection Capacity Utilization	90.5%	ICU Level of Service	E
Analysis Period (min)	15		

c Critical Lane Group

HCM Signalized Intersection Capacity Analysis  
3: Carling Ave & Croydon Ave

Future Background (2029)  
AM Peak Hour



Movement	EBL	EBT	WBT	WBR	SBL	SBR
Lane Configurations	↖	↑↑↑	↑↑↑		↘↘	
Traffic Volume (vph)	117	2487	1027	108	191	31
Future Volume (vph)	117	2487	1027	108	191	31
Ideal Flow (vphpl)	1800	1800	1800	1800	1800	1800
Lane Width	2.8	3.6	3.7	3.7	3.7	3.3
Total Lost time (s)	5.9	5.9	5.9		6.3	
Lane Util. Factor	1.00	0.91	0.91		0.97	
Frpb, ped/bikes	1.00	1.00	0.99		1.00	
Flpb, ped/bikes	1.00	1.00	1.00		1.00	
Frt	1.00	1.00	0.99		0.98	
Flt Protected	0.95	1.00	1.00		0.96	
Satd. Flow (prot)	1526	4696	4589		3111	
Flt Permitted	0.21	1.00	1.00		0.96	
Satd. Flow (perm)	335	4696	4589		3111	
Peak-hour factor, PHF	1.00	1.00	1.00	1.00	1.00	1.00
Adj. Flow (vph)	117	2487	1027	108	191	31
RTOR Reduction (vph)	0	0	7	0	12	0
Lane Group Flow (vph)	117	2487	1128	0	210	0
Confl. Peds. (#/hr)	16			16	2	19
Heavy Vehicles (%)	2%	2%	3%	7%	7%	0%
Bus Blockages (#/hr)	0	19	19	0	0	0
Turn Type	pm+pt	NA	NA		Prot	
Protected Phases	5	2	6		7	
Permitted Phases	2					
Actuated Green, G (s)	103.7	103.7	90.0		14.1	
Effective Green, g (s)	103.7	103.7	90.0		14.1	
Actuated g/C Ratio	0.80	0.80	0.69		0.11	
Clearance Time (s)	5.9	5.9	5.9		6.3	
Vehicle Extension (s)	3.0	3.0	3.0		3.0	
Lane Grp Cap (vph)	338	3745	3177		337	
v/s Ratio Prot	0.02	c0.53	0.25		c0.07	
v/s Ratio Perm	0.26					
v/c Ratio	0.35	0.66	0.36		0.62	
Uniform Delay, d1	3.7	5.7	8.2		55.4	
Progression Factor	0.56	0.31	1.00		1.00	
Incremental Delay, d2	0.3	0.5	0.3		3.5	
Delay (s)	2.4	2.2	8.5		58.9	
Level of Service	A	A	A		E	
Approach Delay (s)		2.2	8.5		58.9	
Approach LOS		A	A		E	

Intersection Summary				
HCM 2000 Control Delay		7.2	HCM 2000 Level of Service	A
HCM 2000 Volume to Capacity ratio		0.69		
Actuated Cycle Length (s)		130.0	Sum of lost time (s)	18.1
Intersection Capacity Utilization		77.4%	ICU Level of Service	D
Analysis Period (min)		15		

c Critical Lane Group

HCM Unsignalized Intersection Capacity Analysis  
4: Carling Ave & Forest St

Future Background (2029)  
AM Peak Hour

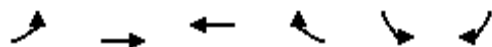

Movement	EBL	EBT	WBT	WBR	SBL	SBR	
Lane Configurations		↑↑↑	↑↑↑			↑	
Traffic Volume (veh/h)	0	3192	1106	27	0	59	
Future Volume (Veh/h)	0	3192	1106	27	0	59	
Sign Control		Free	Free		Stop		
Grade		0%	0%		0%		
Peak Hour Factor	1.00	1.00	1.00	1.00	1.00	1.00	
Hourly flow rate (vph)	0	3192	1106	27	0	59	
Pedestrians							
Lane Width (m)							
Walking Speed (m/s)							
Percent Blockage							
Right turn flare (veh)							
Median type		None	None				
Median storage (veh)							
Upstream signal (m)		55	141				
pX, platoon unblocked	0.92				0.33	0.92	
vC, conflicting volume	1133				2184	382	
vC1, stage 1 conf vol							
vC2, stage 2 conf vol							
vCu, unblocked vol	836				0	19	
tC, single (s)	4.1				6.8	6.9	
tC, 2 stage (s)							
tF (s)	2.2				3.5	3.3	
p0 queue free %	100				100	94	
cM capacity (veh/h)	741				341	975	
Direction, Lane #	EB 1	EB 2	EB 3	WB 1	WB 2	WB 3	SB 1
Volume Total	1064	1064	1064	442	442	248	59
Volume Left	0	0	0	0	0	0	0
Volume Right	0	0	0	0	0	27	59
cSH	1700	1700	1700	1700	1700	1700	975
Volume to Capacity	0.63	0.63	0.63	0.26	0.26	0.15	0.06
Queue Length 95th (m)	0.0	0.0	0.0	0.0	0.0	0.0	1.5
Control Delay (s)	0.0	0.0	0.0	0.0	0.0	0.0	8.9
Lane LOS							A
Approach Delay (s)	0.0			0.0			8.9
Approach LOS							A
Intersection Summary							
Average Delay			0.1				
Intersection Capacity Utilization			68.4%		ICU Level of Service		C
Analysis Period (min)			15				



HCM Unsignalized Intersection Capacity Analysis  
5: Croydon Ave & Bond St









Future Background (2029)  
AM Peak Hour



Movement	EBL	EBR	NBL	NBT	SBT	SBR
Lane Configurations						
Traffic Volume (veh/h)	2	11	11	213	210	11
Future Volume (Veh/h)	2	11	11	213	210	11
Sign Control	Stop			Free	Free	
Grade	0%			0%	0%	
Peak Hour Factor	1.00	1.00	1.00	1.00	1.00	1.00
Hourly flow rate (vph)	2	11	11	213	210	11
<b>Pedestrians</b>						
Lane Width (m)						
Walking Speed (m/s)						
Percent Blockage						
Right turn flare (veh)						
Median type				None	None	
Median storage (veh)						
Upstream signal (m)				78	181	
pX, platoon unblocked						
vC, conflicting volume	450	216	221			
vC1, stage 1 conf vol						
vC2, stage 2 conf vol						
vCu, unblocked vol	450	216	221			
tC, single (s)	6.4	6.2	4.1			
tC, 2 stage (s)						
tF (s)	3.5	3.3	2.2			
p0 queue free %	100	99	99			
cM capacity (veh/h)	566	829	1360			
<b>Direction, Lane #</b>	<b>EB 1</b>	<b>NB 1</b>	<b>SB 1</b>			
Volume Total	13	224	221			
Volume Left	2	11	0			
Volume Right	11	0	11			
cSH	774	1360	1700			
Volume to Capacity	0.02	0.01	0.13			
Queue Length 95th (m)	0.4	0.2	0.0			
Control Delay (s)	9.7	0.4	0.0			
Lane LOS	A	A				
Approach Delay (s)	9.7	0.4	0.0			
Approach LOS	A					
<b>Intersection Summary</b>						
Average Delay				0.5		
Intersection Capacity Utilization				31.3%	ICU Level of Service	A
Analysis Period (min)				15		

HCM Unsignalized Intersection Capacity Analysis  
6: Forest St & Bond St

Future Background (2029)  
AM Peak Hour

						
Movement	WBL	WBR	NBT	NBR	SBL	SBT
Lane Configurations						
Traffic Volume (veh/h)	2	8	27	2	15	58
Future Volume (Veh/h)	2	8	27	2	15	58
Sign Control	Stop		Free		Free	
Grade	0%		0%		0%	
Peak Hour Factor	1.00	1.00	1.00	1.00	1.00	1.00
Hourly flow rate (vph)	2	8	27	2	15	58
<b>Pedestrians</b>						
Lane Width (m)						
Walking Speed (m/s)						
Percent Blockage						
Right turn flare (veh)						
Median type	None			None		
Median storage (veh)						
Upstream signal (m)						
pX, platoon unblocked						
vC, conflicting volume	116	28			29	
vC1, stage 1 conf vol						
vC2, stage 2 conf vol						
vCu, unblocked vol	116	28			29	
tC, single (s)	6.4	6.2			4.1	
tC, 2 stage (s)						
tF (s)	3.5	3.3			2.2	
p0 queue free %	100	99			99	
cM capacity (veh/h)	877	1053			1597	
<b>Direction, Lane #</b>	<b>WB 1</b>	<b>NB 1</b>	<b>SB 1</b>			
Volume Total	10	29	73			
Volume Left	2	0	15			
Volume Right	8	2	0			
cSH	1012	1700	1597			
Volume to Capacity	0.01	0.02	0.01			
Queue Length 95th (m)	0.2	0.0	0.2			
Control Delay (s)	8.6	0.0	1.6			
Lane LOS	A		A			
Approach Delay (s)	8.6	0.0	1.6			
Approach LOS	A					
<b>Intersection Summary</b>						
Average Delay			1.8			
Intersection Capacity Utilization			20.8%		ICU Level of Service	A
Analysis Period (min)			15			

HCM Unsignalized Intersection Capacity Analysis  
7: Forest St & Richmond Rd



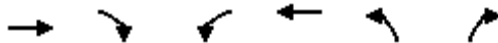

















Future Background (2029)  
AM Peak Hour



Movement	EBT	EBR	WBL	WBT	NBL	NBR
Lane Configurations	→			←	←	←
Traffic Volume (veh/h)	692	13	26	476	13	36
Future Volume (Veh/h)	692	13	26	476	13	36
Sign Control	Free			Free	Stop	
Grade	0%			0%	0%	
Peak Hour Factor	1.00	1.00	1.00	1.00	1.00	1.00
Hourly flow rate (vph)	692	13	26	476	13	36
<b>Pedestrians</b>						
Lane Width (m)						
Walking Speed (m/s)						
Percent Blockage						
Right turn flare (veh)						
Median type	None			None		
Median storage (veh)						
Upstream signal (m)	279			154		
pX, platoon unblocked				0.88	0.92	0.88
vC, conflicting volume				705	1226	698
vC1, stage 1 conf vol						
vC2, stage 2 conf vol						
vCu, unblocked vol				592	986	585
tC, single (s)				4.1	6.4	6.2
tC, 2 stage (s)						
tF (s)				2.2	3.5	3.3
p0 queue free %				97	95	92
cM capacity (veh/h)				870	248	451
<b>Direction, Lane #</b>	<b>EB 1</b>	<b>WB 1</b>	<b>NB 1</b>			
Volume Total	705	502	49			
Volume Left	0	26	13			
Volume Right	13	0	36			
cSH	1700	870	370			
Volume to Capacity	0.41	0.03	0.13			
Queue Length 95th (m)	0.0	0.7	3.4			
Control Delay (s)	0.0	0.8	16.2			
Lane LOS	A		C			
Approach Delay (s)	0.0	0.8	16.2			
Approach LOS	C					
<b>Intersection Summary</b>						
Average Delay	1.0					
Intersection Capacity Utilization	58.8%			ICU Level of Service	B	
Analysis Period (min)	15					

HCM Signalized Intersection Capacity Analysis  
 9: Richmond Rd & Carling Ave



















Future Background (2029)  
 AM Peak Hour

												
Movement	EBL	EBT	EBR	WBL	WBT	WBR	NBL	NBT	NBR	SBL	SBT	SBR
Lane Configurations												
Traffic Volume (vph)	180	1709	0	5	1105	0	0	599	1369	0	342	217
Future Volume (vph)	180	1709	0	5	1105	0	0	599	1369	0	342	217
Ideal Flow (vphpl)	1800	1800	1800	1800	1800	1800	1800	1800	1800	1800	1800	1800
Total Lost time (s)	6.0	5.8		6.0	5.8			7.0	4.0		7.0	4.0
Lane Util. Factor	1.00	0.95		1.00	0.91			0.95	1.00		0.95	1.00
Frbp, ped/bikes	1.00	1.00		1.00	1.00			1.00	0.99		1.00	0.98
Flpb, ped/bikes	1.00	1.00		1.00	1.00			1.00	1.00		1.00	1.00
Frt	1.00	1.00		1.00	1.00			1.00	0.85		1.00	0.85
Flt Protected	0.95	1.00		0.95	1.00			1.00	1.00		1.00	1.00
Satd. Flow (prot)	1679	3369		864	4772			3325	1495		3325	1479
Flt Permitted	0.95	1.00		0.95	1.00			1.00	1.00		1.00	1.00
Satd. Flow (perm)	1679	3369		864	4772			3325	1495		3325	1479
Peak-hour factor, PHF	1.00	1.00	1.00	1.00	1.00	1.00	1.00	1.00	1.00	1.00	1.00	1.00
Adj. Flow (vph)	180	1709	0	5	1105	0	0	599	1369	0	342	217
RTOR Reduction (vph)	0	0	0	0	0	0	0	0	0	0	0	0
Lane Group Flow (vph)	180	1709	0	5	1105	0	0	599	1369	0	342	217
Confl. Peds. (#/hr)	8		7	7		8	6		4	4		6
Confl. Bikes (#/hr)	8		7	7		8	6		4	4		6
Heavy Vehicles (%)	3%	1%	0%	100%	3%	0%	0%	4%	2%	0%	4%	3%
Bus Blockages (#/hr)	0	8	0	0	8	0	0	0	0	0	0	0
Turn Type	Prot	NA		Prot	NA			NA	Free		NA	Free
Protected Phases	5	2		19	6			8			4	
Permitted Phases									Free			Free
Actuated Green, G (s)	18.5	63.2		3.0	53.7			39.0	130.0		39.0	130.0
Effective Green, g (s)	18.5	63.2		3.0	53.7			39.0	130.0		39.0	130.0
Actuated g/C Ratio	0.14	0.49		0.02	0.41			0.30	1.00		0.30	1.00
Clearance Time (s)	6.0	5.8			5.8			7.0			7.0	
Vehicle Extension (s)	3.0	3.0			3.0			3.0			3.0	
Lane Grp Cap (vph)	238	1637		19	1971			997	1495		997	1479
v/s Ratio Prot	0.11	c0.51		0.01	0.23			0.18			0.10	
v/s Ratio Perm									c0.92			0.15
v/c Ratio	0.76	1.04		0.26	0.56			0.60	0.92		0.34	0.15
Uniform Delay, d1	53.6	33.4		62.4	29.1			38.9	0.0		35.5	0.0
Progression Factor	1.00	1.00		1.06	0.79			1.00	1.00		0.92	1.00
Incremental Delay, d2	12.8	34.7		7.1	1.1			2.7	10.3		0.2	0.2
Delay (s)	66.4	68.1		73.1	24.0			41.5	10.3		32.8	0.2
Level of Service	E	E		E	C			D	B		C	A
Approach Delay (s)		67.9			24.2			19.8			20.1	
Approach LOS		E			C			B			C	
<b>Intersection Summary</b>												
HCM 2000 Control Delay			37.2									D
HCM 2000 Volume to Capacity ratio			1.16									
Actuated Cycle Length (s)			130.0									24.8
Intersection Capacity Utilization			106.4%									G
Analysis Period (min)			15									

c Critical Lane Group



















HCM Signalized Intersection Capacity Analysis  
10: Poulin St & Richmond Rd

Future Background (2029)  
AM Peak Hour

													
Movement	EBL	EBT	EBR	WBL	WBT	WBR	NBL	NBT	NBR	SBL	SBT	SBR	
Lane Configurations													
Traffic Volume (vph)	147	630	3	0	458	33	3	22	4	83	0	99	
Future Volume (vph)	147	630	3	0	458	33	3	22	4	83	0	99	
Ideal Flow (vphpl)	1800	1800	1800	1800	1800	1800	1800	1800	1800	1800	1800	1800	
Total Lost time (s)	6.3	6.3			6.3			6.2			6.2	6.2	
Lane Util. Factor	1.00	1.00			0.95			1.00			1.00	1.00	
Frbp, ped/bikes	1.00	1.00			1.00			0.99			1.00	0.97	
Flpb, ped/bikes	0.99	1.00			1.00			1.00			0.99	1.00	
Frt	1.00	1.00			0.99			0.98			1.00	0.85	
Flt Protected	0.95	1.00			1.00			0.99			0.95	1.00	
Satd. Flow (prot)	1624	1732			3286			1686			1452	1422	
Flt Permitted	0.47	1.00			1.00			0.97			0.74	1.00	
Satd. Flow (perm)	808	1732			3286			1645			1128	1422	
Peak-hour factor, PHF	1.00	1.00	1.00	1.00	1.00	1.00	1.00	1.00	1.00	1.00	1.00	1.00	
Adj. Flow (vph)	147	630	3	0	458	33	3	22	4	83	0	99	
RTOR Reduction (vph)	0	0	0	0	3	0	0	4	0	0	0	87	
Lane Group Flow (vph)	147	633	0	0	488	0	0	25	0	0	83	12	
Confl. Peds. (#/hr)	10		5	5		10	7		4	4		7	
Confl. Bikes (#/hr)	10		5	5		10	7		4	4		7	
Heavy Vehicles (%)	5%	5%	0%	0%	3%	15%	0%	0%	34%	18%	0%	5%	
Turn Type	Perm	NA			NA		Perm	NA		Perm	NA	Perm	
Protected Phases		2			6			8			4		
Permitted Phases	2						8			4		4	
Actuated Green, G (s)	102.2	102.2			102.2			15.3			15.3	15.3	
Effective Green, g (s)	102.2	102.2			102.2			15.3			15.3	15.3	
Actuated g/C Ratio	0.79	0.79			0.79			0.12			0.12	0.12	
Clearance Time (s)	6.3	6.3			6.3			6.2			6.2	6.2	
Vehicle Extension (s)	3.0	3.0			3.0			3.0			3.0	3.0	
Lane Grp Cap (vph)	635	1361			2583			193			132	167	
v/s Ratio Prot		c0.37			0.15								
v/s Ratio Perm	0.18							0.02			c0.07	0.01	
v/c Ratio	0.23	0.47			0.19			0.13			0.63	0.07	
Uniform Delay, d1	3.6	4.7			3.5			51.4			54.6	51.0	
Progression Factor	0.03	0.86			1.00			0.94			1.00	1.00	
Incremental Delay, d2	0.7	0.9			0.2			0.3			9.0	0.2	
Delay (s)	0.8	4.9			3.7			48.7			63.7	51.2	
Level of Service	A	A			A			D			E	D	
Approach Delay (s)		4.2			3.7			48.7			56.9		
Approach LOS		A			A			D			E		
<b>Intersection Summary</b>													
HCM 2000 Control Delay			11.3									HCM 2000 Level of Service	B
HCM 2000 Volume to Capacity ratio			0.49										
Actuated Cycle Length (s)			130.0									Sum of lost time (s)	12.5
Intersection Capacity Utilization			59.4%									ICU Level of Service	B
Analysis Period (min)			15										
c Critical Lane Group													

HCM Signalized Intersection Capacity Analysis  
1: Croydon Ave & Richmond Rd

Future Background (2029)  
PM Peak Hour

												
Movement	EBL	EBT	EBR	WBL	WBT	WBR	NBL	NBT	NBR	SBL	SBT	SBR
Lane Configurations												
Traffic Volume (vph)	29	527	133	66	907	20	160	109	41	16	69	22
Future Volume (vph)	29	527	133	66	907	20	160	109	41	16	69	22
Ideal Flow (vphpl)	1800	1800	1800	1800	1800	1800	1800	1800	1800	1800	1800	1800
Lane Width	3.4	3.4	3.7	3.0	3.4	3.7	3.5	3.5	3.7	3.7	4.8	3.7
Total Lost time (s)	6.4	6.4		6.4	6.4		6.1	6.1			6.1	
Lane Util. Factor	1.00	1.00		1.00	1.00		1.00	1.00			1.00	
Frbp, ped/bikes	1.00	0.99		1.00	1.00		1.00	0.97			0.99	
Flpb, ped/bikes	1.00	1.00		0.98	1.00		0.96	1.00			0.99	
Frt	1.00	0.97		1.00	1.00		1.00	0.96			0.97	
Flt Protected	0.95	1.00		0.95	1.00		0.95	1.00			0.99	
Satd. Flow (prot)	1672	1565		1541	1649		1559	1634			1917	
Flt Permitted	0.18	1.00		0.34	1.00		0.73	1.00			0.94	
Satd. Flow (perm)	317	1565		545	1649		1200	1634			1812	
Peak-hour factor, PHF	1.00	1.00	1.00	1.00	1.00	1.00	1.00	1.00	1.00	1.00	1.00	1.00
Adj. Flow (vph)	29	527	133	66	907	20	160	109	41	16	69	22
RTOR Reduction (vph)	0	8	0	0	1	0	0	18	0	0	13	0
Lane Group Flow (vph)	29	652	0	66	926	0	160	132	0	0	94	0
Confl. Peds. (#/hr)	30		24	24		30	29		59	59		29
Heavy Vehicles (%)	0%	2%	8%	2%	2%	0%	4%	0%	4%	0%	0%	0%
Bus Blockages (#/hr)	0	10	0	0	10	0	0	0	0	0	0	0
Turn Type	Perm	NA		Perm	NA		Perm	NA		Perm	NA	
Protected Phases		2			6			8			4	
Permitted Phases	2			6			8			4		
Actuated Green, G (s)	55.8	55.8		55.8	55.8		16.7	16.7			16.7	
Effective Green, g (s)	55.8	55.8		55.8	55.8		16.7	16.7			16.7	
Actuated g/C Ratio	0.66	0.66		0.66	0.66		0.20	0.20			0.20	
Clearance Time (s)	6.4	6.4		6.4	6.4		6.1	6.1			6.1	
Vehicle Extension (s)	3.0	3.0		3.0	3.0		3.0	3.0			3.0	
Lane Grp Cap (vph)	208	1027		357	1082		235	321			356	
v/s Ratio Prot		0.42			c0.56			0.08				
v/s Ratio Perm	0.09			0.12			c0.13				0.05	
v/c Ratio	0.14	0.63		0.18	0.86		0.68	0.41			0.26	
Uniform Delay, d1	5.5	8.6		5.7	11.5		31.7	29.8			28.9	
Progression Factor	1.00	1.00		1.00	1.00		1.00	1.00			1.00	
Incremental Delay, d2	1.4	3.0		1.1	8.7		7.9	0.9			0.4	
Delay (s)	6.9	11.6		6.8	20.2		39.5	30.7			29.3	
Level of Service	A	B		A	C		D	C			C	
Approach Delay (s)		11.4			19.3			35.3			29.3	
Approach LOS		B			B			D			C	
<b>Intersection Summary</b>												
HCM 2000 Control Delay			19.6				HCM 2000 Level of Service				B	
HCM 2000 Volume to Capacity ratio			0.81									
Actuated Cycle Length (s)			85.0				Sum of lost time (s)			12.5		
Intersection Capacity Utilization			89.0%				ICU Level of Service			E		
Analysis Period (min)			15									

c Critical Lane Group

# HCM Signalized Intersection Capacity Analysis

## 2: Alpine Ave/1460 Richmond & Carling Ave

Future Background (2029)  
PM Peak Hour



Movement	EBL	EBT	EBR	WBL	WBT	WBR	NBL	NBT	NBR	SBL	SBT	SBR
Lane Configurations	↗	↑↑↑		↗	↑↑↑			↕			↕	
Traffic Volume (vph)	29	1345	10	57	2174	85	21	16	33	53	19	40
Future Volume (vph)	29	1345	10	57	2174	85	21	16	33	53	19	40
Ideal Flow (vphpl)	1800	1800	1800	1800	1800	1800	1800	1800	1800	1800	1800	1800
Lane Width	3.0	3.6	3.7	3.0	3.7	3.7	3.7	4.8	3.7	3.7	3.6	3.7
Total Lost time (s)	5.9	5.9		5.9	5.9			6.7			6.7	
Lane Util. Factor	1.00	0.91		1.00	0.91			1.00			1.00	
Frbp, ped/bikes	1.00	1.00		1.00	1.00			0.98			0.98	
Flpb, ped/bikes	1.00	1.00		1.00	1.00			0.99			0.99	
Frt	1.00	1.00		1.00	0.99			0.94			0.95	
Flt Protected	0.95	1.00		0.95	1.00			0.99			0.98	
Satd. Flow (prot)	1596	4760		1549	4821			1742			1609	
Flt Permitted	0.05	1.00		0.17	1.00			0.85			0.84	
Satd. Flow (perm)	89	4760		273	4821			1498			1380	
Peak-hour factor, PHF	1.00	1.00	1.00	1.00	1.00	1.00	1.00	1.00	1.00	1.00	1.00	1.00
Adj. Flow (vph)	29	1345	10	57	2174	85	21	16	33	53	19	40
RTOR Reduction (vph)	0	0	0	0	2	0	0	29	0	0	19	0
Lane Group Flow (vph)	29	1355	0	57	2257	0	0	41	0	0	93	0
Confl. Peds. (#/hr)	40		13	13		40	32		14	14		32
Heavy Vehicles (%)	0%	2%	0%	3%	1%	0%	12%	0%	4%	3%	0%	0%
Bus Blockages (#/hr)	0	8	0	0	8	0	0	0	0	0	0	0
Turn Type	pm+pt	NA		pm+pt	NA		Perm	NA		Perm	NA	
Protected Phases	5	2		1	6			8			4	
Permitted Phases	2			6			8			4		
Actuated Green, G (s)	95.1	91.3		98.5	93.0			14.7			14.7	
Effective Green, g (s)	95.1	91.3		98.5	93.0			14.7			14.7	
Actuated g/C Ratio	0.73	0.70		0.76	0.72			0.11			0.11	
Clearance Time (s)	5.9	5.9		5.9	5.9			6.7			6.7	
Vehicle Extension (s)	3.0	3.0		3.0	3.0			3.0			3.0	
Lane Grp Cap (vph)	109	3342		260	3448			169			156	
v/s Ratio Prot	0.01	0.28		c0.01	c0.47							
v/s Ratio Perm	0.19			0.16				0.03			c0.07	
v/c Ratio	0.27	0.41		0.22	0.65			0.24			0.60	
Uniform Delay, d1	7.7	8.1		4.5	9.9			52.6			54.8	
Progression Factor	2.39	1.16		1.18	0.72			1.00			1.00	
Incremental Delay, d2	1.2	0.3		0.3	0.7			0.7			6.1	
Delay (s)	19.5	9.7		5.6	7.8			53.3			60.9	
Level of Service	B	A		A	A			D			E	
Approach Delay (s)		9.9			7.8			53.3			60.9	
Approach LOS		A			A			D			E	

### Intersection Summary

HCM 2000 Control Delay	10.9	HCM 2000 Level of Service	B
HCM 2000 Volume to Capacity ratio	0.64		
Actuated Cycle Length (s)	130.0	Sum of lost time (s)	18.5
Intersection Capacity Utilization	84.3%	ICU Level of Service	E
Analysis Period (min)	15		

c Critical Lane Group

# HCM Signalized Intersection Capacity Analysis

## 3: Carling Ave & Croydon Ave

Future Background (2029)  
PM Peak Hour

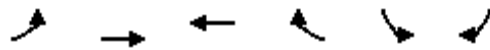

Movement	EBL	EBT	WBT	WBR	SBL	SBR
Lane Configurations	↵	↑↑↑	↑↑↑		↵↵	
Traffic Volume (vph)	96	1374	2360	157	180	115
Future Volume (vph)	96	1374	2360	157	180	115
Ideal Flow (vphpl)	1800	1800	1800	1800	1800	1800
Lane Width	2.8	3.6	3.7	3.7	3.7	3.3
Total Lost time (s)	5.9	5.9	5.9		6.3	
Lane Util. Factor	1.00	0.91	0.91		0.97	
Frpb, ped/bikes	1.00	1.00	0.99		0.98	
Flpb, ped/bikes	1.00	1.00	1.00		1.00	
Frt	1.00	1.00	0.99		0.94	
Flt Protected	0.95	1.00	1.00		0.97	
Satd. Flow (prot)	1527	4696	4700		3101	
Flt Permitted	0.04	1.00	1.00		0.97	
Satd. Flow (perm)	68	4696	4700		3101	
Peak-hour factor, PHF	1.00	1.00	1.00	1.00	1.00	1.00
Adj. Flow (vph)	96	1374	2360	157	180	115
RTOR Reduction (vph)	0	0	4	0	100	0
Lane Group Flow (vph)	96	1374	2513	0	195	0
Confl. Peds. (#/hr)	39			39	3	22
Heavy Vehicles (%)	2%	2%	1%	5%	4%	0%
Bus Blockages (#/hr)	0	19	19	0	0	0
Turn Type	pm+pt	NA	NA		Prot	
Protected Phases	5	2	6		7	
Permitted Phases	2					
Actuated Green, G (s)	104.2	104.2	88.9		13.6	
Effective Green, g (s)	104.2	104.2	88.9		13.6	
Actuated g/C Ratio	0.80	0.80	0.68		0.10	
Clearance Time (s)	5.9	5.9	5.9		6.3	
Vehicle Extension (s)	3.0	3.0	3.0		3.0	
Lane Grp Cap (vph)	160	3764	3214		324	
v/s Ratio Prot	c0.04	0.29	c0.53		c0.06	
v/s Ratio Perm	0.44					
v/c Ratio	0.60	0.37	0.78		0.60	
Uniform Delay, d1	30.1	3.6	14.0		55.6	
Progression Factor	1.76	0.36	1.00		1.00	
Incremental Delay, d2	5.6	0.3	2.0		3.1	
Delay (s)	58.5	1.6	15.9		58.7	
Level of Service	E	A	B		E	
Approach Delay (s)		5.3	15.9		58.7	
Approach LOS		A	B		E	

Intersection Summary			
HCM 2000 Control Delay	15.2	HCM 2000 Level of Service	B
HCM 2000 Volume to Capacity ratio	0.75		
Actuated Cycle Length (s)	130.0	Sum of lost time (s)	18.1
Intersection Capacity Utilization	91.0%	ICU Level of Service	E
Analysis Period (min)	15		

c Critical Lane Group



HCM Unsignalized Intersection Capacity Analysis  
4: Carling Ave & Forest St

Future Background (2029)  
PM Peak Hour



Movement	EBL	EBT	WBT	WBR	SBL	SBR	
Lane Configurations		↑↑↑	↑↑↑			↑	
Traffic Volume (veh/h)	0	1430	2200	40	0	115	
Future Volume (Veh/h)	0	1430	2200	40	0	115	
Sign Control		Free	Free		Stop		
Grade		0%	0%		0%		
Peak Hour Factor	1.00	1.00	1.00	1.00	1.00	1.00	
Hourly flow rate (vph)	0	1430	2200	40	0	115	
Pedestrians							
Lane Width (m)							
Walking Speed (m/s)							
Percent Blockage							
Right turn flare (veh)							
Median type		None	None				
Median storage (veh)							
Upstream signal (m)		55	141				
pX, platoon unblocked	0.65				0.71	0.65	
vC, conflicting volume	2240				2697	753	
vC1, stage 1 conf vol							
vC2, stage 2 conf vol							
vCu, unblocked vol	1027				857	0	
tC, single (s)	4.1				6.8	6.9	
tC, 2 stage (s)							
tF (s)	2.2				3.5	3.3	
p0 queue free %	100				100	84	
cM capacity (veh/h)	445				213	710	
Direction, Lane #	EB 1	EB 2	EB 3	WB 1	WB 2	WB 3	SB 1
Volume Total	477	477	477	880	880	480	115
Volume Left	0	0	0	0	0	0	0
Volume Right	0	0	0	0	0	40	115
cSH	1700	1700	1700	1700	1700	1700	710
Volume to Capacity	0.28	0.28	0.28	0.52	0.52	0.28	0.16
Queue Length 95th (m)	0.0	0.0	0.0	0.0	0.0	0.0	4.4
Control Delay (s)	0.0	0.0	0.0	0.0	0.0	0.0	11.0
Lane LOS							B
Approach Delay (s)	0.0			0.0			11.0
Approach LOS							B
Intersection Summary							
Average Delay			0.3				
Intersection Capacity Utilization			60.0%		ICU Level of Service		B
Analysis Period (min)			15				

HCM Unsignalized Intersection Capacity Analysis  
5: Croydon Ave & Bond St









Future Background (2029)  
PM Peak Hour



Movement	EBL	EBR	NBL	NBT	SBT	SBR
Lane Configurations						
Traffic Volume (veh/h)	2	14	13	239	281	14
Future Volume (Veh/h)	2	14	13	239	281	14
Sign Control	Stop			Free	Free	
Grade	0%			0%	0%	
Peak Hour Factor	1.00	1.00	1.00	1.00	1.00	1.00
Hourly flow rate (vph)	2	14	13	239	281	14
<b>Pedestrians</b>						
Lane Width (m)						
Walking Speed (m/s)						
Percent Blockage						
Right turn flare (veh)						
Median type				None	None	
Median storage veh						
Upstream signal (m)				78	181	
pX, platoon unblocked						
vC, conflicting volume	553	288	295			
vC1, stage 1 conf vol						
vC2, stage 2 conf vol						
vCu, unblocked vol	553	288	295			
tC, single (s)	6.4	6.2	4.1			
tC, 2 stage (s)						
tF (s)	3.5	3.3	2.2			
p0 queue free %	100	98	99			
cM capacity (veh/h)	492	756	1278			
<b>Direction, Lane #</b>	<b>EB 1</b>	<b>NB 1</b>	<b>SB 1</b>			
Volume Total	16	252	295			
Volume Left	2	13	0			
Volume Right	14	0	14			
cSH	708	1278	1700			
Volume to Capacity	0.02	0.01	0.17			
Queue Length 95th (m)	0.5	0.2	0.0			
Control Delay (s)	10.2	0.5	0.0			
Lane LOS	B	A				
Approach Delay (s)	10.2	0.5	0.0			
Approach LOS	B					
<b>Intersection Summary</b>						
Average Delay				0.5		
Intersection Capacity Utilization				34.5%	ICU Level of Service	A
Analysis Period (min)				15		

HCM Unsignalized Intersection Capacity Analysis  
6: Forest St & Bond St

Future Background (2029)  
PM Peak Hour

						
Movement	WBL	WBR	NBT	NBR	SBL	SBT
Lane Configurations						
Traffic Volume (veh/h)	2	10	40	2	30	114
Future Volume (Veh/h)	2	10	40	2	30	114
Sign Control	Stop		Free		Free	
Grade	0%		0%		0%	
Peak Hour Factor	1.00	1.00	1.00	1.00	1.00	1.00
Hourly flow rate (vph)	2	10	40	2	30	114
<b>Pedestrians</b>						
Lane Width (m)						
Walking Speed (m/s)						
Percent Blockage						
Right turn flare (veh)						
Median type	None			None		
Median storage veh)						
Upstream signal (m)						
pX, platoon unblocked						
vC, conflicting volume	215	41			42	
vC1, stage 1 conf vol						
vC2, stage 2 conf vol						
vCu, unblocked vol	215	41			42	
tC, single (s)	6.4	6.2			4.1	
tC, 2 stage (s)						
tF (s)	3.5	3.3			2.2	
p0 queue free %	100	99			98	
cM capacity (veh/h)	763	1036			1580	
<b>Direction, Lane #</b>	<b>WB 1</b>	<b>NB 1</b>	<b>SB 1</b>			
Volume Total	12	42	144			
Volume Left	2	0	30			
Volume Right	10	2	0			
cSH	978	1700	1580			
Volume to Capacity	0.01	0.02	0.02			
Queue Length 95th (m)	0.3	0.0	0.4			
Control Delay (s)	8.7	0.0	1.6			
Lane LOS	A		A			
Approach Delay (s)	8.7	0.0	1.6			
Approach LOS	A					
<b>Intersection Summary</b>						
Average Delay			1.7			
Intersection Capacity Utilization			24.8%	ICU Level of Service	A	
Analysis Period (min)			15			

HCM Unsignalized Intersection Capacity Analysis  
7: Forest St & Richmond Rd



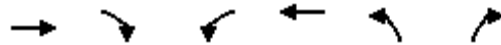





















Future Background (2029)  
PM Peak Hour



Movement	EBT	EBR	WBL	WBT	NBL	NBR
Lane Configurations	→			←	↘	↙
Traffic Volume (veh/h)	657	13	54	1036	13	32
Future Volume (Veh/h)	657	13	54	1036	13	32
Sign Control	Free			Free	Stop	
Grade	0%			0%	0%	
Peak Hour Factor	1.00	1.00	1.00	1.00	1.00	1.00
Hourly flow rate (vph)	657	13	54	1036	13	32
Pedestrians						
Lane Width (m)						
Walking Speed (m/s)						
Percent Blockage						
Right turn flare (veh)						
Median type	None		None			
Median storage veh						
Upstream signal (m)	279			154		
pX, platoon unblocked			0.89		0.50	0.89
vC, conflicting volume			670		1808	664
vC1, stage 1 conf vol						
vC2, stage 2 conf vol						
vCu, unblocked vol			570		1630	563
tC, single (s)			4.1		6.4	6.2
tC, 2 stage (s)						
tF (s)			2.2		3.5	3.3
p0 queue free %			94		76	93
cM capacity (veh/h)			904		54	473
Direction, Lane #	EB 1	WB 1	NB 1			
Volume Total	670	1090	45			
Volume Left	0	54	13			
Volume Right	13	0	32			
cSH	1700	904	145			
Volume to Capacity	0.39	0.06	0.31			
Queue Length 95th (m)	0.0	1.4	9.3			
Control Delay (s)	0.0	1.8	40.7			
Lane LOS			A	E		
Approach Delay (s)	0.0	1.8	40.7			
Approach LOS			E			
Intersection Summary						
Average Delay			2.1			
Intersection Capacity Utilization			111.4%	ICU Level of Service		H
Analysis Period (min)			15			





















HCM Signalized Intersection Capacity Analysis  
9: Richmond Rd & Carling Ave

Future Background (2029)  
PM Peak Hour

													
Movement	EBL	EBT	EBR	WBL	WBT	WBR	NBL	NBT	NBR	SBL	SBT	SBR	
Lane Configurations		 			  			 			 		
Traffic Volume (vph)	278	821	3	15	2095	2	0	546	562	0	859	391	
Future Volume (vph)	278	821	3	15	2095	2	0	546	562	0	859	391	
Ideal Flow (vphpl)	1800	1800	1800	1800	1800	1800	1800	1800	1800	1800	1800	1800	
Total Lost time (s)	6.0	5.8		6.0	5.8			7.0	4.0		7.0	4.0	
Lane Util. Factor	1.00	0.95		1.00	0.91			0.95	1.00		0.95	1.00	
Frpb, ped/bikes	1.00	1.00		1.00	1.00			1.00	0.99		1.00	0.99	
Flpb, ped/bikes	1.00	1.00		1.00	1.00			1.00	1.00		1.00	1.00	
Frt	1.00	1.00		1.00	1.00			1.00	0.85		1.00	0.85	
Flt Protected	0.95	1.00		0.95	1.00			1.00	1.00		1.00	1.00	
Satd. Flow (prot)	1695	3388		988	4919			3390	1496		3357	1497	
Flt Permitted	0.95	1.00		0.95	1.00			1.00	1.00		1.00	1.00	
Satd. Flow (perm)	1695	3388		988	4919			3390	1496		3357	1497	
Peak-hour factor, PHF	1.00	1.00	1.00	1.00	1.00	1.00	1.00	1.00	1.00	1.00	1.00	1.00	
Adj. Flow (vph)	278	821	3	15	2095	2	0	546	562	0	859	391	
RTOR Reduction (vph)	0	0	0	0	0	0	0	0	0	0	0	0	
Lane Group Flow (vph)	278	824	0	15	2097	0	0	546	562	0	859	391	
Confl. Peds. (#/hr)	7		2	2		7	2		3	3		2	
Confl. Bikes (#/hr)	7		2	2		7	2		3	3		2	
Heavy Vehicles (%)	2%	2%	0%	75%	1%	0%	2%	2%	2%	2%	3%	2%	
Turn Type	Prot	NA		Prot	NA			NA	Free		NA	Free	
Protected Phases	5	2		19	6			8			4		
Permitted Phases									Free			Free	
Actuated Green, G (s)	23.1	61.8		6.0	50.7			37.4	130.0		37.4	130.0	
Effective Green, g (s)	23.1	61.8		6.0	50.7			37.4	130.0		37.4	130.0	
Actuated g/C Ratio	0.18	0.48		0.05	0.39			0.29	1.00		0.29	1.00	
Clearance Time (s)	6.0	5.8			5.8			7.0			7.0		
Vehicle Extension (s)	3.0	3.0			3.0			3.0			3.0		
Lane Grp Cap (vph)	301	1610		45	1918			975	1496		965	1497	
v/s Ratio Prot	c0.16	0.24		0.02	c0.43			0.16			c0.26		
v/s Ratio Perm									0.38			0.26	
v/c Ratio	0.92	0.51		0.33	1.09			0.56	0.38		0.89	0.26	
Uniform Delay, d1	52.6	23.6		60.1	39.6			39.3	0.0		44.3	0.0	
Progression Factor	1.00	1.00		0.94	0.65			1.00	1.00		1.00	1.00	
Incremental Delay, d2	32.4	1.2		3.6	49.7			0.7	0.7		10.3	0.4	
Delay (s)	85.0	24.8		60.3	75.5			40.1	0.7		54.6	0.4	
Level of Service	F	C		E	E			D	A		D	A	
Approach Delay (s)		40.0			75.4			20.1			37.7		
Approach LOS		D			E			C			D		
<b>Intersection Summary</b>													
HCM 2000 Control Delay			48.9									HCM 2000 Level of Service	D
HCM 2000 Volume to Capacity ratio			1.05										
Actuated Cycle Length (s)			130.0									Sum of lost time (s)	24.8
Intersection Capacity Utilization			100.2%									ICU Level of Service	G
Analysis Period (min)			15										
c Critical Lane Group													

HCM Signalized Intersection Capacity Analysis  
10: Poulin St & Richmond Rd





















Future Background (2029)  
PM Peak Hour

													
Movement	EBL	EBT	EBR	WBL	WBT	WBR	NBL	NBT	NBR	SBL	SBT	SBR	
Lane Configurations													
Traffic Volume (vph)	249	526	3	0	1054	50	47	66	15	81	2	149	
Future Volume (vph)	249	526	3	0	1054	50	47	66	15	81	2	149	
Ideal Flow (vphpl)	1800	1800	1800	1800	1800	1800	1800	1800	1800	1800	1800	1800	
Total Lost time (s)	6.3	6.3			6.3			6.2			6.2	6.2	
Lane Util. Factor	1.00	1.00			0.95			1.00			1.00	1.00	
Frbp, ped/bikes	1.00	1.00			1.00			0.99			1.00	0.98	
Flpb, ped/bikes	1.00	1.00			1.00			1.00			0.99	1.00	
Frt	1.00	1.00			0.99			0.98			1.00	0.85	
Flt Protected	0.95	1.00			1.00			0.98			0.95	1.00	
Satd. Flow (prot)	1729	1818			3429			1748			1722	1521	
Flt Permitted	0.14	1.00			1.00			0.84			0.63	1.00	
Satd. Flow (perm)	249	1818			3429			1503			1145	1521	
Peak-hour factor, PHF	1.00	1.00	1.00	1.00	1.00	1.00	1.00	1.00	1.00	1.00	1.00	1.00	
Adj. Flow (vph)	249	526	3	0	1054	50	47	66	15	81	2	149	
RTOR Reduction (vph)	0	0	0	0	3	0	0	7	0	0	0	128	
Lane Group Flow (vph)	249	529	0	0	1101	0	0	121	0	0	83	21	
Confl. Peds. (#/hr)	6		16	16		6	2		6	6		2	
Confl. Bikes (#/hr)	6		16	16		6	2		6	6		2	
Heavy Vehicles (%)	0%	0%	0%	2%	0%	0%	0%	0%	0%	0%	0%	0%	
Turn Type	pm+pt	NA			NA		Perm	NA		Perm	NA	Perm	
Protected Phases	5	2			6			8			4		
Permitted Phases	2						8			4		4	
Actuated Green, G (s)	64.6	64.6			42.2			12.9			12.9	12.9	
Effective Green, g (s)	64.6	64.6			42.2			12.9			12.9	12.9	
Actuated g/C Ratio	0.72	0.72			0.47			0.14			0.14	0.14	
Clearance Time (s)	6.3	6.3			6.3			6.2			6.2	6.2	
Vehicle Extension (s)	3.0	3.0			3.0			3.0			3.0	3.0	
Lane Grp Cap (vph)	443	1304			1607			215			164	218	
v/s Ratio Prot	c0.10	0.29			c0.32								
v/s Ratio Perm	0.30							c0.08			0.07	0.01	
v/c Ratio	0.56	0.41			0.69			0.56			0.51	0.10	
Uniform Delay, d1	10.3	5.1			18.7			35.9			35.6	33.5	
Progression Factor	1.00	1.00			1.00			1.00			1.00	1.00	
Incremental Delay, d2	1.6	0.9			2.4			3.4			2.4	0.2	
Delay (s)	12.0	6.0			21.1			39.3			38.1	33.7	
Level of Service	B	A			C			D			D	C	
Approach Delay (s)		7.9			21.1			39.3			35.3		
Approach LOS		A			C			D			D		
<b>Intersection Summary</b>													
HCM 2000 Control Delay			19.0									HCM 2000 Level of Service	B
HCM 2000 Volume to Capacity ratio			0.64										
Actuated Cycle Length (s)			90.0									Sum of lost time (s)	18.8
Intersection Capacity Utilization			78.3%									ICU Level of Service	D
Analysis Period (min)			15										
c Critical Lane Group													

## Appendix G – Future Total Traffic Level of Service Outputs

HCM Signalized Intersection Capacity Analysis  
 1: Croydon Ave & Richmond Rd

Future Total (2024)  
 AM Peak Hour

												
Movement	EBL	EBT	EBR	WBL	WBT	WBR	NBL	NBT	NBR	SBL	SBT	SBR
Lane Configurations												
Traffic Volume (vph)	23	573	69	18	379	17	38	29	81	28	72	38
Future Volume (vph)	23	573	69	18	379	17	38	29	81	28	72	38
Ideal Flow (vphpl)	1800	1800	1800	1800	1800	1800	1800	1800	1800	1800	1800	1800
Lane Width	3.4	3.4	3.7	3.0	3.4	3.7	3.5	3.5	3.7	3.7	4.8	3.7
Total Lost time (s)	6.4	6.4		6.4	6.4		6.1	6.1			6.1	
Lane Util. Factor	1.00	1.00		1.00	1.00		1.00	1.00			1.00	
Frbp, ped/bikes	1.00	1.00		1.00	1.00		1.00	0.94			0.98	
Flpb, ped/bikes	0.98	1.00		0.99	1.00		0.97	1.00			0.99	
Frnt	1.00	0.98		1.00	0.99		1.00	0.89			0.96	
Flt Protected	0.95	1.00		0.95	1.00		0.95	1.00			0.99	
Satd. Flow (prot)	1559	1573		1581	1584		1388	1390			1848	
Flt Permitted	0.53	1.00		0.37	1.00		0.68	1.00			0.90	
Satd. Flow (perm)	867	1573		620	1584		999	1390			1680	
Peak-hour factor, PHF	1.00	1.00	1.00	1.00	1.00	1.00	1.00	1.00	1.00	1.00	1.00	1.00
Adj. Flow (vph)	23	573	69	18	379	17	38	29	81	28	72	38
RTOR Reduction (vph)	0	4	0	0	1	0	0	70	0	0	26	0
Lane Group Flow (vph)	23	638	0	18	395	0	38	40	0	0	112	0
Confl. Peds. (#/hr)	21		15	15		21	29		41	41		29
Heavy Vehicles (%)	5%	4%	15%	0%	6%	0%	18%	20%	3%	4%	0%	6%
Bus Blockages (#/hr)	0	10	0	0	10	0	0	0	0	0	0	0
Turn Type	Perm	NA		Perm	NA		Perm	NA		Perm	NA	
Protected Phases		2			6			8			4	
Permitted Phases	2			6			8			4		
Actuated Green, G (s)	48.4	48.4		48.4	48.4		9.1	9.1			9.1	
Effective Green, g (s)	48.4	48.4		48.4	48.4		9.1	9.1			9.1	
Actuated g/C Ratio	0.69	0.69		0.69	0.69		0.13	0.13			0.13	
Clearance Time (s)	6.4	6.4		6.4	6.4		6.1	6.1			6.1	
Vehicle Extension (s)	3.0	3.0		3.0	3.0		3.0	3.0			3.0	
Lane Grp Cap (vph)	599	1087		428	1095		129	180			218	
v/s Ratio Prot		c0.41			0.25			0.03				
v/s Ratio Perm	0.03			0.03			0.04				c0.07	
v/c Ratio	0.04	0.59		0.04	0.36		0.29	0.22			0.51	
Uniform Delay, d1	3.4	5.6		3.4	4.4		27.5	27.3			28.4	
Progression Factor	1.00	1.00		1.00	1.00		1.00	1.00			1.00	
Incremental Delay, d2	0.1	2.3		0.2	0.9		1.3	0.6			2.0	
Delay (s)	3.5	7.9		3.6	5.4		28.8	27.9			30.4	
Level of Service	A	A		A	A		C	C			C	
Approach Delay (s)		7.8			5.3			28.1			30.4	
Approach LOS		A			A			C			C	
<b>Intersection Summary</b>												
HCM 2000 Control Delay			11.5				HCM 2000 Level of Service				B	
HCM 2000 Volume to Capacity ratio			0.58									
Actuated Cycle Length (s)			70.0				Sum of lost time (s)				12.5	
Intersection Capacity Utilization			65.6%				ICU Level of Service				C	
Analysis Period (min)			15									

c Critical Lane Group



HCM Signalized Intersection Capacity Analysis  
 2: Alpine Ave/1460 Richmond & Carling Ave

Future Total (2024)  
 AM Peak Hour



Movement	EBL	EBT	EBR	WBL	WBT	WBR	NBL	NBT	NBR	SBL	SBT	SBR
Lane Configurations	↗	↑↑↑		↗	↑↑↑			↕			↕	
Traffic Volume (vph)	33	2754	6	34	956	76	25	8	97	41	9	52
Future Volume (vph)	33	2754	6	34	956	76	25	8	97	41	9	52
Ideal Flow (vphpl)	1800	1800	1800	1800	1800	1800	1800	1800	1800	1800	1800	1800
Lane Width	3.0	3.6	3.7	3.0	3.7	3.7	3.7	4.8	3.7	3.7	3.6	3.7
Total Lost time (s)	5.9	5.9		5.9	5.9			6.7			6.7	
Lane Util. Factor	1.00	0.91		1.00	0.91			1.00			1.00	
Frbp, ped/bikes	1.00	1.00		1.00	0.99			0.96			0.99	
Flpb, ped/bikes	0.98	1.00		1.00	1.00			1.00			0.99	
Frt	1.00	1.00		1.00	0.99			0.90			0.93	
Flt Protected	0.95	1.00		0.95	1.00			0.99			0.98	
Satd. Flow (prot)	1504	4764		1596	4643			1674			1570	
Flt Permitted	0.27	1.00		0.04	1.00			0.89			0.67	
Satd. Flow (perm)	420	4764		67	4643			1501			1065	
Peak-hour factor, PHF	1.00	1.00	1.00	1.00	1.00	1.00	1.00	1.00	1.00	1.00	1.00	1.00
Adj. Flow (vph)	33	2754	6	34	956	76	25	8	97	41	9	52
RTOR Reduction (vph)	0	0	0	0	4	0	0	68	0	0	36	0
Lane Group Flow (vph)	33	2760	0	34	1028	0	0	62	0	0	66	0
Confl. Peds. (#/hr)	36		27	27		36	11		27	27		11
Heavy Vehicles (%)	4%	2%	0%	0%	4%	3%	10%	0%	3%	3%	0%	2%
Bus Blockages (#/hr)	0	8	0	0	8	0	0	0	0	0	0	0
Turn Type	Perm	NA		pm+pt	NA		Perm	NA		Perm	NA	
Protected Phases		2		1	6			8				4
Permitted Phases	2			6			8			4		
Actuated Green, G (s)	94.8	94.8		104.5	104.5			12.9			12.9	
Effective Green, g (s)	94.8	94.8		104.5	104.5			12.9			12.9	
Actuated g/C Ratio	0.73	0.73		0.80	0.80			0.10			0.10	
Clearance Time (s)	5.9	5.9		5.9	5.9			6.7			6.7	
Vehicle Extension (s)	3.0	3.0		3.0	3.0			3.0			3.0	
Lane Grp Cap (vph)	306	3474		98	3732			148			105	
v/s Ratio Prot		c0.58		0.01	c0.22							
v/s Ratio Perm	0.08			0.27				0.04			c0.06	
v/c Ratio	0.11	0.79		0.35	0.28			0.42			0.63	
Uniform Delay, d1	5.2	11.3		13.4	3.2			55.0			56.2	
Progression Factor	0.51	0.53		3.71	0.84			1.00			1.00	
Incremental Delay, d2	0.4	1.1		2.1	0.2			1.9			11.2	
Delay (s)	3.0	7.1		51.9	2.9			57.0			67.4	
Level of Service	A	A		D	A			E			E	
Approach Delay (s)		7.0			4.5			57.0			67.4	
Approach LOS		A			A			E			E	

Intersection Summary		
HCM 2000 Control Delay	9.5	HCM 2000 Level of Service
HCM 2000 Volume to Capacity ratio	0.77	A
Actuated Cycle Length (s)	130.0	Sum of lost time (s)
Intersection Capacity Utilization	84.7%	18.5
Analysis Period (min)	15	ICU Level of Service
		E

c Critical Lane Group

HCM Signalized Intersection Capacity Analysis  
 3: Carling Ave & Croydon Ave

Future Total (2024)  
 AM Peak Hour

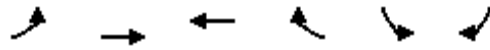

Movement	EBL	EBT	WBT	WBR	SBL	SBR
Lane Configurations	↶	↑↑↑	↑↑↑		↶↶	
Traffic Volume (vph)	109	2253	930	102	184	28
Future Volume (vph)	109	2253	930	102	184	28
Ideal Flow (vphpl)	1800	1800	1800	1800	1800	1800
Lane Width	2.8	3.6	3.7	3.7	3.7	3.3
Total Lost time (s)	5.9	5.9	5.9		6.3	
Lane Util. Factor	1.00	0.91	0.91		0.97	
Frpb, ped/bikes	1.00	1.00	0.99		1.00	
Flpb, ped/bikes	1.00	1.00	1.00		1.00	
Frt	1.00	1.00	0.99		0.98	
Flt Protected	0.95	1.00	1.00		0.96	
Satd. Flow (prot)	1525	4696	4585		3112	
Flt Permitted	0.24	1.00	1.00		0.96	
Satd. Flow (perm)	380	4696	4585		3112	
Peak-hour factor, PHF	1.00	1.00	1.00	1.00	1.00	1.00
Adj. Flow (vph)	109	2253	930	102	184	28
RTOR Reduction (vph)	0	0	7	0	12	0
Lane Group Flow (vph)	109	2253	1025	0	200	0
Confl. Peds. (#/hr)	16			16	2	19
Heavy Vehicles (%)	2%	2%	3%	7%	7%	0%
Bus Blockages (#/hr)	0	19	19	0	0	0
Turn Type	pm+pt	NA	NA		Prot	
Protected Phases	5	2	6		7	
Permitted Phases	2					
Actuated Green, G (s)	104.0	104.0	90.5		13.8	
Effective Green, g (s)	104.0	104.0	90.5		13.8	
Actuated g/C Ratio	0.80	0.80	0.70		0.11	
Clearance Time (s)	5.9	5.9	5.9		6.3	
Vehicle Extension (s)	3.0	3.0	3.0		3.0	
Lane Grp Cap (vph)	370	3756	3191		330	
v/s Ratio Prot	0.02	c0.48	0.22		c0.06	
v/s Ratio Perm	0.22					
v/c Ratio	0.29	0.60	0.32		0.61	
Uniform Delay, d1	3.4	5.0	7.7		55.5	
Progression Factor	0.58	0.35	1.00		1.00	
Incremental Delay, d2	0.3	0.5	0.3		3.1	
Delay (s)	2.2	2.2	8.0		58.7	
Level of Service	A	A	A		E	
Approach Delay (s)		2.2	8.0		58.7	
Approach LOS		A	A		E	

Intersection Summary				
HCM 2000 Control Delay		7.2	HCM 2000 Level of Service	A
HCM 2000 Volume to Capacity ratio		0.63		
Actuated Cycle Length (s)		130.0	Sum of lost time (s)	18.1
Intersection Capacity Utilization		72.7%	ICU Level of Service	C
Analysis Period (min)		15		

c Critical Lane Group

# HCM Unsignalized Intersection Capacity Analysis

## 4: Carling Ave & Forest St

Future Total (2024)  
AM Peak Hour

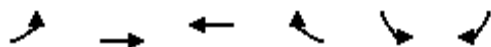

Movement	EBL	EBT	WBT	WBR	SBL	SBR	
Lane Configurations		↑↑↑	↑↑↑			↑	
Traffic Volume (veh/h)	0	2895	1002	25	0	62	
Future Volume (Veh/h)	0	2895	1002	25	0	62	
Sign Control		Free	Free		Stop		
Grade		0%	0%		0%		
Peak Hour Factor	1.00	1.00	1.00	1.00	1.00	1.00	
Hourly flow rate (vph)	0	2895	1002	25	0	62	
<b>Pedestrians</b>							
Lane Width (m)							
Walking Speed (m/s)							
Percent Blockage							
Right turn flare (veh)							
Median type		None	None				
Median storage (veh)							
Upstream signal (m)		55	141				
pX, platoon unblocked	0.93				0.65	0.93	
vC, conflicting volume	1027				1980	346	
vC1, stage 1 conf vol							
vC2, stage 2 conf vol							
vCu, unblocked vol	777				0	48	
tC, single (s)	4.1				6.8	6.9	
tC, 2 stage (s)							
tF (s)	2.2				3.5	3.3	
p0 queue free %	100				100	93	
cM capacity (veh/h)	791				667	949	
Direction, Lane #	EB 1	EB 2	EB 3	WB 1	WB 2	WB 3	SB 1
Volume Total	965	965	965	401	401	225	62
Volume Left	0	0	0	0	0	0	0
Volume Right	0	0	0	0	0	25	62
cSH	1700	1700	1700	1700	1700	1700	949
Volume to Capacity	0.57	0.57	0.57	0.24	0.24	0.13	0.07
Queue Length 95th (m)	0.0	0.0	0.0	0.0	0.0	0.0	1.6
Control Delay (s)	0.0	0.0	0.0	0.0	0.0	0.0	9.1
Lane LOS							A
Approach Delay (s)	0.0			0.0			9.1
Approach LOS							A
<b>Intersection Summary</b>							
Average Delay			0.1				
Intersection Capacity Utilization			62.4%	ICU Level of Service		B	
Analysis Period (min)			15				

HCM Unsignalized Intersection Capacity Analysis  
5: Croydon Ave & Bond St









Future Total (2024)  
AM Peak Hour



Movement	EBL	EBR	NBL	NBT	SBT	SBR
Lane Configurations						
Traffic Volume (veh/h)	2	21	17	193	190	11
Future Volume (Veh/h)	2	21	17	193	190	11
Sign Control	Stop			Free	Free	
Grade	0%			0%	0%	
Peak Hour Factor	1.00	1.00	1.00	1.00	1.00	1.00
Hourly flow rate (vph)	2	21	17	193	190	11
Pedestrians						
Lane Width (m)						
Walking Speed (m/s)						
Percent Blockage						
Right turn flare (veh)						
Median type				None	None	
Median storage veh						
Upstream signal (m)				78	181	
pX, platoon unblocked						
vC, conflicting volume	422	196	201			
vC1, stage 1 conf vol						
vC2, stage 2 conf vol						
vCu, unblocked vol	422	196	201			
tC, single (s)	6.4	6.2	4.1			
tC, 2 stage (s)						
tF (s)	3.5	3.3	2.2			
p0 queue free %	100	98	99			
cM capacity (veh/h)	585	851	1383			
Direction, Lane #	EB 1	NB 1	SB 1			
Volume Total	23	210	201			
Volume Left	2	17	0			
Volume Right	21	0	11			
cSH	818	1383	1700			
Volume to Capacity	0.03	0.01	0.12			
Queue Length 95th (m)	0.7	0.3	0.0			
Control Delay (s)	9.5	0.7	0.0			
Lane LOS	A	A				
Approach Delay (s)	9.5	0.7	0.0			
Approach LOS	A					
Intersection Summary						
Average Delay			0.9			
Intersection Capacity Utilization			35.6%	ICU Level of Service	A	
Analysis Period (min)			15			

HCM Unsignalized Intersection Capacity Analysis  
6: Forest St & Bond St

Future Total (2024)  
AM Peak Hour

						
Movement	WBL	WBR	NBT	NBR	SBL	SBT
Lane Configurations						
Traffic Volume (veh/h)	11	15	25	2	15	52
Future Volume (Veh/h)	11	15	25	2	15	52
Sign Control	Stop		Free		Free	
Grade	0%		0%		0%	
Peak Hour Factor	1.00	1.00	1.00	1.00	1.00	1.00
Hourly flow rate (vph)	11	15	25	2	15	52
Pedestrians						
Lane Width (m)						
Walking Speed (m/s)						
Percent Blockage						
Right turn flare (veh)						
Median type	None			None		
Median storage veh)						
Upstream signal (m)						
pX, platoon unblocked						
vC, conflicting volume	108	26			27	
vC1, stage 1 conf vol						
vC2, stage 2 conf vol						
vCu, unblocked vol	108	26			27	
tC, single (s)	6.4	6.2			4.1	
tC, 2 stage (s)						
tF (s)	3.5	3.3			2.2	
p0 queue free %	99	99			99	
cM capacity (veh/h)	886	1056			1600	
Direction, Lane #	WB 1	NB 1	SB 1			
Volume Total	26	27	67			
Volume Left	11	0	15			
Volume Right	15	2	0			
cSH	976	1700	1600			
Volume to Capacity	0.03	0.02	0.01			
Queue Length 95th (m)	0.6	0.0	0.2			
Control Delay (s)	8.8	0.0	1.7			
Lane LOS	A		A			
Approach Delay (s)	8.8	0.0	1.7			
Approach LOS	A					
Intersection Summary						
Average Delay			2.8			
Intersection Capacity Utilization			20.4%	ICU Level of Service	A	
Analysis Period (min)			15			

HCM Unsignalized Intersection Capacity Analysis  
7: Forest St & Richmond Rd

Future Total (2024)  
AM Peak Hour

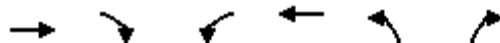

Movement	EBT	EBR	WBL	WBT	NBL	NBR
Lane Configurations	→			←	↘	↙
Traffic Volume (veh/h)	628	13	24	431	16	37
Future Volume (Veh/h)	628	13	24	431	16	37
Sign Control	Free			Free	Stop	
Grade	0%			0%	0%	
Peak Hour Factor	1.00	1.00	1.00	1.00	1.00	1.00
Hourly flow rate (vph)	628	13	24	431	16	37
Pedestrians						
Lane Width (m)						
Walking Speed (m/s)						
Percent Blockage						
Right turn flare (veh)						
Median type	None			None		
Median storage (veh)						
Upstream signal (m)	279			154		
pX, platoon unblocked			0.90	0.94	0.90	
vC, conflicting volume			641	1114	634	
vC1, stage 1 conf vol						
vC2, stage 2 conf vol						
vCu, unblocked vol			548	925	541	
tC, single (s)			4.1	6.4	6.2	
tC, 2 stage (s)						
tF (s)			2.2	3.5	3.3	
p0 queue free %			97	94	92	
cM capacity (veh/h)			931	275	492	
Direction, Lane #	EB 1	WB 1	NB 1			
Volume Total	641	455	53			
Volume Left	0	24	16			
Volume Right	13	0	37			
cSH	1700	931	397			
Volume to Capacity	0.38	0.03	0.13			
Queue Length 95th (m)	0.0	0.6	3.5			
Control Delay (s)	0.0	0.8	15.5			
Lane LOS			A	C		
Approach Delay (s)	0.0	0.8	15.5			
Approach LOS			C			
Intersection Summary						
Average Delay			1.0			
Intersection Capacity Utilization			54.6%	ICU Level of Service		A
Analysis Period (min)			15			

HCM Unsignalized Intersection Capacity Analysis  
8: Bond St & 365 Forest



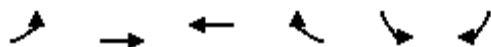

















Future Total (2024)  
AM Peak Hour



Movement	EBL	EBT	WBT	WBR	SBL	SBR
Lane Configurations		↖	↗		↘	
Traffic Volume (veh/h)	1	12	20	8	11	17
Future Volume (Veh/h)	1	12	20	8	11	17
Sign Control		Free	Free		Stop	
Grade		0%	0%		0%	
Peak Hour Factor	1.00	1.00	1.00	1.00	1.00	1.00
Hourly flow rate (vph)	1	12	20	8	11	17
Pedestrians						
Lane Width (m)						
Walking Speed (m/s)						
Percent Blockage						
Right turn flare (veh)						
Median type		None	None			
Median storage (veh)						
Upstream signal (m)						
pX, platoon unblocked						
vC, conflicting volume	28				38	24
vC1, stage 1 conf vol						
vC2, stage 2 conf vol						
vCu, unblocked vol	28				38	24
tC, single (s)	4.1				6.4	6.2
tC, 2 stage (s)						
tF (s)	2.2				3.5	3.3
p0 queue free %	100				99	98
cM capacity (veh/h)	1585				974	1052
Direction, Lane #	EB 1	WB 1	SB 1			
Volume Total	13	28	28			
Volume Left	1	0	11			
Volume Right	0	8	17			
cSH	1585	1700	1020			
Volume to Capacity	0.00	0.02	0.03			
Queue Length 95th (m)	0.0	0.0	0.6			
Control Delay (s)	0.6	0.0	8.6			
Lane LOS	A		A			
Approach Delay (s)	0.6	0.0	8.6			
Approach LOS			A			
Intersection Summary						
Average Delay			3.6			
Intersection Capacity Utilization			13.3%		ICU Level of Service	A
Analysis Period (min)			15			

HCM Signalized Intersection Capacity Analysis  
 9: Richmond Rd & Carling Ave

Future Total (2024)  
 AM Peak Hour





















												
Movement	EBL	EBT	EBR	WBL	WBT	WBR	NBL	NBT	NBR	SBL	SBT	SBR
Lane Configurations												
Traffic Volume (vph)	163	1552	0	5	1010	0	0	545	1240	0	314	197
Future Volume (vph)	163	1552	0	5	1010	0	0	545	1240	0	314	197
Ideal Flow (vphpl)	1800	1800	1800	1800	1800	1800	1800	1800	1800	1800	1800	1800
Total Lost time (s)	6.0	5.8		6.0	5.8			7.0	4.0		7.0	4.0
Lane Util. Factor	1.00	0.95		1.00	0.91			0.95	1.00		0.95	1.00
Frpb, ped/bikes	1.00	1.00		1.00	1.00			1.00	0.99		1.00	0.98
Flpb, ped/bikes	1.00	1.00		1.00	1.00			1.00	1.00		1.00	1.00
Frt	1.00	1.00		1.00	1.00			1.00	0.85		1.00	0.85
Flt Protected	0.95	1.00		0.95	1.00			1.00	1.00		1.00	1.00
Satd. Flow (prot)	1679	3369		864	4772			3325	1495		3325	1479
Flt Permitted	0.95	1.00		0.95	1.00			1.00	1.00		1.00	1.00
Satd. Flow (perm)	1679	3369		864	4772			3325	1495		3325	1479
Peak-hour factor, PHF	1.00	1.00	1.00	1.00	1.00	1.00	1.00	1.00	1.00	1.00	1.00	1.00
Adj. Flow (vph)	163	1552	0	5	1010	0	0	545	1240	0	314	197
RTOR Reduction (vph)	0	0	0	0	0	0	0	0	0	0	0	0
Lane Group Flow (vph)	163	1552	0	5	1010	0	0	545	1240	0	314	197
Confl. Peds. (#/hr)	8		7	7		8	6		4	4		6
Confl. Bikes (#/hr)	8		7	7		8	6		4	4		6
Heavy Vehicles (%)	3%	1%	0%	100%	3%	0%	0%	4%	2%	0%	4%	3%
Bus Blockages (#/hr)	0	8	0	0	8	0	0	0	0	0	0	0
Turn Type	Prot	NA		Prot	NA			NA	Free		NA	Free
Protected Phases	5	2		19	6			8			4	
Permitted Phases									Free			Free
Actuated Green, G (s)	17.6	63.2		3.0	54.6			39.0	130.0		39.0	130.0
Effective Green, g (s)	17.6	63.2		3.0	54.6			39.0	130.0		39.0	130.0
Actuated g/C Ratio	0.14	0.49		0.02	0.42			0.30	1.00		0.30	1.00
Clearance Time (s)	6.0	5.8			5.8			7.0			7.0	
Vehicle Extension (s)	3.0	3.0			3.0			3.0			3.0	
Lane Grp Cap (vph)	227	1637		19	2004			997	1495		997	1479
v/s Ratio Prot	0.10	c0.46		0.01	0.21			0.16			0.09	
v/s Ratio Perm									c0.83			0.13
v/c Ratio	0.72	0.95		0.26	0.50			0.55	0.83		0.31	0.13
Uniform Delay, d1	53.8	31.8		62.4	27.7			38.1	0.0		35.2	0.0
Progression Factor	1.00	1.00		1.10	0.78			1.00	1.00		0.92	1.00
Incremental Delay, d2	10.3	12.9		7.1	0.9			2.2	5.5		0.2	0.2
Delay (s)	64.2	44.8		75.5	22.5			40.3	5.5		32.7	0.2
Level of Service	E	D		E	C			D	A		C	A
Approach Delay (s)		46.6			22.7			16.1			20.1	
Approach LOS		D			C			B			C	
<b>Intersection Summary</b>												
HCM 2000 Control Delay			28.3									C
HCM 2000 Volume to Capacity ratio			1.06									
Actuated Cycle Length (s)			130.0									24.8
Intersection Capacity Utilization			101.8%									G
Analysis Period (min)			15									

c Critical Lane Group























HCM Signalized Intersection Capacity Analysis  
10: Poulin St & Richmond Rd

Future Total (2024)  
AM Peak Hour

													
Movement	EBL	EBT	EBR	WBL	WBT	WBR	NBL	NBT	NBR	SBL	SBT	SBR	
Lane Configurations													
Traffic Volume (vph)	133	572	3	0	419	30	3	20	4	76	0	90	
Future Volume (vph)	133	572	3	0	419	30	3	20	4	76	0	90	
Ideal Flow (vphpl)	1800	1800	1800	1800	1800	1800	1800	1800	1800	1800	1800	1800	
Total Lost time (s)	6.3	6.3			6.3			6.2			6.2	6.2	
Lane Util. Factor	1.00	1.00			0.95			1.00			1.00	1.00	
Frpb, ped/bikes	1.00	1.00			1.00			0.99			1.00	0.96	
Flpb, ped/bikes	0.99	1.00			1.00			1.00			0.99	1.00	
Frt	1.00	1.00			0.99			0.98			1.00	0.85	
Flt Protected	0.95	1.00			1.00			0.99			0.95	1.00	
Satd. Flow (prot)	1623	1732			3287			1676			1452	1421	
Flt Permitted	0.49	1.00			1.00			0.97			0.74	1.00	
Satd. Flow (perm)	841	1732			3287			1632			1130	1421	
Peak-hour factor, PHF	1.00	1.00	1.00	1.00	1.00	1.00	1.00	1.00	1.00	1.00	1.00	1.00	
Adj. Flow (vph)	133	572	3	0	419	30	3	20	4	76	0	90	
RTOR Reduction (vph)	0	0	0	0	3	0	0	4	0	0	0	80	
Lane Group Flow (vph)	133	575	0	0	446	0	0	23	0	0	76	10	
Confl. Peds. (#/hr)	10		5	5		10	7		4	4		7	
Confl. Bikes (#/hr)	10		5	5		10	7		4	4		7	
Heavy Vehicles (%)	5%	5%	0%	0%	3%	15%	0%	0%	34%	18%	0%	5%	
Turn Type	Perm	NA			NA		Perm	NA		Perm	NA	Perm	
Protected Phases		2			6			8			4		
Permitted Phases	2						8			4		4	
Actuated Green, G (s)	102.9	102.9			102.9			14.6			14.6	14.6	
Effective Green, g (s)	102.9	102.9			102.9			14.6			14.6	14.6	
Actuated g/C Ratio	0.79	0.79			0.79			0.11			0.11	0.11	
Clearance Time (s)	6.3	6.3			6.3			6.2			6.2	6.2	
Vehicle Extension (s)	3.0	3.0			3.0			3.0			3.0	3.0	
Lane Grp Cap (vph)	665	1370			2601			183			126	159	
v/s Ratio Prot		c0.33			0.14								
v/s Ratio Perm	0.16							0.01			c0.07	0.01	
v/c Ratio	0.20	0.42			0.17			0.13			0.60	0.06	
Uniform Delay, d1	3.4	4.2			3.3			52.0			54.9	51.6	
Progression Factor	0.01	0.83			1.00			0.89			1.00	1.00	
Incremental Delay, d2	0.6	0.8			0.1			0.3			7.9	0.2	
Delay (s)	0.6	4.3			3.4			46.8			62.8	51.8	
Level of Service	A	A			A			D			E	D	
Approach Delay (s)		3.6			3.4			46.8			56.8		
Approach LOS		A			A			D			E		
<b>Intersection Summary</b>													
HCM 2000 Control Delay			11.0									HCM 2000 Level of Service	B
HCM 2000 Volume to Capacity ratio			0.44										
Actuated Cycle Length (s)			130.0									Sum of lost time (s)	12.5
Intersection Capacity Utilization			57.5%									ICU Level of Service	B
Analysis Period (min)			15										
c Critical Lane Group													

HCM Signalized Intersection Capacity Analysis  
 1: Croydon Ave & Richmond Rd

Future Total (2024)  
 PM Peak Hour

												
Movement	EBL	EBT	EBR	WBL	WBT	WBR	NBL	NBT	NBR	SBL	SBT	SBR
Lane Configurations												
Traffic Volume (vph)	26	480	124	62	822	18	147	99	37	15	62	20
Future Volume (vph)	26	480	124	62	822	18	147	99	37	15	62	20
Ideal Flow (vphpl)	1800	1800	1800	1800	1800	1800	1800	1800	1800	1800	1800	1800
Lane Width	3.4	3.4	3.7	3.0	3.4	3.7	3.5	3.5	3.7	3.7	4.8	3.7
Total Lost time (s)	6.4	6.4		6.4	6.4		6.1	6.1			6.1	
Lane Util. Factor	1.00	1.00		1.00	1.00		1.00	1.00			1.00	
Frbp, ped/bikes	1.00	0.99		1.00	1.00		1.00	0.97			0.99	
Flpb, ped/bikes	0.99	1.00		0.98	1.00		0.96	1.00			0.99	
Frnt	1.00	0.97		1.00	1.00		1.00	0.96			0.97	
Flt Protected	0.95	1.00		0.95	1.00		0.95	1.00			0.99	
Satd. Flow (prot)	1654	1564		1537	1649		1558	1635			1915	
Flt Permitted	0.24	1.00		0.37	1.00		0.76	1.00			0.94	
Satd. Flow (perm)	410	1564		606	1649		1242	1635			1811	
Peak-hour factor, PHF	1.00	1.00	1.00	1.00	1.00	1.00	1.00	1.00	1.00	1.00	1.00	1.00
Adj. Flow (vph)	26	480	124	62	822	18	147	99	37	15	62	20
RTOR Reduction (vph)	0	8	0	0	1	0	0	18	0	0	13	0
Lane Group Flow (vph)	26	596	0	62	839	0	147	118	0	0	84	0
Confl. Peds. (#/hr)	30		24	24		30	29		59	59		29
Heavy Vehicles (%)	0%	2%	8%	2%	2%	0%	4%	0%	4%	0%	0%	0%
Bus Blockages (#/hr)	0	10	0	0	10	0	0	0	0	0	0	0
Turn Type	Perm	NA		Perm	NA		Perm	NA		Perm	NA	
Protected Phases		2			6			8				4
Permitted Phases	2			6			8			4		
Actuated Green, G (s)	56.5	56.5		56.5	56.5		16.0	16.0			16.0	
Effective Green, g (s)	56.5	56.5		56.5	56.5		16.0	16.0			16.0	
Actuated g/C Ratio	0.66	0.66		0.66	0.66		0.19	0.19			0.19	
Clearance Time (s)	6.4	6.4		6.4	6.4		6.1	6.1			6.1	
Vehicle Extension (s)	3.0	3.0		3.0	3.0		3.0	3.0			3.0	
Lane Grp Cap (vph)	272	1039		402	1096		233	307			340	
v/s Ratio Prot		0.38			c0.51			0.07				
v/s Ratio Perm	0.06			0.10			c0.12				0.05	
v/c Ratio	0.10	0.57		0.15	0.77		0.63	0.38			0.25	
Uniform Delay, d1	5.1	7.7		5.3	9.7		31.8	30.2			29.4	
Progression Factor	1.00	1.00		1.00	1.00		1.00	1.00			1.00	
Incremental Delay, d2	0.7	2.3		0.8	5.1		5.5	0.8			0.4	
Delay (s)	5.8	10.0		6.1	14.9		37.3	31.0			29.8	
Level of Service	A	B		A	B		D	C			C	
Approach Delay (s)		9.8			14.3			34.2			29.8	
Approach LOS		A			B			C			C	
<b>Intersection Summary</b>												
HCM 2000 Control Delay			16.5				HCM 2000 Level of Service				B	
HCM 2000 Volume to Capacity ratio			0.74									
Actuated Cycle Length (s)			85.0				Sum of lost time (s)			12.5		
Intersection Capacity Utilization			85.0%				ICU Level of Service			E		
Analysis Period (min)			15									

c Critical Lane Group

# HCM Signalized Intersection Capacity Analysis

## 2: Alpine Ave/1460 Richmond & Carling Ave

Future Total (2024)  
PM Peak Hour



Movement	EBL	EBT	EBR	WBL	WBT	WBR	NBL	NBT	NBR	SBL	SBT	SBR
Lane Configurations	↗	↑↑↑		↖	↑↑↑			↕			↕	
Traffic Volume (vph)	26	1230	9	51	1975	77	19	15	30	48	17	36
Future Volume (vph)	26	1230	9	51	1975	77	19	15	30	48	17	36
Ideal Flow (vphpl)	1800	1800	1800	1800	1800	1800	1800	1800	1800	1800	1800	1800
Lane Width	3.0	3.6	3.7	3.0	3.7	3.7	3.7	4.8	3.7	3.7	3.6	3.7
Total Lost time (s)	5.9	5.9		5.9	5.9			6.7			6.7	
Lane Util. Factor	1.00	0.91		1.00	0.91			1.00			1.00	
Frbp, ped/bikes	1.00	1.00		1.00	1.00			0.98			0.98	
Flpb, ped/bikes	1.00	1.00		1.00	1.00			0.99			0.99	
Frt	1.00	1.00		1.00	0.99			0.94			0.95	
Flt Protected	0.95	1.00		0.95	1.00			0.99			0.98	
Satd. Flow (prot)	1596	4760		1548	4821			1744			1609	
Flt Permitted	0.07	1.00		0.19	1.00			0.86			0.85	
Satd. Flow (perm)	120	4760		318	4821			1516			1397	
Peak-hour factor, PHF	1.00	1.00	1.00	1.00	1.00	1.00	1.00	1.00	1.00	1.00	1.00	1.00
Adj. Flow (vph)	26	1230	9	51	1975	77	19	15	30	48	17	36
RTOR Reduction (vph)	0	0	0	0	2	0	0	27	0	0	19	0
Lane Group Flow (vph)	26	1239	0	51	2050	0	0	37	0	0	82	0
Confl. Peds. (#/hr)	40		13	13		40	32		14	14		32
Heavy Vehicles (%)	0%	2%	0%	3%	1%	0%	12%	0%	4%	3%	0%	0%
Bus Blockages (#/hr)	0	8	0	0	8	0	0	0	0	0	0	0
Turn Type	pm+pt	NA		pm+pt	NA		Perm	NA		Perm	NA	
Protected Phases	5	2		1	6			8			4	
Permitted Phases	2			6			8			4		
Actuated Green, G (s)	96.3	92.5		99.3	94.0			13.7			13.7	
Effective Green, g (s)	96.3	92.5		99.3	94.0			13.7			13.7	
Actuated g/C Ratio	0.74	0.71		0.76	0.72			0.11			0.11	
Clearance Time (s)	5.9	5.9		5.9	5.9			6.7			6.7	
Vehicle Extension (s)	3.0	3.0		3.0	3.0			3.0			3.0	
Lane Grp Cap (vph)	132	3386		293	3485			159			147	
v/s Ratio Prot	0.01	0.26		c0.01	c0.43							
v/s Ratio Perm	0.14			0.13				0.02			c0.06	
v/c Ratio	0.20	0.37		0.17	0.59			0.23			0.56	
Uniform Delay, d1	6.0	7.3		4.1	8.7			53.3			55.3	
Progression Factor	1.74	1.12		1.07	0.70			1.00			1.00	
Incremental Delay, d2	0.7	0.3		0.2	0.6			0.8			4.6	
Delay (s)	11.2	8.5		4.6	6.6			54.1			59.8	
Level of Service	B	A		A	A			D			E	
Approach Delay (s)		8.5			6.6			54.1			59.8	
Approach LOS		A			A			D			E	

### Intersection Summary

HCM 2000 Control Delay	9.7	HCM 2000 Level of Service	A
HCM 2000 Volume to Capacity ratio	0.57		
Actuated Cycle Length (s)	130.0	Sum of lost time (s)	18.5
Intersection Capacity Utilization	78.7%	ICU Level of Service	D
Analysis Period (min)	15		

c Critical Lane Group

# HCM Signalized Intersection Capacity Analysis

## 3: Carling Ave & Croydon Ave

Future Total (2024)  
PM Peak Hour

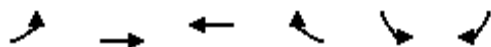

Movement	EBL	EBT	WBT	WBR	SBL	SBR
Lane Configurations	↵	↑↑↑	↑↑↑		↵↵	
Traffic Volume (vph)	95	1248	2138	150	168	106
Future Volume (vph)	95	1248	2138	150	168	106
Ideal Flow (vphpl)	1800	1800	1800	1800	1800	1800
Lane Width	2.8	3.6	3.7	3.7	3.7	3.3
Total Lost time (s)	5.9	5.9	5.9		6.3	
Lane Util. Factor	1.00	0.91	0.91		0.97	
Frpb, ped/bikes	1.00	1.00	0.99		0.98	
Flpb, ped/bikes	1.00	1.00	1.00		1.00	
Frt	1.00	1.00	0.99		0.94	
Flt Protected	0.95	1.00	1.00		0.97	
Satd. Flow (prot)	1527	4696	4696		3102	
Flt Permitted	0.04	1.00	1.00		0.97	
Satd. Flow (perm)	70	4696	4696		3102	
Peak-hour factor, PHF	1.00	1.00	1.00	1.00	1.00	1.00
Adj. Flow (vph)	95	1248	2138	150	168	106
RTOR Reduction (vph)	0	0	4	0	95	0
Lane Group Flow (vph)	95	1248	2284	0	179	0
Confl. Peds. (#/hr)	39			39	3	22
Heavy Vehicles (%)	2%	2%	1%	5%	4%	0%
Bus Blockages (#/hr)	0	19	19	0	0	0
Turn Type	pm+pt	NA	NA		Prot	
Protected Phases	5	2	6		7	
Permitted Phases	2					
Actuated Green, G (s)	104.7	104.7	89.5		13.1	
Effective Green, g (s)	104.7	104.7	89.5		13.1	
Actuated g/C Ratio	0.81	0.81	0.69		0.10	
Clearance Time (s)	5.9	5.9	5.9		6.3	
Vehicle Extension (s)	3.0	3.0	3.0		3.0	
Lane Grp Cap (vph)	160	3782	3233		312	
v/s Ratio Prot	c0.04	0.27	c0.49		c0.06	
v/s Ratio Perm	0.43					
v/c Ratio	0.59	0.33	0.71		0.57	
Uniform Delay, d1	26.7	3.4	12.3		55.8	
Progression Factor	1.76	0.38	1.00		1.00	
Incremental Delay, d2	5.6	0.2	1.3		2.5	
Delay (s)	52.5	1.5	13.6		58.3	
Level of Service	D	A	B		E	
Approach Delay (s)		5.1	13.6		58.3	
Approach LOS		A	B		E	

### Intersection Summary

HCM 2000 Control Delay	13.8	HCM 2000 Level of Service	B
HCM 2000 Volume to Capacity ratio	0.68		
Actuated Cycle Length (s)	130.0	Sum of lost time (s)	18.1
Intersection Capacity Utilization	85.9%	ICU Level of Service	E
Analysis Period (min)	15		

c Critical Lane Group

# HCM Unsignalized Intersection Capacity Analysis

## 4: Carling Ave & Forest St

Future Total (2024)  
PM Peak Hour



Movement	EBL	EBT	WBT	WBR	SBL	SBR	
Lane Configurations		↑↑↑	↑↑↑			↑	
Traffic Volume (veh/h)	0	1307	1994	36	0	108	
Future Volume (Veh/h)	0	1307	1994	36	0	108	
Sign Control		Free	Free		Stop		
Grade		0%	0%		0%		
Peak Hour Factor	1.00	1.00	1.00	1.00	1.00	1.00	
Hourly flow rate (vph)	0	1307	1994	36	0	108	
<b>Pedestrians</b>							
Lane Width (m)							
Walking Speed (m/s)							
Percent Blockage							
Right turn flare (veh)							
Median type		None	None				
Median storage (veh)							
Upstream signal (m)		55	141				
pX, platoon unblocked	0.72				0.77	0.72	
vC, conflicting volume	2030				2448	683	
vC1, stage 1 conf vol							
vC2, stage 2 conf vol							
vCu, unblocked vol	1079				981	0	
tC, single (s)	4.1				6.8	6.9	
tC, 2 stage (s)							
tF (s)	2.2				3.5	3.3	
p0 queue free %	100				100	86	
cM capacity (veh/h)	472				193	788	
Direction, Lane #	EB 1	EB 2	EB 3	WB 1	WB 2	WB 3	SB 1
Volume Total	436	436	436	798	798	435	108
Volume Left	0	0	0	0	0	0	0
Volume Right	0	0	0	0	0	36	108
cSH	1700	1700	1700	1700	1700	1700	788
Volume to Capacity	0.26	0.26	0.26	0.47	0.47	0.26	0.14
Queue Length 95th (m)	0.0	0.0	0.0	0.0	0.0	0.0	3.6
Control Delay (s)	0.0	0.0	0.0	0.0	0.0	0.0	10.3
Lane LOS							B
Approach Delay (s)	0.0			0.0			10.3
Approach LOS							B
<b>Intersection Summary</b>							
Average Delay			0.3				
Intersection Capacity Utilization			55.2%	ICU Level of Service			B
Analysis Period (min)			15				

HCM Unsignalized Intersection Capacity Analysis  
5: Croydon Ave & Bond St









Future Total (2024)  
PM Peak Hour



Movement	EBL	EBR	NBL	NBT	SBT	SBR
Lane Configurations						
Traffic Volume (veh/h)	2	18	27	218	256	15
Future Volume (Veh/h)	2	18	27	218	256	15
Sign Control	Stop			Free	Free	
Grade	0%			0%	0%	
Peak Hour Factor	1.00	1.00	1.00	1.00	1.00	1.00
Hourly flow rate (vph)	2	18	27	218	256	15
<b>Pedestrians</b>						
Lane Width (m)						
Walking Speed (m/s)						
Percent Blockage						
Right turn flare (veh)						
Median type				None	None	
Median storage veh						
Upstream signal (m)				78	181	
pX, platoon unblocked						
vC, conflicting volume	536	264	271			
vC1, stage 1 conf vol						
vC2, stage 2 conf vol						
vCu, unblocked vol	536	264	271			
tC, single (s)	6.4	6.2	4.1			
tC, 2 stage (s)						
tF (s)	3.5	3.3	2.2			
p0 queue free %	100	98	98			
cM capacity (veh/h)	499	780	1304			
<b>Direction, Lane #</b>	<b>EB 1</b>	<b>NB 1</b>	<b>SB 1</b>			
Volume Total	20	245	271			
Volume Left	2	27	0			
Volume Right	18	0	15			
cSH	738	1304	1700			
Volume to Capacity	0.03	0.02	0.16			
Queue Length 95th (m)	0.6	0.5	0.0			
Control Delay (s)	10.0	1.0	0.0			
Lane LOS	B	A				
Approach Delay (s)	10.0	1.0	0.0			
Approach LOS	B					
<b>Intersection Summary</b>						
Average Delay			0.8			
Intersection Capacity Utilization			42.2%	ICU Level of Service	A	
Analysis Period (min)			15			

HCM Unsignalized Intersection Capacity Analysis  
6: Forest St & Bond St

Future Total (2024)  
PM Peak Hour

						
Movement	WBL	WBR	NBT	NBR	SBL	SBT
Lane Configurations						
Traffic Volume (veh/h)	6	12	36	2	30	103
Future Volume (Veh/h)	6	12	36	2	30	103
Sign Control	Stop		Free		Free	
Grade	0%		0%		0%	
Peak Hour Factor	1.00	1.00	1.00	1.00	1.00	1.00
Hourly flow rate (vph)	6	12	36	2	30	103
Pedestrians						
Lane Width (m)						
Walking Speed (m/s)						
Percent Blockage						
Right turn flare (veh)						
Median type	None			None		
Median storage veh)						
Upstream signal (m)						
pX, platoon unblocked						
vC, conflicting volume	200	37			38	
vC1, stage 1 conf vol						
vC2, stage 2 conf vol						
vCu, unblocked vol	200	37			38	
tC, single (s)	6.4	6.2			4.1	
tC, 2 stage (s)						
tF (s)	3.5	3.3			2.2	
p0 queue free %	99	99			98	
cM capacity (veh/h)	778	1041			1585	
Direction, Lane #	WB 1	NB 1	SB 1			
Volume Total	18	38	133			
Volume Left	6	0	30			
Volume Right	12	2	0			
cSH	936	1700	1585			
Volume to Capacity	0.02	0.02	0.02			
Queue Length 95th (m)	0.4	0.0	0.4			
Control Delay (s)	8.9	0.0	1.8			
Lane LOS	A		A			
Approach Delay (s)	8.9	0.0	1.8			
Approach LOS	A					
Intersection Summary						
Average Delay			2.1			
Intersection Capacity Utilization			24.1%	ICU Level of Service	A	
Analysis Period (min)			15			

HCM Unsignalized Intersection Capacity Analysis  
7: Forest St & Richmond Rd

Future Total (2024)  
PM Peak Hour



Movement	EBT	EBR	WBL	WBT	NBL	NBR
Lane Configurations	→			←	←	←
Traffic Volume (veh/h)	599	15	49	940	14	30
Future Volume (Veh/h)	599	15	49	940	14	30
Sign Control	Free			Free	Stop	
Grade	0%			0%	0%	
Peak Hour Factor	1.00	1.00	1.00	1.00	1.00	1.00
Hourly flow rate (vph)	599	15	49	940	14	30
<b>Pedestrians</b>						
Lane Width (m)						
Walking Speed (m/s)						
Percent Blockage						
Right turn flare (veh)						
Median type	None			None		
Median storage (veh)						
Upstream signal (m)	279			154		
pX, platoon unblocked				0.92	0.61	0.92
vC, conflicting volume				614	1644	606
vC1, stage 1 conf vol						
vC2, stage 2 conf vol						
vCu, unblocked vol				535	1435	527
tC, single (s)				4.1	6.4	6.2
tC, 2 stage (s)						
tF (s)				2.2	3.5	3.3
p0 queue free %				95	84	94
cM capacity (veh/h)				958	87	510
<b>Direction, Lane #</b>	<b>EB 1</b>	<b>WB 1</b>	<b>NB 1</b>			
Volume Total	614	989	44			
Volume Left	0	49	14			
Volume Right	15	0	30			
cSH	1700	958	200			
Volume to Capacity	0.36	0.05	0.22			
Queue Length 95th (m)	0.0	1.2	6.2			
Control Delay (s)	0.0	1.4	28.0			
Lane LOS		A	D			
Approach Delay (s)	0.0	1.4	28.0			
Approach LOS			D			
<b>Intersection Summary</b>						
Average Delay				1.6		
Intersection Capacity Utilization				102.7%	ICU Level of Service	G
Analysis Period (min)				15		



HCM Unsignalized Intersection Capacity Analysis  
8: Bond St & 365 Forest



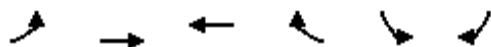





















Future Total (2024)  
PM Peak Hour



Movement	EBL	EBT	WBT	WBR	SBL	SBR
Lane Configurations		↶	↷		↶	
Traffic Volume (veh/h)	3	14	24	17	5	7
Future Volume (Veh/h)	3	14	24	17	5	7
Sign Control		Free	Free		Stop	
Grade		0%	0%		0%	
Peak Hour Factor	1.00	1.00	1.00	1.00	1.00	1.00
Hourly flow rate (vph)	3	14	24	17	5	7
Pedestrians						
Lane Width (m)						
Walking Speed (m/s)						
Percent Blockage						
Right turn flare (veh)						
Median type		None	None			
Median storage (veh)						
Upstream signal (m)						
pX, platoon unblocked						
vC, conflicting volume	41				52	32
vC1, stage 1 conf vol						
vC2, stage 2 conf vol						
vCu, unblocked vol	41				52	32
tC, single (s)	4.1				6.4	6.2
tC, 2 stage (s)						
tF (s)	2.2				3.5	3.3
p0 queue free %	100				99	99
cM capacity (veh/h)	1568				954	1041
Direction, Lane #	EB 1	WB 1	SB 1			
Volume Total	17	41	12			
Volume Left	3	0	5			
Volume Right	0	17	7			
cSH	1568	1700	1003			
Volume to Capacity	0.00	0.02	0.01			
Queue Length 95th (m)	0.0	0.0	0.3			
Control Delay (s)	1.3	0.0	8.6			
Lane LOS	A		A			
Approach Delay (s)	1.3	0.0	8.6			
Approach LOS			A			
Intersection Summary						
Average Delay			1.8			
Intersection Capacity Utilization			13.5%		ICU Level of Service	A
Analysis Period (min)			15			



















HCM Signalized Intersection Capacity Analysis  
 9: Richmond Rd & Carling Ave

Future Total (2024)  
 PM Peak Hour

													
Movement	EBL	EBT	EBR	WBL	WBT	WBR	NBL	NBT	NBR	SBL	SBT	SBR	
Lane Configurations		 			  			 			 		
Traffic Volume (vph)	252	755	3	14	1903	2	0	502	509	0	781	354	
Future Volume (vph)	252	755	3	14	1903	2	0	502	509	0	781	354	
Ideal Flow (vphpl)	1800	1800	1800	1800	1800	1800	1800	1800	1800	1800	1800	1800	
Total Lost time (s)	6.0	5.8		6.0	5.8			7.0	4.0		7.0	4.0	
Lane Util. Factor	1.00	0.95		1.00	0.91			0.95	1.00		0.95	1.00	
Frpb, ped/bikes	1.00	1.00		1.00	1.00			1.00	0.99		1.00	0.99	
Flpb, ped/bikes	1.00	1.00		1.00	1.00			1.00	1.00		1.00	1.00	
Frt	1.00	1.00		1.00	1.00			1.00	0.85		1.00	0.85	
Flt Protected	0.95	1.00		0.95	1.00			1.00	1.00		1.00	1.00	
Satd. Flow (prot)	1695	3388		988	4919			3390	1496		3357	1497	
Flt Permitted	0.95	1.00		0.95	1.00			1.00	1.00		1.00	1.00	
Satd. Flow (perm)	1695	3388		988	4919			3390	1496		3357	1497	
Peak-hour factor, PHF	1.00	1.00	1.00	1.00	1.00	1.00	1.00	1.00	1.00	1.00	1.00	1.00	
Adj. Flow (vph)	252	755	3	14	1903	2	0	502	509	0	781	354	
RTOR Reduction (vph)	0	0	0	0	0	0	0	0	0	0	0	0	
Lane Group Flow (vph)	252	758	0	14	1905	0	0	502	509	0	781	354	
Confl. Peds. (#/hr)	7		2	2		7	2		3	3		2	
Confl. Bikes (#/hr)	7		2	2		7	2		3	3		2	
Heavy Vehicles (%)	2%	2%	0%	75%	1%	0%	2%	2%	2%	2%	3%	2%	
Turn Type	Prot	NA		Prot	NA			NA	Free		NA	Free	
Protected Phases	5	2		19	6			8			4		
Permitted Phases									Free			Free	
Actuated Green, G (s)	22.3	63.6		6.0	53.3			35.6	130.0		35.6	130.0	
Effective Green, g (s)	22.3	63.6		6.0	53.3			35.6	130.0		35.6	130.0	
Actuated g/C Ratio	0.17	0.49		0.05	0.41			0.27	1.00		0.27	1.00	
Clearance Time (s)	6.0	5.8			5.8			7.0			7.0		
Vehicle Extension (s)	3.0	3.0			3.0			3.0			3.0		
Lane Grp Cap (vph)	290	1657		45	2016			928	1496		919	1497	
v/s Ratio Prot	c0.15	0.22		0.01	c0.39			0.15			c0.23		
v/s Ratio Perm									0.34			0.24	
v/c Ratio	0.87	0.46		0.31	0.94			0.54	0.34		0.85	0.24	
Uniform Delay, d1	52.4	21.8		60.0	36.9			40.2	0.0		44.7	0.0	
Progression Factor	1.00	1.00		0.91	0.65			1.00	1.00		1.00	1.00	
Incremental Delay, d2	23.0	0.9		3.4	9.7			0.6	0.6		7.4	0.4	
Delay (s)	75.4	22.8		58.0	33.5			40.9	0.6		52.1	0.4	
Level of Service	E	C		E	C			D	A		D	A	
Approach Delay (s)		35.9			33.7			20.6			36.0		
Approach LOS		D			C			C			D		
<b>Intersection Summary</b>													
HCM 2000 Control Delay			32.0									HCM 2000 Level of Service	C
HCM 2000 Volume to Capacity ratio			0.95										
Actuated Cycle Length (s)			130.0									Sum of lost time (s)	24.8
Intersection Capacity Utilization			92.7%									ICU Level of Service	F
Analysis Period (min)			15										
c Critical Lane Group													





















HCM Signalized Intersection Capacity Analysis  
10: Poulin St & Richmond Rd

Future Total (2024)  
PM Peak Hour

													
Movement	EBL	EBT	EBR	WBL	WBT	WBR	NBL	NBT	NBR	SBL	SBT	SBR	
Lane Configurations													
Traffic Volume (vph)	226	479	3	0	958	46	42	60	14	73	2	135	
Future Volume (vph)	226	479	3	0	958	46	42	60	14	73	2	135	
Ideal Flow (vphpl)	1800	1800	1800	1800	1800	1800	1800	1800	1800	1800	1800	1800	
Total Lost time (s)	6.3	6.3			6.3			6.2			6.2	6.2	
Lane Util. Factor	1.00	1.00			0.95			1.00			1.00	1.00	
Frbp, ped/bikes	1.00	1.00			1.00			0.99			1.00	0.98	
Flpb, ped/bikes	1.00	1.00			1.00			1.00			0.99	1.00	
Frt	1.00	1.00			0.99			0.98			1.00	0.85	
Flt Protected	0.95	1.00			1.00			0.98			0.95	1.00	
Satd. Flow (prot)	1729	1818			3429			1748			1722	1520	
Flt Permitted	0.18	1.00			1.00			0.85			0.66	1.00	
Satd. Flow (perm)	332	1818			3429			1511			1195	1520	
Peak-hour factor, PHF	1.00	1.00	1.00	1.00	1.00	1.00	1.00	1.00	1.00	1.00	1.00	1.00	
Adj. Flow (vph)	226	479	3	0	958	46	42	60	14	73	2	135	
RTOR Reduction (vph)	0	0	0	0	3	0	0	7	0	0	0	116	
Lane Group Flow (vph)	226	482	0	0	1001	0	0	109	0	0	75	19	
Confl. Peds. (#/hr)	6		16	16		6	2		6	6		2	
Confl. Bikes (#/hr)	6		16	16		6	2		6	6		2	
Heavy Vehicles (%)	0%	0%	0%	2%	0%	0%	0%	0%	0%	0%	0%	0%	
Turn Type	pm+pt	NA			NA		Perm	NA		Perm	NA	Perm	
Protected Phases	5	2			6			8			4		
Permitted Phases	2						8			4		4	
Actuated Green, G (s)	65.1	65.1			45.3			12.4			12.4	12.4	
Effective Green, g (s)	65.1	65.1			45.3			12.4			12.4	12.4	
Actuated g/C Ratio	0.72	0.72			0.50			0.14			0.14	0.14	
Clearance Time (s)	6.3	6.3			6.3			6.2			6.2	6.2	
Vehicle Extension (s)	3.0	3.0			3.0			3.0			3.0	3.0	
Lane Grp Cap (vph)	449	1315			1725			208			164	209	
v/s Ratio Prot	c0.08	0.27			c0.29								
v/s Ratio Perm	0.29							c0.07			0.06	0.01	
v/c Ratio	0.50	0.37			0.58			0.52			0.46	0.09	
Uniform Delay, d1	7.4	4.7			15.7			36.1			35.7	33.9	
Progression Factor	1.00	1.00			1.00			1.00			1.00	1.00	
Incremental Delay, d2	0.9	0.8			1.4			2.4			2.0	0.2	
Delay (s)	8.2	5.5			17.1			38.4			37.7	34.1	
Level of Service	A	A			B			D			D	C	
Approach Delay (s)		6.4			17.1			38.4			35.4		
Approach LOS		A			B			D			D		
<b>Intersection Summary</b>													
HCM 2000 Control Delay			16.5									HCM 2000 Level of Service	B
HCM 2000 Volume to Capacity ratio			0.56										
Actuated Cycle Length (s)			90.0									Sum of lost time (s)	18.8
Intersection Capacity Utilization			73.5%									ICU Level of Service	D
Analysis Period (min)			15										
c Critical Lane Group													

HCM Signalized Intersection Capacity Analysis  
1: Croydon Ave & Richmond Rd

Future Total (2029)  
AM Peak Hour

												
Movement	EBL	EBT	EBR	WBL	WBT	WBR	NBL	NBT	NBR	SBL	SBT	SBR
Lane Configurations												
Traffic Volume (vph)	25	632	76	20	419	19	42	32	89	31	80	42
Future Volume (vph)	25	632	76	20	419	19	42	32	89	31	80	42
Ideal Flow (vphpl)	1800	1800	1800	1800	1800	1800	1800	1800	1800	1800	1800	1800
Lane Width	3.4	3.4	3.7	3.0	3.4	3.7	3.5	3.5	3.7	3.7	4.8	3.7
Total Lost time (s)	6.4	6.4		6.4	6.4		6.1	6.1			6.1	
Lane Util. Factor	1.00	1.00		1.00	1.00		1.00	1.00			1.00	
Frbp, ped/bikes	1.00	1.00		1.00	1.00		1.00	0.94			0.98	
Flpb, ped/bikes	0.98	1.00		0.99	1.00		0.97	1.00			0.99	
Frft	1.00	0.98		1.00	0.99		1.00	0.89			0.96	
Flt Protected	0.95	1.00		0.95	1.00		0.95	1.00			0.99	
Satd. Flow (prot)	1561	1573		1583	1584		1389	1391			1849	
Flt Permitted	0.50	1.00		0.33	1.00		0.64	1.00			0.90	
Satd. Flow (perm)	824	1573		552	1584		933	1391			1676	
Peak-hour factor, PHF	1.00	1.00	1.00	1.00	1.00	1.00	1.00	1.00	1.00	1.00	1.00	1.00
Adj. Flow (vph)	25	632	76	20	419	19	42	32	89	31	80	42
RTOR Reduction (vph)	0	4	0	0	1	0	0	77	0	0	26	0
Lane Group Flow (vph)	25	704	0	20	437	0	42	44	0	0	127	0
Confl. Peds. (#/hr)	21		15	15		21	29		41	41		29
Heavy Vehicles (%)	5%	4%	15%	0%	6%	0%	18%	20%	3%	4%	0%	6%
Bus Blockages (#/hr)	0	10	0	0	10	0	0	0	0	0	0	0
Turn Type	Perm	NA		Perm	NA		Perm	NA		Perm	NA	
Protected Phases		2			6			8			4	
Permitted Phases	2			6			8			4		
Actuated Green, G (s)	48.0	48.0		48.0	48.0		9.5	9.5			9.5	
Effective Green, g (s)	48.0	48.0		48.0	48.0		9.5	9.5			9.5	
Actuated g/C Ratio	0.69	0.69		0.69	0.69		0.14	0.14			0.14	
Clearance Time (s)	6.4	6.4		6.4	6.4		6.1	6.1			6.1	
Vehicle Extension (s)	3.0	3.0		3.0	3.0		3.0	3.0			3.0	
Lane Grp Cap (vph)	565	1078		378	1086		126	188			227	
v/s Ratio Prot		c0.45			0.28			0.03				
v/s Ratio Perm	0.03			0.04			0.05				c0.08	
v/c Ratio	0.04	0.65		0.05	0.40		0.33	0.23			0.56	
Uniform Delay, d1	3.6	6.3		3.6	4.8		27.4	27.0			28.3	
Progression Factor	1.00	1.00		1.00	1.00		1.00	1.00			1.00	
Incremental Delay, d2	0.1	3.1		0.3	1.1		1.6	0.6			3.0	
Delay (s)	3.7	9.3		3.9	5.9		28.9	27.6			31.3	
Level of Service	A	A		A	A		C	C			C	
Approach Delay (s)		9.2			5.8			28.0			31.3	
Approach LOS		A			A			C			C	
<b>Intersection Summary</b>												
HCM 2000 Control Delay			12.4				HCM 2000 Level of Service				B	
HCM 2000 Volume to Capacity ratio			0.64									
Actuated Cycle Length (s)			70.0				Sum of lost time (s)			12.5		
Intersection Capacity Utilization			87.8%				ICU Level of Service			E		
Analysis Period (min)			15									

c Critical Lane Group

HCM Signalized Intersection Capacity Analysis  
2: Alpine Ave/1460 Richmond & Carling Ave

Future Total (2029)  
AM Peak Hour



Movement	EBL	EBT	EBR	WBL	WBT	WBR	NBL	NBT	NBR	SBL	SBT	SBR
Lane Configurations	↗	↑↑↑		↗	↑↑↑			↕			↕	
Traffic Volume (vph)	36	3039	7	37	1054	83	27	9	107	41	9	52
Future Volume (vph)	36	3039	7	37	1054	83	27	9	107	41	9	52
Ideal Flow (vphpl)	1800	1800	1800	1800	1800	1800	1800	1800	1800	1800	1800	1800
Lane Width	3.0	3.6	3.7	3.0	3.7	3.7	3.7	4.8	3.7	3.7	3.6	3.7
Total Lost time (s)	5.9	5.9		5.9	5.9			6.7			6.7	
Lane Util. Factor	1.00	0.91		1.00	0.91			1.00			1.00	
Frbp, ped/bikes	1.00	1.00		1.00	0.99			0.96			0.99	
Flpb, ped/bikes	0.98	1.00		1.00	1.00			1.00			0.99	
Frnt	1.00	1.00		1.00	0.99			0.90			0.93	
Flt Protected	0.95	1.00		0.95	1.00			0.99			0.98	
Satd. Flow (prot)	1508	4764		1596	4643			1674			1570	
Flt Permitted	0.24	1.00		0.04	1.00			0.89			0.62	
Satd. Flow (perm)	378	4764		68	4643			1504			994	
Peak-hour factor, PHF	1.00	1.00	1.00	1.00	1.00	1.00	1.00	1.00	1.00	1.00	1.00	1.00
Adj. Flow (vph)	36	3039	7	37	1054	83	27	9	107	41	9	52
RTOR Reduction (vph)	0	0	0	0	4	0	0	67	0	0	36	0
Lane Group Flow (vph)	36	3046	0	37	1133	0	0	76	0	0	66	0
Confl. Peds. (#/hr)	36		27	27		36	11		27	27		11
Heavy Vehicles (%)	4%	2%	0%	0%	4%	3%	10%	0%	3%	3%	0%	2%
Bus Blockages (#/hr)	0	8	0	0	8	0	0	0	0	0	0	0
Turn Type	Perm	NA		pm+pt	NA		Perm	NA		Perm	NA	
Protected Phases		2		1	6			8			4	
Permitted Phases	2			6			8			4		
Actuated Green, G (s)	93.6	93.6		104.5	104.5			12.9			12.9	
Effective Green, g (s)	93.6	93.6		104.5	104.5			12.9			12.9	
Actuated g/C Ratio	0.72	0.72		0.80	0.80			0.10			0.10	
Clearance Time (s)	5.9	5.9		5.9	5.9			6.7			6.7	
Vehicle Extension (s)	3.0	3.0		3.0	3.0			3.0			3.0	
Lane Grp Cap (vph)	272	3430		113	3732			149			98	
v/s Ratio Prot		c0.64		0.01	c0.24							
v/s Ratio Perm	0.10			0.25				0.05			c0.07	
v/c Ratio	0.13	0.89		0.33	0.30			0.51			0.67	
Uniform Delay, d1	5.6	14.1		20.0	3.3			55.6			56.5	
Progression Factor	0.55	0.48		3.23	0.83			1.00			1.00	
Incremental Delay, d2	0.5	2.2		1.6	0.2			3.0			16.7	
Delay (s)	3.7	8.9		66.2	2.9			58.5			73.2	
Level of Service	A	A		E	A			E			E	
Approach Delay (s)		8.9			4.9			58.5			73.2	
Approach LOS		A			A			E			E	

Intersection Summary

HCM 2000 Control Delay	10.9	HCM 2000 Level of Service	B
HCM 2000 Volume to Capacity ratio	0.85		
Actuated Cycle Length (s)	130.0	Sum of lost time (s)	18.5
Intersection Capacity Utilization	90.6%	ICU Level of Service	E
Analysis Period (min)	15		

c Critical Lane Group

HCM Signalized Intersection Capacity Analysis  
3: Carling Ave & Croydon Ave

Future Total (2029)  
AM Peak Hour

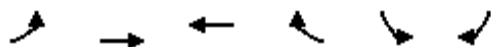

Movement	EBL	EBT	WBT	WBR	SBL	SBR
Lane Configurations	↶	↑↑↑	↑↑↑		↶↶	
Traffic Volume (vph)	120	2487	1027	112	202	31
Future Volume (vph)	120	2487	1027	112	202	31
Ideal Flow (vphpl)	1800	1800	1800	1800	1800	1800
Lane Width	2.8	3.6	3.7	3.7	3.7	3.3
Total Lost time (s)	5.9	5.9	5.9		6.3	
Lane Util. Factor	1.00	0.91	0.91		0.97	
Frpb, ped/bikes	1.00	1.00	0.99		1.00	
Flpb, ped/bikes	1.00	1.00	1.00		1.00	
Frt	1.00	1.00	0.99		0.98	
Flt Protected	0.95	1.00	1.00		0.96	
Satd. Flow (prot)	1526	4696	4586		3112	
Flt Permitted	0.21	1.00	1.00		0.96	
Satd. Flow (perm)	332	4696	4586		3112	
Peak-hour factor, PHF	1.00	1.00	1.00	1.00	1.00	1.00
Adj. Flow (vph)	120	2487	1027	112	202	31
RTOR Reduction (vph)	0	0	7	0	12	0
Lane Group Flow (vph)	120	2487	1132	0	221	0
Confl. Peds. (#/hr)	16			16	2	19
Heavy Vehicles (%)	2%	2%	3%	7%	7%	0%
Bus Blockages (#/hr)	0	19	19	0	0	0
Turn Type	pm+pt	NA	NA		Prot	
Protected Phases	5	2	6		7	
Permitted Phases	2					
Actuated Green, G (s)	103.2	103.2	89.4		14.6	
Effective Green, g (s)	103.2	103.2	89.4		14.6	
Actuated g/C Ratio	0.79	0.79	0.69		0.11	
Clearance Time (s)	5.9	5.9	5.9		6.3	
Vehicle Extension (s)	3.0	3.0	3.0		3.0	
Lane Grp Cap (vph)	336	3727	3153		349	
v/s Ratio Prot	0.02	c0.53	0.25		c0.07	
v/s Ratio Perm	0.26					
v/c Ratio	0.36	0.67	0.36		0.63	
Uniform Delay, d1	3.8	5.9	8.4		55.2	
Progression Factor	0.56	0.31	1.00		1.00	
Incremental Delay, d2	0.3	0.5	0.3		3.7	
Delay (s)	2.5	2.3	8.7		58.9	
Level of Service	A	A	A		E	
Approach Delay (s)		2.3	8.7		58.9	
Approach LOS		A	A		E	

Intersection Summary

HCM 2000 Control Delay	7.5	HCM 2000 Level of Service	A
HCM 2000 Volume to Capacity ratio	0.70		
Actuated Cycle Length (s)	130.0	Sum of lost time (s)	18.1
Intersection Capacity Utilization	77.4%	ICU Level of Service	D
Analysis Period (min)	15		

c Critical Lane Group

HCM Unsignalized Intersection Capacity Analysis  
4: Carling Ave & Forest St

Future Total (2029)  
AM Peak Hour



Movement	EBL	EBT	WBT	WBR	SBL	SBR	
Lane Configurations		↑↑↑	↑↑↑			↑	
Traffic Volume (veh/h)	0	3195	1106	27	0	68	
Future Volume (Veh/h)	0	3195	1106	27	0	68	
Sign Control		Free	Free		Stop		
Grade		0%	0%		0%		
Peak Hour Factor	1.00	1.00	1.00	1.00	1.00	1.00	
Hourly flow rate (vph)	0	3195	1106	27	0	68	
Pedestrians							
Lane Width (m)							
Walking Speed (m/s)							
Percent Blockage							
Right turn flare (veh)							
Median type		None	None				
Median storage (veh)							
Upstream signal (m)		55	141				
pX, platoon unblocked	0.92				0.33	0.92	
vC, conflicting volume	1133				2184	382	
vC1, stage 1 conf vol							
vC2, stage 2 conf vol							
vCu, unblocked vol	829				0	10	
tC, single (s)	4.1				6.8	6.9	
tC, 2 stage (s)							
tF (s)	2.2				3.5	3.3	
p0 queue free %	100				100	93	
cM capacity (veh/h)	744				342	986	
Direction, Lane #	EB 1	EB 2	EB 3	WB 1	WB 2	WB 3	SB 1
Volume Total	1065	1065	1065	442	442	248	68
Volume Left	0	0	0	0	0	0	0
Volume Right	0	0	0	0	0	27	68
cSH	1700	1700	1700	1700	1700	1700	986
Volume to Capacity	0.63	0.63	0.63	0.26	0.26	0.15	0.07
Queue Length 95th (m)	0.0	0.0	0.0	0.0	0.0	0.0	1.7
Control Delay (s)	0.0	0.0	0.0	0.0	0.0	0.0	8.9
Lane LOS							A
Approach Delay (s)	0.0			0.0			8.9
Approach LOS							A
Intersection Summary							
Average Delay			0.1				
Intersection Capacity Utilization			68.5%		ICU Level of Service		C
Analysis Period (min)			15				

HCM Unsignalized Intersection Capacity Analysis  
5: Croydon Ave & Bond St

Future Total (2029)  
AM Peak Hour











Movement	EBL	EBR	NBL	NBT	SBT	SBR
Lane Configurations						
Traffic Volume (veh/h)	2	22	18	213	210	12
Future Volume (Veh/h)	2	22	18	213	210	12
Sign Control	Stop			Free	Free	
Grade	0%			0%	0%	
Peak Hour Factor	1.00	1.00	1.00	1.00	1.00	1.00
Hourly flow rate (vph)	2	22	18	213	210	12
<b>Pedestrians</b>						
Lane Width (m)						
Walking Speed (m/s)						
Percent Blockage						
Right turn flare (veh)						
Median type				None	None	
Median storage (veh)						
Upstream signal (m)				78	181	
pX, platoon unblocked						
vC, conflicting volume	465	216	222			
vC1, stage 1 conf vol						
vC2, stage 2 conf vol						
vCu, unblocked vol	465	216	222			
tC, single (s)	6.4	6.2	4.1			
tC, 2 stage (s)						
tF (s)	3.5	3.3	2.2			
p0 queue free %	100	97	99			
cM capacity (veh/h)	552	829	1359			
<b>Direction, Lane #</b>	<b>EB 1</b>	<b>NB 1</b>	<b>SB 1</b>			
Volume Total	24	231	222			
Volume Left	2	18	0			
Volume Right	22	0	12			
cSH	796	1359	1700			
Volume to Capacity	0.03	0.01	0.13			
Queue Length 95th (m)	0.7	0.3	0.0			
Control Delay (s)	9.7	0.7	0.0			
Lane LOS	A	A				
Approach Delay (s)	9.7	0.7	0.0			
Approach LOS	A					
<b>Intersection Summary</b>						
Average Delay			0.8			
Intersection Capacity Utilization			37.5%	ICU Level of Service	A	
Analysis Period (min)			15			



HCM Unsignalized Intersection Capacity Analysis  
6: Forest St & Bond St

Future Total (2029)  
AM Peak Hour

						
Movement	WBL	WBR	NBT	NBR	SBL	SBT
Lane Configurations						
Traffic Volume (veh/h)	11	16	27	2	16	58
Future Volume (Veh/h)	11	16	27	2	16	58
Sign Control	Stop		Free		Free	
Grade	0%		0%		0%	
Peak Hour Factor	1.00	1.00	1.00	1.00	1.00	1.00
Hourly flow rate (vph)	11	16	27	2	16	58
<b>Pedestrians</b>						
Lane Width (m)						
Walking Speed (m/s)						
Percent Blockage						
Right turn flare (veh)						
Median type	None			None		
Median storage veh)						
Upstream signal (m)						
pX, platoon unblocked						
vC, conflicting volume	118	28			29	
vC1, stage 1 conf vol						
vC2, stage 2 conf vol						
vCu, unblocked vol	118	28			29	
tC, single (s)	6.4	6.2			4.1	
tC, 2 stage (s)						
tF (s)	3.5	3.3			2.2	
p0 queue free %	99	98			99	
cM capacity (veh/h)	874	1053			1597	
<b>Direction, Lane #</b>	<b>WB 1</b>	<b>NB 1</b>	<b>SB 1</b>			
Volume Total	27	29	74			
Volume Left	11	0	16			
Volume Right	16	2	0			
cSH	972	1700	1597			
Volume to Capacity	0.03	0.02	0.01			
Queue Length 95th (m)	0.7	0.0	0.2			
Control Delay (s)	8.8	0.0	1.6			
Lane LOS	A		A			
Approach Delay (s)	8.8	0.0	1.6			
Approach LOS	A					
<b>Intersection Summary</b>						
Average Delay			2.8			
Intersection Capacity Utilization			20.8%	ICU Level of Service	A	
Analysis Period (min)			15			

HCM Unsignalized Intersection Capacity Analysis  
7: Forest St & Richmond Rd

Future Total (2029)  
AM Peak Hour

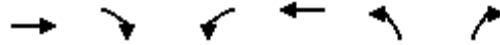

Movement	EBT	EBR	WBL	WBT	NBL	NBR
Lane Configurations	→			←	↘	↙
Traffic Volume (veh/h)	692	14	26	476	17	40
Future Volume (Veh/h)	692	14	26	476	17	40
Sign Control	Free			Free	Stop	
Grade	0%			0%	0%	
Peak Hour Factor	1.00	1.00	1.00	1.00	1.00	1.00
Hourly flow rate (vph)	692	14	26	476	17	40
<b>Pedestrians</b>						
Lane Width (m)						
Walking Speed (m/s)						
Percent Blockage						
Right turn flare (veh)						
Median type	None			None		
Median storage (veh)						
Upstream signal (m)	279			154		
pX, platoon unblocked			0.88	0.92	0.88	
vC, conflicting volume			706	1227	699	
vC1, stage 1 conf vol						
vC2, stage 2 conf vol						
vCu, unblocked vol			593	986	585	
tC, single (s)			4.1	6.4	6.2	
tC, 2 stage (s)						
tF (s)			2.2	3.5	3.3	
p0 queue free %			97	93	91	
cM capacity (veh/h)			869	247	450	
<b>Direction, Lane #</b>	<b>EB 1</b>	<b>WB 1</b>	<b>NB 1</b>			
Volume Total	706	502	57			
Volume Left	0	26	17			
Volume Right	14	0	40			
cSH	1700	869	362			
Volume to Capacity	0.42	0.03	0.16			
Queue Length 95th (m)	0.0	0.7	4.2			
Control Delay (s)	0.0	0.8	16.8			
Lane LOS			A	C		
Approach Delay (s)	0.0	0.8	16.8			
Approach LOS			C			
<b>Intersection Summary</b>						
Average Delay			1.1			
Intersection Capacity Utilization			59.1%	ICU Level of Service	B	
Analysis Period (min)			15			

HCM Unsignalized Intersection Capacity Analysis  
 8: Bond St & 365 Forest

























Future Total (2029)  
 AM Peak Hour



Movement	EBL	EBT	WBT	WBR	SBL	SBR
Lane Configurations		↶	↷		↘	↙
Traffic Volume (veh/h)	1	13	22	8	11	17
Future Volume (Veh/h)	1	13	22	8	11	17
Sign Control		Free	Free		Stop	
Grade		0%	0%		0%	
Peak Hour Factor	1.00	1.00	1.00	1.00	1.00	1.00
Hourly flow rate (vph)	1	13	22	8	11	17
Pedestrians						
Lane Width (m)						
Walking Speed (m/s)						
Percent Blockage						
Right turn flare (veh)						
Median type		None	None			
Median storage veh						
Upstream signal (m)						
pX, platoon unblocked						
vC, conflicting volume	30				41	26
vC1, stage 1 conf vol						
vC2, stage 2 conf vol						
vCu, unblocked vol	30				41	26
tC, single (s)	4.1				6.4	6.2
tC, 2 stage (s)						
tF (s)	2.2				3.5	3.3
p0 queue free %	100				99	98
cM capacity (veh/h)	1583				970	1050
Direction, Lane #	EB 1	WB 1	SB 1			
Volume Total	14	30	28			
Volume Left	1	0	11			
Volume Right	0	8	17			
cSH	1583	1700	1017			
Volume to Capacity	0.00	0.02	0.03			
Queue Length 95th (m)	0.0	0.0	0.6			
Control Delay (s)	0.5	0.0	8.6			
Lane LOS	A		A			
Approach Delay (s)	0.5	0.0	8.6			
Approach LOS			A			
Intersection Summary						
Average Delay			3.5			
Intersection Capacity Utilization		13.3%		ICU Level of Service		A
Analysis Period (min)			15			

HCM Signalized Intersection Capacity Analysis  
 9: Richmond Rd & Carling Ave























Future Total (2029)  
 AM Peak Hour

												
Movement	EBL	EBT	EBR	WBL	WBT	WBR	NBL	NBT	NBR	SBL	SBT	SBR
Lane Configurations		 			  			 			 	
Traffic Volume (vph)	180	1712	0	5	1114	0	0	600	1369	0	346	217
Future Volume (vph)	180	1712	0	5	1114	0	0	600	1369	0	346	217
Ideal Flow (vphpl)	1800	1800	1800	1800	1800	1800	1800	1800	1800	1800	1800	1800
Total Lost time (s)	6.0	5.8		6.0	5.8			7.0	4.0		7.0	4.0
Lane Util. Factor	1.00	0.95		1.00	0.91			0.95	1.00		0.95	1.00
Frpb, ped/bikes	1.00	1.00		1.00	1.00			1.00	0.99		1.00	0.98
Flpb, ped/bikes	1.00	1.00		1.00	1.00			1.00	1.00		1.00	1.00
Frt	1.00	1.00		1.00	1.00			1.00	0.85		1.00	0.85
Flt Protected	0.95	1.00		0.95	1.00			1.00	1.00		1.00	1.00
Satd. Flow (prot)	1679	3369		864	4772			3325	1495		3325	1479
Flt Permitted	0.95	1.00		0.95	1.00			1.00	1.00		1.00	1.00
Satd. Flow (perm)	1679	3369		864	4772			3325	1495		3325	1479
Peak-hour factor, PHF	1.00	1.00	1.00	1.00	1.00	1.00	1.00	1.00	1.00	1.00	1.00	1.00
Adj. Flow (vph)	180	1712	0	5	1114	0	0	600	1369	0	346	217
RTOR Reduction (vph)	0	0	0	0	0	0	0	0	0	0	0	0
Lane Group Flow (vph)	180	1712	0	5	1114	0	0	600	1369	0	346	217
Confl. Peds. (#/hr)	8		7	7		8	6		4	4		6
Confl. Bikes (#/hr)	8		7	7		8	6		4	4		6
Heavy Vehicles (%)	3%	1%	0%	100%	3%	0%	0%	4%	2%	0%	4%	3%
Bus Blockages (#/hr)	0	8	0	0	8	0	0	0	0	0	0	0
Turn Type	Prot	NA		Prot	NA			NA	Free		NA	Free
Protected Phases	5	2		19	6			8			4	
Permitted Phases									Free			Free
Actuated Green, G (s)	18.5	63.2		3.0	53.7			39.0	130.0		39.0	130.0
Effective Green, g (s)	18.5	63.2		3.0	53.7			39.0	130.0		39.0	130.0
Actuated g/C Ratio	0.14	0.49		0.02	0.41			0.30	1.00		0.30	1.00
Clearance Time (s)	6.0	5.8			5.8			7.0			7.0	
Vehicle Extension (s)	3.0	3.0			3.0			3.0			3.0	
Lane Grp Cap (vph)	238	1637		19	1971			997	1495		997	1479
v/s Ratio Prot	0.11	c0.51		0.01	0.23			0.18			0.10	
v/s Ratio Perm									c0.92			0.15
v/c Ratio	0.76	1.05		0.26	0.57			0.60	0.92		0.35	0.15
Uniform Delay, d1	53.6	33.4		62.4	29.2			38.9	0.0		35.6	0.0
Progression Factor	1.00	1.00		1.04	0.78			1.00	1.00		0.92	1.00
Incremental Delay, d2	12.8	35.3		7.1	1.2			2.7	10.3		0.2	0.2
Delay (s)	66.4	68.7		72.1	24.1			41.6	10.3		32.8	0.2
Level of Service	E	E		E	C			D	B		C	A
Approach Delay (s)		68.5			24.3			19.8			20.2	
Approach LOS		E			C			B			C	
<b>Intersection Summary</b>												
HCM 2000 Control Delay			37.4									D
HCM 2000 Volume to Capacity ratio			1.16									
Actuated Cycle Length (s)			130.0									24.8
Intersection Capacity Utilization			106.5%									G
Analysis Period (min)			15									

c Critical Lane Group





















HCM Signalized Intersection Capacity Analysis  
10: Poulin St & Richmond Rd

Future Total (2029)  
AM Peak Hour

													
Movement	EBL	EBT	EBR	WBL	WBT	WBR	NBL	NBT	NBR	SBL	SBT	SBR	
Lane Configurations					 			 			 	 	
Traffic Volume (vph)	147	631	3	0	462	33	3	22	4	83	0	99	
Future Volume (vph)	147	631	3	0	462	33	3	22	4	83	0	99	
Ideal Flow (vphpl)	1800	1800	1800	1800	1800	1800	1800	1800	1800	1800	1800	1800	
Total Lost time (s)	6.3	6.3			6.3			6.2			6.2	6.2	
Lane Util. Factor	1.00	1.00			0.95			1.00			1.00	1.00	
Frbp, ped/bikes	1.00	1.00			1.00			0.99			1.00	0.97	
Flpb, ped/bikes	0.99	1.00			1.00			1.00			0.99	1.00	
Frt	1.00	1.00			0.99			0.98			1.00	0.85	
Flt Protected	0.95	1.00			1.00			0.99			0.95	1.00	
Satd. Flow (prot)	1624	1732			3287			1686			1452	1422	
Flt Permitted	0.47	1.00			1.00			0.97			0.74	1.00	
Satd. Flow (perm)	805	1732			3287			1645			1128	1422	
Peak-hour factor, PHF	1.00	1.00	1.00	1.00	1.00	1.00	1.00	1.00	1.00	1.00	1.00	1.00	
Adj. Flow (vph)	147	631	3	0	462	33	3	22	4	83	0	99	
RTOR Reduction (vph)	0	0	0	0	3	0	0	4	0	0	0	87	
Lane Group Flow (vph)	147	634	0	0	492	0	0	25	0	0	83	12	
Confl. Peds. (#/hr)	10		5	5		10	7		4	4		7	
Confl. Bikes (#/hr)	10		5	5		10	7		4	4		7	
Heavy Vehicles (%)	5%	5%	0%	0%	3%	15%	0%	0%	34%	18%	0%	5%	
Turn Type	Perm	NA			NA		Perm	NA		Perm	NA	Perm	
Protected Phases		2			6			8			4		
Permitted Phases	2						8		4			4	
Actuated Green, G (s)	102.2	102.2			102.2			15.3			15.3	15.3	
Effective Green, g (s)	102.2	102.2			102.2			15.3			15.3	15.3	
Actuated g/C Ratio	0.79	0.79			0.79			0.12			0.12	0.12	
Clearance Time (s)	6.3	6.3			6.3			6.2			6.2	6.2	
Vehicle Extension (s)	3.0	3.0			3.0			3.0			3.0	3.0	
Lane Grp Cap (vph)	632	1361			2584			193			132	167	
v/s Ratio Prot		c0.37			0.15								
v/s Ratio Perm	0.18							0.02			c0.07	0.01	
v/c Ratio	0.23	0.47			0.19			0.13			0.63	0.07	
Uniform Delay, d1	3.6	4.7			3.5			51.4			54.6	51.0	
Progression Factor	0.03	0.86			1.00			0.98			1.00	1.00	
Incremental Delay, d2	0.7	0.9			0.2			0.3			9.0	0.2	
Delay (s)	0.8	5.0			3.7			50.4			63.7	51.2	
Level of Service	A	A			A			D			E	D	
Approach Delay (s)		4.2			3.7			50.4			56.9		
Approach LOS		A			A			D			E		
<b>Intersection Summary</b>													
HCM 2000 Control Delay			11.4									HCM 2000 Level of Service	B
HCM 2000 Volume to Capacity ratio			0.49										
Actuated Cycle Length (s)			130.0									Sum of lost time (s)	12.5
Intersection Capacity Utilization			59.5%									ICU Level of Service	B
Analysis Period (min)			15										
c Critical Lane Group													

HCM Signalized Intersection Capacity Analysis  
 1: Croydon Ave & Richmond Rd

Future Total (2029)  
 PM Peak Hour

												
Movement	EBL	EBT	EBR	WBL	WBT	WBR	NBL	NBT	NBR	SBL	SBT	SBR
Lane Configurations												
Traffic Volume (vph)	29	528	133	68	907	20	160	109	41	16	69	22
Future Volume (vph)	29	528	133	68	907	20	160	109	41	16	69	22
Ideal Flow (vphpl)	1800	1800	1800	1800	1800	1800	1800	1800	1800	1800	1800	1800
Lane Width	3.4	3.4	3.7	3.0	3.4	3.7	3.5	3.5	3.7	3.7	4.8	3.7
Total Lost time (s)	6.4	6.4		6.4	6.4		6.1	6.1			6.1	
Lane Util. Factor	1.00	1.00		1.00	1.00		1.00	1.00			1.00	
Frbp, ped/bikes	1.00	0.99		1.00	1.00		1.00	0.97			0.99	
Flpb, ped/bikes	1.00	1.00		0.99	1.00		0.96	1.00			0.99	
Frnt	1.00	0.97		1.00	1.00		1.00	0.96			0.97	
Flt Protected	0.95	1.00		0.95	1.00		0.95	1.00			0.99	
Satd. Flow (prot)	1672	1565		1541	1649		1559	1634			1917	
Flt Permitted	0.18	1.00		0.33	1.00		0.73	1.00			0.94	
Satd. Flow (perm)	313	1565		542	1649		1201	1634			1813	
Peak-hour factor, PHF	1.00	1.00	1.00	1.00	1.00	1.00	1.00	1.00	1.00	1.00	1.00	1.00
Adj. Flow (vph)	29	528	133	68	907	20	160	109	41	16	69	22
RTOR Reduction (vph)	0	8	0	0	1	0	0	18	0	0	13	0
Lane Group Flow (vph)	29	653	0	68	926	0	160	132	0	0	94	0
Confl. Peds. (#/hr)	30		24	24		30	29		59	59		29
Heavy Vehicles (%)	0%	2%	8%	2%	2%	0%	4%	0%	4%	0%	0%	0%
Bus Blockages (#/hr)	0	10	0	0	10	0	0	0	0	0	0	0
Turn Type	Perm	NA		Perm	NA		Perm	NA		Perm	NA	
Protected Phases		2			6			8				4
Permitted Phases	2			6			8			4		
Actuated Green, G (s)	55.5	55.5		55.5	55.5		17.0	17.0			17.0	
Effective Green, g (s)	55.5	55.5		55.5	55.5		17.0	17.0			17.0	
Actuated g/C Ratio	0.65	0.65		0.65	0.65		0.20	0.20			0.20	
Clearance Time (s)	6.4	6.4		6.4	6.4		6.1	6.1			6.1	
Vehicle Extension (s)	3.0	3.0		3.0	3.0		3.0	3.0			3.0	
Lane Grp Cap (vph)	204	1021		353	1076		240	326			362	
v/s Ratio Prot		0.42			c0.56			0.08				
v/s Ratio Perm	0.09			0.13			c0.13				0.05	
v/c Ratio	0.14	0.64		0.19	0.86		0.67	0.40			0.26	
Uniform Delay, d1	5.6	8.8		5.9	11.7		31.4	29.6			28.7	
Progression Factor	1.00	1.00		1.00	1.00		1.00	1.00			1.00	
Incremental Delay, d2	1.5	3.1		1.2	9.0		6.8	0.8			0.4	
Delay (s)	7.1	11.9		7.1	20.7		38.2	30.4			29.1	
Level of Service	A	B		A	C		D	C			C	
Approach Delay (s)		11.7			19.8			34.4			29.1	
Approach LOS		B			B			C			C	
<b>Intersection Summary</b>												
HCM 2000 Control Delay			19.8				HCM 2000 Level of Service				B	
HCM 2000 Volume to Capacity ratio			0.81									
Actuated Cycle Length (s)			85.0				Sum of lost time (s)				12.5	
Intersection Capacity Utilization			90.8%				ICU Level of Service				E	
Analysis Period (min)			15									

c Critical Lane Group

HCM Signalized Intersection Capacity Analysis  
2: Alpine Ave/1460 Richmond & Carling Ave

Future Total (2029)  
PM Peak Hour



Movement	EBL	EBT	EBR	WBL	WBT	WBR	NBL	NBT	NBR	SBL	SBT	SBR
Lane Configurations	↗	↑↑↑		↗	↑↑↑			↕			↕	
Traffic Volume (vph)	29	1352	10	57	2178	85	21	16	33	53	19	40
Future Volume (vph)	29	1352	10	57	2178	85	21	16	33	53	19	40
Ideal Flow (vphpl)	1800	1800	1800	1800	1800	1800	1800	1800	1800	1800	1800	1800
Lane Width	3.0	3.6	3.7	3.0	3.7	3.7	3.7	4.8	3.7	3.7	3.6	3.7
Total Lost time (s)	5.9	5.9		5.9	5.9			6.7			6.7	
Lane Util. Factor	1.00	0.91		1.00	0.91			1.00			1.00	
Frpb, ped/bikes	1.00	1.00		1.00	1.00			0.98			0.98	
Flpb, ped/bikes	1.00	1.00		1.00	1.00			0.99			0.99	
Fr <sub>t</sub>	1.00	1.00		1.00	0.99			0.94			0.95	
Fl <sub>t</sub> Protected	0.95	1.00		0.95	1.00			0.99			0.98	
Satd. Flow (prot)	1596	4760		1549	4821			1742			1609	
Fl <sub>t</sub> Permitted	0.05	1.00		0.17	1.00			0.85			0.84	
Satd. Flow (perm)	88	4760		271	4821			1498			1380	
Peak-hour factor, PHF	1.00	1.00	1.00	1.00	1.00	1.00	1.00	1.00	1.00	1.00	1.00	1.00
Adj. Flow (vph)	29	1352	10	57	2178	85	21	16	33	53	19	40
RTOR Reduction (vph)	0	0	0	0	2	0	0	29	0	0	19	0
Lane Group Flow (vph)	29	1362	0	57	2261	0	0	41	0	0	93	0
Confl. Peds. (#/hr)	40		13	13		40	32		14	14		32
Heavy Vehicles (%)	0%	2%	0%	3%	1%	0%	12%	0%	4%	3%	0%	0%
Bus Blockages (#/hr)	0	8	0	0	8	0	0	0	0	0	0	0
Turn Type	pm+pt	NA		pm+pt	NA		Perm	NA		Perm	NA	
Protected Phases	5	2		1	6			8			4	
Permitted Phases	2			6			8			4		
Actuated Green, G (s)	95.1	91.3		98.5	93.0			14.7			14.7	
Effective Green, g (s)	95.1	91.3		98.5	93.0			14.7			14.7	
Actuated g/C Ratio	0.73	0.70		0.76	0.72			0.11			0.11	
Clearance Time (s)	5.9	5.9		5.9	5.9			6.7			6.7	
Vehicle Extension (s)	3.0	3.0		3.0	3.0			3.0			3.0	
Lane Grp Cap (vph)	108	3342		259	3448			169			156	
v/s Ratio Prot	0.01	0.29		c0.01	c0.47							
v/s Ratio Perm	0.19			0.16				0.03			c0.07	
v/c Ratio	0.27	0.41		0.22	0.66			0.24			0.60	
Uniform Delay, d <sub>1</sub>	7.7	8.1		4.5	9.9			52.6			54.8	
Progression Factor	2.42	1.17		1.22	0.75			1.00			1.00	
Incremental Delay, d <sub>2</sub>	1.3	0.3		0.3	0.7			0.7			6.1	
Delay (s)	19.9	9.8		5.8	8.0			53.3			60.9	
Level of Service	B	A		A	A			D			E	
Approach Delay (s)		10.0			8.0			53.3			60.9	
Approach LOS		A			A			D			E	

Intersection Summary

HCM 2000 Control Delay	11.0	HCM 2000 Level of Service	B
HCM 2000 Volume to Capacity ratio	0.64		
Actuated Cycle Length (s)	130.0	Sum of lost time (s)	18.5
Intersection Capacity Utilization	84.3%	ICU Level of Service	E
Analysis Period (min)	15		

c Critical Lane Group

HCM Signalized Intersection Capacity Analysis  
3: Carling Ave & Croydon Ave

Future Total (2029)  
PM Peak Hour

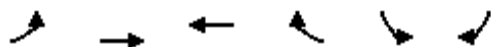

Movement	EBL	EBT	WBT	WBR	SBL	SBR
Lane Configurations	↙	↑↑↑	↑↑↑		↙↘	
Traffic Volume (vph)	103	1374	2360	165	185	115
Future Volume (vph)	103	1374	2360	165	185	115
Ideal Flow (vphpl)	1800	1800	1800	1800	1800	1800
Lane Width	2.8	3.6	3.7	3.7	3.7	3.3
Total Lost time (s)	5.9	5.9	5.9		6.3	
Lane Util. Factor	1.00	0.91	0.91		0.97	
Frpb, ped/bikes	1.00	1.00	0.99		0.99	
Flpb, ped/bikes	1.00	1.00	1.00		1.00	
Frt	1.00	1.00	0.99		0.94	
Flt Protected	0.95	1.00	1.00		0.97	
Satd. Flow (prot)	1527	4696	4696		3103	
Flt Permitted	0.04	1.00	1.00		0.97	
Satd. Flow (perm)	69	4696	4696		3103	
Peak-hour factor, PHF	1.00	1.00	1.00	1.00	1.00	1.00
Adj. Flow (vph)	103	1374	2360	165	185	115
RTOR Reduction (vph)	0	0	4	0	94	0
Lane Group Flow (vph)	103	1374	2521	0	206	0
Confl. Peds. (#/hr)	39			39	3	22
Heavy Vehicles (%)	2%	2%	1%	5%	4%	0%
Bus Blockages (#/hr)	0	19	19	0	0	0
Turn Type	pm+pt	NA	NA		Prot	
Protected Phases	5	2	6		7	
Permitted Phases	2					
Actuated Green, G (s)	103.7	103.7	87.8		14.1	
Effective Green, g (s)	103.7	103.7	87.8		14.1	
Actuated g/C Ratio	0.80	0.80	0.68		0.11	
Clearance Time (s)	5.9	5.9	5.9		6.3	
Vehicle Extension (s)	3.0	3.0	3.0		3.0	
Lane Grp Cap (vph)	167	3745	3171		336	
v/s Ratio Prot	c0.05	0.29	c0.54		c0.07	
v/s Ratio Perm	0.45					
v/c Ratio	0.62	0.37	0.79		0.61	
Uniform Delay, d1	31.9	3.8	14.8		55.4	
Progression Factor	1.74	0.35	1.00		1.00	
Incremental Delay, d2	6.2	0.3	2.2		3.3	
Delay (s)	61.7	1.6	16.9		58.7	
Level of Service	E	A	B		E	
Approach Delay (s)		5.8	16.9		58.7	
Approach LOS		A	B		E	

Intersection Summary

HCM 2000 Control Delay	16.0	HCM 2000 Level of Service	B
HCM 2000 Volume to Capacity ratio	0.76		
Actuated Cycle Length (s)	130.0	Sum of lost time (s)	18.1
Intersection Capacity Utilization	91.7%	ICU Level of Service	F
Analysis Period (min)	15		

c Critical Lane Group



HCM Unsignalized Intersection Capacity Analysis  
4: Carling Ave & Forest St

Future Total (2029)  
PM Peak Hour

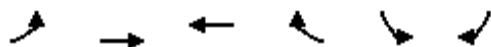

Movement	EBL	EBT	WBT	WBR	SBL	SBR	
Lane Configurations		↑↑↑	↑↑↑			↗	
Traffic Volume (veh/h)	0	1437	2200	40	0	119	
Future Volume (Veh/h)	0	1437	2200	40	0	119	
Sign Control		Free	Free		Stop		
Grade		0%	0%		0%		
Peak Hour Factor	1.00	1.00	1.00	1.00	1.00	1.00	
Hourly flow rate (vph)	0	1437	2200	40	0	119	
<b>Pedestrians</b>							
Lane Width (m)							
Walking Speed (m/s)							
Percent Blockage							
Right turn flare (veh)							
Median type		None	None				
Median storage (veh)							
Upstream signal (m)		55	141				
pX, platoon unblocked	0.64				0.70	0.64	
vC, conflicting volume	2240				2699	753	
vC1, stage 1 conf vol							
vC2, stage 2 conf vol							
vCu, unblocked vol	957				786	0	
tC, single (s)	4.1				6.8	6.9	
tC, 2 stage (s)							
tF (s)	2.2				3.5	3.3	
p0 queue free %	100				100	83	
cM capacity (veh/h)	464				232	696	
Direction, Lane #	EB 1	EB 2	EB 3	WB 1	WB 2	WB 3	SB 1
Volume Total	479	479	479	880	880	480	119
Volume Left	0	0	0	0	0	0	0
Volume Right	0	0	0	0	0	40	119
cSH	1700	1700	1700	1700	1700	1700	696
Volume to Capacity	0.28	0.28	0.28	0.52	0.52	0.28	0.17
Queue Length 95th (m)	0.0	0.0	0.0	0.0	0.0	0.0	4.7
Control Delay (s)	0.0	0.0	0.0	0.0	0.0	0.0	11.2
Lane LOS							B
Approach Delay (s)	0.0			0.0			11.2
Approach LOS							B
<b>Intersection Summary</b>							
Average Delay			0.4				
Intersection Capacity Utilization			60.3%	ICU Level of Service		B	
Analysis Period (min)			15				

HCM Unsignalized Intersection Capacity Analysis  
5: Croydon Ave & Bond St









Future Total (2029)  
PM Peak Hour



Movement	EBL	EBR	NBL	NBT	SBT	SBR
Lane Configurations						
Traffic Volume (veh/h)	2	19	28	239	281	16
Future Volume (Veh/h)	2	19	28	239	281	16
Sign Control	Stop			Free	Free	
Grade	0%			0%	0%	
Peak Hour Factor	1.00	1.00	1.00	1.00	1.00	1.00
Hourly flow rate (vph)	2	19	28	239	281	16
<b>Pedestrians</b>						
Lane Width (m)						
Walking Speed (m/s)						
Percent Blockage						
Right turn flare (veh)						
Median type				None	None	
Median storage veh						
Upstream signal (m)				78	181	
pX, platoon unblocked						
vC, conflicting volume	584	289	297			
vC1, stage 1 conf vol						
vC2, stage 2 conf vol						
vCu, unblocked vol	584	289	297			
tC, single (s)	6.4	6.2	4.1			
tC, 2 stage (s)						
tF (s)	3.5	3.3	2.2			
p0 queue free %	100	97	98			
cM capacity (veh/h)	467	755	1276			
<b>Direction, Lane #</b>	<b>EB 1</b>	<b>NB 1</b>	<b>SB 1</b>			
Volume Total	21	267	297			
Volume Left	2	28	0			
Volume Right	19	0	16			
cSH	713	1276	1700			
Volume to Capacity	0.03	0.02	0.17			
Queue Length 95th (m)	0.7	0.5	0.0			
Control Delay (s)	10.2	1.0	0.0			
Lane LOS	B	A				
Approach Delay (s)	10.2	1.0	0.0			
Approach LOS	B					
<b>Intersection Summary</b>						
Average Delay				0.8		
Intersection Capacity Utilization				44.9%	ICU Level of Service	A
Analysis Period (min)				15		

HCM Unsignalized Intersection Capacity Analysis  
6: Forest St & Bond St

Future Total (2029)  
PM Peak Hour

						
Movement	WBL	WBR	NBT	NBR	SBL	SBT
Lane Configurations						
Traffic Volume (veh/h)	6	13	40	2	33	114
Future Volume (Veh/h)	6	13	40	2	33	114
Sign Control	Stop		Free		Free	
Grade	0%		0%		0%	
Peak Hour Factor	1.00	1.00	1.00	1.00	1.00	1.00
Hourly flow rate (vph)	6	13	40	2	33	114
Pedestrians						
Lane Width (m)						
Walking Speed (m/s)						
Percent Blockage						
Right turn flare (veh)						
Median type	None			None		
Median storage veh						
Upstream signal (m)						
pX, platoon unblocked						
vC, conflicting volume	221	41			42	
vC1, stage 1 conf vol						
vC2, stage 2 conf vol						
vCu, unblocked vol	221	41			42	
tC, single (s)	6.4	6.2			4.1	
tC, 2 stage (s)						
tF (s)	3.5	3.3			2.2	
p0 queue free %	99	99			98	
cM capacity (veh/h)	756	1036			1580	
Direction, Lane #	WB 1	NB 1	SB 1			
Volume Total	19	42	147			
Volume Left	6	0	33			
Volume Right	13	2	0			
cSH	927	1700	1580			
Volume to Capacity	0.02	0.02	0.02			
Queue Length 95th (m)	0.5	0.0	0.5			
Control Delay (s)	9.0	0.0	1.8			
Lane LOS	A		A			
Approach Delay (s)	9.0	0.0	1.8			
Approach LOS	A					
Intersection Summary						
Average Delay			2.1			
Intersection Capacity Utilization			24.9%	ICU Level of Service		A
Analysis Period (min)			15			

HCM Unsignalized Intersection Capacity Analysis  
7: Forest St & Richmond Rd

Future Total (2029)  
PM Peak Hour

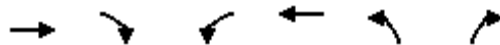

Movement	EBT	EBR	WBL	WBT	NBL	NBR
Lane Configurations	→	↘	←	→	←	↘
Traffic Volume (veh/h)	657	16	54	1036	15	33
Future Volume (Veh/h)	657	16	54	1036	15	33
Sign Control	Free			Free	Stop	
Grade	0%			0%	0%	
Peak Hour Factor	1.00	1.00	1.00	1.00	1.00	1.00
Hourly flow rate (vph)	657	16	54	1036	15	33
<b>Pedestrians</b>						
Lane Width (m)						
Walking Speed (m/s)						
Percent Blockage						
Right turn flare (veh)						
Median type	None			None		
Median storage (veh)						
Upstream signal (m)	279			154		
pX, platoon unblocked			0.89		0.50	0.89
vC, conflicting volume			673		1809	665
vC1, stage 1 conf vol						
vC2, stage 2 conf vol						
vCu, unblocked vol			571		1624	562
tC, single (s)			4.1		6.4	6.2
tC, 2 stage (s)						
tF (s)			2.2		3.5	3.3
p0 queue free %			94		72	93
cM capacity (veh/h)			901		54	472
<b>Direction, Lane #</b>	<b>EB 1</b>	<b>WB 1</b>	<b>NB 1</b>			
Volume Total	673	1090	48			
Volume Left	0	54	15			
Volume Right	16	0	33			
cSH	1700	901	137			
Volume to Capacity	0.40	0.06	0.35			
Queue Length 95th (m)	0.0	1.5	10.9			
Control Delay (s)	0.0	1.8	44.7			
Lane LOS		A	E			
Approach Delay (s)	0.0	1.8	44.7			
Approach LOS			E			
<b>Intersection Summary</b>						
Average Delay			2.3			
Intersection Capacity Utilization			111.6%	ICU Level of Service	H	
Analysis Period (min)			15			

HCM Unsignalized Intersection Capacity Analysis  
8: Bond St & 365 Forest



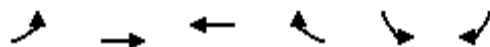





















Future Total (2029)  
PM Peak Hour



Movement	EBL	EBT	WBT	WBR	SBL	SBR
Lane Configurations		↔	↔		↔	
Traffic Volume (veh/h)	3	15	26	17	5	7
Future Volume (Veh/h)	3	15	26	17	5	7
Sign Control		Free	Free		Stop	
Grade		0%	0%		0%	
Peak Hour Factor	1.00	1.00	1.00	1.00	1.00	1.00
Hourly flow rate (vph)	3	15	26	17	5	7
Pedestrians						
Lane Width (m)						
Walking Speed (m/s)						
Percent Blockage						
Right turn flare (veh)						
Median type		None	None			
Median storage (veh)						
Upstream signal (m)						
pX, platoon unblocked						
vC, conflicting volume	43				56	34
vC1, stage 1 conf vol						
vC2, stage 2 conf vol						
vCu, unblocked vol	43				56	34
tC, single (s)	4.1				6.4	6.2
tC, 2 stage (s)						
tF (s)	2.2				3.5	3.3
p0 queue free %	100				99	99
cM capacity (veh/h)	1566				950	1039
Direction, Lane #	EB 1	WB 1	SB 1			
Volume Total	18	43	12			
Volume Left	3	0	5			
Volume Right	0	17	7			
cSH	1566	1700	1000			
Volume to Capacity	0.00	0.03	0.01			
Queue Length 95th (m)	0.0	0.0	0.3			
Control Delay (s)	1.2	0.0	8.6			
Lane LOS	A		A			
Approach Delay (s)	1.2	0.0	8.6			
Approach LOS			A			
Intersection Summary						
Average Delay			1.7			
Intersection Capacity Utilization			13.5%		ICU Level of Service	A
Analysis Period (min)			15			





















HCM Signalized Intersection Capacity Analysis  
 9: Richmond Rd & Carling Ave

Future Total (2029)  
 PM Peak Hour

													
Movement	EBL	EBT	EBR	WBL	WBT	WBR	NBL	NBT	NBR	SBL	SBT	SBR	
Lane Configurations		 			  			 			 		
Traffic Volume (vph)	278	828	3	15	2099	2	0	549	562	0	861	391	
Future Volume (vph)	278	828	3	15	2099	2	0	549	562	0	861	391	
Ideal Flow (vphpl)	1800	1800	1800	1800	1800	1800	1800	1800	1800	1800	1800	1800	
Total Lost time (s)	6.0	5.8		6.0	5.8			7.0	4.0		7.0	4.0	
Lane Util. Factor	1.00	0.95		1.00	0.91			0.95	1.00		0.95	1.00	
Frpb, ped/bikes	1.00	1.00		1.00	1.00			1.00	0.99		1.00	0.99	
Flpb, ped/bikes	1.00	1.00		1.00	1.00			1.00	1.00		1.00	1.00	
Frt	1.00	1.00		1.00	1.00			1.00	0.85		1.00	0.85	
Flt Protected	0.95	1.00		0.95	1.00			1.00	1.00		1.00	1.00	
Satd. Flow (prot)	1695	3388		988	4919			3390	1496		3357	1497	
Flt Permitted	0.95	1.00		0.95	1.00			1.00	1.00		1.00	1.00	
Satd. Flow (perm)	1695	3388		988	4919			3390	1496		3357	1497	
Peak-hour factor, PHF	1.00	1.00	1.00	1.00	1.00	1.00	1.00	1.00	1.00	1.00	1.00	1.00	
Adj. Flow (vph)	278	828	3	15	2099	2	0	549	562	0	861	391	
RTOR Reduction (vph)	0	0	0	0	0	0	0	0	0	0	0	0	
Lane Group Flow (vph)	278	831	0	15	2101	0	0	549	562	0	861	391	
Confl. Peds. (#/hr)	7		2	2		7	2		3	3		2	
Confl. Bikes (#/hr)	7		2	2		7	2		3	3		2	
Heavy Vehicles (%)	2%	2%	0%	75%	1%	0%	2%	2%	2%	2%	3%	2%	
Turn Type	Prot	NA		Prot	NA			NA	Free		NA	Free	
Protected Phases	5	2		19	6			8			4		
Permitted Phases									Free			Free	
Actuated Green, G (s)	23.1	61.8		6.0	50.7			37.4	130.0		37.4	130.0	
Effective Green, g (s)	23.1	61.8		6.0	50.7			37.4	130.0		37.4	130.0	
Actuated g/C Ratio	0.18	0.48		0.05	0.39			0.29	1.00		0.29	1.00	
Clearance Time (s)	6.0	5.8			5.8			7.0			7.0		
Vehicle Extension (s)	3.0	3.0			3.0			3.0			3.0		
Lane Grp Cap (vph)	301	1610		45	1918			975	1496		965	1497	
v/s Ratio Prot	c0.16	0.25		0.02	c0.43			0.16			c0.26		
v/s Ratio Perm									0.38			0.26	
v/c Ratio	0.92	0.52		0.33	1.10			0.56	0.38		0.89	0.26	
Uniform Delay, d1	52.6	23.7		60.1	39.6			39.4	0.0		44.4	0.0	
Progression Factor	1.00	1.00		0.93	0.65			1.00	1.00		1.00	1.00	
Incremental Delay, d2	32.4	1.2		3.6	50.6			0.7	0.7		10.5	0.4	
Delay (s)	85.0	24.9		59.5	76.3			40.1	0.7		54.8	0.4	
Level of Service	F	C		E	E			D	A		D	A	
Approach Delay (s)		40.0			76.2			20.2			37.8		
Approach LOS		D			E			C			D		
<b>Intersection Summary</b>													
HCM 2000 Control Delay			49.3									HCM 2000 Level of Service	D
HCM 2000 Volume to Capacity ratio			1.05										
Actuated Cycle Length (s)			130.0									Sum of lost time (s)	24.8
Intersection Capacity Utilization			100.4%									ICU Level of Service	G
Analysis Period (min)			15										
c Critical Lane Group													

HCM Signalized Intersection Capacity Analysis  
10: Poulin St & Richmond Rd

Future Total (2029)  
PM Peak Hour

													
Movement	EBL	EBT	EBR	WBL	WBT	WBR	NBL	NBT	NBR	SBL	SBT	SBR	
Lane Configurations													
Traffic Volume (vph)	249	529	3	0	1056	50	47	66	15	81	2	149	
Future Volume (vph)	249	529	3	0	1056	50	47	66	15	81	2	149	
Ideal Flow (vphpl)	1800	1800	1800	1800	1800	1800	1800	1800	1800	1800	1800	1800	
Total Lost time (s)	6.3	6.3			6.3			6.2			6.2	6.2	
Lane Util. Factor	1.00	1.00			0.95			1.00			1.00	1.00	
Frpb, ped/bikes	1.00	1.00			1.00			0.99			1.00	0.98	
Flpb, ped/bikes	1.00	1.00			1.00			1.00			0.99	1.00	
Frt	1.00	1.00			0.99			0.98			1.00	0.85	
Flt Protected	0.95	1.00			1.00			0.98			0.95	1.00	
Satd. Flow (prot)	1729	1818			3429			1748			1722	1521	
Flt Permitted	0.14	1.00			1.00			0.84			0.63	1.00	
Satd. Flow (perm)	247	1818			3429			1503			1146	1521	
Peak-hour factor, PHF	1.00	1.00	1.00	1.00	1.00	1.00	1.00	1.00	1.00	1.00	1.00	1.00	
Adj. Flow (vph)	249	529	3	0	1056	50	47	66	15	81	2	149	
RTOR Reduction (vph)	0	0	0	0	3	0	0	7	0	0	0	127	
Lane Group Flow (vph)	249	532	0	0	1103	0	0	121	0	0	83	22	
Confl. Peds. (#/hr)	6		16	16		6	2		6	6		2	
Confl. Bikes (#/hr)	6		16	16		6	2		6	6		2	
Heavy Vehicles (%)	0%	0%	0%	2%	0%	0%	0%	0%	0%	0%	0%	0%	
Turn Type	pm+pt	NA			NA		Perm	NA		Perm	NA	Perm	
Protected Phases	5	2			6			8			4		
Permitted Phases	2						8			4		4	
Actuated Green, G (s)	64.5	64.5			42.1			13.0			13.0	13.0	
Effective Green, g (s)	64.5	64.5			42.1			13.0			13.0	13.0	
Actuated g/C Ratio	0.72	0.72			0.47			0.14			0.14	0.14	
Clearance Time (s)	6.3	6.3			6.3			6.2			6.2	6.2	
Vehicle Extension (s)	3.0	3.0			3.0			3.0			3.0	3.0	
Lane Grp Cap (vph)	442	1302			1604			217			165	219	
v/s Ratio Prot	c0.10	0.29			c0.32								
v/s Ratio Perm	0.30							c0.08			0.07	0.01	
v/c Ratio	0.56	0.41			0.69			0.56			0.50	0.10	
Uniform Delay, d1	10.5	5.1			18.8			35.8			35.5	33.4	
Progression Factor	1.00	1.00			1.00			1.00			1.00	1.00	
Incremental Delay, d2	1.6	1.0			2.4			3.1			2.4	0.2	
Delay (s)	12.2	6.1			21.2			38.9			37.9	33.6	
Level of Service	B	A			C			D			D	C	
Approach Delay (s)		8.0			21.2			38.9			35.2		
Approach LOS		A			C			D			D		
<b>Intersection Summary</b>													
HCM 2000 Control Delay			19.1									HCM 2000 Level of Service	B
HCM 2000 Volume to Capacity ratio			0.64										
Actuated Cycle Length (s)			90.0									Sum of lost time (s)	18.8
Intersection Capacity Utilization			78.4%									ICU Level of Service	D
Analysis Period (min)			15										
c Critical Lane Group													

## Appendix H – Left Turn Lane Warrant Analysis



**Exhibit 9A-2**

Existing AM  
Existing PM

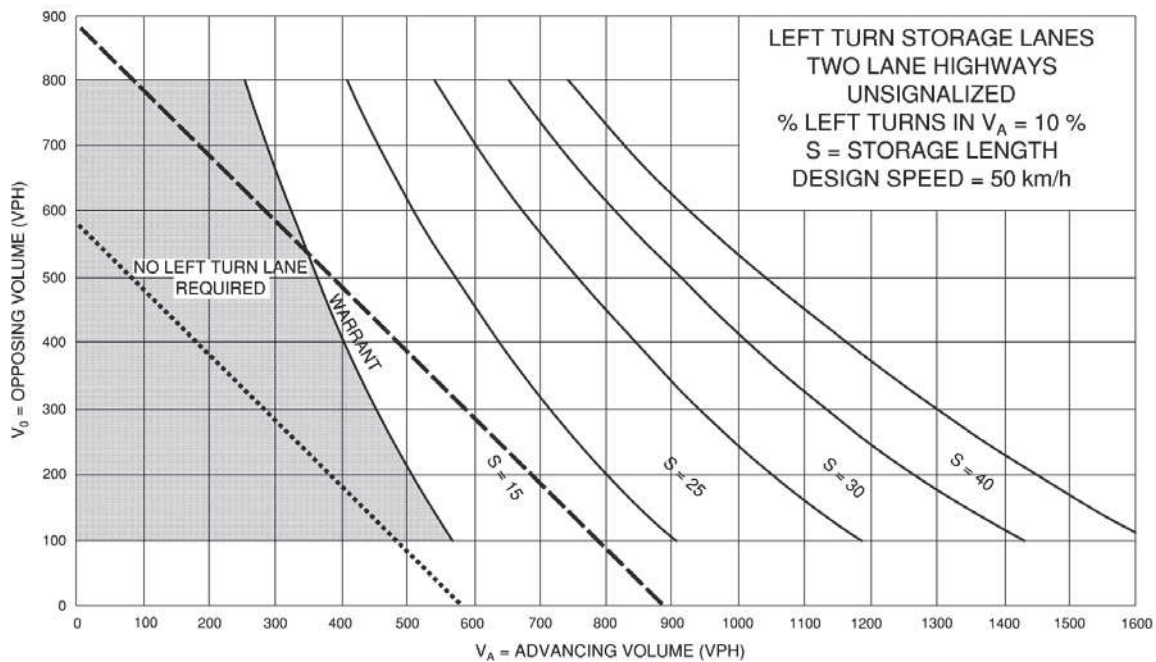
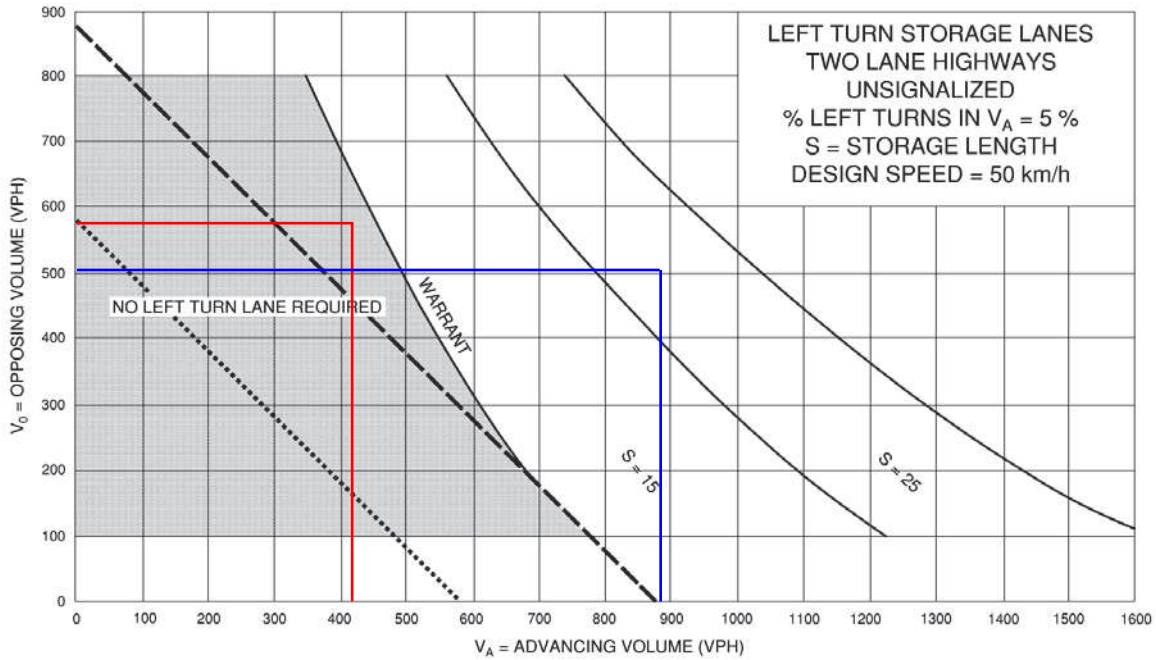

**Exhibit 9A-2**

2029 BG AM  
2029 BG PM

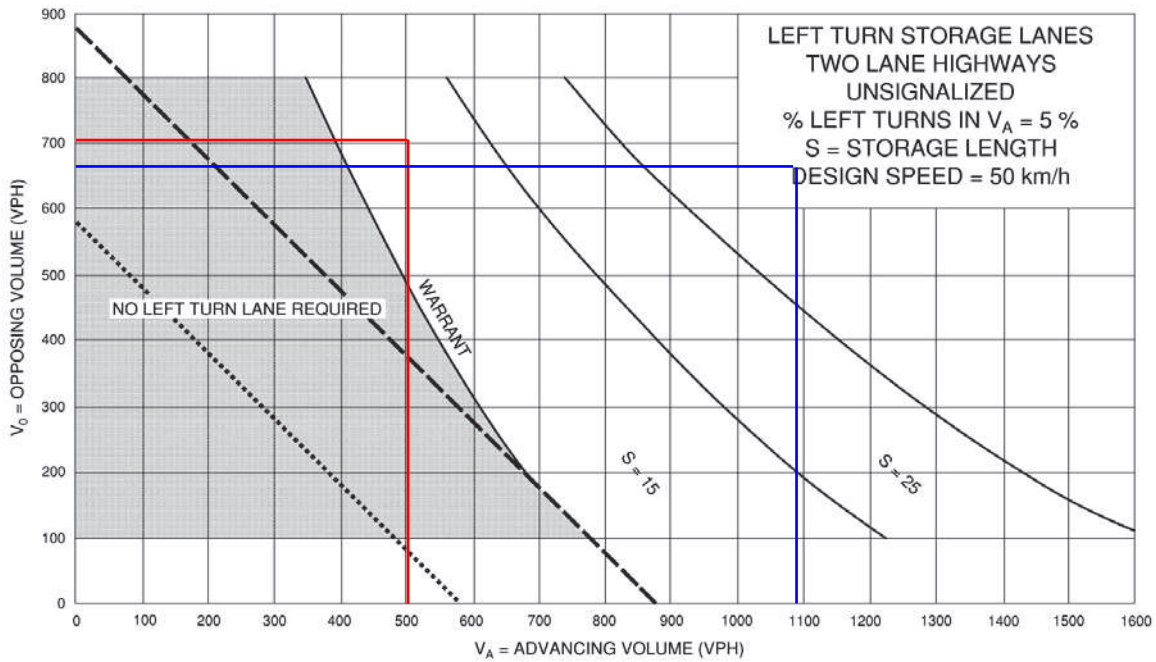

--- TRAFFIC SIGNALS MAY BE WARRANTED IN RURAL AREAS OR URBAN AREAS WITH RESTRICTED FLOW



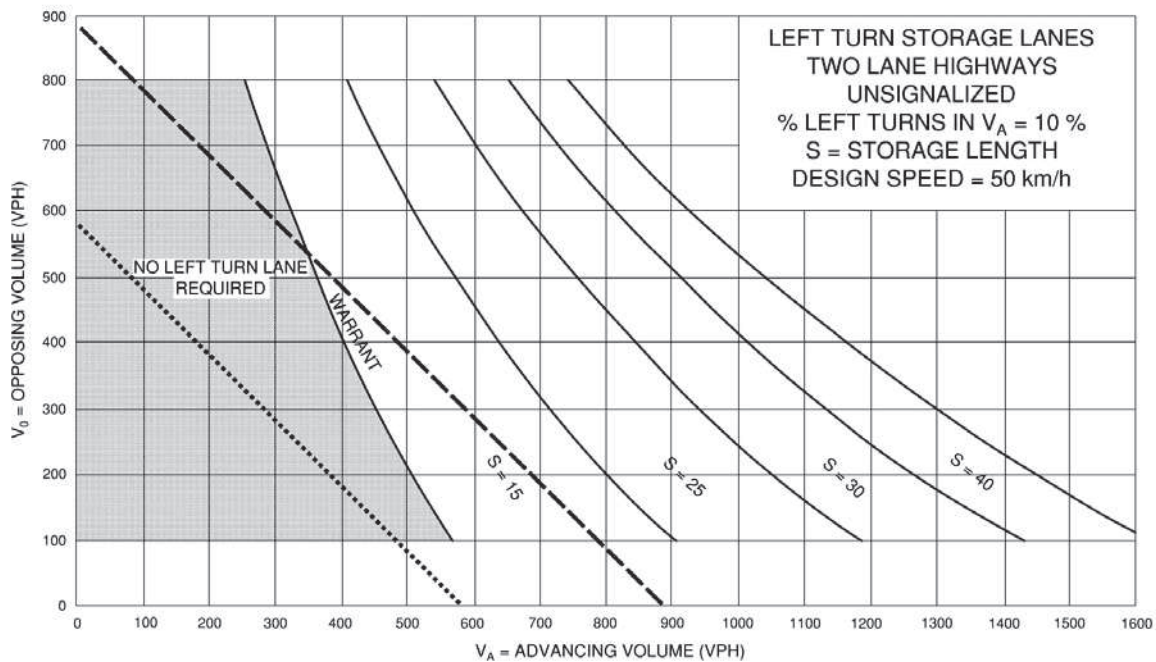

















..... TRAFFIC SIGNALS MAY BE WARRANTED IN "FREE FLOW" URBAN AREAS



## Appendix I – Future Total & Mitigated Level of Service Outputs

HCM Signalized Intersection Capacity Analysis  
1: Croydon Ave & Richmond Rd

Future Total (2029) Mitigated  
AM Peak Hour

												
Movement	EBL	EBT	EBR	WBL	WBT	WBR	NBL	NBT	NBR	SBL	SBT	SBR
Lane Configurations												
Traffic Volume (vph)	25	632	76	20	419	19	42	32	89	31	80	42
Future Volume (vph)	25	632	76	20	419	19	42	32	89	31	80	42
Ideal Flow (vphpl)	1800	1800	1800	1800	1800	1800	1800	1800	1800	1800	1800	1800
Lane Width	3.4	3.4	3.7	3.0	3.4	3.7	3.5	3.5	3.7	3.7	4.8	3.7
Total Lost time (s)	6.4	6.4		6.4	6.4		6.1	6.1			6.1	
Lane Util. Factor	1.00	1.00		1.00	1.00		1.00	1.00			1.00	
Frbp, ped/bikes	1.00	1.00		1.00	1.00		1.00	0.94			0.98	
Flpb, ped/bikes	0.98	1.00		0.99	1.00		0.97	1.00			0.99	
Frtp	1.00	0.98		1.00	0.99		1.00	0.89			0.96	
Fltp Protected	0.95	1.00		0.95	1.00		0.95	1.00			0.99	
Satd. Flow (prot)	1561	1573		1583	1584		1389	1391			1849	
Fltp Permitted	0.50	1.00		0.33	1.00		0.64	1.00			0.90	
Satd. Flow (perm)	824	1573		552	1584		933	1391			1676	
Peak-hour factor, PHF	1.00	1.00	1.00	1.00	1.00	1.00	1.00	1.00	1.00	1.00	1.00	1.00
Adj. Flow (vph)	25	632	76	20	419	19	42	32	89	31	80	42
RTOR Reduction (vph)	0	4	0	0	1	0	0	77	0	0	26	0
Lane Group Flow (vph)	25	704	0	20	437	0	42	44	0	0	127	0
Confl. Peds. (#/hr)	21		15	15		21	29		41	41		29
Heavy Vehicles (%)	5%	4%	15%	0%	6%	0%	18%	20%	3%	4%	0%	6%
Bus Blockages (#/hr)	0	10	0	0	10	0	0	0	0	0	0	0
Turn Type	Perm	NA		Perm	NA		Perm	NA		Perm	NA	
Protected Phases		2			6			8				4
Permitted Phases	2			6			8			4		
Actuated Green, G (s)	48.0	48.0		48.0	48.0		9.5	9.5			9.5	
Effective Green, g (s)	48.0	48.0		48.0	48.0		9.5	9.5			9.5	
Actuated g/C Ratio	0.69	0.69		0.69	0.69		0.14	0.14			0.14	
Clearance Time (s)	6.4	6.4		6.4	6.4		6.1	6.1			6.1	
Vehicle Extension (s)	3.0	3.0		3.0	3.0		3.0	3.0			3.0	
Lane Grp Cap (vph)	565	1078		378	1086		126	188			227	
v/s Ratio Prot		c0.45			0.28			0.03				
v/s Ratio Perm	0.03			0.04			0.05				c0.08	
v/c Ratio	0.04	0.65		0.05	0.40		0.33	0.23			0.56	
Uniform Delay, d1	3.6	6.3		3.6	4.8		27.4	27.0			28.3	
Progression Factor	1.00	1.00		1.00	1.00		1.00	1.00			1.00	
Incremental Delay, d2	0.1	3.1		0.3	1.1		1.6	0.6			3.0	
Delay (s)	3.7	9.3		3.9	5.9		28.9	27.6			31.3	
Level of Service	A	A		A	A		C	C			C	
Approach Delay (s)		9.2			5.8			28.0			31.3	
Approach LOS		A			A			C			C	
<b>Intersection Summary</b>												
HCM 2000 Control Delay			12.4				HCM 2000 Level of Service				B	
HCM 2000 Volume to Capacity ratio			0.64									
Actuated Cycle Length (s)			70.0				Sum of lost time (s)			12.5		
Intersection Capacity Utilization			87.8%				ICU Level of Service			E		
Analysis Period (min)			15									

c Critical Lane Group

Timing Report, Sorted By Phase  
1: Croydon Ave & Richmond Rd

Future Total (2029) Mitigated  
AM Peak Hour



Phase Number	2	4	6	8
Movement	EBTL	SBTL	WBTL	NBTL
Lead/Lag				
Lead-Lag Optimize				
Recall Mode	C-Max	None	C-Max	None
Maximum Split (s)	38.9	31.1	38.9	31.1
Maximum Split (%)	55.6%	44.4%	55.6%	44.4%
Minimum Split (s)	26.4	31.1	26.4	31.1
Yellow Time (s)	3.3	3.3	3.3	3.3
All-Red Time (s)	3.1	2.8	3.1	2.8
Minimum Initial (s)	10	10	10	10
Vehicle Extension (s)	3	3	3	3
Minimum Gap (s)	3	3	3	3
Time Before Reduce (s)	0	0	0	0
Time To Reduce (s)	0	0	0	0
Walk Time (s)	7	7	7	7
Flash Dont Walk (s)	13	18	13	18
Dual Entry	Yes	Yes	Yes	Yes
Inhibit Max	Yes	Yes	Yes	Yes
Start Time (s)	40	8.9	40	8.9
End Time (s)	8.9	40	8.9	40
Yield/Force Off (s)	2.5	33.9	2.5	33.9
Yield/Force Off 170(s)	59.5	15.9	59.5	15.9
Local Start Time (s)	0	38.9	0	38.9
Local Yield (s)	32.5	63.9	32.5	63.9
Local Yield 170(s)	19.5	45.9	19.5	45.9

Intersection Summary	
Cycle Length	70
Control Type	Actuated-Coordinated
Natural Cycle	75
Offset: 40 (57%), Referenced to phase 2:EBTL and 6:WBTL, Start of Green	

Splits and Phases: 1: Croydon Ave & Richmond Rd

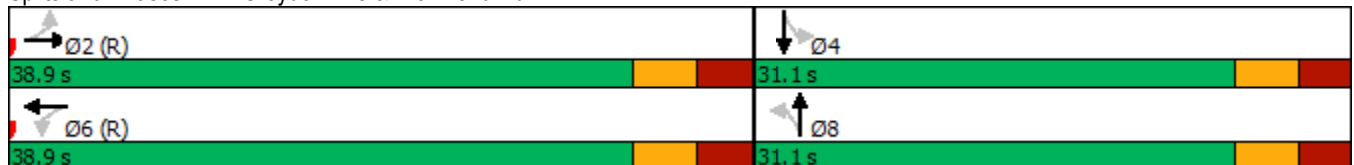

HCM Signalized Intersection Capacity Analysis  
2: Alpine Ave/1460 Richmond & Carling Ave

Future Total (2029) Mitigated  
AM Peak Hour



Movement	EBL	EBT	EBR	WBL	WBT	WBR	NBL	NBT	NBR	SBL	SBT	SBR
Lane Configurations	↙	↑↑↑		↙	↑↑↑			↕			↕	
Traffic Volume (vph)	36	3039	7	37	1054	83	27	9	107	41	9	52
Future Volume (vph)	36	3039	7	37	1054	83	27	9	107	41	9	52
Ideal Flow (vphpl)	1800	1800	1800	1800	1800	1800	1800	1800	1800	1800	1800	1800
Lane Width	3.0	3.6	3.7	3.0	3.7	3.7	3.7	4.8	3.7	3.7	3.6	3.7
Total Lost time (s)	5.9	5.9		5.9	5.9			6.7			6.7	
Lane Util. Factor	1.00	0.91		1.00	0.91			1.00			1.00	
Frbp, ped/bikes	1.00	1.00		1.00	0.99			0.96			0.99	
Flpb, ped/bikes	1.00	1.00		1.00	1.00			1.00			0.99	
Frt	1.00	1.00		1.00	0.99			0.90			0.93	
Flt Protected	0.95	1.00		0.95	1.00			0.99			0.98	
Satd. Flow (prot)	1530	4764		1596	4643			1674			1570	
Flt Permitted	0.23	1.00		0.04	1.00			0.89			0.62	
Satd. Flow (perm)	369	4764		71	4643			1504			994	
Peak-hour factor, PHF	1.00	1.00	1.00	1.00	1.00	1.00	1.00	1.00	1.00	1.00	1.00	1.00
Adj. Flow (vph)	36	3039	7	37	1054	83	27	9	107	41	9	52
RTOR Reduction (vph)	0	0	0	0	4	0	0	67	0	0	36	0
Lane Group Flow (vph)	36	3046	0	37	1133	0	0	76	0	0	66	0
Confl. Peds. (#/hr)	36		27	27		36	11		27	27		11
Heavy Vehicles (%)	4%	2%	0%	0%	4%	3%	10%	0%	3%	3%	0%	2%
Bus Blockages (#/hr)	0	8	0	0	8	0	0	0	0	0	0	0
Turn Type	pm+pt	NA		pm+pt	NA		Perm	NA		Perm	NA	
Protected Phases	5	2		1	6			8			4	
Permitted Phases	2			6			8			4		
Actuated Green, G (s)	97.4	93.5		99.8	94.7			12.9			12.9	
Effective Green, g (s)	97.4	93.5		99.8	94.7			12.9			12.9	
Actuated g/C Ratio	0.75	0.72		0.77	0.73			0.10			0.10	
Clearance Time (s)	5.9	5.9		5.9	5.9			6.7			6.7	
Vehicle Extension (s)	3.0	3.0		3.0	3.0			3.0			3.0	
Lane Grp Cap (vph)	311	3426		114	3382			149			98	
v/s Ratio Prot	0.00	c0.64		c0.01	0.24							
v/s Ratio Perm	0.08			0.24				0.05			c0.07	
v/c Ratio	0.12	0.89		0.32	0.33			0.51			0.67	
Uniform Delay, d1	4.2	14.2		18.4	6.3			55.6			56.5	
Progression Factor	0.62	0.48		2.86	0.71			1.00			1.00	
Incremental Delay, d2	0.1	2.2		1.6	0.3			3.0			16.7	
Delay (s)	2.7	9.0		54.3	4.7			58.5			73.2	
Level of Service	A	A		D	A			E			E	
Approach Delay (s)		8.9			6.3			58.5			73.2	
Approach LOS		A			A			E			E	

Intersection Summary

HCM 2000 Control Delay	11.2	HCM 2000 Level of Service	B
HCM 2000 Volume to Capacity ratio	0.84		
Actuated Cycle Length (s)	130.0	Sum of lost time (s)	18.5
Intersection Capacity Utilization	90.6%	ICU Level of Service	E
Analysis Period (min)	15		

c Critical Lane Group

Timing Report, Sorted By Phase  
 2: Alpine Ave/1460 Richmond & Carling Ave

Future Total (2029) Mitigated  
 AM Peak Hour



Phase Number	1	2	4	5	6	8
Movement	WBL	EBTL	SBTL	EBL	WBTL	NBTL
Lead/Lag	Lead	Lag		Lead	Lag	
Lead-Lag Optimize						
Recall Mode	None	C-Max	None	None	C-Max	None
Maximum Split (s)	11	76	43	11	76	43
Maximum Split (%)	8.5%	58.5%	33.1%	8.5%	58.5%	33.1%
Minimum Split (s)	10.9	33.9	42.7	10.9	33.9	32.7
Yellow Time (s)	3.7	3.7	3.3	3.7	3.7	3.3
All-Red Time (s)	2.2	2.2	3.4	2.2	2.2	3.4
Minimum Initial (s)	5	10	10	5	10	10
Vehicle Extension (s)	3	3	3	3	3	3
Minimum Gap (s)	3	3	3	3	3	3
Time Before Reduce (s)	0	0	0	0	0	0
Time To Reduce (s)	0	0	0	0	0	0
Walk Time (s)		16	7		16	7
Flash Dont Walk (s)		12	29		12	19
Dual Entry	No	Yes	Yes	No	Yes	Yes
Inhibit Max	Yes	Yes	Yes	Yes	Yes	Yes
Start Time (s)	29	40	116	29	40	116
End Time (s)	40	116	29	40	116	29
Yield/Force Off (s)	34.1	110.1	22.3	34.1	110.1	22.3
Yield/Force Off 170(s)	34.1	98.1	123.3	34.1	98.1	3.3
Local Start Time (s)	119	0	76	119	0	76
Local Yield (s)	124.1	70.1	112.3	124.1	70.1	112.3
Local Yield 170(s)	124.1	58.1	83.3	124.1	58.1	93.3

Intersection Summary

Cycle Length	130
Control Type	Actuated-Coordinated
Natural Cycle	150
Offset: 40 (31%), Referenced to phase 2:EBTL and 6:WBTL, Start of Green	

Splits and Phases: 2: Alpine Ave/1460 Richmond & Carling Ave

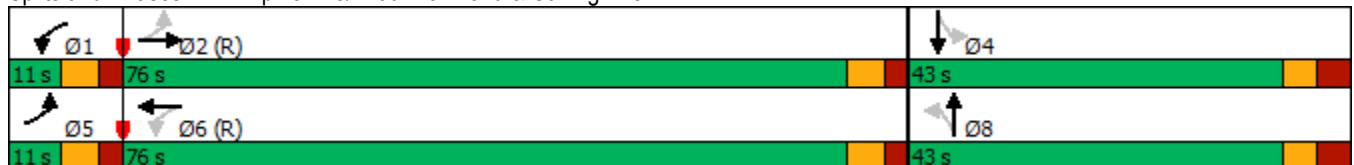

HCM Signalized Intersection Capacity Analysis  
3: Carling Ave & Croydon Ave

Future Total (2029) Mitigated  
AM Peak Hour

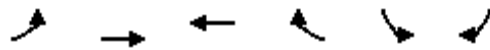

Movement	EBL	EBT	WBT	WBR	SBL	SBR
Lane Configurations	↵	↑↑↑	↑↑↑		↵↵	
Traffic Volume (vph)	120	2487	1027	112	202	31
Future Volume (vph)	120	2487	1027	112	202	31
Ideal Flow (vphpl)	1800	1800	1800	1800	1800	1800
Lane Width	2.8	3.6	3.7	3.7	3.7	3.3
Total Lost time (s)	5.9	5.9	5.9		6.3	
Lane Util. Factor	1.00	0.91	0.91		0.97	
Frpb, ped/bikes	1.00	1.00	0.99		1.00	
Flpb, ped/bikes	1.00	1.00	1.00		1.00	
Frt	1.00	1.00	0.99		0.98	
Flt Protected	0.95	1.00	1.00		0.96	
Satd. Flow (prot)	1527	4696	4586		3112	
Flt Permitted	0.95	1.00	1.00		0.96	
Satd. Flow (perm)	1527	4696	4586		3112	
Peak-hour factor, PHF	1.00	1.00	1.00	1.00	1.00	1.00
Adj. Flow (vph)	120	2487	1027	112	202	31
RTOR Reduction (vph)	0	0	10	0	12	0
Lane Group Flow (vph)	120	2487	1129	0	221	0
Confl. Peds. (#/hr)	16			16	2	19
Heavy Vehicles (%)	2%	2%	3%	7%	7%	0%
Bus Blockages (#/hr)	0	19	19	0	0	0
Turn Type	Prot	NA	NA		Prot	
Protected Phases	5	2	6		7	
Permitted Phases						
Actuated Green, G (s)	21.0	103.2	76.3		14.6	
Effective Green, g (s)	21.0	103.2	76.3		14.6	
Actuated g/C Ratio	0.16	0.79	0.59		0.11	
Clearance Time (s)	5.9	5.9	5.9		6.3	
Vehicle Extension (s)	3.0	3.0	3.0		3.0	
Lane Grp Cap (vph)	246	3727	2691		349	
v/s Ratio Prot	0.08	c0.53	0.25		c0.07	
v/s Ratio Perm						
v/c Ratio	0.49	0.67	0.42		0.63	
Uniform Delay, d1	49.6	5.9	14.7		55.2	
Progression Factor	1.34	0.31	1.00		1.00	
Incremental Delay, d2	0.8	0.5	0.5		3.7	
Delay (s)	67.1	2.3	15.2		58.9	
Level of Service	E	A	B		E	
Approach Delay (s)		5.3	15.2		58.9	
Approach LOS		A	B		E	

Intersection Summary			
HCM 2000 Control Delay	11.3	HCM 2000 Level of Service	B
HCM 2000 Volume to Capacity ratio	0.70		
Actuated Cycle Length (s)	130.0	Sum of lost time (s)	18.1
Intersection Capacity Utilization	77.4%	ICU Level of Service	D
Analysis Period (min)	15		

c Critical Lane Group



Timing Report, Sorted By Phase  
3: Carling Ave & Croydon Ave

Future Total (2029) Mitigated  
AM Peak Hour



Phase Number	2	5	6	7
Movement	EBT	EBL	WBT	SBL
Lead/Lag		Lead	Lag	
Lead-Lag Optimize				
Recall Mode	C-Max	None	C-Max	None
Maximum Split (s)	92	14	78	38
Maximum Split (%)	70.8%	10.8%	60.0%	29.2%
Minimum Split (s)	23.9	10.9	28.9	37.3
Yellow Time (s)	3.7	3.7	3.7	3.3
All-Red Time (s)	2.2	2.2	2.2	3
Minimum Initial (s)	10	5	10	10
Vehicle Extension (s)	3	3	3	3
Minimum Gap (s)	3	3	3	3
Time Before Reduce (s)	0	0	0	0
Time To Reduce (s)	0	0	0	0
Walk Time (s)			7	21
Flash Dont Walk (s)			16	10
Dual Entry	Yes	No	Yes	No
Inhibit Max	Yes	Yes	Yes	Yes
Start Time (s)	31	31	45	123
End Time (s)	123	45	123	31
Yield/Force Off (s)	117.1	39.1	117.1	24.7
Yield/Force Off 170(s)	117.1	39.1	101.1	14.7
Local Start Time (s)	116	116	0	78
Local Yield (s)	72.1	124.1	72.1	109.7
Local Yield 170(s)	72.1	124.1	56.1	99.7

Intersection Summary

Cycle Length	130
Control Type	Actuated-Coordinated
Natural Cycle	90
Offset: 45 (35%), Referenced to phase 2:EBT and 6:WBT, Start of Green	

Splits and Phases: 3: Carling Ave & Croydon Ave



HCM Unsignalized Intersection Capacity Analysis  
4: Carling Ave & Forest St

Future Total (2029) Mitigated  
AM Peak Hour

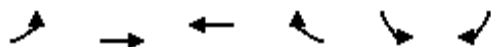

Movement	EBL	EBT	WBT	WBR	SBL	SBR	
Lane Configurations		↑↑↑	↑↑↑			↑	
Traffic Volume (veh/h)	0	3195	1106	27	0	68	
Future Volume (Veh/h)	0	3195	1106	27	0	68	
Sign Control		Free	Free		Stop		
Grade		0%	0%		0%		
Peak Hour Factor	1.00	1.00	1.00	1.00	1.00	1.00	
Hourly flow rate (vph)	0	3195	1106	27	0	68	
Pedestrians							
Lane Width (m)							
Walking Speed (m/s)							
Percent Blockage							
Right turn flare (veh)							
Median type		None	None				
Median storage (veh)							
Upstream signal (m)		55	141				
pX, platoon unblocked	0.88				0.35	0.88	
vC, conflicting volume	1133				2184	382	
vC1, stage 1 conf vol							
vC2, stage 2 conf vol							
vCu, unblocked vol	689				0	0	
tC, single (s)	4.1				6.8	6.9	
tC, 2 stage (s)							
tF (s)	2.2				3.5	3.3	
p0 queue free %	100				100	93	
cM capacity (veh/h)	808				360	964	
Direction, Lane #	EB 1	EB 2	EB 3	WB 1	WB 2	WB 3	SB 1
Volume Total	1065	1065	1065	442	442	248	68
Volume Left	0	0	0	0	0	0	0
Volume Right	0	0	0	0	0	27	68
cSH	1700	1700	1700	1700	1700	1700	964
Volume to Capacity	0.63	0.63	0.63	0.26	0.26	0.15	0.07
Queue Length 95th (m)	0.0	0.0	0.0	0.0	0.0	0.0	1.7
Control Delay (s)	0.0	0.0	0.0	0.0	0.0	0.0	9.0
Lane LOS							A
Approach Delay (s)	0.0			0.0			9.0
Approach LOS							A
Intersection Summary							
Average Delay			0.1				
Intersection Capacity Utilization			68.5%		ICU Level of Service		C
Analysis Period (min)			15				

HCM Unsignalized Intersection Capacity Analysis  
5: Croydon Ave & Bond St









Future Total (2029) Mitigated  
AM Peak Hour



Movement	EBL	EBR	NBL	NBT	SBT	SBR
Lane Configurations						
Traffic Volume (veh/h)	2	22	18	213	210	12
Future Volume (Veh/h)	2	22	18	213	210	12
Sign Control	Stop			Free	Free	
Grade	0%			0%	0%	
Peak Hour Factor	1.00	1.00	1.00	1.00	1.00	1.00
Hourly flow rate (vph)	2	22	18	213	210	12
<b>Pedestrians</b>						
Lane Width (m)						
Walking Speed (m/s)						
Percent Blockage						
Right turn flare (veh)						
Median type				None	None	
Median storage (veh)						
Upstream signal (m)				78	181	
pX, platoon unblocked						
vC, conflicting volume	465	216	222			
vC1, stage 1 conf vol						
vC2, stage 2 conf vol						
vCu, unblocked vol	465	216	222			
tC, single (s)	6.4	6.2	4.1			
tC, 2 stage (s)						
tF (s)	3.5	3.3	2.2			
p0 queue free %	100	97	99			
cM capacity (veh/h)	552	829	1359			
<b>Direction, Lane #</b>	<b>EB 1</b>	<b>NB 1</b>	<b>SB 1</b>			
Volume Total	24	231	222			
Volume Left	2	18	0			
Volume Right	22	0	12			
cSH	796	1359	1700			
Volume to Capacity	0.03	0.01	0.13			
Queue Length 95th (m)	0.7	0.3	0.0			
Control Delay (s)	9.7	0.7	0.0			
Lane LOS	A	A				
Approach Delay (s)	9.7	0.7	0.0			
Approach LOS	A					
<b>Intersection Summary</b>						
Average Delay			0.8			
Intersection Capacity Utilization			37.5%	ICU Level of Service	A	
Analysis Period (min)			15			











HCM Unsignalized Intersection Capacity Analysis  
6: Forest St & Bond St

Future Total (2029) Mitigated  
AM Peak Hour

						
Movement	WBL	WBR	NBT	NBR	SBL	SBT
Lane Configurations						
Traffic Volume (veh/h)	11	16	27	2	16	58
Future Volume (Veh/h)	11	16	27	2	16	58
Sign Control	Stop		Free			Free
Grade	0%		0%			0%
Peak Hour Factor	1.00	1.00	1.00	1.00	1.00	1.00
Hourly flow rate (vph)	11	16	27	2	16	58
<b>Pedestrians</b>						
Lane Width (m)						
Walking Speed (m/s)						
Percent Blockage						
Right turn flare (veh)						
Median type	None			None		
Median storage (veh)						
Upstream signal (m)						
pX, platoon unblocked						
vC, conflicting volume	118	28			29	
vC1, stage 1 conf vol						
vC2, stage 2 conf vol						
vCu, unblocked vol	118	28			29	
tC, single (s)	6.4	6.2			4.1	
tC, 2 stage (s)						
tF (s)	3.5	3.3			2.2	
p0 queue free %	99	98			99	
cM capacity (veh/h)	874	1053			1597	
<b>Direction, Lane #</b>	<b>WB 1</b>	<b>NB 1</b>	<b>SB 1</b>			
Volume Total	27	29	74			
Volume Left	11	0	16			
Volume Right	16	2	0			
cSH	972	1700	1597			
Volume to Capacity	0.03	0.02	0.01			
Queue Length 95th (m)	0.7	0.0	0.2			
Control Delay (s)	8.8	0.0	1.6			
Lane LOS	A		A			
Approach Delay (s)	8.8	0.0	1.6			
Approach LOS	A					
<b>Intersection Summary</b>						
Average Delay			2.8			
Intersection Capacity Utilization			20.8%	ICU Level of Service	A	
Analysis Period (min)			15			

HCM Unsignalized Intersection Capacity Analysis  
7: Forest St & Richmond Rd

Future Total (2029) Mitigated  
AM Peak Hour

						
Movement	EBT	EBR	WBL	WBT	NBL	NBR
Lane Configurations						
Traffic Volume (veh/h)	692	14	26	476	17	40
Future Volume (Veh/h)	692	14	26	476	17	40
Sign Control	Free			Free	Stop	
Grade	0%			0%	0%	
Peak Hour Factor	1.00	1.00	1.00	1.00	1.00	1.00
Hourly flow rate (vph)	692	14	26	476	17	40
Pedestrians						
Lane Width (m)						
Walking Speed (m/s)						
Percent Blockage						
Right turn flare (veh)						
Median type	None			None		
Median storage veh						
Upstream signal (m)	279			154		
pX, platoon unblocked			0.88	0.91	0.88	
vC, conflicting volume			706	1227	699	
vC1, stage 1 conf vol						
vC2, stage 2 conf vol						
vCu, unblocked vol			593	1009	585	
tC, single (s)			4.1	6.4	6.2	
tC, 2 stage (s)						
tF (s)			2.2	3.5	3.3	
p0 queue free %			97	93	91	
cM capacity (veh/h)			869	238	450	
Direction, Lane #	EB 1	WB 1	WB 2	NB 1		
Volume Total	706	26	476	57		
Volume Left	0	26	0	17		
Volume Right	14	0	0	40		
cSH	1700	869	1700	356		
Volume to Capacity	0.42	0.03	0.28	0.16		
Queue Length 95th (m)	0.0	0.7	0.0	4.3		
Control Delay (s)	0.0	9.3	0.0	17.0		
Lane LOS	A			C		
Approach Delay (s)	0.0	0.5		17.0		
Approach LOS				C		
Intersection Summary						
Average Delay			1.0			
Intersection Capacity Utilization			49.6%	ICU Level of Service	A	
Analysis Period (min)			15			

HCM Unsignalized Intersection Capacity Analysis  
8: Bond St & 365 Forest

Future Total (2029) Mitigated  
AM Peak Hour

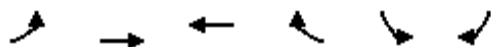

Movement	EBL	EBT	WBT	WBR	SBL	SBR
Lane Configurations		↶	↶		↶	
Traffic Volume (veh/h)	1	13	22	8	11	17
Future Volume (Veh/h)	1	13	22	8	11	17
Sign Control		Free	Free		Stop	
Grade		0%	0%		0%	
Peak Hour Factor	1.00	1.00	1.00	1.00	1.00	1.00
Hourly flow rate (vph)	1	13	22	8	11	17
Pedestrians						
Lane Width (m)						
Walking Speed (m/s)						
Percent Blockage						
Right turn flare (veh)						
Median type		None	None			
Median storage (veh)						
Upstream signal (m)						
pX, platoon unblocked						
vC, conflicting volume	30				41	26
vC1, stage 1 conf vol						
vC2, stage 2 conf vol						
vCu, unblocked vol	30				41	26
tC, single (s)	4.1				6.4	6.2
tC, 2 stage (s)						
tF (s)	2.2				3.5	3.3
p0 queue free %	100				99	98
cM capacity (veh/h)	1583				970	1050
Direction, Lane #	EB 1	WB 1	SB 1			
Volume Total	14	30	28			
Volume Left	1	0	11			
Volume Right	0	8	17			
cSH	1583	1700	1017			
Volume to Capacity	0.00	0.02	0.03			
Queue Length 95th (m)	0.0	0.0	0.6			
Control Delay (s)	0.5	0.0	8.6			
Lane LOS	A		A			
Approach Delay (s)	0.5	0.0	8.6			
Approach LOS			A			
<b>Intersection Summary</b>						
Average Delay			3.5			
Intersection Capacity Utilization			13.3%		ICU Level of Service	A
Analysis Period (min)			15			

HCM Signalized Intersection Capacity Analysis  
9: Richmond Rd & Carling Ave

Future Total (2029) Mitigated  
AM Peak Hour

Movement	EBL	EBT	EBR	WBL	WBT	WBR	NBL	NBT	NBR	SBL	SBT	SBR
Lane Configurations												
Traffic Volume (vph)	180	1712	0	5	1114	0	0	600	1369	0	346	217
Future Volume (vph)	180	1712	0	5	1114	0	0	600	1369	0	346	217
Ideal Flow (vphpl)	1800	1800	1800	1800	1800	1800	1800	1800	1800	1800	1800	1800
Total Lost time (s)	6.0	5.8		6.0	5.8			7.0	4.0		7.0	4.0
Lane Util. Factor	1.00	0.95		1.00	0.91			0.95	1.00		0.95	1.00
Frbp, ped/bikes	1.00	1.00		1.00	1.00			1.00	0.99		1.00	0.98
Flpb, ped/bikes	1.00	1.00		1.00	1.00			1.00	1.00		1.00	1.00
Frt	1.00	1.00		1.00	1.00			1.00	0.85		1.00	0.85
Flt Protected	0.95	1.00		0.95	1.00			1.00	1.00		1.00	1.00
Satd. Flow (prot)	1679	3369		864	4772			3325	1495		3325	1479
Flt Permitted	0.95	1.00		0.95	1.00			1.00	1.00		1.00	1.00
Satd. Flow (perm)	1679	3369		864	4772			3325	1495		3325	1479
Peak-hour factor, PHF	1.00	1.00	1.00	1.00	1.00	1.00	1.00	1.00	1.00	1.00	1.00	1.00
Adj. Flow (vph)	180	1712	0	5	1114	0	0	600	1369	0	346	217
RTOR Reduction (vph)	0	0	0	0	0	0	0	0	0	0	0	0
Lane Group Flow (vph)	180	1712	0	5	1114	0	0	600	1369	0	346	217
Confl. Peds. (#/hr)	8		7	7		8	6		4	4		6
Confl. Bikes (#/hr)	8		7	7		8	6		4	4		6
Heavy Vehicles (%)	3%	1%	0%	100%	3%	0%	0%	4%	2%	0%	4%	3%
Bus Blockages (#/hr)	0	8	0	0	8	0	0	0	0	0	0	0
Turn Type	Prot	NA		Prot	NA			NA	Free		NA	Free
Protected Phases	5	2		19	6			8			4	
Permitted Phases									Free			Free
Actuated Green, G (s)	18.5	63.2		3.0	53.7			39.0	130.0		39.0	130.0
Effective Green, g (s)	18.5	63.2		3.0	53.7			39.0	130.0		39.0	130.0
Actuated g/C Ratio	0.14	0.49		0.02	0.41			0.30	1.00		0.30	1.00
Clearance Time (s)	6.0	5.8			5.8			7.0			7.0	
Vehicle Extension (s)	3.0	3.0			3.0			3.0			3.0	
Lane Grp Cap (vph)	238	1637		19	1971			997	1495		997	1479
v/s Ratio Prot	0.11	c0.51		0.01	0.23			0.18			0.10	
v/s Ratio Perm									c0.92			0.15
v/c Ratio	0.76	1.05		0.26	0.57			0.60	0.92		0.35	0.15
Uniform Delay, d1	53.6	33.4		62.4	29.2			38.9	0.0		35.6	0.0
Progression Factor	1.00	1.00		0.97	0.84			1.00	1.00		0.92	1.00
Incremental Delay, d2	12.8	35.3		7.1	1.1			2.7	10.3		0.2	0.2
Delay (s)	66.4	68.7		67.8	25.8			41.6	10.3		32.8	0.2
Level of Service	E	E		E	C			D	B		C	A
Approach Delay (s)		68.5			26.0			19.8			20.2	
Approach LOS		E			C			B			C	
<b>Intersection Summary</b>												
HCM 2000 Control Delay			37.7									D
HCM 2000 Volume to Capacity ratio			1.16									
Actuated Cycle Length (s)			130.0									24.8
Intersection Capacity Utilization			106.5%									G
Analysis Period (min)			15									

c Critical Lane Group

Timing Report, Sorted By Phase  
9: Richmond Rd & Carling Ave

Future Total (2029) Mitigated  
AM Peak Hour



Phase Number	1	2	4	5	6	8	9
Movement	WBL	EBT	SBT	EBL	WBT	NBT	WBL
Lead/Lag	Lead	Lag		Lead	Lag		
Lead-Lag Optimize							
Recall Mode	None	C-Max	None	None	C-Max	Max	None
Maximum Split (s)	16	57	46	29	55	46	11
Maximum Split (%)	12.3%	43.8%	35.4%	22.3%	42.3%	35.4%	8.5%
Minimum Split (s)	16	36.8	46	16	36.8	46	11
Yellow Time (s)	3.7	3.7	3.7	3.7	3.7	3.7	3.7
All-Red Time (s)	2.3	2.1	3.3	2.3	2.1	3.3	2.3
Minimum Initial (s)	10	10	10	10	10	10	5
Vehicle Extension (s)	3	3	3	3	3	3	3
Minimum Gap (s)	3	3	3	3	3	3	3
Time Before Reduce (s)	0	0	0	0	0	0	0
Time To Reduce (s)	0	0	0	0	0	0	0
Walk Time (s)		10	10		10	10	
Flash Dont Walk (s)		21	29		21	29	
Dual Entry	No	Yes	Yes	No	Yes	Yes	No
Inhibit Max	Yes	Yes	Yes	Yes	Yes	Yes	Yes
Start Time (s)	18	34	102	18	47	102	91
End Time (s)	34	91	18	47	102	18	102
Yield/Force Off (s)	28	85.2	11	41	96.2	11	96
Yield/Force Off 170(s)	28	64.2	112	41	75.2	112	96
Local Start Time (s)	101	117	55	101	0	55	44
Local Yield (s)	111	38.2	94	124	49.2	94	49
Local Yield 170(s)	111	17.2	65	124	28.2	65	49

Intersection Summary

Cycle Length	130
Control Type	Actuated-Coordinated
Natural Cycle	150
Offset: 47 (36%), Referenced to phase 2:EBT and 6:WBT, Start of Green	

Splits and Phases: 9: Richmond Rd & Carling Ave

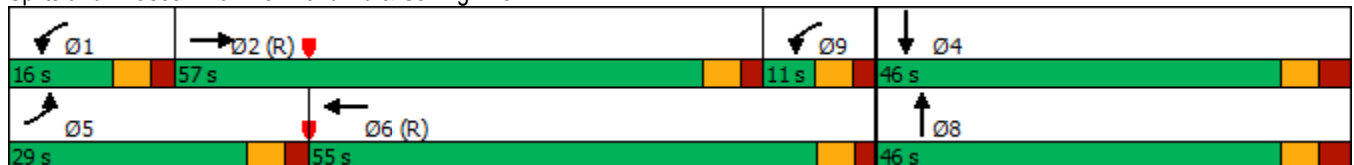



HCM Signalized Intersection Capacity Analysis  
10: Poulin St & Richmond Rd

Future Total (2029) Mitigated  
AM Peak Hour

Movement	EBL	EBT	EBR	WBL	WBT	WBR	NBL	NBT	NBR	SBL	SBT	SBR
Lane Configurations												
Traffic Volume (vph)	147	631	3	0	462	33	3	22	4	83	0	99
Future Volume (vph)	147	631	3	0	462	33	3	22	4	83	0	99
Ideal Flow (vphpl)	1800	1800	1800	1800	1800	1800	1800	1800	1800	1800	1800	1800
Total Lost time (s)	6.3	6.3			6.3			6.2			6.2	6.2
Lane Util. Factor	1.00	1.00			0.95			1.00			1.00	1.00
Frbp, ped/bikes	1.00	1.00			1.00			0.99			1.00	0.97
Flpb, ped/bikes	0.99	1.00			1.00			1.00			0.99	1.00
Frt	1.00	1.00			0.99			0.98			1.00	0.85
Flt Protected	0.95	1.00			1.00			0.99			0.95	1.00
Satd. Flow (prot)	1624	1732			3287			1686			1452	1422
Flt Permitted	0.47	1.00			1.00			0.97			0.74	1.00
Satd. Flow (perm)	805	1732			3287			1645			1128	1422
Peak-hour factor, PHF	1.00	1.00	1.00	1.00	1.00	1.00	1.00	1.00	1.00	1.00	1.00	1.00
Adj. Flow (vph)	147	631	3	0	462	33	3	22	4	83	0	99
RTOR Reduction (vph)	0	0	0	0	3	0	0	4	0	0	0	87
Lane Group Flow (vph)	147	634	0	0	492	0	0	25	0	0	83	12
Confl. Peds. (#/hr)	10		5	5		10	7		4	4		7
Confl. Bikes (#/hr)	10		5	5		10	7		4	4		7
Heavy Vehicles (%)	5%	5%	0%	0%	3%	15%	0%	0%	34%	18%	0%	5%
Turn Type	Perm	NA			NA		Perm	NA		Perm	NA	Perm
Protected Phases		2			6			8			4	
Permitted Phases	2						8		4			4
Actuated Green, G (s)	102.2	102.2			102.2			15.3			15.3	15.3
Effective Green, g (s)	102.2	102.2			102.2			15.3			15.3	15.3
Actuated g/C Ratio	0.79	0.79			0.79			0.12			0.12	0.12
Clearance Time (s)	6.3	6.3			6.3			6.2			6.2	6.2
Vehicle Extension (s)	3.0	3.0			3.0			3.0			3.0	3.0
Lane Grp Cap (vph)	632	1361			2584			193			132	167
v/s Ratio Prot		c0.37			0.15							
v/s Ratio Perm	0.18							0.02			c0.07	0.01
v/c Ratio	0.23	0.47			0.19			0.13			0.63	0.07
Uniform Delay, d1	3.6	4.7			3.5			51.4			54.6	51.0
Progression Factor	0.03	0.86			1.00			1.47			1.00	1.00
Incremental Delay, d2	0.7	0.9			0.2			0.3			9.0	0.2
Delay (s)	0.8	5.0			3.7			75.8			63.7	51.2
Level of Service	A	A			A			E			E	D
Approach Delay (s)		4.2			3.7			75.8			56.9	
Approach LOS		A			A			E			E	
<b>Intersection Summary</b>												
HCM 2000 Control Delay			11.9		HCM 2000 Level of Service			B				
HCM 2000 Volume to Capacity ratio			0.49									
Actuated Cycle Length (s)			130.0		Sum of lost time (s)			12.5				
Intersection Capacity Utilization			59.5%		ICU Level of Service			B				
Analysis Period (min)			15									
c Critical Lane Group												

Timing Report, Sorted By Phase  
10: Poulin St & Richmond Rd

Future Total (2029) Mitigated  
AM Peak Hour



Phase Number	2	4	6	8
Movement	EBTL	SBTL	WBT	NBTL
Lead/Lag				
Lead-Lag Optimize				
Recall Mode	C-Max	None	C-Max	None
Maximum Split (s)	96	34	96	34
Maximum Split (%)	73.8%	26.2%	73.8%	26.2%
Minimum Split (s)	30.3	33.2	30.3	33.2
Yellow Time (s)	3.3	3.3	3.3	3.3
All-Red Time (s)	3	2.9	3	2.9
Minimum Initial (s)	10	10	10	10
Vehicle Extension (s)	3	3	3	3
Minimum Gap (s)	3	3	3	3
Time Before Reduce (s)	0	0	0	0
Time To Reduce (s)	0	0	0	0
Walk Time (s)	7	7	7	7
Flash Dont Walk (s)	17	20	17	20
Dual Entry	Yes	Yes	Yes	Yes
Inhibit Max	Yes	Yes	Yes	Yes
Start Time (s)	90	56	90	56
End Time (s)	56	90	56	90
Yield/Force Off (s)	49.7	83.8	49.7	83.8
Yield/Force Off 170(s)	32.7	63.8	32.7	63.8
Local Start Time (s)	0	96	0	96
Local Yield (s)	89.7	123.8	89.7	123.8
Local Yield 170(s)	72.7	103.8	72.7	103.8

Intersection Summary





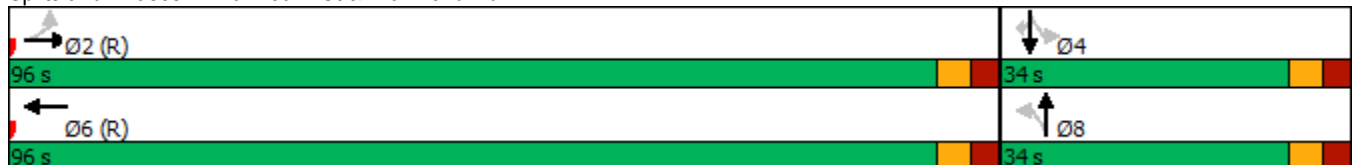













Cycle Length	130
Control Type	Actuated-Coordinated
Natural Cycle	70
Offset: 90 (69%), Referenced to phase 2:EBTL and 6:WBT, Start of Green	

Splits and Phases: 10: Poulin St & Richmond Rd



HCM Signalized Intersection Capacity Analysis  
1: Croydon Ave & Richmond Rd

Future Total (2029) Mitigated  
PM Peak Hour

												
Movement	EBL	EBT	EBR	WBL	WBT	WBR	NBL	NBT	NBR	SBL	SBT	SBR
Lane Configurations												
Traffic Volume (vph)	29	528	133	68	907	20	160	109	41	16	69	22
Future Volume (vph)	29	528	133	68	907	20	160	109	41	16	69	22
Ideal Flow (vphpl)	1800	1800	1800	1800	1800	1800	1800	1800	1800	1800	1800	1800
Lane Width	3.4	3.4	3.7	3.0	3.4	3.7	3.5	3.5	3.7	3.7	4.8	3.7
Total Lost time (s)	6.4	6.4		6.4	6.4		6.1	6.1			6.1	
Lane Util. Factor	1.00	1.00		1.00	1.00		1.00	1.00			1.00	
Frbp, ped/bikes	1.00	0.99		1.00	1.00		1.00	0.97			0.99	
Flpb, ped/bikes	1.00	1.00		0.99	1.00		0.96	1.00			0.99	
Frtp	1.00	0.97		1.00	1.00		1.00	0.96			0.97	
Fltp Protected	0.95	1.00		0.95	1.00		0.95	1.00			0.99	
Satd. Flow (prot)	1672	1565		1541	1649		1559	1634			1917	
Fltp Permitted	0.18	1.00		0.34	1.00		0.73	1.00			0.94	
Satd. Flow (perm)	317	1565		544	1649		1200	1634			1812	
Peak-hour factor, PHF	1.00	1.00	1.00	1.00	1.00	1.00	1.00	1.00	1.00	1.00	1.00	1.00
Adj. Flow (vph)	29	528	133	68	907	20	160	109	41	16	69	22
RTOR Reduction (vph)	0	8	0	0	1	0	0	18	0	0	13	0
Lane Group Flow (vph)	29	653	0	68	926	0	160	132	0	0	94	0
Confl. Peds. (#/hr)	30		24	24		30	29		59	59		29
Heavy Vehicles (%)	0%	2%	8%	2%	2%	0%	4%	0%	4%	0%	0%	0%
Bus Blockages (#/hr)	0	10	0	0	10	0	0	0	0	0	0	0
Turn Type	Perm	NA		Perm	NA		Perm	NA		Perm	NA	
Protected Phases		2			6			8			4	
Permitted Phases	2			6			8			4		
Actuated Green, G (s)	55.8	55.8		55.8	55.8		16.7	16.7			16.7	
Effective Green, g (s)	55.8	55.8		55.8	55.8		16.7	16.7			16.7	
Actuated g/C Ratio	0.66	0.66		0.66	0.66		0.20	0.20			0.20	
Clearance Time (s)	6.4	6.4		6.4	6.4		6.1	6.1			6.1	
Vehicle Extension (s)	3.0	3.0		3.0	3.0		3.0	3.0			3.0	
Lane Grp Cap (vph)	208	1027		357	1082		235	321			356	
v/s Ratio Prot		0.42			c0.56			0.08				
v/s Ratio Perm	0.09			0.12			c0.13				0.05	
v/c Ratio	0.14	0.64		0.19	0.86		0.68	0.41			0.26	
Uniform Delay, d1	5.5	8.6		5.7	11.5		31.7	29.8			28.9	
Progression Factor	1.00	1.00		1.00	1.00		1.00	1.00			1.00	
Incremental Delay, d2	1.4	3.0		1.2	8.7		7.9	0.9			0.4	
Delay (s)	6.9	11.6		6.9	20.2		39.5	30.7			29.3	
Level of Service	A	B		A	C		D	C			C	
Approach Delay (s)		11.4			19.3			35.3			29.3	
Approach LOS		B			B			D			C	
<b>Intersection Summary</b>												
HCM 2000 Control Delay			19.6				HCM 2000 Level of Service				B	
HCM 2000 Volume to Capacity ratio			0.81									
Actuated Cycle Length (s)			85.0				Sum of lost time (s)			12.5		
Intersection Capacity Utilization			90.8%				ICU Level of Service			E		
Analysis Period (min)			15									

c Critical Lane Group

Timing Report, Sorted By Phase  
1: Croydon Ave & Richmond Rd

Future Total (2029) Mitigated  
PM Peak Hour



Phase Number	2	4	6	8
Movement	EBTL	SBTL	WBTL	NBTL
Lead/Lag				
Lead-Lag Optimize				
Recall Mode	C-Max	None	C-Max	None
Maximum Split (s)	53.9	31.1	53.9	31.1
Maximum Split (%)	63.4%	36.6%	63.4%	36.6%
Minimum Split (s)	26.4	31.1	26.4	31.1
Yellow Time (s)	3.3	3.3	3.3	3.3
All-Red Time (s)	3.1	2.8	3.1	2.8
Minimum Initial (s)	10	10	10	10
Vehicle Extension (s)	3	3	3	3
Minimum Gap (s)	3	3	3	3
Time Before Reduce (s)	0	0	0	0
Time To Reduce (s)	0	0	0	0
Walk Time (s)	7	7	7	7
Flash Dont Walk (s)	13	18	13	18
Dual Entry	Yes	Yes	Yes	Yes
Inhibit Max	Yes	Yes	Yes	Yes
Start Time (s)	75	43.9	75	43.9
End Time (s)	43.9	75	43.9	75
Yield/Force Off (s)	37.5	68.9	37.5	68.9
Yield/Force Off 170(s)	24.5	50.9	24.5	50.9
Local Start Time (s)	0	53.9	0	53.9
Local Yield (s)	47.5	78.9	47.5	78.9
Local Yield 170(s)	34.5	60.9	34.5	60.9

Intersection Summary

Cycle Length	85
Control Type	Actuated-Coordinated
Natural Cycle	90
Offset: 75 (88%), Referenced to phase 2:EBTL and 6:WBTL, Start of Green	

Splits and Phases: 1: Croydon Ave & Richmond Rd

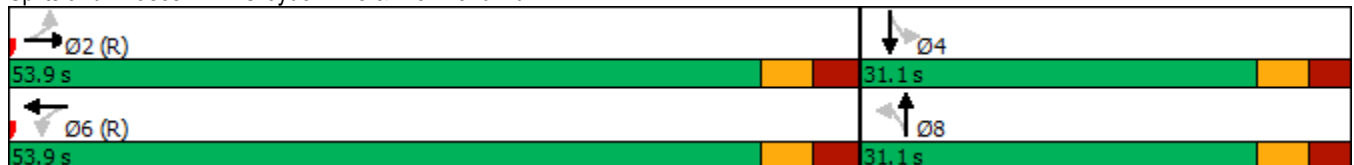

HCM Signalized Intersection Capacity Analysis  
 2: Alpine Ave/1460 Richmond & Carling Ave

Future Total (2029) Mitigated  
 PM Peak Hour



Movement	EBL	EBT	EBR	WBL	WBT	WBR	NBL	NBT	NBR	SBL	SBT	SBR
Lane Configurations	↙	↑↑↑		↙	↑↑↑			↕			↕	
Traffic Volume (vph)	29	1352	10	57	2178	85	21	16	33	53	19	40
Future Volume (vph)	29	1352	10	57	2178	85	21	16	33	53	19	40
Ideal Flow (vphpl)	1800	1800	1800	1800	1800	1800	1800	1800	1800	1800	1800	1800
Lane Width	3.0	3.6	3.7	3.0	3.7	3.7	3.7	4.8	3.7	3.7	3.6	3.7
Total Lost time (s)	5.9	5.9		5.9	5.9			6.7			6.7	
Lane Util. Factor	1.00	0.91		1.00	0.91			1.00			1.00	
Frbp, ped/bikes	1.00	1.00		1.00	1.00			0.98			0.98	
Flpb, ped/bikes	1.00	1.00		1.00	1.00			0.99			0.99	
Frtr	1.00	1.00		1.00	0.99			0.94			0.95	
Fltr Protected	0.95	1.00		0.95	1.00			0.99			0.98	
Satd. Flow (prot)	1596	4760		1549	4821			1742			1609	
Fltr Permitted	0.05	1.00		0.17	1.00			0.85			0.84	
Satd. Flow (perm)	88	4760		271	4821			1498			1380	
Peak-hour factor, PHF	1.00	1.00	1.00	1.00	1.00	1.00	1.00	1.00	1.00	1.00	1.00	1.00
Adj. Flow (vph)	29	1352	10	57	2178	85	21	16	33	53	19	40
RTOR Reduction (vph)	0	0	0	0	2	0	0	29	0	0	19	0
Lane Group Flow (vph)	29	1362	0	57	2261	0	0	41	0	0	93	0
Confl. Peds. (#/hr)	40		13	13		40	32		14	14		32
Heavy Vehicles (%)	0%	2%	0%	3%	1%	0%	12%	0%	4%	3%	0%	0%
Bus Blockages (#/hr)	0	8	0	0	8	0	0	0	0	0	0	0
Turn Type	pm+pt	NA		pm+pt	NA		Perm	NA		Perm	NA	
Protected Phases	5	2		1	6			8			4	
Permitted Phases	2			6			8			4		
Actuated Green, G (s)	95.1	91.3		98.5	93.0			14.7			14.7	
Effective Green, g (s)	95.1	91.3		98.5	93.0			14.7			14.7	
Actuated g/C Ratio	0.73	0.70		0.76	0.72			0.11			0.11	
Clearance Time (s)	5.9	5.9		5.9	5.9			6.7			6.7	
Vehicle Extension (s)	3.0	3.0		3.0	3.0			3.0			3.0	
Lane Grp Cap (vph)	108	3342		259	3448			169			156	
v/s Ratio Prot	0.01	0.29		c0.01	c0.47							
v/s Ratio Perm	0.19			0.16				0.03			c0.07	
v/c Ratio	0.27	0.41		0.22	0.66			0.24			0.60	
Uniform Delay, d1	7.7	8.1		4.5	9.9			52.6			54.8	
Progression Factor	2.39	1.28		1.40	0.86			1.00			1.00	
Incremental Delay, d2	1.3	0.3		0.2	0.6			0.7			6.1	
Delay (s)	19.6	10.7		6.5	9.1			53.3			60.9	
Level of Service	B	B		A	A			D			E	
Approach Delay (s)		10.9			9.0			53.3			60.9	
Approach LOS		B			A			D			E	

Intersection Summary		
HCM 2000 Control Delay	12.0	HCM 2000 Level of Service
HCM 2000 Volume to Capacity ratio	0.64	B
Actuated Cycle Length (s)	130.0	Sum of lost time (s)
Intersection Capacity Utilization	84.3%	18.5
Analysis Period (min)	15	ICU Level of Service
		E

c Critical Lane Group

Timing Report, Sorted By Phase  
 2: Alpine Ave/1460 Richmond & Carling Ave

Future Total (2029) Mitigated  
 PM Peak Hour



Phase Number	1	2	4	5	6	8
Movement	WBL	EBTL	SBTL	EBL	WBTL	NBTL
Lead/Lag	Lead	Lag		Lead	Lag	
Lead-Lag Optimize						
Recall Mode	None	C-Max	None	None	C-Max	None
Maximum Split (s)	12	75	43	12	75	43
Maximum Split (%)	9.2%	57.7%	33.1%	9.2%	57.7%	33.1%
Minimum Split (s)	10.9	33.9	42.7	10.9	33.9	32.7
Yellow Time (s)	3.7	3.7	3.3	3.7	3.7	3.3
All-Red Time (s)	2.2	2.2	3.4	2.2	2.2	3.4
Minimum Initial (s)	5	10	10	5	10	10
Vehicle Extension (s)	3	3	3	3	3	3
Minimum Gap (s)	3	3	3	3	3	3
Time Before Reduce (s)	0	0	0	0	0	0
Time To Reduce (s)	0	0	0	0	0	0
Walk Time (s)		16	7		16	7
Flash Dont Walk (s)		12	29		12	19
Dual Entry	No	Yes	Yes	No	Yes	Yes
Inhibit Max	Yes	Yes	Yes	Yes	Yes	Yes
Start Time (s)	127	9	84	127	9	84
End Time (s)	9	84	127	9	84	127
Yield/Force Off (s)	3.1	78.1	120.3	3.1	78.1	120.3
Yield/Force Off 170(s)	3.1	66.1	91.3	3.1	66.1	101.3
Local Start Time (s)	118	0	75	118	0	75
Local Yield (s)	124.1	69.1	111.3	124.1	69.1	111.3
Local Yield 170(s)	124.1	57.1	82.3	124.1	57.1	92.3

Intersection Summary

Cycle Length	130
Control Type	Actuated-Coordinated
Natural Cycle	110
Offset: 9 (7%), Referenced to phase 2:EBTL and 6:WBTL, Start of Green	

Splits and Phases: 2: Alpine Ave/1460 Richmond & Carling Ave

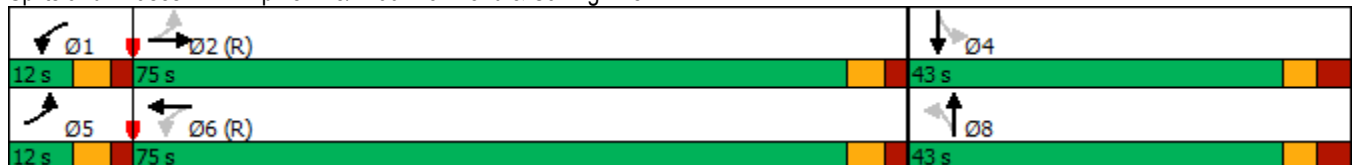

HCM Signalized Intersection Capacity Analysis  
3: Carling Ave & Croydon Ave

Future Total (2029) Mitigated  
PM Peak Hour

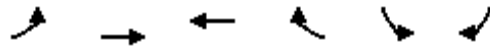

Movement	EBL	EBT	WBT	WBR	SBL	SBR
Lane Configurations	↘	↑↑↑	↑↑↑		↘↘	
Traffic Volume (vph)	103	1374	2360	165	185	115
Future Volume (vph)	103	1374	2360	165	185	115
Ideal Flow (vphpl)	1800	1800	1800	1800	1800	1800
Lane Width	2.8	3.6	3.7	3.7	3.7	3.3
Total Lost time (s)	5.9	5.9	5.9		6.3	
Lane Util. Factor	1.00	0.91	0.91		0.97	
Frpb, ped/bikes	1.00	1.00	0.99		0.99	
Flpb, ped/bikes	1.00	1.00	1.00		1.00	
Frt	1.00	1.00	0.99		0.94	
Flt Protected	0.95	1.00	1.00		0.97	
Satd. Flow (prot)	1527	4696	4696		3103	
Flt Permitted	0.95	1.00	1.00		0.97	
Satd. Flow (perm)	1527	4696	4696		3103	
Peak-hour factor, PHF	1.00	1.00	1.00	1.00	1.00	1.00
Adj. Flow (vph)	103	1374	2360	165	185	115
RTOR Reduction (vph)	0	0	5	0	94	0
Lane Group Flow (vph)	103	1374	2520	0	206	0
Confl. Peds. (#/hr)	39			39	3	22
Heavy Vehicles (%)	2%	2%	1%	5%	4%	0%
Bus Blockages (#/hr)	0	19	19	0	0	0
Turn Type	Prot	NA	NA		Prot	
Protected Phases	5	2	6		7	
Permitted Phases						
Actuated Green, G (s)	17.6	103.7	80.2		14.1	
Effective Green, g (s)	17.6	103.7	80.2		14.1	
Actuated g/C Ratio	0.14	0.80	0.62		0.11	
Clearance Time (s)	5.9	5.9	5.9		6.3	
Vehicle Extension (s)	3.0	3.0	3.0		3.0	
Lane Grp Cap (vph)	206	3745	2897		336	
v/s Ratio Prot	c0.07	0.29	c0.54		c0.07	
v/s Ratio Perm						
v/c Ratio	0.50	0.37	0.87		0.61	
Uniform Delay, d1	52.1	3.8	20.6		55.4	
Progression Factor	1.33	0.35	1.00		1.00	
Incremental Delay, d2	1.8	0.3	3.9		3.3	
Delay (s)	70.9	1.6	24.5		58.7	
Level of Service	E	A	C		E	
Approach Delay (s)		6.4	24.5		58.7	
Approach LOS		A	C		E	

Intersection Summary

HCM 2000 Control Delay	20.7	HCM 2000 Level of Service	C
HCM 2000 Volume to Capacity ratio	0.78		
Actuated Cycle Length (s)	130.0	Sum of lost time (s)	18.1
Intersection Capacity Utilization	91.7%	ICU Level of Service	F
Analysis Period (min)	15		

c Critical Lane Group

Timing Report, Sorted By Phase  
3: Carling Ave & Croydon Ave

Future Total (2029) Mitigated  
PM Peak Hour



Phase Number	2	5	6	7
Movement	EBT	EBL	WBT	SBL
Lead/Lag		Lead	Lag	
Lead-Lag Optimize				
Recall Mode	C-Max	None	C-Max	None
Maximum Split (s)	92	14	78	38
Maximum Split (%)	70.8%	10.8%	60.0%	29.2%
Minimum Split (s)	23.9	10.9	28.9	37.3
Yellow Time (s)	3.7	3.7	3.7	3.3
All-Red Time (s)	2.2	2.2	2.2	3
Minimum Initial (s)	10	5	10	10
Vehicle Extension (s)	3	3	3	3
Minimum Gap (s)	3	3	3	3
Time Before Reduce (s)	0	0	0	0
Time To Reduce (s)	0	0	0	0
Walk Time (s)			7	21
Flash Dont Walk (s)			16	10
Dual Entry	Yes	No	Yes	No
Inhibit Max	Yes	Yes	Yes	Yes
Start Time (s)	4	4	18	96
End Time (s)	96	18	96	4
Yield/Force Off (s)	90.1	12.1	90.1	127.7
Yield/Force Off 170(s)	90.1	12.1	74.1	117.7
Local Start Time (s)	116	116	0	78
Local Yield (s)	72.1	124.1	72.1	109.7
Local Yield 170(s)	72.1	124.1	56.1	99.7

Intersection Summary

Cycle Length	130
Control Type	Actuated-Coordinated
Natural Cycle	120
Offset: 18 (14%), Referenced to phase 2:EBT and 6:WBT, Start of Green	

Splits and Phases: 3: Carling Ave & Croydon Ave

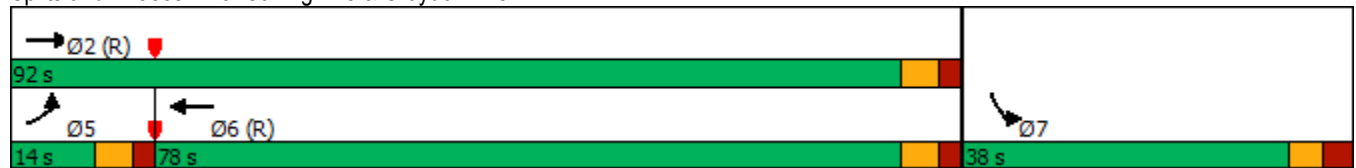



HCM Unsignalized Intersection Capacity Analysis  
4: Carling Ave & Forest St

Future Total (2029) Mitigated  
PM Peak Hour

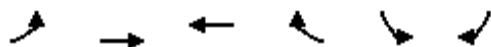

Movement	EBL	EBT	WBT	WBR	SBL	SBR	
Lane Configurations		↑↑↑	↑↑↑			↑	
Traffic Volume (veh/h)	0	1437	2200	40	0	119	
Future Volume (Veh/h)	0	1437	2200	40	0	119	
Sign Control		Free	Free		Stop		
Grade		0%	0%		0%		
Peak Hour Factor	1.00	1.00	1.00	1.00	1.00	1.00	
Hourly flow rate (vph)	0	1437	2200	40	0	119	
<b>Pedestrians</b>							
Lane Width (m)							
Walking Speed (m/s)							
Percent Blockage							
Right turn flare (veh)							
Median type		None	None				
Median storage (veh)							
Upstream signal (m)		55	141				
pX, platoon unblocked	0.57				0.63	0.57	
vC, conflicting volume	2240				2699	753	
vC1, stage 1 conf vol							
vC2, stage 2 conf vol							
vCu, unblocked vol	534				384	0	
tC, single (s)	4.1				6.8	6.9	
tC, 2 stage (s)							
tF (s)	2.2				3.5	3.3	
p0 queue free %	100				100	81	
cM capacity (veh/h)	595				375	622	
Direction, Lane #	EB 1	EB 2	EB 3	WB 1	WB 2	WB 3	SB 1
Volume Total	479	479	479	880	880	480	119
Volume Left	0	0	0	0	0	0	0
Volume Right	0	0	0	0	0	40	119
cSH	1700	1700	1700	1700	1700	1700	622
Volume to Capacity	0.28	0.28	0.28	0.52	0.52	0.28	0.19
Queue Length 95th (m)	0.0	0.0	0.0	0.0	0.0	0.0	5.3
Control Delay (s)	0.0	0.0	0.0	0.0	0.0	0.0	12.2
Lane LOS							B
Approach Delay (s)	0.0			0.0			12.2
Approach LOS							B
<b>Intersection Summary</b>							
Average Delay			0.4				
Intersection Capacity Utilization			60.3%		ICU Level of Service		B
Analysis Period (min)			15				

HCM Unsignalized Intersection Capacity Analysis  
5: Croydon Ave & Bond St









Future Total (2029) Mitigated  
PM Peak Hour



Movement	EBL	EBR	NBL	NBT	SBT	SBR
Lane Configurations						
Traffic Volume (veh/h)	2	19	28	239	281	16
Future Volume (Veh/h)	2	19	28	239	281	16
Sign Control	Stop			Free	Free	
Grade	0%			0%	0%	
Peak Hour Factor	1.00	1.00	1.00	1.00	1.00	1.00
Hourly flow rate (vph)	2	19	28	239	281	16
Pedestrians						
Lane Width (m)						
Walking Speed (m/s)						
Percent Blockage						
Right turn flare (veh)						
Median type				None	None	
Median storage veh						
Upstream signal (m)				78	181	
pX, platoon unblocked						
vC, conflicting volume	584	289	297			
vC1, stage 1 conf vol						
vC2, stage 2 conf vol						
vCu, unblocked vol	584	289	297			
tC, single (s)	6.4	6.2	4.1			
tC, 2 stage (s)						
tF (s)	3.5	3.3	2.2			
p0 queue free %	100	97	98			
cM capacity (veh/h)	467	755	1276			
Direction, Lane #	EB 1	NB 1	SB 1			
Volume Total	21	267	297			
Volume Left	2	28	0			
Volume Right	19	0	16			
cSH	713	1276	1700			
Volume to Capacity	0.03	0.02	0.17			
Queue Length 95th (m)	0.7	0.5	0.0			
Control Delay (s)	10.2	1.0	0.0			
Lane LOS	B	A				
Approach Delay (s)	10.2	1.0	0.0			
Approach LOS	B					
Intersection Summary						
Average Delay			0.8			
Intersection Capacity Utilization			44.9%	ICU Level of Service	A	
Analysis Period (min)			15			

HCM Unsignalized Intersection Capacity Analysis  
6: Forest St & Bond St

Future Total (2029) Mitigated  
PM Peak Hour

						
Movement	WBL	WBR	NBT	NBR	SBL	SBT
Lane Configurations						
Traffic Volume (veh/h)	6	13	40	2	33	114
Future Volume (Veh/h)	6	13	40	2	33	114
Sign Control	Stop		Free		Free	
Grade	0%		0%		0%	
Peak Hour Factor	1.00	1.00	1.00	1.00	1.00	1.00
Hourly flow rate (vph)	6	13	40	2	33	114
Pedestrians						
Lane Width (m)						
Walking Speed (m/s)						
Percent Blockage						
Right turn flare (veh)						
Median type	None			None		
Median storage veh						
Upstream signal (m)						
pX, platoon unblocked						
vC, conflicting volume	221	41			42	
vC1, stage 1 conf vol						
vC2, stage 2 conf vol						
vCu, unblocked vol	221	41			42	
tC, single (s)	6.4	6.2			4.1	
tC, 2 stage (s)						
tF (s)	3.5	3.3			2.2	
p0 queue free %	99	99			98	
cM capacity (veh/h)	756	1036			1580	
Direction, Lane #	WB 1	NB 1	SB 1			
Volume Total	19	42	147			
Volume Left	6	0	33			
Volume Right	13	2	0			
cSH	927	1700	1580			
Volume to Capacity	0.02	0.02	0.02			
Queue Length 95th (m)	0.5	0.0	0.5			
Control Delay (s)	9.0	0.0	1.8			
Lane LOS	A		A			
Approach Delay (s)	9.0	0.0	1.8			
Approach LOS	A					
Intersection Summary						
Average Delay			2.1			
Intersection Capacity Utilization			24.9%	ICU Level of Service	A	
Analysis Period (min)			15			

HCM Unsignalized Intersection Capacity Analysis  
7: Forest St & Richmond Rd

Future Total (2029) Mitigated  
PM Peak Hour

	→	↘	↙	←	↖	↗
Movement	EBT	EBR	WBL	WBT	NBL	NBR
Lane Configurations	↗		↖	↗	↘	
Traffic Volume (veh/h)	657	16	54	1036	15	33
Future Volume (Veh/h)	657	16	54	1036	15	33
Sign Control	Free			Free	Stop	
Grade	0%			0%	0%	
Peak Hour Factor	1.00	1.00	1.00	1.00	1.00	1.00
Hourly flow rate (vph)	657	16	54	1036	15	33
<b>Pedestrians</b>						
Lane Width (m)						
Walking Speed (m/s)						
Percent Blockage						
Right turn flare (veh)						
Median type	None			None		
Median storage (veh)						
Upstream signal (m)	279			154		
pX, platoon unblocked				0.89	0.53	0.89
vC, conflicting volume				673	1809	665
vC1, stage 1 conf vol						
vC2, stage 2 conf vol						
vCu, unblocked vol				572	1619	563
tC, single (s)				4.1	6.4	6.2
tC, 2 stage (s)						
tF (s)				2.2	3.5	3.3
p0 queue free %				94	74	93
cM capacity (veh/h)				901	58	472
<b>Direction, Lane #</b>	<b>EB 1</b>	<b>WB 1</b>	<b>WB 2</b>	<b>NB 1</b>		
Volume Total	673	54	1036	48		
Volume Left	0	54	0	15		
Volume Right	16	0	0	33		
cSH	1700	901	1700	145		
Volume to Capacity	0.40	0.06	0.61	0.33		
Queue Length 95th (m)	0.0	1.5	0.0	10.1		
Control Delay (s)	0.0	9.3	0.0	41.6		
Lane LOS	A			E		
Approach Delay (s)	0.0	0.5		41.6		
Approach LOS				E		
<b>Intersection Summary</b>						
Average Delay				1.4		
Intersection Capacity Utilization				67.6%	ICU Level of Service	C
Analysis Period (min)				15		

HCM Unsignalized Intersection Capacity Analysis  
8: Bond St & 365 Forest

























Future Total (2029) Mitigated  
PM Peak Hour



Movement	EBL	EBT	WBT	WBR	SBL	SBR
Lane Configurations		↖	↗		↘	
Traffic Volume (veh/h)	3	15	26	17	5	7
Future Volume (Veh/h)	3	15	26	17	5	7
Sign Control		Free	Free		Stop	
Grade		0%	0%		0%	
Peak Hour Factor	1.00	1.00	1.00	1.00	1.00	1.00
Hourly flow rate (vph)	3	15	26	17	5	7
Pedestrians						
Lane Width (m)						
Walking Speed (m/s)						
Percent Blockage						
Right turn flare (veh)						
Median type		None	None			
Median storage (veh)						
Upstream signal (m)						
pX, platoon unblocked						
vC, conflicting volume	43				56	34
vC1, stage 1 conf vol						
vC2, stage 2 conf vol						
vCu, unblocked vol	43				56	34
tC, single (s)	4.1				6.4	6.2
tC, 2 stage (s)						
tF (s)	2.2				3.5	3.3
p0 queue free %	100				99	99
cM capacity (veh/h)	1566				950	1039
Direction, Lane #	EB 1	WB 1	SB 1			
Volume Total	18	43	12			
Volume Left	3	0	5			
Volume Right	0	17	7			
cSH	1566	1700	1000			
Volume to Capacity	0.00	0.03	0.01			
Queue Length 95th (m)	0.0	0.0	0.3			
Control Delay (s)	1.2	0.0	8.6			
Lane LOS	A		A			
Approach Delay (s)	1.2	0.0	8.6			
Approach LOS			A			
Intersection Summary						
Average Delay			1.7			
Intersection Capacity Utilization			13.5%		ICU Level of Service	A
Analysis Period (min)			15			

HCM Signalized Intersection Capacity Analysis  
 9: Richmond Rd & Carling Ave

Future Total (2029) Mitigated  
 PM Peak Hour

													
Movement	EBL	EBT	EBR	WBL	WBT	WBR	NBL	NBT	NBR	SBL	SBT	SBR	
Lane Configurations		 			  			 			 		
Traffic Volume (vph)	278	828	3	15	2099	2	0	549	562	0	861	391	
Future Volume (vph)	278	828	3	15	2099	2	0	549	562	0	861	391	
Ideal Flow (vphpl)	1800	1800	1800	1800	1800	1800	1800	1800	1800	1800	1800	1800	
Total Lost time (s)	6.0	5.8		6.0	5.8			7.0	4.0		7.0	4.0	
Lane Util. Factor	1.00	0.95		1.00	0.91			0.95	1.00		0.95	1.00	
Frpb, ped/bikes	1.00	1.00		1.00	1.00			1.00	0.99		1.00	0.99	
Flpb, ped/bikes	1.00	1.00		1.00	1.00			1.00	1.00		1.00	1.00	
Frt	1.00	1.00		1.00	1.00			1.00	0.85		1.00	0.85	
Flt Protected	0.95	1.00		0.95	1.00			1.00	1.00		1.00	1.00	
Satd. Flow (prot)	1695	3388		988	4919			3390	1496		3357	1497	
Flt Permitted	0.95	1.00		0.95	1.00			1.00	1.00		1.00	1.00	
Satd. Flow (perm)	1695	3388		988	4919			3390	1496		3357	1497	
Peak-hour factor, PHF	1.00	1.00	1.00	1.00	1.00	1.00	1.00	1.00	1.00	1.00	1.00	1.00	
Adj. Flow (vph)	278	828	3	15	2099	2	0	549	562	0	861	391	
RTOR Reduction (vph)	0	0	0	0	0	0	0	0	0	0	0	0	
Lane Group Flow (vph)	278	831	0	15	2101	0	0	549	562	0	861	391	
Confl. Peds. (#/hr)	7		2	2		7	2		3	3		2	
Confl. Bikes (#/hr)	7		2	2		7	2		3	3		2	
Heavy Vehicles (%)	2%	2%	0%	75%	1%	0%	2%	2%	2%	2%	3%	2%	
Turn Type	Prot	NA		Prot	NA			NA	Free		NA	Free	
Protected Phases	5	2		19	6			8			4		
Permitted Phases									Free			Free	
Actuated Green, G (s)	21.6	61.8		6.0	52.2			37.4	130.0		37.4	130.0	
Effective Green, g (s)	21.6	61.8		6.0	52.2			37.4	130.0		37.4	130.0	
Actuated g/C Ratio	0.17	0.48		0.05	0.40			0.29	1.00		0.29	1.00	
Clearance Time (s)	6.0	5.8			5.8			7.0			7.0		
Vehicle Extension (s)	3.0	3.0			3.0			3.0			3.0		
Lane Grp Cap (vph)	281	1610		45	1975			975	1496		965	1497	
v/s Ratio Prot	c0.16	0.25		0.02	c0.43			0.16			c0.26		
v/s Ratio Perm									0.38			0.26	
v/c Ratio	0.99	0.52		0.33	1.06			0.56	0.38		0.89	0.26	
Uniform Delay, d1	54.1	23.7		60.1	38.9			39.4	0.0		44.4	0.0	
Progression Factor	1.00	1.00		0.85	0.57			1.00	1.00		1.00	1.00	
Incremental Delay, d2	50.2	1.2		3.6	38.2			0.7	0.7		10.5	0.4	
Delay (s)	104.3	24.9		54.4	60.3			40.1	0.7		54.8	0.4	
Level of Service	F	C		D	E			D	A		D	A	
Approach Delay (s)		44.8			60.3			20.2			37.8		
Approach LOS		D			E			C			D		
<b>Intersection Summary</b>													
HCM 2000 Control Delay			44.2									HCM 2000 Level of Service	D
HCM 2000 Volume to Capacity ratio			1.05										
Actuated Cycle Length (s)			130.0									Sum of lost time (s)	24.8
Intersection Capacity Utilization			100.4%									ICU Level of Service	G
Analysis Period (min)			15										
c Critical Lane Group													

Timing Report, Sorted By Phase  
9: Richmond Rd & Carling Ave

Future Total (2029) Mitigated  
PM Peak Hour



Phase Number	1	2	4	5	6	8	9
Movement	WBL	EBT	SBT	EBL	WBT	NBT	WBL
Lead/Lag	Lead	Lag		Lead	Lag		
Lead-Lag Optimize							
Recall Mode	None	C-Max	None	None	C-Max	None	None
Maximum Split (s)	16	57	46	26	58	46	11
Maximum Split (%)	12.3%	43.8%	35.4%	20.0%	44.6%	35.4%	8.5%
Minimum Split (s)	16	36.8	46	16	36.8	46	11
Yellow Time (s)	3.7	3.7	3.7	3.7	3.7	3.7	3.7
All-Red Time (s)	2.3	2.1	3.3	2.3	2.1	3.3	2.3
Minimum Initial (s)	10	10	10	10	10	10	5
Vehicle Extension (s)	3	3	3	3	3	3	3
Minimum Gap (s)	3	3	3	3	3	3	3
Time Before Reduce (s)	0	0	0	0	0	0	0
Time To Reduce (s)	0	0	0	0	0	0	0
Walk Time (s)		10	10		10	10	
Flash Dont Walk (s)		21	29		21	29	
Dual Entry	No	Yes	Yes	No	Yes	Yes	No
Inhibit Max	Yes	Yes	Yes	Yes	Yes	Yes	Yes
Start Time (s)	21	37	105	21	47	105	94
End Time (s)	37	94	21	47	105	21	105
Yield/Force Off (s)	31	88.2	14	41	99.2	14	99
Yield/Force Off 170(s)	31	67.2	115	41	78.2	115	99
Local Start Time (s)	104	120	58	104	0	58	47
Local Yield (s)	114	41.2	97	124	52.2	97	52
Local Yield 170(s)	114	20.2	68	124	31.2	68	52

Intersection Summary





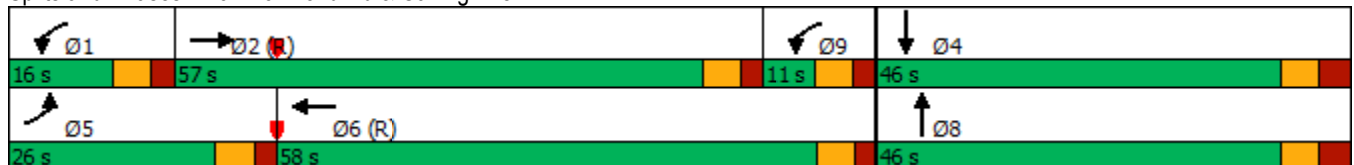















Cycle Length	130
Control Type	Actuated-Coordinated
Natural Cycle	140
Offset: 47 (36%), Referenced to phase 2:EBT and 6:WBT, Start of Green	

Splits and Phases: 9: Richmond Rd & Carling Ave



HCM Signalized Intersection Capacity Analysis  
10: Poulin St & Richmond Rd

Future Total (2029) Mitigated  
PM Peak Hour

													
Movement	EBL	EBT	EBR	WBL	WBT	WBR	NBL	NBT	NBR	SBL	SBT	SBR	
Lane Configurations													
Traffic Volume (vph)	249	529	3	0	1056	50	47	66	15	81	2	149	
Future Volume (vph)	249	529	3	0	1056	50	47	66	15	81	2	149	
Ideal Flow (vphpl)	1800	1800	1800	1800	1800	1800	1800	1800	1800	1800	1800	1800	
Total Lost time (s)	6.3	6.3			6.3			6.2			6.2	6.2	
Lane Util. Factor	1.00	1.00			0.95			1.00			1.00	1.00	
Frbp, ped/bikes	1.00	1.00			1.00			0.99			1.00	0.98	
Flpb, ped/bikes	1.00	1.00			1.00			1.00			0.99	1.00	
Frt	1.00	1.00			0.99			0.98			1.00	0.85	
Flt Protected	0.95	1.00			1.00			0.98			0.95	1.00	
Satd. Flow (prot)	1729	1818			3429			1748			1722	1521	
Flt Permitted	0.14	1.00			1.00			0.84			0.63	1.00	
Satd. Flow (perm)	248	1818			3429			1503			1145	1521	
Peak-hour factor, PHF	1.00	1.00	1.00	1.00	1.00	1.00	1.00	1.00	1.00	1.00	1.00	1.00	
Adj. Flow (vph)	249	529	3	0	1056	50	47	66	15	81	2	149	
RTOR Reduction (vph)	0	0	0	0	3	0	0	7	0	0	0	128	
Lane Group Flow (vph)	249	532	0	0	1103	0	0	121	0	0	83	21	
Confl. Peds. (#/hr)	6		16	16		6	2		6	6		2	
Confl. Bikes (#/hr)	6		16	16		6	2		6	6		2	
Heavy Vehicles (%)	0%	0%	0%	2%	0%	0%	0%	0%	0%	0%	0%	0%	
Turn Type	pm+pt	NA			NA		Perm	NA		Perm	NA	Perm	
Protected Phases	5	2			6			8			4		
Permitted Phases	2						8			4		4	
Actuated Green, G (s)	64.6	64.6			42.2			12.9			12.9	12.9	
Effective Green, g (s)	64.6	64.6			42.2			12.9			12.9	12.9	
Actuated g/C Ratio	0.72	0.72			0.47			0.14			0.14	0.14	
Clearance Time (s)	6.3	6.3			6.3			6.2			6.2	6.2	
Vehicle Extension (s)	3.0	3.0			3.0			3.0			3.0	3.0	
Lane Grp Cap (vph)	442	1304			1607			215			164	218	
v/s Ratio Prot	c0.10	0.29			c0.32								
v/s Ratio Perm	0.30							c0.08			0.07	0.01	
v/c Ratio	0.56	0.41			0.69			0.56			0.51	0.10	
Uniform Delay, d1	10.4	5.1			18.7			35.9			35.6	33.5	
Progression Factor	1.00	1.00			1.00			1.00			1.00	1.00	
Incremental Delay, d2	1.6	0.9			2.4			3.4			2.4	0.2	
Delay (s)	12.1	6.0			21.1			39.3			38.1	33.7	
Level of Service	B	A			C			D			D	C	
Approach Delay (s)		7.9			21.1			39.3			35.3		
Approach LOS		A			C			D			D		
<b>Intersection Summary</b>													
HCM 2000 Control Delay			19.0									HCM 2000 Level of Service	B
HCM 2000 Volume to Capacity ratio			0.64										
Actuated Cycle Length (s)			90.0									Sum of lost time (s)	18.8
Intersection Capacity Utilization			78.4%									ICU Level of Service	D
Analysis Period (min)			15										
c Critical Lane Group													



Timing Report, Sorted By Phase  
10: Poulin St & Richmond Rd

Future Total (2029) Mitigated  
PM Peak Hour



Phase Number	2	4	5	6	8
Movement	EBTL	SBTL	EBL	WBT	NBTL
Lead/Lag			Lead	Lag	
Lead-Lag Optimize					
Recall Mode	C-Max	None	None	C-Max	None
Maximum Split (s)	56	34	15	41	34
Maximum Split (%)	62.2%	37.8%	16.7%	45.6%	37.8%
Minimum Split (s)	30.3	33.2	15	30.3	33.2
Yellow Time (s)	3.3	3.3	3.3	3.3	3.3
All-Red Time (s)	3	2.9	3	3	2.9
Minimum Initial (s)	10	10	5	10	10
Vehicle Extension (s)	3	3	3	3	3
Minimum Gap (s)	3	3	3	3	3
Time Before Reduce (s)	0	0	0	0	0
Time To Reduce (s)	0	0	0	0	0
Walk Time (s)	7	7		7	7
Flash Dont Walk (s)	17	20		17	20
Dual Entry	Yes	Yes	No	Yes	Yes
Inhibit Max	Yes	Yes	Yes	Yes	Yes
Start Time (s)	88	54	88	13	54
End Time (s)	54	88	13	54	88
Yield/Force Off (s)	47.7	81.8	6.7	47.7	81.8
Yield/Force Off 170(s)	30.7	61.8	6.7	30.7	61.8
Local Start Time (s)	75	41	75	0	41
Local Yield (s)	34.7	68.8	83.7	34.7	68.8
Local Yield 170(s)	17.7	48.8	83.7	17.7	48.8

Intersection Summary

Cycle Length	90
Control Type	Actuated-Coordinated
Natural Cycle	90
Offset: 13 (14%), Referenced to phase 2:EBTL and 6:WBT, Start of Green	

Splits and Phases: 10: Poulin St & Richmond Rd

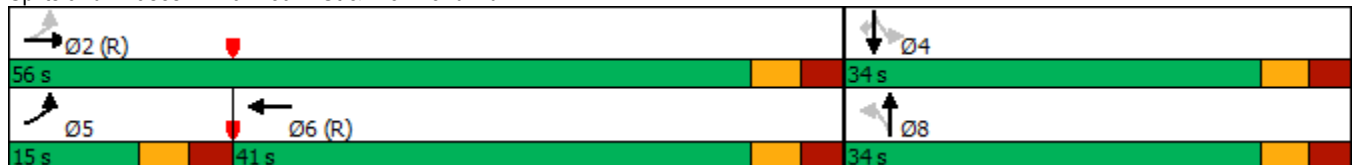

## Appendix J – City of Ottawa TIA Credential Form



## **TIA Plan Reports**

On 14 June 2017, the Council of the City of Ottawa adopted new Transportation Impact Assessment (TIA) Guidelines. In adopting the guidelines, Council established a requirement for those preparing and delivering transportation impact assessments and reports to sign a letter of certification.

Individuals submitting TIA reports will be responsible for all aspects of development-related transportation assessment and reporting, and undertaking such work, in accordance and compliance with the City of Ottawa's Official Plan, the Transportation Master Plan and the Transportation Impact Assessment (2017) Guidelines.

By submitting the attached TIA report (and any associated documents) and signing this document, the individual acknowledges that s/he meets the four criteria listed below.

### **CERTIFICATION**

1. I have reviewed and have a sound understanding of the objectives, needs and requirements of the City of Ottawa's Official Plan, Transportation Master Plan and the Transportation Impact Assessment (2017) Guidelines;
2. I have a sound knowledge of industry standard practice with respect to the preparation of transportation impact assessment reports, including multi modal level of service review;
3. I have substantial experience (more than 5 years) in undertaking and delivering transportation impact studies (analysis, reporting and geometric design) with strong background knowledge in transportation planning, engineering or traffic operations; and
4. I am either a licensed<sup>1</sup> or registered<sup>2</sup> professional in good standing, whose field of expertise [check  appropriate field(s)] is either transportation engineering  or transportation planning .

1,2 **License of registration body that oversees the profession is required to have a code of conduct and ethics guidelines that will ensure appropriate conduct and representation for transportation planning and/or transportation engineering works.**

City Of Ottawa  
Infrastructure Services and Community  
Sustainability  
Planning and Growth Management  
110 Laurier Avenue West, 4th fl.  
Ottawa, ON K1P 1J1  
Tel. : 613-580-2424  
Fax: 613-560-6006

Ville d'Ottawa  
Services d'infrastructure et Viabilité des  
collectivités  
Urbanisme et Gestion de la croissance  
110, avenue Laurier Ouest  
Ottawa (Ontario) K1P 1J1  
Tél. : 613-580-2424  
Télécopieur: 613-560-6006

Dated at Ottawa this 15<sup>th</sup> day of May, 2020.  
(City)

Name: Louis P. Desmarais, P. Eng.  
(Please Print)

Professional Title: Senior Project Manager

\_\_\_\_\_  
Signature of Individual certifier that s/he meets the above four criteria

<b>Office Contact Information (Please Print)</b>
Address: 100 - 2650 Queensview Road
City / Postal Code: Ottawa, ON K2B 8H6
Telephone / Extension: 613 688 1899 extension 3248
E-Mail Address: phil.desmarais@ottawa.ca

Stamp