



Site Servicing and Stormwater Management Design Brief

Ottawa Public Library – Library and Archives Canada Joint Facility

555 Albert Street

Ottawa, Ontario

Site Plan Application File No.: TBC

Pre-Consultation File No.: PC2020-0106

Presented to:

**Diamond Schmitt Architects and KWC Architects in
Joint Venture for the OPL-LAC Joint Facility**

Project: 190167700

June 5th, 2020

Revision No.: 0

P:\2019\190167700-OPL-LAC JOINT FACILITY\08. WORKING\REPORTS\SITE PLAN
CONTROL\REV0\DESIGN BRIEF\OPL-LAC JOINT FACILITY_CIVIL DESIGN
BRIEF_2020-06-05.DOCX

TABLE OF CONTENTS

| | Page |
|--|-------------|
| 1 INTRODUCTION | 2 |
| 1.1 Site Description and Proposed Development | 2 |
| 1.2 Background Documents | 3 |
| 1.3 Consultation and Permits | 4 |
| 1.4 Available Existing Infrastructure | 4 |
| 2 GEOTECHNICAL STUDY | 5 |
| 3 WATER SERVICES | 6 |
| 3.1 Design Criteria | 6 |
| 3.2 Adequacy of Supply for Domestic and Fire Flows | 7 |
| 3.3 Check of High Pressures | 8 |
| 3.4 Reliability Requirements | 8 |
| 3.5 Summary and Conclusions | 8 |
| 4 SANITARY SERVICING | 8 |
| 4.1 Background and Existing Infrastructure | 8 |
| 4.2 Review of Ground Water and Soil Conditions | 8 |
| 4.3 Proposed Servicing and Calculations | 8 |
| 4.4 Summary and Conclusions | 9 |
| 5 STORM SERVICING AND STORMWATER MANAGEMENT | 9 |
| 5.1 Background | 9 |
| 5.2 Storm Servicing Strategy including Analysis of Existing Infrastructure | 9 |
| 5.3 Proposed Storm Servicing | 9 |
| 5.4 Grading | 16 |
| 5.5 Erosion and Sediment Control | 16 |
| 6 CONSTRUCTABILITY OF SERVICES | 16 |
| 7 CONCLUSIONS | 17 |
| 8 APPENDICES | 18 |

1 Introduction

1.1 Site Description and Proposed Development

This report describes the site servicing and stormwater management design and calculations pertaining to the new 5 storey Ottawa Public Library – Library and Archives Canada (OPL-LAC) Joint Facility to be constructed at 555 Albert Street.

The OPL-LAC Joint Facility is one the first components of the City of Ottawa’s Lebreton Flats Redevelopment. The building will house, in a shared facility, a new Ottawa Central Library and Library and Archives Canada’s public programs and services. The new building will play an integral role in facilitating a rich public experience of the joint programming and services offered. The new facility will include a shared outdoor space on the south side of the building for various programs and activities.

The existing site consists of a mix of gravel and other hard surfaces. It served as a one of the Stage 1 light rail transit (LRT) project’s construction site office and lay-down areas, and served a similar purpose for the Combined Sewage Storage Tunnel (CSST) project.

Existing infrastructure in the vicinity of the site is described in **Section 1.4** below.

The existing grading of the site generally slopes to the west from Albert St towards the Fleet St aqueduct, which runs parallel to the site. The Stage 1 LRT project constructed a cut and cover tunnel adjacent to the western edge of the site from approximately the Brickhill St right-of-way (ROW) to Commissioner St. The CSST project constructed a tunnel crossing beneath the site, from approximately the northeast to the southeast corner, using a tunnel boring machine.

Design drawings for proposed site servicing, grading, and erosion control are provided in **Appendix A**.

The format of this report matches that of the development servicing study checklist found in Section 4 of the City of Ottawa’s Servicing Study Guidelines for Development Applications. A completed copy of the checklist is provided in **Appendix I**.

1.1.1 Statement of Objectives and Servicing Criteria

The objective of this design brief is to demonstrate that the proposed design meets the servicing requirements for the proposed development, while adhering to the appropriate regulatory requirements.

1.1.2 Location Map and Plan

The location of the site is illustrated in **Figure 1**. A detailed site layout is illustrated on the drawings in **Appendix A**.

The OPL-LAC site is entirely within a property parcel owned by the City of Ottawa, located in Ward 14.

Figure 1 - Key Plan

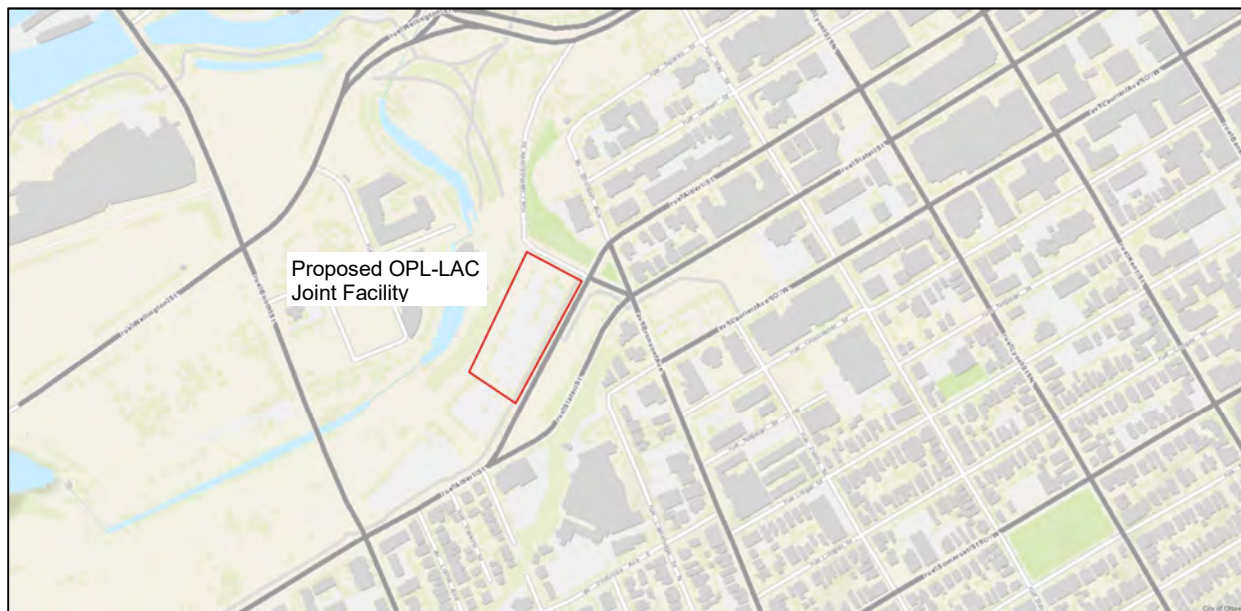

1.2 Background Documents

Existing conditions are shown on the Topographic and Legal Survey (**Appendix E**).

Documents reviewed in preparing this servicing brief include:

- Servicing and Stormwater Management Report, 557-584 Wellington Street & 550 Albert Street, Stantec Consulting Ltd., September 11, 2017.
- ISD Project Charter, 2017 Integrated Road, Sewer and Watermain Program Project Scoping Report, City of Ottawa, January 25, 2019
- Water Distribution System District Plan #366-030, City of Ottawa, 2018
- Sewer Collection System District Plan #366-030, City of Ottawa, 2019
- Utility Coordinating Committee drawing showing project site, City of Ottawa, 2019
- Fleet Street Pumping Station Discharge Piping, Commissioner Street and Bronson Avenue Watermains, Drawing #98-310-04, Delcan, January 2011
- Fleet Street Pumping Station Discharge Piping, Commissioner Street and Bronson Avenue Watermains, Drawing #98-310-07, Delcan, January 2011
- Lemieux Island Transmission Main Replacement Program, High Pressure Transmission Main, City Centre Avenue to Commissioner Street, Drawing #063018-C17, Robinson Consultants, August 2010
- Lemieux Island Transmission Main Replacement Program, High Pressure Transmission Main, City Centre Avenue to Commissioner Street, Drawing #063018-C18, Robinson Consultants, August 2010
- Albert Street Reconstruction, Grading & Drainage, Drawing #P6, Robinson Consultants, April 2015
- Albert Street Reconstruction, Grading & Drainage, Drawing #P6A, Robinson Consultants, April 2015
- Ottawa Combined Sewage Storage Tunnel, Drawing #PP1, Stantec/CH2M Hill, June 2016

- Ottawa Combined Sewage Storage Tunnel, Drawing #1B-C104, Stantec/CH2M Hill, June 2016
- Eastwest Bikeway From Laurier Avenue and Bay Street to Albert Street Crossing, Grading & Drainage, Drawing #010, Robinson Consultants, January 2016
- Untitled drawing showing existing sewers on Albert Street, Ref. A3-4, City of Ottawa, July 1935
- Ottawa LRT – 1800mm Sewer Inspection, Project #61000197, OLRT Constructors, July 2013
- Ottawa LRT West Portal Excavation Plan View, Drawing #OLR-20-2-WPTU-DRK-0001, OLRT Constructors, July 2013

1.3 Consultation and Permits

1.3.1 Pre-consultation Meetings

A pre-consultation meeting was held with representatives of the City of Ottawa and the consultant design team on April 23rd, 2020. Comments pertinent to this report are as follows:

- The City requires post-development flows from the site to be restricted to the 1:5 year pre-development level for all storm events up to and including 1:100 year storm.
- Pre-development flow to be calculated using the smaller of a runoff coefficient of 0.5 or the actual existing runoff coefficient. Use either a T_c of 20 minutes or calculated the pre-development T_c but not less than 10 minutes.
- Consult with the RVCA regarding storm water quality control requirements/restrictions.

The full comments regarding site servicing and stormwater management requirements can be found in **Appendix G**.

1.3.2 Adherence to Zoning and Related Requirements

The site is currently zoned MD H (40) – Mixed-Use Downtown Zone and is subject to Mature Neighborhoods Overlay.

1.4 Available Existing Infrastructure

Sewer and watermain mapping collected from the City of Ottawa indicate that the following infrastructure exists in and surrounding the subject site.

Commissioner Street

- 1520mm diameter Conc. high pressure transmission watermain (HPWM)

Albert Street

- 1220mm diameter STC HPWM
- 675mm diameter Conc. storm sewer
- 525mm diameter Conc. combined sewer
- 375mm diameter Conc. combined sewer
- 450mm diameter PVC sanitary sewer (south of Brickhill)

Brickhill Street

- 406mm diameter PVC watermain
- 300mm diameter PVC sanitary sewer

In addition, the Combined Sewer Storage Tunnel (CSST) and the Interceptor Outfall Sewer (IOS) both run within the bedrock below the proposed site.

Refer to **Figure 2** below indicating the existing infrastructure.

Figure 2 - Existing Infrastructure

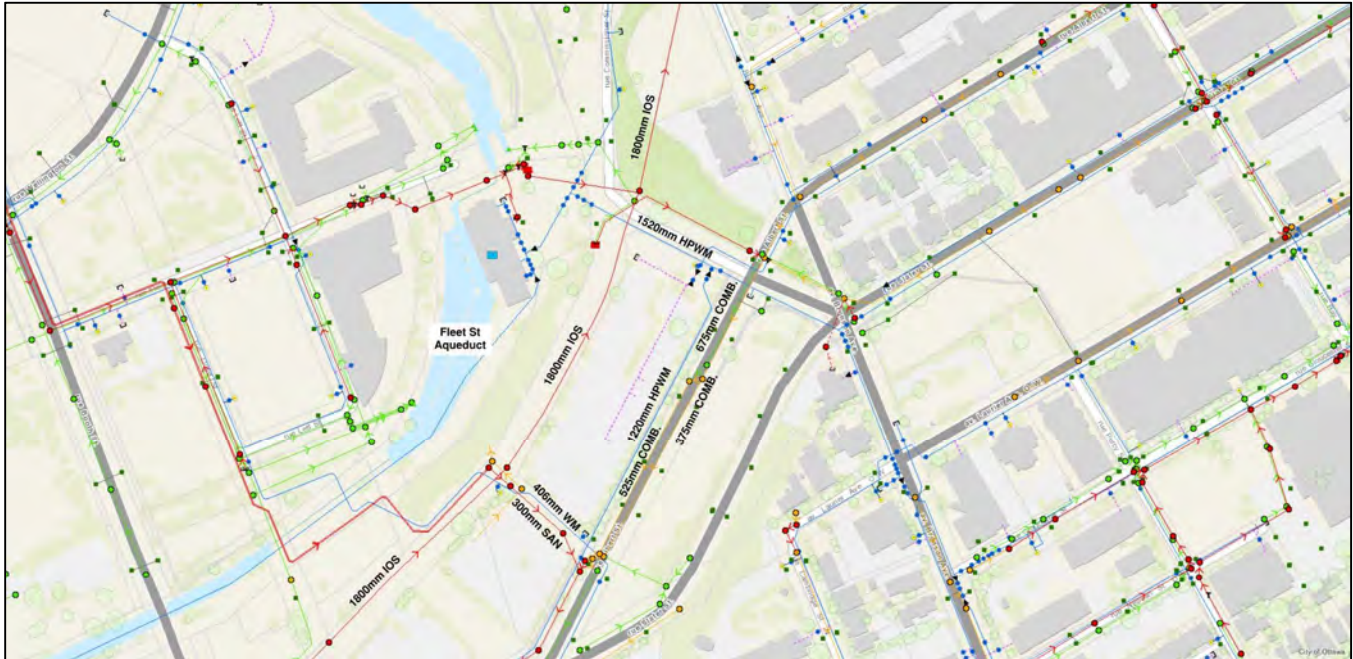

Existing infrastructure and utilities are shown in detail on Plan C800 found in **Appendix A**.

Reconstruction of Albert St is under design by the City, and will include replacement of the existing combined sewers within Albert St with separated storm and sanitary sewers as well as a new 200mm diameter watermain. Construction of Albert St is currently planned to be completed prior to the completion of the OPL-LAC Joint Facility.

2 Geotechnical Study

A Geotechnical Investigation was undertaken by Golder Associates and is documented in the Draft Report No. 19131600 dated February 2020.

Eighteen boreholes were drilled to a depths varying between 0.7m and 8.2m below the existing ground surface. The subsurface profile at the borehole locations within the area of the investigation consist of a surficial fill materials overlying glacial till. The fill is heterogeneous in nature and consists of gravelly sand, to gravelly silty sand, to silty sand, to sand and gravel, to sand, and contains brick fragments, concrete fragments, pockets of silty clay, ash, and cobbles and boulders. The fill was underlain by glacial till at depths of 1.4 to 3.7m below grade. Bedrock depth varies between 4.2m – 13.4m below existing grade.

Based on available geological mapping, the subject site is located in an area where the bedrock consists of interbedded limestone and shale of the Verulam formation.

Groundwater was encountered at depths of 2.0-5.7 m below the existing ground surface.

Recommendations regarding the installation of water and sewer services provided in the geotechnical report will be incorporated into the contract specifications.

3 Water Services

3.1 Design Criteria

The water service is designed in accordance with the 2010 City of Ottawa Water Design Guidelines (including Technical Bulletins) as well as MOE Design Guidelines for Drinking Water Systems. The proposed development lies within the City of Ottawa 1W pressure zone as shown by the Pressure Zone map in **Appendix C**.

The required domestic water demand and pressure design parameters for the new building have been calculated based on the criteria summarized in **Table 1**:

Table 1– Summary of Water Demand Parameters

| Design Parameter | Value |
|---|--|
| Average Daily Demand | 28000 L/gross ha/d ¹ |
| Max. Daily Peaking Factor | 1.5 x Average Daily ² |
| Max. Hourly Peaking Factor | 1.8 x Maximum Daily ² |
| Minimum Depth of Cover | 2.4m from top of watermain to finished grade |
| Desired pressure range during normal operating conditions | 350kPa and 480kPa |
| Min. pressure during normal operating conditions | 275kPa |
| Max. pressure during normal operating conditions | 552kPa |
| Min. pressure during maximum hourly demand | 276kPa |
| Min. pressure during maximum daily demand + fire flow | 140kPa |

¹ Daily average based on Appendix 4-A from Water Supply Guidelines
² Residential Max. Daily and Max. Hourly peaking factors per MOE Guidelines for Drinking-Water Systems Table 3-3 for 0 to 500 persons

Table 2 summarizes the water demand/fire flow for the development based on the **Ottawa Design Guidelines (2010 - including Technical Bulletins)** and the **Fire Underwriters Survey (1999 – as clarified by City Technical Bulletin ISTB 2018-02)**:

Table 2– Summary of Water Demand Calculations

| Design Parameter | Water Demand (L/s) |
|------------------------------------|-------------------------------|
| Average Daily Demand | 0.32 (27.2 m ³ /d) |
| Maximum Daily Demand | 0.48 |
| Maximum Hourly Demand | 0.87 |
| Fire Flow | 233 |
| Total Max Daily Demand + Fire Flow | 234 |

Domestic and fire flow calculations are provided in **Appendix B**. Supporting correspondence from the Architect regarding the characteristics of the new building is also provided in **Appendix B**.

The Mechanical engineer has confirmed that a fire pump rated for 1000 GPM (63 L/s) will be installed within the building.

3.2 Adequacy of Supply for Domestic and Fire Flows

The building will be serviced from the future 200mm diameter Albert St watermain, currently under design by others. The minimum pressure in this watermain under the Max Day Demand + fire, Maximum Hourly, and Max day scenarios have been determined based on boundary conditions received from the City of Ottawa. A copy of the correspondence and boundary conditions is provided in **Appendix B**.

A 200mm diameter water service connection has been determined to meet applicable requirements.

A summary of the demands and performance of the proposed 200mm diameter water service is provided in **Table 3**.

Table 3– Summary of Water Servicing Design Parameters/Calculation Results

| | Scenario | | | Source of Data |
|---|----------------|------------|---------|---|
| | Max Day + Fire | Max Hourly | Max Day | |
| Flow Demand (L/s) | 233.81 | 0.87 | 0.48 | Calculated for OPL-LAC |
| Boundary Condition: Available Pressure under Future Conditions (kPa) | 309.02 | 397.31 | 397.31 | Provided by City of Ottawa for 200mm Watermain ¹ |
| Residual Pressure at Service Tee including pipe losses (200mm diameter pipe) (kPa) | 229.97 | 397.27 | 397.28 | Calculated for OPL-LAC |
| Minimum Allowable Pressure (kPa) | 140 | 276 | 345 | City of Ottawa Water Design Guidelines |
| ¹ The City of Ottawa Boundary Conditions for 200mm water service assumed to be connected to future 203mm water main, subsequent pressure measured from finished floor elevation (66.5m). | | | | |

The number of available fire hydrants within proximity of the building was analyzed in accordance with Technical Bulletin ISTB-2018-02 dated March 21, 2018, Appendix I. The following table demonstrates that the fire flow (calculated by the FUS method) can be provided by hydrants within 150m of the building.

Table 4 – Availability Fire Flow from Hydrants

| Building | Fire Flow Demand (L/min) | Fire Hydrant(s) within 75m | Fire Hydrant(s) within 150m | Combined Fire Flow (L/min.) |
|----------|--------------------------|----------------------------|-----------------------------|-----------------------------|
| OPL-LAC | 14,000 | 3 | 1 | 20,900 |

A figure showing the location of these hydrants is provided within the fire flow calculations in **Appendix B**.

The primary fire hydrant is located within 45m of the proposed siamese connection (fire department connection), which is located immediately southeast of the main building entrance on Albert St.

A booster pump is required to be designed and installed by the Mechanical engineer as the minimum pressure is not met under the maximum hourly flow condition at the roof elevation of 91.9m.



3.3 Check of High Pressures

The site is within Pressure Zone 1W, which operates at a maximum head of 115 m (City of Ottawa Water Master Plan, 2013). This would result in a maximum pressure above the finished floor elevation of approximately 476kPa, which falls under the maximum 552kPa defined in the guidelines.

3.4 Reliability Requirements

Because the average daily demand is equal to 27.2 m³/d and does not exceed 50 m³/d, dual service connections are not required for the building.

3.5 Summary and Conclusions

The proposed building will be serviced by a 200mm diameter water service connected to the new 200mm diameter watermain (under design by others) that will be installed in Albert St.

4 Sanitary Servicing

4.1 Background and Existing Infrastructure

The sanitary service design is in accordance with the 2012 Ottawa City Sewer Design Guidelines. Existing sanitary infrastructure is described in detail in **Section 1.4**. The site will be serviced by separated storm and sanitary sewers (under design by others) that will be installed in Albert St.

4.2 Review of Ground Water and Soil Conditions

Recommendations regarding the installation of piped services that are provided in the geotechnical report will be incorporated into the contract specifications.

Refer to correspondence with Golder Associates in **Appendix H** in regards to groundwater and soil conditions.

4.3 Proposed Servicing and Calculations

The proposed building will require a new 250mm diameter PVC sanitary service. The new 250mm diameter PVC sanitary service will extend from the south side of the building and connect to an existing 300mm diameter sanitary sewer in Brickhill St. The 300mm diameter sewer in Brickhill St was installed in 2019 as part of the Zibi Development project, an as-built drawing of this sewer can be found in **Appendix F**. The sanitary servicing design parameters are summarized in **Table 5**.

Table 5– Summarization of Sanitary Servicing Design Parameters

| Design Parameter | Value |
|---|--|
| Gross Area | 0.97 ha |
| Commercial Average Flow | 28,000 L/ha/day |
| Commercial Peaking Factor | 1.5 |
| Infiltration and Inflow Allowance | 0.28 L/ha/s |
| Sanitary Sewer Sizing Based on the Manning's Equation | $Q = \frac{1}{n} \pi AR^{2/3} S^{1/2}$ |
| Manning's Coefficient 'n' | 0.013 |
| Minimum Depth of Cover | 2.5m from obvert of sewer to grade |
| Minimum Full Flowing Velocity | 0.6m/s |
| Maximum Full Flowing Velocity | 3.0m/s |
| <i>Note: As per Sections 4 and 6 of the City of Ottawa Sewer Design Guidelines, October 2012 incl. all Tech. Bulletins as of November 2019.</i> | |

The proposed building will produce a sanitary flow of 0.31 L/s as calculated per the City of Ottawa 2012 Sewer Design Guidelines. The proposed 250mm PVC service lateral (at 2.0% slope) has a maximum capacity of 84.0 L/s. This is sufficient for the calculated sanitary flow.

The existing 300mm separated sanitary sewer on Brickhill St has sufficient capacity accommodate this calculated flow. Calculations are provided in **Appendix D**.

4.4 Summary and Conclusions

The proposed building will be serviced by a 250mm diameter PVC sanitary service that has been determined to meet all required servicing constraints and associated design criteria/requirements.

5 Storm Servicing and Stormwater Management

5.1 Background

The existing drainage pattern of the site is overland to the west, across the LRT tunnel and towards the aqueduct leading to the Fleet Street Pumping Station. There are currently no stormwater quality or quantity control measures within the site.

The City of Ottawa's Sewer Design Guidelines require the 100-year post-development storm flow to be restricted to the 5-year pre-development runoff with an assumed pre-development coefficient no greater than 0.5.

For the proposed development, quantity control meeting the City of Ottawa requirements is proposed to be provided through the use of on-site detention. Flow control is to be provided by a stormwater pumping station with a design flow equal to the calculated allowable release rate.

5.2 Storm Servicing Strategy including Analysis of Existing Infrastructure

The stormwater management design has been completed by restricting the 100-year post-development flow to the 5-year pre-development runoff (calculated at a pre-development runoff coefficient of 0.5) to meet the capacity of downstream sewers. The 100-year flow will be detained on site. The required underground storage volume has been calculated using the Modified Rational Method.

During design development, opportunities to utilize low impact development technologies were explored. The following items have been incorporated in the design:

- 2200 m² green roof.
- Reduction of impermeable surfaces in landscaped areas.

5.3 Proposed Storm Servicing

Proposed storm servicing is indicated on Drawing C001 in **Appendix A**. The proposed pre-development and post-development catchment areas, runoff coefficients and catchment total areas are indicated on the Drainage Area Plans, also in **Appendix A**.

5.3.1 Design Criteria (Minor and Major Systems)

For the design of stormwater management (SWM), the City of Ottawa's criteria for a Commercial/ Institutional/ Industrial development in an existing area will be applied (Section 8.3.7.3 of the City of



Ottawa Sewer Design Guidelines), except where modified as described in the following summary of the City's key SWM requirements:

- On-site SWM measures required to avoid impact on downstream system (i.e. existing storm sewers).
- Runoff to be controlled to the 5-year pre-development level.
- Pre-development flow to be calculated using the smaller of a runoff coefficient of 0.5 or the actual existing runoff coefficient. Use either a T_c of 20 minutes or calculated the pre-development T_c but not less than 10 minutes.
- All flow depths must be controlled on-site (i.e. no spill to adjacent properties or rights-of-way for flows up to the 100-year event).
- The design should consider the 100-year return period event, address performance for specified historical storms, and be stress tested for Climate Change using design storms calculated on the basis of a 20% increase of the City's IDF curves for rainfall events. Any instances of severe flooding identified through the stress test must be rectified.

Key drainage design requirements from the City of Ottawa Sewer Design Guidelines include:

- The minor system (underground storm sewers) is designed to capture the 5-year event (minimum). Inlet Control Devices should be utilized to minimize surcharging during the 100-year event.
- The minor system is designed to convey the 5-year event, with the hydraulic grade line (HGL) below the crown of the pipe (except where impacted by boundary conditions – in which case the HGL shall not exceed 0.3m below the underside of the footings during the 100-year event).
- For events greater than the 100 year return period, spillage should not be directed to neighbouring private property.
- The site grading ensures that the property being developed is higher than the spill elevation of the adjacent municipal ROW. This is considered especially critical if underground parking is being proposed. The grading ensures sufficient positive drainage away from the building, with a minimum slope from the building to the street of 2% and building openings a minimum of 0.3m above the 100-year ponding level. If reduced lot grading is considered for an increase in travel time and infiltration, the 2% minimum grade is still maintained for at least 4m from the building.
- The maximum water depth on streets (public, private and parking lots), static or dynamic, is 350 mm.
- Where underground storage is utilized, the design must ensure that backwater from the downstream system does not impact the required storage.

In addition to the City of Ottawa's guidelines, requirements for storm water quality control have been considered. The Rideau Valley Conservation Authority (RVCA) was contacted for input, and confirmed that stormwater quality control is not required for this site. Correspondence with the RVCA is provided in **Appendix G**.



5.3.2 Stormwater Quantity Control

5.3.2.1 Runoff Coefficient and Peak Flows

Table 6 indicates the runoff coefficient for each catchment. The 100-year runoff coefficients include a 25% increase (to a maximum of 1.0) as required by the City of Ottawa Sewer Design Guidelines Section 5.4.5.2.1.

Table 6– Pre-development Runoff Coefficients (development area)

| Storm Event | Pre-Development Runoff Coefficients | |
|--------------------|-------------------------------------|----------------|
| | 5-Year Storm | 100-Year Storm |
| Areas Description | A1 | A1 |
| Site Area (in ha) | 0.97 | 0.97 |
| Runoff Coefficient | 0.65 | 0.81 |

Intensity (i) is calculated using the formula:

$$i = \frac{A}{(T_d + C)^B}$$

Where A, B and C are all factors of the IDF Return Period, T_d being the time of concentration and A the drainage area (Detailed calculations provided in **Appendix E**).

Time of concentration is determined using the inlet time graph (Appendix 5D Ottawa City Sewer Design Guidelines) which results in a value of 10 minutes. With the pre and post-development runoff coefficients and rainfall intensity, the peak flows for each drainage area can be calculated using the Rational Method. The results (using actual runoff coefficients) are summarized in **Table 7**.

Table 7– Pre-Development Peak Flows

| Return Period (Years) | Pre-Development Peak Flows (actual runoff coefficients) | | | |
|-----------------------|---|-----------|--------------------------------|----------------------|
| | Intensity, I (mm/hr) | Area (ha) | Runoff Coefficient, R (Note 1) | Runoff Rate, Q (L/s) |
| 2 | 76.8 | 0.97 | 0.65 | 134.6 |
| 5 | 104.2 | 0.97 | 0.65 | 182.6 |
| 100 | 178.6 | 0.97 | 0.81 | 391.2 |

Note 1: For 100-year event, Runoff Coefficient is increased by 25% to a maximum of 1.0.

To calculate the allowable release rate, the following criteria are applied:

| | | |
|----------------------------|-----|---------|
| Return Period | 5 | year |
| Maximum Runoff Coefficient | 0.5 | |
| Time of Concentration | 10 | minutes |

Table 8– Allowable Release Rate

| Return Period (Years) | Intensity, I (mm/hr) | Area (ha) | Runoff Coefficient, R | Runoff Rate, Q (L/s) |
|-----------------------|----------------------|-----------|-----------------------|----------------------|
| 5 | 104.2 | 0.97 | 0.50 | 140.5 |

The allowable release rate for the site has been calculated to be 140.5 L/s.



The project will result in Area A1 being partially covered with impervious surfaces. The post-development runoff coefficients are indicated in **Table 9**:

Table 9– Overall Post-Development Runoff Coefficients

| Storm Event | Overall Post-Development Runoff Coefficients | |
|------------------------------------|--|----------------|
| | 5-Year Storm | 100-Year Storm |
| Areas Description | A1 | A1 |
| Project Area (in ha) | 0.99 | 0.99 |
| Weighted Runoff Coefficient | 0.72 | 0.89 |

The increase in total area is a result of building roof overhang along Albert St.

5.3.2.2 Stormwater Management Concept

Uncontrolled Drainage Areas (B1, B2, B3)

It is not feasible to capture runoff from the proposed loading area along Commissioner Street (Area B1) as a result of the large distance to the proposed storage tank, and due to conflicts internal to the building which make running a pipe by gravity not feasible. Due to the nature of the grading in the loading area, runoff will be captured via a trench drain and catch basins and directed into the building where it will be pumped to STMH02 and ultimately released uncontrolled to the storm sewer on Albert St. Refer to mechanical for internal pumping design and to **Appendix H** for correspondence.

In addition, due to the large elevation difference it is not feasible to capture runoff from the sloped planted area on the west side of the site (Area B2). The runoff from this area will be overland to the west towards the existing Fleet Street aqueduct.

Lastly, it is not viable to control runoff from the setbacks along Albert St (Area B3), as such these areas will release uncontrolled to the Albert St ROW.

Table 10 provides a summary of the characteristics of the uncontrolled areas.

Table 10– Post-Development Uncontrolled Release

| Storm Event | Post-Development Uncontrolled Release | |
|--------------------|---------------------------------------|----------------|
| | 5-Year Storm | 100-Year Storm |
| Drainage area (ha) | 0.167 | 0.167 |
| Runoff Coefficient | 0.76 | 0.92 |
| Peak Flow (L/s) | 36.9 | 76.3 |

The allowable release rate is therefore calculated to be **64.2 L/s**, by subtracting the peak flow from the uncontrolled areas from the pre-development allowable release rate that was calculated to be 140.5 L/s.

Controlled Drainage Areas BLDG, A1, A2, A3 and A4

The drainage from the roof (BLDG) and the landscaped areas at the south side of the proposed building (A1, A2, A3, and A4) will be captured and directed to an underground storage tank located below the proposed amphitheater plaza to the south of the building. A 0.22ha green roof is included in the roof area. The runoff coefficient for this area was taken as 0.5 as detailed in Section 4.2 of the Low Impact Development Stormwater Management Planning and Design Guide, CVC, 2011. Area A1 also includes the upper terrace which extends around the north-west side of the building.



Stormwater will outlet from the tank into a pumping station located next to the proposed building as described in **Section 5.3.3** below. The pumping station will control the release rate from the tank to meet the allowable release rate as indicated above. Under these circumstances the release rate from the tank will remain constant and the drawdown of the tank (and associated variation in static head) will not have an effect on the tank sizing.

As indicated by the proposed storage calculations, the required underground storage for the tank is 157m³. It is proposed that the tank will be a rectangular plastic geocellular stormwater storage tank (or approved equivalent). Assuming a void ratio of 0.97 (as per documentation for a typical tank in **Appendix D**), appropriate tank dimensions are 18.0m long by 5.0m wide by 1.8m tall.

Summary

Table 11 summarizes the proposed release rates and confirms that the total release rate does not exceed the allowable release rate.

Table 11 – Post-Development Controlled Peak Flows

| | Post-Development Controlled Peak Flows (L/s) |
|---|--|
| Allowable Release Rate | 140.5 |
| Release Rate from Uncontrolled Drainage Areas | 76.3 |
| Release Rate from Controlled Drainage Areas | 64.2 |
| Total Release Rate | 140.5 |

5.3.2.3 Impact on Existing Stormwater Infrastructure

Overall runoff from the site to the storm sewers will be significantly reduced by the proposed development:

Table 12 – Pre-Development Peak Flows vs. Post-Development Controlled Peak Flows

| | Pre-Development Peak Flow | Post-Development Controlled Peak Flow |
|--------------------|---------------------------|---------------------------------------|
| Storm Event | 5-Year Storm | 5-Year Storm |
| Total runoff (L/s) | 182.6 | 140.5 |

Design calculations for the new storm service are provided in **Appendix D**.

5.3.3 Pumping Station Design

Through the design process it was determined that the existing Albert St HPWM is in direct conflict with the elevation range where a gravity storm connection to the new Albert St storm sewer (under design by others) would be feasible. It was therefore concluded that a gravity storm service from the proposed stormwater management tank would not be feasible, and that a pumping station is required.

The pumping station is proposed to be a Xylem TOP pre-engineered and factory built fiberglass pumping station (or approved equivalent). Refer to **Appendix D** for details from the manufacturer. The pumping station controls will be located within a cabinet accessible from the outside of the building within eye sight of the pump station. Refer to the site servicing plan in **Appendix A** for the pumping station and controls location, including the notes specific to the pump station requirements.



The pumping station is designed to control the flow out of the tank to the allowable release rate as determined in **Section 5.3.2**. A dual pump system will be installed for redundancy with each pump designed for the duty point outlined in **Table 13**.

Table 13– Summarization of Pumping Station Design Parameter

| Design Parameter | Value |
|------------------------|----------------------------------|
| Require Rated Capacity | 0.064 m ³ /s (64 L/s) |
| Total Dynamic Head | 6.46 m |

To achieve the proposed ultimate capacity of 64 L/s a single pump will be installed with a single 200mm forcemain. A second pump will be installed as a stand-by. **Figure 3** shows the proposed pump curves overlaid on the system curves. A forcemain C value of 130 is assumed for the system curves. The manufacturer’s curves for the proposed pumps (Flygt N 3153 LT 3 submersible pumps) are provided in **Appendix D**.

Figure 3 - Proposed Pump and System Curves

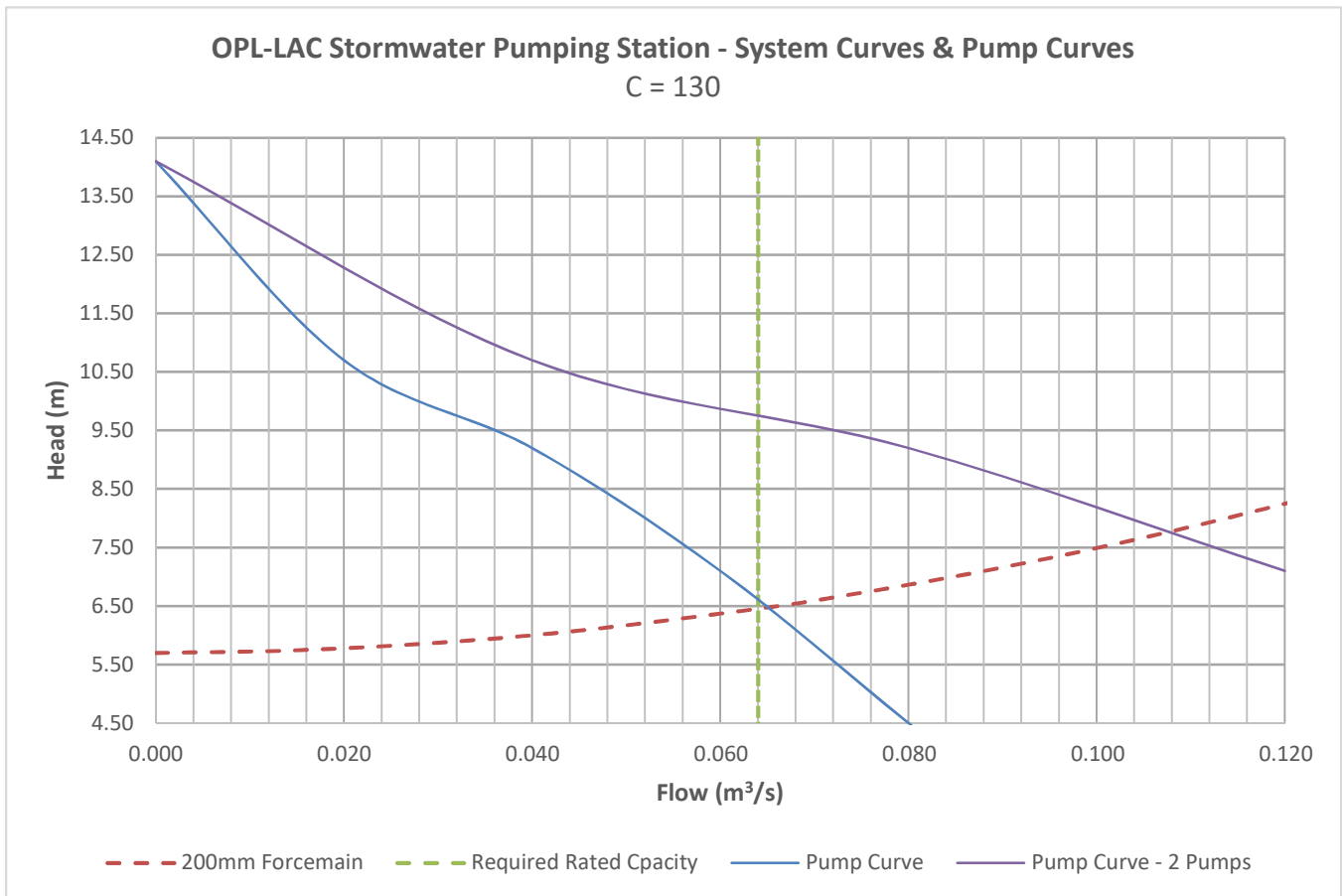

Refer to **Appendix D** for pumping station design calculations.



5.3.4 Commissioner Street Major Flow Analysis

In order to demonstrate that overland drainage on Commissioner Street does not impact the loading dock area, a rational method analysis was conducted to estimate the major flow along Commissioner Street.

A single catchment area was defined based on existing topography. It was determined that a portion of Albert St drains onto Commissioner St; this area was included in the catchment area. The peak flow was calculated as the difference between the 100-year and the 2-year storms, assuming the catch basins on Albert St and Commissioner St have 2-year capacity. This gives a peak flow on Commissioner St during the 100-year storm of 258.8 L/s.

A hydraulic analysis of Commissioner St was conducted using the modeling software Hydraulic Toolbox. Using a cross-section of the west end of this section of Commissioner St, the flow depth during the peak flow condition was determined to be 0.07m. It can thus be concluded that there is positive drainage from the sidewalk to Commissioner Street. A peak major flow would not overtop the curb and sidewalk, and therefore would not impact ponding levels in the loading dock area. Details of this calculation are provided in **Appendix D**.

5.3.5 Storm Water Quality Control

As per **Section 5.3.1** above, it was confirmed that the RVCA does not require quality control for this project. Correspondence is provided in **Appendix G**.

5.3.6 Pre-Consultation with the Ontario Ministry of the Environment and Conservation and Parks, and Conservation Authority

The Ministry of Environment, Conservation and Parks (MECP) was contacted for input, and confirmed that an ECA is not required for the site. Correspondence is provided in **Appendix G**.

5.3.7 Minor and Major Systems

The minor storm servicing system consists of the sewers described above, and as indicated on the design drawings provided in **Appendix A**.

The major system consists of flow west to the existing Fleet Street Aqueduct. To the extent possible, the site will be graded to direct runoff from storms in excess of the 100-year event to the adjacent Albert and Commissioner St ROWs, although for most of the site this is not possible due to topography and the finished floor elevation of doors into the new building. Runoff in excess of the 100-year event will flow west over top of the LRT tunnel towards the aqueduct, from where flow will continue towards the Ottawa River.

5.3.8 Impacts to Receiving Watercourses

No negative impacts to receiving watercourses are anticipated.

5.3.9 100 Year Flood Levels and Major Flow Routing

The site is not within a 100-year floodplain. A figure of the Ottawa river floodplain overlay extracted from the City's GeoOttawa resource is included in **Appendix D**.



5.4 Grading

The proposed grading plan is shown in Drawing C003 in **Appendix A**. The development will be tied into the existing grade of Commissioner St.

It is anticipated the construction of the OPL-LAC Joint Facility will occur within the same timeline as the Albert Street Reconstruction project (currently under design by others). Coordination regarding the future grade of Albert Street along the OPL-LAC Joint Facility frontage is currently in progress with the Albert Street Reconstruction project team.

Final Albert St design grades will be confirmed and coordinated with the grading of the area adjacent to the new OPL-LAC building along the Albert Street frontage, to ensure positive drainage away from the building is provided.

5.5 Erosion and Sediment Control

As described in the servicing guidelines, an erosion and sediment control plan is required for implementation during the construction phase. To minimize the migration of sediments, measures such as silt fencing and sediment capture devices for catch-basins downstream of the site and around the building are to be installed to capture and retain sediment. Additionally, all stockpiles are to be covered.

During construction, all erosion control features shall be maintained and repaired as necessary and adjacent roadways kept free of construction debris and sediment this responsibility falls under the prevue of the Contractor.

Refer to **Appendix A** for a copy of the proposed erosion and sediment control plan.

6 Constructability of Services

The purpose of this section is to provide a brief overview of the constructability of the new building services.

The water and storm services are proposed to be connected to the new watermain and storm sewer that will be installed within Albert St (currently under design by others). It is proposed that both services cross over top of the Albert St HPWM in order to avoid increased construction complexity, risk, and costs that would be associated with installing the services beneath the City's watermain.

A storm forcemain will be installed from the outlet of the pumping station to a storm maintenance hole located within the OPL-LAC site. From this maintenance hole, a gravity storm service will continue and connect to the new Albert St storm sewer. The depth of cover on a portion of the forcemain and gravity service is less than the required 2m. As such, insulation will be provided in accordance with City standards. The new water service is also to cross over top of the HPWM. A depth of cover of 2.4m is required to water infrastructure per City standards. This depth of cover cannot be provided at the HPWM crossing, so insulation will be provided in accordance with City standards.

The sanitary service is proposed to connect to an existing sanitary maintenance hole within Brickhill St. The subject Brickhill maintenance hole was installed as part of the Zibi Development. In order to accommodate a required change in horizontal alignment of the new sanitary service, to intersect the existing maintenance hole and avoid major proposed landscaping elements above, a new sanitary maintenance hole is proposed within the OPL-LAC site adjacent to the Brickhill ROW.



7 Conclusions

In conclusion the proposed development meets all required servicing constraints and associated design criteria/requirements as well as the additional City of Ottawa requirements identified in the pre-consultation phase. It is recommended that this report be submitted to the City of Ottawa in support of the application for site plan approval.

Sincerely,

Morrison Hershfield Limited



James Fookes, P.Eng., C.Eng.
Senior Municipal Engineer



Bryan Kipp, P.Eng.
Municipal Engineer

8 Appendices

- Appendix A Site Servicing, Grading and Erosion and Sediment Control, Catchments Plans, Utilities Plans, and Details
- Appendix B Water Demand and FUS Calculations
- Appendix C Sanitary Flow Calculations
- Appendix D Storm Sewer Design Calculations
- Appendix E Topographic and Legal Survey
- Appendix F Relevant As-built Drawings
- Appendix G Regulatory Correspondence
- Appendix H Non-regulatory Correspondence
- Appendix I Checklist

Appendix A

Site Servicing, Grading and Erosion and Sediment Control, Catchments Plans, Utilities and Details

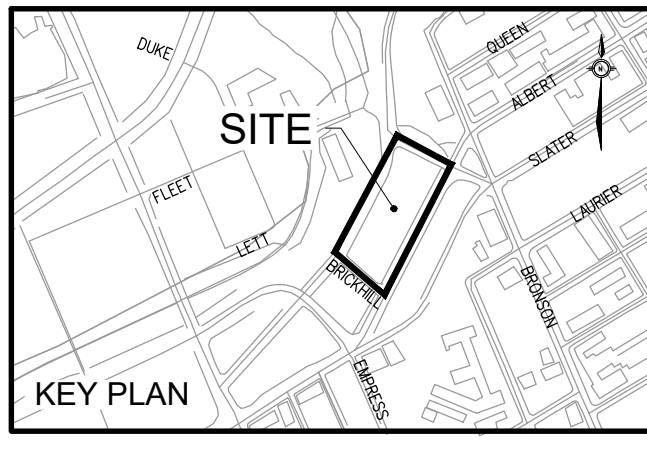

ISSUED

| No. | Date | Description |
|-----|----------|------------------------------|
| 0 | 05/06/20 | ISSUED FOR SITE PLAN CONTROL |

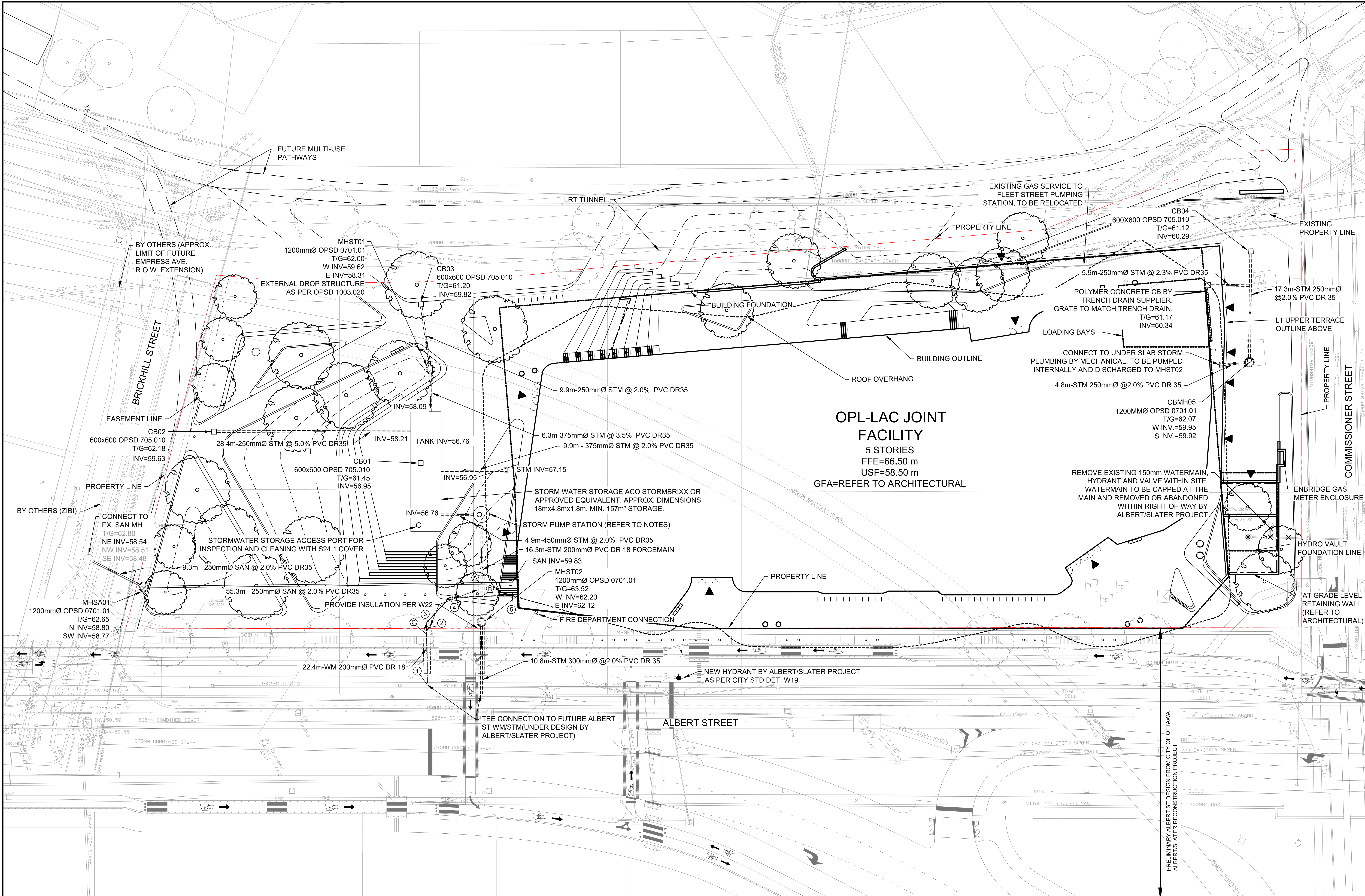

NOTES:
GENERAL

- COORDINATES ARE IN NTM ZONE 9 (76°30' WEST LONGITUDE) NAD-83 (ORIGINAL).
- OBTAIN ALL NECESSARY PERMITS AND APPROVALS FROM THE CITY OF OTTAWA PRIOR TO STARTING CONSTRUCTION.
- SERVICES ARE TO BE CONSTRUCTED TO 1.0m FROM FACE OF BUILDING.
- REFER TO "SITE SERVICING AND STORMWATER MANAGEMENT DESIGN BRIEF - OTTAWA PUBLIC LIBRARY - LAC JOINT FACILITY" PREPARED BY MORRISON HERSHFELD FOR SITE SERVICING REPORT.
- REFER TO GEOTECHNICAL INVESTIGATION REPORT (NO. 191316) DATED FEBRUARY 20, 2020 PREPARED BY GOLDER ASSOCIATE FOR SUBSURFACE CONDITIONS, CONSTRUCTION RECOMMENDATIONS AND GEOTECHNICAL INSPECTION REQUIREMENTS. THE GEOTECHNICAL CONSULTANT SHALL REVIEW EXCAVATIONS PRIOR TO THE PLACEMENT OF GRANULAR MATERIAL.
- CONTRACTOR TO VERIFY ALL EXISTING UTILITY ELEVATIONS AT CONNECTION AND CROSSING LOCATIONS PRIOR TO CONSTRUCTION AND ADVISE THE ENGINEER OF ANY DISCREPANCIES.
- UNLESS DIRECTED OTHERWISE ANY DAMAGED ASPHALT OR CURB (REGARDLESS OF WHETHER WITHIN OR EXTERNAL TO THE SITE) SHALL BE REINTEGRATED IN ACCORDANCE WITH CITY STD. DET. S11 AND S1.
- UNLESS DIRECTED OTHERWISE THE CONTRACTOR SHALL REINSTATE ALL SIGNS, LIGHTING AND OTHER STREET FURNITURE DISTURBED BY THE WORK.
- THE CONTRACTOR SHALL DEVELOP AND IMPLEMENT TRAFFIC MANAGEMENT PLANS FOR WORK IN RIGHT OF WAY IN ACCORDANCE WITH OTM BOOK 7.
- CLAY SEALS SHALL BE INSTALLED IN ACCORDANCE WITH CITY OF OTTAWA STANDARD DETAIL S8 AND SHALL BE INSTALLED AT 50m INTERVALS IN ALL PIPE TRENCHES. CLAY SEAL TO EXTEND FULL TRENCH WIDTH AND FROM BOTTOM OF TRENCH EXCAVATION TO UNDERSIDE OF ROAD STRUCTURE WITH A MINIMUM THICKNESS OF 15mm ALONG PIPE.
- LOCATE AND CAP ALL EXISTING STORM, SANITARY AND WATER SERVICES AT THE PROPERTY LINE. ABANDON EXISTING SERVICES WITHIN THE R.O.W. PER STANDARD CITY OF OTTAWA DETAIL S11.4 (TYPICAL).

SEWERS

- ALL STORM SEWERS, SANITARY SEWERS AND CATCH BASINS LEADS SHALL BE PVC DR 35 UNLESS OTHERWISE SPECIFIED.
- REFER TO DETAIL 1 ON DRAWING C005 FOR SEWER INSTALLATION.
- MAINTENANCE HOLES AND CATCH BASIN MAINTENANCE HOLES ON STORM SEWERS LESS THAN 800mm DIAMETER SHALL BE CONSTRUCTED WITH A 300mm SUMP. BENCHING SHALL BE INSTALLED IN MAINTENANCE HOLES ON STORM SEWERS 900mm AND ABOVE.

WATERMANS

- REFER TO DETAIL 1 ON DRAWING C005 FOR WATERMAIN INSTALLATION.
- ALL WATERMAIN MATERIALS AND CONSTRUCTION METHODS SHALL BE IN ACCORDANCE WITH THE 2019 EDITION OF THE CITY OF OTTAWA STANDARD SPECIFICATIONS AND STANDARD DRAWINGS. PVC PIPE TO BE CLASS 150 DR18 TO LATEST EDITION OF A.W.W.A. SPECIFICATION C900 AND C813.3 LATEST AMENDMENT WITH GASHEATED BELL AND SPOUT COUPLINGS.
- CONTRACTOR SHALL BE RESPONSIBLE FOR OBTAINING A WATER PERMIT AS REQUIRED FROM THE CITY OF OTTAWA, AND COMPLYING WITH ALL CITY OF OTTAWA REQUIREMENTS. THE CITY MAY REQUIRE THAT CERTAIN ACTIVITIES (E.G. VALVE OPERATION, CONNECTION OF NEW WATER SERVICE TO EXISTING WATERMAIN, DISINFECTION) BE CARRIED OUT ONLY BY CITY FORCES.
- ALL VALVES 300mm DIAMETER AND SMALLER SHALL INCLUDE A VALVE BOX AS PER W24.
- THE NEW WATERMAIN IS TO BE INSTALLED WITH A MINIMUM OF 2.4m COVER (INCLUDING HYDRANT LEAD), WHERE 2.4m COVER IS NOT POSSIBLE. PROVIDE INSULATION IN ACCORDANCE WITH CITY OF OTTAWA STANDARD DETAILS W22 & W23.
- THRUST RESTRAINT SHALL BE PROVIDED BY BOTH RESTRAINING/RETAINING RINGS AND THRUST BLOCKS AT ALL DEAD END CAPS, PLUGS, VALVES, BENDS AND REDUCERS AS PER CITY OF OTTAWA STANDARD DETAILS W23, W24, W25 & W26. ALL TEMPORARY THRUST RESTRAINTS ARE THE RESPONSIBILITY OF THE CONTRACTOR.
- TRACER WIRE SHALL BE PROVIDED FOR ALL NEW PVC WATERMANS IN ACCORDANCE WITH THE SPECIFICATIONS AND CITY OF OTTAWA STANDARD DETAIL W26.
- CATHODIC PROTECTION SHALL BE PROVIDED FOR ALL NEW WATERMANS IN ACCORDANCE WITH THE SPECIFICATIONS AND CITY OF OTTAWA STANDARD DETAILS W26, W40, W41, W42 AND W47. CATHODIC PROTECTION OF EXISTING WATERMANS SHALL ALSO BE PROVIDED AT CONNECTIONS BETWEEN EXISTING AND NEW WATERMANS.
- ADJUST ALL VALVE CHAMBERS, VALVE BOXES AND HYDRANTS TO FINISHED GRADE.

UTILITY NOTE

- THE POSITION OF POLE LINES, CONDUITS, WATERMANS, SEWERS AND OTHER UNDERGROUND AND OVERGROUND UTILITIES AND STRUCTURES IS NOT NECESSARILY SHOWN ON THE CONTRACT DRAWING AND, WHERE SHOWN, THE ACCURACY OF THE POSITION OF SUCH UTILITIES AND STRUCTURES IS NOT GUARANTEED. BEFORE STARTING WORK THE CONTRACTOR SHALL INFORM HISSELF OF THE EXACT LOCATION OF ALL SUCH UTILITIES AND STRUCTURES, AND SHALL ASSUME ALL LIABILITY FOR DAMAGE TO THEM. THE CONTRACTOR WILL BE RESPONSIBLE FOR SUPPORTING AND PROTECTING ANY EXISTING UTILITIES, AS REQUIRED, IN ACCORDANCE WITH THE UTILITY OWNERS' REQUIREMENTS. CONTRACTOR IS REQUIRED TO OBTAIN LOCATES IN ADVANCE OF EXCAVATION WORK AND FORWARD COPIES OF THE LOCATES TO THE CONSULTANT AND THE OWNER PRIOR TO EXCAVATION.
- ALL CROSSING OF EX. UTILITIES TO BE IN ACCORDANCE WITH CITY STD. DET. S10

STORMWATER PUMPING STATION

- REFER TO SPECIFICATIONS FOR ADDITIONAL REQUIREMENTS.
- SUBMIT SHOP DRAWINGS STAMPED BY PROFESSIONAL ENGINEER LICENSED TO PRACTICE IN ONTARIO.
- DUTY POINT: 64.0 LIS AT 6.46m HEAD
- T/D = 41.8m
- PUMP ON ELEVATION = 56.66m
- PUMP OFF ELEVATION = 56.84m
- INVERT = 56.5m
- MINIMUM INTERNAL DIAMETER = 1200mm
- DUTY/STANDBY PUMPS REQUIRED
- WET WELL TO BE PRECAST CONCRETE OR FRP
- ACCESS COVERS TO BE PER CITY ST. DET S24
- VENT FOR PUMP STATION SHALL BE CONNECTED TO THE VENT/LOUVER SYSTEM ON THE ADJACENT WALL OF THE NEW BUILDING. CONTRACTOR TO PROVIDE VENT TO THE FROM BUILDING AND INCLUDE AN ALLOWANCE IN COST ESTIMATE TO COVER COORDINATION WITH PUMP STATION MANUFACTURER AND MECHANICAL ENGINEER TO CONFIRM REQUIREMENTS OF VENT PIPE AND ROUTING.

PROPOSED WATER SERVICE TABLE

| NUMBER | SURFACE ELEVATION | T/W M ELEVATION | COMMENTS |
|--------|-------------------|-----------------|---|
| 1 | 62.99 | 60.59* | TEE CONNECTION TO FUTURE 200mmØ WATERMAIN |
| 2 | 63.22 | 60.82± | 200mmØ SHUT-OFF VALVE |
| 3 | 63.21 | 60.81± | 45° BEND |
| 4 | 63.37 | 60.97± | 45° BEND |
| 5 | 63.63 | 61.23± | CAP 1.0m FROM BUILDING |

PIPE CROSSING TABLE

| CROSSING | LOWER PIPE | HIGHER PIPE | CLEARANCE | SURFACE ELEVATION |
|----------|-------------------------|-----------------------------------|-----------|-------------------|
| 1 | 250mmØ SAN OBV=59.99 | 200mmØ STM INV=60.50 | 0.5m± | 63.14m |
| 2 | 200mmØ WM OBV=61.22 | 200mmØ STM INV=61.72 | 0.5m± | 63.62m |
| 3 | 200mmØ WM OBV=60.75 | HYDRO OTTAWA DUCT BANK INV=61.84± | 1.74m± | 63.16m |

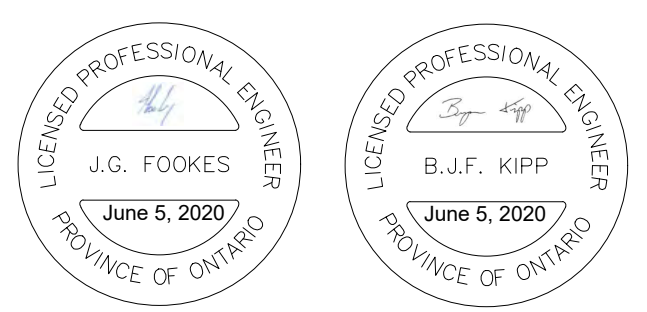
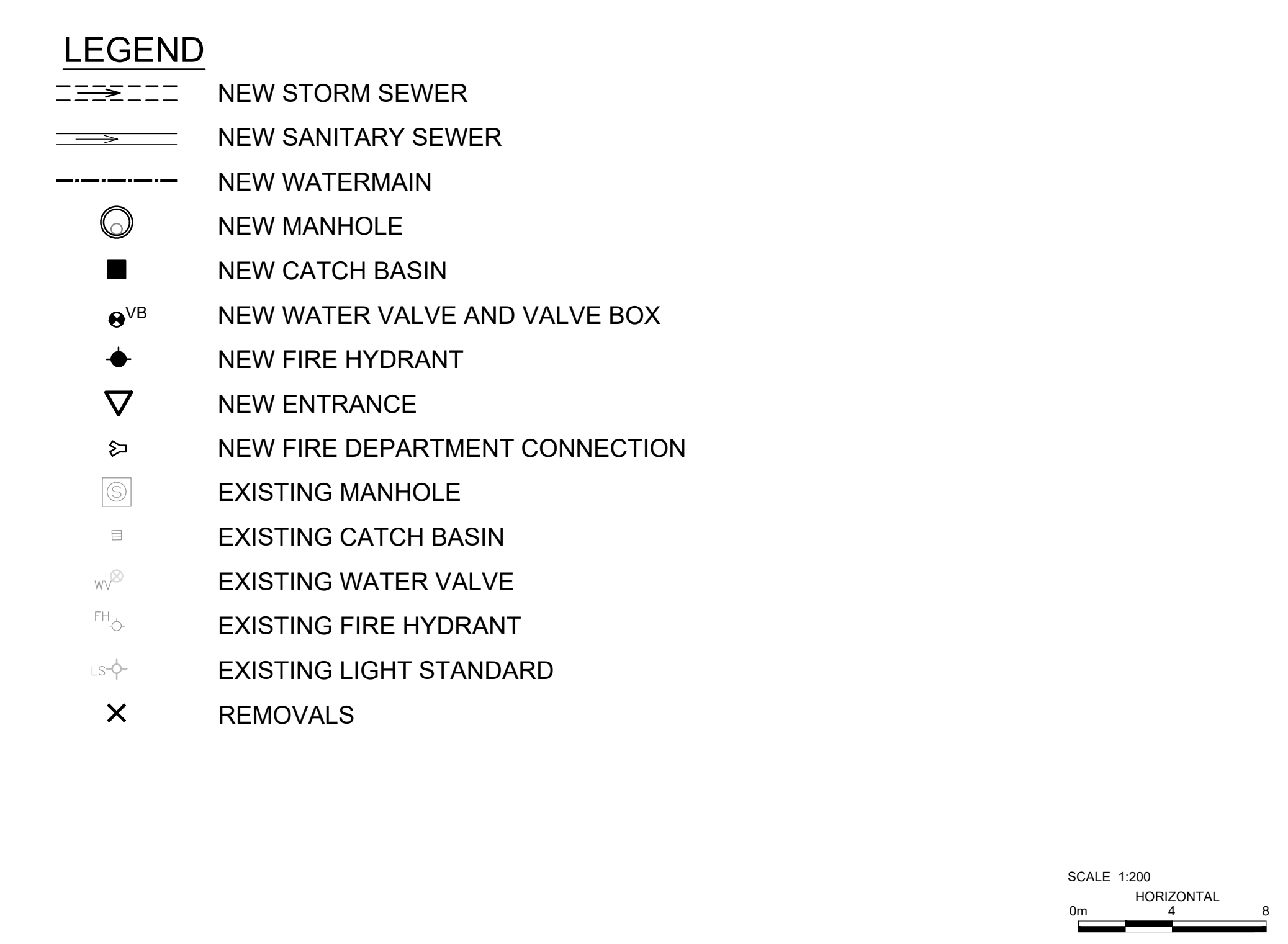
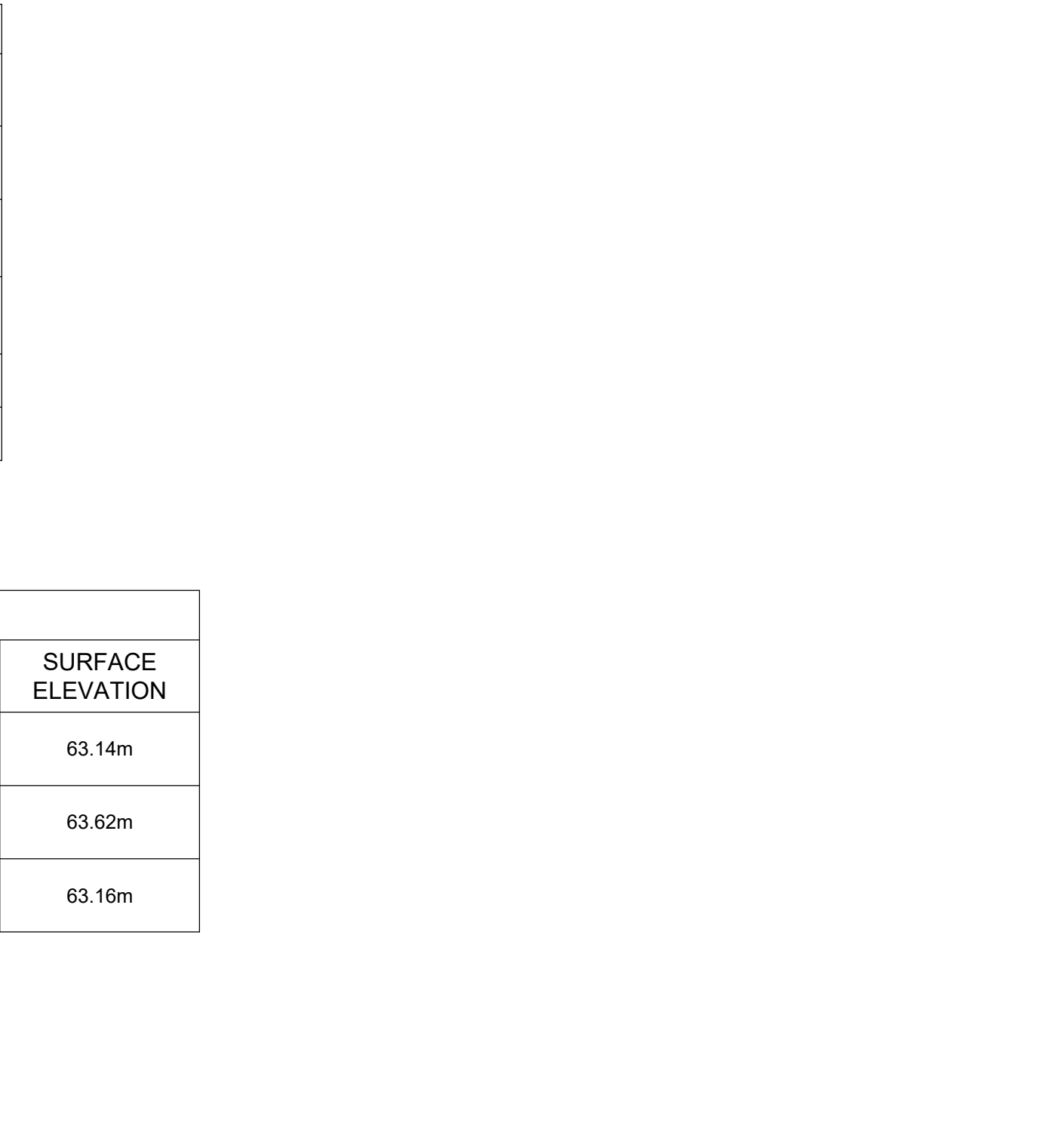

PRELIMINARY
NOT FOR CONSTRUCTION

KWC Architects Inc.
Architects in Joint Venture for the OPL-LAC Joint Facility
384 Adelaide Street West, Suite 100, Toronto, Canada M5H 1Y7
Tel: 416 862 8800 Fax: 416 862 2508 info@kwc.ca www.kwc.ca

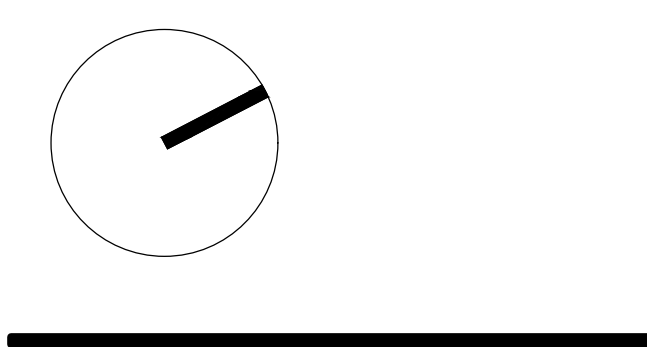

OPL - LAC JOINT FACILITY

555 ALBERT ST.
OTTAWA ON
K1R 7A3

SITE SERVICING PLAN

CONTRACTOR MUST CHECK & VERIFY ALL DIMENSIONS ON THE JOB.
 10% FINAL DRAWING
 ALL DRAWINGS, SPECIFICATIONS AND RELATED DOCUMENTS ARE THE COPYRIGHT PROPERTY OF THE ARCHITECT AND SHALL BE KEPT BY THE ARCHITECT. NO REPRODUCTION OF DRAWINGS, SPECIFICATIONS AND RELATED DOCUMENTS IN PART OR IN WHOLE IS FORBIDDEN WITHOUT THE WRITTEN PERMISSION OF THE ARCHITECT.
 THIS DRAWING IS NOT TO BE USED FOR CONSTRUCTION UNLESS ISSUED BY THE ARCHITECT.

MH MORRISON HERSHFELD
 200-2532 BASELINE ROAD, OTTAWA, ON K2H 1B1

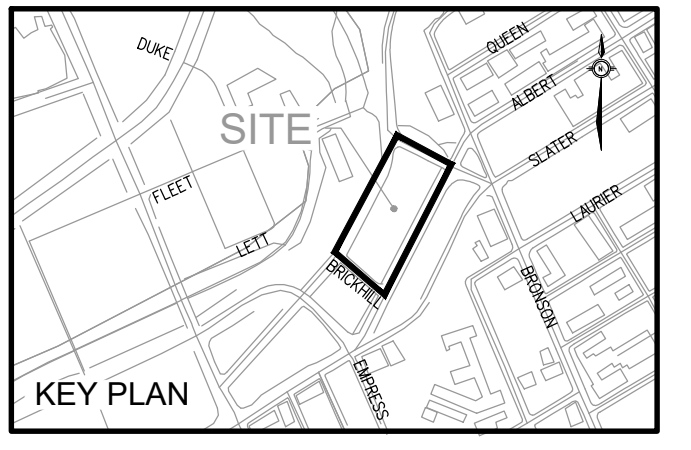

ISSUED
 No. Date Description
 0 05/06/20 ISSUED FOR SITE PLAN CONTROL

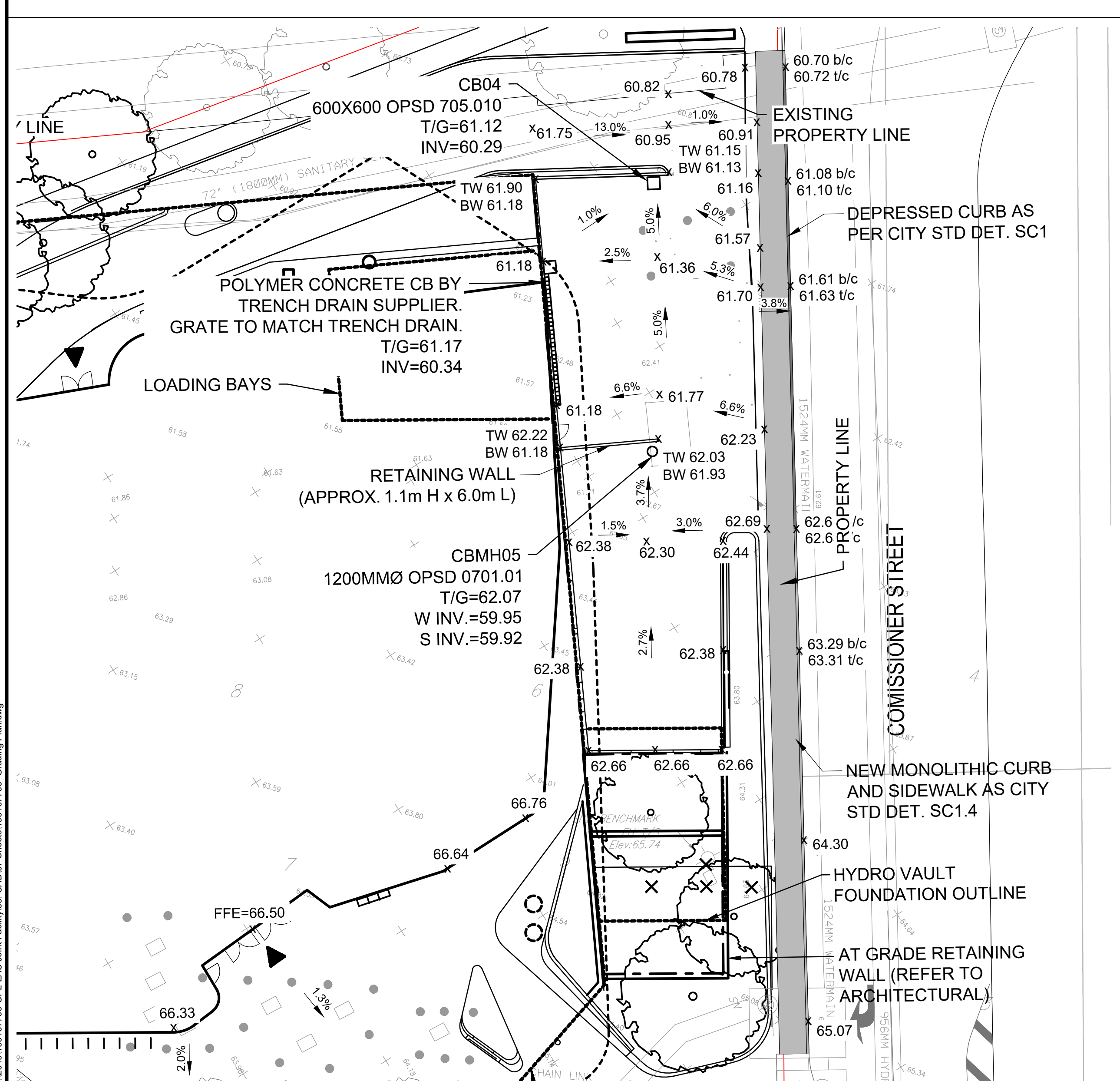
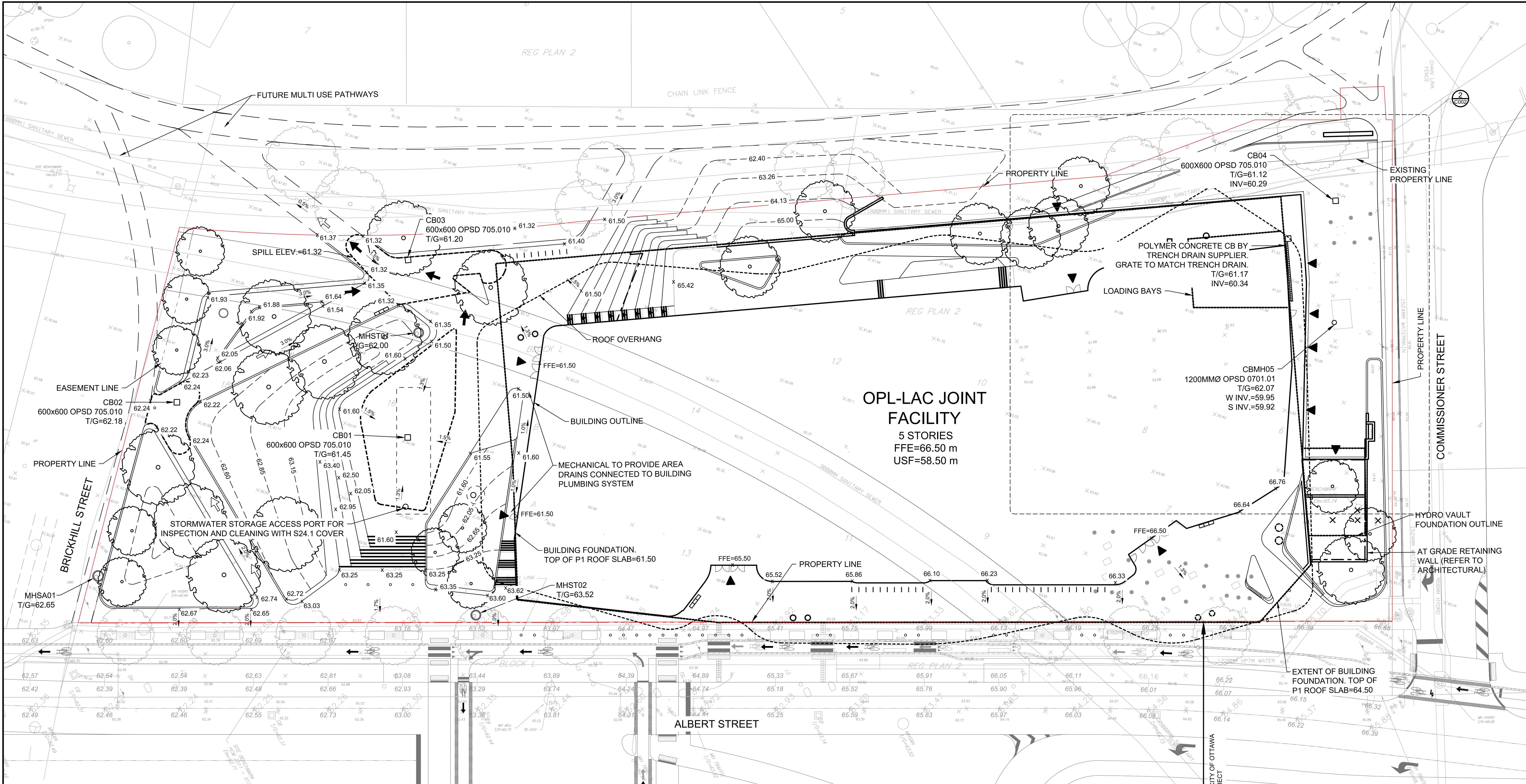

- NOTES:**
- ALL ELEVATIONS ARE GEODETIC.
 - REFER TO ARCHITECTURAL AND LANDSCAPE DRAWINGS FOR LAYOUT, DIMENSIONS AND SURFACE FINISHES.
 - THIS DRAWING SHALL BE READ IN CONJUNCTION WITH ALL OTHER DRAWINGS.
 - ALL ELEVATIONS BY CURBS ARE EDGE OF PAVEMENT UNLESS OTHERWISE INDICATED.
 - REFER TO GEOTECHNICAL INVESTIGATION REPORT (NO. 19131600 DATED FEBRUARY 20, 2020) PREPARED BY GOLDER ASSOCIATE FOR SUBSURFACE CONDITIONS, CONSTRUCTION RECOMMENDATIONS AND GEOTECHNICAL INSPECTION REQUIREMENTS. THE GEOTECHNICAL CONSULTANT SHALL REVIEW EXCAVATIONS PRIOR TO THE PLACEMENT OF GRANULAR MATERIAL.
 - REINSTATE ALL DISTURBED/DAMAGED AREAS TO THEIR ORIGINAL CONDITION OR BETTER.
 - PROVIDE POSITIVE DRAINAGE, MATCHING EXISTING OVERALL DRAINAGE PATTERN INDICATED.
 - ALL WORK AND MATERIALS SHALL BE IN ACCORDANCE WITH CITY OF OTTAWA AND/OR ONTARIO PROVINCIAL STANDARDS.
 - ALL TOPSOIL, ORGANIC OR DELETERIOUS MATERIAL MUST BE ENTIRELY REMOVED FROM BENEATH THE PROPOSED PAVED.
 - AREAS AS DIRECTED BY THE OWNER'S REPRESENTATIVE.
 - ALL AREAS SHALL DRAIN AT A MINIMUM OF 1% ANY DISCREPANCIES PREVENTING THIS SHALL BE REPORTED TO THE ENGINEER PRIOR TO CONTINUING WORK.
 - BLEND NEW EARTHWORK INTO EXISTING, PROVIDING VERTICAL CURVES OR ROUNDING AT ALL TOP AND BOTTOM OF SLOPES.
 - CONCRETE SIDEWALKS SHALL BE IN ACCORDANCE WITH CITY OF OTTAWA STANDARD DRAWING SC1.4 AND SC1.4.
 - CONCRETE BARRIER CURBS SHALL BE IN ACCORDANCE WITH CITY OF OTTAWA STANDARD DRAWING SC1.1.
 - ALL SIDEWALKS CONSTRUCTED IN CITY ROW, SHALL BE MONOLITHIC CONCRETE CURB AND SIDEWALK PER STD. DETAIL SC 2 UNLESS OTHERWISE INDICATED.
 - SAW CUT AND KEY GRIND ASPHALT AT ALL TIE-INS PER CITY OF OTTAWA STANDARD R10.
 - PROVIDE LINE PAINTING.
 - SNOW IS TO BE REMOVED FROM THE LOADING DOCK AND PARKING GARAGE RAMP. ON SITE SNOW STORAGE IS NOT PROPOSED FOR THESE AREAS.

- UTILITY NOTE**
- THE POSITION OF POLE LINES, CONDUITS, WATERMANS, SEWERS AND OTHER UNDERGROUND AND OVERGROUND UTILITIES AND STRUCTURES IS NOT NECESSARILY SHOWN ON THE CONTRACT DRAWINGS, AND, WHERE SHOWN, THE ACCURACY OF THE POSITION OF SUCH UTILITIES AND STRUCTURES IS NOT GUARANTEED. BEFORE STARTING WORK THE CONTRACTOR SHALL INQUIRE HIMSELF OF THE EXACT LOCATION OF ALL SUCH UTILITIES AND STRUCTURES, AND SHALL ASSUME ALL LIABILITY FOR DAMAGE TO THEM. THE CONTRACTOR WILL BE RESPONSIBLE FOR SUPPORTING AND PROTECTING ANY EXISTING UTILITIES, AS REQUIRED, IN ACCORDANCE WITH THE UTILITY OWNERS' REQUIREMENTS. THE CONTRACTOR IS REQUIRED TO OBTAIN LOCATES, IN ADVANCE OF EXCAVATION WORK, AND FORWARD COPIES OF THE LOCATES TO THE CONSULTANT AND THE OWNER PRIOR TO EXCAVATION. HAND EXCAVATION IS REQUIRED PER UTILITY OWNERS' REQUIREMENTS.

- LEGEND**
- NEW MANHOLE
 - NEW CATCH BASIN
 - PROPOSED ELEVATION
 - EXISTING ELEVATION
 - PROPOSED FINISH GRADE AT TOP OF WALL OR STEP
 - PROPOSED FINISH GRADE AT BOTTOM OF WALL OR STEP
 - PROPOSED TOP OF CURB ELEVATION
 - PROPOSED SLOPE DIRECTION
 - DIRECTION OF MAJOR OVERLAND FLOW
 - DIRECTION OF EMERGENCY OVERLAND FLOW
 - PROPOSED CURB
 - PROPOSED DEPRESSED CURB
 - EMERGENCY SPILL ELEVATION
 - NEW SIDEWALK

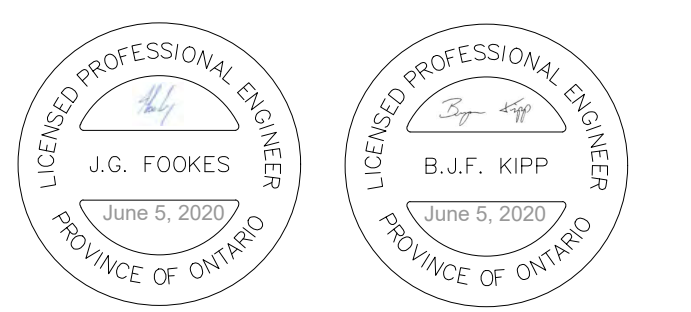

PRELIMINARY
 NOT FOR CONSTRUCTION

KWC Architects Inc.
 Architects in Joint Venture for the OPL-LAC Joint Facility
 384 Adelaide Street West, Suite 100, Toronto, Canada M5H 1Y7
 Tel: 416 882 8800 Fax: 416 882 2508 info@kwc.ca www.kwc.ca

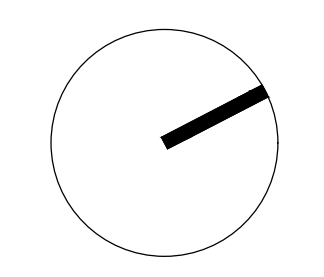

OPL - LAC JOINT FACILITY

555 ALBERT ST.
 OTTAWA ON
 K1R 7X3

GRADING PLAN

Scale: 1:200
 Project No: 19H187
 Date: 05/06/20

C002

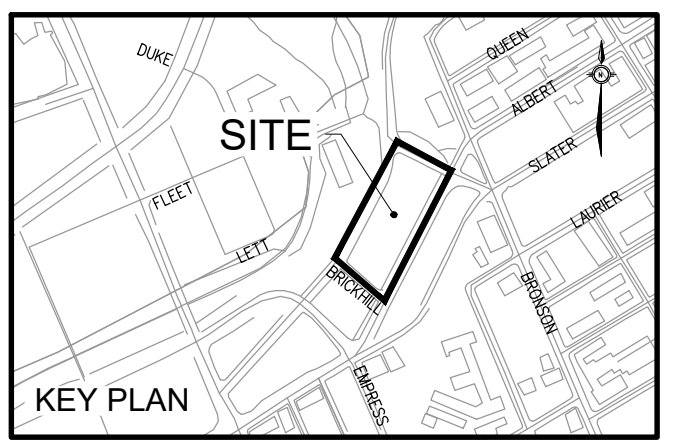

| No. | Date | Description |
|-----|----------|------------------------------|
| 0 | 05/06/20 | ISSUED FOR SITE PLAN CONTROL |

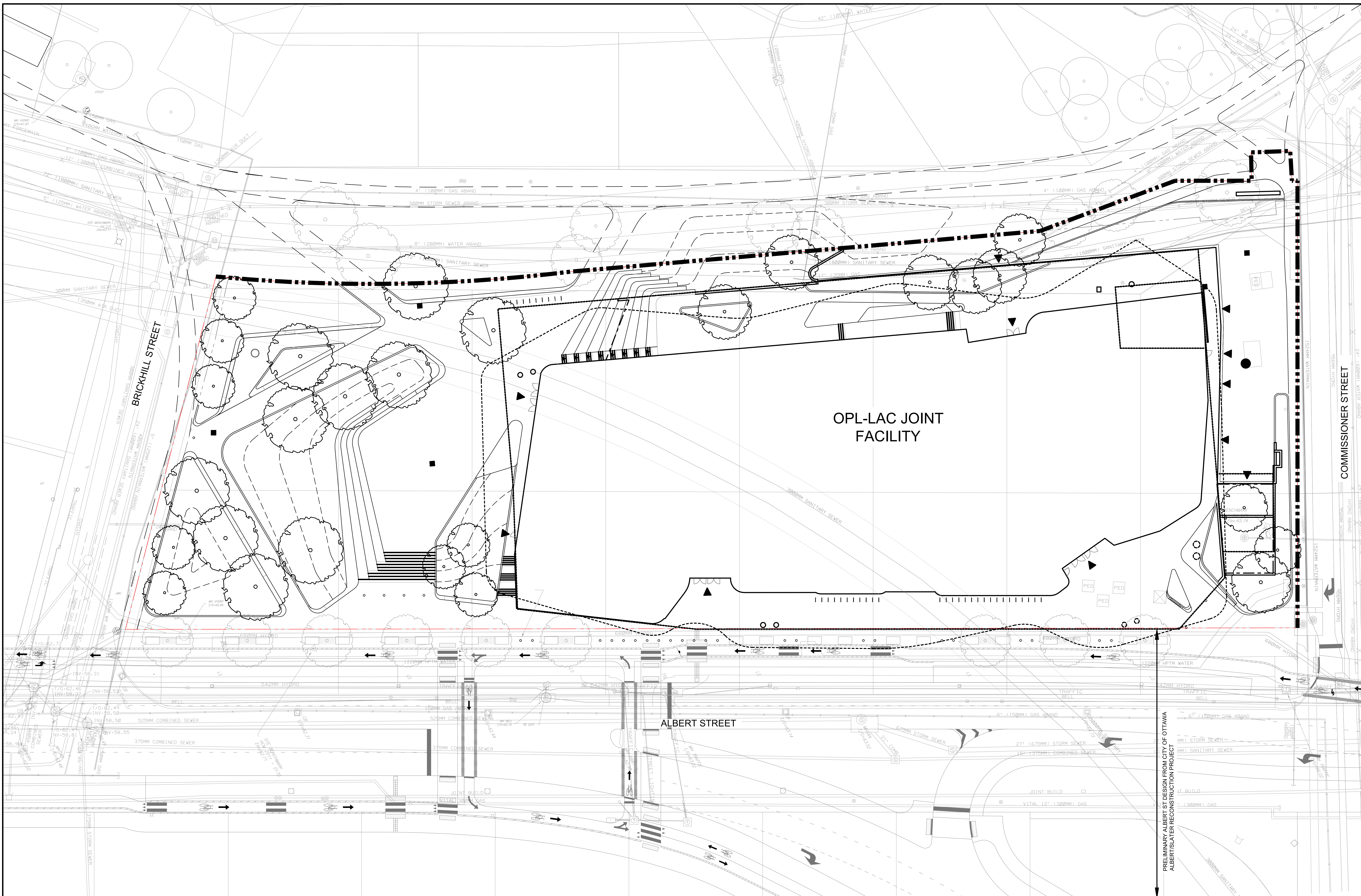

EROSION AND SEDIMENT CONTROL NOTES:

1. THE CONTRACTOR SHALL IMPLEMENT BEST MANAGEMENT PRACTICES, TO PROVIDE FOR PROTECTION OF THE AREA DRAINAGE SYSTEM AND THE RECEIVING WATERCOURSE, DURING CONSTRUCTION ACTIVITIES. THIS INCLUDES LIMITING THE AMOUNT OF EXPOSED SOIL, USING FILTER CLOTH UNDER THE GRATES OF CATCHBASINS AND MANHOLES, AND INSTALLING SILT FENCES AND OTHER EFFECTIVE SEDIMENT TRAPS. THE CONTRACTOR ACKNOWLEDGES THAT FAILURE TO IMPLEMENT APPROPRIATE EROSION AND SEDIMENT CONTROL MEASURES MAY BE SUBJECT TO PENALTIES IMPOSED BY ANY APPLICABLE REGULATORY AGENCY TO BE PAID FOR AT THE CONTRACTOR'S EXPENSE.
2. EROSION AND SEDIMENT CONTROL MEASURES ARE TO BE IMPLEMENTED PRIOR TO CONSTRUCTION AND REMAIN IN PLACE UNTIL VEGETATION IS ESTABLISHED AND APPROVAL IS GRANTED BY THE ENGINEER TO REMOVE MEASURES.
3. REGULAR INSPECTION AND MAINTENANCE OF THE EROSION AND SEDIMENT MEASURES SHALL BE UNDERTAKEN. THE IMPLEMENTATION AND ADJUSTMENT AND/OR CORRECTIVE MAINTENANCE OF THE EROSION AND SEDIMENT MEASURES IS AN INTEGRAL PART OF THE PLAN AND MUST BE PERFORMED.
4. CATCH BASIN SEDIMENT PROTECTION SHALL BE PROVIDED FOR ALL CATCH BASINS, CATCH BASIN MAINTENANCE HOLES, DITCH INLETS AND OPEN GRATE MAINTENANCE HOLES WITHIN THE WORK AREA, WITHIN 50m OF THE WORK AREA, OR WHICH RECEIVE RUN-OFF FROM THE WORK AREA. CATCH BASIN INLET PROTECTION IS REQUIRED BOTH FOR EXISTING STRUCTURES (INCLUDING STRUCTURES WHICH WILL BE REMOVED AS PART OF THE WORK) AND NEW STRUCTURES INSTALLED AS PART OF THE WORK. CATCH BASIN SEDIMENT PROTECTION SHALL INVOLVE BOTH (i) WRAPPING GRATE WITH FILTER CLOTH, AND (ii) SURROUNDING CATCH BASIN WITH SEDIMENT CAPTURE FILTER SOCK. SEDIMENT CAPTURE FILTER SOCK SHALL BE STACKED (ON SOFT GROUND) OR HELD IN PLACE USING SANDBAGS (ON PAVED AREAS). CATCH BASIN SEDIMENT PROTECTION SHALL BE INSPECTED REGULARLY AND MAINTAINED AS NECESSARY. ANY VISIBLE ACCUMULATION OF SEDIMENT SHALL BE REMOVED AND DISPOSED OFF-SITE.
5. ALL SEDIMENT CONTROL MEASURES SHALL BE INSPECTED ON A REGULAR BASIS AND FOLLOWING STORM EVENTS FOR INTEGRITY AND FUNCTION BY THE CONTRACTOR. ANY REQUIRED REPAIRS TO EROSION AND SEDIMENT CONTROL MEASURES TO BE COMPLETED WITHIN 24 HOURS.
6. ALL SEDIMENT CONTROL MEASURES ARE TO BE MAINTAINED BY THE CONTRACTOR AS NECESSARY. SEDIMENTS REMOVED FROM THE CONTROL MEASURES (SILT FENCES, CATCH BASIN SEDIMENT CONTROLS, ETC.) SHALL BE DISPOSED OF IN ACCORDANCE WITH MOECC GUIDELINES.
7. IF NECESSARY, ADDITIONAL SEDIMENT CONTROL MEASURES MAY BE INSTALLED AS DIRECTED BY THE ENGINEER OR THE RIDEAU VALLEY CONSERVATION AUTHORITY.

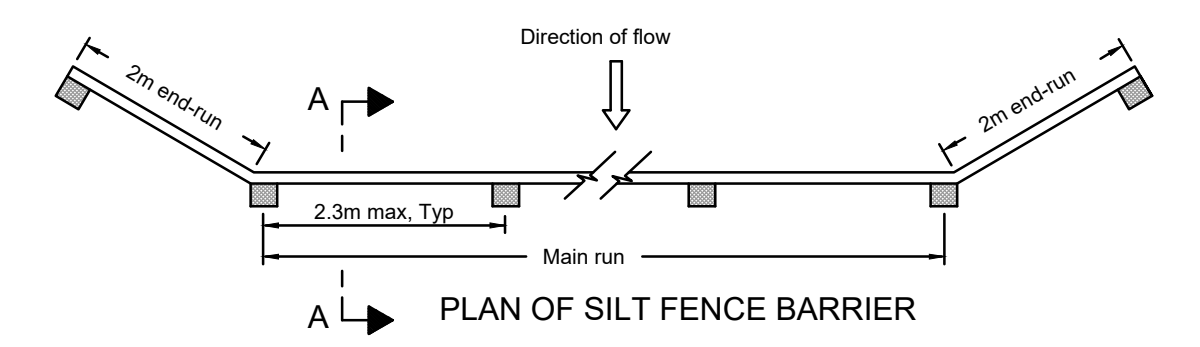
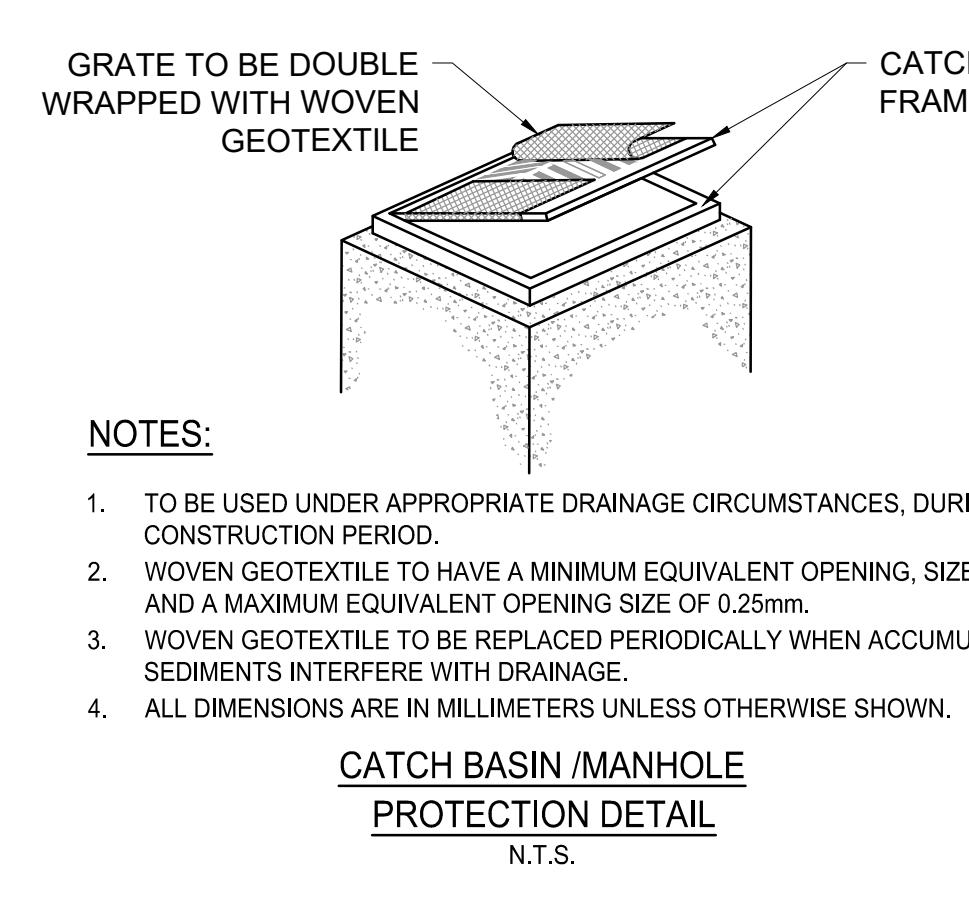
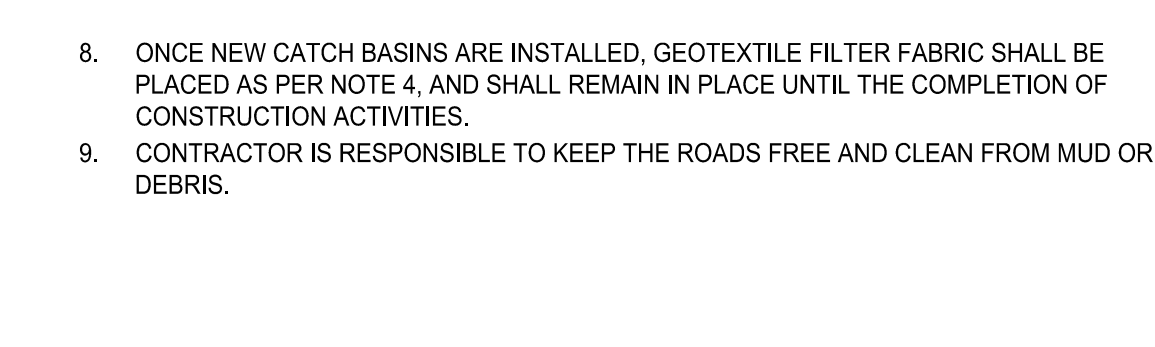

NOTES:
1. WOVEN GEOTEXTILE TO HAVE A MINIMUM EQUIVALENT OPENING SIZE OF 0.15mm AND A MAXIMUM EQUIVALENT OPENING SIZE OF 0.25mm.
2. WOVEN GEOTEXTILE TO HAVE A HORIZONTAL OVERLAP OF 100mm AT JOINTS.
3. ALL DIMENSIONS ARE IN MILLIMETERS UNLESS OTHERWISE SHOWN.

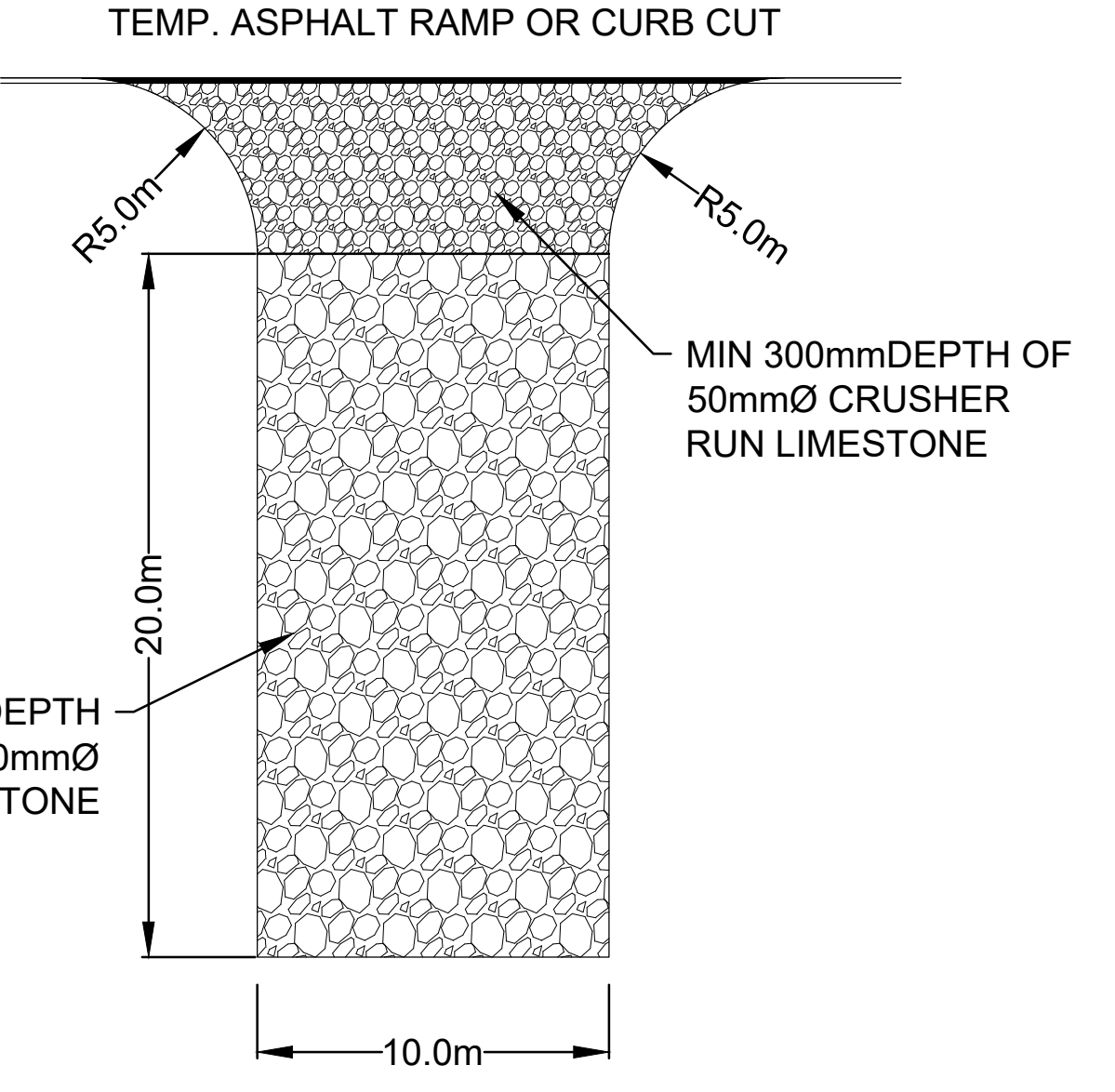
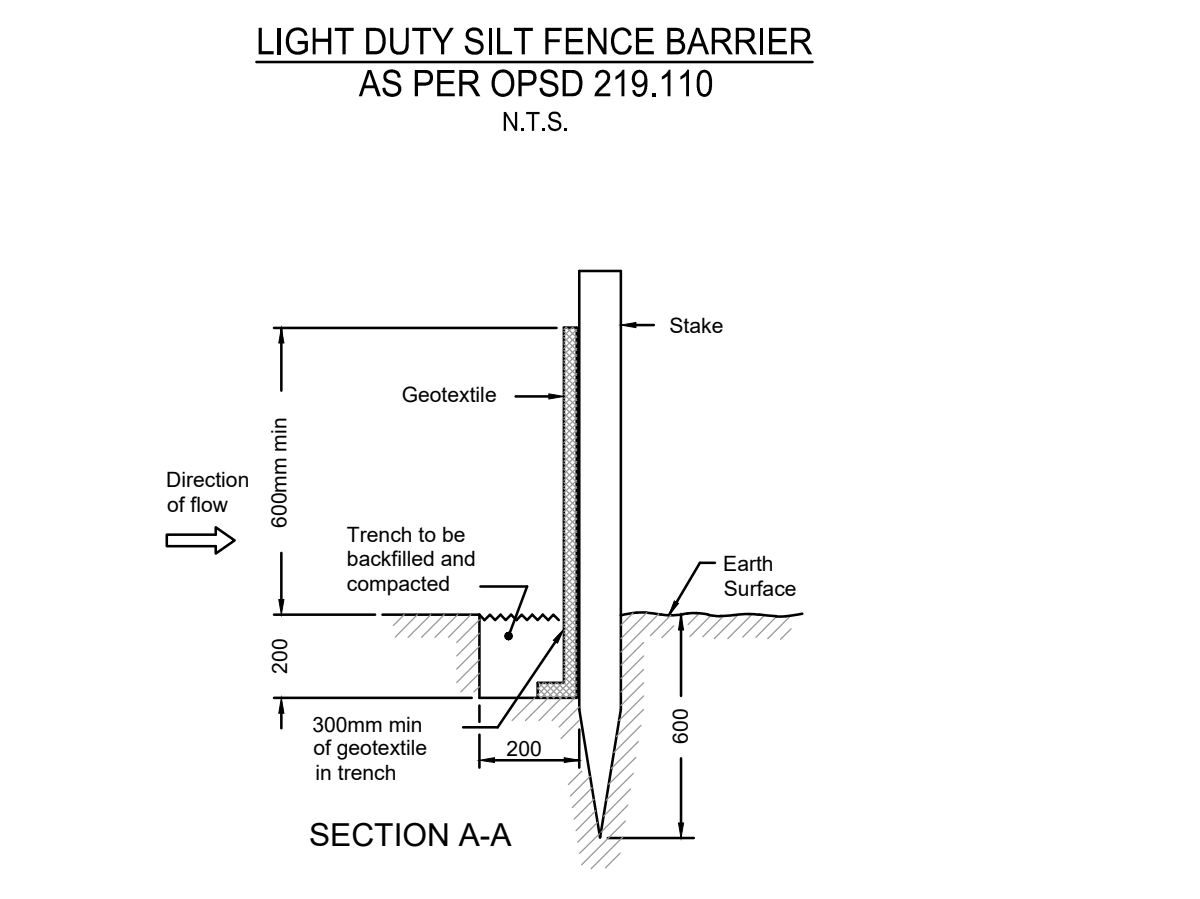

NOTES:
1. INSTALL AT ALL SITE ACCESS LOCATIONS.
2. TEMPORARY CONSTRUCTION ACCESS SHALL BE REMOVED ON COMPLETION OF THE WORK AND ALL DISTURBED AREAS SHALL BE RESTORED TO ORIGINAL OR BETTER CONDITION.

- LEGEND**
- NEW CATCH BASINS SEDIMENT PROTECTION (SEE NOTE 8)
 - - - LIGHT DUTY SILT FENCE BARRIER (PER OPSD 219.110)

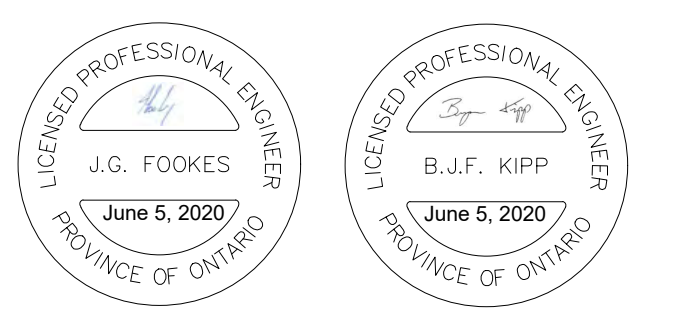

PRELIMINARY NOT FOR CONSTRUCTION

KWC Architects Inc.
Architects in Joint Venture for the OPL-LAC Joint Facility
384 Adelaide Street West, Suite 100, Toronto, Canada M5H 1Y7
Tel: 416 862 8800 Fax: 416 862 5208 info@kwa.ca www.kwa.ca

OPL - LAC JOINT FACILITY

555 ALBERT ST.
OTTAWA ON
K1R 7X3

EROSION AND SEDIMENT CONTROL PLAN

Scale: 1:200
Project No: 1901877
Date: 05/06/20

C003

CONTRACTOR MUST CHECK & VERIFY ALL DIMENSIONS ON THE JOB.
 30 METRIC DRAWING
 ALL DRAWINGS, SPECIFICATIONS AND RELATED DOCUMENTS ARE THE COPYRIGHT PROPERTY OF THE ARCHITECT AND SHALL BE RETURNED TO THE ARCHITECT UPON COMPLETION OF THE PROJECT.
 SPECIFICATIONS AND RELATED DOCUMENTS IN PART OR IN WHOLE IS FORBIDDEN WITHOUT THE WRITTEN PERMISSION OF THE ARCHITECT.
 THIS DRAWING IS NOT TO BE USED FOR CONSTRUCTION UNLESS ISSUED BY THE ARCHITECT.

MORRISON HERSHFELD
 200-2532 BASELINE ROAD, OTTAWA, ON K2H 1B1

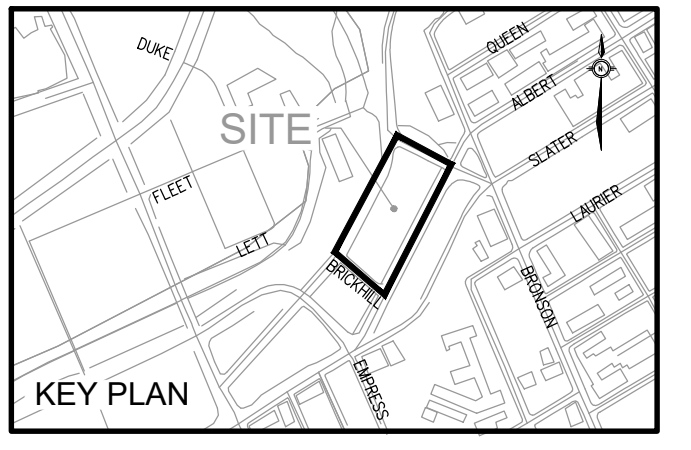

ISSUED
 0 05/06/20 ISSUED FOR SITE PLAN CONTROL

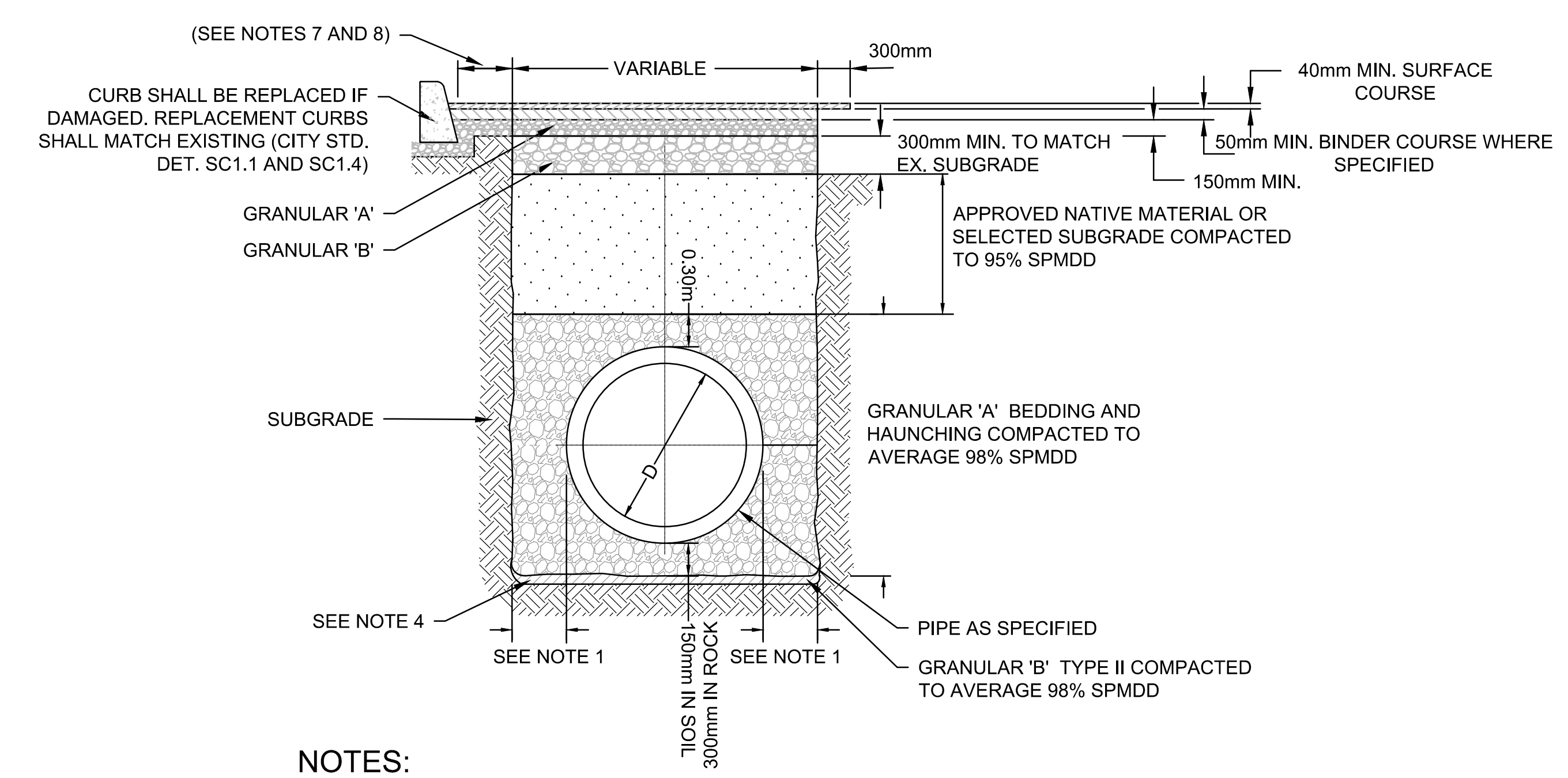

NOTES:

- | PIPE INSIDE DIAMETER (mm) | CLEARANCE (mm) |
|---------------------------|----------------|
| 900 | CONC 450 |
| OR LESS | PVC 450 |
| OVER 900 | 500 |
- FINAL BACKFILL - APPROVED NATIVE MATERIAL OR SELECT SUBGRADE
 - ALL DIMENSION ARE IN MILLIMETERS UNLESS SHOWN OTHERWISE.
 - WHEN NECESSARY POOR SOILS SHALL BE EXCAVATED TO CREATE A FOUNDATION THAT SHALL BE FILLED TO THE BOTTOM OF THE BEDDING WITH GRANULAR 'B'.
 - THE USE OF CLEAR CRUSHED STONE AS A BEDDING LAYER IS NOT PERMITTED ANYWHERE ON THIS SITE.
 - ALL EXISTING ASPHALT AND CONCRETE REMOVAL LIMITS TO BE SAWCUT.
 - 300 MM KEY TO BE SAWCUT AND REMOVED OR MILLED.
 - ROAD REINSTATEMENT ON THE CURB SIDE OF THE TRENCH EXCAVATION SHALL EXTEND TO THE CURB FACE.
 - TACK COAT SHALL BE APPLIED TO ALL MILLED SURFACES
 - ALL EXISTING ASPHALT REMOVAL AND CONCRETE LIMITS TO BE SAWCUT

1 SEWER INSTALLATION
 TYPICAL DETAIL
 N.T.S.

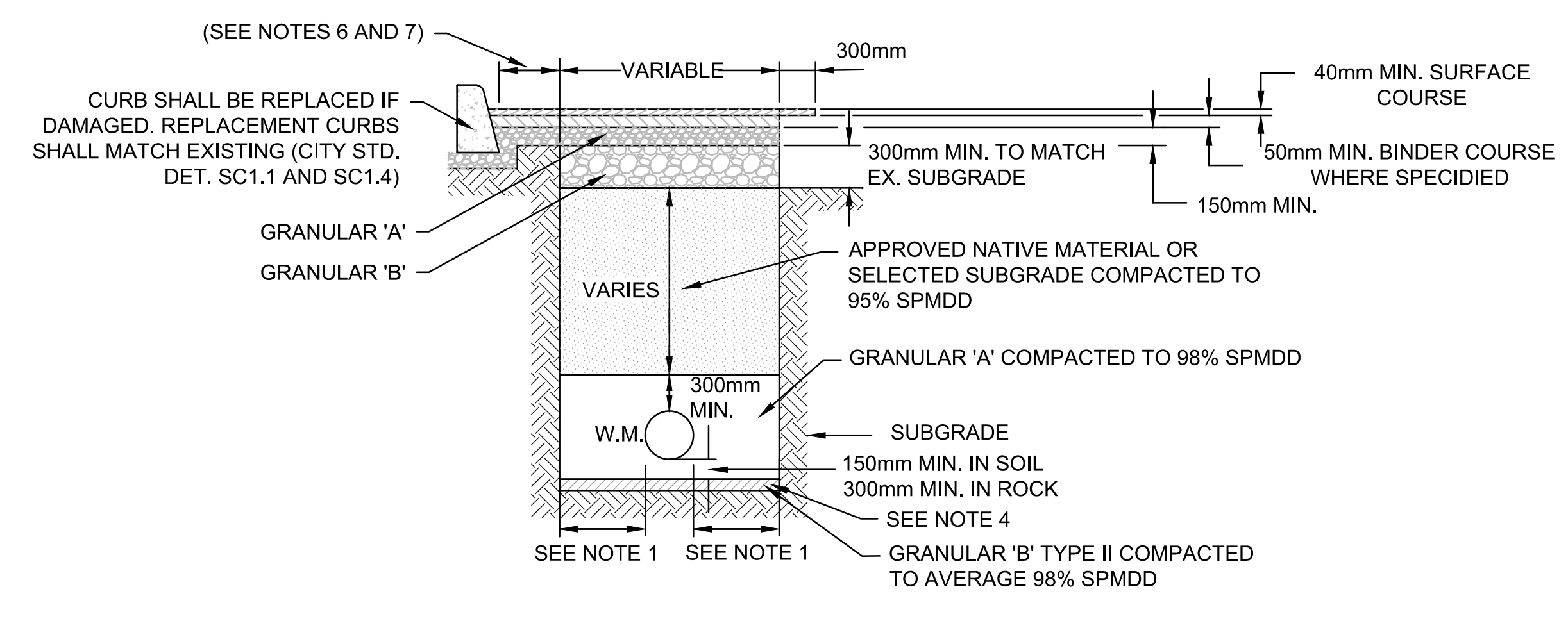

NOTES:

- | PIPE INSIDE DIAMETER (mm) | CLEARANCE (mm) |
|---------------------------|----------------|
| 900 | 450 |
| OR LESS | 450 |
| OVER 900 | 500 |
- ALL EXISTING ASPHALT REMOVAL AND CONCRETE LIMITS TO BE SAWCUT.
 - TRENCH SHALL BE IN ACCORDANCE WITH CITY OF OTTAWA STANDARD DETAIL W17.
 - WHEN NECESSARY POOR SOILS SHALL BE EXCAVATED TO CREATE A FOUNDATION THAT SHALL BE FILLED TO THE BOTTOM OF THE BEDDING WITH GRANULAR 'B'.
 - THE USE OF CLEAR CRUSHED STONE AS A BEDDING LAYER IS NOT PERMITTED ANYWHERE ON THIS SITE.
 - 300mm KEY TO BE SAWCUT AND REMOVED OR MILLED.
 - ROAD REINSTATEMENT ON THE CURB SIDE OF THE TRENCH EXCAVATION SHALL EXTEND TO THE CURB FACE.
 - TACK COAT SHALL BE APPLIED TO ALL MILLED SURFACES.

2 WATERMAIN INSTALLATION
 TYPICAL DETAIL
 N.T.S.

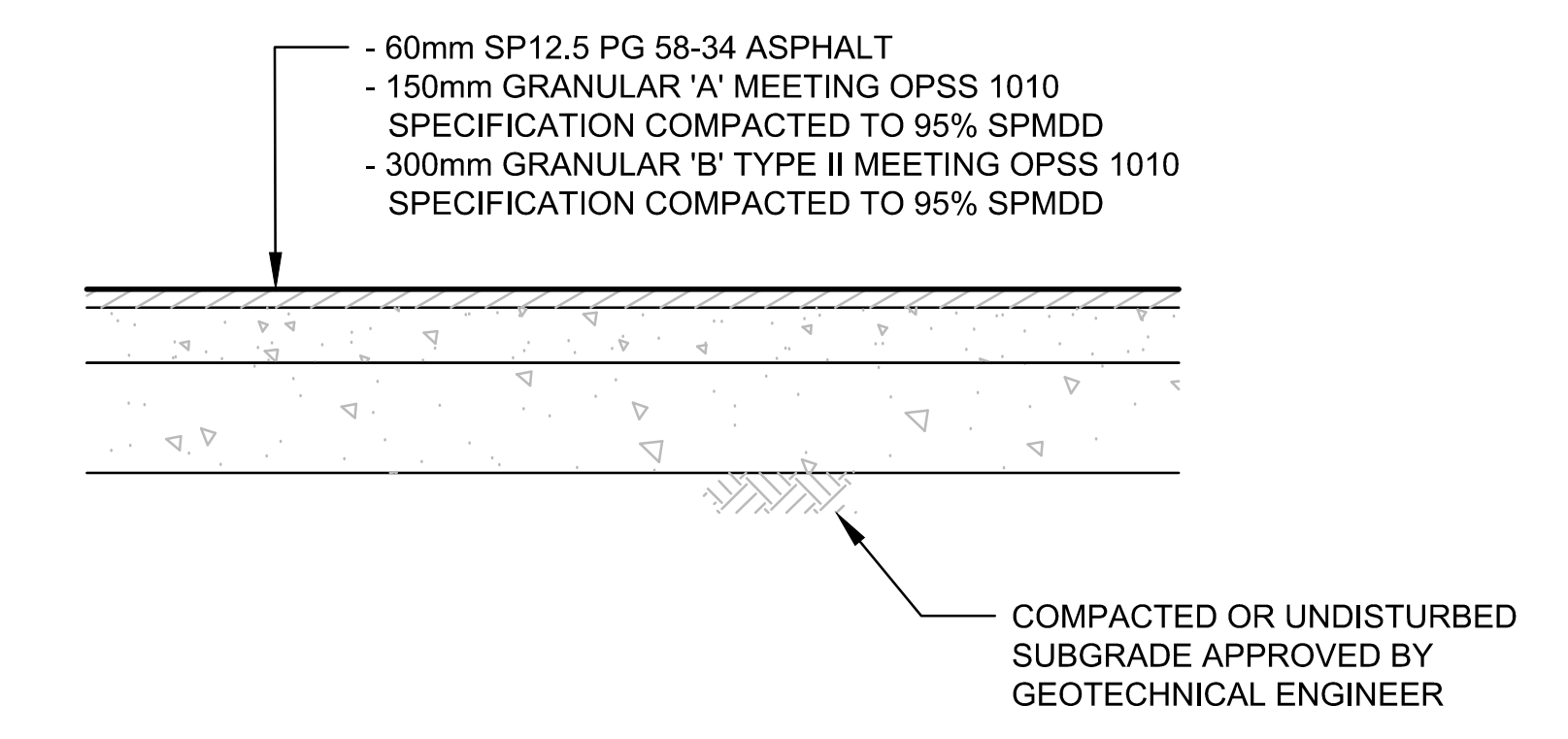

LIGHT DUTY PAVEMENT
 N.T.S.

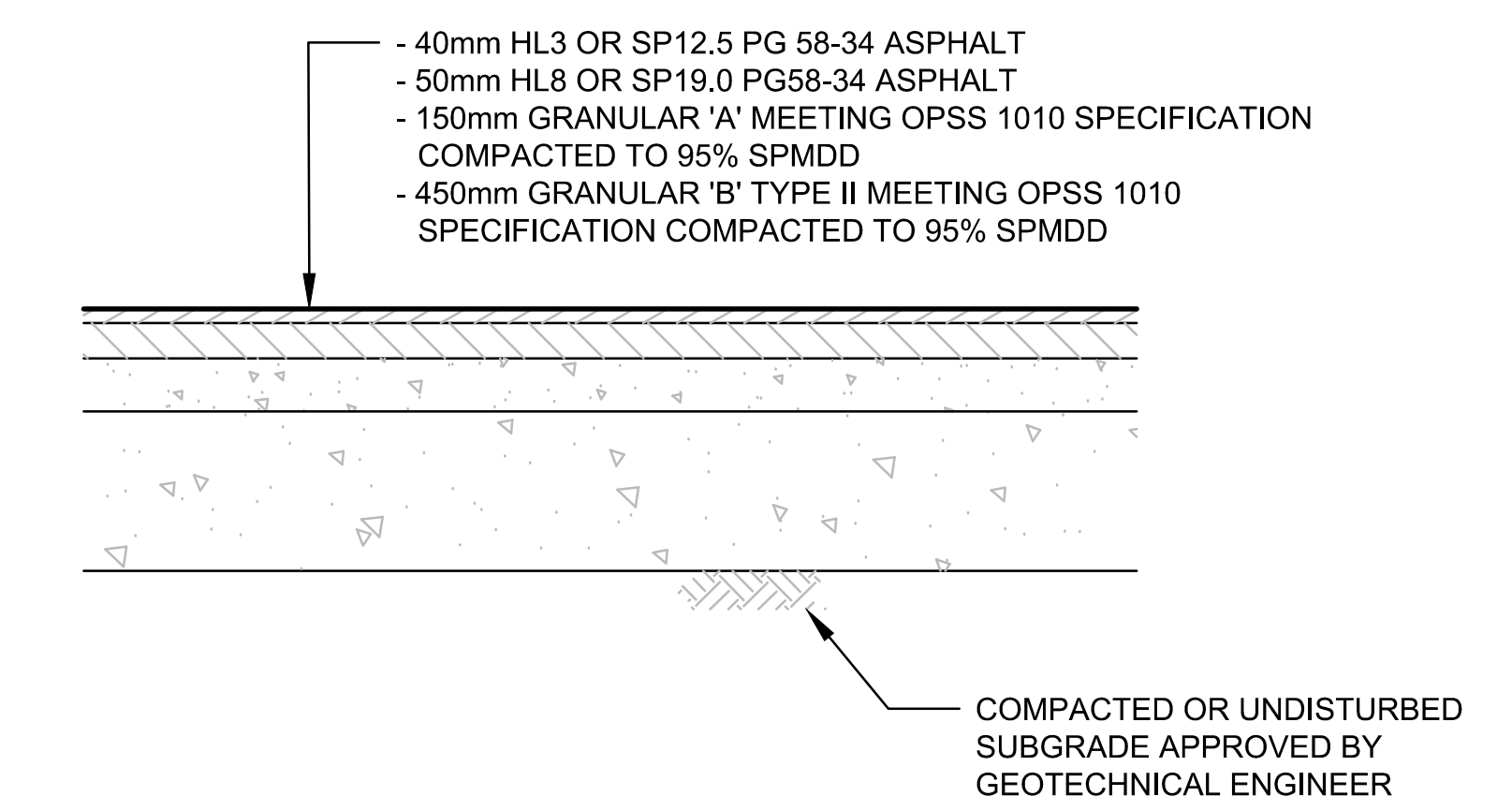

HEAVY DUTY PAVEMENT
 N.T.S.

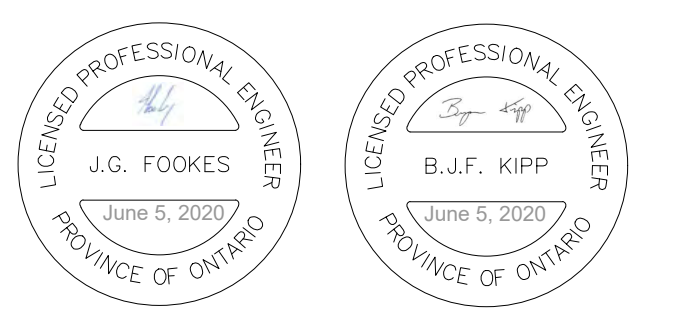

PRELIMINARY
 NOT FOR CONSTRUCTION

KWC Architects Inc.
 Architects in Joint Venture for the OPL/LAC Joint Facility
 384 Adelaide Street West, Suite 100, Toronto, Canada M5H 1Y7
 Tel: 416 862 8800 Fax: 416 862 5508 info@kwa.ca www.kwa.ca

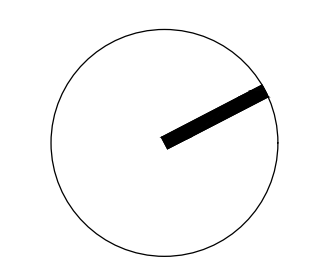

OPL - LAC JOINT FACILITY

555 ALBERT ST.
 OTTAWA ON
 K1R 7X3

DETAILS

Scale: 1:200
 Project No: 1901817
 Date: 05/06/20

C004

C:\Users\jfookes\OneDrive\Documents\OPL_LAC Joint Facility\DWG\DWG\05-06-20\05-06-20-004.dwg
 2020/06/05 10:00:00 AM
 J.G. Fookes

CONTRACTOR MUST CHECK & VERIFY ALL DIMENSIONS ON THE JOB.
 ALL DIMENSIONS ARE TO FACE UNLESS OTHERWISE NOTED.
 ALL DIMENSIONS ARE TO FACE UNLESS OTHERWISE NOTED.
 ALL DIMENSIONS ARE TO FACE UNLESS OTHERWISE NOTED.
 ALL DIMENSIONS ARE TO FACE UNLESS OTHERWISE NOTED.

MORRISON HERSHFELD
 200-2532 BASELINE ROAD, OTTAWA, ON K2H 1B1

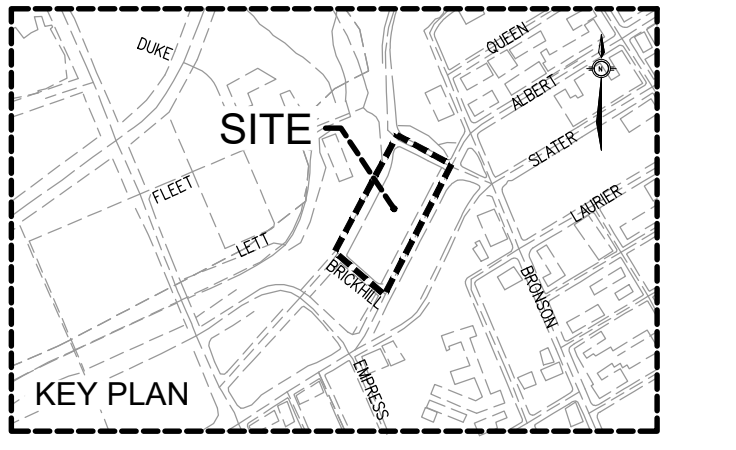

ISSUED

| No. | Date | Description |
|-----|----------|------------------------------|
| 0 | 05/06/20 | ISSUED FOR SITE PLAN CONTROL |

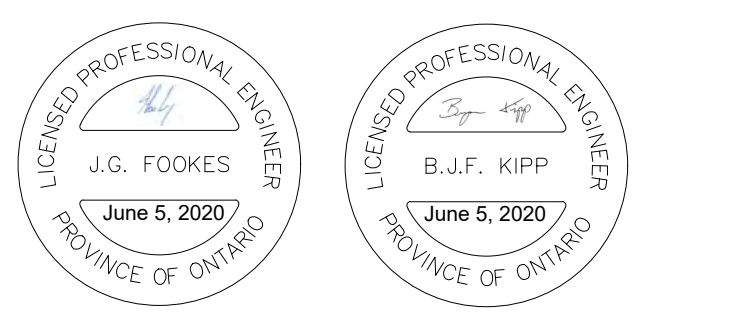
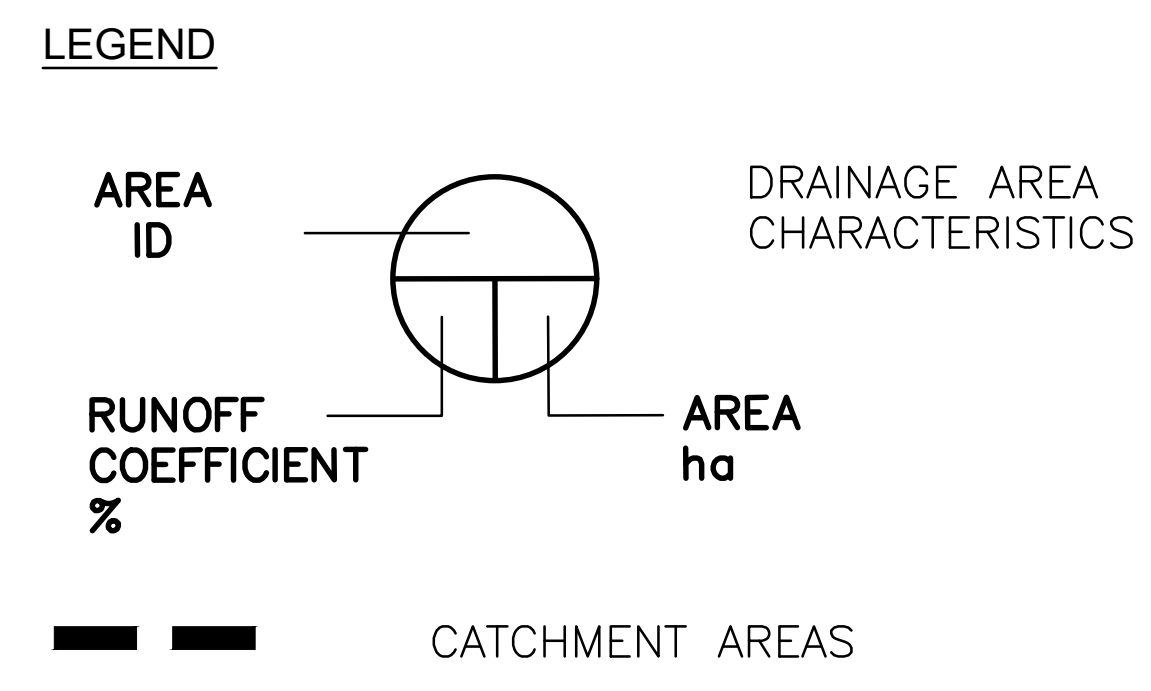
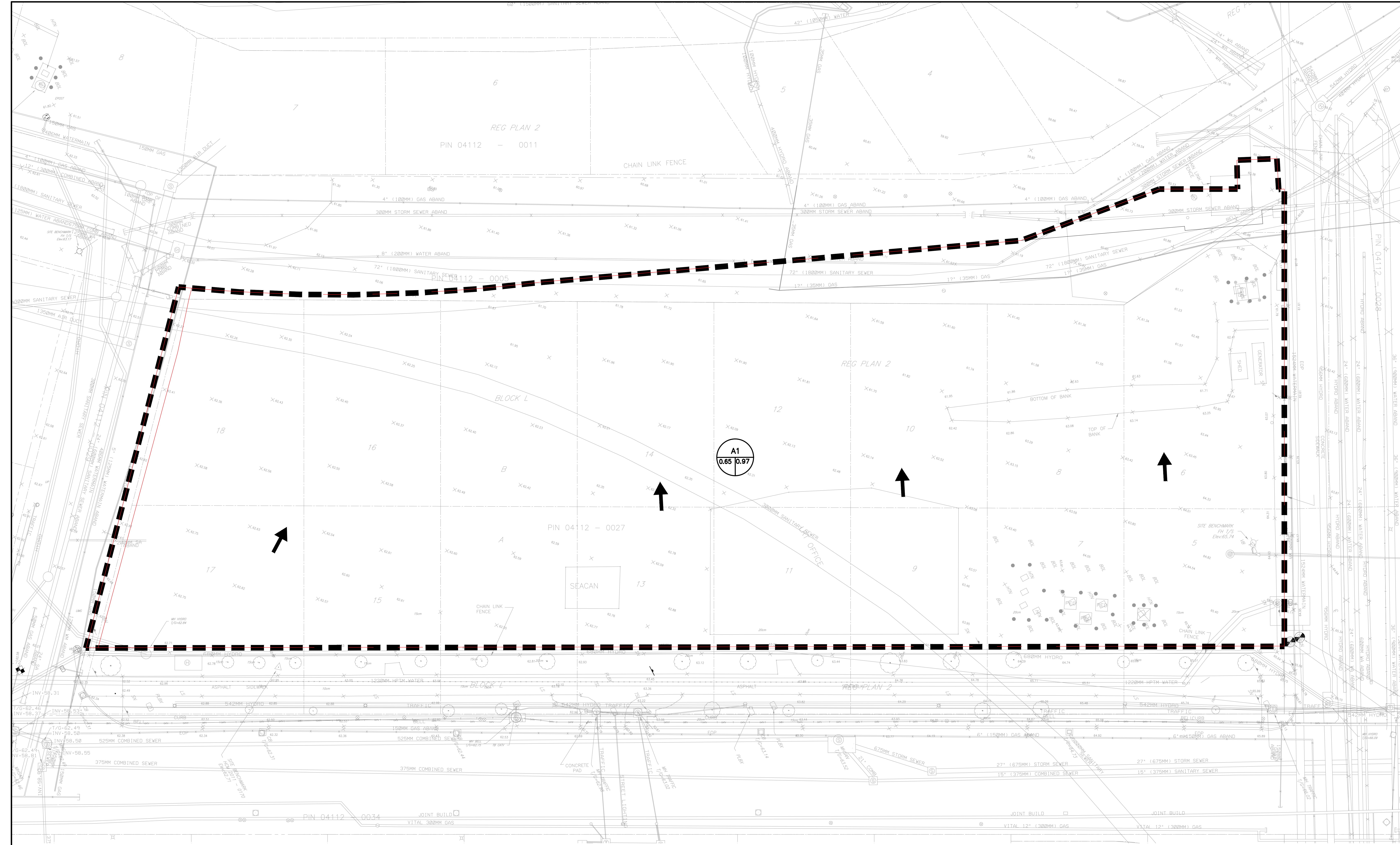

PRELIMINARY
 NOT FOR CONSTRUCTION

KWC Architects Inc.
 Architects in Joint Venture for the OPL/LAC Joint Facility
 384 Adelaide Street West, Suite 100, Toronto, Canada M5H 1Y7
 Tel: 416 862 8800 Fax: 416 862 5208 info@kwc.ca www.kwc.ca

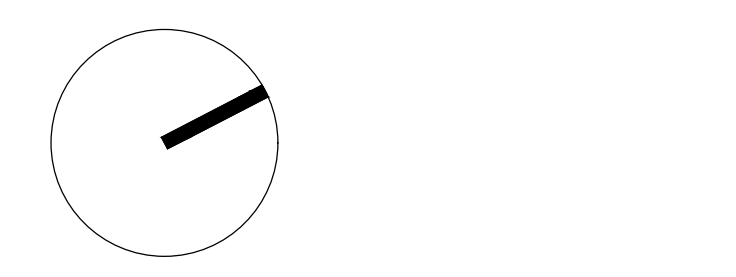

OPL - LAC JOINT FACILITY

555 ALBERT ST.
 OTTAWA ON
 K1R 7X3

EXISTING CATCHMENTS

Scale: 1:200
 Project No: 190187
 Date: 05/06/20
 C900

C:\Users\jfookes\OneDrive - Morrison Hershfeld\Documents\OPL LAC Joint Facility\DWG\OPL LAC Joint Facility\DWG\Site Plan\Site Plan.dwg
 2020/05/06 10:00:00 AM
 J.C. FOKES
 1:200
 05/06/20



CONTRACTOR MUST CHECK & VERIFY ALL DIMENSIONS ON THE JOB.
 ALL DIMENSIONS, SPECIFICATIONS AND RELATED DOCUMENTS ARE THE COPYRIGHT PROPERTY OF THE ARCHITECT AND MUST BE PROTECTED FROM UNAUTHORIZED REPRODUCTION OR DISSEMINATION. SPECIFICATIONS AND RELATED DOCUMENTS ARE PART OF A PACKAGE OF DOCUMENTS WITHOUT WHICH THE WORK IS INCOMPLETE.
 THIS DRAWING IS NOT TO BE USED FOR CONSTRUCTION UNLESS ISSUED BY THE ARCHITECT.

MORRISON HERSHFIELD
 200-2532 BASELINE ROAD, OTTAWA, ON K2H 1B1

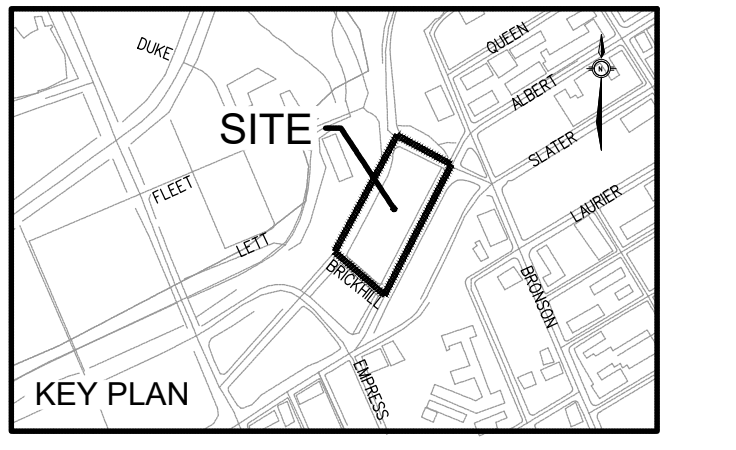

ISSUED

| No. | Date | Description |
|-----|----------|------------------------------|
| 0 | 05/06/20 | ISSUED FOR SITE PLAN CONTROL |

LEGEND

| | | |
|-----------------------------|--|--------------------------------------|
| AREA ID | | DRAINAGE AREA CHARACTERISTICS |
| RUNOFF COEFFICIENT % | | AREA ha |
| | | CATCHMENT AREAS |

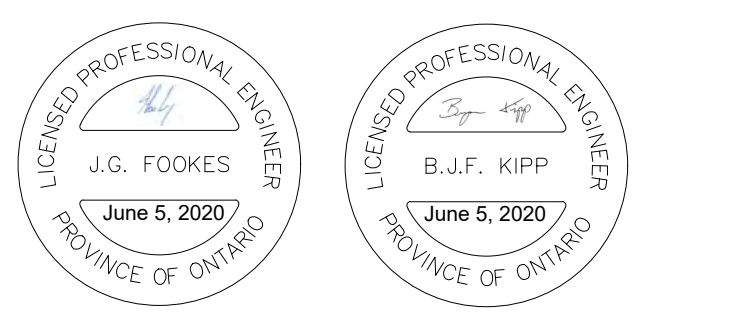

PRELIMINARY
 NOT FOR CONSTRUCTION

KWC Architects Inc.
 Architects in Joint Venture for the OPL/LAC Joint Facility
 384 Adelaide Street West, Suite 100, Toronto, Canada M5H 1Y7
 Tel: 416 862 8800 Fax: 416 862 2508 info@kwa.com www.kwa.com

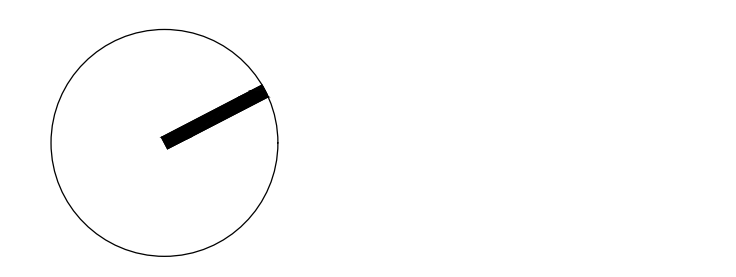

OPL - LAC JOINT FACILITY

555 ALBERT ST.
 OTTAWA ON
 K1R 7X3

PROPOSED CATCHMENTS

Scale: 1:200
 Project No: 1901877
 Date: 05/06/20

C901

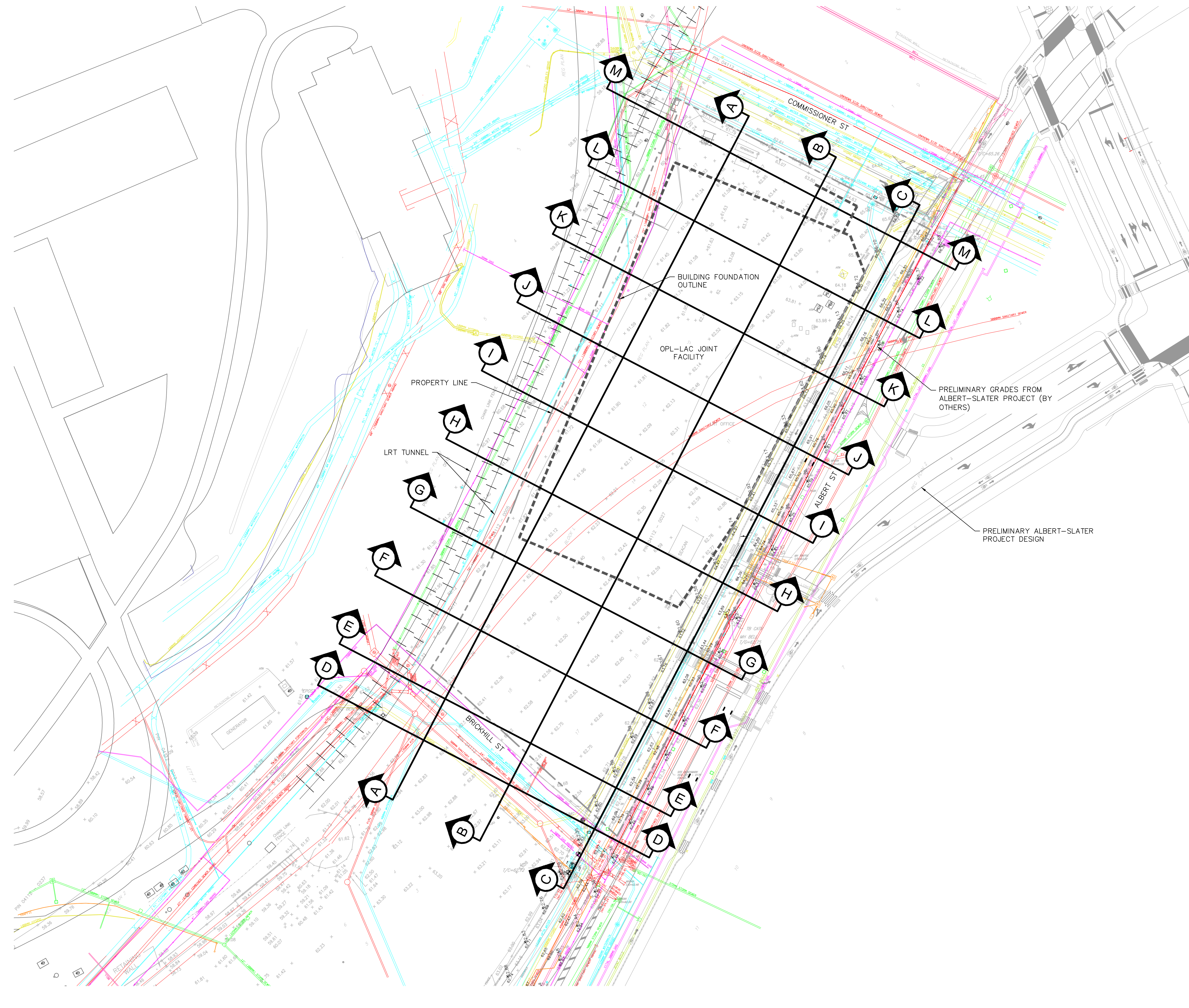

OPL - LAC JOINT FACILITY
PROJECT: 1901677



EXISTING UTILITIES - PLAN

Contract No. 190167700 Drawing No. C800
Sheet No. 1 of 3
Asset No.

Alain C. Gonthier, P. Eng. Director, Infrastructure Services
Paul Hussar Project Manager

Asset Group ISD

Des: NC Chk'd: BK
Dwn: NI Chk'd: JF

Utility Circulation No.:

Construction Inspector:
Scale: 1:300
0m 5 10

NOTE:
The location of utilities is approximate only, the exact location should be determined by consulting the municipal authorities and utility companies concerned. The contractor shall prove the location of utilities and shall be responsible for adequate protection from damage.



| No. | Description | By | Date (dd/mm/yy) |
|-----|---------------------------------------|----|-----------------|
| 0 | ISSUED FOR COSTING | BK | 10/07/19 |
| 1 | ISSUED FOR DESIGN DEVELOPMENT COSTING | BK | 23/01/20 |
| 2 | ISSUED FOR EARLY WORKS COORDINATION | BK | 20/05/20 |



EXISTING UTILITIES - SECTIONS

Alain C. Gonthier, P. Eng.
Director, Infrastructure Services

Paul Hussar
Project Manager

Asset Group
ISD

Des: NC Chk'd: BK

Dwn: NI Chk'd: JF

Utility Circulation No.:

Construction Inspector:

Scale: 1:300



NOTE:
The location of utilities is approximate only, the exact location should be determined by consulting the municipal authorities and utility companies concerned. The contractor shall prove the location of utilities and shall be responsible for adequate protection from damage.



| REVISIONS | No. | Description | By | Date (dd/mm/yy) |
|-----------|-----|---------------------------------------|----|-----------------|
| | 0 | ISSUED FOR COSTING | BK | 10/07/19 |
| | 1 | ISSUED FOR DESIGN DEVELOPMENT COSTING | BK | 23/01/20 |
| | 2 | ISSUED FOR EARLY WORKS COORDINATION | BK | 20/05/20 |

Drawing Frame: 700mm x 634mm City of Ottawa 2008 (Rev.0)

Per Date: Friday, May 22, 2020 9:55:29 AM

Last Saved: Friday, May 22, 2020 9:38:31 AM

Consultant's Information: \\m:\local\data\Proj\2019\190167700-OPL-LAC-Joint Facility\09_CAD\07_Sheets\190167700-Sections.dwg

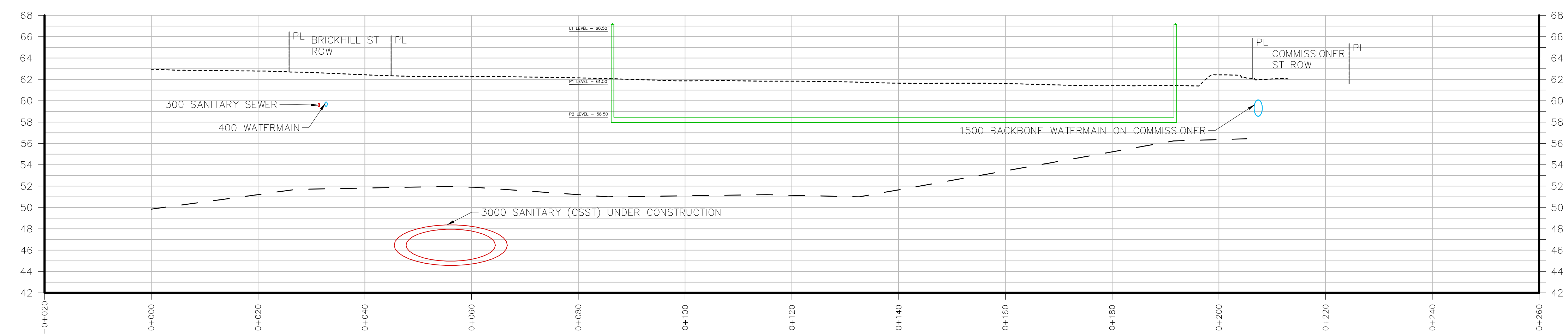

Section A-A

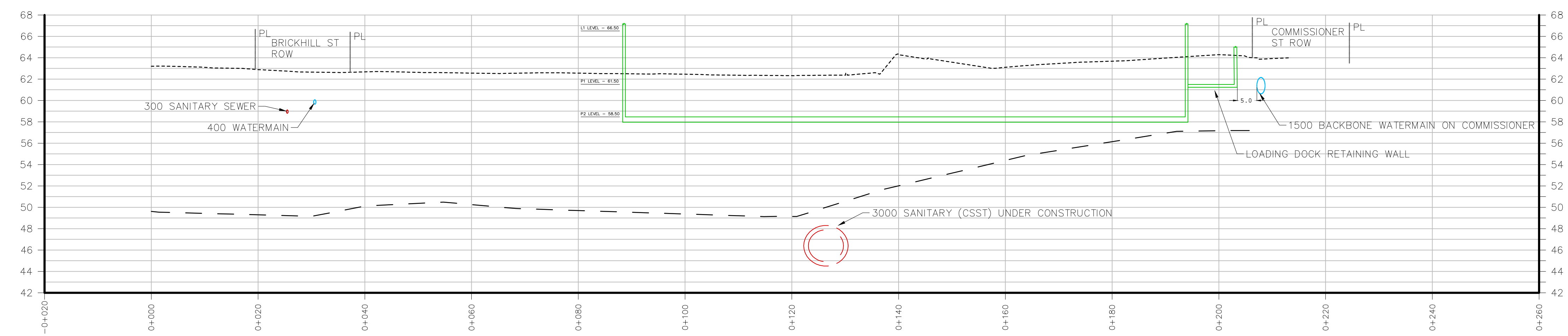

Section B-B

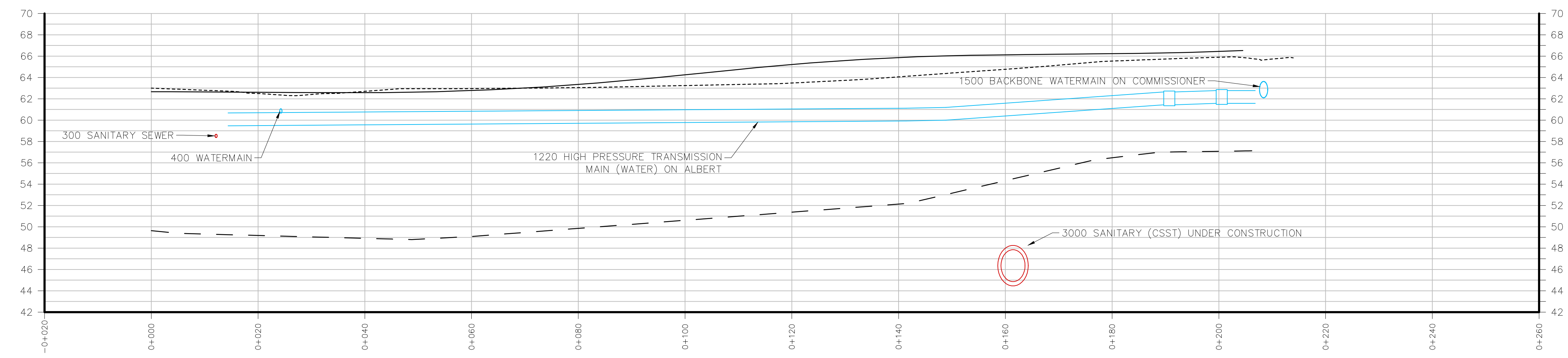

Section C-C

- ALBERT ST. DESIGN GRADE —————
- TOPO SURFACE - - - - -
- BEDROCK SURFACE - - - - -
- BUILDING FOUNDATION —————



EXISTING UTILITIES - SECTIONS

Alain C. Gonthier, P. Eng.
Director, Infrastructure Services

Paul Hussar
Project Manager

Asset Group
ISD

Des: NC Chk'd: BK

Dwn: NI Chk'd: JF

Utility Circulation No.:

Construction Inspector:

Scale: 1:300

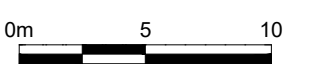

NOTE:
The location of utilities is approximate only, the exact location should be determined by consulting the municipal authorities and utility companies concerned. The contractor shall prove the location of utilities and shall be responsible for adequate protection from damage.



| REVISIONS | No. | Description | By | Date (dd/mm/yy) |
|-----------|-----|---------------------------------------|----|-----------------|
| | 0 | ISSUED FOR COSTING | BK | 10/07/19 |
| | 1 | ISSUED FOR DESIGN DEVELOPMENT COSTING | BK | 23/01/20 |
| | 2 | ISSUED FOR EARLY WORKS COORDINATION | BK | 20/05/20 |

- ALBERT ST. DESIGN GRADE
- TOPO SURFACE
- BEDROCK SURFACE
- BUILDING FOUNDATION

SECTION D-D

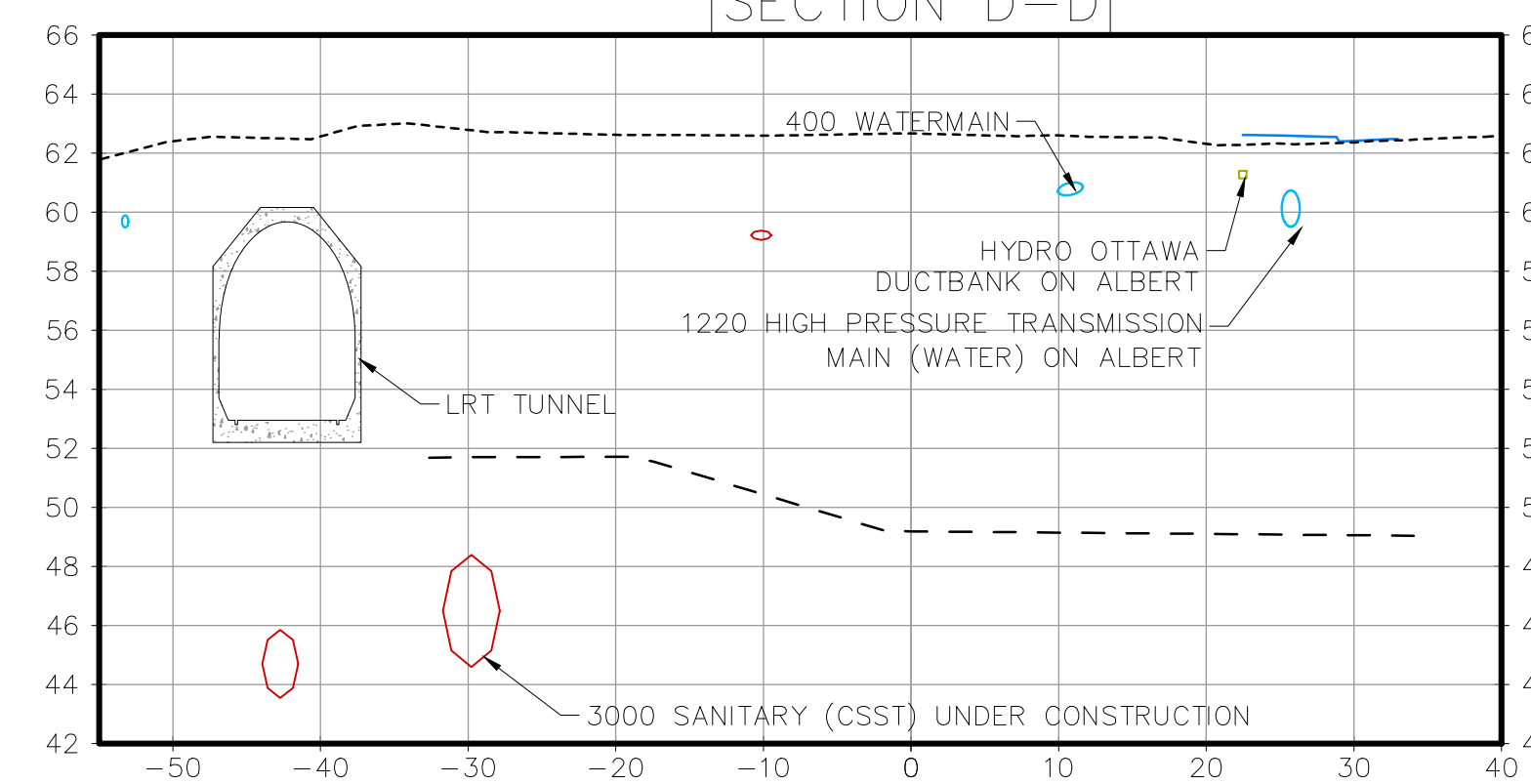

SECTION H-H

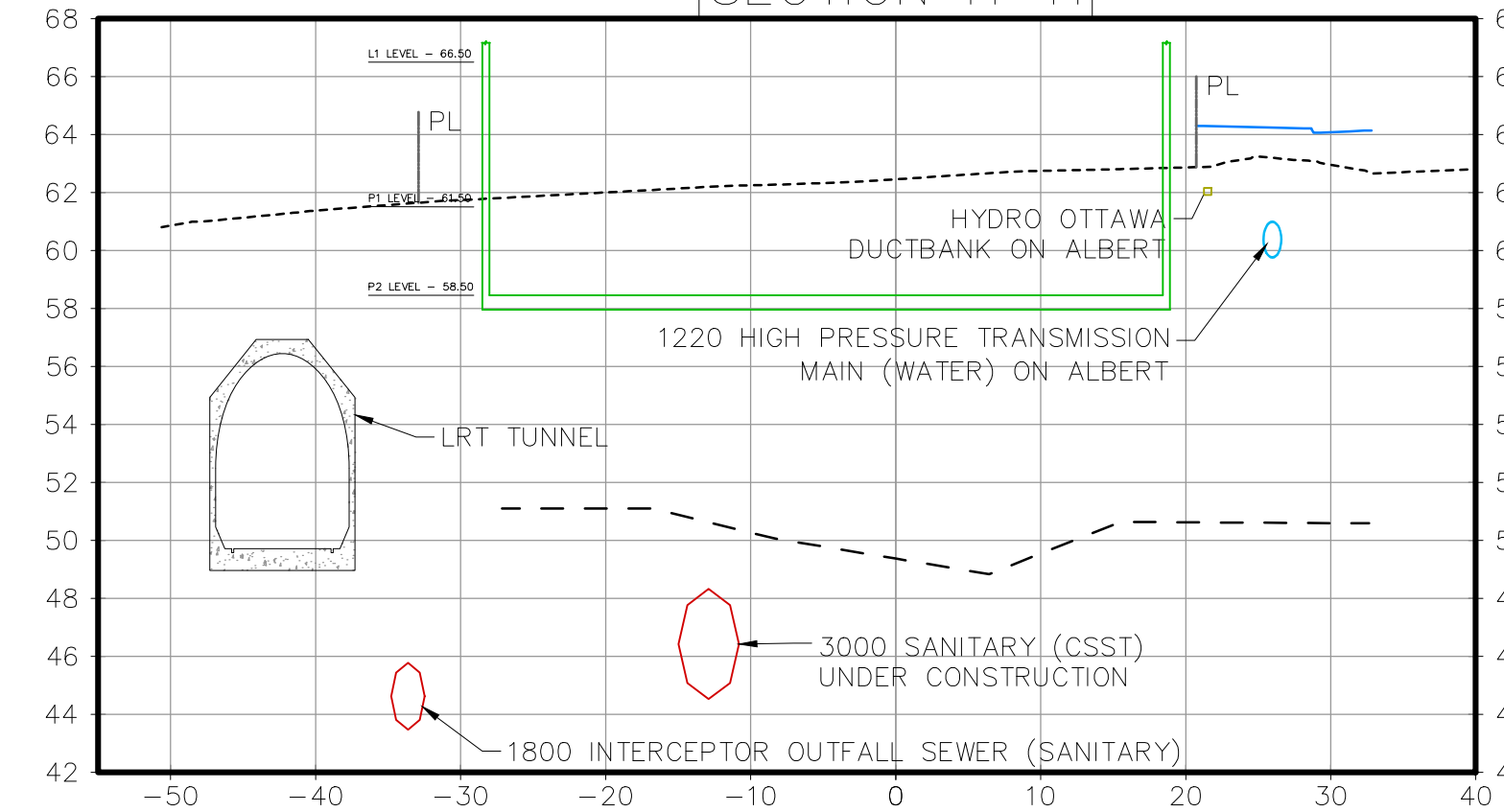

SECTION E-E

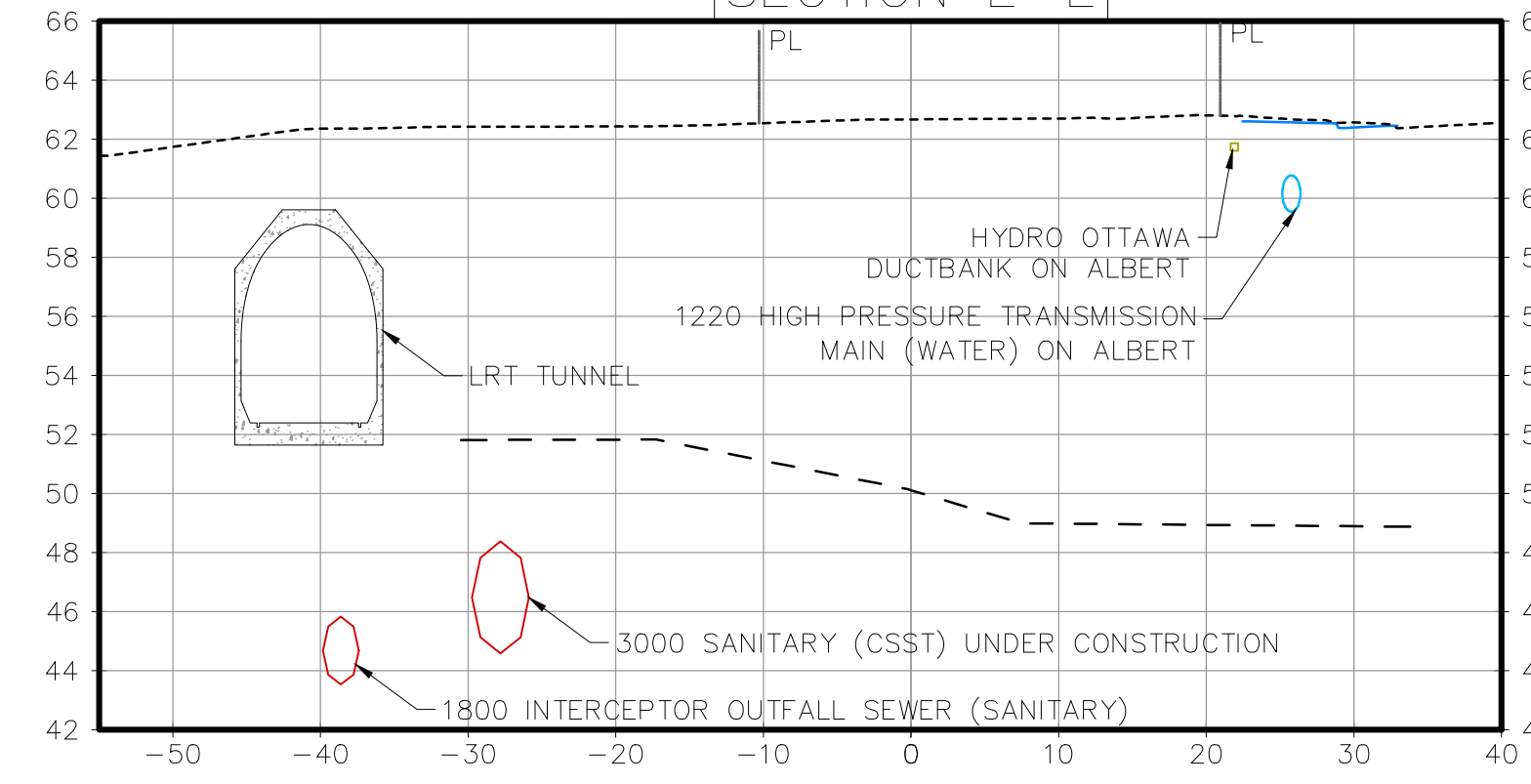

SECTION I-I

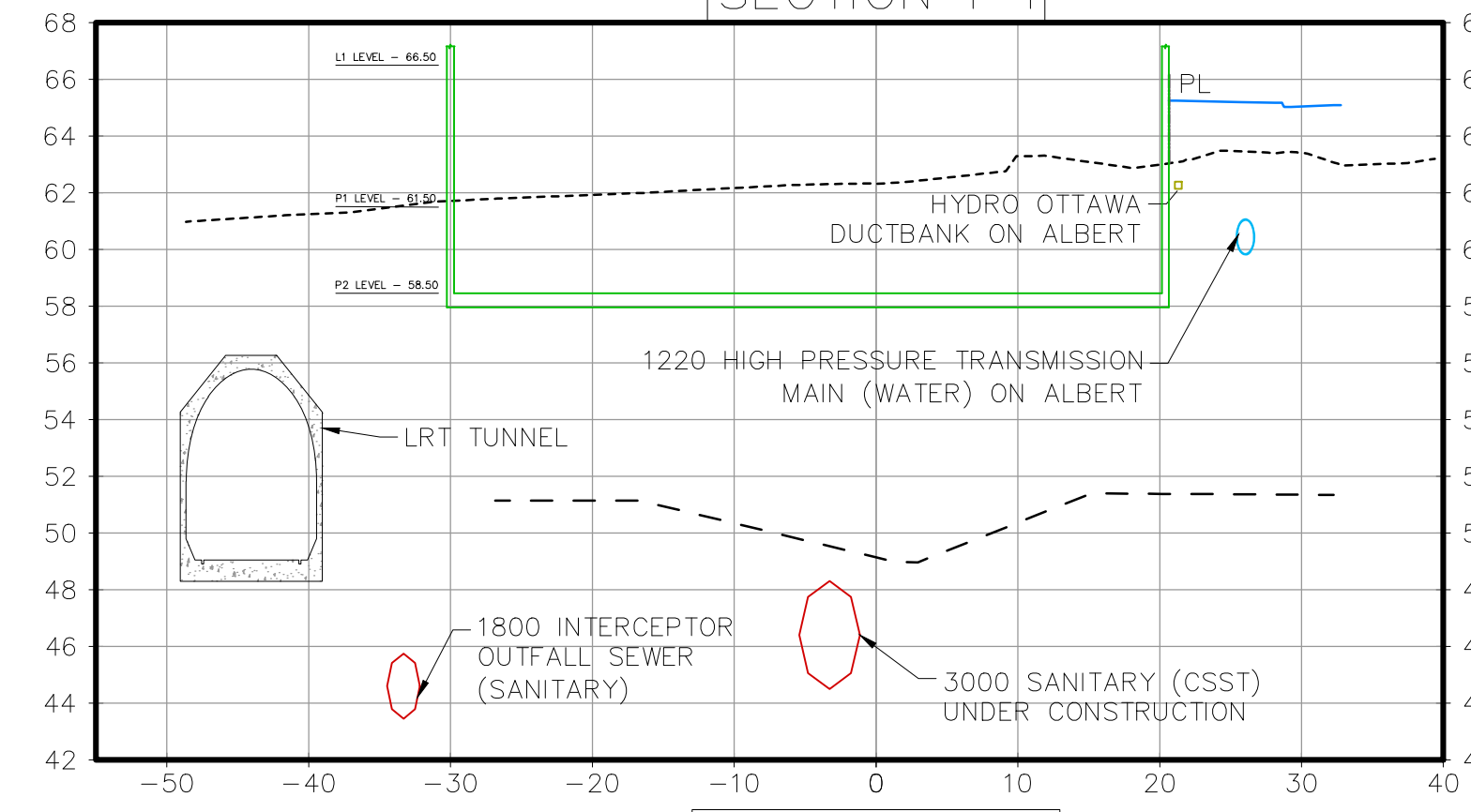

SECTION F-F

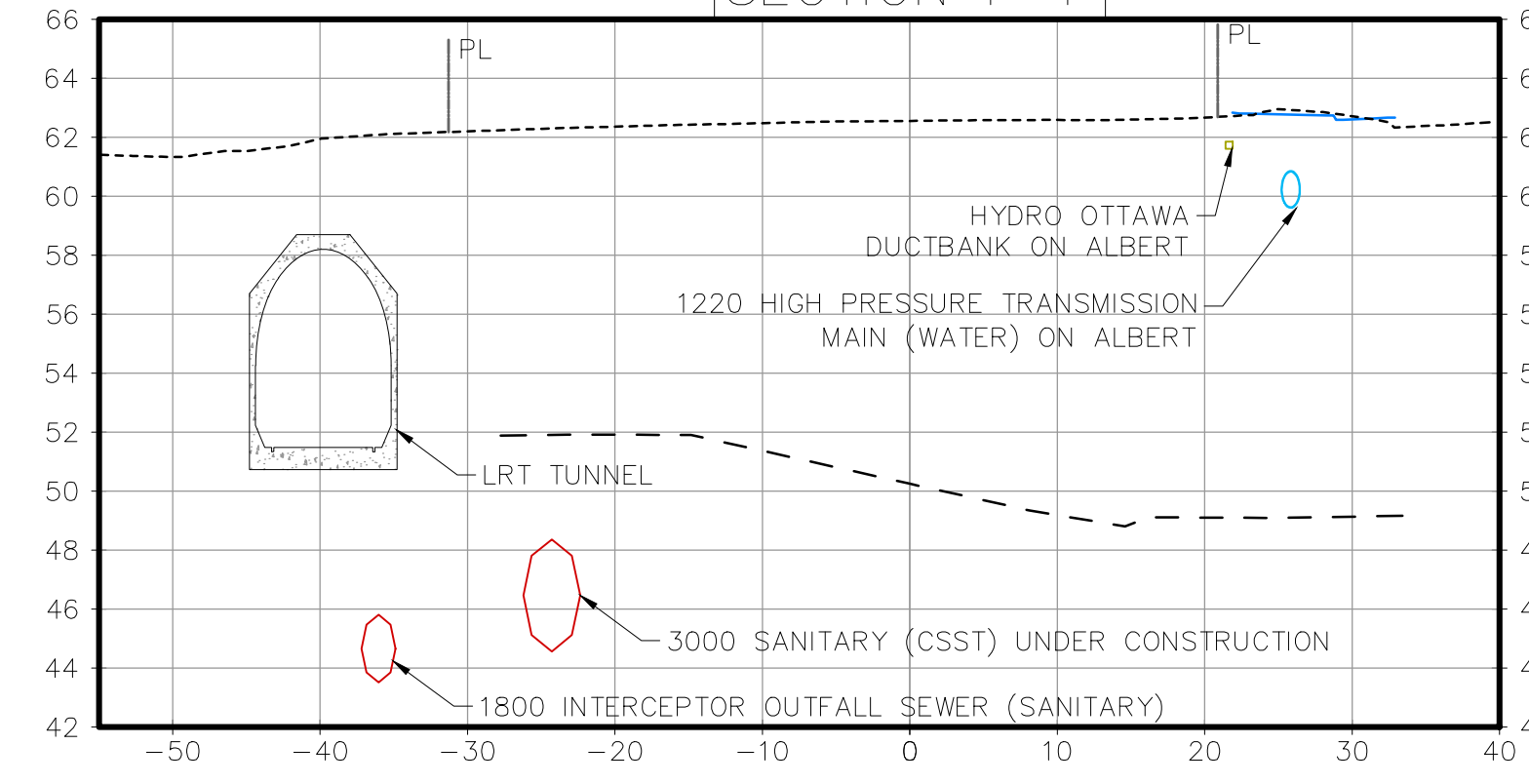

SECTION J-J

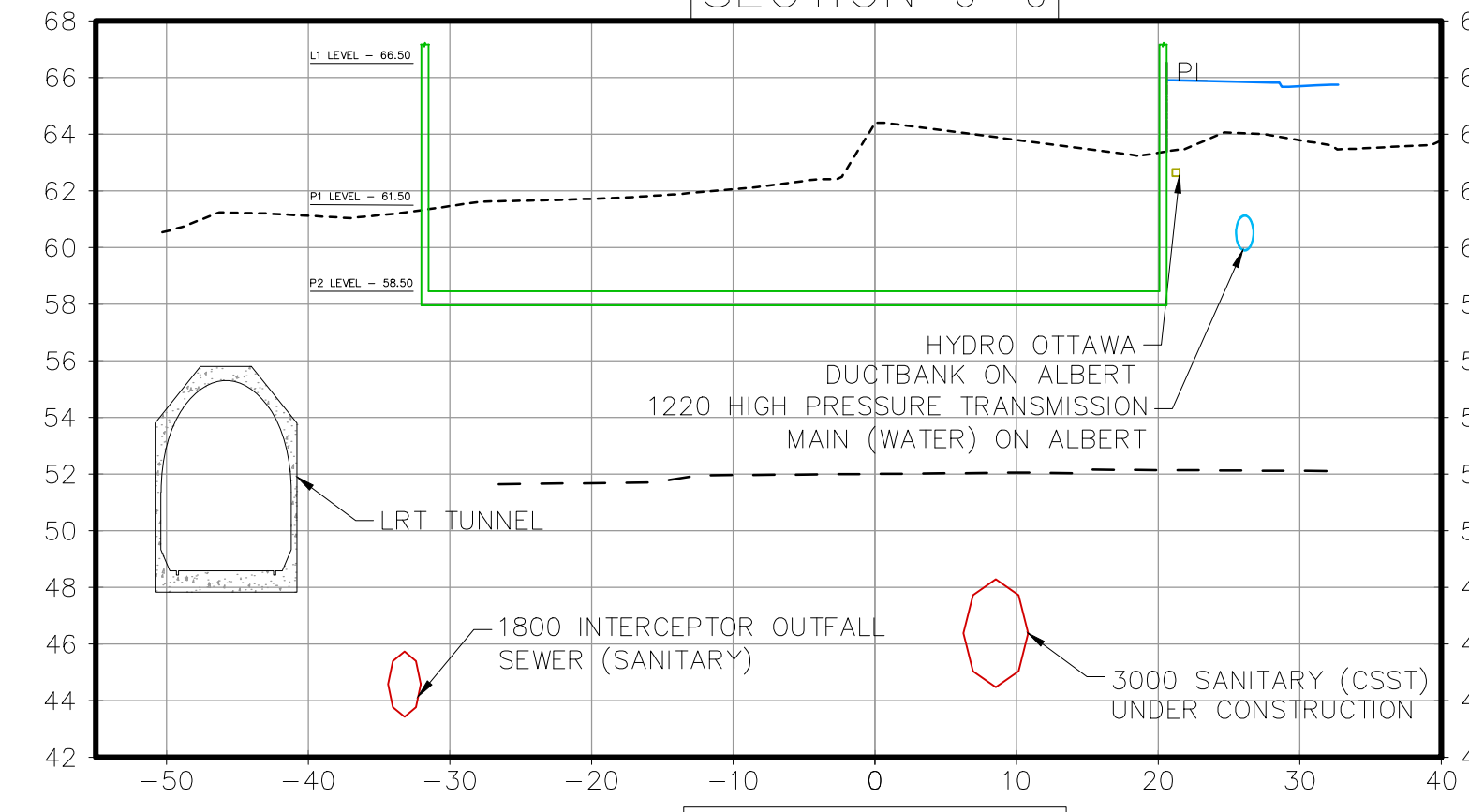

SECTION L-L

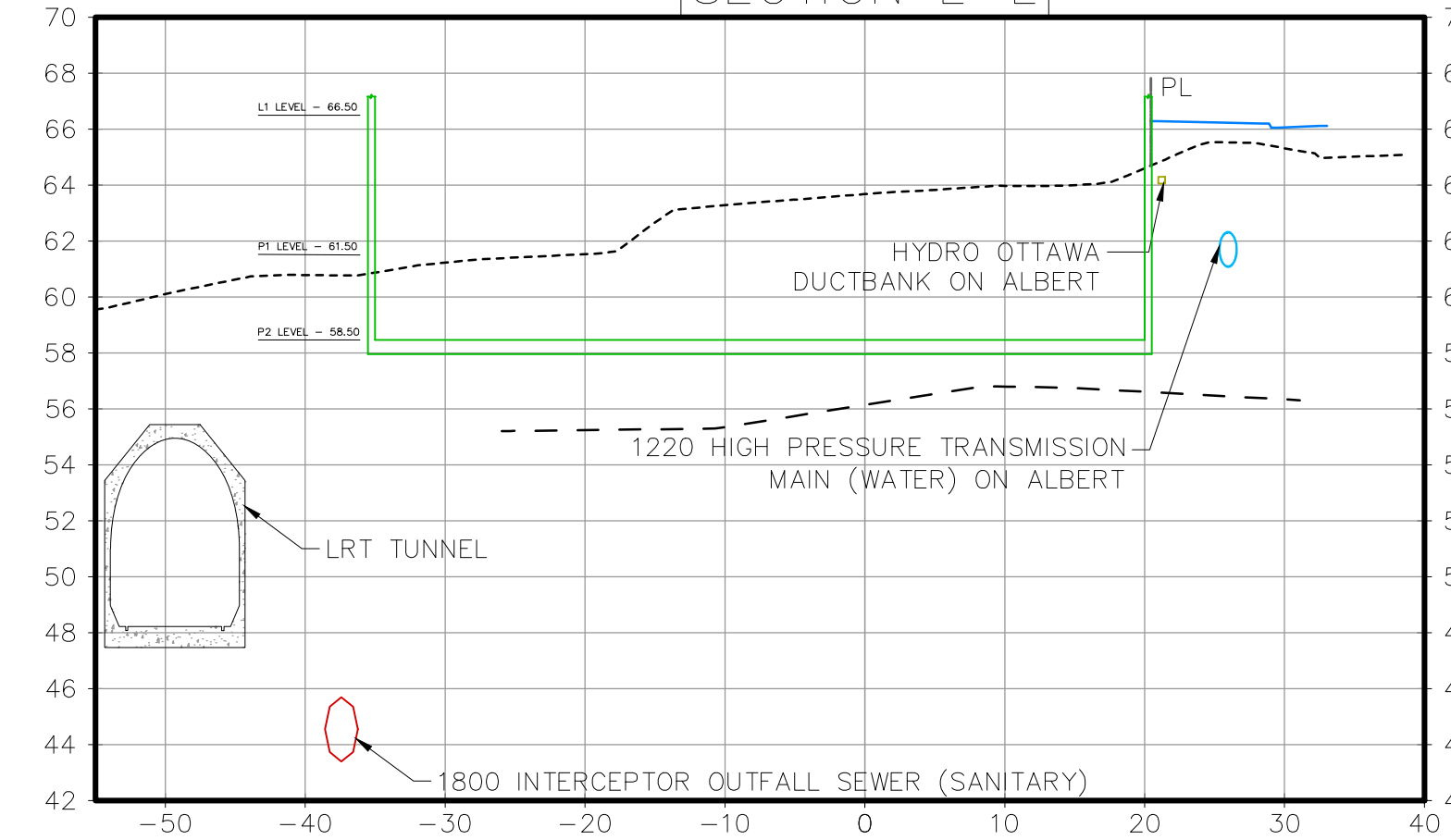

SECTION G-G

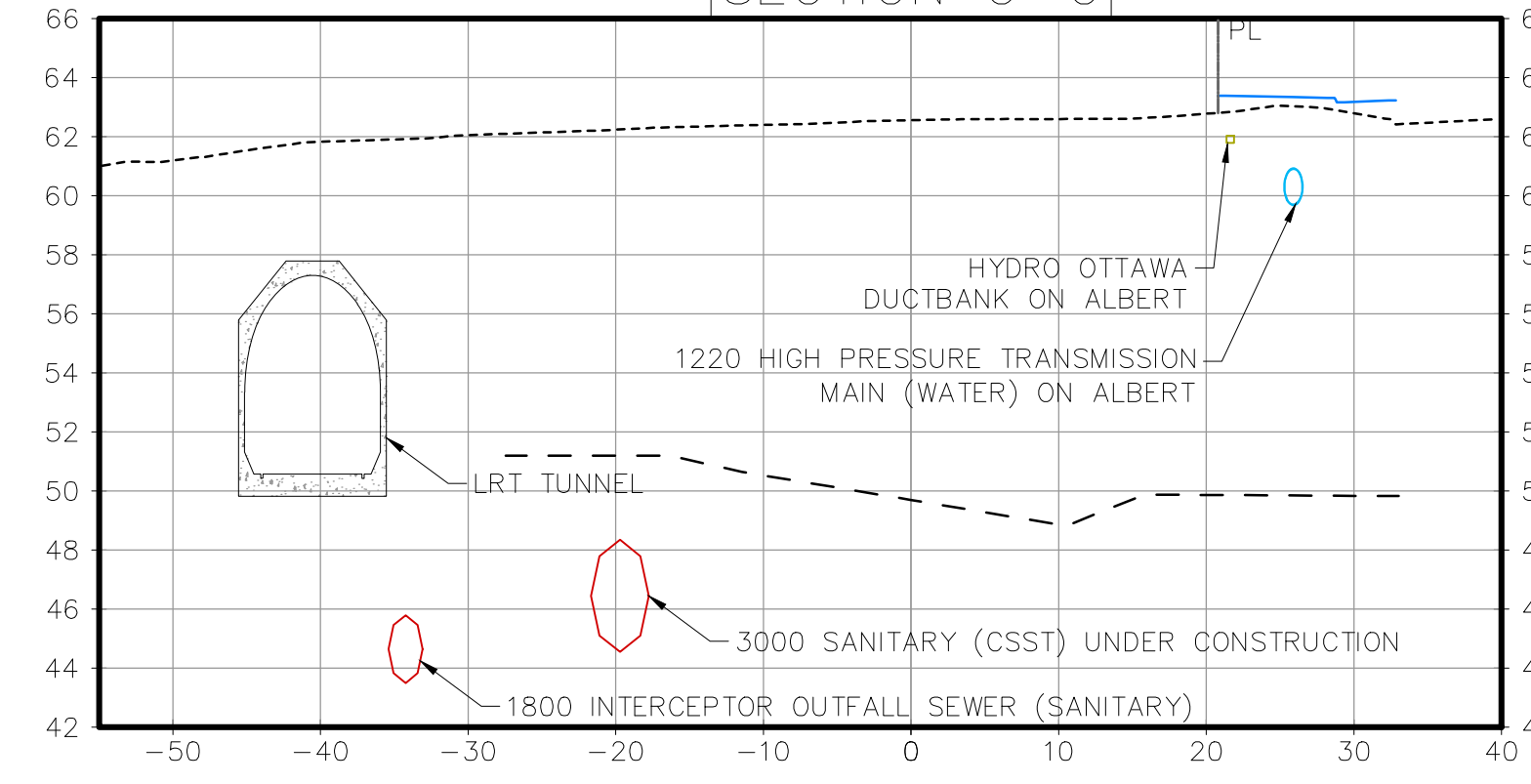

SECTION K-K

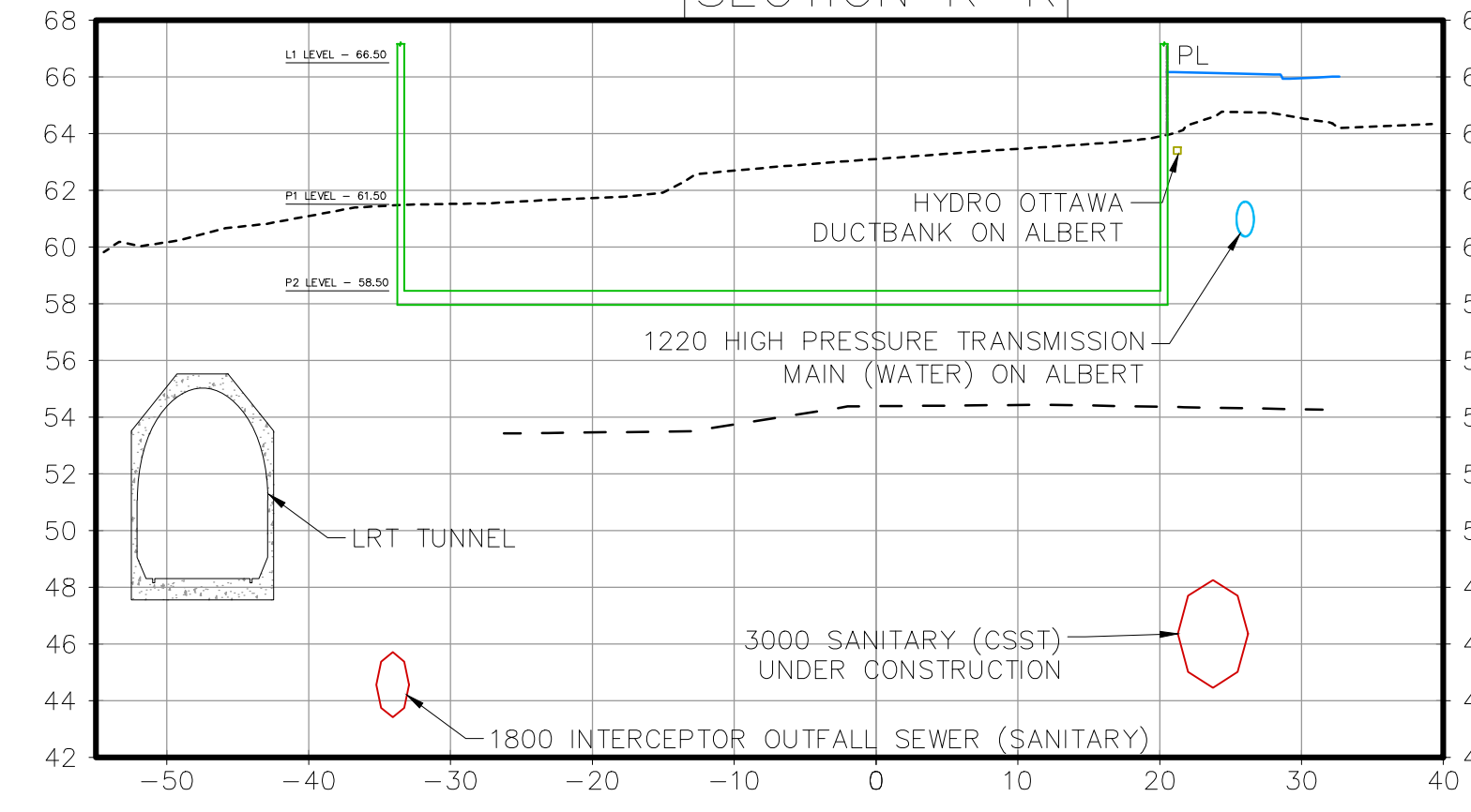

SECTION M-M

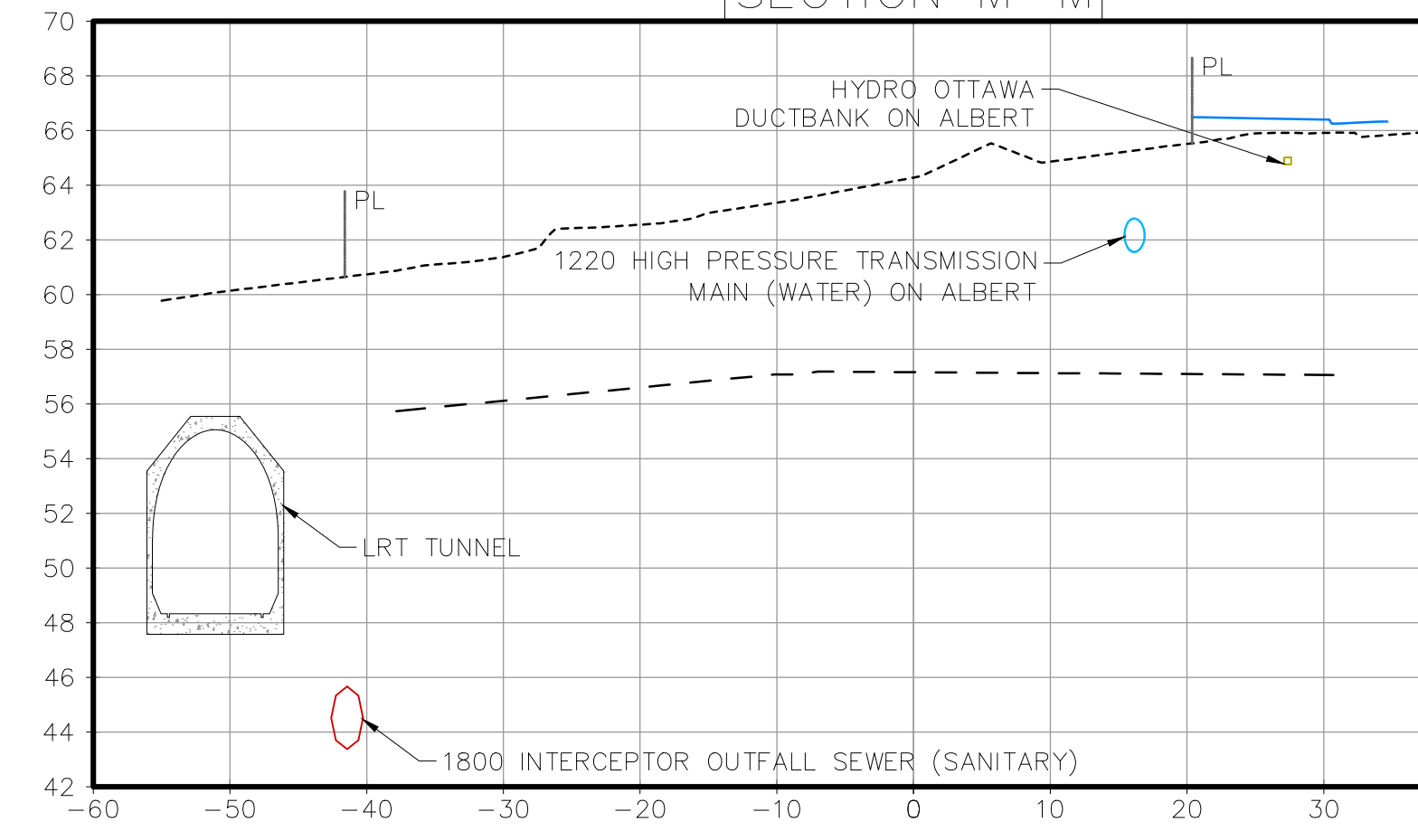

Drawing Frame: 700mm x 534mm City of Ottawa 2008 (Rev.0)
 Per Date: Friday, May 22, 2020 9:58:31 AM
 Last Saved: Friday, May 22, 2020 9:58:31 AM
 Consultant's Information: \\m:\local\asia\proj\2019\190167700-OPL-LAC-Joint Facility\09_CAD\07_Sheets\190167700-Sections.dwg

Appendix B

Water Demand and FUS Calculations

1. OPL-LAC Joint Facility Water Demands

| Design Parameter | Value (L/s) | Design Criteria |
|----------------------------------|-------------|-----------------------------------|
| Commercial Average Daily Demand | 0.32 | 28000 L/gross ha/day ¹ |
| Commercial Maximum Daily Demand | 0.48 | 1.5 x Average Daily ² |
| Commercial Maximum Hourly Demand | 0.87 | 1.8 x Max Daily ² |
| Fire Flow | 233.33 | Based on the FUS |

| Design Parameter | Value (L/s) | Boundary Conditions | |
|-----------------------------|-------------|-----------------------|----------------|
| | | Head (m) ³ | Pressure (kPa) |
| Average Daily Demand | 0.32 | 107 | 397.31 |
| | | 115.5 | 480.69 |
| Total Max Daily + Fire Flow | 233.81 | 98 | 309.02 |
| Max Hourly | 0.87 | 107 | 397.31 |
| Max Daily | 0.48 | 107 | 397.31 |

¹ City of Ottawa Water Design Guidelines (2010), Table 4.2, Other Commercial

² City of Ottawa Water Design Guidelines (2010), Table 4.2

³ The City of Ottawa Boundary Conditions for 200mm water service assumed to be connected to future 203mm water main, subsequent pressure measure from finished floor elevation (66.5m)

| | Scenario | | |
|--|----------------|------------|---------|
| | Max Day + Fire | Max Hourly | Max Day |
| Flow Demand (L/s) | 233.81 | 0.87 | 0.48 |
| Boundary Condition: Available Pressure under Future Conditions (kPa) | 309.02 | 397.31 | 397.31 |
| Residual Pressure at Service Tee including pipe losses (200mm diameter pipe) (kPa) | 242.75 | 397.27 | 397.28 |
| Minimum Allowable Pressure (kPa) | 140 | 276 | 345 |
| Pressure Check | OK | OK | OK |

| | | | | | |
|----------------|-------------------|-----------|---------------------|--|----------------------|
| Designed: | N. Chauvin | | Project: | OPL-LAC Joint Facility Proposed Servicing | |
| Checked: | B. Kipp | Date: | June 5, 2020 | | |
| Dwg Reference: | C-001 | File Ref: | 190167700 | Location: | 555 Albert St |
| | | | | Sheet No.: | 1 of 1 |

2. OPL-LAC Fire Underwriters Survey Calculations

Project OPL-LAC Joint Facility
Project # 190167700
Address 555 Albert St, Ottawa
Designed B Kipp
Date 2-Jun-20

Per Fire Underwriters Survey, Water Supply for Public Fire Protection, 1999, as modified and amended by the City of Ottawa Design Guidelines, Water Distribution, Appendix H "Protocol to Clarify the Application of the Fire Flow Calculation Method Published by Fire Underwriters Survey (FUS)"

Assumptions:

The new OPL-LAC Joint Facility is a standalone building. There are no existing adjacent buildings which are closer than 45m. The P1 level was assumed to be less than 50% below grade, and therefore its area is included in the total floor area calculation. The P2 level is more than 50% below grade and is therefore excluded.

Calculation:

1. Determine Estimated Fire Flow based on Building Floor Area

$$F = 220 C \sqrt{A}$$

F= Required flow in litres / minute

A= Total floor area in m²

C= Coefficient related to Construction

= 1.5 for wood frame construction

= 1.0 for ordinary construction

= 0.8 for non-combustible construction

= 0.6 for fire-resistive construction

C=

| Floor | Area |
|-------|-------|
| P1* | 5499 |
| 1 | 4179 |
| 2 | 3729 |
| 3 | 3802 |
| 4 | 3833 |
| 5 | 2199 |
| Total | 23241 |

**P2 area used to be conservative.*

Confirmed that P1 level has a smaller area than P2. Area is to outer edge of foundation.

Non-combustible: use sum of all floor areas

$$A = 23241 \text{ m}^2$$

$$F = 26831.2 \text{ L/min}$$

Round to nearest 1000 L/min= **27000.0** L/min

2. Adjust flow based on Fire hazard and contents

| | | |
|---|---------------------|------|
| A | Non-combustible | -25% |
| B | Limited Combustible | -15% |
| C | Combustible | 0% |
| D | Free Burning | 15% |
| E | Rapid Burning | 25% |

Type of Construction (A,B,C,D) **B** (ISO Class: C-2 limited combustibility)
 Adjustment Factor -15%

| | |
|---------------------------|----------------------|
| Flow From 1. | 27000.0 L/min |
| Adjusted Flow | 22950.0 L/min |
| Minimum Flow (2000 L/min) | 22950.0 L/min |
| Flow | 22950.0 L/min |

3. Reduce flow from No. 2. based on automatic sprinkler protection

| | |
|---|-------------------|
| Flow from 2. | 22950.0 L/min |
| Automatic Sprinkler Protection (yes/no) | Yes |
| % of building covered by sprinklers | 100% |
| Reduction | 30% (Maximum 30%) |
| Water supply is standard (yes/no) | Yes |
| Additional Reduction | 10% (Maximum 10%) |
| Sprinkler System is fully supervised (yes/no) | No |
| Additional Reduction | 0% (Maximum 10%) |
| Total Reduction | 40% |

Flow after Sprinkler Reduction **13770.0** L/min

4. Adjacent Structures / Fire Separation with other buildings

Flow from 3. 13770.0 L/min

Figure 1: Adjacent Buildings & distances to hydrants



Exposure charge based on Table G5:

Note: The nearest corner of the Fleet St Pumping Station is 41m from the OPL-LAC Joint Facility. However the Pumping Station is lower than the proposed OPL-LAC Joint Facility, so does not have an exposed face. For the purposes of this calculation, in order to be conservative, it has been assumed that 1 storey of the Fleet St Pumping Station will overlap with the P1/Level 1 storeys of the OPL-LAC Joint Facility.

| Side | Construction Type | Storeys | Length (m) | LH Factor |
|-------|--|---------|------------|-----------|
| North | N/A | 0 | 0 | 0 |
| East | N/A | 0 | 0 | 0 |
| South | N/A | 0 | 0 | 0 |
| West | Fire-resistive with unprotected openings | 1 | 31 | 31 |

| Side | Separation Distance (m) | Exposure Charge |
|-------|-------------------------|-----------------|
| North | >45 | 0% |
| East | >45 | 0% |
| South | >45 | 0% |
| West | 41 | 5% |

Note: Table G5 of City of Ottawa Design Guidelines, Water Distribution, Appendix H "Protocol to Clarify the Application of the Fire Flow Calculation Method Published by Fire Underwriters Survey (FUS)", states that for separation distances between 30.1m and 45m, the exposure charge shall be a maximum of 5%, regardless of the length-height factor of exposed wall of the adjacent structure and the type of construction of the adjacent structure.

Cumulative Increase (Max 75%) 5%

| | |
|--|---------------|
| Flow Increased for Adjacent Structures | 14458.5 L/min |
| Maximum Permitted Flow (45 000 L/min) | 14458.5 L/min |
| Minimum Permitted Flow (2 000 L/min) | 14458.5 L/min |

| | |
|--|-------------|
| Required Fire Flow (rounded to nearest 1000 L/m) | 14000 L/min |
| | 233 L/s |

Confirmation that required fire flow is available from hydrants within 150m of building:

| Hydrant | Distance from building (m) | Class | Contribution to required fire flow (L/m) |
|----------------|----------------------------|-------|--|
| 1 (existing) | 65 | AA* | 5700 |
| 2 (existing) | 60 | AA* | 5700 |
| 3 (existing) | 120 | AA* | 3800 |
| 4* (proposed) | 45 | AA* | 5700 |
| Available Flow | | | 20900 |

Required Flow (FUS calc)

14000.0 L/min

Note*: Hydrant 4 (new) will be installed as part of Albert-Slater Project. It will be installed within 45m of the OPL-LAC building to satisfy Building Code requirements.

3. OPL-LAC Domestic Water Demands

Project Name OPL - LAC Joint Facility
 Project Number 1901677
 Site Address 555 Albert St, Ottawa
 Completed By BK
 Date 6/2/2020

Excerpt from City of Ottawa Water Design Guidelines (2010), Table 4.2

| Demand Type | Amount | Units |
|---------------------------------------|--------|--------------------------|
| AVERAGE DAILY DEMAND | | |
| Residential | 350 | L/person/day |
| Industrial - Light | 35000 | L/gross ha/d |
| Industrial - Heavy | 55000 | L/gross ha/d |
| Commercial & Institutional | | |
| Shopping Centre | 2500 | L/(100m ² /d) |
| Hospital | 900 | L/(bed/day) |
| School | 70 | L/(Student/day) |
| Trailer Park no Hook-up | 340 | L/(space/day) |
| Trailer Park with Hook Up | 800 | L/(space/day) |
| Campgrounds | 225 | L/(Campsite/day) |
| Mobile Home Parks | 1000 | L/(space/day) |
| Motels | 150 | L/(bed-space/day) |
| Hotels | 225 | L/(bed-space/day) |
| Tourist Commercial | 28000 | L/gross ha/d |
| Other Commercial | 28000 | L/gross ha/d |

| MAXIMUM DAILY DEMAND | | | |
|-----------------------------|-----|------------|--------------|
| Residential | 2.5 | x avg. day | L/person/day |
| Industrial | 1.5 | x avg. day | L/gross ha/d |
| Commercial | 1.5 | x avg. day | L/gross ha/d |
| Institutional | 1.5 | x avg. day | L/gross ha/d |

| MAXIMUM HOURLY DEMAND | | | |
|------------------------------|-----|-----------|--------------|
| Residential | 2.2 | x max day | L/person/day |
| Industrial | 1.8 | x max day | L/gross ha/d |
| Commercial | 1.8 | x max day | L/gross ha/d |
| Institutional | 1.8 | x max day | L/gross ha/d |

| | Category | Value | |
|------------------------------------|------------------|-------|--------------|
| Class of Building (A-N) | Other Commercial | 28000 | L/gross ha/d |
| Quantity (persons/spaces/gross ha) | Gross Hectare | 0.97 | ha |
| Peaking Factor- Max Daily | Commercial | 1.5 | x avg. day |
| Peaking Factor- Max Hourly | Commercial | 1.8 | x max day |

| | | |
|-----------------------|---------|-------|
| Average Daily Demand | 27160.0 | L/day |
| Maximum Daily Demand | 40740.0 | L/day |
| Maximum Hourly Demand | 73332.0 | L/day |

4a. OPL-LAC Water Demand Calculations

Scenario: Max Day + Fire

$P_{\text{Road}} = 309.02$ (kPa) Minimum pressure under Future Conditions including max day + fire
 $P_{\text{Road}} = 44.82$ (psi)

Proposed Service

Length

$L = 22.4$ (m)
 73 (ft)

Head Loss

$$P_d = \frac{4.52Q^{1.85}}{C^{1.85}d^{4.87}}$$

Size

$d = 200$ (mm)
 8 (in)

$$P = 0.434hSG$$

SG= specific gravity of water
 $= 1$

$C = 110$

Flow

$Q = 0.2338$ (m³/s)
 3706 (USG/min)

$P_d = 0.130788624$ (psi)
 $h = 0.301356$ (ft/ft)
 22.1469 (ft)

Velocity

$$V = \frac{1.274Q}{d^2}$$

$V = 7.45$ (m/s)

Pressure Loss

$P_{\text{ROAD}} = 44.82$ (psi)

$P_L = 9.61$ (psi)

$P_{\text{AT METER}} = 35.21$ (psi)

$P_{\text{AT METER}} = 242.8$ (KPa)

4b. OPL-LAC Water Demand Calculations

Scenario: May Hourly

$P_{\text{Road}} = 397.31$ (kPa) Minimum pressure under max hourly conditions
 $P_{\text{Road}} = 57.62$ (psi)

Proposed Service

Length

$L = 22.4$ (m)
 73 (ft)

Head Loss

$$P_d = \frac{4.52Q^{1.85}}{C^{1.85}d^{4.87}}$$

Size

$d = 200$ (mm)
 8 (in)

$$P = 0.434hSG$$

SG= specific gravity of water
 $= 1$

$C = 110$

Flow

$Q = 0.0009$ (m³/s)
 14 (USG/min)

$P_d = 4.16212E-06$ (psi)
 $h = 0.000010$ (ft/ft)
 0.0007 (ft)

Velocity

$$V = \frac{1.274Q}{d^2}$$

$V = 0.03$ (m/s)

Pressure Loss

$P_{\text{ROAD}} = 57.62$ (psi)

$P_L = 0.0003$ (psi)

$P_{\text{AT METER}} = 57.62$ (psi)

$P_{\text{AT METER}} = 397.27$ (kpa)

4c. OPL-LAC Water Demand Calculations

Scenario: Max Daily

$P_{\text{Road}} = 397.31$ (kPa) Minimum pressure under max daily conditions
 $P_{\text{Road}} = 57.62$ (psi)

Proposed Service

Length

$L = 22.4$ (m)
 73 (ft)

Head Loss

$$P_d = \frac{4.52Q^{1.85}}{C^{1.85}d^{4.87}}$$

Size

$d = 200$ (mm)
 8 (in)

$$P = 0.434hSG$$

SG= specific gravity of water
 $= 1$

$C = 110$

Flow

$Q = 0.0005$ (m³/s)
 8 (USG/min)

$P_d = 1.40301E-06$ (psi)
 $h = 0.000003$ (ft/ft)
 0.0002 (ft)

Velocity

$$V = \frac{1.274Q}{d^2}$$

$V = 0.02$ (m/s)

Pressure Loss

$P_{\text{ROAD}} = 57.62$ (psi)

$P_L = 0.0001$ (psi)

$P_{\text{AT METER}} = 57.62$ (psi)

$P_{\text{AT METER}} = 397.28$ (kpa)

Diamond Schmitt Architects

384 Adelaide Street West
Suite 300
Toronto, Ontario
M5V 1R7 Canada

Tel: 416 862 8800
Fax: 416 862 5508
info@dsai.ca
www.dsai.ca

KWC Architects Inc.

201-383 Parkdale Avenue
Ottawa, Ontario
K1Y 4R4 Canada

Tel: 613 238 2117
Fax: 613 238 6595
Kwc@kwc-arch.com
www.kwc-arch.com

25 May 2020

To: **James Fookes, P.Eng.**
Lead Civil Engineer
Morrison Hershfield
200 – 2932 Baseline Road
Ottawa, ON K2H 1B1

Subject: **Ottawa Public Library – Library and Archives Canada Joint Facility**, 555 Albert Street
Information requested for Fire Underwriters Survey assessment

The following information is provided for use in the estimation of water demands for fire fighting, as required for Site Plan Approval submission. The class of construction and occupancy type have been assessed in accordance with the City of Ottawa/NRC *Protocol to Clarify the Application of the Fire Flow Calculation Method Published by the Fire Underwriters Survey (FUS), 2018*.

1. Floor area per storey:

| | | | |
|----------|---|----------------------|-----------------------------|
| Level P2 | = | 5,165 m ² | (entirely below grade) |
| Level P1 | = | 5,020 m ² | (less than 50% below grade) |
| Level 1 | = | 4,179 m ² | |
| Level 2 | = | 3,729 m ² | |
| Level 3 | = | 3,802 m ² | |
| Level 4 | = | 3,833 m ² | |
| Level 5 | = | 2,199 m ² | |

2. Type of construction: Class 3 (non-combustible)
3. Occupancy type: Class C-2 (limited combustibility)
4. Sprinkler protection: The building will be provided with complete automatic sprinkler protection.
5. Supervision of sprinkler protection: The sprinkler system will not be “fully supervised” under the definition of the National Fire Protection Association (NFPA) Life Safety Code.

Yours sincerely,



Ralph Wiesbrock, OAA, FRAIC, LEED AP
Partner / Principal

Noah Chauvin

From: Bryan Kipp
Sent: Tuesday, June 2, 2020 10:28 AM
To: Noah Chauvin
Subject: FW: Water Pressure / Flow Boundary Condition Request - OPL-LAC 555 Albert St
Attachments: 555 Slater May 2020.pdf

FYI

From: Valic, Jessica [mailto:jessica.valic@ottawa.ca]
Sent: Tuesday, June 2, 2020 9:31 AM
To: Bryan Kipp <BKipp@morrisonhershfield.com>
Cc: Oram, Cody <Cody.Oram@ottawa.ca>; James Fookes <JFookes@morrisonhershfield.com>; rwiesbrock@kwc-arch.ca
Subject: RE: Water Pressure / Flow Boundary Condition Request - OPL-LAC 555 Albert St

Good Morning Bryan,

Boundary conditions are below and attached.

Can you please clarify why 0.6ha was used for the gross ha? The parcel size is listed as 1.13ha on the pre-consult form and a quick measurement on GeoOttawa gives an area greater than 1ha.

The following are boundary conditions, HGL, for hydraulic analysis at 555 Slater (zone 1W) assumed to be connected to a future 203mm watermain to be installed as part of the Albert/Slater reconstruction (see attached PDF for location). Please note if the proposed size of the future watermain is different and/or if the location of the service connection changes, then revised boundary conditions would be required.

Minimum HGL = 107.0m

Maximum HGL = 115.5m

MaxDay + FireFlow (233 L/s) = 98.0m

These are for current conditions and are based on computer model simulation.

Disclaimer: The boundary condition information is based on current operation of the city water distribution system. The computer model simulation is based on the best information available at the time. The operation of the water distribution system can change on a regular basis, resulting in a variation in boundary conditions. The physical properties of watermains deteriorate over time, as such must be assumed in the absence of actual field test data. The variation in physical watermain properties can therefore alter the results of the computer model simulation.

Please do not hesitate to contact me with any questions/concerns.

Regards,

Jessica Valic, E.I.T.

Engineering Intern

Planning, Infrastructure and Economic Development Department - Services de la planification, de l'infrastructure et du développement économique

Development Review - Central

City of Ottawa | Ville d'Ottawa

110 Laurier Avenue West Ottawa, ON | 110, avenue. Laurier Ouest. Ottawa (Ontario) K1P 1J1

613.580.2424 ext./poste 15672

jessica.valic@ottawa.ca

From: Bryan Kipp <BKipp@morrisonhershfield.com>

Sent: May 25, 2020 6:25 PM

To: Valic, Jessica <jessica.valic@ottawa.ca>

Cc: Oram, Cody <Cody.Oram@ottawa.ca>; James Fookes <JFookes@morrisonhershfield.com>; rwiesbrock@kwc-arch.ca

Subject: RE: Water Pressure / Flow Boundary Condition Request - OPL-LAC 555 Albert St

CAUTION: This email originated from an External Sender. Please do not click links or open attachments unless you recognize the source.

ATTENTION : Ce courriel provient d' un expéditeur externe. Ne cliquez sur aucun lien et n' ouvrez pas de pièce jointe, excepté si vous connaissez l' expéditeur.

Hi Jessica,

Please find the domestic water demand calculations attached. A consumption rate for 'other commercial' was used, with a gross area of 0.6 ha.

The calculated demands were strictly based on consumption rate and gross area. Fixture counts, and the expected number of employees and members of the public that will use the building on a daily basis, are not confirmed at this time.

Regards,
Bryan

Bryan Kipp, P.Eng.

Municipal Engineer

BKipp@morrisonhershfield.com



MORRISON HERSHFIELD

People • Culture • Capabilities

200 – 2932 Baseline Road | Ottawa, ON K2H 1B1 Canada

Dir: 613 690 3722 | Office: 613 739 2910 | Fax: 613 739 4926

morrisonhershfield.com

From: Valic, Jessica [<mailto:jessica.valic@ottawa.ca>]

Sent: Monday, May 25, 2020 9:33 AM

To: Bryan Kipp <BKipp@morrisonhershfield.com>

Cc: Oram, Cody <Cody.Oram@ottawa.ca>; James Fookes <JFookes@morrisonhershfield.com>; rwiesbrock@kwc-arch.ca

Subject: RE: Water Pressure / Flow Boundary Condition Request - OPL-LAC 555 Albert St

Thank you Bryan. Boundary conditions have been requested and will be forwarded on receipt.

Concerning the provided demands, can you please confirm which consumption rate was used from Table 4.2? Have you used hours of operation in your calculated demands? Specific fixture counts?

Please do not hesitate to contact me with any questions/concerns.

Regards,

Jessica Valic, E.I.T.

Engineering Intern

Planning, Infrastructure and Economic Development Department - Services de la planification, de l'infrastructure et du développement économique

Development Review - Central

City of Ottawa | Ville d'Ottawa

110 Laurier Avenue West Ottawa, ON | 110, avenue. Laurier Ouest. Ottawa (Ontario) K1P 1J1

613.580.2424 ext./poste 15672

jessica.valic@ottawa.ca

From: Bryan Kipp <BKipp@morrisonhershfield.com>

Sent: May 15, 2020 6:25 PM

To: Valic, Jessica <jessica.valic@ottawa.ca>

Cc: Oram, Cody <Cody.Oram@ottawa.ca>; James Fookes <JFookes@morrisonhershfield.com>; rwiesbrock@kwc-arch.ca

Subject: RE: Water Pressure / Flow Boundary Condition Request - OPL-LAC 555 Albert St

CAUTION: This email originated from an External Sender. Please do not click links or open attachments unless you recognize the source.

ATTENTION : Ce courriel provient d' un expéditeur externe. Ne cliquez sur aucun lien et n' ouvrez pas de pièce jointe, excepté si vous connaissez l' expéditeur.

Hi Jessica,

Please find the FUS calculation attached.

Regards,

Bryan

Bryan Kipp, P.Eng.

Municipal Engineer

BKipp@morrisonhershfield.com



200 – 2932 Baseline Road | Ottawa, ON K2H 1B1 Canada
Dir: 613 690 3722 | Office: 613 739 2910 | Fax: 613 739 4926
morrisonhershfield.com

From: Valic, Jessica [<mailto:jessica.valic@ottawa.ca>]

Sent: Friday, May 15, 2020 2:09 PM

To: Bryan Kipp <BKipp@morrisonhershfield.com>

Cc: Oram, Cody <Cody.Oram@ottawa.ca>; James Fookes <JFookes@morrisonhershfield.com>; rwiesbrock@kwc-arch.ca

Subject: RE: Water Pressure / Flow Boundary Condition Request - OPL-LAC 555 Albert St

Hi Bryan,

Can you please forward the FUS calculation sheet for review?

Thank you.

Please do not hesitate to contact me with any questions/concerns.

Regards,

Jessica Valic, E.I.T.

Engineering Intern

Planning, Infrastructure and Economic Development Department - Services de la planification, de l'infrastructure et du développement économique

Development Review - Central

City of Ottawa | Ville d'Ottawa

110 Laurier Avenue West Ottawa, ON | 110, avenue. Laurier Ouest. Ottawa (Ontario) K1P 1J1

613.580.2424 ext./poste 15672

jessica.valic@ottawa.ca

From: Bryan Kipp <BKipp@morrisonhershfield.com>

Sent: May 14, 2020 9:17 PM

To: Oram, Cody <Cody.Oram@ottawa.ca>

Cc: James Fookes <JFookes@morrisonhershfield.com>; Ralph Wiesbrock <rwiesbrock@kwc-arch.ca>

Subject: Water Pressure / Flow Boundary Condition Request - OPL-LAC 555 Albert St

CAUTION: This email originated from an External Sender. Please do not click links or open attachments unless you recognize the source.

ATTENTION : Ce courriel provient d' un expéditeur externe. Ne cliquez sur aucun lien et n' ouvrez pas de pièce jointe, excepté si vous connaissez l' expéditeur.

Hi Cody,

Thanks for meeting with us this morning. As you are aware, Morrison Hershfield has been retained by Diamond Schmitt Architects in joint venture with KWC Architects to carry out Civil engineering services for the new OPL-LAC Joint Facility at 555 Albert St (File No: PC2020-0106).

The purpose of this email is to request boundary conditions for the water distribution system at the location of the proposed water service. Please refer to the attached figure indicating the request location. The proposed water service will connect to a new 203mm diameter Albert St watermain that will be installed as part of the City's Albert-Slater project.

The following domestic water demands have been calculated as per Table 4.2 of the City Water Design Guidelines (including Technical Bulletin ISD-2010-02).

| | | |
|-----------------------|---------|-------|
| Average Daily Demand | 16800.0 | L/day |
| Maximum Daily Demand | 25200.0 | L/day |
| Maximum Hourly Demand | 45360.0 | L/day |

The required fire flow (RFF) has been calculated in accordance with the Fire Underwriter Survey methodology, as per City Water Design Guidelines (including Technical Bulletin ISTB-2018-02).

| | | |
|--|-------|-------|
| Required Fire Flow (rounded to nearest 1000 L/min) | 14000 | L/min |
| | 233 | L/s |

Based on a preliminary review, three (3) AA rated hydrants (blue) have been identified within $\leq 120\text{m}$ of the building. Could you please confirm the rating of these hydrants so that we can ensure conformance with the requirements of Technical Bulletin ISTB-2018-02. Also, it is anticipated that one new AA rated hydrant will be installed between Brickhill St and Commissioner St as part of the Albert-Slater project.

If you require any further information, please let us know.

Thanks and Regards,
Bryan

Bryan Kipp, P.Eng.
Municipal Engineer
BKipp@morrisonhershfield.com



,

This e-mail originates from the City of Ottawa e-mail system. Any distribution, use or copying of this e-mail or the information it contains by other than the intended recipient(s) is unauthorized. Thank you.

Le présent courriel a été expédié par le système de courriels de la Ville d'Ottawa. Toute distribution, utilisation ou reproduction du courriel ou des renseignements qui s'y trouvent par une personne autre que son destinataire prévu est interdite. Je vous remercie de votre collaboration.

,
,

This e-mail originates from the City of Ottawa e-mail system. Any distribution, use or copying of this e-mail or the information it contains by other than the intended recipient(s) is unauthorized. Thank you.

Le présent courriel a été expédié par le système de courriels de la Ville d'Ottawa. Toute distribution, utilisation ou reproduction du courriel ou des renseignements qui s'y trouvent par une personne autre que son destinataire prévu est interdite. Je vous remercie de votre collaboration.

,
,

This e-mail originates from the City of Ottawa e-mail system. Any distribution, use or copying of this e-mail or the information it contains by other than the intended recipient(s) is unauthorized. Thank you.

Le présent courriel a été expédié par le système de courriels de la Ville d'Ottawa. Toute distribution, utilisation ou reproduction du courriel ou des renseignements qui s'y trouvent par une personne autre que son destinataire prévu est interdite. Je vous remercie de votre collaboration.

,

City of Ottawa - Water Distribution System Facilities & Feeder mains

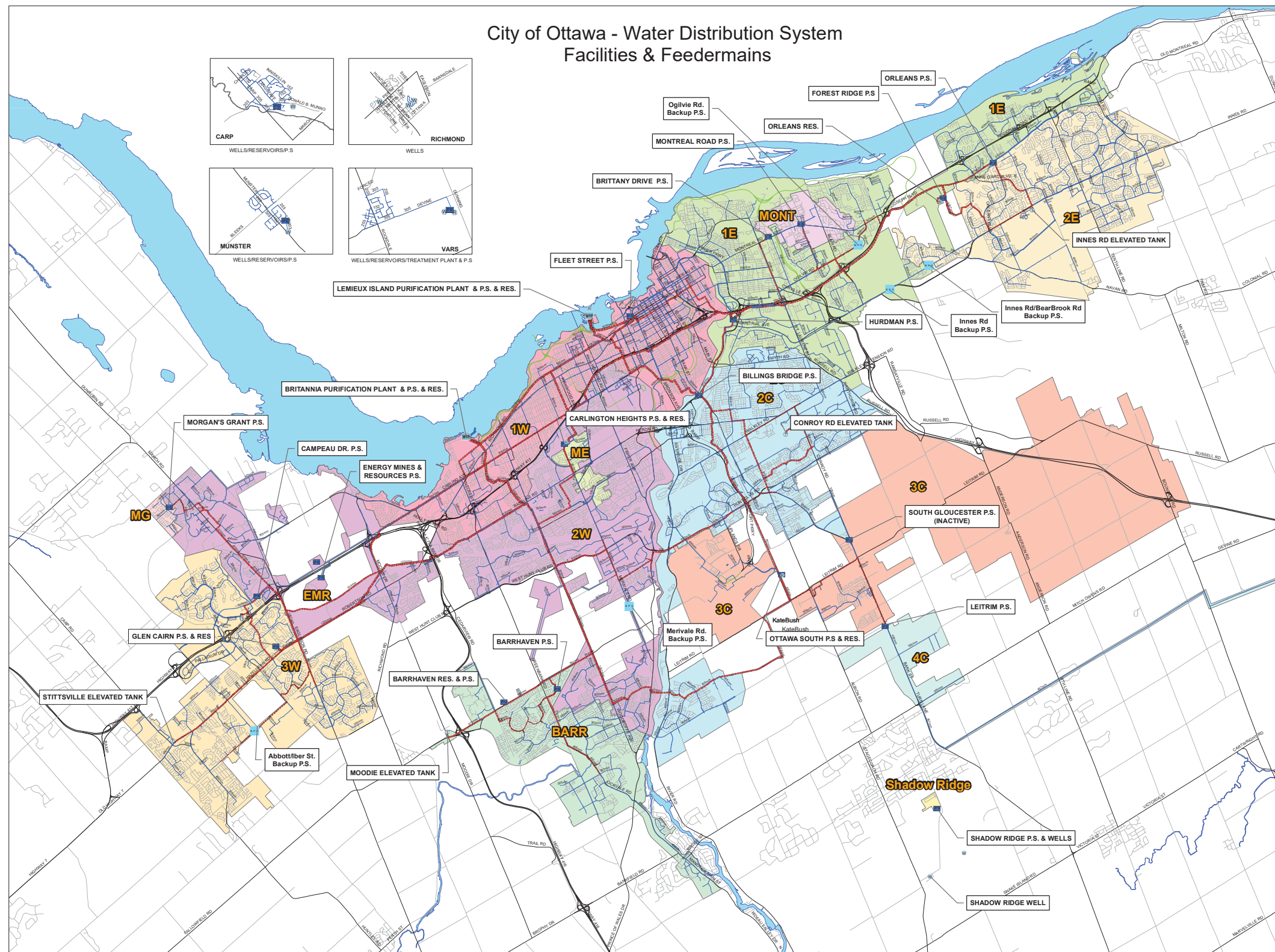

Legend

Water System Structure

- Pump Station
- Backup Pump Station
- Water Treatment Plant
- Well
- Elevated Tank
- Reservoir

WATERMAINS

Priority, Internal Diameter

- Backbone 1524mm - 1981mm
- Backbone 1067mm - 1372mm
- Backbone 610mm - 914mm
- Backbone 152mm - 305mm
- Backbone 152mm - 305mm
- Distribution 1676mm - 1981mm
- Distribution 1067mm - 1372mm
- Distribution 610mm - 914mm
- Distribution 406mm - 508mm
- Distribution 305mm - 381mm

PRESSURE ZONES

- 1E
- 1W
- 2C
- 2E
- 2W
- 3C
- 3W
- 4C
- BARR
- EMR
- ME
- MG
- MONT
- SHAD

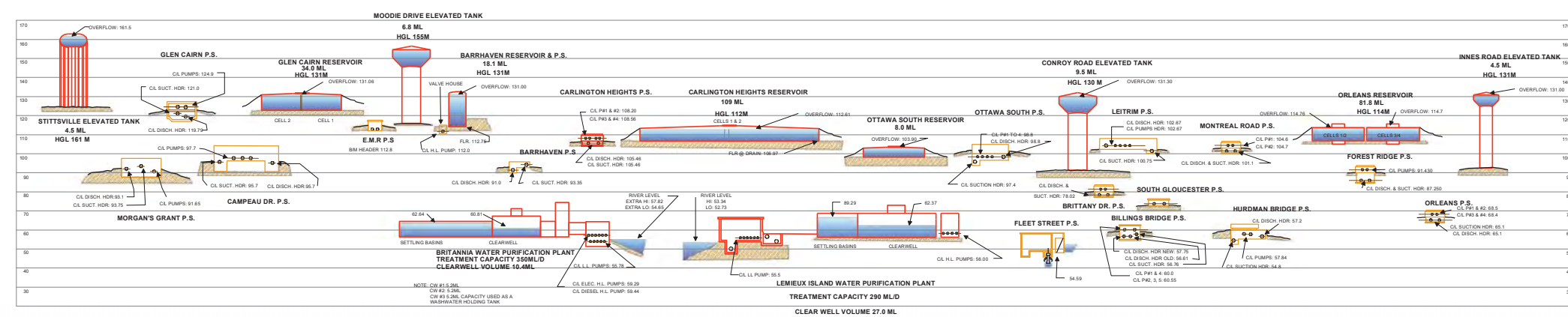

Infrastructure Services & Community Sustainability
Infrastructure Services

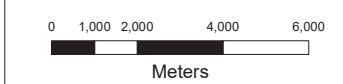

FIGURE 1-1
DRAWN BY: D. HESS DATE: 31 July 2013

Appendix C

Sanitary Flow Calculations

1. Sanitary Flow Estimate

OPL-LAC Joint Facility

Occupancy Based Calculation

| | | | |
|------------------------|------|-------------------|---|
| Occupancy | TBD | persons | Building occupancy to be determined by Architect (Sewer Design Guidelines, Appendix 4-A.3) |
| Per Capita Flow | 400 | l/c.d | |
| Daily average flow | | l/d | (Sewer Design Guidelines, Figure 4.3) |
| | | m ³ /d | |
| Peak Factor | 1.5 | | |
| Peak Flow | | l/s | |
| | | | |
| Site Area | | ha | |
| Infiltration allowance | 0.28 | l/s.gross ha | |
| Infiltration flow | 0 | l/s | |
| Peak Flow | 0.00 | l/s | |

Building Use Peak Flow

| | | |
|-------------------------|--------|------------------------|
| Gross Area | 0.97 | ha |
| Commercial Average Flow | 28 000 | l/ha/d |
| Peaking Factor | 1.5 | |
| Peak Extraneous Flows | 0.28 | L/s/effective gross ha |
| Peak Flow | 27 160 | L/day |
| | 0.31 | L/sec |

Peak flow occurs based on the building use based estimate, so a peak sanitary flow of 0.31 L/sec will be used for design.

| | | | |
|--------------------------------|------------------------------|--|---------------|
| Designed: N. Chauvin | | Project: OPL-LAC Joint Facility Proposed Servicing | |
| Checked: B. Kipp | Date: June 5, 2020 | Location: 555 Albert Street | |
| Dwg Reference: | File Ref: 19016770 | Sheet No.: | 1 of 1 |

2. Proposed Sanitary Sewer Design Sheet

OPL-LAC Joint Facility

| Location | | | Maintenance Hole Elevations | | | | | | Pipe | | | | | Notes | | |
|---|-----------------|--------|-----------------------------|--------------------------|---------------------|----------------------------|-----------------------|---------|--------------------------------|---------------|---------------|--|-----------------------|------------------------------|--|-----------------------------|
| Building | From | To | Invert (upstream) | Invert source (upstream) | Invert (downstream) | Invert source (downstream) | Drop in downstream MH | Reason | Length (m) | Length source | Diameter (mm) | Slope (%) | Capacity (Full) (L/s) | Velocity (Full) (m/s) | | |
| Proposed Sanitary Sewers | | | | | | | | | | | | | | | | |
| Proposed Private Sanitary Sewer | Building | MHSA01 | 59.86 | Design | 58.76 | Design | 0.03 | 45 Bend | 55.3 | Design | 250 | 2.00% | 84 | 1.71 | | |
| | MHSA01 | EX. MH | 58.73 | Design | 58.54 | Design | | | 9.3 | Design | 250 | 2.00% | 84 | 1.71 | | |
| | | | | | | | | | | | | | | | | |
| | | | | | | | | | | | | | | | | |
| | | | | | | | | | | | | | | | | |
| | | | | | | | | | | | | | | | | |
| Design Parameters | | | | | | | | | Designed: N. Chauvin | | | Project: OPL-LAC Joint Facility Proposed Servicing | | | | |
| Note 1: Proposed maintenance holes are shown in bold . | | | | | | | | | Checked: B. Kipp | | | Location: 555 Albert Street | | | | |
| Manning Roughness Coefficient, n = 0.013 | | | | | | | | | Dwg Reference: | | | File Ref: 19016770 | | Date: June 5, 2020 | | Sheet No.: 1 of 1 |

Appendix D

Storm Sewer Design Calculations

1. Existing Conditions & Release Rate

OPL-LAC Joint Facility

| | |
|--------------|-----------|
| Project No. | 190167700 |
| Date | 5-Jun-20 |
| Prepared By: | N Chauvin |
| Checked By | B Kipp |

Existing Drainage Area Characteristics

| Drainage Area | Area, A (ha) | Runoff Coefficient, R |
|---------------|--------------|-----------------------|
| A1 | 0.97 | 0.65 |
| Total | 0.97 | 0.65 |

Existing ground surface is a mix of gravel and hard surfaces

| | |
|----------------|----------|
| Asphalt Area: | R = 0.90 |
| Grassy Area: | R = 0.30 |
| Building Area: | R = 0.90 |
| Gravel Area: | R = 0.50 |
| Concrete Area: | R = 0.90 |

Existing Conditions

Q = RAIN where Q = runoff rate (L/s)
 R = runoff coefficient
 i = rainfall intensity (mm/hr)
 A = drainage area (ha)
 N = 2.78

and
$$i = \frac{A}{(T_d + C)^B}$$

Determination of Time of Concentration, using Inlet Time Graph (City of Ottawa Sewer Design Guidelines, Appendix 5D):

Existing drainage area with longest flow path = A1
 Approx. length of longest flow path (remote point to point of entry) = 60 m
 Surface type = Bare Earth (Gravel)
 Approximate surface slope = <2%

RELATIONSHIP BETWEEN DISTANCE OF REMOTE POINT IN TRIBUTARY AREA TO POINT OF ENTRY TO SEWER AND TIME TAKEN FOR PARTICLE OF WATER TO TRAVEL THIS DISTANCE FOR VARIOUS SURFACE SLOPES AND IMPERVIOUSNESS

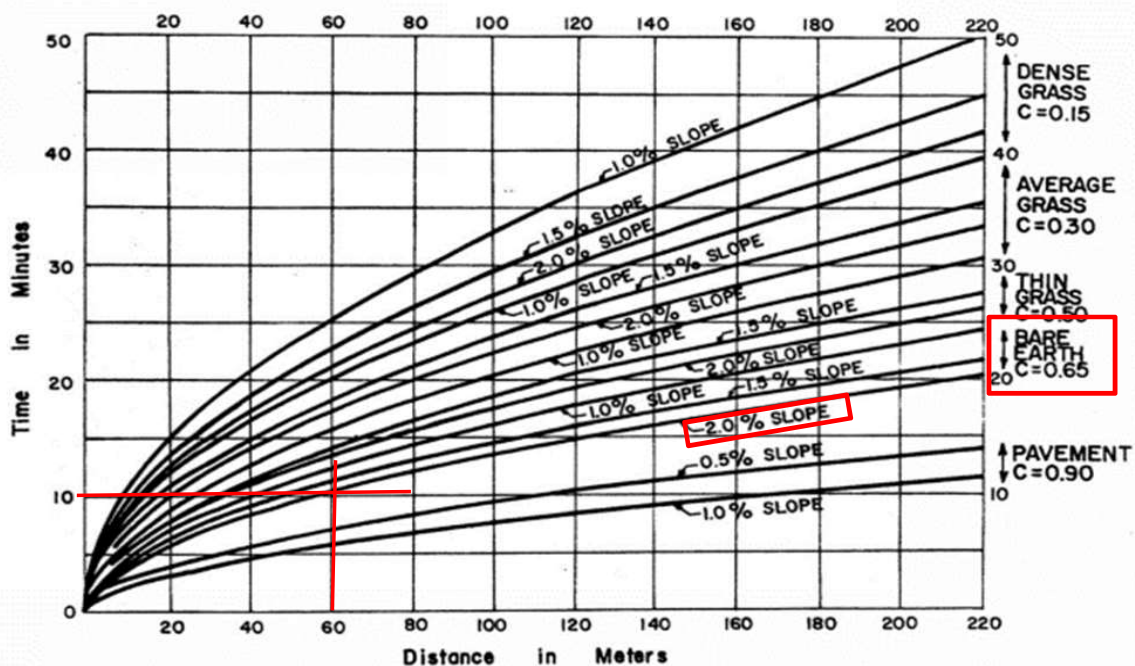

T_d = Time of Concentration = 10 (min)

| Return Period (Years) | A | B | C | Intensity, I (mm/hr) | Area (ha) | Runoff Coefficient, R (Note 1) | Runoff Rate, Q (L/s) |
|-----------------------|----------|-------|-------|----------------------|-----------|--------------------------------|----------------------|
| 2 | 732.951 | 0.81 | 6.199 | 76.8 | 0.970 | 0.65 | 134.6 |
| 5 | 998.071 | 0.814 | 6.053 | 104.2 | 0.970 | 0.65 | 182.6 |
| 100 | 1735.688 | 0.82 | 6.014 | 178.6 | 0.970 | 0.81 | 391.2 |

Note 1: For 100-year event, Runoff Coefficient is increased by 25% to a maximum of 1.0.

Allowable Release Rate

Criteria for calculation of allowable release rate:

| | |
|----------------------------|--|
| Return Period | 5 year (to suit capacity of downstream sewers) |
| Maximum Runoff Coefficient | 0.5 |
| Time of Concentration | 10 minutes |

| Return Period (Years) | A | B | C | Intensity, I (mm/hr) | Area (ha) | Runoff Coefficient, R | Runoff Rate, Q (L/s) |
|-----------------------|---------|-------|-------|----------------------|-----------|-----------------------|----------------------|
| 5 | 998.071 | 0.814 | 6.053 | 104.2 | 0.970 | 0.50 | 140.5 |

Allowable release rate from site in 100-year storm is 140.5 L/s

2. Proposed Uncontrolled Flow

OPL-LAC Joint Facility

| | |
|--------------|-----------|
| Project No. | 190167700 |
| Date | 5-Jun-20 |
| Prepared By: | N Chauvin |
| Checked By | B Kipp |

Summary of All Proposed Drainage Areas

| Drainage Area | Total Area, A (ha) | Impervious Area (ha) | Pervious Area (ha) | Runoff Coefficient, R (5-year event) | Runoff Coefficient, R (100-year event, Note 2) |
|----------------|--------------------|----------------------|--------------------|--------------------------------------|--|
| BLDG, Note 1 | 0.550 | 0.330 | 0.220 | 0.74 | 0.93 |
| A1 | 0.134 | 0.084 | 0.050 | 0.68 | 0.85 |
| A2 | 0.072 | 0.061 | 0.011 | 0.81 | 1.00 |
| A3 | 0.067 | 0.014 | 0.053 | 0.43 | 0.53 |
| B1 | 0.066 | 0.057 | 0.008 | 0.82 | 1.00 |
| B2 | 0.070 | 0.040 | 0.030 | 0.64 | 0.80 |
| B3 | 0.031 | 0.031 | | 0.90 | 1.00 |
| Total (Note 2) | 0.990 | | | 0.72 | 0.89 |

(Refer to Proposed Storm Drainage Area Plan)

Note 1: Building area includes approximately 0.25 ha of green roof (see below)

Note 2: Increase in total area is a result of building overhangs along Albert St.

Proposed Uncontrolled Drainage Area Characteristics

| Drainage Area | Area, A (ha) | Runoff Coefficient, R (5-year event) | Runoff Coefficient, R (100-year event, Note 1) |
|---------------|--------------|--------------------------------------|--|
| B1 | 0.066 | 0.82 | 1.00 |
| B2 | 0.070 | 0.64 | 0.80 |
| B3 | 0.031 | 0.90 | 1.00 |
| Total | 0.167 | 0.76 | 0.92 |

(Refer to Proposed Storm Drainage Area Plan)

Note 2: For 100-year event, Runoff Coefficient is increased by 25% to a maximum of 1.0.

Runoff coefficients used in calculations:

| | |
|-----------------------------|----------|
| Asphalt Area: | R = 0.90 |
| Grassy Area: | R = 0.30 |
| Building Area: | R = 0.90 |
| Gravel Area: | R = 0.50 |
| Green Roof ^[1] : | R = 0.50 |
| Concrete Area: | R = 0.90 |

^[1] Green Roofs: LID SWM Planning and Design Guide. (2017, June 27). Sustainable Technologies Evaluation Program.

Proposed Uncontrolled Runoff

Q = RAIN where Q = runoff rate (L/s)

R = runoff coefficient
i = rainfall intensity (mm/hr)
A = drainage area (ha)
N = 2.78

and
$$i = \frac{A}{(T_d + C)^B}$$

T_d = Time of Concentration = 10 (min)

| Return Period (Years) | A | B | C | Intensity, I (mm/hr) | Area (ha) | Runoff Coefficient, R | Runoff Rate, Q (L/s) |
|-----------------------|----------|-------|-------|----------------------|-----------|-----------------------|----------------------|
| 5 | 998.071 | 0.814 | 6.053 | 104.2 | 0.167 | 0.76 | 36.9 |
| 100 | 1735.688 | 0.82 | 6.014 | 178.6 | 0.167 | 0.92 | 76.3 |

Remaining Allowable Release Rate

Total Allowable Release Rate 140.5 (L/s)

Uncontrolled Runoff (100 year) 76.3 (L/s)

Remaining Allowable Release Rate 64.2 (L/s)

Runoff from remaining drainage areas in 100-year event will be controlled to 64.2 L/s

3. Proposed Storage

OPL-LAC Joint Facility

| | |
|--------------|-----------|
| Project No. | 190444600 |
| Date | 5-Jun-20 |
| Prepared By: | N Chauvin |
| Checked By | B Kipp |

Proposed Controlled Drainage Area Characteristics

| Drainage Area | Area, A (ha) | Runoff Coefficient, R (5-year event) | Runoff Coefficient, R (100-year event, Note 1) |
|---------------|--------------|--------------------------------------|--|
| BLDG | 0.550 | 0.74 | 0.93 |
| A1 | 0.134 | 0.68 | 0.85 |
| A2 | 0.072 | 0.81 | 1.00 |
| A3 | 0.067 | 0.43 | 0.53 |
| Total | 0.823 | 0.71 | 0.89 |

(Refer to Proposed Storm Drainage Area Plan)

Note 1: For 100-year event, Runoff Coefficient is increased by 25% to a maximum of 1.0.

$$\text{Allowable Release Rate from storage (100-year event)} = \begin{matrix} 64.2 \text{ (L/s)} \\ 231.06 \text{ (m}^3\text{/h)} \end{matrix}$$

Note 2: Release rate is constant as storm water pumping station to meet allowable release rate

Required Storage Volume (using Modified Rational Method)

$$Q = \text{RAIN}$$

$$Q = \text{runoff rate (L/s)} \quad i = \frac{A}{(T_d + C)^B} \quad \text{where } i = \text{Rainfall Intensity (mm/hr)}$$

$$R = \text{runoff coefficient} \quad T_d = \text{Time of Concentration (min)}$$

$$i = \text{rainfall intensity (mm/hr)}$$

$$A = \text{drainage area (ha)}$$

$$N = 2.78$$

| Time, Td (min) | 5-Year Event | | | | 100-Year Event | | | |
|----------------|-------------------|-----------------|----------------------------|----------------------------------|-------------------|-----------------|----------------------------|----------------------------------|
| | Intensity (mm/hr) | Peak Flow (L/s) | Average Release Rate (L/s) | Storage Volume (m ³) | Intensity (mm/hr) | Peak Flow (L/s) | Average Release Rate (L/s) | Storage Volume (m ³) |
| 5 | 141.18 | 229.3 | 64.18 | 49.5 | 242.70 | 394.2 | 64.18 | 99.0 |
| 10 | 104.19 | 169.2 | 64.18 | 63.0 | 178.56 | 290.0 | 64.18 | 135.5 |
| 15 | 83.56 | 135.7 | 64.18 | 64.4 | 142.89 | 232.1 | 64.18 | 151.1 |
| 20 | 70.25 | 114.1 | 64.18 | 59.9 | 119.95 | 194.8 | 64.18 | 156.8 |
| 25 | 60.90 | 98.9 | 64.18 | 52.1 | 103.85 | 168.7 | 64.18 | 156.7 |
| 30 | 53.93 | 87.6 | 64.18 | 42.1 | 91.87 | 149.2 | 64.18 | 153.1 |
| 40 | 44.18 | 71.8 | 64.18 | 18.2 | 75.15 | 122.1 | 64.18 | 138.9 |
| 50 | 37.65 | 61.2 | 64.18 | -9.1 | 63.95 | 103.9 | 64.18 | 119.1 |

minimum time = time of concentration

| | | | |
|---------------------|---------------------|---------------------|----------------------|
| Storage volume used | 64.4 m ³ | Storage volume used | 156.8 m ³ |
|---------------------|---------------------|---------------------|----------------------|

A storage tank with a minimum volume of 156.8 m³ is required.

4. Stormwater Pump Design

OPL-LAC Joint Facility

| | |
|--------------|-----------|
| Project No. | 190444600 |
| Date | 5-Jun-20 |
| Prepared By: | N Chauvin |
| Checked By | B Kipp |

Forcemain Configuration

Tank Inv 56.76 m
 Wet Well Inv 56.5 m
 Required Rated Capacity 0.064 m³/s

| Forcemain Data | | | | Friction Head | | | Fitting Losses | | | | | | | | | | Total Head Loss (m) | Static Head | | | Total Pump Head (m) | |
|--------------------------|--------------|------------|----------------|---------------|-----------------------|--------------------|-------------------|---------------|---------|---------|-----------------|----------------|----------|-------------|-----------|-------------------|---------------------|---------------------------|----------------------------|-----------------|---------------------|------|
| Flow (m ³ /s) | Diameter (m) | Length (m) | Velocity (m/s) | C | Head loss per m (m/m) | Total Friction (m) | Velocity Head (m) | Bends (close) | | | Tees sharp 1.20 | Valves | | Exit | | Total Fitting (m) | | Wet Well Elevation (mASL) | Discharge Elevation (mASL) | Static Head (m) | | |
| | | | | | | | | 22.5 0.15 | 45 0.30 | 90 0.75 | | open gate 0.12 | NRV 1.00 | sudden 1.00 | bell 0.20 | | | | | | | |
| 0.000 | 0.2 | 16.3 | 0.00 | 130 | 0.000 | 0.0 | 0.000 | 0 | 0 | 0 | 0 | 0 | 0 | 0 | 2 | 0 | 0.0 | 0.0 | 56.50 | 62.20 | 5.70 | 5.70 |
| 0.015 | 0.2 | 16.3 | 0.48 | 130 | 0.00139 | 0.0 | 0.012 | 0 | 0 | 0 | 0 | 0 | 0 | 0 | 2 | 0 | 0.0 | 0.0 | 56.50 | 62.20 | 5.70 | 5.75 |
| 0.030 | 0.2 | 16.3 | 0.95 | 130 | 0.005 | 0.1 | 0.046 | 0 | 0 | 0 | 0 | 0 | 0 | 0 | 2 | 0 | 0.1 | 0.2 | 56.50 | 62.20 | 5.70 | 5.87 |
| 0.045 | 0.2 | 16.3 | 1.43 | 130 | 0.011 | 0.2 | 0.105 | 0 | 0 | 0 | 0 | 0 | 0 | 0 | 2 | 0 | 0.2 | 0.4 | 56.50 | 62.20 | 5.70 | 6.08 |
| 0.064 | 0.2 | 16.3 | 2.04 | 130 | 0.020 | 0.3 | 0.212 | 0 | 0 | 0 | 0 | 0 | 0 | 0 | 2 | 0 | 0.4 | 0.8 | 56.50 | 62.20 | 5.70 | 6.46 |
| 0.073 | 0.2 | 16.3 | 2.32 | 130 | 0.026 | 0.4 | 0.275 | 0 | 0 | 0 | 0 | 0 | 0 | 0 | 2 | 0 | 0.6 | 1.0 | 56.50 | 62.20 | 5.70 | 6.67 |
| 0.088 | 0.2 | 16.3 | 2.80 | 130 | 0.037 | 0.6 | 0.400 | 0 | 0 | 0 | 0 | 0 | 0 | 0 | 2 | 0 | 0.8 | 1.4 | 56.50 | 62.20 | 5.70 | 7.10 |
| 0.103 | 0.2 | 16.3 | 3.28 | 130 | 0.049 | 0.8 | 0.548 | 0 | 0 | 0 | 0 | 0 | 0 | 0 | 2 | 0 | 1.1 | 1.9 | 56.50 | 62.20 | 5.70 | 7.60 |
| 0.118 | 0.2 | 16.3 | 3.76 | 130 | 0.063 | 1.0 | 0.719 | 0 | 0 | 0 | 0 | 0 | 0 | 0 | 2 | 0 | 1.4 | 2.5 | 56.50 | 62.20 | 5.70 | 8.17 |
| 0.133 | 0.2 | 16.3 | 4.23 | 130 | 0.079 | 1.3 | 0.913 | 0 | 0 | 0 | 0 | 0 | 0 | 0 | 2 | 0 | 1.8 | 3.1 | 56.50 | 62.20 | 5.70 | 8.81 |
| 0.148 | 0.2 | 16.3 | 4.71 | 130 | 0.096 | 1.6 | 1.131 | 0 | 0 | 0 | 0 | 0 | 0 | 0 | 2 | 0 | 2.3 | 3.8 | 56.50 | 62.20 | 5.70 | 9.53 |

Pump Configuration

Manufacturer Flygt
 Model N3153 LT3
 Speed 955 rpm
 Impellor 212 mm
 Motor Power 9 kW
 Rated Flow 0.065 m³/s
 Rated Head 6.67 m
 12 HP

| Head (m) | Flow (m ³ /s) | Flow from Two Pumps (m ³ /s) |
|----------|--------------------------|---|
| 14.10 | 0.00 | 0.00 |
| 10.70 | 0.02 | 0.04 |
| 9.20 | 0.04 | 0.08 |
| 7.10 | 0.06 | 0.12 |
| 4.50 | 0.08 | 0.16 |
| 1.90 | 0.10 | 0.20 |

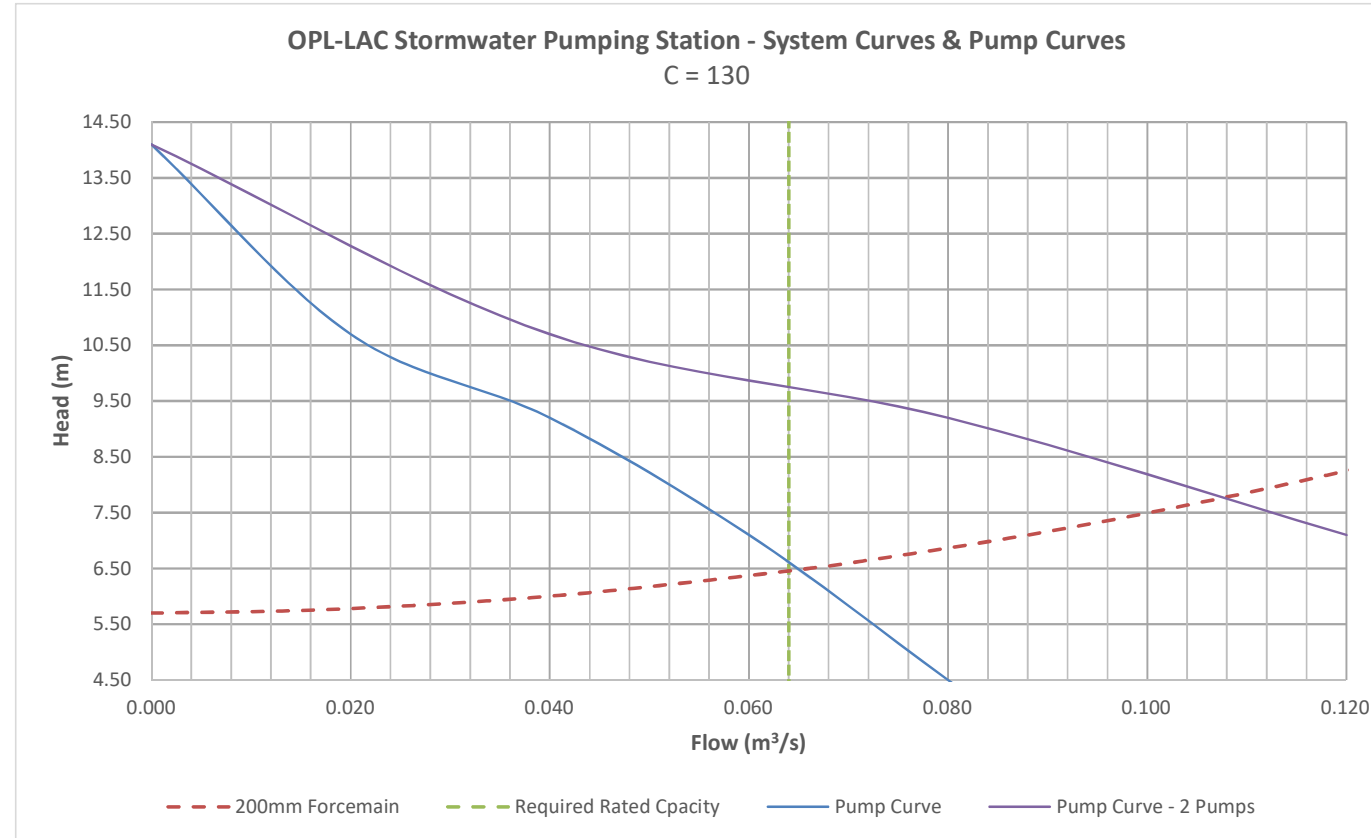

5. PROPOSED STORM SEWER CALCULATION SHEET

OPL-LAC Joint Facility

| LOCATION | | | | | INDIVIDUAL | | | | | | | CUMULATIVE | | DESIGN | | | | PROPOSED SEWER | | | | | | | | | | | | | |
|------------------------|--------|--------------|------------|--------------|--------------|------------|------------|-------------|------------|-------|-------|------------|-------|---------------|---------------------------|--------------------|-----------|----------------|--------|------|-------|-------|---------------|---------------|---------------|--------------|------------------|---------|-----------------|-------------------|--|
| Description | From | Top of Cover | To | Top of Cover | Asphalt Area | Lawn Areas | Bldg. Area | Gravel Area | Conc. Area | Total | R*A*N | Area | R*A*N | Time of Conc. | Storm Event Return Period | Rainfall Intensity | Peak Flow | | Length | Size | Area | Grade | Minimum Slope | Full Capacity | Full Velocity | Time of Flow | Reserve Capacity | Q/Qfull | Upstream Invert | Downstream Invert | Notes |
| | | (m) | | (m) | (ha) | (ha) | (ha) | (ha) | (ha) | (ha) | | (ha) | | (min.) | (year) | (mm/hr) | (L/s) | (m³/s) | (m) | (mm) | (m²) | (%) | (%) | (L/s) | (m/s) | (min) | (L/s) | (%) | (m) | (m) | |
| A1 | CB03 | | MHST01 | | 0.084 | 0.050 | | | | 0.134 | 0.252 | 0.134 | 0.252 | 10.00 | 100.00 | 178.56 | 44.9 | 0.045 | 9.9 | 250 | 0.049 | 2.020 | 0.43 | 84.5 | 1.72 | 0.10 | 39.6 | 0.5 | 59.82 | 59.62 | |
| | MHST01 | | TANK | | | | | | | | | 0.134 | 0.252 | 10.00 | 100.00 | 178.56 | 44.9 | 0.045 | 6.3 | 375 | 0.110 | 3.500 | 0.25 | 328.0 | 2.97 | 0.04 | 283.1 | 0.1 | 58.31 | 58.09 | |
| A2 | CB01 | | TANK | | 0.061 | 0.011 | | | | 0.072 | 0.161 | 0.072 | 0.161 | 10.00 | 100.00 | 178.56 | 28.8 | 0.029 | | | | | | | | | | | | | CB01 discharges directly into tank |
| A3 | CB02 | | TANK | | 0.014 | 0.053 | | | | 0.067 | 0.080 | 0.067 | 0.080 | 10.00 | 100.00 | 178.56 | 14.2 | 0.014 | 28.4 | 250 | 0.049 | 5.000 | 0.43 | 133.0 | 2.71 | 0.17 | 118.7 | 0.1 | 59.63 | 58.21 | |
| All Controlled Areas | TANK | | PS | | 0.489 | 0.334 | | | | 0.823 | 1.502 | 0.823 | 1.502 | 10.00 | 100.00 | 178.56 | 268.2 | 0.268 | 4.9 | 450 | 0.159 | 2.000 | 0.20 | 403.2 | 2.54 | 0.03 | 135.0 | 0.7 | 56.76 | 56.66 | |
| B1 | CB04 | | CBMH05 | | 0.057 | 0.008 | | | | 0.066 | 0.150 | 0.066 | 0.150 | 10.00 | 100.00 | 178.56 | 26.8 | 0.027 | 17.3 | 250 | 0.049 | 1.965 | 0.43 | 83.4 | 1.70 | 0.17 | 56.6 | 0.3 | 60.29 | 59.95 | |
| | CBMH05 | | Building | | | | | | | | | 0.066 | 0.150 | 10.17 | 100.00 | 177.02 | 26.6 | 0.027 | 4.8 | 250 | 0.049 | 2.083 | 0.43 | 85.8 | 1.75 | 0.05 | 59.3 | 0.3 | 59.92 | 59.82 | |
| All Catchments less B1 | MHST02 | | Connection | | 0.561 | 0.364 | | | | 0.925 | 1.706 | 0.925 | 1.706 | 10.00 | 5.00 | 104.19 | 204.4 | 0.204 | 10.8 | 375 | 0.110 | 2.000 | 0.25 | 248.0 | 2.25 | 0.08 | 43.6 | 0.8 | 62.12 | 61.90 | 100-year flow rate of B1 plus 5-year of remaining catchments |

Q = RAIN, where

Q = Peak flow (L/s)
R = Runoff coefficient
A = Area (ha)
I = Rainfall intensity (mm/hr)
N = 2.78

Asphalt Area: R = 0.90
Grassy Area: R = 0.30
Building Area: R = 0.90
Gravel Area: R = 0.50
Concrete Area: R = 0.90

Mannings Roughness Coefficient = 0.013

Prepared By: Noah Cauvin

Checked by: Bryan Kipp

Date: June 5, 2020

Project No. 190500700

6. Curb Inlet/Catch Basin 100-yr Ponding Depth

OPL-LAC Joint Facility

| | |
|--------------|-----------|
| Project No. | 190444600 |
| Date | 29-May-20 |
| Prepared By: | N Chauvin |
| Checked By | B Kipp |

Figure A

The highest 100-year flow to a single inlet flat grate catchbasin is at CB1 (28.8 L/s). The ponding depth under this flow rate is 75 mm.

The highest 100-year flow to a dual inlet catchbasin is at CB2 (14.2L/s). The ponding depth under this flow rate is 55 mm.

The highest 100-year flow to a dual inlet catchbasin is at CB3 (44.5L/s). The ponding depth under this flow rate is 90 mm.

Surface Inlet Capacity At Road Sags⁸

Design Charts

Design Chart 4.19: Inlet Capacity at Road Sag

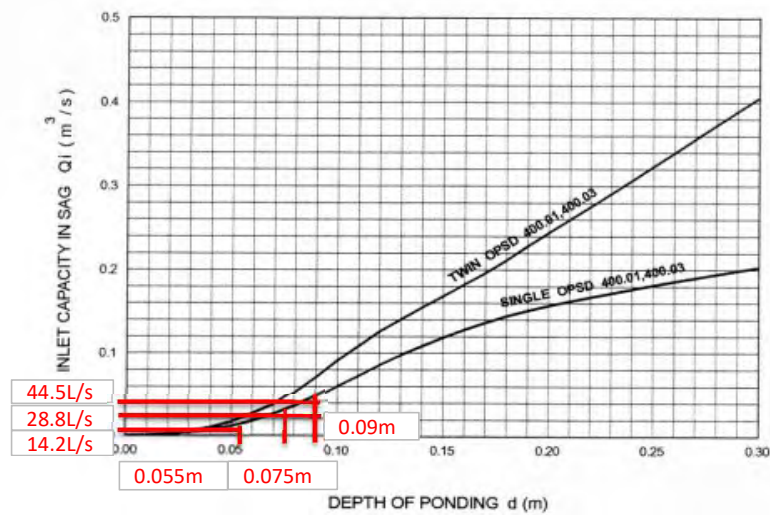

7. Commissioner St Hydraulic Analysis

OPL-LAC Joint Facility

| | |
|--------------|-----------|
| Project No. | 190167700 |
| Date | 29-May-20 |
| Prepared By: | N Chauvin |
| Checked By | B Kipp |

Commissioner St Catchment Area



Existing Drainage Area Characteristics

| Drainage Area | Area, A (ha) | Runoff Coefficient, R |
|---------------|--------------|-----------------------|
| A1 | 1.04 | 0.61 |
| Total | 1.04 | 0.61 |

| | |
|----------------|----------|
| Asphalt Area: | R = 0.90 |
| Grassy Area: | R = 0.30 |
| Building Area: | R = 0.90 |
| Gravel Area: | R = 0.50 |
| Concrete Area: | R = 0.90 |

Existing Conditions

Q = RAIN where Q = runoff rate (L/s)
 R = runoff coefficient
 i = rainfall intensity (mm/hr)
 A = drainage area (ha)
 N = 2.78

and
$$i = \frac{A}{(T_d + C)^B}$$

$$T_d = \text{Time of Concentration} = 10 \text{ (min)}$$

| Return Period (Years) | A | B | C | Intensity, I (mm/hr) | Area (ha) | Runoff Coefficient, R (Note 1) | Runoff Rate, Q (L/s) |
|-----------------------|----------|------|-------|----------------------|-----------|--------------------------------|----------------------|
| 2 | 732.951 | 0.81 | 6.199 | 76.8 | 1.040 | 0.61 | 135.8 |
| 100 | 1735.688 | 0.82 | 6.014 | 178.6 | 1.040 | 0.76 | 394.6 |

Peak Flow Rate

2-year Flow Rate 135.8 (L/s)
 100-year Runoff Rate 394.6 (L/s)
 Peak Flow Rate 258.8 (L/s)
Runoff from drainage area in 100-year event will be 258.8 L/s

Hydraulic Analysis Results

| Section | Return Period | Runoff Rate, Q (L/s) | Depth of Flow (m) |
|-------------|---------------|----------------------|-------------------|
| Section A-A | 100 | 258.8 | 0.07 |

Hydraulic analysis was modeled in Hydraulic Toolbox software, cross section was determined using existing and proposed grades along Commissioner St

Cross Section - 100 Year Event

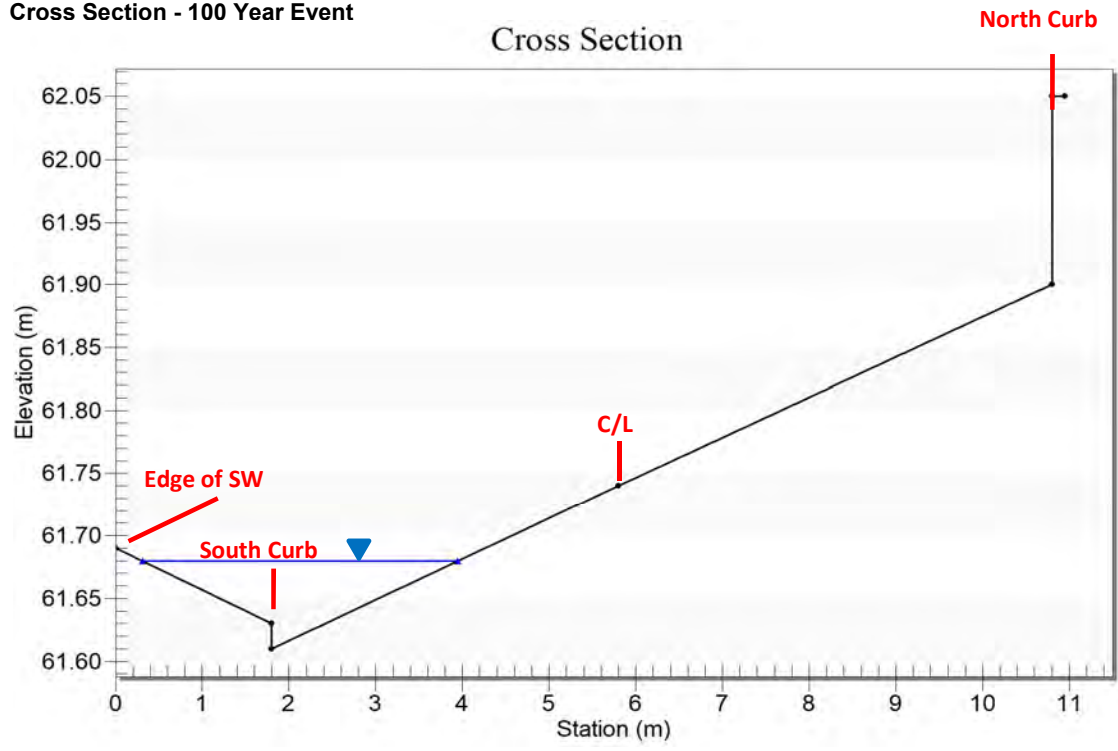

4.2 Green Roofs

4.2.1 Overview

Description

Green roofs, also known as “living roofs” or “rooftop gardens”, consist of a thin layer of vegetation and growing medium installed on top of a conventional flat or sloped roof (Figure 4.2.1). Green roofs are touted for their benefits to cities, as they improve energy efficiency, reduce urban heat island effects, and create greenspace for passive recreation or aesthetic enjoyment. To a water resources manager, they are attractive for their water quality, water balance, and peak flow control benefits. From a hydrologic perspective, the green roof acts like a lawn or meadow by storing rainwater in the growing medium and ponding areas. Excess rainfall enters underdrains and overflow points and is conveyed in the building drainage system. After the storm, a large portion of the stored water is evapotranspired by the plants, evaporates or slowly drains away.

There are two types of green roofs: intensive and extensive. Intensive green roofs contain greater than 15 centimetres depth of growing medium, can be planted with deeply rooted plants and are designed to handle pedestrian traffic. Roof structures supporting intensive green roofs require significantly greater load bearing capacity, thereby increasing their overall cost and complexity of design. Guidance in this guide focuses on extensive green roof design. Extensive green roofs consist of a thin layer of growing medium (15 centimetre depth or less) with a herbaceous vegetative cover. Two installation options are discussed: conventional and modular construction.

Figure 4.2.1 Examples of green roofs

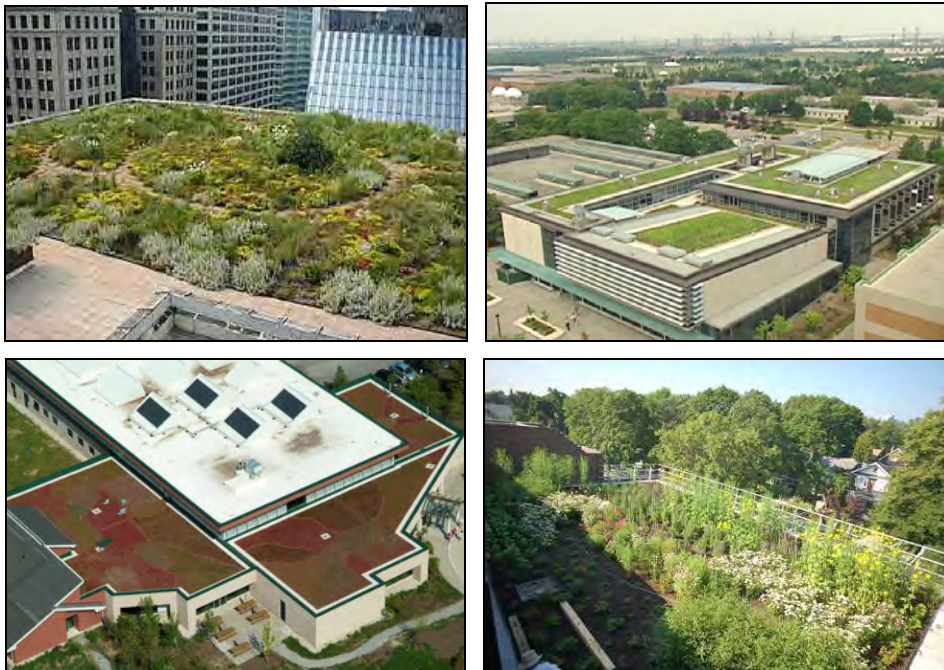

Clockwise from top left: Chicago City Hall (Source: Roofscapes, 2005); York University in Toronto, Jackman Public School in Toronto; and Earth Rangers Building in Vaughan (Source: TRCA)

Common Concerns

Green roofs have multiple benefits including improved aesthetics in urban areas, reduction of the urban heat island effect, improved air quality, and insulation of buildings. However, there are some common concerns that should be addressed through design:

- *Water Damage to Roof:* Ponding water on roofs with drain restrictions is a practice already in use in the Greater Toronto Area. While failure of waterproofing elements may present a risk of water damage, a warranty can ensure that any damage to the waterproofing system will be repaired, similar to traditional roof installations. Leak detection systems can also be installed to minimize or prevent water damage.
- *Vegetation Maintenance:* Extreme weather conditions can have an impact on plant survival. Appropriate plant selection will help to ensure plant survival during weather extremes (see Appendix B for guidance on plant selection). Irrigation during the first year may be necessary in order to establish vegetation. Vegetation maintenance costs decrease substantially after the first two years of operation, once plants become established.
- *Cost:* An analysis to determine cost effectiveness for a given site should include the roofing lifespan, energy savings, stormwater management requirements, aesthetics, market value, tax and other municipal incentives. It is estimated that green roofs can extend the life of a roof by as long as 20 years by reducing exposure of the roofing materials to sun and precipitation (Velazquez, 2005). They can also reduce energy demand by as much as 75% (TRCA, 2006). Some municipalities, such as the City of Toronto, offer green roof incentive programs that should be considered in the cost assessment. A study of the life cycle costs and savings of building and owning a green roof in the Greater Toronto Area was undertaken by TRCA (2007a).
- *Cold Climate:* Green roofs are a feasible BMP for cold climates (Figure 4.2.2). Snow can protect the vegetation layer and once thawed, will percolate into the growing medium and is either absorbed or drained away just as it would during a rain event. No seasonal adjustments in operation are needed.
- *On Private Property:* Property owners or managers will need to be educated on their routine operation and maintenance needs, understand the long-term maintenance plan, and may be subject to a legally binding maintenance agreement. An incentive program such as a storm sewer user fee based on the area of impervious cover on a property that is directly connected to a storm sewer (*i.e.*, does not first drain to a pervious area or LID practice) could be used to encourage property owners or managers to maintain existing practices.

Figure 4.2.2 A green roof during winter



Source: National Research Council Canada, 2006

Physical Suitability and Constraints

Green roofs are physically feasible in most development situations, but should be planned at the time of building design. Some key constraints are addressed below.

- *Structural Requirements:* Load bearing capacity of the building structure and selected roof deck need to be sufficient to support the weight of the soil, vegetation and accumulated water or snow, and may also need to support pedestrians, concrete pavers, etc. Standards for dead and live design loads are available from ASTM International. Although the Ontario Building Code (2006) does not specifically address the construction of green roofs, requirements from the *Building Code Act* and Division B may apply to components of the construction. Further requirements from sections 2.4 and 2.11 of the 1997 Ontario Fire Code also require consideration.
- *Roof Slope:* Green roofs may be installed on roofs with slopes up to 10%.
- *Drainage Area and Runoff Volume:* Green roofs are designed to capture precipitation falling directly onto the roof surface. They are not designed to receive runoff diverted from other source areas.

Typical Performance

The ability of green roofs to help meet stormwater management objectives is summarized in Table 4.2.1.

Table 4.2.1 Ability of green roofs to meet SWM objectives

| BMP | Water Balance Benefit | Water Quality Improvement | Stream Channel Erosion Control Benefit |
|-------------|-----------------------|---------------------------|--|
| Green Roofs | Yes | Yes | Yes |

Water Balance

Green roofs help achieve water balance objectives by reducing total annual runoff volumes. Considerable research has been conducted in recent years to define the runoff reduction capacity of extensive green roofs. Reported rates for runoff reduction have been shown to be a function of media depth, roof slope, annual rainfall and cold season effects. Based on the prevailing climate for the region, a conservative runoff reduction rate for green roofs of 45 to 55% is recommended for initial screening of LID practices. Results from select monitoring studies are provided in Table 4.2.2.

Table 4.2.2 Monitoring results – green roof runoff reduction

| Location | Monitoring Period | Substrate Depth (cm) | Runoff Reduction ¹ | Reference |
|--|---------------------------------------|----------------------|-------------------------------|---------------------------------|
| Toronto, Ontario | May '03 – Aug.'05 excluding winters | 14 | 63% ² | Van Seters <i>et al.</i> (2009) |
| Toronto, Ontario | Mar.'03 – Nov.'04 excluding winters | 7.5 and 10 | 57% ² | Liu and Minor (2005) |
| Ottawa, Ontario | Nov.'00 – Nov.'01 | 15 | 54% ² | Liu (2002) |
| East Lansing, Michigan | Apr.'05 – Nov.'05 & Apr.'06 – Sep.'06 | 6 | 75 to 85% | Getter <i>et al.</i> (2007) |
| East Lansing, Michigan | Aug.'02 – Oct.'03 excluding winter | 5.5 | 61% | VanWoert <i>et al.</i> (2005) |
| Portland, Oregon | May – Oct.'02 | 11 | 69% | Hutchinson <i>et al.</i> (2003) |
| Germany | Between 1987 and 2003 ³ | 10 ⁴ | 50% ⁵ | Mentens <i>et al.</i> (2005) |
| Kinston, North Carolina | July – Aug & Nov.- Dec.'03 | 10 | 64% | Hathaway <i>et al.</i> (2008) |
| Athens, Georgia | Nov.'03 – Nov.'04 | 11 | 78% | Carter and Rasmussen (2006) |
| Runoff Reduction Estimate⁶ | | 45 to 55% | | |

Notes:

1. Values represent total precipitation retained by the green roof over the monitoring period unless otherwise noted.
2. Value represents reduction in runoff from the green roof relative to a reference roof, not relative to precipitation.
3. Based on summary of 18 different studies examining 121 extensive green roofs.
4. Value represents the median substrate depth from 121 extensive green roofs.
5. Value represents the average runoff reduction as % of total annual precipitation, based on studies of 121 extensive green roofs.
6. This estimate is provided only for the purpose of initial screening of LID practices suitable for achieving stormwater management objectives and targets. Performance of individual facilities will vary depending on site specific contexts and facility design parameters and should be estimated as part of the design process and submitted with other documentation for review by the approval authority.

Water Quality – Pollutant Removal Capacity

Only a handful of monitoring studies have measured the pollutant removal performance of green roofs. A TRCA study comparing conventional black roof runoff to green roof runoff in Toronto was completed in 2006. The study conducted a water quality analysis for a total of 21 events during 2003 and 2004. Table 4.2.3 summarizes the water quality results. The loading ‘percent difference’ values shown in the right column represent the difference in loading, expressed as a percentage, between unit area loads from the conventional roof and the green roof. Designers should regard the pollutant load reductions shown below as an initial estimate until more performance monitoring becomes available.

Table 4.2.3 Comparative pollutant load reductions for a green roof

| Pollutant | Loading % Difference* (Conventional Roof vs. Green Roof) |
|--|---|
| Total Suspended Solids | 89 |
| Total Phosphorus | -248 |
| Nitrate | 91 |
| Aluminum | 69 |
| Zinc | 69 |
| Copper | 86 |
| <i>E. Coli</i> | 11 |
| *Positive values indicate lower pollutant loadings from the green roof. Negative values indicate higher pollutant loadings from the green roof. | |

Source: Van Seters et al, 2009

Other studies have also found higher concentrations of nutrients in green roof runoff that can be attributed to leaching from the growing medium (Hathaway *et al.*, 2008; Berndtsson *et al.*, 2006; Long *et al.*, 2007). Leaching may be reduced by using less organic matter and coated, controlled release fertilizer in the growing medium (Emilsson *et al.*, 2007). Further reductions in phosphorus may be achieved by filtering runoff through media that are specially engineered to bind phosphorus through sorption processes (Ma and Sansalone, 2007).

Stream Channel Erosion Control

The use of a green roof will reduce the channel erosion control driven detention requirement by decreasing the impervious cover area. If the total detention requirements can't be met by the green roof alone, flow restrictors on roof downspouts may also be used.

Other Benefits

The benefits of green roofs reach beyond the specific stormwater management goals to other social and environmental benefits, including:

- *Energy Conservation:* The layers of growing medium and vegetation on the roof moderate interior building temperatures and provide insulation from the heat and cold. As a result the amount of energy required to heat and cool the building is reduced, providing energy savings to the owner. To illustrate, a recent study by

Environment Canada and the National Research Council of Canada (NRC) planted a green roof with juniper shrubs growing in thick soil. The purpose of the design was to reduce the effect of wind speed (which draws heat from the building) and to increase the building's resistance to heat loss. Indoor temperature variations and energy consumption was compared with a traditional roof building. Measurements showed that heat flow from the building with the green roof was reduced by more than 10 percent (Bass, 2005). At the NRC Ottawa green roof, energy demand for air conditioning was reduced by 75% (Liu, 2002).

- *Acoustic Insulation:* Green roofs can also be designed to insulate the building interior from outside noise, and sound-absorbing properties of green roof infrastructure can make surrounding areas quieter.
- *Urban Heat Island Effect:* Green roofs can reduce the urban heat island effect by cooling and humidifying the surrounding air. Temperature of runoff from the roof will also be lower, which is a benefit to temperature-sensitive aquatic life.
- *Aesthetics and Habitat:* With thoughtful design, green roofs can be aesthetically pleasing and can improve views from neighboring buildings. Additionally, the rooftop vegetation creates habitat for birds and butterflies.
- *Reduced Demand on Downstream Infrastructure:* The reduction in runoff volumes associated with green roofs can lessen the demand on existing downstream stormwater infrastructure, and, in the case of combined sewers, lower the frequency of overflows.
- *Increased Longevity of Roof Structure:* The green roof mitigates extreme temperatures and exposure to storms and extends the longevity of the roof structure.

4.2.2 Design Template

Applications

Green roofs can be installed on many types of roofs (Figure 4.2.3), from small slanting residential roofs to large commercial roofs. Sometimes only a portion of the roof is dedicated to a green roof. This best management practice is particularly useful in ultra urban sites where space for surface BMPs is limited.

Figure 4.2.3 Other examples of green roofs



Source: City of Toronto (left); CWP (right)

Typical Details

Schematic renderings of typical green roofs are provided in Figures 4.2.4 and 4.2.5.

Figure 4.2.4 Schematic of a green roof

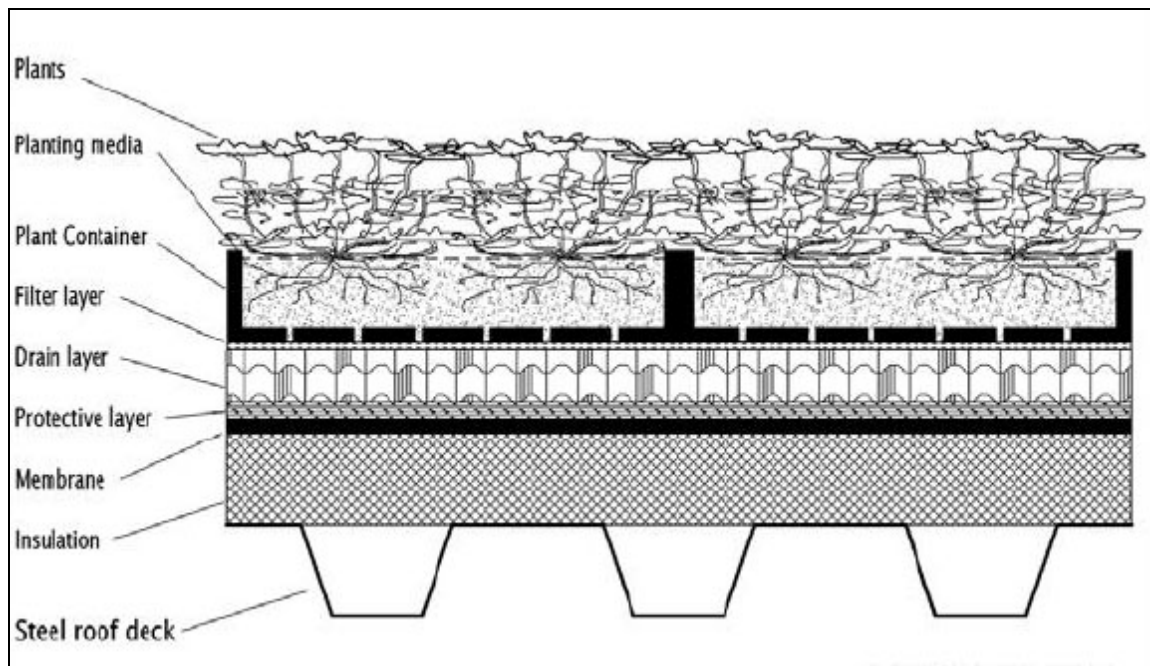

Source: Shade Consulting, 2003

Figure 4.2.5 Green roof layers



Source: Great Lake Water Institute

Design Guidance

Only qualified professionals should design green roofs (e.g., Green Roof Professional certification program, sponsored by Green Roofs For Healthy Cities; www.greenroofs.org).

Green roofs are composed of multiple layers that include:

- a roof structure capable of supporting the weight of a green roof system;
- a waterproofing membrane system designed to protect the building and roof structure;
- a drainage layer that consists of a porous medium capable of water storage for plant uptake;
- a filter layer to prevent fine particulate from the growing medium and roots from clogging the drainage layer;
- growing medium with appropriate characteristics to support selected green roof plants; and
- plants with appropriate tolerance for harsh roof conditions and shallow rooting depths.

Details on these layers are provided below.

Roof Structure

The load bearing capacity of the roof structure must be sufficient to support the soil and plants of the green roof assembly, as well as the live load associated with maintenance staff accessing the roof. Generally, a green roof assembly weighing more than 80 kilograms per square metre, when saturated, requires consultation with a structural engineer (Barr Engineering, 2003). Standards for dead and live design loads are available from ASTM International.

Green roofs may be installed on roofs with slopes up to 10%. On sloped roofs additional erosion control measures may be necessary to stabilize drainage layers.

As a fire resistance measure, non-vegetative materials, such as stone or pavers should be installed around all roof openings and at the base of all walls that contain openings (Barr Engineering, 2003). Materials used around roof openings should be non-leaching to prevent contamination of the green roof growing medium.

Waterproofing System

In a green roof system, the first layer above the roof surface is a waterproofing membrane. Two common waterproofing techniques used for the construction of green roofs are monolithic and thermoplastic sheet membranes. Another option is a liquid-applied inverted roofing membrane assembly system in which the insulation is placed over the waterproofing, which adheres to the roof structure. An additional protective layer is generally placed on top of the membrane followed by a physical or chemical root barrier. Once the waterproofing system has been installed it should be fully tested prior to construction of the drainage system. Electronic leak detection systems should also be installed at this time (The Folsom Group, 2004).

Drainage Layer

The drainage system includes a porous drainage layer and a geosynthetic filter mat to prevent fine growing medium particles from clogging the porous media. The drainage layer can be made up of gravels or recycled-polyethylene materials that are capable of water retention and efficient drainage. The depth of the drainage layer depends on the load bearing capacity of the roof structure and the stormwater retention requirements. The porosity of the drainage layer should be greater than or equal to 25% (PDEP, 2006).

Conveyance and Overflow

Once the porous media is saturated, all runoff (infiltrate or overland flow) should be directed to a traditional roof storm drain system. Landscaping style catch basins should be installed with the elevation raised to the desired ponding elevation. Alternately, roof drain flow restrictors can be used. Excess runoff can be directed through roof leaders to another stormwater BMP such as a rain barrel, soakaway, bioretention area, swale or simply drain to a pervious area (*i.e.*, downspout disconnection).

Growing Medium

The growing medium is usually a mixture of sand, gravel, crushed brick, compost, or organic matter combined with soil. The medium ranges between 40 and 150 millimetres

in depth and increases the roof load by 80 to 170 kilograms per square metre when fully saturated. The sensitivity of the receiving water to which the green roof ultimately drains should be taken into consideration when selecting the growing medium mix. Green roof growing media with less compost in the mix will have less leaching of nitrogen and phosphorus (Moran and Hunt, 2005). Low nutrient growing media also promotes the dominance of stress-tolerant native plants (TRCA, 2006). Fertilizer applied to the growing medium during production and the period during which vegetation is becoming established should be coated controlled release fertilizer to reduce the risk of damage to vegetation and leaching of nutrients into overflowing runoff. Application of fertilizer to the growing medium should not exceed a rate of 5 grams of nitrogen per square metre (Emilsson *et al.*, 2007).

Landscaping

A qualified botanist or landscape architect should be consulted when choosing plant material. For extensive systems, plant material should be confined to hardier or indigenous varieties of grass and sedum. Some sedums, however are invasive. The use of native plants is encouraged (see Appendix B for guidance regarding plant species selection). Root size and depth should also be considered to ensure that the plant will stabilize the shallow depth of growing medium. The plant material should conform to the following:

- *Type of root preparation, sizing, grading and quality:* should comply with the Canadian Standards for Nursery Stock, 2006 Edition, published by the Canadian Nursery Trades Association.
- *Source of plant material:* should be grown in Zone 4 in accordance with Agriculture Canada's Plant Hardiness Zone Map.
- *Plant material:* should be free of disease, insects, defects or injuries and structurally sound with strong fibrous root systems. Should have been root pruned regularly, but not later than one growing season prior to arrival on site.
- *Bare root stock:* should be nursery grown, in dormant stage, not balled and burlapped or container grown.
- *Seed mixes:* should be Common No.1 Canada certified in accordance with Government of Canada Seeds Act and Regulation.

Modular Systems

Modular systems are essentially trays of vegetation in a growing medium that are prepared and grown off-site and placed on the roof for complete coverage. There are also pre-cultivated vegetation blankets that are grown in a flexible growing medium structure, rather than a rigid structure, allowing them to be rolled out onto the underlying green roof assembly. The advantage of these systems is that they can be removed for maintenance.

Other Design Resources

Several other resources that provide useful design guidance for green roofs are:

Canada Mortgage and Housing Corporation: Design Guidelines for Green Roofs..<http://www.cmhc.ca/en/inpr/bude/himu/coedar/loader.cfm?url=/commonspot/security/getfile.cfm&PageID=70146>

2004 Portland Stormwater Management Manual.
<http://www.portlandonline.com/bes/index.cfm?c=dfbbh>

Philadelphia Stormwater Management Guidance Manual.
<http://www.phillyriverinfo.org/Programs/SubprogramMain.aspx?Id=StormwaterManual>

BMP Sizing

Green roofs reduce the effective impervious cover by providing a surface that hydrologically responds like a pervious area. Green roofs are typically sized based on the available roof area, as opposed to treatment volume requirements. However, flow restrictors can be added to the design to meet channel erosion control discharge criteria, which is determined by using the methodology in the relevant CVC and TRCA stormwater management criteria documents (CVC, 2010; TRCA, 2010).

Design Specifications

ASTM International released the following Green Roof standards in 2005:

- E2396-05 Standard Test Method for Saturated Water Permeability of Granular Drainage Media;
- E2397-05 Standard Determination of Dead Loads and Live Loads associated with Green Roof Systems;
- E2398-05 Standard test method for water capture and media retention of geocomposite drain layers for green roof systems;
- E2399-05 Standard Test Method for Maximum Media Density for Dead Load Analysis of Green Roof Systems; and
- E2400-06 Standard Guide for Selection, Installation, and Maintenance of Plants for Green Roof Systems.

Although the Ontario Building Code (2006) does not specifically address the construction of green roofs, requirements from the *Building Code Act* and Division B may apply to components of the construction. Further requirements from sections 2.4 and 2.11 of the 1997 *Ontario Fire Code* also require consideration.

Construction Considerations

An experienced professional green roof installer should install the green roof. The installer must work with the construction contractor to ensure that the waterproofing membrane installed is appropriate for use under a green roof assembly. Conventional green roof assemblies should be constructed in sections for easier inspection and

maintenance access to the membrane and roof drains. Green roofs can be purchased as complete systems from specialized suppliers who distribute all the assembly components, including the waterproofing membrane. Alternatively, a green roof designer can design a customized green roof and specify different suppliers for each component of the system.

4.2.3 Maintenance and Construction Costs

Maintenance

Green roof maintenance is typically greatest in the first two years as plants are becoming established. Vegetation should be monitored to ensure dense coverage becomes established. A warranty on the vegetation should be included in the construction contract.

Regular operation of a green roof includes:

- *Irrigation:* Watering should be based on actual soil moisture conditions as plants are designed to be drought tolerant. High soil moisture from unnecessary watering will reduce the runoff reduction benefits of the green roof.
- *Leak Detection:* Electronic leak detection is recommended. This system, also used with traditional roofs, must be installed prior to the green roof. Particular attention to leak detection should be paid in the first few months following installation (The Folsom Group, 2004).

Ongoing maintenance should occur at least twice per year (Magco, 2003) and should include:

- *Weeding:* Remove volunteer seedlings of trees and shrubs. Extensive green roofs are not designed for the weight of these plants, and the woody roots can damage the waterproofing.
- *Debris and Dead Vegetation Removal:* Debris and bird feces should be removed periodically. In particular, the overflow conveyance system should be kept clear (TRCA, 2006).

Installation and Operation Costs

The estimated cost for extensive green roofs is \$65 to \$230 CAD per square meter (TRCA, 2007a), not including the base roof, with modular systems in the lower end of the range. While green roofs are initially more expensive than traditional roofs, their lifecycle costs may be comparable to traditional roofs, when energy savings and extended roof longevity are factored in (TRCA, 2007a). Operation and maintenance costs are generally higher during the first two years of operation than in subsequent years as the vegetation becomes established. Literature estimates of annual maintenance costs during the first two years range from \$2.70 to \$44.00 per square metre (Peck and Kuhn, 2002; Stephens, *et al.*, 2002; TRCA, 2007a). Design costs

typically run 5 to 10 percent of the total project cost and administration and review and approval costs are 2.5 to 5 percent of the total project cost (Peck and Kuhn, 2002).

4.2.4 References

Barr Engineering Company. 2003. *Minnesota Urban Small Sites BMP Manual: Stormwater Best Management Practices for Cold Climates*. Metropolitan Council Environmental Services. St. Paul, MN.

<http://www.metrocouncil.org/environment/Watershed/bmp/manual.htm>

Bass, B. 2005. *Green Roofs in Winter: Hot Design for a Cold Climate*. University of Toronto. Centre for Environment. Adaptation & Impacts Research Group.

Carter, T.L. and Rasmussen, T.C. 2006. Hydrologic Behavior of Vegetated Roofs. *Journal of the American Water Resources Association*. October 2006.

City of Portland. 2004. *Portland Stormwater Management Manual*. Prepared by the Bureau of Environmental Services (BES). Portland, OR.

City of Toronto. *The Toronto Green Development Standard*. Toronto, ON.

City of Toronto. City of Toronto Green Roof Website.

<http://www.toronto.ca/greenroofs/index.htm>

Czemiel Berndtsson, J., Emilsson, T., Bengtsson, L. 2006. The influence of extensive vegetated roofs on runoff water quality. *Science of the Total Environment*. Vol. 355. pp. 48-63.

Emilsson, T., Czemiel Berndtsson, J., Mattson, J.E., Rolf, R. 2007. Effect of using conventional and controlled release fertilizer on nutrient runoff from various vegetated roof systems. *Ecological Engineering*. Vol. 29. pp. 260-271.

Getter, K., B. Rowe and J. Anderson. 2007. Quantifying the effect of slope on extensive green roof stormwater retention. *Ecological Engineering* 31: 225-231.

Great Lakes Water Institute. No Date. Green Roof Project. University of Wisconsin – Milwaukee. <http://www.glwi.uwm.edu/research/genomics/ecoli/greenroof/benefits.php>

Halsall Associates. City of Toronto Green “Vegetative” Roof Building Standard. June, 2007.

Hathaway, A.M., W.F. Hunt, G.D. Jennings. 2008. A field study of green roof hydrologic and water quality performance, *Transactions of the ASABE*, Vol. 51(1), pp. 1-8.

Hutchinson, D. P. Abrams, R. Retzlaff and T. Liptan. 2003. Stormwater monitoring of two ecoroofs in Portland, Oregon (USA). *Proceedings: Greening Rooftops for Sustainable Communities*: May 29-30, 2003; Chicago, Illinois.

Liptan, T. and E. Strecker. 2003. *Ecoroofs – A More Sustainable Infrastructure*. Presented at Urban Stormwater: Enhancing Programs at the Local Level. February 17-20, 2003. Cosponsored by US EPA, Chicago Botanic Gardens and Conservation Technology Information Center. Chicago, Illinois.

Liu, K. 2002. *Energy Efficiency and Environmental Benefits of Rooftop Gardens*. National Research Council Canada – Institute for Research in Construction. Ottawa, Ontario.

Liu, K. and J. Minor. 2005. *Performance Evaluation of an Extensive Greenroof*. National Research Council Canada – Institute for Research in Construction. Ottawa, Ontario.

Long, B., S. Clark, K. Baker, R. Berghage. 2007. *Selecting a Green Roof Media to Minimize Pollutant Loadings in Roof Runoff*. Presented at: 2nd National Low Impact Development Conference.

Ma J. and J. Sansalone 2007 Mass transfer behaviour of media for the treatment of stormwater phosphorus. *World Environmental and Water Resources congress*.

Magco, Inc.. *Intensive and Extensive Green Roofs*.
http://www.magco.com/extensive_intensive.html

Mentens, J. D. Raes and M. Herving. 2005. Green roof as a tool for solving rainwater runoff problems in the urbanized 21st century? *Landscape and Urban Planning* (3): 217-226

Moran, A. and B. Hunt. 2005. Green roof hydrologic and water quality performance in North Carolina. *2005 ASAE Annual International Meeting*. Tampa, FL. 17 July, 2005

National Research Council Canada. 2006. Green Roof Technology Adapted to Cold Climates. *EnviroZine Issue 62*.
http://www.ec.gc.ca/EnviroZine/english/issues/62/feature2_e.cfm

Peck, S.W. and M.E. Kuhn, 2002. *Design Guidelines for Green Roofs*. Report prepared for the Ontario Association of Architects and the Canada Mortgage and Housing Corporation, Toronto, Ontario.

Pennsylvania Department of Environmental Protection (PDEP). 2006. *Pennsylvania Stormwater Best Management Practices Manual*. Prepared by Cahill Associates Inc., Harrisburg, PA.

Philadelphia Water Department (PWD). 2007. *Philadelphia Stormwater Management Guidance Manual*. Philadelphia, PA.

Roofscapes, Inc. Accessed 2005. *Green Technology for the Urban Environment*. www.roofmeadow.com

Shade Consulting. 2003. www.shadeconsulting.com

Stephens, K. A., Graham, P. and D. Reid. 2002. *Stormwater Planning: A Guidebook for British Columbia*. British Columbia Ministry of Water, Land and Air Protection.

The Cardinal Group, Inc. 2002. www.greenroofs.ca.

The Folsom Group. 2004. *Feasibility study for: Vegetated Roof for Albemarle County Office Building*. Charlottesville, VA.

Toronto and Region Conservation Authority (TRCA). 2006. *Evaluation of an Extensive Greenroof York University*. Sustainable Technologies Evaluation Program. Toronto, Ontario.

Toronto and Region Conservation Authority (TRCA). 2007a. *An Economic Analysis of Green Roofs: Evaluating the costs and savings to business owners in Toronto and surrounding regions*. Sustainable Technologies Evaluation Program, Toronto, Ontario.

University of Waterloo School of Architecture. 2005. Case Studies in Canadian Sustainable Design. http://www.architecture.uwaterloo.ca/faculty_projects/terri/sustain_casestudies/mec_toronto.html

Van Seters, T., Rocha, L., Smith, D., MacMillan, G. 2009. Evaluation of Green Roofs for Runoff Retention, Runoff Quality and Leachability. *Water Quality Research Journal of Canada*. Vol. 44. No. 1. pp. 33 – 48.

VanWoert, N, D. Rowe, J. Anderson, C. Rugh, R. Fernandez and L. Xiao. 2005. Green roof stormwater retention: effects of roof surface, slope and media depth. *Journal of Environmental Quality*. 34(3): 1036-1044.

Velazquez, L. S. 2005. Greenroofs.com. <http://www.greenroofs.com>

NP 3127 LT 3~ Adaptive 424

Patented self cleaning semi-open channel impeller, ideal for pumping in waste water applications. Possible to be upgraded with Guide-pin® for even better clogging resistance. Modular based design with high adaptation grade.



Technical specification



Curves according to: Water, pure [100%], 4 °C, 999.9 kg/m³, 1.5692 mm²/s

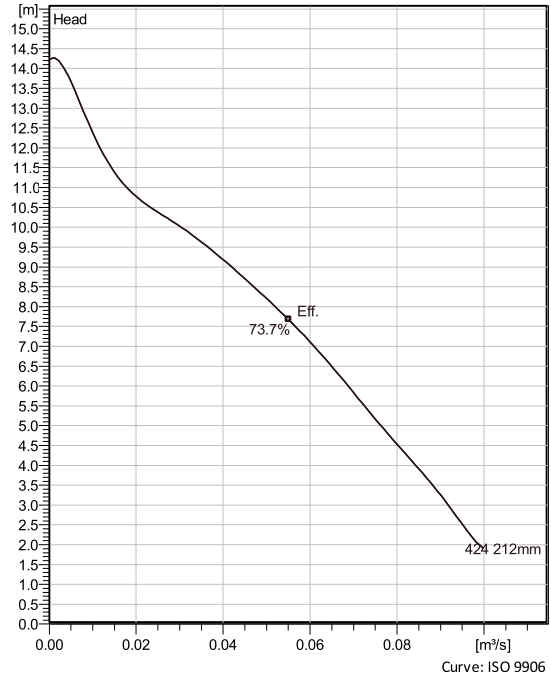

Configuration

| | |
|---|---|
| Motor number N3127.060 21-12-4AL-W 5.9KW | Installation type P - Semi permanent, Wet |
| Impeller diameter 212 mm | Discharge diameter 150 mm |

Pump information

| |
|--|
| Impeller diameter 212 mm |
| Discharge diameter 150 mm |
| Inlet diameter 150 mm |
| Maximum operating speed 1460 rpm |
| Number of blades 2 |
| Max. fluid temperature 40 °C |

Materials

| |
|--|
| Impeller Hard-Iron™ |
| Stator housing material Grey cast iron |

Project
Block

Created by
Created on 6/4/2020

Last update

NP 3127 LT 3~ Adaptive 424

Technical specification



Motor - General

| | | | |
|---|-------------------------------|--------------------------------|------------------------------|
| Motor number N3127.060 21-12-4AL-W 5.9KW | Phases 3~ | Rated speed 1460 rpm | Rated power 5.9 kW |
| ATEX approved No | Number of poles 4 | Rated current 27 A | Stator variant 28 |
| Frequency 50 Hz | Rated voltage 190 V | Insulation class H | Type of Duty S1 |
| Version code 060 | | | |

Motor - Technical

| | | | |
|--|--|--|-----------------------------------|
| Power factor - 1/1 Load 0.78 | Motor efficiency - 1/1 Load 86.4 % | Total moment of inertia 0.0623 kg m ² | Starts per hour max. 30 |
| Power factor - 3/4 Load 0.71 | Motor efficiency - 3/4 Load 86.9 % | Starting current, direct starting 172 A | |
| Power factor - 1/2 Load 0.59 | Motor efficiency - 1/2 Load 85.7 % | Starting current, star-delta 57.3 A | |

Project
Block

Created by
Created on 6/4/2020

Last update

NP 3127 LT 3~ Adaptive 424

Performance curve



Duty point

Flow
0.065 m³/s

Head
6.48 m

Curves according to: Water, pure [100%], 4 °C, 999.9 kg/m³, 1.5692 mm²/s

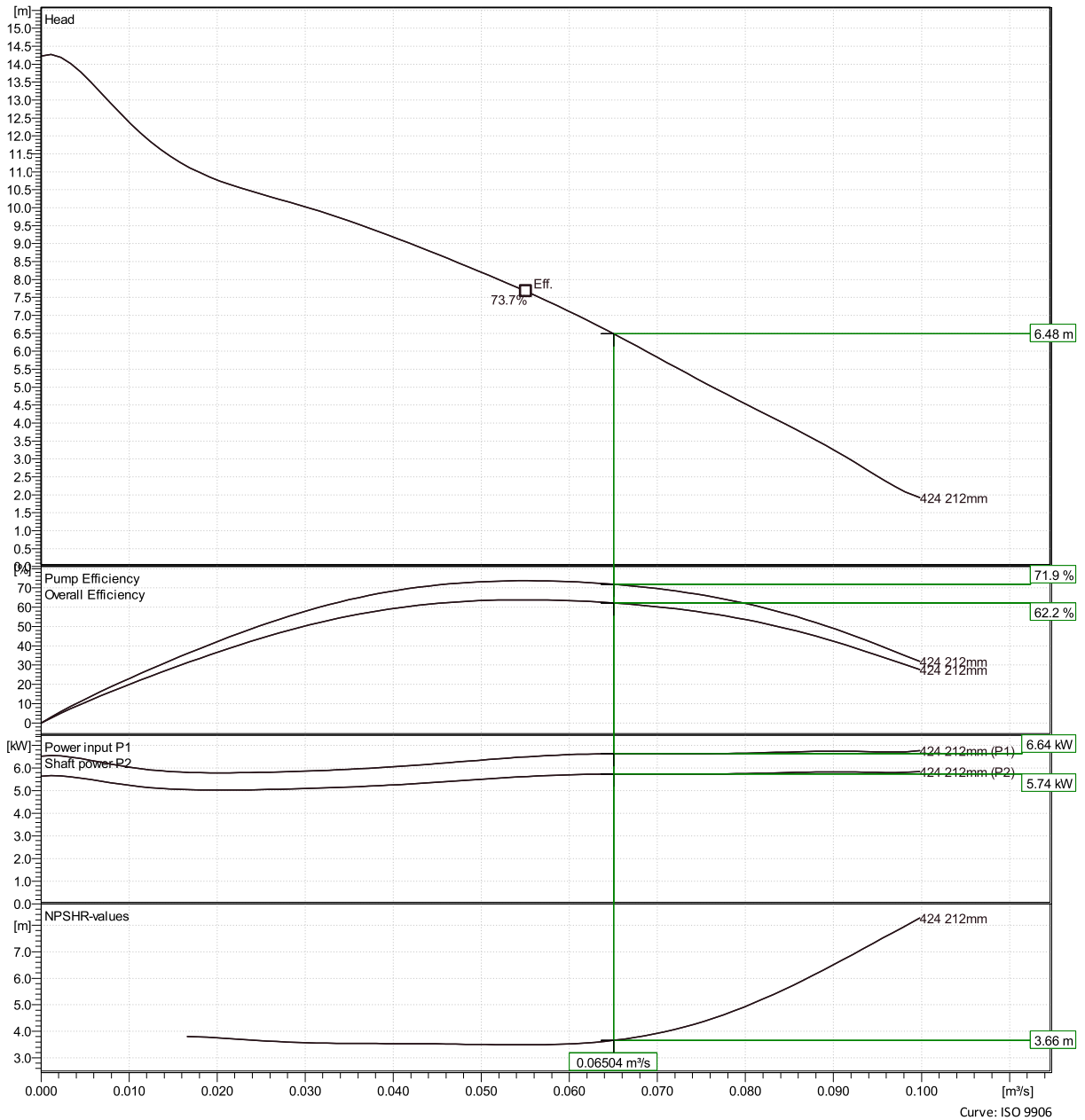

| | | |
|----------------|----------------------------|--------------------|
| Project | Created by | Last update |
| Block | Created on 6/4/2020 | |

Curve: ISO 9906

NP 3127 LT 3~ Adaptive 424

Duty Analysis



Curves according to: Water, pure [100%]; 4°C; 999.9kg/m³; 1.5692mm²/s

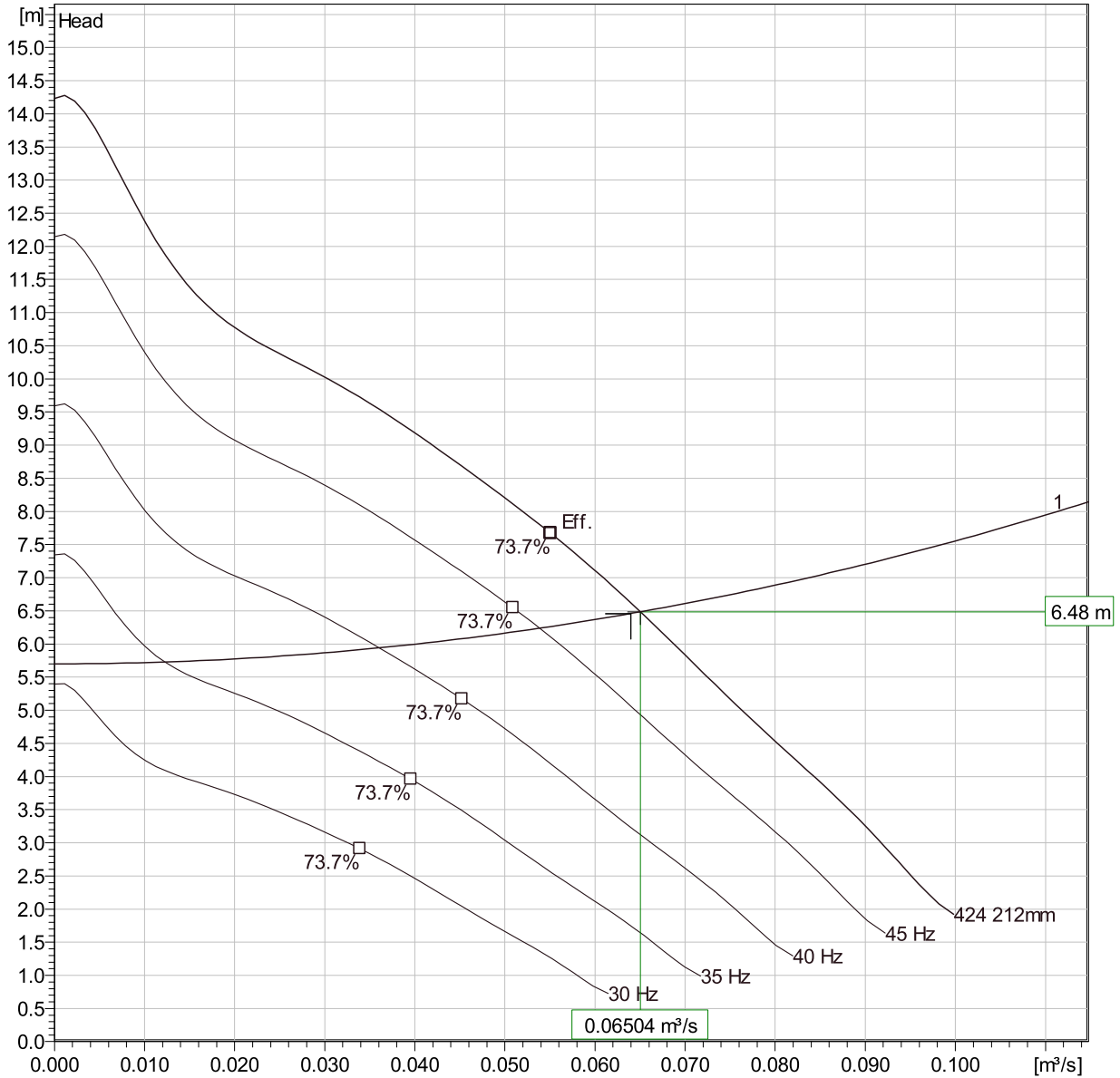

Operating characteristics

| Pumps / Systems | Flow | Head | Shaft power | Flow | Head | Shaft power | Hydr.eff. | Specific Energy | NPSHre |
|-----------------|------------|--------|-------------|------------|--------|-------------|-----------|-----------------|--------|
| 1 | 0.065 m³/s | 6.48 m | 5.74 kW | 0.065 m³/s | 6.48 m | 5.74 kW | 71.9 % | 0.0283 kWh/m³ | 3.66 m |

Project
Block

Created by
Created on 6/4/2020

Last update

NP 3127 LT 3~ Adaptive 424

VFD Curve



Curves according to: Water, pure [100%], 4 °C, 999.9 kg/m³, 1.5692 mm²/s

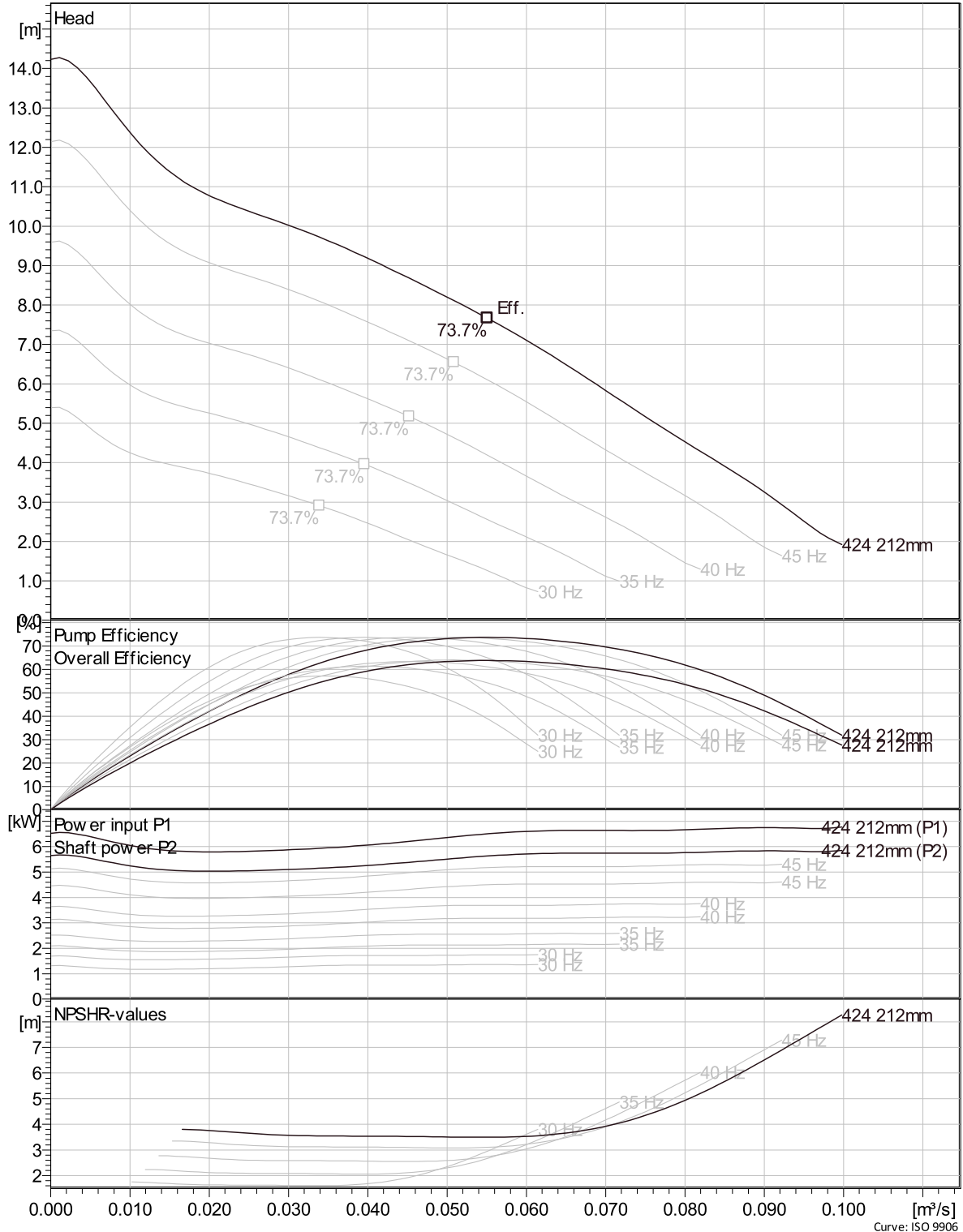

| Project | Created by | Last update |
|---------|---------------------|-------------|
| Block | Created on 6/4/2020 | |

Curve: ISO 9906

NP 3127 LT 3~ Adaptive 424

VFD Analysis

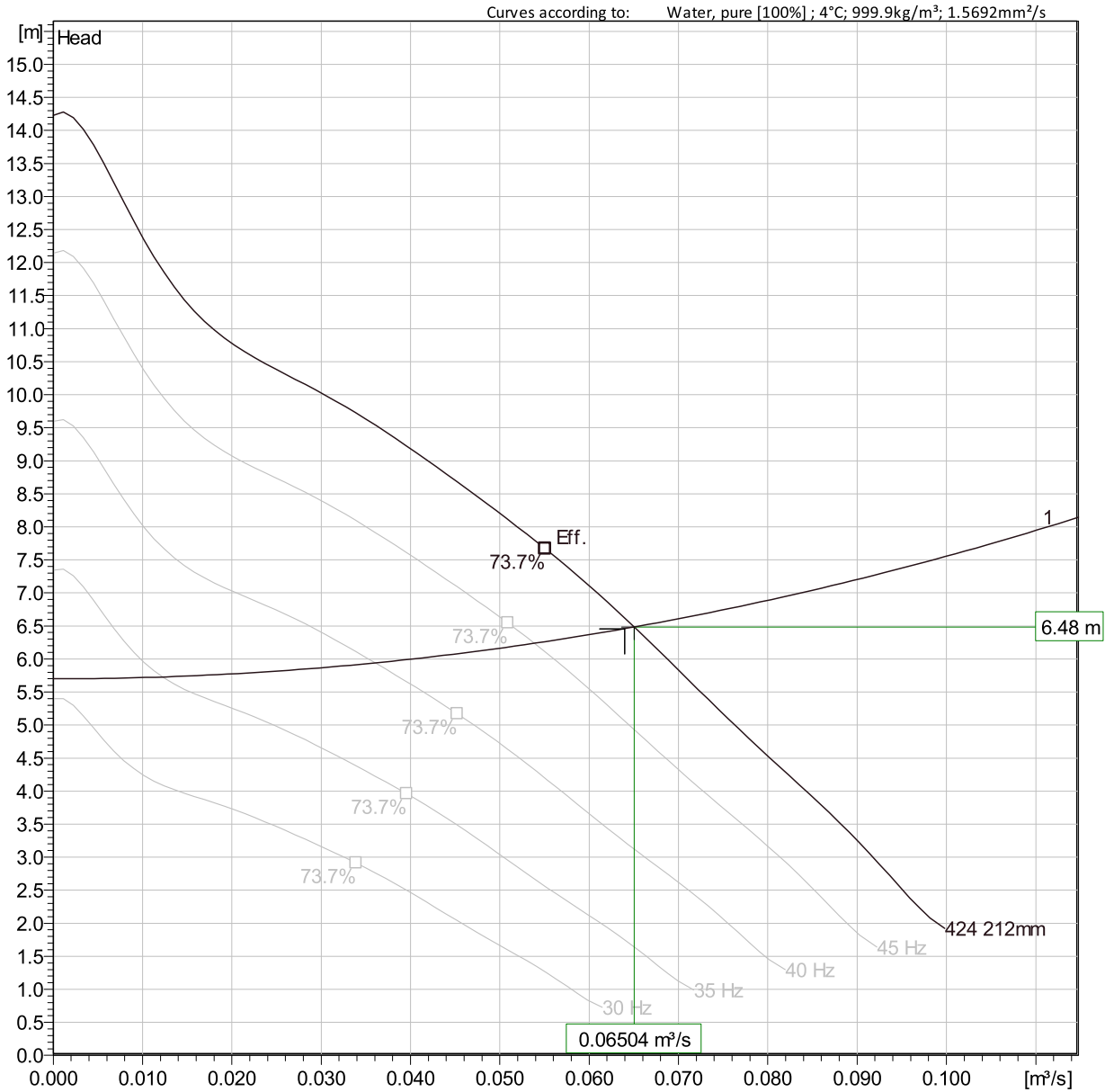

Operating Characteristics

| Pumps / Systems | Frequency | Flow | Head | Shaft power | Flow | Head | Shaft power | Hydr.eff. | Specific Energy | NPSHre |
|-----------------|-----------|--------------|--------|-------------|--------------|--------|-------------|-----------|-----------------|--------|
| 1 | 50 Hz | 0.065 m³/s | 6.48 m | 5.74 kW | 0.065 m³/s | 6.48 m | 5.74 kW | 71.9 % | 0.0283 kWh/rr | 3.66 m |
| 1 | 45 Hz | 0.0499 m³/s | 6.16 m | 4.1 kW | 0.0499 m³/s | 6.16 m | 4.1 kW | 73.7 % | 0.0262 kWh/rr | 2.95 m |
| 1 | 40 Hz | 0.0317 m³/s | 5.89 m | 2.68 kW | 0.0317 m³/s | 5.89 m | 2.68 kW | 68.2 % | 0.0274 kWh/rr | 2.47 m |
| 1 | 35 Hz | 0.00928 m³/s | 5.72 m | 1.75 kW | 0.00928 m³/s | 5.72 m | 1.75 kW | 29.5 % | 0.0636 kWh/rr | |
| 1 | 30 Hz | | | | | | | | | |

| | | |
|---------|---------------------|-------------|
| Project | Created by | Last update |
| Block | Created on 6/4/2020 | |

NP 3127 LT 3~ Adaptive 424

Dimensional drawing

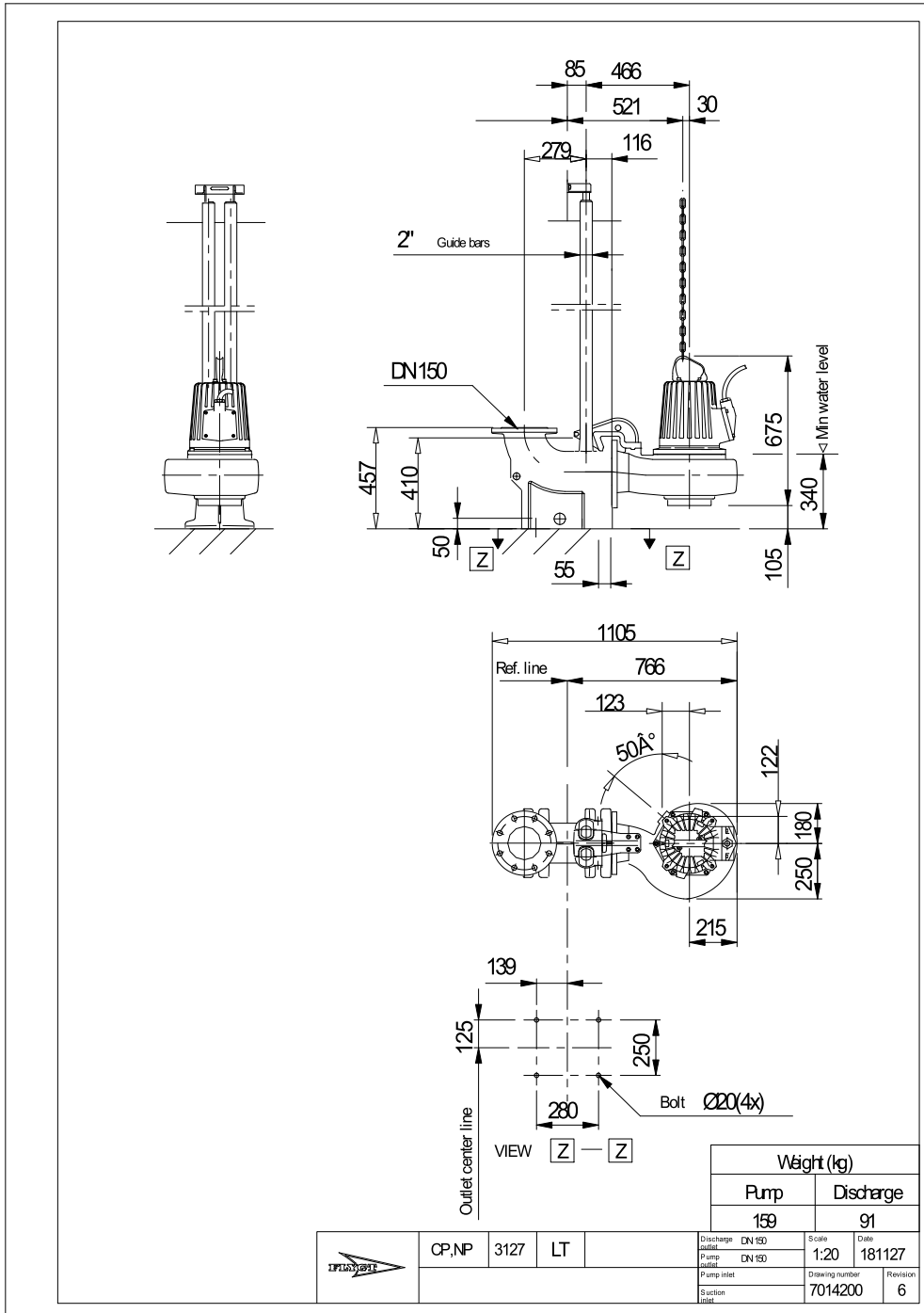

Project
Block

Created by
Created on 6/4/2020

Last update



ITT | Flygt

TOP 4 (Duplex Station)

(Fiberglass Station - 3068 thru 3127)

TOP Pump Station

Issued: 10/07

Supersedes: 08/07

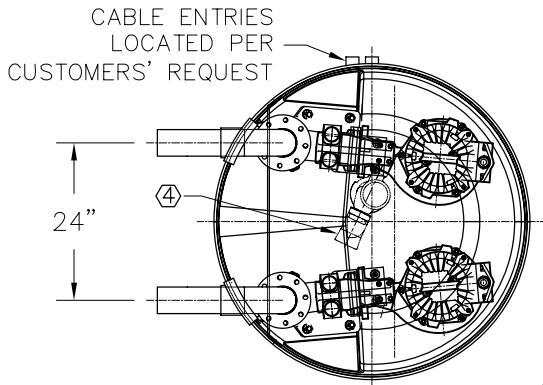

NOTE:

1. PUMPS AND CONTROLS ARE NOT SUPPLIED WITH THE TOP PUMP STATION AND MUST BE ORDERED SEPARATELY.
2. PUMP STATION WITH TWO (2) VENT PIPES IS AN AVAILABLE OPTION.
3. IMPELLERS 47x ONLY.
4. MIX FLUSH VALVE MUST BE LOCATED BETWEEN PUMPS.
5. REFER TO INSTALLATION, CARE AND MAINTENANCE MANUAL FOR BALLAST REQUIREMENTS.

SEE ACCESSORIES SECTION FOR PORTABLE HOIST (OPTIONAL)

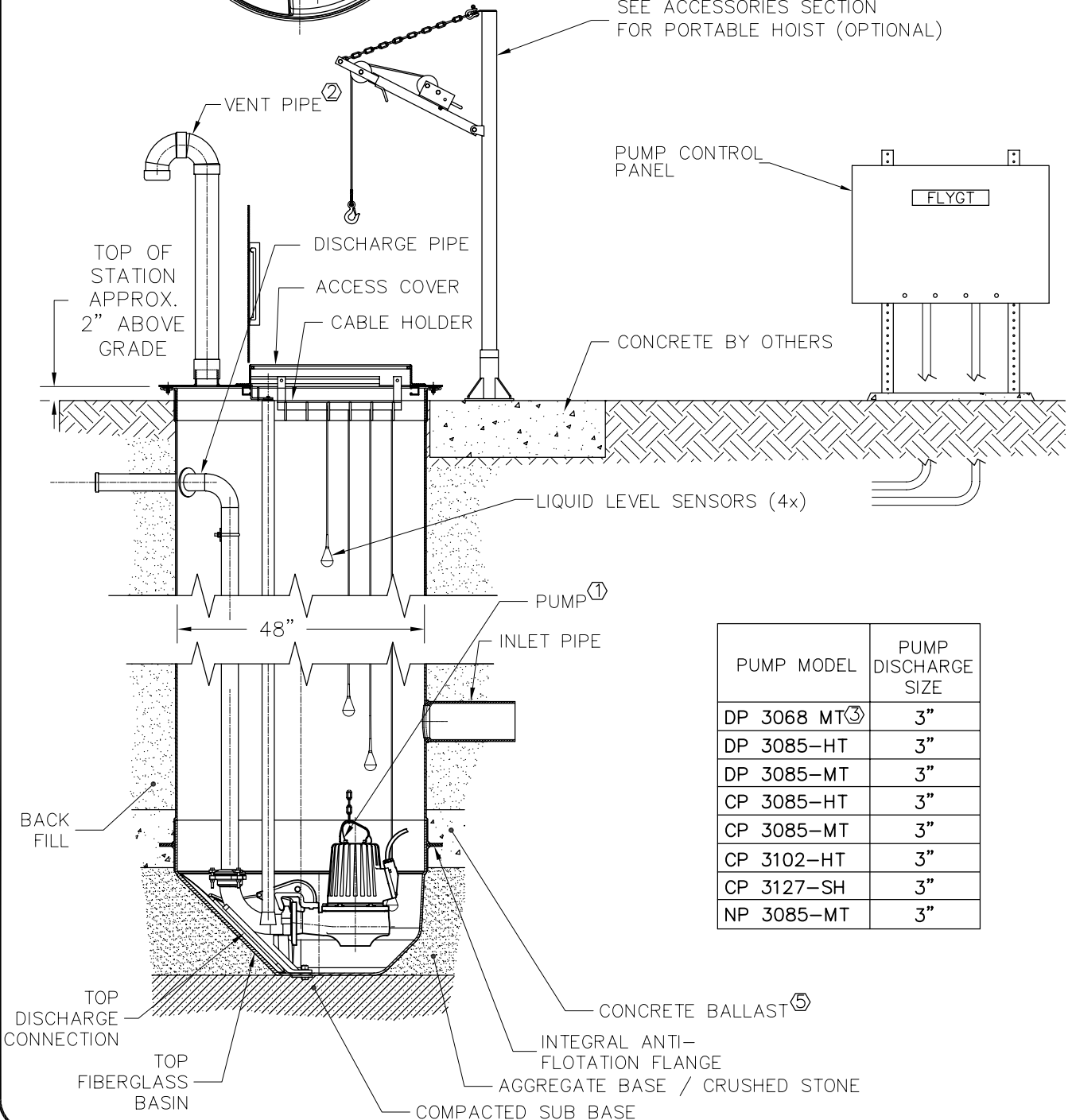

| PUMP MODEL | PUMP DISCHARGE SIZE |
|--------------|---------------------|
| DP 3068 MT ③ | 3" |
| DP 3085-HT | 3" |
| DP 3085-MT | 3" |
| CP 3085-HT | 3" |
| CP 3085-MT | 3" |
| CP 3102-HT | 3" |
| CP 3127-SH | 3" |
| NP 3085-MT | 3" |



TOP Pre-engineered Fiberglass Pump Station

THE OPTIMUM PUMP STATION

FLYGT
a xylem brand

TOP Station Premium Pre-engineered Pump Station

The Flygt TOP fiberglass pump station from Xylem is a premium, pre-engineered and factory built packaged pump station that utilizes advanced features to provide customers with superior pump station performance.

The innovative, self-cleaning, TOP Station sump bottom directs the solids and debris normally found in wastewater to the inlet of the Flygt N-Pumps where they can be effectively pumped away.

The interior of the pump station has a smooth finish which helps inhibit the build-up of grease and sludge.

The outside diameter of the station is equipped with an integral anti-flotation ring utilized to secure the station.

The aluminum pump station lid utilizes an integral Safe-Hatch access cover that provides personnel fall-through protection when the aluminum access door is opened. The raised frame provides a kick plate surround eliminating the possibility of tools or debris rolling into the pump station.

During normal inspection, individual pumps can be raised and placed upon one of the closed Safe-Hatch grates and washed-down. The debris will fall back down into the sump resulting in a clean pump to check.

Flygt Pump Station Controls



Xylem offers a fully engineered control panel solution. Our integrated, purposely designed control panels provide an intuitive user interface with the reliability you have come to expect from the leader in submersible pumping.

Standard Control Features

- UL 508 listed
- NEMA 4X 304 Stainless Steel enclosure with aluminum dead front inner door
- Lockable enclosure
- Hand/Off/Auto Selector switches
- Full voltage across-the-line starting
- Main incoming power circuit breaker
- Individual pump circuit breakers
- NEMA rated motor starters w/overloads
- Mini-CAS II pump seal & motor thermal protection
- MultiSmart™ intelligent pump station controller
- Current transformers
- 24VDC power supply
- ENM-10 float regulators

Available Options

- Generator receptacle and plug assembly with manual transfer switch
- Solid state reduced voltage starting
- LS-100 submersible pressure transducer
- MIO module and multi-sensor level probe
- Horn or bell audible alarm
- Anti-condensation heater and thermostat
- Back up floats (2 x ENM-10, when transducer or probe option is selected)
- Elapsed time meters for pumps
- TD-33 Telephone modem
- 12" x 10" space in panel reserved for future telemetry

Features & Benefits

- Pre-engineered, factory built pump station
 - Available in 4-ft, 5-ft or 6-ft diameters
- Heavy-wall filament-wound fiberglass tank
- Exclusive self-cleaning TOP sump bottom
- Flygt heavy-duty submersible N-Pumps
 - Clog-free, innovative technology
 - 3-hp through 35-hp motors
 - Self-cleaning N-Impeller
 - Sustains high hydraulic efficiency
- Flygt mix-flush valve
 - Provides sump mixing
 - Re-suspends solids
- 2", 3", 4" or 6" diameter discharge pipe
 - PVC discharge pipe
 - Stainless steel discharge pipe
- Stainless steel guide bars
- Stainless steel upper guide bar bracket
- Stainless steel cable holder hooks
- Integral Safe-Hatch aluminum access cover
- Flygt Grip-eye easy lift pump retrieval system
- 4-in diameter PVC station vent pipe
- Pump station level control choices
 - Flygt ENM-10 ball float-type
 - Flygt LS-100 pressure transducer-type
 - Flygt probe-type
- Duplex Flygt pump station controls
 - NEMA-4 enclosure
 - Several enclosure material choices
 - UL listed control available
 - NEMA or IEC rated starters available
 - Standard and custom controls
- Single lift, easy station installation
- Single-source responsibility



Fully sealed station wall penetrations can be factory installed for the influent pipe, discharge pipes, and electrical connection points. Depending on pipe diameter, properly selected fiberglass hubs with link seals are utilized. Influent pipe wall penetration can be shop installed or field located.

Flygt TOP Pre-engineered Pump Station

Grip-eye lifting device

Safe-Hatch access cover

Flygt N-Pump

Flygt Mix-flush valve

4" station vent pipe

Stainless steel guide bars

Heavy-wall construction

Level control system

TOP self-cleaning basin



xylem
Let's Solve Water

Xylem, Inc.
14125 South Bridge Circle
Charlotte, NC 28273
Tel 704.409.9700
Fax 704.295.9080
855-XYL-H201 (855-995-4261)
www.xyleminc.com

Flygt is a brand of Xylem, whose 12,000 employees are addressing the most complex issues in the global water market.

www.xyleminc.com

Installation, Care & Maintenance

TOP Pre-engineered Packaged Pump Stations

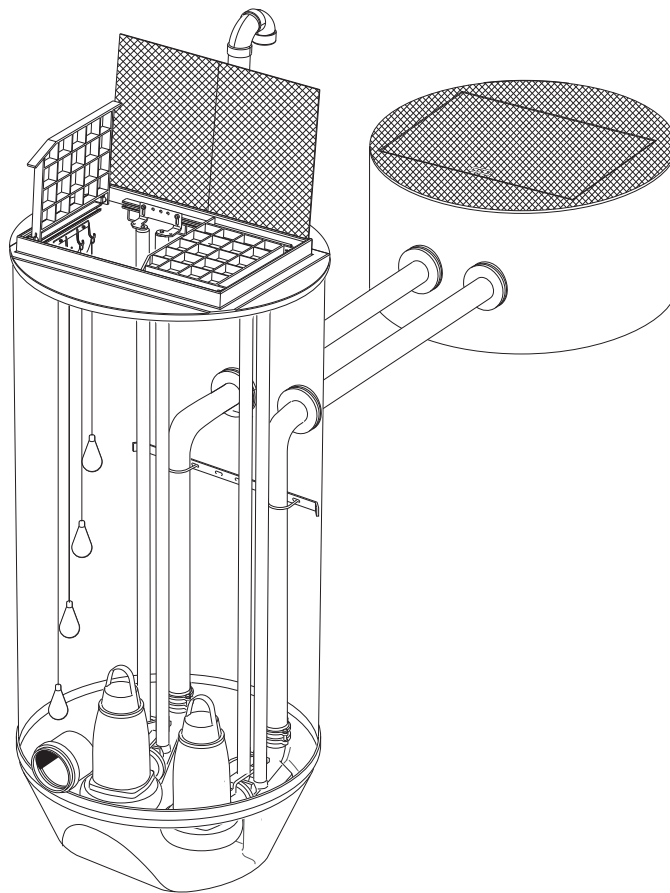

TOP 4, TOP 5 & TOP 6

CONTENTS

| | | | |
|---|----|---|----|
| Safety _____ | 4 | Installation of the air vent pipe _____ | 20 |
| Guarantee _____ | 5 | Installation of the level regulators _____ | 20 |
| Product description _____ | 6 | Installation of the pump _____ | 20 |
| Introduction _____ | 6 | Start up and operation _____ | 21 |
| Application _____ | 6 | Before installation _____ | 21 |
| Materials _____ | 7 | Start-up check _____ | 22 |
| External loads _____ | 7 | Care and maintenance _____ | 23 |
| Pipe material _____ | 7 | Part List _____ | 24 |
| Weight _____ | 7 | Cross Sectional View with call outs _____ | 24 |
| Diagram of typical installation _____ | 8 | Part numbers for TOP 4, 3" _____ | 26 |
| Transportation and storage _____ | 9 | Part numbers for TOP 5, 3" _____ | 28 |
| Installation _____ | 10 | Part numbers for TOP 5, 4" _____ | 30 |
| Safety precautions _____ | 10 | Part numbers for TOP 6, 4" _____ | 32 |
| General _____ | 10 | Part numbers for TOP 6, 6" _____ | 34 |
| Handling _____ | 10 | | |
| Elevation adjustment _____ | 11 | | |
| Site preparation & concrete ballast _____ | 12 | | |
| Concrete placement _____ | 12 | | |
| Before backfilling _____ | 14 | | |
| Soil backfill, backfill envelope and soil compaction _____ | 14 | | |
| Flexible connector _____ | 14 | | |
| Concrete _____ | 14 | | |
| Backfilling time after casting anchor _____ | 14 | | |
| Field repairs and level changes _____ | 14 | | |
| Soil properties _____ | 15 | | |
| Electrical connections _____ | 16 | | |
| Pump station grounding _____ | 16 | | |
| Inlet Wall Penetrations _____ | 17 | | |
| Flexible entry boot _____ | 17 | | |
| Cast iron caulking hub _____ | 19 | | |

SAFETY

This manual contains basic information on the Installation, Operation and Maintenance and should be followed carefully. It is essential that these instructions are carefully read before installation or commissioning by both the installation crew as well as those responsible for operation or maintenance. The operating instructions should always be readily available at the location of the unit.

Identification of safety and warning symbols



General Danger:

Non-observance given to safety instructions in this manual, which could cause danger to life have been specifically highlighted with this general danger symbol.



High Voltage:

The presence of a dangerous voltage is identified with this safety symbol.

WARNING!

Non-observance to this warning could damage the unit or affect its function

Qualifications of personnel

An authorized (certified) electrician and mechanic shall carry out all work.

Safety regulations for the owner/operator

All government regulations, local health and safety codes shall be complied with.

All dangers due to electricity must be avoided (for details consult the regulations of your local electricity supply company).

Unilateral modification and spare parts manufacturing.

Modifications or changes to the unit/installation should only be carried out after consulting with ITT Flygt.

Original spare parts and accessories authorized by the manufacturer are essential for compliance. The use of other parts can invalidate any claims for warranty or compensation.

The pictures in this manual may differ somewhat from the delivered pump station depending on size and configuration.

GUARANTEE

ITT Flygt undertakes to remedy faults in products sold by ITT Flygt provided that:

- the fault is due to defects in design, materials or workmanship;
- the faults are reported to ITT Flygt or ITT Flygt's representative during the guarantee period;
- the product is used only under conditions described in the Installation, Care and Maintenance manual and in applications for which it is intended;
- the monitoring equipment incorporated in the product is correctly **connected** and **in use**;
- all service and repair work should be done by ITT Flygt Authorized service personnel;
- genuine ITT Flygt parts are used.

Hence, the guarantee does not cover faults caused by deficient maintenance, improper installation, incorrectly executed repair work or normal wear and tear.

ITT Flygt assumes no liability for either bodily injuries, material damages or economic losses beyond what is stated above.

PRODUCT DESCRIPTION

Introduction

In this Installation, Care and Maintenance manual you will find information on how to handle, install and maintain the pump station to give it a long and reliable life.

The pump is installed by means of twin guide bars with automatic connection to the permanently installed discharge connection at the bottom of the sump.

The unique design of the sump and the integrated pump discharge connections has been hydraulically optimized to improve the flow over the sump floor during pumping. This increases turbulence and causes re-suspension of settled solids and entrainment of floating debris. The result: more solids are removed from the sump, leaving minimal residue beneath the pumps which is ready to be removed during the next pumping cycle.

Application

This pump station is intended to be used for;

- pumping of wastewater-domestic, commercial or industrial
- pumping of raw or clean water

For further information on applications, contact your nearest ITT Flygt representative.

Pump station depth: max. 20 ft.

Materials

The pump station is fabricated of Fiberglass Reinforced Plastic (FRP), i.e. thermosetting resins incorporating reinforcement materials and processing agents and possibly fillers and/or additives.

Design Criteria

The pump station is designed in respect of a subsoil water table up to the ground level.

The pump station carries a pedestrian load rating and shall be installed in such a way that traffic load can not get closer than 3 ft. from the tank edge.

Pipe material

The pump station is available with piping in stainless steel, PVC or ductile iron.

The guide bars are available in galvanized steel or stainless steel.

Weight

Approximate total weight (lb.) of pump station excluding pumps:

| Table 1 PUMP STATION WEIGHT | | | |
|-----------------------------|---------------------|---------------------|---------------------|
| Station Depth (ft.) | TOP 4 Weight (lbs.) | TOP 5 Weight (lbs.) | TOP 6 Weight (lbs.) |
| 5 | 1070 | 1280 | 1540 |
| 10 | 1480 | 1890 | 2430 |
| 15 | 2040 | 2810 | 3630 |
| 20 | 2500 | 3490 | 4560 |

Note: All weights assume the use of ductile iron piping within the station and are approximate. Actual station weight will be marked on the outside of the station prior to shipment.

TYPICAL INSTALLATION

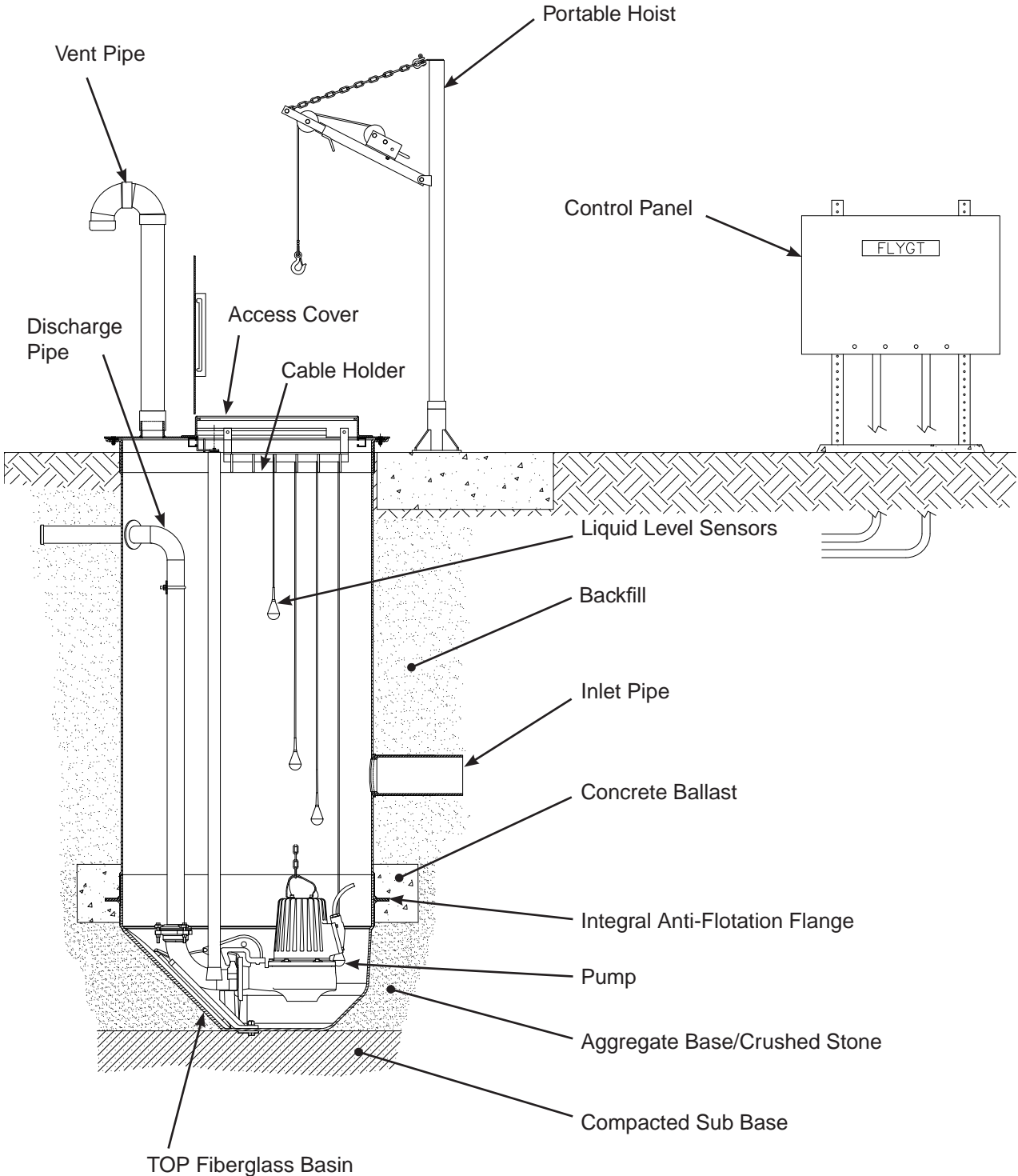

TRANSPORTATION AND STORAGE

The pump station is delivered in a horizontal position. Make sure that the station is unloaded from the truck with a suitable crane or lifting equipment.



Always lift the pump station by the appropriate load-rated lifting straps.

Do not use chain as chain may damage the station.

Unload and put it down carefully on the ground.

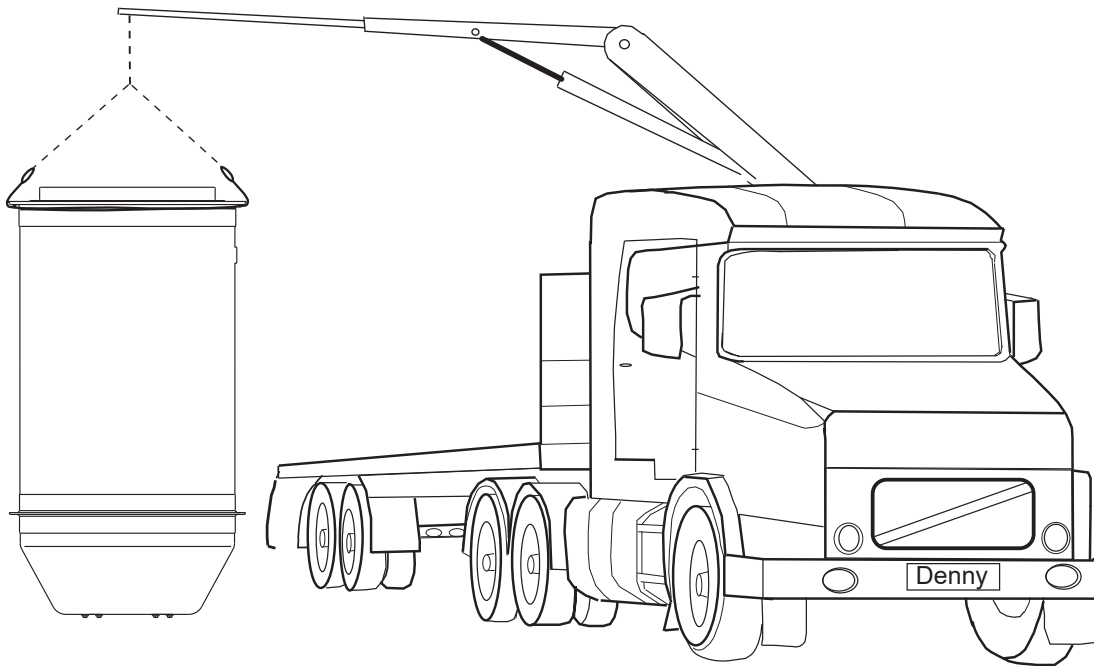

If the pump station shall be stored for some time before installation – keep it in a horizontal position!

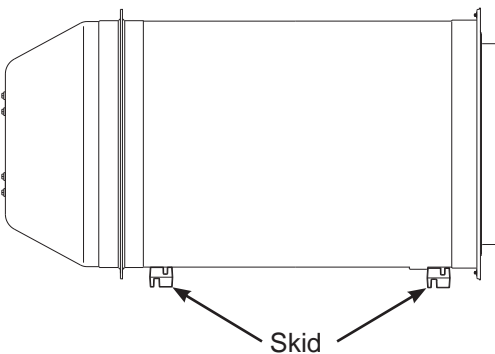

- **The pump station and pumps are delivered separately.**
- **Never install the pumps before the pump station is permanently installed.**
- **Make sure that pump station cannot roll over or fall.**

INSTALLATION

Safety precautions

In order to minimize the risk of accidents in connection with transportation and installation work the following rules should be followed:



- **Always pay extra attention to safety aspects when working with lifting equipment.**
- **Never work alone.**
- **Use safety helmet and protective shoes.**
- **Make sure that the lifting equipment is approved and in good condition.**
- **Check that the lifting straps are in good condition.**
- **Stay clear of suspended loads.**
- **Read the installation, care and maintenance manuals for pumps and other equipment.**
- **Follow all other health and safety rules and local codes and ordinances.**

General

The responsibility for installing the pump station is always borne by the installing contractor.

ITT Flygt's Top pre-engineered fiberglass pump station packages are designed for installation with a bottom concrete ballast poured in place at the bottom of the straight shell. The following instructions are an efficient and economical method for installing ITT Flygt's Top pre-engineered fiberglass pump stations. Follow all applicable local and national codes. The installer is responsible to comply with OSHA regulations and all other safety requirements.

Handling

Contractor shall take due care in handling the ITT Flygt's Top pre-engineered fiberglass pump station package.

Please be aware of the following restrictions:

- **Do not** drop or impact the pump station.
- **Do not** use chain or steel cables in direct contact with the fiberglass. Store pump station in a horizontal position using the included shipping skids or chocks such as tires, sand bags or other pliable materials.
- **Do not** permit pump station to rest on large solid objects such as rocks, wood, brick, blocks, and so forth.
- **Do not** permit the pump station to be moved by rolling.
- **Do not** roll or set the pump station on any pipe stubout, accessory or appurtenance installed on the pump station.

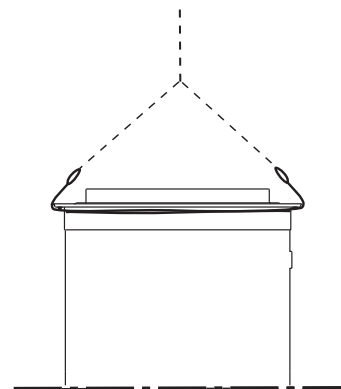

Elevation adjustment

If necessary, use shims in the excavation to adjust pump station to correct elevation. Shims can be of any appropriate material that will not degrade, cause locally high contact stresses to the pump station, or rot. An examples of an appropriate shim would be sand bags.



- **When raising from horizontal to upright position the pump station will jolt and possibly sway slightly towards the end of the raising position.**
- **To avoid accidents, stand at a safe distance until this movement has stopped!**
- **Place the pump station on a rigid horizontal surface and make sure it cannot fall.**

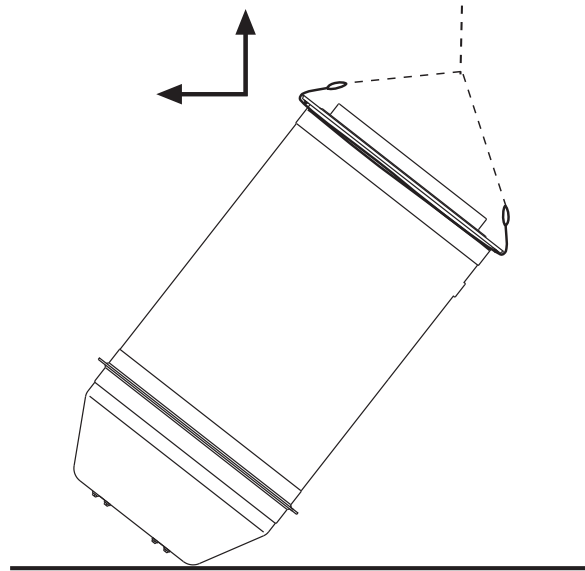

Site preparation & concrete ballast

Provide adequate working room around the pump station. See diagram below and tables on page 13 for concrete ballast dimensions. The concrete ballast shall be reinforced as required by local codes.

Concrete ballast design should be sufficient to resist head pressure and soil loading with pump station completely empty and water to grade. Refer to tables 2.3 and 4 for the required concrete ballast dimensions.

Concrete placement

Do not let concrete free fall to bottom of hole more than 3 to 4 feet. Place concrete using a tremmy chute to help preclude segregation of the aggregate from the matrix. Ensure that concrete flows under the fiberglass anti-flotation flange. Consolidate concrete with proper vibration per the recommended practice of ACI 318-05 section 5.10.

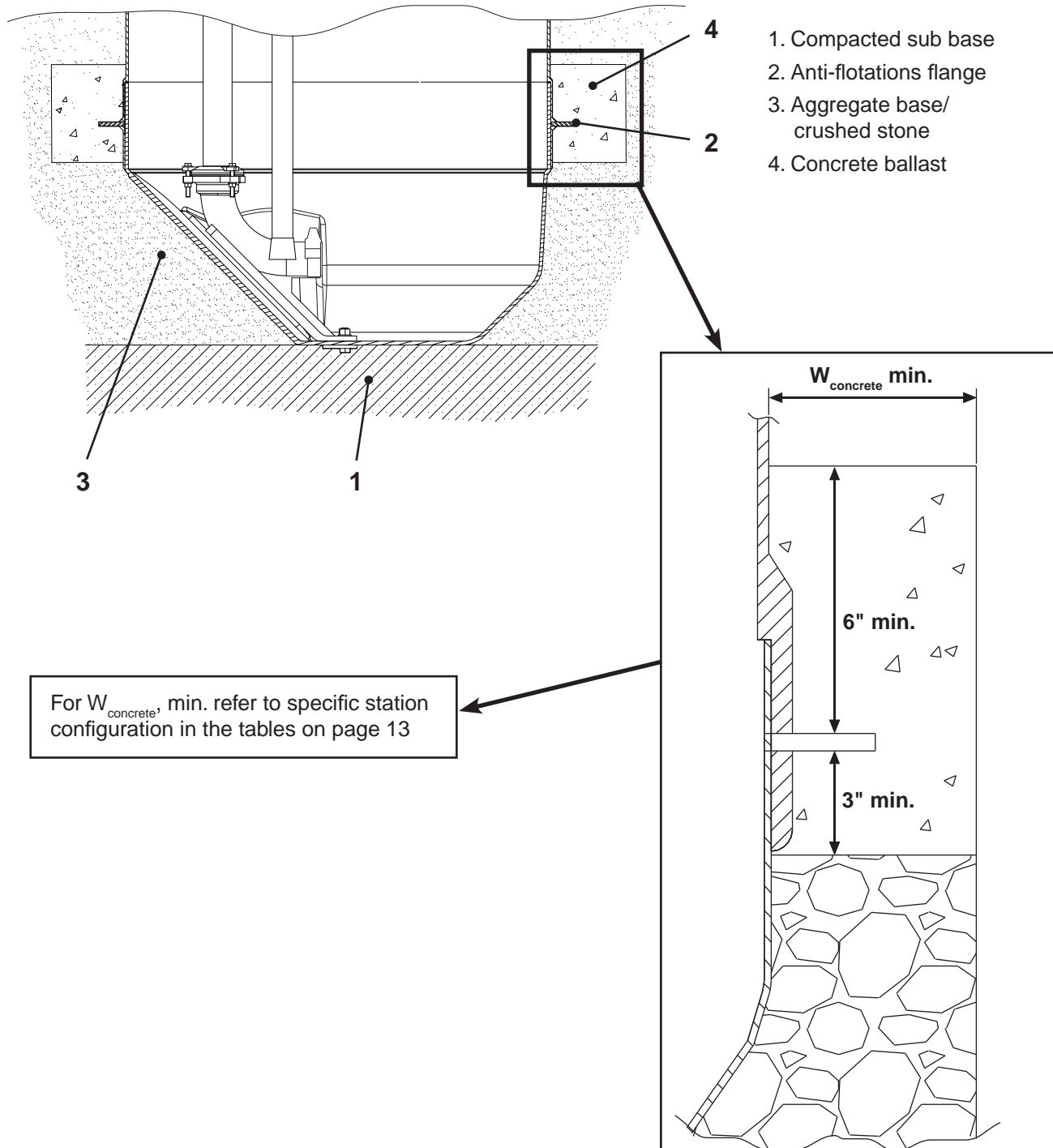

| Table 2 | | TOP 4 | |
|----------------|----------------|---------------------------|---|
| Station type | Diameter (in.) | Overall tank length (in.) | Concrete Ballast Requirements |
| | | | W_{concrete}, Width of concrete ballast ring |
| Top 4 | 48 | 60 | Ballast not required |
| | 48 | 72 | Ballast not required |
| | 48 | 84 | Ballast not required |
| | 48 | 96 | Ballast not required |
| | 48 | 108 | 3" min. |
| | 48 | 120 | 4" min. |
| | 48 | 132 | 5" min. |
| | 48 | 144 | 5" min. |
| | 48 | 156 | 6" min. |
| | 48 | 168 | 6" min. |
| | 48 | 180 | 7" min. |
| | 48 | 192 | 7" min. |
| | 48 | 204 | 8" min. |
| | 48 | 216 | 8" min. |
| | 48 | 228 | 9" min. |
| | 48 | 240 | 10" min. |

| Table 4 | | TOP 6 | |
|----------------|---------------------------|-------------------------------|---------------------------------------|
| Diameter (in.) | Overall tank length (in.) | Concrete Ballast Requirements | |
| | | W_{concrete} | Width of concrete ballast ring |
| 72 | 60 | | Ballast not required |
| 72 | 72 | | 4" min. |
| 72 | 84 | | 5" min. |
| 72 | 96 | | 6" min. |
| 72 | 108 | | 6" min. |
| 72 | 120 | | 7" min. |
| 72 | 132 | | 8" min. |
| 72 | 144 | | 9" min. |
| 72 | 156 | | 10" min. |
| 72 | 168 | | 11" min. |
| 72 | 180 | | 11" min. |
| 72 | 192 | | 12" min. |
| 72 | 204 | | 13" min. |
| 72 | 216 | | 14" min. |
| 72 | 228 | | 15" min. |
| 72 | 240 | | 15" min. |

| Table 3 | | TOP 5 | |
|----------------|---------------------------|-------------------------------|---------------------------------------|
| Diameter (in.) | Overall tank length (in.) | Concrete Ballast Requirements | |
| | | W_{concrete} | Width of concrete ballast ring |
| 60 | 60 | | Ballast not required |
| 60 | 72 | | Ballast not required |
| 60 | 84 | | 3" min. |
| 60 | 96 | | 4" min. |
| 60 | 108 | | 5" min. |
| 60 | 120 | | 6" min. |
| 60 | 132 | | 6" min. |
| 60 | 144 | | 7" min. |
| 60 | 156 | | 8" min. |
| 60 | 168 | | 9" min. |
| 60 | 180 | | 9" min. |
| 60 | 192 | | 10" min. |
| 60 | 204 | | 11" min. |
| 60 | 216 | | 11" min. |
| 60 | 228 | | 12" min. |
| 60 | 240 | | 12" min. |

Before backfilling

Check that the pipe work and the electrical connections are well protected and supported during backfilling around the station so no load is applied to them by compaction operation.

Place crushed stone uniformly around the base to prevent sideways surge. The pump station shall be adequately braced to prevent movement either by sideways movement or by leaning.

Soil backfill, backfill envelope and soil compaction

Native soils suitable as backfill are shown in table 5. **Do not** use soils such as muck, bog, peat, and loess. The ideal backfill is well-graded sand, as this will compact relatively easily and typically retains its strength in submerged conditions. **Do not** use fine silts in areas subject to large seismic activity such as on the west coast in seismic zones 3 and 4 per the 1997 UBC. As a minimum ITT Flygt recommends using well-graded sand compacted to 95% standard proctor density, or crushed stone or pea gravel with size ranging from ¼ in to ¾ in. In these areas, install a filter fabric between the selected backfill and the native soil. At owner's option, consult local geotechnical engineer for determining adequate backfill material and compaction requirements in these areas.

Contact a qualified geotechnical engineer when installing ITT Flygt's Top pre-engineered fiberglass pump station packages in muck, bog, peat, and loess and/or for other difficult soil conditions or in areas such as e.g. a steep slope.

Do not permit ice to form in the backfill and keep backfill material as dry as practical by using adequate drainage techniques and good construction practices.

The size of the backfill envelope is dependent on the in situ soil properties. For native soils with an unconfined compressive strength (UCC) of 0.75 tsf or lower, or an allowable bearing capacity of 3500 psf or lower, the backfill shall extend one radius of pump station away from the pump station wall but not less than 2 ft. For soils exceeding these values the backfill envelope shall be 2 ft.

Compaction of the backfill is highly recommended and beneficial as this helps control long term settlement. See table 5 for compaction requirements and for additional information of soil stiffness and applicability as backfill material.

Flexible connector

Use flexible connectors for each stub-out to connecting pipe to help preclude stresses from long-term settling due to ground consolidation. These connectors should extend 2 stub-out diameters away from the stub-out pipe end.

Concrete

Concrete shall have a minimum 28-day compressive strength of 3000 psi and all reinforcing shall be ASTM A 615 grade 60. Place concrete using a tremie for free fall distances greater than about 3 to 4 feet. Ensure that concrete extends at least 6" above anti-flotation flange (anchor lip). Refer to figure on page 12.

Backfilling time after casting concrete ballast

Do not backfill until concrete ballast has gained sufficient strength to provide rigid support for both pump station and backfill (typically 1 to 2 days or as specified by EOR). Add backfill in 6 to 8 in lifts for proper compaction evenly all around pump station to avoid uneven backfill loads.

WARNING!

Pump station top is pedestrian rated only and is not designed for wheel loads or other heavy loads.

Field repairs and level changes

Pump stations can be damaged if not properly handled, installed or backfilled. If repair or modification work is required, contact your local ITT Flygt representative for instruction.

| | E' for degree of compaction of bedding, lb/in ² | | | |
|--|--|--|---|--|
| Soil type-pipe bedding material (Unified Classification System) | Dumped | Slight, <85% proctor, < 40% relative density | Moderate, 86% - 95% proctor, 40% - 70% relative density | High, >95% proctor, 70% relative density |
| Fine- grained soils (LL > 50) Soils with medium to high plasticity CH, MH, CH-MH | No data available, consult a geotechnical engineer; otherwise use E' = 0 | | | |
| Fine- grained soils (LL < 50) Soils with medium to no plasticity CL, ML, ML-CL, with less than 25% coarse-grained particles | 50 | 200 | 400 | 1000 |
| Fine grained soils (LL < 50) Soils with medium to no plasticity CL, ML, ML-CL with more than 25% coarse-grained particles. Coarse grained soils with fines GM, GC, SM, SC contains more than 12% fines | 100 | 400 | 1000 | 2000 |
| Coarse-grained soils with little or no fines GW, GP, SW, SP contains less than 12% fines | 200 | 1000 | 2000 | 3000 |
| Crushed Rock | 1000 | 3000 | 300 | 3000 |

- CH - Inorganic clays or high plasticity, fat clays.
- MH - Inorganic silts, micaceous or diatomaceous fine sand or silty soils, classic silts.
- CL - Inorganic clays of low to medium plasticity, gravelly clays, sandy clays, silty clays, lean clays
- ML - inorganic silts and very fine sands, rock flour, silty or clayey fine sands with slight plasticity.
- SC - Clayey sands, poorly graded sandy-clay mixtures.
- SM - Silty sands, poorly graded sand-silt mixtures.
- GC - Clayey gravels, poorly graded gravel and clay mixtures.
- GM - Silty gravels, poorly graded gravel-sand-silt mixture.

Do not use shaded area for backfill

Degrees of compaction

- Dumped – No compaction effort
- Slight – Some compactive effort. In-place density <less than 85% standard Proctor Density. Or less than 40% Relative Density
- Moderate – Intermediate level of compactive effort, In-place density greater than or equal to 85% and less than 95% standard Proctor Density, or greater than or equal to 40% and less than 70% Relative Density
- High – Considerable compactive effort, In-place density greater than 95% standard Proctor Density, or greater than or equal to 70% Relative Density

A slight degree of compaction can significantly add to soil density and long-term performance. Greater compaction improves installation and performance.

Definitions:

LL = Liquid Limit

Standard Proctor Density per ASTM D-698

Relative Density $D_r = (e_{max} - e) / (e_{max} - e_{min})$

Where $e = \text{void ratio} = V_v / V_s$

$V_v = \text{volume of voids}$

$V_s = \text{volume of solids}$

Electrical connections



- **All electrical work shall be carried out under the supervision of an authorized electrician.**
- **Local codes and regulations shall be complied with and shall be the responsibility of the electrical contractor.**
- **Before starting the work, check that the supply cable is de-energized.**

Install the control panel at the pump station so it is easily accessible during, operation, service and inspection.

Check the data plate on the pump to determine valid voltage supply.

Check that the main voltage and frequency agree with the specifications on the pump data plate.

Thoroughly read the Installation, care and maintenance manual delivered with the pump as well as the manual for the start- and control panel.

Run the cables through the cable entry to the control panel.

Use appropriate ITT Flygt support grips for the cables inside the pump station.

Connect the motor cables and cables for the level sensors as illustrated in the wiring diagrams following the control panel.



- **Bear in mind the risk of electric shock and the risk of explosion if the electrical connections are not correctly carried out!**
- **Follow the rules and recommendations in NFPA-70, "Protection against electric shock - common aspects for installation and equipment".**

Pump station grounding

The pump station has been prepared for grounding of the structure. A grounding strap has been installed, as part of the station, and connects the pump and pump guide rails to the station cover. A grounding lug has been included as part of the station cover, that lug shall be used to continue the path to ground. All ground connections shall be performed by licensed authorized personnel and shall be in accordance with local codes.

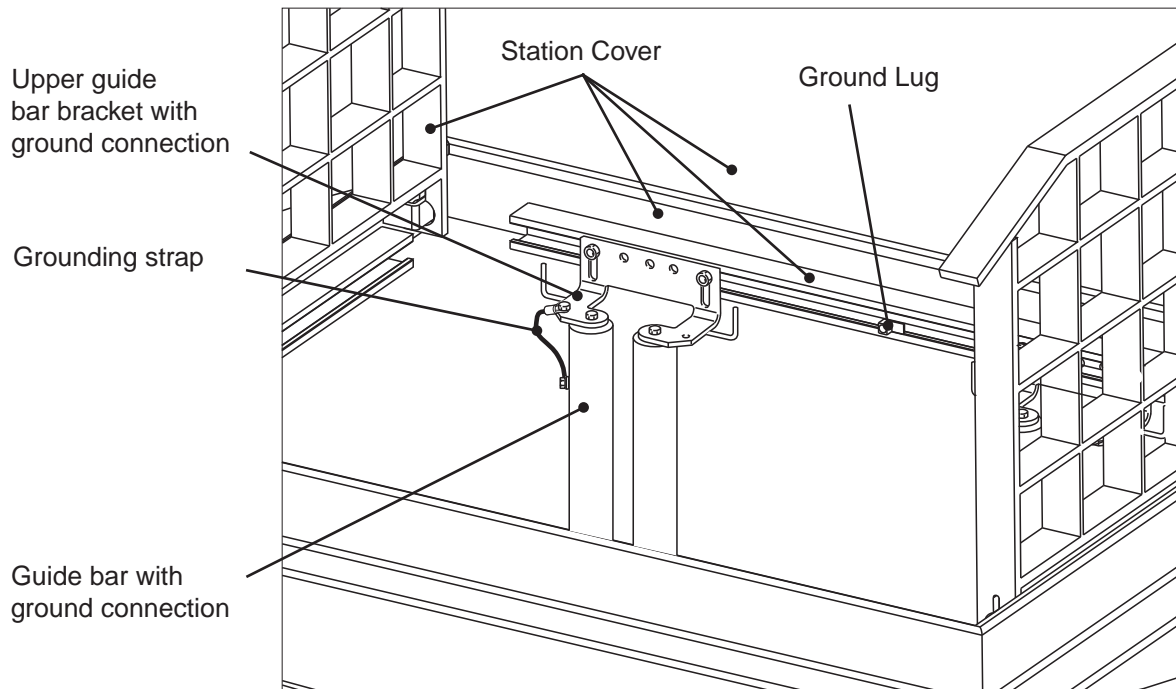

Inlet Wall Penetrations

Flexible entry boot

Installation instructions

For proper and warranted installation of flexible entry boots, these instructions must be followed. Prior to installing the rubber entry boots, make sure the exact location has been properly calculated.



Bolt Holes

Locate the center entry point in the flat wall section of the sump base and drill a 5/16" hole. Install the entry boot template to the sump base wall using a 1/4" bolt and nut. Drill out the appropriate bolt hole circle for the size boot to be installed using the same 5/16" drill bit. After drilling, remove the template from the sump base wall. For proper installation, the appropriate size fabrication template should be used for accurate hole drilling.



Boot Openings

After the bolt hole circle has been drilled, drill the entry boot opening by using the appropriate size hole saw. After the opening is drilled, clean any rough edges with a deburring tool or razor knife.



WARNING: The appropriate hole saw size must always be used for proper installation of the flexible entry boot. Failure to use the required hole saw could damage the rubber boot after installation or prevent the boot from sealing properly and void product warranty.

| Hole Saw | Flexibale Entry Boots |
|-----------|-----------------------|
| 4-1/4" | FEB-6300 (3") |
| 5-1/2" | FEB-7400 (4") |
| Saber Saw | FEB-8600 (6") |

Installing Rubber Boot

Install the rubber boot from outside the sump by inserting the studs through the bolt holes. From the inside of the sump, install the compression ring over the studs and install nuts by hand.



Boot Fastening

Using a 7/16" nut driver, tighten all of the nuts evenly in a clockwise sequence until 60 in.-lbs. is attained on all nuts. This may require two to three revolutions to achieve. To prevent deformation of the boot, do not overtighten nuts.



Clamp Fastening

Insert the appropriate sized pipe or conduit into the flexible boot from outside of the sump. After the pipe or conduit have been positioned, install the band clamp around the boot and tighten to 30 inch/lbs.



WARNING: Do not over tighten the band clamp beyond the maximum torque of 30 in.-lbs. or it is possible to damage the rubber boot.

Cast Iron caulking hub

Installation instructions, see figure below

Working from outside of the basin cut a hole in the basin wall at the desired location with a hole saw that is just large enough to accommodate diameter "A", see diagram below.

Using the caulking hub of the cast iron caulking hub as a template drill four (4) 3/8" holes through the basin wall at the four (4) locations on the caulking hub bolt hole circle "B", see diagram below.

Install gasket seal tape on the back of the caulking hub between diameter "A" and the bolt hole circle "B", see diagram below. If the caulking hub and basin do not mate well, an additional bead of silicone caulk may be required to ensure seal.

Install the cast iron caulking hub to the pump station wall and secure using four (4) machine screws, sealing washer and hex nuts.

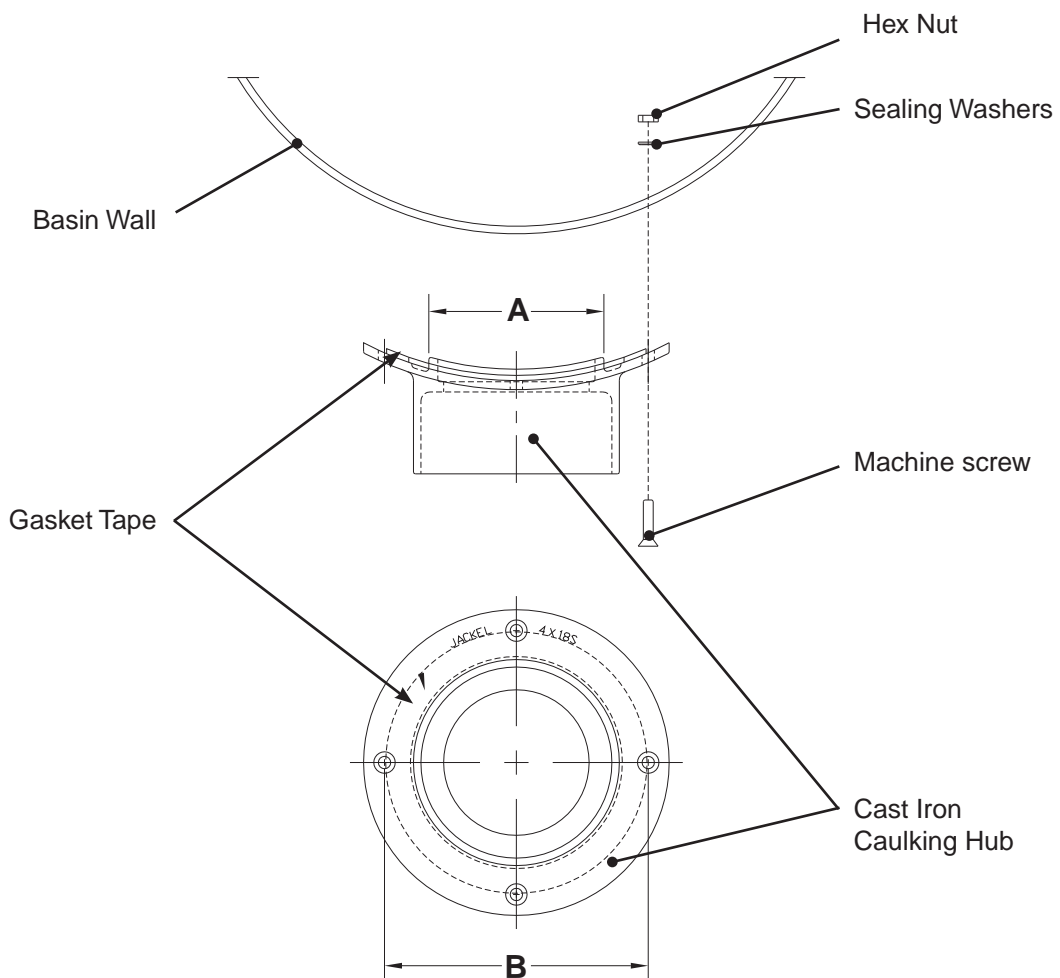

Installation of the air vent pipe

Each pump station is supplied with one (1) or two (2) vents, depending upon end-user's requirements. Each vent is a threaded 4" sch 40, PVC U-vent, which is shipped loose along with the station. The vent(s) must be assembled to the station prior to start-up.

Before installing the vent pipe assembly to the station, lubricate the PVC vent pipe threads with silicone spray or other lubricant applicable for PVC.

Thread the air vent pipe assembly into the threaded aluminum air vent coupling, which is located on the station cover.

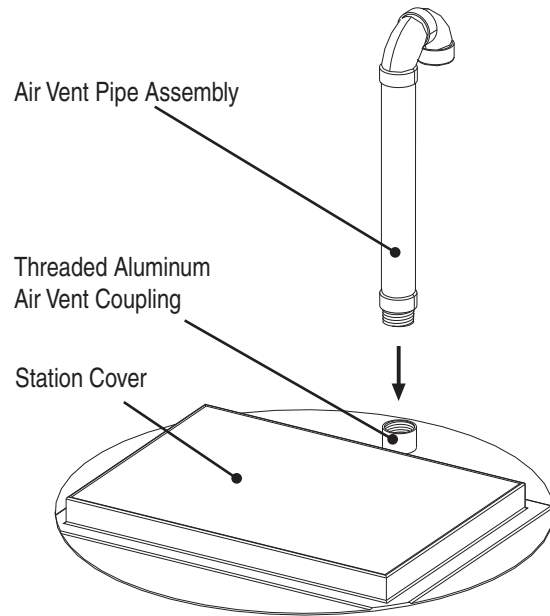

Installation of the level regulators

Use appropriate support grips for the ITT Flygt ENM-10 level regulator cables and hang them on the cable holder. Adjust the height of the level regulators according to the installation drawing.

If another type of level sensor is used please refer to the installation manual provided with that device.

Installation of the pump

Lower the pump along the guide bars.

Upon reaching its bottom position, the pump will automatically connect to the pre-assembled discharge connection.

When needed the pump can be hoisted up along the guide bars for inspection without the need for personnel to enter the station.

Fasten the lifting chain and the motor cables on the cable holder. Use appropriate ITT Flygt support grips for the cables.

- Make sure that the cables are not sharply bent or pinched.

START UP AND OPERATION

Before installation

The pump station is delivered pre-fabricated complete with discharge connection, pipes, guide bars and other mechanical and electrical equipment.

- When opening the station – check that the top cover and safety grid is properly supported. Note the risk of injury caused by crushing.
- Check that all equipment inside the station is properly fastened and in correct position after the transport and installation in the ground.
- Check all electrical connections.
- Check that the guide bars are placed vertically by using a level or plumb line.
- Carefully read the installation, care and maintenance manual for the pump as well as for the control panel.
- **IMPORTANT! Clean out any debris from the sump bottom.**

Start-up check

During start-up the following checks should be performed:

- Check to insure that the ground connections between the pump guide rails and the upper guide bar bracket are secure. See figure on page 16
- When the pumps operate does the water level go down?
- Do the floats or level sensor operate the pumps?
- What are the static and operating voltages at the pump control?
- What is the current draw, per leg, during pump operation?
- Does the impeller rotate in the correct direction when power is applied?
- Are there indications of blow-by or recirculation when the pump is in operation?
- Do the check valves operate correctly when the pump starts and stops?
- Does the pump perform appropriately as determined by the controls?
- Does the pump turn off if the thermal sensor indicates an overtemp condition? (Simulated during start-up by pulling sensor wires from the control box.)

CARE AND MAINTENANCE

The unique design of the bottom basin of the TOP pump station significantly helps to maintain problem-free pump operation and reduces the need for maintenance of the pump station. It is still recommended that the inside of the pump station, valves, level sensors and pipes are kept as clean as possible. Inspections should determine if and when any maintenance effort is required. ITT Flygt can also provide other ancillary equipment to further improve the operation;

- The Mix-Flush valve is recommended to enhance the removal of floating debris and settling deposits. It can be fitted on all standard ITT Flygt wastewater pumps. The valve operation is automatic. At each pump start the valve opens and water is forced through the valve in a powerful jet stream for a preset time. The jet sets the water in the tank into turbulent motion so that sludge deposits and floating solids are mixed in and can be pumped out.

- APP521 equipped control panel provides a unique functionality, it enables a cleaning cycle during which the pump draws down the water level to the verge of ingesting air. This is detected by the APP521 ability to precisely monitor changes in motor current. As the water level drops, both settling and floating solids are being removed by the pump, which maintains a clean station without any manual intervention. The frequency of the cleaning cycle can be pre-programmed to suit the specific site needs for each TOP pumping station.

Check with your local ITT Flygt representative for more detailed information.

Recommendations for preventive maintenance programs and/or service intervals for the actual pumps, level sensors and control panel are given in separate manuals provided with these products.

ITT Flygt disclaims all responsibility for work done by untrained, unauthorized personnel!

The following points are important in connection with work on the pumping station and associated equipment:



- **Beware of the risk of injury caused by crushing.**
- **If entering the pump station beware of the risk of hazardous gases and always use breathing apparatus.**
- **Check regularly that the lifting equipment is in good condition.**
- **Make sure that all electrical equipment is insulated from the power supply and cannot be energized.**

- **Make sure that the equipment has been thoroughly cleaned.**
- **Beware of the risk of infection.**
- **Follow local safety regulations.**
- **Always wear goggles and rubber gloves.**
- **Always close and lock the cover before leaving the pump station.**

For any fault tracing - carefully follow the recommendations in the Installation, Care and Maintenance manuals for the actual pump and control panel.

TOP 4, 5 & 6

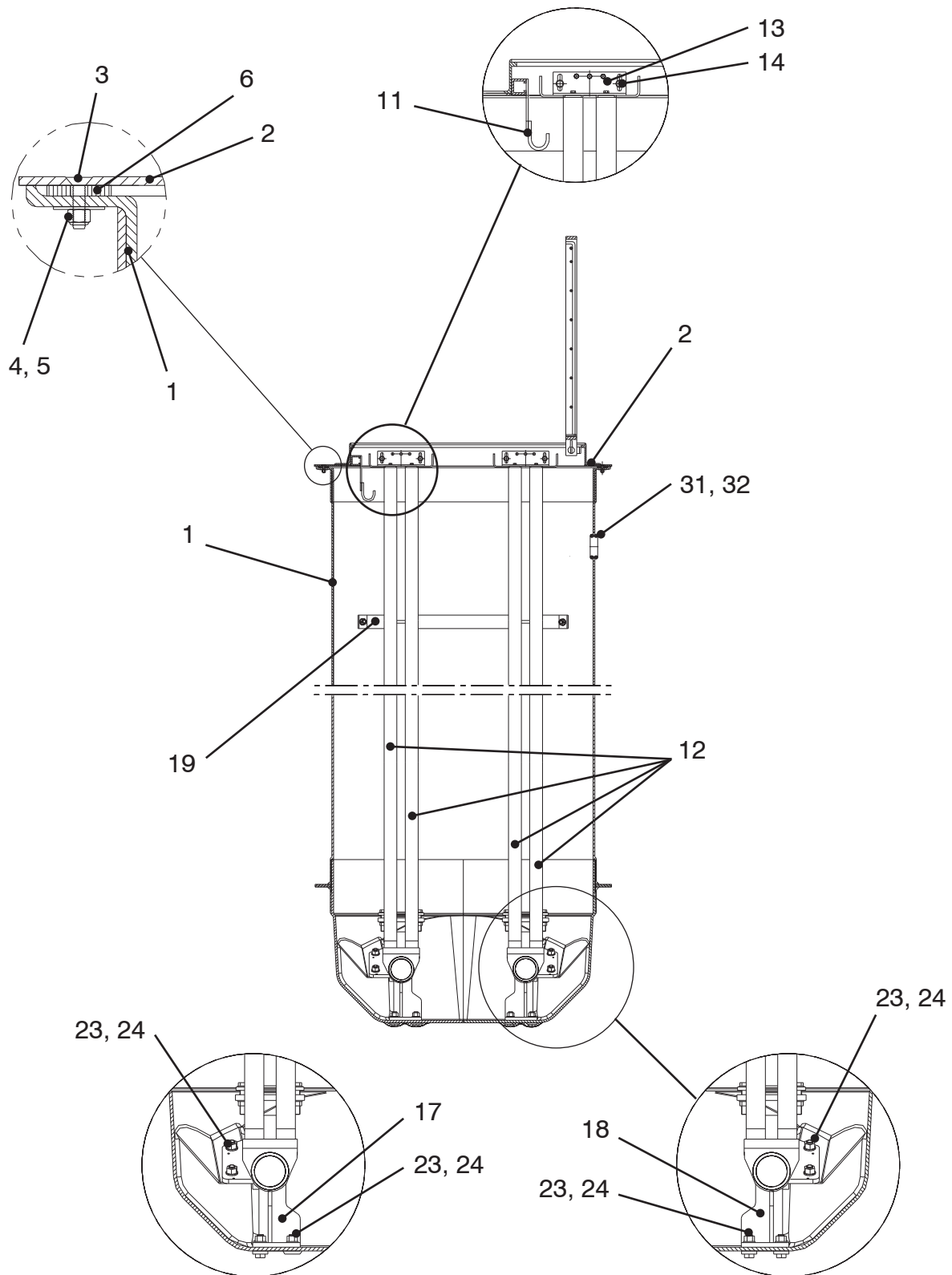

TOP 4, 5 & 6

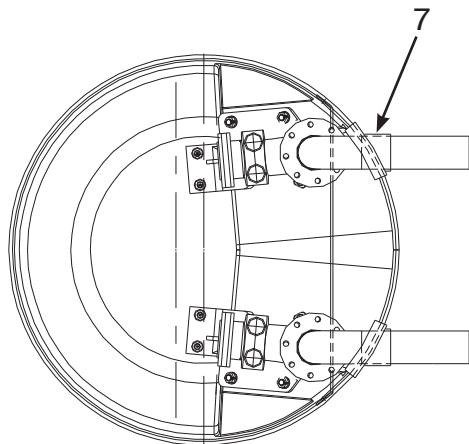
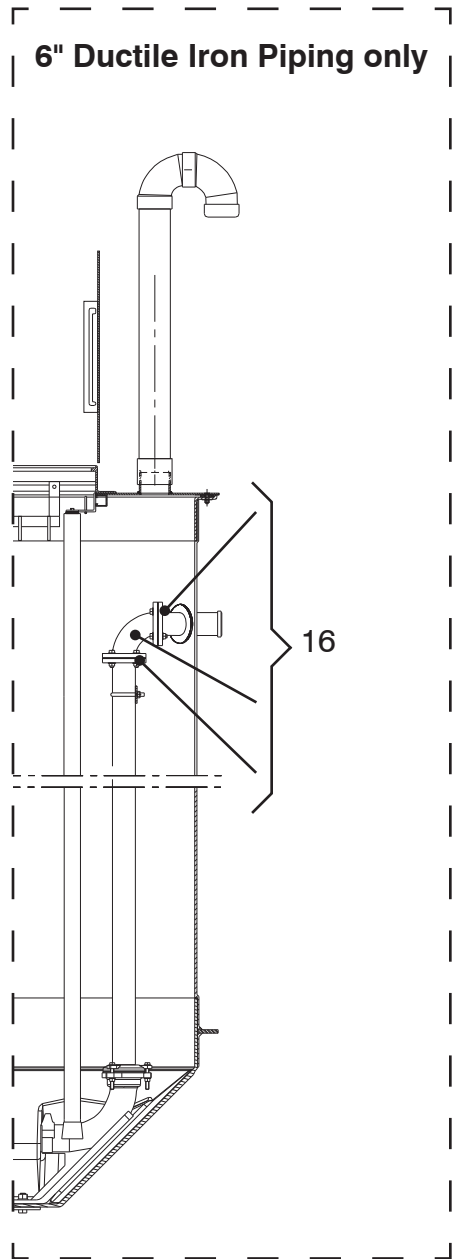
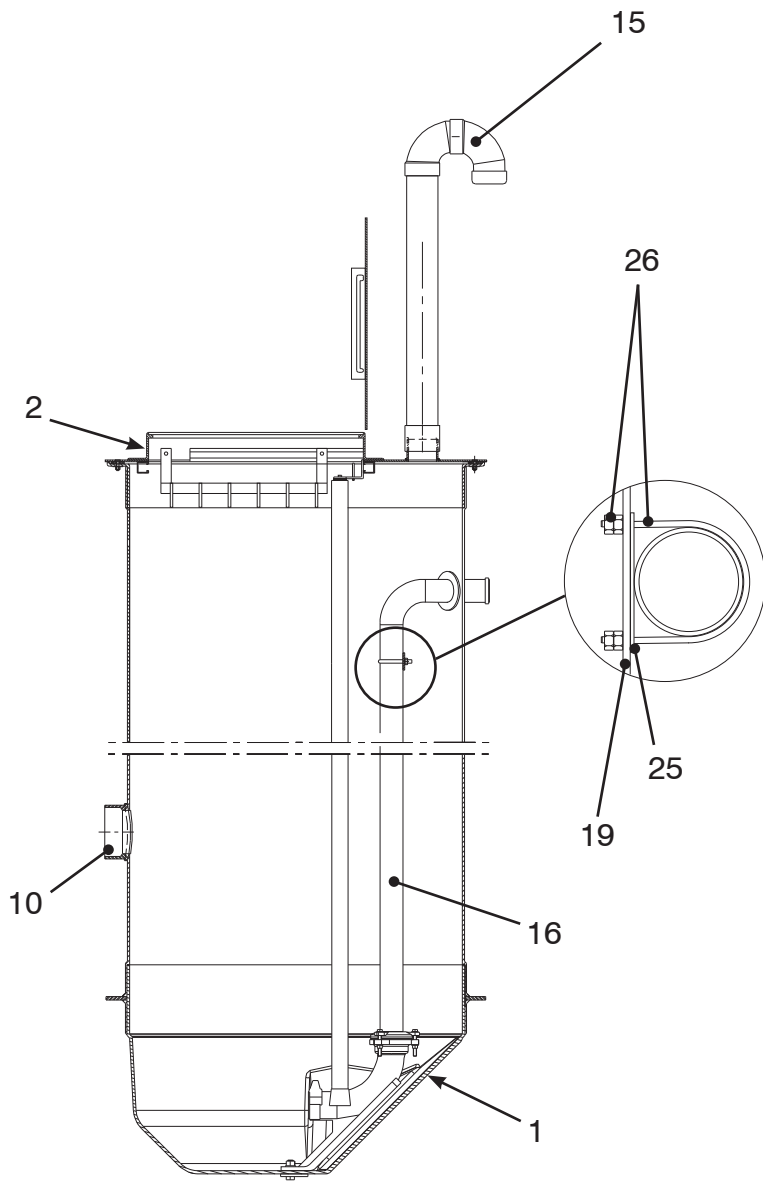

| TOP 4 (3" Piping) | | | | |
|-------------------|--|------------------|-----------------------|--------|
| Item No. | Description | Material | Part Number | Qty |
| 1 | 4' Basin/Cylinder/Assembly, w/ anti-flotation flange | Fiberglass | | 1 |
| 2 | 4' Cover, w/Safe-Hatch | Aluminum | | 1 |
| | Cover w/1 Vent | | FBC-29.75X38AOSH-48-1 | |
| | Cover w/ 2 Vent | | FBC-29.75X38AOSH-48-2 | |
| 3 | Screw, flathead, 82°, 3/8"-16 x 1 1/2" | Stainless Steel | | 6 |
| 4 | Nut, 3/8"-16 | Stainless Steel | | 6 |
| 5 | Washer, 3/8" ID, 1 1/2" OD, 5/16" thick | Stainless Steel | | 6 |
| 6 | Cover Spacer 1 7/8" OD x 1/2"ID x 5/16" thk. | PE | | 6 |
| 7 | 3" Flexible boot (discharge piping) | Rubber | FEB-6300 | 2 |
| 10 | Inlet wall penetrations | | | |
| | 4" Flexible boot (inlet piping) | Rubber | FEB-7400 | 1 |
| | 6" Flexible boot (inlet piping) | Rubber | FEB-8600 | 1 |
| | 4" Cast iron caulking hub (inlet piping) | Cast Iron | | 1 |
| | 6" Cast iron caulking hub (inlet piping) | Cast Iron | | 1 |
| | 8" Cast iron caulking hub (inlet piping) | Cast Iron | | 1 |
| 11 | Cable hanger w/ 6 Hooks | 316 SS | F-CH-316SS-HD | 1 |
| 12 | 2" guide bars | 316 SS | | |
| | 2" 316 SS guide bars | 316 SS | | Varies |
| | 2" Galvanized guide bars | Galvanized Steel | | Varies |
| 13 | 2" Upper guide bar brackets | 316 SS | 613 68 04 | 2 |
| 14 | Guide bar bracket mounting hardware | SS | 14-590000 | 3 |
| 15 | 4" PVC vent | PVC | | 1 or 2 |
| 16 | Piping | | | |
| | PVC | | | |
| | 3" PVC sch 80 socket weld piping | PVC | P80PM | Varies |
| | 3" PVC sch 80 90 degree socket weld elbow | PVC | P80S9M | 2 |
| | Ductile Iron | | | |
| | 3" ductile iron piping flanged one-end | Ductile Iron | | Varies |
| | 3" ductile iron 90 degree flanged elbow | Ductile Iron | | 2 |
| | 3" flange bolts 5/8" (11) x 2-1/2" Hex Head Bolt | 316 SS | | 16 |
| | 3" flange nuts 5/8" (11) Nut | 316 SS | | 16 |
| | 3" flange washers 21/32" ID x 1-5/16" OD Washer | 316 SS | | 32 |
| | 3" flange gasket, 1/8" thick | Rubber (Buna -N) | | 4 |
| | Stainless Steel | | | |
| | 3" 316 SS sch 10 butt weld piping | 316 SS | | Varies |
| | 3" 316 SS sch 10 90 degree butt weld elbow | 316 SS | | 2 |
| 17 | 3" discharge connection, left | Cast Iron | 620 00 10 | 1 |
| 18 | 3" discharge connection, right | Cast Iron | 619 99 10 | 1 |
| 19 | Pipe support | | | |
| | for PVC & Stainless Steel | | | |
| | 4' station - 3" PVC/SS pipe support | 316 SS | | 1 or 2 |

| TOP 4 (3" Piping) | | | | |
|-------------------|---|----------|-----------------------|--------|
| Item No. | Description | Material | Part Number | Qty |
| | for Ductile Iron | | | |
| | 4' station - 3" ductile iron pipe support | 316 SS | | 1 or 2 |
| 23 | Discharge connection nuts - 3/4"-10 | 316 SS | | 8 |
| 24 | Discharge connection washers - 3/4" | 316 SS | | 8 |
| 25 | Pipe support spacers (PVC and Stainless Steel piping only): | NDPE | | |
| 26 | U-bolts | 316 SS | | |
| | PVC & Stainless Steel | | | |
| | for 3" pipe, 3-5/8" O.D. pipe, 3/8"-16 | 316 SS | McMaster Carr 29605t8 | 2 |
| | Ductile Iron | | | |
| | for 3" pipe, 4-1/8" O.D. pipe, 3/8"-16 | 316 SS | McMaster Carr 59605T9 | 2 |
| 31 | 3" NPT threaded plastic coupling (power cables) | Plastic | | 1 |
| 32 | 1 1/4" NPT threaded plastic coupling(float switches) | Plastic | 1860SCF125P | 1 |

| TOP 5 (3" Piping) | | | | |
|-------------------|--|------------------|--------------------|--------|
| Item No. | Description | Material | Part Number | Qty |
| 1 | 5' Basin/Cylinder/Assembly, w/ anti-flotation flange | Fiberglass | | 1 |
| 2 | 5' Cover, w/Safe-Hatch | Aluminum | | 1 |
| | Cover w/ 1 Vent | | FBC-31X42AOSH-60-1 | |
| | Cover w/ 2 Vent | | FBC-31X42AOSH-60-2 | |
| 3 | Screw, flathead, 82°, 3/8"-16 x 1 1/2" | 316 SS | | 8 |
| 4 | Nut, 3/8"-16 | 316 SS | | 8 |
| 5 | Washer, 13/32" ID, 1 1/2" OD, 1/16" thick, pe | 316 SS | | 8 |
| 6 | Cover spacer 1 7/8" OD x 1/2" ID x 5/16" thick. | PE | | 8 |
| 7 | 3" Flexible boot (discharge piping) | Rubber | FEB-6300 | |
| 10 | Inlet wall penetrations | | | |
| | 4" Flexible boot (inlet piping) | Rubber | FEB-6300 | 1 |
| | 6" Flexible boot (inlet piping) | Rubber | FEB-7400 | 1 |
| | 4" Cast iron caulking hub (inlet piping) | Cast Iron | CIH4x3660 | 1 |
| | 6" Cast iron caulking hub (inlet piping) | Cast Iron | CIH6x3660 | 1 |
| | 8" Cast iron caulking hub (inlet piping) | Cast Iron | CIH8x3660 | 1 |
| 11 | Cable hanger w/ 6 Hooks | 316 SS | F-CH-316SS-HD | 1 |
| 12 | 2" guide bars | | | |
| | 2" 316 SS guide bars | 316 SS | | Varies |
| | 2" Galvanized guide bars | Galvanized Steel | | Varies |
| 13 | 2" Upper guide bar brackets | 316 SS | 613 68 04 | 2 |
| 14 | Guide bar bracket, mounting hardware | SS | 14-590000 | 3 |
| 15 | 4" PVC vent | PVC | | 1 or 2 |
| 16 | Piping | | | |
| | PVC | | | |
| | 3" PVC sch 80 socket weld piping | PVC | P80PM | Varies |
| | 3" PVC sch 80 90 degree socket weld elbow | PVC | P80S9M | 2 |
| | Ductile Iron | | | |
| | 3" ductile iron piping flanged one-end | Ductile Iron | SP-DDIPFM | Varies |
| | 3" ductile iron 90 degree flanged elbow | Ductile Iron | DF9M | 2 |
| | 3" flange bolts 5/8" (11) x 2-1/2" Hex Head Bolt | 316 SS | | 16 |
| | 3" flange nuts 5/8" (11) Nut | 316 SS | | 16 |
| | 3" flange washers 21/32" ID x 1-5/16" OD Washer | 316 SS | | 32 |
| | 3" flange gasket, 1/8" thick | Rubber (Buna -N) | | 4 |
| | Stainless Steel | | | |
| | 3" 316 SS sch 10 butt weld piping | 316 SS | | Varies |
| | 3" 316 SS sch 10 90 degree butt weld elbow | 316 SS | | 2 |
| 17 | 3" discharge connection, left | Cast Iron | 620 00 10 | 1 |
| 18 | 3" discharge connection, right | Cast Iron | 619 99 10 | 1 |
| 19 | Pipe support | | | |
| | for PVC & Stainless Steel | | | |
| | 5' station - 3" PVC/SS pipe support | 316 SS | | 1 or 2 |
| | for Ductile Iron | | | |

| TOP 5 (3" Piping) | | | | |
|--------------------------|--|-----------------|--------------------|------------|
| Item No. | Description | Material | Part Number | Qty |
| | 5' station - 3" ductile iron pipe support includes: | 316 SS | | 1 or 2 |
| 23 | Discharge connection nuts - 3/4"-10 | 316 SS | | 8 |
| 24 | Discharge connection washers - 3/4" | 316 SS | | 8 |
| 25 | Pipe support spacers, PVC and Stainless Steel piping only) | | 14-68 21 66 | 2 |
| 26 | U-bolts | 316 SS | | |
| | PVC & Stainless Steel | | | |
| | for 3" pipe, 3-5/8 O.D. pipe, 3/8"-16 | 316 SS | MCASTER 29605t8 | 2 |
| | Ducticle Iron | | | |
| | for 3" pipe, 4-1/8" O.D. pipe, 3/8"-16 | 316 SS | MCASTER 59605T9 | 2 |
| 31 | 3" NPT threaded plastic coupling (power cables) | Plastic | | 1 |
| 32 | 1 1/4" NPT threaded plastic coupling(float switches) | Plastic | 1860SCF125P | 1 |

| TOP 5 (4" Piping) | | | | |
|-------------------|--|------------------|--------------------|--------|
| Item No. | Description | Material | Part Number | Qty |
| 1 | 5' Basin/Cylinder/Assembly, w/ anti-flotation flange | Fiberglass | | 1 |
| 2 | 5' Cover, w/Safe-Hatch | Aluminum | | 1 |
| | Cover w/ 1 Vent | | FBC-31X42AOSH-60-1 | |
| | Cover w/ 2 Vent | | FBC-31X42AOSH-60-2 | |
| 3 | Screw, flathead, 82", 3/8"-16 x 1 1/2" | 316 SS | | 8 |
| 4 | Nut, 3/8-16 | 316 SS | | 8 |
| 5 | Washer, 13/32" ID, 1 1/2" OD, 1/16" thick | 316 SS | | 8 |
| 6 | Cover spacer 1 7/8" OD x 1/2" ID x 5/16" thick. | PE | | 8 |
| 7 | 4" Flexible boot (discharge piping) | Rubber | FEB-7400 | |
| 10 | Inlet wall penetrations | | | |
| | 4" Flexible boot (inlet piping) | Rubber | FEB-8600 | 1 |
| | 6" Flexible boot (inlet piping) | Rubber | FEB-7400 | 1 |
| | 4" Cast iron caulking hub (inlet piping) | Cast Iron | CIH4x3660 | 1 |
| | 6" Cast iron caulking hub (inlet piping) | Cast Iron | CIH6x3660 | 1 |
| | 8" Cast iron caulking hub (inlet piping) | Cast Iron | CIH8x3660 | 1 |
| 11 | Cable hanger w/ 6 Hooks | 316 SS | F-CH-316SS-HD | 1 |
| 12 | 2" guide bars | | | |
| | 2" 316 SS guide bars | 316 SS | | Varies |
| | 2" Galvanized guide bars | Galvanized Steel | | Varies |
| 13 | 2" Upper guide bar brackets | 316 SS | 613 68 04 | 2 |
| 14 | Guide bark bracket, mounting hardware | SS | 14-590000 | 3 |
| 15 | 4" PVC vent | PVC | | 1 or 2 |
| 16 | Piping | | | |
| | PVC | | | |
| | 4" PVC sch 80 socket weld piping | PVC | P80PP | Varies |
| | 4" PVC sch 80 90 degree socket weld elbow | PVC | P80S9P | 2 |
| | Ductile Iron | | | |
| | 4" ductile iron piping flanged one-end | Ductile Iron | SP-DPDIFP7 | Varies |
| | 4" ductile iron 90 degree flanged elbow | Ductile Iron | DF9P | 2 |
| | 4" flange bolts 5/8" (11) x 3" Hex Head Bolt | 316 SS | | 32 |
| | 4" flange nuts 5/8" (11) Nut | 316 SS | | 32 |
| | 4" flange washers 21/32" ID x 1-5/16" OD Washer | 316 SS | | 64 |
| | 4" flange gasket, 1/8" thick | Rubber (Buna -N) | | 4 |
| | Stainless Steel | | | |
| | 4" 316 SS sch 10 butt weld piping | 316 SS | | Varies |
| | 4" 316 SS sch 10 90 degree butt weld elbow | 316 SS | | 2 |
| 17 | 4" discharge connection, left | Cast Iron | 620 02 10 | 1 |
| 18 | 4" discharge connection, right | Cast Iron | 620 01 10 | 1 |
| 19 | Pipe support | | | |
| | for PVC & Stainless Steel | | | |
| | 5' station - 4" PVC/SS pipe support | 316 SS | | 1 or 2 |
| | for Ductile Iron | | | |

| TOP 5 (4" Piping) | | | | |
|--------------------------|--|-----------------|--------------------|------------|
| Item No. | Description | Material | Part Number | Qty |
| | 5' station - 4" ductile iron pipe support includes: | 316 SS | | 1 or 2 |
| 23 | Discharge connection nuts - 3/4"-10 | 316 SS | | 8 |
| 24 | Discharge connection washers - 3/4" | 316 SS | | 8 |
| 25 | Pipe support spacers, PVC and Stainless Steel only | NDPE | | 2 |
| 26 | U-bolts | 316 SS | | |
| | PVC & Stainless Steel | | | |
| | for 4" pipe, 4-5/8" O.D. pipe, 3/8"-16 | 316 SS | MCASTER 29605T11 | 2 |
| | Ducticle Iron | | | |
| | for 4" pipe, 5" O.D. pipe, 3/8"-16 | 316 SS | | 2 |
| 31 | 3" NPT threaded plastic coupling (power cables) | Plastic | | 1 |
| 32 | 1 1/4" NPT threaded plastic coupling(float switches) | Plastic | 1860SCF125P | 1 |

| TOP 6 (4" Piping) | | | | |
|-------------------|--|------------------|-----------------------|--------|
| Item No. | Description | Material | Part Number | Qty |
| 1 | 6' Basin/Cylinder/Assembly, w/ anti-flotation flange | Fiberglass | | 1 |
| 2 | 6' Cover, w/Safe-Hatchr | Aluminum | | 1 |
| | Cover w/ 1 Vent | | FBC-33.75X51AOSH-72-1 | |
| | Cover w/ 2 Vent | | FBC-33.75X51AOSH-72-2 | |
| 3 | Screw, flathead, 82", 3/8"-16 x 1 1/2" | 316 SS | | 8 |
| 4 | Nut, 3/8"-16 | 316 SS | | 8 |
| 5 | Washer, 13/32" ID, 1 1/2" OD, 1/16" thick | 316 SS | | 8 |
| 6 | Cover spacer 1 7/8" OD x 1/2" ID x 5/16" thick. | PE | | 8 |
| 7 | 4" Flexible boot (discharge piping) | Rubber | FEB-7400 | 2 |
| 10 | Inlet wall penetrations | | | |
| | 6" Flexible boot (inlet piping) | Rubber | FEB-8600 | 1 |
| | 6" Cast iron caulking hub (inlet piping) | Cast Iron | CIH6x3660 | 1 |
| | 8" Cast iron caulking hub (inlet piping) | Cast Iron | CIH8x3660 | 1 |
| 11 | Cable hanger w/ 6 Hooks | 316 SS | F-CH-316SS-HD | 1 |
| 12 | 2" guide bars | | | |
| | 2" 316 SS guide bars | 316 SS | | Varies |
| | 2" Galvanized guide bars | Galvanized Steel | | Varies |
| 13 | 2" Upper guide bar brackets | 316 SS | 613 68 04 | 2 |
| 14 | Mounting hardware for guide bar | SS | 14-590000 | 3 |
| 15 | 4" PVC vent | PVC | | 1 or 2 |
| 16 | Piping | | | |
| | PVC | | | |
| | 4" PVC sch 80 socket weld piping | PVC | P80PP | Varies |
| | 4" PVC sch 80 90 degree socket weld elbow | PVC | P80S9P | 2 |
| | Ductile Iron | | | |
| | 4" ductile iron piping flanged one-end | Ductile Iron | SP-DPDIFP7 | Varies |
| | 4" ductile iron 90 degree flanged elbow | Ductile Iron | DF9P | 2 |
| | 4" flange bolts 5/8" (11) x 3" Hex Head Bolt | 316 SS | | 32 |
| | 4" flange nuts 5/8" (11) Nut | 316 SS | | 32 |
| | 4" flange washers 21/32" ID x 1-5/16" OD Washer | 316 SS | | 64 |
| | 4" flange gasket, 1/8" thick | Rubber (Buna -N) | | 4 |
| | Stainless Steel | | | |
| | 4" 316 SS sch 10 butt weld piping | 316 SS | | Varies |
| | 4" 316 SS sch 10 90 degree butt weld elbow | 316 SS | | 2 |
| 17 | 4" discharge connection, left | Cast Iron | 620 02 10 | 1 |
| 18 | 4" discharge connection, right | Cast Iron | 620 01 10 | 1 |
| 19 | Pipe support | | | |
| | for PVC & Stainless Steel | | | |
| | 6' station - 4" PVC/SS pipe support | 316 SS | | 1 or 2 |

| TOP 6 (4" Piping) | | | | |
|--------------------------|--|-----------------|--------------------|------------|
| Item No. | Description | Material | Part Number | Qty |
| | for Ductile Iron | | | |
| | 6' station - 4" ductile iron pipe support | 316 SS | | 1 or 2 |
| 23 | Discharge connection nuts - 3/4"-10 | 316 SS | | 8 |
| 24 | Discharge connection washers - 3/4" | 316 SS | | 8 |
| 25 | Pipe support spacers, PVC and Stainless Steel only | NDPE | 14-68 21 66 | 2 |
| 26 | U-bolts | 316 SS | | |
| | PVC & Stainless Steel | | | |
| | for 4" pipe, 4-5/8" O.D. pipe, 3/8"-16 | 316 SS | MCASTER 29605T11 | 2 |
| | Ducticle Iron | | | |
| | for 4" pipe, 5" O.D. pipe, 3/8-16 | 316 SS | | 2 |
| 31 | 3" NPT threaded plastic coupling (power cables) | Plastic | | 1 |
| 32 | 1 1/4" NPT threaded plastic coupling(float switches) | Plastic | 1860SCF125P | 1 |

| TOP 6 (6" Piping) | | | | |
|-------------------|--|------------------|-----------------------|--------|
| Item No. | Description | Material | Part Number | Qty |
| 1 | 6' Basin/Cylinder/Assembly, w/ anti-flotation flange | Fiberglass | | 1 |
| 2 | 6' Cover, w/Safte-Hatchr | Aluminum | | 1 |
| | Cover w/ 1 Vent | | FBC-33.75X51AOSH-72-1 | |
| | Cover w/ 2 Vent | | FBC-33.75X51AOSH-72-2 | |
| 3 | Screw, flathead, 82°, 3/8"-16 x 1 1/2" | 316 SS | | 8 |
| 4 | Nut, 3/8"-16 | 316 SS | | 8 |
| 5 | Washer, 13/32" ID, 1 1/2" OD, 1/16" thick | 316 SS | | 8 |
| 6 | Cover spacer 1 7/8" OD x 1/2" ID x 5/16" thick. | PE | | 8 |
| 7 | 6" Flexible boot (discharge piping) | Rubber | FEB-8600 | 2 |
| 10 | Inlet wall penetrations | | | |
| | 6" Flexible boot (inlet piping) | Rubber | FEB-8600 | 1 |
| | 6" Cast iron caulking hub (inlet piping) | Cast Iron | CIH6x3660 | 1 |
| | 8" Cast iron caulking hub (inlet piping) | Cast Iron | CIH8x3660 | 1 |
| 11 | Cable hanger w/ 6 Hooks | 316 SS | F-CH-316SS-HD | 1 |
| 12 | 2" guide bars | | | |
| | 2" 316 SS guide bars | 316 SS | | Varies |
| | 2" Galvanized guide bars | Galvanized Steel | | Varies |
| 13 | 2" Upper guide bar brackets | 316 SS | 613 68 04 | 2 |
| 14 | Guide bar bracket, mounting hardware | SS | 14-590000 | 3 |
| 15 | 4" PVC vent | PVC | | 1 or 2 |
| 16 | Piping | | | |
| | PVC | | | |
| | 6" PVC sch 80 socket weld piping | PVC | P80PU | Varies |
| | 6" PVC sch 80 90 degree socket weld elbow | PVC | P8069U | 2 |
| | 6" PVC sch 80 45 degree socket weld elbow | | P80S4U | 2 |
| | Ductile Iron | | | |
| | 6" ductile iron plain-end piping | Ductile Iron | | Varies |
| | 6" ductile iron 22.5 degree mechanical joint x mechanical joint elbow | Ductile Iron | | 2 |
| | 6" ductile iron 90 degree mechanical joint x mechanical joint elbow | Ductile Iron | MJ9LAU | 2 |
| | Stainless Steel | | | |
| | 6" 316 SS sch 10 butt weld piping | 316 SS | | Varies |
| | 6" 316 SS sch 10 90 degree butt weld elbow | 316 SS | | 2 |
| | 6" 316 SS sch 10 45 degree butt weld elbow | 316 SS | | 2 |
| | 6" Mechanical joint fjield locking accessory kit (includes tee bolts, nuts, gasket and gland | | MJFLAKDIU | 8 |
| 17 | 6" discharge connection, left | Cast Iron | 620 04 10 | 1 |
| 18 | 6" discharge connection, right | Cast Iron | 620 03 10 | 1 |

| TOP 6 (6" Piping) | | | | |
|-------------------|--|----------|-------------|--------|
| Item No. | Description | Material | Part Number | Qty |
| 19 | Pipe support | | | |
| | for PVC & Stainless Steel | | | |
| | 6' station - 6" PVC/SS pipe support | 316 SS | | 1 or 2 |
| | for Ductile Iron | | | |
| | 6' station - 6" ductile iron pipe support | 316 SS | | 1 or 2 |
| 23 | Discharge connection nuts - 3/4"-10 | 316 SS | | 8 |
| 24 | Discharge connection washers - 3/4" | 316 SS | | 8 |
| 25 | Pipe support spacers, for PVC and Stainless Steel only | NDPE | | 2 |
| 26 | U-bolts | 316 SS | | |
| | PVC & Stainless Steel | | | |
| | for 6" pipe, 6-5/8" O.D. pipe, 1/2"-13 | 316 SS | | 2 |
| | Ducticle Iron | | | |
| | for 6" pipe, 7" O.D. pipe, 1/2-13 | 316 SS | | 2 |
| 31 | 3" NPT threaded plastic coupling (power cables) | Plastic | | 1 |
| 32 | 1 1/4" NPT threaded plastic coupling(float switches) | Plastic | 1860SCF125P | 1 |

ITT Flygt Corporation
(United States)

35 Nutmeg Drive, P.O. Box 1004, Trumbull, Connecticut 06611-0943 • Tel. (203) 380-4700 • Fax (203) 380-4705
www.flygtus.com

Branch Offices

CALIFORNIA

790-A Chadbourne Road, Fairfield, California. 94534-9643 • Tel. (707) 422-9894 • Fax (707) 422-9808
(Los Angeles) 3951 Capitol Avenue, City of Industry, California 90601 • Tel. (562) 908-1200 • Fax 562-908-1211

FLORIDA

2152 Sprint Boulevard, Apopka, FL 32703 • Tel. (407) 880-2900 • Fax: 407-880-2962
5771 Country Lakes Drive, Ft. Myers, FL 33905 • Tel. (239) 693-5226 • Fax (239) 693-1485
1730 Tenth Street W, Riviera Beach, FL 33404 • Tel. (561) 848-1200 • Fax 561-848-1299

GEORGIA

124 Airport Park Drive, Garden City, Georgia 31408 • Tel. (912) 966-1577 • Fax 912-966-1579
90 Horizon Drive, Suwanee, Georgia 30024 • Tel. (770) 932-4320 • Fax (770) 932-4321

ILLINOIS

8402 West 183rd Street, Suite A, Tinley Park, Illinois 60487 • Tel. (708) 342-0484 • Fax (708) 342-0491

MASSACHUSETTS

78K Olympia Avenue, Woburn, Massachusetts 01801 • Tel. (781) 935-6516 • Fax (781) 938-0364

NEW YORK

600 Mile Crossing Boulevard, Suite 3, Rochester, New York 14624 • Tel. (585) 426-0280 • Fax (585) 426-3947

NORTH CAROLINA

511 Eagleton Downs Drive, Pineville, North Carolina 28134 • Tel. (704) 504-8804 • Fax (704) 504-8773

OHIO

501 Technecenter Dr Ste C, Milford, OH 45150 • Tel. (513) 831-7867 • Fax (513) 831-7868
700 Lake View Drive, Monroe, Ohio 45050 • Tel. (513) 539-9106 • Fax (513) 539-9124

OREGON

2630 North Marine Drive, Portland, Oregon 97217 • Tel. (503) 240-1980 • Fax (503) 240-3445

PENNSYLVANIA

2330 Yellow Springs Road, Malvern, Pennsylvania 19355 • Tel. (610) 647-6620 • Fax (610) 647-5563

TEXAS

2400 Tarpley Road, Carrollton, Texas 75006-2407 • Tel. (972) 418-2400 • Fax (972) 416-9570
1959 Saratoga Boulevard, Bldg 29, Corpus Christi, Texas 78417 • Tel. (361) 808-7867 • Fax (361) 225-2965
204 Industrial Boulevard, Cedar Park, Texas 78613 • Tel. (512) 260-0281 • Fax (512) 260-0286
San Antonio, Texas • Tel. (210) 287-2222 • Fax (361) 225-2965

WISCONSIN

N27 W23291 Roundy Drive, Pewaukee, Wisconsin 53072 • Tel. (262) 544-1922 • Fax (262) 544-1399

ITT Flygt Canada
(Canada)

300 ave. Labrosse, Pointe-Claire, Québec H9R 4V5 • Tel. (514) 695-0133 • Fax (514) 695-7990
www.ittflygt.ca

Sales Locations

ALBERTA

6704 30th Street S.E., Calgary, Alberta T2C 1N9 • Tel. (403) 279-8371 • Fax (403) 279-0948
10554 169th Street, Edmonton, Alberta T5P 3X6 • Tel. (780) 489-1961 • Fax (780) 486-5530

BRITISH COLUMBIA

74, Glacier Street, Coquitlam, British Columbia V3K 5Y9 • Tel. (604) 941-6664 • Fax (604) 941-3659

MANITOBA

55 Terracon Place, Winnipeg, Manitoba R2J 4B3 • Tel. (204) 235-0050 • Fax (204) 235-0066

NEW BRUNSWICK

189 Collishaw Street, Moncton, New Brunswick E1C 9P8 • Tel. (506) 857-2244 • Fax (506) 859-8612

NOVA SCOTIA

15 McQuade Lake Crescent, Bayers Lake Industrial Park, Halifax, Nova Scotia B3S 1C4 • Tel. (902) 450-1177 • Fax (902) 450-1170

ONTARIO

111 Romina Drive, Concord Ontario L4K 4Z9 • Tel. (905) 760-7530 • Fax (905) 760-7527
21 Bentley Avenue, Ottawa, Ontario K2E 6T7 • Tel. (613) 225-9600 • Fax (613) 225-5496
1086 Elisabetha Road, Sudbury, Ontario P3A 4R7 • Tel. (705) 560-2141 • Fax (705) 560-8260
105, North May Street, Suite 214, Thunder Bay, Ontario P7C 3N9 • Tel. (807) 625-9960 • Fax (807) 625-9970

QUÉBEC

1070 rue de l'Écho, Val d'Or, Québec J9P 6X8 • Tel. (819) 825-0792 - Fax (819) 825-5677
609 rue Adanac, Québec, Québec G1C 7G6 • Tel. (418) 667-1694 • Fax(418) 666-9593

SASKATCHEWAN

Bay 10, 3111 Millar Avenue, Saskatoon, Saskatchewan S7K 6N3 • Tel. (306) 933-4849 • Fax (306) 931-0051

ACO StormBrixx stormwater attenuation and infiltration range

ACO StormBrixx is a unique and patented plastic geocellular stormwater management system. Its versatile design allows the system to be used in applications across all construction environments as a standalone solution or as part of an integrated sustainable urban drainage (SuDS) scheme.

The patented brickbonding and cross bonding feature provides a strong, long term installation and also helps to improve the construction speed of the tank.

ACO StormBrixx simplifies delivery, site logistics and installation as a result of its stackable design. For each delivery of StormBrixx, up to 4 loads of competitor product may be required, making StormBrixx approximately 75% more efficient in delivery.

ACO StormBrixx addresses the fundamental requirement of access and maintenance for SuDS Approval Boards (SABS) and water companies. The open cell structure permits completely free access for CCTV and jetting equipment which allows the whole system, including all the extremities, to be inspected and maintained from just a few access points.

The range consists of ACO StormBrixx HD (Heavy-duty) which has a depth to invert of up to 6.0m and includes man access and 3D inspection access units, plus the new ACO StormBrixx SD (Standard-duty) which has a depth to invert of up to 4.5m and includes access plates to allow easy access for CCTV and jetting equipment.



StormBrixx HD



StormBrixx SD

KEY BENEFITS

- Allows **three dimensional unrestricted flow** of water
- **High void ratio** minimises excavation volume
- **Brick bonded** and **cross bonding** for optimum stability
- **Stackable 'nested' design** improves build efficiency through dramatically simplified delivery, on site storage and handling during installation
- **Fully certified performance**
- **Man access** and 3D inspection access to tank interior (HD)
- **Low flow, drain down** and **silt management** facility
- Manufactured from **recyclable polypropylene**
- **50/60 year design life**

STRUCTURAL INTEGRITY

The patented brickbonding and cross bonding feature enables strong, long term installation and improved construction speed of the tank.

SIMPLIFIED HANDLING AND LOGISTICS

Each single injection moulded body nestles optimising logistical and installation costs, thus helping to reduce carbon footprint of the system.

ACCESS AND MAINTENANCE

The whole system, including all the extremities can be inspected and maintained from just a few access points thanks to the open cell structure.



The stackable design reduces transportation costs and improves the carbon footprint of the product

Example:
280m³ storage volume is required for project A. Using ACO StormBrixx the project requirement can be transported on a single vehicle whereas up to four vehicles may be required for other comparable systems.



MAIN COMPONENTS

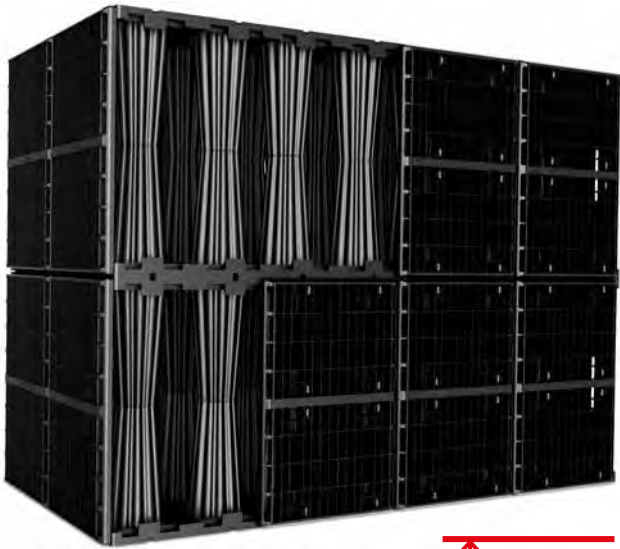

4.5m Max depth to invert

SD

| Technical specification | |
|--|----------------------|
| No. of assembled units per m ³ | 1.52 |
| 1 assembled unit = 2 half bodies (1.2 x 0.6 x 0.914) | |
| Gross storage volume (m ³) | 0.658 |
| Nett storage volume (m ³) | 0.638 |
| Void ratio | 97% |
| Short term vertical compressive strength | 350kN/m ² |
| Short term lateral compressive strength | 70kN/m ² |

Components overview - dimensions and weights

| Product code | Description | Length (mm) | Width (mm) | Height (mm) | Weight (kg) |
|--------------|---------------------|-------------|------------|-------------|-------------|
| 314125 | Half Body | 1200 | 600 | 494 | 9.41 |
| 314126 | Side Panel | 907 | 592 | 104 | 3.13 |
| 314127 | Top Cover | 550 | 550 | 45 | 0.76 |
| 314093 | Connectors | 53.4 | 44.2 | 26.5 | 0.1 |
| 314075 | Remote access plate | 650 | 650 | 120 | 4.74 |



6.0m Max depth to invert

HD

| Technical specification | |
|---|----------------------|
| No. of assembled units per m ³ | 2.28 |
| 1 assembled unit = 2 half bodies (1.2 x 0.6 x 0.61) | |
| Gross storage volume (m ³) | 0.439 |
| Nett storage volume (m ³) | 0.417 |
| Void ratio | 95% |
| Short term vertical compressive strength | 455kN/m ² |
| Short term lateral compressive strength | 95kN/m ² |

Components overview - dimensions and weights

| Product code | Description | Length (mm) | Width (mm) | Height (mm) | Weight (kg) |
|--------------|-------------|-------------|------------|-------------|-------------|
| 314020 | Half Body | 1200 | 600 | 305 | 10 |
| 314021 | Side Panel | 600 | 600 | 55 | 1.6 |
| 314022 | Top Cover | 548 | 548 | 43 | 0.8 |
| 314023 | Connectors | 100 | 40 | 46 | 0.1 |



ACO Pty Ltd
 134-140 Old Bathurst Road, Emu Plains NSW 2750
 Tel: +61 2 4747 4000 Fax: +61 2 4747 4040
 Email: sales@acoaus.com.au Website: www.acoaus.com.au

4. MAINTENANCE

Operation

ACO StormBrixx has been designed to function in conjunction with the engineered drainage system on site. Operations will be driven by naturally occurring systems and will function autonomously. However, upholding a proper schedule of inspection and maintenance is critical to ensure continued functionality and optimum performance of the system.

Inspection

Both ACO StormBrixx and any other stormwater pre-treatment features incorporated must be inspected regularly. Inspection frequency must be determined based on the contributing drainage area, but should never exceed one year between inspections (six months during the first year of operation). Inspections may be required more frequently for pre-treatment systems. Refer to the manufacturer requirements for the proper inspection schedule. Inspection and measurements can be accomplished from the surface without physically entering any confined spaces. If inspection requires confined space entry, all local/regional requirements must be followed.

StormBrixx may incorporate inspection ports, access/maintenance ports, and/or adjoining manholes. Each of these features are easily accessed by removing the cover at the surface. With the cover removed, a visual inspection can be performed to identify sediment deposits within the structure. All access points should be examined to complete a thorough inspection.



ACO StormBrixx Inspection & Maintenance

Maintenance Procedures

It is important to note that failure to control and remove sediment build-up in a sustainable drainage system is the single largest cause of system failure. To ensure effective management of silt in an ACO StormBrixx infiltration system, a sediment forebay can be incorporated. Pretreatment prior to the geocellular tank is recommended.

As sediment has the potential to carry high levels of pollutants, it is important that any sediment removed from the system is disposed of by a licensed contractor in accordance with local regulations.

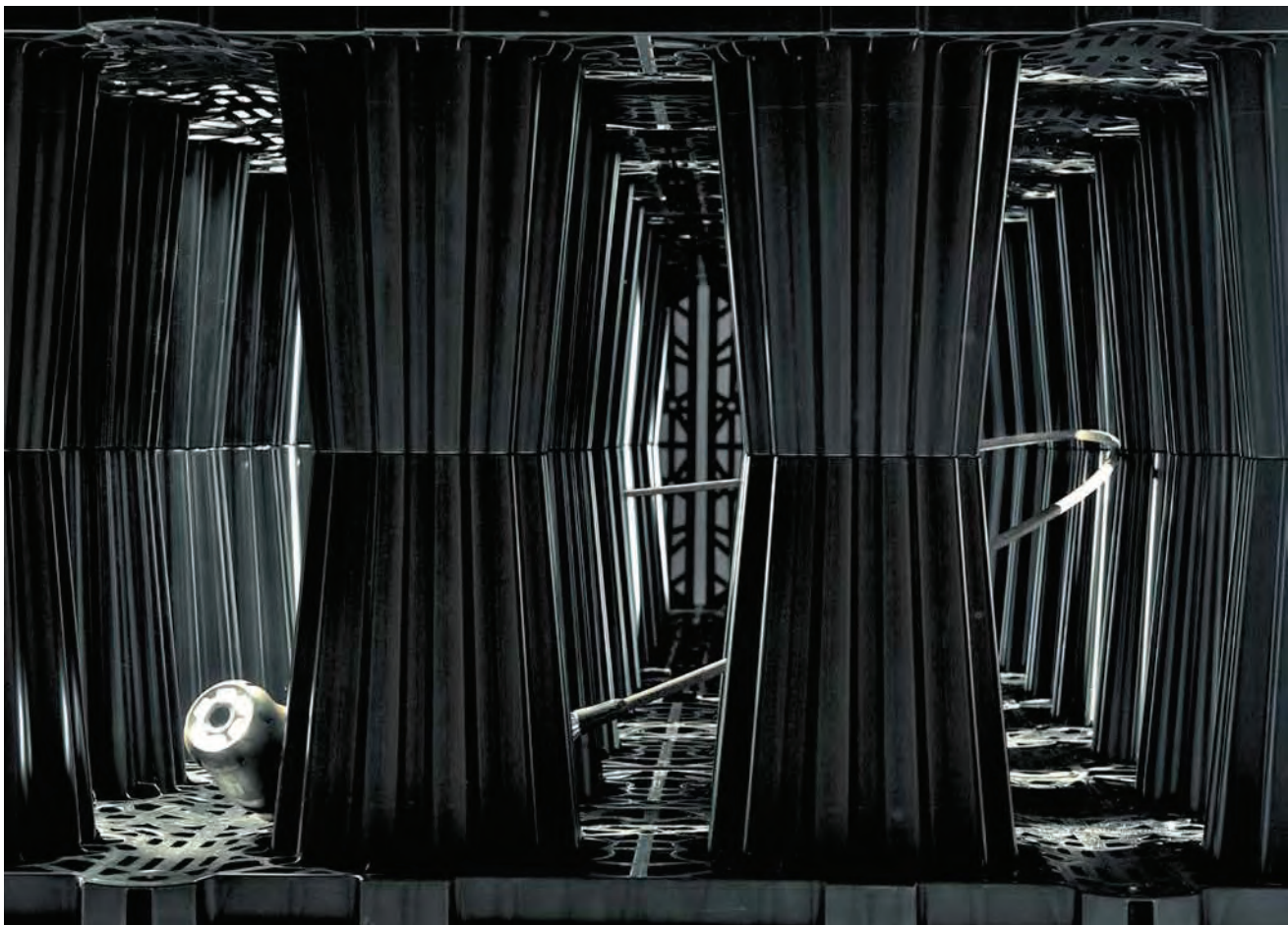



INFILTRATION SYSTEMS

In order to periodically check the effectiveness of the ACO StormBrixx infiltration system, a percolation test can be carried out on the system and compared with the original data. If there is a significant decrease in the infiltration rates, the infiltration system should be filled via the inspection chamber to the invert level of the inlet pipe. It should then be flushed through with water in order to remove sediment and unbind the geotextile.

DETENTION SYSTEMS

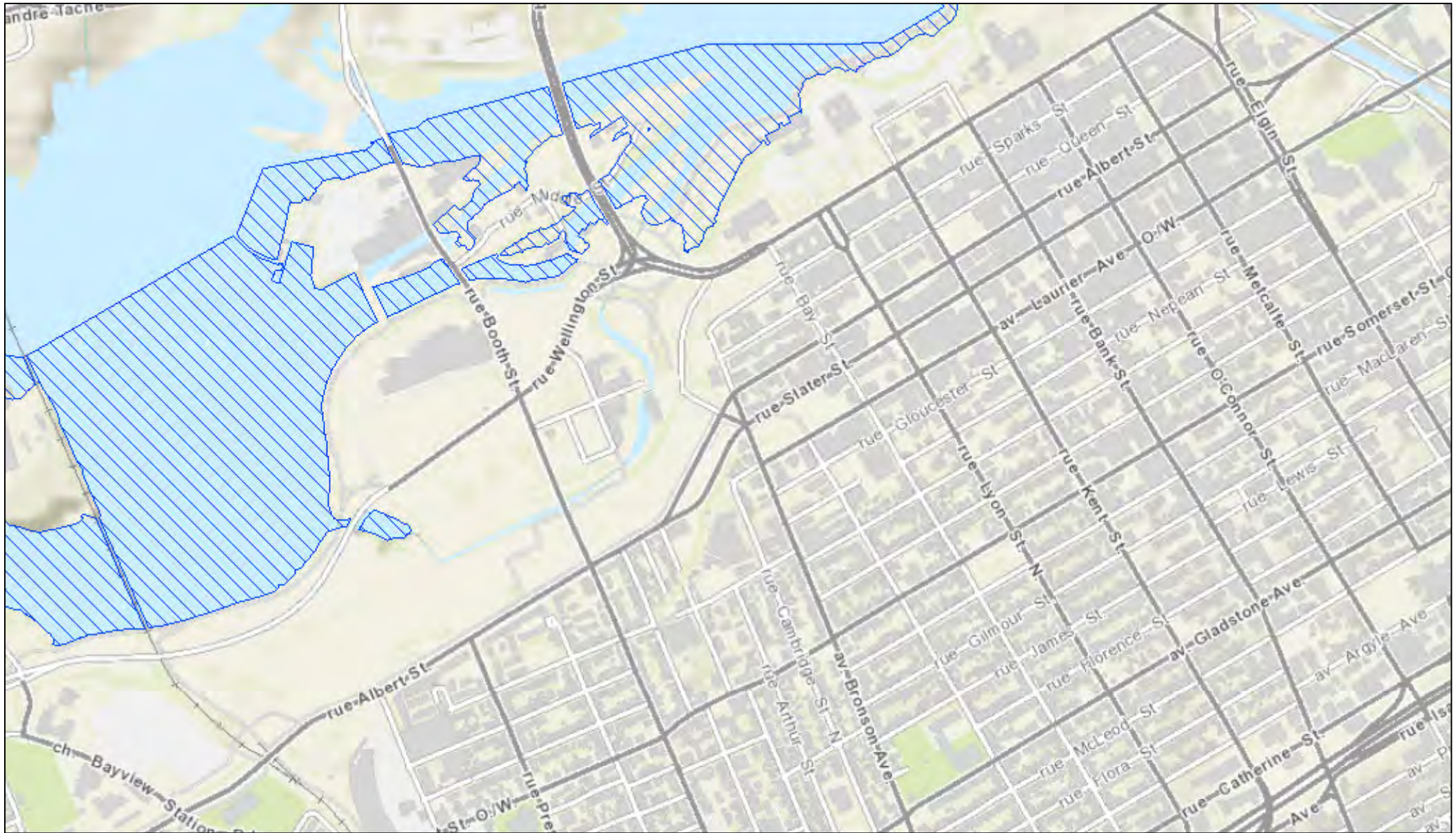

Block the outflow control device—but not the overflow pipe—before filling the detention system to the invert level of the vent pipe. The system should then be filled, then flushed, and the water effluent removed and disposed of by a pumped tanker.

The frequency of the maintenance procedure for ACO StormBrixx systems will be determined by the inspection team. ACO recommends inspections be carried out twice during the first year, yearly after, and after significant storm events. In order to minimize silt build-up, ACO also recommends the use of pretreatment systems upstream of the detention device.



June 5, 2020

Existing Flood Plain Overlay / Zone sous-jacente de plaine inondable actuel

-  Existing Flood Plain Overlay / Zone sous-jacente de plaine inondable actuel
-  Existing Flood Plain Overlay - Area Specific Provisions / Zone sous-jacente de plaine inondable actuel - Dispositions propres à des emplacements

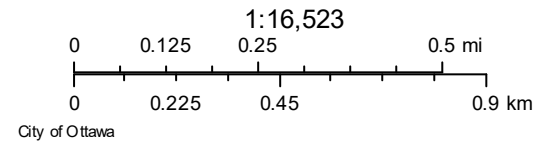

Appendix E

Topographic and Legal Survey

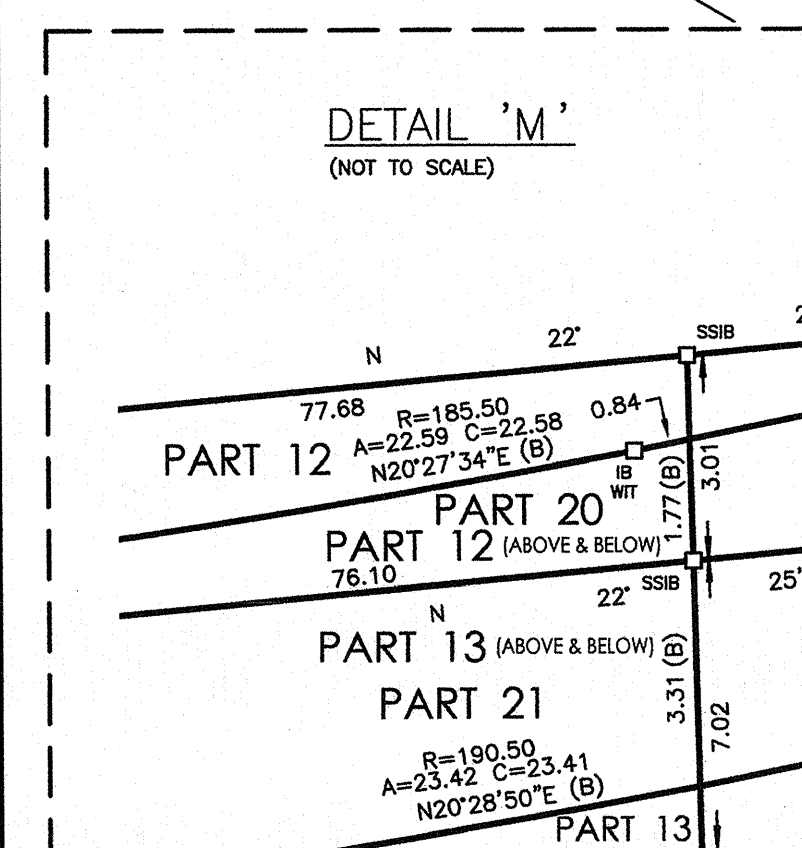
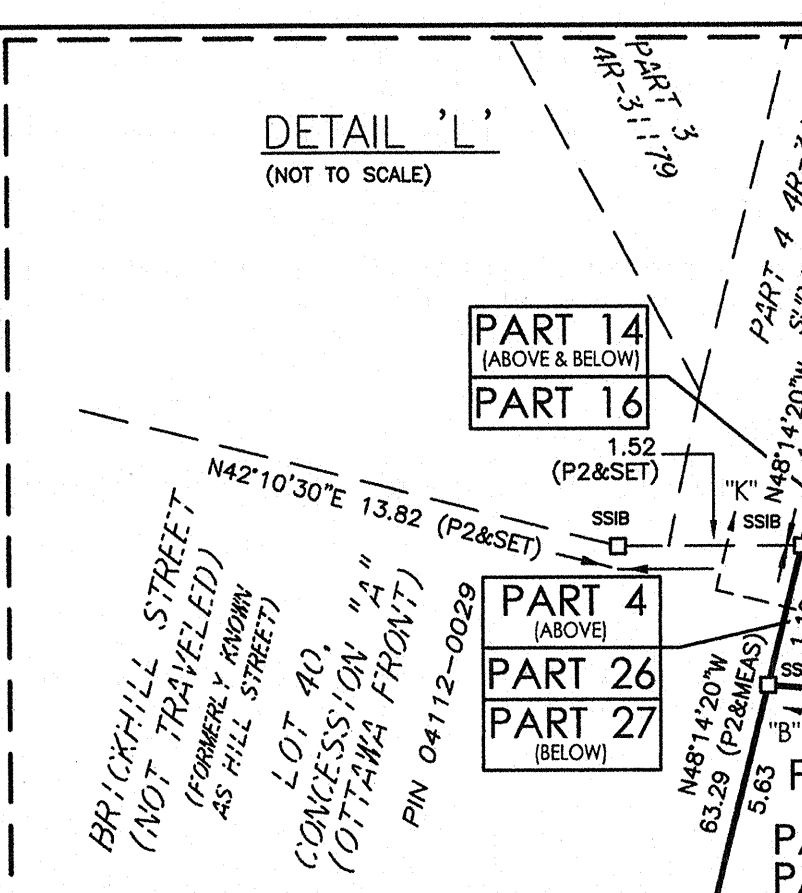
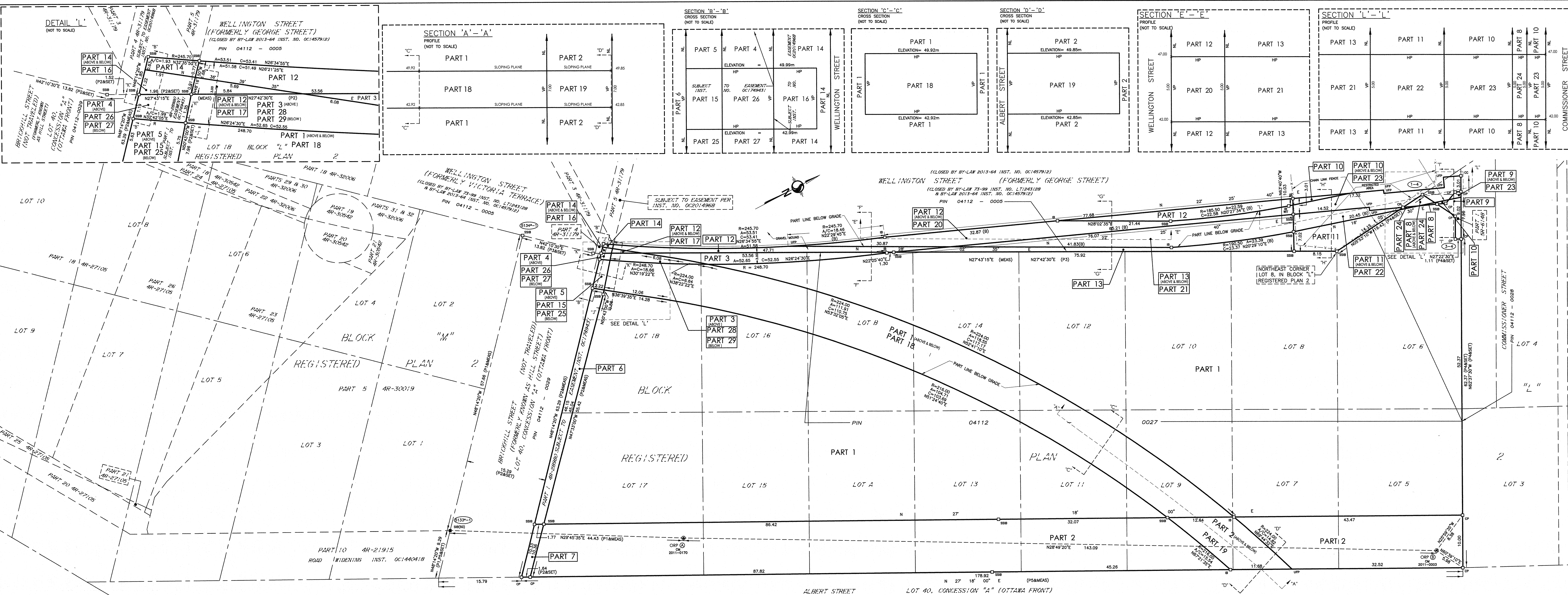

SCHEDULE OF PARTS - PLAN OF SURVEY

| PART | LOT/BLOCK | PLAN/CON. | PIN | AREA |
|------|---|-----------|-----|-----------------------|
| 1 | PART OF LOTS 8 & 10 | | | 8552.4 m ² |
| 2 | PART OF LOTS 8, 9, 10, 11, 12, 13, 14, 15, 16, 17 AND 18 IN BLOCK 'L' | | | 1759.4 m ² |
| 3 | PART OF LOTS 8, 9, 10, 11, 12, 13, 14 AND 17 IN BLOCK 'L' | | | 86.6 m ² |
| 4 | PART OF LOTS 8, 9, 10, 11, 12, 13, 14 AND 17 IN BLOCK 'L' | | | 2.5 m ² |
| 5 | PART OF LOT 18 IN BLOCK 'L' | | | 11.9 m ² |
| 6 | PART OF LOTS 17 AND 18 IN BLOCK 'L' | | | 91.3 m ² |
| 7 | PART OF LOT 17 IN BLOCK 'L' | | | 17.0 m ² |
| 8 | PART OF LOT 6 IN BLOCK 'L' | | | 6.7 m ² |
| 9 | PART OF LOT 6 IN BLOCK 'L' | | | 16.2 m ² |
| 10 | PART OF LOT 6 IN BLOCK 'L' | | | 93.5 m ² |
| 11 | PART OF LOT 18 IN BLOCK 'L' | | | 109.7 m ² |
| 12 | PART OF WELLINGTON STREET (CLOSED BY INST. 5 LT124312B OC1457912) | | | 302.5 m ² |
| 13 | PART OF WELLINGTON STREET (CLOSED BY INST. 5 LT124312B OC1457912) | | | 265.4 m ² |
| 14 | PART OF LOT 18 IN BLOCK 'L' | | | 3.3 m ² |
| 15 | PART OF LOT 18 IN BLOCK 'L' | | | 11.9 m ² |
| 16 | PART OF LOT 18 IN BLOCK 'L' | | | 2.0 m ² |
| 17 | PART OF LOT 18 IN BLOCK 'L' | | | 2.6 m ² |
| 18 | PART OF LOTS 8, 9, 10, 11, 12, 13, 14 AND 18 IN BLOCK 'L' | | | 964.9 m ² |
| 19 | PART OF LOTS 7 AND 9 IN BLOCK 'L' | | | 121.4 m ² |
| 20 | PART OF WELLINGTON STREET (CLOSED BY INST. 3 LT124312B OC1457912) | | | 172.2 m ² |
| 21 | PART OF LOT 6 IN BLOCK 'L' | | | 177.5 m ² |
| 22 | PART OF LOT 6 IN BLOCK 'L' | | | 40.5 m ² |
| 23 | PART OF LOT 6 IN BLOCK 'L' | | | 87.6 m ² |
| 24 | PART OF LOT 6 IN BLOCK 'L' | | | 6.8 m ² |
| 25 | PART OF LOT 6 IN BLOCK 'L' | | | 11.9 m ² |
| 26 | PART OF LOT 18 IN BLOCK 'L' | | | 2.5 m ² |
| 27 | PART OF LOT 18 IN BLOCK 'L' | | | 2.5 m ² |
| 28 | PART OF LOTS 16 AND 18 IN BLOCK 'L' | | | 21.7 m ² |
| 29 | PART OF LOTS 16 AND 18 IN BLOCK 'L' | | | 21.7 m ² |

STRATA PLAN OF SURVEY of
LOTS A, B, 5, 7, 8, 9, 10, 11, 12, 13, 14, 15, 16, 17 AND 18
PART OF LOT 6
IN BLOCK 'L'
PART OF WELLINGTON STREET
 (CLOSED BY INST. 5 LT124312B AND OC1457912)
REGISTERED PLAN 2
CITY OF OTTAWA

METRIC CONVERSION
 DISTANCES AND COORDINATES SHOWN ON THIS PLAN ARE IN METRES AND CAN BE CONVERTED TO FEET BY DIVIDING BY 0.3048
GRID SCALE CONVERSION
 DISTANCES ARE GRID AND CAN BE CONVERTED TO GRID BY MULTIPLYING BY THE COMBINED SCALE FACTOR OF 0.999943.
BEARING NOTE
 BEARINGS ARE GRID, DERIVED FROM THE CAN-NET VRS NETWORK GPS OBSERVATIONS ON NCC HORIZONTAL CONTROL MONUMENTS 19773035 AND 19801911, CENTRAL MERIDIAN 76°30' WEST LONGITUDE WITH ZONE 9, NAD83 (ORIGINAL).
ELEVATION NOTE
 ELEVATIONS SHOWN HEREIN ARE GEODETIC (CGVD-1928/1978) AND ARE DERIVED FROM THE CAN-NET VRS NETWORK.

LEGEND

| Symbol | Denotes |
|--------|--|
| □ | FOUND MONUMENTS |
| ■ | SET MONUMENTS |
| IB | IRON BAR |
| SB | ROUNDER IRON BAR |
| SIB | STANDARD IRON BAR |
| SSB | SHORT STANDARD IRON BAR |
| CC | CUT CROSS |
| CP | CONCRETE PIN |
| CM | CONTROL MONUMENT |
| MIT | WITNESS |
| FIN | PROPERTY IDENTIFICATION NUMBER |
| MEAS | MEASURED |
| PROP | PROPOSED |
| OU | ORIGIN UNCHANGED |
| ORP | OBSERVED REFERENCE POINT |
| P1 | PLAN 48-30019 |
| P2 | PLAN 48-28990 |
| P3 | PLAN 48-31179 |
| P4 | PLAN 48-21148 |
| PS | PLAN 48-21915 |
| (B) | BELOW |
| NCL | NCL LIMIT |
| HP | HORIZONTAL PLANE DETERMINED BY ELEVATION |
| VP | VERTICAL PLANE DETERMINED BY DISTANCE |
| UPP | UNUSABLE FOR POSTING |
| (P1) | ACCEPTED COORDINATE POINT PER P1 |
| (P4) | ACCEPTED COORDINATE POINT PER P4 |

Point Table

| Point No. | Northing | Easting |
|-----------|------------|-----------|
| 5133*-1 | 5030801.58 | 366808.17 |
| 5134*-1 | 5030839.99 | 366565.15 |
| 1-4 | 5030894.47 | 366638.07 |
| 3-4 | 5030996.11 | 366648.50 |

3rd MTM ZONE 9
 CENTRAL MERIDIAN LONGITUDE 76°30'W
 FALSE EASTING: 304800
 SCALE FACTOR: 0.9999
 COMBINED LOCAL SEA LEVEL SCALE FACTOR: 0.999943
 DATUM: NAD 83 (ORIGINAL ADJUSTMENT)

OBSERVED REFERENCE POINTS DERIVED FROM THE CAN-NET VRS NETWORK GPS OBSERVATIONS ON NCC HORIZONTAL CONTROL MONUMENTS 19773035 AND 19801911, CENTRAL MERIDIAN 76°30' WEST LONGITUDE WITH ZONE 9, NAD83 (ORIGINAL). COORDINATES TO URBAN ACCURACY PER SEC 14(2) OF O. REG. 214/10

| ORP ID | NORTHING | EASTING |
|--------|------------|------------|
| ① | 500840.120 | 366630.205 |
| ② | 503043.484 | 366699.184 |

COORDINATES CANNOT IN THEMSELVES BE USED TO RE-ESTABLISH CORNERS OR BOUNDARIES SHOWN ON THIS PLAN.

SURVEYOR'S CERTIFICATE
 I CERTIFY THAT:
 1. THIS SURVEY AND PLAN ARE CORRECT AND IN ACCORDANCE WITH THE SURVEYS ACT, THE SURVEYORS ACT AND THE LAND TITLES ACT AND THE REGULATIONS MADE UNDER THEM.
 2. THE SURVEY WAS COMPLETED ON THE 29th DAY OF JULY, 2019.

Nov 14/19
 DATE

B. Webster
 BRIAN J. WEBSTER
 ONTARIO LAND SURVEYOR

CITY OF OTTAWA - SURVEYS & MAPPING FILE: **Stantec Geomatics Ltd.**
Stantec
 CANADA LAND SURVEYORS
 ONTARIO LAND SURVEYORS
 1311 CLYDE AVENUE, SUITE 400
 OTTAWA, ONTARIO, CANADA K1R 0S4
 TEL: 613.722.4000 FAX: 613.722.7279
 1919165.COM

DRAWN: ME CHECKED: TH PIN: TH FIELD: AW/CA PROJECT NO.: 16413858-114

THIS PLAN IS TO BE DEPOSITED UNDER THE LAND TITLES ACT.
 DATE: Nov 14/19
 RECEIVED AND DEPOSITED
 DATE: Nov 14/2019
 RECEIVED AND DEPOSITED
 REPRESENTATIVE FOR THE LAND REGISTRAR FOR THE LAND DIVISION OF OTTAWA-CARLETON NO. 4

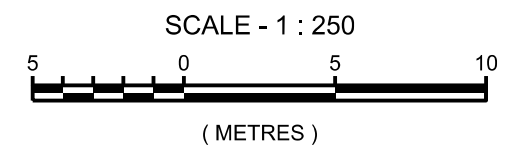
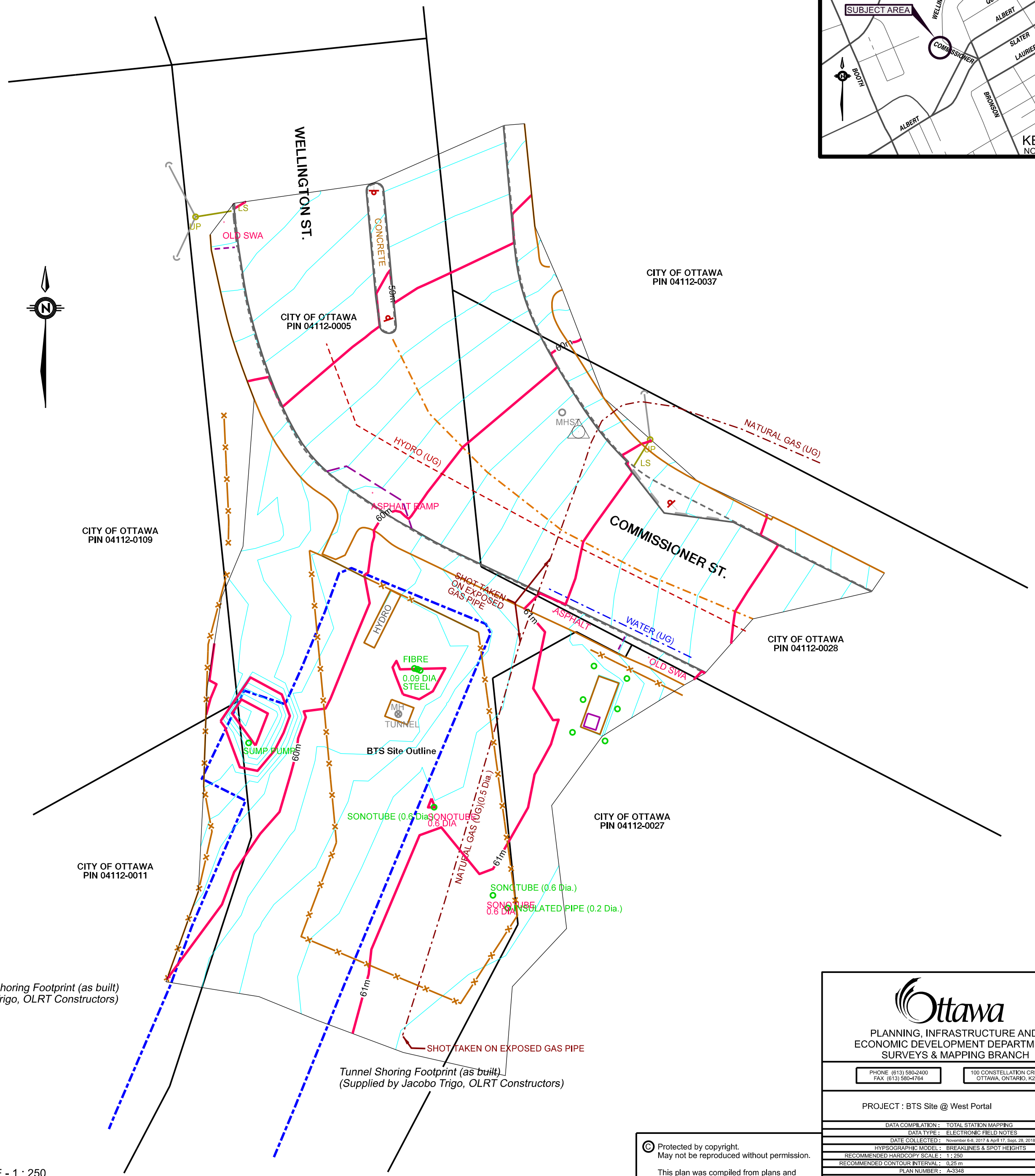
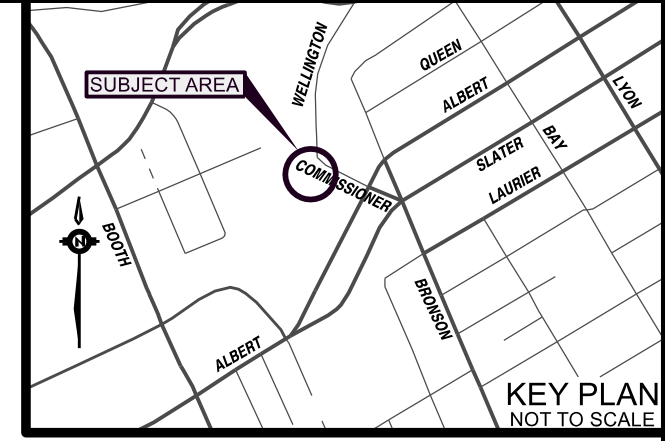

Tunnel Shoring Footprint (as built)
(Supplied by Jacobo Trigo, OLRT Constructors)

Tunnel Shoring Footprint (as built)
(Supplied by Jacobo Trigo, OLRT Constructors)

THIS IS NOT A PLAN OF SURVEY
Boundaries shown hereon are not based on an actual survey.
Contractors are required to verify boundary locations in the field
prior to commencing construction.

© Protected by copyright.
May not be reproduced without permission.

This plan was compiled from plans and documents recorded in the Land Registry System and has been prepared for property indexing purposes only.

Easements noted on the plan may or may not encumber the entire P.I.N.

PLANNING, INFRASTRUCTURE AND ECONOMIC DEVELOPMENT DEPARTMENT
SURVEYS & MAPPING BRANCH

| | |
|--|--|
| PHONE: (613) 590-2400 FAX: (613) 590-4764 | 100 CONSTELLATION CRESCENT OTTAWA, ONTARIO, K2G 6J8 |
| PROJECT : BTS Site @ West Portal | |
| DATA COMPILATION : TOTAL STATION MAPPING DATA TYPE : ELECTRONIC FIELD NOTES DATE COLLECTED : November 6-8, 2017 & April 17, Sept. 28, 2018 (DC), May 9, 2020 HYPSOGRAPHIC MODEL : BREAKLINES & SPOT HEIGHTS RECOMMENDED HARD COPY SCALE : 1 : 250 RECOMMENDED CONTOUR INTERVAL : 0.25 m PLAN NUMBER : A-3348 COMPUTER GRAPHICS FILE NAME : 14152p035-topo-rev04.dgn | |
| CADASTRAL COMPILATION BY : rrw / wsl | DATE : April 18 - May 20 |
| MAP CHECK : rrw / wsl/dc | DATE : October 2, 2018 |
| CADASTRAL COMPILATION CHECK : dc | DATE : Oct /18 - April 20 |
| THIS MAP DEPICTS DIGITAL DATA | |
| © COPYRIGHT 2020 (CITY OF OTTAWA) | |
| A-3348 | |

27 June 2019 10:05 AM



Stantec Geomatics Ltd.
400 - 1331 Clyde Avenue
Ottawa ON
Tel. 613.722.4420
www.stantec.com

© Copyright 2019 Stantec Geomatics Ltd. The reproduction, alteration or use of this REPORT in whole or in part without the express permission of Stantec Geomatics Ltd. is STRICTLY PROHIBITED.

TOPOGRAPHIC SKETCH OF BLOCK L, M & P REGISTERED PLAN 2 LOTS 1 TO 4 REGISTERED PLAN 9481 CITY OF OTTAWA



METRIC CONVERSION
DISTANCES AND COORDINATES SHOWN ON THIS PLAN ARE IN METRES AND CAN BE CONVERTED TO FEET BY DIVIDING BY 0.3048

HORIZONTAL DATUM NOTE
PROJECTION: MODIFIED TRANSVERSE MERCATOR
(MTM, ZONE 9, CM76'30W)
DATUM: NAD 83 (ORIGINAL)

DISTANCES ON THIS PLAN MAY BE CONVERTED TO GROUND DISTANCES BY DIVIDING BY A COMBINED SCALE FACTOR OF 0.999942

VERTICAL DATUM NOTE
ELEVATIONS ARE REFERRED TO THE CANADIAN GEODETIC VERTICAL DATUM (CGVD-1928/1978) AND ARE DERIVED FROM BENCHMARK MONUMENT NO. 2011-0170, HAVING A PUBLISHED ELEVATION OF 62.711 METRES.

BOUNDARY NOTE
BOUNDARY INFORMATION SHOWN HEREON HAS BEEN COMPILED FROM VARIOUS SOURCES AND MUST BE VERIFIED PRIOR TO CONSTRUCTION.

| LEGEND | DENOTES | FOUND MONUMENTS |
|--------|---------|---|
| ■ | IB | IRON BAR |
| □ | IB# | ROUND IRON BAR |
| □ | SIB | STANDARD IRON BAR |
| □ | SIB# | SHORT STANDARD IRON BAR |
| □ | CC | CUT CROSS |
| □ | CP | CONCRETE PIN |
| □ | WIT | WIRE |
| □ | PIN | PROPERTY IDENTIFICATION NUMBER |
| □ | MEAS | MEASURED |
| □ | PROP | PROPORTIONED |
| □ | OU | ORIGIN UNKNOWN |
| □ | SG | STANTEC GEOMATICS LTD. |
| □ | ORP | STANTEC GEOMATICS LTD. OBSERVED REFERENCE POINT |
| □ | ACU | AIR CONDITIONING UNIT |
| □ | AN | ANCHOR |
| □ | AP | AIR PUMP |
| □ | ANT | ANTENNA |
| □ | BH | BORERHOLE |
| □ | BIB | HOSE BIB |
| □ | BKR | BIKE RACK |
| □ | BENCH | BENCH |
| □ | BOL | BOLLARD |
| □ | BOUL | BOULDER |
| □ | CB | CATCH BASIN |
| □ | DCB | DOUBLE CB |
| □ | DICB | DITCH CB |
| □ | CBMH | CB MANHOLE |
| □ | DCBHM | DOUBLE CB MANHOLE |
| □ | CBSI | SIDE INLET CB |
| □ | CHM | CHIMNEY |
| □ | CSY | VALVE CURB STOP |
| □ | DRN | DRAIN |
| □ | EPCST | ELECTRICAL OUTLET |
| □ | FP | FLAG POLE |
| □ | FL | FLOOD LIGHT |
| □ | FTF | FUEL TANK FILLER CAP |
| □ | GC | GARRAGE CAN |
| □ | GFL | PIPE FLANGE (GAS) |
| □ | GFP | GAS FUEL PUMP |
| □ | GP | POLE GUYWIRE |
| □ | GSR | GAS SERVICE REGULATOR |
| □ | GV | GAS VALVE |
| □ | HIC | HICKENBOTTOM |
| □ | HOS | HOSE |
| □ | HLS | LIGHT STANDARD HYDRO |
| □ | HM | HYDRO METER |
| □ | HTN | HYDRO TRANSFORMER |
| □ | HW | HAND WELL |
| □ | HYD | FIRE HYDRANT |
| □ | JBX | JUNCTION BOX |
| □ | KALBX | KALEBOX |
| □ | MP | MONITORING PIN |
| □ | MH | MAINTENANCE HOLE UNIDENTIFIED |
| □ | MHBL | MAINTENANCE HOLE BELL |
| □ | MHF | MAINTENANCE HOLE FIBRE OPTIC |
| □ | MHH | MAINTENANCE HOLE HYDRO |
| □ | MHI | MAINTENANCE HOLE INVERT |
| □ | MHSAN | MAINTENANCE HOLE SANITARY |
| □ | MHSTM | MAINTENANCE HOLE STORM |
| □ | MHT | MAINTENANCE HOLE TRAFFIC |
| □ | MW | MONITORING WELL |
| □ | NPB | NEWS PAPER BOX |
| □ | OLP | LIGHT STANDARD ORNAMENTAL |
| □ | OW | OBSERVATION WELL |
| □ | PKM | PARKING METER |
| □ | PLBY | PULL BOX |
| □ | SH | SIGN |
| □ | TB | TERMINAL BOX - BELL |
| □ | TB | TERMINAL BOX - CABLE |
| □ | TCTB | TRAFFIC CONTROL BOX |
| □ | TYT | TEST PIT |
| □ | TSL | TRAFFIC SIGNAL LIGHT |
| □ | UP | UTILITY POLE |
| □ | VB | VALVE BOX |
| □ | VC | VALVE CHAMBER |
| □ | WV | WATER VALVE |
| □ | RV | TREE STUMP |
| □ | | TREE CONIFEROUS |
| □ | | TREE DECIDUOUS |
| □ | | UNDERGROUND CABLE |
| □ | | UNDERGROUND GAS LINE |
| □ | | UNDERGROUND HYDRO |
| □ | | UNDERGROUND TELEPHONE |
| □ | | UNDERGROUND WATER MAIN |

REVISION NOTE
PLAN REVISED TO SHOW FIELD LOCATION OF UNDERGROUND UTILITIES
ON JUNE 14, 2019.

June 27/19
DATE

T. HARTWICK
ONTARIO LAND SURVEYOR

SURVEYOR'S CERTIFICATE
I CERTIFY THAT:
1. THE SURVEY WAS COMPLETED ON THE 18th DAY OF OCTOBER, 2019.

Oct 18
DATE

T. HARTWICK
ONTARIO LAND SURVEYOR

DRAWN: TMT CHECKED: TH PM: TH FIELD: SJ/AW PROJECT NO.: 161613858-111



Appendix F

Relevant As-Builts

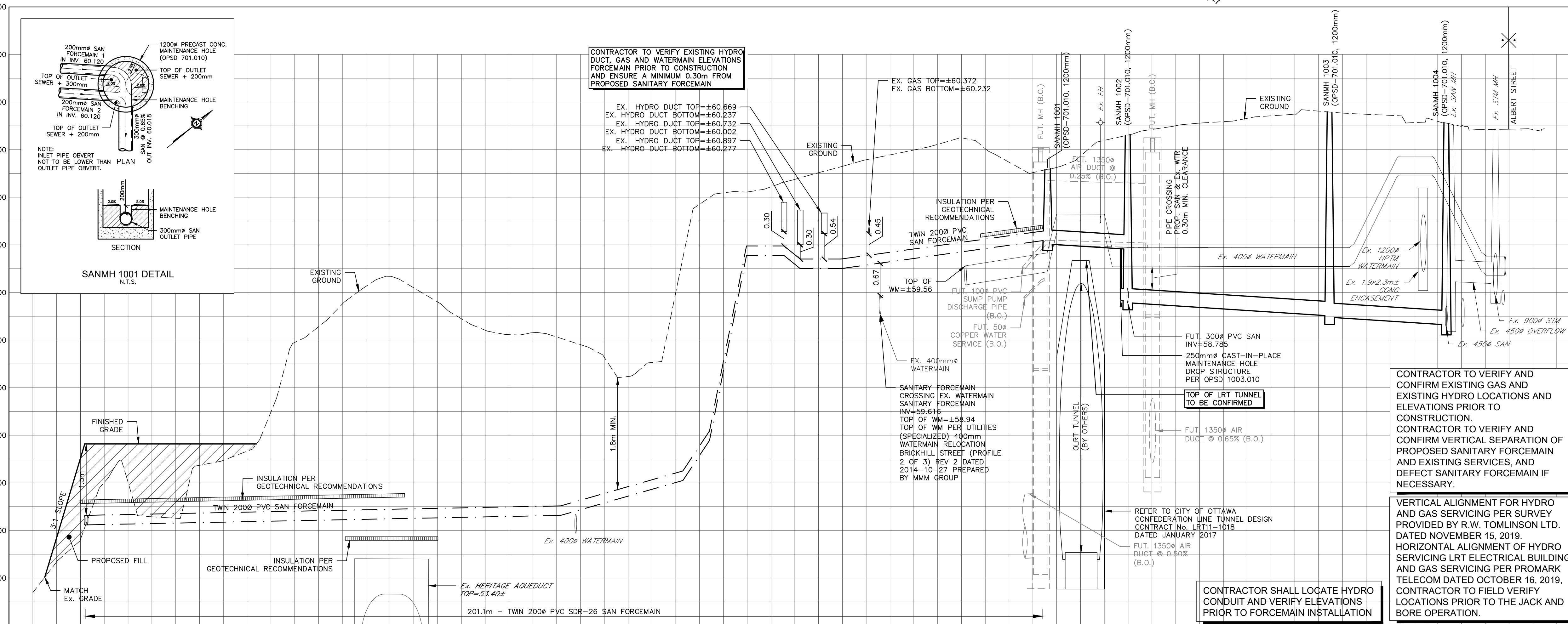
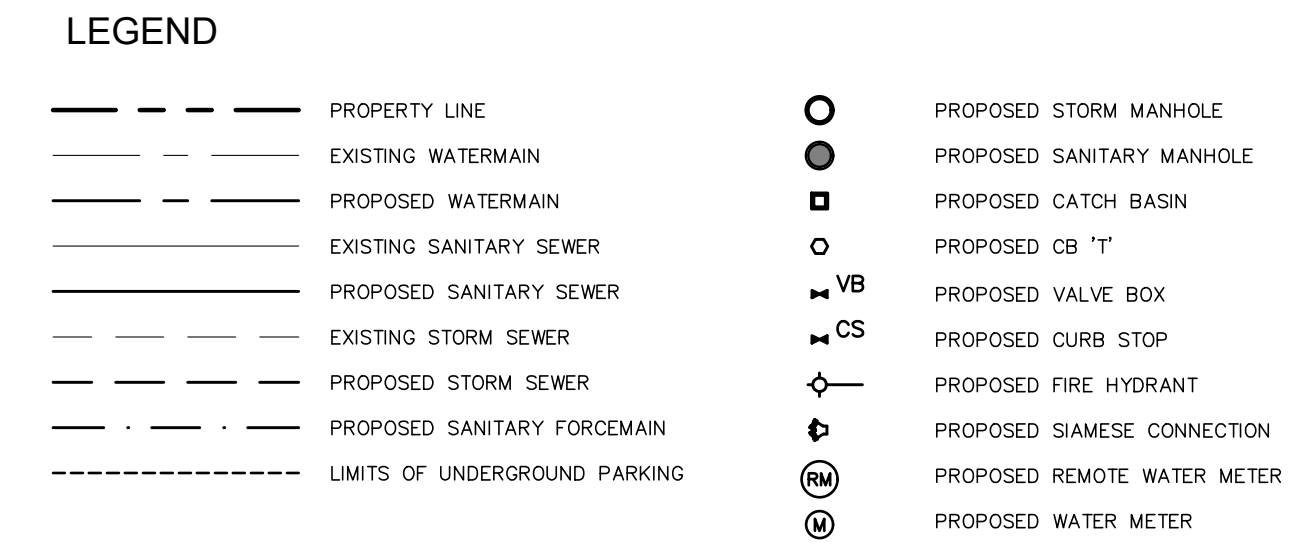
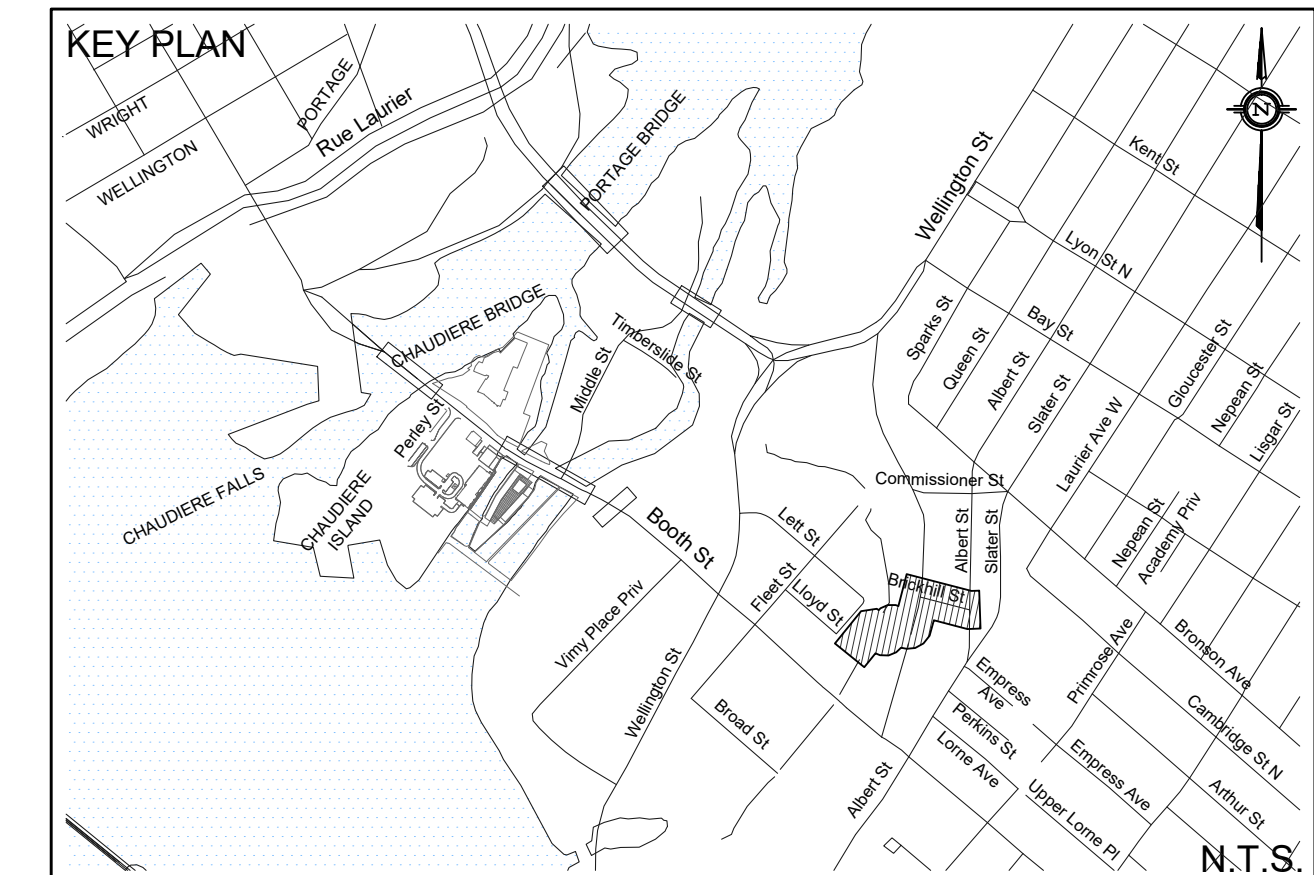
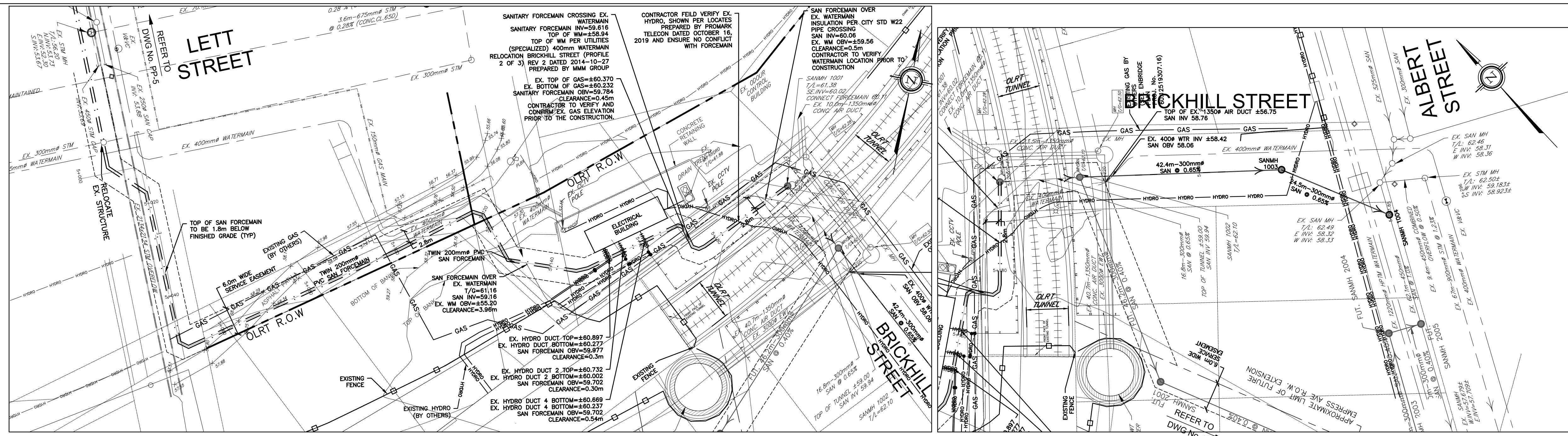

THIS PLAN TO BE READ IN CONJUNCTION WITH DS-1.

EXISTING UNDERGROUND SERVICES AND UTILITY LOCATIONS DERIVED FROM THE BEST AVAILABLE DATA, AS-CONSTRUCTED DRAWINGS, UTILITY DRAWINGS AND INFRASTRUCTURE MAPPING PROVIDED BY THE CITY OF OTTAWA.

CONTRACTOR TO CONFIRM ELEVATIONS AND LOCATIONS OF EXISTING UNDERGROUND SERVICES AND UTILITIES WITHIN THE RIGHT OF WAY PRIOR TO INSTALLATION OF SITE SERVICING INFRASTRUCTURE.

THE CONTRACTOR SHALL IMPLEMENT BEST MANAGEMENT PRACTICES, TO PROVIDE FOR PROTECTION OF THE AREA DRAINAGE SYSTEM AND THE RECEIVING WATERCOURSE, DURING CONSTRUCTION ACTIVITIES. THE CONTRACTOR ACKNOWLEDGES THAT THE FAILURE TO IMPLEMENT APPROPRIATE EROSION AND SEDIMENT CONTROL MEASURES MAY BE SUBJECT TO PENALTIES IMPOSED BY ANY APPLICABLE REGULATORY AGENCY.

TOPOGRAPHIC INFORMATION
BRICKHILL STREET TOPOGRAPHIC INFORMATION PROVIDED BY STANTEC GEOMATICS LIMITED
PROJECT NO. 161613467-211.001
DATED OCTOBER 08, 2019

QLRT CORRIDOR INFORMATION
QLRT CORRIDOR INFORMATION PROVIDED BY THE CITY OF OTTAWA
PREPARED BY GOODEVE MANHIRE PARTNERS INC.
PROJECT NO. 13-115
RECEIVED SEPTEMBER 27, 2019

SITE PLAN INFORMATION
SITE PLAN PROVIDED BY HOBIN ARCHITECTURE INC.
PROJ. NO. 1508.00
RECEIVED AUGUST 29, 2019

GEOTECHNICAL STUDY
GEOTECHNICAL RECOMMENDATIONS PROVIDED BY EXP SERVICES INC.
PROJ. NO. OTT-02250193-A0
DATED JANUARY 21, 2019

BENCH MARK
MULTIPLE ON-SITE AS PER SURVEY

SITE SERVICING AND STORMWATER MANAGEMENT STUDY
SERVICING AND STORMWATER MANAGEMENT RECOMMENDATIONS PROVIDED BY DSEL
PROJ. NO. 14-717
DATED AUGUST 2018

| NO. | BY | YY.MM.DD | DESCRIPTION |
|-----|--------|----------|--|
| 12 | S.L.M. | 19.12.09 | UPDATED PER OC TRANSPO COMMENTS |
| 11 | S.L.M. | 19.11.25 | UPDATED JACK AND BORE DETAILS |
| 10 | S.L.M. | 19.06.03 | UPDATED WATERMAIN AT PIPE BRIDGE |
| 9 | A.A.S. | 19.05.02 | UPDATED PER REVISED PIPE BRIDGE LAYOUT |
| 8 | B.N.C. | 19.01.25 | ISSUED FOR MUNICIPAL REVIEW |
| 7 | B.N.C. | 18.11.22 | ISSUED FOR MUNICIPAL REVIEW |
| 6 | B.N.C. | 18.10.25 | ISSUED FOR M.O.E. REVIEW AND APPROVAL |
| 5 | B.N.C. | 18.08.09 | ISSUED FOR MUNICIPAL REVIEW |
| 4 | B.N.C. | 18.06.29 | ISSUED FOR MUNICIPAL REVIEW |

| TOP OF WATERMAIN | TOP OF SANITARY FORCEMAIN | SANITARY INVERT | STORM INVERT | PROPOSED CENTERLINE GRADES | CENTERLINE CHAINAGE | TOP OF WATERMAIN | TOP OF SANITARY FORCEMAIN | SANITARY INVERT | STORM INVERT | PROPOSED CENTERLINE GRADES | CENTERLINE CHAINAGE |
|------------------|---------------------------|-----------------|--------------|----------------------------|---------------------|------------------|---------------------------|-----------------|--------------|----------------------------|---------------------|
| | 54.316 | | | 55.818 | 5+000.000 | | | | | | |
| | 54.345 | | | 55.818 | 5+005.898 | | | | | | |
| | 54.385 | | | 55.818 | 5+020.000 | | | | | | |
| | 54.425 | | | 55.818 | 5+040.000 | | | | | | |
| | 54.465 | | | 55.818 | 5+060.000 | | | | | | |
| | 54.505 | | | 55.818 | 5+100.000 | | | | | | |
| | 54.517 | | | 55.818 | 5+105.840 | | | | | | |
| | 54.921 | | | 55.818 | 5+120.000 | | | | | | |
| | 55.250 | | | 55.818 | 5+131.500 | | | | | | |
| | 59.977 | | | 55.818 | 5+140.000 | | | | | | |
| | 59.977 | | | 55.818 | 5+152.605 | | | | | | |
| | 59.702 | | | 55.818 | 5+155.963 | | | | | | |
| | 59.702 | | | 55.818 | 5+156.149 | | | | | | |
| | 59.784 | | | 55.818 | 5+161.882 | | | | | | |
| | 60.310 | | | 55.818 | 5+170.594 | | | | | | |
| | 60.310 | | | 55.818 | 5+172.914 | | | | | | |
| | 60.310 | | | 55.818 | 5+180.000 | | | | | | |
| | 61.600 | | | 55.818 | 5+200.000 | | | | | | |
| | 62.306 | | | 55.818 | 5+207.090 | | | | | | |
| | 62.306 | | | 55.818 | 5+220.000 | | | | | | |
| | 62.306 | | | 55.818 | 5+223.920 | | | | | | |
| | 62.559 | | | 55.818 | 5+240.000 | | | | | | |
| | 62.559 | | | 55.818 | 5+260.000 | | | | | | |
| | 62.559 | | | 55.818 | 5+266.300 | | | | | | |
| | 62.791 | | | 55.818 | 5+280.000 | | | | | | |
| | 62.791 | | | 55.818 | 5+291.850 | | | | | | |
| | 62.791 | | | 55.818 | 5+300.000 | | | | | | |

PROJECT No. 14-717

BRICKHILL STREET - PLAN & PROFILE
(STA 5+000.00 TO STA 5+300.00)
ZIBI OFF-SITE - ONTARIO (PHASE 1)

DSEL

1306 Wellington Street W., Suite 201
Ottawa, Ontario, K1Y 3B2
Tel. (613) 820-5600

120 Iber Road Unit 103
Stittsville, Ontario, K2S 1E9
Tel. (613) 836-0556
Fax. (613) 836-7183
www.DSEL.ca

15 Allstate Parkway
Markham, Ontario, L3R 9B4
Tel. (905) 943-9600
Fax. (905) 940-5848
www.hatch.com

DRAWN BY: B.N.C. CHECKED BY: S.L.M.
DESIGNED BY: B.N.C. CHECKED BY: A.D.F.
SCALE: H 1:500, V 1:50 DATE: JANUARY 2019

DRAWING NO. SHEET 13 OF 17

mmkshy

SDGN_FILE_NAMES

NOTE: REFER TO SHOP DRAWINGS FOR THRUST RESTRAINT DETAILS

AS-BUILT

RECORD INFORMATION PROVIDED BY CITY OF OTTAWA
 ALL NUMERICAL VALUES THAT ARE NOT STROKED OUT AND REPLACED IN ITALICS ON AS-BUILT DRAWINGS ARE CONSIDERED TO BE DESIGN VALUES ONLY AND NOT MEASURED IN THE FIELD.

**Robinson
Consultants**

| NO. | REVISIONS | BY | DATE |
|-----|-------------------------|-----|----------|
| 1 | ISSUED FOR TENDER | JDL | 14.02.07 |
| 2 | ISSUED FOR CONSTRUCTION | JDL | 01.08.07 |
| 3 | AS BUILT | DEP | 30.08.10 |

NOTE:
 The location of the utilities is approximate only, the exact location should be determined by consulting the municipal authorities and utility companies concerned.
 The contractor shall prove the location of utilities and shall be responsible for adequate protection from damage.

LEMIEUX ISLAND TRANSMISSION MAIN
 REPLACEMENT PROGRAM
 HIGH PRESSURE TRANSMISSION MAIN
 CITY CENTRE AVENUE TO COMMISSIONER STREET

PLAN & PROFILE
 STA. 5+820 TO 5+960

Ottawa

CONTRACT NO.
 ISB06-3018
 DWG. NO.
 063018-C17

SHEET . . . OF
 Date: DECEMBER 2006
 Scale: HORIZONTAL
 0m 2.5 5 10

M. J. WILLMETS
 Project Manager

W. R. NEWELL, P. ENG.
 Director Infrastructure Services

B. MASON, P. ENG.
 Manager Construction Services West

Dir: I.D.M./D.H. Cht: J.D.L. Des: Cht:

MATCH LINE STA. 5+820

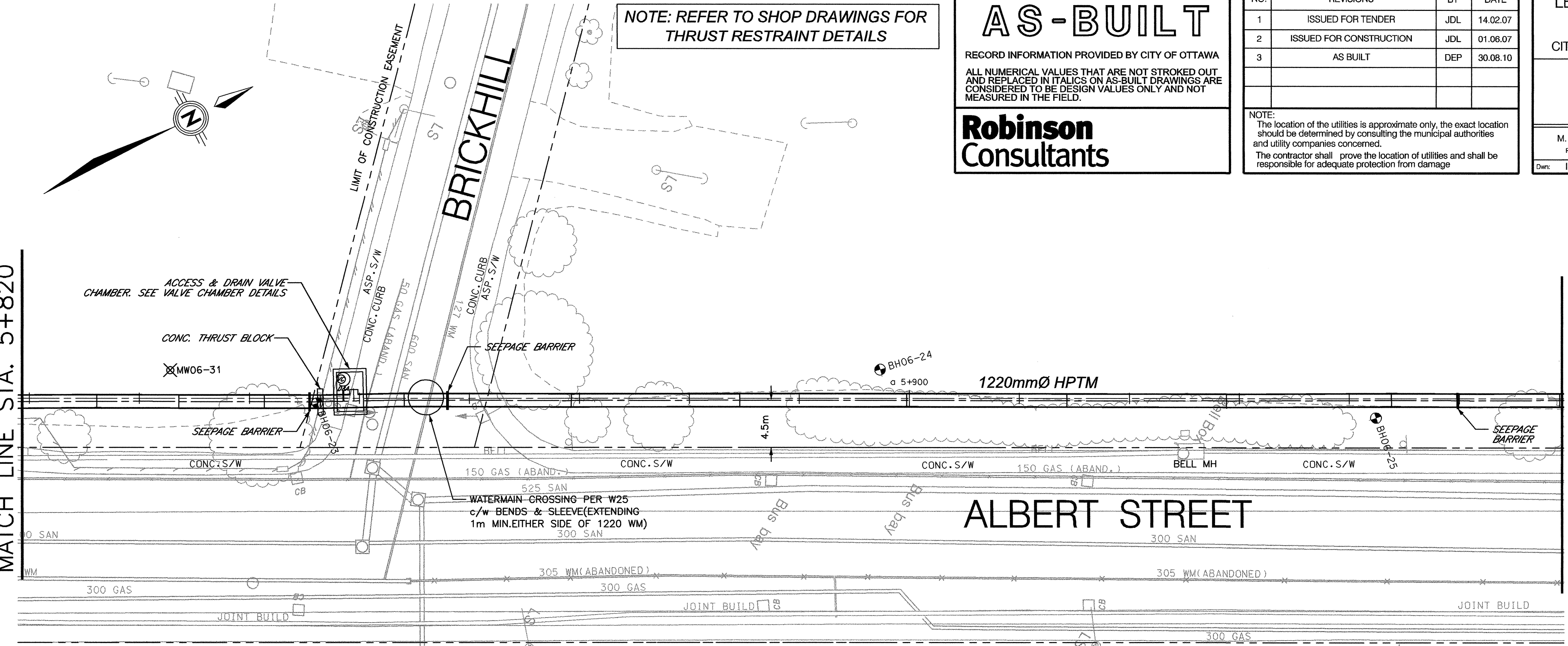

MATCH LINE STA. 5+960

- NOTES:**
1. ALL WATERMAIN MATERIALS AND CONSTRUCTION SHALL BE IN ACCORDANCE WITH THE LATEST EDITION OF THE CITY OF OTTAWA STANDARD SPECIFICATIONS AND STANDARD DRAWINGS EXCEPT AS AMENDED BY THE HPTM CONTRACT ISB063018 SPECIFICATIONS.
 2. REINSTATEMENT SHALL BE IN ACCORDANCE WITH THE REQUIREMENTS OF THE CITY OF OTTAWA OR AS SPECIFIED.
 3. CONTRACTOR TO SUPPLY, INSTALL AND MAINTAIN FENCE ALONG LIMITS OF CONSTRUCTION EASEMENT.
 4. FULL DEPTH AND WIDTH SEEPAGE BARRIERS SHALL BE CONSTRUCTED AT A MAXIMUM SPACING OF 100m AND WHERE NOTED ALONG THE WATERMAIN. REFER TO DETAIL.
 5. REFER TO THE GEOTECHNICAL REPORT PHASE II ESA FOR SUBSURFACE INFORMATION AND RECOMMENDATIONS.
 6. SEE STRUCTURAL DRAWINGS FOR CONCRETE THRUST BLOCK DETAILS.
 7. REFER TO SPECIFICATIONS FOR NIGHT TIME & WEEKEND WORK REQUIREMENTS.
 8. ELEVATION OF CONNECTIONS TO EXISTING WATERMAINS TO BE DETERMINED BY THE CONTRACTOR DURING CONSTRUCTION. EXCAVATION & BACKFILL TO BE THE RESPONSIBILITY OF THE CONTRACTOR. CONNECTIONS TO BE MADE BY CITY OF OTTAWA FORCES UNLESS NOTED OTHERWISE.

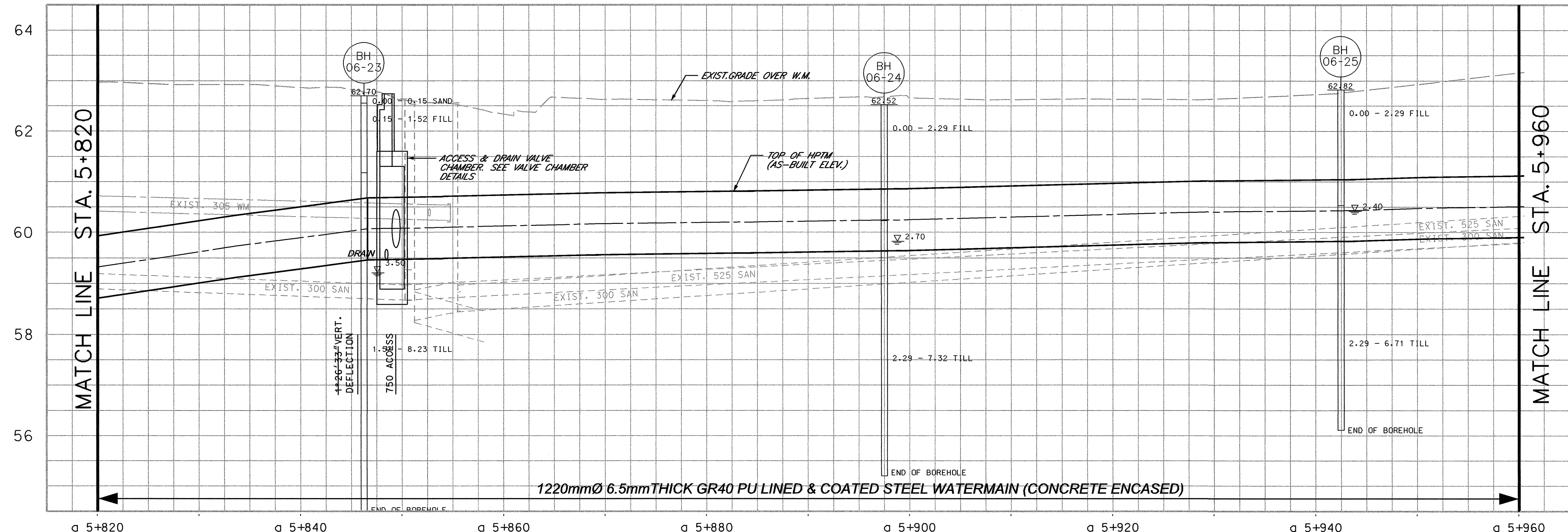

| DESIGN ALIGNMENT COORDINATE SCHEDULE | | |
|--------------------------------------|-------------|------------|
| POINT | NORTHING | EASTING |
| ① | 5030313.057 | 365964.22 |
| ② | 5030332.124 | 365956.052 |
| ③ | 5030356.989 | 365961.041 |
| ④ | 5030768.864 | 365008.797 |
| ⑤ | 5030613.886 | 366376.388 |
| ⑥ | 5030716.864 | 366544.552 |
| ⑦ | 5030749.110 | 366585.769 |
| ⑧ | 5030956.635 | 366693.229 |
| ⑨ | 5030972.240 | 366688.371 |
| ⑩ | 5030977.737 | 366691.098 |

ISSUED

| | | | | | | | | | | | | | | | | | | | | | | | | | | | | | | | | | | | | | | | | | | | | | | | | |
|--------------------|--------|--------|--------|--------|--------|--------|--------|--------|--------|--------|--------|--------|--------|--------|--------|--------|--------|--------|--------|--------|--------|--------|--------|--------|--------|--------|--------|--------|--------|--------|--------|--------|--------|--------|--------|--------|--------|--------|--------|--------|--------|--------|--------|--------|--------|--------|--------|--------|
| FINISHED GRADE | 62.98 | 62.98 | 62.98 | 62.98 | 62.98 | 62.98 | 62.98 | 62.98 | 62.98 | 62.98 | 62.98 | 62.98 | 62.98 | 62.98 | 62.98 | 62.98 | 62.98 | 62.98 | 62.98 | 62.98 | 62.98 | 62.98 | 62.98 | 62.98 | 62.98 | 62.98 | 62.98 | 62.98 | 62.98 | 62.98 | 62.98 | 62.98 | 62.98 | 62.98 | 62.98 | 62.98 | 62.98 | 62.98 | 62.98 | 62.98 | 62.98 | 62.98 | 62.98 | 62.98 | 62.98 | | | |
| AS BUILT TOP OF WM | 59.39 | 60.11 | 60.24 | 60.24 | 60.24 | 60.24 | 60.24 | 60.24 | 60.24 | 60.24 | 60.24 | 60.24 | 60.24 | 60.24 | 60.24 | 60.24 | 60.24 | 60.24 | 60.24 | 60.24 | 60.24 | 60.24 | 60.24 | 60.24 | 60.24 | 60.24 | 60.24 | 60.24 | 60.24 | 60.24 | 60.24 | 60.24 | 60.24 | 60.24 | 60.24 | 60.24 | 60.24 | 60.24 | 60.24 | 60.24 | 60.24 | 60.24 | 60.24 | 60.24 | 60.24 | 60.24 | 60.24 | |
| STATION | +820.0 | +822.1 | +824.2 | +826.3 | +828.4 | +830.5 | +832.6 | +834.7 | +836.8 | +838.9 | +841.0 | +843.1 | +845.2 | +847.3 | +849.4 | +851.5 | +853.6 | +855.7 | +857.8 | +859.9 | +862.0 | +864.1 | +866.2 | +868.3 | +870.4 | +872.5 | +874.6 | +876.7 | +878.8 | +880.9 | +883.0 | +885.1 | +887.2 | +889.3 | +891.4 | +893.5 | +895.6 | +897.7 | +899.8 | +901.9 | +904.0 | +906.1 | +908.2 | +910.3 | +912.4 | +914.5 | +916.6 | +918.7 |

NOTE: REFER TO SHOP DRAWINGS FOR THRUST RESTRAINT DETAILS

AS-BUILT

RECORD INFORMATION PROVIDED BY CITY OF OTTAWA
 ALL NUMERICAL VALUES THAT ARE NOT STROKED OUT AND REPLACED IN ITALICS ON AS-BUILT DRAWINGS ARE CONSIDERED TO BE DESIGN VALUES ONLY AND NOT MEASURED IN THE FIELD.

Robinson Consultants

| NO. | REVISIONS | BY | DATE |
|-----|-------------------------|-----|----------|
| 1 | ISSUED FOR TENDER | JDL | 14.02.07 |
| 2 | ISSUED FOR CONSTRUCTION | JDL | 01.06.07 |
| 3 | AS BUILT | DEP | 30.08.10 |

NOTE:
 The location of the utilities is approximate only, the exact location should be determined by consulting the municipal authorities and utility companies concerned.
 The contractor shall prove the location of utilities and shall be responsible for adequate protection from damage

LEMIEUX ISLAND TRANSMISSION MAIN REPLACEMENT PROGRAM
 HIGH PRESSURE TRANSMISSION MAIN
 CITY CENTRE AVENUE TO COMMISSIONER STREET



CONTRACT NO.
ISB06-3018
 DWG. NO.
063018-C18

PLAN & PROFILE
 STA. 5+960 TO LIMIT OF CONTRACT

M. J. WILLMETS
 Project Manager
 W.R. NEWELL, P.ENG.
 Director Infrastructure Services
 B. MASON, P.ENG.
 Manager Construction Services West

SHEET - OF
 Date: DECEMBER 2008
 Scale: HORIZONTAL
 0m 2.5 5 10

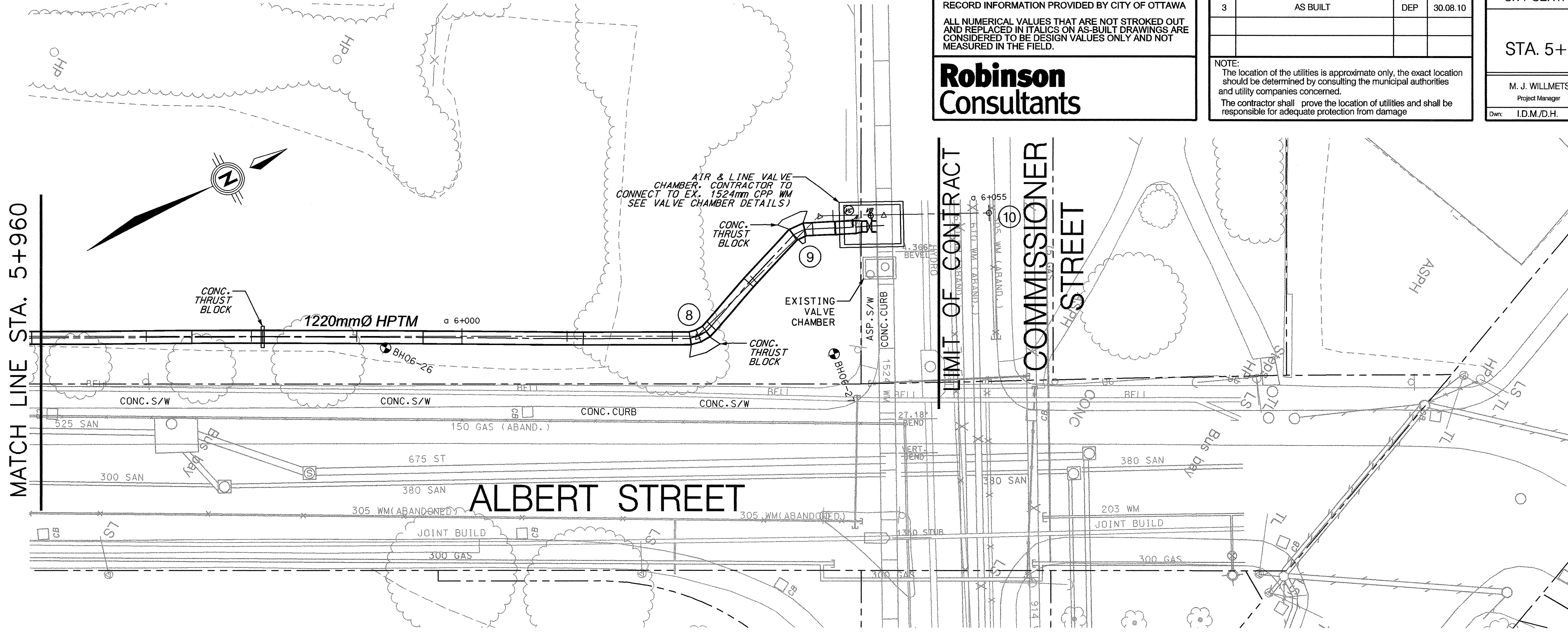

- NOTES:
1. ALL WATERMAIN MATERIALS AND CONSTRUCTION SHALL BE IN ACCORDANCE WITH THE LATEST EDITION OF THE CITY OF OTTAWA STANDARD SPECIFICATIONS AND STANDARD DRAWINGS EXCEPT AS AMENDED BY THE HPTM CONTRACT ISB063018 SPECIFICATIONS.
 2. REINSTATEMENT SHALL BE IN ACCORDANCE WITH THE REQUIREMENTS OF THE CITY OF OTTAWA OR AS SPECIFIED.
 3. CONTRACTOR TO SUPPLY, INSTALL AND MAINTAIN FENCE ALONG LIMITS OF CONSTRUCTION EASEMENT.
 4. FULL DEPTH AND WIDTH SEEPAGE BARRIERS SHALL BE CONSTRUCTED AT A MAXIMUM SPACING OF 100m AND WHERE NOTED ALONG THE WATERMAIN. REFER TO DETAIL.
 5. REFER TO THE GEOTECHNICAL REPORT PHASE II ESA FOR SUBSURFACE INFORMATION AND RECOMMENDATIONS.
 6. SEE STRUCTURAL DRAWINGS FOR CONCRETE THRUST BLOCK DETAILS.
 7. REFER TO SPECIFICATIONS FOR NIGHT TIME & WEEKEND WORK REQUIREMENTS.
 8. ELEVATION OF CONNECTIONS TO EXISTING WATERMAINS TO BE DETERMINED BY THE CONTRACTOR DURING CONSTRUCTION. EXCAVATION & BACKFILL TO BE THE RESPONSIBILITY OF THE CONTRACTOR. CONNECTIONS TO BE MADE BY CITY OF OTTAWA FORCES UNLESS NOTED OTHERWISE.

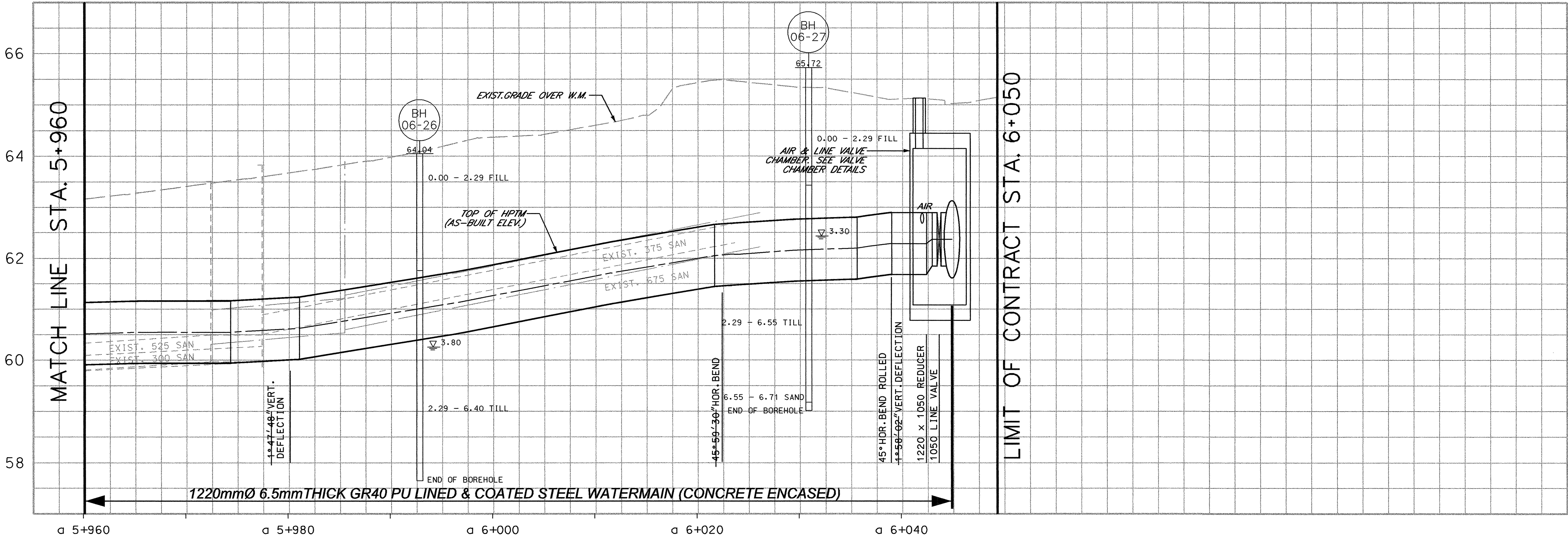

| DESIGN ALIGNMENT COORDINATE SCHEDULE | | |
|--------------------------------------|-------------|------------|
| POINT | NORTHING | EASTING |
| ① | 5030313.057 | 365964.22 |
| ② | 5030332.124 | 365956.052 |
| ③ | 5030356.989 | 365961.041 |
| ④ | 5030768.864 | 365008.797 |
| ⑤ | 5030613.886 | 366376.388 |
| ⑥ | 5030716.864 | 366544.552 |
| ⑦ | 5030749.110 | 366585.769 |
| ⑧ | 5030956.635 | 366693.229 |
| ⑨ | 5030972.240 | 366688.371 |
| ⑩ | 5030977.737 | 366691.098 |

| STATION | AS BUILT TOP OF WM | FINISHED GRADE |
|---------|--------------------|----------------|
| +969.1 | 61.11 | 63.16 |
| +966.0 | 60.44 | |
| +965.3 | 61.15 | |
| +974.3 | 61.15 | |
| +986.0 | 60.50 | 63.67 |
| +987.1 | 61.22 | |
| +996.3 | 61.72 | 64.36 |
| +1011.5 | 62.37 | |
| +1021.6 | 61.87 | 65.42 |
| +1023.3 | 62.85 | 65.48 |
| +1024.0 | 62.85 | |
| +1028.4 | 62.76 | |
| +1035.6 | 62.80 | 65.10 |
| +1036.8 | 62.84 | 65.11 |
| +1038.0 | 62.82 | 65.10 |
| +1042.5 | 62.55 | 65.10 |
| +1044.8 | 62.64 | 65.01 |

ISSUED

AS-BUILT

RECORD INFORMATION PROVIDED BY CITY OF OTTAWA
 ALL NUMERICAL VALUES THAT ARE NOT STROKED OUT AND REPLACED IN ITALICS ON AS-BUILT DRAWINGS ARE CONSIDERED TO BE DESIGN VALUES ONLY AND NOT MEASURED IN THE FIELD.

Robinson Consultants

| NO. | REVISIONS | BY | DATE |
|-----|-------------------------|-----|----------|
| 1 | ISSUED FOR TENDER | JDL | 14.02.07 |
| 2 | ISSUED FOR CONSTRUCTION | JDL | 01.06.07 |
| 3 | AS BUILT | DEP | 30.08.10 |

NOTE:
 The location of the utilities is approximate only, the exact location should be determined by consulting the municipal authorities and utility companies concerned.
 The contractor shall prove the location of utilities and shall be responsible for adequate protection from damage

HIGH PRESSURE TRANSMISSION MAIN REPLACEMENT PROGRAM
 LEMIEUX ISLAND WATER PURIFICATION PLANT TO BRONSON AVENUE



CONTRACT NO. ISB06-3018
 DWG. NO. 063018-C21
 SHEET 17 OF -
 Date: DECEMBER 2006
 Scale: HORIZONTAL
 AS NOTED

ENGINEERING DETAILS

M. J. WILLMETS Project Manager
 W.R. NEWELL, P.ENG. Director Infrastructure Services
 B. MASON, P.ENG. Manager Construction Services West

ALL DIMENSIONS ARE IN mm UNLESS OTHERWISE SHOWN

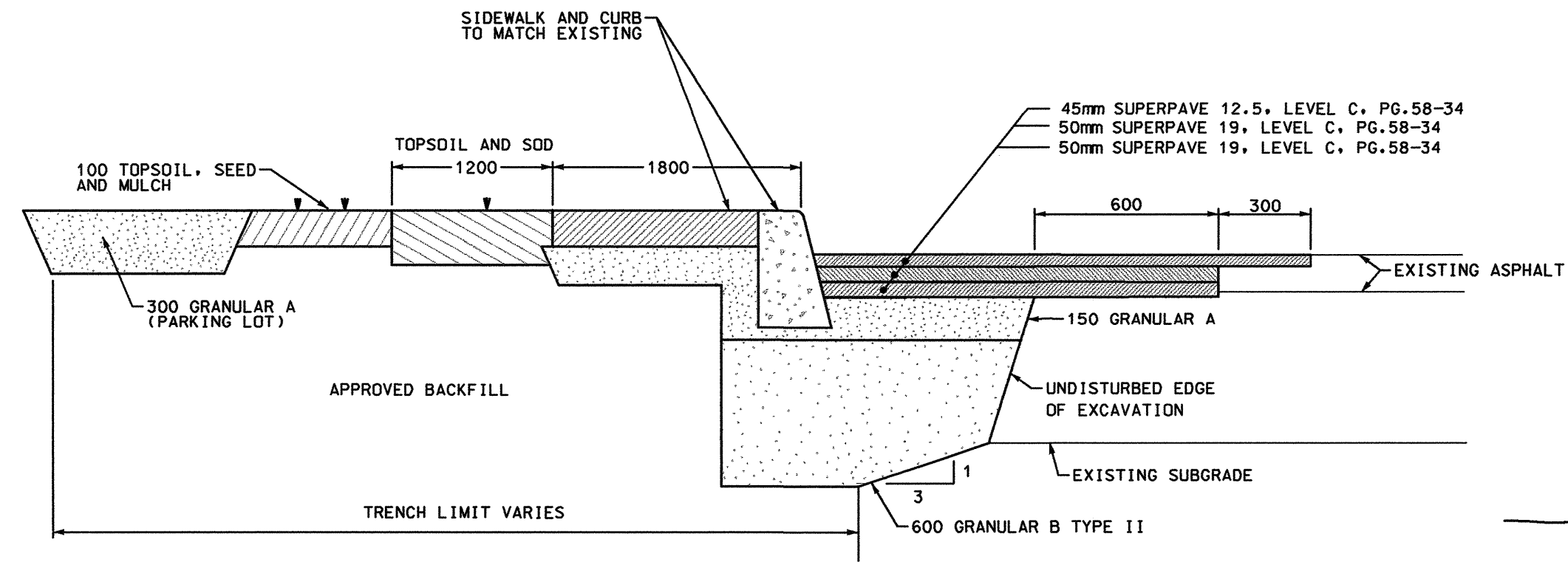

TYPICAL REINSTATEMENT DETAIL
 N. T. S.

NOTES:

- ROADWAY PAVEMENT STRUCTURE SHALL BE REINSTATED TO THE MINIMUM THICKNESSES SHOWN OR TO MATCH EXISTING, (WHICHEVER IS GREATER).
- EXISTING ASPHALT SHALL BE SAWCUT.
- THE KEY SHALL BE 300mm WIDE AND 45mm DEEP AND SHALL BE IN CONFORMANCE WITH CITY OF OTTAWA DETAIL R17.
- GRANULAR MATERIAL SHALL BE COMPACTED TO 100% S.P.M.D.D. (OPSS501 METHOD A)
- CURB, SIDEWALKS, BOULEVARDS & GRAVEL PARKING LOTS SHALL BE REINSTATED IN ACCORDANCE WITH CITY OF OTTAWA SPECIFICATIONS.
- SIDEWALK THAT IS REPLACED SHALL BE REINSTATED A MINIMUM OF 1.8m WIDE. CITY OF OTTAWA STD SC6 AND SC7 SHALL BE APPLIED AT ALL CROSSWALKS. MONOLITHIC CONCRETE CURBS AND SIDEWALK SHALL BE PER CITY OF OTTAWA SC2. BARRIER CURB SHALL BE PER CITY OF OTTAWA SC1.1. TOPSOIL AND SOD SHALL BE INSTALLED A MINIMUM OF 1.2m ON EITHER SIDE OF BOULEVARD SIDEWALKS. PERMANENT ASPHALT SIDEWALK, PERMANENT CONCRETE SIDEWALK, SOD AND TOPSOIL FOR SOD, LOCATED ON THE NORTH SIDE OF ALBERT STREET SHALL BE MEASURED FOR PAYMENT.
- ASPHALT SIDEWALK SHALL BE REINSTATED WITH 50mm OF HL3 ASPHALT AND 200mm GRANULAR A.
- TOPSOIL AND SOD SHALL BE PLACED 1.2 MINIMUM WIDTH ADJACENT TO ALL PERMANENT SIDEWALKS. ALL REMAINING GRASSED AREAS AND PREVIOUSLY VEGETATED AREAS SHALL BE REINSTATED WITH TOPSOIL & SEED.
- PARKING LOTS LOCATED NORTH OF ALBERT BETWEEN BOOTH AND COMMISSIONER SHALL BE FINE GRADED AND CAPPED WITH 25mm OF COMPACTED GRANULAR A UPON COMPLETION.
- THE ROADWAY PAVEMENT STRUCTURE FOR BRICK-HILL STREET AND WELLINGTON STREET SHALL MATCH EXISTING OR SHALL BE REINSTATED WITH THE FOLLOWING MINIMUM THICKNESSES, WHICHEVER IS GREATER:
 40mm SUPERPAVE 12.5, LEVEL B, PG58-34
 50mm SUPERPAVE 19, LEVEL B, PG58-34
 150mm GRANULAR A
 450mm GRANULAR B TYPE II

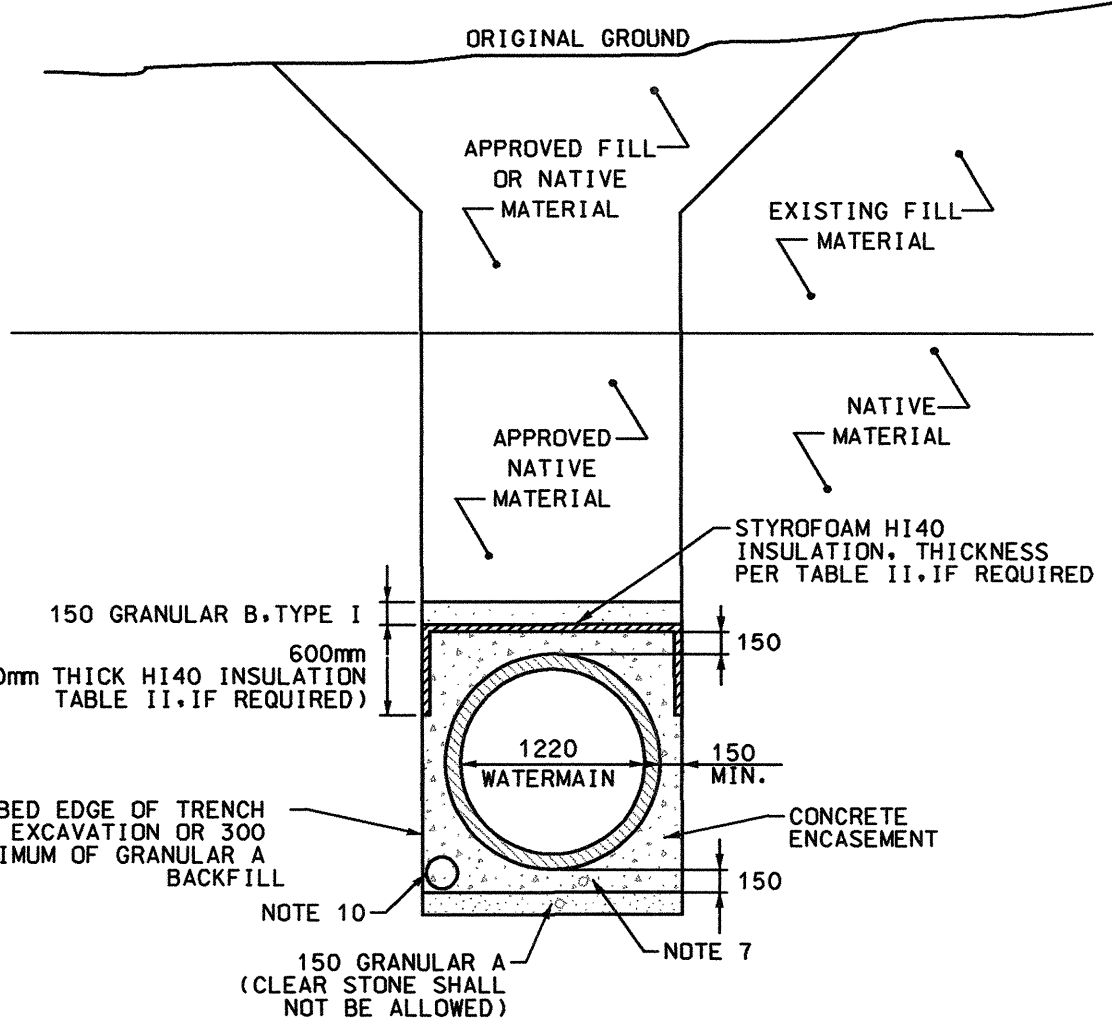

TRENCH DETAIL A
 1220mm WATERMAIN-
 CONCRETE ENCASEMENT
 N. T. S.

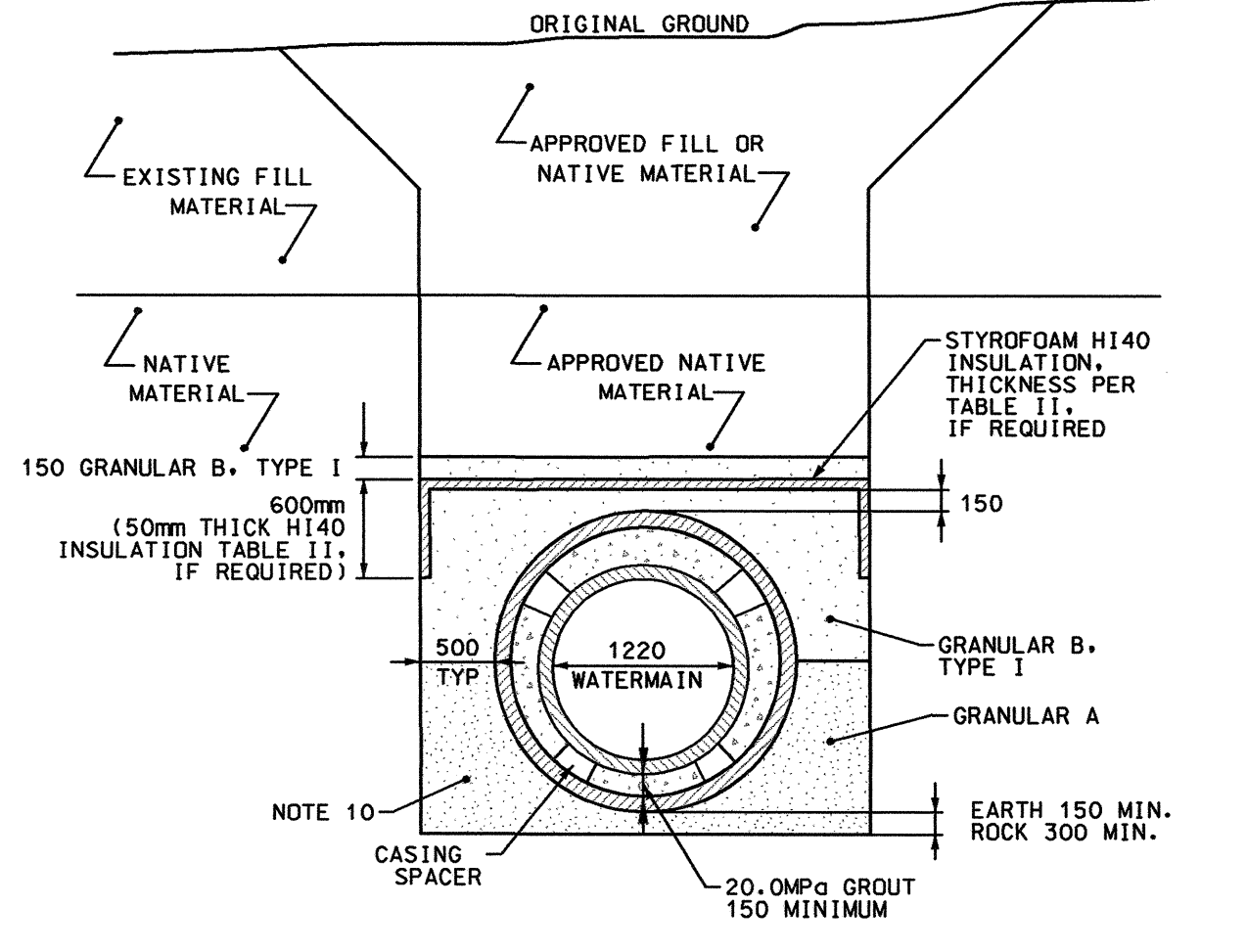

TRENCH DETAIL B
 1220mm WATERMAIN-
 IN CASING
 N. T. S.

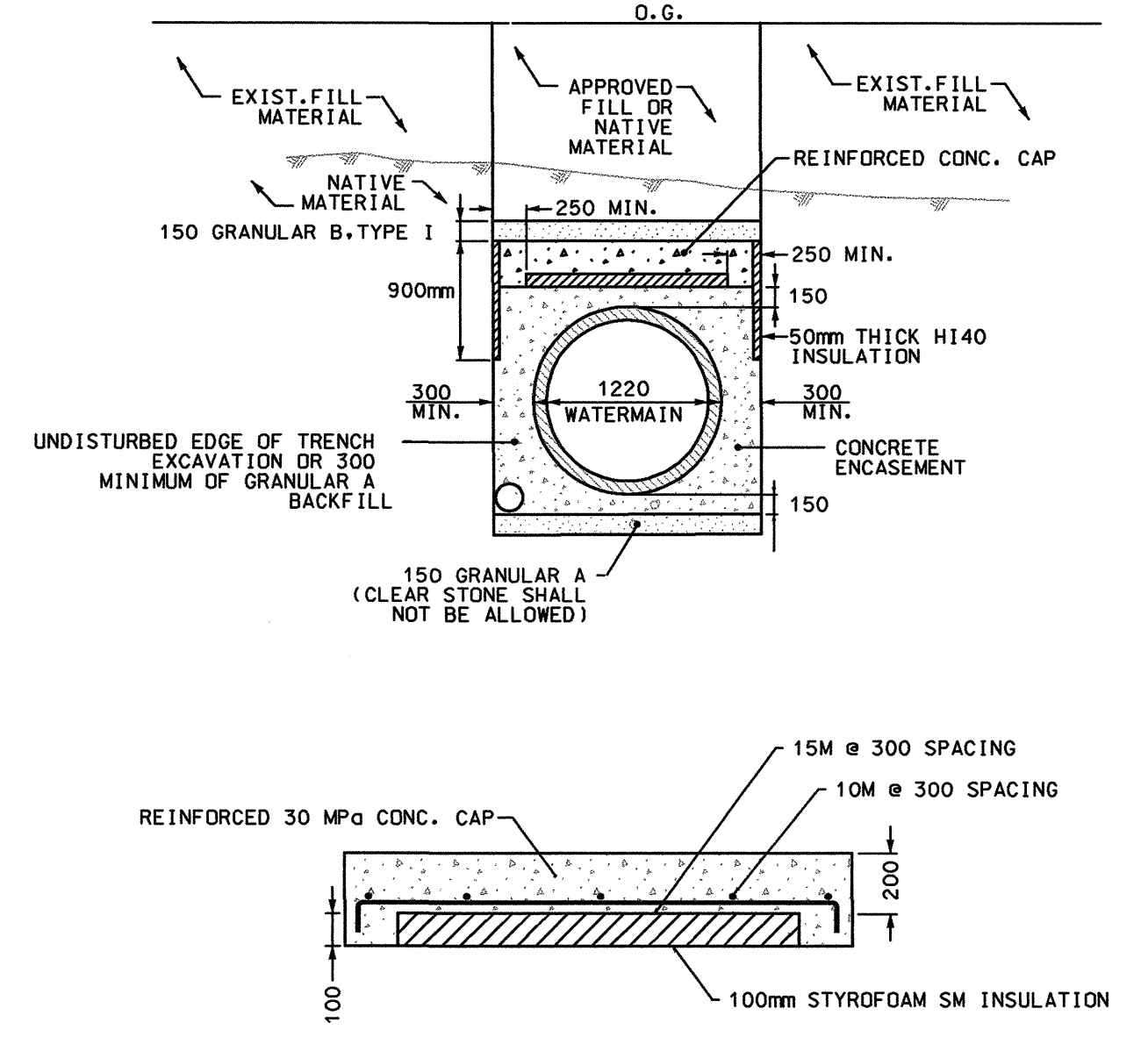

NOTE:

- REINFORCEMENT GRADE 400
- CLEAR COVER TO REINFORCING STEEL - 50mm MINIMUM
- WHERE STYROFOAM SM INSULATION IS SPECIFIED, HI 40 SHALL NOT BE SUBSTITUTED.
- ALL DIMENSIONS IN mm UNLESS OTHERWISE NOTED.

REINFORCED CONCRETE CAP
 STA. 5+840 TO 5+960
 N. T. S.

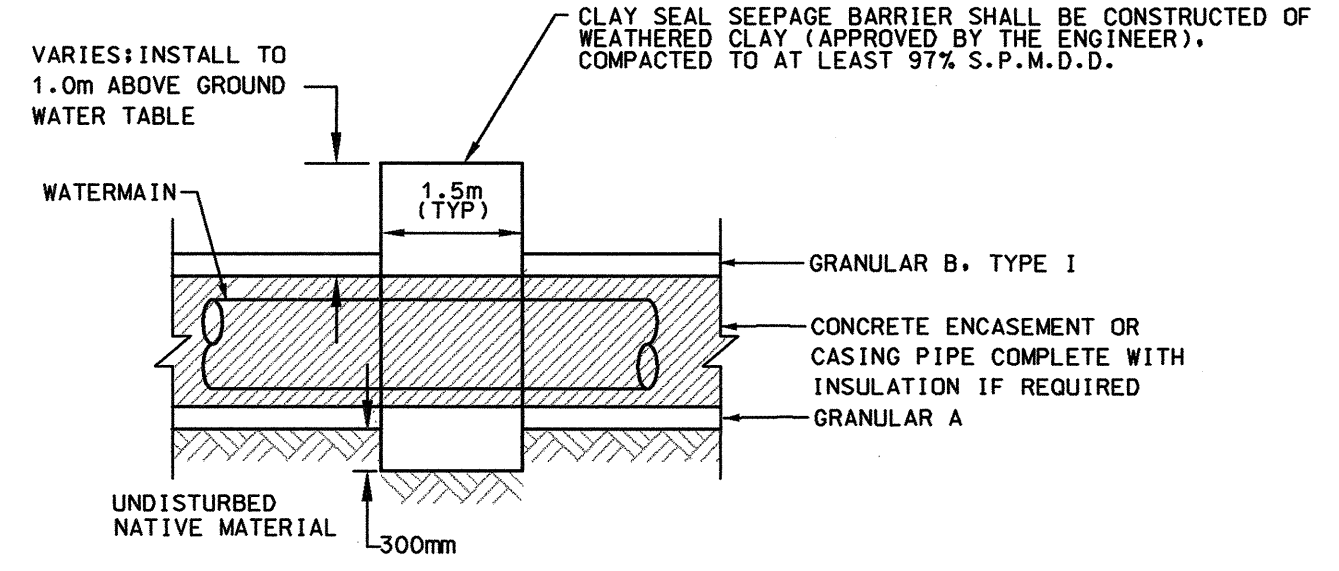

CLAY SEAL SEEPAGE BARRIER
 N. T. S.

NOTES:

- CLAY SEAL SEEPAGE BARRIER SHALL BE KEYED 300MM INTO THE UNDISTURBED TRENCH WALLS.

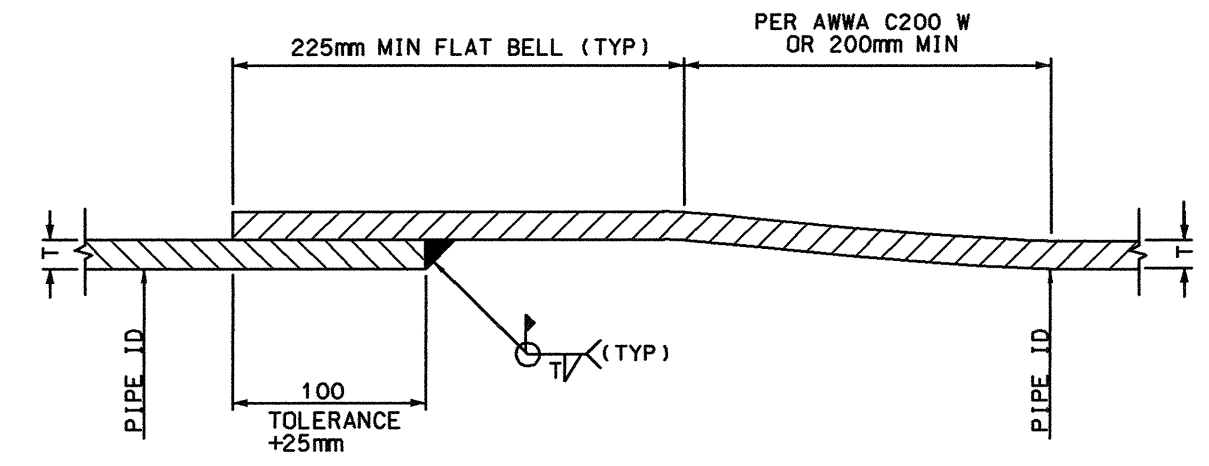

WELDED LAP JOINT (STEEL WATERMAIN)
 N. T. S.

NOTE:

- 1." INDICATES THE THICKNESS OF THE PIPE STEEL PLATE.
- THE CONTRACTOR SHALL RESTRAIN THE STEEL WATERMAIN PIPE WITH A WELDED LAP JOINT OR RESTRAINED COUPLING AS SPECIFIED IN THE CONTRACT DOCUMENTS.
- THE CONTRACTOR SHALL USE EITHER BELL AND SPIGOT GASKETED JOINTS OR WELDED JOINTS.

TRENCH DETAIL NOTES

- 1220mm WATERMAIN SHALL BE STEEL OR CONCRETE PRESSURE PIPE, PER THE SPECIFICATIONS.
- WATERMAIN SHALL BE INSTALLED PER TRENCH DETAIL B AT THE LOCATIONS LISTED IN TABLE I. AT ALL OTHER LOCATIONS THE 1220mm WATERMAIN SHALL CONFORM TO TRENCH DETAIL A OR B.
- TRENCH SHALL CONFORM TO THE GOVERNING HEALTH AND SAFETY REGULATIONS.
- BACKFILL & BEDDING TO BE COMPACTED TO 95% S.P.M.D.D.
- ALL JOINTS WITHIN THE CASING SHALL BE MECHANICALLY RESTRAINED.
- 400mm DIAMETER WATERMAIN AND SMALLER, SEE CITY OF OTTAWA W17 FOR STANDARD TRENCH DETAILS.
- CONCRETE ENCASED WATERMAIN SHALL BE SUPPORTED WITH THE USE OF UNREINFORCED CONCRETE OR CONCRETE BLOCKS. WOOD OR METAL SUPPORTS SHALL NOT BE ALLOWED.
- CASING SPACERS SHALL BE PSI MODEL C12G-2 AS MANUFACTURED BY PIPELINE SEAL AND INSULATOR INC. OR APPROVED EQUAL.
- REFER TO CONTRACT DOCUMENTS FOR FURTHER DETAILS ON THE MANAGEMENT AND DISPOSAL OF EXCAVATED MATERIALS.
- REFER TO CORROSION PROTECTION DETAILS.

| From Sta | To Sta | Comments |
|----------|--------|----------|
| 5+026 | 5+050 | |
| 5+553 | 5+615 | |
| 5+750 | 5+788 | |

| From Sta | To Sta | Thickness (mm) |
|----------|--------|-------------------------|
| 5+825 | 5+840 | 50 |
| 5+840 | 5+960 | REINFORCED CONCRETE CAP |
| 5+960 | 5+980 | 50 |
| 6+025 | 6+041 | 50 |

ISSUED
 DWG. FRAME: 790mm x 534mm RMC-06/91-WG

063018-C21-AB-000 30/08/2010 10:33:48 AM ISSUED FOR ASBUILT

AS-BUILT

RECORD INFORMATION PROVIDED BY CITY OF OTTAWA
 ALL NUMERICAL VALUES THAT ARE NOT STROKED OUT AND REPLACED IN ITALICS ON AS-BUILT DRAWINGS ARE CONSIDERED TO BE DESIGN VALUES ONLY AND NOT MEASURED IN THE FIELD.

**Robinson
 Consultants**

| NO. | REVISIONS | BY | DATE |
|-----|-------------------------|-----|----------|
| 1 | ISSUED FOR TENDER | JDL | 14.02.07 |
| 2 | ISSUED FOR CONSTRUCTION | JDL | 01.06.07 |
| 3 | AS BUILT | DEP | 30.08.10 |
| | | | |
| | | | |

NOTE:
 The location of the utilities is approximate only, the exact location should be determined by consulting the municipal authorities and utility companies concerned.
 The contractor shall prove the location of utilities and shall be responsible for adequate protection from damage

HIGH PRESSURE TRANSMISSION MAIN
 REPLACEMENT PROGRAM
 LEMIEUX ISLAND WATER PURIFICATION PLANT TO
 BRONSON AVENUE

VALVE CHAMBER DETAILS - BRICKHILL

M. J. WILLMETS
 Project Manager

W.R. NEWELL, P.ENG.
 Director Infrastructure Services

B.MASON, P.ENG.
 Manager Construction Services West

Dwn: I.D.M./D.H. Chkd: J.D.L. Des: Chkd:

Ottawa

CONTRACT NO.
ISB06-3018

DWG. NO.
063018-C25

SHEET OF

Date: JUNE 2008

Scale: HORIZONTAL
 0m 0.25 0.5 1.0

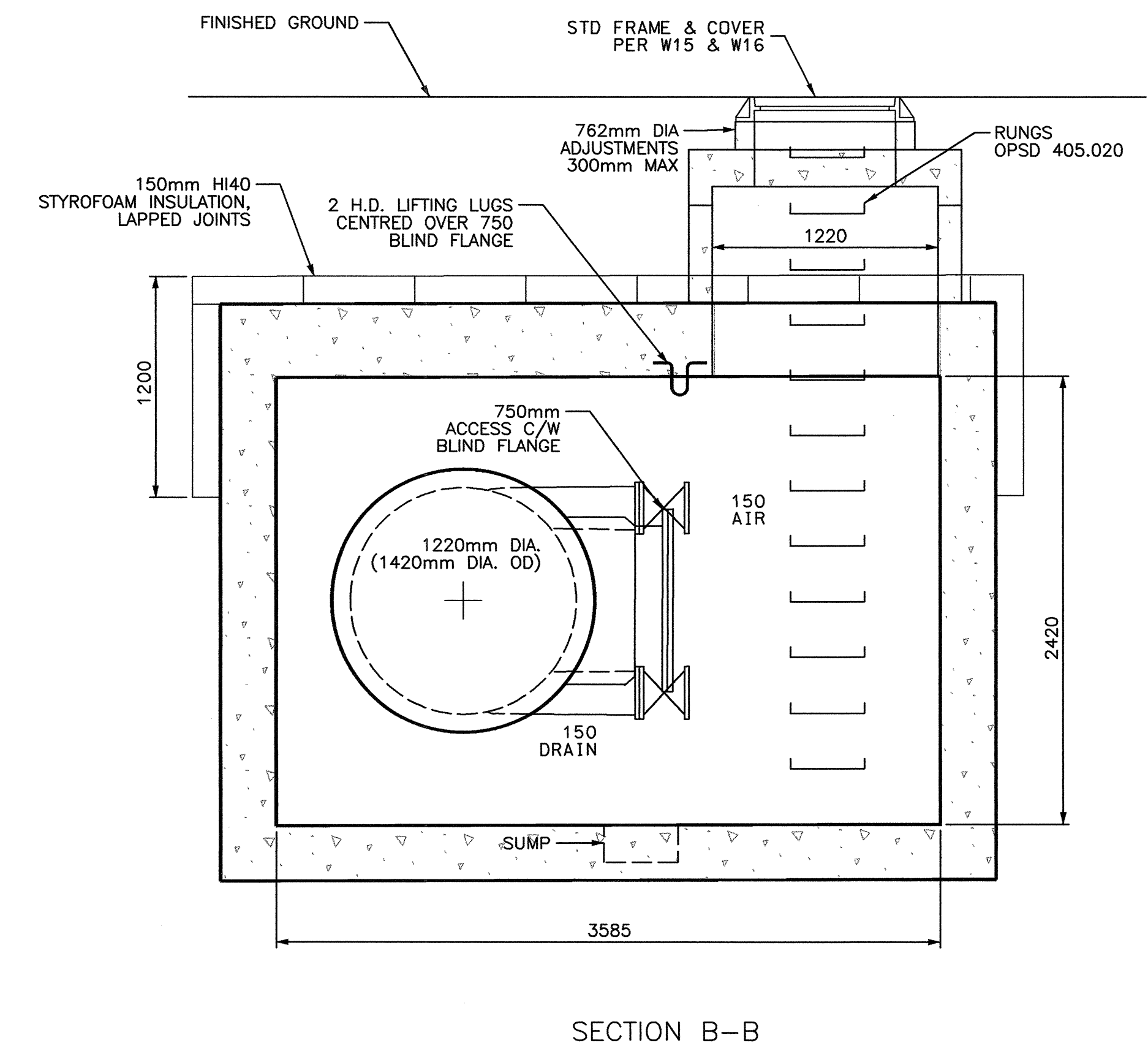
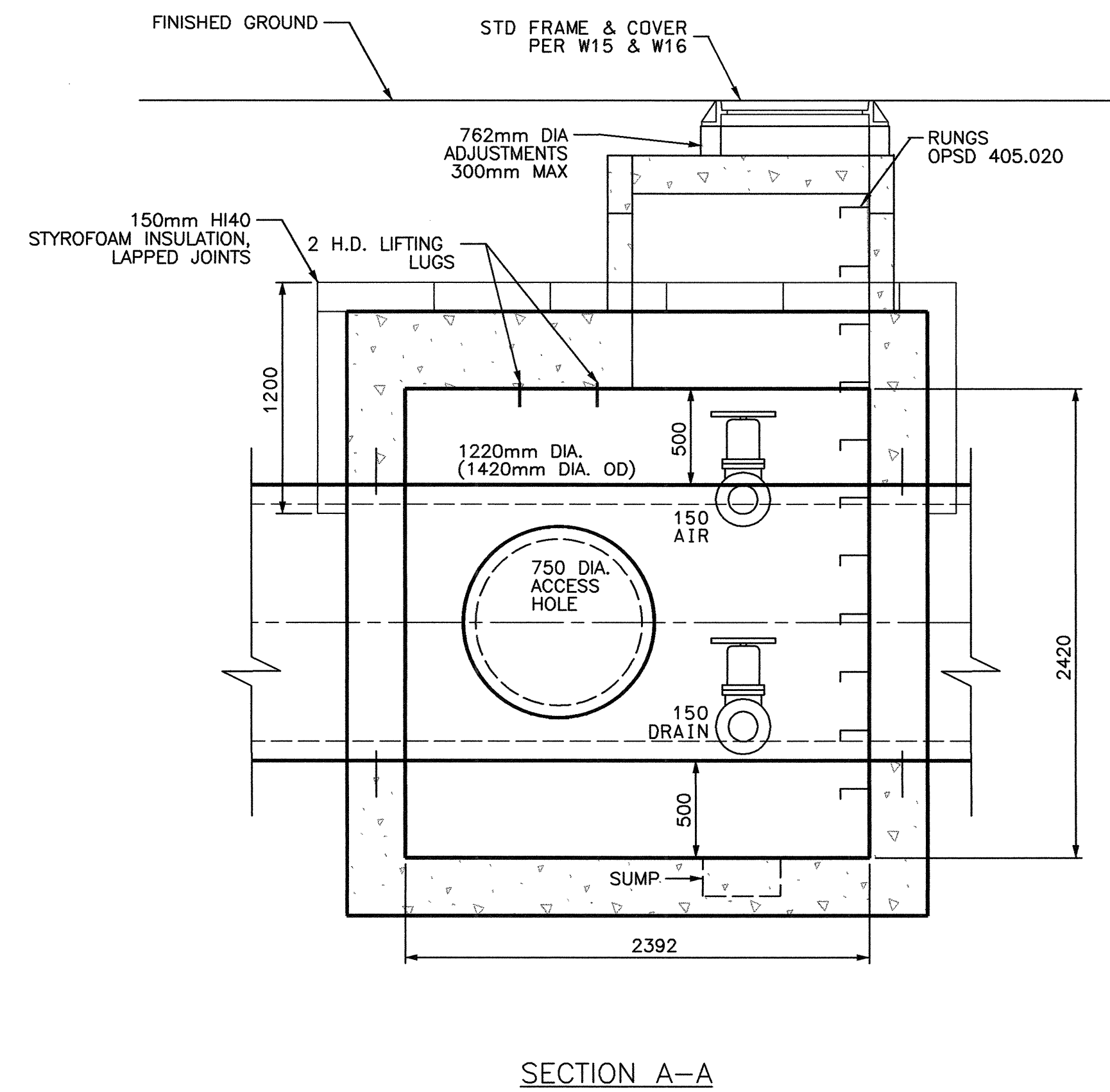
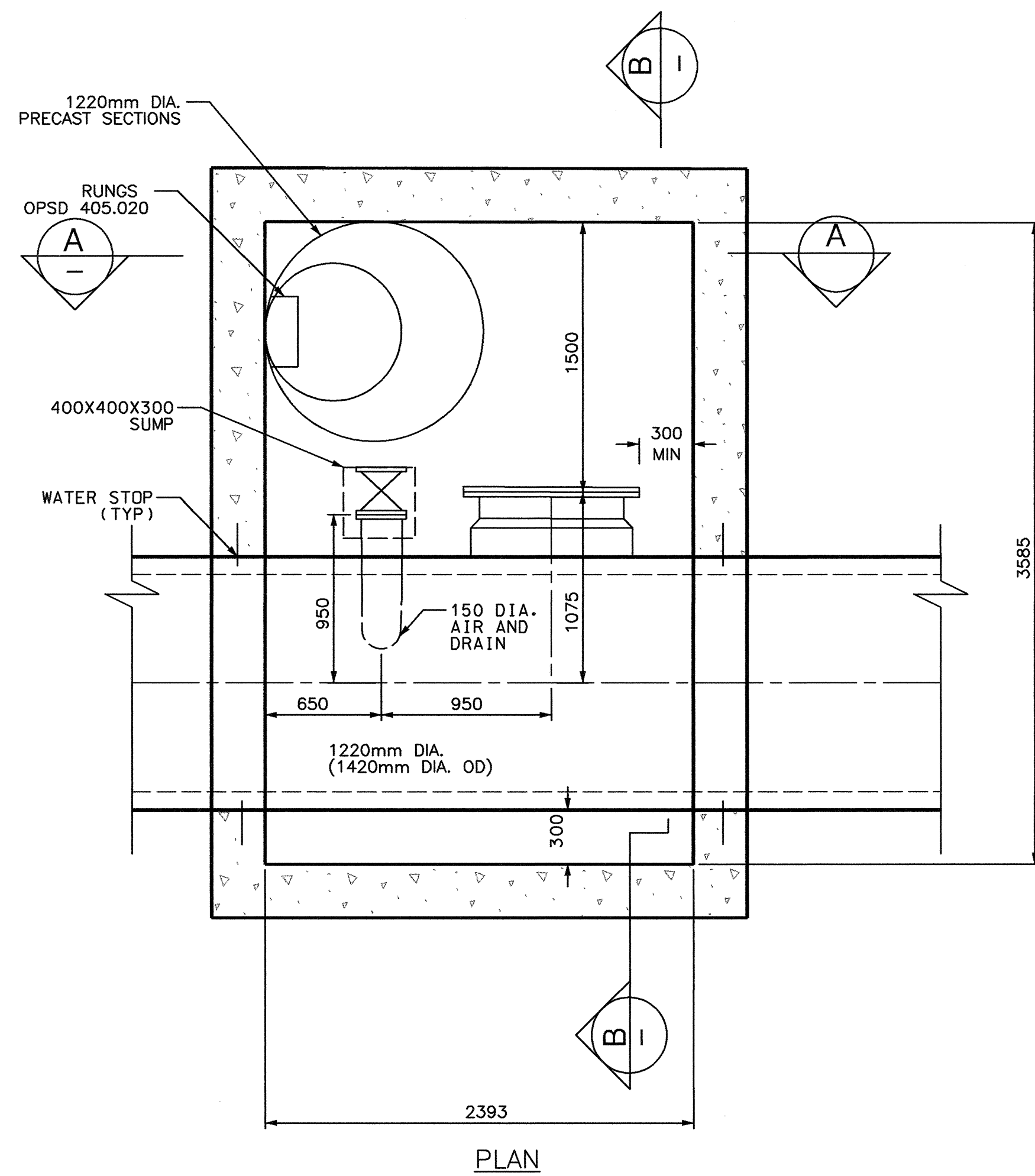

ISSUED

AS-BUILT

RECORD INFORMATION PROVIDED BY CITY OF OTTAWA
 ALL NUMERICAL VALUES THAT ARE NOT STROKED OUT AND REPLACED IN ITALICS ON AS-BUILT DRAWINGS ARE CONSIDERED TO BE DESIGN VALUES ONLY AND NOT MEASURED IN THE FIELD.

**Robinson
 Consultants**

| NO. | REVISIONS | BY | DATE |
|-----|-------------------------|-----|----------|
| 1 | ISSUED FOR TENDER | JDL | 14.02.07 |
| 2 | ISSUED FOR CONSTRUCTION | JDL | 01.06.07 |
| 3 | AS BUILT | DEP | 30.08.10 |

NOTE:
 The location of the utilities is approximate only, the exact location should be determined by consulting the municipal authorities and utility companies concerned.
 The contractor shall prove the location of utilities and shall be responsible for adequate protection from damage

HIGH PRESSURE TRANSMISSION MAIN
 REPLACEMENT PROGRAM
 LEMIEUX ISLAND WATER PURIFICATION PLANT TO
 BRONSON AVENUE

Ottawa
 CONTRACT NO.
ISB06-3018
 DWG. NO.
063018-C26
 SHEET OF
 Date: JUNE 2006
 Scale: HORIZONTAL
 0m 0.25 0.5 1.0

VALVE CHAMBER DETAILS - COMMISSIONER

| | | |
|-----------------------------------|---|---|
| M. J. WILLMETS Project Manager | W. R. NEWELL, P. ENG. Director Infrastructure Services | B. MASON, P. ENG. Manager Construction Services West |
| Dwn: I.D.M./D.H. | Chk: J.D.L. | Des: Crk: |

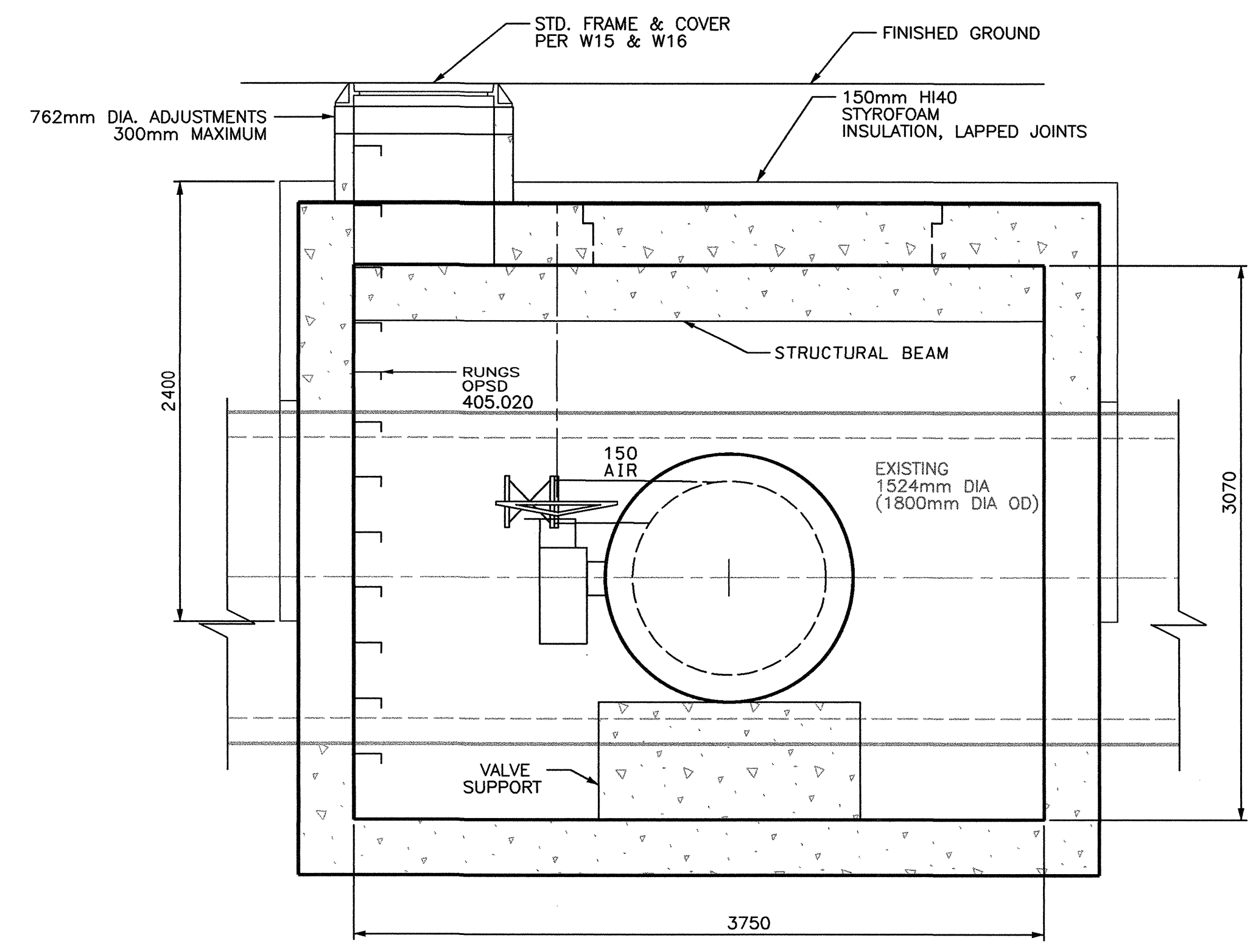
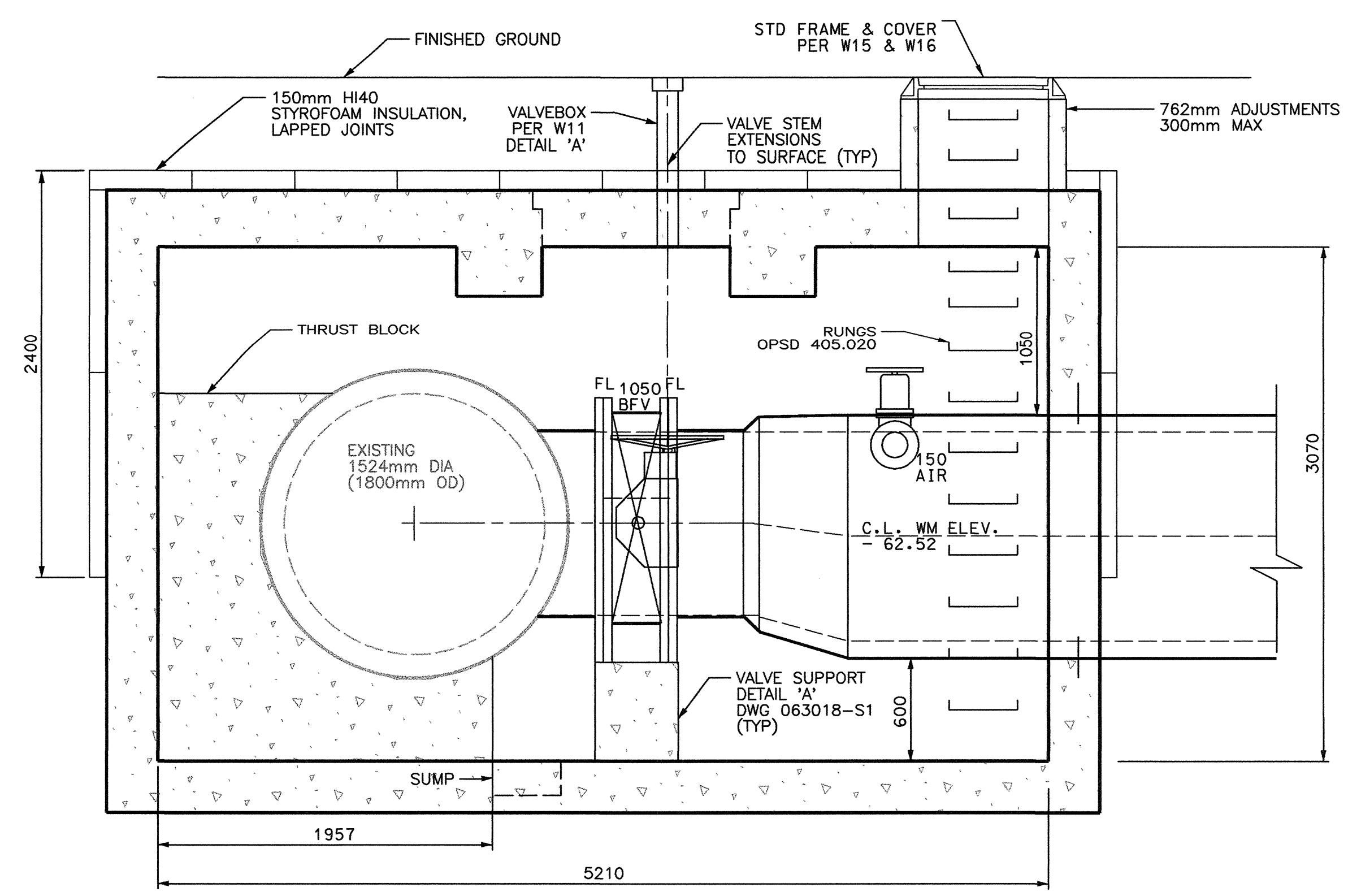
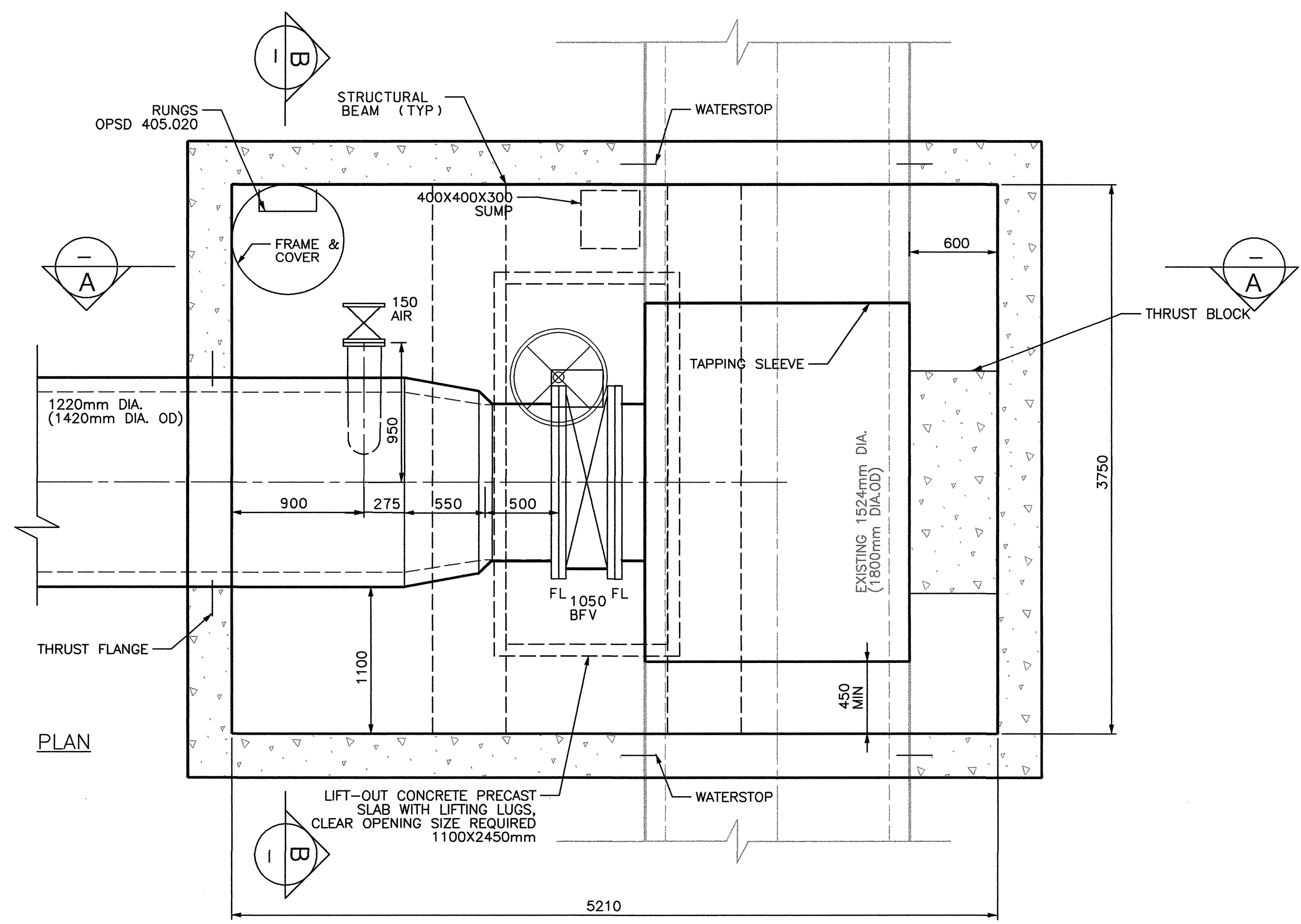

ISSUED

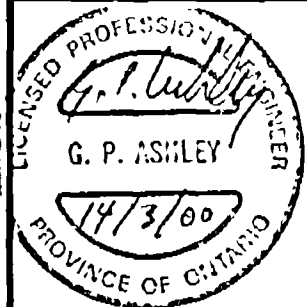

- Notes
- LOCATE AND CONNECT EXISTING SEWER SERVICE FROM 140 BRONSON AVENUE TO NEW 300 SANITARY SEWER ON COMMISSIONER STREET.
 - THE LOCATION OF THE SERVICES/UTILITIES IS APPROXIMATE ONLY, AND MAY BE INCOMPLETE. THE EXACT LOCATIONS SHOULD BE DETERMINED BY CONSULTING THE MUNICIPAL AUTHORITIES AND UTILITIES COMPANIES CONCERNED. THE CONTRACTOR SHALL PROVIDE THE LOCATION OF SERVICES/UTILITIES AND SHALL BE RESPONSIBLE FOR ADEQUATE PROTECTION FROM DAMAGE DURING CONSTRUCTION.
 - CONNECT EXISTING CATCHBASINS TO NEW STORM SEWER USING 250 mm PVC DR 35 PIPE, UNLESS OTHERWISE SHOWN.
 - FLEXIBLE SEWER PIPE EMBEDMENT AND BEDDING IN EARTH PER OPSD 802.010 FLEXIBLE SEWER PIPE EMBEDMENT AND BEDDING IN ROCK PER OPSD 802.013
 - HORIZONTAL AND VERTICAL DEFLECTIONS SHOWN ARE APPROXIMATE ONLY.
 - DETERMINE LIVE WATERMAINS PRIOR TO EXCAVATION. PREVENT LIVE WATERMAINS FROM MOVEMENT DURING EXCAVATION WITH ADEQUATE RESTRAINT, PARTICULARLY OPPOSITE FITTINGS WHERE THERE WILL BE THRUST FORCES ON THE ADJACENT SOIL.

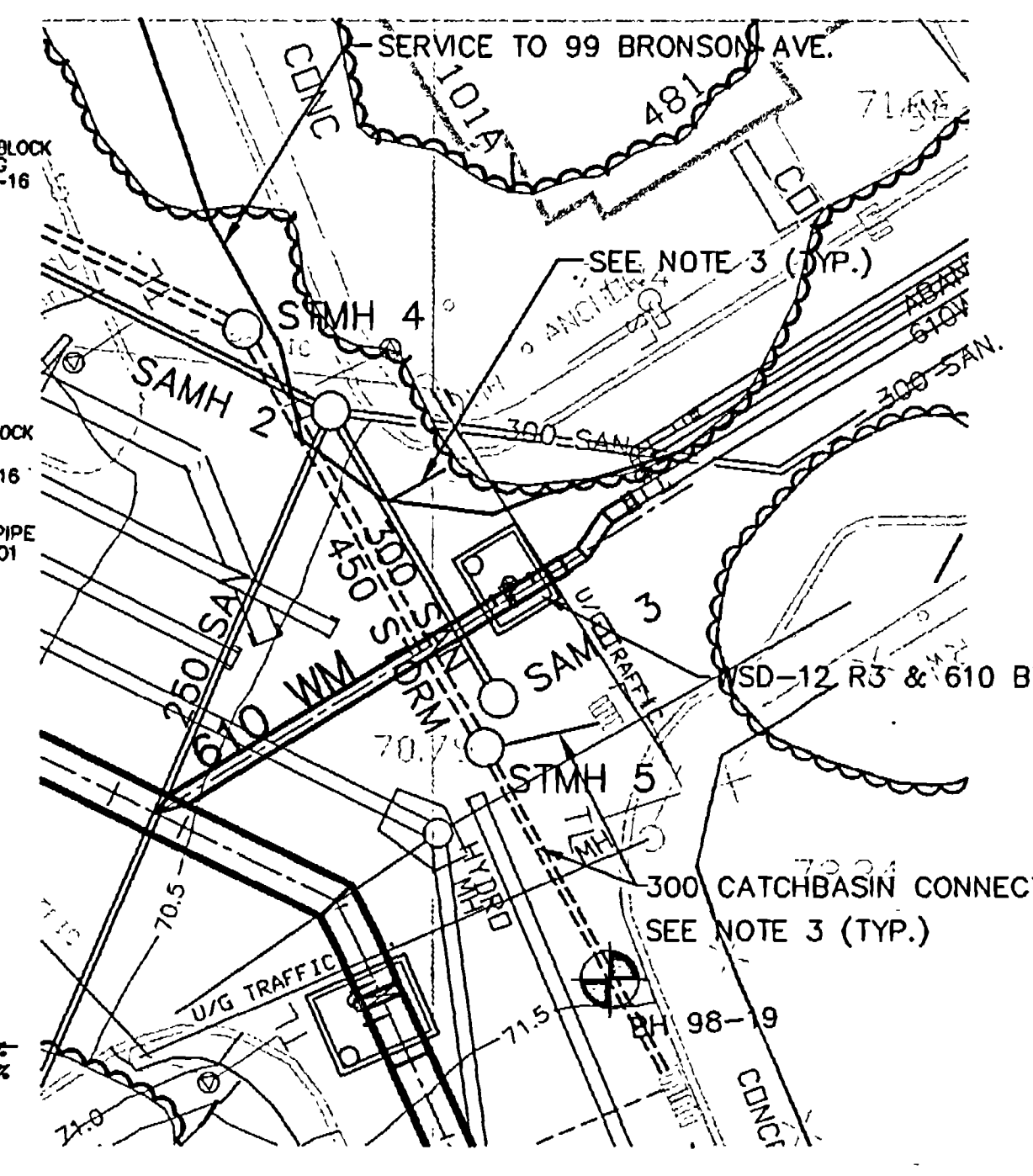
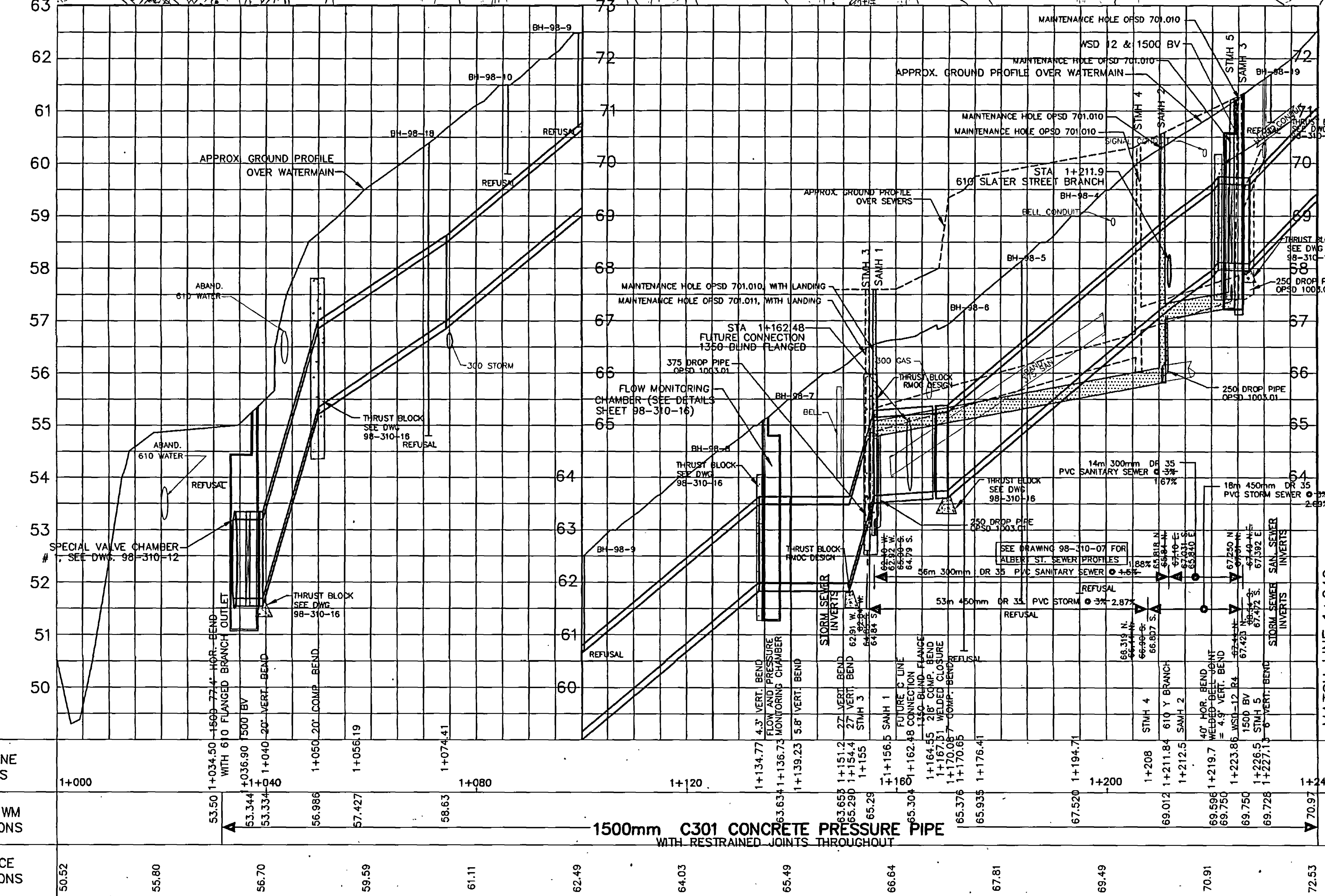
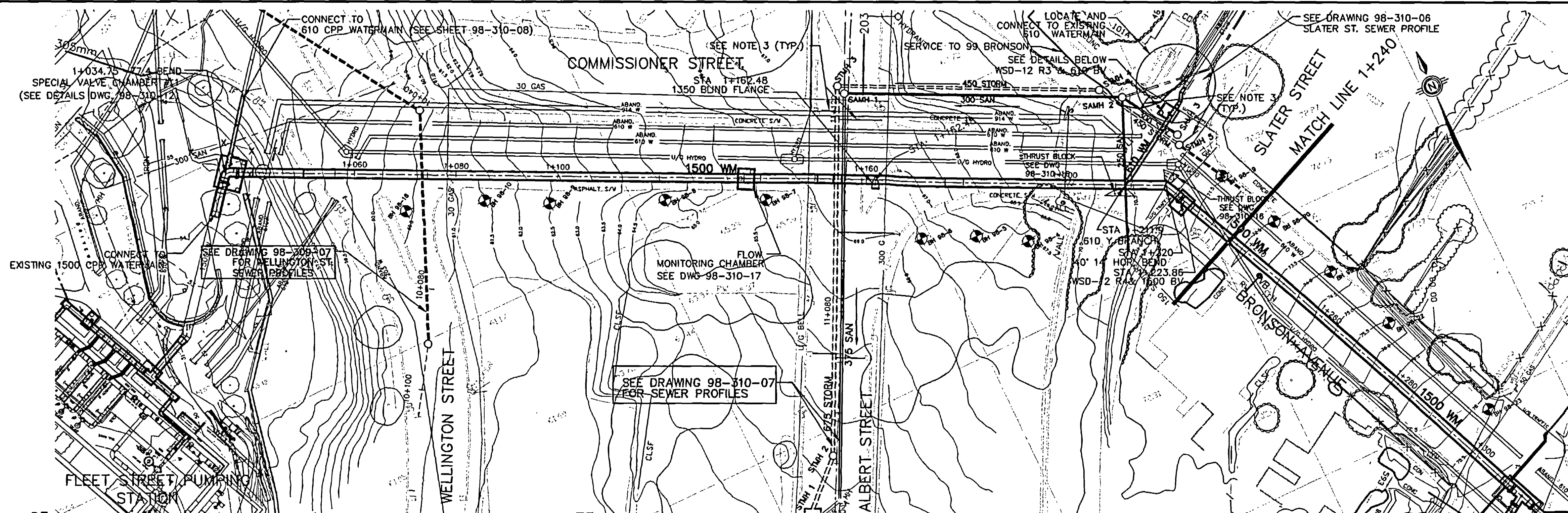

SLATER STREET CONNECTIONS
1:250 HOR.
NOTE: SEE SHEET 98-5137-06 FOR PROFILE AND DETAILS OF CONNECTION TO EXISTING

RECORD DRAWING

RECORD INFORMATION SUPPLIED BY RMO

| | |
|------------------------|----------|
| RECORD DRAWING | 11/01/00 |
| CONSTRUCTION ISSUE | 15/06/99 |
| ADDENDUM NO. 1 | 20/05/99 |
| ISSUED FOR TENDER | 20/04/99 |
| ISSUED FOR CIRCULATION | 04/02/99 |

| No. | Revision | Date |
|-----|----------|------|
| | | |

Scales
1:500 HOR.
1:50 VERT.

Project Title
FLEET STREET PUMPING STATION DISCHARGE PIPING

COMMISSIONER ST. AND BRONSON AVE. WATERMAINS
5326
PLAN AND PROFILE
STA 1+000 TO STA 1+240

| | |
|------------------------|----------------|
| Designed by: R.J.H. | Date: 20/01/99 |
| Drawn by: R.J.H. | Date: 02/02/99 |
| Approved by: G.P.A. | Date: 02/04/99 |
| Drawing No.: 98-310-04 | Rev.No.: 4 |

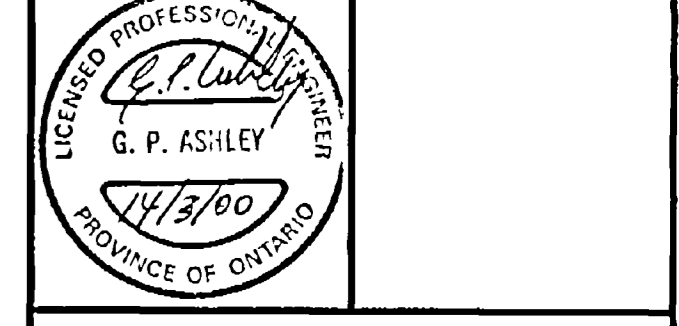

- Notes
1. THE LOCATION OF THE SERVICES/UTILITIES IS APPROXIMATE ONLY, AND MAY BE INCOMPLETE. THE EXACT LOCATIONS SHOULD BE DETERMINED BY CONSULTING THE MUNICIPAL AUTHORITIES AND UTILITIES COMPANIES CONCERNED. THE CONTRACTOR SHALL PROVIDE THE LOCATION OF SERVICES/UTILITIES AND SHALL BE RESPONSIBLE FOR ADEQUATE PROTECTION FROM DAMAGE DURING CONSTRUCTION.
 2. FLEXIBLE SEWER PIPE EMBEDMENT AND BEDDING IN EARTH PER OPSD 802.010
FLEXIBLE SEWER PIPE EMBEDMENT AND BEDDING IN ROCK PER OPSD 802.013
 3. CONNECT EXISTING CATCHBASINS TO NEW STORM SEWER USING 250mm DR 35 PVC STORM SEWER PIPE UNLESS OTHERWISE SHOWN.
 4. HORIZONTAL AND VERTICAL DEFLECTIONS SHOWN ARE APPROXIMATE ONLY.
 5. WOOD WALL FLOW CONTROL PER CITY OF OTTAWA DETAIL S19 MODIFIED TO FIT OVER TOP PART OF 675 OPENING ON OUTLET OF MAINTENANCE HOLE PROVIDING 230mm CLEARANCE TO INVERT.
 6. DETERMINE LIVE WATERMANS PRIOR TO EXCAVATION. PREVENT LIVE WATERMANS FROM MOVEMENT DURING EXCAVATION WITH ADEQUATE RESTRAINT, PARTICULARLY OPPOSITE FITTINGS WHERE THERE WILL BE THRUST FORCES ON THE ADJACENT SOIL.

RECORD DRAWING

| RECORD INFORMATION SUPPLIED BY RMOC | | |
|-------------------------------------|-----|----------|
| RECORD DRAWING | | 11/01/00 |
| CONSTRUCTION ISSUE | 4 | 15/06/99 |
| REVISED SANITARY SEWER SIZE | (3) | 28/05/99 |
| ADDENDUM NO. 1 | (2) | 20/05/99 |
| ISSUED FOR TENDER | 1 | 20/04/99 |

Scales
1:500 HOR.
1:50 VERT.

Project Title
FLEET STREET PUMPING STATION DISCHARGE PIPING
5326
COMMISSIONER ST. AND BRONSON AVE. WATERMANS

PLAN AND PROFILE LAURIER AVE. CONNECTIONS
WELLINGTON ST. STORM SEWER
ALBERT ST. SEWERS

Designed by: P.J.H. Date 20/01/99
Drawn by: P.J.H. Date 18/03/99
Approved by: GPA Date 02/04/99
Drawing No.: 98-310-07 Rev.No.: 4

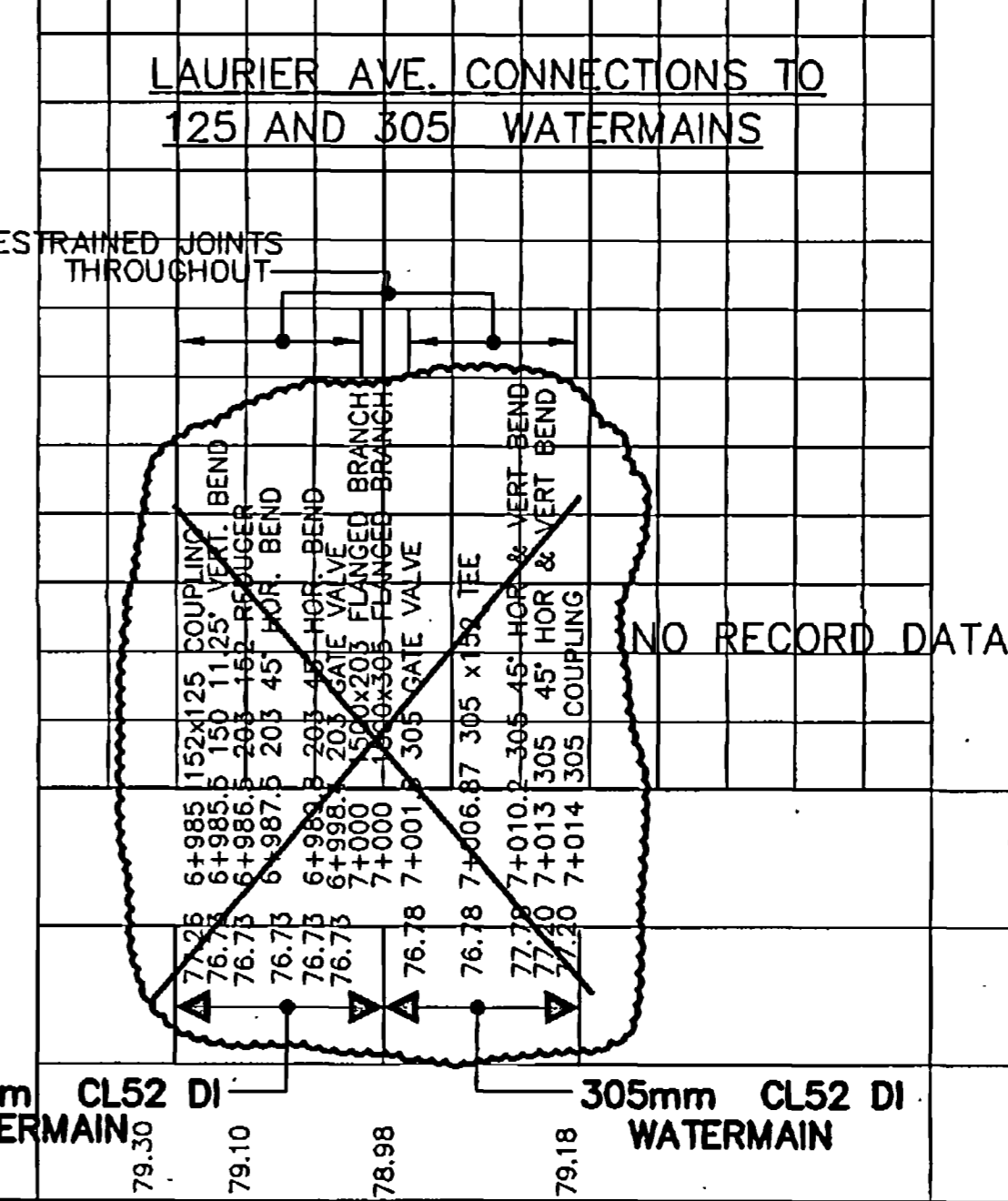
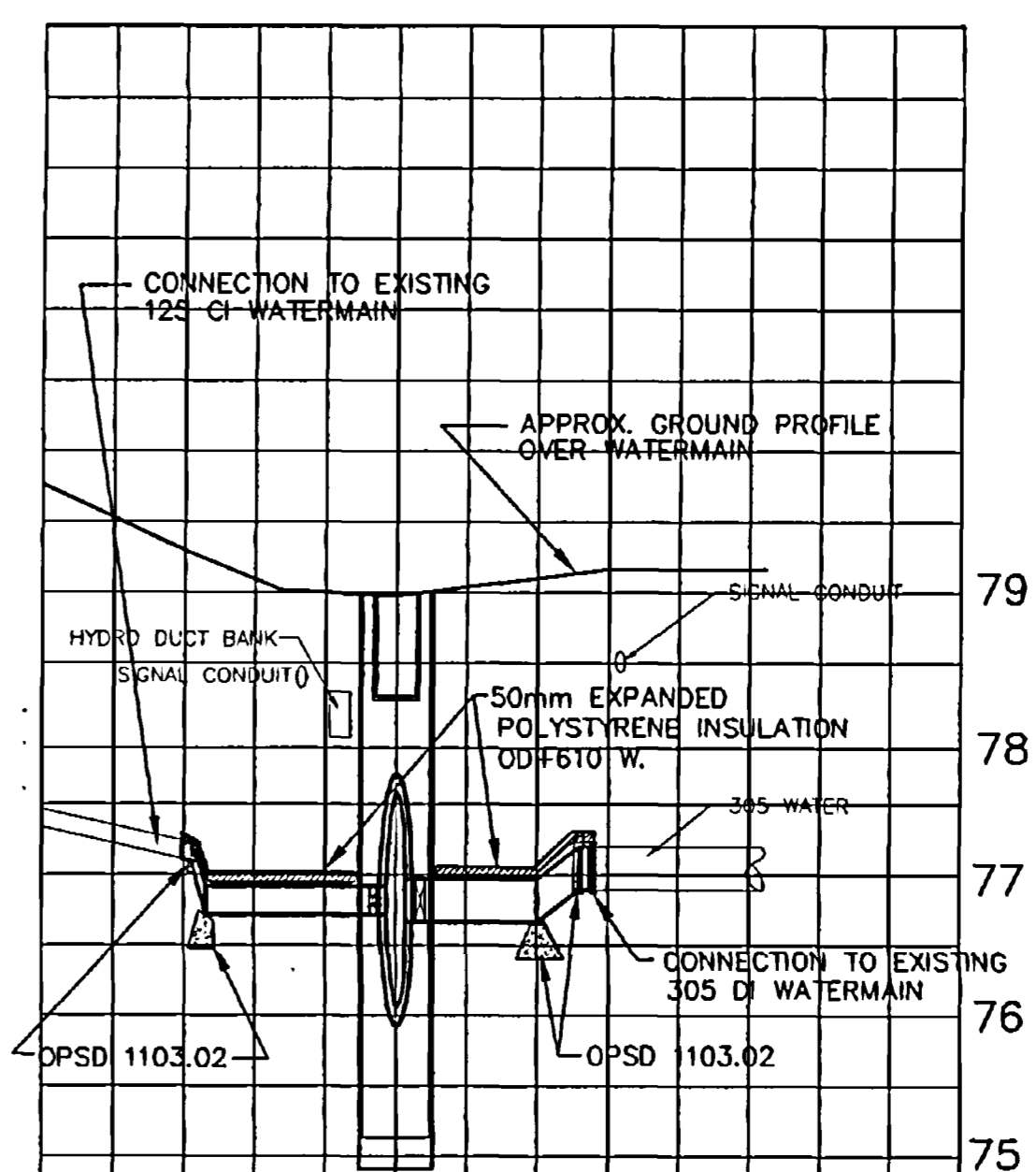
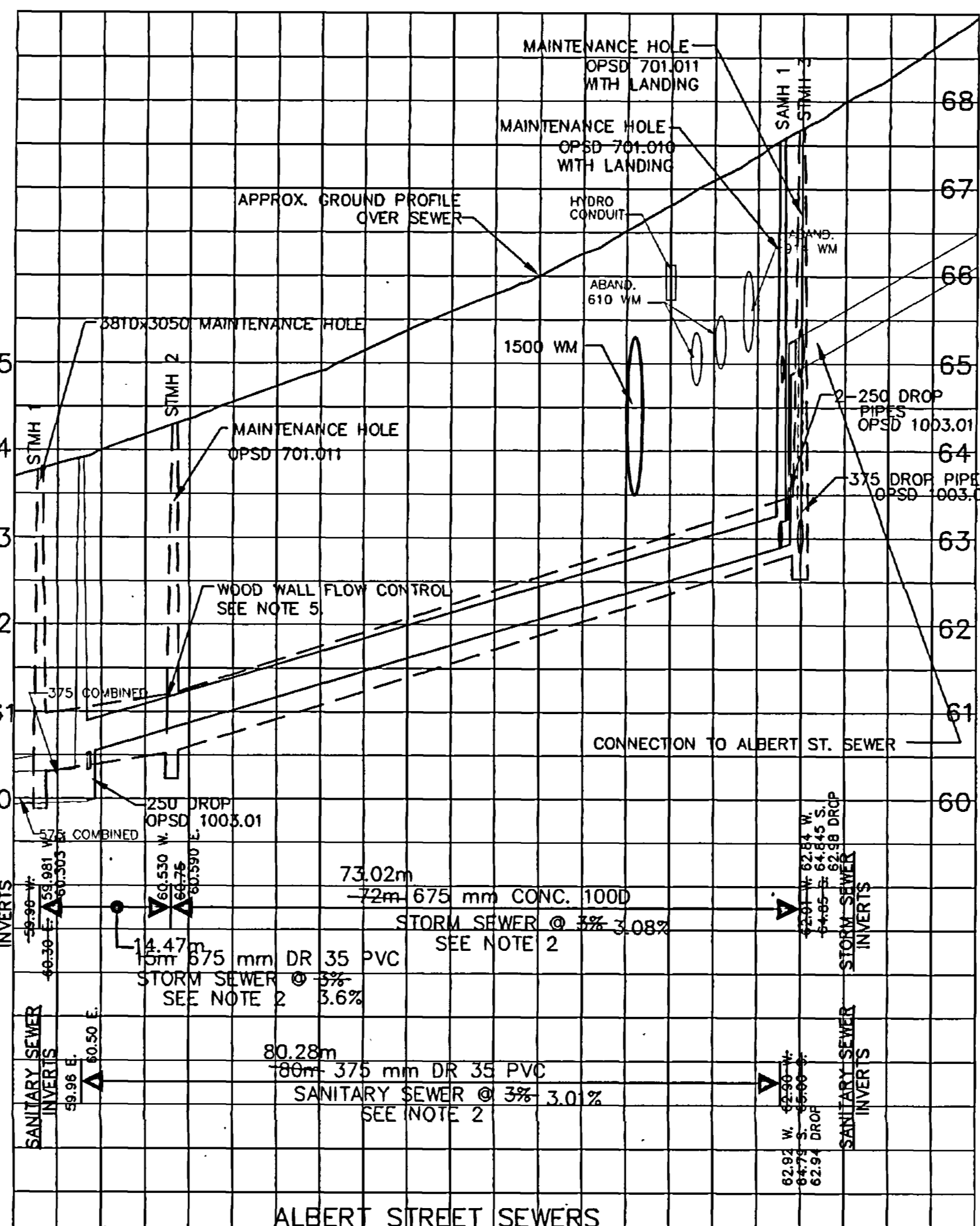
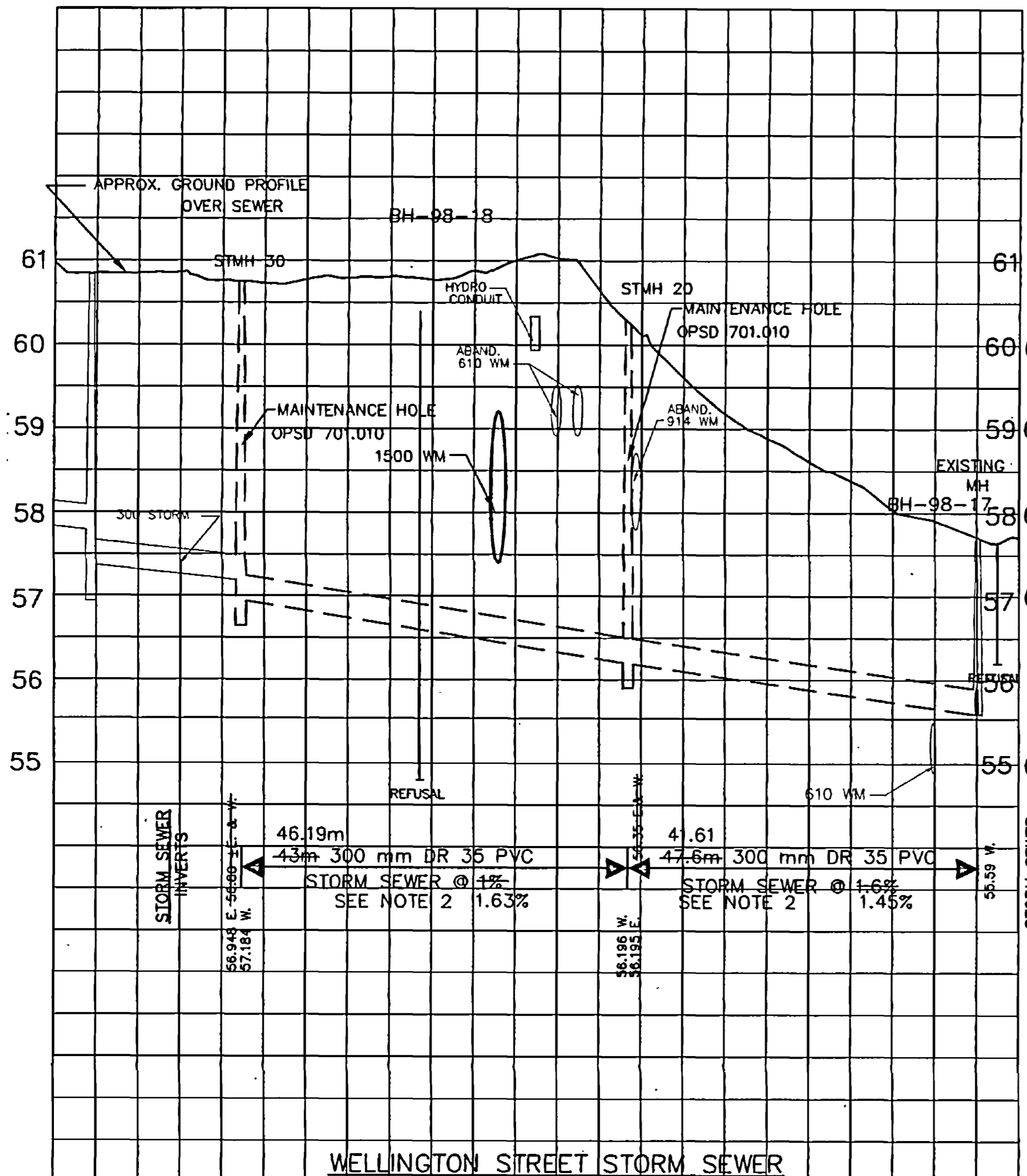
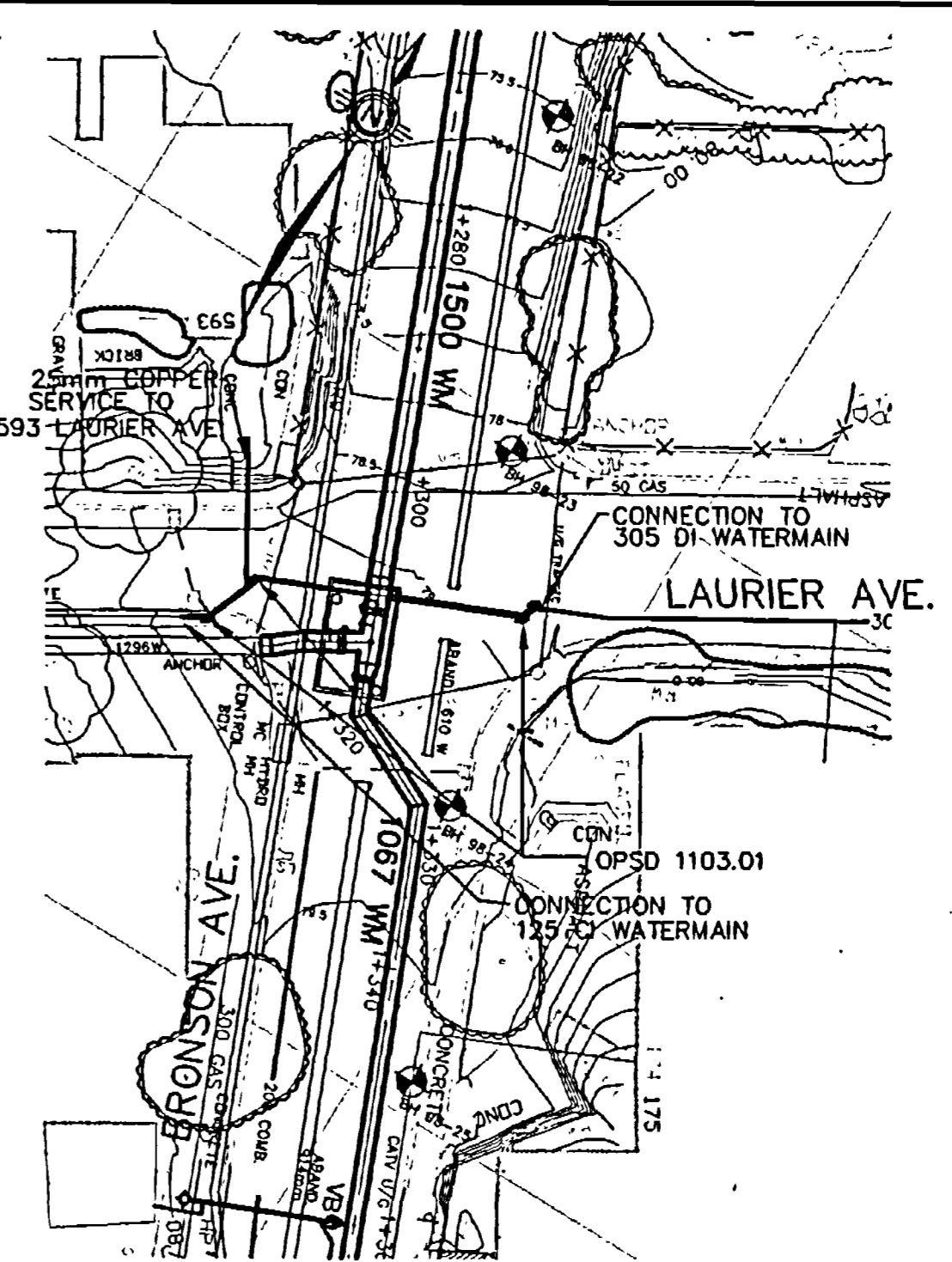
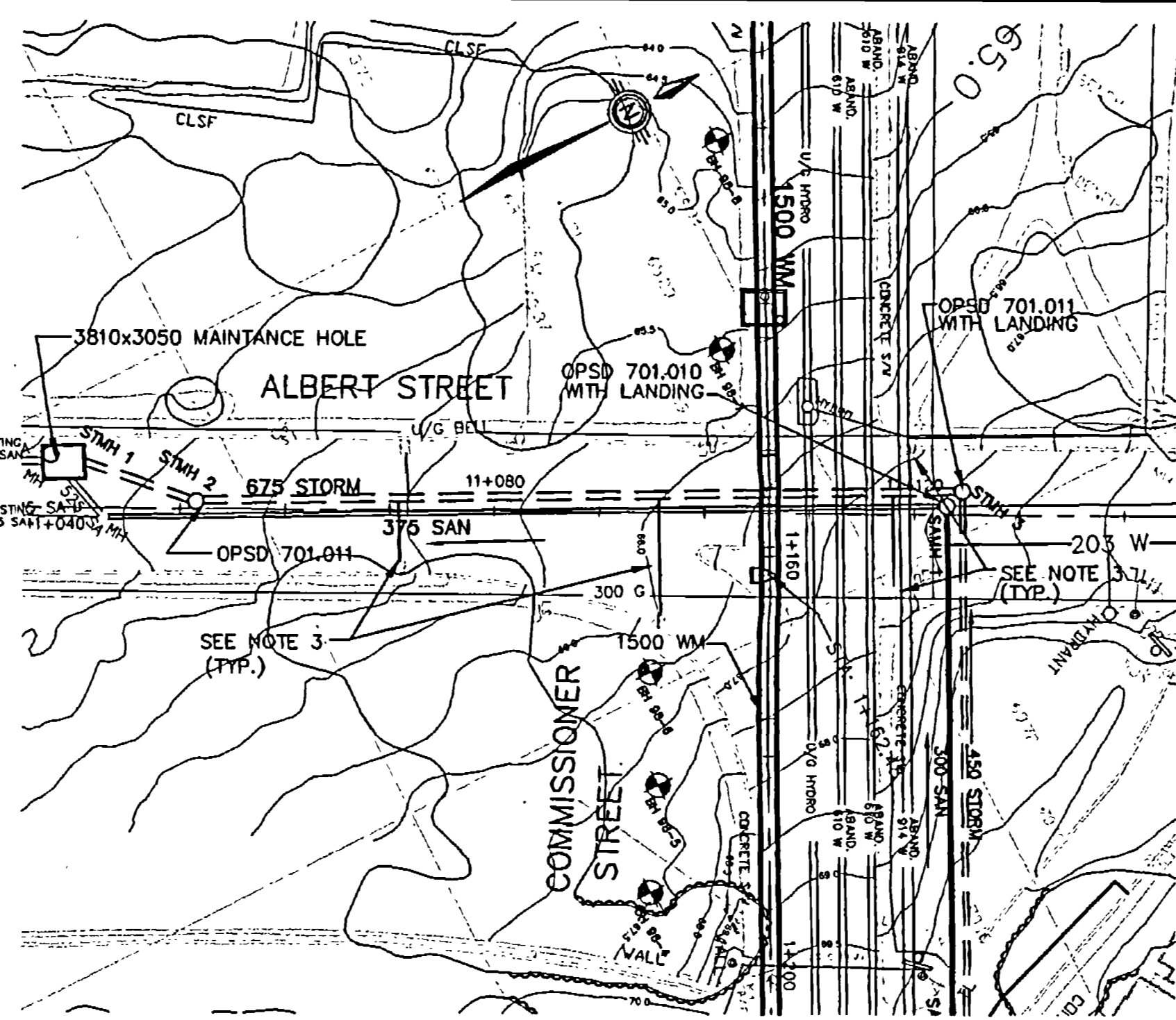
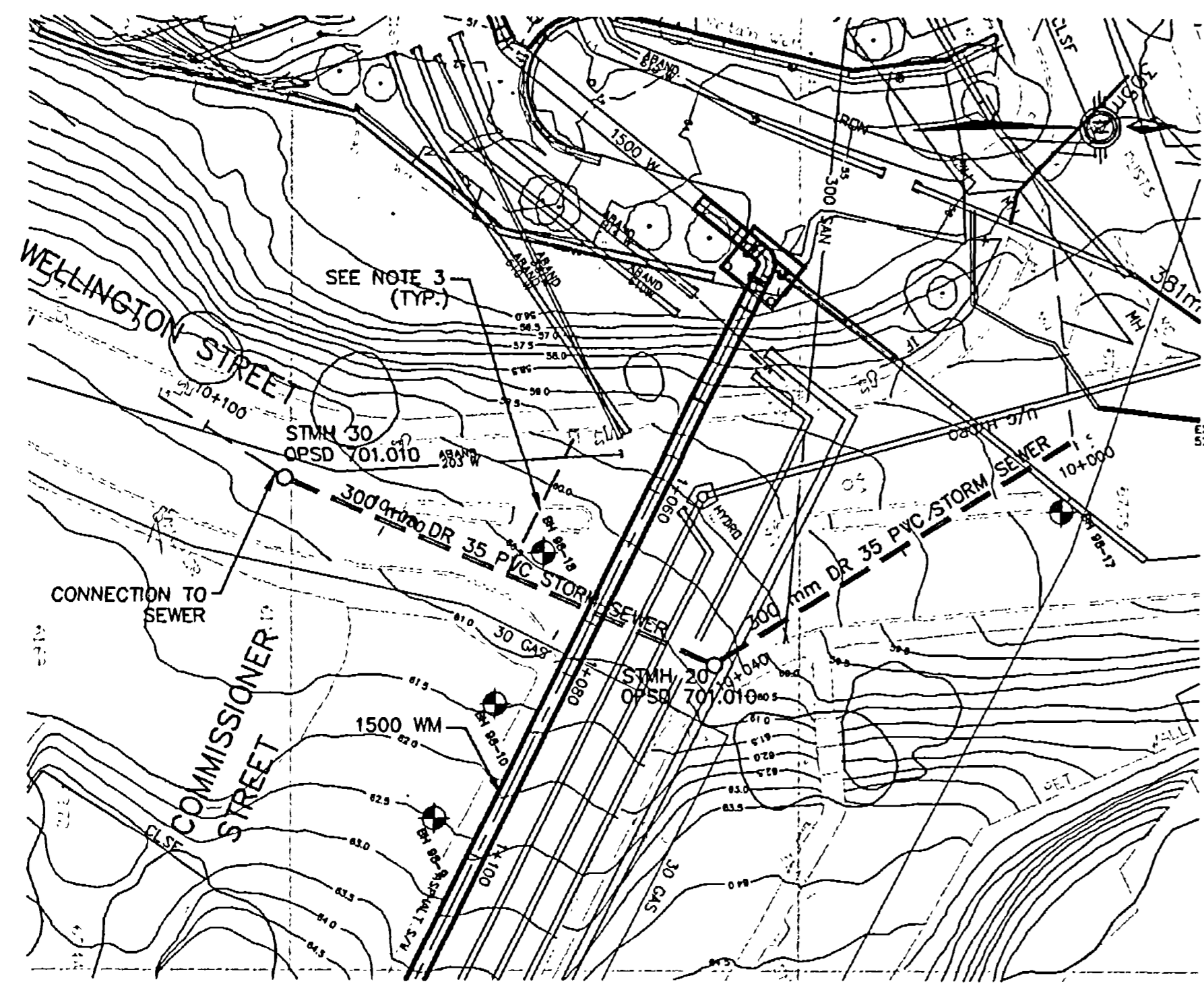

FILE NAME: E02181\LOK\CAD\9831007.dwg

| CENTERLINE STATIONS | SURFACE ELEVATIONS |
|--------------------------------------|----------------------------------|
| STMH 30 +087.8 10+080 | 60.99 60.85 60.75 60.78 |
| STMH 20 +041.61 10+040 | 60.88 61.00 60.12 |
| +000 EXISTING ST. MA 10+000 | 58.61 57.71 |

| CENTERLINE STATIONS | SURFACE ELEVATIONS |
|---------------------------------------|-------------------------|
| +036 EXISTING SAN. MH 10+040 | 63.78 63.84 63.91 |
| +052.5 STMH 2 10+080 | 64.25 64.56 |
| +123 STMH 1 10+120 | 67.15 67.38 |
| +124.5 STMH 3 10+120 | 67.65 |
| 203mm CL52 DI WATERMAIN | 68.61 |
| 305mm CL52 DI WATERMAIN | 79.10 79.18 79.18 |

RECORD DRAWING

RECORD INFORMATION SUPPLIED BY RMOC

| No. | Revision | Date |
|-----|--------------------|----------|
| | RECORD DRAWING | 11/01/00 |
| 3 | CONSTRUCTION ISSUE | 15/06/99 |
| (2) | ADDENDUM NO. 1 | 20/05/99 |
| 1 | ISSUED FOR TENDER | 20/04/99 |

Scales
AS SHOWN

Project Title
FLEET STREET PUMPING STATION DISCHARGE PIPING
COMMISSIONER ST. AND BRONSON AVE. WATERMAINS

5326
SPECIAL VALVE CHAMBER DETAILS I

| | |
|------------------------|----------------|
| Designed by: DEM | Date: 15/02/99 |
| Drawn by: KRS | Date: 15/02/99 |
| Approved by: GPA | Date: 19/04/99 |
| Drawing No.: 98-310-12 | Rev.No.: 3 |

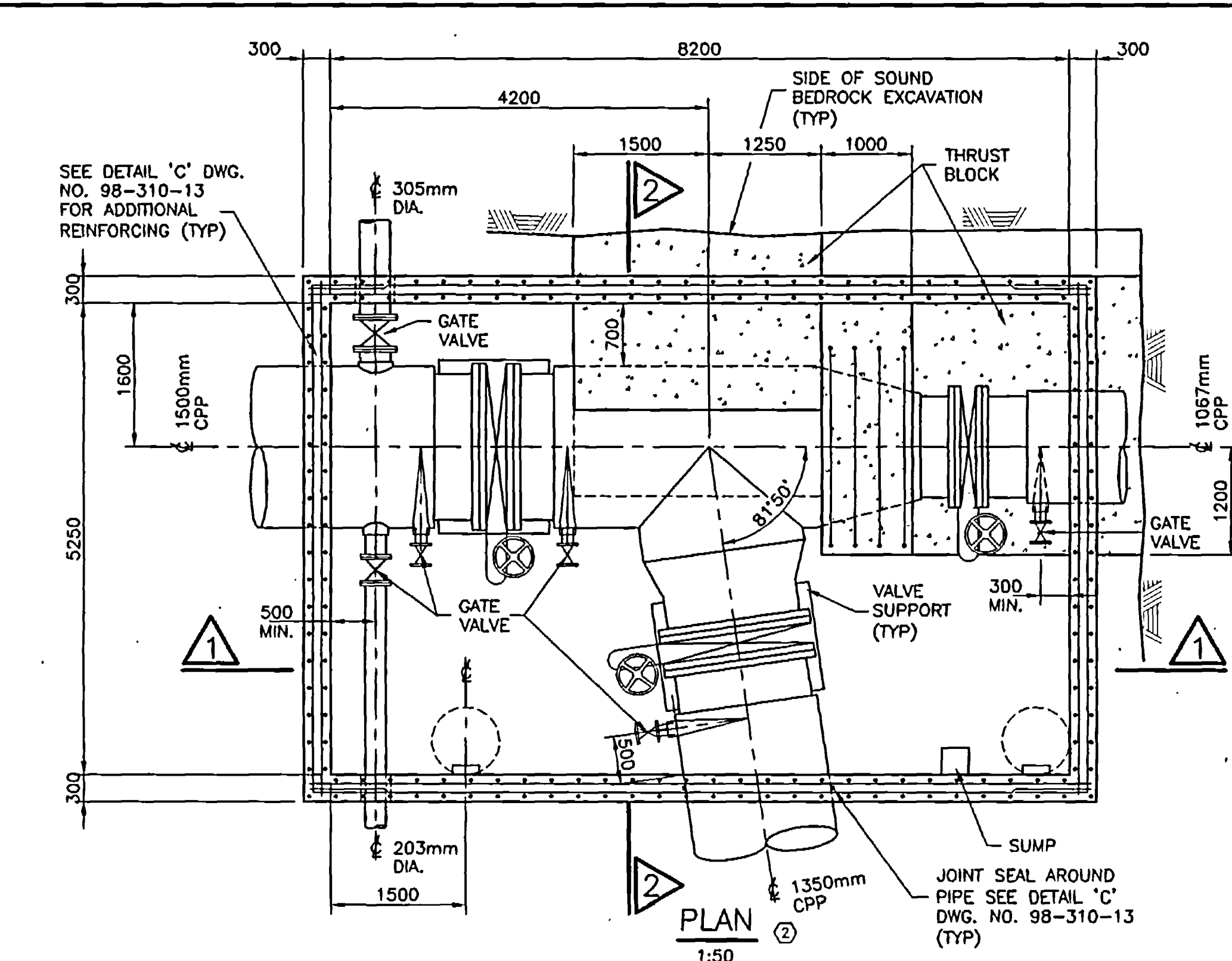
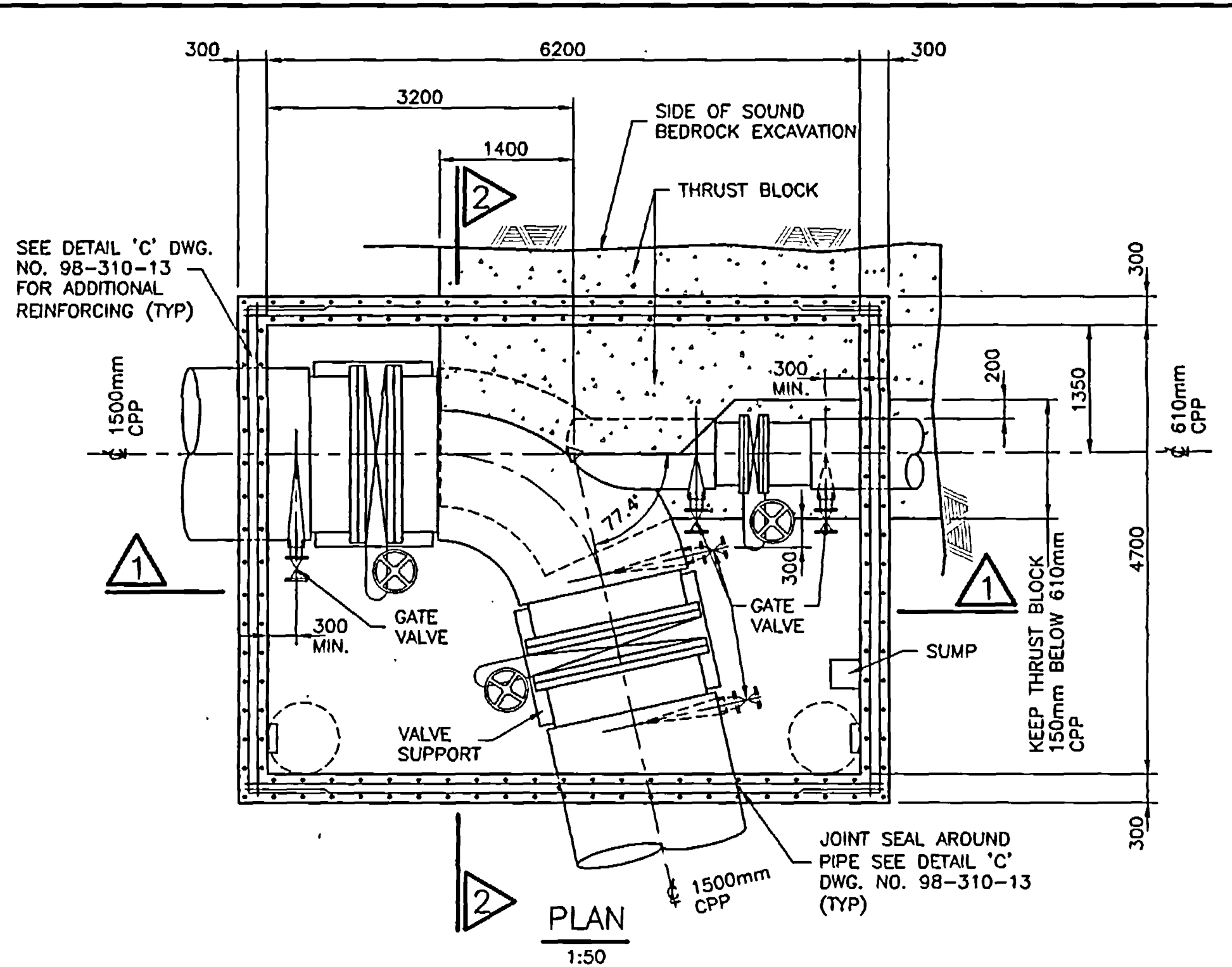

- GENERAL NOTES - STRUCTURES:**
- CLASS OF CONCRETE:
CHAMBERS, WALLS & SLABS 30 MPa
THRUST BLOCKS/PIPE SUPPORTS 20 MPa
PRECAST WALL CAP 35 MPa
MASS CONCRETE 20 MPa
REMAINDER 30 MPa
 - CLEAR COVER TO REINFORCING STEEL:
EXTERIOR FORMED SURFACE 70 +/- 20 mm
INTERIOR FORMED SURFACES 50 +/- 10 mm
CAST AGAINST ROCK OR SOIL 100 +/- 25 mm
 - REINFORCING STEEL SHALL BE GRADE 400 UNLESS OTHERWISE SPECIFIED.
 - ALL DIMENSIONS ARE IN MILLIMETRES. STATIONS AND ELEVATIONS ARE SHOWN IN METRES UNLESS NOTED OTHERWISE.
 - THE CONTRACTOR SHALL VERIFY ALL RELEVANT DIMENSIONS, ELEVATIONS, AND DETAILS OF THE EXISTING WORK ON SITE AND REPORT ANY DISCREPANCIES TO THE CONTRACT ADMINISTRATOR BEFORE PROCEEDING WITH THE WORK.
 - CHAMFER ALL EXPOSED CONCRETE EDGES 20mm x 20mm UNLESS NOTED.
 - SAW CUTS IN CONCRETE, WHERE DESIGNATED, SHALL BE 25mm DEEP OR TO THE FIRST LAYER OF REINFORCING STEEL, WHICHEVER IS LESS.
 - GRANULAR AND SELECT NATIVE BACKFILL SHALL BE COMPACTED TO MINIMUM 95% STANDARD PROCTOR DENSITY.
- NOTES:**
FOR NOTES - SPECIAL CHAMBERS SEE DWG. 98-310-13.

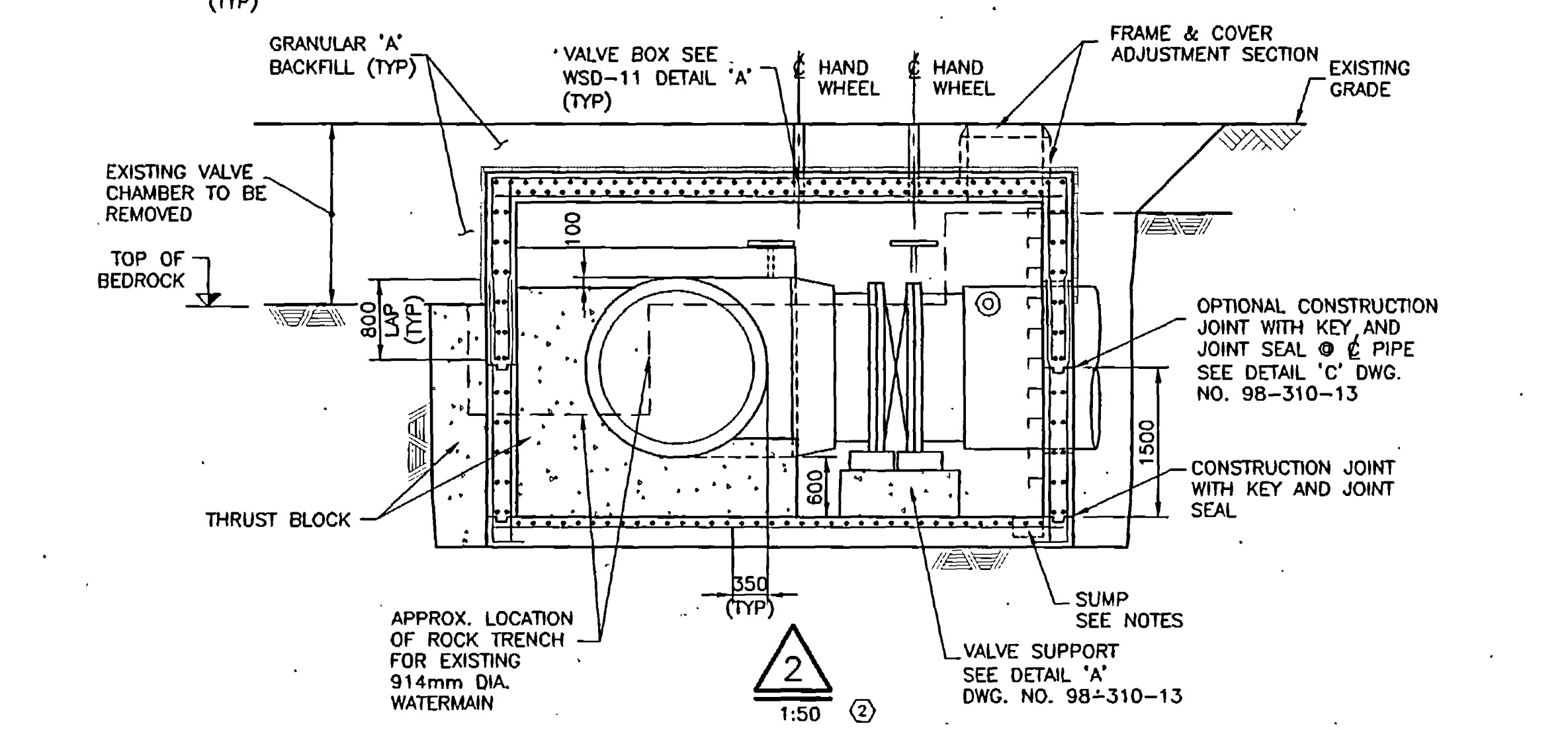
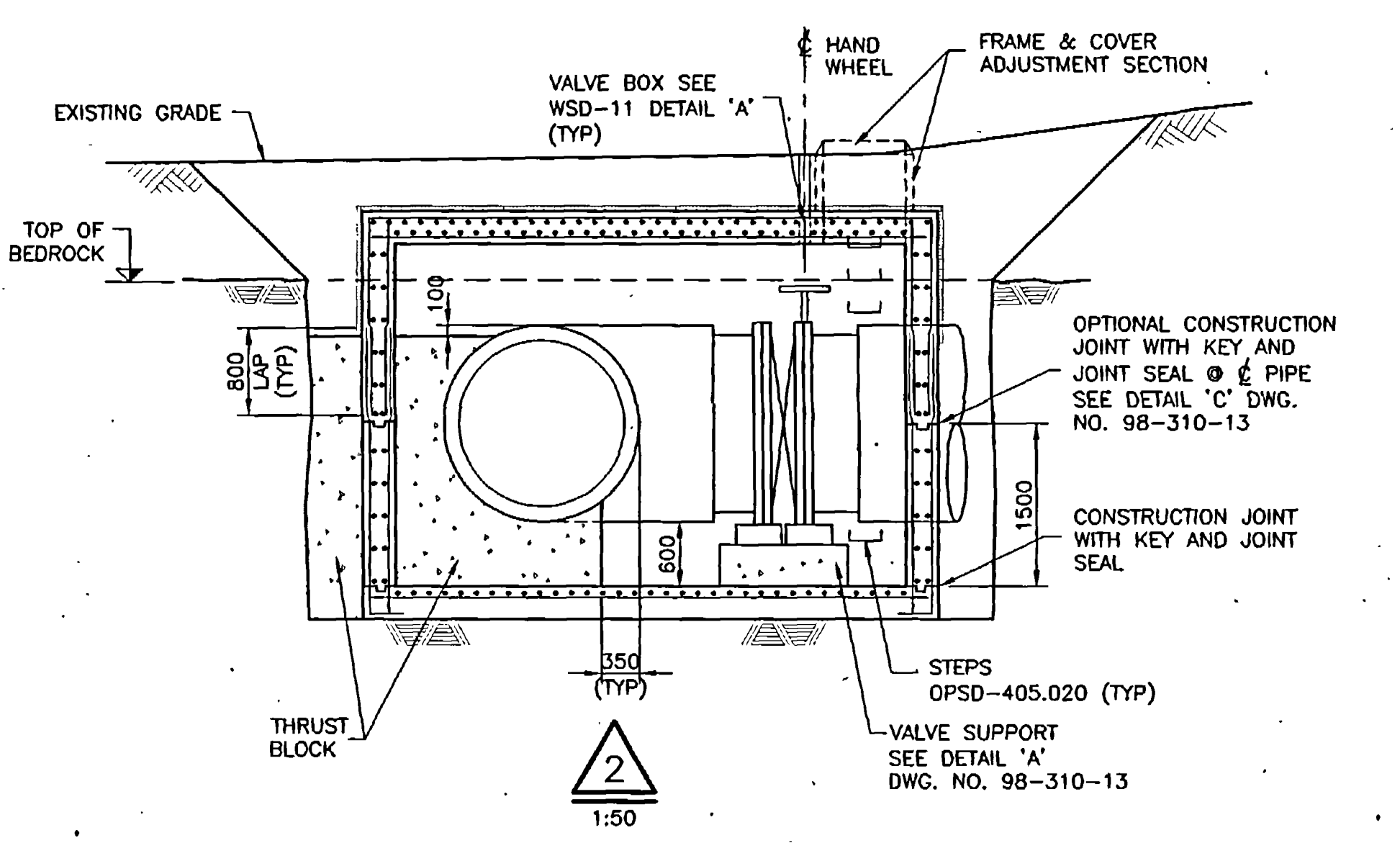
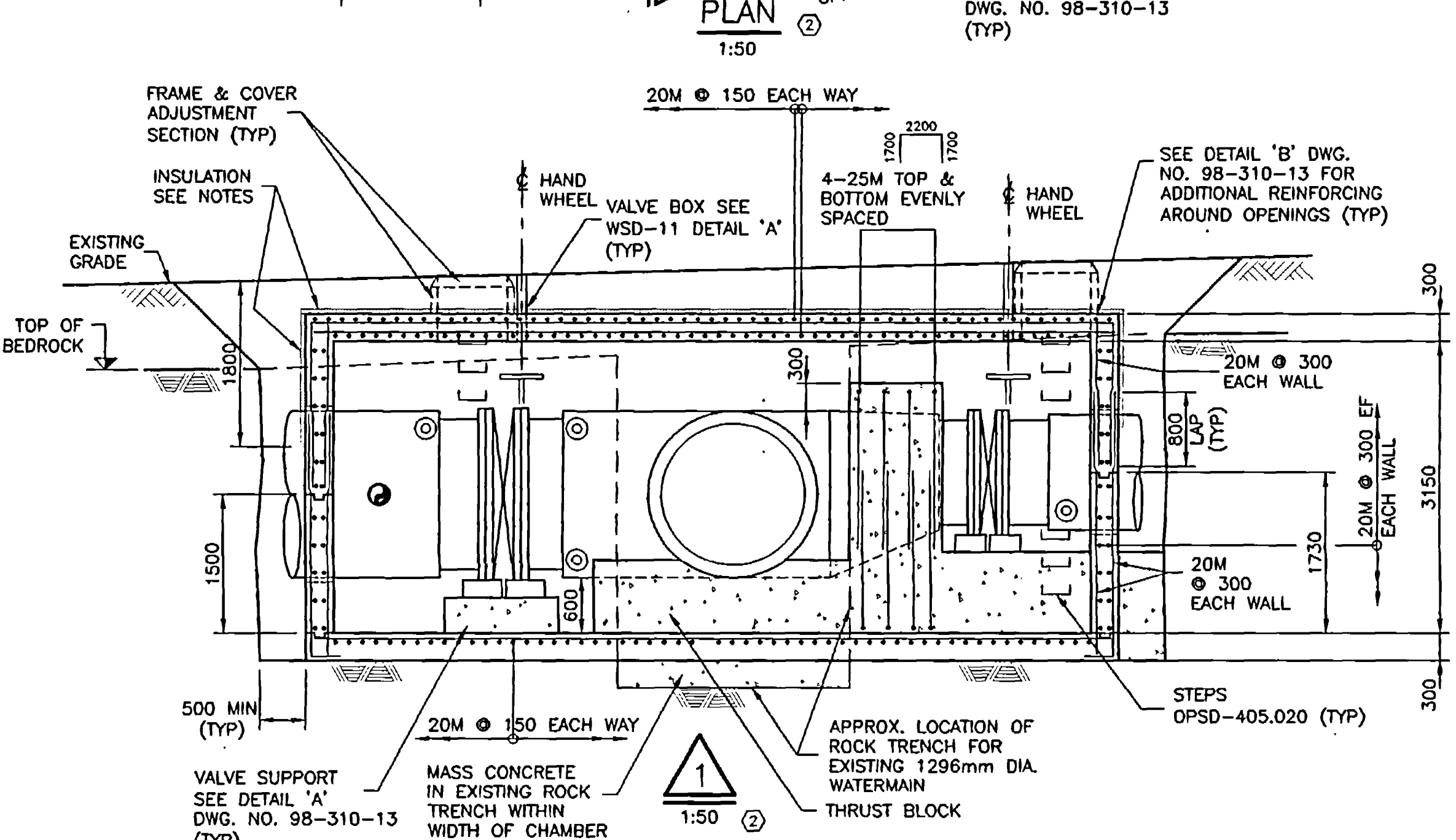
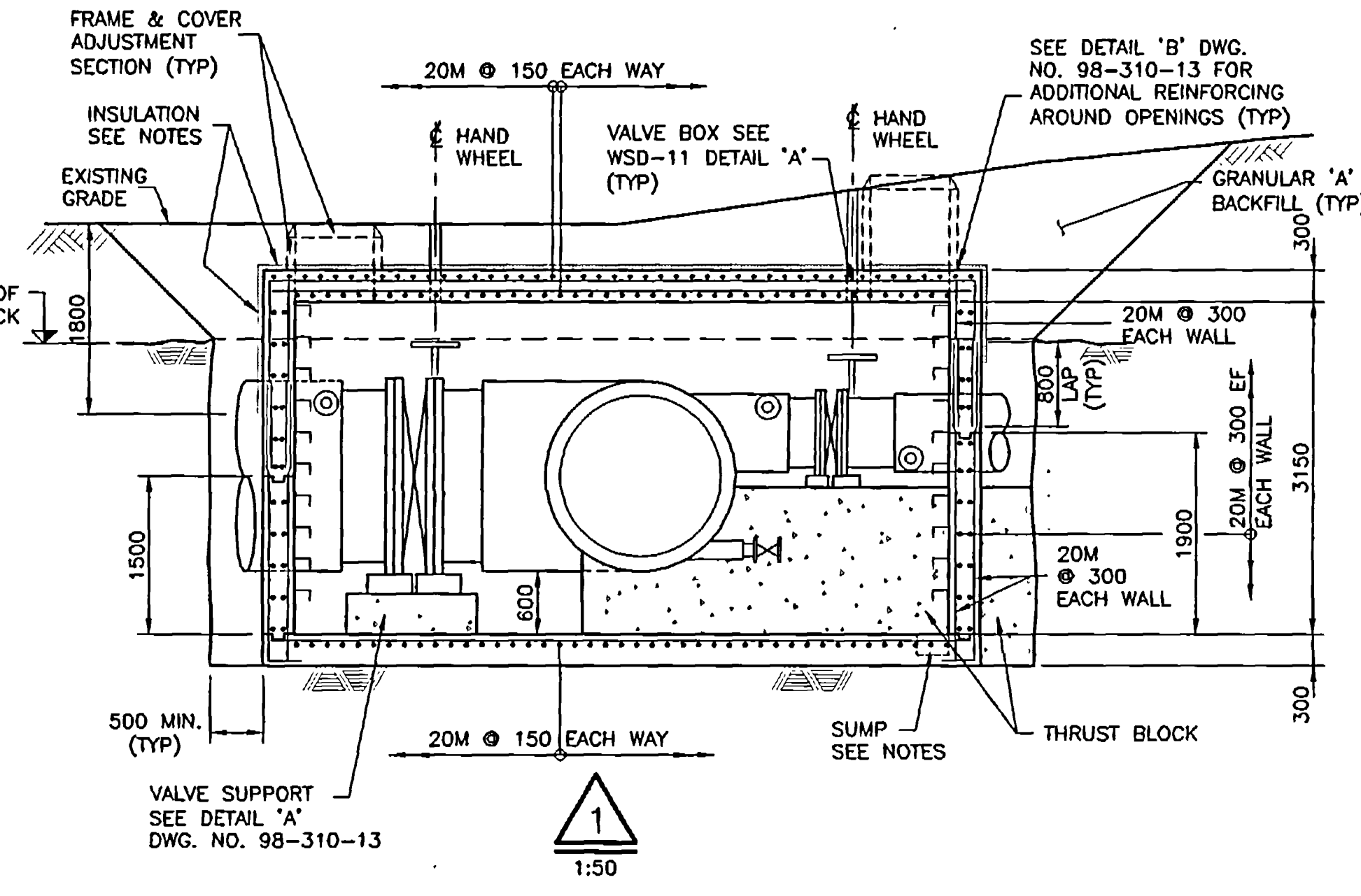

SPECIAL CHAMBER NO. 1

SPECIAL CHAMBER NO. 2

RECORD INFORMATION SUPPLIED BY RMOC

| | | |
|----------------------|----------|------|
| RECORD DRAWING | 11/01/00 | |
| 2 CONSTRUCTION ISSUE | 15/06/99 | |
| 1 ISSUED FOR TENDER | 20/04/99 | |
| No. | Revision | Date |

NOTES - SPECIAL CHAMBERS:

1. TOP OF CHAMBERS WITHIN 1800mm OF FINISHED GRADE SHALL BE INSULATED WITH 50mm STYROFOAM (HI-40) CEMENTED TO THE OUTSIDE OF THE WALLS AND ROOF
2. 300mm x 300mm x 200mm DEEP SUMP SHALL BE PROVIDED IN CHAMBERS AS SHOWN. CHAMBER FLOOR SHALL SLOPE TOWARDS SUMP.
3. ALL AIR RELIEF & DRAIN VALVES SHALL BE 100mm BUTTERFLY VALVES. OPERATING WHEELS MAY BE VERTICAL OR HORIZONTAL AS REQUIRED.
4. 100mm DIA. SLEEVES & VALVE BOXES SHALL BE INSTALLED ABOVE VALVE OPERATORS.
5. ALL JOINTS SHALL BE SEALED WITH A VOLCLAY-RX JOINT SEAL OR APPROVED EQUAL CENTERED IN WALL.
6. KEYS AT CONSTRUCTION JOINTS SHALL BE 100mm WIDE BY 50 mm DEEP, CENTRED IN THE WALL.

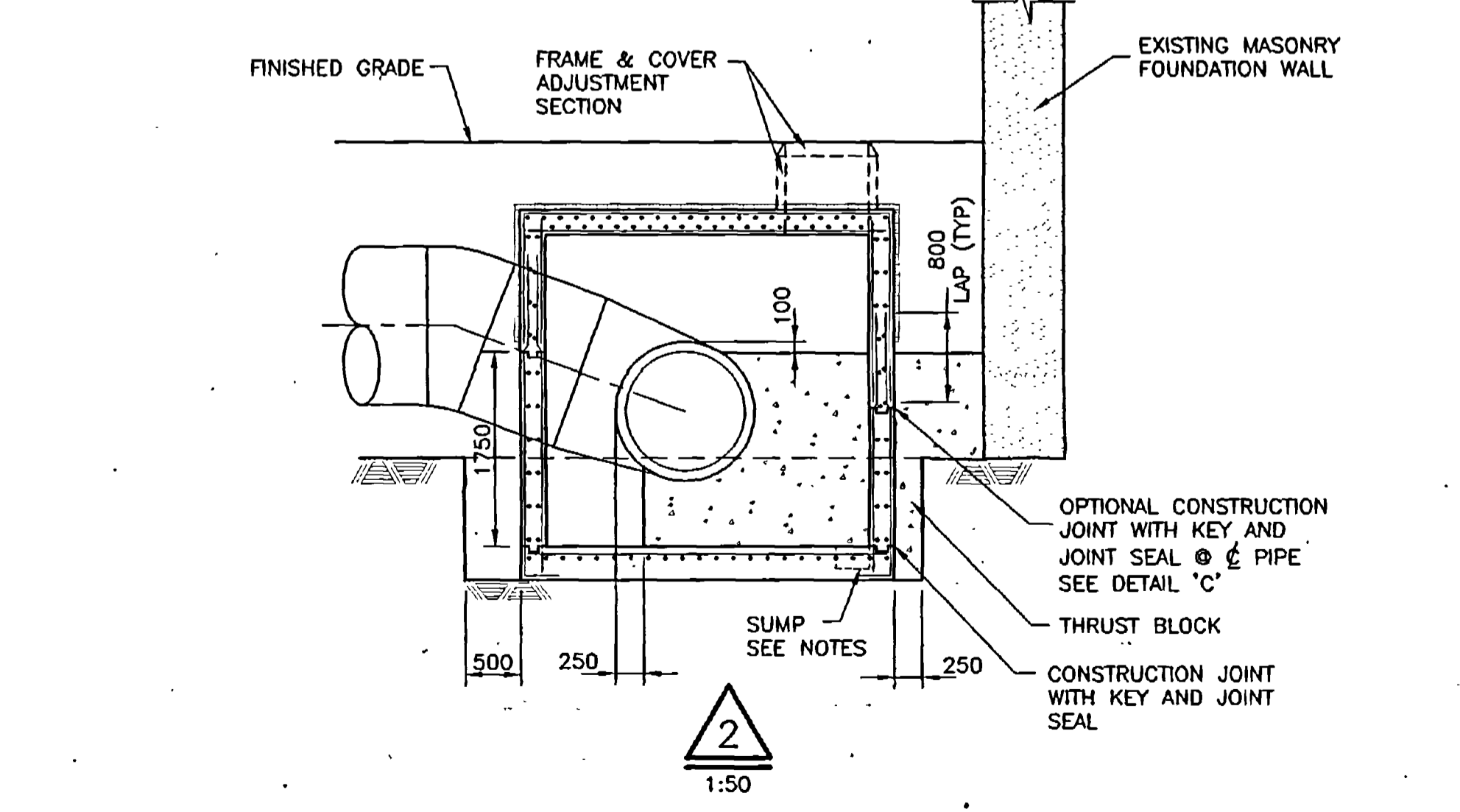
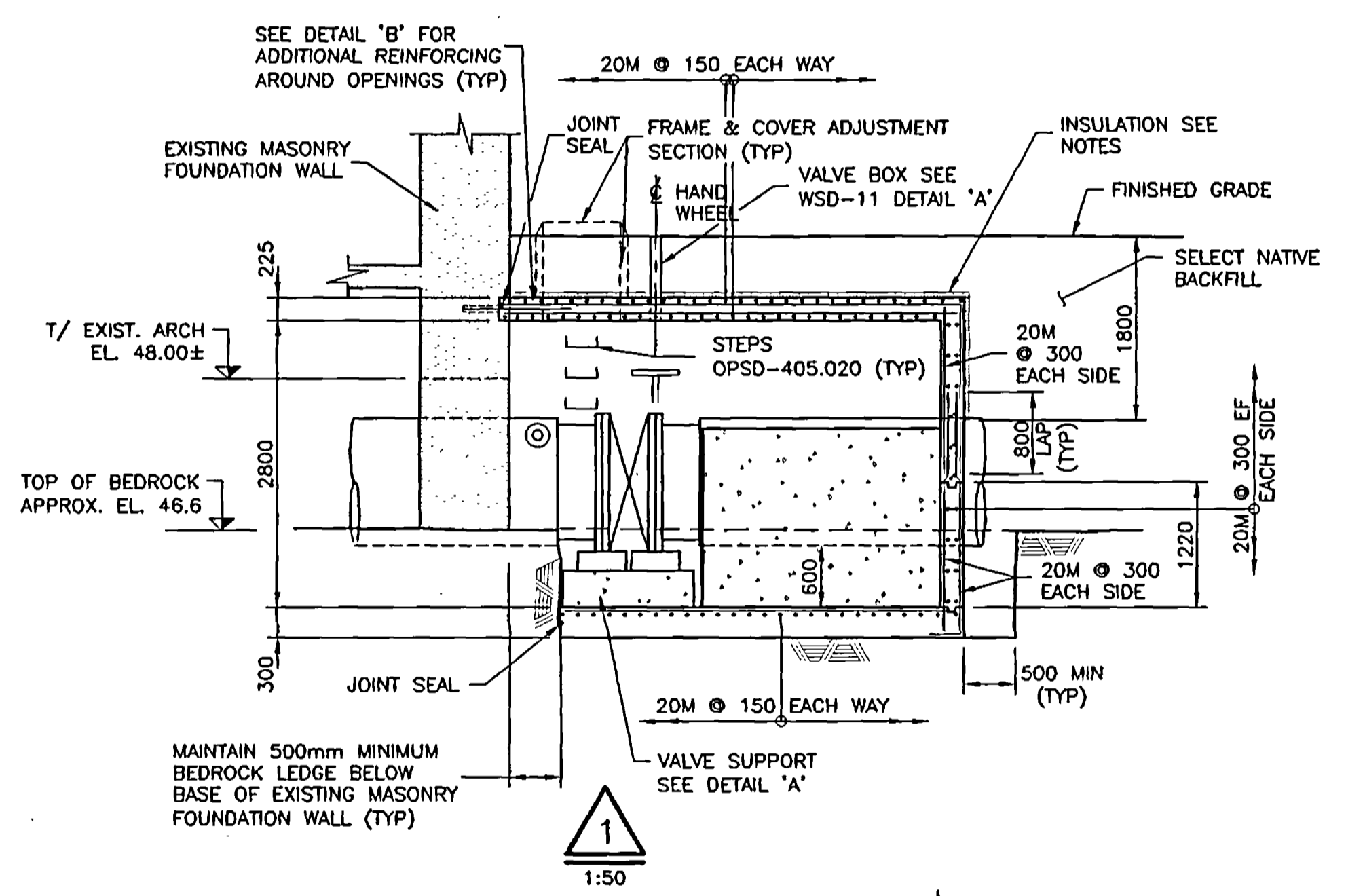
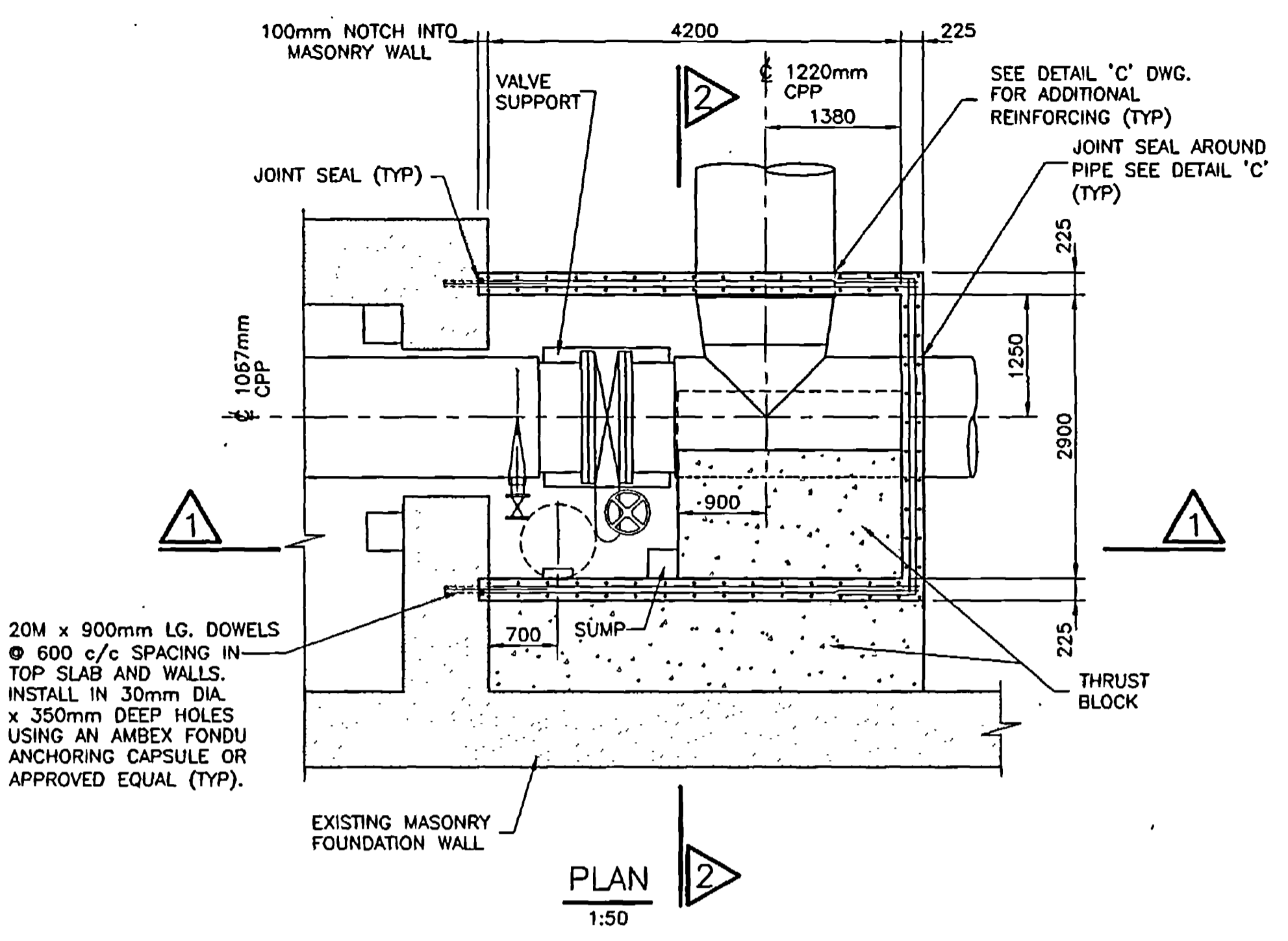

SPECIAL CHAMBER NO. 3

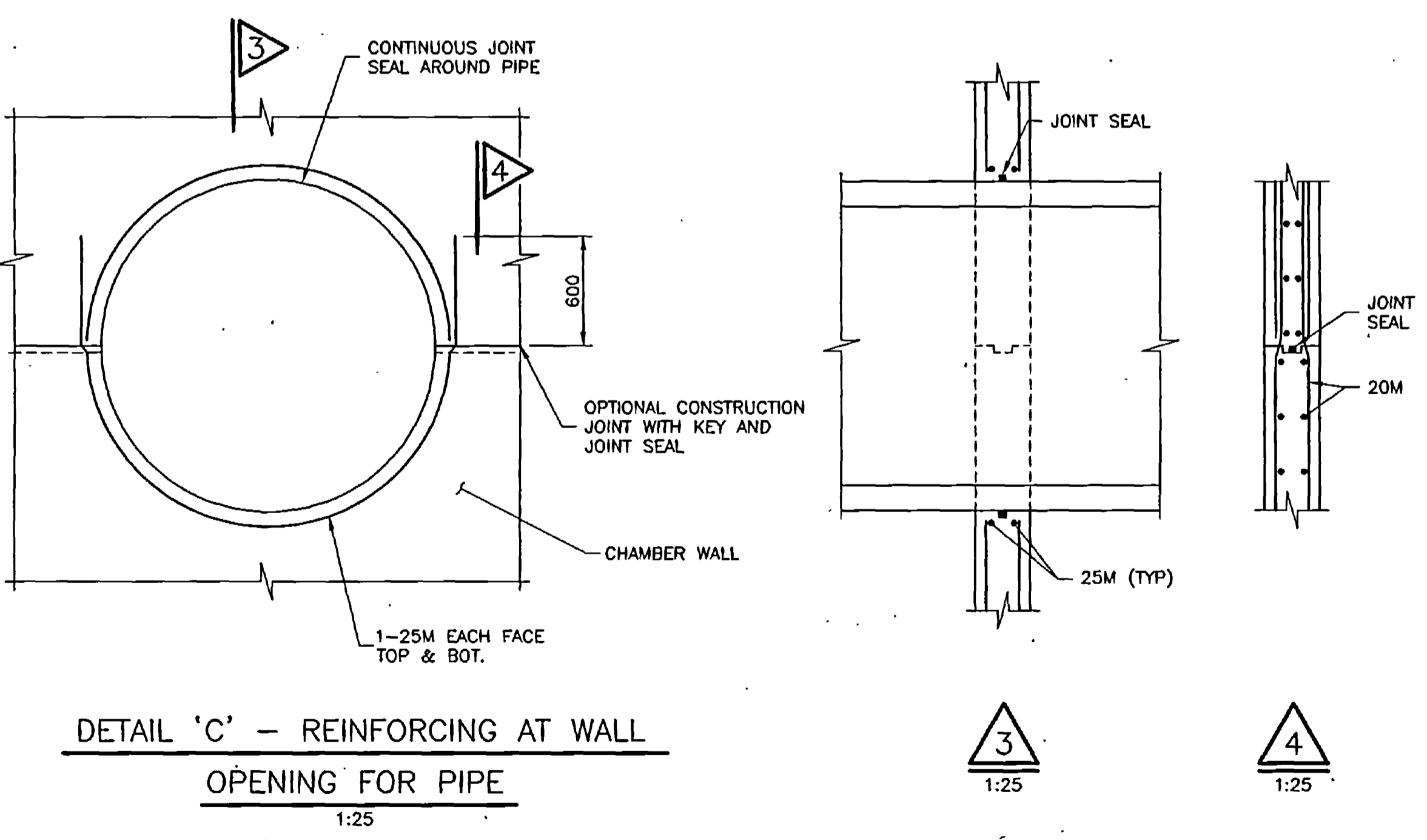
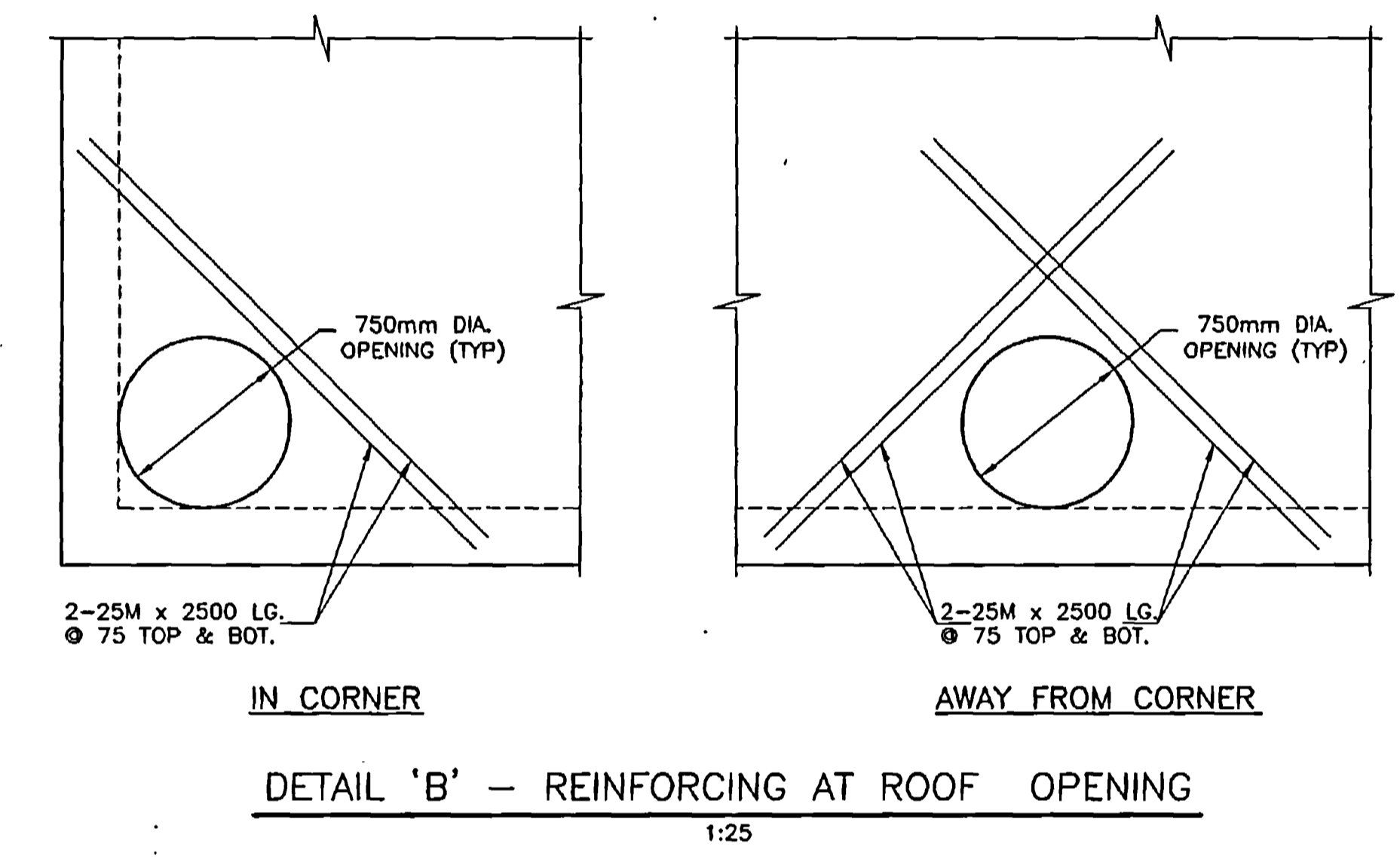
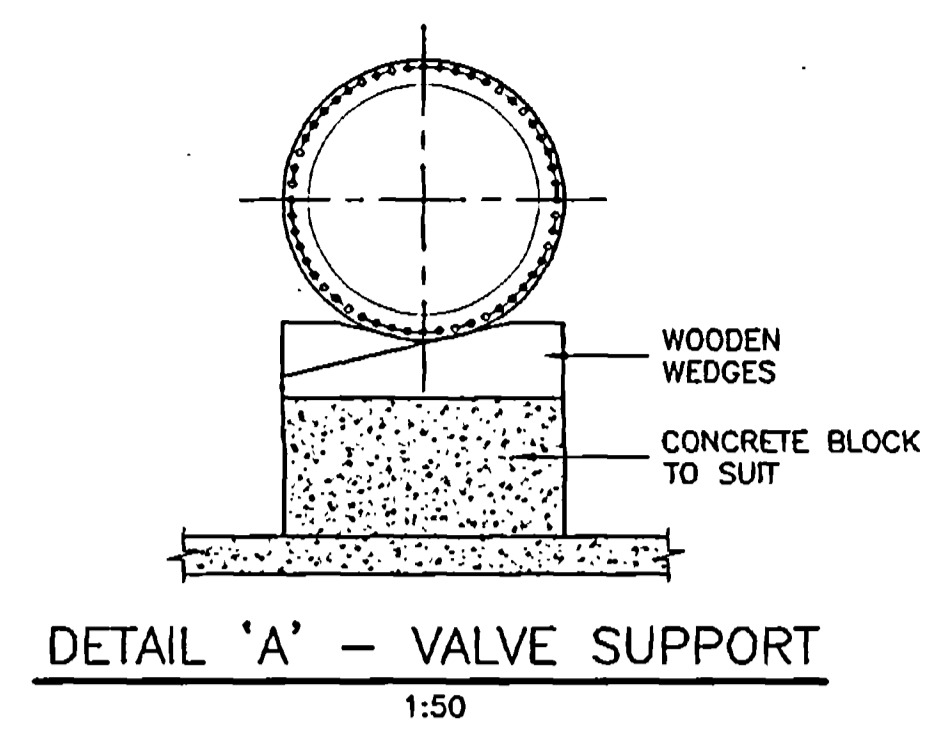

FILE NAME: E021811.E0K(CAD)\9831013.dwg

Appendix G

Regulatory Correspondence

Site: OPL / LAC Joint Facility

Capacity issues for sewers

Please use the attached guidelines in preparing the required servicing study for this site. For capacity issue, please see section 3.2.1 page 3-3 and follow this section to address the capacity issue on your “Servicing Study”. A completed checklist with corresponding references from the study is **mandatory** for the completeness of the serviceability study. Please add a completed checklist with the report.



ServicingGuidelines_final_Dec...



Confederation Line Proximity Guidelines.FTemplate Final Versi



Servicing Report

Required information for Water boundary conditions (not required if you're using existing service)

Boundary conditions are required to confirm that the required fire flows can be achieved as well as availability of the domestic water pressure on the city street in front of the development. Please use Table 3-3 of the MOE Design Guidelines for Drinking-Water System to determine Maximum Day and Maximum Hour peaking factors for 0 to 500 persons and use Table 4.2 of the Ottawa Design Guidelines, Water Distribution for 501 to 3,000 persons.

1. Location of Service
2. A sketch of the proposed water service to the city watermain
3. Street Number & Name
4. Type of development and units
5. Amount of fire flow required ___l/s (Calculation as per the FUS Method).
6. Average daily demand: -l/s
7. Maximum daily demand: -l/s
8. Maximum hourly daily demand: -l/s

Please note proposed development will require 2 separate service connections from the city watermains if the basic day demand is greater than 50m³/day to avoid the creation of a vulnerable service area. Two water meters will be required for two service connections and the service connections will have to be looped.

Utility conflict with the proposed servicing

- It is the consultant's sole responsibility to investigate the existing utilities in the proposed servicing area while preparing the Servicing and Grading Plans to avoid any conflict with the proposed services and will require a note stating this on the servicing plan.

Underground and above ground building footprints

All underground and above ground building footprints and permanent walls need to be shown on the plan to confirm that any of the permanent structures does not extend beyond the property line either above or below ground or does not encroach into sight triangles and future road widening protection limits.

SWM Criteria for the Catchment Area of the site being redeveloped: (Quantity control criteria)

Stormwater Management criteria for the City separated storm sewer system (please note if the separated storm sewer ultimately drains into combined sewer then please use combined sewer criteria as draining to the combined sewer would require MOE application)

- Allowable release rate will be 5-year pre-development rate.
- C Coefficient of runoff will need to be determined **as per existing conditions** but in no case more than 0.5
- TC =20 minutes or can be calculated,
- TC should not be less than 10 minutes, since the IDF curves become unrealistic less than 10min.
- Any storm events greater than 5 year, up to 100 year, and including 100-year storm events need to be stored on site.

Stormwater management criteria (Quality Control Issues)

It is consultant's responsibility to check with the Rideau Valley Conservation Authority (RVCA) for quality control issues. Please contact RVCA for further information.

Grade limitations for underground ramps

Underground ramps should be limited to a 12% grade and must contain a subsurface melting device when exceeding 6%. If the ramp's break over slope exceeds 8%, a vertical-curve transition or a transition slope of half the ramp slope should be used.

Sanitary

The allowable release rate should be based on the existing Zoning Designation using the City's Sewer Guidelines. If the proposal will have a greater flow than the allowable, then please do an analysis of the City's sanitary sewer system as per servicing guidelines to determine available capacity in the City's sanitary sewer system.

Monitoring MHs

Onsite Monitoring MHs are required for sewers (sanitary and storm) if there will be commercial component with the residential development.

Sight Triangle and Road widening requirement (By Transportation Project Manager Mr. Wally Dubyk)

Sight triangles and road widening are required for this site. Please check with Wally

Studies required for SPCA application

- Servicing Study
- Stormwater Management Report
- Geotechnical Study (as per City guidelines maximum spacing between boreholes is 50 meters, it could be more or less as per soil conditions, one borehole should be put down at least at the bottom of excavation.)
- Noise and vibration Study
- Phase 1 Study, needs to be prepared as per current MOECP regulation not as per CSA standards
- Phase 2, Depend on the Phase I recommendation if required needs to be prepared as per current MOECC regulation not as per CSA standard
- RSC is needed for more sensitive land use
- LRT _proximity study
- Constructability Report (A few significant city infrastructures are bisecting the property or running adjacent to the property , CSST, Interceptor Outfall Sewer, Backbone watermain)

The following studies and setback are required to work around the 1220 mm Backbone watermain :

1. At least 6 to 9m easement depending upon the depth of the water main is required for this infrastructure. It could go beyond the 9m due to soil conditions or other requirements from the watermain branch.
2. An Engineering Report is required describing the watermain's ability to support the additional fill or some other mitigation measures to allow the grade raise over the 1220 mm backbone watermain.
3. A Vibration Monitoring Program: A Vibration Monitoring Specialist Engineer shall undertake vibration monitoring, develop the vibration monitoring plan, ensure conformance and shall issue certificates of conformance. The Vibration Monitoring Specialist Engineer shall be a Licensed Engineer in the Province of Ontario with a minimum of five years experience in the field of Vibration Monitoring. Vibration monitors are to be placed directly on the watermain. The Maximum Peak Particle Velocities are to be in accordance with Table 1 of the City of Ottawa Specification F-1201.
4. A settlement Monitoring Program: A Settlement monitoring of the 1220 mm backbone watermain is required. The preparation of a settlement monitoring plan by a Geotechnical Engineer Licensed Engineer in the Province of Ontario shall be prepared.

MOECP SWM Requirement:

- To extend city storm and sanitary sewers on Albert Street

MOECP Other Requirements:

- If the propose land use generate stationary noise from heating, ventilating and air conditioning (HVAC) equipment, rotating machinery, generator, etc.

Related notes

RSC requirements:

This site was used as commercial, industrial and residential before. There were automotive garage, welding shop, and brass works shop on this property. The proposed use is more sensitive use than the previous uses, so an RSC is needed for this site.

In 2004, the Ontario Ministry of the Environment enacted Ontario Regulation 153/04 under the Environmental Protection Act to require a Record of Site Condition, when land use changes from a less sensitive use to a more sensitive use.

Noise and vibration Study

A Noise and Vibration study is required to capture noises from the surrounding streets as well any vibration impact on the development due to close proximity of the LRT. The acoustic consultant engineer must investigate any vibration impact on the proposed development due to the adjacent LRT and come up with the probable mitigation measures. That is Noise and Vibration Study is required for this development.

Requirements for build over CSST

This will be dealt under constructability Report.

Relevant information

1. The following documents are available for purchase from the City of Ottawa (Contact Charmaine Drouin at (613) 580-2424 x.13521 Charmaine.Drouin@ottawa.ca)
 - ⇒ Sewer Design Guidelines
 - ⇒ Water Distribution Design Guidelines
 - ⇒ Standard Tender Documents (Includes the City Standard Drawings & Specifications)
2. Record drawings and utility plans are also available for purchase from the City (Contact the City's Information Centre by email at InformationCentre@ottawa.ca or by phone at (613) 580-2424 x.44455).

Regards,

Abdul

Abdul Mottalib, M. Eng., P. Eng.
Sr. Infrastructure Approvals Engineer
Development Review Branch (Urban Services)
City of Ottawa
110 Laurier Avenue West, 4th Floor, Ottawa, ON, K1P 1J1
Tel. 613-580-2424 ext. 27798
Fax. 613-560-6006
E-mail: Abdul.Mottalib@ottawa.ca

Daniel Glauser

From: Bryan Kipp
Sent: Friday, May 29, 2020 11:50 AM
To: Daniel Glauser; Noah Chauvin; James Fookes
Subject: FW: New Ottawa Central Library - ECA Requirements

FYI

From: Diamond, Emily (MECP) [mailto:Emily.Diamond@ontario.ca]
Sent: Friday, May 29, 2020 11:49 AM
To: Bryan Kipp <BKipp@morrisonhershfield.com>
Subject: RE: New Ottawa Central Library - ECA Requirements

Hi Bryan,

From the information provided, the proposed project for the new library would fall under the exemption set out under Section 3 of Ontario Regulation 525/98. Therefore an ECA would not be required.

Thank you and have a great weekend.

Emily Diamond

Environmental Officer
Ministry of the Environment, Conservation and Parks
Ottawa District Office
2430 Don Reid Drive
Ottawa, Ontario, K1H 1E1
Tel: 613-521-3450 ext 238
Fax: 613-521-5437
e-mail: emily.diamond@ontario.ca

From: Bryan Kipp <BKipp@morrisonhershfield.com>
Sent: May 25, 2020 5:44 PM
To: Diamond, Emily (MECP) <Emily.Diamond@ontario.ca>
Subject: RE: New Ottawa Central Library - ECA Requirements

CAUTION -- EXTERNAL E-MAIL - Do not click links or open attachments unless you recognize the sender.

Hi Emily,

I hope this email finds you well.

I'm following up on my previous email. Could you please confirm if an ECA is required for this project.

Since I reached out in January we received the following input from the RVCA regarding stormwater quality treatment:

“The RVCA has no quality control requirements for the proposed development. Roof top stormwater runoff is considered clean for the purposes of our review, and the remainder of the site is to be landscaped. Best management practices are encouraged where possible to provide for water quality protection on site.”

Please let me know if you need any further information.

Regards,
Bryan

Bryan Kipp, P.Eng.
Municipal Engineer
BKipp@morrisonhershfield.com

 **MORRISON HERSHFIELD**
People • Culture • Capabilities
200 – 2932 Baseline Road | Ottawa, ON K2H 1B1 Canada
Dir: 613 690 3722 | Office: 613 739 2910 | Fax: 613 739 4926
morrisonhershfield.com

From: Bryan Kipp
Sent: Thursday, January 30, 2020 5:24 PM
To: Emily.Diamond@ontario.ca
Subject: New Ottawa Central Library - ECA Requirements

Hi Emily,

We are designing the Civil servicing for the new Ottawa Central Library ([located here on Google maps](#)) which will include new storm, sanitary, and water connections to City infrastructure. Attached is the latest site servicing drawing along with a sketch from GeoOttawa which identifies the site and downstream storm infrastructure.

Could you please confirm as to whether or not an ECA is required.

The Library will be provided with an underground stormwater retention system to reduce the release rate in accordance with City of Ottawa quantity control requirements. We are in the process of confirming with the RVCA if stormwater quality treatment is required. The Library site is non-industrial and does not receive flows from industrial land.

Please give me a call if you'd like to discuss.

Regards,
Bryan

Bryan Kipp, P.Eng.
Municipal Engineer
BKipp@morrisonhershfield.com

 **MORRISON HERSHFIELD**
People • Culture • Capabilities
200 – 2932 Baseline Road | Ottawa, ON K2H 1B1 Canada
Dir: 613 690 3722 | Office: 613 739 2910 | Fax: 613 739 4926
morrisonhershfield.com

Daniel Glauser

From: Bryan Kipp
Sent: Monday, May 25, 2020 4:39 PM
To: Daniel Glauser; Noah Chauvin
Subject: FW: New Ottawa Central Library - SWM Requirements

FYI

From: Eric Lalande [mailto:eric.lalande@rvca.ca]
Sent: Friday, January 31, 2020 11:03 AM
To: Bryan Kipp <BKipp@morrisonhershfield.com>; Glen McDonald <glen.mcdonald@rvca.ca>
Subject: RE: New Ottawa Central Library - SWM Requirements

Hi Bryan,

Glen has passed this along to me to review. The RVCA has no quality control requirements for the proposed development. Roof top stormwater runoff is considered clean for the purposes of our review, and the remainder of the site is to be landscaped. Best management practices are encouraged where possible to provide for water quality protection on site.

Thank you,

Eric Lalande, MCIP, RPP
Planner, Rideau Valley Conservation Authority
613-692-3571 x1137

From: Bryan Kipp <BKipp@morrisonhershfield.com>
Sent: Thursday, January 30, 2020 5:24 PM
To: Glen McDonald <glen.mcdonald@rvca.ca>
Cc: Eric Lalande <eric.lalande@rvca.ca>
Subject: New Ottawa Central Library - SWM Requirements

Hi Glen,

We are designing the Civil servicing for the new Ottawa Central Library ([located here on Google maps](#)) which will include a new storm connection to City infrastructure. Attached are the latest site servicing and grading drawings along with a sketch from GeoOttawa which identifies the site and downstream storm infrastructure.

Could you please confirm as to whether stormwater quality treatment is required for this site.

The Library will be provided with an underground stormwater retention system to reduce the release rate in accordance with City of Ottawa quantity control requirements. Runoff from softscaping and hardscaping will be collected by a local storm system. Flow from the building's roof and the local storm system will be directed to the underground system. The underground system will outlet to a new Albert St storm sewer that will be installed as part of the City's Albert Slater Reconstruction project. The new storm sewer will connect to an existing sewer which outlets to the Ottawa River downstream of the Fleet Street pumping station. No at-grade parking is proposed.

Please give me a call if you'd like to discuss.

Regards,

Bryan

Bryan Kipp, P.Eng.

Municipal Engineer

BKipp@morrisonhershfield.com



MORRISON HERSHFIELD
People • Culture • Capabilities

200 – 2932 Baseline Road | Ottawa, ON K2H 1B1 Canada
Dir: 613 690 3722 | Office: 613 739 2910 | Fax: 613 739 4926
morrisonhershfield.com

Appendix H

Non-Regulatory Correspondence

From: Bryan Kipp
Sent: Wednesday, May 27, 2020 11:51 AM
To: Daniel Glauser; Noah Chauvin
Subject: FW: 2020-05-07 OPLLAC - additional geotechnical info

FYI

From: Ghadbane, Sarah [mailto:Sarah_Ghadbane@golder.com]
Sent: Wednesday, May 27, 2020 11:20 AM
To: Fouchard, Richard <Richard.Fouchard@ottawa.ca>
Cc: Henderson, Brian (Ottawa) <Brian_Henderson@golder.com>; Bryan Kipp <BKipp@morrisonhershfield.com>
Subject: RE: 2020-05-07 OPLLAC - additional geotechnical info

NOTE: This email chain appears to contain email from outside Golder

Richard,

Please see below guidance regarding the long-term drainage:

The following provides an estimate of peak flows into the building perimeter and sub floor drains based on available information. The bulk of the groundwater inflow to the perimeter and under-slab drains will occur through the glacial till unit. Based on previous investigations conducted by Golder, the average ground surface elevation measured on-site was determined to be 62.3 meters above sea level (masl), and the geometric mean of groundwater elevation was measured to be 58.5 masl. It is understood that the proposed building will be about 110 m by 50 m in plan and will be founded at an elevation of about 58 masl (i.e. 4.3 m below the average ground surface). The hydraulic conductivity of the glacial till was determined to be as high as 6×10^{-7} m/s, based on the maximum hydraulic conductivity of in-situ measurements at three on-site locations.

The equation for groundwater flow into an unconfined circular excavation was used to estimate the groundwater inflow to the perimeter drains, based on a water table elevation of 59 masl (assuming a one half metre higher water table elevation than the average), a drain elevation of 57.7 masl and a glacial till hydraulic conductivity of 6×10^{-7} m/s. The rate of groundwater inflow into the perimeter drains is estimated to be approximately 87,000 L/day. A safety factor of 1.5 was applied to the inflow calculations. With a building perimeter of 320 metres, the estimated rate of groundwater inflow into the perimeter drains is approximately 3.2×10^{-3} Litres per second per metre (L/s.m). The inflow rate will decrease over time following a storm or periods of higher than average water table. It should be noted that this estimate assumes that all surface water is diverted away from the building foundations.

An analytical solution to calculate groundwater flow into the base of a circular excavation (Hvorslev, 1951) was used to estimate the groundwater inflow to the sub-floor drains underneath the proposed building based on a water table elevation of 59 masl (assuming a one half metre higher water table elevation than the average), a drain elevation of 57.7 masl and a glacial till hydraulic conductivity of 6×10^{-7} m/s. The rate of groundwater inflow into the sub-floor drains is estimated to be approximately 23,400 L/day. A safety factor of 1.5 was applied to the inflow calculations. With a building area of 5,500

square metres (m²), the estimated rate of groundwater inflow into the sub floor drains is approximately 4.9x10⁻⁵ Litres per second per square metre (L/s.m²). The inflow rate will decrease over time following a storm or periods of higher than average water table. It should be noted that this estimate also assumes that all surface water is diverted away from the building foundations.

Please let us know if you have any questions.

Thanks,

Sarah

Sarah Ghadbane (P.Eng.)

Geotechnical Engineer



Golder Associates Ltd.

1931 Robertson Road, Ottawa, Ontario, Canada, K2H 5B7

T: +1 613 592 9600 | **D:** +1 (613) 592-9600 x3227 | **C:** +1 (613) 880-4240 | golder.com

[LinkedIn](#) | [Instagram](#) | [Facebook](#) | [Twitter](#)

Work Safe, Home Safe

This email transmission is confidential and may contain proprietary information for the exclusive use of the intended recipient. Any use, distribution or copying of this transmission, other than by the intended recipient, is strictly prohibited. If you are not the intended recipient, please notify the sender and delete all copies. Electronic media is susceptible to unauthorized modification, deterioration, and incompatibility. Accordingly, the electronic media version of any work product may not be relied upon.

Golder and the G logo are trademarks of Golder Associates Corporation

Please consider the environment before printing this email.

From: Fouchard, Richard <Richard.Fouchard@ottawa.ca>
Sent: May 21, 2020 6:07 PM
To: Ghadbane, Sarah <Sarah_Ghadbane@golder.com>
Subject: FW: 2020-05-07 OPLLAC - additional geotechnical info

EXTERNAL EMAIL

Can you meet the deadline requested by MH (Bryan Kipp)?
(Early next week).

Richard Fouchard

From: Bryan Kipp <BKipp@morrisonhershfield.com>
Sent: May 21, 2020 5:56 PM
To: Ralph Wiesbrock <rwiesbrock@kwc-arch.ca>; Fouchard, Richard <Richard.Fouchard@ottawa.ca>
Cc: James Fookes <JFookes@morrisonhershfield.com>; Simon Green <Simon-a.Green@arup.com>
Subject: RE: 2020-05-07 OPLLAC - additional geotechnical info

CAUTION: This email originated from an External Sender. Please do not click links or open attachments unless you recognize the source.

ATTENTION : Ce courriel provient d'un expéditeur externe. Ne cliquez sur aucun lien et n'ouvrez pas de pièce jointe, excepté si vous connaissez l'expéditeur.

Hi Richard and Ralph,

Just wanted to follow-up on this request. The following item is mainly what we need clarification on at this time.

- Provide estimate for peak long-term subsoil drainage in L/s per meter of perimeter foundation wall, and L/s.m2 under P2

It would be helpful if we can get this information this week or early next week, such that we can incorporate in time for the first Site Plan Control submission.

The remaining items (highlighted in green below) have been discussed with Golder in the Early Works Coordination meetings. I understand Golder is in the process of preparing the vibration control plan.

Thanks,
Bryan

Bryan Kipp, P.Eng.
Municipal Engineer
BKipp@morrisonhershfield.com

 **MORRISON HERSHFIELD**
People • Culture • Capabilities
200 – 2932 Baseline Road | Ottawa, ON K2H 1B1 Canada
Dir: 613 690 3722 | Office: 613 739 2910 | Fax: 613 739 4926
morrisonhershfield.com

From: Ralph Wiesbrock [<mailto:rwiesbrock@kwc-arch.ca>]
Sent: Thursday, May 7, 2020 11:04 AM
To: Richard.Fouchard@ottawa.ca
Cc: Bryan Kipp <BKipp@morrisonhershfield.com>; James Fookes <JFookes@morrisonhershfield.com>
Subject: RE: 2020-05-07 OPLLAC - additional geotechnical info

Richard – I think I've found another piece of the civil request:

- Provide estimate for peak long-term subsoil drainage in L/s per meter of perimeter foundation wall, and L/s.m2 under P2 slab.

Sorry for the confusion. Let me know if it would be helpful to have a quick call to review with MH.

Ralph Wiesbrock, OAA, FRAIC, LEED AP
Partner / Principal

KWC Architects Inc.
383 Parkdale Avenue, suite 201, Ottawa, Ontario K1Y 4R4

From: Ralph Wiesbrock
Sent: May 7, 2020 10:10 AM
To: Richard.Fouchard@ottawa.ca
Cc: Bryan Kipp <BKipp@morrisonhershfield.com>; James Fookes <JFookes@morrisonhershfield.com>
Subject: 2020-05-07 OPLLAC - additional geotechnical info

Hi Richard,

Civil has requested some additional detailed geotechnical information that seems to have got lost in the shuffle at my end. I'm pulling forward the relevant part of the thread here:

1. *Project specific requirements:*
 - a. *Temporary support of backbone watermain on Albert Street during installation of sewer below watermain. Please provide details regarding this proposed sewer installation and excavations. Also, will this be the responsibility of the designer, or the contractor as a part of temporary works?*

[MH] See attached drawing C001. The proposed sanitary sewer crosses below the 1220mm High Pressure Trunk water Main (HPTM) near the Brickhill/Albert St intersection. I have also attached the as-built drawing of the watermain in this location. At this stage we are assuming that the sewer will be installed by open cut excavation. Temporary support will be the responsibility of the contractor, but we would appreciate your input to verify that the proposed design is constructible.

- b. *Vibration monitoring and alert levels for backbone watermains on Albert and Commissioner Streets (provide specification). Also for Interceptor Outfall Sewer and Combined Sewage Storage Tunnel if requested by City. Input can be provided for vibration monitoring for backbone watermains; however, production of a vibration monitoring specification has not been included in our scope of work. Input to vibration monitoring for the CSST should be confirmed with the CSST design team.*

[MH] I have attached minutes from a meeting held with Asset Management Branch last year – there are a few items that you should be aware of, where the City made commitments to engage a geotechnical engineer to provide recommendations regarding the risks associated with excavation adjacent to the HPTMs. It sounds like there is a need to add these tasks to your scope.

I have also attached a drawing of the Interceptor Outfall Sewer (IOS). I wanted to make sure that you are aware of this sewer. It is located at a similar depth to the CSST and runs along the northern edge of the site. It will be below the foundation in some locations. It is also discussed in the attached meeting minutes.

Hopefully we can get a response quickly. I would be happy to set up a conference call/webex meeting to review if needed.

Ralph Wiesbrock, OAA, FRAIC, LEED AP

Partner / Principal

KWC Architects Inc.

383 Parkdale Avenue, suite 201, Ottawa, Ontario K1Y 4R4

T: 613-238-2117 ext. 225 C: 613-728-5800 E: rwiesbrock@kwc-arch.com

'

This e-mail originates from the City of Ottawa e-mail system. Any distribution, use or copying of this e-mail or the information it contains by other than the intended recipient(s) is unauthorized. Thank you.

Le présent courriel a été expédié par le système de courriels de la Ville d'Ottawa. Toute distribution, utilisation ou reproduction du courriel ou des renseignements qui s'y trouvent par une personne autre que son destinataire prévu est interdite. Je vous remercie de votre collaboration.

'

From: Bryan Kipp
Sent: Wednesday, May 27, 2020 3:46 PM
To: Daniel Glauser; Noah Chauvin
Subject: FW: [External] RE: OPL-LAC - Civil Mechanical Coordination

FYI

From: Bryan Kipp
Sent: Wednesday, May 27, 2020 3:36 PM
To: Simon Green <Simon-a.Green@arup.com>
Cc: Geoffrey Iwasa <Geoffrey.Iwasa@arup.com>; Eric Emery <EEmery@morrisonhershfield.com>; Najiba Hussain <Najiba.Hussain@arup.com>; James Fookes <JFookes@morrisonhershfield.com>
Subject: RE: [External] RE: OPL-LAC - Civil Mechanical Coordination

Hi Simon,

Regarding servicing of the loading dock area, we will go with option 2 for the first Site Plan Control submission based on the following:

- We've just received record info on the Commissioner storm sewer, and have not done a complete analysis to confirm if it would have available capacity. A high-level check indicates the sewer has 2-year capacity, however we believe the Stage 1 LRT tunnel has a gravity or pumped discharge to it as well, which would further reduce capacity. So in order to make this option work, we would need to introduce a second stormwater storage tank under the loading dock in order to control flow down to the 2-year pre-development peak flow. From the viewpoint of overall OPL drainage system complexity, O&M of an added SWM tank, and potential issues with demonstrating the sewer has available capacity, this option is not preferable to us at this time. We'll let you know if we believe the option to be viable once we've performed further analysis.

Also, noted regarding keeping the south storm sewer invert at 57.15m. We will keep the invert at this depth for now. Let us know if you meet with success in making it shallower.

Regards,
Bryan

Bryan Kipp, P.Eng.
Municipal Engineer
BKipp@morrisonhershfield.com

 **MORRISON HERSHFIELD**
People • Culture • Capabilities
200 – 2932 Baseline Road | Ottawa, ON K2H 1B1 Canada
Dir: 613 690 3722 | Office: 613 739 2910 | Fax: 613 739 4926
morrisonhershfield.com

From: James Fookes
Sent: Wednesday, May 27, 2020 2:42 PM
To: Simon Green <Simon-a.Green@arup.com>
Cc: Geoffrey Iwasa <Geoffrey.Iwasa@arup.com>; Eric Emery <EEmery@morrisonhershfield.com>; Najiba

Hussain <Najiba.Hussain@arup.com>; Bryan Kipp <BKipp@morrisonhershfield.com>
Subject: RE: [External] RE: OPL-LAC - Civil Mechanical Coordination

No problem, thanks Simon.

Regards,
James

From: Simon Green <Simon-a.Green@arup.com>
Sent: May 27, 2020 12:29 PM
To: James Fookes <JFookes@morrisonhershfield.com>
Cc: Geoffrey Iwasa <Geoffrey.Iwasa@arup.com>; Eric Emery <EEmery@morrisonhershfield.com>; Najiba Hussain <Najiba.Hussain@arup.com>; Bryan Kipp <BKipp@morrisonhershfield.com>
Subject: RE: [External] RE: OPL-LAC - Civil Mechanical Coordination

Hi again,

Confirming 63.1L/s [1,000gpm] for the fire pump. Sorry again to have given you incorrect information before. Hopefully we caught this before you submitted your application...

Kind regards,

Simon Green
Senior Mechanical Designer

Arup
121 Bloor Street East Suite 900 Toronto ON M4W 3M5 Canada
t: +1 416 515 0915 d: +1 647 288 2365
m: +1 647 331 7075
www.arup.com

From: Simon Green
Sent: Wednesday, May 27, 2020 9:06 AM
To: 'James Fookes' <JFookes@morrisonhershfield.com>
Cc: Geoffrey Iwasa <Geoffrey.Iwasa@arup.com>; Eric Emery <EEmery@morrisonhershfield.com>; Najiba Hussain <Najiba.Hussain@arup.com>; Bryan Kipp <BKipp@morrisonhershfield.com>
Subject: RE: [External] RE: OPL-LAC - Civil Mechanical Coordination [Filed 27 May 2020 09:06]

Hi James,

No need to apologize. We obviously won't be able to make updates in time for the 30% CD package, but I think our order of preference would be 1, 2 then 3. Some thoughts:

1. This options avoids foundation sumps/pumping and running the loading dock area drain through the building, both of which will save cost and simplify design. We'll wait for

Golder's final assessment, but our very crude and relatively conservative estimate for the peak foundation drainage would be ~25L/s. I.e. small compared to other surface and roof flows.

2. However, if the Commissioner Street system is at capacity or too high to reach on gravity, we can definitely pump. We would suggest doing so inside the building – it requires less excavation, is better for maintenance during winter and is more central to the foundations/P2 slab. There is also no significant overflow risk to worry about like for the main detention tank.

Regardless, we are still hoping for a leaving storm pipe invert of approx. 57.15m. As discussed, virtually all roof drainage needs to pass through the detention tank to meet City of Ottawa requirements. This means that we need to offset a roof drain from the very north end of the building to the very south the while avoiding a slew of sensitive archive/gallery spaces, fire stairs, voids, etc. Because of the compressed head height and traffic routes on parking levels, we are being forced to do most of this horizontal offset buried under the P2 slab on grade.

We'll review over the next few weeks and see if we can raise that invert by a few hundred mm, but we unfortunately don't think we can target something like 60.50m.

Lastly, time for us to apologize. On technical review, we may have missed a detail in our fire pump sizing. We will confirm ASAP, hopefully today, but it may go up one size to 63.1L/s [1,000gpm].

Kind regards,

Simon Green
Senior Mechanical Designer

Arup
121 Bloor Street East Suite 900 Toronto ON M4W 3M5 Canada
t: +1 416 515 0915 d: +1 647 288 2365
m: +1 647 331 7075
www.arup.com

From: James Fookes <JFookes@morrisonhershfield.com>
Sent: Tuesday, May 26, 2020 11:55 AM
To: Simon Green <Simon-a.Green@arup.com>
Cc: Geoffrey Iwasa <Geoffrey.Iwasa@arup.com>; Eric Emery <EEmery@morrisonhershfield.com>; Najiba Hussain <Najiba.Hussain@arup.com>; Bryan Kipp <BKipp@morrisonhershfield.com>
Subject: RE: [External] RE: OPL-LAC - Civil Mechanical Coordination

Hi Simon,

Apologies for not catching this earlier, but we have run into a problem with using the proposed storm pumps to service the foundation drains. The City requires foundation drains to be connected downstream of any stormwater flow control measure. Typically this would be an orifice plate or vortex device in a manhole downstream of a stormwater storage tank, but in this case the pump station is providing flow control. The pumps are being specified with a deliberately limited capacity to match the allowable stormwater release rate to the sewer, and the proposed storm tank provides attenuation storage.

The foundation drains will therefore need to outlet separately. We are looking at a few options for this:

1. Make use of existing storm sewer on Commissioner St. This sewer is low enough that it could provide a gravity outlet to both the foundation drains and loading dock area. Whether we can use it depends on capacity. We are working on an analysis of available capacity and should have an answer by the end of the day.
2. Sump pump within the building. The easiest place for this to discharge would be to a manhole that we will provide at the south corner of the building, but a discharge to the storm sewer anywhere along Albert St would be feasible.
3. Separate pump station outside the building. This could be located next to the main storm pump station, or could be elsewhere (e.g. in the loading dock).

With the foundation drains handled separated, and assuming that we reroute the loading dock drainage elsewhere, the storm tank and main pump station can be shallower. Please let us know if the main roof drain leader could exit the building at around 60.50m elevation? If not, please confirm the shallowest elevation at which this could exit. The foundation drain pump would handle any roof or area drains that are too low to discharge to the main roof drain leader.

I will let you know as soon as we have an answer about Option 1 above. If this doesn't work we will need to determine what works best in terms of servicing both the foundation drains and loading dock.

Regards,
James

From: Bryan Kipp <BKipp@morrisonhershfield.com>

Sent: May 21, 2020 5:58 PM

To: Simon Green <Simon-a.Green@arup.com>

Cc: Geoffrey Iwasa <Geoffrey.Iwasa@arup.com>; James Fookes <JFookes@morrisonhershfield.com>;

Eric Emery <EEmery@morrisonhershfield.com>; Najiba Hussain <Najiba.Hussain@arup.com>

Subject: RE: [External] RE: OPL-LAC - Civil Mechanical Coordination

Hi Simon,

Thanks for these details on your design. I will follow-up if we need any clarification.

Please see attached coordination markups from yesterday's meeting. I will follow-up with Enbridge first thing tomorrow.

Regards,
Bryan

From: Bryan Kipp
Sent: Wednesday, May 27, 2020 11:48 AM
To: Daniel Glauser; Noah Chauvin
Subject: FW: OPL- LAC: Green Roof
Attachments: A110.pdf; 19004 L1.01 MATERIALS PLAN L1.pdf

FYI

From: Bryan Kipp
Sent: Wednesday, May 27, 2020 11:47 AM
To: 'Matthew Tsui' <mtsui@dsai.ca>
Cc: Sydney Browne <sbrowne@dsai.ca>; Gary McCluskie <gmccluskie@dsai.ca>; Jeff Geldart <JGeldart@dsai.ca>; Joseph Yau <JYau@dsai.ca>; Ralph Wiesbrock <rwiesbrock@kwc-arch.ca>; Steve Culver <SCulver@dsai.ca>; PFS Maureen Hetzler (mhetzler@pfs.bc.ca) <mhetzler@pfs.bc.ca>; James Fookes <JFookes@morrisonhershfield.com>; Noah Chauvin <NChauvin@morrisonhershfield.com>; Shahrad Khorasanizadeh <SKhorasanizadeh@dsai.ca>
Subject: RE: OPL- LAC: Green Roof

Hi Matthew,

Thanks for this information.

We do not need 2500sm of green roof for our stormwater management design. Essentially, the smaller the area of green roof, the higher the amount of runoff which will be generated, which will result in a larger stormwater storage tank volume. Based on our latest stormwater management calculations, the required storage volume will be equal to or less than the volume estimated at time of design development costing, so we are in good shape.

To confirm, for the first Site Plan Control submission we will account for 2200sm of green roof per your attached markup. We will also consider the plantings at the Level 1 terrace level when calculating the overall post-development site imperviousness, and associated runoff volume.

Regards,
Bryan

Bryan Kipp, P.Eng.
Municipal Engineer
BKipp@morrisonhershfield.com

 **MORRISON HERSHFIELD**
People • Culture • Capabilities
200 – 2932 Baseline Road | Ottawa, ON K2H 1B1 Canada
Dir: 613 690 3722 | Office: 613 739 2910 | Fax: 613 739 4926
morrisonhershfield.com

From: Matthew Tsui [<mailto:mtsui@dsai.ca>]
Sent: Thursday, May 21, 2020 6:23 PM
To: Bryan Kipp <BKipp@morrisonhershfield.com>
Cc: Sydney Browne <sbrowne@dsai.ca>; Gary McCluskie <gmccluskie@dsai.ca>; Jeff Geldart

<JGeldart@dsai.ca>; Joseph Yau <JYau@dsai.ca>; Ralph Wiesbrock <rwiesbrock@kwc-arch.ca>; Steve Culver <SCulver@dsai.ca>; PFS Maureen Hetzler (mhetzler@pfs.bc.ca) <mhetzler@pfs.bc.ca>; James Fookes <JFookes@morrisonhershfield.com>; Noah Chauvin <NChauvin@morrisonhershfield.com>; Shahrads Khorasanizadeh <SKhorasanizadeh@dsai.ca>

Subject: RE: OPL- LAC: Green Roof

Thanks Bryan. Please see attached sketches and notes:

ROOF PLAN

Our current roof plan shows 2200sm of green roof (please see attached.) We can bump this up to 2500 sm if this is required. I am unclear as to where the 2500 sm number came from and if there is a requirement to hit this number.

LEVEL 1 TERRACE PLAN

The current landscape plan shows some green areas with "raised planters." For SPA purposes, is this area considered to be green roof? Because of the soil depth required for planting we understand the soil needs to be in a raised condition instead of being flush with paved surface.

Thanks

Matthew Tsui

M.Arch, OAA, MRAIC, LEED AP
Associate

**diamond
schmitt**

Diamond Schmitt Architects

384 Adelaide Street West, Suite 100
Toronto, Ontario, Canada M5V 1R7

t: 416 862 8800 x512

mtsui@dsai.ca

From: Bryan Kipp <BKipp@morrisonhershfield.com>

Sent: Thursday, May 21, 2020 4:40 PM

To: Matthew Tsui <mtsui@dsai.ca>

Cc: Sydney Browne <sbrowne@dsai.ca>; Gary McCluskie <gmcluskie@dsai.ca>; Jeff Geldart <JGeldart@dsai.ca>; Joseph Yau <JYau@dsai.ca>; Ralph Wiesbrock <rwiesbrock@kwc-arch.ca>; Steve Culver <SCulver@dsai.ca>; PFS Maureen Hetzler (mhetzler@pfs.bc.ca) <mhetzler@pfs.bc.ca>; James Fookes <JFookes@morrisonhershfield.com>; Noah Chauvin <NChauvin@morrisonhershfield.com>

Subject: OPL- LAC: Green Roof

Hi Matthew,

Hope you are keeping well.

Could you or a member of the DSAI team please confirm the current green roof area. We need this in order to finalize our stormwater management calculations for next week's Site Plan Control submission.

Prior to the DD submission in January you had advised the following:

- There is roughly 2500 sm of green roof on level 5 – please refer to drawing A109 (sent Jan. 6 via Newforma and reattached in this email.) Also, a large level 1 roof terrace has been added north of the OPL library express, which is a mix of hard and soft scape – please refer to PFS drawing

We have reviewed the building CAD drawings which Joseph transmitted yesterday, however it is not readily apparent if the green roof remains in scope.

Thanks,
Bryan

Bryan Kipp, P.Eng.

Municipal Engineer

BKipp@morrisonhershfield.com



200 – 2932 Baseline Road | Ottawa, ON K2H 1B1 Canada
Dir: 613 690 3722 | Office: 613 739 2910 | Fax: 613 739 4926
morrisonhershfield.com

Appendix I

Checklist

4. Development Servicing Study Checklist

The following section describes the checklist of the required content of servicing studies. It is expected that the proponent will address each one of the following items for the study to be deemed complete and ready for review by City of Ottawa Infrastructure Approvals staff.

The level of required detail in the Servicing Study will increase depending on the type of application. For example, for Official Plan amendments and re-zoning applications, the main issues will be to determine the capacity requirements for the proposed change in land use and confirm this against the existing capacity constraint, and to define the solutions, phasing of works and the financing of works to address the capacity constraint. For subdivisions and site plans, the above will be required with additional detailed information supporting the servicing within the development boundary.

4.1 General Content

- N/A Executive Summary (for larger reports only).
- Date and revision number of the report.
- Location map and plan showing municipal address, boundary, and layout of proposed development.
- Plan showing the site and location of all existing services.
- Development statistics, land use, density, adherence to zoning and official plan, and reference to applicable subwatershed and watershed plans that provide context to which individual developments must adhere.
- Summary of Pre-consultation Meetings with City and other approval agencies.
- Reference and confirm conformance to higher level studies and reports (Master Servicing Studies, Environmental Assessments, Community Design Plans), or in the case where it is not in conformance, the proponent must provide justification and develop a defensible design criteria.
- Statement of objectives and servicing criteria.
- Identification of existing and proposed infrastructure available in the immediate area.
- N/A Identification of Environmentally Significant Areas, watercourses and Municipal Drains potentially impacted by the proposed development (Reference can be made to the Natural Heritage Studies, if available).

- Concept level master grading plan to confirm existing and proposed grades in the development. This is required to confirm the feasibility of proposed stormwater management and drainage, soil removal and fill constraints, and potential impacts to neighbouring properties. This is also required to confirm that the proposed grading will not impede existing major system flow paths.
- Identification of potential impacts of proposed piped services on private services (such as wells and septic fields on adjacent lands) and mitigation required to address potential impacts.
- Proposed phasing of the development, if applicable.
- Reference to geotechnical studies and recommendations concerning servicing.
- All preliminary and formal site plan submissions should have the following information:
 - Metric scale
 - North arrow (including construction North)
 - Key plan
 - Name and contact information of applicant and property owner
 - Property limits including bearings and dimensions
 - Existing and proposed structures and parking areas
 - Easements, road widening and rights-of-way
 - Adjacent street names

4.2 Development Servicing Report: Water

- Confirm consistency with Master Servicing Study, if available
- Availability of public infrastructure to service proposed development
- Identification of system constraints
- Identify boundary conditions
- Confirmation of adequate domestic supply and pressure
- Confirmation of adequate fire flow protection and confirmation that fire flow is calculated as per the Fire Underwriter's Survey. Output should show available fire flow at locations throughout the development.
- Provide a check of high pressures. If pressure is found to be high, an assessment is required to confirm the application of pressure reducing valves.
- N/A Definition of phasing constraints. Hydraulic modeling is required to confirm servicing for all defined phases of the project including the ultimate design
- Address reliability requirements such as appropriate location of shut-off valves
- N/A Check on the necessity of a pressure zone boundary modification.

- Reference to water supply analysis to show that major infrastructure is capable of delivering sufficient water for the proposed land use. This includes data that shows that the expected demands under average day, peak hour and fire flow conditions provide water within the required pressure range
- Description of the proposed water distribution network, including locations of proposed connections to the existing system, provisions for necessary looping, and appurtenances (valves, pressure reducing valves, valve chambers, and fire hydrants) including special metering provisions.
- N/A Description of off-site required feeder mains, booster pumping stations, and other water infrastructure that will be ultimately required to service proposed development, including financing, interim facilities, and timing of implementation.
- Confirmation that water demands are calculated based on the City of Ottawa Design Guidelines.
- Provision of a model schematic showing the boundary conditions locations, streets, parcels, and building locations for reference.

4.3 Development Servicing Report: Wastewater

- Summary of proposed design criteria (Note: Wet-weather flow criteria should not deviate from the City of Ottawa Sewer Design Guidelines. Monitored flow data from relatively new infrastructure cannot be used to justify capacity requirements for proposed infrastructure).
- Confirm consistency with Master Servicing Study and/or justifications for deviations.
- Consideration of local conditions that may contribute to extraneous flows that are higher than the recommended flows in the guidelines. This includes groundwater and soil conditions, and age and condition of sewers.
- Description of existing sanitary sewer available for discharge of wastewater from proposed development.
- Verify available capacity in downstream sanitary sewer and/or identification of upgrades necessary to service the proposed development. (Reference can be made to previously completed Master Servicing Study if applicable)
- Calculations related to dry-weather and wet-weather flow rates from the development in standard MOE sanitary sewer design table (Appendix 'C') format.
- Description of proposed sewer network including sewers, pumping stations, and forcemains.

- N/A Discussion of previously identified environmental constraints and impact on servicing (environmental constraints are related to limitations imposed on the development in order to preserve the physical condition of watercourses, vegetation, soil cover, as well as protecting against water quantity and quality).
- N/A Pumping stations: impacts of proposed development on existing pumping stations or requirements for new pumping station to service development.
- N/A Forcemain capacity in terms of operational redundancy, surge pressure and maximum flow velocity.
- N/A Identification and implementation of the emergency overflow from sanitary pumping stations in relation to the hydraulic grade line to protect against basement flooding.
- Special considerations such as contamination, corrosive environment etc.

4.4 Development Servicing Report: Stormwater Checklist

- Description of drainage outlets and downstream constraints including legality of outlets (i.e. municipal drain, right-of-way, watercourse, or private property)
- Analysis of available capacity in existing public infrastructure.
- A drawing showing the subject lands, its surroundings, the receiving watercourse, existing drainage patterns, and proposed drainage pattern.
- Water quantity control objective (e.g. controlling post-development peak flows to pre-development level for storm events ranging from the 2 or 5 year event (dependent on the receiving sewer design) to 100 year return period); if other objectives are being applied, a rationale must be included with reference to hydrologic analyses of the potentially affected subwatersheds, taking into account long-term cumulative effects.
- Water Quality control objective (basic, normal or enhanced level of protection based on the sensitivities of the receiving watercourse) and storage requirements.
- Description of the stormwater management concept with facility locations and descriptions with references and supporting information.
- N/A Set-back from private sewage disposal systems.
- N/A Watercourse and hazard lands setbacks.
- Record of pre-consultation with the Ontario Ministry of Environment and the Conservation Authority that has jurisdiction on the affected watershed.
- N/A Confirm consistency with sub-watershed and Master Servicing Study, if applicable study exists.

- Storage requirements (complete with calculations) and conveyance capacity for minor events (1:5 year return period) and major events (1:100 year return period).
- N/A Identification of watercourses within the proposed development and how watercourses will be protected, or, if necessary, altered by the proposed development with applicable approvals.
- Calculate pre and post development peak flow rates including a description of existing site conditions and proposed impervious areas and drainage catchments in comparison to existing conditions.
- N/A Any proposed diversion of drainage catchment areas from one outlet to another.
- Proposed minor and major systems including locations and sizes of stormwater trunk sewers, and stormwater management facilities.
- N/A If quantity control is not proposed, demonstration that downstream system has adequate capacity for the post-development flows up to and including the 100-year return period storm event.
- N/A Identification of potential impacts to receiving watercourses
- N/A Identification of municipal drains and related approval requirements.
- Descriptions of how the conveyance and storage capacity will be achieved for the development.
- 100 year flood levels and major flow routing to protect proposed development from flooding for establishing minimum building elevations (MBE) and overall grading.
- N/A Inclusion of hydraulic analysis including hydraulic grade line elevations.
- Description of approach to erosion and sediment control during construction for the protection of receiving watercourse or drainage corridors.
- N/A Identification of floodplains – proponent to obtain relevant floodplain information from the appropriate Conservation Authority. The proponent may be required to delineate floodplain elevations to the satisfaction of the Conservation Authority if such information is not available or if information does not match current conditions.
- N/A Identification of fill constraints related to floodplain and geotechnical investigation.

4.5 Approval and Permit Requirements: Checklist

The Servicing Study shall provide a list of applicable permits and regulatory approvals necessary for the proposed development as well as the relevant issues affecting each approval. The approval and permitting shall include but not be limited to the following:

- N/A Conservation Authority as the designated approval agency for modification of floodplain, potential impact on fish habitat, proposed works in or adjacent to a watercourse, cut/fill permits and Approval under Lakes and Rivers Improvement Act. The Conservation Authority is not the approval authority for the Lakes and Rivers Improvement Act. Where there are Conservation Authority regulations in place, approval under the Lakes and Rivers Improvement Act is not required, except in cases of dams as defined in the Act.
- N/A Application for Certificate of Approval (CofA) under the Ontario Water Resources Act.
- N/A Changes to Municipal Drains.
- Other permits (National Capital Commission, Parks Canada, Public Works and Government Services Canada, Ministry of Transportation etc.)

4.6 Conclusion Checklist

- Clearly stated conclusions and recommendations
- Comments received from review agencies including the City of Ottawa and information on how the comments were addressed. Final sign-off from the responsible reviewing agency.
- All draft and final reports shall be signed and stamped by a professional Engineer registered in Ontario