

- GENERAL NOTES:**
- All dimensions are in metres; all elevations are in metres and are geodetic. TBM = top of spindle of existing fire hydrant on Trailsege Way. Elevation = 85.68. Geodetic datum reference: COVD-1928/1978.
  - This is not a legal survey. Boundary and topographic information were derived from FARLEY, SMITH & DENIS SURVEYING LTD File No. 253-17.
  - Contractor is responsible for location and protection of utilities.
  - All dimensions to be verified on site by contractor prior to construction.
  - Any changes made to this plan must be verified and approved by Kollaard Associates Inc.
  - Client is responsible for acquiring all necessary permits. This drawing is not for construction until a building permit has been granted.
  - The proposed grades have been set and verified for site grading control only. The grade raise at the building location should be verified with regard to subsurface conditions by qualified geotechnical personnel after completion of the excavation.
  - The underside of footing installation has been set based on the information available and may not have accounted for actual ground water conditions at the exact house location and should be verified by qualified geotechnical personnel upon completion of the excavation.
  - A geotechnical engineer should be retained to provide recommendations with respect to the sub-grade conditions prior to footing installation.
  - The owner agrees to prepare and implement an erosion and sediment control plan to the satisfaction of the City of Ottawa, appropriate to the site conditions, prior to undertaking any site alterations (filling, grading, removal of vegetation, etc.) and during all phases of site preparation and construction in accordance with the current Best Management Practices for Erosion and Sediment Control such as, but not limited to installing filter cloth across manhole/catchbasin lids to prevent sediments from entering structures and install and maintain a light duty silt fence barrier as required.
  - All materials and construction to be in accordance with City of Ottawa standards and Ontario Provincial Standards and Specifications; sewer and watermain material types; disinfection, provide minimum 2.4 metres of cover for water services; cathodic protection; City of Ottawa insulation specifications for watermain, pipe bedding, reinstatement of disturbed areas and leakage testing. Reference to Kollaard File No. 190867 for Servicing and Stormwater Management Design and Geotechnical Reports.

No.	REVISION ITEM / DESCRIPTION	REV. DATE	INT.
5	REVISIONS PER 3rd REVIEW COMMENTS	AUG. 15/2022	ML
4	REVISIONS PER NEW SITE PLAN AND REVIEW COMMENTS	APR. 13/2022	ML
3	ISSUED FOR SPC RE-SUBMISSION	APR. 22/2021	ML
2	REVISIONS PER SITE PLAN AND 1ST REVIEW COMMENTS	MAR. 29/2021	ML
1	ISSUED FOR SPC APPLICATION	JUNE 30/2020	ML

**Kollaard Associates Engineers**  
 (613) 860-0923  
 info@kollaard.ca  
 P.O. BOX 189, 210 PRESCOTT ST.  
 KEMPTVILLE, ONTARIO  
 K0G 1J0 FAX (613) 258-0475  
 http://www.kollaard.ca

**CLIENT:**  
 TEAK DEVELOPMENTS  
 31 WOODVIEW CRESCENT  
 OTTAWA, ON K1B 3B1

**PROJECT:**  
 PROPOSED RESIDENTIAL DEVELOPMENT

**LOCATION:**  
 6173 RENAUD ROAD  
 CITY OF OTTAWA, ON  
 K1W 0K9

DESIGNED BY: SD	CHECKED BY: SD
DRAWN BY: ML	APPROVED BY: SD
DATE: NOV. 11, 2019	
KOLLAARD FILE NUMBER: 190867	

DRAWING NUMBER: 190867-GEC  
 DRAWING NAME: SITE GRADING AND EROSION CONTROL PLAN

#18196

**LEGEND**

EXISTING ELEVATION	EXISTING UTILITY POLE
PROPOSED/EXISTING ELEVATIONS	FIRE HYDRANT
PROPOSED CURB ELEVATION	PROPOSED LAMP POST
PROPOSED ELEVATION AT BUILDING ENTRANCE	PROPOSED CURB STOP
DRAINAGE SLOPE	PROPOSED WATER METER
PROPOSED BOARD FENCE	PROPOSED REMOTE WATER METER
WATERMAIN	SANITARY SERVICE CONNECTION
STORM SEWER	SUMP LOCATION
SANITARY SEWER	PROPOSED DOWNSPOUT LOCATION
TOP OF SLOPE	EXISTING WATER STAND POST
PROPERTY LINE	EXISTING WATER VALVE
OVERHEAD WIRES	EXISTING STORM MANHOLE
SILT FENCE	EXISTING SANITARY MANHOLE
PROPOSED DEPRESSED CURB	EXISTING CATCH BASIN
PROPOSED SHALE	PROPOSED REAR-YARD CB
OVERLAND FLOW ROUTE	PROPOSED CATCH BASIN/MANHOLE
LOCATION OF EXISTING SERVICE CONNECTIONS	PROPOSED CATCH BASIN
TEMPORARY BENCHMARK	PROPOSED STORM MANHOLE
	PROPOSED SANITARY MANHOLE

- GRADING NOTES:**
- ALL TREES ON THE RIGHT-OF-WAY ARE TO BE MAINTAINED BEFORE AND AFTER THE CONSTRUCTION AND ALL EXISTING TREES WITHIN THE PROPERTY SHALL BE PROTECTED AS PER "MUNICIPAL TREES AND NATURAL AREAS PROTECTION BY-LAW" AND THE "URBAN TREES CONSERVATION BY-LAW" AS AMENDED FROM TIME TO TIME.
  - NO EXCESS DRAINAGE WILL BE DIRECTED TOWARDS THE NEIGHBOURING PROPERTIES DURING AND AFTER CONSTRUCTION.
  - ALL RETAINING WALLS TO HAVE MINIMUM 0.15 METRE CLEARANCE FROM PROPERTY LINE.
  - EAVES TROUGHS TO BE DIRECTED TO THE GROUND SURFACE 1.2 METRES FROM FOUNDATION EXCEPT AS INDICATED.
  - THERE IS TO BE NO ALTERATION TO THE EXISTING GRADE AND DRAINAGE PATTERNS ON THE PROPERTY LINES.

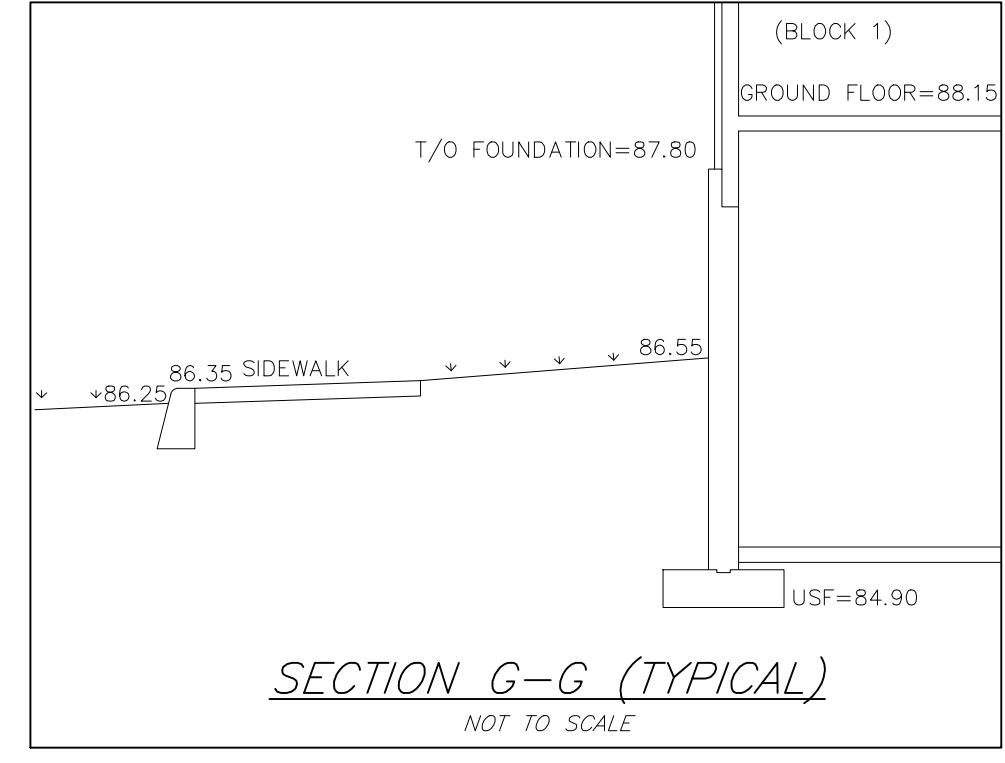
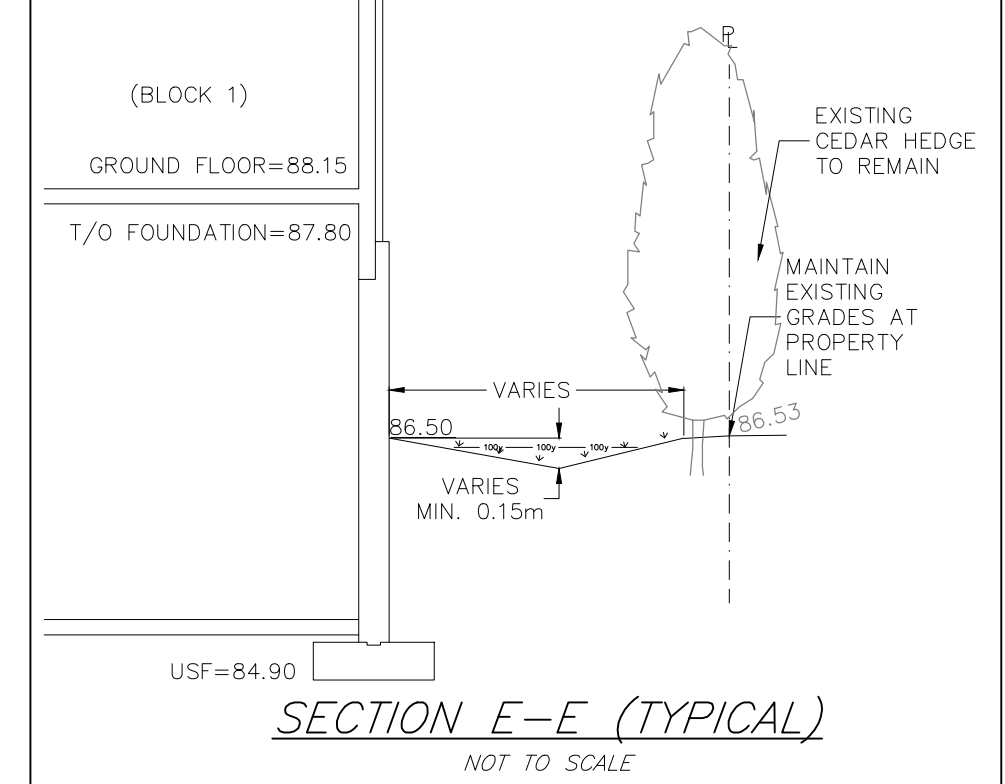
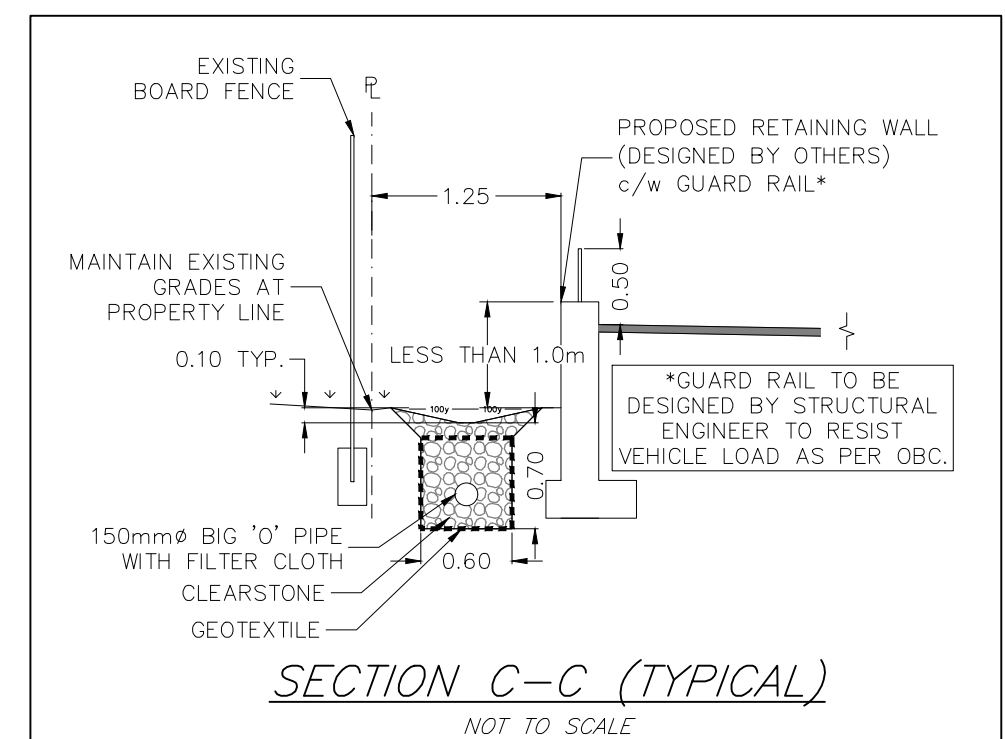

- EROSION AND SEDIMENT CONTROL NOTES:**
- THE CONTRACTOR SHALL IMPLEMENT BEST MANAGEMENT PRACTICES TO PROVIDE FOR PROTECTION OF THE AREA DRAINAGE SYSTEM AND THE RECEIVING WATERCOURSE. DURING CONSTRUCTION ACTIVITIES THE CONTRACTOR ACKNOWLEDGES THAT FAILURE TO IMPLEMENT APPROPRIATE EROSION AND SEDIMENT CONTROL MEASURES MAY BE SUBJECT TO PENALTIES IMPOSED BY ANY APPLICABLE REGULATORY AGENCY.
  - THE OWNER (AND/OR CONTRACTOR) AGREES TO PREPARE AND IMPLEMENT AN EROSION AND SEDIMENT CONTROL PLAN AT LEAST EQUAL TO THE STATED MINIMUM REQUIREMENTS AND TO THE SATISFACTION OF THE CITY OF OTTAWA, APPROPRIATE TO THE SITE CONDITIONS, PRIOR TO UNDERTAKING ANY SITE ALTERATIONS (FILLING, GRADING, REMOVAL OF VEGETATION, ETC.) AND DURING ALL PHASES OF SITE PREPARATION AND CONSTRUCTION IN ACCORDANCE WITH THE CURRENT BEST MANAGEMENT PRACTICES FOR EROSION AND SEDIMENT CONTROL.
  - THE CONTRACTOR IS TO ENSURE THAT THE SITE ACCESS POINTS AND ADJACENT STREETS TO THE ACCESS POINTS ARE MAINTAINED AND KEPT CLEAN OF CONSTRUCTION MATERIALS SUCH AS, BUT NOT LIMITED TO MUD, DIRT, CLAY AND GRANULARS ON A DAILY BASIS OR AS NECESSARY, TO THE SATISFACTION OF THE CITY OF OTTAWA.
  - EVERY EFFORT WILL BE MADE TO ENSURE THAT ALL DISTURBED AREAS ARE TOPSOILED AND SEEDS AS SOON AS REASONABLY POSSIBLE.
  - THE SEDIMENT AND EROSION CONTROL PLAN IS A LIVING DOCUMENT WHICH MAY BE AMENDED BY ON-SITE REQUIREMENTS AT THE APPROVAL OF THE MUNICIPALITY AND THE CONSERVATION AUTHORITY.

