

SEPTEMBER 2020



planning + design

AERIAL VIEW LOOKING SOUTH



PLANNING + DESIGN RATIONALE

PARK RIVER PROPERTIES
200 BARIBEAU STREET
OTTAWA, ONTARIO

Report Date:
SEPTEMBER 2, 2020

Report Prepared for:
Baribeau Street
Development Inc



Prepared by :



Christine McCuaig, MCIP RPP

www.q9planning.com

Ottawa, ON

P : +613 850 8345

E: christine@q9planning.com

This Planning + Design Rationale is prepared in support of a Zoning By-law Amendment and a Site Plan Control Application for the proposed Baribeau Street townhome Planned Unit Development located at 200 Baribeau Street.

TABLE OF CONTENTS

1.0	<i>INTRODUCTION</i>	5
1.1	PROJECT	6
1.2	REQUIRED APPROVALS	6
2.0	<i>SITE & CONTEXT</i>	7
2.1	SITE	7
2.2	CONTEXT	10
2.3	PEDESTRIAN AND TRANSIT NETWORK	11
3.0	<i>PROPOSAL</i>	13
3.1	OVERVIEW	13
3.2	STATISTICS	15
3.3	ZONING REVIEW	15
3.4	ACCESS AND CONNECTIVITY	17
4.0	<i>POLICY AND REGULATORY CONTEXT</i>	18
4.1	PROVINCIAL POLICY STATEMENT	18
4.2	CITY OF OTTAWA OFFICIAL PLAN.....	20
4.3	CITY OF OTTAWA ZONING BY-LAW.....	26
4.4	URBAN DESIGN GUIDELINES FOR LOW-RISE INFILL HOUSING.....	26
5.0	<i>PROPOSED ZONING AMENDMENT</i>	29
6.0	<i>PLANNING AND URBAN DESIGN ANALYSIS</i>	30
6.1	INTENSIFICATION	30
6.2	LAND USE	30
6.3	DESIGN BRIEF	30
7.0	<i>PUBLIC CONSULTATION STRATEGY</i>	32
8.0	<i>SUPPORTING PLANS AND STUDIES</i>	33
8.1	PHASE I/II ESA	33
8.2	TRAFFIC STUDY	33
8.3	SITE SERVICING REPORT	33
9.0	<i>CONCLUSION</i>	35

1.0 INTRODUCTION

Park River Properties, owners of 200 Baribeau Street, are proposing to redevelop the subject site, identified on the location plan below, in order to construct a new residential development. The existing use is a former school. The site, located in Vanier towards the east end of the inner urban area of Ottawa, is situated in a low-rise, medium density neighbourhood, containing a mix of infill and older homes.

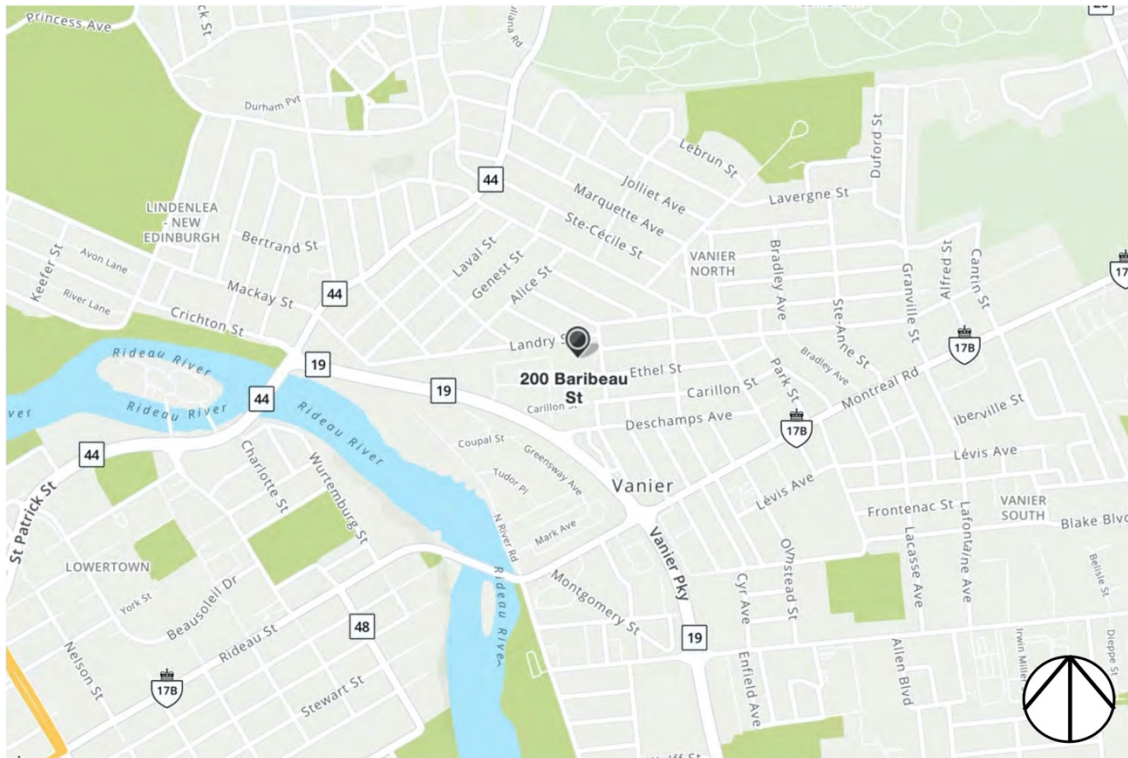

Figure 1: Location Plan

The property was purchased in March 2019. It is a large site, fronting onto Baribeau Street to the east and Landry Street to the north. It currently has a Minor Institutional Zone attributed to it which allows the existing school, along with other institutional uses. However, the area is also identified as an Area of Reduced Flood Risk and is located within the Floodplain Overlay. In this designation, at all levels of policy, institutional uses such as the existing school, are prohibited for safety reasons. Residential, however, is permitted.

This Planning + Design Rationale was prepared on behalf of Park River Properties in order to review and analyze the merits of the proposal against the context, policy framework, technical reports, and applicable guidelines. The following sets out this report.

1.1 PROJECT

The proposal is for a Planned Unit Development (PUD) featuring internal private streets to serve the proposed residential development of 92 townhomes in a mix of regular style townhomes along with back-to-back style townhomes identified for the interior of the site. Part of this proposal will include an expansion of St. Ambroise Park.

1.2 REQUIRED APPROVALS

Due to the existing institutional zoning and the flood plain overlay that currently applies to the site, a Zoning Amendment Application is required, as well as a separate application to the Rideau Valley Conservation Authority in order to address the technical aspects of developing in this special provision flood plain area. Lastly, a Site Plan Control application is required to approve the details of the proposed development.

A copy of the RVCA submission letter is attached to this document as an appendix for reference purposes. The purpose of the RVCA application is to propose a grade change on the site which will have the effect of removing the subject site from the applicable flood plain overlay. The technical merits of this grade change have been reviewed and approved in principle from the RVCA but the proposed grade change also required approval from a policy perspective. This latter component required attendance at the RVCA Executive Hearing Committee. At the meeting of August 13, 2020, the Approval in Principle for the development, including the grade raise and the exemption from one of the policies, was approved.

The procedural timeline for this development is identified below.

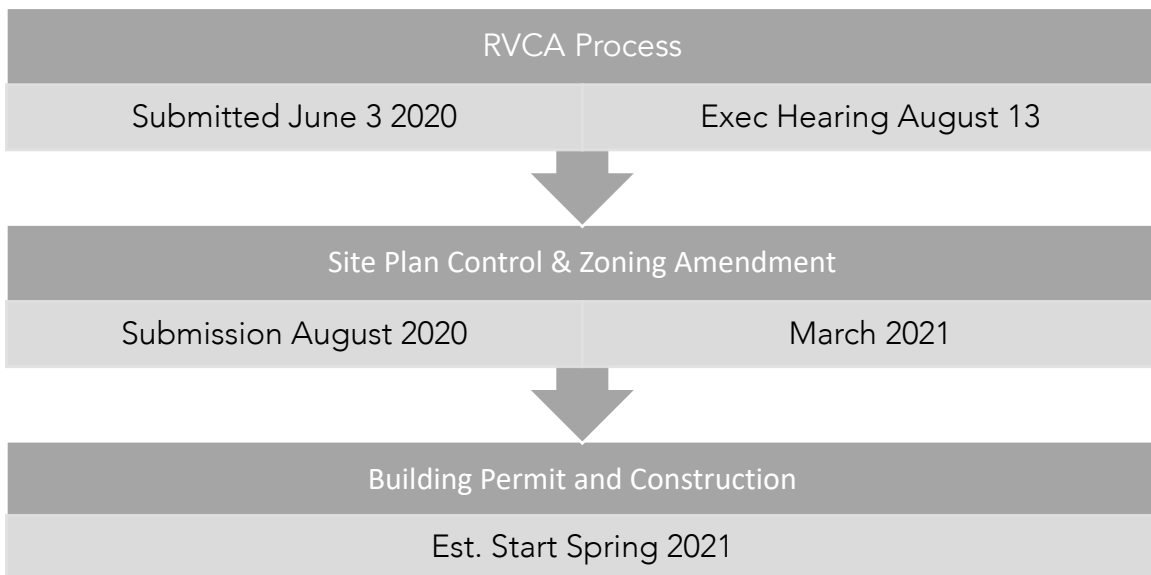

2.0 SITE & CONTEXT

2.1 SITE

The proposed site, 200 Baribeau Street, is a rectangular parcel of land (shown below) that has frontage on Baribeau Street (east) and on Landry Street (north). The majority of the site is paved or occupied by building. There is some minor vegetation along the front yard facing Baribeau Street, and a small patch of yard in the rear southwest corner of the site.



Figure 2: Subject Site

The following presents the site statistics.

- [Site Area: 12,704 m²
- [Site Frontage: 95 m (Landry Street), 130 m (Baribeau Street)
- [Site Depth: ~ 95 m east-west, ~133 m north-south
- [Legal Description: Part of Block A, Registered Plan M-44, City of Ottawa

On the following page, images of the site are provided.



Figure 3: View of site from Baribeau, looking north west into the site



Figure 4: View of site from the west property line on Baribeau Street



Figure 5: View of site from the intersection of Baribeau Street and Landry Street, looking northwest into the site.



Figure 6: View into the site from Landry Street, looking west



Figure 7: Birds eye view of subject site

2.2 CONTEXT

The subject site, as noted, is situated within the community of Vanier North, a neighbourhood located at the east end of the inner urban area of Ottawa, as shown on the map below. This area contains a large francophone community, and despite the size of the neighbourhood, the population density is representative of an inner urban community.

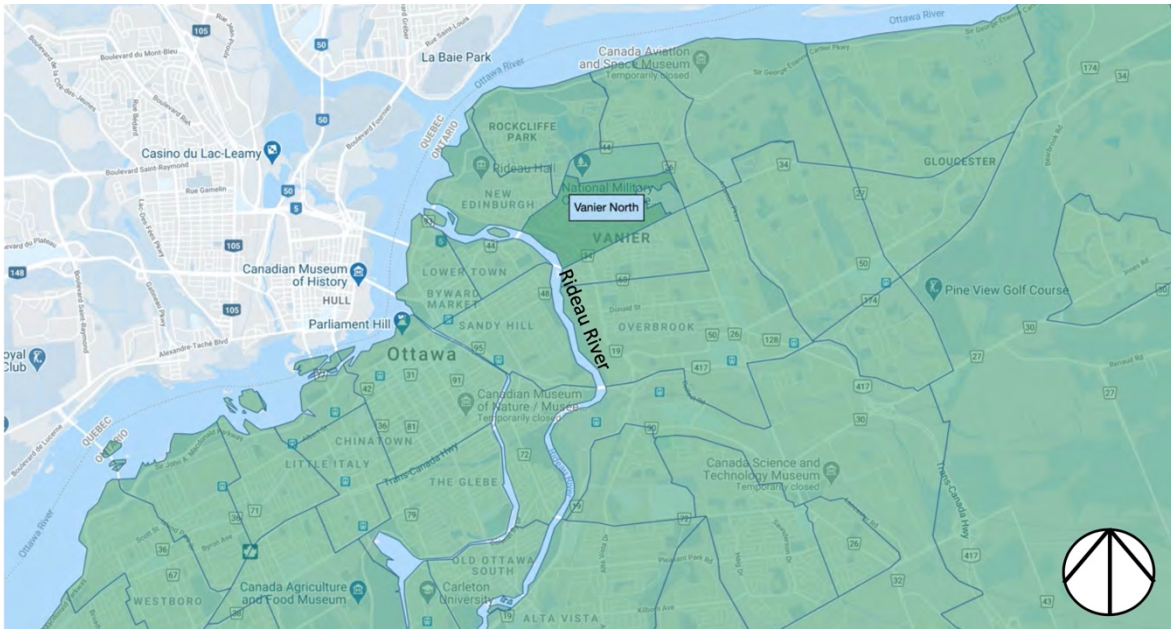

Figure 8: Location of Context (Vanier North)

The subject site, within Vanier North, is situated east of Vanier Parkway, north of Montreal Road, and south of Beechwood Avenue. Due to its proximity to the east bank of the Rideau River, it is captured within a flood plain overlay. Despite the flood plain overlay identified for this area, it is densely built up with ground-oriented residential. Development in this special flood plain area is possible due to it being classified as an area of reduced flood risk, for the reason that there is a structured berm (NCC Pathway) west of Kingsview Park that offers protection from flood events caused by a rising Rideau River.

Lot and Road Pattern

The community presents a fairly standard grid pattern of roads and blocks, some angled. Lots are typically 330 m², with 10-12 metres frontages. This lot pattern enables the two-storey single detached home with a side yard driveway and parking space that is typical of this community.

Architectural Style

The architectural style and materiality of Vanier North is due to its historical status as a working-class community. Along the nearby street of Dagmar Avenue, for example, the original style and cladding of homes is truly representative of the communities past. Typical dwellings have peaked roofs, white siding, occasionally beige brick or other light stone-type material. It is also common to see red brick facades on multi-unit residential buildings.

Infill development has provided variety of architectural style and offered a greater variety of unit types, such as the infusion of more triplexes and semi-detached dwellings.

2.3 PEDESTRIAN AND TRANSIT NETWORK

The pedestrian and transit network is representative of an inner urban neighbourhood which consists of local and collector roads. The following diagram depicts where roads have sidewalks on both sides, and all cycling routes. A 500 m radius is the equivalent of a less than 10-minute walk. The map on the following page identifies the nearest bus stops.



Figure 9: Map showing 500 m radius of Pedestrian and Cycling Context

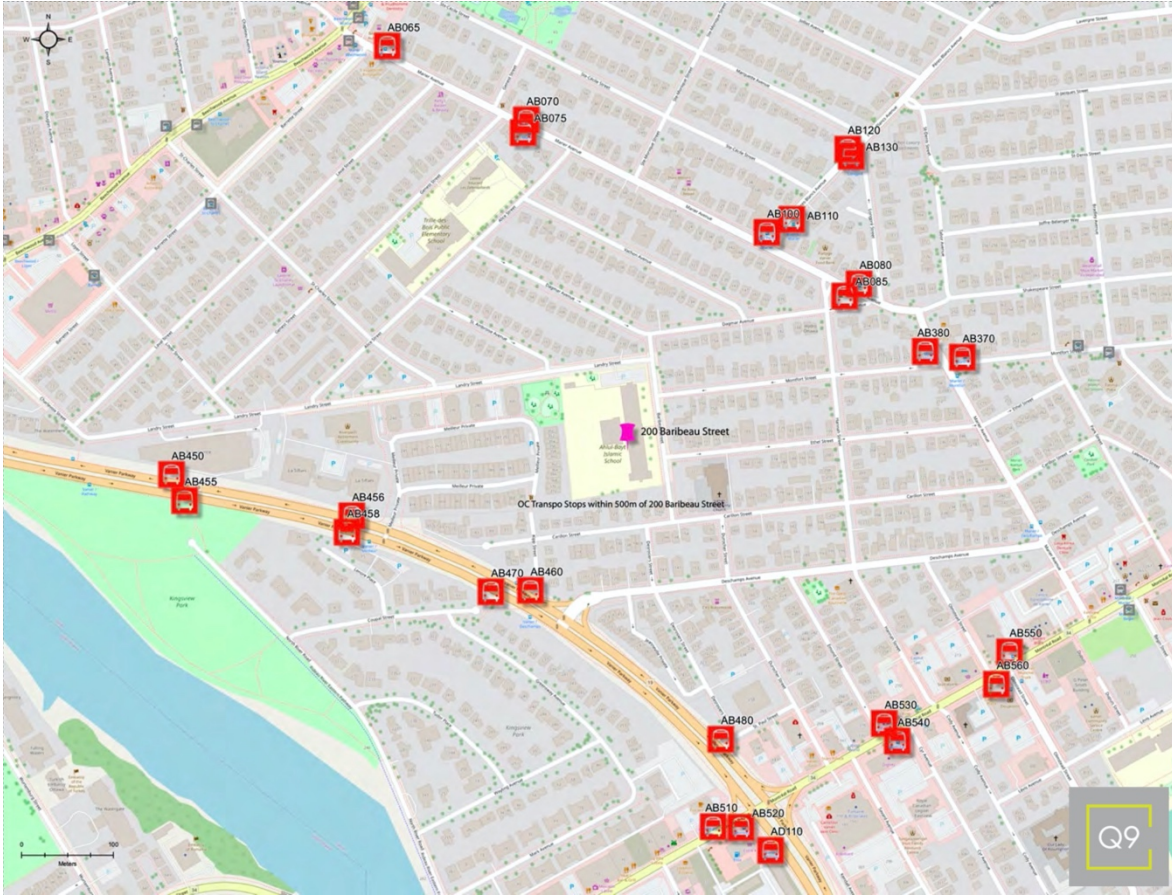

Figure 10: GIS Map showing OC Transpo Bus Stops within 500 m Radius

3.0 PROPOSAL

3.1 OVERVIEW

The proposed development is for 92 units in a mix of standard style townhomes (50) and back-to-back townhomes (42). It will be designed as a Planned Unit Development (PUD) with private roadways that meet the minimum of 6.0 metres as per Section 131 of the Zoning By-law. See the proposed 3D plan prepared by Hobin Architects below. Full Site Plan and elevations are provided as Appendix A.



Figure 11: 3D Render of Proposed Site Plan

In addition to raising the grade to allow for the safe development of this project, the proposed residential infill will be constructed as slab-on-grade, and will meet all flood-proofing standards as well as safe access standards.

The underside of the slab will be at least 300 mm above the 1:100 year flood level in accordance with RVCA policies. Further, safe access for the private roadways will meet RVCA requirements and ensure water levels are never greater than 0.30 m.

All accesses to the dwellings, included front entryways and garages will be 300 mm above the 1:100 year flood level.

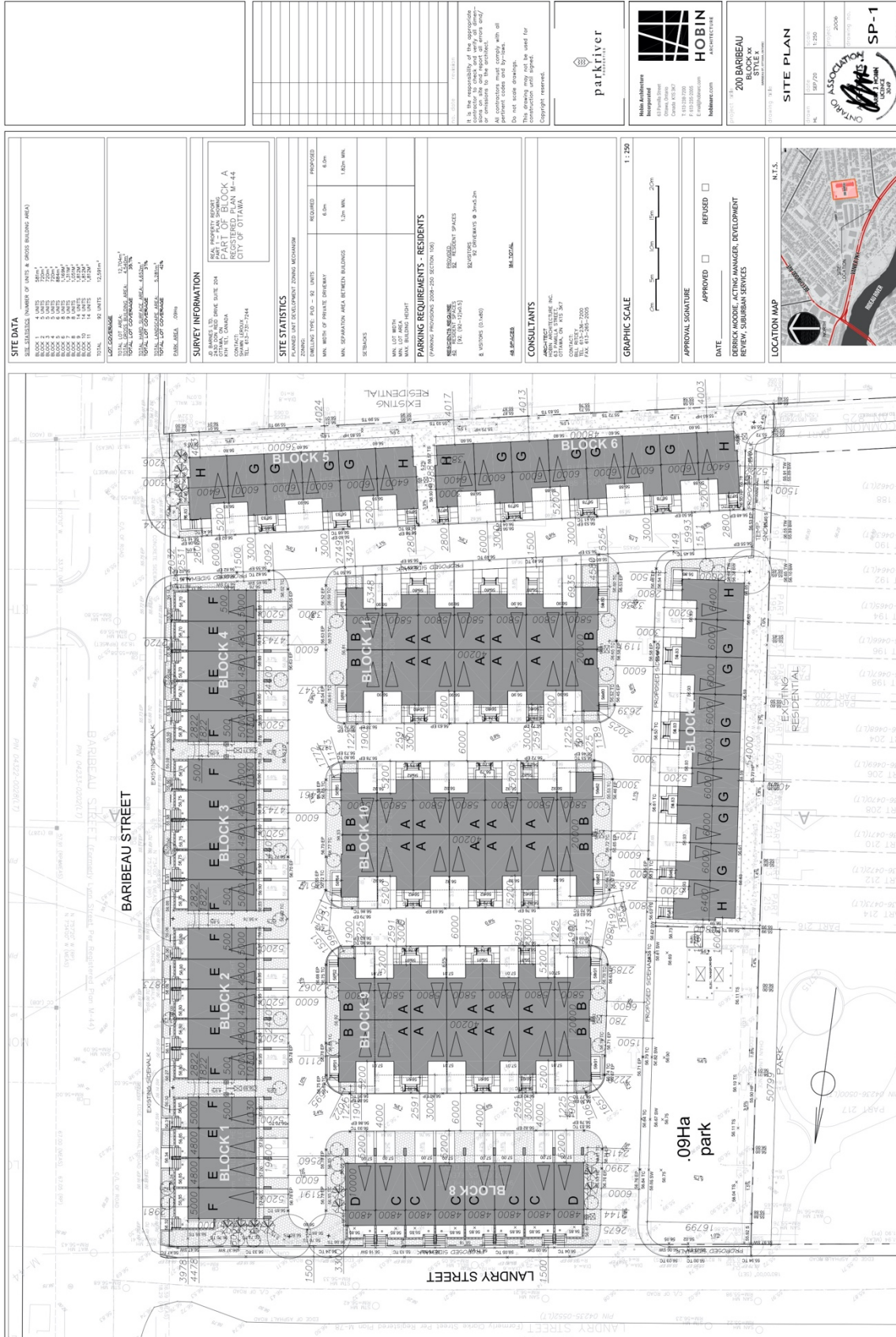

Figure 12: Site Plan prepared by Hobin Architecture

3.2 STATISTICS

The chart on the following page details the statistics of the proposal, park size, number of roads and access points, as well as specifying the gross building area and total landscaped area, which includes the park.

Table 1: Development Statistics

	NO.	SIZE / GFA
Units	92	12,591 m ²
Park	1	0.09 ha
Roads	6	4,652 m ²
Gross Building Area	4,540 m ² (35.7 %)	
Landscaped Area	5,281 m ² (42%)	

3.3 ZONING REVIEW

In comparing required and proposed zoning statistics, the table below assumes the zoning amendment, as being requested, to be a standard R4 zone where a Planned Unit Development (PUD) is permitted. Where the proposed development does not meet any of the R4 provisions, it has been noted in **bolded** text.

Table 2: Zoning Review

	REQUIRED	PROPOSED	NOTES
Lot Area	1400 m ²	12,704 m ²	
Lot Width	n/a	n/a	
Maximum Building Height	11 m		
Front Yard Setback	3 m	2.72 m (Baribeau)	
Corner Yard Setback	3 m	3.3 m (Landry)	
Minimum Rear Yard Setback (south and west yards)	7.5 m (As per R4K, Table 162B- Note 4)	4 m	Townhomes in R4K are required to provide 25% of lot depth. The average lot depth is 16 m, resulting in a required setback of 4 m. Lots that are a depth of 15 m or less must have a minimum of 4.0 m rear yard.
Minimum Interior Yard Setback	1.2 m (As per R4K, Table 162B – Note 1(a) – As per dwelling type proposed)	1.2 m and 5.2 m	Areas where this provision is applicable is north end of Block 7 and west end of Block 6
Minimum Width of Private Way	6.0 m	6.0 m	

Minimum setback for any wall of a residential use building to a private way	1.8 m	1.2 m	The 1.2 m setback from building to a private way only applies directly at the corners. The interior corner yard setbacks from private ways exceeds 1.8 m
Minimum Setback of a garage or carport entrance from a Private Way	5.2 m	5.2 m	
Minimum Separation between buildings in a PUD	1.2 m	1.82	Please note that this setback is applied between the buildings in a PUD and not the interior yard setback provision

3.4 ACCESS AND CONNECTIVITY

The proposed development features two vehicular access points (green arrows), as identified below. Both are positioned as far away from the intersection of Baribeau Street and Landry Street as feasible to minimize conflict of vehicular movements and any queueing that may occur during peak periods. There is an existing sidewalk (red dashed line) along Baribeau Street which is to be maintained and reinstated following construction as needed. Proposed sidewalk locations (black dashed line) will be along Landry Street where no sidewalk currently exists and along Private Way No. 3 where it passes the park and continues south to connect to an existing pathway in the abutting PUD development to the west.



Figure 13: Site Plan Markup showing Accesses and Connectivity

4.0 POLICY AND REGULATORY CONTEXT

4.1 PROVINCIAL POLICY STATEMENT

Section 1.1.1 of the PPS sets out the parameters for establishing healthy, liveable and safe communities. The overarching theme of these policies is to promote efficiency, both financially and environmentally, and to accommodate housing to meet long term needs of the municipality. See the detailed list of criteria for achieving a healthy, liveable and safe community:

- [The promotion of efficient development that supports financial stability;
- [Accommodating an appropriate range and mix of residential and other uses;
- [Avoiding unsafe or unhealthy development patterns;
- [Cost-effective developments;
- [Promoting growth management and transit-supportive development, intensification and infrastructure planning to achieve cost-effective development patterns.
- [Improving accessibility;
- [Conserving biodiversity; and
- [Preparing for regional and local impacts of a changing climate

Comment

The proposed development remedies an unsafe, non-compliant situation and provides an opportunity for residential infill in an existing built community where new development can benefit from existing infrastructure.

Quality, well designed intensification at this location is a way to achieve the items identified in Section 1.1.1 of the PPS 2020. Most notably, the pursuit of growth management. The City of Ottawa has recently approved an expansion to the current urban boundary. In order to reduce the demand for extension of settlement areas, intensification should be promoted and supported within existing built communities where land is available.

Section 1.4 - Housing

In Section 1.4, *Housing*, municipalities must maintain at all times the ability to accommodate growth for a minimum of 10 years through intensification and redevelopment primarily. Only, if necessary, should a municipality designate land available for growth. Further, this accommodation of growth should occur in a way that offers a range and mix of housing options and densities.

As noted in Section 2.2 of this report, the majority of existing unit types in this community are two-storey single-detached homes, with some semi-detached buildings, triplexes, and fourplexes. While new development and redevelopment have broadened the availability of other dwelling types, there is still opportunity to offer greater variety which translates to a range of affordability.

Further, the proposed development conforms to the PPS by providing redevelopment and intensifying a parcel of land within existing infrastructure that does not create an unsafe situation, but remedies one. Elevating the site out of the 1:100 year flood level is a non-issue due to the fact that the current area is protected by the existing NCC Pathway which has been constructed above the 1:100 flood level. There is existing development in the area currently, and by removing a school from the flood plain, the situation is being improved.

Section 1.7 Long-term Economic Prosperity

In this section, provision (f) promotes the redevelopment of contaminated sites. This subject property, as noted in the Phase I/II ESA contains some contamination from the oil furnace of the former school and, therefore, cleanup is required.

Section 3.1 Natural Hazards

Policy 3.1.5 indicates that certain development shall not be permitted to locate in hazardous lands (e.g. hazardous lands adjacent to river, stream and small inland lake systems which are impacted by flooding hazards and/or erosion hazards) where the use is a) an institutional use, such as a school.

While the Kingsview Park area may not be entirely considered hazardous lands due to the special provision area being an Area of Reduced Flood Risk, there is still a moderate risk and if any use is to be present on this site, a school is one of the least acceptable uses to be established.

The proposed residential development, and necessary grade-raise for the site, is more compliant with the intents and purposes of the PPS policies than the existing situation.

4.2 CITY OF OTTAWA OFFICIAL PLAN

The site is designated General Urban Area. Section 3.6.1 of the Official Plan sets out the policies for this designation. Policy 5, noted below, states that the City supports intensification in the General Urban Area where it will complement the existing pattern and scale of development and planned function for the area. The predominant form of development and intensification is to be ground-oriented multi-unit housing.

Section 3.6.1 – General Urban Area

Policy 5 | The City supports intensification in the General Urban Area where it will complement the existing pattern and scale of development and planned function of the area. The predominant form of development and intensification will be semi-detached and other ground-oriented multiple unit housing. When considering a proposal for residential intensification through infill or redevelopment in the General Urban Area, the City will:

- 1) Assess the compatibility of new development as it relates to existing community character so that it enhances and builds upon desirable established patterns of built form and open spaces;
- 2) Consider its contribution to the maintenance and achievement of a balance of housing types and tenures to provide a full range of housing for a variety of demographic profiles throughout the General Urban Area; [Amendment #150, LPAT July 18, 2019]

Comment

The proposed townhouse development is comparable density to the existing area. It is a proposed R4 zone. Surrounding zones consist of R4 and R5 in some cases. Further, it is notable that the City is currently looking to expand the permissions of the R4 zones in order to promote suitable increases in density. The proposed development offers suitable density in a unit type that will provide additional residential variety to an existing built community in the inner urban area.

The proposed design of the townhomes is representative of existing colours and textures used in the area. Further, there are few examples of townhomes in the Vanier community. In order to be consistent with Policy 5 as identified above, providing more variety of ground-oriented homes is recommended.

Section 2.2.2 Managing Intensification Within the Urban Area

"[...] The policy direction of this Plan is to promote an efficient land-use pattern within the urban area through intensification [...].

The applicable policies to the proposed development include:

Policy 1 | "Residential intensification means intensification of a property, building or area that results in a net increase in residential units or accommodation and includes:

- b. The development of vacant or underutilized lots within previously developed areas, being defined as adjacent areas that were developed four or more years prior to new intensification; and,
- c. Infill development.

Policy 3 | All intensification will occur in accordance with the provisions of Section 2.5.1, Urban Design and Compatibility, and 4.11, Urban Design and Compatibility, and with Section 4.6.1, Heritage Buildings and Areas."

Intensification Outside of Target Areas

Policy 22 | "The City also supports compatible intensification within the urban boundary, including areas designated General Urban Area. The City will promote opportunities for intensification in areas determined by the policies in Section 3.6.1. Intensification that is compatible with the surrounding context will also be supported on: **brownfield sites** that have been remediated; on **underdeveloped sites** such as current or former parking lots; in extensive areas previously used for outside storage; **sites that are no longer viable for the purpose for which they were originally used** or intended; and on sites of exhausted pits and quarries in the urban area where the urban design. [Amendment #150, LPAT July 18, 2019]" **[emphasis added]**

Policy 23 | "The interior portions of established low-rise residential neighbourhoods will continue to be characterized by low-rise buildings (as defined in Figure 2.4). The City supports intensification in the General Urban Area where it will enhance and complement its desirable characteristics and long-term renewal. Generally, new development, including redevelopment, proposed within the interior of established neighbourhoods will be designed to complement the area's desirable character reflected in the pattern of built form and open spaces. The character of a community may be expressed in its built environment and features such as building height, massing, the setback of buildings from the property line, the use and treatment of lands abutting the front lot line, amenity area landscaped rear yards, and the location of parking and vehicular access to individual

properties. The City will consider these attributes in its assessment of the compatibility of new development within the surrounding community when reviewing development applications or undertaking comprehensive zoning studies. [Amendment #150 LPAT July 18, 2019]”

Comment

As per policy 22, the proposed development is being planned on an underutilized former school site, to which the former use (e.g. a school) is no longer a viable use or a preferred use given the existing constraints of the area being within the 1:100 flood overlay zone. Further, the site requires remediation and will be remediated to permit the proposed residential development.

In response to Policy 23, the proposed development is considered a low-rise, ground-oriented residential use which is compatible with the existing density of the Kingsview Park neighbourhood. The neighbourhood is a tighter knit lot fabric but contains minimal variety of townhome dwelling types which allow for an alternate form of intensification and options for residents of a city looking to buy into a community where a single family dwelling (SFD) exceeds their budget. Townhomes are typically a more affordable option than either SFDs or semi-detached units.

In terms of compatibility, the proposed development offers front yard setbacks that are notably similar to the those in the existing community, as demonstrated in the images below of a nearby street on Carillon.

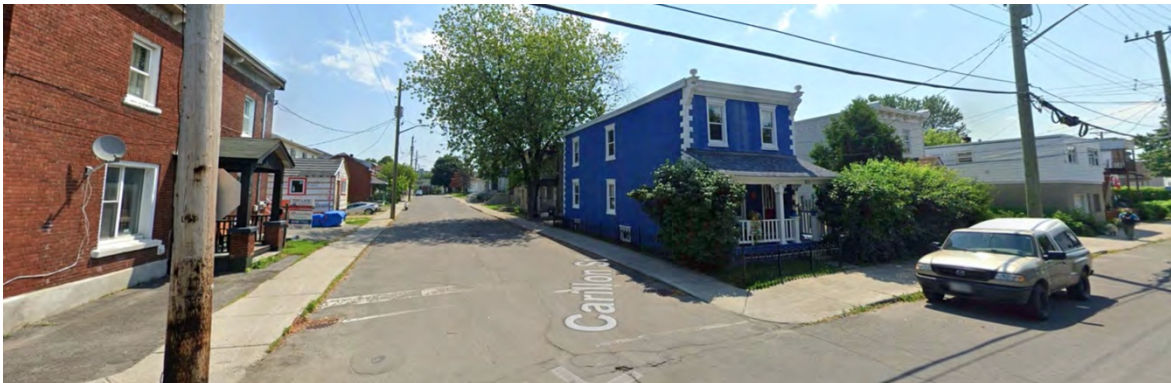

Figure 14: Image identifying front yard setback context in Vanier



Figure 15: Image 2 identifying front yard setback context in Vanier

Section 2.5.1 Urban Design and Compatibility

This section states the following: “[t]he Design Objectives of this Plan are qualitative statements of how the City wants to influence the built environment as the city matures and evolves. These Design Objectives are broadly stated, and are to be applied within all land use designations, either at the citywide level or on a site-specific basis. Design Principles further describe how the City hopes to achieve each of the Design Objectives, but may not be achieved or be achievable in all cases; these objectives include:”

- [To enhance the sense of community by creating and maintaining places with their own distinct identity;
- [To define quality public and private spaces through development;
- [To create places that are safe, accessible and are easy to get to, and move through;
- [To ensure that new development respects the character of existing areas;
- [To consider adaptability and diversity by creating places that can adapt and evolve easily over time and that are characterized by variety and choice. [OMB decision #2649, September 21, 2006];
- [To understand and respect natural processes and features in development design;
- [To maximize energy-efficiency and promote sustainable design to reduce the resource consumption, energy use, and carbon footprint of the built environment.”

Comment | The Park River towns development is aiming to establish its own distinct identity by offering more textured design and an infusion of red brick industrial style to recognize some of the existing older red-brick fourplexes in the area. The provision of a park with functional uses and proposed sidewalks ensure the development offers safe amenities and accessibility. The park is being designed and constructed in conjunction

with the proposed development to ensure a quality public space is available to meet the demands of a moderately increased neighbourhood population.

The following present some visuals of comparable design and architectural style. The upper set of images are the proposed renders of the project and the lower set of images are existing buildings within the area.



Figure 16: Design Compatibility Comparison of Proposed and Existing

Section 4.11 Urban Design and Compatibility

This section states that, “[a]t the city-wide scale, issues of compatibility are addressed in the Official Plan through the appropriate designation of land and associated policies that direct where and how certain categories of land use should be permitted to develop...

“At the scale of neighbourhoods or individual properties, issues such as noise, spillover of light, accommodation of parking and access, shadowing, and micro-climatic conditions are prominent considerations when assessing the relationships between new and existing development. Often, to arrive at compatibility of scale and use will demand a careful design response, one that appropriately addresses the impact generated by infill or intensification. Consequently, the issue of ‘context’ is a dominant theme of this Plan where it speaks to compatibility and design”.

The applicable Design Review items are discussed below.

Building Design | The proposed development offers comparable front yard setbacks, which are minimal and create a common street edge, framing the public realm. Front porch's descend steps to a walkway that connects to the public sidewalk, similar to other residential front yard patterns in the area. Vehicle parking and driveways are not provided in the areas facing Baribeau Street or Landry Street. This is to ensure the highest degree of neighbourhood character. Further, where driveways and garages are proposed internally to the PUD, their presence has been minimized by projecting the entrances towards the street and with the provision of balconies that project over the driveway space. This is an identified method of minimizing driveways and garage presences as identified in the Low-Rise Residential Infill Guidelines document.

The roof lines are flat which are consistent with the existing fourplexes in the area. The noted red brick facades of the existing fourplexes in Vanier have also been reflected in a modern interpretation within the proposed design.

Massing and Scale | The proposed townhomes are a similar density to nearby residential, where R4 and R5 zones exist. The proposed R4 zone and resulting development scale is appropriate for the context.

Outdoor Amenity Areas | In addition to the yards, front porches, and balconies provided with the proposed towns, the project provides for an extension and addition to the existing park which will serve the proposed development as well as the overall community.

Public Art | Public art is being considered for the Park River development.

Section 4.8 Protection of Health and Safety

Section 4.8.1 of the City of Ottawa Official Plan deals with Floodplain areas. Development in floodplains is permitted where new development with any site alteration does not have a negative effect on flooding, and where development and any site alteration is approved by the appropriate conservation authority.

This section essentially sets the stage for transferring authority of approvals of development within any floodplain areas towards the applicable conservation authority.

Policy 6, indicates that schools (and other institutional uses) are prohibited in the floodplain. Notwithstanding the fact that this use is likely legally non-conforming given the date of establishment, it does not detract from the fact that it is identified as an unsafe

situation and therefore should be remediated through redevelopment to a more preferable land use.

Lastly, we note that Approval in Principle from the RVCA has been provided for the proposed development.

4.3 CITY OF OTTAWA ZONING BY-LAW

As the current Institutional zoning is not a desired use for lands within the floodplain zone and requires a Zoning Amendment to permit the proposed residential, this policy section reviews the policies of *Section 58 - Floodplain Overlay* only.

Provision (3) notes that schools (among other institutional and sensitive uses) are not permitted in a flood plain overlay (including those areas of floodplain overlay identified in provision (4)).

Provision (4) notes that despite the restrictions to floodplains in Provisions (1) and (2), development other than a coach house may be permitted so long as it is carried out in accordance with flood proofing standards, protection works standards, and access standards and is approved by the appropriate Conservation Authority.

This proposed residential development, will meet the flood-proofing standards, protection works standards, and access standards. Further, it will uphold the tenants of the Conservation Authorities principles of ensuring there are no negative impacts on pollution, erosion, flooding, or conservation of land.

4.4 URBAN DESIGN GUIDELINES FOR LOW-RISE INFILL HOUSING

The City of Ottawa's guidelines for the development of low-rise residential infill are structured into four main review sections: Streetscapes, Landscape, Building Design, and Parking and Garages.

The purpose and objectives of these guidelines is to

- [Enhance streetscapes
- [Support and extend established landscaping
- [Be a more compact urban form to consume less land and natural resources
- [Achieve a good fit into an existing neighbourhood, respecting its character, and its architectural and landscape heritage
- [Provide new housing designs that offer variety, quality and a sense of identity
- [Emphasize front doors and windows rather than garages
- [Include more soft landscaping and less asphalt in front yards

- [Create at grade living spaces that promote interaction with the street
- [Incorporate environmental innovation and sustainability

Section 2.0 – Streetscape Guidelines

- [**Contribute to an inviting, safe, and accessible streetscape:** The proposed development achieves this by having principal entrances face the street and providing porches facing the street as well. Proposed sidewalks internally and externally contribute to a safe and accessible streetscape.
- [**Reflect desirable aspects of established streetscape character:** The desirable established character is represented by not locating any driveways or parking on the frontages facing Baribeau Street or Landry Street. Where driveways and garages exist internally to the development, their presence is offset by projected entrance porches and balconies.
- [**Landscaping along street:** Trees are proposed where soil volume and depth is available and generous landscaping provided everywhere possible, including locations for container planters.

Section 3.0 - Landscape

- [**Reflect landscaping pattern and materials of surrounding homes:** The current pattern and materials for the front yard patterns are a mix of soft landscaping and porches in very small front yard setbacks. There are also a fair number of instances of front yard parking in this community. The proposed porches and careful landscaping of shrubs and planter beds, along with trees where possible, is a desirable landscape pattern and character for the area.
- [**Plant trees, shrubs, and ground cover adjacent to the public street and sidewalk for an attractive sidewalk edge:** The project provides trees, shrubs and other landscaping components along the public streets to improve the sidewalk edge condition.
- [**In order to enhance a sense of separation when infill is close to the street, use planting and/or low fencing to define the boundary between the public space of the street and the semi-public space of the front yard:** The proposed grade change towards the edges of the site necessitate a situation of a porch, stairs, and a lowered planting bed area. The low retaining wall provides definition to the boundary between the private and public spaces.

Section 4.0 – Building Design and Built Form

- [**Siting:** As identified in other sections of this report, the proposed development has been sited to respect setbacks and character present in the neighbourhood. Notably, through reduced front yard setbacks of about 3 metres, where front porches are provided. Removing driveways and garages from the main local roads improves the character of the building's orientation and framing of the public realm. The comparisons in Figures 13 and 14 in the Design Guideline document are similarly represented for the back-to-back townhomes proposed internally. Projected balconies and entrances that protrude beyond the garage access ensure compatible and aesthetically pleasing site and design configurations.
- [**Mass/height :** The proposed mass and height are comparable to a nearby PUD development. Further, the three-storey townhomes provide a compatible intensification representative of a more urban-context style while still being able to suitably integrate into the existing community.
- [**Architectural Style and Facades :** As noted the architectural style is a reflection of the multi-unit buildings that exist in this community already that are typically flat-roofed and red-bricked. This style has been represented with modern influences to set it apart while ensuring it integrates compatibility.

Section 5.0 – Parking and Garages

The overarching theme for this section, reiterated through several related points it to minimize the presence of driveways and parking and to mitigate the visual presence of front-facing garages. Use permeable pavers where possible.

The proposed development directs garages and driveways internally to the PUD development, and where they do exist, they are the minimum standard for width and length, occupying as little space as possible. Further, access to garages has been mitigated and visually reduced through the presence of extruded porches and accesses, along with the projection of balconies over the driveway accessing the garage parking space.

The proposed driveways and garages incorporate the design guidelines effectively to minimize their presence and visual representation.

5.0 PROPOSED ZONING AMENDMENT

The proposed Zoning Amendment is to amend the zoning from the current I1A – Minor Institutional Zone, subzone A, to a R4K Exception Zone – Residential Fourth Density, along with a separate O1 zone to acknowledge the expansion of the existing park. The details of the proposed R4K Zoning Exception are provided below. Also provided is a proposed zoning map.

Urban Exceptions 2001-3000

		Exception Provisions		
I Exception Number	II Applicable Zones	III Additional Land Uses Permitted	IV Land Uses Prohibited	V Provisions
XXXX	R4K[XXXX]			Permitted front or corner yard setback to be a minimum of 2.9 m Permitted distance from a building wall to a private way in a Planned Unit Development to be 1.2 m.

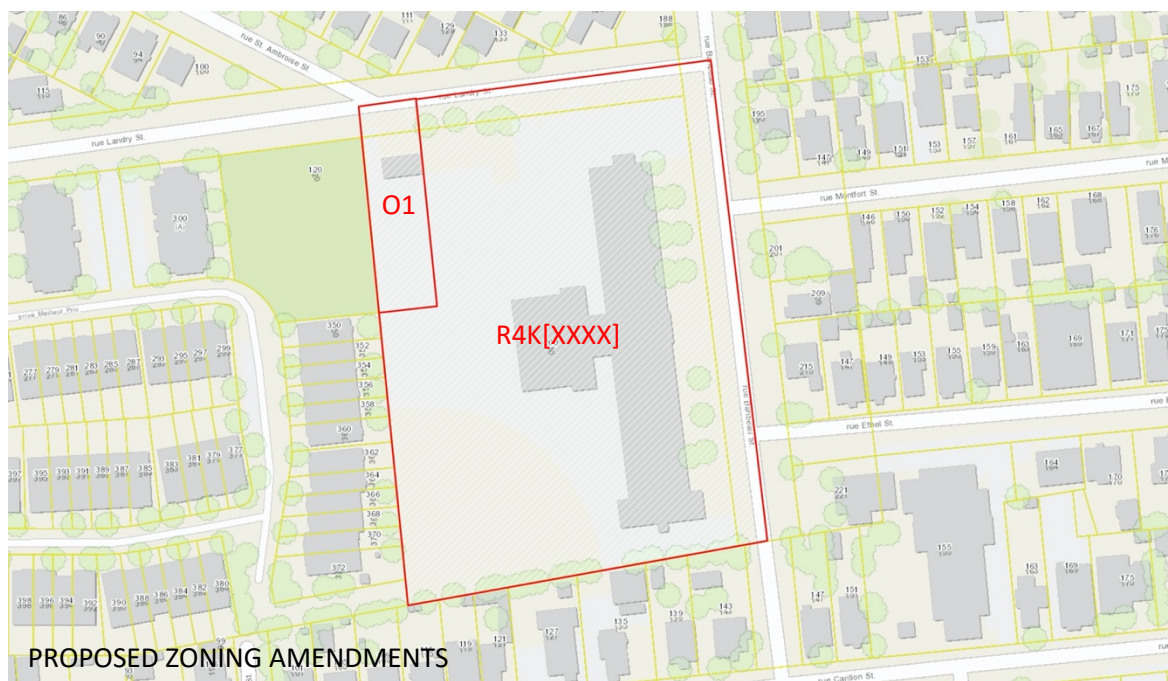

6.0 PLANNING AND URBAN DESIGN ANALYSIS

6.1 INTENSIFICATION

The proposed development is reflective of the PPS 2020 policies regarding housing and meeting the demands of population growth.

Further, the existing site is highly underutilized and does not efficiently use the available infrastructure.

The surrounding densities, reflected by the applicable zoning, are R4 and R5 typically. It is also important to note that the City of Ottawa is pursuing changes to the R4 zone in order to permit greater unit densities within currently permitted building scales and forms.

The residential PUD proposed, Park River Properties, is consistent with the majority of the zoning provisions and PUD provisions, with the exception of the front yard setback facing Baribeau Street and the distance between the corners of the internal blocks from the edge of the proposed Private Ways.

The residential intensification offers additional variety of unit type not well represented in this community offering opportunities for buy-in to the Vanier Community that may not otherwise exist for some segments of the population unable to afford single family homes located in an inner urban setting such as this.

Pressure of housing demand is a major concern and the proposed development serves to offer 92 dwellings in an inner urban setting, aligning with both provincial and municipal directions for growth management.

6.2 LAND USE

The proposed residential land use is positive change from the current institutional uses that are generally prohibited within an Area of Reduced Flood Risk in municipal policy as well as the policies of the Rideau Valley Conservation Authority.

6.3 DESIGN BRIEF

Vanier, once a gritty industrial neighbourhood, was bisected by a busy train track now replaced with the Vanier Parkway. Multiple industrial uses were scattered along this line, one of these lumberyards being directly on Landry Street. The design of these buildings borrows various historical elements from this period. This is reflected in many of the materials, such as heritage brick, rustic wood accents, and raw board formed concrete retaining walls. Mixed in with the brick cladding are large metal clad architectural

elements that contrast some of these historical elements yet maintain the industrial theme. The window frames and mullions are black and the patterning suggests one similar to historical industrial buildings found throughout the neighbourhood. The use of these various elements not only draw on the historical context of the area, but reflect the present eclectic nature of the neighbourhood that this development tries to celebrate.

The three-dimensional massing of this townhouse development is compact as it recreates a village of its own but at the same time embraces the exposures to both Baribeau and Landry streets with front yard outdoor terraces and front entrances. Garages are tucked away at the rear served by private driveways.

This development offers a variety of townhome designs that will provide a much needed stimulus to the area's housing market.

As it replaces a former institutional use this project will provide a new level of sustained activity and contribute to an already existing cohesive community.

The existing City park will be expanded into the proposed development contributing to the overall improvement of the neighbourhood.

7.0 PUBLIC CONSULTATION STRATEGY

The public consultation strategy is to conduct a public open house and community information session prior to responding to the first round of comments and recommendations provided by City and technical staff in order to allow a comprehensive response approach.

The proposed public meeting will demonstrate the proposed concept of the development to the community and request their input on components they feel reflect a desirable development and components they have concerns about.

SCHEDULED DATE FOR VIRTUAL COMMUNITY INFORMATION SESSION

SEPTEMBER 23TH AT 6:30 PM

Tools proposed for quality and engaged public consultation

- [Interactive website (www.200baribeau.ca) where comments can be submitted
- [Facilitated communication and open door policy with development team, Councillor, and Community Association group.
- [Community Information Session / Open House – September 23, 2020 @ 6:30 pm
- [Dedicated email for public comments and input.

8.0 SUPPORTING PLANS AND STUDIES

8.1 PHASE I/II ESA

Due to the assumed presence of contamination from the former school's oil furnace noted in the Phase I ESA, a Phase II ESA was prepared. The latter report was prepared by Paterson Group, dated July 5, 2019. This document outlines the type and scope of contamination and identifies that remediation will occur. Specifically, the report concludes, "Based on the findings of the Phase II ESA, fill impacted with Metals and PAHs is present on the western portion of the Phase II Property at concentrations which exceed the MECP Table 3 standards. It is our understanding that the subject site is to be redeveloped with multiple residential townhomes. It is our recommendation that an environmental site remediation program, involving the removal of all contaminated soil, be completed concurrently with the site redevelopment. Prior to off-site disposal at a registered landfill site, a representative sample of the impacted soil will require a leachate analysis, in accordance with Ontario Regulation 558, to confirm the material is non-hazardous. It is also recommended that a member of this firm be present at the time of the removal of the impacted soil in order to provide direction and to obtain confirmatory soil samples upon the completion of the remediation program."

8.2 TRAFFIC STUDY

A TIA screening report with regards to analysis of Trip Generation was prepared by Novatech, dated August 31, 2020, to determine if the project required a full Transportation Impact Assessment and it did not meet the City requirements in order to necessitate a full TIA report. As such, it is clear that there is no measurable impact of vehicles and trip generation on the surrounding community.

Schools typically add notable trip generations during peak hours and therefore the comparison of existing use versus proposed is negligible.

8.3 SITE SERVICING REPORT

A Servicing Design Brief was prepared by Novatech Engineering, dated August 24, 2020, which assessed the servicing infrastructure capacity for stormwater, watermains, sewers, and fire-fighting capacities and pressures. "The report conclusions are as follows:

- [The proposed storm system will control post-development flow to the allowable release rate of 135.6 L/s. All runoff volume from the 100-year storm event is stored on-site using underground and surface storage.
- [The proposed sanitary sewer conforms to City design criteria and provides a

gravity outlet for the development site. There is capacity in the downstream sanitary sewers to accommodate the design flow into the Baribeau Street sanitary sewers.

- [Connection to the watermains in Baribeau Street and Landry Street will provide municipal water service to the development.
- [There is adequate fire protection for the proposed development, in accordance with the Fire Underwriter's Survey.
- [The proposed infrastructure (sanitary, storm and water) complies with City of Ottawa design standards."

9.0 CONCLUSION

The proposed residential development of Park River Properties to construct 92 townhome units on an underutilized lot in an inner urban setting is recommended from a land use planning perspective for the reasons detailed in this report.

The proposed density is compatible with the surrounding designations and zones (i.e. R4 and R5). Design and architectural style provide a reflection of colours and materials used in other dwelling types in this community.

The proposed rezoning from a generally prohibited use to a preferred, safer, and permitted use is a positive planning direction for this site.

An expansion of St. Ambrose Park and the inclusion of proposed sidewalks along Landry Street and internally to the proposal offer improved amenities and accessibility for existing and future residents.

The proposed development has obtained Approval in Principle from the relevant conservation authority for the proposed site alteration being requested and the raising of the grade to elevate the site above the 1:100 year flood level. The proposal will meet all flood-proofing construction standards required as per the RVCA policies and will also meet the required Safe Access standards for the entire development, which is not presently the case today.

The development will improve the streetscape condition for this site, adding vibrancy, suitable infill, and forming a positive streetscape character by incorporating design techniques such as reorienting driveways and garages internally to the development, and where present internally, their visual presence is further mitigated by extruding pedestrian entrances and balconies.

After careful review of the proposal, documents, policies, and context, the proposed development is recommended from a planning perspective.

Prepared by :



Christine McCuaig, MCIP RPP

www.q9planning.com

Ottawa, ON

P : +613 850 8345

E: christine@q9planning.com

A handwritten signature in black ink, consisting of the initials 'CM' in a cursive, flowing script.



10.0 APPENDICES

APPENDIX A - SURVEY

APPENDIX B - SITE PLAN AND ARCHITECTURAL PACKAGE

APPENDIX C – LANDSCAPE PLAN

APPENDIX A – SURVEY

SPRINGER'S REAL PROPERTY REPORT
 PART 1 - PLAN SHOWING
 REGISTERED PLAN M-44
 CITY OF OTTAWA
 J.D. BARNES LIMITED

SCALE 1:300
 METRIC DIMENSIONS AND CONVERSIONS GIVEN ON THIS PLAN ARE TO BE TAKEN AS APPROXIMATE AND DO NOT CONSTITUTE A WARRANTY OF ACCURACY.

NOTES
 1. THIS PLAN SHOWS THE LATEST RECORDED VERSION OF THIS PLAN.

2. A COMPLETE COPIES OF THIS PLAN ARE AVAILABLE FROM THE ARCHIVES DIVISION OF THE CITY OF OTTAWA, 1500 RUELLE DES PAYSANS, OTTAWA, ONTARIO K1P 1K5.

3. THE SURVEY WAS COMPLETED ON JANUARY 20, 2020.

PART 2 - SURVEY REPORT
 THIS IS A PART OF A REGISTERED PLAN M-44 RECORDED AS PIN 04236-0200(L/T).
 THE REGISTERED PLAN M-44 IS A DEVELOPMENT PLAN FOR A CONDOMINIUM BUILDING.
 THE REGISTERED PLAN M-44 IS THE LATEST RECORDED VERSION OF THIS PLAN.
 THE SURVEY WAS COMPLETED ON JANUARY 20, 2020.
 THE SURVEY WAS CONDUCTED BY J.D. BARNES LIMITED, A PROFESSIONAL ENGINEER IN LAND SURVEYING.
 THE SURVEY WAS CONDUCTED IN ACCORDANCE WITH THE SURVEY ACT AND THE REGULATIONS MADE UNDER THEREIN.
 THE SURVEY WAS COMPLETED ON JANUARY 20, 2020.

LEGEND
 1. EXISTING CURB AND GUTTER
 2. EXISTING ASPHALT DRIVEWAY
 3. EXISTING ASPHALT DRIVEWAY
 4. EXISTING ASPHALT DRIVEWAY
 5. EXISTING ASPHALT DRIVEWAY
 6. EXISTING ASPHALT DRIVEWAY
 7. EXISTING ASPHALT DRIVEWAY
 8. EXISTING ASPHALT DRIVEWAY
 9. EXISTING ASPHALT DRIVEWAY
 10. EXISTING ASPHALT DRIVEWAY
 11. EXISTING ASPHALT DRIVEWAY
 12. EXISTING ASPHALT DRIVEWAY
 13. EXISTING ASPHALT DRIVEWAY
 14. EXISTING ASPHALT DRIVEWAY
 15. EXISTING ASPHALT DRIVEWAY
 16. EXISTING ASPHALT DRIVEWAY
 17. EXISTING ASPHALT DRIVEWAY
 18. EXISTING ASPHALT DRIVEWAY
 19. EXISTING ASPHALT DRIVEWAY
 20. EXISTING ASPHALT DRIVEWAY
 21. EXISTING ASPHALT DRIVEWAY
 22. EXISTING ASPHALT DRIVEWAY
 23. EXISTING ASPHALT DRIVEWAY
 24. EXISTING ASPHALT DRIVEWAY
 25. EXISTING ASPHALT DRIVEWAY
 26. EXISTING ASPHALT DRIVEWAY
 27. EXISTING ASPHALT DRIVEWAY
 28. EXISTING ASPHALT DRIVEWAY
 29. EXISTING ASPHALT DRIVEWAY
 30. EXISTING ASPHALT DRIVEWAY
 31. EXISTING ASPHALT DRIVEWAY
 32. EXISTING ASPHALT DRIVEWAY
 33. EXISTING ASPHALT DRIVEWAY
 34. EXISTING ASPHALT DRIVEWAY
 35. EXISTING ASPHALT DRIVEWAY
 36. EXISTING ASPHALT DRIVEWAY
 37. EXISTING ASPHALT DRIVEWAY
 38. EXISTING ASPHALT DRIVEWAY
 39. EXISTING ASPHALT DRIVEWAY
 40. EXISTING ASPHALT DRIVEWAY
 41. EXISTING ASPHALT DRIVEWAY
 42. EXISTING ASPHALT DRIVEWAY
 43. EXISTING ASPHALT DRIVEWAY
 44. EXISTING ASPHALT DRIVEWAY
 45. EXISTING ASPHALT DRIVEWAY
 46. EXISTING ASPHALT DRIVEWAY
 47. EXISTING ASPHALT DRIVEWAY
 48. EXISTING ASPHALT DRIVEWAY
 49. EXISTING ASPHALT DRIVEWAY
 50. EXISTING ASPHALT DRIVEWAY
 51. EXISTING ASPHALT DRIVEWAY
 52. EXISTING ASPHALT DRIVEWAY
 53. EXISTING ASPHALT DRIVEWAY
 54. EXISTING ASPHALT DRIVEWAY
 55. EXISTING ASPHALT DRIVEWAY
 56. EXISTING ASPHALT DRIVEWAY
 57. EXISTING ASPHALT DRIVEWAY
 58. EXISTING ASPHALT DRIVEWAY
 59. EXISTING ASPHALT DRIVEWAY
 60. EXISTING ASPHALT DRIVEWAY
 61. EXISTING ASPHALT DRIVEWAY
 62. EXISTING ASPHALT DRIVEWAY
 63. EXISTING ASPHALT DRIVEWAY
 64. EXISTING ASPHALT DRIVEWAY
 65. EXISTING ASPHALT DRIVEWAY
 66. EXISTING ASPHALT DRIVEWAY
 67. EXISTING ASPHALT DRIVEWAY
 68. EXISTING ASPHALT DRIVEWAY
 69. EXISTING ASPHALT DRIVEWAY
 70. EXISTING ASPHALT DRIVEWAY
 71. EXISTING ASPHALT DRIVEWAY
 72. EXISTING ASPHALT DRIVEWAY
 73. EXISTING ASPHALT DRIVEWAY
 74. EXISTING ASPHALT DRIVEWAY
 75. EXISTING ASPHALT DRIVEWAY
 76. EXISTING ASPHALT DRIVEWAY
 77. EXISTING ASPHALT DRIVEWAY
 78. EXISTING ASPHALT DRIVEWAY
 79. EXISTING ASPHALT DRIVEWAY
 80. EXISTING ASPHALT DRIVEWAY
 81. EXISTING ASPHALT DRIVEWAY
 82. EXISTING ASPHALT DRIVEWAY
 83. EXISTING ASPHALT DRIVEWAY
 84. EXISTING ASPHALT DRIVEWAY
 85. EXISTING ASPHALT DRIVEWAY
 86. EXISTING ASPHALT DRIVEWAY
 87. EXISTING ASPHALT DRIVEWAY
 88. EXISTING ASPHALT DRIVEWAY
 89. EXISTING ASPHALT DRIVEWAY
 90. EXISTING ASPHALT DRIVEWAY
 91. EXISTING ASPHALT DRIVEWAY
 92. EXISTING ASPHALT DRIVEWAY
 93. EXISTING ASPHALT DRIVEWAY
 94. EXISTING ASPHALT DRIVEWAY
 95. EXISTING ASPHALT DRIVEWAY
 96. EXISTING ASPHALT DRIVEWAY
 97. EXISTING ASPHALT DRIVEWAY
 98. EXISTING ASPHALT DRIVEWAY
 99. EXISTING ASPHALT DRIVEWAY
 100. EXISTING ASPHALT DRIVEWAY
 101. EXISTING ASPHALT DRIVEWAY
 102. EXISTING ASPHALT DRIVEWAY
 103. EXISTING ASPHALT DRIVEWAY
 104. EXISTING ASPHALT DRIVEWAY
 105. EXISTING ASPHALT DRIVEWAY
 106. EXISTING ASPHALT DRIVEWAY
 107. EXISTING ASPHALT DRIVEWAY
 108. EXISTING ASPHALT DRIVEWAY
 109. EXISTING ASPHALT DRIVEWAY
 110. EXISTING ASPHALT DRIVEWAY
 111. EXISTING ASPHALT DRIVEWAY
 112. EXISTING ASPHALT DRIVEWAY
 113. EXISTING ASPHALT DRIVEWAY
 114. EXISTING ASPHALT DRIVEWAY
 115. EXISTING ASPHALT DRIVEWAY
 116. EXISTING ASPHALT DRIVEWAY
 117. EXISTING ASPHALT DRIVEWAY
 118. EXISTING ASPHALT DRIVEWAY
 119. EXISTING ASPHALT DRIVEWAY
 120. EXISTING ASPHALT DRIVEWAY
 121. EXISTING ASPHALT DRIVEWAY
 122. EXISTING ASPHALT DRIVEWAY
 123. EXISTING ASPHALT DRIVEWAY
 124. EXISTING ASPHALT DRIVEWAY
 125. EXISTING ASPHALT DRIVEWAY
 126. EXISTING ASPHALT DRIVEWAY
 127. EXISTING ASPHALT DRIVEWAY
 128. EXISTING ASPHALT DRIVEWAY
 129. EXISTING ASPHALT DRIVEWAY
 130. EXISTING ASPHALT DRIVEWAY
 131. EXISTING ASPHALT DRIVEWAY
 132. EXISTING ASPHALT DRIVEWAY
 133. EXISTING ASPHALT DRIVEWAY
 134. EXISTING ASPHALT DRIVEWAY
 135. EXISTING ASPHALT DRIVEWAY
 136. EXISTING ASPHALT DRIVEWAY
 137. EXISTING ASPHALT DRIVEWAY
 138. EXISTING ASPHALT DRIVEWAY
 139. EXISTING ASPHALT DRIVEWAY
 140. EXISTING ASPHALT DRIVEWAY
 141. EXISTING ASPHALT DRIVEWAY
 142. EXISTING ASPHALT DRIVEWAY
 143. EXISTING ASPHALT DRIVEWAY
 144. EXISTING ASPHALT DRIVEWAY
 145. EXISTING ASPHALT DRIVEWAY
 146. EXISTING ASPHALT DRIVEWAY
 147. EXISTING ASPHALT DRIVEWAY
 148. EXISTING ASPHALT DRIVEWAY
 149. EXISTING ASPHALT DRIVEWAY
 150. EXISTING ASPHALT DRIVEWAY
 151. EXISTING ASPHALT DRIVEWAY
 152. EXISTING ASPHALT DRIVEWAY
 153. EXISTING ASPHALT DRIVEWAY
 154. EXISTING ASPHALT DRIVEWAY
 155. EXISTING ASPHALT DRIVEWAY
 156. EXISTING ASPHALT DRIVEWAY
 157. EXISTING ASPHALT DRIVEWAY
 158. EXISTING ASPHALT DRIVEWAY
 159. EXISTING ASPHALT DRIVEWAY
 160. EXISTING ASPHALT DRIVEWAY
 161. EXISTING ASPHALT DRIVEWAY
 162. EXISTING ASPHALT DRIVEWAY
 163. EXISTING ASPHALT DRIVEWAY
 164. EXISTING ASPHALT DRIVEWAY
 165. EXISTING ASPHALT DRIVEWAY
 166. EXISTING ASPHALT DRIVEWAY
 167. EXISTING ASPHALT DRIVEWAY
 168. EXISTING ASPHALT DRIVEWAY
 169. EXISTING ASPHALT DRIVEWAY
 170. EXISTING ASPHALT DRIVEWAY
 171. EXISTING ASPHALT DRIVEWAY
 172. EXISTING ASPHALT DRIVEWAY
 173. EXISTING ASPHALT DRIVEWAY
 174. EXISTING ASPHALT DRIVEWAY
 175. EXISTING ASPHALT DRIVEWAY
 176. EXISTING ASPHALT DRIVEWAY
 177. EXISTING ASPHALT DRIVEWAY
 178. EXISTING ASPHALT DRIVEWAY
 179. EXISTING ASPHALT DRIVEWAY
 180. EXISTING ASPHALT DRIVEWAY
 181. EXISTING ASPHALT DRIVEWAY
 182. EXISTING ASPHALT DRIVEWAY
 183. EXISTING ASPHALT DRIVEWAY
 184. EXISTING ASPHALT DRIVEWAY
 185. EXISTING ASPHALT DRIVEWAY
 186. EXISTING ASPHALT DRIVEWAY
 187. EXISTING ASPHALT DRIVEWAY
 188. EXISTING ASPHALT DRIVEWAY
 189. EXISTING ASPHALT DRIVEWAY
 190. EXISTING ASPHALT DRIVEWAY
 191. EXISTING ASPHALT DRIVEWAY
 192. EXISTING ASPHALT DRIVEWAY
 193. EXISTING ASPHALT DRIVEWAY
 194. EXISTING ASPHALT DRIVEWAY
 195. EXISTING ASPHALT DRIVEWAY
 196. EXISTING ASPHALT DRIVEWAY
 197. EXISTING ASPHALT DRIVEWAY
 198. EXISTING ASPHALT DRIVEWAY
 199. EXISTING ASPHALT DRIVEWAY
 200. EXISTING ASPHALT DRIVEWAY
 201. EXISTING ASPHALT DRIVEWAY
 202. EXISTING ASPHALT DRIVEWAY
 203. EXISTING ASPHALT DRIVEWAY
 204. EXISTING ASPHALT DRIVEWAY
 205. EXISTING ASPHALT DRIVEWAY
 206. EXISTING ASPHALT DRIVEWAY
 207. EXISTING ASPHALT DRIVEWAY
 208. EXISTING ASPHALT DRIVEWAY
 209. EXISTING ASPHALT DRIVEWAY
 210. EXISTING ASPHALT DRIVEWAY
 211. EXISTING ASPHALT DRIVEWAY
 212. EXISTING ASPHALT DRIVEWAY
 213. EXISTING ASPHALT DRIVEWAY
 214. EXISTING ASPHALT DRIVEWAY
 215. EXISTING ASPHALT DRIVEWAY
 216. EXISTING ASPHALT DRIVEWAY
 217. EXISTING ASPHALT DRIVEWAY
 218. EXISTING ASPHALT DRIVEWAY
 219. EXISTING ASPHALT DRIVEWAY
 220. EXISTING ASPHALT DRIVEWAY
 221. EXISTING ASPHALT DRIVEWAY
 222. EXISTING ASPHALT DRIVEWAY
 223. EXISTING ASPHALT DRIVEWAY
 224. EXISTING ASPHALT DRIVEWAY
 225. EXISTING ASPHALT DRIVEWAY
 226. EXISTING ASPHALT DRIVEWAY
 227. EXISTING ASPHALT DRIVEWAY
 228. EXISTING ASPHALT DRIVEWAY
 229. EXISTING ASPHALT DRIVEWAY
 230. EXISTING ASPHALT DRIVEWAY
 231. EXISTING ASPHALT DRIVEWAY
 232. EXISTING ASPHALT DRIVEWAY
 233. EXISTING ASPHALT DRIVEWAY
 234. EXISTING ASPHALT DRIVEWAY
 235. EXISTING ASPHALT DRIVEWAY
 236. EXISTING ASPHALT DRIVEWAY
 237. EXISTING ASPHALT DRIVEWAY
 238. EXISTING ASPHALT DRIVEWAY
 239. EXISTING ASPHALT DRIVEWAY
 240. EXISTING ASPHALT DRIVEWAY
 241. EXISTING ASPHALT DRIVEWAY
 242. EXISTING ASPHALT DRIVEWAY
 243. EXISTING ASPHALT DRIVEWAY
 244. EXISTING ASPHALT DRIVEWAY
 245. EXISTING ASPHALT DRIVEWAY
 246. EXISTING ASPHALT DRIVEWAY
 247. EXISTING ASPHALT DRIVEWAY
 248. EXISTING ASPHALT DRIVEWAY
 249. EXISTING ASPHALT DRIVEWAY
 250. EXISTING ASPHALT DRIVEWAY
 251. EXISTING ASPHALT DRIVEWAY
 252. EXISTING ASPHALT DRIVEWAY
 253. EXISTING ASPHALT DRIVEWAY
 254. EXISTING ASPHALT DRIVEWAY
 255. EXISTING ASPHALT DRIVEWAY
 256. EXISTING ASPHALT DRIVEWAY
 257. EXISTING ASPHALT DRIVEWAY
 258. EXISTING ASPHALT DRIVEWAY
 259. EXISTING ASPHALT DRIVEWAY
 260. EXISTING ASPHALT DRIVEWAY
 261. EXISTING ASPHALT DRIVEWAY
 262. EXISTING ASPHALT DRIVEWAY
 263. EXISTING ASPHALT DRIVEWAY
 264. EXISTING ASPHALT DRIVEWAY
 265. EXISTING ASPHALT DRIVEWAY
 266. EXISTING ASPHALT DRIVEWAY
 267. EXISTING ASPHALT DRIVEWAY
 268. EXISTING ASPHALT DRIVEWAY
 269. EXISTING ASPHALT DRIVEWAY
 270. EXISTING ASPHALT DRIVEWAY
 271. EXISTING ASPHALT DRIVEWAY
 272. EXISTING ASPHALT DRIVEWAY
 273. EXISTING ASPHALT DRIVEWAY
 274. EXISTING ASPHALT DRIVEWAY
 275. EXISTING ASPHALT DRIVEWAY
 276. EXISTING ASPHALT DRIVEWAY
 277. EXISTING ASPHALT DRIVEWAY
 278. EXISTING ASPHALT DRIVEWAY
 279. EXISTING ASPHALT DRIVEWAY
 280. EXISTING ASPHALT DRIVEWAY
 281. EXISTING ASPHALT DRIVEWAY
 282. EXISTING ASPHALT DRIVEWAY
 283. EXISTING ASPHALT DRIVEWAY
 284. EXISTING ASPHALT DRIVEWAY
 285. EXISTING ASPHALT DRIVEWAY
 286. EXISTING ASPHALT DRIVEWAY
 287. EXISTING ASPHALT DRIVEWAY
 288. EXISTING ASPHALT DRIVEWAY
 289. EXISTING ASPHALT DRIVEWAY
 290. EXISTING ASPHALT DRIVEWAY
 291. EXISTING ASPHALT DRIVEWAY
 292. EXISTING ASPHALT DRIVEWAY
 293. EXISTING ASPHALT DRIVEWAY
 294. EXISTING ASPHALT DRIVEWAY
 295. EXISTING ASPHALT DRIVEWAY
 296. EXISTING ASPHALT DRIVEWAY
 297. EXISTING ASPHALT DRIVEWAY
 298. EXISTING ASPHALT DRIVEWAY
 299. EXISTING ASPHALT DRIVEWAY
 300. EXISTING ASPHALT DRIVEWAY

ELEVATION NOTE:
 ALL ELEVATIONS ARE IN METERS AND REFER TO THE MEAN SEA LEVEL DATUM.
 ALL ELEVATIONS ARE TO THE TOP OF FINISHED SURFACE UNLESS OTHERWISE NOTED.
 ALL ELEVATIONS ARE TO BE TAKEN AS APPROXIMATE AND DO NOT CONSTITUTE A WARRANTY OF ACCURACY.

SURVEYOR'S CERTIFICATE

1. I, J.D. BARNES, A PROFESSIONAL ENGINEER IN LAND SURVEYING, HAVE SURVEYED THE ABOVE SHOWN PROPERTY AND HAVE PREPARED THIS PLAN IN ACCORDANCE WITH THE SURVEY ACT AND THE REGULATIONS MADE UNDER THEREIN.

2. THE SURVEY WAS COMPLETED ON JANUARY 20, 2020.

J.D. BARNES LIMITED
 1110 KENNEDY ROAD, OTTAWA, ONTARIO K1M 1Y7
 TEL: 453-3813 FAX: 453-3814
 JDBARNES@JDBARNES.COM

SHAWN LEVISON
 1110 KENNEDY ROAD, OTTAWA, ONTARIO K1M 1Y7
 TEL: 453-3813 FAX: 453-3814
 SLEVISON@JDBARNES.COM

REGISTERED PLAN M-44 (STREET FRONT ENTRANCE) NO. 113
 PIN 04236-0200(L/T)

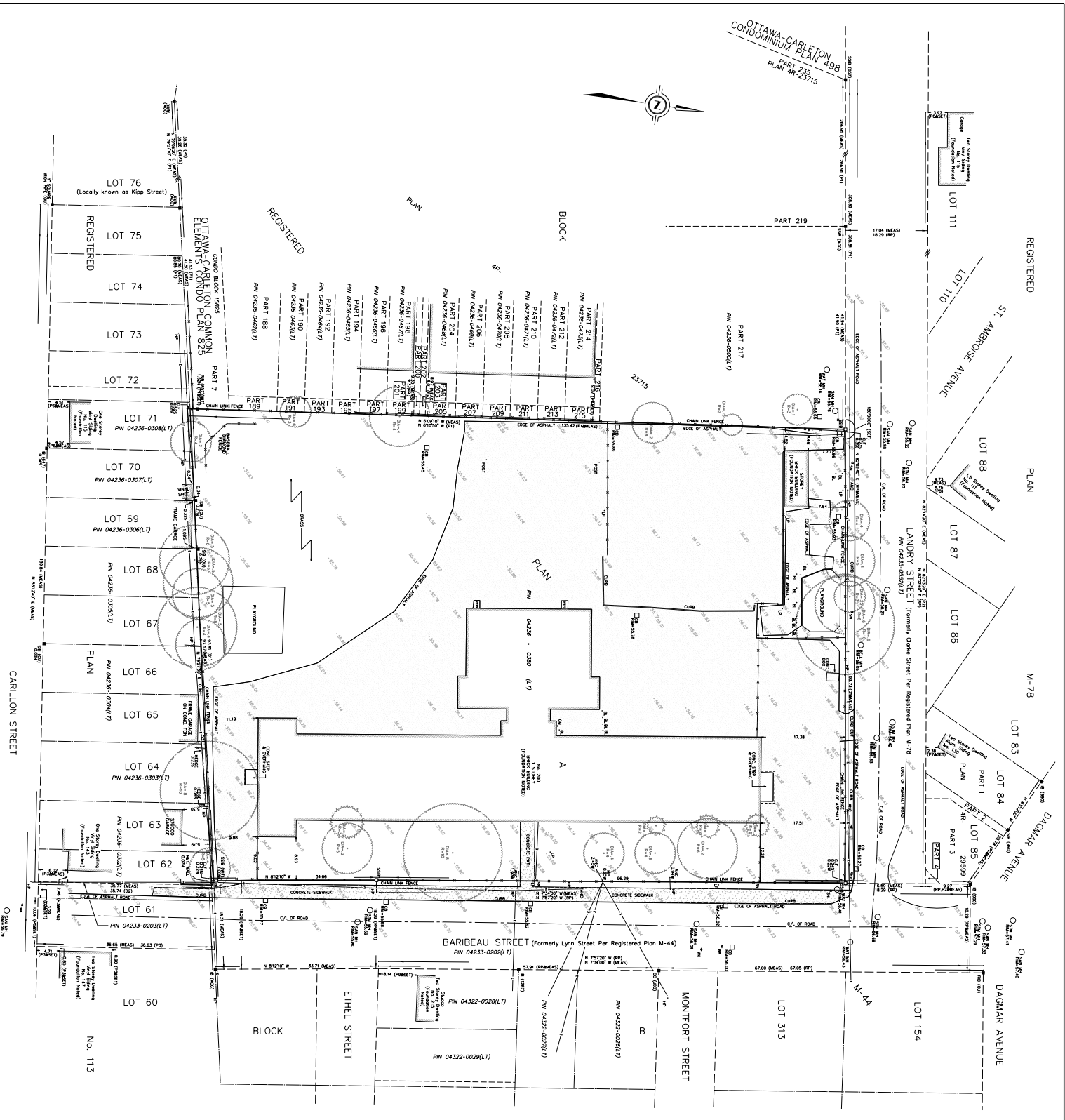

**APPENDIX B – SITE PLAN AND ARCHITECTURAL
PACKAGE**

SITE DATA

SITE STATISTICS (NUMBER OF UNITS & GROSS BUILDING AREA)

Block 1	4 UNITS	2200m ²
Block 2	4 UNITS	2200m ²
Block 3	4 UNITS	2200m ²
Block 4	4 UNITS	2200m ²
Block 5	4 UNITS	2200m ²
Block 6	4 UNITS	2200m ²
Block 7	4 UNITS	2200m ²
Block 8	4 UNITS	2200m ²
Block 9	4 UNITS	2200m ²
Block 10	4 UNITS	2200m ²
Block 11	4 UNITS	2200m ²
Block 12	4 UNITS	2200m ²
Block 13	4 UNITS	2200m ²
Block 14	4 UNITS	2200m ²
Block 15	4 UNITS	2200m ²
Block 16	4 UNITS	2200m ²
Block 17	4 UNITS	2200m ²
Block 18	4 UNITS	2200m ²
Block 19	4 UNITS	2200m ²
Block 20	4 UNITS	2200m ²
Block 21	4 UNITS	2200m ²
Block 22	4 UNITS	2200m ²
Block 23	4 UNITS	2200m ²
Block 24	4 UNITS	2200m ²
Block 25	4 UNITS	2200m ²
Block 26	4 UNITS	2200m ²
Block 27	4 UNITS	2200m ²
Block 28	4 UNITS	2200m ²
Block 29	4 UNITS	2200m ²
Block 30	4 UNITS	2200m ²
Block 31	4 UNITS	2200m ²
Block 32	4 UNITS	2200m ²
Block 33	4 UNITS	2200m ²
Block 34	4 UNITS	2200m ²
Block 35	4 UNITS	2200m ²
Block 36	4 UNITS	2200m ²
Block 37	4 UNITS	2200m ²
Block 38	4 UNITS	2200m ²
Block 39	4 UNITS	2200m ²
Block 40	4 UNITS	2200m ²
Block 41	4 UNITS	2200m ²
Block 42	4 UNITS	2200m ²
Block 43	4 UNITS	2200m ²
Block 44	4 UNITS	2200m ²
Block 45	4 UNITS	2200m ²
Block 46	4 UNITS	2200m ²
Block 47	4 UNITS	2200m ²
Block 48	4 UNITS	2200m ²
Block 49	4 UNITS	2200m ²
Block 50	4 UNITS	2200m ²
Block 51	4 UNITS	2200m ²
Block 52	4 UNITS	2200m ²
Block 53	4 UNITS	2200m ²
Block 54	4 UNITS	2200m ²
Block 55	4 UNITS	2200m ²
Block 56	4 UNITS	2200m ²
Block 57	4 UNITS	2200m ²
Block 58	4 UNITS	2200m ²
Block 59	4 UNITS	2200m ²
Block 60	4 UNITS	2200m ²
Block 61	4 UNITS	2200m ²
Block 62	4 UNITS	2200m ²
Block 63	4 UNITS	2200m ²
Block 64	4 UNITS	2200m ²
Block 65	4 UNITS	2200m ²
Block 66	4 UNITS	2200m ²
Block 67	4 UNITS	2200m ²
Block 68	4 UNITS	2200m ²
Block 69	4 UNITS	2200m ²
Block 70	4 UNITS	2200m ²
Block 71	4 UNITS	2200m ²
Block 72	4 UNITS	2200m ²
Block 73	4 UNITS	2200m ²
Block 74	4 UNITS	2200m ²
Block 75	4 UNITS	2200m ²
Block 76	4 UNITS	2200m ²
Block 77	4 UNITS	2200m ²
Block 78	4 UNITS	2200m ²
Block 79	4 UNITS	2200m ²
Block 80	4 UNITS	2200m ²
Block 81	4 UNITS	2200m ²
Block 82	4 UNITS	2200m ²
Block 83	4 UNITS	2200m ²
Block 84	4 UNITS	2200m ²
Block 85	4 UNITS	2200m ²
Block 86	4 UNITS	2200m ²
Block 87	4 UNITS	2200m ²
Block 88	4 UNITS	2200m ²
Block 89	4 UNITS	2200m ²
Block 90	4 UNITS	2200m ²
Block 91	4 UNITS	2200m ²
Block 92	4 UNITS	2200m ²
Block 93	4 UNITS	2200m ²
Block 94	4 UNITS	2200m ²
Block 95	4 UNITS	2200m ²
Block 96	4 UNITS	2200m ²
Block 97	4 UNITS	2200m ²
Block 98	4 UNITS	2200m ²
Block 99	4 UNITS	2200m ²
Block 100	4 UNITS	2200m ²

PLANNED UNIT DEVELOPMENT ZONING MECHANISM

LOADING TYPE	REQD - 90 UNITS	PROPOSED
MIN. WIDTH OF PRIVATE DRIVEWAY	6.0m	6.0m
MIN. SEPARATION AREA BETWEEN BUILDINGS	1.2m MIN.	1.62m MIN.

SETBACKS

MIN. LOT WIDTH: 15.24m
MIN. BUILDING HEIGHT: 15.24m

PARKING REQUIREMENTS - RESIDENTS
(PARKING PROVISIONS 2008-2009 SECTION 100)

REQUIREMENTS	REQUIREMENTS
MIN. SEPARATION AREA BETWEEN BUILDINGS	1.2m MIN.
MIN. LOT WIDTH	15.24m
MIN. BUILDING HEIGHT	15.24m

CONTRACTORS
ARCHITECT: PARKRIVER ARCHITECTURE INC.
60 PARKWAY STREET, SUITE 100, WILLOWDALE, ONTARIO, CANADA M2H 3K7
CONTACT: (416) 491-2200
FAX: (416) 491-2005

APPROVAL SIGNATURE [Signature] DATE: [Date]

GRAPHIC SCALE 1:250
0m 5m 10m 15m 20m

LOCATION MAP [Map showing site location in Toronto]

SURVEY INFORMATION

REAL PROPERTY REPORT
PART OF BLOCK A
REGISTERED PLAN M-44
CITY OF OTTAWA

DATE: 13/04/2011
TOTAL GROSS BUILDING AREA: 15,240m²
TOTAL LOT SURFACE AREA: 15,240m²
TOTAL LOT COVERAGE: 100%
TOTAL LOT AREA: 15,240m²
TOTAL LOT PERCENTAGE: 100%

ENCL. AREA: 2000

PLANNED UNIT DEVELOPMENT ZONING MECHANISM

LOADING TYPE: REQD - 90 UNITS, PROPOSED

MIN. WIDTH OF PRIVATE DRIVEWAY: 6.0m, 6.0m

MIN. SEPARATION AREA BETWEEN BUILDINGS: 1.2m MIN., 1.62m MIN.

SETBACKS

MIN. LOT WIDTH: 15.24m, 15.24m
MIN. BUILDING HEIGHT: 15.24m, 15.24m

PARKING REQUIREMENTS - RESIDENTS
(PARKING PROVISIONS 2008-2009 SECTION 100)

REQUIREMENTS: 1.2m MIN. SEPARATION AREA BETWEEN BUILDINGS, 1.2m MIN. SEPARATION AREA BETWEEN BUILDINGS, 1.2m MIN. SEPARATION AREA BETWEEN BUILDINGS

CONTRACTORS: ARCHITECT: PARKRIVER ARCHITECTURE INC., 60 PARKWAY STREET, SUITE 100, WILLOWDALE, ONTARIO, CANADA M2H 3K7, CONTACT: (416) 491-2200, FAX: (416) 491-2005

APPROVAL SIGNATURE: [Signature], DATE: [Date]

GRAPHIC SCALE: 1:250, 0m 5m 10m 15m 20m

LOCATION MAP: [Map showing site location in Toronto]

LANDRY STREET (Formerly Clarke Street) Per Registered Plan M-78 PIN 04235-0532(LT)

BARBEAU STREET (Formerly Lynn Street) Per Registered Plan M-44 PIN 04235-0202(LT)

50769 PARK

0.09Ha park

Front Elevation Block 10-12 (Unit A-B)



FINISH MATERIAL LEGEND:

BV-1	BRICK VENEER - COLOUR 1
BV-2	BRICK VENEER - COLOUR 2
HBP	JAMES HARDIE (SMOOTH FINISH)
M-FL	PRE-FIN. METAL FLASHING
MS-1	METAL SIDING - DARK COLOUR 1
MS-2	METAL SIDING - LIGHT COLOUR 2
MV-1	MASONRY VENEER - COLOUR 1
VS	WOOD LOUVERS
WS	HORIZONTAL WOOD SIDING



ELEVATIONS

200 BARIBEAU STREET TOWNS

SCALE = 1:100
JULY 15th, 2020

Side Elevation Block 10-12 (Unit A-B)



FINISH MATERIAL LEGEND:

BV-1	BRICK VENEER - COLOUR 1
BV-2	BRICK VENEER - COLOUR 2
HBP	JAMES HARDIE (SMOOTH FINISH)
M-FL	PRE-FIN. METAL FLASHING
MS-1	METAL SIDING - DARK COLOUR 1
MS-2	METAL SIDING - LIGHT COLOUR 2
MV-1	MASONRY VENEER - COLOUR 1
VS	WOOD LOUVERS
WS	HORIZONTAL WOOD SIDING



Front Elevation Block 9 (Unit C-D)

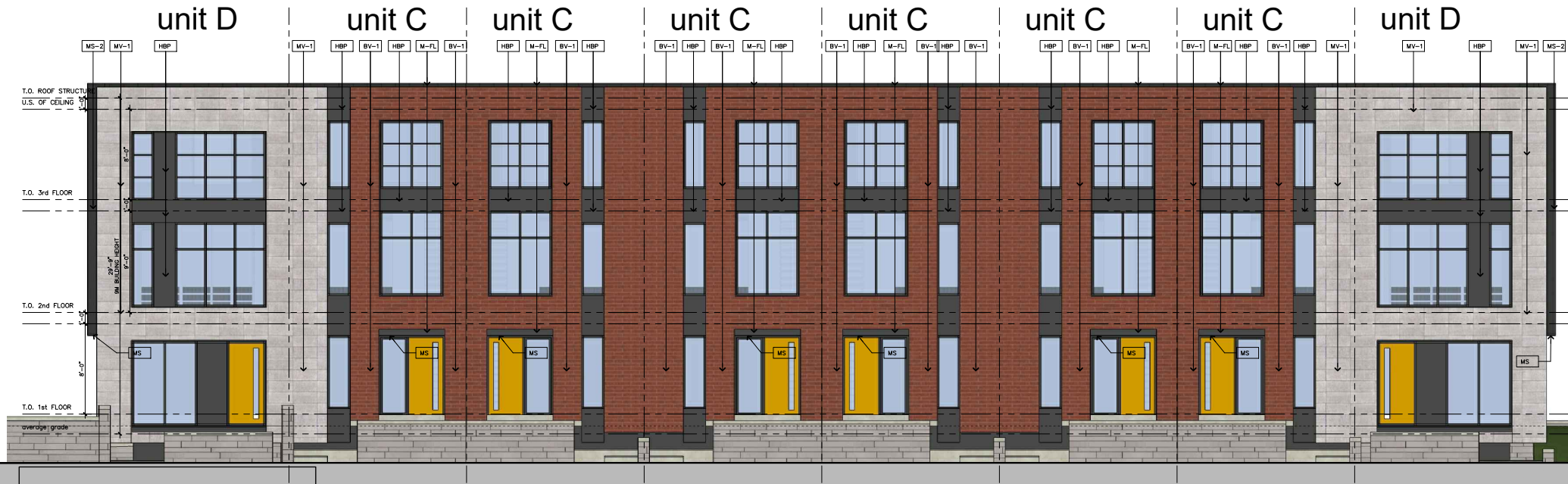

FINISH MATERIAL LEGEND:

BV-1	BRICK VENEER - COLOUR 1
BV-2	BRICK VENEER - COLOUR 2
HBP	JAMES HARDIE (SMOOTH FINISH)
M-FL	PRE-FIN. METAL FLASHING
MS-1	METAL SIDING - DARK COLOUR 1
MS-2	METAL SIDING - LIGHT COLOUR 2
MV-1	MASONRY VENEER - COLOUR 1
VS	WOOD LOUVERS
WS	HORIZONTAL WOOD SIDING



ELEVATIONS

200 BARIBEAU STREET TOWNS

SCALE = 1:100
JULY 15th, 2020

Rear Elevation Block 9 (Unit C-D)

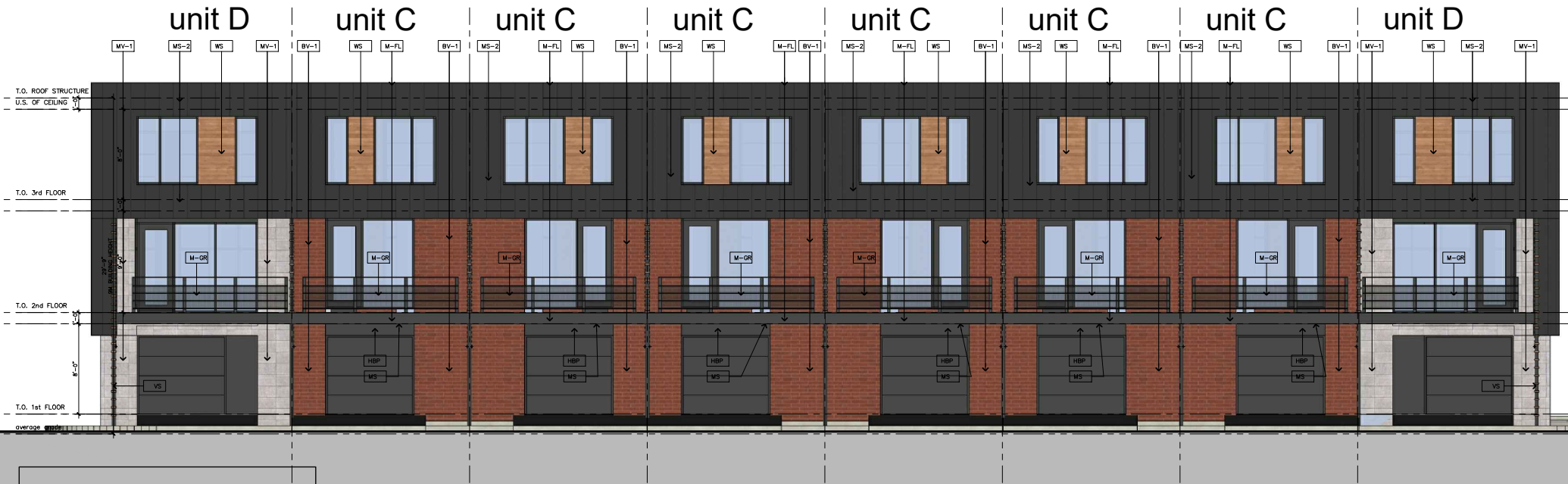

FINISH MATERIAL LEGEND:

BV-1	BRICK VENEER - COLOUR 1
BV-2	BRICK VENEER - COLOUR 2
HBP	JAMES HARDIE (SMOOTH FINISH)
M-FL	PRE-FIN. METAL FLASHING
MS-1	METAL SIDING - DARK COLOUR 1
MS-2	METAL SIDING - LIGHT COLOUR 2
MV-1	MASONRY VENEER - COLOUR 1
VS	WOOD LOUVERS
WS	HORIZONTAL WOOD SIDING



ELEVATIONS

200 BARIBEAU STREET TOWNS

SCALE = 1:100
JULY 15th, 2020

Side Elevation Block 9 (Unit C-D)



FINISH MATERIAL LEGEND:

BV-1	BRICK VENEER - COLOUR 1
BV-2	BRICK VENEER - COLOUR 2
HBP	JAMES HARDIE (SMOOTH FINISH)
M-FL	PRE-FIN. METAL FLASHING
MS-1	METAL SIDING - DARK COLOUR 1
MS-2	METAL SIDING - LIGHT COLOUR 2
MV-1	MASONRY VENEER - COLOUR 1
VS	WOOD LOUVERS
WS	HORIZONTAL WOOD SIDING



ELEVATIONS

200 BARIBEAU STREET TOWNS

SCALE = 1:100
JULY 15th, 2020

Front Elevation Block 1-4 (Unit E-F)



Rear Elevation Block 1-4 (Unit E-F)

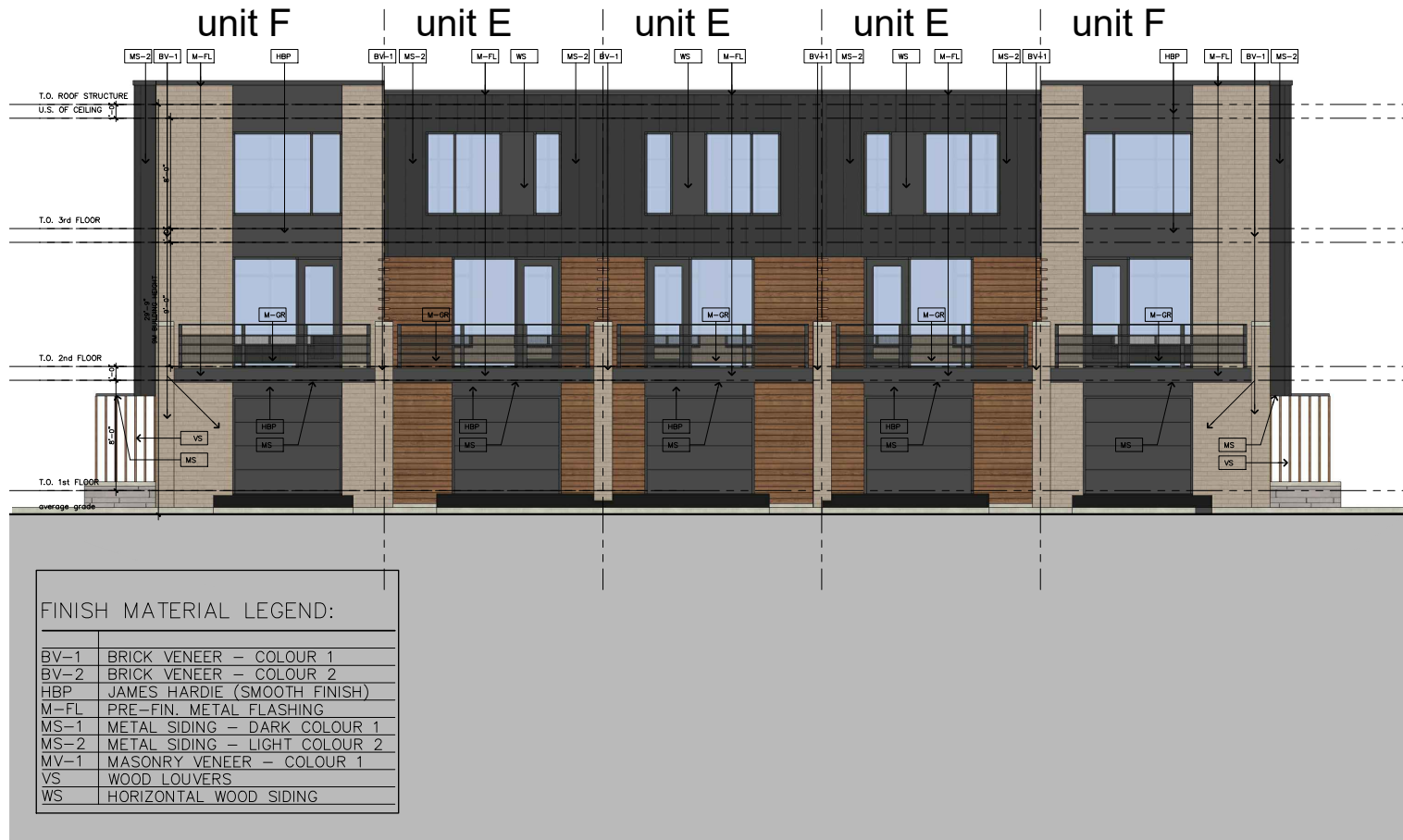

Side Elevation Block 1-4 (Unit E-F)

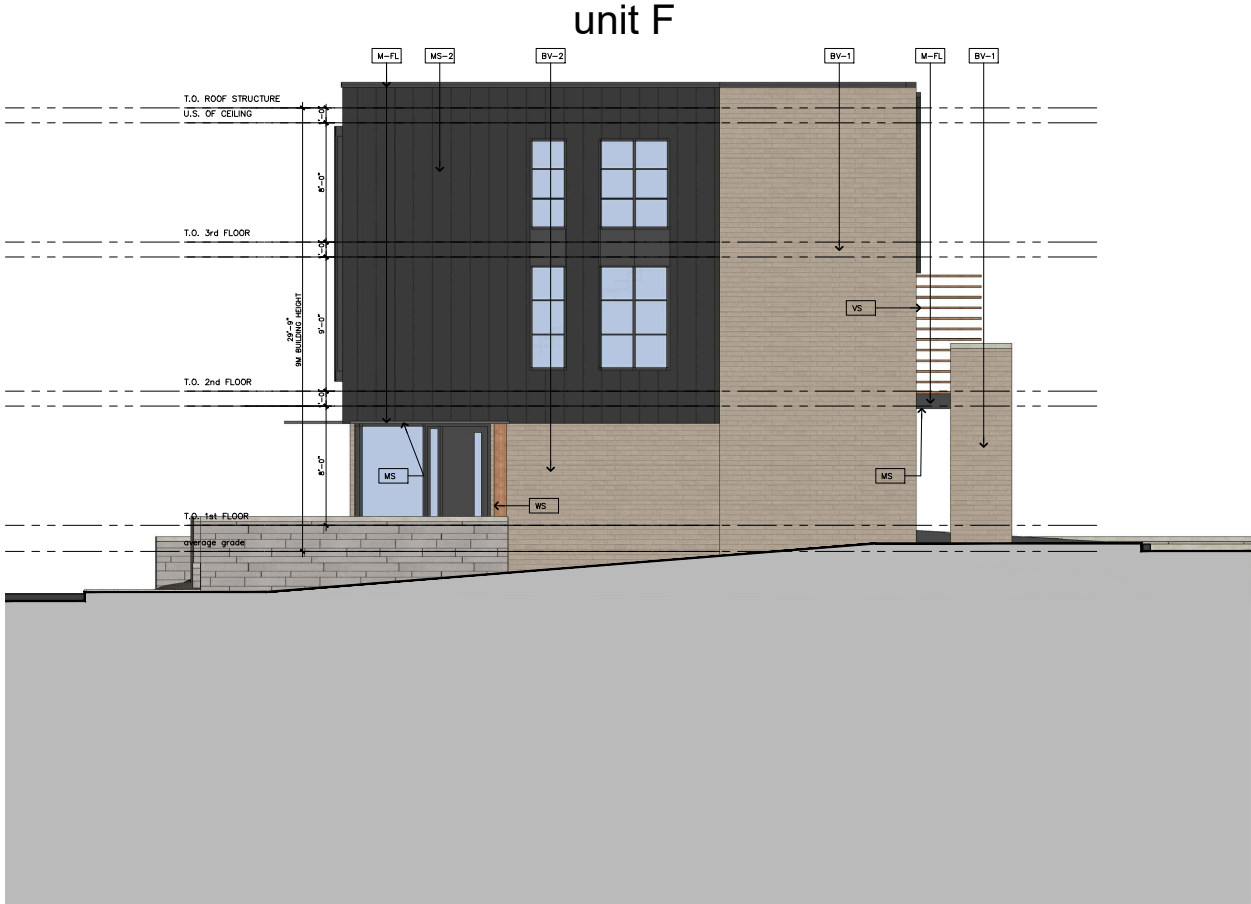

Front Elevation Block 5-7 (Unit G-H)



FINISH MATERIAL LEGEND:

BV-1	BRICK VENEER - COLOUR 1
BV-2	BRICK VENEER - COLOUR 2
HBP	JAMES HARDIE (SMOOTH FINISH)
M-FL	PRE-FIN. METAL FLASHING
MS-1	METAL SIDING - DARK COLOUR 1
MS-2	METAL SIDING - LIGHT COLOUR 2
MV-1	MASONRY VENEER - COLOUR 1
VS	WOOD LOUVERS
WS	HORIZONTAL WOOD SIDING



ELEVATIONS

200 BARIBEAU STREET TOWNS

SCALE = 1:100
JULY 15th, 2020

Rear Elevation Block 5-7 (Unit G-H)



FINISH MATERIAL LEGEND:

BV-1	BRICK VENEER - COLOUR 1
BV-2	BRICK VENEER - COLOUR 2
HBP	JAMES HARDIE (SMOOTH FINISH)
M-FL	PRE-FIN. METAL FLASHING
MS-1	METAL SIDING - DARK COLOUR 1
MS-2	METAL SIDING - LIGHT COLOUR 2
MV-1	MASONRY VENEER - COLOUR 1
VS	WOOD LOUVERS
WS	HORIZONTAL WOOD SIDING



ELEVATIONS

200 BARIBEAU STREET TOWNS

SCALE = 1:100
JULY 15th, 2020

Side Elevation Block 5-7 (Unit G-H)



FINISH MATERIAL LEGEND:

BV-1	BRICK VENEER - COLOUR 1
BV-2	BRICK VENEER - COLOUR 2
HBP	JAMES HARDIE (SMOOTH FINISH)
M-FL	PRE-FIN. METAL FLASHING
MS-1	METAL SIDING - DARK COLOUR 1
MS-2	METAL SIDING - LIGHT COLOUR 2
MV-1	MASONRY VENEER - COLOUR 1
VS	WOOD LOUVERS
WS	HORIZONTAL WOOD SIDING



ELEVATIONS

200 BARIBEAU STREET TOWNS

SCALE = 1:100
JULY 15th, 2020

AERIAL VIEW LOOKING SOUTH



RENDERINGS

200 BARIBEAU STREET TOWNS

JULY 15th, 2020

BLOCKS A-B



RENDERINGS

200 BARIBEAU STREET TOWNS

JULY 15th, 2020

BLOCKS A-B



RENDERINGS

200 BARIBEAU STREET TOWNS

JULY 15th, 2020

BLOCKS C-D



RENDERINGS

200 BARIBEAU STREET TOWNS

JULY 15th, 2020

BLOCKS C-D - BARIBEAU STREET PARK



RENDERINGS

200 BARIBEAU STREET TOWNS

JULY 15th, 2020

BLOCKS E-F



RENDERINGS

200 BARIBEAU STREET TOWNS

JULY 15th, 2020

BLOCKS E-F STREET VIEW



RENDERINGS

200 BARIBEAU STREET TOWNS

JULY 15th, 2020

BLOCKS G-H



RENDERINGS

200 BARIBEAU STREET TOWNS

JULY 15th, 2020

BLOCKS G-H



RENDERINGS

200 BARIBEAU STREET TOWNS

JULY 15th, 2020

AERIAL VIEW LOOKING SOUTH



RENDERINGS

200 BARIBEAU STREET TOWNS

JULY 15th, 2020

HYDRO ROOM - AERIAL VIEW



200 BARIBEAU STREET TOWNS

JUNE 23RD, 2020

HYDRO ROOM - AERIAL VIEW - OPTION 2



200 BARIBEAU STREET TOWNS

HYDRO ROOM - OPTION 2



200 BARIBEAU STREET TOWNS

HYDRO ROOM - OPTION 2



200 BARIBEAU STREET TOWNS

APPENDIX C – LANDSCAPE PLAN

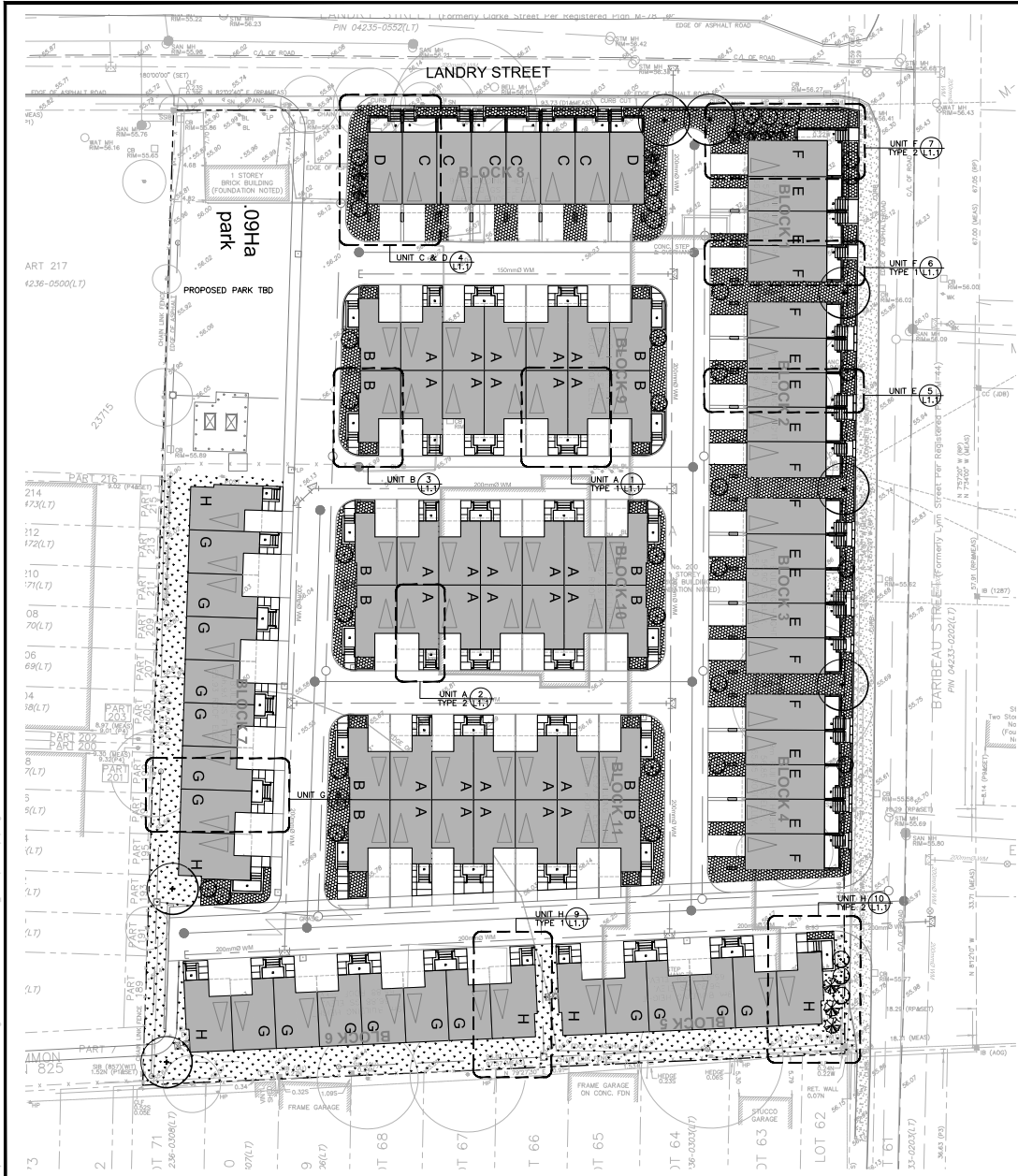

SYM.	BOTANICAL NAME	COMMON NAME	QTY.	SIZE	REMARKS
PLANT LIST					
LARGE DECIDUOUS TREES					
AF	ACER FREEMANI 'CELZAM'	CELEBRATION MAPLE	---	70mm CAL.	B&B / W.B.
SMALL DECIDUOUS TREES					
AP	ACER PLATANOIDES 'COLUMARE'	COLUMNAR NORWAY MAPLE	---	1800mm HT.	B&B / W.B.
QR	QUERCUS ROBUR 'FASTIGIATA'	COLUMNAR ENGLISH OAK	---	1800mm HT.	B&B / W.B.
RT	RHUS TYPHINA	STAGHORN SUMAC	---	600mm HT.	WHIP/BARKROOT, 1.2m O.C.
CONIFEROUS TREES					
AP	JUNPERIS SCOPULORUM 'SKYROCKET'	SKYROCKET JUNIPER	---	1800mm HT.	B&B / W.B.
SHRUBS					
JH	JUNPERIS HORIZONTALIS 'PLUMSA COMPACTA'	COMPACT ANDORA JUNIPER	---	600mm SPR.	POT. 750mm O.C.
SB	SPIREA X BUMALDA 'GOLDFLAME'	GOLDFLAME SPIREA	---	500mm HT.	POT. 600mm O.C.
SS	SORBARIA SORBIFOLIA	FALSE SPIREA	---	500mm HT.	POT. 900mm O.C.
RA	RHUS AROMATICA 'GRO-LOW'	GRO-LOW FRAGRANT SUMAC	---	1 GAL. POT.	POT. 600mm O.C.
PERENNIALS AND GRASSES					
HS	HEMEROCALLIS 'STELLA D'ORO'	STELL D'ORO DAYLILY	---	1 GAL. POT.	POT. 400mm O.C.
MS	MISCANTHUS SIN. 'GRACILLIMUS'	MAIDEN GRASS	---	1 GAL. POT.	POT. 600mm O.C.
PV	PANICUM VIRGATUM	SWITCH GRASS	---	1 GAL. POT.	POT. 600mm O.C.

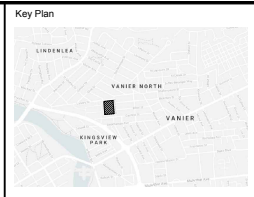

- LEGEND**
- PROPOSED LARGE DECIDUOUS TREES
 - PROPOSED SMALL DECIDUOUS TREES
 - PROPOSED CONIFEROUS TREES
 - SHRUB / PERENNIAL PLANTING
 - 100mm TOPSOIL AND 500 ON TOP OF FREE-DRAINING GROWING MEDIUM

No.	Revision	Date
4	RE-ISSUED FOR SPA	03 SEPT 2020
3	RE-ISSUED FOR SPA	10 AUG 2020
2	ISSUED FOR SPA	17 JULY 2020
1	ISSUED FOR COORDINATION	10 JULY 2020

North:

Stamp:

CSW Landscape Architecture
 Urban Design
 Site Planning
 Recreation and Park Planning
 Project Management

319 McRae Avenue, Suite 502, Ottawa, Ontario, K1Z 0B9
 Tel: (613) 729-4536

- All measurements in millimeters unless specified otherwise. Do not scale drawing. All drawings to be read in conjunction with written specifications.
- Copyright reserved. This drawing is the exclusive property of CSW Landscape Architects Ltd. and shall not be used without the consent thereof.
- This Drawing may not be used for construction until signed by the landscape architect. It is the responsibility of the contractor to:
 - check and verify all dimensions on site;
 - report all errors and/or omissions to the landscape architect;
 - comply with all pertinent codes and by-laws;
 - check and verify locations of all underground services with all local utilities prior to any digging.

Project:
 200 BARBEAU STREET
 RESIDENTIAL DEVELOPMENT

200 BARBEAU STREET
 OTTAWA, ONTARIO

Drawing:
 LANDSCAPE LAYOUT

Scale:	1:300	Date:	JULY 06 2020
Design By:	SMc	Drawn By:	SMc
Project Number:	2053-01	Sheet Number:	L 1.0

Scale: 1:300



Land Drawn: 03/03/2020 10:03:00 AM
 User: jsmith@csww.com
 Project: 200 Barbeau Street Residential Development (2053-01) 200 Barbeau Street
 Drawing: 03/03/2020 10:03:00 AM

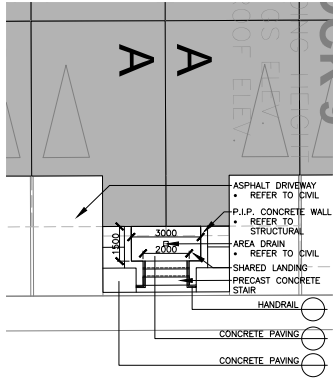

1 UNIT A - TYPE 1 Scale: 1:100

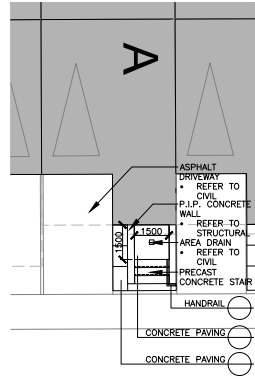

2 UNIT A - TYPE 2 Scale: 1:100

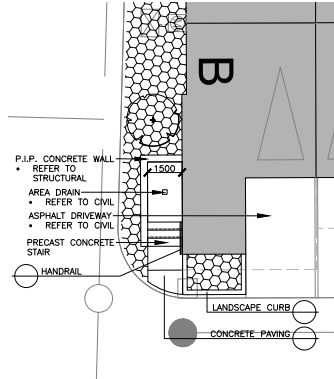

3 UNIT B Scale: 1:100

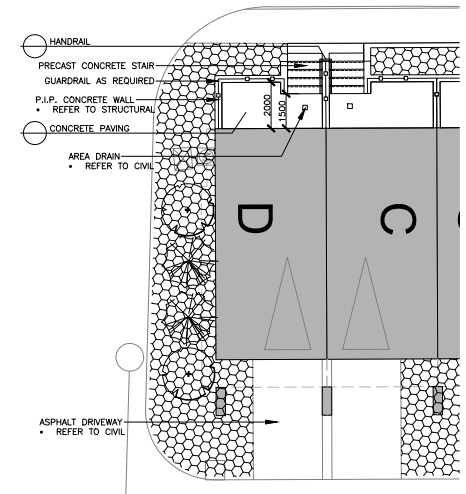

4 UNIT C & D Scale: 1:100

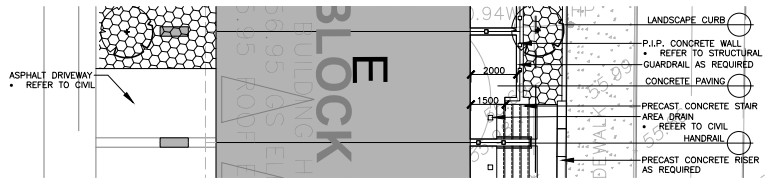

5 UNIT E Scale: 1:100

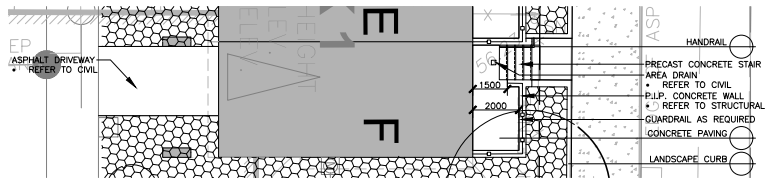

6 UNIT F - TYPE 1 Scale: 1:100

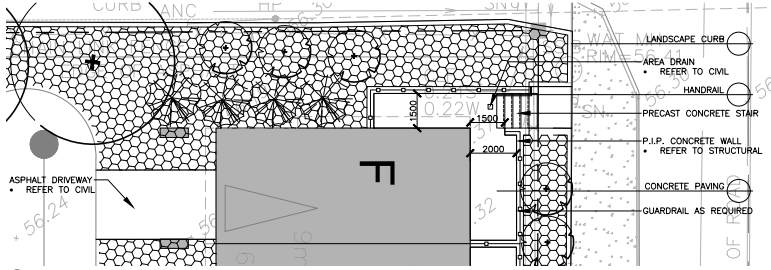

7 UNIT F - TYPE 2 Scale: 1:100

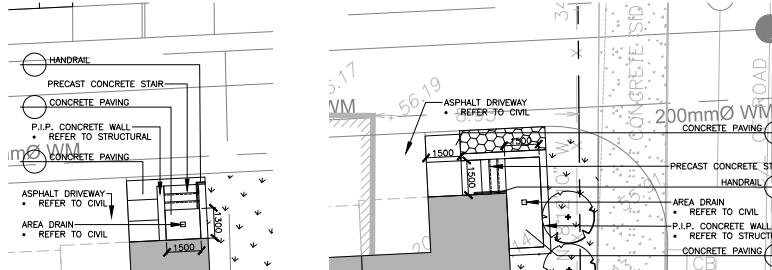

9 UNIT H - TYPE 1 Scale: 1:100

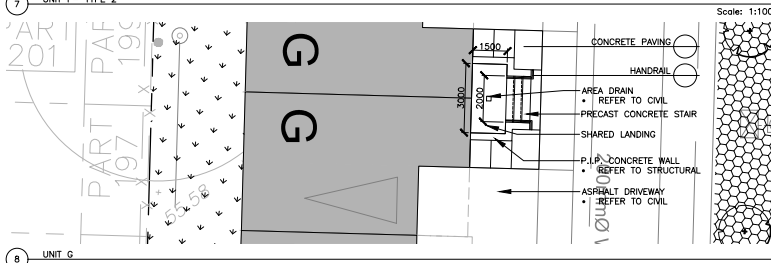

8 UNIT G Scale: 1:100

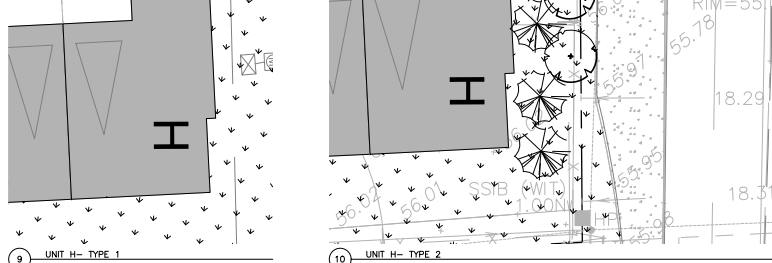

10 UNIT H - TYPE 2 Scale: 1:100

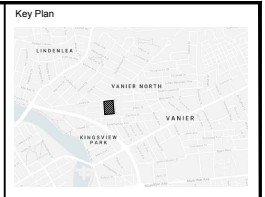

LEGEND

- PROPOSED LARGE DECIDUOUS TREES
- PROPOSED SMALL DECIDUOUS TREES
- PROPOSED CONIFEROUS TREES
- SHRUB / PERENNIAL PLANTING
- 100mm TOPSOIL AND 500 ON TOP OF FREE-DRAINING GROWING MEDIUM

No.	Revision	Date
4	RE-ISSUED FOR SPA	03 SEPT 2020
3	RE-ISSUED FOR SPA	10 AUG 2020
2	ISSUED FOR SPA	17 JULY 2020
1	ISSUED FOR COORDINATION	10 JULY 2020

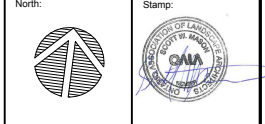

CSW Landscape Architecture
Urban Design
Site Planning
Recreation and Park Planning
Project Management

- 319 McRae Avenue, Suite 502, Ottawa, Ontario, K1Z 0B9
Tel: (613) 729-4536
- All measurements in millimeters unless specified otherwise. Do not scale drawing. All drawings to be read in conjunction with written specifications.
 - Copyright reserved. This drawing is the exclusive property of CSW Landscape Architects Ltd. and shall not be used without the consent thereof.
 - This Drawing may not be used for construction until signed by the landscape architect. It is the responsibility of the contractor to:
 - check and verify all dimensions on site;
 - report all errors and/or omissions to the landscape architect;
 - comply with all pertinent codes and by-laws;
 - check and verify locations of all underground services with all local utilities prior to any digging.

Project:
**200 BARIBEAU STREET
RESIDENTIAL DEVELOPMENT**

200 BARIBEAU STREET
OTTAWA, ONTARIO

Drawing:
LANDSCAPE LAYOUT

Scale: AS NOTED	Date: JULY 06 2020
Design By: SMC	Drawn By: SMC
Project Number: 2053-01	Sheet Number: L 1.1

CSW Landscape Architecture
 319 McRae Avenue, Suite 502, Ottawa, Ontario, K1Z 0B9
 Tel: (613) 729-4536
 www.csw.ca
 03/09/2020 10:03:00 AM

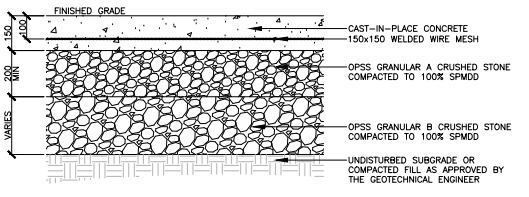

1 CONCRETE PAVING 1:10

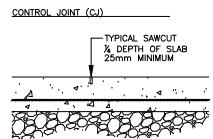

NOTES:
1. REFER TO DRAWINGS FOR JOINT LAYOUT
2. SAWCUT WITHIN 48 HOURS OF POUR
3. NO TOOLED EDGES

2 CONCRETE JOINTS 1:10

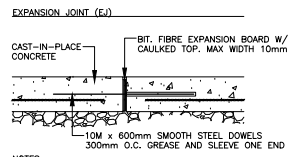

NOTES:
1. REFER TO DRAWINGS FOR JOINT LAYOUT
2. ALL STEEL DOWELS TO BE EPOXY COATED
3. NO TOOLED EDGES

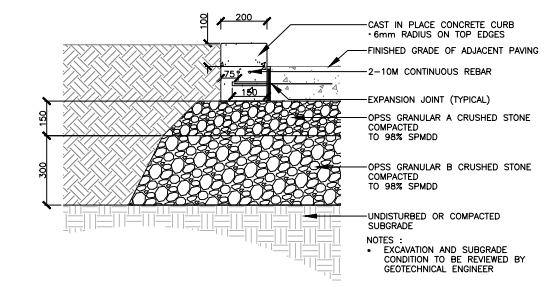

3 LANDSCAPE CURB 1:10

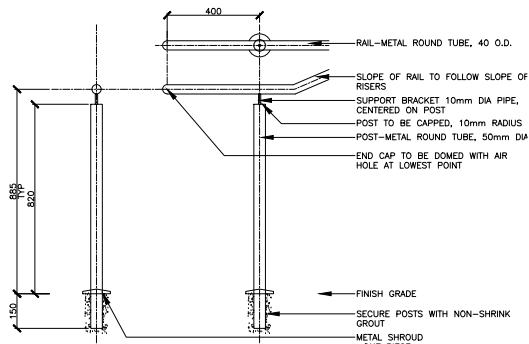

NOTES:
1. ALL METAL TO BE MARINE GRADE, SAE 316, STAINLESS STEEL
2. ALL WELDS TO BE FULL LENGTH AND BOTH SIDES OF ALL METAL SURFACES
3. GRIND SMOOTH ALL JOINTS AND EDGES
4. CONTRACTOR TO SUBMIT SHOP DRAWINGS FOR REVIEW PRIOR TO FABRICATION

6 HAND RAIL

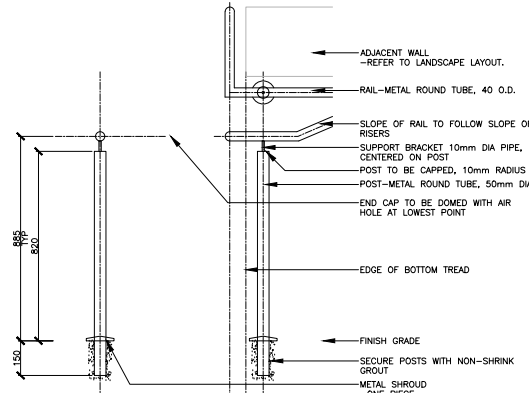

NOTES:
1. ALL METAL TO BE MARINE GRADE, SAE 316, STAINLESS STEEL
2. ALL WELDS TO BE FULL LENGTH AND BOTH SIDES OF ALL METAL SURFACES
3. GRIND SMOOTH ALL JOINTS AND EDGES
4. CONTRACTOR TO SUBMIT SHOP DRAWINGS FOR REVIEW PRIOR TO FABRICATION

90 DEGREE BEND (ONE-SIDED)

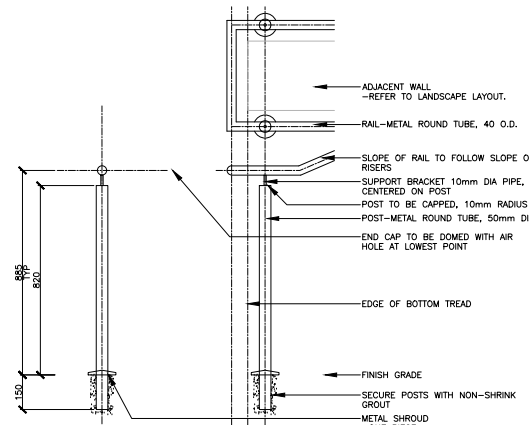

NOTES:
1. ALL METAL TO BE MARINE GRADE, SAE 316, STAINLESS STEEL
2. ALL WELDS TO BE FULL LENGTH AND BOTH SIDES OF ALL METAL SURFACES
3. GRIND SMOOTH ALL JOINTS AND EDGES
4. CONTRACTOR TO SUBMIT SHOP DRAWINGS FOR REVIEW PRIOR TO FABRICATION

90 DEGREE BEND (TWO-SIDED)

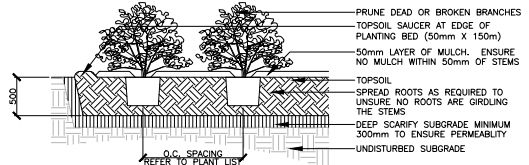

NOTES:
• TOP OF ROOT BALL TO RETAIN SAME ELEVATION AS GROWING CONDITIONS

7 SHRUB PLANTING 1:30

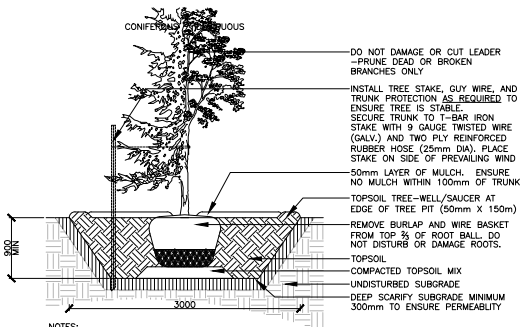

NOTES:
• TREE STAKES ARE GENERALLY ARE TO BE USED FOR CONDITIONS WHERE THE INSTALLED TREE IS UNSTABLE AND/OR BECOMES UNSTABLE
• ALLOW 10mm TO 25mm SLACK ON GUY WIRE SUPPORT FOR TREE
• TOP OF ROOT BALL TO RETAIN SAME ELEVATION AS GROWING CONDITIONS
• REMOVE STAKES ONE YEAR AFTER INSTALL
• INSTALL STAKE BEYOND EDGE OF ROOT BALL

8 TREE PLANTING 1:30

Key Plan

4	RE-ISSUED FOR SPA	03 SEPT 2020
3	RE-ISSUED FOR SPA	10 AUG 2020
2	ISSUED FOR SPA	17 JULY 2020
1	ISSUED FOR COORDINATION	10 JULY 2020
No.	Revision	Date

North: Stamp:

Landscape Architecture
Urban Design
Site Planning
Recreation and Park Planning
Project Management

CSW

319 McRae Avenue, Suite 502, Ottawa, Ontario, K1Z 0B9
Tel: (613) 729-4536

- All measurements in millimeters unless specified otherwise. Do not scale drawing. All drawings to be read in conjunction with written specifications.
- Copyright reserved. This drawing is the exclusive property of CSW Landscape Architects Ltd. and shall not be used without the consent thereof.
- This Drawing may not be used for construction until signed by the landscape architect. It is the responsibility of the contractor to:
 - check and verify all dimensions on site;
 - report all errors and/or omissions to the landscape architect;
 - comply with all pertinent codes and by-laws;
 - check and verify locations of all underground services with all local utilities prior to any digging.

Project:
**200 BARIBEAU STREET
RESIDENTIAL DEVELOPMENT**

200 BARIBEAU STREET
OTTAWA, ONTARIO

Drawing:
LANDSCAPE DETAILS

Scale: AS NOTED	Date: JULY 06 2020
Design By: SMC	Drawn By: SMC
Project Number: 2053-01	Sheet Number: L 2.0

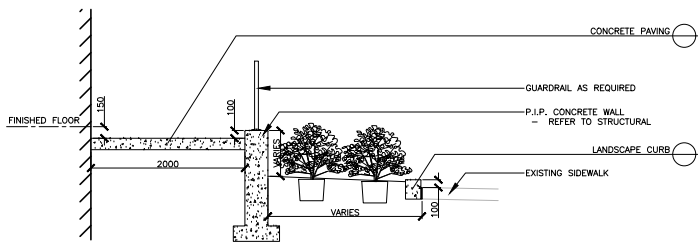

1 CROSS SECTION A - UNITS C, D, E & F 1:30

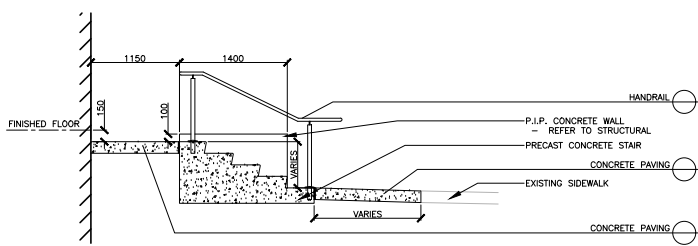

2 CROSS SECTION B - UNITS C, D, E & F 1:30

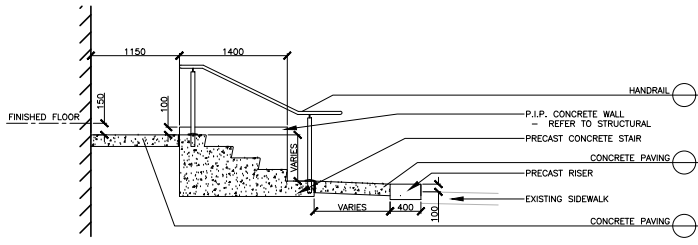

3 CROSS SECTION C - UNITS E, F 1:30

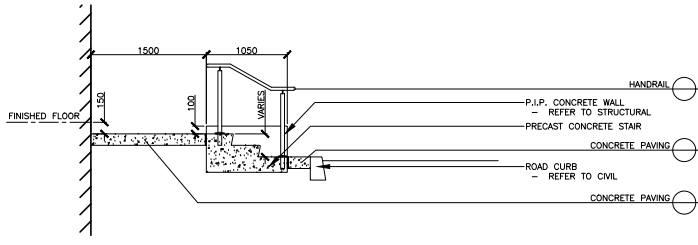

4 CROSS SECTION - UNITS A, G, H 1:30

Key Plan

No.	Revision	Date
4	RE-ISSUED FOR SPA	03 SEPT 2020
3	RE-ISSUED FOR SPA	10 AUG 2020
2	ISSUED FOR SPA	17 JULY 2020
1	ISSUED FOR COORDINATION	10 JULY 2020

North: Stamp:

CSW Landscape Architecture
 Urban Design
 Site Planning
 Recreation and Park Planning
 Project Management

319 McRae Avenue, Suite 502, Ottawa, Ontario, K1Z 0B9
 Tel: (613) 729-4536

- All measurements in millimeters unless specified otherwise. Do not scale drawing. All drawings to be read in conjunction with written specifications.
- Copyright reserved. This drawing is the exclusive property of CSW Landscape Architects Ltd. and shall not be used without the consent thereof.
- This Drawing may not be used for construction until signed by the landscape architect. It is the responsibility of the contractor to:
 - check and verify all dimensions on site;
 - report all errors and/or omissions to the landscape architect;
 - comply with all pertinent codes and by-laws;
 - check and verify locations of all underground services with all local utilities prior to any digging.

Project:
**200 BARIBEAU STREET
 RESIDENTIAL DEVELOPMENT**

200 BARIBEAU STREET
 OTTAWA, ONTARIO

Drawing:
LANDSCAPE SECTIONS

Scale: AS NOTED	Date: JULY 06 2020
Design By: SMc	Drawn By: SMc
Project Number: 2053-01	Sheet Number: L 2.1

L211 (Rev. 1) 03/2019 (10/11/20) 200 BaribEAU Street Residential Development (SPA) (10/11/20) 200 BaribEAU Street (10/11/20) 200 BaribEAU Street (10/11/20) 200 BaribEAU Street (10/11/20)