

THE CITY OF OTTAWA REQUIRES A Certificate of Completion (F1) Landscape Works TO BE SUBMITTED AND SEALED BY THE LANDSCAPE ARCHITECT. CONTRACTORS ARE RESPONSIBLE FOR FAMILIARIZING THEMSELVES WITH THE REQUIREMENTS OF THIS PROCESS AND PROVIDING SUFFICIENT NOTICE TO THE LANDSCAPE ARCHITECT TO CONDUCT SITE REVIEWS DURING INSTALLATION OF TREES. THE 1 YEAR WARRANTY PERIOD SHALL NOT COMMENCE UNTIL THE LANDSCAPE ARCHITECT HAS SUBMITTED THE F1 Certificate.

PRIOR TO INSTALLATION OF TREES, THE DEVELOPER WILL CONTACT THE PLANNING AND GROWTH MANAGEMENT AND FORESTRY SERVICES TO REVIEW THE SPECIES AND LOCATION OF TREES.

NOTES:

DO NOT SCALE DRAWINGS;

NOTES ARE APPLICABLE TO ALL DRAWINGS IN THE SET;

Fotenn Consultants Inc. IS NOT RESPONSIBLE FOR ACCURACY OF BASE INFORMATION;

REFER TO CIVIL ENGINEERING DRAWINGS FOR GRADING & SITE SERVICING INFORMATION;

THE CONTRACTOR IS RESPONSIBLE FOR CONFIRMING SITE CONDITIONS AND REPORTING ANY DISCREPANCIES TO THE LANDSCAPE ARCHITECT;

THE CONTRACTOR IS RESPONSIBLE FOR CONFIRMING EXACT LOCATIONS OF ALL UNDERGROUND SERVICES AND OBTAINING CLEARANCE FROM ALL APPLICABLE UTILITIES. PROPOSED WORKS FOUND TO BE IN CONFLICT WITH UNDERGROUND SERVICES MAY BE ADJUSTED AT THE DIRECTION OF THE LANDSCAPE ARCHITECT;

LANDSCAPE ELEMENTS SHOWN ARE SUBJECT TO THE FINAL LOCATION OF UNDERGROUND SERVICES AND UTILITIES;

DO NOT INSTALL TREES ON PROPERTY / LOT LINES OR WITHIN DRAINAGE EASEMENTS;

PERFORM WORK IN ACCORDANCE WITH DETAILS AND SPECIFICATIONS;

ALL PLANT MATERIAL SHALL BE No. 1 NURSERY STOCK AND SHALL MEET OR EXCEED THE SPECIFICATION OF THE Canadian Standards for Nursery Stock, AS PUBLISHED BY THE Canadian Nursery Landscape Association;

SPECIES SUBSTITUTIONS ARE NOT PERMITTED WITHOUT PRIOR WRITTEN APPROVAL OF THE LANDSCAPE ARCHITECT;

ALL UN-PAVED SURFACES TO RECEIVE 150mm DEPTH TOPSOIL & SOD.

STANDARDS FOR TREE PLANTING:

NO PLANTING ON CORNERS OR ANYWHERE WHERE IT WOULD CREATE A SIGHT LINE CONCERN;

MAINTAIN A MINIMUM DISTANCE OF 2.5m FROM THE CURB FOR DECIDUOUS TREES AND 4.5m FOR CONIFEROUS TREES;

MAINTAIN A MINIMUM DISTANCE OF 1.5m FOR DECIDUOUS (4.5m FOR CONIFERS) FROM ANY SIDEWALK OR PRIVATE WALKWAY;

MAINTAIN A MINIMUM DISTANCE OF 1.2m FROM ALL DRIVEWAYS;

MAINTAIN A MINIMUM DISTANCE OF 2.5m FROM COMMUNITY MAILBOXES, LIGHT STANDARDS, FIRE HYDRANTS AND NO PLANTING IN FRONT OF HYDRANTS;

MAINTAIN A MINIMUM DISTANCE OF 3.0m FROM ALL HYDRO TRANSFORMERS;

MAINTAIN A MINIMUM DISTANCE OF 1.0m FROM ALL UNDERGROUND SERVICES;

MAINTAIN A MINIMUM DISTANCE OF 1.0m FROM ALL BELL AND CABLE BOXES;

MAINTAIN A MINIMUM DISTANCE OF 10.0 FROM BUS SHELTERS

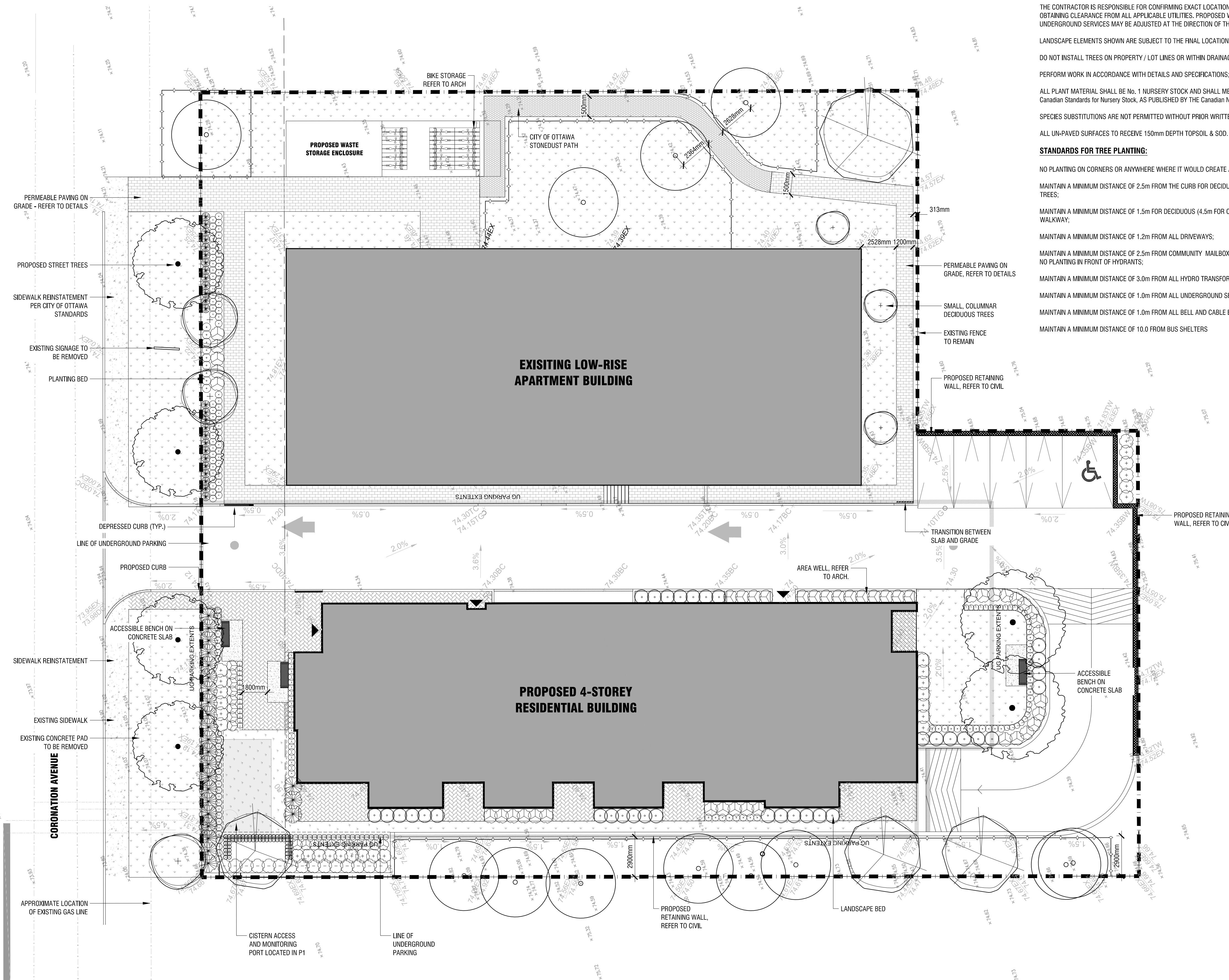

Copyright Reserved
The Copyrights to all designs and drawings are the property of Fotenn Consultants Inc. Unauthorized reproduction or use is forbidden. DO NOT SCALE DRAWING
Copyright réservés
Les droits d'auteur à tous les modèles et dessins sont la propriété de Fotenn Consultants Inc. Toute reproduction ou utilisation non autorisée est interdite. NE PAS L'ÉCHELLE DE DESSIN

Client / Client

InSpire Developments

key plan / plan repère

**PRELIMINARY
NOT FOR CONSTRUCTION**

legend / légende

	PROPERTY LINE
	EXISTING TREES TO REMAIN, REFER TO TREE CONSERVATION REPORT
	TREE PROTECTION FENCING, REFER TO TREE CONSERVATION REPORT
	DECIDUOUS TREES (SEE PLANTING NOTES & SCHEDULE FOR SPECIES AND QUANTITIES)
	PROPOSED SHRUB, PERENNIAL AND GRASSES, REFER TO PLANTING SCHEDULE
	SOD
	CITY OF OTTAWA STONEDUST PATH
	PERMEABLE PAVEMENT
	UNIT PAVING
	CONCRETE
	UNIVERSALLY ACCESSIBLE BENCH

07	issued for SPA	2021/11/11
06	issued for COORDINATION	2021/10/29
05	issued for SPA	2020/11/11
04	issued for COORDINATION	2020/11/09
03	issued for COORDINATION	2020/11/04
02	issued for COORDINATION	2020/09/25
01	issued for COORDINATION	2020/09/01

FOTENN Planning + Design
396 Cooper Street, Suite 300
Ottawa, ON, CANADA K2P 2H7
613.730.5709
fotenn.com

north / le nord stamp / le cachet

700 CORONATION AVENUE

LAYOUT PLAN

designed / conçu PM / KP	drawn / dessiné PM/MB	reviewed / examiné KP / DF
date NOVEMBER 2021		
project number / No. du projet D07-12-20-0152/D02-02-20-0114		
drawing number / No. du dessin		

InSpire Developments

key plan / plan repère

PRELIMINARY
 NOT FOR CONSTRUCTION

legend / légende

- PROPERTY LINE
- EXISTING TREES TO REMAIN, REFER TO TREE CONSERVATION REPORT
- TREE PROTECTION FENCING, REFER TO TREE CONSERVATION REPORT
- DECIDUOUS TREES (SEE PLANTING NOTES & SCHEDULE FOR SPECIES AND QUANTITIES)
- PROPOSED SHRUB, PERENNIAL AND GRASSES. REFER TO PLANTING SCHEDULE
- SOD
- CITY OF OTTAWA STONEDUST PATH
- PERMEABLE PAVEMENT
- UNIT PAVING
- CONCRETE
- UNIVERSALLY ACCESSIBLE BENCH

07	issued for SPA	2021/11/11
06	issued for COORDINATION	2021/10/29
05	issued for SPA	2020/11/11
04	issued for COORDINATION	2020/11/09
03	issued for COORDINATION	2020/11/04
02	issued for COORDINATION	2020/09/25
01	issued for COORDINATION	2020/09/01

rev'n	description / la description	yyyy/mm/dd
-------	------------------------------	------------

FOTENN Planning + Design
 396 Cooper Street, Suite 300
 Ottawa, ON, CANADA K2P 2H7
 613.730.5709
 fotenn.com

north / le nord

stamp / le cachet



project / projet

700 CORONATION AVENUE

drawing / dessin

PLANTING PLAN

designed / conçu	drawn / dessiné	reviewed / examiné
PM / KP	PM/MB	KP / DF
date	project number / No. du projet	
NOVEMBER 2021	D07-12-20-0152/D02-02-20-0114	
drawing number / No. du dessin		

L2 of 3

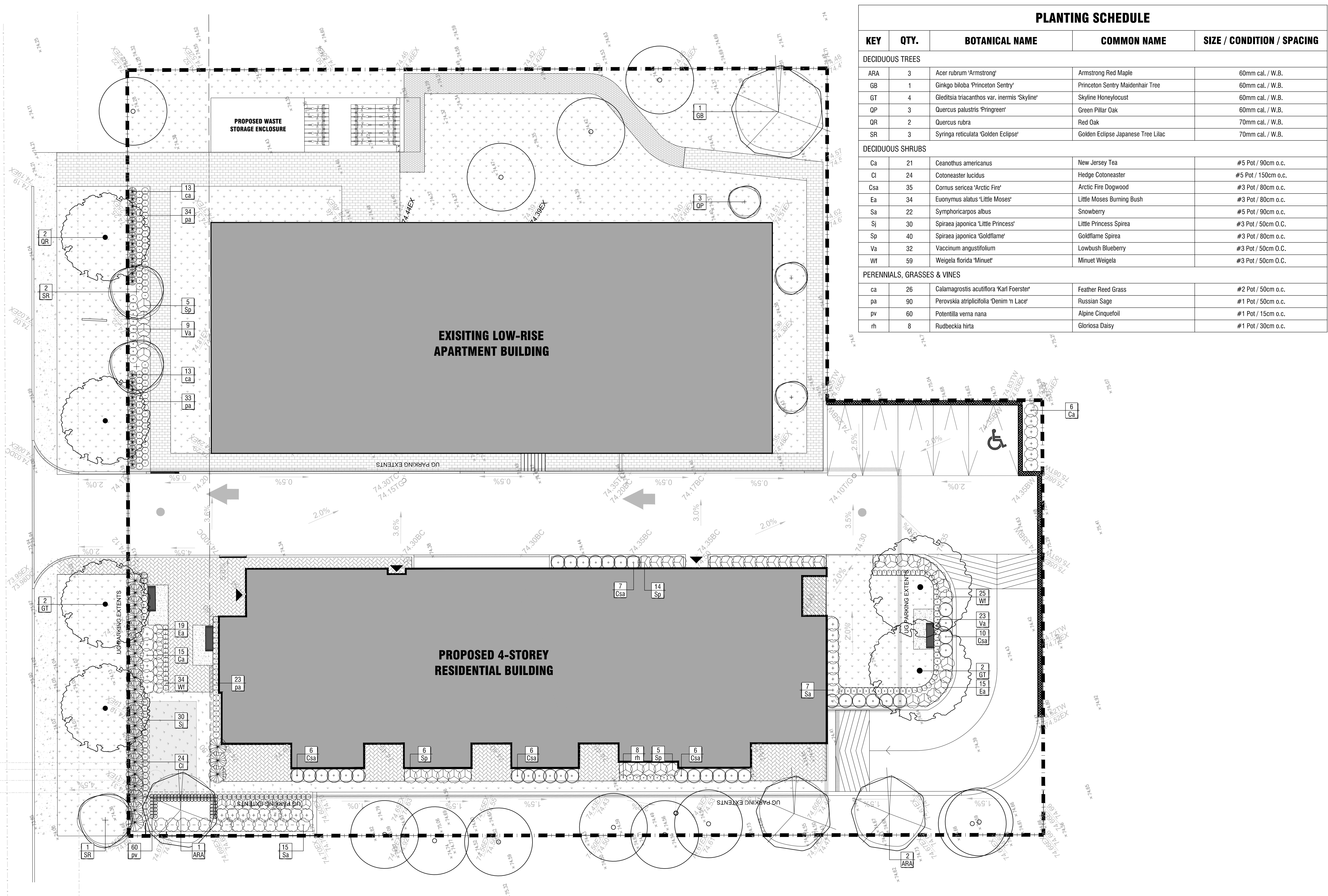

PLANTING SCHEDULE				
KEY	QTY.	BOTANICAL NAME	COMMON NAME	SIZE / CONDITION / SPACING
DECIDUOUS TREES				
ARA	3	Acer rubrum 'Armstrong'	Armstrong Red Maple	60mm cal. / W.B.
GB	1	Ginkgo biloba 'Princeton Sentry'	Princeton Sentry Maidenhair Tree	60mm cal. / W.B.
GT	4	Gleditsia triacanthos var. inermis 'Skyline'	Skyline Honeylocust	60mm cal. / W.B.
OP	3	Quercus palustris 'Pringreen'	Green Pillar Oak	60mm cal. / W.B.
OR	2	Quercus rubra	Red Oak	70mm cal. / W.B.
SR	3	Syringa reticulata 'Golden Eclipse'	Golden Eclipse Japanese Tree Lilac	70mm cal. / W.B.
DECIDUOUS SHRUBS				
Ca	21	Ceanothus americanus	New Jersey Tea	#5 Pot / 90cm o.c.
Cl	24	Cotoneaster lucidus	Hedge Cotoneaster	#5 Pot / 150cm o.c.
Csa	35	Cornus sericea 'Arctic Fire'	Arctic Fire Dogwood	#3 Pot / 80cm o.c.
Ea	34	Euonymus alatus 'Little Moses'	Little Moses Burning Bush	#3 Pot / 80cm o.c.
Sa	22	Symphoricarpos albus	Snowberry	#5 Pot / 90cm o.c.
Sj	30	Spiraea japonica 'Little Princess'	Little Princess Spirea	#3 Pot / 50cm O.C.
Sp	40	Spiraea japonica 'Goldflame'	Goldflame Spirea	#3 Pot / 80cm o.c.
Va	32	Vaccinium angustifolium	Lowbush Blueberry	#3 Pot / 50cm O.C.
Wf	59	Weigela florida 'Minuet'	Minuet Weigela	#3 Pot / 50cm O.C.
PERENNIALS, GRASSES & VINES				
ca	26	Calamagrostis acutiflora 'Karl Foerster'	Feather Reed Grass	#2 Pot / 50cm o.c.
pa	90	Perovskia atriplicifolia 'Denim 'n Lace'	Russian Sage	#1 Pot / 50cm o.c.
pv	60	Potentilla verna nana	Alpine Cinquefoil	#1 Pot / 15cm o.c.
rh	8	Rudbeckia hirta	Gloriosa Daisy	#1 Pot / 30cm o.c.

1 PLANTING PLAN
L2 1:150

PRELIMINARY
 NOT FOR CONSTRUCTION

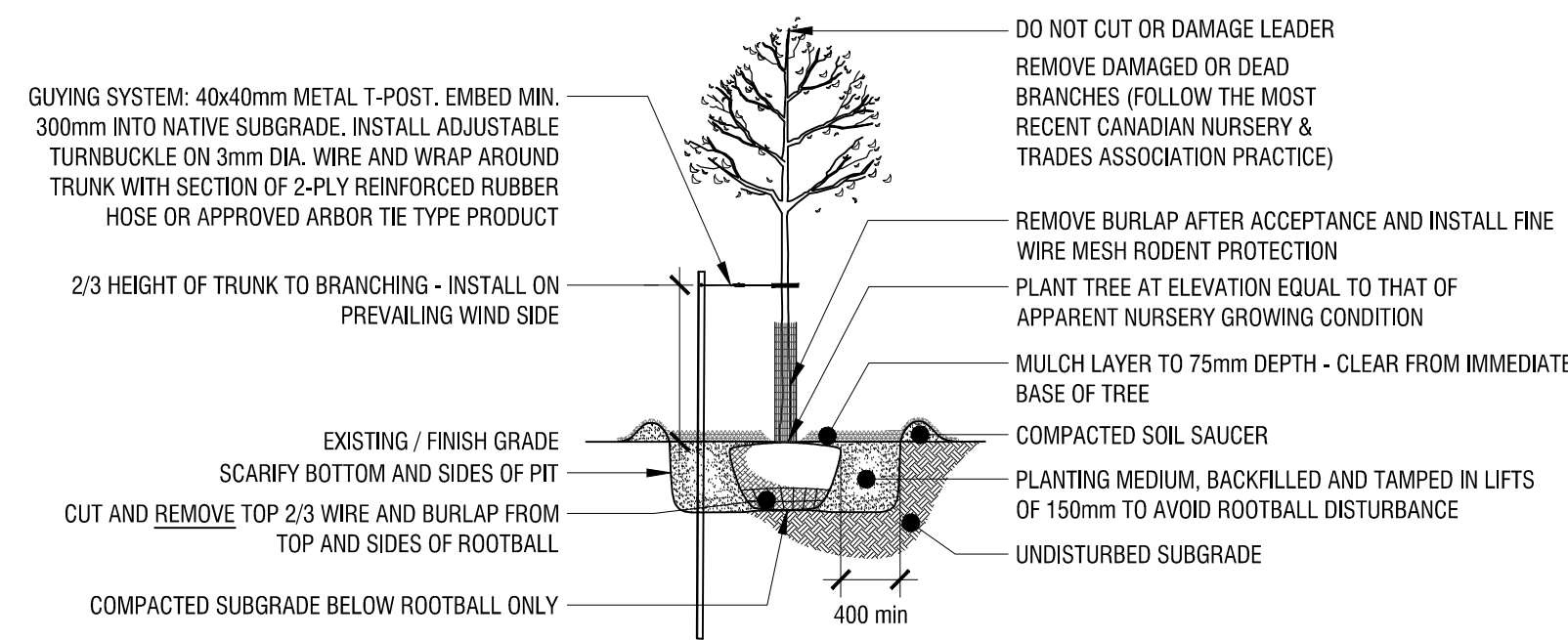

1 DECIDUOUS TREE PLANTING DETAIL

L3 n.t.s.

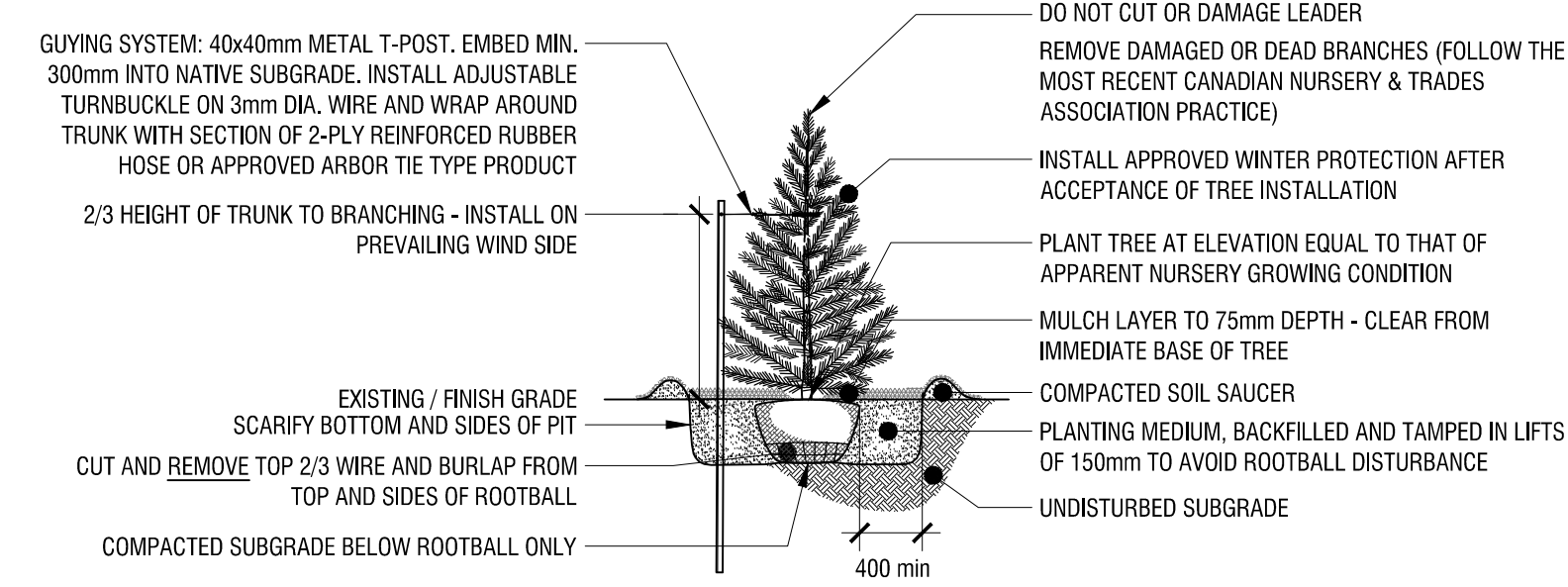

2 CONIFEROUS TREE PLANTING DETAIL

L3 n.t.s.

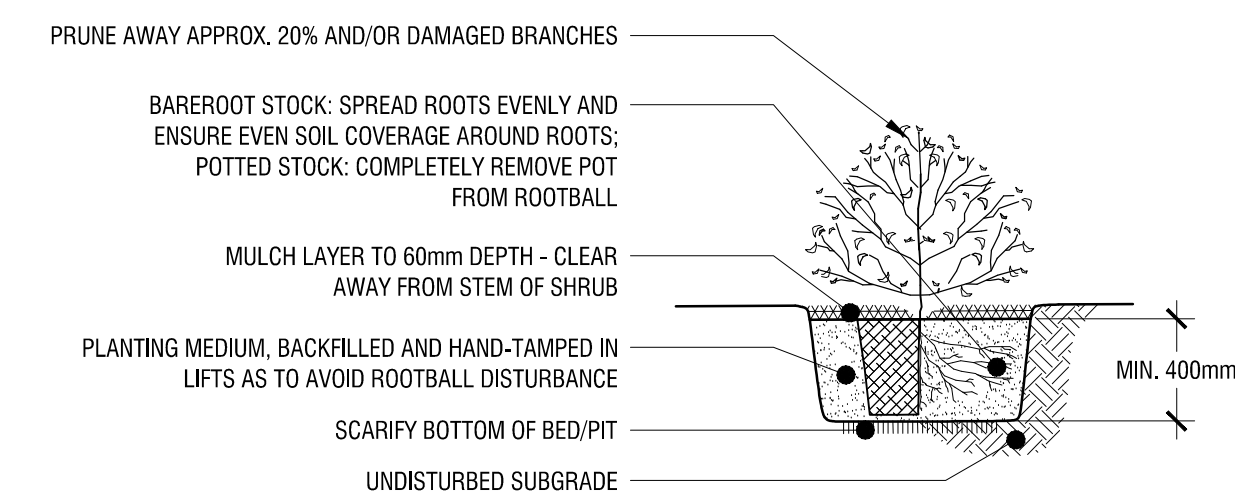

3 SHRUB PLANTING DETAIL

L3 n.t.s.

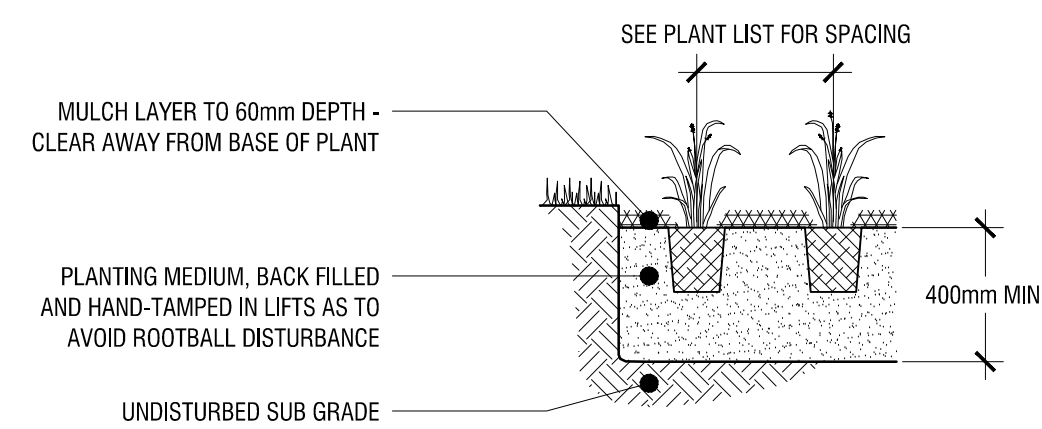

4 PERENNIAL PLANTING DETAIL

L3 n.t.s.

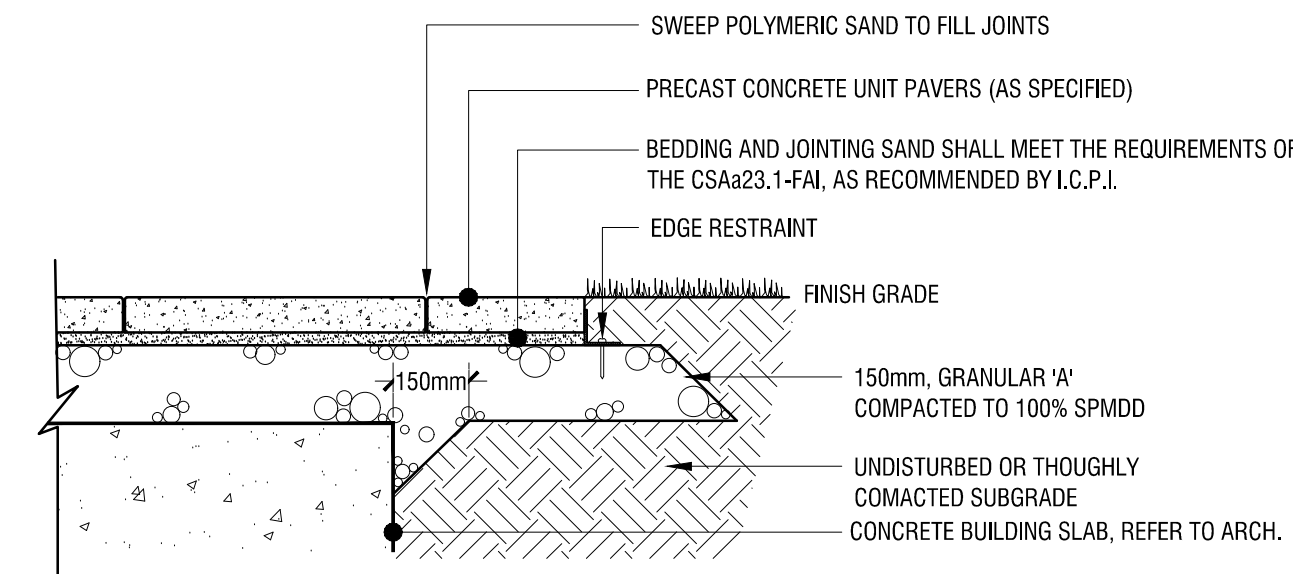

5 LIGHT DUTY PRE-CAST UNIT PAVING

L3 1:15

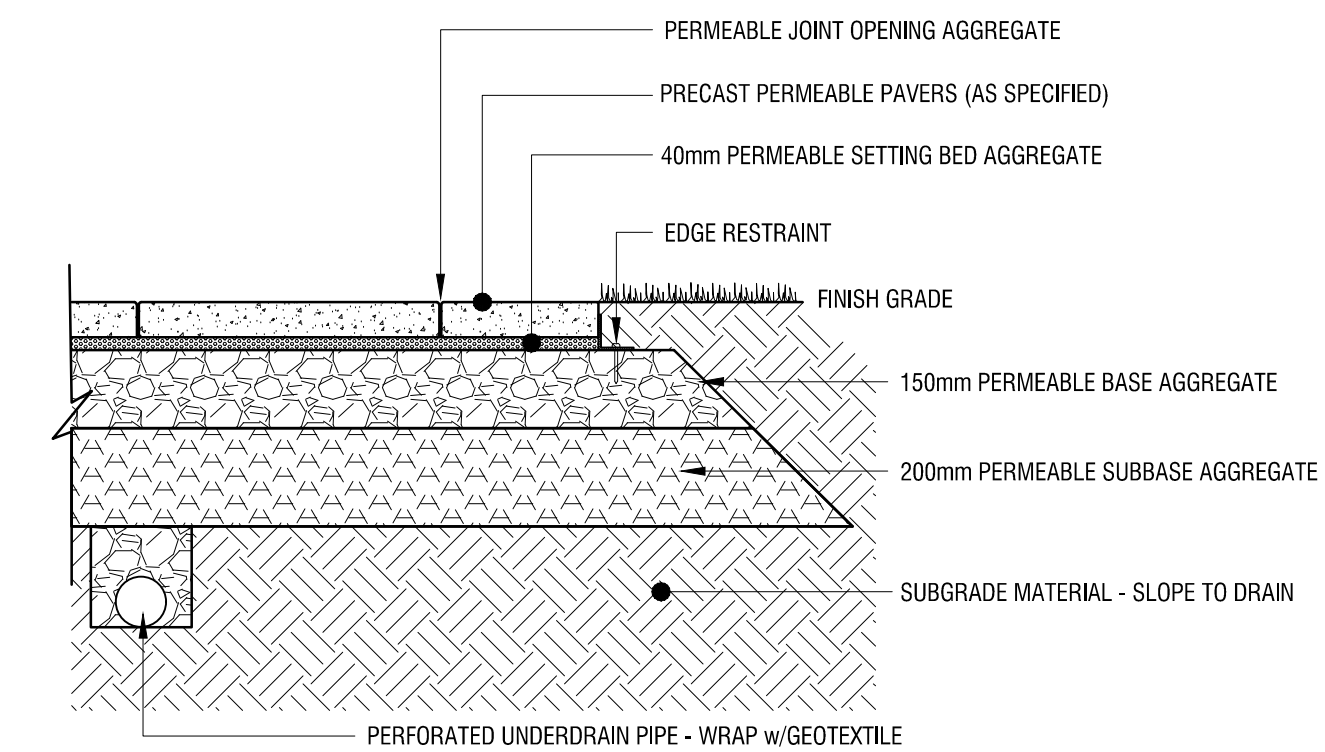

6 PERMEABLE PAVEMENT

L3 1:15

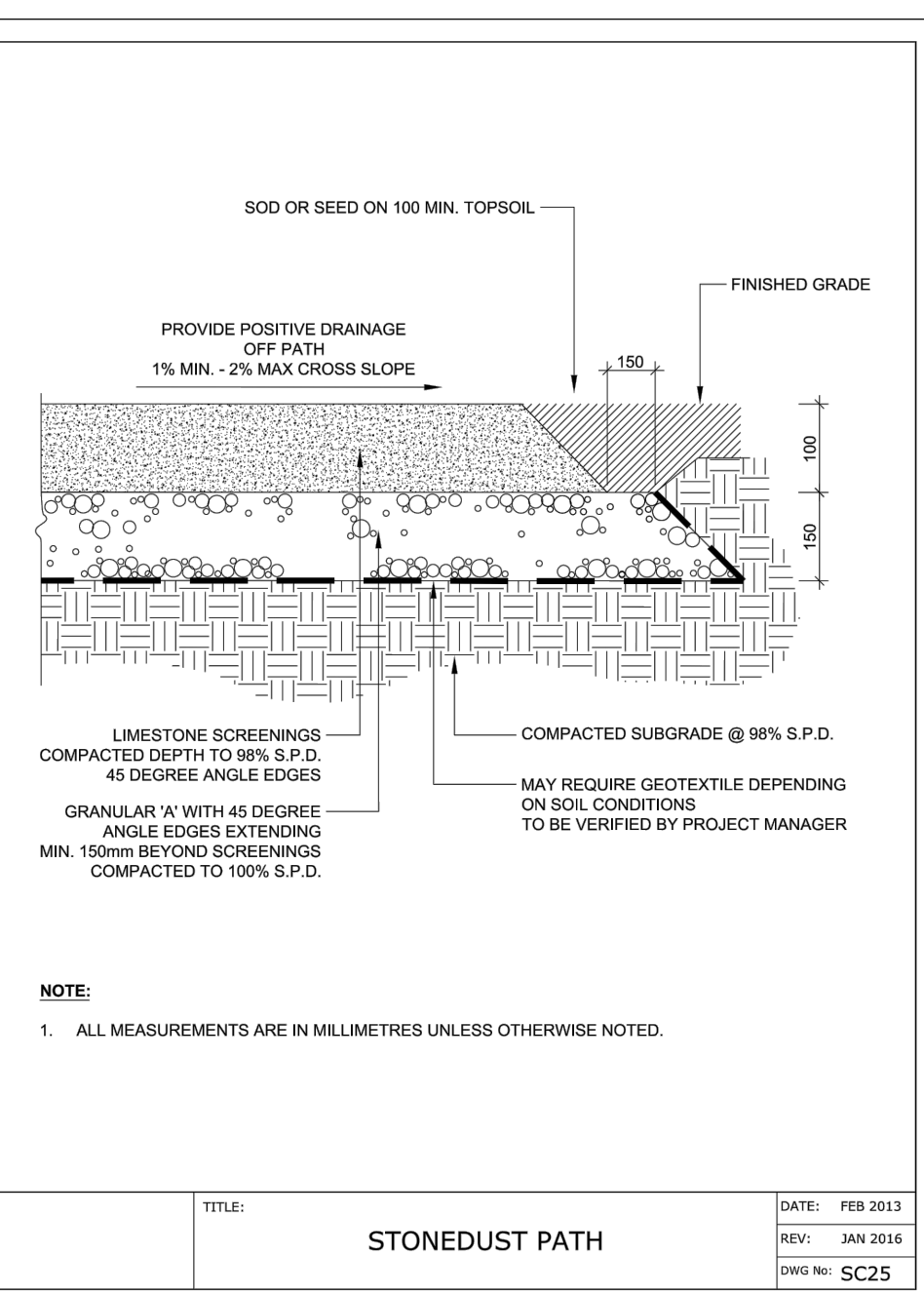

7 CITY OF OTTAWA STONEDUST PATH

L3 nts

rev'n	description / la description	yyyy/mm/dd
07	issued for SPA	2021/11/11
06	issued for COORDINATION	2021/10/29
05	issued for SPA	2020/11/11
04	issued for COORDINATION	2020/11/09
03	issued for COORDINATION	2020/11/04
02	issued for COORDINATION	2020/09/25
01	issued for COORDINATION	2020/09/01

FOTENN Planning + Design
 396 Cooper Street, Suite 300
 Ottawa, ON, CANADA K2P 2H7
 613.730.5709
 fotenn.com

north / le nord stamp / le cachet

project / projet

700 CORONATION AVENUE

drawing / dessin

CONSTRUCTION DETAILS

designed / conçu	drawn / dessiné	reviewed / examiné
PM / KP	PM/MB	KP / DF
date	project number / No. du projet	
NOVEMBER 2021	D07-12-20-0152/D02-02-20-0114	
drawing number / No. du dessin		