

Bayview Hospitality Holdings Ltd

# 6301 Campeau Drive Stormwater Management Report

May 28, 2021





# 6301 Campeau Drive Stormwater Management Report

Bayview Hospitality Holdings Ltd

Confidential  
Issue for City Review  
Project No.: 201-03048-00  
Date: May 28, 2021

WSP  
Suite 300  
2611 Queensview Drive  
Ottawa, ON, Canada K2B 8K2

T: +1 613 829-2800  
F: +1 613 829-8299  
wsp.com

# Revision History

## FIRST ISSUE

December 4, 2020	First Submission			
Prepared by	Reviewed by	Approved By		
Michael Stewart, M.A.Sc., E.I.T. Water Resources E.I.T.	Ben Worth, P.Eng., C.Eng., MICE Manager, Water Resources	Ben Worth, P.Eng., C.Eng., MICE Manager, Water Resources		
May 20, 2021	Second Submission			
Prepared by	Reviewed by	Approved By		
Michael Stewart, M.A.Sc., P.Eng. Project Engineer	Michelle Hughes, P.Eng. Manager, Water Resources	Michelle Hughes, P.Eng. Manager, Water Resources		

---

# Signatures

Prepared by



Michael Stewart, M.A.Sc., P.Eng.  
Project Engineer

May 27, 2021

Date

APPROVED BY



Michelle Hughes, P.Eng.  
Manager, Water Resources

May 27, 2021

Date

WSP Canada Inc. prepared this report solely for the use of the intended recipient, Bayview Hospitality Holdings Ltd, in accordance with the professional services agreement. The intended recipient is solely responsible for the disclosure of any information contained in this report. The content and opinions contained in the present report are based on the observations and/or information available to WSP Canada Inc. at the time of preparation. If a third party makes use of, relies on, or makes decisions in accordance with this report, said third party is solely responsible for such use, reliance or decisions. WSP Canada Inc. does not accept responsibility for damages, if any, suffered by any third party as a result of decisions made or actions taken by said third party based on this report. This limitations statement is considered an integral part of this report.

The original of this digital file will be conserved by WSP Canada Inc. for a period of not less than 10 years. As the digital file transmitted to the intended recipient is no longer under the control of WSP Canada Inc., its integrity cannot be assured. As such, WSP Canada Inc. does not guarantee any modifications made to this digital file subsequent to its transmission to the intended recipient.



# TABLE OF CONTENTS

<b>1</b>	<b>INTRODUCTION.....</b>	<b>1</b>
1.1	Scope .....	1
1.2	Site Location .....	1
1.3	Stormwater Management Plan Objectives .....	2
1.4	Design Criteria .....	2
1.4.1	Stormwater management criteria for lands draining toward the Kanata Lakes Golf Course Development.....	3
1.4.2	Stormwater management criteria for lands draining toward the Kanata Town Centre SWMF.....	4
<b>2</b>	<b>PRE-DEVELOPMENT CONDITIONS .....</b>	<b>6</b>
2.1	General .....	6
2.2	Rainfall Information .....	6
2.3	Allowable Flow Rates – Parcel 1 .....	6
2.4	Allowable Flow Rates – Parcel 2.....	7
<b>3</b>	<b>POST-DEVELOPMENT CONDITIONS.....</b>	<b>9</b>
3.1	General .....	9
3.2	Water Quality – Parcel 1 .....	9
3.3	Water Quantity – Parcel 1 .....	9
3.4	Water Quantity – Parcel 2 .....	12
<b>4</b>	<b>CONCLUSIONS.....</b>	<b>15</b>

---

*Tables*

Table 2-1: Pre-Development Peak Flow Rate Calculations for flows to Campeau Drive (Runoff Coefficient, $C = 0.20$ and $T_c=20$ min) .....	7
Table 2-2: Summary of Parcel 2 Criteria .....	8
Table 2-3: Post-Development Peak Flow Rate Calculations to Cordillera Street (Runoff Coefficient, $C = 0.80$ and $T_c=20$ min).....	8
Table 3-1: Summary of Modelling Results ....	11
Table 3-2: Summary of Modelling Results ....	14

---

*Figures*

Figure 1-1: Site Location .....	1
Figure 1-2: Approximate Stormwater Management Boundaries .....	3

---

## *Appendices*

### **A** City Correspondence

A-1 Pre-consultation Meeting Minutes (November 8, 2019)

A-2 E-mail Correspondence (April 8, 2021)

### **B** Relevant excerpts from background studies and reports

B-1 Stormwater Catchment Draining to Kanata Lakes Golf Course Development

B-2 Stormwater Catchments Draining to Kanata Town Centre SWMF

B-3 Minor System Capacity for Lands Draining to Kanata Town Centre SWMF

### **C** Existing Site Conditions

### **D** Stormwater Management Calculations

D-1 Pre-development Calculations

D-2 Post-Development Calculations

### **E** Proposed Site – Annotated Storm Drainage Plan

### **F** Product Calculations and Documentation

F-1 Roof Drains

F-2 Parcel 1 Oil-Grit Separator

### **G** Parcel 1 – Model Output (HydroCAD)

G-1 Parcel 1: 5-Year Analysis (Peak Discharge)

G-2 Parcel 1: 100-Year Analysis (Peak Discharge)

G-3 Parcel 1: 100-Year Analysis (Peak Storage)

### **H** Parcel 2 - Model Output (PCSWMM)

# 1 INTRODUCTION

---

## 1.1 Scope

WSP Canada Inc. was retained by Bayview Hospitality Group to conduct a stormwater management study to service the proposed new residential development, including apartments and townhouses.

---

## 1.2 Site Location

The existing site is located at 6301 Campeau Drive, Ottawa, Ontario, bounded by Campeau Drive to the north, Cordillera Street to the east, future Canadian Shield Avenue to the south, and an existing property at 6501 Campeau Drive to the west. The location of the proposed re-development is split into two parcels and is illustrated in **Figure 1-1**.

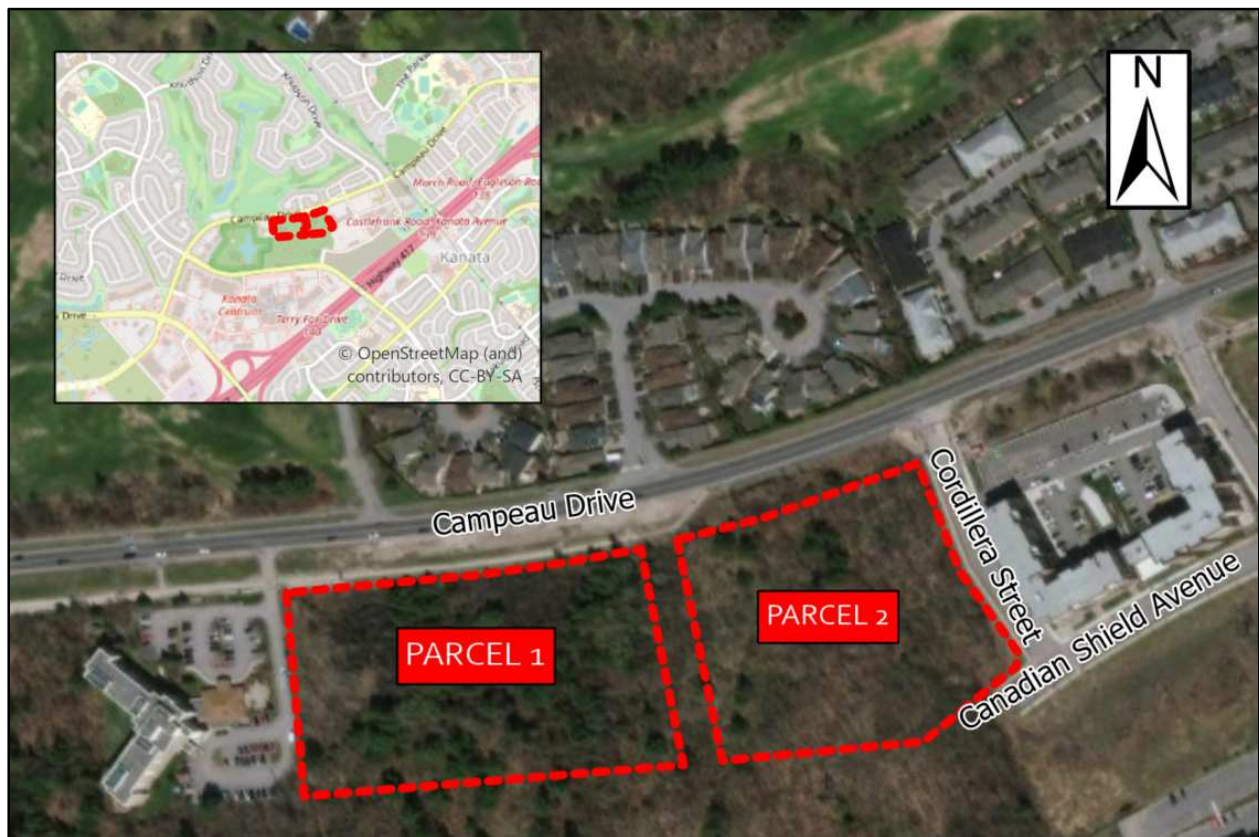

**Figure 1-1: Site Location**



---

## 1.3 Stormwater Management Plan Objectives

The objectives of the stormwater management (SWM) study are as follows:

- Collect and review background information.
- Determine site specific stormwater management requirements to ensure that future development projects are in line with Bayview Hospitality Holdings Ltd’s vision for the site and conform with the requirements of the City, Mississippi Valley Conservation Authority (MVCA), and established reports.
- Ensure downstream capacity is sufficient for receiving allowed discharge.
- Evaluate various stormwater management practices that meet the stormwater management requirements and recommend a preferred stormwater management strategy.

---

## 1.4 Design Criteria

There are two sets of stormwater management criteria for 6301 Campeau drive as governed by the pre-development drainage boundaries and the existing drainage strategies of adjacent developments. The criteria for these two areas were discussed in a pre-consultation meeting with the City, owner (OCLDC), and development applicant (Bayview Hospitality Inc.) dated November 8, 2019 (**Appendix A**) and supported by the following stormwater management reports and resources:

- 1 Kanata Town Centre Phasing and Servicing Overview by IBI (September 23, 2013)
- 2 Stormwater Management Report, Kanata Town Centre, Central Business District by J.L. Richards & Associates Limited (January 1999)
- 3 [Kanata Lakes Golf Course Development Application](#): Preliminary Stormwater Management Plan Technical Memo, JFSA (July 9, 2020) and Functional Servicing Report for 7000 Campeau Drive, DSEL (July 2020)
- 4 Further discussions with the City (**Appendix A**) and ongoing communication.

Select figures and tables from the above reports detailing storm drainage boundaries have been provided in **Appendix B**. PDFs from the reports have been overlain and traced to show their relation to the proposed development boundaries in **Figure 2**.

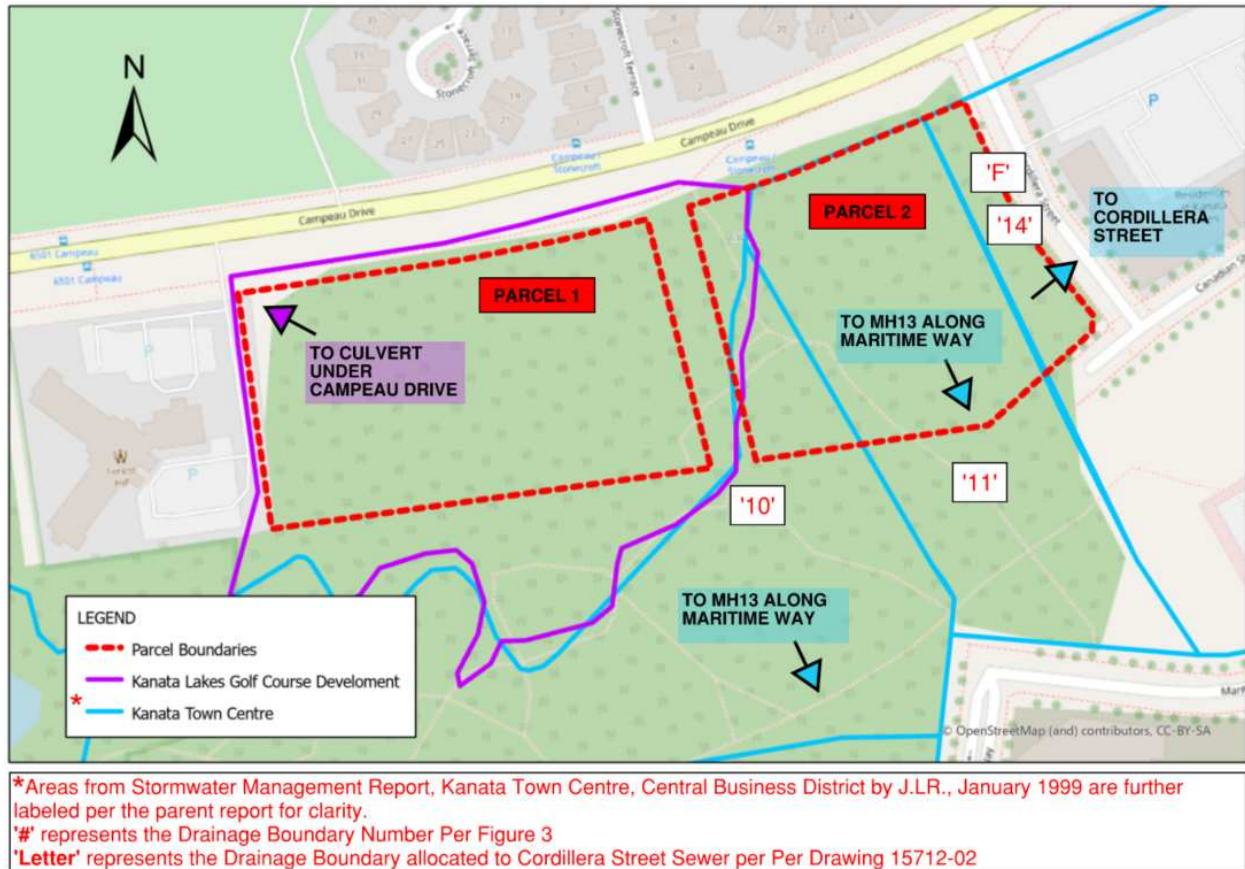

**Figure 1-2: Approximate Stormwater Management Boundaries**

All of Parcel 1 lands and a portion of Parcel 2 are governed by the criteria set forward by the Kanata Lakes Golf Course development (purple) whereas the majority of parcel 2 is governed by drainage captured by the Kanata Town Centre SWMF (blue).

### 1.4.1 Stormwater management criteria for lands draining toward the Kanata Lakes Golf Course Development

The first set of criteria is detailed in the *Kanata Town Centre Phasing and Servicing Overview by IBI (September 23, 2013)* and *Kanata Lakes Development Application Documents (2020)*. These criteria are for the lands draining northwest toward Campeau Drive.

The following are key points regarding the stormwater servicing from this report:

- The existing storm sewer along Campeau Drive adjacent to Parcel 1 is a shallow sewer designed to capture roadway drainage and has no identified capacity for receiving drainage from additional developments
- A 1200 mm diameter culvert crossing Campeau drive exists at the northwest edge of the site. “This storm outlet is directly available to Blocks A to D inclusive. On-site

attenuation to predevelopment flow should be considered a requirement for the purposes of advancing use of this storm outlet”

## CRITERIA

**Water Quality** – Water quality is proposed to be accommodated by SWMFs within the Kanata Lakes Golf Course development north of Campeau Drive. If the development of Kanata Lakes Golf Course does not proceed, treatment of parcel 1 lands will need to be provided with an annual removal of 80% TSS (Enhanced Level Treatment).

**Water Quantity Control and Discharge to Municipal Infrastructure** – Runoff from the 5-year to 100-year design storms must not exceed the peak 5-year pre-development flow rate with a runoff coefficient of 0.20.

### 1.4.2 Stormwater management criteria for lands draining toward the Kanata Town Centre SWMF

The second set of criteria is detailed in *Stormwater Management Report, Kanata Town Centre, Central Business District* by J.L. Richards & Associates Limited (January 1999).

The following are key points regarding the stormwater servicing from this report:

- Lands are accommodated by a major/ minor storm system discharging to a SWMF in the southeast corner of the Kanata Town Centre development.
- The proposed development at 6301 Campeau Drive sits within three separate drainage areas; two of which are accounted for at a maintenance hole along Marine Way (by way of Canadian Shield Avenue) and one of which is accounted for along Cordillera Avenue.

## CRITERIA

**Water Quality** – Water quality is accommodated by the SWMF in the southeast of the Kanata Town Centre. The facility was designed to a level of 86% sediment removal based on N.U.R.O. settling curves per J.L. Richards & Associates Limited (January 1999). Therefore, there is no water quality target for Parcel 2.

### **Water Quantity Control and Discharge to Municipal Infrastructure** –

Correspondence on April 8, 2021 with the City of Ottawa (**Appendix A**) states that the sewer capacity (60 L/s) along Cordillera Street as read by the City’s stormwater model governs the allowable release rate for the site for runoff to Cordillera Street during the 100-year storm. Further discussions in a meeting on May 7, 2021 indicate that 10-year on site storage is acceptable, provided overflow to Cordillera Street remains within tolerable flow depths and velocities.

Flows to Canadian Shield Avenue do not need to be controlled as they are largely undeveloped, but they must follow three conditions: **1-** In the interim, prior to the full build out of Canadian Shield Avenue, the overland flow path must remain within the public right of way to Maritime Way and **2-** 5-year flows must be connected to the minor system along Canadian Shield Avenue and **3-** 100-year flows along the future Canadian Shield Avenue must remain within tolerable flow depths and velocities per the City of Ottawa Sewer Guidelines, 8.3.9.3.

# 2 PRE-DEVELOPMENT CONDITIONS

---

## 2.1 General

Currently the land proposed for the residential development is undeveloped, mainly covered by grass and tress, and forms part of the Kanata Town Centre development lands. The total study area for Parcels 1 and 2 are 1.964 and 1.741 ha, respectively. Please refer to **Appendix C** for existing site conditions as provided by the Topographical Survey Plan by Annis, O'Sullivan, Vollebekk Ltd. (February 2020).

---

## 2.2 Rainfall Information

The rainfall intensity is calculated in accordance with Section 5.4.2 of the Ottawa Sewer Design Guidelines (October 2012):

$$i = \left[ \frac{A}{(T_d + C)^B} \right]$$

Where;

- A, B, C = regression constants for each return period (defined in section 5.4.2)
  - i = rainfall intensity (mm/hour)
  - T<sub>d</sub> = storm duration (minutes)
  - The IDF parameters/regression constants are included in **Appendix D**.
- 

## 2.3 Allowable Flow Rates – Parcel 1

As noted in **Section 1.4.1**, post-development stormwater runoff from the 5-year to 100-year design storms must not exceed the peak 5-year pre-development flow rate with a runoff coefficient value of 0.20.

The total site area draining through the site is 3.09 ha. This area will discharge to a 750mm storm pipe at the northwest edge of the site which ultimately drains through a culvert toward the Kanata Lakes Development (previously golf course lands). Of the 3.09 ha draining to the boundary of the site, the undeveloped area (1.29 ha) will be routed through a swale with underdrain downstream of proposed site controls (i.e. bypassing the system and remaining unchanged from existing conditions). Therefore, only the remaining 1.8 ha. were included in the pre /post-development allowable release

rates. The calculated peak flow rates for the site in the pre-development condition are summarized below and shown in **Appendix D**.

**Table 2-1: Pre-Development Peak Flow Rate Calculations for flows to Campeau Drive (Runoff Coefficient, C = 0.20 and T<sub>c</sub>=20 min)**

Return Period (Years)	Rainfall Intensity (MM/hour)	Peak Flow Rate (l/s)	Target Release Rate (l/s)
<b>2</b>	52.0	52.0	<b>70.3</b>
<b>5</b>	70.3	<b>70.3</b>	
<b>10</b>	82.2	82.2	
<b>25</b>	97.3	107.0	
<b>50</b>	108.5	130.2	
<b>100</b>	120.0	149.9	

## 2.4 Allowable Flow Rates – Parcel 2

The northwest corner of the site (**Figure 2**) will remain undeveloped and drains through Parcel 1 in accordance with the criteria set out in **Section 2.3**. The remaining site area which was accounted for by J.L. Richards (January 1999) during the design of the Kanata Town Centre minor system. However, this report **1-** assumed Canadian Shield Avenue would be fully constructed prior to the development of this parcel and **2-** was established prior to current City of Ottawa standards and practices for overland flow.

In this Report (J.L. Richards, 1999) which was used as a high level plan for the Kanata Town Centre storm system (major and minor) the majority of site area was accounted for in 'Maintenance hole 13' along Maritime Way (areas '10' and '11' from **Figure 2**), the roadway and associated minor pipe systems along Canadian Shield Avenue which tie into Maritime Way have not yet been constructed. The remaining 0.25 ha. (area '14' or 'F' from **Figure 2**) of site area has been accounted for in the design of the minor system along Cordillera Street. However, since Canadian Shield Avenue is not yet constructed, all site areas not draining toward Cordillera Street must be controlled to criteria deemed acceptable by the City (**Appendix A and ongoing discussions**) in order to provide a safe and functional system. Flows draining to Canadian Shield Avenue are largely undeveloped. Per the City of Ottawa Guidelines (8.3.9.3), flow depth x velocity must remain below 0.6 to be considered safe. The City of Ottawa will be checking the downstream flow path for both Canadian Shield Avenue and Canadian Shield Avenue.

A summary of the Parcel 2 Criteria is provided (**Table 2-2**) as described in **Section 1.4.2**.

**Table 2-2: Summary of Parcel 2 Criteria**

Return Period (Years)	Flow to Cordillera Street	Flow to Canadian Shield Avenue prior to build out	Flow to Canadian Shield after build out of roadway
<b>5</b>	Storage must be provided to limit offsite flows to 60 L/s	Flow must remain within an acceptable path to Maritime Way (through future ROW)	Flows routed to sewer
<b>10</b>	Storage must be provided to limit offsite flows to 60 L/s		Excess flows may be routed along the roadway but must remain within tolerable depths and velocities
<b>100</b>	Any excess flows over the 10-year release rate to the roadway must remain within tolerable depths and velocities		

The calculated peak flow rates for the site to Cordillera Street (0.25 ha) and the future Canadian Shield Avenue (1.49 ha) in the 5-year storm, which align with the flow rates provided in the report by J.L. Richards (1999) are summarized below in **Table 2-3** for Cordillera Street. Detailed calculations are contained within **Appendix D**.

**Table 2-3: Post-Development Peak Flow Rate Calculations to Cordillera Street (Runoff Coefficient, C = 0.80 and T<sub>c</sub>=20 min)**

Return Period (Years)	Rainfall Intensity (MM/hour)	Peak Flow Rate (l/s)	Target Release Rate (l/s)
<b>2</b>	52.0	29.0	<b>39.1</b>
<b>5</b>	70.3	<b>39.1</b>	
<b>10</b>	82.2	45.8	
<b>25</b>	97.3	59.6	
<b>50</b>	108.5	72.5	
<b>100</b>	120.0	83.5	

# 3 POST-DEVELOPMENT CONDITIONS

---

## 3.1 General

The two parcels each have new proposed residential developments, including apartments and townhouses. Please refer to **Appendix E** for an illustration of the project (Storm Drainage Area Plan).

The following assumptions have been used to quantify stormwater runoff for modelling/analysis purposes: 100% of proposed apartment roof surfaces have been considered as impervious, and 100% of the rooftop area of each of these apartment buildings will be available for temporary surface ponding (via drainage by controlled discharge roof drains).

Each parcel will comply with their respective allowable release rates; 100-year discharge from Parcel 1 excluding undeveloped areas routed around the site will be limited to 70.3 L/s and 5-year minor-system discharge from Parcel 2 will be limited to 60 L/s along Cordillera Street in the 10-year storm.

---

## 3.2 Water Quality – Parcel 1

Water quality is proposed to be accommodated within SWM Pond 1 and subsequent OGS 1 of the Kanata Lakes Golf Course development north of Campeau Drive. In the event that this development is not constructed, Parcel 1 must provision for water quality treatment prior to discharge. The preferred method for treatment for this parcel is an OGS unit downstream of roof and cistern controls. A preliminary sizing for a proposed OGS designed to meet a TSS removal of 80% has been provided in **Appendix F**.

---

## 3.3 Water Quantity – Parcel 1

As noted in **Section 2.3**, the target allowable discharge rate discharging to the to Campeau Drive excluding undeveloped areas routed around the site is 70.3 l/s. This is equivalent to the peak runoff rate under pre-development conditions during a 5-year design storm event with a runoff coefficient of 0.20. Compliance with the 100-yr target offsite discharge rate will be achieved through use of rooftop ponding on the apartment building with flow control drains, pipe storage, and the provision of an underground cistern storage structure. Post-development runoff calculations have accounted for uncontrolled runoff from portions of the site that will not drain to storage features.



Most water quantity control will be provided with the provision of an underground storage cistern and upstream pipe storage. This system will be designed to receive runoff (for all events up to and including the 100-year return period) from the townhouses fronting onto Campeau Drive and at-grade areas within the development **Appendix E** illustrates the small portions of the project site that will drain offsite uncontrolled in post-development conditions. These uncontrolled runoff rates contribute to the total allowable release rate modelled. Storage was calculated using HydroCAD (**Appendix G**).

The cistern will discharge to Campeau Drive via gravity, and peak outflow rates will be controlled via an orifice control device. Sizing was completed iteratively using HydroCAD (**Appendix G**) and checked in Excel (**Appendix D**). To satisfy net target release rates for controlled and uncontrolled site areas, the recommended peak discharge rate for flow control device is 29.37 l/s (at HGL = Top of cistern). A 122 mm diameter circular orifice has been specified to meet the target release rate. It is important to note that an “HGL = Top of Cistern” would represent a design event greater than the 100-year storm and that the return period associated with an overflow event requiring these facilities to spill would exceed 100-years.

The apartment building will provide its own stormwater detention through use of temporary surface ponding. It has been assumed that 98% of the apartment building rooftop will be available for ponding with 7 roof drains provided per AutoCAD roof plans provided by API Consultants on April 30, 2021. For modelling purposes, these outlets were simulated using rating curves for a *Watts Accutrol* product (in the “3/4 exposed” position, **Appendix F**). Controlled runoff from the roof is directed downstream of the cistern storage structure.

As mentioned above, flows from the proposed townhouses fronting onto Campeau Drive will be directed to the stormwater cistern instead of being released directly to Campeau Drive. Foundation drains will be connected to a secondary pipe system which will discharge downstream of system controls to protect foundations from backups in the cistern.

Largely undeveloped lands at the south and eastern sides of the building are routed around the site. The portions of land with some development (i.e. A-108b and A-109a) are counted toward uncontrolled flows leaving the site. Various methods for time of concentration were tested (**Appendix D-2**) including Kinematic Wave Equation, Bransby Williams Equation, and the Federal Aviation Agency were tested. Since the Federal Aviation Agency time of concentration was quite large (61 minutes), it was considered an outlier and ignored. The average time of concentration from the remaining methods, 17.2 minutes, was applied to the lands draining around the site. All

remaining developed areas (i.e. parking lot, building roof etc.) has a time of concentration of 10 minutes.

A HydroCAD model of the project was constructed and utilized to include:

- storage and controlled release of stormwater from apartment rooftop areas on 63% of the rooftop area downstream of the cistern
- controlled runoff from at-grade areas directed to pipe storage + cistern
- controlled runoff from townhouse areas directed to pipe storage + cistern
- uncontrolled runoff rates generated from at grade areas constructed with soft and hard landscaping
- uncontrolled runoff rates generated from undeveloped areas routed around site

The Modified Rational Method (an inherent subroutine of the HydroCAD software) has been used for the modelling exercise, and the model has informed the maximum storage volume used in the stormwater cistern based on the proposed flow. The peak flow rate generated from uncontrolled drainage areas within the project site and controlled flow from the cistern, pipe storage, and rooftops is 70.4 l/s which is a slight exceedance to the allowable 100-year release rate of 70.3 l/s. Modelling results are summarized below in **Table 3-1** and shown in **Appendix G**.

**Table 3-1: Summary of Modelling Results**

Return Period (Years)	Storm Duration (min)	Utilized Cistern / Pipe / Roof Storage (m <sup>3</sup> )	Peak Water Elevation in Cistern (m)	Un-developed Bypass Flows (L/s)	Controlled Flow Rate from Cistern (L/s)	Controlled Flow Rate from Roof (L/s)	Uncontrolled Flow from the site (L/s)	Total Flow Leaving Site** (L/s)	Allowable 100-yr Flow Rate (L/s)
5 (Peak Discharge)	18	150.1 1.7 69.1	103.501	53.8	16.6	7.9	18.9	40.4	<b>69.4</b>
100 (Peak Discharge)	10	325.8 3.8 137.0	103.832	115.3	24.4	9.9	40.6	<b>70.4</b>	
100 (Peak Storage)	111	454.7 4.2 191.1	104.075	31.4	28.8	11.0	11.1	50.4	

\*For detailed calculations of Time of Concentration, see **Appendix D**

\*\*Total Flow Leaving Site includes cistern/pipe flow, uncontrolled areas, and apartment rooftop runoff but excludes the undeveloped areas being routed around the site as these are left unchanged and do not impact the criteria. Note that the flow from cistern, roof, and uncontrolled may not match the total flow leaving the site as each peak occurs at a different time.

---

## 3.4 Water Quantity – Parcel 2

As noted in **Section 2.4**, the target allowable release rate to the municipal sewer along Cordillera Street during a 10-year storm provided no adverse impacts from major-system flows is 60.0 L/s. Compliance with this target discharge rate will be achieved through use of rooftop ponding on the apartment building with flow control drains, pipe storage, and the provision of an underground cistern storage structure. Flows directed to the future Canadian Shield Avenue (mostly undeveloped) will be routed through a ditch inlet catch basin and discharge to the future Canadian Shield Avenue. Major flows will be directed toward the major system.

Runoff rates and storage volumes for Parcel 2 were determined using the modelling software PCSWMM. Post-development runoff calculations have accounted for uncontrolled runoff from portions of the site that will not drain to storage features.

A significant portion of quantity control will be provided with the provision of an underground storage cistern and upstream pipe storage. This system will be designed to control runoff draining to Cordillera Street in the 10-year storm. The figure in **Appendix E** illustrates the controlled, uncontrolled, and undeveloped areas and further shows which areas are being directed to the future Canadian Shield Avenue and which areas are being directed to Cordillera Street. Uncontrolled runoff to Cordillera Street contributes to the total allowable release rate modelled. Storage was calculated using HydroCAD (**Appendix G**).

The cistern will discharge to Cordillera Street via gravity, and peak outflow rates will be controlled via an orifice control device. Sizing was completed iteratively using PCSWMM (**Appendix G**) and checked in Excel (**Appendix D**). To satisfy net target release rates for controlled and uncontrolled site areas, the recommended peak discharge rate for flow control device is 26.16 l/s (at HGL = Cistern Spill). A 150 mm diameter circular orifice has been specified to meet the target release rate. It is important to note that an “HGL = Top of Cistern” would represent a design event greater than the 100-year storm and that the return period associated with an overflow event requiring these facilities to spill would exceed 100-years.

The apartment building will provide its own stormwater detention through use of temporary surface ponding. It has been assumed that 77% of the apartment building rooftop will be available for ponding with 15 roof drains provided per AutoCAD roof plans provided by API Consultants on April 30, 2021. For modelling purposes, these outlets were simulated using rating curves for a *Watts Accutrol* product (in the “1/4

exposed” position, **Appendix F**). Controlled runoff from the roof is directed downstream of the cistern storage structure.

As mentioned above, flows from the proposed townhouses fronting onto Campeau Drive will be directed to the stormwater cistern instead of being released directly to Campeau Drive. Foundation drains will be connected to a secondary pipe system which will discharge downstream of system controls to protect foundations from backups in the cistern.

If a storm event that occurs fills the cistern, the downstream maintenance hole (Rim = 101.79m) would allow water to spill to the Cordillera Street major system. It is noted that the return period associated with an overflow event requiring these facilities to spill would exceed 10-years. Overflow for the 100-year event has been provided to the City of Ottawa for review against tolerable right of way flooding depth and velocities.

As per Site Servicing Plan Drawing discharge from the cistern is proposed to the Cordillera Street trunk storm sewer.

**Appendix E** illustrates the small portions of the project site that will drain offsite uncontrolled to Cordillera Street in post-development conditions. These uncontrolled runoff rates contribute to the total allowable release rate modelled. **Appendix E** also illustrates the areas draining to the future Canadian Shield Avenue.

A PCSWMM model of the project was constructed for Parcel 2 for its ability to provide detailed runoff hydrographs resulting from tested design storm distributions for use within the City’s model when checking critical major system flow depths and velocities. This model was utilized to include:

- storage and controlled release of stormwater from apartment rooftop areas on 77% of the rooftop area downstream of the cistern
- controlled runoff from at-grade areas directed to pipe storage + cistern
- controlled runoff from townhouse areas directed to pipe storage + cistern
- small areas of uncontrolled runoff rates generated from at grade areas constructed with soft and hard landscaping directed to Cordillera Street
- small areas of uncontrolled runoff rates generated from at grade areas constructed with soft and hard landscaping directed to the future Canadian Shield Avenue
- undeveloped areas directed to the future Canadian Shield Avenue

Flows rates generated from areas within the project site discharging to Cordillera Street remain below 60 L/s in the 10-year storm. Peak storage and peak discharge from the site to Cordillera Street both occurred under the 6-hour Chicago storm. Hydrographs showing peak discharge from the site to 1- Cordillera Major System, 2- Cordillera Minor System, and 3- Combined Discharge to the Future Canadian Shield Avenue under 3, 6,

and 24-hour Chicago Storms with 5, 10, and 100-year return periods have been provided to the City of Ottawa on May 13, 2021.

Modelling results are summarized below in **Table 3-2** and shown in **Appendix H**.

**Table 3-2: Summary of Modelling Results**

Return Period (Years)*	Utilized Cistern / Pipe / Roof Storage (m <sup>3</sup> )	Peak Water Elev. in Cistern (m)	Peak Flow to Canadian Shield Avenue (L/s)	Peak Cistern Flows (L/s)	Peak Roof Flows (L/s)	Peak Cistern Spill Flows (L/s)	Peak Cordillera St. Minor System Flows (L/s)	Peak Cordillera St. Major System Flows (L/s)	Peak Total Flow to Cordillera St.** (L/s)	Allowable 10-yr Flow Rate (L/s)
5	122.5 15.9 155.8	100.19	43.58	40.09	5.2	0	44.9	1.9	44.9	<b>60</b>
10	152.5 16.54 102.1	100.40	19.76	45.14	5.7	0	50.5	2.4	<b>51.3</b>	
100	217.8 17.17 85.57	101.81	14.49	74.37	7.0	236.8	80.3	65.0	14.5	

\*Critical Storm Duration = 24-hours for peak flow and storage requirements

\*\*Total Flow to Cordillera Street includes cistern/pipe flow, uncontrolled areas, and apartment rooftop runoff. Note that the flow from cistern, roof, and uncontrolled may not match the total flow leaving the site as each peak occurs at a different time.

## 4 CONCLUSIONS

A stormwater management plan has been prepared to support the site plan application for the 6301 Campeau Drive development in the City of Ottawa. The key points are summarized below.

### WATER QUANTITY FOR PARCEL 1

Controlled runoff collected from the project site will be directed to a stormwater cistern with a minimum active storage volume of 458.4 m<sup>3</sup> to control the 100-year event. Stormwater from the apartment roof top will be controlled using roof drains and discharged downstream of the cistern control. The peak 100-year discharge from the site excluding undeveloped areas routed around the site controls is 70.4 l/s using roof drains and the minimum recommended orifice diameter (122 mm), which is a slight exceedance to the 5-year pre-development flow rate of 70.3 l/s.

### WATER QUANTITY FOR PARCEL 2

Controlled runoff collected from the project site will be directed to a stormwater cistern with a minimum active storage volume of 220 m<sup>3</sup> to control the 10-year event and reduce overflow in the 100-year event. Stormwater from the apartment roof top will be controlled using roof drains and discharged downstream of the cistern control. The cistern will be controlled with a 150 mm orifice control. The peak 10-year discharge to Cordillera Street from the site excluding the undeveloped area draining through Parcel 1 and flows to the future Canadian Shield Avenue is 51.3 l/s which is below the peak allowable release rate of 60.0 l/s. Flows in excess of the 10-year storm will be directed as surface flows along Cordillera toward the Kanata Town Centre SWMF and are anticipated to be within tolerable flow depths and velocities to be confirmed with the City of Ottawa.

Runoff draining to the future Canadian Shield Avenue is largely undeveloped and will be controlled through a ditch inlet catch basin to the sewer along Canadian Shield Avenue once constructed. Flows in excess of the minor event will be directed to the major system and are expected to be within tolerable flow depths and velocities to be confirmed with the City of Ottawa.

### WATER QUALITY FOR PARCEL 1

If the build out of the adjacent Golf Course development south of Campeau Drive is carried out, treatment will be provided by a pond and OGS within the development. In the event that development does not proceed, an OGS will be provided at the downstream end of Parcel 1 to provide treatment to ensure an 80% TSS removal rate.

## WATER QUALITY FOR PARCEL 2

Water treatment is to be provided for as part of downstream systems and therefore, no specific water quality treatment features are required.

This report demonstrates that the proposed SWM strategy will address stormwater management related impacts from this project and meet the requirements of the City of Ottawa.

# APPENDIX

**A**

City Correspondence



# APPENDIX

## **A-1** Pre-consultation Meeting Minutes (November 8, 2019)

**Part of 6301 Campeau Drive**  
**Pre-Consultation Meeting Minutes**

Location: Room 4102E, City Hall  
Date: November 8, 2:00pm to 3:00pm

<b>Attendee</b>	<b>Role</b>	<b>Organization</b>
Mark Young	Planner	City of Ottawa
Justin Armstrong	Project Manager (Infrastructure)	
Neeti Paudel	Project Manager (Transportation)	
Matthew Hayley	Planner (Environment)	
Justyna Garbos	Planner (Parks)	
Matthew Ippersiel	Planner (Urban Design)	
Lauren Reeves	Owner	OCLDC
Sameer Gulamani	Applicant	Bayview Hospitality
Alnoor Gulamani	Applicant	Bayview Hospitality

**Comments from Applicant**

1. The applicant is proposing a phased development of purpose-built 6-storey multi-residential apartment buildings at the south side of the site and 3-storey townhouses on the north side of the site along Campeau Drive. The buildings would have shared covered podium parking in the middle of the site which will have amenity space on top. Access is provided through Cordillera street and through a laneway shared with the adjacent private retirement home (which may not be feasible).
2. A central access point or alternative access point for the western development block would be preferable.
3. Zoning By-law relief will be requested for the requirement for 50% at grade commercial development.

**Planning Comments**

1. The proposal will require a major Zoning By-law Amendment Application and a New complex site plan approval application.
2. Please ensure that all zoning requirements and provisions are indicated on the provided plans.
3. Commercial uses should be maintained as a permitted use at grade, but a stringent requirement for 50% should be revisited. Commercial viability at grade on Cordillera Street and Maritime Way.

4. A joint access for both parcels on Campeau Drive aligned with Stonecroft Terrace may be a viable option. This would also need to include accessible pedestrian access to the Town Centre Park.
5. Consideration for the opportunity for flexible units that could accommodate small businesses on Campeau Drive needs to be considered as part of the design and zoning.
6. The maximum permitted height is 3 storeys – therefore the basement level as proposed must be more than 50% below grade. We would recommend front to back ground floor suites, with accessible access to allow for home based business opportunities.
7. Zoning By-law amendment application will need to address portions of the site currently zoned Development Reserve (DR), proposed performance standards and the addition of townhouse as a permitted use.

### Urban Design Comments

1. Generally supportive of the proposed scale of the buildings and the urban treatment of Campeau.
2. The apartment building in the south-east corner of the site should be an L-shaped building, wrapping the corner of the site with a frontage on Cordillera Street. This may also be an appropriate location for ground floor retail.
3. The greening of the rooftops of the parking decks as amenity space is supported. The internal courtyard spaces would likely be even stronger places if they were entirely at grade level.
4. Consider the relationship that will be created between the townhomes and the parking garage, what the pedestrian experience will be in that space, and how the raised amenity space will be accessed from the north. Alternatively, connecting the raised parking structure directly to the buildings, as suggested, may be worth exploring as an option.
5. As the plan progresses, consider what the interface between the development and the park to the south will be. Try to establish a clear delineation between public and private space and ensure there are pedestrian connections through the site.
6. Consider relocating the east-west drive aisle to the south of the property, between the development and the park. This would improve the relationship with the park, clarify the distinction of public and private space, and may help connect the apartment buildings to the amenity space (as they would be shifted north).
7. The proposal will be subject to a formal review with the Urban Design Review Panel. An informal pre-consultation meeting with the panel is also recommended at an early stage in the development review process. The next meetings are scheduled for:
  - December 6<sup>th</sup> (Nov 22<sup>nd</sup> submission deadline)
  - January 10<sup>th</sup> (Dec 27<sup>th</sup> submission deadline)

- More details available on the UDRP [webpage](#). For questions, email UDRP coordinator David Maloney: [David.Maloney@ottawa.ca](mailto:David.Maloney@ottawa.ca)

### Parks Planning:

1. Parks will take cash-in-lieu of parkland at an amount equivalent to 10% of the value of the land area of the site being developed. The exact amount will be identified as a condition of site plan approval. In addition, the applicant will be charged a land appraisal fee of \$565 (HST included).
2. Bill Teron Park is planned to be expanded in the future. Please see the attached plan for illustration of the expansion. The applicant should be mindful of their development's transition to/connection into the future parkland south of it.
3. If a combined vehicular/pedestrian site access is considered on the intervening city parkland access block, Parks planning will play an active role in the detailed design of this access to ensure that pedestrian access to Bill Teron Park is prioritized, designed in accordance with the Parks Development Manual, and meets accessibility requirements. The construction of said vehicular and pedestrian access shall be solely at the cost of the developer, and shall not be credited toward cash-in-lieu of parkland requirements. Parks Planning is willing and wanting to work with the developer to help find solutions that benefit both parties.
4. All efforts shall be utilized to protect and retain city owned trees on the abutting city park land. The required TCR shall identify how these trees are being protected. The report shall also address any mitigation measures required for tree retention if blasting and associated grading is required adjacent to the park property line.
5. Efforts shall be undertaken to ensure that the grade differential between the park block and the development sites is minimized to the greatest extent possible.

### Engineering Comments

The following are engineering comments related to the recent pre-consultation meeting for the development of 6301 Campeau Drive that was held on Friday November 8<sup>th</sup>, 2019. It is recommended that the developer retain a local engineering firm familiar with the City of Ottawa's procedures and requirements in order to navigate the comments made below and provide recommendations pertaining to the potential engineering design for the proposed site.

#### 1. WATER

- Water is available along Campeau and along Cordillera/Canadian Shield.
- Watermain looping will be required for the proposed development.

- As per The City of Ottawa's Water Distribution Guidelines Technical Bulletin ISDTB-2014-02, individual residential facilities with a basic day demand greater than  $50\text{m}^3/\text{day}$  shall be connected with a minimum of two water services, separated by an isolation valve, to avoid the creation of a vulnerable service area.
- A watermain boundary condition request should be made for each proposed connection to the City watermain. As part of the request, anticipated domestic demands and FUS fireflow requirements should be provided along with a screenshot of the proposed connection locations. The request can be sent to [justin.armstrong@ottawa.ca](mailto:justin.armstrong@ottawa.ca).

## 2. SANITARY

- Sanitary is available along Campeau and along Cordillera/Canadian Shield. For discharge to either location, it should be demonstrated that capacity exists within the receiving sewers. The Servicing Brief (Revised) Kanata Town Centre Central Business District Subdivision Memo prepared by J.L.Richards for Urbandale Corporation, dated June 13, 2012 (attached), and the sanitary sewer design sheet prepared by J.L.Richards for Urbandale dated October 12, 2016 (attached) are related to the design of the sanitary sewers along Cordillera/Canadian shield. These documents should be consulted when demonstrating capacity exists for sewage discharging to this location.

## 6. STORM

- The report titled *Kanata Town Centre Phasing and Servicing Overview*, prepared by IBI Group, dated September 23, 2013 (attached) states that *"a 1200 mm diameter culvert under Campeau Drive at the Omnicare site and the storm sewer outlet for Omnicare were designed to outlet a portion of the Kanata Town Centre lands adjacent to Campeau Drive. This storm outlet is directly available to Block A to D inclusive. On-site attenuation to predevelopment flow should be considered a requirement for the purposes of advancing use of the storm outlet."* The referenced 1200 mm diameter culvert outlets under Campeau Drive to the existing Kanata Lakes Golf Course. This statement is consistent with the proposed Storm Servicing and Drainage Plan submitted by DSEL as part of the proposed Kanata Lakes Golf Course development application (D07-16-19-0026), in which a 3.32 ha drainage area (runoff coefficient = 0.2) located south of Campeau Drive has been proposed for allocation to drain to the golf course lands. The proposed Kanata Lakes Golf Course development application files can be obtained from the following link:  
<https://app01.ottawa.ca/postingplans/appDetails.jsf?lang=en&appld= BONQQQ>

Please keep in mind that providing onsite attenuation to restrict the storm release rate to predevelopment flows will require significant onsite storage (given that the site is currently grassed/landscaped).

- IBI's report, noted above, also states that *"A local storm sewer varying in size from 525mm diameter to 1650 mm diameter exists in Kanata Main Street and Canadian Shield Avenue across the full frontage of the Kanata Town Centre site. This storm sewer has limited capacity available for direct connection from the Town Centre development, with the understanding that onsite attenuation will be required to match the sewer design capacity as specified in MOE Certificate of Approval Number 3-1378-98-006."* The above-mentioned sewers ultimately outlet to Urbandale's stormwater management pond located at the south-east corner of the Town Centre lands. The SWM pond was designed in accordance with the report titled *Stormwater Management Report, Kanata Town Centre, Central Business District*, prepared by J.L. Richards, dated January 1999 (attached). JLR's report is consistent with IBI's report in which Blocks E, G, H, I and J have been allocated to the existing storm sewers within Kanata Main Street and Canadian Shield Avenue with an outlet to Urbandale's pond. The allocated release rate for each parcel of land will be restricted to the sewer design capacity of the storm sewers as well as the stormwater allocations set with JLR's report.
- 

If servicing allows it, there may be an opportunity to re-direct storm flows from Block A through D to outlet to Canadian Shield Avenue and ultimately Urbandale's pond if it can be demonstrated that the storm sewers and stormwater management pond have capacity to accept the additional flows.

#### Transportation Planning:

1. Follow Traffic Impact Assessment Guidelines
  - Scoping form should be submitted– triggers trip generation. Meets the triggers for full Traffic Impact Assessment.
  - Applicant advised that their application will not be deemed complete until the submission of the draft step 1-4, including the functional draft RMA package (if applicable) and/or monitoring report (if applicable).
  - Request base mapping asap if RMA is required. Contact Engineering Services (<https://ottawa.ca/en/city-hall/planning-and-development/engineering-services>)
  - All requested access locations including the access between the two parcels on Campeau Drive (if proposed) will be reviewed at the TIA strategy (analysis) stage.
2. ROW protection on Campeau Drive between Didsbury and Teron is 40m even. Ensure that this is protected. Campeau Drive at this section is identified to be widened in the 2031 network concept of the TMP (Terry Fox to March) and no parking is currently proposed on Campeau. An eyebrow Street within the right of way is not supported as a temporary measure. Please note that if and when the EA for the widening of Campeau Drive is updated on-street parking may be considered.

3. Site triangles at the following locations on the final plan will be required:
  - Arterial Road to Local Road: 5 metre x 5 metres
4. Noise Impact Studies required:
  - Road
5. On site plan:
  - Show all details of the roads abutting the site up to and including the opposite curb; include such items as pavement markings, accesses and/or sidewalks.
  - Turning templates will be required for all accesses showing the largest vehicle to access the site; required for internal movements and at all access (entering and exiting and going in both directions).
  - Show all curb radii measurements; ensure that all curb radii are reduced as much as possible
  - Show lane/aisle widths.
  - Sidewalk is to be continuous across access as per City Specification 7.1.

Planning Forester:

1. A Tree Conservation Report (TCR) must be supplied for review along with the suite of other plans/reports required by the City;
2. Tree removal
  - a. any removal of privately-owned trees 10cm or larger in diameter requires a tree permit issued under the Urban Tree Conservation Bylaw; the permit is based on the approved TCR
  - b. any removal of City-owned trees will require the permission of Forestry Services who will also review the submitted TCR
3. The TCR must list all trees on site by species, diameter and health condition – separate stands of trees may be combined using averages
4. The TCR must clearly show where tree removal will occur.
5. Tree permits for geotechnical work are possible, but tree removal must be limited to areas required for machinery access and drilling; please provide a plan supported by the TCR showing travel routes and landings
6. All retained trees must be shown and all retained trees within the area impacted by the development process must be protected as per City guidelines listed on Ottawa.ca
7. For more information on the process or help with tree retention options, contact Mark Richardson [mark.richardson@ottawa.ca](mailto:mark.richardson@ottawa.ca)

Environment:

1. An EIS/TCR is required to address species at risk.
2. They will also need to address the Protocol for Wildlife protection during Construction which is available at [www.ottawa.ca](http://www.ottawa.ca)

### Requested Plans and Studies

1. A list of required plans and studies required for a complete Site Plan Control application have been attached.

### Process

1. This is a pre-consultation for a Zoning By-law Amendment and Site Plan Control application at 6301 Campeau Drive to the requirements for a complete application.
2. This proposal will trigger a Major Zoning By-law Amendment Application and a New Site Plan Control application, Manager Approval, subject to Public Consultation. The proposal would fall under the 'complex' category as per the [Site Plan Control Subtype Thresholds](#). The application form, timeline and fees can be found [here](#).

Please refer to the links to "[Guide to preparing studies and plans](#)" and [fees](#) for general information. Additional information is available related to [building permits, development charges, and the Accessibility Design Standards](#). Be aware that other fees and permits may be required, outside of the development review process. You may obtain background drawings by contacting [informationcentre@ottawa.ca](mailto:informationcentre@ottawa.ca).

These pre-con comments are valid for one year. If you submit a development application(s) after this time, you may be required to meet for another pre-consultation meeting and/or the submission requirements may change. You are as well encouraged to contact us for a follow-up meeting if the plan/concept will be further refined.

Please contact me at [Mark.Young@ottawa.ca](mailto:Mark.Young@ottawa.ca) or at 613-580-2424 extension 41396 if you have any questions.

Sincerely,



Mark Young MCIP RPP  
Planner III  
Development Review - West



# APPENDIX

## **A-2** E-mail Correspondence (April 8, 2021)

## Stewart, Michael

---

**From:** Yang, Winston  
**Sent:** April 12, 2021 1:55 PM  
**To:** Dennis Jacobs  
**Cc:** Hughes, Michelle; Girard, Louis-Marc; Jafferjee, Ishaque; Stewart, Michael  
**Subject:** FW: 6301 and 6475 Campeau First Round of Comments

Hi Dennis,

We have received some feedback from the City last week. Please see email below for the city direction regarding the SWM design criteria. Our team will look into it this week and will let you know the status later this week.

Yours truly,

**Ding Bang (Winston) Yang, P.Eng.**

Project Engineer  
Infrastructure



T+ 1 613-690-0538

2611 Queensview Drive, Suite 300  
Ottawa, Ontario,  
K2B 8K2, Canada

[www.wsp.com](http://www.wsp.com)

---

**From:** Armstrong, Justin <justin.armstrong@ottawa.ca>  
**Sent:** April 8, 2021 5:04 PM  
**To:** Yang, Winston <Winston.Yang@wsp.com>  
**Cc:** Stewart, Michael <michael.stewart@wsp.com>; Jafferjee, Ishaque <Ishaque.Jafferjee@wsp.com>; Hughes, Michelle <Michelle.Hughes@wsp.com>  
**Subject:** RE: 6301 and 6475 Campeau First Round of Comments

Hi Winston,

I have heard back from our Water Resources Engineer in regard to the Parcel 2 comment below and he has indicated the following:

The JLR table WSP used in determining the stormwater storage requirements for the site was used in JLR's report as a conservative pond sizing exercise for sizing the SWM pond and was not intended to indicate post-development stormwater storage requirements for each contributing parcel. The JLR report can be used to determine the allowable release rate to the storm sewer but should not be used in determining on-site storage requirements. The City's SWM guidelines are in place to protect private adjacent owners and to ensure that flooding does not occur at the street level and these guidelines will need to be enforced here. That being said, given the fact that the existing JLR report caused some confusion, and that there are some on-site topographical constraints, we may be flexible. Unfortunately, the sewer in Cordillera was only designed to receive a small portion of Parcel 2 runoff so there is not much residual capacity

in the sewer, however, we have had a look at the City's storm sewer model and there does seem to be some available capacity in the Cordillera sewer to increase the total allowable release rate for Parcel 2 from the 39.1L/s proposed by WSP to 60L/s. Please apply the new release rate of 60L/s to the site and provide additional on-site storage as required to store up to the post-development 100-yr on site. After applying the new release rate and providing as much additional storage as is feasible, indicate the following:

- Where does the excess flow (up to 100 year) spill. If it spills onto adjacent lands, then it would be completely unacceptable because the future developer of the adjacent lands would need to account for this flow in their SWM analysis. A development cannot impose its flows onto an adjacent landowner.
- If the flow spills to the City ROW (i.e. the street), then what is the impact on the street? At the time (1996), we did not look at depth of flow on streets but today this has become a big issue. Now, if we are only talking about a small peak flow, then it may be negligible, but I would need to know how much 100-year flow is spilling to the street if it does. The excess flow from the property would then make its way to the pond via the streets and we would want to make sure that it does not cause flooding along the way (if the flow is significant). Unfortunately, we cannot do this assessment ourselves at this time due to existing workload issues and we would only be able to get to it late in the year. WSP would therefore have to undertake this analysis themselves for the flow path from the site to the pond (if they are spilling to the street) and we would need to review. Due to our workload issues this would still take some time but would be quicker than if we performed the analysis ourselves.

To summarize, the allowable release rate from the site can be increased from 39L/s to 60L/s. Additional on-site storage up to the 100-year to be provided. No flow up to the 100-year storm will be allowed to spill on any adjacent lands. If spilling to the street, then how much is it and what is the impact on the street system?

Let me know if there are any questions. Once the points above have been implemented, provide a response to me and I can continue to coordinate with our Water Resources group. Hopefully, the increased release rate can lessen the on-site storage burden and enough additional on-site storage can be provided.

Regards,

Justin

---

**From:** Yang, Winston <[Winston.Yang@wsp.com](mailto:Winston.Yang@wsp.com)>

**Sent:** March 31, 2021 5:01 PM

**To:** Armstrong, Justin <[justin.armstrong@ottawa.ca](mailto:justin.armstrong@ottawa.ca)>

**Cc:** Stewart, Michael <[michael.stewart@wsp.com](mailto:michael.stewart@wsp.com)>; Jafferjee, Ishaque <[ishaque.jafferjee@wsp.com](mailto:ishaque.jafferjee@wsp.com)>; Hughes, Michelle <[Michelle.Hughes@wsp.com](mailto:Michelle.Hughes@wsp.com)>

**Subject:** RE: 6301 and 6475 Campeau First Round of Comments

Hi Justin,

Understood. Thanks for looking into the concerns.  
Hope we can sort things out after the meeting.

Thanks,

**Ding Bang (Winston) Yang, P.Eng.**

Project Engineer

Infrastructure



T+ 1 613-690-0538

2611 Queensview Drive, Suite 300  
Ottawa, Ontario,  
K2B 8K2, Canada

[www.wsp.com](http://www.wsp.com)

---

**From:** Armstrong, Justin <[justin.armstrong@ottawa.ca](mailto:justin.armstrong@ottawa.ca)>  
**Sent:** March 31, 2021 4:54 PM  
**To:** Yang, Winston <[Winston.Yang@wsp.com](mailto:Winston.Yang@wsp.com)>  
**Cc:** Stewart, Michael <[michael.stewart@wsp.com](mailto:michael.stewart@wsp.com)>; Jafferjee, Ishaque <[Ishaque.Jafferjee@wsp.com](mailto:Ishaque.Jafferjee@wsp.com)>; Hughes, Michelle <[Michelle.Hughes@wsp.com](mailto:Michelle.Hughes@wsp.com)>  
**Subject:** RE: 6301 and 6475 Campeau First Round of Comments

Hi Winston,

In terms of the Parcel 1 comments below and in the first round of comments, they are in line with what was requested in the pre-consultation meeting. The pre-consultation notes indicate, *“On-site attenuation to predevelopment flow should be considered a requirement for the purposes of advancing use of the storm outlet”*. This requirement does not change whether the Club Link subdivision moves forward or not and has not changed as a result of any comments. The pre-consultation notes do not specifically mention quality control, however, it is standard that the quality control for any given site-plan must meet the Conservation Authority’s requirement. The future of the Club Link subdivision was never a certainty, as the application has been contested by the City since its inception. Club Link has appealed the judge’s decision to prevent the subdivision from moving forward, but this does not change the fact that, as of this moment, the subdivision development is not moving forward and so Parcel 1 cannot rely on it for its SWM design.

I have discussed Michael’s request related to the Parcel 2 comment (attached) with the Senior Engineer in our Water Resources Unit. He is looking into the viability of the request and is going to get back to me. Following his response, I will reach out and I can organize a meeting.

Have a great evening,

Justin

During this period of uncertainty surrounding COVID-19, we are following best practices recommended to minimize the risk of exposure, while ensuring that service to our clients remains as uninterrupted as possible. For the most part I am working from home and will respond to emails at my earliest opportunity. Should there be delays due to internet connectivity, I thank your understanding and patience.

**Justin Armstrong, E.I.T.**

Engineering Intern

Planning, Infrastructure and Economic Development Department - Services de la planification, de l’infrastructure et du développement économique

Development Review - West Branch

City of Ottawa | Ville d’Ottawa

110 Laurier Avenue West Ottawa, ON | 110, avenue. Laurier Ouest. Ottawa (Ontario) K1P 1J1

613.580.2400 ext./poste 21746, [justin.armstrong@ottawa.ca](mailto:justin.armstrong@ottawa.ca)

---

**From:** Yang, Winston <[Winston.Yang@wsp.com](mailto:Winston.Yang@wsp.com)>  
**Sent:** March 31, 2021 3:22 PM  
**To:** Armstrong, Justin <[justin.armstrong@ottawa.ca](mailto:justin.armstrong@ottawa.ca)>  
**Cc:** Stewart, Michael <[michael.stewart@wsp.com](mailto:michael.stewart@wsp.com)>; Jafferjee, Ishaque <[ishaque.jafferjee@wsp.com](mailto:ishaque.jafferjee@wsp.com)>; Hughes, Michelle <[Michelle.Hughes@wsp.com](mailto:Michelle.Hughes@wsp.com)>  
**Subject:** RE: 6301 and 6475 Campeau First Round of Comments

Hi Justin,

Due to the dramatic changes in SWM design criteria that are completely different than what have already been set in the pre-consultation meeting.

We would like to go over the new design criteria and the associated comments with you and the reviewer from SWM sector prior to the next submission.

Could you help to setup a team meeting next week?

Thanks,

**Ding Bang (Winston) Yang, P.Eng.**  
Project Engineer  
Infrastructure



T+ 1 613-690-0538

2611 Queensview Drive, Suite 300  
Ottawa, Ontario,  
K2B 8K2, Canada

[www.wsp.com](http://www.wsp.com)

---

**From:** Armstrong, Justin <[justin.armstrong@ottawa.ca](mailto:justin.armstrong@ottawa.ca)>  
**Sent:** March 24, 2021 4:13 PM  
**To:** Yang, Winston <[Winston.Yang@wsp.com](mailto:Winston.Yang@wsp.com)>  
**Subject:** RE: 6301 and 6475 Campeau First Round of Comments

Good afternoon Winston,

See below for a few additional comments related to the 6301 Campeau Parcel 1 Development as it relates to its stormwater discharge location of the Kanata Lakes Golf Club lands. I just wanted to make sure a couple of the comments I had made in the attached are clear, as well as to pass on a couple additional comments so that they can be addressed with your second submission. Please be sure to consider the following for your second submission:

- As indicated in Comments B4 and B16 of the attached, the stormwater design for Parcel 1 should be considered under two scenarios (1 - If the Kanata Lakes Golf Club remains as is; 2 – If the subdivision moves forward on ClubLink lands). The stormwater design for Parcel 1 should not be presented in the servicing and SWM reports as relying on the redevelopment of the ClubLink lands in order to support the Parcel 1 development. Rather, the Servicing and SWM Reports should be written to present the SWM design under both possibilities listed above.

Since the more conservative of the two scenarios would be if the golf course remains as is, the reports and plans should err on the side of caution and present the stormwater design for Parcel 1 as if the golf course is to remain as is. A key factor that should be discussed in the reports and shown on the drawings is water treatment/water quality. On-site water quality control for Parcel 1 should be provided to MVCA's satisfaction, and this should be presented in both the reports and plans.

- The following statement is made in Section 4.2 of the Servicing Report, "For Parcel 1, the DSEL and J.F.Sabourin and Associates' SWM Pond Sizing for the Proposed Redevelopment of Kanata Golf And Country Club indicates that the present contributing area to the 750mm diameter storm sewer on the Campeau Drive is 3.22 ha, comprised of entirely impervious area." It seems that stating that the 3.22 ha is entirely impervious is a typo, as the entire 3.22 ha is currently undeveloped. Was it meant to say pervious instead of impervious? Please correct this for the second submission.
- Ensure that the most recent Kanata Lakes Golf Course Development Application plans and reports are consulted for your second submission and ensure that *Section 1.4 – Design Criteria* of the Stormwater Management report is updated accordingly. Currently, Section 1.4 indicates the following plans were consulted, "Kanata Lakes Golf Course Development Application: Stormwater Management Technical Memo, JFSA Water Resources and Environmental Consultants (September 20, 2019) and Storm Servicing and Drainage Plan, DSEL Engineering Ltd. (August 2019)". There are more recent plans and reports available and can again be accessed at the following link: <https://app01.ottawa.ca/postingplans/appDetails.jsf?lang=en&apld= BONQGO>.

Apologies again for continuing to pass on additional comments, but I just want to pass them on to you so that you have a chance to address them before your second submission. As always, give me a call if you would like to discuss.

Justin

---

**From:** Armstrong, Justin  
**Sent:** March 17, 2021 10:18 AM  
**To:** Yang, Winston <[Winston.Yang@wsp.com](mailto:Winston.Yang@wsp.com)>  
**Subject:** FW: 6301 and 6475 Campeau First Round of Comments

Good morning Winston,

I was informed by our Senior Engineer in our Water Resources Unit yesterday that the storage requirements outlined in the JLR tables you included in Appendix B-3 of the 6301 Campeau Report are no longer valid as JLR's report is an old pre-amalgamation and pre-City guidelines report. As such, the City's current guidelines govern the storage requirement for parcel 2. The allowable release to the sewer in Cordillera can still use the C-value provided in the report for Area 14 (i.e. 0.85), however flows in excess of the allowable release rate will need to be stored on site up to the 100-yr. The highlighted portion of engineering comment B21 in the attached should be replaced with the following: *Furthermore, flows in excess of the allowable release rate are to be stored on-site up until the 100-year storm. Please demonstrate that adequate on-site storage is being proposed to meet this requirement.*

Apologies for not including this with the comments that were sent out on Thursday. Please apply this comment to the redesign of parcel 2. Feel free to give me a call at my extension (21746) if you would like to discuss.

Regards,

Justin

During this period of uncertainty surrounding COVID-19, we are following best practices recommended to minimize the risk of exposure, while ensuring that service to our clients remains as uninterrupted as possible. For the most part I am

working from home and will respond to emails at my earliest opportunity. Should there be delays due to internet connectivity, I thank your understanding and patience.

**Justin Armstrong, E.I.T.**

Engineering Intern

Planning, Infrastructure and Economic Development Department - Services de la planification, de l'infrastructure et du développement économique

Development Review - West Branch

City of Ottawa | Ville d'Ottawa

110 Laurier Avenue West Ottawa, ON | 110, avenue. Laurier Ouest. Ottawa (Ontario) K1P 1J1

613.580.2400 ext./poste 21746, [justin.armstrong@ottawa.ca](mailto:justin.armstrong@ottawa.ca)

---

**From:** Dennis Jacobs <[djacobs@momentumplancom.ca](mailto:djacobs@momentumplancom.ca)>

**Sent:** March 11, 2021 10:21 AM

**To:** Shen, Stream <[Stream.Shen@ottawa.ca](mailto:Stream.Shen@ottawa.ca)>

**Cc:** Sameer Gulamani <[sameer.gulamani@bayviewhospitality.com](mailto:sameer.gulamani@bayviewhospitality.com)>; Paudel, Neeti <[neeti.paudel@ottawa.ca](mailto:neeti.paudel@ottawa.ca)>; Armstrong, Justin <[justin.armstrong@ottawa.ca](mailto:justin.armstrong@ottawa.ca)>

**Subject:** RE: 6301 and 6475 Campeau First Round of Comments

Thanks Shen.

We'll review this with the team and let you know if we have any follow up questions or clarifications as we prepare the response.

Dennis Jacobs

---

**From:** Shen, Stream <[Stream.Shen@ottawa.ca](mailto:Stream.Shen@ottawa.ca)>

**Sent:** March 11, 2021 8:51 AM

**To:** Dennis Jacobs <[djacobs@momentumplancom.ca](mailto:djacobs@momentumplancom.ca)>

**Cc:** Sameer Gulamani <[sameer.gulamani@bayviewhospitality.com](mailto:sameer.gulamani@bayviewhospitality.com)>; Paudel, Neeti <[neeti.paudel@ottawa.ca](mailto:neeti.paudel@ottawa.ca)>; Armstrong, Justin <[justin.armstrong@ottawa.ca](mailto:justin.armstrong@ottawa.ca)>

**Subject:** 6301 and 6475 Campeau First Round of Comments

Hi Dennis,

Please find attached the 1<sup>st</sup> round of comments for 6301 and 6475 Campeau OPA, ZBLA and Site Plan applications. We are available to meet to discuss as required.

Regards,

**Stream Shen MCIP RPP**

Planner II | Urbaniste II

Development Review | Examen des projets d'aménagement

110 Laurier Avenue West, 4<sup>th</sup> Floor

Ottawa, ON K1P 1J1

613.580.2424 ext. 24488

[stream.shen@ottawa.ca](mailto:stream.shen@ottawa.ca)

This e-mail originates from the City of Ottawa e-mail system. Any distribution, use or copying of this e-mail or the information it contains by other than the intended recipient(s) is unauthorized. Thank you.

Le présent courriel a été expédié par le système de courriels de la Ville d'Ottawa. Toute distribution, utilisation ou reproduction du courriel ou des renseignements qui s'y trouvent par une personne autre que son destinataire prévu est interdite. Je vous remercie de votre collaboration.

,  
,

This e-mail originates from the City of Ottawa e-mail system. Any distribution, use or copying of this e-mail or the information it contains by other than the intended recipient(s) is unauthorized. Thank you.

Le présent courriel a été expédié par le système de courriels de la Ville d'Ottawa. Toute distribution, utilisation ou reproduction du courriel ou des renseignements qui s'y trouvent par une personne autre que son destinataire prévu est interdite. Je vous remercie de votre collaboration.

,

---

NOTICE: This communication and any attachments ("this message") may contain information which is privileged, confidential, proprietary or otherwise subject to restricted disclosure under applicable law. This message is for the sole use of the intended recipient(s). Any unauthorized use, disclosure, viewing, copying, alteration, dissemination or distribution of, or reliance on, this message is strictly prohibited. If you have received this message in error, or you are not an authorized or intended recipient, please notify the sender immediately by replying to this message, delete this message and all copies from your e-mail system and destroy any printed copies. You are receiving this communication because you are listed as a current WSP contact. Should you have any questions regarding WSP's electronic communications policy, please consult our Anti-Spam Commitment at [www.wsp.com/cas](http://www.wsp.com/cas). For any concern or if you believe you should not be receiving this message, please forward this message to [caslcompliance@wsp.com](mailto:caslcompliance@wsp.com) so that we can promptly address your request. Note that not all messages sent by WSP qualify as commercial electronic messages.

AVIS : Ce message, incluant tout fichier l'accompagnant (« le message »), peut contenir des renseignements ou de l'information privilégiés, confidentiels, propriétaires ou à divulgation restreinte en vertu de la loi. Ce message est destiné à l'usage exclusif du/des destinataire(s) voulu(s). Toute utilisation non permise, divulgation, lecture, reproduction, modification, diffusion ou distribution est interdite. Si vous avez reçu ce message par erreur, ou que vous n'êtes pas un destinataire autorisé ou voulu, veuillez en aviser l'expéditeur immédiatement et détruire le message et toute copie électronique ou imprimée. Vous recevez cette communication car vous faites partie des contacts de WSP. Si vous avez des questions concernant la politique de communications électroniques de WSP, veuillez consulter notre Engagement anti-pourriel au [www.wsp.com/lcap](http://www.wsp.com/lcap). Pour toute question ou si vous croyez que vous ne devriez pas recevoir ce message, prière de le transférer au [conformitelcap@wsp.com](mailto:conformitelcap@wsp.com) afin que nous puissions rapidement traiter votre demande. Notez que ce ne sont pas tous les messages transmis par WSP qui constituent des messages électroniques commerciaux.

-LAEmlHhHzdJz8ITWfa4Hgs7pbKl

,

This e-mail originates from the City of Ottawa e-mail system. Any distribution, use or copying of this e-mail or the information it contains by other than the intended recipient(s) is unauthorized. Thank you.

Le présent courriel a été expédié par le système de courriels de la Ville d'Ottawa. Toute distribution, utilisation ou reproduction du courriel ou des renseignements qui s'y trouvent par une personne autre que son destinataire prévu est interdite. Je vous remercie de votre collaboration.

,  
,

This e-mail originates from the City of Ottawa e-mail system. Any distribution, use or copying of this e-mail or the information it contains by other than the intended recipient(s) is unauthorized. Thank you.



# APPENDIX

**B**

Relevant excerpts from  
background studies and reports

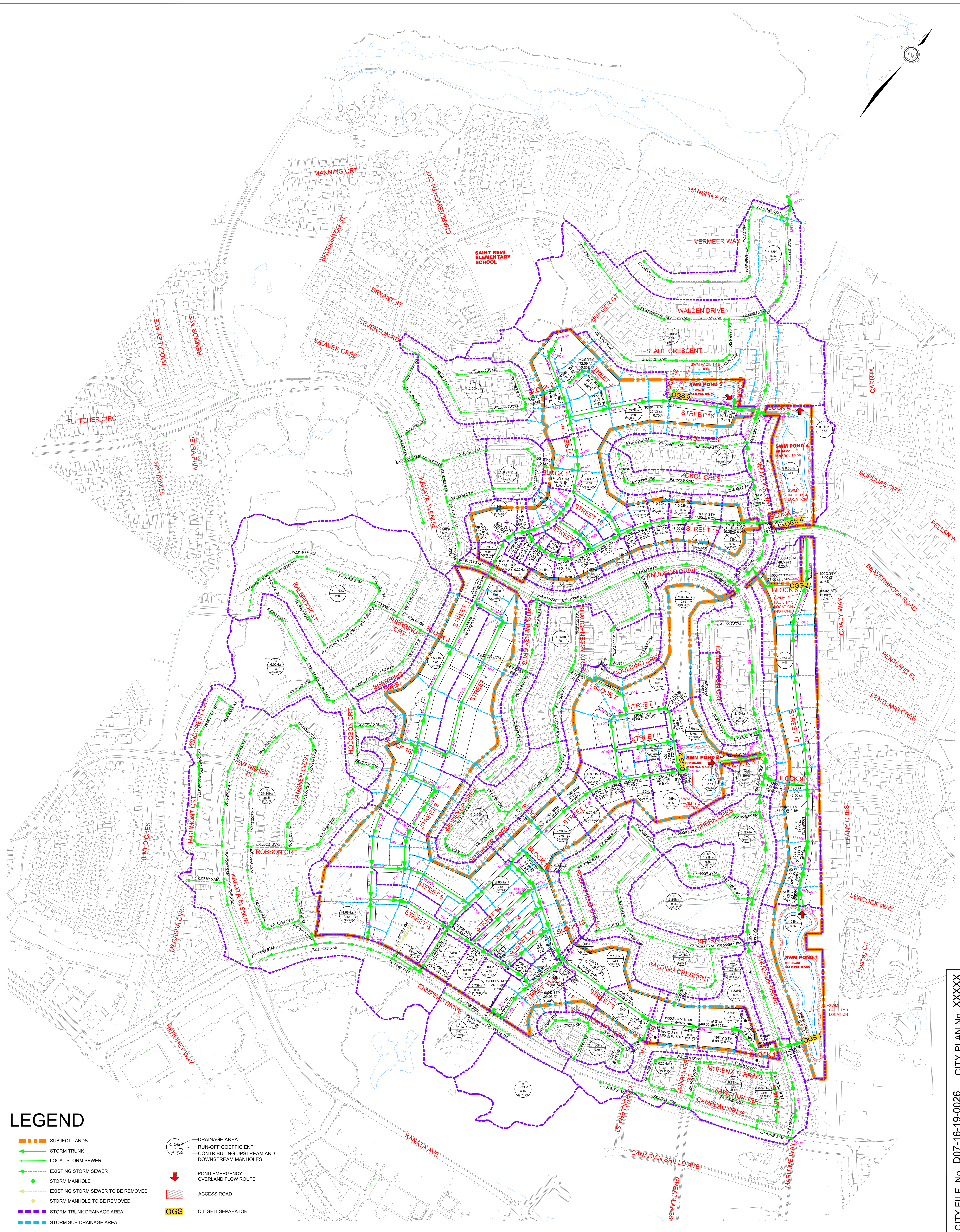
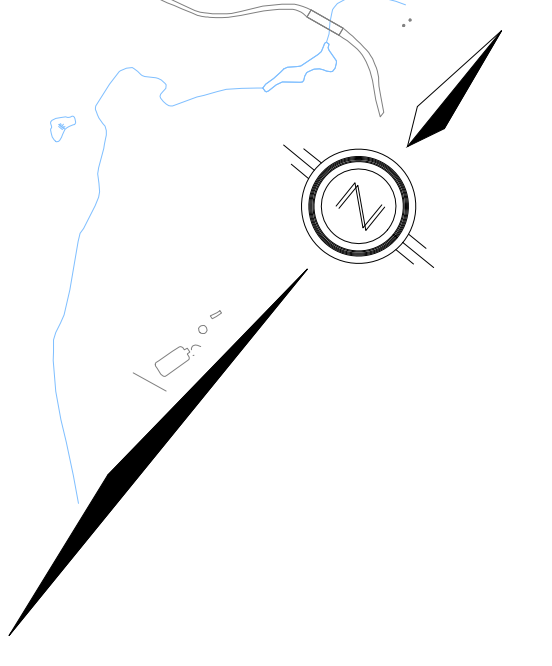

**LEGEND**

- SUBJECT LANDS
- STORM TRUNK
- LOCAL STORM SEWER
- EXISTING STORM SEWER
- STORM MANHOLE
- EXISTING STORM SEWER TO BE REMOVED
- STORM MANHOLE TO BE REMOVED
- STORM TRUNK DRAINAGE AREA
- STORM SUB-DRAINAGE AREA
- DRAINAGE AREA RUNOFF COEFFICIENT CONTRIBUTING UPSTREAM AND DOWNSTREAM MANHOLES
- POND EMERGENCY OVERLAND FLOW ROUTE
- ACCESS ROAD
- OIL GRIT SEPARATOR



120 Iber Road, Unit 103  
 Stittsville, Ontario, K2S 1E9  
 Tel. (613) 836-0856  
 Fax. (613) 836-7183  
 www.DSEL.ca

**7000 CAMPEAU DRIVE**  
**CITY OF OTTAWA**

**STORM SERVICING AND DRAINAGE PLAN**

SCALE:	1:2500	PROJECT No.:	1061
DATE:	MAY 2020	DRAWING No.:	03D

CITY FILE No. D07-16-19-0026 CITY PLAN No. XXXXX

# APPENDIX

## **B-2** Stormwater Catchments Draining to Kanata Town Centre SWMF

Excerpt from *Stormwater Management Report, Kanata Town Centre,  
Central Business District* by J.L. Richards & Associates Limited (January  
1999)

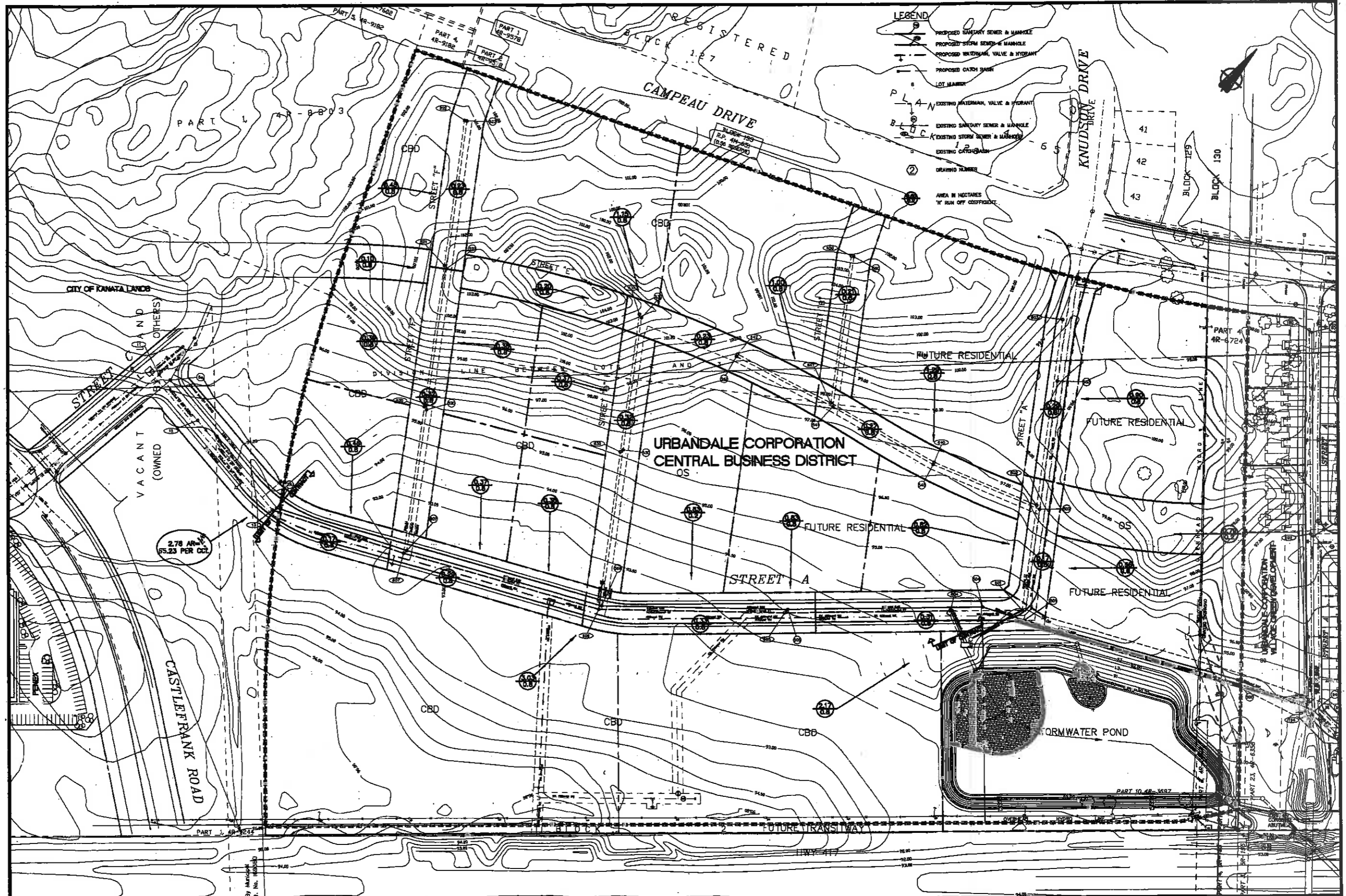

DATE	REVISIONS	BY	NO.	DATE	REVISIONS	BY
			2	05/11/98	REVISED PER RMOC	MFS
			1	09/10/98	ISSUED FOR MOE APPROVAL (ST&M)	MFS

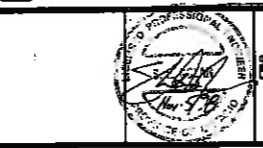

SCALE  
 HORIZONTAL 1:1000

**J.L. Richards & Associates Limited**  
 Consulting Engineers, Architect & Planners  
 OTTAWA, KINGSTON, SUDBURY, CANADA.

DESIGN S.D.  
 CHECKED M.F.S.  
 DRAWN T.S.  
 CHECKED  
 APPROVED

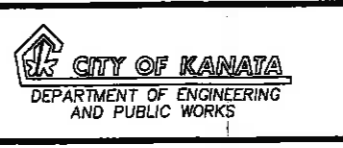

URBANDALE CORPORATION  
 KANATA TOWN CENTRE  
 CENTRAL BUSINESS DISTRICT  
 STORM DRAINAGE PLAN

DATED JUNE 1998  
 DWG. No. 15712-STM

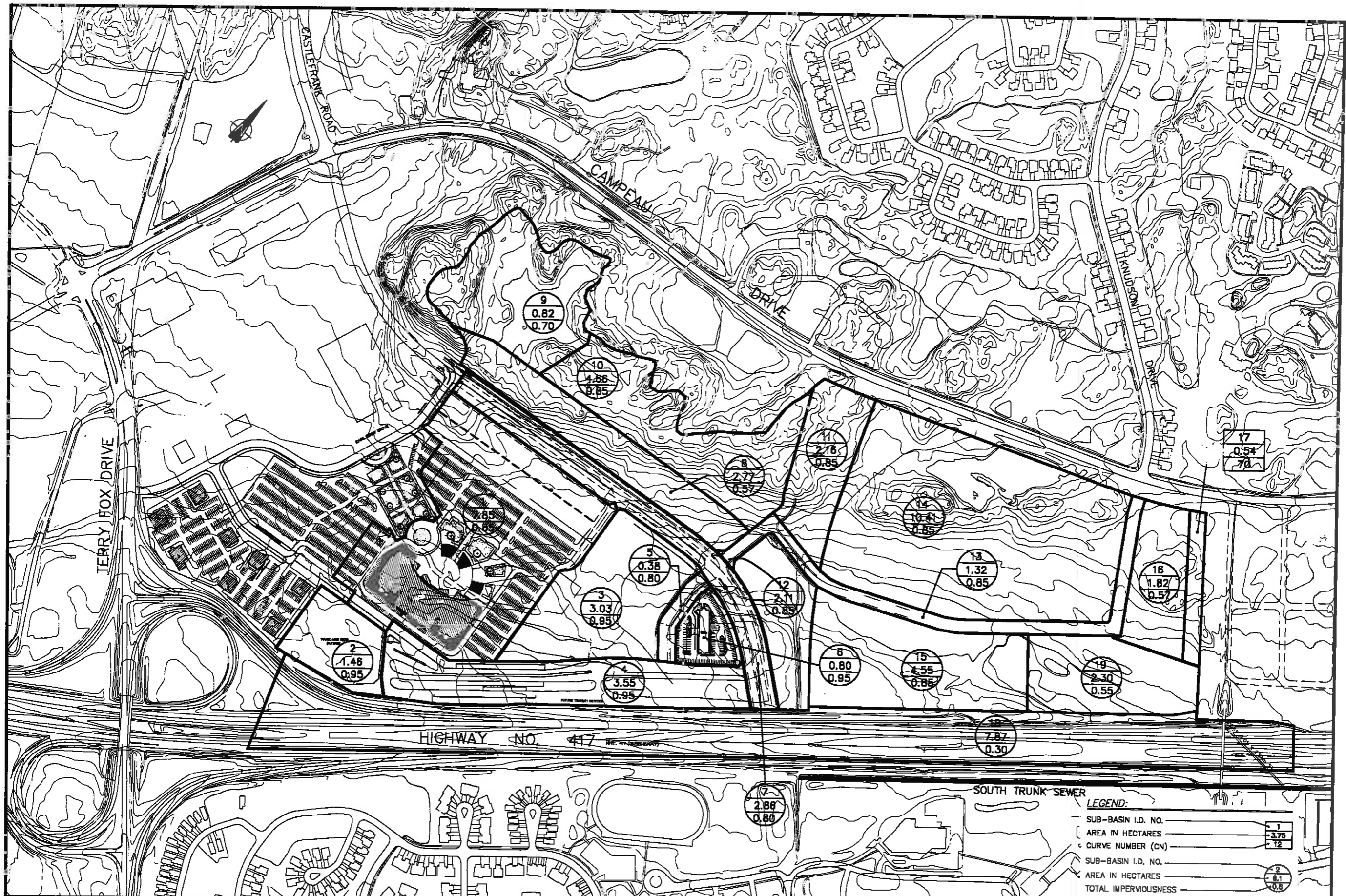

NO.	DATE	REVISIONS	BY	NO.	DATE	REVISIONS	BY

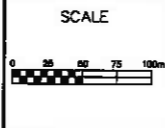

**J.L. Richards & Associates Limited**  
 Consulting Engineers, Architect & Planners  
 OTTAWA, KINGSTON, SUDBURY, CANADA.

DESIGN G.F.  
 CHECKED G.F.  
 DRAWN T.K.O'B.  
 DIGNED  
 APPROVED

**CITY OF KANATA**  
 DEPARTMENT OF ENGINEERING  
 AND PUBLIC WORKS

**URBANDALE CORPORATION**

**KANATA TOWN CENTRE  
 FUTURE CONDITIONS**

DATE: JANUARY 1988  
 DWG. NO.  
**FIGURE 3**

# APPENDIX

## **B-3** Minor System Capacity for Lands Draining to Kanata Town Centre SWMF

Excerpt from *Stormwater Management Report, Kanata Town Centre,  
Central Business District* by J.L. Richards & Associates Limited (January  
1999)

JLR 15712  
 Kanata Town Centre - Central Business District  
 Tributary Subwatersheds to Proposed Stormwater Management Facility

QUALHYMO LUMPED AREA No.	OTTHYMO AREA No.	Description	Area (ha)	TIMP	On-Site Storage	Description of Storage	IMP areas (ha)
1	1	AMC Site	7.85	0.85	entirely *	up to 100 yr	6.67
	2	Park & Ride	1.46	0.95	none		1.39
	3	Phase IV	3.03	0.95	entirely	up to 100 yr	2.88
	4	Transitway	3.55	0.95	none		3.37
	5	Hotel Road	0.38	0.80	none		0.30
	6	Hotel Site	0.80	0.95	entirely	up to 100 yr	0.76
2	7	Castlefrank Road	2.84	0.80	none		2.27
	8	Adjacent Lands	2.77	0.57	none		1.58
	9	Exist Pond **	0.82	---	entirely	up to 100 yr	0.00
	10	Kanata North	4.66	0.85	none		3.96
	11	Adj Lands (east)	2.16	0.85	none		1.84
	12	Adj Lands (south-east)	2.11	0.85	entirely	up to 100 yr	1.79
3	13	Street "A"	1.32	0.85	Limited	up to 10 yr	1.12
	14	Urbandale North	10.41	0.85	Limited	up to 10 yr	8.85
	15	Urbandale South	4.48	0.85	entirely	up to 100 yr	3.81
	16	Urbandale East	1.82	0.57	Limited	up to 10 yr	1.04
	17	Urbandale East (park)	0.54	---	none		0.00
	18	Queensway	7.87	0.30	none		2.36
	19A	SWMF	0.95	0.99	none		0.94
	19B	SWMF	1.42	0.20	none		0.28
		TOTAL	61.24				45.22
						Avg. TIMP =	0.74

\*: Overflow of 13 l/s @ 1:100 year storm event

\*\*\*: Peak flows from this area is to be restricted to 10 year based on Rc=0.2 (from CCL)

Manning's Coefficient N = 0.013  
5 YEARS IDF CURVE

**CITY OF KANATA**  
**KANATA TOWN CENTRE COMMERCIAL**  
JLR 15712

**STORM SEWER DESIGN SHEET**  
NOVEMBER 1998  
REVISED JANUARY 1999

Designed by: S.E.D.  
Checked by: M.F.S.

STREET	M.H. #		AREAS FOR "R" IN (ha)					PEAK FLOW COMPUTATION				SEWER DATA						REMARKS		
	FROM	TO	0.2	0.6	0.8	0.8	0.9	2.75AR	2.75AR (CUM.)	TIME (min.)	INTENS. (mm/hr)	PEAK FL. (L/s)	DIA. (mm)	SLOPE (%)	CAPAC. (L/s)	VEL. (m/s)	LENGTH (m)		FL. TIME (min.)	
AMC Site		13					7.19	15.99	15.99										area modified to match CCL incoming flow at MH 13	
Park & Ride		13					1.34	3.35	10.33										area modified to match CCL incoming flow at MH 13	
Phase IV		13					2.77	8.94	28.28										area modified to match CCL incoming flow at MH 13	
Transitway							3.25	8.12	34.41										area modified to match CCL incoming flow at MH 13	
Hotel Road							0.17	0.73	35.13										area modified to match CCL incoming flow at MH 13	
Hotel Site							0.73	1.83	34.87										area modified to match CCL incoming flow at MH 13	
Castlefrank Road		13					1.30	5.42	42.39										area modified to match CCL incoming flow at MH 13	
Adjacent Lands		13					2.54	4.23	46.62										area modified to match CCL incoming flow at MH 13	
Esist Pond		13					0.75	0.42	47.04										area modified to match CCL incoming flow at MH 13	
Kanata North		12						4.27	8.49	86.53									area modified to match CCL incoming flow at MH 13	
Adj. Lands (east)		12						1.98	4.40	60.93									area modified to match CCL incoming flow at MH 13	
Adj. Lands (SE)		13						1.93	4.30	85.23									area modified to match CCL incoming flow at MH 13	
A	13	607					0.17	0.48	1.40	66.63	28.52	87.82	3852.52	1050	0.30	4892.06	2.33	48.40	0.35	as per CCL
F	622	621					0.43	0.23	1.47	1.47	20.00	72.56	106.50	300	2.00	136.74	1.93	87.00	0.75	not for MOE approval
F	621	620					0.10	0.77	1.83	3.40	20.75	71.05	241.77	375	2.00	247.84	2.24	84.00	0.82	not for MOE approval
F	620	607					0.32		0.71	4.11	21.37	80.86	287.44	450	2.00	403.17	2.53	88.00	0.57	not for MOE approval
A	607	606					0.28	0.75	2.31	73.08	28.87	57.38	4190.21	1800	0.22	5381.39	2.12	120.10	0.94	MOE Approved
D	631	630					1.35	0.37	3.83	3.83	20.00	72.56	277.55	525	0.50	304.08	1.40	82.00	0.97	not for MOE approval
D	630	606					0.32		0.71	4.54	20.87	70.82	320.38	525	0.75	372.42	1.72	82.00	0.88	not for MOE approval
A	608	605					0.83	0.33	7.93	85.83	28.81	56.13	4800.80	1475 x 2310	0.25	6203.38	2.28	109.80	0.81	MOE Approved
	605	604					0.31	0.83	2.54	88.06	30.82	85.01	4864.34	1475 x 2310	0.25	6203.38	2.28	87.00	0.48	MOE Approved (Length Revised)
	604	pond							0.00	100.45	31.11	54.17	5441.77	1475 x 2310	0.25	6203.38	2.28	48.00	0.30	MOE Approved (Flows from 601 to 604 added)
							1.54	4.01	3.30	22.13	0.57	100.45	100.45							COMPARISON
E	642	641					1.00	0.23	2.74	3.74	20.00	72.56	198.44	450	0.40	228.83	1.38	82.00	0.74	not for MOE approval
B	650	641					0.21		0.47	0.47	20.00	72.56	33.89	300	1.00	86.69	1.37	88.00	1.07	not for MOE approval
E	641	640					0.37		0.40	3.80	21.07	70.42	287.84	525	0.50	304.08	1.40	70.00	0.83	not for MOE approval
E	640	602					1.28		2.87	8.87	21.90	88.09	458.69	800	0.80	475.58	1.88	65.00	0.84	not for MOE approval
A	603	602					0.80	0.29	2.15	2.15	20.00	72.56	155.72	375	1.80	214.72	1.84	85.00	0.58	not for MOE approval
A	602	601					0.78	0.56	3.38	12.38	22.55	67.77	638.83	600	2.00	888.28	3.07	85.00	0.25	not for MOE approval
A	601	604							0.00	12.38	22.42	87.88	842.54	675	1.40	894.54	2.78	73.10	0.44	MOE Approved (Diameter and Length Revised)
							0.78	1.48	2.11	2.17	0.00	12.38	12.38							COMPARISON
FUTURE COMMERCIAL		pond					2.17		4.83	4.83	20.00	72.56	350.17	600	0.40	388.31	1.37	85.00	0.78	not for MOE approval
							0.00	0.00	0.00	2.17	0.00	4.83	4.83							COMPARISON





# APPENDIX

**C**

Existing Site Conditions



DATA COLLECTION SKETCH OF

PART OF LOT 3 CONCESSION 2  
PART OF LOT 3 CONCESSION 3  
AND PART OF ROAD ALLOWANCE  
BETWEEN CONCESSION 2 AND 3  
(CLOSED BY INST. LT278660)  
GEOGRAPHIC TOWNSHIP OF MARCH  
CITY OF OTTAWA

Prepared by Annis, O'Sullivan, Vollebek Ltd.  
Field Work Completed February 10, 2020.

Scale 1 : 500



Metric  
DISTANCES SHOWN ON THIS PLAN ARE IN METRES AND  
CAN BE CONVERTED TO FEET BY DIVIDING BY 0.3048

Notes & Legend

- M+S - Maintenance Hole (Sanitary)
- M+H - Maintenance Hole (Bell Telephone)
- M+U - Maintenance Hole (Hydro)
- M+I - Maintenance Hole (Unidentified)
- VC - Valve Chamber (Watermain)
- FH - Fire Hydrant
- LS - Light Standard
- △ S - Sign
- WV - Water Valve
- PWF - Post & Wire Fence
- + 65.00 - Location of Elevations
- + 66.00 - Top of Concrete Curb Elevation

Distances shown on this plan are ground distances and can be converted to grid distances by multiplying by the combined scale factor of 0.999911.

SITE AREA = 37064.5 m<sup>2</sup>

BOUNDARY INFORMATION COMPILED FROM PLAN 4R-32488.

ELEVATION NOTES

1. Elevations shown are geodetic and are referred to the CGVD28 geodetic datum.
2. It is the responsibility of the user of this information to verify that the job benchmark has not been altered or disturbed and that its relative elevation and description agrees with the information shown on this drawing.

UTILITY NOTES

1. This drawing cannot be accepted as acknowledging all of the utilities and it will be the responsibility of the user to contact the respective utility authorities for confirmation.
2. Only visible surface utilities were located.
3. A field location of underground plant by the pertinent utility authority is mandatory before any work involving breaking ground, probing, excavating etc.

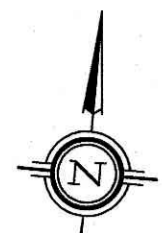
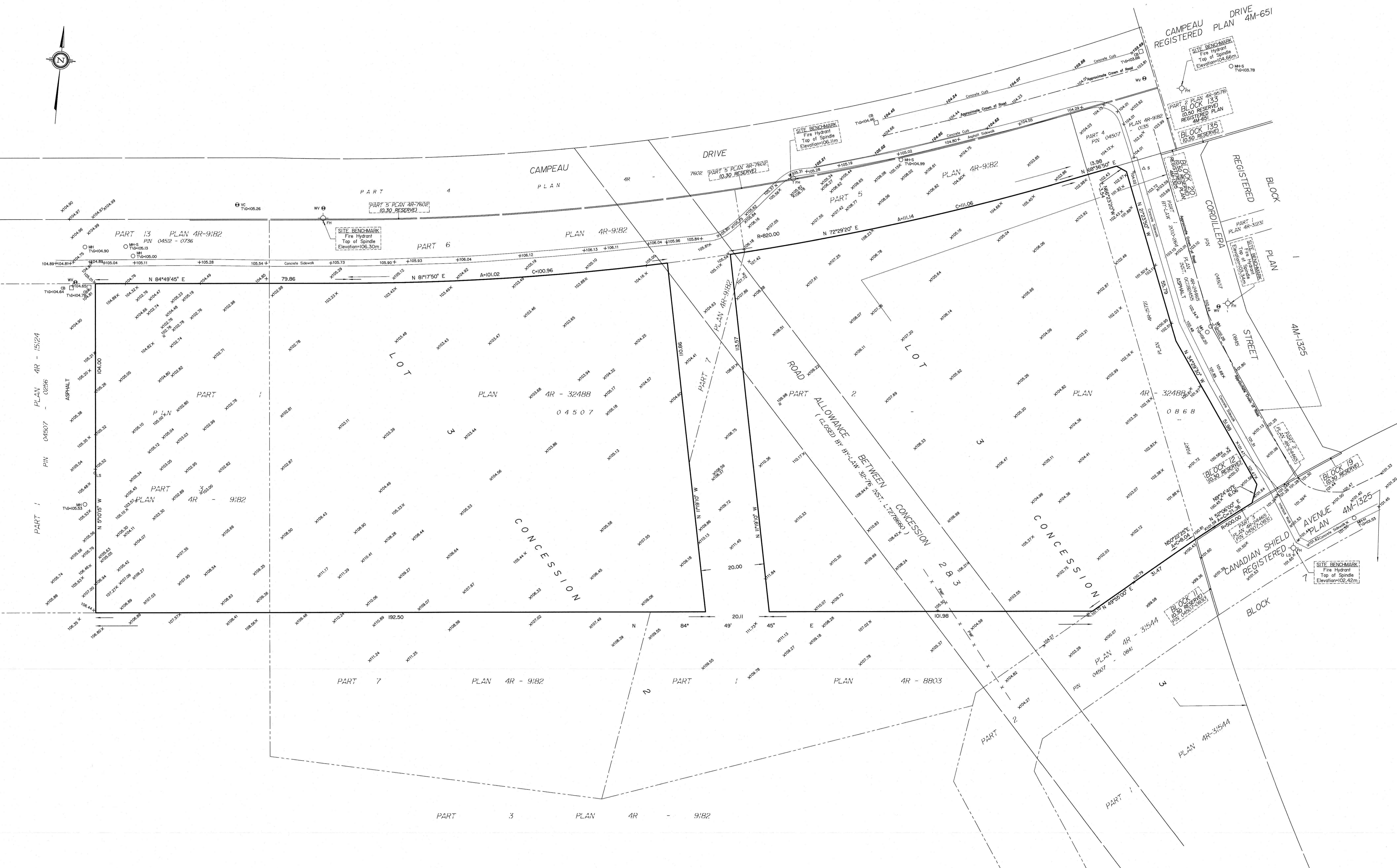

# APPENDIX

**D**

Stormwater Management  
Calculations

# APPENDIX

## D-1 Pre-development Calculations

	<b>Stormwater Management Calculations</b>	<b>Project: 6301 Campeau Drive No.: 201-03048-00</b>	
	<b>Release Rates - Parcel 1</b>	<b>By: MS</b>	<b>Date: 2020-02-21</b>
		<b>Checked: BW</b>	<b>Page: 1</b>

Step 1: Determine Pre-development Flow using Rational Formula

\* Runoff Coefficient, C in accordance with City of Ottawa Sewer Design Guidelines (section 8.3.7.3)

Return Period	2	5	10	25	50	100
C Multiplier (OSDG Table 5.7) =	1.00	1.00	1.00	1.10	1.20	1.25
Runoff Coefficient, C =	0.20	0.20	0.20	0.22	0.24	0.25

Rainfall intensity calculated in accordance with City of Ottawa Sewer Design Guidelines (section 5.4.2):

$$i = \left[ \frac{A}{(Td + C)^B} \right]$$

Where: A, B, C = regression constants for each return period (defined in section 5.4.2)

i = rainfall intensity (mm/hour)

Td = storm duration (minutes)

Time of Concentration = 20 minutes

Catchment Area = 1.8 ha

Return Period	2	5	10	25	50	100
a =	733.0	998.1	1,174.2	1,402.9	1,569.6	1,735.7
b =	0.810	0.814	0.816	0.819	0.820	0.820
c =	6.199	6.053	6.014	6.018	6.014	6.014
Intensity <sub>peak</sub> (mm/hr) =	52.0	70.3	82.2	97.3	108.5	120.0
Q <sub>peak</sub> (L/s) =	52.0	70.3	82.2	107.0	130.2	149.9
Q <sub>peak</sub> (m <sup>3</sup> /s) =	0.052	0.070	0.082	0.107	0.130	0.150

Return Period = 5 year

Q = 70.3 L/s Pre-development flow rate

Conclusion:

**The 5-year pre-development flow rate for a 20-minute Tc governs the 100-year maximum post-development release rate for Parcel 1 and is 70.3 L/s.**

Filepath:

\\corp.pbwan.net\ca\CAOTT300\CAOTT100DAT01\data\data2\L\Water Resources\Projects\2020\201-03048-00\_6301 Campeau Drive\Analysis\2021-05-17 6301 Campeau Drive.xlsx\IDF Calcs - 1

	<b>Stormwater Management Calculations</b>	<b>Project: 6301 Campeau Drive</b>	<b>No.: 201-03048-00</b>	
	<b>Release Rates - Parcel 2 to Cordillera Street</b>	<b>By: MS</b>	<b>Date: 2020-02-21</b>	<b>Page: 2</b>
		<b>Checked: BW</b>		

Step 1: Determine Pre-development Flow using Rational Formula

\* Runoff Coefficient, C in accordance with JLR Report per Appendix B-3

Return Period	2	5	10	25	50	100
C Multiplier (OSDG Table 5.7) =	1.00	1.00	1.00	1.10	1.20	1.25
Runoff Coefficient, C =	0.80	0.80	0.80	0.88	0.96	1.00

Rainfall intensity calculated in accordance with City of Ottawa Sewer Design Guidelines (section 5.4.2):

$$i = \left[ \frac{A}{(Td + C)^B} \right]$$

Where: A, B, C = regression constants for each return period (defined in section 5.4.2)

i = rainfall intensity (mm/hour)

Td = storm duration (minutes)

Time of Concentration = 20 minutes

Catchment Area = 0.2506 ha      1.74 ha. Site Area; 0.25 ha. Draining to Cordillera

Return Period	2	5	10	25	50	100
a =	733.0	998.1	1,174.2	1,402.9	1,569.6	1,735.7
b =	0.810	0.814	0.816	0.819	0.820	0.820
c =	6.199	6.053	6.014	6.018	6.014	6.014
Intensity <sub>peak</sub> (mm/hr) =	52.0	70.3	82.2	97.3	108.5	120.0
Q <sub>peak</sub> (L/s) =	29.0	39.1	45.8	59.6	72.5	83.5
Q <sub>peak</sub> (m <sup>3</sup> /s) =	0.029	0.039	0.046	0.060	0.072	0.083

Return Period = 5 year

Q = 39.1 L/s      Pre-development flow rate

Sewer Capacity = 60.0 L/s      Capacity as provided by the City of Ottawa

Conclusion:

**The sewer capacity along Cordillera Street governs the minor system allowable release rate at 60 L/s**

Filepath:

\\corp.pbwan.net\ca\CAOTT300\CAOTT100DAT01\data\data2\L\Water Resources\Projects\2020\201-03048-00\_6301 Campeau Drive\Analysis\2021-05-17 6301 Campeau Drive.xlsx\IDF Calcs - 2

# APPENDIX

## D-2 Post-Development Calculations



Stormwater Management Calculations	Project: 6301 Campeau Drive	No.:	201-03048-00
	Time of Concentration	By: MS	Date: 2020-02-21
		Checked:	Page: 3

Parcel 1				
	Cistern Controlled Area	Undeveloped/ Routed around controls		Notes
Watershed Area	1.521	1.571	ha	Area Draining to outlet (excluding undeveloped areas)
Slope	0.005	0.005	m/m	Average Slope Approximated
Flow Length (pavement)	30	0	m	Manually Measured
Flow Length (vegetated)	40	288	m	
Total	70	280	m	
Roughness	0.023	0.035	-	Calculated as n = 0.013 for concrete and n = 0.035 for grassed area along measured flow path
100-year Rational 'C'	0.74	0.21	-	Average C for areas draining to Cistern + Pipe Storage
i, 100-years	178.6	178.6	mm/hr	~100-year ToC 10-minute intensity - Used for Kinematic wave
Pipe Length	155	0	m	Approximate Length from drainage Plan
Pipe Velocity	0.87	0.87	m/s	From Sewer Design Sheet (Average)
Pipe Time	3.0	0.0	min	
Kinematic Wave Equation	8.6	16.8	min	Times include 'Pipe Time'
Bransby Williams	7.4	17.7	min	
Federal Aviation Agency	15.3	61.0	min	
Average	10.4	17.2		

Conclusion:

Removing the Federal Aviation Agency Method (outlier) leaves and average Time of concentration of 17.2 min for the uncontrolled areas

Filepath:

\\corp.pbwan.net\ca\CAOTT300\CAOTT100DAT01\data\data2\Water Resources\Projects\2020\201-03048-00\_6301 Campeau Drive\Analysis\2021-05-27 6301 Campeau Drive.xlsx\ToC appen





Stormwater Management Calculations

Project: 6301 Campeau Drive

No.: 201-03048-00

Orifice Control Rate Checks

By: MS

Date: 2020-02-21

Page:

Checked:

4

Orifice sizing was determined iteratively using computer software (HydroCAD, Parcel 1 and PCSWMM, Parcel 2). This design sheet confirms the specified sizing calculation under the orifice equation.

Orifice Equation:

$$Q = C \times A \times (2 \times g \times h)^{0.5}$$

Where:

Parameter	Value	Units	Notes
Q =	Calc	m <sup>3</sup> /s	Flow through orifice device
C =	0.6	-	Orifice Coefficient
A =	Calc	m <sup>2</sup>	orifice opening area (m <sup>2</sup> )
g =	9.81	m/s <sup>2</sup>	gravatational constant
h =	Calc	m	height from peak water level to centreline of orifice

**Parcel 1**

Parameter	Value	Units	Notes
Orifice Diameter =	0.122	m	
Orifice Area =	0.01169	m <sup>2</sup>	
Orifice Invert =	103.154	m	
CL of Orifice =	103.192	m	
Top of Cistern =	104.085	m	
h =	0.89	m	
Q_Max =	0.029	m <sup>3</sup> /s	
	29.37	L/s	

**Parcel 2**

Parameter	Value	Units	Notes
Orifice Diameter =	0.15	m	
Orifice Area =	0.017671	m <sup>2</sup>	
Orifice Invert =	99.305	m	
CL of Orifice =	99.38	m	
Top of Cistern =	100.81	m	
h =	1.43	m	
Q_Max =	0.056	m <sup>3</sup> /s	
	56.16	L/s	

# APPENDIX

**E**

Proposed Site – Annotated Storm  
Drainage Plan



PROJECT: 6301 CAMPEAU DRIVE

DATE: 2021-05-11

PROJECT NO.: 201-03048-00

DRAWING NAME: OVERALL STORM DRAINAGE PLAN

REVIEWED BY:

SCALE: 1:300

- Pipe and Cistern Controlled
  - Uncontrolled
  - Rooftop Controlled
  - Undeveloped
  - Stormwater Cistern
  - Area Draining to Future Canadian Shield Avenue
- \*NOTE THESE AREAS ARE REMAINING UNDEVELOPED AND ARE NOT PASSING THROUGH ANY CONTROL (ROOF/PIPE/CISTERN) AND THEREFORE WERE EXCLUDED FROM THE ALLOWABLE DISCHARGE CALCULATION

DESIGNED BY: D.Y.

DRAWN BY: D.Y.

SHEET: Fig3

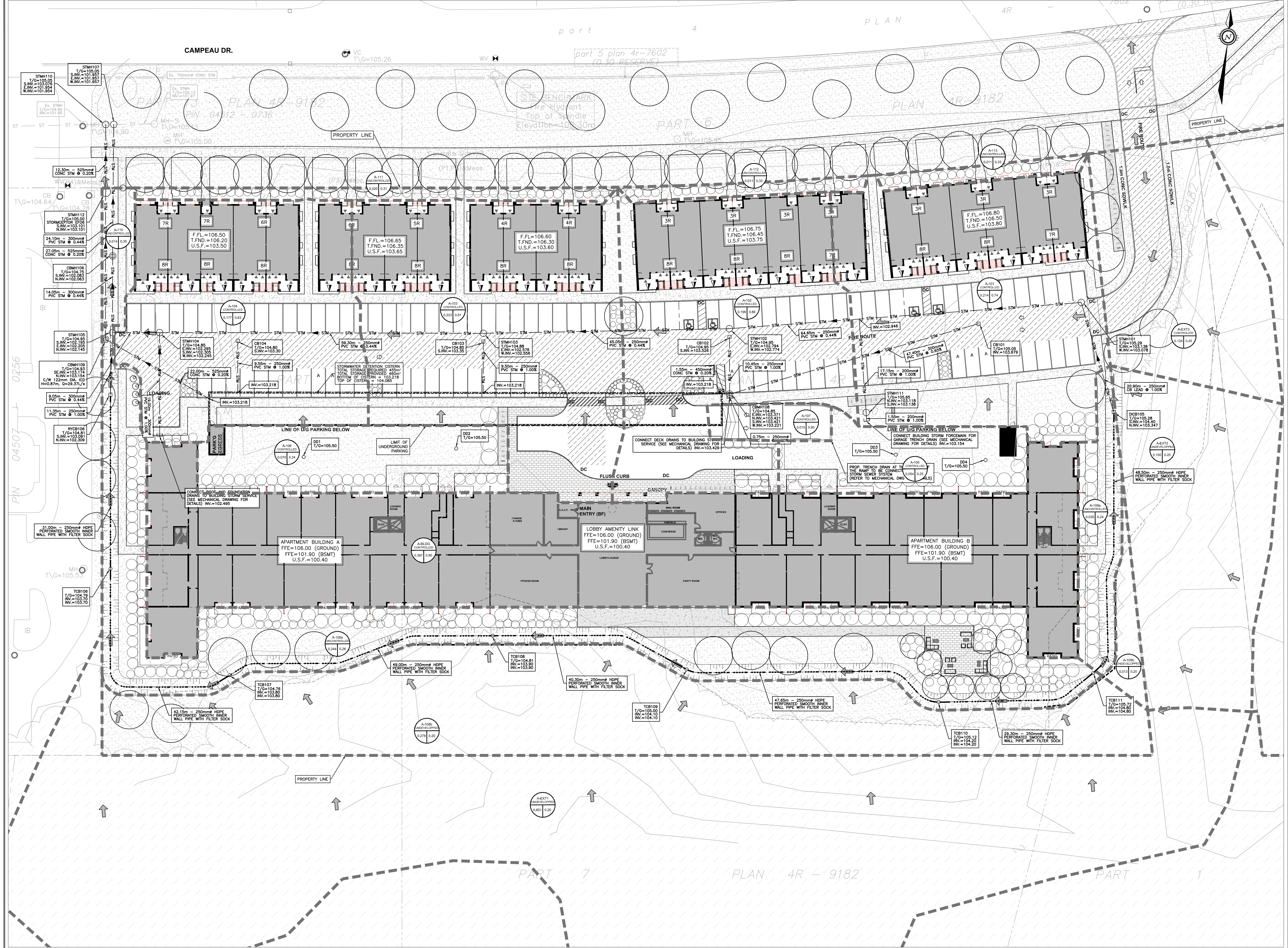

**GENERAL NOTES:**  
 THE ENGINEER WAIVES ANY AND ALL RESPONSIBILITY AND LIABILITY FOR PROBLEMS WHICH ARISE FROM FAILURE TO FOLLOW THE PLANS, SPECIFICATIONS AND THE DESIGN INTENT TO CONVEY, OR FOR PROBLEMS WHICH ARISE FROM OTHERS FAILURE TO OBTAIN AND/OR FOLLOW THE ENGINEERS GUIDANCE WITH RESPECT TO ANY ERRORS, OMISSIONS, INCONSISTENCIES AMBIGUITIES OR CONFLICTS WHICH ARE ALLEGED.  
 CONTRACTOR TO VERIFY ALL DIMENSIONS AND NOTIFY THE ENGINEER OF ANY DISCREPANCIES BEFORE WORK COMMENCES. DO NOT SCALE DRAWINGS.

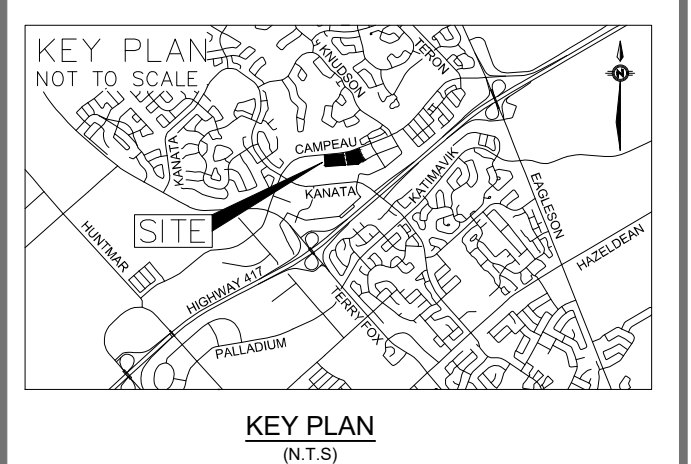

No.	REVISIONS	BY	DATE
02	REVISED AS PER CITY COMMENTS	D.Y.	2021-05-28
01	ISSUED FOR SPA	D.Y.	2021-10-14

HORIZONTAL SCALE:  
 SCALE: 1:300

DISTANCES SHOWN ON THIS PLAN ARE IN METRES AND CAN BE CONVERTED TO FEET BY DIVIDING BY 0.3048



NOT VALID UNLESS SIGNED AND DATED

**wsp**

2611 Queensview Dr. Ottawa, ON Canada K2B 8K2  
 t: 613.829.2800 f: 613.829.8299 www.wspgroup.com



ANNIS, O'SULLIVAN, VOLLEBEKK  
 Ontario Land Surveyors  
 14 CONCRETE GATE, SUITE 100, WERAN, ONTARIO, K2E 7J6  
 TEL: (613) 727-0850 FAX: (613) 727-1079

DESIGNED BY: D.Y. DRAWN BY: D.Y. APPROVED BY: D.Y./J.J.

**6301 CAMPEAU DRIVE  
 RESIDENTIAL DEVELOPMENT**

DRAWING TITLE  
**STORM DRAINAGE AREA PLAN  
 PARCEL 1**

PROJECT NO.  
 201-03048-00

DRAWING NO.  
 C06

FILENAME: V:\15\_13\_ML1D\_2020\Projects\201-03048-00\_0301\Campeau\_Dev\3\_Drainage\Working\Drawings\201-03048-00\_C\_06.dwg  
 PLOTDATE: May 28, 2021 4:48pm User:09241

D07-12-20-0171  
 #18353

**GENERAL NOTES:**  
 THE ENGINEER WAIVES ANY AND ALL RESPONSIBILITY AND LIABILITY FOR PROBLEMS WHICH ARISE FROM FAILURE TO FOLLOW THE PLANS, SPECIFICATIONS AND THE DESIGN INTENT THEY CONVEY, OR FOR PROBLEMS WHICH ARISE FROM OTHERS FAILURE TO OBTAIN AND/OR FOLLOW THE ENGINEERS GUIDANCE WITH RESPECT TO ANY ERRORS, OMISSIONS, INCONSISTENCIES AMBIGUITIES OR CONFLICTS WHICH ARE ALLEGED.  
 CONTRACTOR TO VERIFY ALL DIMENSIONS AND NOTIFY THE ENGINEER OF ANY DISCREPANCIES BEFORE WORK COMMENCES. DO NOT SCALE DRAWINGS.

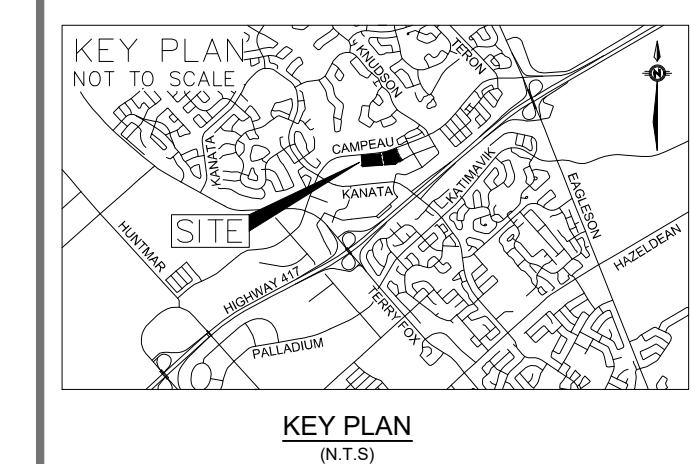

No.	REVISIONS	BY	DATE
02	REVISED AS PER CITY COMMENTS	D.Y.	2021-05-28
01	ISSUED FOR SPA	D.Y.	2020-12-04

HORIZONTAL SCALE:  
 SCALE: 1:300  
 DISTANCES SHOWN ON THIS PLAN ARE IN METRES AND CAN BE CONVERTED TO FEET BY DIVIDING BY 0.3048



NOT VALID UNLESS SIGNED AND DATED

**wsp**

2811 Queensview Dr. Ottawa, ON Canada K2B 8K2  
 t: 613.829.2800 f: 613.829.8299 www.wspgroup.com



ANNIS, O'SULLIVAN, VOLLEBEKK  
 Ontario Land Surveyors  
 14 CONCRETE GATE, SUITE 100, WERAN, ONTARIO, K2E 7S6  
 TEL: (613) 727-0850 FAX: (613) 727-1079

DESIGNED BY: D.Y. DRAWN BY: D.Y. APPROVED BY: D.Y./J.J.

PROJECT: 6301 CAMPEAU DRIVE RESIDENTIAL DEVELOPMENT

DRAWING TITLE: STORM DRAINAGE AREA PLAN PARCEL 2

PROJECT NO: 201-03048-00 DRAWING NO: C07



FILENAME: V:\10\_13\_16\10\_2020\Projects\201-03048-00\_0301\Campeau\_Dev\3\_Drainage\Working\Drawings\201-03048-00\_C\_409  
 PLOTDATE: May 28, 2021 4:48pm User:099241

# APPENDIX

# F

Product Calculations and  
Documentation

# APPENDIX

## F-1 Roof Drains

	Stormwater Management Calculations	Project: 6301 Campeau Drive	No.: 201-03048-00
	Roof Drains	By: MS	Date: 2020-02-21
		Checked:	

**Watts Adjustable Accutrol Weir**

IMPERIAL	Flow Rate (GPM)					
	1"	2"	3"	4"	5"	6"
Fully Exposed	5	10	15	20	25	30
3/4	5	10	13.75	17.5	21.25	25
1/2	5	10	12.5	15	17.5	20
1/4	5	10	11.25	12.5	13.75	15
Closed	5	5	5	5	5	5

1 GPM = 0.000063 m3/sec  
1" = 25.4 mm

METRIC	Flow Rate (m3/sec)					
	25.4	50.8	76.2	101.6	127.0	152.4
Fully Exposed	0.000315	0.000630902	0.000946353	0.001262	0.001577	0.001893
3/4	0.000315	0.000630902	0.00086749	0.001104	0.001341	0.001577
1/2	0.000315	0.000630902	0.000788628	0.000946	0.001104	0.001262
1/4	0.000315	0.000630902	0.000709765	0.000789	0.000867	0.000946
Closed	0.000315	0.000315451	0.000315451	0.000315	0.000315	0.000315

Building	Parcel	Status	Common Name	Drainage Area (ha.)	Drainage Area (m <sup>2</sup> )	Area to Cistern 1 (m <sup>2</sup> )	Area controlled by Rooftop (m <sup>2</sup> )	Drains Provided	Roof (%) with Controls
AB-BLDG	1	3/4 Exposed	Building	0.387	3870	0	3794	7	98%
C-BLDG	2	1/4 Exposed	Building	0.276	2760	0	2135	15	77%

Filepath:

\\corp.pbwan.net\ca\CAOTT300\CAOTT100DAT01\data\data2\L\Water Resources\Projects\2020\201-03048-00\_6301 Campeau Drive\Analysis\2021-05-27 6301 Campeau Drive.xlsx\Watts Drains



# APPENDIX

## **F-2** Parcel 1 Oil-Grit Separator

# Hydrodynamic Separation Product Calculator

Campeau Drive  
 6301 Campeau Drive Parcel 1  
 CASCADE SEPARATOR CS-5

Project Information					
Project Name	Campeau Drive			Option #	A
Country	Metric	State	N/A	City	N/A

Contact Information			
First Name	Mihael	Last Name	Stewart
Company		Phone #	587-489-0196
Email	Michael.stewart@wsp.com		

Design Criteria					
Site Designation	6301 Campeau Drive Parcel 1			Sizing Method	Net Annual
Screening Required?	No	Drainage Area (ac)	1.46	Peak Flow (cfs)	71.40
Groundwater Depth (ft)	>15	Pipe Invert Depth (ft)	>15	Bedrock Depth (ft)	>15
Multiple Inlets?	No	Grate Inlet Required?	No	Pipe Size (in)	600.00
Required Particle Size Distribution?	Yes	90° between two inlets?	N/A	180° between inlet and outlet?	No
Runoff Coefficient	0.89	Rainfall Station	128 - Ottawa, ON	TC (Min)	10

Treatment Selection					
Treatment Unit	CASCADE SEPARATOR	System Model	CS-5		
Target Removal	80%	Particle Size Distribution (PSD)	110	Predicted Net Annual Removal	84.99%

**PRELIMINARY SIZING ONLY. ALL DETAILS TO BE CONFIRMED IF OGS IS REQUIRED.**

\*Treatment flow rate calculated using annualized weighted calculation.

# Hydrodynamic Separation Product Calculator

Campeau Drive

6301 Campeau Drive Parcel 1

CASCADE SEPARATOR CS-5

CASCADE SEPARATOR ESTIMATED NET ANNUAL SOLIDS LOAD REDUCTION BASED ON THE RATIONAL RAINFALL METHOD									
Rainfall Intensity <sup>1</sup> (in/hr)	% Rainfall Volume <sup>1</sup>	Cumulative Rainfall Volume	Rainfall Volume Treated	Total Flowrate (cfs)	Treated Flowrate (cfs)	Hydraulic Loading Rate (%)	Removal Efficiency (%)	Incremental Removal (%)	
0.0200	10.70%	10.70%	10.70%	0.0600	0.0600	%	100.00%	10.71%	
0.0400	9.30%	20.00%	9.30%	0.1300	0.1300	%	100.00%	9.30%	
0.0600	10.30%	30.30%	10.30%	0.1900	0.1900	%	100.00%	10.26%	
0.0800	8.60%	38.90%	8.60%	0.2600	0.2600	%	100.00%	8.56%	
0.1000	6.70%	45.60%	6.70%	0.3200	0.3200	%	100.00%	6.74%	
0.1200	5.80%	51.40%	5.80%	0.3900	0.3900	%	100.00%	5.82%	
0.1400	5.00%	56.40%	5.00%	0.4500	0.4500	%	100.00%	5.03%	
0.1600	4.40%	60.80%	4.40%	0.5100	0.5100	%	100.00%	4.38%	
0.1800	2.30%	63.10%	2.30%	0.5800	0.5800	%	99.44%	2.32%	
0.2000	4.20%	67.30%	4.20%	0.6400	0.6400	%	98.15%	4.07%	
0.2500	7.40%	74.70%	7.40%	0.8000	0.8000	%	94.71%	6.99%	
0.3000	4.00%	78.70%	4.00%	0.9600	0.9600	%	91.27%	3.69%	
0.3500	3.50%	82.20%	3.50%	1.1200	1.1200	%	87.83%	3.08%	
0.4000	1.80%	84.00%	1.80%	1.2800	1.2800	%	84.39%	1.55%	
0.4500	3.80%	87.80%	3.80%	1.4400	1.4400	%	80.96%	3.06%	
0.5000	1.40%	89.20%	1.40%	1.6100	1.6100	%	77.30%	1.09%	
0.7500	5.20%	94.40%	5.20%	2.4100	2.4100	%	60.11%	3.13%	
1.0000	2.40%	96.80%	2.40%	3.2100	3.2100	%	42.90%	1.04%	
1.5000	2.30%	99.10%	1.67%	4.8200	3.5000	%	26.63%	0.62%	
								91.44%	
								Removal Efficiency Adjustment <sup>2</sup> =	6.45%
								Predicted % Annual Rainfall Treated =	92.02%
								Predicted Net Annual Load Removal Efficiency =	84.99%
1 - Based on 10 years of rainfall data from Canadian Station 6105976, Ottawa CDA, ON									
2 - Reduction due to use of 60-minute data for a site that has a time of concentration less than 30-minutes.									

PRELIMINARY SIZING ONLY. ALL DETAILS TO BE CONFIRMED IF OGS IS REQUIRED.

\*Treatment flow rate calculated using annualized weighted calculation.

I:\COMMON\CAD\TREATMENT\21 CASCADE\40 STANDARD DRAWINGS\DWG\CS-5-DTL.DWG 1/22/2019 9:35 AM

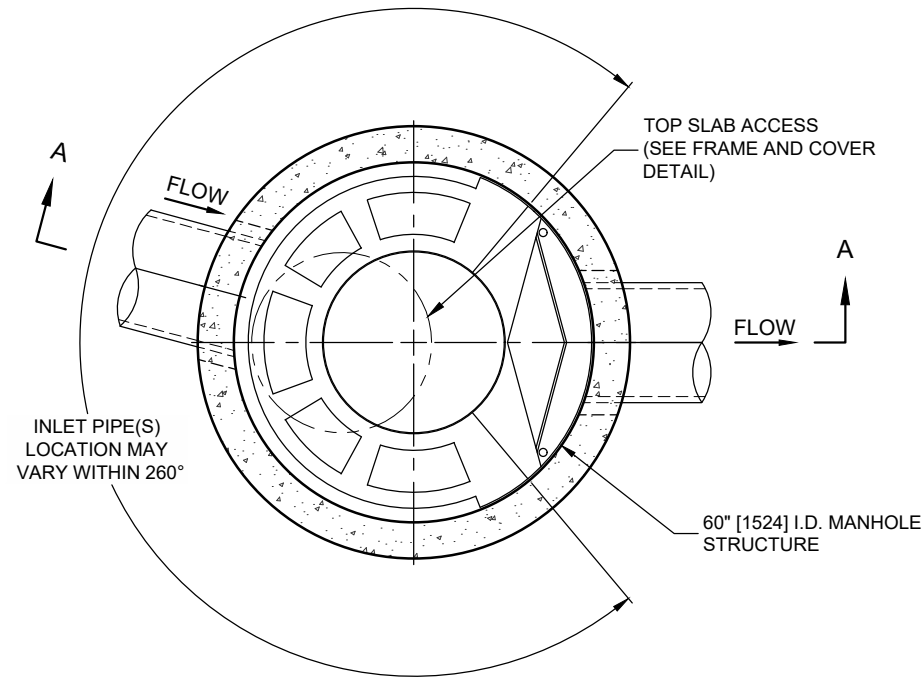

**PLAN VIEW B-B**  
NOT TO SCALE

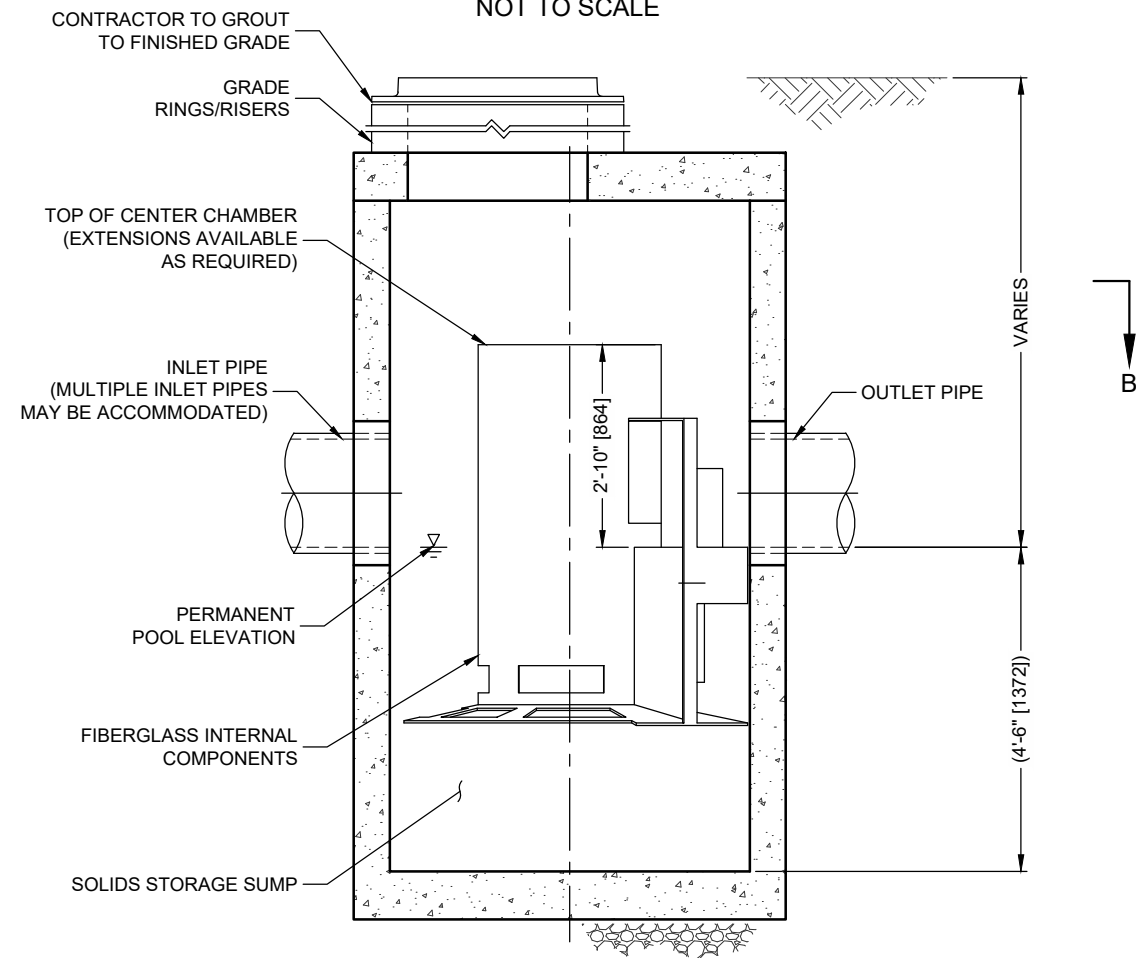

**ELEVATION A-A**  
NOT TO SCALE

**CASCADE**  
separator™

**CASCADE SEPARATOR DESIGN NOTES**

THE STANDARD CS-5 CONFIGURATION IS SHOWN. ALTERNATE CONFIGURATIONS ARE AVAILABLE AND ARE LISTED BELOW. SOME CONFIGURATIONS MAY BE COMBINED TO SUIT SITE REQUIREMENTS.

**CONFIGURATION DESCRIPTION**

- GRATED INLET ONLY (NO INLET PIPE)
- GRATED INLET WITH INLET PIPE OR PIPES
- CURB INLET ONLY (NO INLET PIPE)
- CURB INLET WITH INLET PIPE OR PIPES

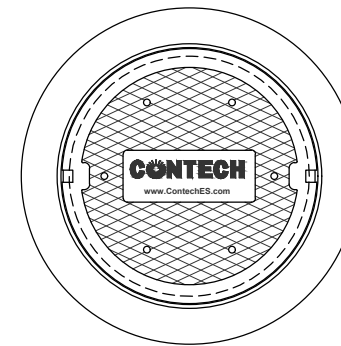

**FRAME AND COVER**  
(DIAMETER VARIES)  
NOT TO SCALE

**SITE SPECIFIC DATA REQUIREMENTS**

STRUCTURE ID			
WATER QUALITY FLOW RATE (cfs [L/s])			
PEAK FLOW RATE (cfs [L/s])			
RETURN PERIOD OF PEAK FLOW (yrs)			
RIM ELEVATION			
PIPE DATA:	INVERT	MATERIAL	DIAMETER
INLET PIPE 1			
INLET PIPE 2			
OUTLET PIPE			

NOTES / SPECIAL REQUIREMENTS:

**PRELIMINARY SIZING ONLY. ALL DETAILS TO BE CONFIRMED IF OGS IS REQUIRED.**

**GENERAL NOTES**

1. CONTECH TO PROVIDE ALL MATERIALS UNLESS NOTED OTHERWISE.
2. FOR SITE SPECIFIC DRAWINGS WITH DETAILED STRUCTURE DIMENSIONS AND WEIGHT, PLEASE CONTACT YOUR CONTECH ENGINEERED SOLUTIONS LLC REPRESENTATIVE. [www.ContechES.com](http://www.ContechES.com)
3. CASCADE SEPARATOR WATER QUALITY STRUCTURE SHALL BE IN ACCORDANCE WITH ALL DESIGN DATA AND INFORMATION CONTAINED IN THIS DRAWING. CONTRACTOR TO CONFIRM STRUCTURE MEETS REQUIREMENTS OF PROJECT.
4. CASCADE SEPARATOR STRUCTURE SHALL MEET AASHTO HS20 LOAD RATING, ASSUMING EARTH COVER OF 0' - 2' [610], AND GROUNDWATER ELEVATION AT, OR BELOW, THE OUTLET PIPE INVERT ELEVATION. ENGINEER OF RECORD TO CONFIRM ACTUAL GROUNDWATER ELEVATION. CASTINGS SHALL MEET AASHTO M306 AND BE CAST WITH THE CONTECH LOGO.
5. CASCADE SEPARATOR STRUCTURE SHALL BE PRECAST CONCRETE CONFORMING TO ASTM C478 AND AASHTO LOAD FACTOR DESIGN METHOD.
6. ALTERNATE UNITS ARE SHOWN IN MILLIMETERS [mm].

**INSTALLATION NOTES**

- A. ANY SUB-BASE, BACKFILL DEPTH, AND/OR ANTI-FLOTATION PROVISIONS ARE SITE-SPECIFIC DESIGN CONSIDERATIONS AND SHALL BE SPECIFIED BY ENGINEER OF RECORD.
- B. CONTRACTOR TO PROVIDE EQUIPMENT WITH SUFFICIENT LIFTING AND REACH CAPACITY TO LIFT AND SET THE CASCADE SEPARATOR MANHOLE STRUCTURE.
- C. CONTRACTOR TO INSTALL JOINT SEALANT BETWEEN ALL STRUCTURE SECTIONS AND ASSEMBLE STRUCTURE.
- D. CONTRACTOR TO PROVIDE, INSTALL, AND GROUT INLET AND OUTLET PIPE(S). MATCH PIPE INVERTS WITH ELEVATIONS SHOWN. ALL PIPE CENTERLINES TO MATCH PIPE OPENING CENTERLINES.
- E. CONTRACTOR TO TAKE APPROPRIATE MEASURES TO ASSURE UNIT IS WATER TIGHT, HOLDING WATER TO FLOWLINE INVERT MINIMUM. IT IS SUGGESTED THAT ALL JOINTS BELOW PIPE INVERTS ARE GROUTED.

**CONTECH**  
ENGINEERED SOLUTIONS LLC

[www.contechES.com](http://www.contechES.com)  
9025 Centre Pointe Dr., Suite 400, West Chester, OH 45069  
800-338-1122 513-645-7000 513-645-7993 FAX

CS-5  
CASCADE SEPARATOR  
STANDARD DETAIL

# APPENDIX

**G**

Parcel 1 – Model Output  
(HydroCAD)

**6301 Campeu Drive  
Parcel 1**

5-year C

Peak Discharge (Td = 18 min)

Cistern Controlled

Controlled Building  
Areas with Rooftop  
Storage

Light Blue Areas



Dark Blue Areas

Controlled - Pipe +  
Cistern

Controlled - Rooftop  
Storage



Cistern + Pipe Storage

Rooftop Storage

Max Allowable Release  
= 70.3 /s in 100-Year

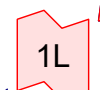

Red Areas

Site Release

Uncontrolled Site Areas

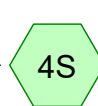
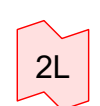

Green Areas

Total Site Outflow

Undeveloped Areas  
Directed Downstream  
of Controls

Undeveloped (Bypass  
Controls)

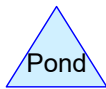
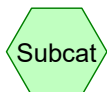

**Routing Diagram for CampeuDrive\_Parcel 1 5-yr**  
Prepared by WSP Canada inc., Printed 2021-05-27  
HydroCAD® 10.00-21 s/n 10060 © 2018 HydroCAD Software Solutions LLC

# CampeauDrive\_Parcel 1 5-yr

Prepared by WSP Canada inc.

HydroCAD® 10.00-21 s/n 10060 © 2018 HydroCAD Software Solutions LLC

Printed 2021-05-27

Page 2

## Area Listing (all nodes)

Area (sq-meters)	C	Description (subcatchment-numbers)
2,140.0	0.74	A-101 (1S)
1,990.0	0.86	A-102 (1S)
2,230.0	0.81	A-103 (1S)
1,770.0	0.83	A-104 (1S)
540.0	0.25	A-105 (1S)
700.0	0.24	A-106 (1S)
150.0	0.90	A-107 (1S)
2,440.0	0.26	A-108a (3S)
2,780.0	0.20	A-108b (4S)
350.0	0.24	A-109a (3S)
130.0	0.20	A-109b (4S)
140.0	0.35	A-110 (3S)
200.0	0.31	A-111 (3S)
110.0	0.33	A-112 (3S)
110.0	0.33	A-113 (3S)
3,870.0	0.90	A-BLDG (2S)
8,510.0	0.20	A-EXT1 (4S)
1,500.0	0.20	A-EXT2 (4S)
1,240.0	0.45	A-EXT3 (1S)
<b>30,900.0</b>	<b>0.47</b>	<b>TOTAL AREA</b>

**Summary for Subcatchment 1S: Controlled - Pipe + Cistern**

Runoff = 0.1569 m³/s @ 0.17 hrs, Volume= 169.4 m³, Depth= 16 mm

Runoff by Rational method, Rise/Fall=1.0/1.0 xTc, Time Span= 0.00-4.00 hrs, dt= 0.01 hrs  
 Ottawa 5-Year Duration=18 min, Inten=75.0 mm/hr

Area (m²)	C	Description
2,140.0	0.74	A-101
1,990.0	0.86	A-102
2,230.0	0.81	A-103
1,770.0	0.83	A-104
540.0	0.25	A-105
700.0	0.24	A-106
150.0	0.90	A-107
1,240.0	0.45	A-EXT3
10,760.0	0.70	Weighted Average
10,760.0		100.00% Pervious Area

Tc (min)	Length (meters)	Slope (m/m)	Velocity (m/sec)	Capacity (m³/s)	Description
10.0					Direct Entry,

**Subcatchment 1S: Controlled - Pipe + Cistern**

Hydrograph

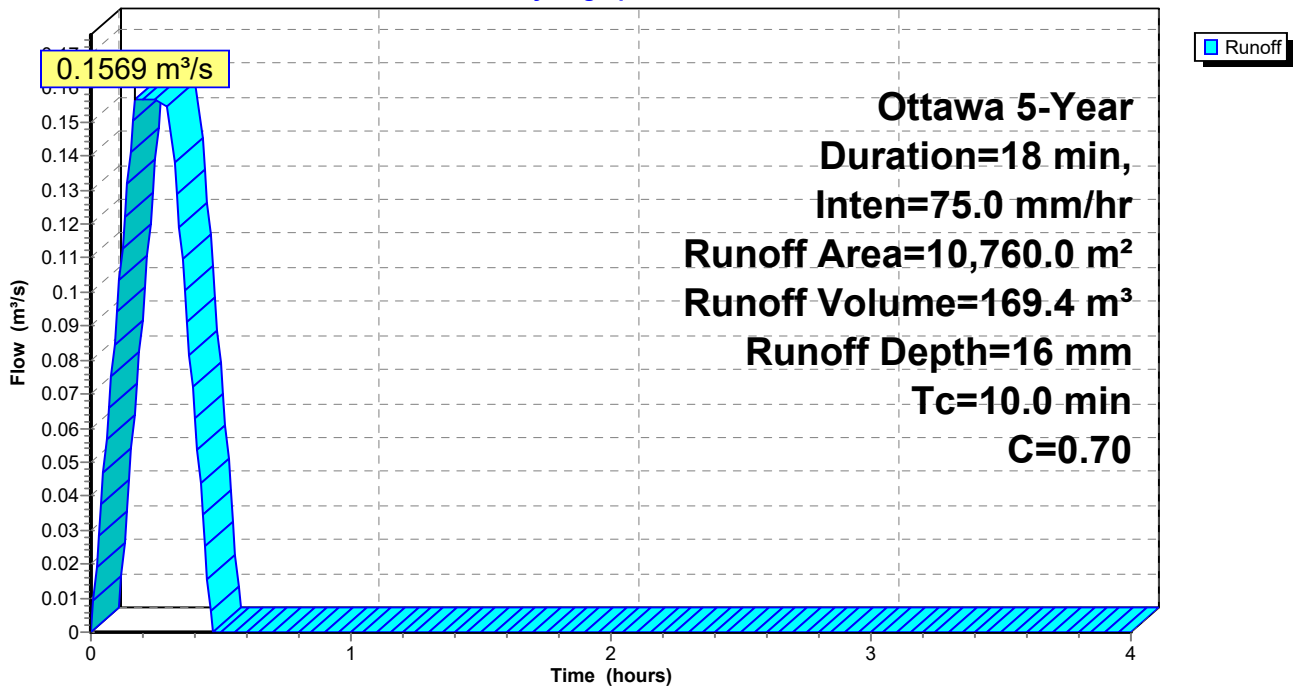



**Summary for Subcatchment 2S: Controlled - Rooftop Storage**

Runoff = 0.0725 m<sup>3</sup>/s @ 0.17 hrs, Volume= 78.3 m<sup>3</sup>, Depth= 20 mm

Runoff by Rational method, Rise/Fall=1.0/1.0 xTc, Time Span= 0.00-4.00 hrs, dt= 0.01 hrs  
 Ottawa 5-Year Duration=18 min, Inten=75.0 mm/hr

Area (m <sup>2</sup> )	C	Description
3,870.0	0.90	A-BLDG
3,870.0		100.00% Pervious Area

Tc (min)	Length (meters)	Slope (m/m)	Velocity (m/sec)	Capacity (m <sup>3</sup> /s)	Description
10.0					Direct Entry,

**Subcatchment 2S: Controlled - Rooftop Storage**

Hydrograph

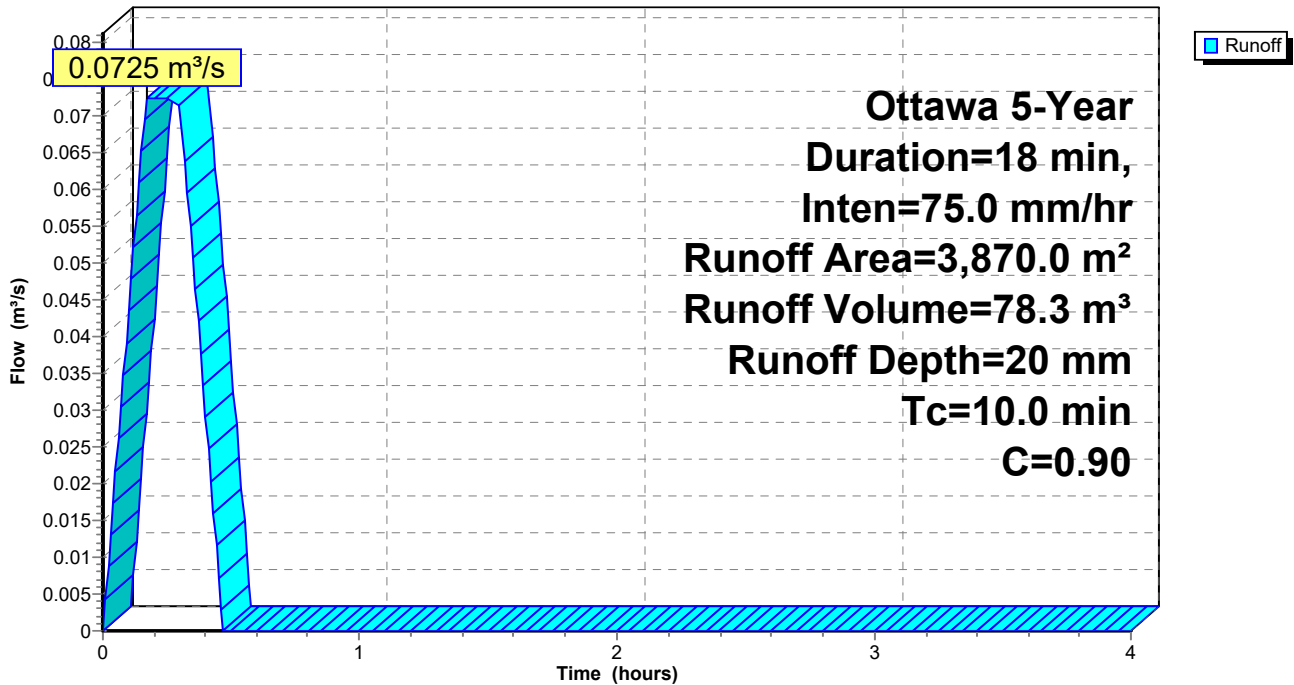

**Summary for Subcatchment 3S: Uncontrolled Site Areas**

Runoff = 0.0189 m³/s @ 0.30 hrs, Volume= 20.3 m³, Depth= 6 mm

Runoff by Rational method, Rise/Fall=1.0/1.0 xTc, Time Span= 0.00-4.00 hrs, dt= 0.01 hrs  
 Ottawa 5-Year Duration=18 min, Inten=75.0 mm/hr

Area (m²)	C	Description
200.0	0.31	A-111
110.0	0.33	A-112
110.0	0.33	A-113
2,440.0	0.26	A-108a
350.0	0.24	A-109a
140.0	0.35	A-110
3,350.0	0.27	Weighted Average
3,350.0		100.00% Pervious Area

Tc (min)	Length (meters)	Slope (m/m)	Velocity (m/sec)	Capacity (m³/s)	Description
17.2					Direct Entry,

**Subcatchment 3S: Uncontrolled Site Areas**

Hydrograph

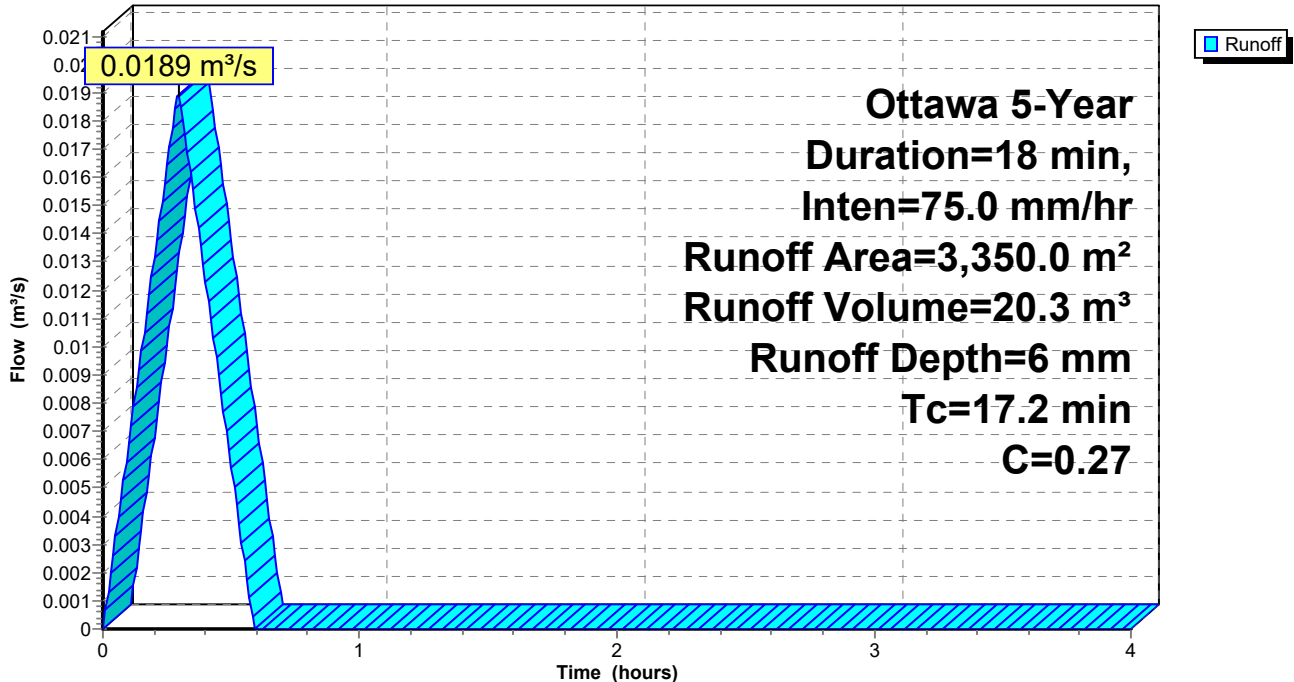

**Summary for Subcatchment 4S: Undeveloped (Bypass Controls)**

Runoff = 0.0538 m<sup>3</sup>/s @ 0.17 hrs, Volume= 58.1 m<sup>3</sup>, Depth= 4 mm

Runoff by Rational method, Rise/Fall=1.0/1.0 xTc, Time Span= 0.00-4.00 hrs, dt= 0.01 hrs  
 Ottawa 5-Year Duration=18 min, Inten=75.0 mm/hr

Area (m <sup>2</sup> )	C	Description
8,510.0	0.20	A-EXT1
1,500.0	0.20	A-EXT2
2,780.0	0.20	A-108b
130.0	0.20	A-109b
12,920.0	0.20	Weighted Average
12,920.0		100.00% Pervious Area

Tc (min)	Length (meters)	Slope (m/m)	Velocity (m/sec)	Capacity (m <sup>3</sup> /s)	Description
10.0					Direct Entry,

**Subcatchment 4S: Undeveloped (Bypass Controls)**

Hydrograph

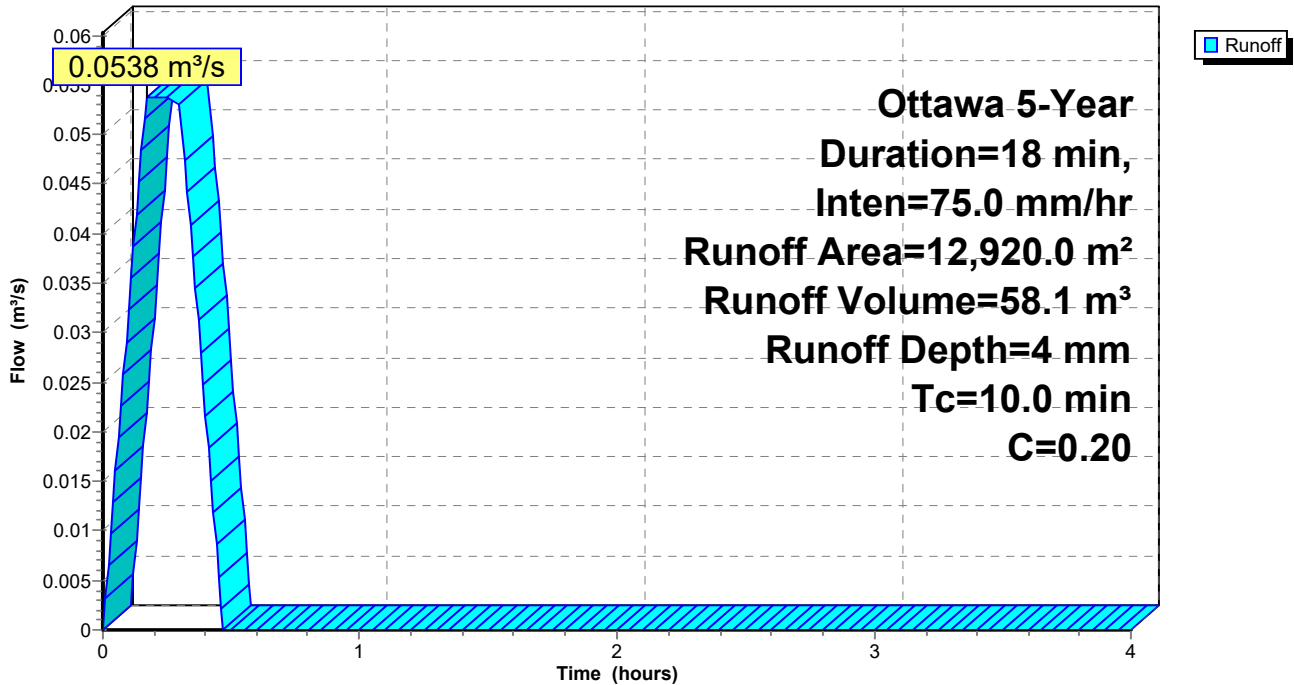

**Summary for Pond 1P: Cistern + Pipe Storage**

Inflow Area = 10,760.0 m<sup>2</sup>, 0.00% Impervious, Inflow Depth = 16 mm for 5-Year event  
 Inflow = 0.1569 m<sup>3</sup>/s @ 0.17 hrs, Volume= 169.4 m<sup>3</sup>  
 Outflow = 0.0166 m<sup>3</sup>/s @ 0.45 hrs, Volume= 156.6 m<sup>3</sup>, Atten= 89%, Lag= 16.7 min  
 Primary = 0.0166 m<sup>3</sup>/s @ 0.45 hrs, Volume= 156.6 m<sup>3</sup>  
 Secondary = 0.0000 m<sup>3</sup>/s @ 0.00 hrs, Volume= 0.0 m<sup>3</sup>

Routing by Stor-Ind method, Time Span= 0.00-4.00 hrs, dt= 0.01 hrs  
 Peak Elev= 103.501 m @ 0.45 hrs Surf.Area= 547.8 m<sup>2</sup> Storage= 151.8 m<sup>3</sup>

Plug-Flow detention time= 90.6 min calculated for 156.2 m<sup>3</sup> (92% of inflow)  
 Center-of-Mass det. time= 90.1 min ( 104.1 - 14.0 )

Volume	Invert	Avail.Storage	Storage Description
#1	103.218 m	461.6 m <sup>3</sup>	<b>10.00 mW x 53.06 mL x 0.87 mH Cistern</b>
#2	103.218 m	0.2 m <sup>3</sup>	<b>450 mm Round Pipe Storage</b> L= 1.55 m
#3	103.371 m	3.4 m <sup>3</sup>	<b>300 mm Round Pipe Storage</b> L= 47.40 m
#4	103.421 m	0.5 m <sup>3</sup>	<b>250 mm Round Pipe Storage</b> L= 10.45 m
		465.7 m <sup>3</sup>	Total Available Storage

Device	Routing	Invert	Outlet Devices
#1	Secondary	104.085 m	<b>***Overflow Check</b> Head (meters) 0.000 0.010 Disch. (m <sup>3</sup> /s) 0.00000 10.00000
#2	Primary	103.154 m	<b>122 mm Vert. Orifice/Grate</b> C= 0.600

**Primary OutFlow** Max=0.0166 m<sup>3</sup>/s @ 0.45 hrs HW=103.501 m (Free Discharge)  
 ↑**2=Orifice/Grate** (Orifice Controls 0.0166 m<sup>3</sup>/s @ 1.42 m/s)

**Secondary OutFlow** Max=0.0000 m<sup>3</sup>/s @ 0.00 hrs HW=103.218 m (Free Discharge)  
 ↑**1=\*\*\*Overflow Check** ( Controls 0.0000 m<sup>3</sup>/s)

### Pond 1P: Cistern + Pipe Storage

Hydrograph

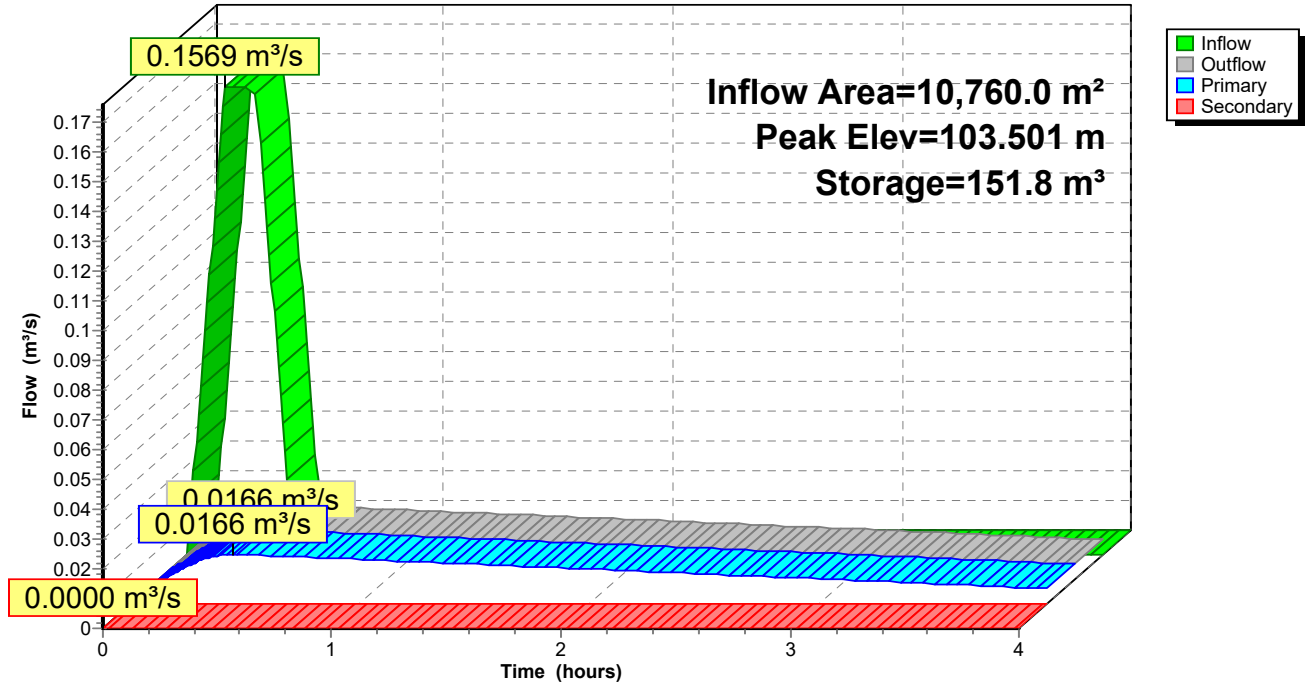

**Summary for Pond 2P: Rooftop Storage**

Inflow Area = 3,870.0 m<sup>2</sup>, 0.00% Impervious, Inflow Depth = 20 mm for 5-Year event  
 Inflow = 0.0725 m<sup>3</sup>/s @ 0.17 hrs, Volume= 78.3 m<sup>3</sup>  
 Outflow = 0.0079 m<sup>3</sup>/s @ 0.45 hrs, Volume= 77.9 m<sup>3</sup>, Atten= 89%, Lag= 16.7 min  
 Primary = 0.0079 m<sup>3</sup>/s @ 0.45 hrs, Volume= 77.9 m<sup>3</sup>

Routing by Stor-Ind method, Time Span= 0.00-4.00 hrs, dt= 0.01 hrs  
 Peak Elev= 100.108 m @ 0.45 hrs Surf.Area= 1,918.4 m<sup>2</sup> Storage= 69.1 m<sup>3</sup>

Plug-Flow detention time= 88.8 min calculated for 77.8 m<sup>3</sup> (99% of inflow)  
 Center-of-Mass det. time= 89.1 min ( 103.1 - 14.0 )

Volume	Invert	Avail.Storage	Storage Description	
#1	100.000 m	192.2 m <sup>3</sup>	<b>Custom Stage Data (Pyramidal)</b> Listed below (Recalc)	
Elevation (meters)	Surf.Area (sq-meters)	Inc.Store (cubic-meters)	Cum.Store (cubic-meters)	Wet.Area (sq-meters)
100.000	0.0	0.0	0.0	0.0
100.152	3,794.0	192.2	192.2	3,794.0

Device	Routing	Invert	Outlet Devices
#1	Primary	100.000 m	<b>Special &amp; User-Defined X 7.00</b> Head (meters) 0.000 0.152 Disch. (m <sup>3</sup> /s) 0.00000 0.00158

**Primary OutFlow** Max=0.0079 m<sup>3</sup>/s @ 0.45 hrs HW=100.108 m (Free Discharge)  
 ↑1=Special & User-Defined (Custom Controls 0.0079 m<sup>3</sup>/s)

### Pond 2P: Rooftop Storage

Hydrograph

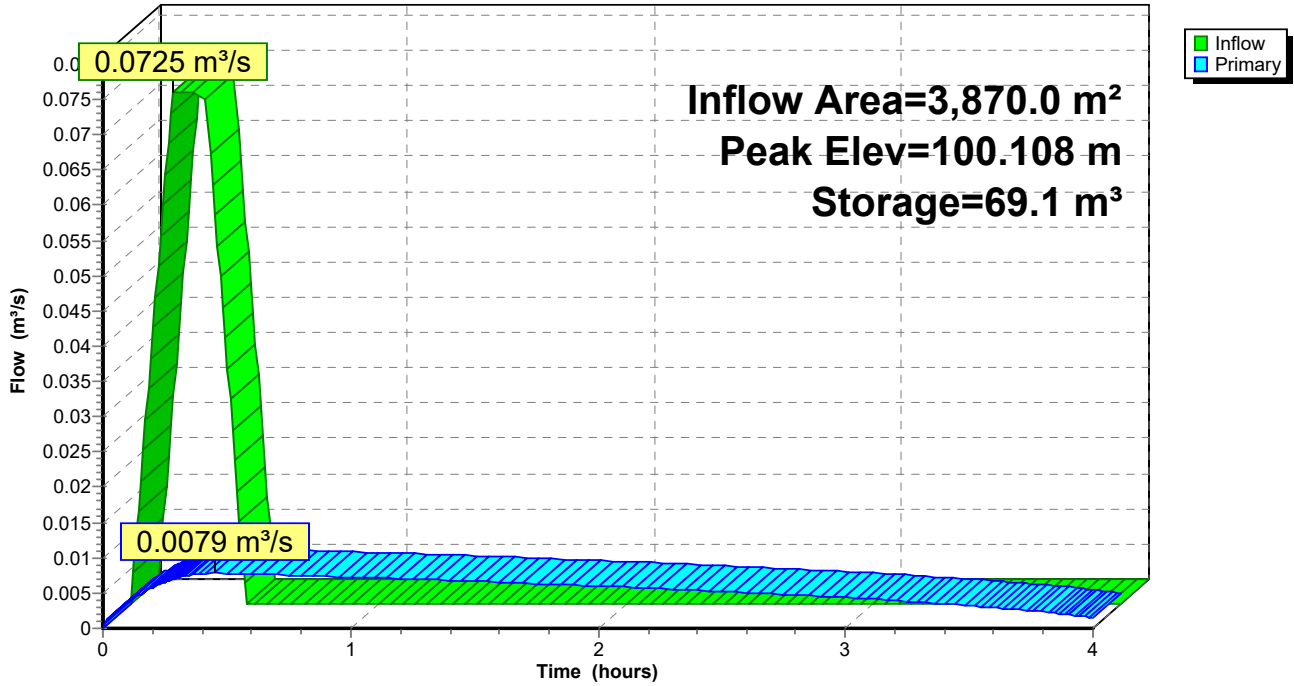

### Summary for Link 1L: Site Release

Inflow Area = 17,980.0 m<sup>2</sup>, 0.00% Impervious, Inflow Depth > 14 mm for 5-Year event  
Inflow = 0.0404 m<sup>3</sup>/s @ 0.30 hrs, Volume= 254.9 m<sup>3</sup>  
Primary = 0.0404 m<sup>3</sup>/s @ 0.30 hrs, Volume= 254.9 m<sup>3</sup>, Atten= 0%, Lag= 0.0 min

Primary outflow = Inflow, Time Span= 0.00-4.00 hrs, dt= 0.01 hrs

### Link 1L: Site Release

Hydrograph

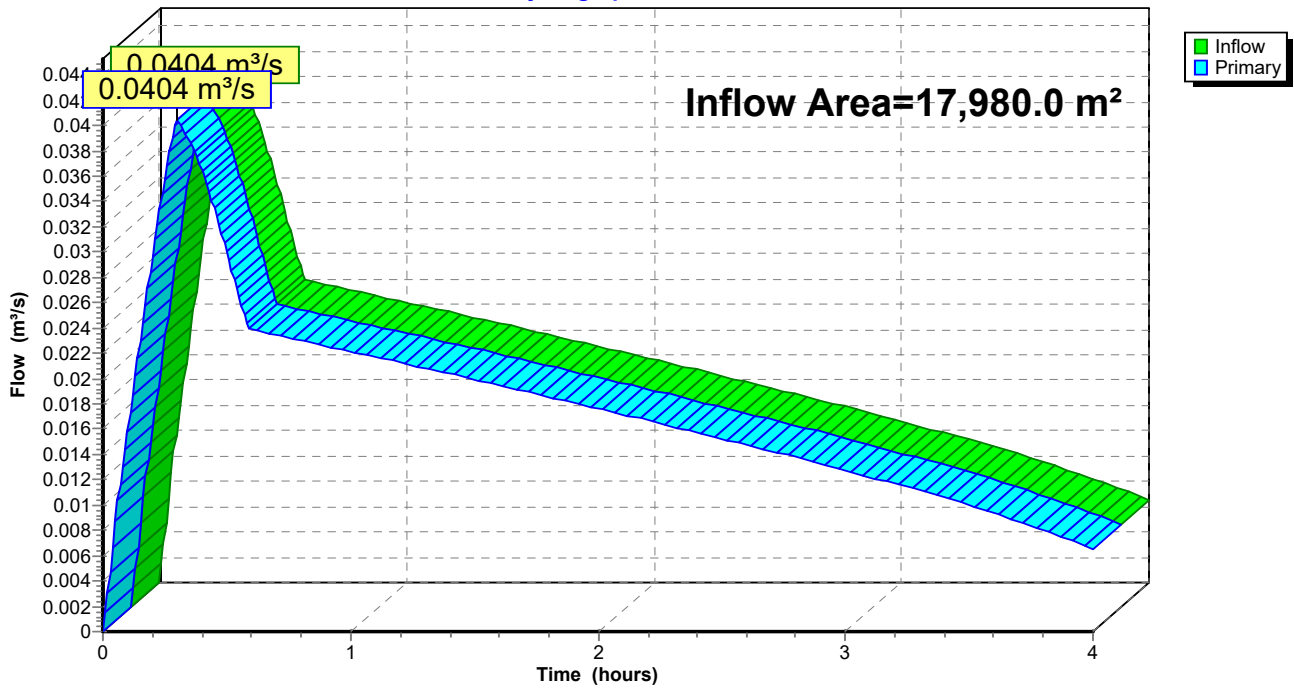



### Summary for Link 2L: Undeveloped Areas Directed Downstream of Controls

Inflow Area = 12,920.0 m<sup>2</sup>, 0.00% Impervious, Inflow Depth = 4 mm for 5-Year event  
Inflow = 0.0538 m<sup>3</sup>/s @ 0.17 hrs, Volume= 58.1 m<sup>3</sup>  
Primary = 0.0538 m<sup>3</sup>/s @ 0.17 hrs, Volume= 58.1 m<sup>3</sup>, Atten= 0%, Lag= 0.0 min

Primary outflow = Inflow, Time Span= 0.00-4.00 hrs, dt= 0.01 hrs

### Link 2L: Undeveloped Areas Directed Downstream of Controls

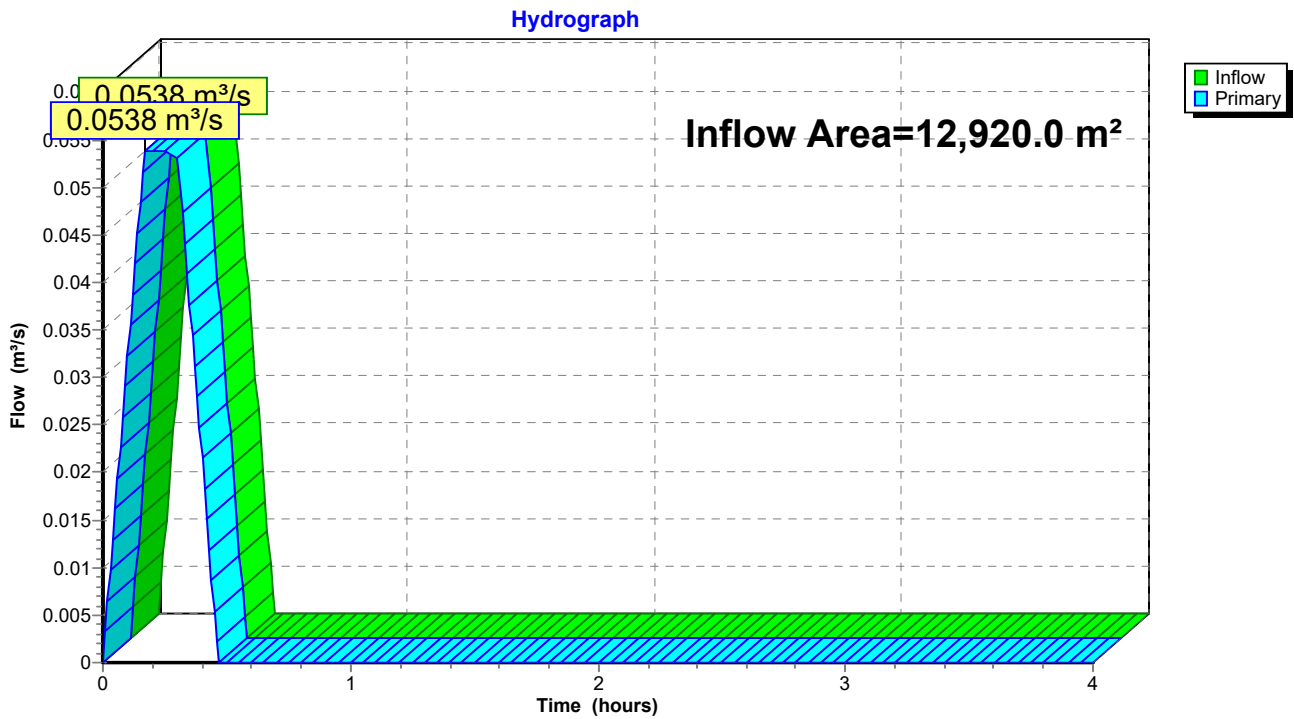

### Summary for Link 4L: Total Site Outflow

Inflow Area = 30,900.0 m<sup>2</sup>, 0.00% Impervious, Inflow Depth > 10 mm for 5-Year event  
Inflow = 0.0945 m<sup>3</sup>/s @ 0.30 hrs, Volume= 313.0 m<sup>3</sup>  
Primary = 0.0945 m<sup>3</sup>/s @ 0.30 hrs, Volume= 313.0 m<sup>3</sup>, Atten= 0%, Lag= 0.0 min

Primary outflow = Inflow, Time Span= 0.00-4.00 hrs, dt= 0.01 hrs

### Link 4L: Total Site Outflow

Hydrograph

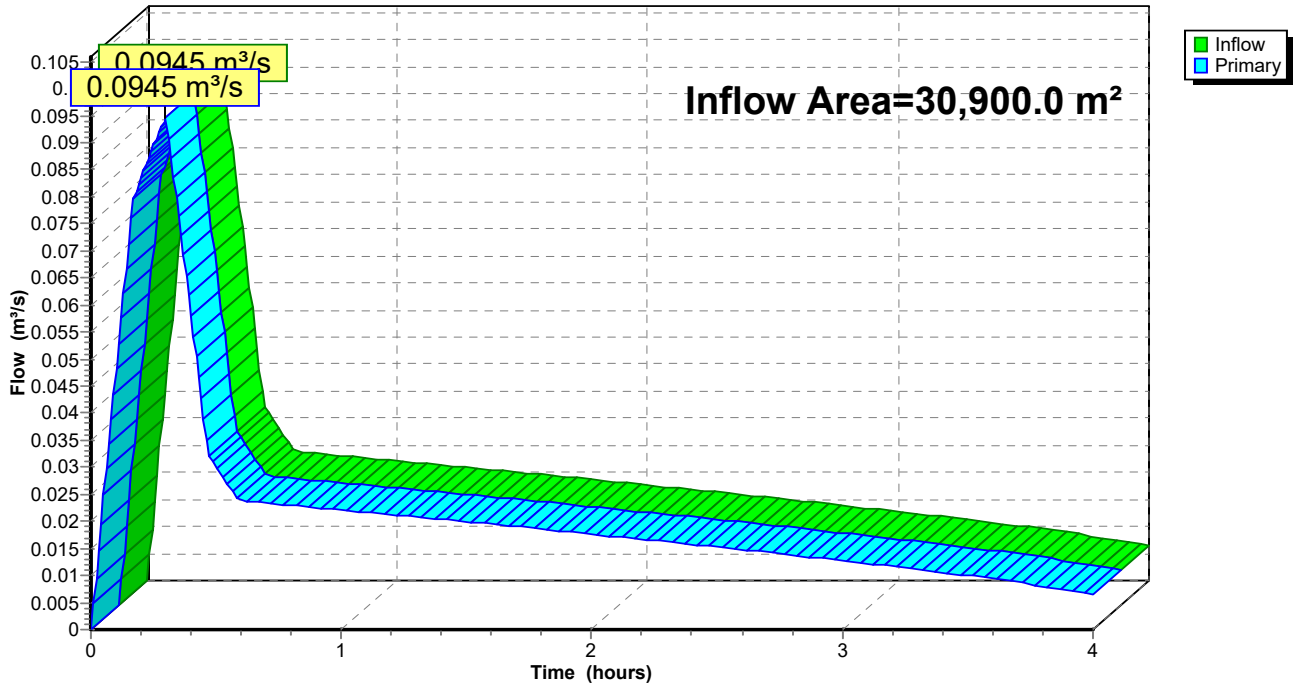

**6301 Campeu Drive  
Parcel 1**

100-year C      Peak Discharge (Td = 18 min)

Cistern Controlled

Controlled Building  
Areas with Rooftop  
Storage

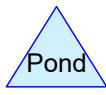
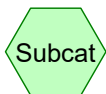
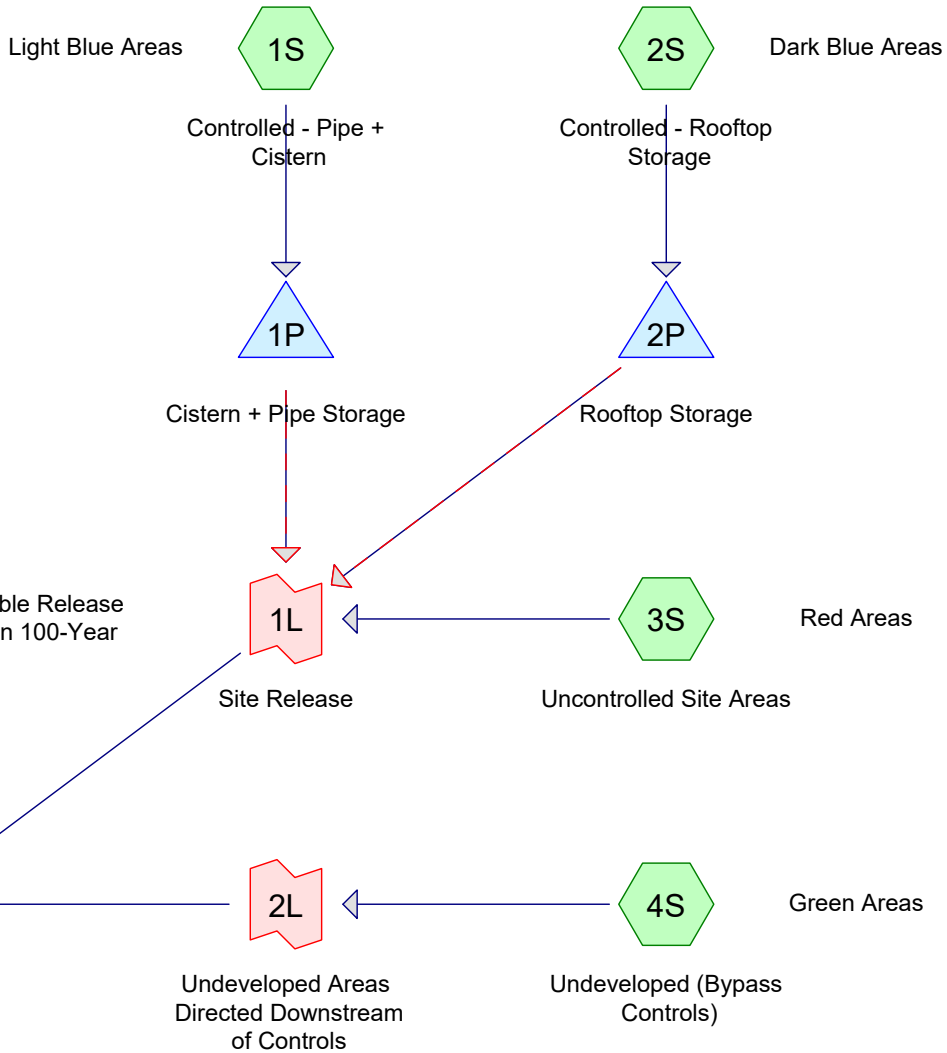

# CampeauDrive\_Parcel 1 100-yr

Prepared by WSP Canada inc.

HydroCAD® 10.00-21 s/n 10060 © 2018 HydroCAD Software Solutions LLC

Printed 2021-05-27

Page 2

## Area Listing (all nodes)

Area (sq-meters)	C	Description (subcatchment-numbers)
2,140.0	0.93	A-101 (1S)
1,990.0	1.00	A-102 (1S)
2,230.0	1.00	A-103 (1S)
1,770.0	1.00	A-104 (1S)
540.0	0.31	A-105 (1S)
700.0	0.30	A-106 (1S)
150.0	1.00	A-107 (1S)
2,440.0	0.33	A-108a (3S)
2,780.0	0.25	A-108b (4S)
350.0	0.30	A-109a (3S)
130.0	0.25	A-109b (4S)
140.0	0.44	A-110 (3S)
200.0	0.38	A-111 (3S)
110.0	0.41	A-112 (3S)
110.0	0.41	A-113 (3S)
3,870.0	1.00	A-BLDG (2S)
8,510.0	0.25	A-EXT1 (4S)
1,500.0	0.25	A-EXT2 (4S)
1,240.0	0.56	A-EXT3 (1S)
<b>30,900.0</b>	<b>0.56</b>	<b>TOTAL AREA</b>

**Summary for Subcatchment 1S: Controlled - Pipe + Cistern**

Runoff = 0.0899 m³/s @ 0.17 hrs, Volume= 598.4 m³, Depth= 56 mm

Runoff by Rational method, Rise/Fall=1.0/1.0 xTc, Time Span= 0.00-4.00 hrs, dt= 0.01 hrs  
 Ottawa 100-Year Duration=111 min, Inten=35.0 mm/hr

Area (m²)	C	Description
2,140.0	0.93	A-101
1,990.0	1.00	A-102
2,230.0	1.00	A-103
1,770.0	1.00	A-104
540.0	0.31	A-105
700.0	0.30	A-106
150.0	1.00	A-107
1,240.0	0.56	A-EXT3
10,760.0	0.86	Weighted Average
4,620.0		42.94% Pervious Area
6,140.0		57.06% Impervious Area

Tc (min)	Length (meters)	Slope (m/m)	Velocity (m/sec)	Capacity (m³/s)	Description
10.0					Direct Entry,

**Subcatchment 1S: Controlled - Pipe + Cistern**

Hydrograph

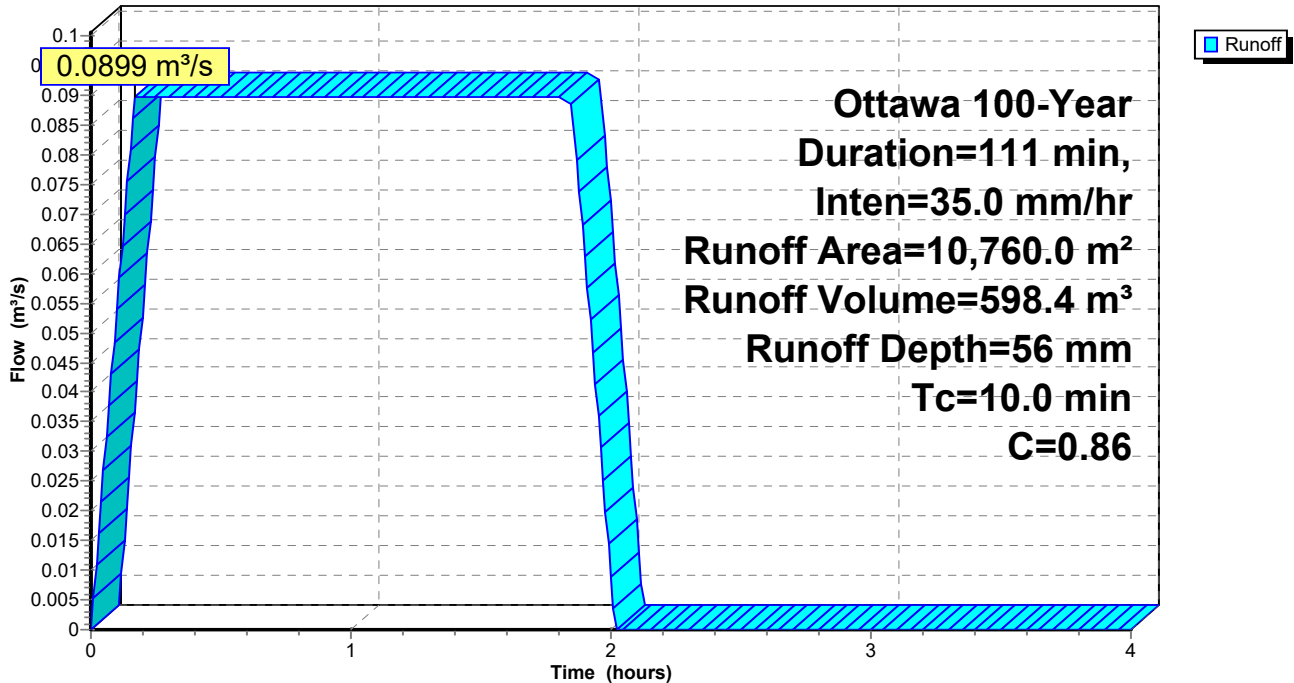

**Summary for Subcatchment 2S: Controlled - Rooftop Storage**

Runoff = 0.0376 m<sup>3</sup>/s @ 0.17 hrs, Volume= 250.3 m<sup>3</sup>, Depth= 65 mm

Runoff by Rational method, Rise/Fall=1.0/1.0 xTc, Time Span= 0.00-4.00 hrs, dt= 0.01 hrs  
 Ottawa 100-Year Duration=111 min, Inten=35.0 mm/hr

Area (m <sup>2</sup> )	C	Description
3,870.0	1.00	A-BLDG
3,870.0		100.00% Impervious Area

Tc (min)	Length (meters)	Slope (m/m)	Velocity (m/sec)	Capacity (m <sup>3</sup> /s)	Description
10.0					Direct Entry,

**Subcatchment 2S: Controlled - Rooftop Storage**

Hydrograph

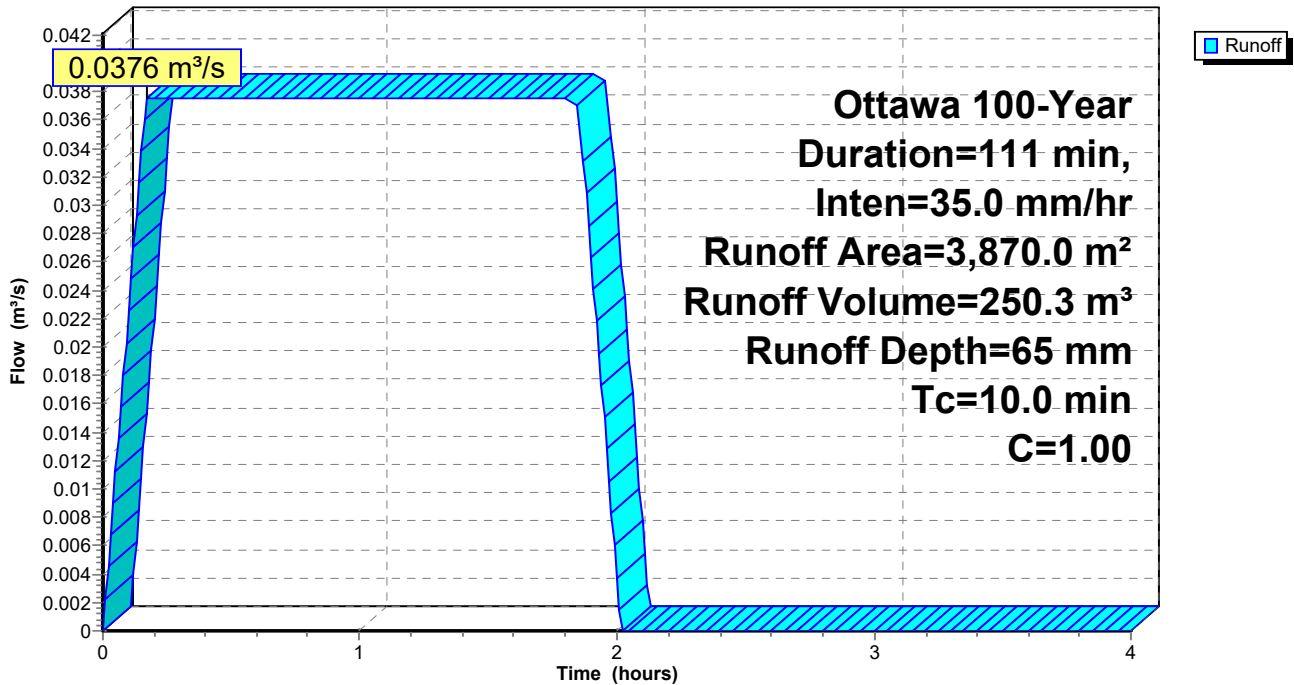

**Summary for Subcatchment 3S: Uncontrolled Site Areas**

Runoff = 0.0111 m³/s @ 0.29 hrs, Volume= 73.7 m³, Depth= 22 mm

Runoff by Rational method, Rise/Fall=1.0/1.0 xTc, Time Span= 0.00-4.00 hrs, dt= 0.01 hrs  
 Ottawa 100-Year Duration=111 min, Inten=35.0 mm/hr

Area (m²)	C	Description
200.0	0.38	A-111
110.0	0.41	A-112
110.0	0.41	A-113
2,440.0	0.33	A-108a
350.0	0.30	A-109a
140.0	0.44	A-110
3,350.0	0.34	Weighted Average
3,350.0		100.00% Pervious Area

Tc (min)	Length (meters)	Slope (m/m)	Velocity (m/sec)	Capacity (m³/s)	Description
17.2					Direct Entry,

**Subcatchment 3S: Uncontrolled Site Areas**

Hydrograph

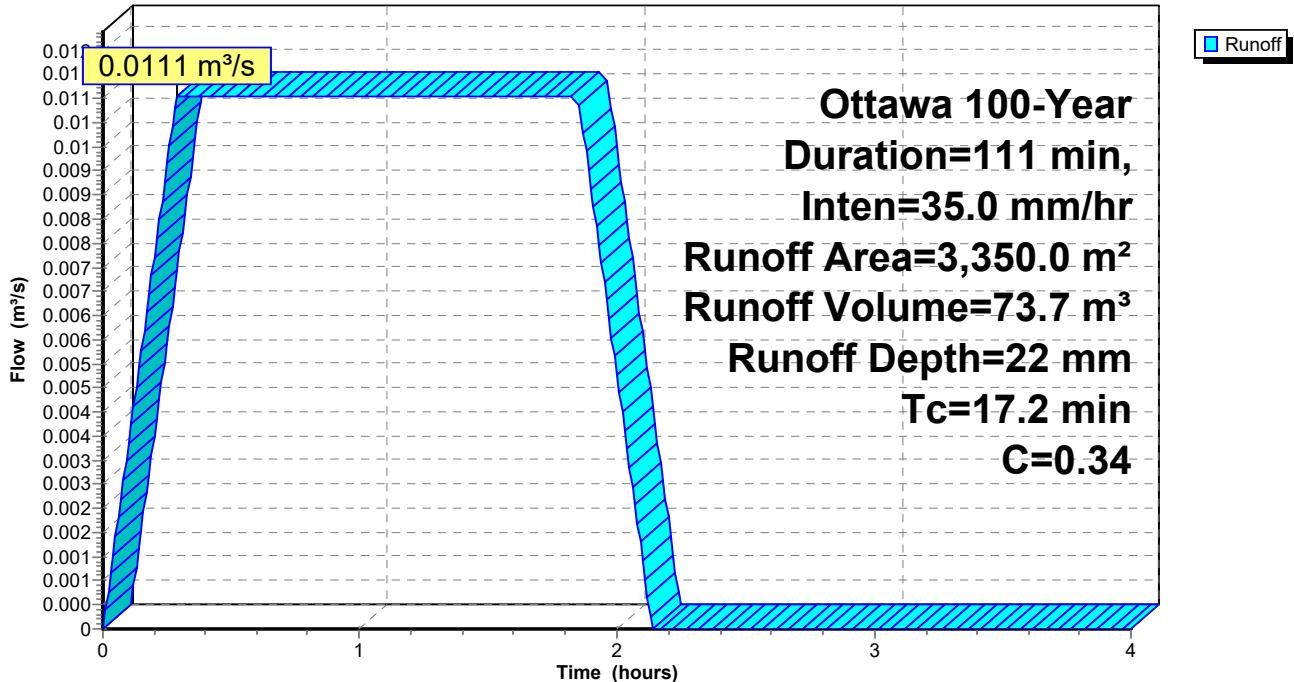

**Summary for Subcatchment 4S: Undeveloped (Bypass Controls)**

Runoff = 0.0314 m³/s @ 0.29 hrs, Volume= 208.9 m³, Depth= 16 mm

Runoff by Rational method, Rise/Fall=1.0/1.0 xTc, Time Span= 0.00-4.00 hrs, dt= 0.01 hrs  
 Ottawa 100-Year Duration=111 min, Inten=35.0 mm/hr

Area (m²)	C	Description
8,510.0	0.25	A-EXT1
1,500.0	0.25	A-EXT2
2,780.0	0.25	A-108b
130.0	0.25	A-109b
12,920.0	0.25	Weighted Average
12,920.0		100.00% Pervious Area

Tc (min)	Length (meters)	Slope (m/m)	Velocity (m/sec)	Capacity (m³/s)	Description
17.2					Direct Entry,

**Subcatchment 4S: Undeveloped (Bypass Controls)**

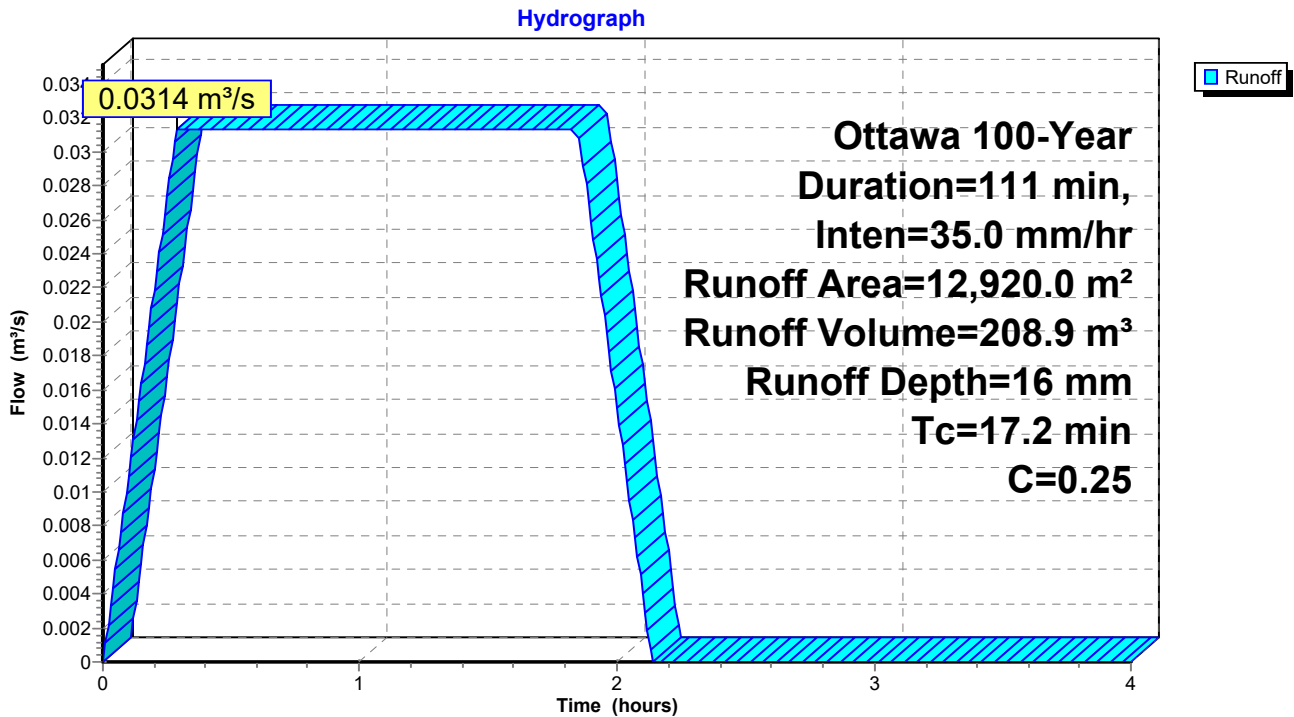



**Summary for Pond 1P: Cistern + Pipe Storage**

Inflow Area = 10,760.0 m<sup>2</sup>, 57.06% Impervious, Inflow Depth = 56 mm for 100-Year event  
 Inflow = 0.0899 m<sup>3</sup>/s @ 0.17 hrs, Volume= 598.4 m<sup>3</sup>  
 Outflow = 0.0288 m<sup>3</sup>/s @ 1.96 hrs, Volume= 324.6 m<sup>3</sup>, Atten= 68%, Lag= 107.6 min  
 Primary = 0.0288 m<sup>3</sup>/s @ 1.96 hrs, Volume= 324.6 m<sup>3</sup>  
 Secondary = 0.0000 m<sup>3</sup>/s @ 0.00 hrs, Volume= 0.0 m<sup>3</sup>

Routing by Stor-Ind method, Time Span= 0.00-4.00 hrs, dt= 0.01 hrs  
 Peak Elev= 104.075 m @ 1.96 hrs Surf.Area= 530.6 m<sup>2</sup> Storage= 458.9 m<sup>3</sup>

Plug-Flow detention time= 97.2 min calculated for 324.6 m<sup>3</sup> (54% of inflow)  
 Center-of-Mass det. time= 71.7 min ( 132.2 - 60.5 )

Volume	Invert	Avail.Storage	Storage Description
#1	103.218 m	461.6 m <sup>3</sup>	<b>10.00 mW x 53.06 mL x 0.87 mH Cistern</b>
#2	103.218 m	0.2 m <sup>3</sup>	<b>450 mm Round Pipe Storage</b> L= 1.55 m
#3	103.371 m	3.4 m <sup>3</sup>	<b>300 mm Round Pipe Storage</b> L= 47.40 m
#4	103.421 m	0.5 m <sup>3</sup>	<b>250 mm Round Pipe Storage</b> L= 10.45 m
		465.7 m <sup>3</sup>	Total Available Storage

Device	Routing	Invert	Outlet Devices
#1	Secondary	104.085 m	<b>***Overflow Check</b> Head (meters) 0.000 0.010 Disch. (m <sup>3</sup> /s) 0.00000 10.00000
#2	Primary	103.154 m	<b>122 mm Vert. Orifice/Grate</b> C= 0.600

**Primary OutFlow** Max=0.0288 m<sup>3</sup>/s @ 1.96 hrs HW=104.075 m (Free Discharge)  
 ↑**2=Orifice/Grate** (Orifice Controls 0.0288 m<sup>3</sup>/s @ 2.46 m/s)

**Secondary OutFlow** Max=0.0000 m<sup>3</sup>/s @ 0.00 hrs HW=103.218 m (Free Discharge)  
 ↑**1=\*\*\*Overflow Check** ( Controls 0.0000 m<sup>3</sup>/s)

### Pond 1P: Cistern + Pipe Storage

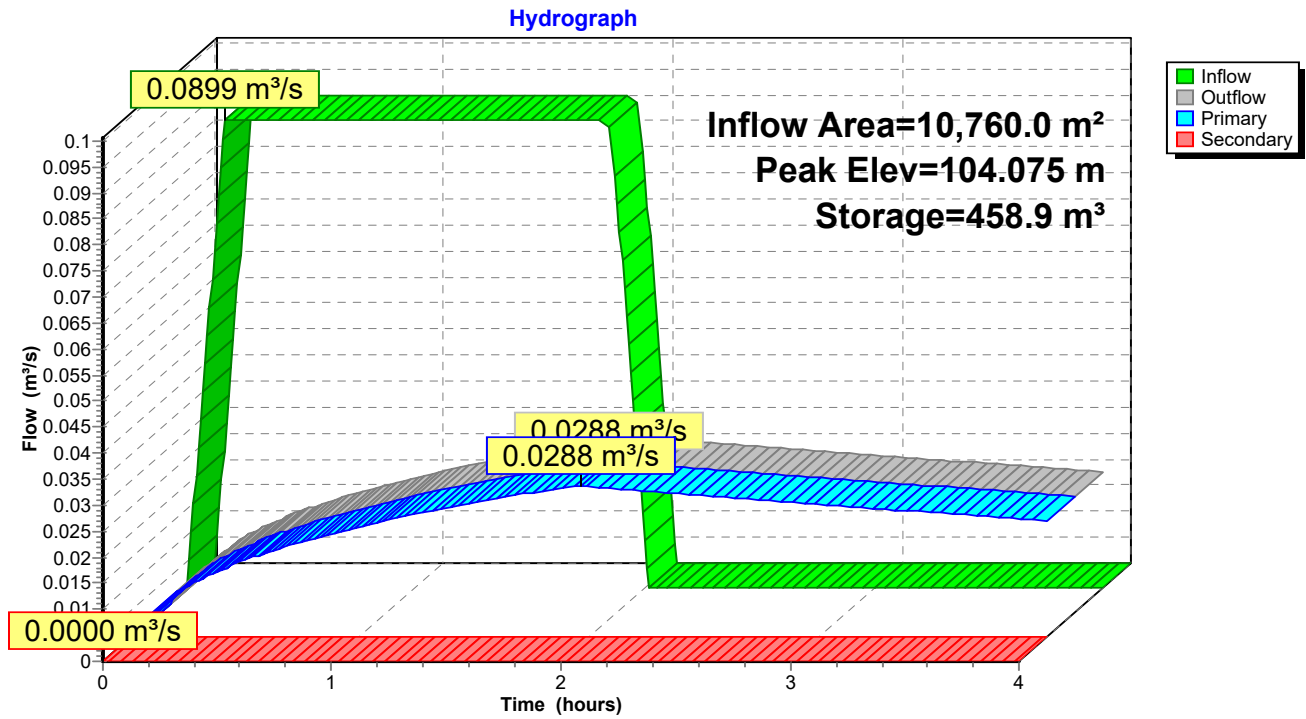

**Summary for Pond 2P: Rooftop Storage**

Inflow Area = 3,870.0 m<sup>2</sup>, 100.00% Impervious, Inflow Depth = 65 mm for 100-Year event  
 Inflow = 0.0376 m<sup>3</sup>/s @ 0.17 hrs, Volume= 250.3 m<sup>3</sup>  
 Outflow = 0.0110 m<sup>3</sup>/s @ 1.97 hrs, Volume= 133.2 m<sup>3</sup>, Atten= 71%, Lag= 107.9 min  
 Primary = 0.0110 m<sup>3</sup>/s @ 1.97 hrs, Volume= 133.2 m<sup>3</sup>

Routing by Stor-Ind method, Time Span= 0.00-4.00 hrs, dt= 0.01 hrs  
 Peak Elev= 100.152 m @ 1.97 hrs Surf.Area= 3,779.3 m<sup>2</sup> Storage= 191.1 m<sup>3</sup>

Plug-Flow detention time= 95.3 min calculated for 132.9 m<sup>3</sup> (53% of inflow)  
 Center-of-Mass det. time= 69.5 min ( 130.0 - 60.5 )

Volume	Invert	Avail.Storage	Storage Description	
#1	100.000 m	192.2 m <sup>3</sup>	<b>Custom Stage Data (Pyramidal)</b> Listed below (Recalc)	
Elevation (meters)	Surf.Area (sq-meters)	Inc.Store (cubic-meters)	Cum.Store (cubic-meters)	Wet.Area (sq-meters)
100.000	0.0	0.0	0.0	0.0
100.152	3,794.0	192.2	192.2	3,794.0

Device	Routing	Invert	Outlet Devices
#1	Primary	100.000 m	<b>Special &amp; User-Defined X 7.00</b> Head (meters) 0.000 0.152 Disch. (m <sup>3</sup> /s) 0.00000 0.00158

**Primary OutFlow** Max=0.0110 m<sup>3</sup>/s @ 1.97 hrs HW=100.152 m (Free Discharge)  
 ↑1=Special & User-Defined (Custom Controls 0.0110 m<sup>3</sup>/s)

### Pond 2P: Rooftop Storage

Hydrograph

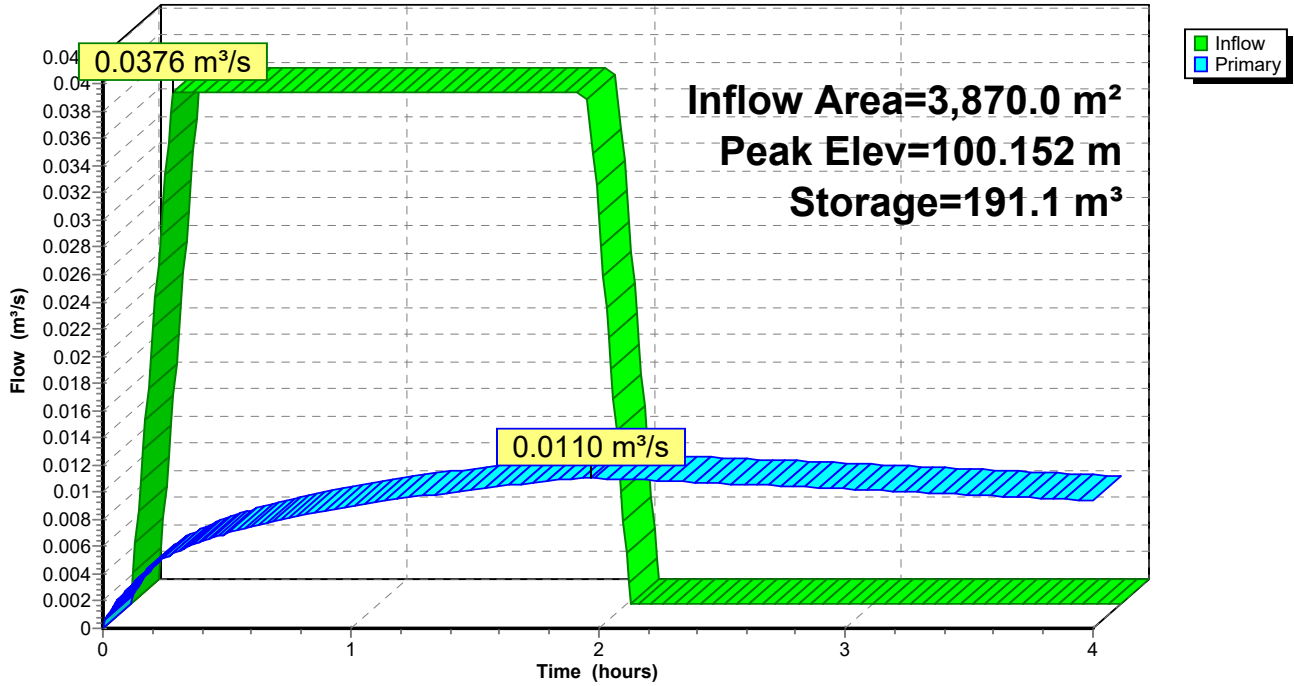

### Summary for Link 1L: Site Release

Inflow Area = 17,980.0 m<sup>2</sup>, 55.67% Impervious, Inflow Depth > 30 mm for 100-Year event  
Inflow = 0.0504 m<sup>3</sup>/s @ 1.85 hrs, Volume= 531.5 m<sup>3</sup>  
Primary = 0.0504 m<sup>3</sup>/s @ 1.85 hrs, Volume= 531.5 m<sup>3</sup>, Atten= 0%, Lag= 0.0 min

Primary outflow = Inflow, Time Span= 0.00-4.00 hrs, dt= 0.01 hrs

### Link 1L: Site Release

Hydrograph

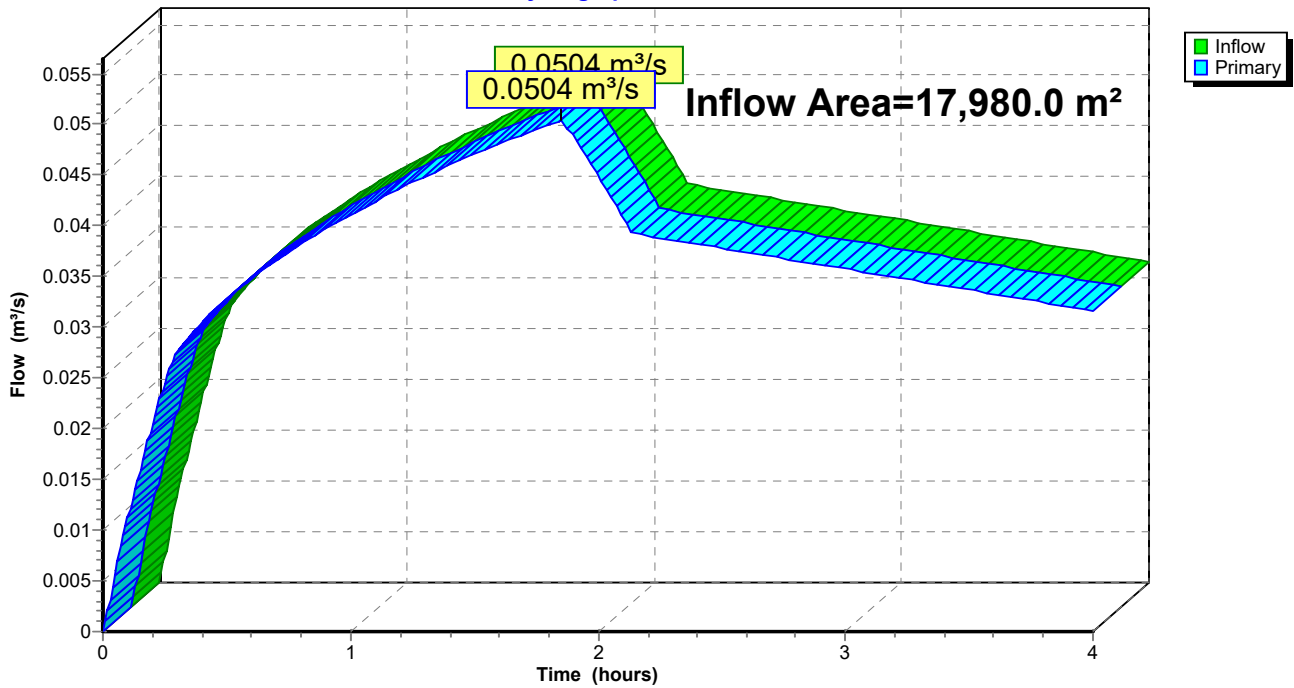

### Summary for Link 2L: Undeveloped Areas Directed Downstream of Controls

Inflow Area = 12,920.0 m<sup>2</sup>, 0.00% Impervious, Inflow Depth = 16 mm for 100-Year event  
Inflow = 0.0314 m<sup>3</sup>/s @ 0.29 hrs, Volume= 208.9 m<sup>3</sup>  
Primary = 0.0314 m<sup>3</sup>/s @ 0.29 hrs, Volume= 208.9 m<sup>3</sup>, Atten= 0%, Lag= 0.0 min

Primary outflow = Inflow, Time Span= 0.00-4.00 hrs, dt= 0.01 hrs

### Link 2L: Undeveloped Areas Directed Downstream of Controls

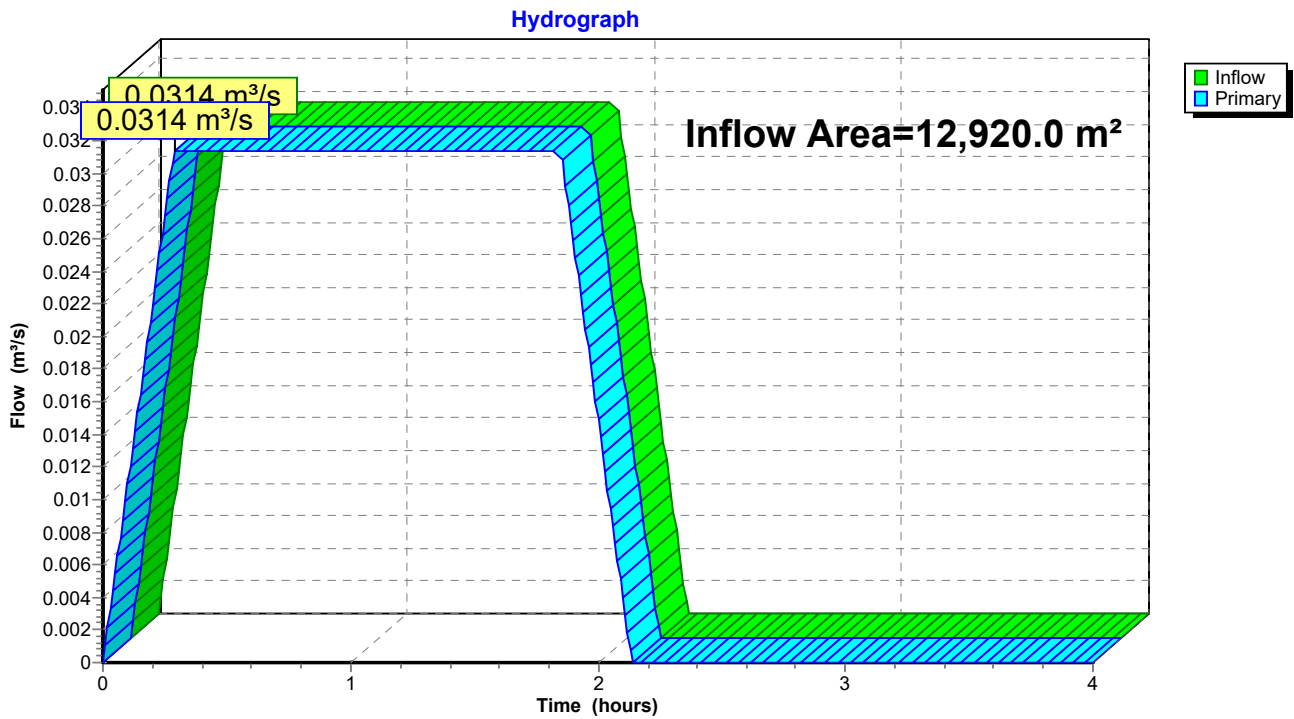

### Summary for Link 4L: Total Site Outflow

Inflow Area = 30,900.0 m<sup>2</sup>, 32.39% Impervious, Inflow Depth > 24 mm for 100-Year event  
Inflow = 0.0819 m<sup>3</sup>/s @ 1.85 hrs, Volume= 740.4 m<sup>3</sup>  
Primary = 0.0819 m<sup>3</sup>/s @ 1.85 hrs, Volume= 740.4 m<sup>3</sup>, Atten= 0%, Lag= 0.0 min

Primary outflow = Inflow, Time Span= 0.00-4.00 hrs, dt= 0.01 hrs

### Link 4L: Total Site Outflow

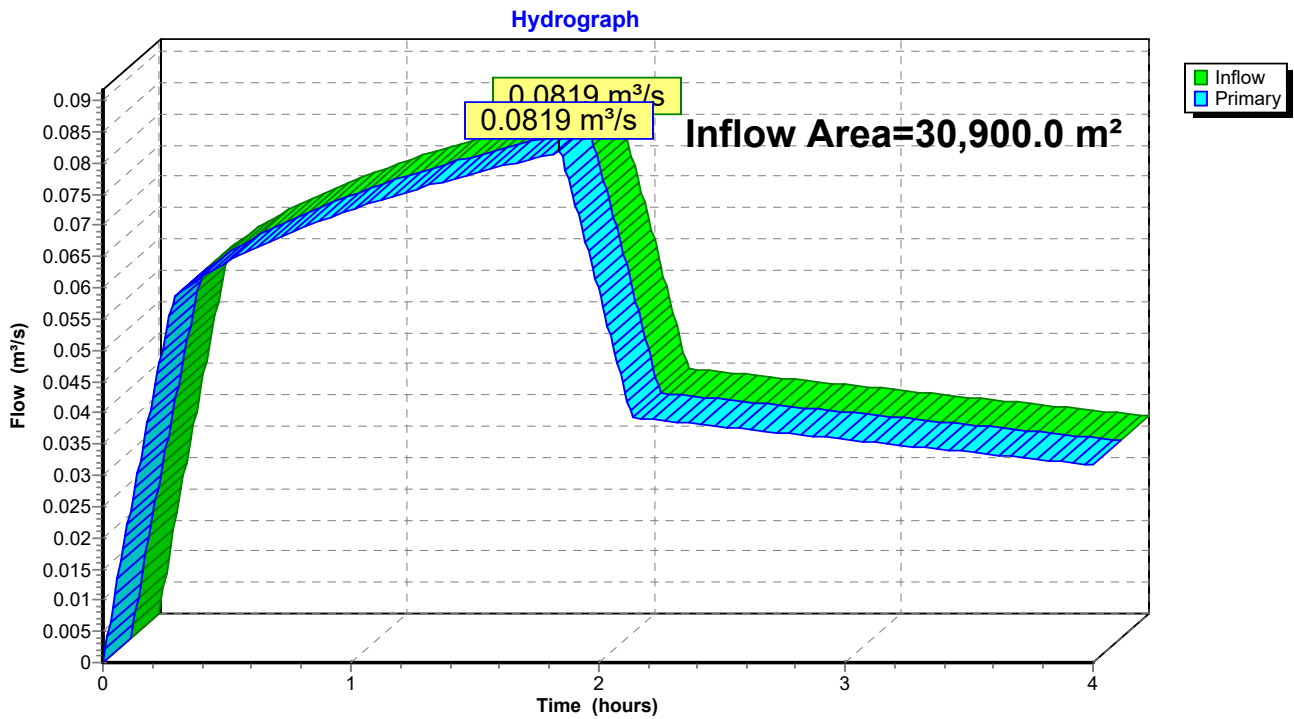

# APPENDIX

## **G-3** Parcel 1: 100-Year Analysis (Peak Storage)

*The storm system for Parcel 1 is governed by the 100-year storm. Peak storage and peak discharge occur at separate storm durations and are therefore reported separately.*



**6301 Campeu Drive  
Parcel 1**

100-year C Peak Storage (Td = 111 min)

Cistern Controlled

Controlled Building  
Areas with Rooftop  
Storage

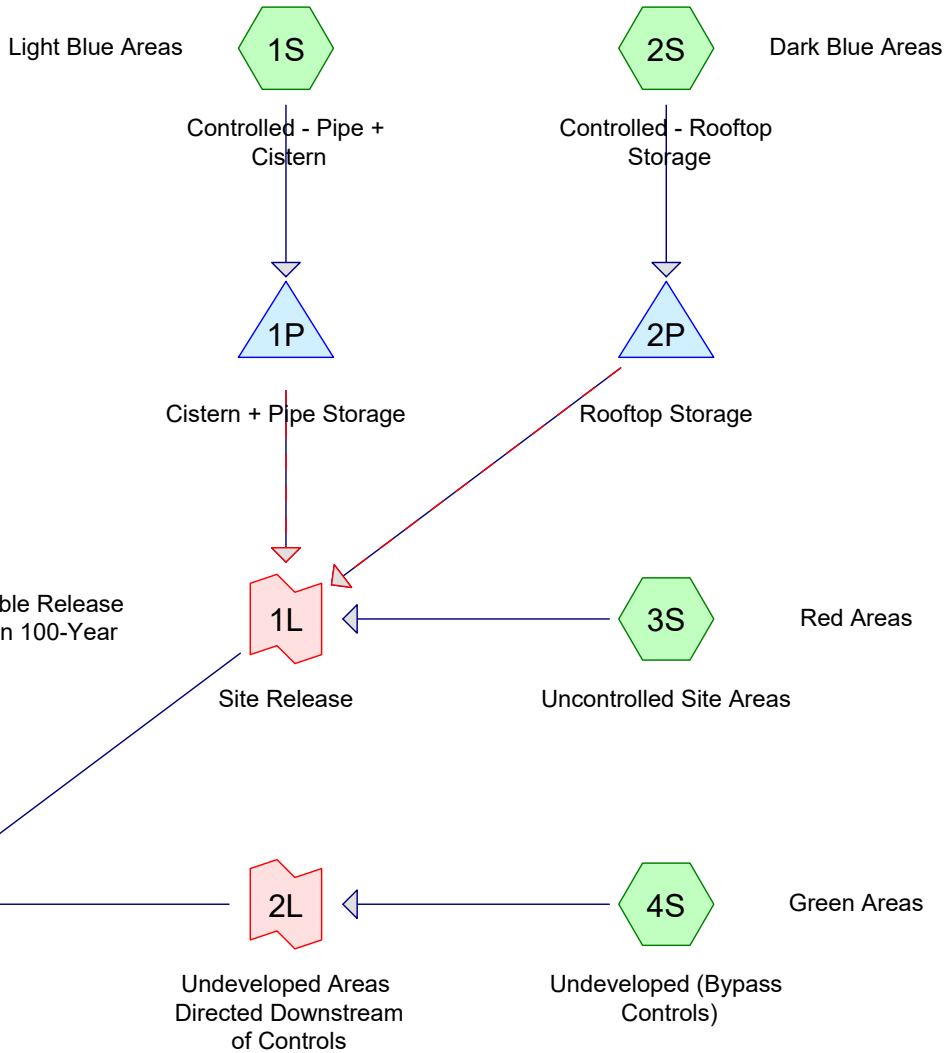

Max Allowable Release  
= 70.3 /s in 100-Year

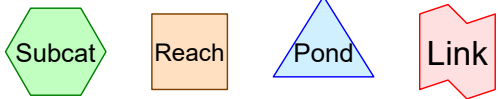

# CampeauDrive\_Parcel 1 100-yr

Prepared by WSP Canada inc.

HydroCAD® 10.00-21 s/n 10060 © 2018 HydroCAD Software Solutions LLC

Printed 2021-05-27

Page 2

## Area Listing (all nodes)

Area (sq-meters)	C	Description (subcatchment-numbers)
2,140.0	0.93	A-101 (1S)
1,990.0	1.00	A-102 (1S)
2,230.0	1.00	A-103 (1S)
1,770.0	1.00	A-104 (1S)
540.0	0.31	A-105 (1S)
700.0	0.30	A-106 (1S)
150.0	1.00	A-107 (1S)
2,440.0	0.33	A-108a (3S)
2,780.0	0.25	A-108b (4S)
350.0	0.30	A-109a (3S)
130.0	0.25	A-109b (4S)
140.0	0.44	A-110 (3S)
200.0	0.38	A-111 (3S)
110.0	0.41	A-112 (3S)
110.0	0.41	A-113 (3S)
3,870.0	1.00	A-BLDG (2S)
8,510.0	0.25	A-EXT1 (4S)
1,500.0	0.25	A-EXT2 (4S)
1,240.0	0.56	A-EXT3 (1S)
<b>30,900.0</b>	<b>0.56</b>	<b>TOTAL AREA</b>

**Summary for Subcatchment 1S: Controlled - Pipe + Cistern**

Runoff = 0.0899 m³/s @ 0.17 hrs, Volume= 598.4 m³, Depth= 56 mm

Runoff by Rational method, Rise/Fall=1.0/1.0 xTc, Time Span= 0.00-4.00 hrs, dt= 0.01 hrs  
 Ottawa 100-Year Duration=111 min, Inten=35.0 mm/hr

Area (m²)	C	Description
2,140.0	0.93	A-101
1,990.0	1.00	A-102
2,230.0	1.00	A-103
1,770.0	1.00	A-104
540.0	0.31	A-105
700.0	0.30	A-106
150.0	1.00	A-107
1,240.0	0.56	A-EXT3
10,760.0	0.86	Weighted Average
4,620.0		42.94% Pervious Area
6,140.0		57.06% Impervious Area

Tc (min)	Length (meters)	Slope (m/m)	Velocity (m/sec)	Capacity (m³/s)	Description
10.0					Direct Entry,

**Subcatchment 1S: Controlled - Pipe + Cistern**

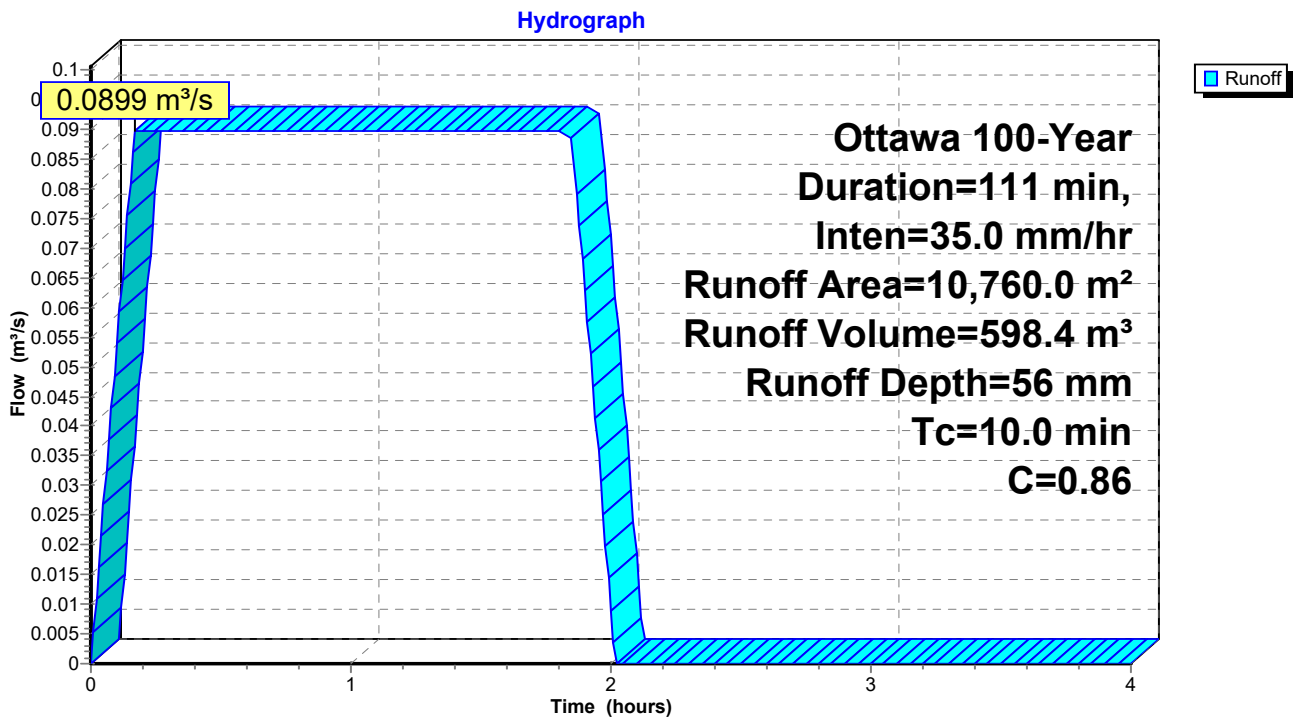

**Summary for Subcatchment 2S: Controlled - Rooftop Storage**

Runoff = 0.0376 m<sup>3</sup>/s @ 0.17 hrs, Volume= 250.3 m<sup>3</sup>, Depth= 65 mm

Runoff by Rational method, Rise/Fall=1.0/1.0 xTc, Time Span= 0.00-4.00 hrs, dt= 0.01 hrs  
 Ottawa 100-Year Duration=111 min, Inten=35.0 mm/hr

Area (m <sup>2</sup> )	C	Description
3,870.0	1.00	A-BLDG
3,870.0		100.00% Impervious Area

Tc (min)	Length (meters)	Slope (m/m)	Velocity (m/sec)	Capacity (m <sup>3</sup> /s)	Description
10.0					Direct Entry,

**Subcatchment 2S: Controlled - Rooftop Storage**

Hydrograph

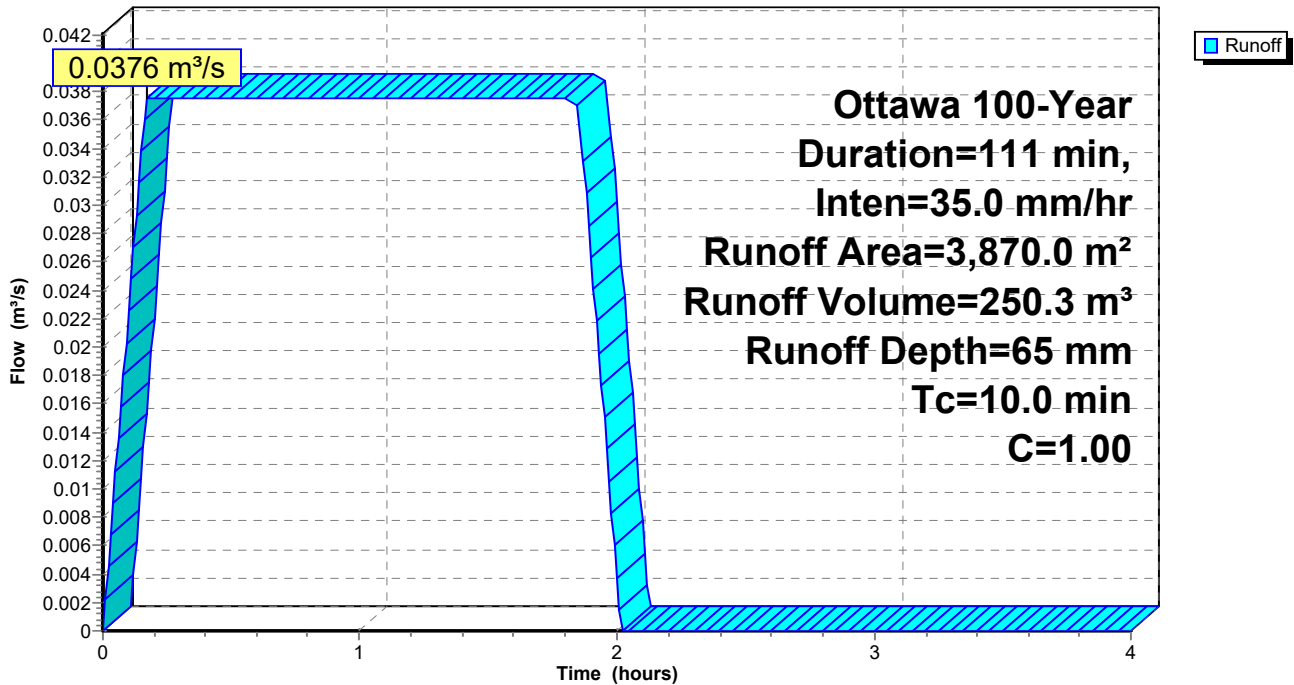

**Summary for Subcatchment 3S: Uncontrolled Site Areas**

Runoff = 0.0111 m<sup>3</sup>/s @ 0.29 hrs, Volume= 73.7 m<sup>3</sup>, Depth= 22 mm

Runoff by Rational method, Rise/Fall=1.0/1.0 xTc, Time Span= 0.00-4.00 hrs, dt= 0.01 hrs  
 Ottawa 100-Year Duration=111 min, Inten=35.0 mm/hr

Area (m <sup>2</sup> )	C	Description
200.0	0.38	A-111
110.0	0.41	A-112
110.0	0.41	A-113
2,440.0	0.33	A-108a
350.0	0.30	A-109a
140.0	0.44	A-110
3,350.0	0.34	Weighted Average
3,350.0		100.00% Pervious Area

Tc (min)	Length (meters)	Slope (m/m)	Velocity (m/sec)	Capacity (m <sup>3</sup> /s)	Description
17.2					Direct Entry,

**Subcatchment 3S: Uncontrolled Site Areas**

Hydrograph

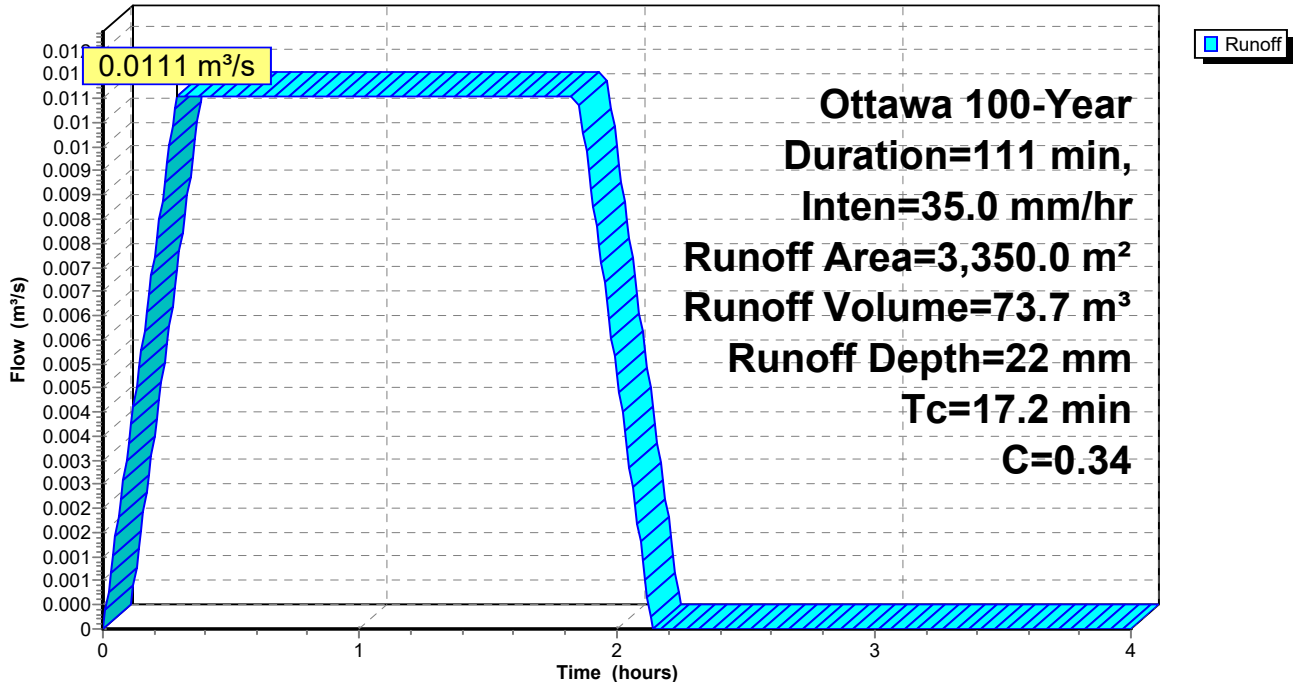

**Summary for Subcatchment 4S: Undeveloped (Bypass Controls)**

Runoff = 0.0314 m³/s @ 0.29 hrs, Volume= 208.9 m³, Depth= 16 mm

Runoff by Rational method, Rise/Fall=1.0/1.0 xTc, Time Span= 0.00-4.00 hrs, dt= 0.01 hrs  
 Ottawa 100-Year Duration=111 min, Inten=35.0 mm/hr

Area (m²)	C	Description
8,510.0	0.25	A-EXT1
1,500.0	0.25	A-EXT2
2,780.0	0.25	A-108b
130.0	0.25	A-109b
12,920.0	0.25	Weighted Average
12,920.0		100.00% Pervious Area

Tc (min)	Length (meters)	Slope (m/m)	Velocity (m/sec)	Capacity (m³/s)	Description
17.2					Direct Entry,

**Subcatchment 4S: Undeveloped (Bypass Controls)**

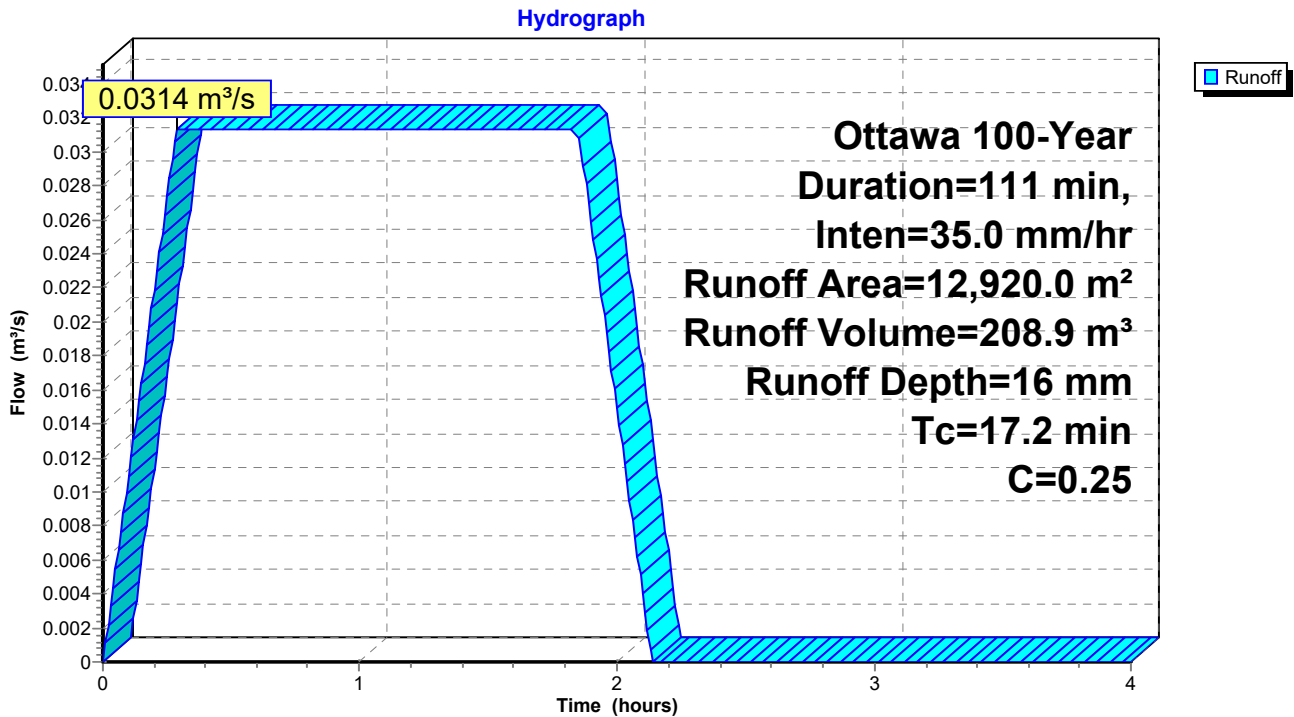

**Summary for Pond 1P: Cistern + Pipe Storage**

Inflow Area = 10,760.0 m<sup>2</sup>, 57.06% Impervious, Inflow Depth = 56 mm for 100-Year event  
 Inflow = 0.0899 m<sup>3</sup>/s @ 0.17 hrs, Volume= 598.4 m<sup>3</sup>  
 Outflow = 0.0288 m<sup>3</sup>/s @ 1.96 hrs, Volume= 324.6 m<sup>3</sup>, Atten= 68%, Lag= 107.6 min  
 Primary = 0.0288 m<sup>3</sup>/s @ 1.96 hrs, Volume= 324.6 m<sup>3</sup>  
 Secondary = 0.0000 m<sup>3</sup>/s @ 0.00 hrs, Volume= 0.0 m<sup>3</sup>

Routing by Stor-Ind method, Time Span= 0.00-4.00 hrs, dt= 0.01 hrs  
 Peak Elev= 104.075 m @ 1.96 hrs Surf.Area= 530.6 m<sup>2</sup> Storage= 458.9 m<sup>3</sup>

Plug-Flow detention time= 97.2 min calculated for 324.6 m<sup>3</sup> (54% of inflow)  
 Center-of-Mass det. time= 71.7 min ( 132.2 - 60.5 )

Volume	Invert	Avail.Storage	Storage Description
#1	103.218 m	461.6 m <sup>3</sup>	<b>10.00 mW x 53.06 mL x 0.87 mH Cistern</b>
#2	103.218 m	0.2 m <sup>3</sup>	<b>450 mm Round Pipe Storage</b> L= 1.55 m
#3	103.371 m	3.4 m <sup>3</sup>	<b>300 mm Round Pipe Storage</b> L= 47.40 m
#4	103.421 m	0.5 m <sup>3</sup>	<b>250 mm Round Pipe Storage</b> L= 10.45 m
		465.7 m <sup>3</sup>	Total Available Storage

Device	Routing	Invert	Outlet Devices
#1	Secondary	104.085 m	<b>***Overflow Check</b> Head (meters) 0.000 0.010 Disch. (m <sup>3</sup> /s) 0.00000 10.00000
#2	Primary	103.154 m	<b>122 mm Vert. Orifice/Grate</b> C= 0.600

**Primary OutFlow** Max=0.0288 m<sup>3</sup>/s @ 1.96 hrs HW=104.075 m (Free Discharge)  
 ↑**2=Orifice/Grate** (Orifice Controls 0.0288 m<sup>3</sup>/s @ 2.46 m/s)

**Secondary OutFlow** Max=0.0000 m<sup>3</sup>/s @ 0.00 hrs HW=103.218 m (Free Discharge)  
 ↑**1=\*\*\*Overflow Check** ( Controls 0.0000 m<sup>3</sup>/s)

### Pond 1P: Cistern + Pipe Storage

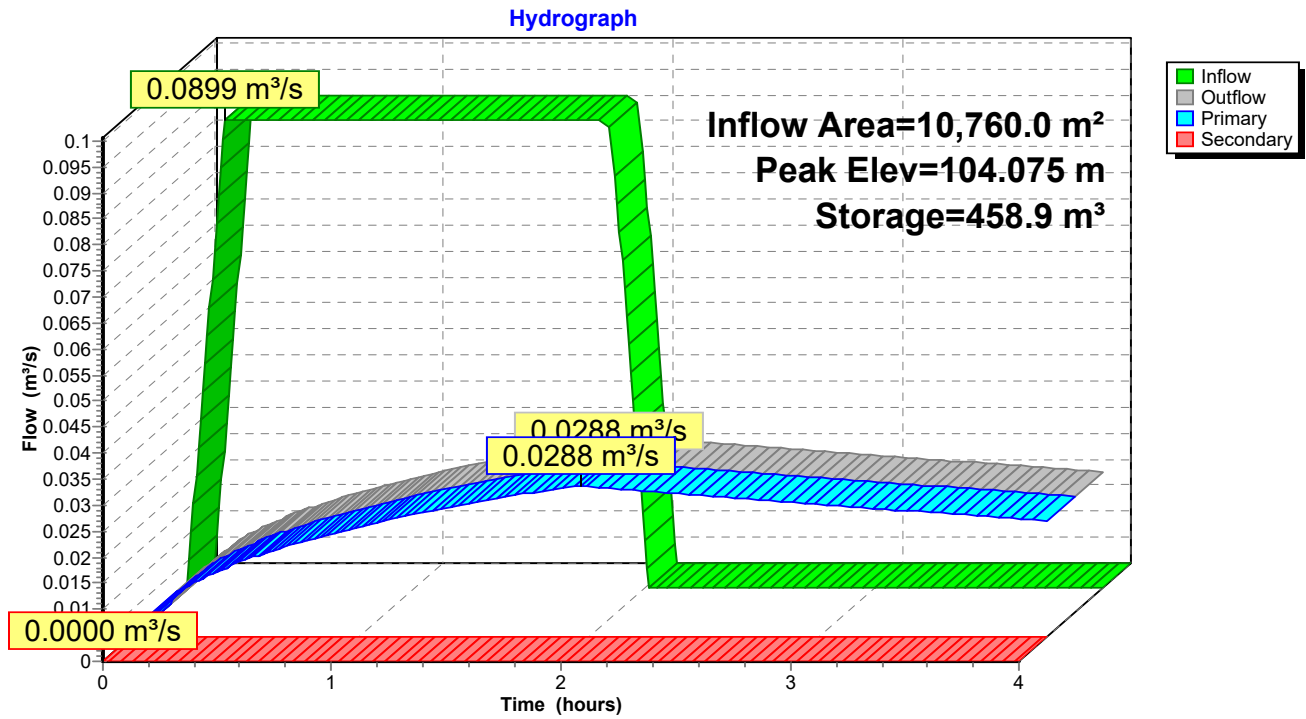



**Summary for Pond 2P: Rooftop Storage**

Inflow Area = 3,870.0 m<sup>2</sup>, 100.00% Impervious, Inflow Depth = 65 mm for 100-Year event  
 Inflow = 0.0376 m<sup>3</sup>/s @ 0.17 hrs, Volume= 250.3 m<sup>3</sup>  
 Outflow = 0.0110 m<sup>3</sup>/s @ 1.97 hrs, Volume= 133.2 m<sup>3</sup>, Atten= 71%, Lag= 107.9 min  
 Primary = 0.0110 m<sup>3</sup>/s @ 1.97 hrs, Volume= 133.2 m<sup>3</sup>

Routing by Stor-Ind method, Time Span= 0.00-4.00 hrs, dt= 0.01 hrs  
 Peak Elev= 100.152 m @ 1.97 hrs Surf.Area= 3,779.3 m<sup>2</sup> Storage= 191.1 m<sup>3</sup>

Plug-Flow detention time= 95.3 min calculated for 132.9 m<sup>3</sup> (53% of inflow)  
 Center-of-Mass det. time= 69.5 min ( 130.0 - 60.5 )

Volume	Invert	Avail.Storage	Storage Description	
#1	100.000 m	192.2 m <sup>3</sup>	<b>Custom Stage Data (Pyramidal)</b> Listed below (Recalc)	
Elevation (meters)	Surf.Area (sq-meters)	Inc.Store (cubic-meters)	Cum.Store (cubic-meters)	Wet.Area (sq-meters)
100.000	0.0	0.0	0.0	0.0
100.152	3,794.0	192.2	192.2	3,794.0

Device	Routing	Invert	Outlet Devices
#1	Primary	100.000 m	<b>Special &amp; User-Defined X 7.00</b> Head (meters) 0.000 0.152 Disch. (m <sup>3</sup> /s) 0.00000 0.00158

**Primary OutFlow** Max=0.0110 m<sup>3</sup>/s @ 1.97 hrs HW=100.152 m (Free Discharge)  
 ↑1=Special & User-Defined (Custom Controls 0.0110 m<sup>3</sup>/s)

### Pond 2P: Rooftop Storage

Hydrograph

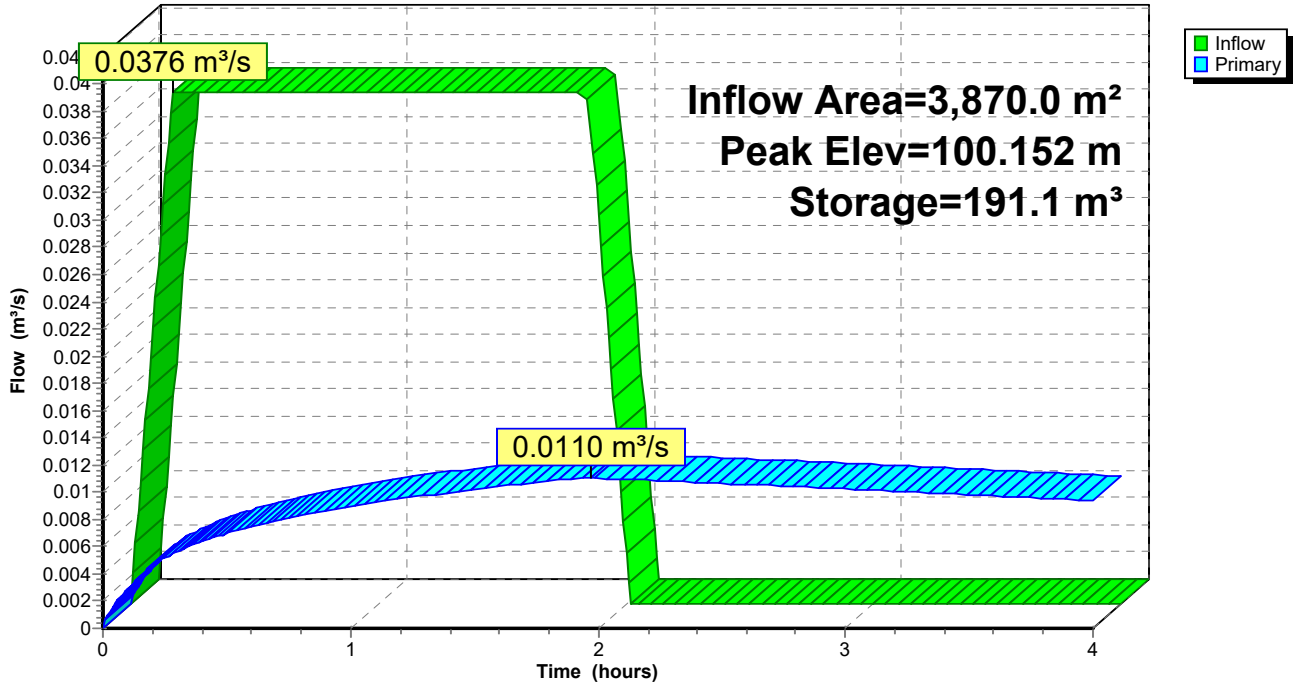

### Summary for Link 1L: Site Release

Inflow Area = 17,980.0 m<sup>2</sup>, 55.67% Impervious, Inflow Depth > 30 mm for 100-Year event  
Inflow = 0.0504 m<sup>3</sup>/s @ 1.85 hrs, Volume= 531.5 m<sup>3</sup>  
Primary = 0.0504 m<sup>3</sup>/s @ 1.85 hrs, Volume= 531.5 m<sup>3</sup>, Atten= 0%, Lag= 0.0 min

Primary outflow = Inflow, Time Span= 0.00-4.00 hrs, dt= 0.01 hrs

### Link 1L: Site Release

Hydrograph

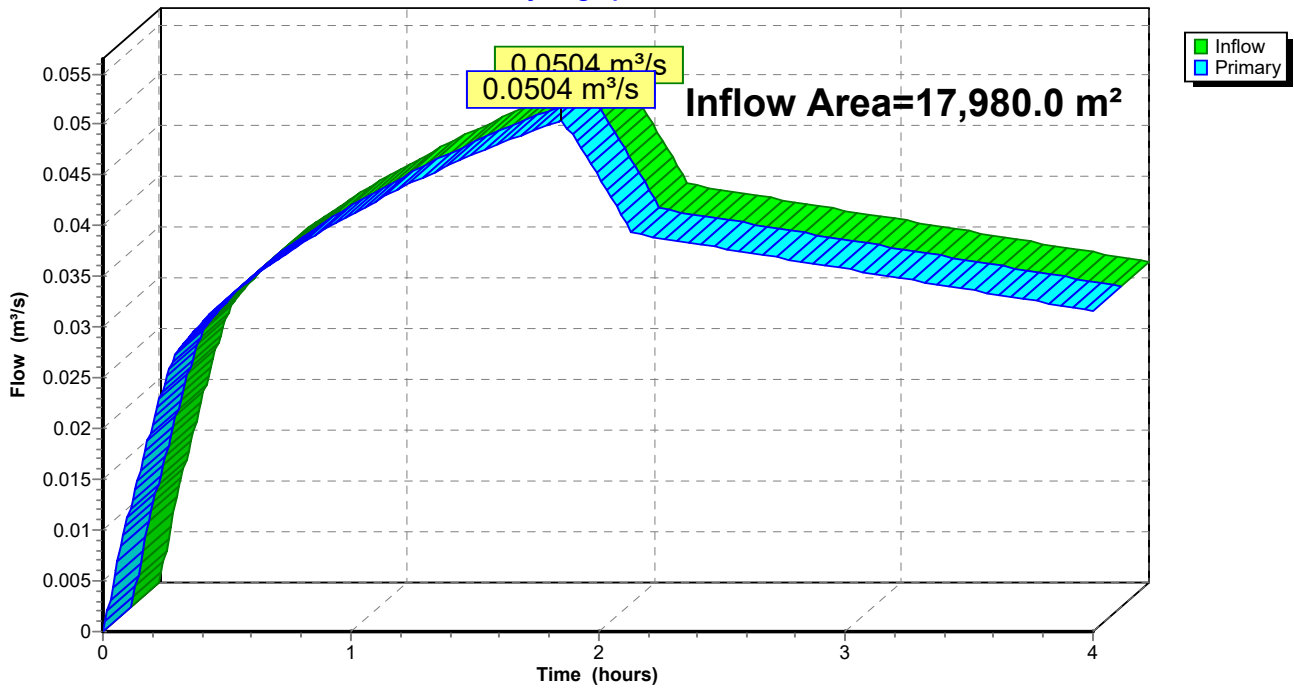

### Summary for Link 2L: Undeveloped Areas Directed Downstream of Controls

Inflow Area = 12,920.0 m<sup>2</sup>, 0.00% Impervious, Inflow Depth = 16 mm for 100-Year event  
Inflow = 0.0314 m<sup>3</sup>/s @ 0.29 hrs, Volume= 208.9 m<sup>3</sup>  
Primary = 0.0314 m<sup>3</sup>/s @ 0.29 hrs, Volume= 208.9 m<sup>3</sup>, Atten= 0%, Lag= 0.0 min

Primary outflow = Inflow, Time Span= 0.00-4.00 hrs, dt= 0.01 hrs

### Link 2L: Undeveloped Areas Directed Downstream of Controls

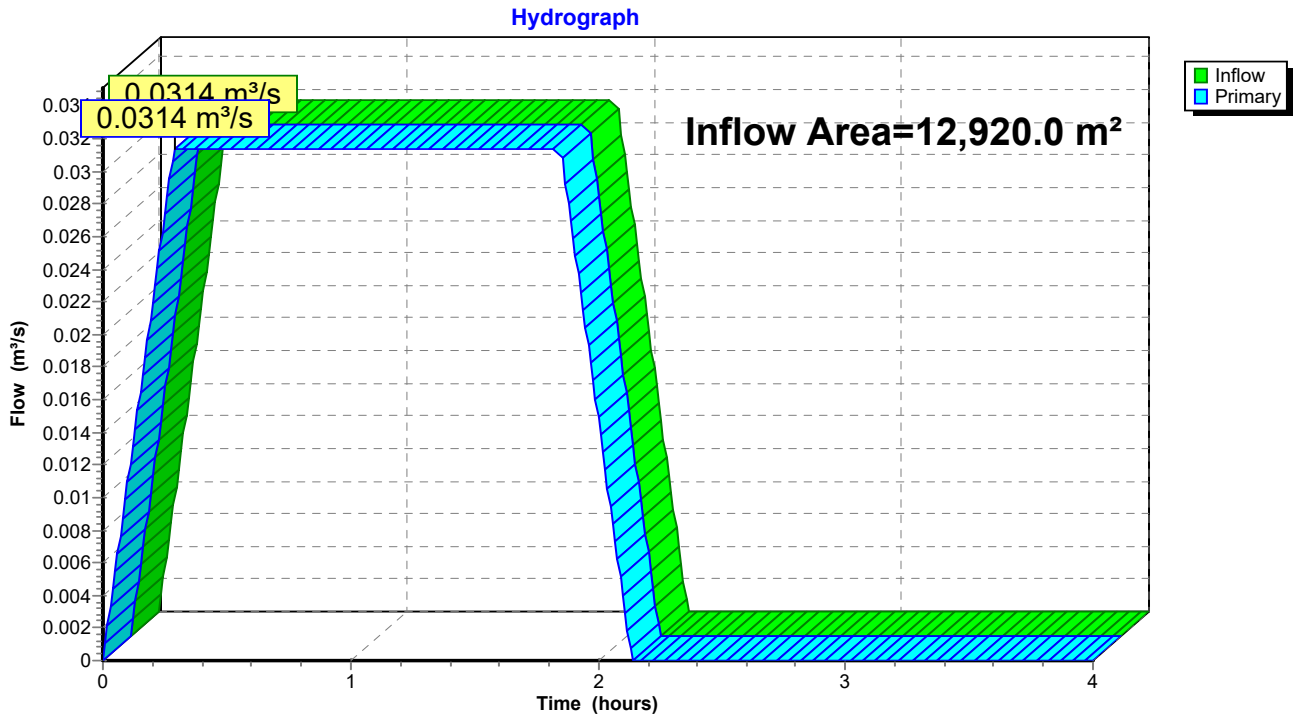

### Summary for Link 4L: Total Site Outflow

Inflow Area = 30,900.0 m<sup>2</sup>, 32.39% Impervious, Inflow Depth > 24 mm for 100-Year event  
Inflow = 0.0819 m<sup>3</sup>/s @ 1.85 hrs, Volume= 740.4 m<sup>3</sup>  
Primary = 0.0819 m<sup>3</sup>/s @ 1.85 hrs, Volume= 740.4 m<sup>3</sup>, Atten= 0%, Lag= 0.0 min

Primary outflow = Inflow, Time Span= 0.00-4.00 hrs, dt= 0.01 hrs

### Link 4L: Total Site Outflow

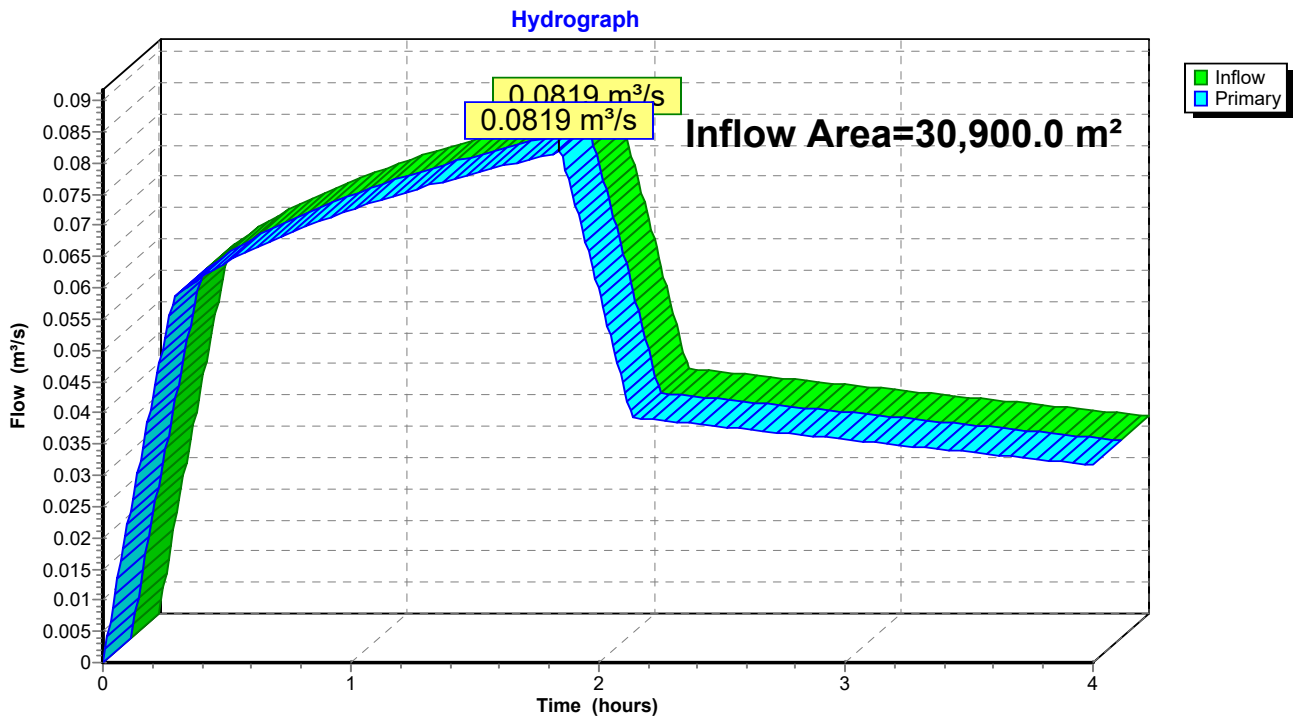

# APPENDIX

# H

Parcel 2 - Model Output  
(PCSWMM)



-  Outlets
  -  Weirs
  -  Orifices
  -  Conduits
  -  Storages
  -  Outfalls
  -  Junctions
- Subcatchments
-  Other
  -  Uncontrolled
  -  Cistern
  -  Other
  -  Rooftop
  -  Undeveloped

10-year 24-hour Chicago Distribution Report File Provided. Other distributions are available upon request.

EPA STORM WATER MANAGEMENT MODEL - VERSION 5.1 (Build 5.1.015)

\*\*\*\*\*  
 Element Count  
 \*\*\*\*\*

Number of rain gages ..... 60  
 Number of subcatchments ... 16  
 Number of nodes ..... 17  
 Number of links ..... 15  
 Number of pollutants ..... 0  
 Number of land uses ..... 0

\*\*\*\*\*  
 Raingage Summary  
 \*\*\*\*\*

Name	Data Source	Data Type	Recording Interval
100yr_3hr_Chicago	C:\Users\michael.stewart\OneDrive - WSP		
0365\Projects\Campeau Drive\PCSWMM\2021-05-13\Rainfall\100yr_3hr_Chicago.dat			
100yr_3hr_Chicago_Climate_Change	100yr_3hr_Chicago_Increase_20percent	INTENSITY	10 min.
100yr_6hr_Chicago	C:\Users\michael.stewart\OneDrive - WSP		
0365\Projects\Campeau Drive\PCSWMM\2021-05-13\Rainfall\100yr_6hr_Chicago.dat			
100yr_6hr_Chicago_Climate_Change	100yr_6hr_Chicago_Increase_20percent	INTENSITY	10 min.
100yrAES12hr	100yrAES12hr	INTENSITY	5 min.
100yrChicago	100yrChicago	INTENSITY	10 min.
100yrChicago12hr	C:\Users\michael.stewart\OneDrive - WSP		
0365\Projects\Campeau Drive\PCSWMM\2021-05-13\Rainfall\100yrChicago12hr.dat			
100yrChicago24hr	C:\Users\michael.stewart\OneDrive - WSP		
0365\Projects\Campeau Drive\PCSWMM\2021-05-13\Rainfall\100yrChicago24hr.dat			
100yrChicago3hr	100yrChicago	INTENSITY	10 min.
100yrChicago6hr	100yrChicago6hr	INTENSITY	10 min.
100yrSCS24hr	100yrSCS24hr	INTENSITY	10 min.
10yr_24hr_Chi	10yr_24hr_Chi	INTENSITY	10 min.
10yr_3hr_Chicago	C:\Users\michael.stewart\OneDrive - WSP		
0365\Projects\Campeau Drive\PCSWMM\2021-05-13\Rainfall\10yr_3hr_Chicago.dat			
10yr_6hr_Chicago	C:\Users\michael.stewart\OneDrive - WSP		
0365\Projects\Campeau Drive\PCSWMM\2021-05-13\Rainfall\10yr_6hr_Chicago.dat			
10yrChicago	10yrChicago	INTENSITY	10 min.
10yrChicago24hr	C:\Users\michael.stewart\OneDrive - WSP		
0365\Projects\Campeau Drive\PCSWMM\2021-05-13\Rainfall\10yrChicago24hr.dat			
10yrChicago3hr	10yrChicago	INTENSITY	10 min.
10yrSCS24hr	10yrSCS24hr	INTENSITY	10 min.
25mm_3hr_Chicago	25mm_3hr_Chicago	INTENSITY	10 min.

25mm_4hr_Chicago	25mm_4hr_Chicago	INTENSITY	10 min.
25yr_3hr_Chicago	25yr_3hr_Chicago	INTENSITY	10 min.
25yr_6hr_Chicago	25yr_6hr_Chicago	INTENSITY	10 min.
25yrAES12hr	25yrAES12hr	INTENSITY	5 min.
25yrChicago	25yrChicago	INTENSITY	10 min.
25yrChicago12hr	25yrChicago12hr	INTENSITY	10 min.
25yrChicago24hr	25yrChicago24hr	INTENSITY	10 min.
25yrChicago3hr	25yrChicago	INTENSITY	10 min.
25yrChicago6hr	25yrChicago6hr	INTENSITY	10 min.
25yrSCS24hr	25yrSCS24hr	INTENSITY	10 min.
2yr_3hr_Chicago	2yr_3hr_Chicago	INTENSITY	10 min.
2yr_6hr_Chicago	2yr_6hr_Chicago	INTENSITY	10 min.
2yrChicago	2yrChicago	INTENSITY	10 min.
2yrChicago24hr	2yrChicago24hr	INTENSITY	10 min.
2yrChicago3hr	2yrChicago	INTENSITY	10 min.
2yrSCS24hr	2yrSCS24hr	INTENSITY	10 min.
50yr_3hr_Chicago	50yr_3hr_Chicago	INTENSITY	10 min.
50yr_6hr_Chicago	50yr_6hr_Chicago	INTENSITY	10 min.
50yrChicago	50yrChicago	INTENSITY	10 min.
50yrChicago24hr	50yrChicago24hr	INTENSITY	10 min.
50yrChicago3hr	50yrChicago	INTENSITY	10 min.
50yrSCS24hr	50yrSCS24hr	INTENSITY	10 min.
5yr_3hr_Chicago	5yr_3hr_Chicago	INTENSITY	10 min.
5yr_6hr_Chicago	5yr_6hr_Chicago	INTENSITY	10 min.
5yrAES12hr	5yrAES12hr	INTENSITY	5 min.
5yrChicago	C:\Users\michael.stewart\OneDrive - WSP		
0365\Projects\Campeau Drive\PCSWMM\2021-05-13\Rainfall\5yrChicago3hr.dat			
5yrChicago12hr	C:\Users\michael.stewart\OneDrive - WSP		
0365\Projects\Campeau Drive\PCSWMM\2021-05-13\Rainfall\5yrChicago12hr.dat			
5yrChicago24hr	C:\Users\michael.stewart\OneDrive - WSP		
0365\Projects\Campeau Drive\PCSWMM\2021-05-13\Rainfall\5yrChicago24hr.dat			
5yrChicago3hr	C:\Users\michael.stewart\OneDrive - WSP		
0365\Projects\Campeau Drive\PCSWMM\2021-05-13\Rainfall\5yrChicago3hr.dat			
5yrChicago6hr	C:\Users\michael.stewart\OneDrive - WSP		
0365\Projects\Campeau Drive\PCSWMM\2021-05-13\Rainfall\5yrChicago6hr.dat			
5yrSCS24	5yrSCS24hr	INTENSITY	10 min.
BLANK	BLANK	INTENSITY	10 min.
Continuous	2010Precipitation	VOLUME	15 min.
MT0_100yrSCS12hr	MT0_100yrSCS12hr	INTENSITY	15 min.
MT0_10yrSCS12hr	MT0_10yrSCS12hr	INTENSITY	15 min.
MT0_20mmSCS12hr	MT0_20mmSCS12hr	INTENSITY	15 min.
MT0_25mmSCS12hr	MT0_25mmSCS12hr	INTENSITY	15 min.
MT0_25yrSCS12hr	MT0_25yrSCS12hr	INTENSITY	15 min.
MT0_2yrSCS12hr	MT0_2yrSCS12hr	INTENSITY	15 min.
MT0_50yrSCS12hr	MT0_50yrSCS12hr	INTENSITY	15 min.
Rainfall1980	Rainfall1980	INTENSITY	5 min.

\*\*\*\*\*  
 Subcatchment Summary



\*\*\*\*\*

Name Outlet	Area	Width	%Imperv	%Slope	Rain Gage
B-101	0.15	8.18	24.00	0.5000	10yr_24hr_Chi
CanadianShieldAve_DICB					
B-102	0.04	18.95	71.00	0.5000	10yr_24hr_Chi
CBMH209					
B-103	0.15	36.60	41.00	0.5000	10yr_24hr_Chi
B01					
B-104	0.06	21.30	95.00	0.5000	10yr_24hr_Chi
CBMH211					
B-105	0.12	40.40	93.00	0.5000	10yr_24hr_Chi
CBMH210					
B-106	0.12	30.80	96.00	0.5000	10yr_24hr_Chi
CBMH207					
B-107	0.16	45.20	75.00	0.5000	10yr_24hr_Chi
Cistern					
B-108	0.07	35.90	97.00	0.5000	10yr_24hr_Chi
STMH205					
B-109	0.01	3.80	25.00	0.5000	10yr_24hr_Chi
RYCB213					
B-110	0.02	4.83	11.00	0.5000	10yr_24hr_Chi
STMH205					
B-111	0.05	16.17	61.00	0.5000	10yr_24hr_Chi
Cistern					
B-112	0.02	4.75	26.00	0.5000	10yr_24hr_Chi
Cordillera_Major					
B-113	0.01	1.71	100.00	0.5000	10yr_24hr_Chi
RYCB213					
B-114	0.01	1.60	100.00	0.5000	10yr_24hr_Chi
RYCB213					
B-BLDG	0.28	22.97	100.00	0.5000	10yr_24hr_Chi
BLDG					
B-EXT1	0.44	36.42	0.00	0.5000	10yr_24hr_Chi
CanadianShieldAve_DICB					

\*\*\*\*\*  
Node Summary  
\*\*\*\*\*

Name	Type	Invert Elev.	Max. Depth	Ponded Area	External Inflow
B01	JUNCTION	100.18	4.62	0.0	
CB202	JUNCTION	101.67	1.64	0.0	
CBMH206	JUNCTION	99.50	3.61	0.0	
CBMH207	JUNCTION	99.58	3.87	0.0	

CBMH209	JUNCTION	100.00	3.99	0.0
CBMH210	JUNCTION	99.94	4.03	0.0
CBMH211	JUNCTION	100.07	4.73	0.0
CisternDS	JUNCTION	99.31	2.75	0.0
RYCB213	JUNCTION	101.85	2.20	0.0
STMH202	JUNCTION	99.23	2.51	0.0
STMH205	JUNCTION	99.41	3.90	0.0
STMH208	JUNCTION	99.70	4.34	0.0
CanadianShieldAve_DICB	OUTFALL	0.00	0.00	0.0
Cordillera_Major	OUTFALL	0.00	0.00	0.0
Cordillera_Minor	OUTFALL	98.95	0.30	0.0
BLDG	STORAGE	110.00	0.35	0.0
Cistern	STORAGE	99.31	3.08	0.0

\*\*\*\*\*  
Link Summary  
\*\*\*\*\*

Name	From Node	To Node	Type	Length
C1	STMH205	Cistern	CONDUIT	33.8
C10	B01	CBMH211	CONDUIT	16.0
C11	CisternDS	STMH202	CONDUIT	5.2
C13	STMH202	Cordillera_Minor	CONDUIT	14.3
C14	CB202	STMH205	CONDUIT	8.3
C15	RYCB213	CB202	CONDUIT	16.5
C3	CBMH206	STMH205	CONDUIT	10.4
C4	CBMH207	CBMH206	CONDUIT	24.1
C5	STMH208	CBMH207	CONDUIT	13.9
C6	CBMH209	STMH208	CONDUIT	22.8
C8	CBMH210	STMH208	CONDUIT	17.8
C9	CBMH211	CBMH210	CONDUIT	17.0
OR1	Cistern	CisternDS	ORIFICE	
W1	Cistern	Cordillera_Major	WEIR	
OL1	BLDG	STMH202	OUTLET	

\*\*\*\*\*  
 Cross Section Summary  
 \*\*\*\*\*

Full Conduit Flow	Shape	Full Depth	Full Area	Hyd. Rad.	Max. Width	No. of Barrels
C1	CIRCULAR	0.45	0.16	0.11	0.45	1
0.16						
C10	CIRCULAR	0.25	0.05	0.06	0.25	1
0.04						
C11	CIRCULAR	0.36	0.10	0.09	0.36	1
0.08						
C13	CIRCULAR	0.30	0.07	0.07	0.30	1
0.14						
C14	CIRCULAR	0.20	0.03	0.05	0.20	1
0.03						
C15	CIRCULAR	0.20	0.03	0.05	0.20	1
0.04						
C3	CIRCULAR	0.45	0.16	0.11	0.45	1
0.14						
C4	CIRCULAR	0.45	0.16	0.11	0.45	1
0.14						
C5	CIRCULAR	0.38	0.11	0.09	0.38	1
0.10						
C6	CIRCULAR	0.25	0.05	0.06	0.25	1
0.05						
C8	CIRCULAR	0.30	0.07	0.07	0.30	1
0.07						
C9	CIRCULAR	0.25	0.05	0.06	0.25	1
0.04						

\*\*\*\*\*  
 Transect Summary  
 \*\*\*\*\*

Transect Overland\_Outlet2  
 Area:

0.0015	0.0036	0.0065	0.0100	0.0142
0.0190	0.0246	0.0308	0.0377	0.0453
0.0535	0.0625	0.0721	0.0824	0.0934
0.1051	0.1174	0.1304	0.1441	0.1585
0.1735	0.1893	0.2057	0.2228	0.2406

0.2590	0.2782	0.2980	0.3185	0.3396
0.3615	0.3840	0.4072	0.4312	0.4566
0.4833	0.5114	0.5408	0.5716	0.6038
0.6373	0.6722	0.7084	0.7460	0.7849
0.8252	0.8669	0.9099	0.9543	1.0000

Hrad:	0.0377	0.0675	0.0945	0.1201	0.1450
0.1694	0.1936	0.2175	0.2413	0.2650	
0.2886	0.3122	0.3357	0.3591	0.3826	
0.4060	0.4293	0.4527	0.4760	0.4994	
0.5227	0.5460	0.5693	0.5925	0.6158	
0.6391	0.6623	0.6856	0.7088	0.7321	
0.7553	0.7786	0.8018	0.8102	0.8132	
0.8182	0.8249	0.8331	0.8426	0.8532	
0.8648	0.8773	0.8906	0.9046	0.9193	
0.9345	0.9502	0.9664	0.9830	1.0000	

Width:	0.0390	0.0537	0.0683	0.0829	0.0976
0.1122	0.1268	0.1415	0.1561	0.1707	
0.1854	0.2000	0.2146	0.2293	0.2439	
0.2585	0.2732	0.2878	0.3024	0.3171	
0.3317	0.3463	0.3610	0.3756	0.3902	
0.4049	0.4195	0.4341	0.4488	0.4634	
0.4780	0.4927	0.5073	0.5317	0.5610	
0.5902	0.6195	0.6488	0.6780	0.7073	
0.7366	0.7659	0.7951	0.8244	0.8537	
0.8829	0.9122	0.9415	0.9707	1.0000	

Transect RYCB_Overland Area:	0.0009	0.0026	0.0050	0.0081	0.0121
0.0168	0.0222	0.0284	0.0354	0.0431	
0.0516	0.0609	0.0709	0.0816	0.0931	
0.1054	0.1183	0.1320	0.1464	0.1616	
0.1775	0.1941	0.2114	0.2294	0.2482	
0.2678	0.2880	0.3090	0.3307	0.3531	
0.3763	0.4002	0.4248	0.4501	0.4762	
0.5030	0.5306	0.5595	0.5895	0.6207	
0.6532	0.6869	0.7218	0.7579	0.7952	
0.8337	0.8735	0.9144	0.9566	1.0000	

Hrad:	0.0309	0.0552	0.0782	0.1008	0.1232
0.1454	0.1676	0.1898	0.2119	0.2340	
0.2561	0.2781	0.3002	0.3225	0.3453	
0.3681	0.3907	0.4133	0.4358	0.4583	
0.4807	0.5031	0.5254	0.5477	0.5700	
0.5923	0.6146	0.6368	0.6590	0.6812	
0.7034	0.7256	0.7478	0.7699	0.7921	
0.8142	0.8274	0.8363	0.8463	0.8572	
0.8690	0.8814	0.8945	0.9082	0.9224	

Width:	0.9371	0.9523	0.9678	0.9837	1.0000	0.0012	0.0034	0.0061	0.0092	0.0128
	0.0290	0.0463	0.0635	0.0808	0.0980	0.0167	0.0209	0.0256	0.0307	0.0364
	0.1153	0.1325	0.1498	0.1671	0.1843	0.0425	0.0492	0.0565	0.0643	0.0727
	0.2016	0.2188	0.2361	0.2531	0.2696	0.0818	0.0913	0.1014	0.1121	0.1244
	0.2862	0.3028	0.3193	0.3359	0.3525	0.1421	0.1616	0.1813	0.2012	0.2212
	0.3690	0.3856	0.4022	0.4187	0.4353	0.2415	0.2621	0.2835	0.3062	0.3303
	0.4519	0.4684	0.4850	0.5016	0.5181	0.3559	0.3848	0.4166	0.4506	0.4846
	0.5347	0.5512	0.5678	0.5844	0.6009	0.5187	0.5528	0.5870	0.6213	0.6556
	0.6175	0.6411	0.6687	0.6963	0.7239	0.6899	0.7242	0.7586	0.7930	0.8274
	0.7515	0.7791	0.8067	0.8344	0.8620	0.8619	0.8964	0.9309	0.9654	1.0000
	0.8896	0.9172	0.9448	0.9724	1.0000					
						Hrad:				

Transect T_Major_Asphalt_Overflow_10m										
Area:										
0.0200	0.0400	0.0600	0.0800	0.1000	0.2433	0.2579	0.2705	0.2772	0.2712	0.2712
0.1200	0.1400	0.1600	0.1800	0.2000	0.2850	0.3038	0.3282	0.3552	0.3840	0.3840
0.2200	0.2400	0.2600	0.2800	0.3000	0.4109	0.4355	0.4497	0.4496	0.4662	0.4662
0.3200	0.3400	0.3600	0.3800	0.4000	0.4558	0.4485	0.4582	0.4747	0.5073	0.5073
0.4200	0.4400	0.4600	0.4800	0.5000	0.5397	0.5718	0.6036	0.6367	0.6703	0.6703
0.5200	0.5400	0.5600	0.5800	0.6000	0.7038	0.7372	0.7705	0.8036	0.8367	0.8367
0.6200	0.6400	0.6600	0.6800	0.7000	0.8696	0.9024	0.9350	0.9676	1.0000	1.0000
0.7200	0.7400	0.7600	0.7800	0.8000						
0.8200	0.8400	0.8600	0.8800	0.9000	Width:					
0.9200	0.9400	0.9600	0.9800	1.0000	0.0535	0.0717	0.0839	0.0973	0.1084	0.1084
					0.1183	0.1287	0.1416	0.1553	0.1692	0.1692
Hrad:					0.1862	0.2020	0.2171	0.2350	0.2532	0.2532
0.0316	0.0625	0.0927	0.1221	0.1509	0.2689	0.2830	0.2995	0.3237	0.4231	0.4231
0.1791	0.2066	0.2336	0.2599	0.2857	0.5561	0.5670	0.5721	0.5772	0.5823	0.5823
0.3110	0.3357	0.3599	0.3836	0.4068	0.5913	0.6042	0.6315	0.6819	0.7118	0.7118
0.4295	0.4518	0.4737	0.4951	0.5161	0.7906	0.8795	0.9809	0.9828	0.9845	0.9845
0.5367	0.5570	0.5768	0.5963	0.6154	0.9862	0.9879	0.9896	0.9907	0.9915	0.9915
0.6341	0.6526	0.6707	0.6884	0.7059	0.9924	0.9932	0.9941	0.9949	0.9958	0.9958
0.7230	0.7399	0.7564	0.7727	0.7887	0.9966	0.9975	0.9983	0.9992	1.0000	1.0000
0.8045	0.8199	0.8352	0.8501	0.8649						
0.8794	0.8936	0.9077	0.9215	0.9351						
0.9485	0.9616	0.9746	0.9874	1.0000						
					Transect T_Major_Grass_Overflow_15m					
Area:										
0.0200	0.0400	0.0600	0.0800	0.1000	0.0200	0.0400	0.0600	0.0800	0.1000	0.1000
0.1200	0.1400	0.1600	0.1800	0.2000	0.1200	0.1400	0.1600	0.1800	0.2000	0.2000
0.2200	0.2400	0.2600	0.2800	0.3000	0.2200	0.2400	0.2600	0.2800	0.3000	0.3000
0.3200	0.3400	0.3600	0.3800	0.4000	0.3200	0.3400	0.3600	0.3800	0.4000	0.4000
0.4200	0.4400	0.4600	0.4800	0.5000	0.4200	0.4400	0.4600	0.4800	0.5000	0.5000
0.5200	0.5400	0.5600	0.5800	0.6000	0.5200	0.5400	0.5600	0.5800	0.6000	0.6000
0.6200	0.6400	0.6600	0.6800	0.7000	0.6200	0.6400	0.6600	0.6800	0.7000	0.7000
0.7200	0.7400	0.7600	0.7800	0.8000	0.7200	0.7400	0.7600	0.7800	0.8000	0.8000
0.8200	0.8400	0.8600	0.8800	0.9000	0.8200	0.8400	0.8600	0.8800	0.9000	0.9000
0.9200	0.9400	0.9600	0.9800	1.0000	0.9200	0.9400	0.9600	0.9800	1.0000	1.0000
Hrad:					0.0278	0.0551	0.0820	0.1085	0.1346	0.1346
0.0316	0.0625	0.0927	0.1221	0.1509	0.1603	0.1856	0.2105	0.2351	0.2593	0.2593
0.1791	0.2066	0.2336	0.2599	0.2857	0.2831	0.3066	0.3297	0.3525	0.3750	0.3750
0.3110	0.3357	0.3599	0.3836	0.4068	0.3972	0.4190	0.4406	0.4618	0.4828	0.4828
0.4295	0.4518	0.4737	0.4951	0.5161						
0.5367	0.5570	0.5768	0.5963	0.6154						
0.6341	0.6526	0.6707	0.6884	0.7059						
0.7230	0.7399	0.7564	0.7727	0.7887						
0.8045	0.8199	0.8352	0.8501	0.8649						
0.8794	0.8936	0.9077	0.9215	0.9351						
0.9485	0.9616	0.9746	0.9874	1.0000						

Transect T_Major_Graham_Creek_01										
Area:										
0.0200	0.0400	0.0600	0.0800	0.1000	0.0200	0.0400	0.0600	0.0800	0.1000	0.1000
0.1200	0.1400	0.1600	0.1800	0.2000	0.1200	0.1400	0.1600	0.1800	0.2000	0.2000
0.2200	0.2400	0.2600	0.2800	0.3000	0.2200	0.2400	0.2600	0.2800	0.3000	0.3000
0.3200	0.3400	0.3600	0.3800	0.4000	0.3200	0.3400	0.3600	0.3800	0.4000	0.4000
0.4200	0.4400	0.4600	0.4800	0.5000	0.4200	0.4400	0.4600	0.4800	0.5000	0.5000
0.5200	0.5400	0.5600	0.5800	0.6000	0.5200	0.5400	0.5600	0.5800	0.6000	0.6000
0.6200	0.6400	0.6600	0.6800	0.7000	0.6200	0.6400	0.6600	0.6800	0.7000	0.7000
0.7200	0.7400	0.7600	0.7800	0.8000	0.7200	0.7400	0.7600	0.7800	0.8000	0.8000
0.8200	0.8400	0.8600	0.8800	0.9000	0.8200	0.8400	0.8600	0.8800	0.9000	0.9000
0.9200	0.9400	0.9600	0.9800	1.0000	0.9200	0.9400	0.9600	0.9800	1.0000	1.0000
Hrad:					0.0278	0.0551	0.0820	0.1085	0.1346	0.1346
0.0316	0.0625	0.0927	0.1221	0.1509	0.1603	0.1856	0.2105	0.2351	0.2593	0.2593
0.1791	0.2066	0.2336	0.2599	0.2857	0.2831	0.3066	0.3297	0.3525	0.3750	0.3750
0.3110	0.3357	0.3599	0.3836	0.4068	0.3972	0.4190	0.4406	0.4618	0.4828	0.4828
0.4295	0.4518	0.4737	0.4951	0.5161						
0.5367	0.5570	0.5768	0.5963	0.6154						
0.6341	0.6526	0.6707	0.6884	0.7059						
0.7230	0.7399	0.7564	0.7727	0.7887						
0.8045	0.8199	0.8352	0.8501	0.8649						
0.8794	0.8936	0.9077	0.9215	0.9351						
0.9485	0.9616	0.9746	0.9874	1.0000						





	0.4618	0.4843	0.5067	0.5291	0.5515		0.9215	0.9413	0.9609	0.9805	1.0000
	0.5740	0.5964	0.6188	0.6412	0.6636	Width:	0.1200	0.2400	0.3550	0.4150	0.4750
	0.6861	0.7085	0.7309	0.7533	0.7758		0.5850	0.6450	0.7050	0.7650	0.8250
	0.7982	0.8206	0.8430	0.8655	0.8879		0.8850	0.9450	1.0000	1.0000	1.0000
Hrad:	0.9103	0.9327	0.9552	0.9776	1.0000		1.0000	1.0000	1.0000	1.0000	1.0000
	0.0182	0.0364	0.0539	0.0825	0.1092		1.0000	1.0000	1.0000	1.0000	1.0000
	0.1328	0.1540	0.1733	0.1910	0.2075		1.0000	1.0000	1.0000	1.0000	1.0000
	0.2229	0.2375	0.2517	0.2705	0.2900		1.0000	1.0000	1.0000	1.0000	1.0000
	0.3100	0.3303	0.3508	0.3715	0.3923		1.0000	1.0000	1.0000	1.0000	1.0000
	0.4131	0.4340	0.4548	0.4757	0.4965		1.0000	1.0000	1.0000	1.0000	1.0000
	0.5173	0.5381	0.5588	0.5795	0.6001		1.0000	1.0000	1.0000	1.0000	1.0000
	0.6207	0.6412	0.6617	0.6821	0.7025		1.0000	1.0000	1.0000	1.0000	1.0000
	0.7227	0.7430	0.7631	0.7832	0.8032	Transect T_Major_Roads_20M_CURB_MEDIAN					
	0.8232	0.8431	0.8629	0.8827	0.9024	Area:	0.0033	0.0117	0.0217	0.0337	0.0467
Width:	0.9221	0.9416	0.9612	0.9806	1.0000		0.0608	0.0758	0.0918	0.1089	0.1270
	0.1200	0.2400	0.3900	0.4650	0.5250		0.1461	0.1662	0.1873	0.2092	0.2312
	0.5850	0.6450	0.7050	0.7650	0.8250		0.2532	0.2751	0.2971	0.3191	0.3410
	0.8850	0.9450	1.0000	1.0000	1.0000		0.3630	0.3850	0.4069	0.4289	0.4509
	1.0000	1.0000	1.0000	1.0000	1.0000		0.4728	0.4948	0.5167	0.5387	0.5607
	1.0000	1.0000	1.0000	1.0000	1.0000		0.5826	0.6046	0.6266	0.6485	0.6705
	1.0000	1.0000	1.0000	1.0000	1.0000		0.6925	0.7144	0.7364	0.7584	0.7803
	1.0000	1.0000	1.0000	1.0000	1.0000		0.8023	0.8243	0.8462	0.8682	0.8902
	1.0000	1.0000	1.0000	1.0000	1.0000	Hrad:	0.9121	0.9341	0.9561	0.9780	1.0000
	1.0000	1.0000	1.0000	1.0000	1.0000		0.0160	0.0422	0.0618	0.0903	0.1163
Transect T_Major_Roads_15M_CURB_MEDIAN							0.1403	0.1626	0.1834	0.2029	0.2213
Area:	0.0013	0.0054	0.0122	0.0208	0.0309		0.2387	0.2553	0.2710	0.2884	0.3074
	0.0431	0.0569	0.0721	0.0886	0.1065		0.3268	0.3464	0.3663	0.3863	0.4065
	0.1257	0.1463	0.1682	0.1907	0.2132		0.4266	0.4469	0.4671	0.4874	0.5076
	0.2356	0.2581	0.2806	0.3031	0.3256		0.5278	0.5480	0.5682	0.5883	0.6084
	0.3480	0.3705	0.3930	0.4155	0.4380		0.6285	0.6485	0.6684	0.6883	0.7082
	0.4605	0.4829	0.5054	0.5279	0.5504		0.7280	0.7478	0.7675	0.7871	0.8068
	0.5729	0.5953	0.6178	0.6403	0.6628		0.8263	0.8458	0.8653	0.8847	0.9040
	0.6853	0.7077	0.7302	0.7527	0.7752	Width:	0.9233	0.9426	0.9618	0.9809	1.0000
	0.7977	0.8202	0.8426	0.8651	0.8876		0.3000	0.4000	0.5231	0.5692	0.6154
Hrad:	0.9101	0.9326	0.9550	0.9775	1.0000		0.6615	0.7077	0.7538	0.8000	0.8462
	0.0185	0.0371	0.0599	0.0892	0.1136		0.8923	0.9385	0.9846	1.0000	1.0000
	0.1225	0.1442	0.1639	0.1821	0.1991		1.0000	1.0000	1.0000	1.0000	1.0000
	0.2149	0.2299	0.2446	0.2638	0.2837		1.0000	1.0000	1.0000	1.0000	1.0000
	0.3040	0.3246	0.3455	0.3664	0.3874		1.0000	1.0000	1.0000	1.0000	1.0000
	0.4085	0.4296	0.4506	0.4717	0.4927		1.0000	1.0000	1.0000	1.0000	1.0000
	0.5137	0.5347	0.5556	0.5765	0.5973		1.0000	1.0000	1.0000	1.0000	1.0000
	0.6180	0.6387	0.6593	0.6799	0.7004		1.0000	1.0000	1.0000	1.0000	1.0000
	0.7208	0.7412	0.7615	0.7817	0.8019	Transect T_Major_Roads_25M_CURB_MEDIAN					
	0.8220	0.8420	0.8620	0.8819	0.9018	Area:					

	0.0032	0.0127	0.0256	0.0401	0.0558		0.4223	0.4438	0.4652	0.4866	0.5078
	0.0729	0.0912	0.1108	0.1316	0.1528		0.5289	0.5499	0.5708	0.5916	0.6122
	0.1740	0.1952	0.2163	0.2375	0.2587		0.6328	0.6532	0.6735	0.6936	0.7137
	0.2799	0.3011	0.3222	0.3434	0.3646		0.7336	0.7534	0.7730	0.7926	0.8120
	0.3858	0.4070	0.4281	0.4493	0.4705		0.8313	0.8505	0.8696	0.8886	0.9074
	0.4917	0.5129	0.5340	0.5552	0.5764		0.9262	0.9448	0.9633	0.9817	1.0000
	0.5976	0.6188	0.6399	0.6611	0.6823	Width:					
	0.7035	0.7247	0.7458	0.7670	0.7882		0.2000	0.2000	0.2480	0.3440	0.4400
	0.8094	0.8306	0.8517	0.8729	0.8941		0.5360	0.6320	0.7280	0.8240	0.9200
	0.9153	0.9365	0.9576	0.9788	1.0000		1.0000	1.0000	1.0000	1.0000	1.0000
Hrad:							1.0000	1.0000	1.0000	1.0000	1.0000
	0.0143	0.0297	0.0541	0.0795	0.1027		1.0000	1.0000	1.0000	1.0000	1.0000
	0.1241	0.1438	0.1623	0.1800	0.1995		1.0000	1.0000	1.0000	1.0000	1.0000
	0.2194	0.2397	0.2601	0.2806	0.3012		1.0000	1.0000	1.0000	1.0000	1.0000
	0.3218	0.3424	0.3630	0.3836	0.4042		1.0000	1.0000	1.0000	1.0000	1.0000
	0.4247	0.4452	0.4657	0.4861	0.5064		1.0000	1.0000	1.0000	1.0000	1.0000
	0.5268	0.5470	0.5672	0.5874	0.6075		1.0000	1.0000	1.0000	1.0000	1.0000
	0.6276	0.6476	0.6676	0.6875	0.7074						
	0.7272	0.7470	0.7667	0.7864	0.8060	Transect T_Major_Roads_5M_CURB_MEDIAN					
	0.8256	0.8452	0.8647	0.8841	0.9036	Area:	0.0043	0.0105	0.0185	0.0294	0.0418
	0.9229	0.9423	0.9615	0.9808	1.0000		0.0556	0.0710	0.0879	0.1062	0.1261
Width:							0.1474	0.1693	0.1912	0.2130	0.2349
	0.3000	0.5750	0.6550	0.7150	0.7750		0.2567	0.2786	0.3005	0.3223	0.3442
	0.8350	0.8950	0.9550	1.0000	1.0000		0.3660	0.3879	0.4098	0.4316	0.4535
	1.0000	1.0000	1.0000	1.0000	1.0000		0.4753	0.4972	0.5191	0.5409	0.5628
	1.0000	1.0000	1.0000	1.0000	1.0000		0.5846	0.6065	0.6284	0.6502	0.6721
	1.0000	1.0000	1.0000	1.0000	1.0000		0.6939	0.7158	0.7377	0.7595	0.7814
	1.0000	1.0000	1.0000	1.0000	1.0000		0.8033	0.8251	0.8470	0.8688	0.8907
	1.0000	1.0000	1.0000	1.0000	1.0000		0.9126	0.9344	0.9563	0.9781	1.0000
	1.0000	1.0000	1.0000	1.0000	1.0000	Hrad:					
	1.0000	1.0000	1.0000	1.0000	1.0000		0.0300	0.0720	0.1005	0.1207	0.1406
							0.1592	0.1764	0.1923	0.2074	0.2215
Transect T_Major_Roads_5M_CURB_FULL							0.2358	0.2547	0.2744	0.2947	0.3153
Area:							0.3361	0.3569	0.3779	0.3988	0.4197
	0.0031	0.0076	0.0123	0.0190	0.0277		0.4405	0.4613	0.4819	0.5025	0.5230
	0.0387	0.0518	0.0670	0.0844	0.1040		0.5434	0.5636	0.5838	0.6038	0.6238
	0.1256	0.1481	0.1705	0.1929	0.2153		0.6436	0.6633	0.6829	0.7024	0.7218
	0.2377	0.2602	0.2826	0.3050	0.3274		0.7411	0.7602	0.7793	0.7982	0.8171
	0.3498	0.3723	0.3947	0.4171	0.4395		0.8358	0.8544	0.8730	0.8914	0.9097
	0.4619	0.4844	0.5068	0.5292	0.5516		0.9280	0.9461	0.9642	0.9821	1.0000
	0.5740	0.5965	0.6189	0.6413	0.6637	Width:					
	0.6861	0.7085	0.7310	0.7534	0.7758		0.2857	0.2857	0.4629	0.5314	0.6000
	0.7982	0.8206	0.8431	0.8655	0.8879		0.6686	0.7371	0.8057	0.8743	0.9429
	0.9103	0.9327	0.9552	0.9776	1.0000		1.0000	1.0000	1.0000	1.0000	1.0000
Hrad:							1.0000	1.0000	1.0000	1.0000	1.0000
	0.0323	0.0775	0.1185	0.1425	0.1569		1.0000	1.0000	1.0000	1.0000	1.0000
	0.1676	0.1769	0.1857	0.1945	0.2032		1.0000	1.0000	1.0000	1.0000	1.0000
	0.2134	0.2318	0.2515	0.2720	0.2931		1.0000	1.0000	1.0000	1.0000	1.0000
	0.3144	0.3359	0.3575	0.3792	0.4008		1.0000	1.0000	1.0000	1.0000	1.0000





	1.0000	1.0000	1.0000	1.0000	1.0000		0.4809	0.5025	0.5242	0.5458	0.5674
	1.0000	1.0000	1.0000	1.0000	1.0000		0.5890	0.6107	0.6323	0.6539	0.6756
	1.0000	1.0000	1.0000	1.0000	1.0000		0.6972	0.7188	0.7405	0.7621	0.7837
	1.0000	1.0000	1.0000	1.0000	1.0000		0.8053	0.8270	0.8486	0.8702	0.8919
	1.0000	1.0000	1.0000	1.0000	1.0000		0.9135	0.9351	0.9567	0.9784	1.0000
	1.0000	1.0000	1.0000	1.0000	1.0000	Hrad:					
	1.0000	1.0000	1.0000	1.0000	1.0000		0.0197	0.0437	0.0801	0.1056	0.1240
	1.0000	1.0000	1.0000	1.0000	1.0000		0.1388	0.1514	0.1628	0.1804	0.1998
Transect T_Major_Roads_7M_CURB							0.2201	0.2410	0.2622	0.2835	0.3049
Area:							0.3263	0.3477	0.3690	0.3902	0.4114
	0.0018	0.0068	0.0123	0.0193	0.0279		0.4325	0.4535	0.4744	0.4952	0.5159
	0.0382	0.0501	0.0637	0.0790	0.0959		0.5365	0.5570	0.5774	0.5976	0.6178
	0.1145	0.1347	0.1566	0.1794	0.2022		0.6379	0.6578	0.6776	0.6974	0.7170
	0.2250	0.2478	0.2706	0.2934	0.3162		0.7366	0.7560	0.7753	0.7946	0.8137
	0.3390	0.3618	0.3846	0.4074	0.4302		0.8327	0.8517	0.8705	0.8893	0.9080
	0.4530	0.4758	0.4985	0.5213	0.5441		0.9266	0.9450	0.9635	0.9818	1.0000
	0.5669	0.5897	0.6125	0.6353	0.6581	Width:					
	0.6809	0.7037	0.7265	0.7493	0.7721		0.1920	0.3400	0.4000	0.5200	0.6400
	0.7949	0.8177	0.8404	0.8632	0.8860		0.7600	0.8800	1.0000	1.0000	1.0000
	0.9088	0.9316	0.9544	0.9772	1.0000		1.0000	1.0000	1.0000	1.0000	1.0000
Hrad:							1.0000	1.0000	1.0000	1.0000	1.0000
	0.0221	0.0556	0.0963	0.1260	0.1481		1.0000	1.0000	1.0000	1.0000	1.0000
	0.1659	0.1811	0.1947	0.2072	0.2190		1.0000	1.0000	1.0000	1.0000	1.0000
	0.2303	0.2412	0.2518	0.2698	0.2892		1.0000	1.0000	1.0000	1.0000	1.0000
	0.3093	0.3299	0.3507	0.3718	0.3929		1.0000	1.0000	1.0000	1.0000	1.0000
	0.4141	0.4354	0.4566	0.4778	0.4989		1.0000	1.0000	1.0000	1.0000	1.0000
	0.5200	0.5411	0.5621	0.5829	0.6037		1.0000	1.0000	1.0000	1.0000	1.0000
	0.6245	0.6451	0.6656	0.6861	0.7064						
	0.7267	0.7468	0.7669	0.7868	0.8067	Transect T_Major_Roads_8M_CURB					
	0.8264	0.8461	0.8657	0.8851	0.9045	Area:					
	0.9238	0.9430	0.9621	0.9811	1.0000		0.0018	0.0070	0.0132	0.0210	0.0305
Width:							0.0419	0.0551	0.0700	0.0868	0.1053
	0.1600	0.2333	0.2697	0.3424	0.4152		0.1256	0.1477	0.1701	0.1925	0.2150
	0.4879	0.5606	0.6333	0.7061	0.7788		0.2374	0.2598	0.2822	0.3047	0.3271
	0.8515	0.9242	0.9970	1.0000	1.0000		0.3495	0.3720	0.3944	0.4168	0.4393
	1.0000	1.0000	1.0000	1.0000	1.0000		0.4617	0.4841	0.5065	0.5290	0.5514
	1.0000	1.0000	1.0000	1.0000	1.0000		0.5738	0.5963	0.6187	0.6411	0.6636
	1.0000	1.0000	1.0000	1.0000	1.0000		0.6860	0.7084	0.7308	0.7533	0.7757
	1.0000	1.0000	1.0000	1.0000	1.0000		0.7981	0.8206	0.8430	0.8654	0.8879
	1.0000	1.0000	1.0000	1.0000	1.0000		0.9103	0.9327	0.9551	0.9776	1.0000
	1.0000	1.0000	1.0000	1.0000	1.0000	Hrad:					
	1.0000	1.0000	1.0000	1.0000	1.0000		0.0211	0.0490	0.0883	0.1173	0.1393
	1.0000	1.0000	1.0000	1.0000	1.0000		0.1572	0.1725	0.1861	0.1987	0.2105
Transect T_Major_Roads_8.5M_CURB							0.2217	0.2348	0.2534	0.2729	0.2931
Area:							0.3137	0.3346	0.3556	0.3767	0.3979
	0.0021	0.0082	0.0159	0.0258	0.0384		0.4191	0.4402	0.4613	0.4824	0.5034
	0.0535	0.0712	0.0916	0.1132	0.1348		0.5243	0.5452	0.5660	0.5867	0.6073
	0.1565	0.1781	0.1997	0.2214	0.2430		0.6278	0.6482	0.6686	0.6888	0.7090
	0.2646	0.2862	0.3079	0.3295	0.3511		0.7290	0.7490	0.7688	0.7886	0.8083
	0.3728	0.3944	0.4160	0.4376	0.4593		0.8279	0.8474	0.8667	0.8861	0.9053







	0.5056	0.5262	0.5468	0.5674	0.5880		0.9361	0.9523	0.9683	0.9842	1.0000
	0.6086	0.6292	0.6498	0.6704	0.6910						
	0.7116	0.7322	0.7528	0.7734	0.7940	Width:	0.7200	0.8400	0.9600	1.0000	1.0000
	0.8146	0.8352	0.8558	0.8764	0.8970		1.0000	1.0000	1.0000	1.0000	1.0000
Hrad:	0.9176	0.9382	0.9588	0.9794	1.0000		1.0000	1.0000	1.0000	1.0000	1.0000
	0.0131	0.0292	0.0496	0.0682	0.0926		1.0000	1.0000	1.0000	1.0000	1.0000
	0.1180	0.1431	0.1679	0.1925	0.2168		1.0000	1.0000	1.0000	1.0000	1.0000
	0.2407	0.2644	0.2879	0.3110	0.3340		1.0000	1.0000	1.0000	1.0000	1.0000
	0.3566	0.3790	0.4012	0.4231	0.4447		1.0000	1.0000	1.0000	1.0000	1.0000
	0.4662	0.4874	0.5083	0.5291	0.5496		1.0000	1.0000	1.0000	1.0000	1.0000
	0.5699	0.5900	0.6099	0.6296	0.6490		1.0000	1.0000	1.0000	1.0000	1.0000
	0.6683	0.6874	0.7063	0.7250	0.7434		1.0000	1.0000	1.0000	1.0000	1.0000
	0.7618	0.7799	0.7978	0.8156	0.8332						
	0.8506	0.8679	0.8849	0.9018	0.9186	Transect T_Major_RY_0.5m_12.5m					
	0.9352	0.9516	0.9679	0.9840	1.0000	Area:	0.0033	0.0129	0.0252	0.0391	0.0544
Width:							0.0713	0.0897	0.1096	0.1307	0.1519
	0.4200	0.7400	0.8600	0.9800	1.0000		0.1731	0.1943	0.2155	0.2367	0.2580
	1.0000	1.0000	1.0000	1.0000	1.0000		0.2792	0.3004	0.3216	0.3428	0.3640
	1.0000	1.0000	1.0000	1.0000	1.0000		0.3852	0.4064	0.4276	0.4488	0.4700
	1.0000	1.0000	1.0000	1.0000	1.0000		0.4912	0.5124	0.5336	0.5548	0.5760
	1.0000	1.0000	1.0000	1.0000	1.0000		0.5972	0.6184	0.6396	0.6608	0.6820
	1.0000	1.0000	1.0000	1.0000	1.0000		0.7032	0.7244	0.7456	0.7668	0.7880
	1.0000	1.0000	1.0000	1.0000	1.0000		0.8092	0.8304	0.8516	0.8728	0.8940
	1.0000	1.0000	1.0000	1.0000	1.0000	Hrad:	0.9152	0.9364	0.9576	0.9788	1.0000
	1.0000	1.0000	1.0000	1.0000	1.0000		0.0149	0.0334	0.0575	0.0796	0.1003
							0.1199	0.1388	0.1571	0.1816	0.2091
Transect T_Major_RY_0.2m_20m							0.2361	0.2625	0.2885	0.3140	0.3391
Area:							0.3637	0.3878	0.4116	0.4349	0.4578
	0.0084	0.0242	0.0426	0.0628	0.0832		0.4804	0.5025	0.5243	0.5458	0.5668
	0.1036	0.1239	0.1443	0.1647	0.1851		0.5876	0.6079	0.6280	0.6477	0.6672
	0.2054	0.2258	0.2462	0.2666	0.2869		0.6863	0.7051	0.7237	0.7419	0.7599
	0.3073	0.3277	0.3480	0.3684	0.3888		0.7776	0.7950	0.8122	0.8291	0.8458
	0.4092	0.4295	0.4499	0.4703	0.4907		0.8622	0.8784	0.8944	0.9101	0.9256
	0.5110	0.5314	0.5518	0.5722	0.5925		0.9409	0.9560	0.9709	0.9855	1.0000
	0.6129	0.6333	0.6537	0.6740	0.6944	Width:					
	0.7148	0.7351	0.7555	0.7759	0.7963		0.3120	0.5440	0.6160	0.6880	0.7600
	0.8166	0.8370	0.8574	0.8778	0.8981		0.8320	0.9040	0.9760	1.0000	1.0000
	0.9185	0.9389	0.9593	0.9796	1.0000		1.0000	1.0000	1.0000	1.0000	1.0000
Hrad:							1.0000	1.0000	1.0000	1.0000	1.0000
	0.0149	0.0369	0.0568	0.0801	0.1054		1.0000	1.0000	1.0000	1.0000	1.0000
	0.1305	0.1552	0.1797	0.2039	0.2277		1.0000	1.0000	1.0000	1.0000	1.0000
	0.2514	0.2747	0.2978	0.3206	0.3432		1.0000	1.0000	1.0000	1.0000	1.0000
	0.3655	0.3876	0.4094	0.4310	0.4524		1.0000	1.0000	1.0000	1.0000	1.0000
	0.4735	0.4944	0.5151	0.5355	0.5558		1.0000	1.0000	1.0000	1.0000	1.0000
	0.5758	0.5956	0.6152	0.6346	0.6538		1.0000	1.0000	1.0000	1.0000	1.0000
	0.6728	0.6916	0.7102	0.7287	0.7469		1.0000	1.0000	1.0000	1.0000	1.0000
	0.7650	0.7828	0.8005	0.8181	0.8354						
	0.8526	0.8696	0.8865	0.9032	0.9197	Transect T_Major_RY_0.5m_15m					
						Area:					

	0.0019	0.0077	0.0174	0.0304	0.0452		0.4461	0.4681	0.4900	0.5115	0.5329
	0.0618	0.0801	0.1001	0.1214	0.1429		0.5540	0.5749	0.5955	0.6160	0.6362
	0.1643	0.1857	0.2071	0.2286	0.2500		0.6562	0.6760	0.6956	0.7150	0.7342
	0.2714	0.2929	0.3143	0.3357	0.3571		0.7532	0.7720	0.7906	0.8090	0.8273
	0.3786	0.4000	0.4214	0.4429	0.4643		0.8453	0.8632	0.8809	0.8984	0.9158
	0.4857	0.5071	0.5286	0.5500	0.5714		0.9329	0.9499	0.9668	0.9835	1.0000
	0.5929	0.6143	0.6357	0.6571	0.6786	Width:					
	0.7000	0.7214	0.7429	0.7643	0.7857		0.3000	0.5250	0.6000	0.6750	0.7500
	0.8071	0.8286	0.8500	0.8714	0.8929		0.8250	0.9000	0.9750	1.0000	1.0000
	0.9143	0.9357	0.9571	0.9786	1.0000		1.0000	1.0000	1.0000	1.0000	1.0000
Hrad:							1.0000	1.0000	1.0000	1.0000	1.0000
	0.0143	0.0286	0.0429	0.0620	0.0823		1.0000	1.0000	1.0000	1.0000	1.0000
	0.1013	0.1195	0.1370	0.1609	0.1879		1.0000	1.0000	1.0000	1.0000	1.0000
	0.2143	0.2404	0.2661	0.2914	0.3163		1.0000	1.0000	1.0000	1.0000	1.0000
	0.3408	0.3650	0.3888	0.4122	0.4354		1.0000	1.0000	1.0000	1.0000	1.0000
	0.4581	0.4806	0.5027	0.5245	0.5460		1.0000	1.0000	1.0000	1.0000	1.0000
	0.5672	0.5882	0.6088	0.6291	0.6492		1.0000	1.0000	1.0000	1.0000	1.0000
	0.6690	0.6885	0.7078	0.7268	0.7455		1.0000	1.0000	1.0000	1.0000	1.0000
	0.7641	0.7823	0.8004	0.8182	0.8358	Transect T_Major_RY_0.7m_25m					
	0.8531	0.8703	0.8872	0.9039	0.9204	Area:					
	0.9367	0.9528	0.9687	0.9845	1.0000		0.0020	0.0078	0.0176	0.0307	0.0449
Width:							0.0602	0.0766	0.0940	0.1124	0.1319
	0.1800	0.3600	0.5400	0.6533	0.7333		0.1524	0.1739	0.1957	0.2174	0.2391
	0.8133	0.8933	0.9733	1.0000	1.0000		0.2609	0.2826	0.3043	0.3261	0.3478
	1.0000	1.0000	1.0000	1.0000	1.0000		0.3696	0.3913	0.4130	0.4348	0.4565
	1.0000	1.0000	1.0000	1.0000	1.0000		0.4783	0.5000	0.5217	0.5435	0.5652
	1.0000	1.0000	1.0000	1.0000	1.0000		0.5870	0.6087	0.6304	0.6522	0.6739
	1.0000	1.0000	1.0000	1.0000	1.0000		0.6957	0.7174	0.7391	0.7609	0.7826
	1.0000	1.0000	1.0000	1.0000	1.0000		0.8043	0.8261	0.8478	0.8696	0.8913
	1.0000	1.0000	1.0000	1.0000	1.0000		0.9130	0.9348	0.9565	0.9783	1.0000
	1.0000	1.0000	1.0000	1.0000	1.0000	Hrad:					
	1.0000	1.0000	1.0000	1.0000	1.0000		0.0129	0.0258	0.0387	0.0575	0.0783
	1.0000	1.0000	1.0000	1.0000	1.0000		0.0980	0.1169	0.1351	0.1526	0.1697
Transect T_Major_RY_0.5m_20m							0.1864	0.2055	0.2301	0.2545	0.2786
Area:							0.3025	0.3262	0.3496	0.3729	0.3959
	0.0032	0.0125	0.0244	0.0380	0.0531		0.4187	0.4413	0.4637	0.4859	0.5079
	0.0698	0.0881	0.1081	0.1292	0.1504		0.5297	0.5513	0.5727	0.5940	0.6150
	0.1717	0.1929	0.2142	0.2354	0.2566		0.6358	0.6565	0.6770	0.6973	0.7175
	0.2779	0.2991	0.3204	0.3416	0.3628		0.7374	0.7572	0.7769	0.7963	0.8156
	0.3841	0.4053	0.4265	0.4478	0.4690		0.8347	0.8537	0.8725	0.8912	0.9097
	0.4903	0.5115	0.5327	0.5540	0.5752		0.9281	0.9463	0.9643	0.9822	1.0000
	0.5965	0.6177	0.6389	0.6602	0.6814	Width:					
	0.7027	0.7239	0.7451	0.7664	0.7876		0.1800	0.3600	0.5400	0.6320	0.6800
	0.8088	0.8301	0.8513	0.8726	0.8938		0.7280	0.7760	0.8240	0.8720	0.9200
	0.9150	0.9363	0.9575	0.9788	1.0000		0.9680	1.0000	1.0000	1.0000	1.0000
Hrad:							1.0000	1.0000	1.0000	1.0000	1.0000
	0.0133	0.0297	0.0509	0.0703	0.0885		1.0000	1.0000	1.0000	1.0000	1.0000
	0.1058	0.1224	0.1385	0.1608	0.1861		1.0000	1.0000	1.0000	1.0000	1.0000
	0.2112	0.2359	0.2603	0.2845	0.3084		1.0000	1.0000	1.0000	1.0000	1.0000
	0.3320	0.3553	0.3784	0.4012	0.4238		1.0000	1.0000	1.0000	1.0000	1.0000

	1.0000	1.0000	1.0000	1.0000	1.0000
	1.0000	1.0000	1.0000	1.0000	1.0000
Transect T_Major_Watercourse_1					
Area:	0.0005	0.0018	0.0042	0.0073	0.0110
	0.0153	0.0201	0.0254	0.0312	0.0375
	0.0444	0.0517	0.0595	0.0679	0.0766
	0.0859	0.0957	0.1059	0.1165	0.1277
	0.1393	0.1514	0.1640	0.1770	0.1906
	0.2048	0.2198	0.2357	0.2539	0.2732
	0.2935	0.3153	0.3387	0.3642	0.3921
	0.4217	0.4548	0.4962	0.5382	0.5802
	0.6222	0.6642	0.7061	0.7481	0.7901
	0.8321	0.8741	0.9160	0.9580	1.0000
Hrad:	0.0197	0.0394	0.0592	0.0832	0.1072
	0.1313	0.1542	0.1763	0.1979	0.2190
	0.2396	0.2610	0.2821	0.3029	0.3234
	0.3438	0.3640	0.3849	0.4054	0.4250
	0.4444	0.4638	0.4831	0.5024	0.5201
	0.5295	0.5382	0.5364	0.5159	0.5273
	0.5354	0.5381	0.5374	0.5221	0.5306
	0.5326	0.5088	0.5394	0.5732	0.6091
	0.6464	0.6847	0.7235	0.7628	0.8023
	0.8419	0.8815	0.9211	0.9606	1.0000
Width:	0.0220	0.0440	0.0660	0.0818	0.0956
	0.1079	0.1201	0.1324	0.1447	0.1569
	0.1693	0.1808	0.1922	0.2036	0.2151
	0.2265	0.2379	0.2486	0.2595	0.2710
	0.2824	0.2939	0.3054	0.3168	0.3293
	0.3482	0.3684	0.3977	0.4479	0.4723
	0.5008	0.5366	0.5790	0.6435	0.6830
	0.7338	0.9296	1.0000	1.0000	1.0000
	1.0000	1.0000	1.0000	1.0000	1.0000
	1.0000	1.0000	1.0000	1.0000	1.0000

Transect T_Major_Watercourse_Ramp					
Area:	0.0005	0.0016	0.0031	0.0049	0.0070
	0.0094	0.0120	0.0149	0.0180	0.0214
	0.0250	0.0288	0.0328	0.0371	0.0416
	0.0463	0.0512	0.0563	0.0617	0.0674
	0.0734	0.0797	0.0865	0.0946	0.1039
	0.1147	0.1262	0.1399	0.1579	0.1869
	0.2219	0.2605	0.3014	0.3425	0.3836
	0.4247	0.4658	0.5069	0.5480	0.5890
	0.6301	0.6712	0.7123	0.7534	0.7945
	0.8356	0.8767	0.9178	0.9589	1.0000

Hrad:	0.0573	0.1418	0.2143	0.2820	0.3516
	0.4179	0.4818	0.5502	0.6163	0.6816
	0.7455	0.8081	0.8696	0.9303	0.9926
	1.0597	1.1106	1.1610	1.2118	1.2629
	1.3049	1.3352	1.3656	1.2257	1.1010
	1.1504	1.1632	1.1089	1.1271	0.8066
	0.2651	0.2987	0.3128	0.3547	0.3963
	0.4378	0.4791	0.5203	0.5612	0.6020
	0.6426	0.6830	0.7232	0.7633	0.8032
	0.8429	0.8824	0.9218	0.9610	1.0000
Width:	0.0237	0.0318	0.0398	0.0476	0.0543
	0.0610	0.0677	0.0734	0.0790	0.0845
	0.0900	0.0955	0.1010	0.1065	0.1116
	0.1160	0.1224	0.1288	0.1353	0.1417
	0.1494	0.1587	0.1776	0.2072	0.2553
	0.2701	0.3092	0.3591	0.5261	0.8186
	0.8946	0.9705	1.0000	1.0000	1.0000
	1.0000	1.0000	1.0000	1.0000	1.0000
	1.0000	1.0000	1.0000	1.0000	1.0000
	1.0000	1.0000	1.0000	1.0000	1.0000

Transect T_Parking_Lot					
Area:	0.0025	0.0100	0.0225	0.0401	0.0609
	0.0817	0.1026	0.1235	0.1443	0.1652
	0.1861	0.2070	0.2278	0.2487	0.2696
	0.2904	0.3113	0.3322	0.3530	0.3739
	0.3948	0.4157	0.4365	0.4574	0.4783
	0.4991	0.5200	0.5409	0.5617	0.5826
	0.6035	0.6243	0.6452	0.6661	0.6870
	0.7078	0.7287	0.7496	0.7704	0.7913
	0.8122	0.8330	0.8539	0.8748	0.8957
	0.9165	0.9374	0.9583	0.9791	1.0000
Hrad:	0.0133	0.0266	0.0399	0.0532	0.0772
	0.1031	0.1286	0.1539	0.1788	0.2035
	0.2279	0.2520	0.2758	0.2994	0.3227
	0.3457	0.3685	0.3910	0.4133	0.4354
	0.4572	0.4787	0.5000	0.5211	0.5420
	0.5627	0.5831	0.6033	0.6233	0.6431
	0.6627	0.6821	0.7013	0.7203	0.7391
	0.7577	0.7762	0.7944	0.8125	0.8304
	0.8481	0.8656	0.8830	0.9002	0.9172
	0.9341	0.9508	0.9674	0.9838	1.0000
Width:	0.2400	0.4800	0.7200	0.9600	1.0000
	1.0000	1.0000	1.0000	1.0000	1.0000
	1.0000	1.0000	1.0000	1.0000	1.0000

1.0000	1.0000	1.0000	1.0000	1.0000
1.0000	1.0000	1.0000	1.0000	1.0000
1.0000	1.0000	1.0000	1.0000	1.0000
1.0000	1.0000	1.0000	1.0000	1.0000
1.0000	1.0000	1.0000	1.0000	1.0000
1.0000	1.0000	1.0000	1.0000	1.0000
1.0000	1.0000	1.0000	1.0000	1.0000

Transect T\_RY\_Rockway\_Pond  
Area:

0.0037	0.0145	0.0271	0.0402	0.0536
0.0674	0.0816	0.0961	0.1110	0.1263
0.1419	0.1580	0.1744	0.1911	0.2082
0.2258	0.2436	0.2619	0.2805	0.2995
0.3188	0.3386	0.3587	0.3792	0.4000
0.4212	0.4428	0.4648	0.4871	0.5098
0.5329	0.5563	0.5801	0.6043	0.6289
0.6536	0.6784	0.7031	0.7278	0.7526
0.7773	0.8021	0.8268	0.8515	0.8763
0.9010	0.9258	0.9505	0.9753	1.0000

Hrad:

0.0130	0.0302	0.0550	0.0791	0.1026
0.1256	0.1479	0.1698	0.1913	0.2123
0.2329	0.2532	0.2731	0.2927	0.3121
0.3311	0.3499	0.3684	0.3867	0.4048
0.4227	0.4404	0.4579	0.4752	0.4924
0.5094	0.5263	0.5430	0.5597	0.5761
0.5925	0.6088	0.6249	0.6409	0.6569
0.6807	0.7044	0.7279	0.7513	0.7746
0.7977	0.8207	0.8436	0.8663	0.8889
0.9114	0.9337	0.9560	0.9780	1.0000

Width:

0.3000	0.5050	0.5200	0.5350	0.5500
0.5650	0.5800	0.5950	0.6100	0.6250
0.6400	0.6550	0.6700	0.6850	0.7000
0.7150	0.7300	0.7450	0.7600	0.7750
0.7900	0.8050	0.8200	0.8350	0.8500
0.8650	0.8800	0.8950	0.9100	0.9250
0.9400	0.9550	0.9700	0.9850	1.0000
1.0000	1.0000	1.0000	1.0000	1.0000
1.0000	1.0000	1.0000	1.0000	1.0000
1.0000	1.0000	1.0000	1.0000	1.0000

\*\*\*\*\*

Rainfall File Summary

\*\*\*\*\*

Station ID	First Date	Last Date	Recording Frequency	Periods w/Precip	Periods Missing	Periods Malfunc.
------------	------------	-----------	---------------------	------------------	-----------------	------------------

-----

100yr_3hr_Chicago	11/10/2013	11/10/2013	10 min	18	0
0					
100yr_6hr_Chicago	11/10/2013	11/10/2013	10 min	36	0
0					
100yrChicago12hr	11/10/2013	11/10/2013	10 min	73	0
0					
100yrChicago24hr	11/10/2013	11/11/2013	10 min	145	0
0					
10yr_3hr_Chicago	11/10/2013	11/10/2013	10 min	18	0
0					
10yr_6hr_Chicago	11/10/2013	11/10/2013	10 min	36	0
0					
10yrChicago24hr	11/10/2013	11/11/2013	10 min	145	0
0					
5yrChicago3hr	11/10/2013	11/10/2013	10 min	19	0
0					
5yrChicago12hr	11/10/2013	11/10/2013	10 min	73	0
0					
5yrChicago24hr	11/10/2013	11/11/2013	10 min	145	0
0					
5yrChicago3hr	11/10/2013	11/10/2013	10 min	19	0
0					
5yrChicago6hr	11/10/2013	11/10/2013	10 min	37	0
0					

\*\*\*\*\*  
NOTE: The summary statistics displayed in this report are based on results found at every computational time step, not just on results from each reporting time step.  
\*\*\*\*\*

\*\*\*\*\*

Analysis Options

\*\*\*\*\*

Flow Units ..... CMS

Process Models:

Rainfall/Runoff ..... YES  
RDII ..... NO  
Snowmelt ..... NO  
Groundwater ..... NO  
Flow Routing ..... YES  
Ponding Allowed ..... YES  
Water Quality ..... NO

Infiltration Method ..... HORTON

Flow Routing Method ..... DYNWAVE

Surcharge Method ..... EXTRAN

Starting Date ..... 11/10/2013 00:00:00

Ending Date ..... 11/13/2013 00:00:00

Antecedent Dry Days ..... 0.0



Report Time Step ..... 00:00:30  
 Wet Time Step ..... 00:05:00  
 Dry Time Step ..... 00:05:00  
 Routing Time Step ..... 1.00 sec  
 Variable Time Step ..... YES  
 Maximum Trials ..... 20  
 Number of Threads ..... 2  
 Head Tolerance ..... 0.001500 m

```

*****
Volume      Depth
Runoff Quantity Continuity  hectare-m      mm
*****
Total Precipitation ..... 0.126      74.345
Evaporation Loss ..... 0.000      0.000
Infiltration Loss ..... 0.050      29.759
Surface Runoff ..... 0.075      44.242
Final Storage ..... 0.001      0.608
Continuity Error (%) ..... -0.356
  
```

```

*****
Volume      Volume
Flow Routing Continuity  hectare-m      10^6 ltr
*****
Dry Weather Inflow ..... 0.000      0.000
Wet Weather Inflow ..... 0.075      0.749
Groundwater Inflow ..... 0.000      0.000
RDII Inflow ..... 0.000      0.000
External Inflow ..... 0.000      0.000
External Outflow ..... 0.075      0.749
Flooding Loss ..... 0.000      0.000
Evaporation Loss ..... 0.000      0.000
Exfiltration Loss ..... 0.000      0.000
Initial Stored Volume .... 0.000      0.000
Final Stored Volume ..... 0.000      0.000
Continuity Error (%) ..... -0.087
  
```

```

*****
Time-Step Critical Elements
*****
None
  
```

```

*****
Highest Flow Instability Indexes
*****
Link OR1 (2)
  
```

```

*****
Routing Time Step Summary
*****
Minimum Time Step      : 0.37 sec
Average Time Step      : 1.00 sec
Maximum Time Step      : 1.00 sec
Percent in Steady State : 0.00
Average Iterations per Step : 2.00
Percent Not Converging  : 0.00
Time Step Frequencies  :
  1.000 - 0.871 sec    : 100.00 %
  0.871 - 0.758 sec    : 0.00 %
  0.758 - 0.660 sec    : 0.00 %
  0.660 - 0.574 sec    : 0.00 %
  0.574 - 0.500 sec    : 0.00 %
  
```

```

*****
Subcatchment Runoff Summary
*****
  
```

-----						
Perv	Total	Total	Total	Total	Total	Imperv
Runoff	Runoff	Peak	Runoff	Evap	Infil	Runoff
Subcatchment	Subcatchment	Precip	Runoff	Coeff	mm	mm
mm	mm	10^6 ltr	mm	mm	mm	mm
-----						
B-101		74.34	0.00	0.00	51.97	17.56
4.57	22.13	0.03	0.01	0.298		
B-102		74.34	0.00	0.00	17.25	51.85
4.50	56.36	0.02	0.01	0.758		
B-103		74.34	0.00	0.00	36.72	29.95
7.28	37.23	0.05	0.03	0.501		
B-104		74.34	0.00	0.00	2.92	69.49
0.89	70.38	0.04	0.02	0.947		
B-105		74.34	0.00	0.00	4.09	68.03
1.21	69.24	0.08	0.04	0.931		
B-106		74.34	0.00	0.00	2.33	70.25
0.71	70.96	0.09	0.04	0.954		
B-107		74.34	0.00	0.00	14.99	54.85
3.73	58.58	0.09	0.05	0.788		
B-108		74.34	0.00	0.00	1.74	70.89
0.58	71.47	0.05	0.02	0.961		
B-109		74.34	0.00	0.00	45.78	18.21

10.23	28.43	0.00	0.00	0.382				
B-110		74.34	0.00	0.00	0.00	56.54	8.01	
9.77	17.78	0.00	0.00	0.239				
B-111		74.34	0.00	0.00	0.00	23.59	44.57	
5.56	50.13	0.02	0.01	0.674				
B-112		74.34	0.00	0.00	0.00	46.56	18.96	
8.59	27.55	0.01	0.00	0.371				
B-113		74.34	0.00	0.00	0.00	0.00	73.17	
0.00	73.17	0.00	0.00	0.984				
B-114		74.34	0.00	0.00	0.00	0.00	73.17	
0.00	73.17	0.00	0.00	0.984				
B-BLDG		74.34	0.00	0.00	0.00	0.00	74.69	
0.00	74.69	0.21	0.08	1.005				
B-EXT1		74.34	0.00	0.00	0.00	67.91	0.00	
6.48	6.48	0.03	0.01	0.087				

\*\*\*\*\*  
Node Depth Summary  
\*\*\*\*\*

Reported		Average	Maximum	Maximum	Time of Max	
Depth		Depth	Depth	HGL	Occurrence	Max
Node	Type	Meters	Meters	Meters	days hr:min	
Meters						
B01	JUNCTION	0.01	0.72	100.90	0 08:29	
0.42						
CB202	JUNCTION	0.00	0.05	101.72	0 08:30	
0.05						
CBMH206	JUNCTION	0.03	0.90	100.40	0 08:45	
0.90						
CBMH207	JUNCTION	0.02	0.82	100.40	0 08:45	
0.82						
CBMH209	JUNCTION	0.01	0.61	100.61	0 08:29	
0.40						
CBMH210	JUNCTION	0.01	0.56	100.50	0 08:29	
0.50						
CBMH211	JUNCTION	0.01	0.64	100.71	0 08:29	
0.48						
CisternDS	JUNCTION	0.02	0.17	99.47	0 08:47	
0.17						
RYCB213	JUNCTION	0.00	0.05	101.90	0 08:30	
0.05						
STMH202	JUNCTION	0.01	0.13	99.36	0 08:49	

0.13								
STMH205	JUNCTION	0.03	0.99	100.40	0 08:47			
0.99								
STMH208	JUNCTION	0.02	0.71	100.41	0 08:45			
0.71								
CanadianShieldAve_DICB	OUTFALL	0.00	0.00	0.00	0 00:00			
0.00								
Cordillera_Major	OUTFALL	0.00	0.00	0.00	0 00:00			
0.00								
Cordillera_Minor	OUTFALL	0.01	0.13	99.07	0 08:49			
0.13								
BLDG	STORAGE	0.02	0.12	110.12	0 09:31			
0.12								
Cistern	STORAGE	0.04	1.09	100.39	0 08:47			
1.09								

\*\*\*\*\*  
Node Inflow Summary  
\*\*\*\*\*

Total	Flow	Maximum	Maximum	Time of Max	Lateral
Inflow	Balance	Lateral	Total	Occurrence	Inflow
Volume	Error	Inflow	Inflow	days hr:min	Volume
Node	Percent	CMS	CMS		10^6 ltr
10^6 ltr		Type			
B01		JUNCTION	0.026	0 08:30	0.0545
0.0545	0.062				
CB202		JUNCTION	0.000	0 08:30	0
0.0106	0.008				
CBMH206		JUNCTION	0.000	0 08:30	0
0.294	-0.257				
CBMH207		JUNCTION	0.041	0 08:30	0.0874
0.294	0.074				
CBMH209		JUNCTION	0.012	0 08:30	0.0235
0.0235	0.249				
CBMH210		JUNCTION	0.040	0 08:30	0.0839
0.183	0.152				
CBMH211		JUNCTION	0.021	0 08:30	0.045
0.0994	0.110				
CisternDS		JUNCTION	0.000	0 08:47	0

```

0.477      0.000
RYCB213    JUNCTION    0.005    0.005    0 08:30    0.0106
0.0106     0.007
STMH202    JUNCTION    0.000    0.050    0 08:49     0
0.683     0.001
STMH205    JUNCTION    0.026    0.172    0 08:30    0.0547
0.36      -0.087
STMH208    JUNCTION    0.000    0.100    0 08:30     0
0.206     -0.102
CanadianShieldAve_DICB 0.020    0.020    0 08:30    0.0609
0.0609     0.000
Cordillera_Major 0.002    0.002    0 08:30    0.00524
0.00524     0.000
Cordillera_Minor 0.000    0.050    0 08:49     0
0.683     0.000
BLDG       STORAGE     0.083    0.083    0 08:30    0.206
0.206     -0.001
Cistern    STORAGE     0.058    0.226    0 08:30    0.117
0.477     -0.016

```

\*\*\*\*\*  
Node Surcharge Summary  
\*\*\*\*\*

Surcharging occurs when water rises above the top of the highest conduit.

Node	Type	Hours Surcharged	Max. Height Above Crown Meters	Min. Depth Below Rim Meters
B01	JUNCTION	0.05	0.470	3.899
CBMH206	JUNCTION	1.24	0.430	2.710
CBMH207	JUNCTION	1.13	0.373	3.047
CBMH209	JUNCTION	0.69	0.360	3.376
CBMH210	JUNCTION	0.74	0.265	3.469
CBMH211	JUNCTION	0.50	0.360	4.089
STMH208	JUNCTION	0.90	0.258	3.635

\*\*\*\*\*  
Node Flooding Summary  
\*\*\*\*\*

No nodes were flooded.

\*\*\*\*\*  
Storage Volume Summary  
\*\*\*\*\*

```

-----
-----
of Max      Maximum      Average      Avg  Evap  Exfil      Maximum      Max      Time
                               Volume      Pcnt  Pcnt  Pcnt      Volume      Pcnt
Occurrence  Outflow
Storage Unit 1000 m3     Full  Loss  Loss      1000 m3     Full  days
hr:min      CMS
-----
-----
BLDG       0.009      1    0    0      0.102      12    0
09:31     0.006
Cistern    0.004      2    0    0      0.152      70    0
08:47     0.045

```

\*\*\*\*\*  
Outfall Loading Summary  
\*\*\*\*\*

```

-----
-----
Outfall Node      Flow Freq      Avg      Max      Total
                  Pcnt      CMS      CMS      Volume
                  10^6 ltr
-----
CanadianShieldAve_DICB 29.99    0.001    0.020    0.061
Cordillera_Major      7.53     0.000    0.002    0.005
Cordillera_Minor      38.05    0.007    0.050    0.683
-----
System              25.19    0.008    0.066    0.749

```

\*\*\*\*\*  
Link Flow Summary  
\*\*\*\*\*

```

-----
-----
Link      Type      Maximum |Flow|      Time of Max      Maximum      Max/      Max/
                  CMS      days hr:min      |Veloc|      Full      Full
                  m/sec      Flow      Depth
-----
C1        CONDUIT    0.169      0 08:30      1.06      1.07      1.00
C10       CONDUIT    0.026      0 08:30      0.69      0.62      1.00
C11       CONDUIT    0.045      0 08:47      1.02      0.59      0.44
C13       CONDUIT    0.050      0 08:49      1.79      0.37      0.42
C14       CONDUIT    0.005      0 08:30      0.76      0.15      0.27
C15       CONDUIT    0.005      0 08:30      0.91      0.12      0.23

```

C3	CONDUIT	0.142	0	08:30	1.01	1.00	1.00
C4	CONDUIT	0.141	0	08:30	1.08	0.99	1.00
C5	CONDUIT	0.100	0	08:30	1.15	1.04	1.00
C6	CONDUIT	0.013	0	08:29	0.72	0.25	1.00
C8	CONDUIT	0.088	0	08:30	1.34	1.29	1.00
C9	CONDUIT	0.048	0	08:30	0.98	1.13	1.00
OR1	ORIFICE	0.045	0	08:47			1.00
W1	WEIR	0.000	0	00:00			0.00
OL1	DUMMY	0.006	0	09:31			

0.00

\*\*\*\*\*  
 Conduit Surcharge Summary  
 \*\*\*\*\*

\*\*\*\*\*  
 Flow Classification Summary  
 \*\*\*\*\*

Conduit	Hours Full			Hours	Hours
	Both Ends	Upstream	Dnstream	Above Full Normal Flow	Capacity Limited
C1	1.47	1.47	1.72	0.01	0.01
C10	0.05	0.05	0.50	0.01	0.01
C3	1.28	1.28	1.34	0.01	0.01
C4	1.13	1.13	1.24	0.01	0.01
C5	1.05	1.05	1.13	0.01	0.01
C6	0.69	0.69	1.05	0.01	0.01
C8	0.74	0.74	0.90	0.12	0.05
C9	0.58	0.58	0.74	0.07	0.03

-----  
 ---

Inlet Conduit Ctrl	Adjusted /Actual Length	Fraction of Time in Flow Class							
		Up Dry	Down Dry	Sub Dry	Sup Crit	Up Crit	Down Crit	Norm Ltd	
C1	1.00	0.03	0.00	0.00	0.35	0.00	0.00	0.62	0.26
C10	1.00	0.03	0.00	0.00	0.01	0.00	0.00	0.95	0.00
C11	1.00	0.03	0.00	0.00	0.00	0.00	0.00	0.97	0.00
C13	1.00	0.00	0.00	0.00	0.36	0.64	0.00	0.00	0.08
C14	1.00	0.03	0.00	0.00	0.00	0.00	0.00	0.97	0.00
C15	1.00	0.03	0.00	0.00	0.00	0.00	0.00	0.97	0.00
C3	1.00	0.03	0.00	0.00	0.04	0.00	0.00	0.93	0.00
C4	1.00	0.03	0.00	0.00	0.03	0.00	0.00	0.93	0.00
C5	1.00	0.03	0.00	0.00	0.03	0.00	0.00	0.94	0.00
C6	1.00	0.03	0.00	0.00	0.02	0.00	0.00	0.95	0.01
C8	1.00	0.03	0.00	0.00	0.02	0.00	0.00	0.95	0.00
C9	1.00	0.03	0.00	0.00	0.02	0.00	0.00	0.95	0.00

Analysis begun on: Thu May 27 21:49:07 2021  
 Analysis ended on: Thu May 27 21:49:24 2021  
 Total elapsed time: 00:00:17