

Serial No. \_\_\_\_\_

# Sun-Mar

*Global Composting Experts*

## SELF CONTAINED TOILET OWNER'S MANUAL



EXCEL



EXCEL NE



COMPACT



Certified to NSF/ANSI Standard 41  
Certified for liquid containment,  
odors, and solid end products in  
both residential and cottage use

## **RATED CAPACITY**

### Residential & Continuous Use

EXCEL 3 Adults or a family  
EXCEL NE 2 Adults or families of 3  
COMPACT 1 Adult

### Weekend & Vacation Use

EXCEL 6 Adults or families of 8  
EXCEL NE 5 Adults or families of 7  
COMPACT 3 Adults or families of 4

### Models for which the manual applies:

CSEL-01001 Excel Bone 115 V  
CSEL-01001W Excel White 115 V  
CSEL-01001-230 Excel Bone 230 V  
CSEL-01001W-230 Excel White 230 V  
CSNL-01101B Excel NE Bone  
CSNL-01101W Excel NE White  
CSEM-01400B Compact Bone  
CSEM-01400WB Compact White  
CSEM-01400BB Compact Bone - 230 V  
CSEM-01400WBB Compact White - 230 V

## TABLE OF CONTENTS

The Self Contained Toilet	1	Compost Troubleshooting	14
The Patented Bio-drum™	1	Compost Too Wet	14
Compost Finishing Drawer	1	Waste Not Breaking Down	14
Evaporation Chamber	1	Lumps In Drum	14
How Composting Works	2	Bio-drum™ Too Full	14
		Strong Odor	14
		Flies Present	14
What's In The Box?	3		
Parts And Functionality	3		
Installing The Excel Footrest	3	Mechanical Troubleshooting	15
Installation FAQ	4	Urine Odor In Washroom	15
Rough-In Diagrams	5	Occasional Urine Odor Outside	15
Installation Specifications	6	Fan Noisy	16
EXCEL And COMPACT	6	Fan Not Working	16
EXCEL NE	6	Liquid Build-Up In Evaporation Chamber	16
Space Required And Other Considerations	6	Liquid Overflow	16
		Heating System Not Working/ Lack Of Evaporation	17
		Liquid In Finishing Drawer	18
Vent Pipe Installation		Drum Will Not Turn	18
EXCEL And COMPACT	7	Drum Door Not Opening/Closing Properly	18
EXCEL NE (Non-Electric)	8		
Inlet Coupling	8		
Diffuser Installation	8		
Drain Installation	8	COMPACT Explosion Diagram	19
Effluent Handling	9	Wiring Diagram/Electrical Specifications	
	9		
		EXCEL & EXCEL NE Explosion Diagram	20
Initial Start-Up And Use	10	Wiring Diagram/Electrical Specifications	
Ongoing Toilet Maintenance	11		
Removing Compost From The Bio-drum™	12	Composting Toilet Accessories	21
Seasonal Usage And Spring Start-Up	12		
Winter Use	13		



**Do NOT stand on the toilet.**

**Electric toilets must be installed so that electrical components of the toilet are protected from rain, flooding and melting snow.**

**Do NOT power wash electric toilets.**

**Using metal tools for cleaning purposes will damage the toilet.**



## The SUN-MAR SELF CONTAINED TOILET

The key to the success lies in its three chamber design. Each of the three chambers; patented Bio-drum™, compost finishing drawer, and evaporation chamber, have their own independent environments for optimum efficiency. The electric version has a thermostatically controlled heater and fan assembly to help evaporate liquid and should be used where there is a constant electrical supply. The non-electric version is for use where there is no continuous electric supply, and has no fan or heater.

### The Patented Bio-Drum™

Unique to Sun-Mar, the patented Bio-drum™ provides the necessary mass to maintain good compost and allows easy aeration of the compost by simply turning the drum. Excess liquid will exit through a screen in the bottom of the drum into the evaporation chamber. Mixing compost in the Bio-drum™ is accomplished by rotating the handle in a clock-wise direction. Compost is removed from the drum by pulling out the drum lock button and rotating the handle in a counter clock-wise direction.

### The Compost Finishing Drawer

The compost finishing drawer sits below the Bio-drum™ of the toilet. Compost in the drawer is isolated from mixing with new waste while resting for 4 weeks so that it can finish composting.

### The Evaporation Chamber

The evaporation chamber is the floor of the unit under the compost finishing drawer. This is the area where any excess liquid will gather for evaporation.

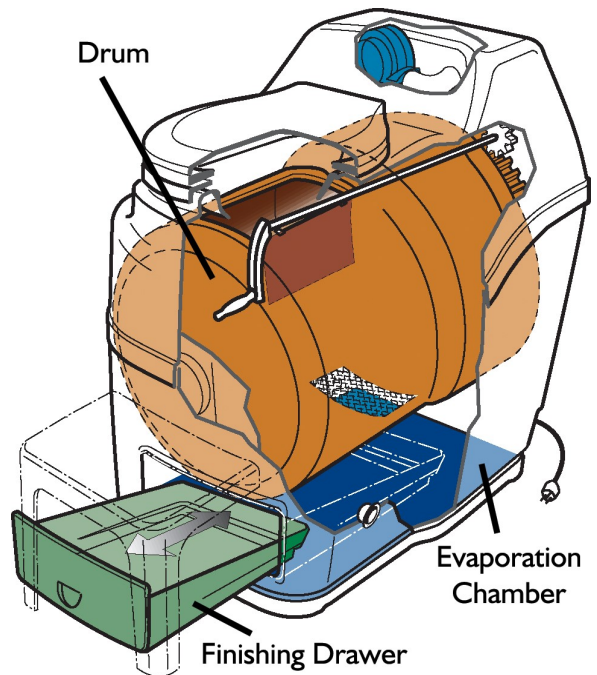

# HOW COMPOSTING WORKS

Composting is the natural process of decomposition that can be assisted by providing the ideal conditions to help your composting toilet work at peak performance. The ideal conditions for decomposition to occur depend on several factors: oxygen, temperature, moisture content, and the carbon/nitrogen ratio.

## **Oxygen**

Oxygen is very important in composting. Your compost should be aerated in order to encourage aerobic bacteria growth. Aerobic bacteria are bacteria that grow and live in the presence of oxygen and are very efficient in breaking down waste. To aerate the compost and encourage the growth of these bacteria, the compost drum should be turned three times per week (6 complete turns of the drum).

## **Temperature**

Temperature is another important consideration when composting. Optimal composting temperatures range between 70-90° F/20-30° C. Decomposition will slow significantly or stop completely if the compost becomes too cold (below 55° F/13° C). If you are in an area that experiences temperatures below 55° F/13° C additional heat is required if the composting toilet will be used continually or frequently. If used for intermittent cottage application (3 - 4 weekends throughout the cold season) no additional heat is required. The toilet will function as a holding tank until the temperature warms up.

## **Moisture**

Moisture is necessary to achieve good compost. Your compost should always be damp, like your garden after you have lightly watered it. This moisture allows the bacteria to travel around in the compost so that they can speed decomposition by digesting the waste. If the compost is too dry, the bacteria cannot survive and decomposition will slow or cease. When adding moisture to the compost, you are aiming for damp compost, not saturated. Too much liquid in the compost limits the amount of oxygen that aerobic bacteria require to survive. If normal urination is not enough to maintain the correct moisture level in the compost, you may need to add additional water to the drum.

## **Carbon/Nitrogen Ratio**

Almost all organic material will compost with the proper amounts of carbon and nitrogen. In order to maintain a good balance between carbon and nitrogen, only carbon-rich materials (SUN-MAR Compost Sure Green) and nitrogen-rich human waste should be added to the composting toilet.

## What's in the box?

EXCEL	EXCEL NE	COMPACT
1-Owner's Manual 1- Warranty Card 1- Rake 4 - 2"x31" Vent pipes (PVC Central Vacuum Tubing) 1- 4" Diffusor 1- Compost Sure Green 1- Hardware Kit 1- Bowl Liner 1- Footrest	1- Owner's Manual 1- Warranty Card 1- Rake 3 - 4"x31 Vent pipes (PVC) 1- 6" Diffusor 1- Compost Sure Green 1- Hardware Kit 1- Bowl Liner 1- 1" x 8' Drain Hose 1- Footrest	1-Owner's Manual 1-Warranty Card 1-Rake 4 - 2"x31" Vent pipes (PVC) Central Vacuum Tubing) 1- 4" Diffusor 1- Compost Sure Green 1- Hardware Kit 1- Bowl Liner

### Parts and Functionality

#### *Familiarize yourself with your new toilet*

- 1) Turn the drum handle clockwise to rotate the Bio-drum™ for mixing and aeration. (The drum rotates counter-clockwise and the drum door closes). This is how you will rotate the drum during regular operation.
- 2) **Pull** the drum locker button, (located on the front of the toilet above the finishing drawer), hold it out and turn the handle counter-clockwise to simulate removal of compost from the Bio-drum™ to the finishing drawer. This is how you will remove compost during regular operation.  
**Note: Compost will not drop into the drawer automatically; the drum locker must be pulled out and held while the handle is being turned counter clockwise to remove compost. There should be no resistance on the handle when turning.**
- 3) Plug the toilet's electrical cord (Electric) into a standard three-prong electrical outlet, and feel the air movement from the vent outlet at the back of the unit to ensure the vent system is working properly.
- 4) Pull out the compost finishing drawer at the bottom front of the toilet. After the toilet has been plugged in for ten minutes, place a hand on the floor of the evaporating chamber (the area under the finishing drawer) to check it is warm to the touch, and that the heater is working properly.
- 5) The toilet must be installed so that the base is protected from weather. The rubber "u" channel at the bottom of the unit is well-sealed, but if the toilet is sitting in water, has snow melting against it, or rain pouring on it, this may eventually wear through and short out the heating element. This seal is water resistant; it is not water-proof.  
**Note: The composting toilet should be placed on a level surface, or sloping slightly toward the safety drain assembly to ensure drainage of effluent. Do not install the unit in a pit where water can accumulate around the toilet.**
- 6) Attaching and Detaching the footrest (EXCEL units)  
 The footrest attaches to the unit with the metal track above the finishing drawer opening. To attach the footrest, incline the footrest at a 45° angle to the floor as shown. Insert the round top edge of the track on the footrest into the round top edge of the metal track on the unit and then lower the footrest to the floor.  
 Note: Footrest must be correctly attached before use.
 

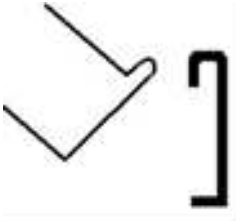

## Installation FAQ

### 1) Must I install the vent?

**Yes**, in order to ensure odorless operation.

### 2) Vent pipe leading out of the toilet

When you are installing the vent pipe, **completely avoid any downward sloping or horizontal runs**, no matter how small.

### 3) How many bends can I put in the vent pipe?

**Electric toilet: No more than four 45° bends.** There **should not** be any **horizontal** runs (no matter how small) or downward slopes of the pipe. Fasten your pipe with the supplied brackets to prevent settling.

**Non-Electric: No more than two 45° bends.** If elbows are used, a 12v fan is available for purchase from Sun-Mar and if necessary, should be installed.

### 4) Can I merge the toilet vent with an existing plumbing vent?

**No.** We realize that this will make your installation easier, but if the toilet is not installed with its own vent, it will hamper the airflow, and will lead to **odors**. In addition, other plumbing fixtures connected to the same vent will start to smell of ammonia. **The toilet needs to be installed with its own vent in order to function odorlessly.**

### 5) Where does the diffuser go?

On top of the vent stack.

### 6) I have a metal roof, an obstruction or a steeply pitched roof. Must I have the vent above the peak of the roof?

**Yes.** If the vent ends under the eave, the air from the vent may downdraft over the property, possibly causing a urine smell to occur. The vent should be installed 24-30 inches above the peak of the roof to prevent downdraft. See pages 7 and 8 for complete instruction.

### 7) How will I secure the stack if I need go to 24-30 inches above the peak of the roof?

Guy wires. These should be available at your local hardware store.

### 8) Can I use venting other than what is supplied?

**No**, always use the recommended venting. Schedule 40 venting has a smaller inside diameter that will reduce venting capacity, and may result in odor. **Flexible venting should not be used in any application**, as this will result in odor around the toilet.

### 9) Do I need to plug in my electric toilet?

**Yes.** Your composting toilet should be plugged in continuously unless it will not be used for 3 or more consecutive days.

### 10) Will I need a safety drain on the Excel, Excel NE, or Compact?

The Excel and Compact toilets are designed to evaporate all liquids when used according to their rated capacity. As a precautionary measure Sun-Mar recommends that the safety drains on all toilets be connected. For Excel NE toilets the safety drain must be connected.

### 11) Do I really need a safety drain with a non-electric toilet?

**Yes.** You will have overflow liquid, even with limited usage. **If the drain is not connected, the evaporation chamber will overflow.**

### 12) What should the safety drain be connected to?

Collect and/or treat excess liquid in an approved facility such as a recycling bed, old septic system, holding tank or drain pit. All installations should conform to local regulations.

### 13) My bathroom can get below 55° F/13 °C at times. Will this affect composting?

**Yes.** If the toilet is being used continuously, you will need to install an additional heat source, or leave the heat on in the area where the toilet is located. If you are only using it three or four weekends during this time, see page 13 for further details.

# Installation

## EXCEL AND EXCEL NE ROUGH IN DIMENSIONS

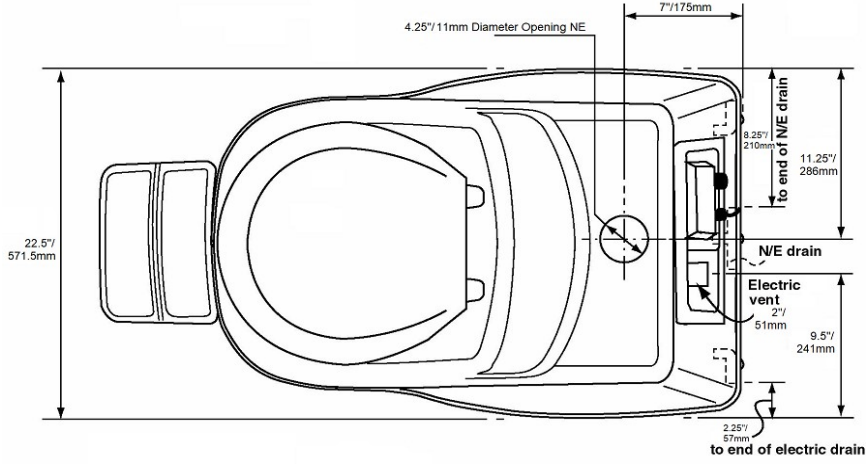
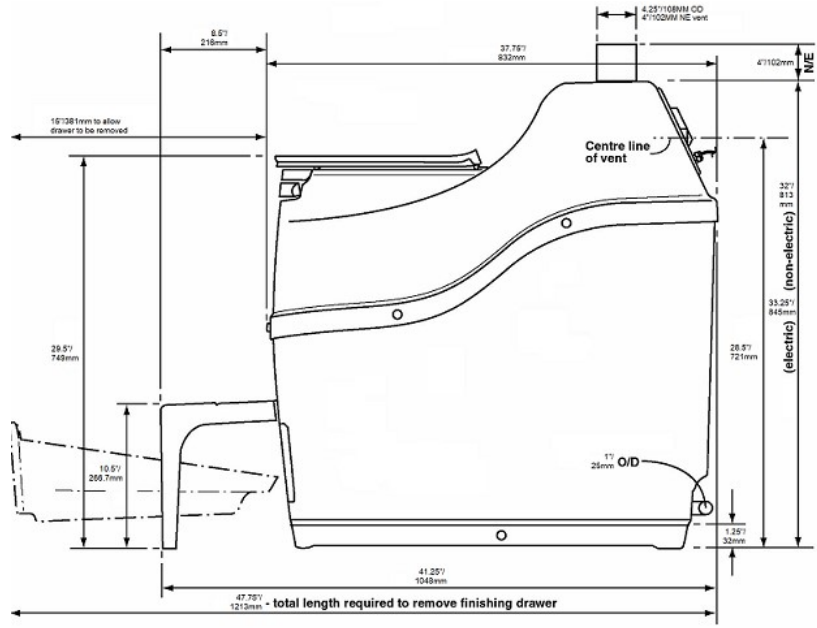

## COMPACT ROUGH IN DIMENSIONS

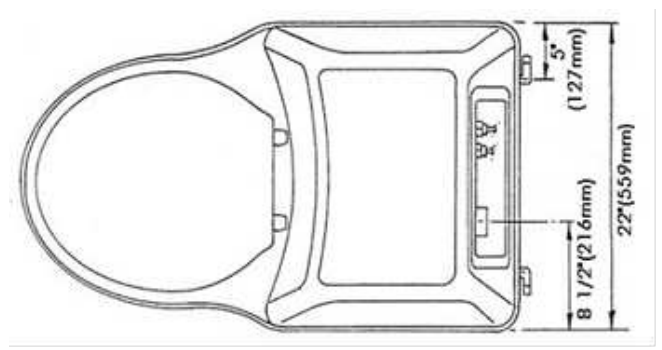
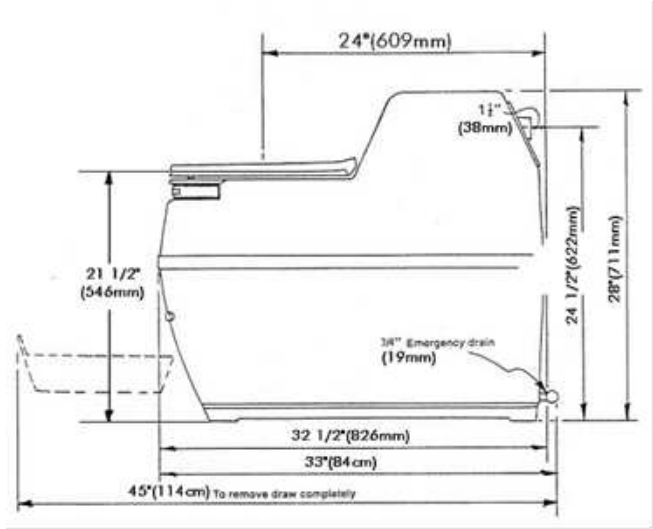



# **Installation Specifications**

## **EXCEL and COMPACT Space Required and other Installation Considerations**

- 1) Ensure that the toilet is installed on a level surface or sloping slightly towards the safety drain.
- 2) Compost will be removed from the finishing drawer. Ensure that there is at least 15" in front of the EXCEL or COMPACT toilet so that the drawer may be removed from the unit. (See page 12)
- 3) Install the toilet in a location where the safety drain hose can be connected if required. The safety drain exits from the back of the toilet and must slope downward at all points. (See page 9)
- 4) Install in a location where the vent pipe can be attached as per the instructions. (See page 7)
- 5) To ensure proper ventilation, install in a location that is not air tight. The toilet must be vented to ensure odorless operation.
- 6) The fan will run continuously 24 hours per day while in use. A ground fault interrupter (GFI) circuit is recommended for any toilet installed. If you are in an area where you experience power fluctuations, you may wish to use a surge protector.

The 230V models have an over current protection device on the heating element circuit, which is intended to protect the fuse and is located on the electric box.

## **EXCEL NE (Non-Electric) Space Required and other Installation Considerations**

- 1) Ensure that the unit is installed on a level surface or sloping slightly towards the safety drain.
- 2) Compost will be removed from the finishing drawer. Ensure that there is at least 15" in front of the EXCEL NE toilet so that the drawer may be removed from the unit. (Page 12)
- 3) Bends in the vent, downward or horizontal runs, installation near hills, or overhanging trees may cause downdraft. A 12V fan may be required.
- 4) Competing appliances (ie. wood stove) may need an air intake installed from the outdoors. The EXCEL NE has a passive vent. Competing appliances draw a lot of air and may cause your composting toilet vent to draw air into the building rather than venting to the outside. A 12V fan may be required.
- 5) The safety drain is required in all installations of the EXCEL NE. Install the unit in a location where the safety drain can be connected. The safety drain exits from the back of the unit and must slope downward at all points. (See page 9)
- 6) Install in a location where the vent pipe can be attached as per the instructions (See page 8)
- 7) To ensure proper ventilation, install in a location that is not air tight. The toilet must be vented to ensure odorless operation.

## Vent Pipe Installation – EXCEL and COMPACT

If running a vent through a wall, it should only be done at a 45° angle to prevent condensation from accumulating in the pipe, causing a constriction. Venting should only be installed **vertically**. Limit bends in the vent stack to no more than **four** that have a combined total of **180°**. Use silicone caulking to seal the connection between the vent and the toilet, all other connections may be sealed with PVC cement. **DO NOT INSTALL WITH HORIZONTAL, FLAT OR DOWNWARD SECTIONS OF VENT, NO MATTER HOW SMALL.**

A 4" diffuser is included with the EXCEL and COMPACT. This is meant to be installed at the top of the vent stack to encourage updraft. (See page 8 for installation instructions)

**INSTALL VENT SO THAT IT TERMINATES 24" - 30" ABOVE HIGHEST PEAK OF THE ROOF.** If there is more than 30" of vent, including diffuser, needed above the roof line, use guy wires to secure the vent above the roof.

All vent pipe that is exposed to the outside or in a non-heated space should be insulated if using the toilet during cold weather.

The vent must be installed separately from **ALL** other household vents. **Venting cannot be merged with other, pre-existing venting.** Doing so will prevent the toilet from operating odorlessly.

All connections in the vent pipe should be sealed. Use silicone caulking to seal the connection between the vent and the toilet. A sealant such as PVC cement may be used for all other vent connections.

The vent stack should end approximately 24" - 30" above the peak of the roof to allow for proper ventilation of odor, and to encourage updraft. Where the pipe is taken through the roof, a roof flashing may be required. If you have a steeply pitched roof, or are in an area where snow shear is a danger, you may wish to install a heavier pipe around the vent pipe where it exits from the roof. If you do choose to install in such a manner, ensure that the area between the pipes is sealed with a waterproof substance to prevent leaks.

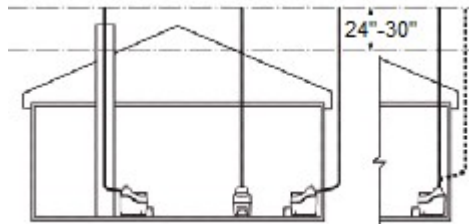
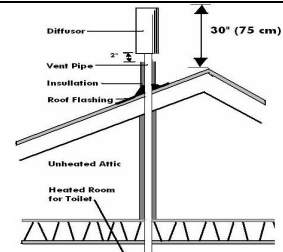

*Possible venting configurations for the 2" electric vent pipe.*

When it is necessary to lead the vent through a wall, connect one 45° elbow on the vent outlet on the unit. Using a 2" hole saw or other appropriate tool, cut a hole through the wall board behind the unit so that the vent pipe can be inserted into the 45° elbow. Cut a similar hole on the other side of the wall that is slightly higher than the inner hole so that the vent pipe will be angled upward at 45°. If installing through an exterior wall, waterproof sealant will be required around the vent pipe where it emerges from the building.

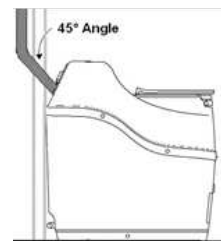

## Vent Pipe Installation – EXCEL NE

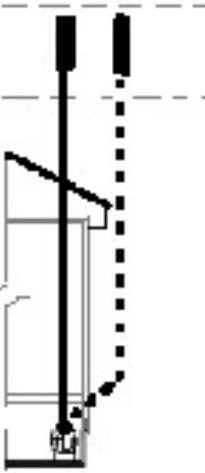
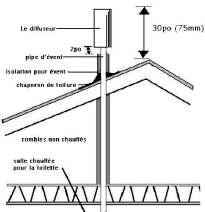
<p><b>INLET COUPLING:</b> Place the vent inlet coupling into the hole behind the toilet seat, so that the 1" of smaller diameter pipe is inserted into the hole on the top of the toilet. This is the first piece of the venting. Once you have finished assembling the vent, you should seal using silicone caulking where the inlet coupling meets the top of the toilet to prevent odor from escaping.</p>	
<p>The EXCEL NE does not have a built-in fan and operates with passive venting. Due to this, bends in the vent stack must be limited to no more than two 45° bends. All additional vent pipes should only be vertically installed. <b>THERE CAN BE NO HORIZONTAL, FLAT OR DOWNWARD SECTIONS OF VENT, NO MATTER HOW SMALL.</b></p> <p>*An optional 12volt fan may be necessary if there are competing appliances, or due to climactic conditions. This fan is available for purchase from Sun-Mar.</p>	
<p><b>INSTALL VENT SO THAT IT TERMINATES 24" - 30" ABOVE HIGHEST PEAK OF THE ROOF.</b> If there is more than 30" of vent, including diffuser, needed above the roof line, use guy wires to secure the vent above the roof.</p>	
<p>The vent must be installed separately from <b>ALL</b> other household vents. Venting cannot be merged with pre-existing venting. Doing so will prevent the toilet from operating odorlessly.</p>	
<p>All connections in the vent pipe should be sealed. Use silicone caulking to seal the connection between the vent and the toilet. A sealant such as PVC cement may be used for all other vent connections.</p>	
<p>The vent stack should end approximately 24" - 30" above the peak of the roof to allow for proper ventilation of odor, and to encourage updraft. Where the pipe is taken through the roof, a roof flashing may be required. If you have a steeply pitched roof, or are in an area where snow shear is a danger, you may wish to install a heavier pipe around the vent pipe where it exits from the roof. If you do choose to install in such a manner, ensure that the area between the pipes is sealed with a waterproof substance to prevent leaks.</p>	

## Diffusor Installation

The diffusor provided with the toilet is a simple device to be installed at the top of the vent stack with the larger pipe protruding above the smaller. To install, simply glue the diffusor vertically on the topmost section of vent pipe. The diffusor design encourages updraft, and discourages wind and weather from going down the vent stack. We do not recommend installing anything else on the top of the vent as it could impede the venting. Unlike wind turbines, diffusors are less likely to freeze in winter, and are more effective in calm weather.

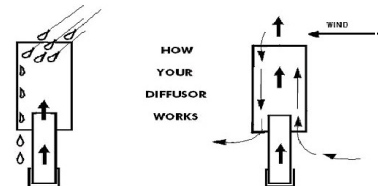

# The Safety Drain Hose

For EXCEL NE units, the safety drain hose must be connected. The safety drain is to remove excess liquid that is not evaporated from the evaporation chamber.

## Connecting The Safety Drain Hose

*\*The safety drain is gravity fed, and so, must slope downward at all points. Do not merge sinks, bathtub, or any other drains to the safety drain.*

1) **EXCEL NE:** The safety drain assembly (Fig. 1), has a cap on one end, and the other end will be uncapped to facilitate the connection of the drain hose (Included with NE unit). The cap can be removed, and placed on either side of the safety drain assembly as applicable, for convenience of installation.

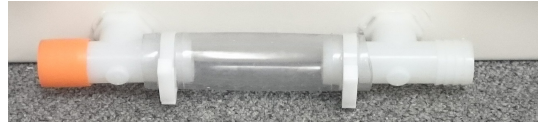

Fig 1.

**EXCEL OR COMPACT:** The safety drain assembly (Fig 2) is supplied plugged on both sides. These toilets are designed to evaporate all liquids when used according to their rated capacity. As a precautionary measure, Sun-Mar recommends that the safety drains on all toilets be connected. The drain hose is not supplied with these toilets. If connection is required, a good quality hose of appropriate length and 1" SS hose clamp should be obtained from a local building center or DIY store. The inside diameter of the drain hose for the EXCEL is 1" and for the COMPACT is 3/4".



Fig. 2.

2) Remove one drain cap, or place the cap on end of the safety drain assembly that will NOT have the drain hose connected (NE).



Fig. 3

3) Place the 1" SS hose clamp over the end of the hose that will be connected to the safety drain assembly. Carefully push the drain hose over the barbed end of the drain assembly where the cap has been removed (Fig 3) so that the drain hose will overlap the drain assembly by 1". Tip: heating the hose where it will be connected to the safety drain will help facilitate the connection.

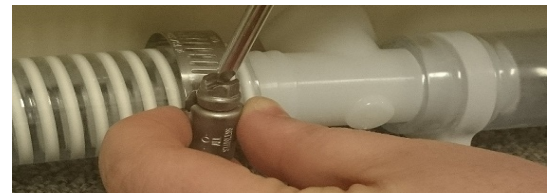

Fig 4.

4) Move the 1" SS hose clamp on to the section of the hose that is covering the end of the drain assembly. Use a flat head screwdriver to tighten the 1" SS hose clamp (Fig 4), until the drain hose is firmly affixed to the safety drain assembly.

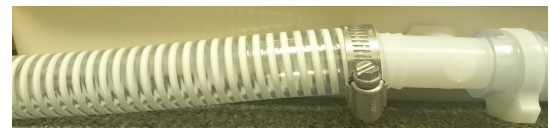
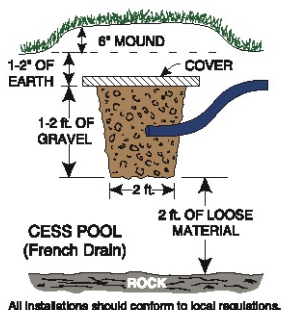

Fig 5

5) The safety drain assembly is gravity fed, ensure that the drain hose is lower than the drain assembly at all points (Fig 5). This may necessitate clamping the drain to the floor in some installations.



## Effluent Handling



The following are possible options to take care of the liquid:

- Feed into a lined pit filled with gravel and sand. Such a recycling bed also ensures a closed loop system.
- Feed into a small cesspit or "French drain".
- Plumb into an existing septic or holding tank line.

Installation should be in accordance with applicable local regulations.

## Initial Start-Up

Follow these steps when starting up your toilet for the first time, or if you have emptied the Bio-drum™ and need to re-start the compost.

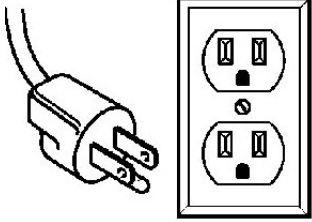
<p><b>Step 1:</b>          Spray Compost Quick: Remove the finishing drawer and spray the whole inner floor of the toilet (evaporation chamber) under the finishing drawer. This will help to prevent organic material from hardening on the floor of the toilet. Spray Compost Quick into the patented Bio-drum™ and the inside of the finishing drawer.</p>	
<p><b>Step 2:</b>          Pour 1/2 bag of Compost Sure Green (EXCEL &amp; EXCEL NE) or 1/3 bag of Compost Sure Green (COMPACT) into a bucket and add 2 quarts of warm water. Add 1/2 of the Microbe Mix packet (2 Tablespoons) to the bucket. Allow the Compost Sure Green to absorb the water (about an hour).</p>	
<p><b>Step 3:</b>          Scoop the Compost Sure Green mixture into the patented Bio-drum™ through the hole under the toilet seat on the toilet. Rotate the drum to mix. Ensure that the opening in the drum remains open under the toilet seat. The toilet is now ready for use.</p>	
<p><b>Step 4:</b>  <b>For electric toilets only:</b> The fan should run continuously 24 hours per day when installed in a primary residence.  <b>115 Volt Use:</b> Plug in to a three-pronged electrical outlet.  <b>230 Volt Use:</b> The toilet must use a main plug with an earth connection.          Replacement of electrical components (including the power cord and main plug) must be performed by a qualified person to avoid electrical hazard.</p>	

Once installation and initial startup has been completed, the toilet may be used immediately. Please note that when first used it will take approximately **6 weeks** at optimum temperatures (70-90° F/20-30° C) before you will have sufficient microbial cultures in the drum to achieve good compost. During this time, the contents of the Bio-drum™ start out as Compost Sure Green and waste. Over the first 6 weeks, you will notice that the compost will hold moisture and will become more uniformly dark in color.

During the first 6 weeks, you may notice that some Compost Sure Green has fallen through the drum screen onto the evaporation chamber to the left of the finishing drawer. This should be raked out and removed with the rake tool provided with the toilet. **NOTE: Regular toilet paper may be used. Toilet paper is a good source of carbon for your compost.**

# Ongoing Toilet Maintenance

Once your toilet is installed and you have gone through the initial start-up procedure, follow the steps outlined below to keep your toilet working optimally.





<p><b>Daily</b></p>	<p>Even if you only use the toilet for urination, <b>at least one cup</b> of Compost Sure Green should be added per person per day of use. Add the Compost Sure Green through the hole under the toilet seat.</p> <div style="text-align: center;">  </div> <p><b>When in use, the opening in the Bio-drum™ must be centered under the toilet seat, ready to receive waste at all times.</b></p>
<p><b>Every second day</b></p>	<p>Every second day before turning the handle, spray 3-4 sprays of Compost Quick on the surface of the compost. Compost Quick is an enzyme that will speed up the composting process.</p> <p>Turn the handle in a clockwise direction to mix and aerate the compost. When mixing, ensure that the drum rotates 6 complete revolutions (42 turns of the handle).</p>
<p><b>Every two weeks</b></p>	<p>Add one scoop (tablespoon) of Microbe Mix to the Bio-drum™ to 'recharge' the compost. This will help to ensure your microbe colony stays constant and healthy.</p>
<p><b>Every three months</b></p>	<p><b>Rake the evaporation chamber:</b> Remove the finishing drawer. Rake any solid debris from the inside floor of the toilet under the drawer (evaporation chamber), paying extra attention to the two back corners of the toilet as this is where debris may accumulate. Remove and dispose of the solid debris.</p>
<p><b>Twice per year</b></p>	<p><b>Clean the drum screen.</b> Spray the Bio-drum™ screen with Compost Quick and let sit for 15 minutes (this will help to loosen the debris if the screen is not too encrusted). Scrub the screen vigorously with a wire brush. If brushing the screen does not clear it and liquid is still not draining through the screen, you may have to use a screwdriver or nail to clear the holes in the drum screen. (See page 17), "<b>Liquid in Drawer</b>" for details.</p>
<p><b>Periodic maintenance</b></p>	<p><b>Remove compost from the Bio-drum™.</b> When the Bio-drum™ is half full (level with the middle of the drum hub at the front of the Bio-drum™) it is time to remove compost. To remove compost from the Bio-drum™, see the section of manual titled, "Removing Compost from the patented Bio-drum™." (See page 12)</p>

## CAUTION

- 1) **Do NOT** add chemicals, plastics, glass, metals, diapers or feminine hygiene products to the compost.
- 2) **Do NOT** add plastic, glass, metal, cleaning fluids, cigarettes. Add only waste and Compost Sure bulking material.
- 3) Kitchen or garden waste, are **NOT** recommended.
- 4) **Do NOT** add baby wipes, diapers or feminine paper as they will not compost.

# Removing Compost from the Patented Bio-drum™

The level of compost in the Bio-drum™ should never be more than half full. When the Bio-drum™ is half full (level with the middle of the drum hub at the front of the Bio-drum™) it is time to remove compost. Compost may be removed from the drum by following the steps outlined in this section.

<p><b>Pull the drum lock button</b></p>	<p>The drum locker button is located on the front of the toilet above the finishing drawer. Pull the button out approximately 1/2" and hold.</p> <p><b>Do NOT push the button in.</b></p>	<p>The drum locker button is attached to a bar that sits in a molded depression in the drum. When the button is pulled, the bar is pulled out of the depression, which allows the drum to turn counter-clockwise.</p>	
<p><b>Turn the handle counter-clockwise</b></p>	<p>While holding the drum lock button out, turn the handle counter-clockwise for three revolutions of the handle. Release the drum lock button and continue to turn the handle counter-clockwise until the handle hits a hard stop.</p>	<p>The drum door will stay open allowing compost to fall into the finishing drawer. Now composted material has been deposited into the finishing drawer.</p>	
<p><b>Level the compost in the drawer</b></p>	<p>Open the finishing drawer and use rake to level the compost.</p>	<p>Leveling the compost will prevent compost from soiling the patented Bio-drum™.</p>	
<p><b>Allow the compost to rest</b></p>	<p>Compost should now be allowed to rest in the finishing drawer for 3 - 4 weeks to finish the composting process.</p>	<p>This compost will be isolated from any new waste and should be left in the drawer for a minimum of 3-4 weeks or longer to finish composting.</p>	

Compost may be removed at any time that you need more space in the Bio-drum™ and will need to be removed more frequently for heavily used units or where the toilet is the primary residential toilet.

# Springtime Start Up [Seasonal Users]

## Empty Compost from Last Season

Before your first use of the toilet, extract compost from the Bio-drum™ by releasing the drum locker (located above the drawer opening), then rotate the handle counter-clockwise giving the drum one complete revolution only. Compost from the drum will drop into the finishing drawer. Empty the drawer and repeat this procedure until most of the compost is removed, leave 4-6" of compost. This will be your "starter base" for the coming season.

## Rake

Remove the finishing drawer completely and use the rake tool to rake any loose material from the floor of the unit. Pay careful attention to the back two corners of the unit (near the safety drain), to ensure that your safety drain does not get clogged.

## Add Water and Microbe Mix

Add some warm water to the remaining compost, enough to ensure that it is quite moist. Also, add some Sun-Mar Microbe Mix (two scoops) to give the compost a "kick-start" and rotate the drum several times to mix. If your composting toilet is electric, plug it in and use for another season.

# Winter Use

## No Winter Use

Add a few cups of water to the Bio-drum™ before closing the cabin/cottage for the season. Soak the compost in the drum to prevent it from drying out before Spring. Make sure to unplug the toilet if it is electric. If you have a non-electric toilet, it may be a good idea to place something over the diffuser to prevent animals (who are looking for a home at this time of year) from getting in.

## Occasional Winter Use

If the toilet will be used for 3-4 weekends throughout the winter season then it is considered occasional use. All of the same considerations as above [No Winter Use] should be taken with these toilets to winterize them. When the temperature dips below 55° F/13° C, composting activity will slow dramatically. These toilets do not need to be kept warm and will act only as a holding tank during the winter months until they warm up enough in the spring to begin composting again. During the winter, the compost will freeze into a solid mass so the drum should not be turned as it may damage the toilet. With this in mind, it is a good idea to remove enough compost before it gets too cold to make room in the drum for Winter Use.

## Heavy or Residential Winter Use

These units should be kept in a heated area and all winterization tips listed below should be followed:

- 1) Vent Pipe - electric models; all 2" vent pipe should be insulated if they are exposed to the outside or in an unheated area. If you are in an area that experiences extreme winter conditions, we recommend that heat tape should be applied to the exposed vent pipe to prevent ice blockages.
- 2) Safety Drain - all models; as a precautionary measure we recommend that the safety drain should be installed and insulated above the frost line. There will be less evaporation in the winter so this will help with any excess liquid. If possible, heat tape can be applied to the safety drain to prevent ice blockage.
- 3) Keep it warm; If the toilet is used frequently in the winter then the toilet should be kept in a warm place. Below 55° F/13° C, composting activity will slow dramatically so if it is in a place that falls below this temperature, a source of heat should be provided for the toilet so that it can keep up with constant use.



# Compost Troubleshooting

Symptom	Cause	Remedial Action	Prevention
<b>Compost Too Wet</b>	Compost porosity is poor	Ensure that Compost Sure Green is being used.	Use Sun-Mar Compost Sure Green
	Drum screen clogged	Spray the drum screen with Compost Quick. Scrub the drum screen with wire brush.	When toilet is in use, turn the Bio-drum™ every other day, for six (6) revolutions of the drum.
<b>Waste Not Breaking Down At All (the drum will fill up quickly)</b>  <b>AND/OR</b> <b>Large Lumps In Compost</b>	Insufficient microbes	Add Sun-Mar Microbe Mix.	Be sure to add the Microbe Mix packet at start up and a scoop every couple of weeks.
	Room temperature below 55° F/13°C	Install heat source to increase temperature. Temperature should be above 55° F/13°C constantly to ensure composting does not stop.	Install toilet in warm area. The warmer the area, the better your compost will be!
	Compost too dry/ Insufficient Moisture	Add 1/2 to 1 gallon of warm water to compost in order to bring it up to appropriate moisture level. Remove or break any lumps apart.	A moisture content of 40-60% is ideal for aerobic microbes.
<b>Drum Too Full</b>	Compost not emptied into finishing drawer in a timely fashion	Remove compost until drum is only half full or less. Rotate compost thoroughly to aerate, and add compost accelerant (Compost Quick and Microbe Mix).	Do <b>NOT</b> let drum get above 1/2 full. This will lead to a lack of aeration, and the possibility of an anaerobic compost.
<b>Strong Odor</b>	Compost anaerobic	See “ <b>Compost Too Wet</b> ”, “ <b>Drum Screen Clogged</b> ” and “ <b>Drum Too Full</b> ”	Follow “ <b>Ongoing Toilet Maintenance</b> ” and use Compost Sure Green.
<b>Flies Present</b>	Kitchen/Garden waste added	<b>Do not</b> add kitchen waste or garden scraps.	<b>Do not</b> add kitchen waste or garden scraps.
	Compost too dry  OR  Foreign material added	Applying pesticides such as pyrethrin, or any locally permitted equivalent safe for garden use, to your compost is an immediate remedy. Please contact Sun-Mar for assistance.  The alternative to using pesticides is to completely clean the toilet out, and wash the inside of the drum with soap and water.  <b>IMPORTANT:</b>  If using pesticides, avoid spilling on the outer shell of the composter.	Keep compost moist. It should have a slight gloss or shine. If it does not, add warm water to it until it reaches this consistency. Fungus gnats tend to be attracted to the fungus which forms on compost when it dries out. Moist compost will not be attractive to flies.  Do not add topsoil from the ground, composted matter, or kitchen scraps to the toilet. These may carry or attract flies.

# MECHANICAL TROUBLESHOOTING

**UNPLUG THE TOILET BEFORE ATTEMPTING ANY MAINTENANCE**

Symptom	Cause	Remedial Action	Prevention
<b>Urine Odor In Washroom</b>	Horizontal runs or downward slopes in vent pipe	Re-install the vent pipe so that there are no horizontal or low points where condensation can collect.	<b>DO NOT</b> install horizontal runs; liquid will collect and block ventilation, causing odor.
	Fan has failed	Have your serial number ready and call SUN-MAR for a replacement. Instructions are included with the replacement fan.	
	Competing appliances  OR  Downdraft	If you believe that there may be a downdraft outside of the building, it may be a good idea to remove your fan assembly prior to installation and set the fan gate to '0' to prevent urine odor in the bathroom. (This is specific to the electric models.)	
		Install a 12volt fan in vent pipe. (EXCEL NE) Wood stoves or furnaces installed in a tightly sealed room with the toilet may draw air down the vent pipe.	
<b>Occasional Urine Odor Outside</b>	<p>1) Vent stack not installed above the highest peak of the roof.</p> <p>2). If vent stack is installed above roof line, natural obstructions, such as tall trees, being located in a valley or close to a hill may be causing downdraft.</p>	<p>1) Check that the vent is installed above the highest peak of the roof. If not, extend the vent pipe. Guy wires may be necessary.</p> <p>2) Add lime to the evaporation chamber – Contact Sun-Mar for specific instructions. You will have to rake more often if you do this.</p> <p>3) SUN-MAR has a filter box available (electric units only) which will filter the ammonia out of the vented air in a downdraft situation. Call Sun-Mar for details.</p>	Follow instructions on page 7 & 8.

<b>Fan Noisy</b>	Bearings beginning to wear, OR  Dust/debris gathering on blades	1) If it is rattling, it may need to be cleaned or the bearings are worn and the fan needs to be replaced.  2) A low “hum” is the normal sound the fan will make. If you are in a very quiet setting it will be more noticeable. If this is the case, consider purchasing a fan speed control so that the fan speed may be turned down.	The fan is a continuously moving part and has a finite service life. Clean the fan with a small brush and/or compressed air nozzle once a year. This will prevent wear and lengthen the life of your fan.
<b>Fan not Working</b>	Debris in fan, or  Mechanical failure resulting in loss of power	Remove the fan assembly from the toilet and vacuum any dust out of the fan blades. Check the power source (ie. breakers, fuses). If this does not remedy the problem, have your serial number ready and call SUN-MAR	The fan is a continuously moving part which will eventually have to be changed.
<b>Liquid Build Up In Evaporation Chamber</b>	Increased usage	The amount of liquid varies substantially between installations. The safety drain needs to be installed.	As a precautionary measure install the safety drain.
	Climatic conditions	Evaporation rates vary substantially with climatic conditions. Expect faster evaporation rates during warm dry weather.	
	Mineral salts may have accumulated in the evaporation chamber, reducing evaporation rates	Fill the evaporation chamber with very hot water and 1/3 bottle of Compost Quick enzyme liquid. Leave overnight, and rake gently the following day to remove.	Rake evaporating chamber at spring startup for cottage/cabin use, and once every other month for residential use.
<b>Liquid Overflow</b>	The Safety Drain is blocked	1) Check drain line for kinks, blockages or upward bends. Remove and flush if blockages present; un-kink if bent and ensure that the drain pipe is sloping downward. If your drain pipe is in order, proceed to step 2. 2) Rake any solid materials away from the safety drain. This is the “build up” area. If drain is still clogged, proceed to step 3.	1) A clogged drain is not very likely to happen if evaporating chamber is raked every 3-4 months.  2) Use premium 1”ID (EXCEL & EXCEL NE) or ¾” ID (COMPACT) hose for the drain line. A good hose will be less likely to kink. Use elbows or fittings around bends to prevent kinks. Hose is provided with the EXCEL NE toilet.

		3) Use a wire to clear any blockage out of the safety drain assembly. A brown spot may be visible through the opaque safety drain. Drain all liquid through the safety drain by tipping the toilet back (making sure safety drain is hooked up first)	3) Use Compost Sure Green as a bulking material.
	Safety drain not connected	Connect safety drain.	
	Toilet tipped forward	Check and ensure that the toilet is level.	
<b>Heating System Not Working/ Lack Of Evaporation</b>	Test to determine whether failure has occurred	Pull finishing drawer out and put your hand in the evaporation chamber ( <b>NOT</b> in the liquid). This heat can be felt if there is liquid in the chamber. If there is no warmth rising from the floor of the toilet, your heating element is not working. It is most commonly the thermostat that has failed.  If you notice a lack of evaporation, but there is still warmth in the evaporation chamber, see “ <b>Liquid Build Up In Evaporation Chamber</b> ” for solutions.	A surge protector is recommended to protect your toilet from power surges that could cause your heating system to malfunction.
	Thermostat failure	Have your serial number ready and call SUN-MAR for a replacement. (Detailed instructions are included with the replacement part)	
	Heating element failure	Fan failure coinciding with a lack of heat, or the breaker supplying power to the heating element beginning to trip indicates a problem with the element.  Have your serial number ready and call SUN-MAR for further diagnostic instructions or to order replacement parts.	1) Install toilet with a ground fault interrupter and/or a surge protector, 2) If you remove the toilet from the bathroom for cleaning, <b>DO NOT</b> use a water hose to clean the toilet. The base is water resistant, <b>NOT</b> water proof. 3) Install according to manual guidelines.
	Blown fuse (230V toilets ONLY)	Check fuse located in the electric box to ensure that it is functioning correctly, if the wire in the fuse is charred or broken, replace the fuse. Have your serial number ready and call SUN-MAR for a replacement. (Detailed instructions are included with the replacement part)	Power surges can cause the fuse to blow. If this is a possibility in your area, a surge protector is recommended.

<b>Liquid In Finishing Drawer</b>	Drum Screen Clogged	<p>Disconnect the vent stack and remove the fan assembly. Rotate the drum until the drum screen is visible. Spray the drum screen with Compost Quick and let sit for 30-45 minutes. Use a long-handled wire brush to thoroughly scour the drum screen. Rotate drum so screen is on the bottom, then look through drawer opening to check for liquid dripping from screen.</p> <p>EXCEL NE: Remove the blank fan plate. Rotate the drum until the drum screen is visible. Spray the drum screen with Compost Quick and let sit for 30-45 minutes. Use a long-handled wire brush to thoroughly scour the drum screen. Rotate drum so screen is on the bottom, then look through drawer opening to check for liquid dripping from screen.</p>	<p>Following the ongoing maintenance described on page 11 will prevent the drum screen from becoming clogged.</p> <p>In a toilet being used residentially, the drum screen should only have to be cleaned twice a year.</p>
<b>Drum Will Not Turn</b>       <b>Drum Door Not Opening/ Closing Properly</b>	Set screw securing handle to shaft has broken.	Drill out set screw and replace, or have your serial number ready and call SUN-MAR for a handle replacement kit (instructions included).	<p>Drum should never be more than ½ full. Use the circular indent on the front inside of the drum as a guide. Compost should never be above half way up that circle. See page 12 for further information on removing compost.</p> <p><b>Do not allow the Bio-drum™ to become more than half full.</b> This can lead to excess stress on hinges and other moving parts, and can prevent compost from being able to exit the drum.</p>
	Steel roll-pin securing gear wheel to shaft has broken.	Have your serial number ready and call SUN-MAR for a replacement small gear kit.	
	Drum too full and/or  Hinges are stuck	<p>Spray hinges with Compost Quick. Scrub hinges with toothbrush or other soft nylon bristled brush.</p> <p>Remove compost using a small, hand-held tool until drum is less than half-full.</p>	

If you have any questions, please call Sun-Mar's customer service department, 1 888 341 0782 ext. 218 before proceeding with any mechanical repairs. The serial number of your composting toilet will be required for warranty purposes, and to ensure that the correct part is provided for your toilet.

# COMPACT SPECIFICATIONS

## COMPACT EXPLOSION DIAGRAM

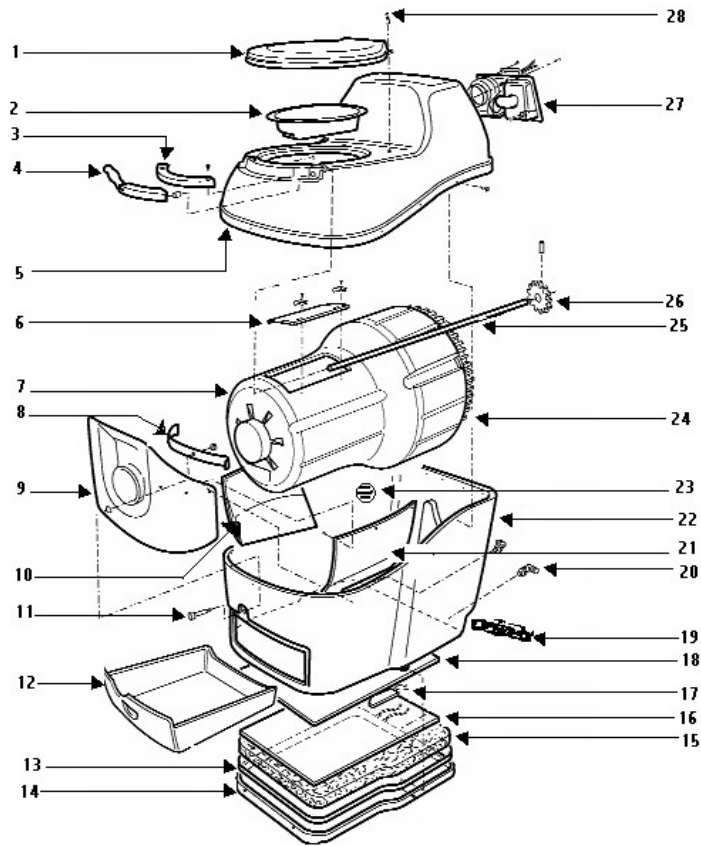

- |                               |                             |                           |
|-------------------------------|-----------------------------|---------------------------|
| 1) Toilet Seat                | 11) Drum Locker Thumb Screw | 21) Right Humus Deflector |
| 2) Bowl Liner                 | 12) Finishing Drawer        | 22) Tank                  |
| 3) Handle Cover               | 13) Rubber U Channel        | 23) Air Intake Vent       |
| 4) Swivel Handle              | 14) Heater Tray             | 24) Large Bio-drum™ Gear  |
| 5) Top                        | 15) Insulation              | 25) SS Shaft              |
| 6) Drum Door                  | 16) Heating Element         | 26) Small Gear            |
| 7) Bio-drum™                  | 17) Thermostat              | 27) Fan Assembly          |
| 8) Drum Locker                | 18) Aluminum Sheet          | 28) Seat Screw            |
| 9) Drum Bearing Plate (Front) | 19) Power Box Assembly      |                           |
| 10) Left Humus Deflector      | 20) Safety Drain Assembly   |                           |

Wiring Diagram

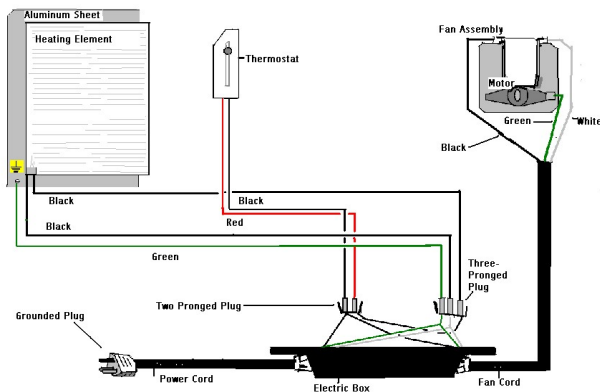

Toilet	Maximum Amps	Fan Power	Heater Power	Average Power
COMPACT (115V)	2.0 A	35 Req	200 W	125 W
COMPACT (240V)	1.0 A	35 Req	200W	125 W

# EXCEL/EXCEL NE SPECIFICATIONS

## EXCEL/EXCEL NE EXPLOSION DIAGRAM

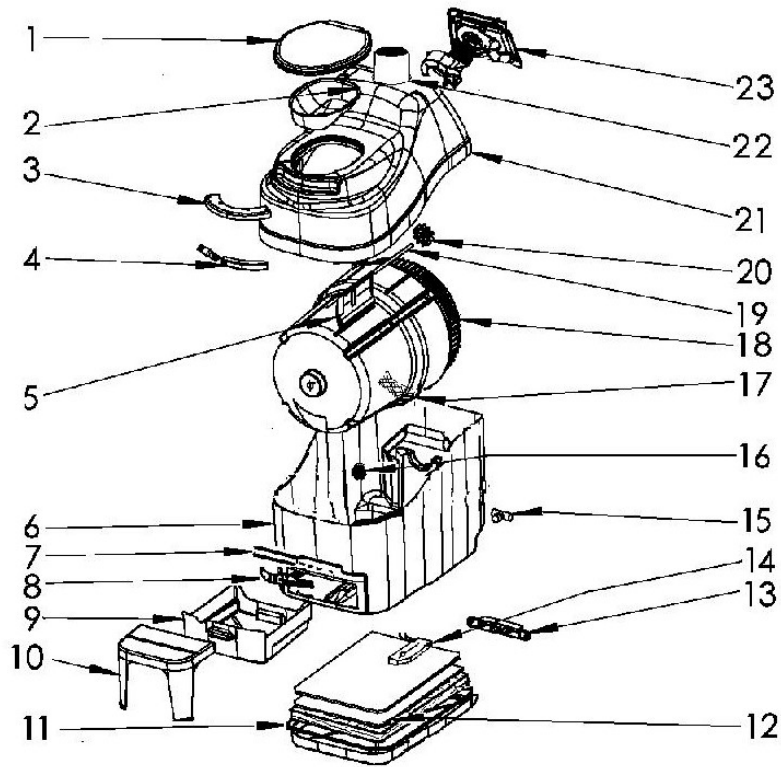



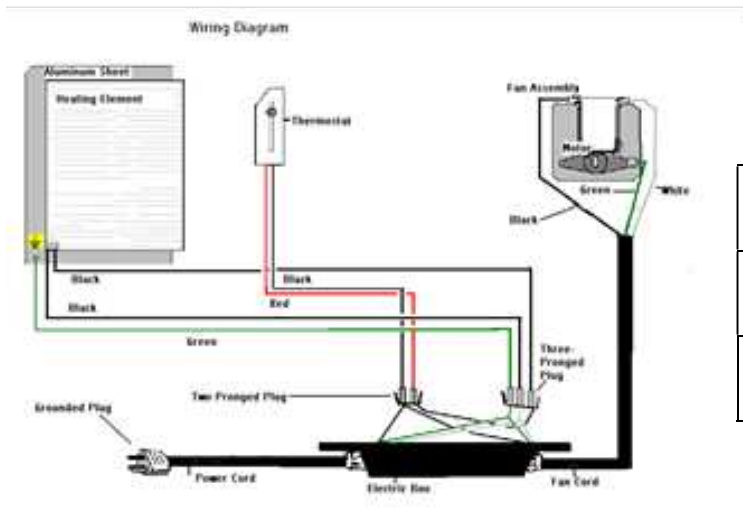



- |                     |                                    |                                |
|---------------------|------------------------------------|--------------------------------|
| 1) Toilet Seat      | 9) Finishing Drawer                | 17) Drum Screen                |
| 2) Bowl Liner       | 10) Footrest                       | 18) Bio-drum™                  |
| 3) Front Cover      | 11) Heater Tray (Electric)         | 19) Shaft Assembly             |
| 4) Handle Swivel    | 12) Heating Element (Electric)     | 20) Gear                       |
| 5) Drum Door        | 13) Electric Box (Electric)        | 21) Top                        |
| 6) Tank             | 14) Thermostat Assembly (Electric) | 22) 4" (100mm) Inlet Pipe (NE) |
| 7) Footrest Channel | 15) Safety Drain Assembly          | 23) Fan Assembly (Electric)    |
| 8) Drum Locker      | 16) Air Intake Vent                |                                |



Toilet	Maximum Amps	Fan Power	Heater Power	Average Power
EXCEL (115V)	2.4 A	35 Req	260 W	125 W
EXCEL (230V)	1.25 A	35 Req	265W	125 W

# ACCESSORY ITEMS FOR THE TOILET

SUN-MAR has developed a number of composting accessory items over the years to optimize SUN-MAR toilets.

Name	Description	
Compost Quick	Cleans and accelerates the composting action of your Sun-Mar composting toilet. Compost Quick is a specially selected natural enzyme solution that also assists in the decomposition of waste. 100% natural and non-toxic. <b>500ml(16oz) Bottle</b>	
Microbe Mix	100% natural product combining a blend of microbes and enzymes designed to start and accelerate composting in all Sun-Mar toilets. <b>500g (16oz) Jar</b>	
Compost Sure Green	The ideal bulking agent for your Sun-Mar waterless toilet. Compost Sure Green is specially formulated to keep compost enriched with organic carbon, moist and maintain porosity ensuring maximum aeration. <b>30 Litre/8 Gallon Bag</b>	
DC Vent Kit	Kit required for conversion of electric units to also operate without electricity or 12volt DC mode. Includes a 12volt DC fan. (EXCEL units only)	
AC Fan Speed Control	Designed for electric units only, the control kit allows users to adjust the speed of the fan. Ideal for installations where the toilet is used in winter applications or in bunkies where the toilet may be in close proximity to sleeping quarters. (EXCEL & COMPACT)	
12 Volt 1.4 Watt Fan	Designed for use in the 4" non-electric vent only. This fan increases the air flow in non-electric units to help overcome down draft. (EXCEL NE only)	

**Note:** Use "Compost Sure Green" for optimum results.





# WARRANTY

SUN-MAR Corp. warrants the original purchaser that this toilet is free from defects in material and workmanship under normal house or cottage use. SUN-MAR Corp. will furnish new parts for any part that fails within three years and five years on the fibreglass tank, provided that our inspection shows that such failure is due to defective material or workmanship. Any part supplied by us to replace another part is warranted for the balance of the original warranty period.

**This warranty does not cover:**

1. Damage resulting from **neglect, abuse, accident or alteration**; or damage caused by **fire, flood, acts of God or any other casualty**.
2. Parts and accessories not sold or manufactured by SUN-MAR Corp. or any damage resulting from the use of such items.
3. Damage or failure resulting from **failure of the purchaser** to follow **normal operating procedure** outlined in the Owner's Manual or in any other printed instructions.
4. **Labor and service charges** incurred in the removal and replacement of any parts found defective under the terms of this warranty.
5. **All returns to the factory must be made freight prepaid**. All shipments from the factory are made F.O.B. the factory.

This warranty is in lieu of all other warranties expressed or implied, and no person is authorized to enlarge our warranty responsibility, which is limited to the terms of this certificate. The Company reserves the right to change, improve or modify its products without obligation to install these improvements on equipment previously manufactured.

# Sun-Mar

Product Info: (905) 332-1314 - Fax: (905) 332-1315 – Customer Service: 1-888-341-0782 Ext 218  
E-mail: [compost@sun-mar.com](mailto:compost@sun-mar.com) [www.sun-mar.com](http://www.sun-mar.com)

600 Main St.  
Tonawanda, N.Y.  
14150-0888  
U.S.A.

5370 South Service Rd.  
Burlington, ON  
L7L 5L1  
CANADA

PO-MANU0-0601XX  
Jan 2020  
Rev.D24