

NOTE:
A All dimensions are in millimetres unless otherwise shown.

ONTARIO PROVINCIAL STANDARD DRAWING
LIGHT-DUTY SILT FENCE BARRIER
 Nov 2006 Rev 1
 OPSD 219.110

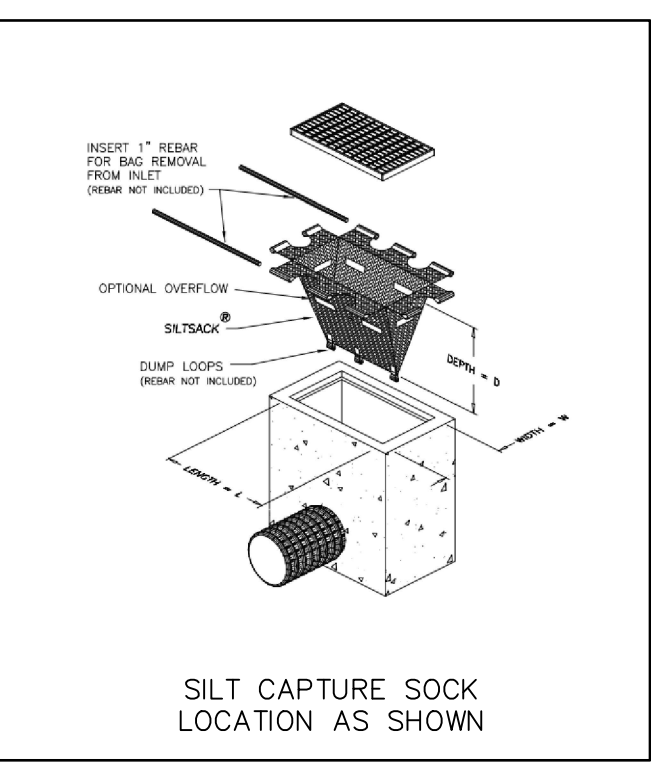

- NOTES:**
- SILT FENCE TO BE ERRECTED PRIOR TO EARTH WORKS BEING COMMENCED. SILT FENCE TO BE MAINTAINED UNTIL VEGETATION IS ESTABLISHED OR UNTIL START OF SUBSEQUENT PHASE.
 - STRAW BALE SEDIMENT TRAPS TO BE CONSTRUCTED IN EXISTING ROAD SIDE DITCHES. TRAPS TO REMAIN AND BE MAINTAINED UNTIL VEGETATION IS ESTABLISHED.
 - SILT SACK TO BE PLACED AND MAINTAINED UNDER COVER OF ALL CATCHBASINS. GEOTEXTILE SILT SACK IN STREET C/S TO REMAIN UNTIL ALL CURBS ARE CONSTRUCTED. GEOTEXTILE FABRIC IN RVCBS TO REMAIN UNTIL VEGETATION IS ESTABLISHED. ALL CATCHBASINS TO BE REGULARLY INSPECTED AND CLEANED, AS NECESSARY, UNTIL SOD AND CURBS ARE CONSTRUCTED.
 - CONTRACTOR TO PROVIDE DETAILS ON LOCATION(S) AND DESIGN OF DEWATERING TRAP(S) PRIOR TO COMMENCING WORK. CONTRACTOR ALSO RESPONSIBLE FOR MAINTAINING TRAP(S) AND ADJUSTING SIZE(S) IF DEEMED REQUIRED BY THE ENGINEER DURING CONSTRUCTION.
 - CONTRACTOR TO PROTECT EXISTING CATCHBASINS WITH FILTER CLOTH UNDER THE COVERS TO TRAP SEDIMENTATION. REFER TO IDENTIFIED STRUCTURES.

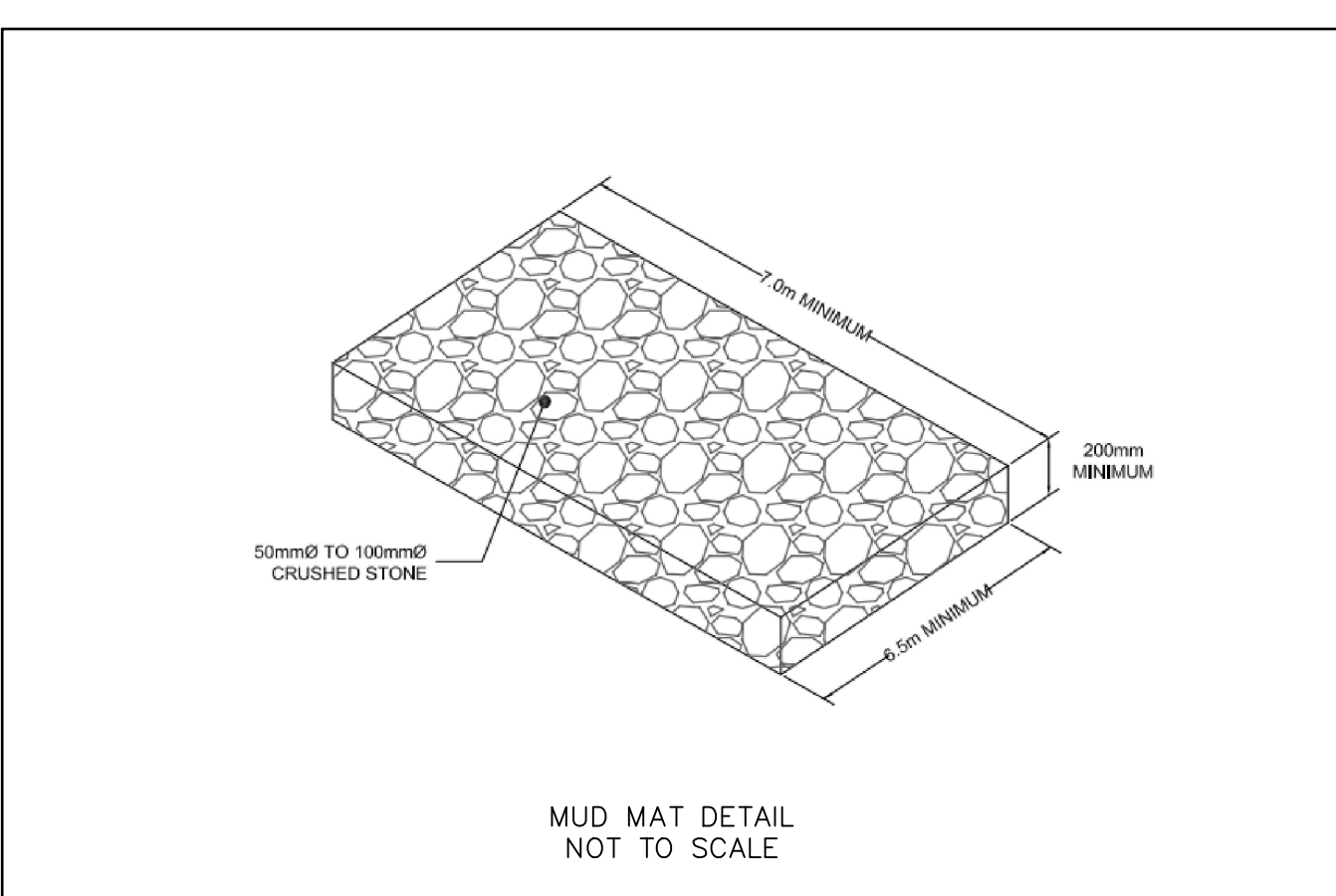
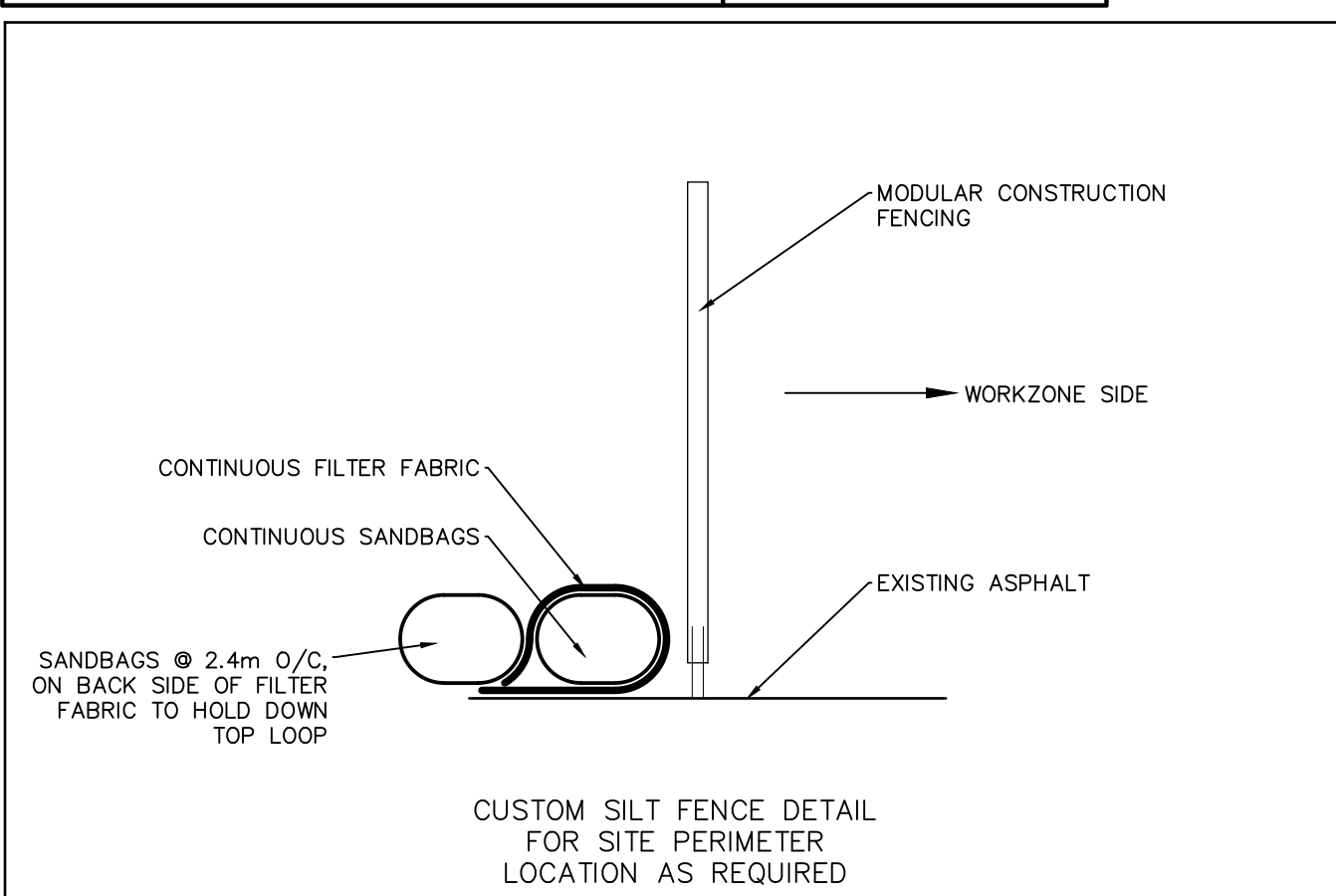
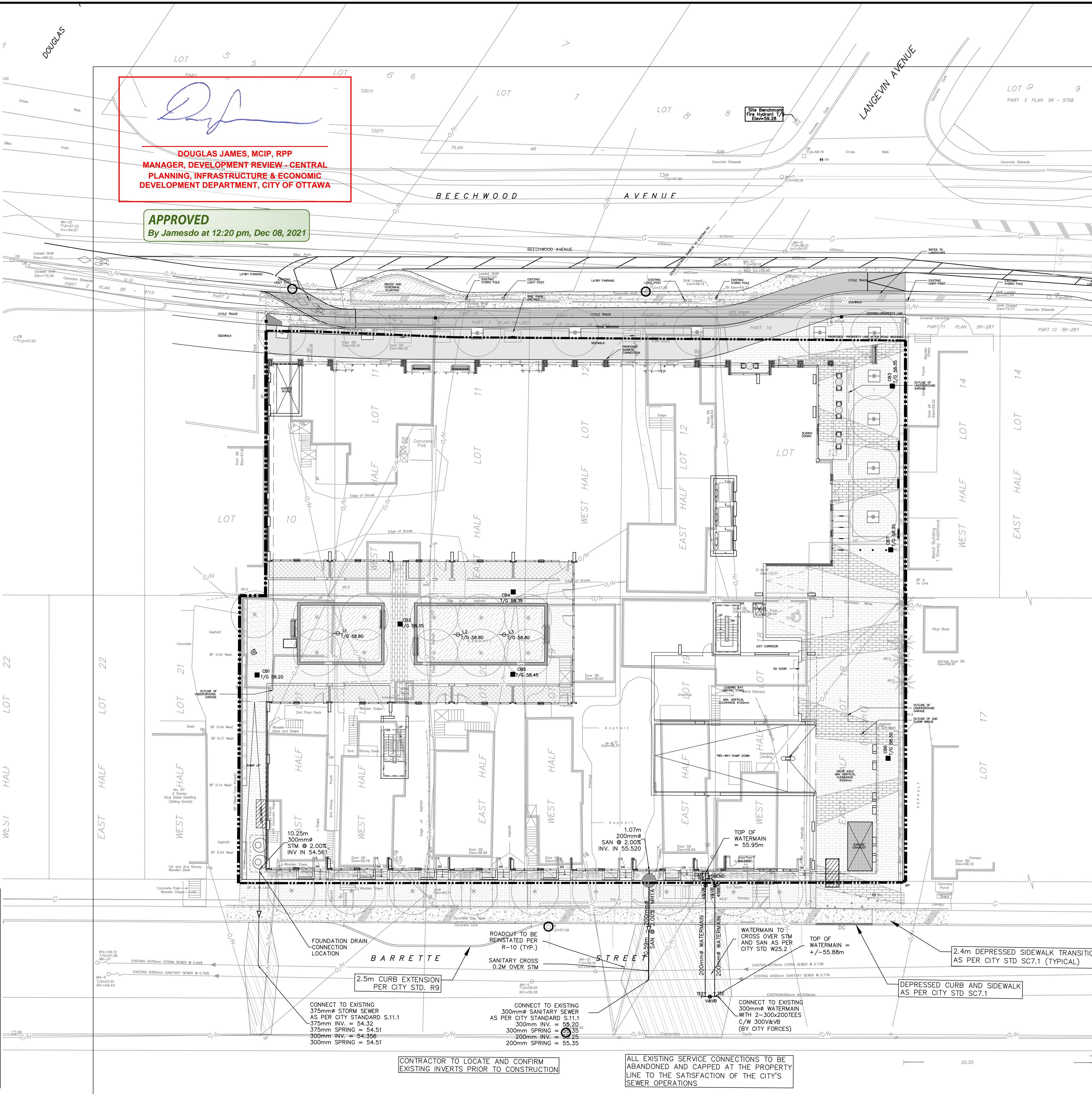

- LEGEND:**
- LIGHT DUTY SILT FENCE AS PER OPSD-219.110
 - CUSTOM SILT FENCE (SEE DETAIL)
 - STRAW BALE CHECK DAM AS PER OPSD-219.180
 - ROCK CHECK DAM AS PER OPSD-219.210
 - SILT SACK PLACED UNDER EXISTING CB COVER
 - TEMPORARY MUD MAT 0.20m THICK 50mm CLEAR STONE ON NON WOVEN FILTER CLOTH

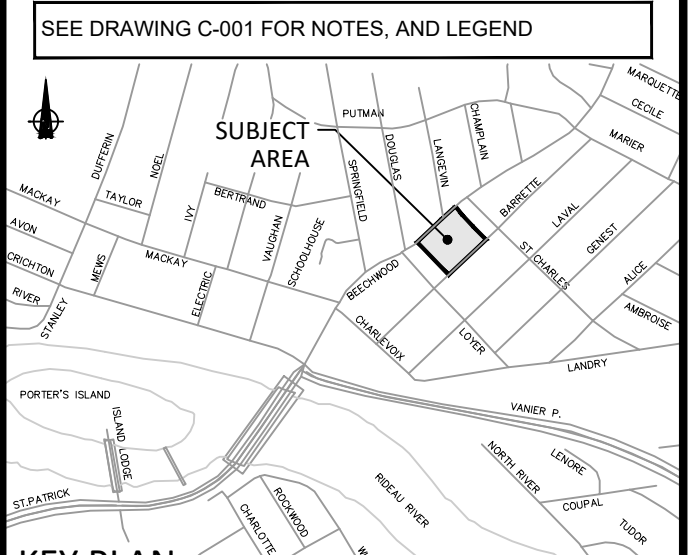

KEY PLAN
N.T.S.

No.	REVISIONS	By	Date
3	REVISED AS PER CITY COMMENTS	D.G.Y.	2021-05-07
2	2ND SUBMISSION	D.G.Y.	2020-12-18
1	ISSUED FOR SPA	D.G.Y.	2020-07-31



IBI GROUP
 400 - 333 Preston Street
 Ottawa ON K1S 5N4 Canada
 tel 613 225 1311 fax 613 225 9868
 ibigroup.com

Project Title
**78-90 BEECHWOOD/
 69-93 BARRETTE**

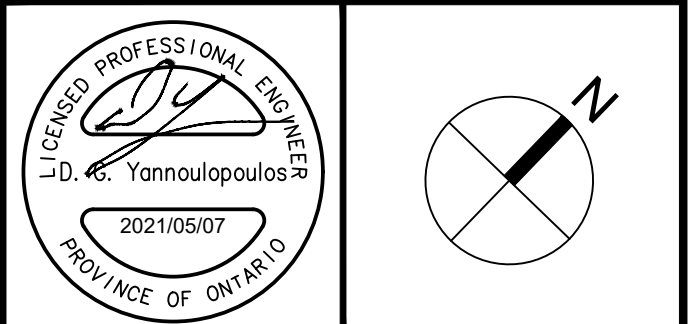

Drawing Title
**EROSION AND
 SEDIMENTATION
 CONTROL PLAN**

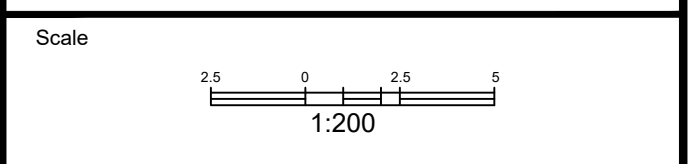

Design	Date
J.B.	AUG. 2020
Drawn	Checked
J.B./D.P.S.	D.G.Y.
Project No.	Drawing No.
125192	C-900

CITY PLAN No. 18404
 CITY FILE No. D07-12-20-0186