

- LEGEND**
- +106.00 EXISTING ELEVATION
 - x107.00 PROPOSED GRADE
 - 2.0% PROPOSED DRAINAGE SLOPE AND DIRECTION
 - x107.00 IBI GROUP DESIGN GRADE
 - PROPERTY BOUNDARY
 - CATCH BASIN
 - EXISTING CATCH BASIN
 - EXISTING HYDRANT
 - SWALE
 - H.P. HIGH POINT
 - DC DEPRESSED CURB
 - TERRACING (3H:1V MAX.)
 - RETAINING WALL
 - 100m NO-BUILD SETBACK
 - 2 YEAR PONDING LIMIT
 - 5 YEAR PONDING LIMIT
 - 100 YEAR PONDING LIMIT
 - ⊕ BOREHOLE
 - △ BUILDING ENTRANCE (REFER TO SITE PLAN)
 - GALVANIZED CHAIN LINK FENCE (REFER TO SITE PLAN)
 - GALVANIZED W-BEAM GUARDRAIL (OPSD 912.130)
 - B BOLLARD (REFER TO SITE PLAN)
 - BH POST-MOUNTED BLOCK HEATER (REFER TO SITE PLAN)
 - LIGHT STANDARD (REFER TO SITE PLAN)
 - TWSI (REFER TO SITE PLAN)
 - MAJOR OVERLAND FLOW ROUTE
 - HEAVY DUTY ASPHALT LIMITS

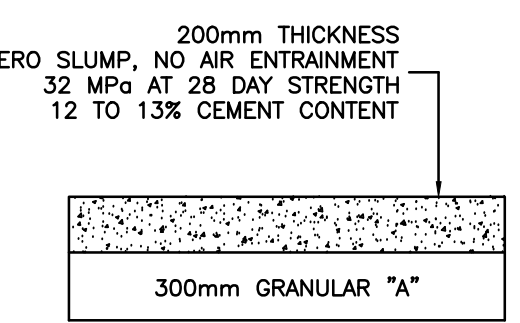

NOTE:
 1. REFER TO GEOTECHNICAL INVESTIGATION PREPARED BY PATERSON GROUP, REPORT PG5618-1, DATED APRIL 9, 2021.
 2. REFER TO LIMITS OF INSTALLATION ON SITE PLAN.

ROLLER COMPACTED CONCRETE PAVEMENT STRUCTURE DETAIL
N.T.S.

LOCATION	SURFACE STORAGE AREAS					
	2 YEAR		5 YEAR		100 YEAR	
	STORAGE VOLUME (m³)	PONDING DEPTH (m)	PONDING ELEVATION (m)	STORAGE VOLUME (m³)	PONDING DEPTH (m)	PONDING ELEVATION (m)
CB 1	39.1	0.16	106.58	78.6	0.20	106.62
CB 2	43.4	0.18	106.50	79.2	0.22	106.54
CB 3	29.9	0.17	106.39	63.4	0.21	106.43
CB 5	40.9	0.16	106.58	79.9	0.20	106.62
CB 6	40.3	0.17	106.49	65.2	0.19	106.51
CB 7	50.9	0.19	106.41	83.8	0.22	106.44

NOT FOR CONSTRUCTION

NOTES

THE POSITION OF ALL POLE LINES, CONDUITS, WATERMANS, SEWERS AND OTHER UNDERGROUND AND OVERGROUND UTILITIES AND STRUCTURES IS NOT NECESSARILY SHOWN ON THE CONTRACT DRAWINGS, AND WHERE SHOWN, THE ACCURACY OF THE POSITION OF SUCH UTILITIES AND STRUCTURES IS NOT GUARANTEED. BEFORE STARTING WORK, DETERMINE THE EXACT LOCATION OF ALL SUCH UTILITIES AND STRUCTURES AND ASSUME ALL LIABILITY FOR DAMAGE TO THEM.

NO.	REVISION DESCRIPTION	DATE	BY
5	REVISED PER COMMENTS	09/08/21	SMC
4	ISSUED FOR TENDER	11/06/21	SMC
3	REVISED PER COMMENTS	28/05/21	SMC
2	ISSUED FOR PROGRESS REVIEW	22/03/21	SMC
1	ISSUED FOR SITE PLAN APPLICATION	02/12/20	SMC

SCALE	
0	5m 10m 20m
HORIZONTAL 1:500	

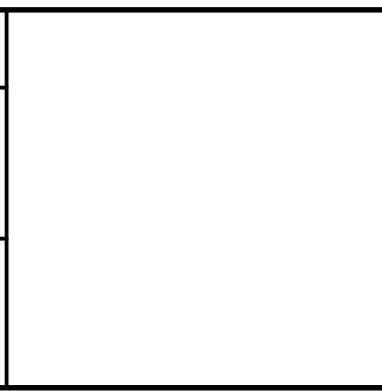

Robinson Land Development

350 Palladium Drive
Ottawa, ON K2V 1A8
(613) 592-6060 roil.com

DESIGN	BLM
CHECKED	SMC
DRAWN	BLM
CHECKED	SMC
APPROVED	SMC

MARITIME-ONTARIO FREIGHT LINES LIMITED

KANATA WEST BUSINESS PARK
8800 CAMPEAU DRIVE, OTTAWA, ON

PROJECT No.	
20027	
SURVEY	
STANTEC	
DATED	
AUGUST 2021	
DWG. No.	
20027-GR3	

PROJECT No. 20027
 SURVEY STANTEC
 DATED AUGUST 2021
 DWG. No. 20027-GR3