



Site Servicing and Stormwater Management Report  
Residential Development  
229 + 241 Beechwood Ave.  
Ottawa, ON

**Client:**

229 Beechwood Holdings Inc. and 241 Beechwood Holdings Inc.  
C/O Bintee Dev Inc.  
226 Argyle Avenue  
Ottawa, ON K2P 1B9

**Submitted for:**

Site Plan Control Application

**Project Name:**

229, 241 Beechwood Avenue

**Project Number:**

OTT-00238207-C0

**Prepared By:**

EXP  
2650 Queensview Drive  
Ottawa, ON K2B 8H8  
t: +1.613.688.1899  
f: +1.613.225.7337

**Date Submitted:**

March 22, 2022

## Site Servicing and Stormwater Management Report Residential Development 229 + 241 Beechwood Ave, Ottawa, ON

**Client:**

229 Beechwood Holdings Inc. and 241 Beechwood Holdings Inc.  
C/O Bintee Dev Inc.  
226 Argyle Avenue  
Ottawa, ON K2P 1B9

**Submitted for:**

Site Plan Control Application

**Project Name:**

229, 241 Beechwood Avenue

**Project Number:**

OTT-00238207-C0

**Prepared By:**

EXP  
2650 Queensview Drive  
Ottawa, ON K2B 8H8  
t: +1.613.688.1899  
f: +1.613.225.7337

**Prepared by:**

**Approved by:**



Jason Fitzpatrick, P.Eng.  
Project Engineer

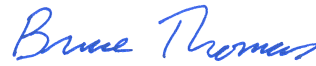

Bruce Thomas, P.Eng.  
Senior Project Manager

**Date Submitted:**

March 22, 2022

# Table of Contents

- 1 Introduction ..... 1
  - 1.1 Overview ..... 1
- 2 Existing Conditions..... 2
- 3 Existing Infrastructure..... 3
- 4 Pre-Consultation / Permits / Approvals..... 3
- 5 Water Servicing..... 4
  - 5.1 Existing Water Servicing..... 4
  - 5.2 Water Servicing Proposal ..... 4
  - 5.3 Water Servicing Design ..... 5
  - 5.4 Water Servicing Design Criteria ..... 5
  - 5.5 Estimated Water Demands ..... 6
  - 5.6 Boundary Conditions..... 7
  - 5.7 Fire Flow Requirements ..... 7
  - 5.8 Review of Hydrant Spacing ..... 8
- 6 Sewage Servicing ..... 10
  - 6.1 Existing Sewage Conditions..... 10
  - 6.2 Proposed Sewage Conditions..... 10
- 7 Storm Servicing & Stormwater Management..... 11
  - 7.1 Minor System Design Criteria ..... 11
  - 7.2 Major System Design Criteria..... 12
  - 7.3 Runoff Coefficients..... 12
  - 7.4 Pre-Development Conditions..... 12
  - 7.5 Allowable Release Rate ..... 13
  - 7.6 Proposed Stormwater System ..... 13
  - 7.7 Flow Attenuation & Storage..... 15
  - 7.8 Quality Control ..... 15
- 8 Erosion & Sediment Control ..... 16
- 9 Conclusions and Recommendations..... 17
- 10 Legal Notification..... 18



## List of Figures

Figure 2-1 - Site Location .....	2
Figure 5-1 – Watermains Near Proposed Site .....	4
Figure 5-2 – Review of Hydrant Spacing .....	9
Figure 7-1 – Post-Development Storm Drainage .....	14

## List of Tables

Table 5-1 - Summary of Water Supply Design Criteria .....	6
Table 5-2 : Water Demand Summary .....	7
Table 5-3 - Summary of Design Parameters Used in Calculating Required Fire Flows (RFF) Using FUS.....	8
Table 5-4 –Fire Flows Based on Hydrant Spacing .....	9
Table 6-1 – Summary of Wastewater Design Criteria / Parameters.....	10
Table 6-2 – Summary of Anticipated Sewage Rates .....	11
Table 7-1 – Summary of Runoff Coefficients .....	12
Table 7-2 – Summary of Pre-Development Flows .....	12
Table A-1 – Water Demand Chart.....	A
Table A-2 – Summary of Required Fire Flows (RFFs) .....	A
Table A-3 – Fire Flow Requirements Based on Fire Underwriters Survey (FUS) – 229 Beechwood .....	A
Table A-4 – Fire Flow Requirements Based on Fire Underwriters Survey (FUS) – 241 Beechwood .....	A
Table A-5 – Estimated Water Pressures at 229 Beechwood Ave .....	A
Table A-6 – Estimated Water Pressures at 241 Beechwood Ave .....	A
Table A-7 – Available Fire Flows Based on Hydrant Spacing .....	A
Table A-8 – NOT USED .....	A
Table A-9 – Sanitary Sewer Design Sheet .....	A
Table A-10 – Average Runoff Coefficients for Pre-Development Conditions.....	A
Table A-11 – Peak Runoff for Pre-Development Conditions .....	A
Table A-12 – Allowable Peak Flows (Based on Max C=0.50 with Tc=10mins & 2-yr Storm) .....	A
Table A-13 – Average Runoff Coefficients for Post-Development .....	A
Table A-14 – Summary of Post-Development Peak Flows (Uncontrolled and Controlled).....	A
Table A-15 – Summary of Post Development Storage and Release Rates .....	A
Table A-16 – Calculation of Available Surface Storage .....	A
Table A-17 – Calculation of Underground Pipe Storage .....	A
Table A-18 – Calculation of Underground Structure Storage .....	A
Table A-19 – Storage Volumes For 2-Year, 5-Year, and 100-Year Storms (229 Beechwood).....	A
Table A-20 – Storage Volumes For 2-Year, 5-Year, and 100-Year Storms (241 Beechwood).....	A
Table A-21 – 5-Year and 100-Year Roof Design Sheet (229 Beechwood).....	A
Table A-22 – 5-Year and 100-Year Roof Design Sheet (241 Beechwood).....	A

## List of Appendices

Appendix A – Design Tables.....	A
Appendix B – Consultation / Correspondence.....	B
Appendix C – Background Information.....	C
Appendix D – Drawings.....	D

# 1 Introduction

## 1.1 Overview

EXP Services Inc. (EXP) was retained by 229 Beechwood Holdings Inc. and 241 Beechwood Holdings Inc. to prepare a Site Servicing and Stormwater Management Report for the proposed redevelopment of 229 and 241 Beechwood Ave. in support of a Site Plan Control Application.

The two lots have a combined area of 0.2105 hectares and both lots are 0.1064 hectares and 0.1041 hectares for 229 and 241 Beechwood respectively. The site is situated along Beechwood Avenue between Green Avenue and Corona Avenue, as illustrated in **Figure 2-1** below. The lots are within the City of Ottawa urban boundary and situated in Rideau-Rockcliffe (Ward 13). The description of the subject property is noted below:

229, 231 Beechwood Avenue:

- Lot 10, PIN 04226-0120
- Part 2 Plan 4R-5284, PIN 04226-0121
- Lot 11, PIN 04226-0120
- Lot 12, PIN 04226-0122
- Part 1 Plan 4R-5284, PIN 04226-0123

241, 245, 247 Beechwood Avenue:

- Lot 24, PIN 04226-0136
- Part 3 Plan 4R-1168, PIN 04226-0166
- Lot 25, PIN 04226-0137
- Part 4 Plan 4R-1168, PIN 04226-0167
- Lot 26, PIN 04226-0138
- Part 5 Plan 4R-1168, PIN 04226-0168

The proposed development will consist of two (2) new residential buildings – 229 Beechwood and 241 Beechwood. 229 Beechwood will be a 3-storey residential apartment building having 42 units with a basement parking lot. 241 Beechwood will be four 4-storey residential building with 52 units with a basement level parking. There will be three (3) standard parking spots and one (1) handicap parking spot in each building.

This report will discuss the adequacy of the adjacent municipal watermain, sanitary sewers and storm sewers to provide the required water supply, convey the sewage and stormwater flows that will result from the proposed development.

## 2 Existing Conditions

Within the site, there are five (5) existing buildings. The current zoning of the property is R4 - Residential Fourth Density Zone and includes residential dwellings. The following summarizes the current building uses within the property.

- Existing Building 1 (Lot 26) 2 Storey vinyl sided dwelling.
- Existing Building 2 (Lot 25) 2 Storey stucco and metal sided dwelling.
- Existing Building 3 (Lot 24) 2 Storey stucco and metal sided dwelling.
- Existing Building 4 (Lot 12) 3 Storey brick dwelling.
- Existing Building 5 (Lot 11) 2 Storey metal sided dwelling.

The topography of the subject site is sloped from the rear (west) towards the front (east) at approximately 10% grade. A local site access road, Carsdale Avenue, bisects the proposed development from north to south between existing lot 12 and existing lot 24.

There is one (1) vehicular access point into each building from Beechwood Avenue.

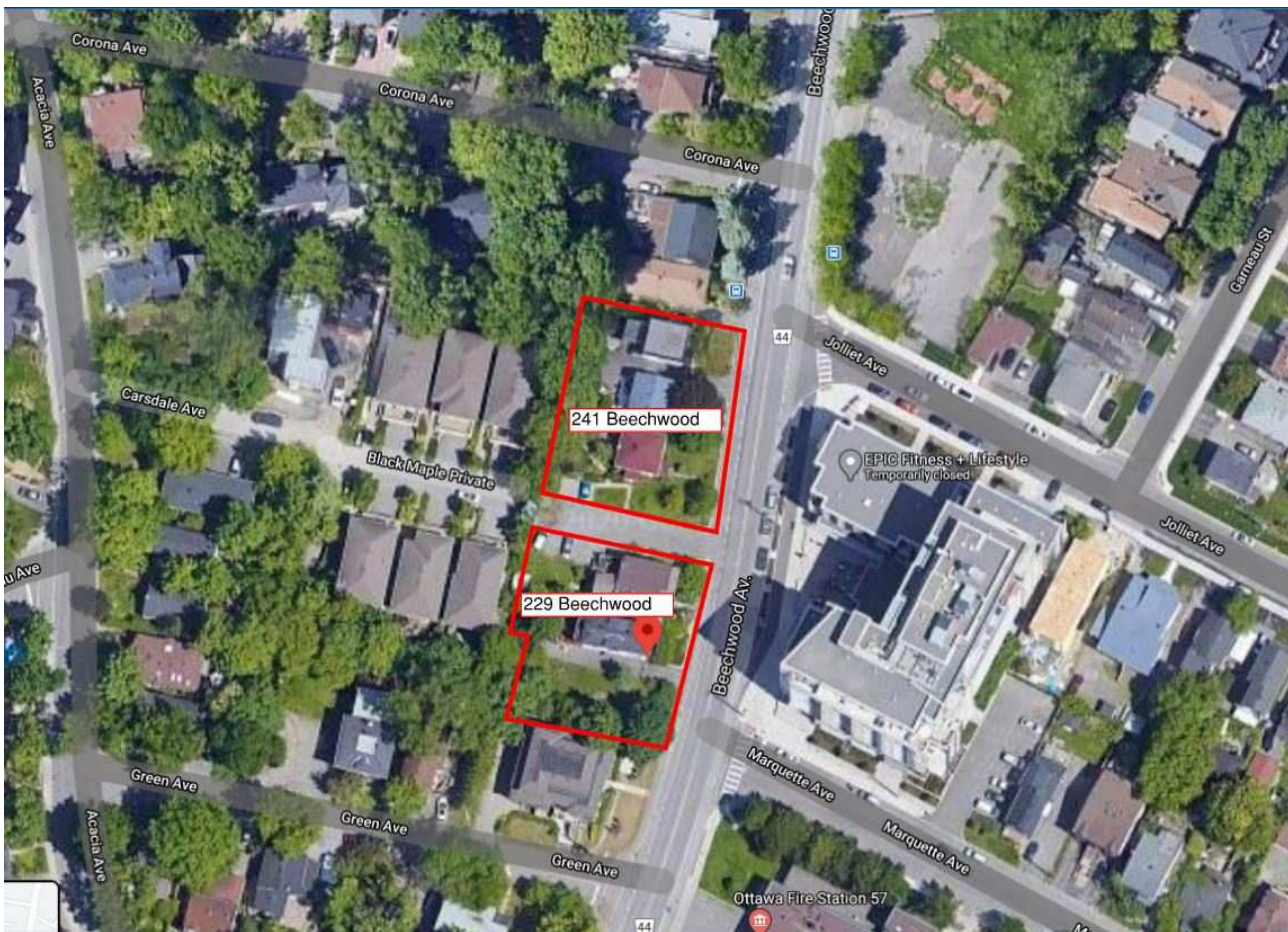

Figure 2-1 - Site Location

### 3 Existing Infrastructure

The proposed project includes five (5) buildings that will be removed during the redevelopment of the two sites. From review of the sewer and watermain mapping, as-built drawings and Utility Central Registry (UCC) plans, the following summarizes the onsite and adjacent offsite infrastructure:

#### On Beechwood Avenue

300mm dia. concrete sanitary sewer running from north to south along Beechwood Avenue.

1200mm dia. concrete reinforced storm sewer running from north to south along Beechwood Avenue.

254mm dia. unlined cast iron watermain along Beechwood Avenue.

Each lot is assumed to have private sanitary and watermain service connections.

### 4 Pre-Consultation / Permits / Approvals

A pre-consultation meeting was held with the City prior to design commencement. This teleconference meeting, held May 5, 2020, outlined the submission requirements and provided information to assist with the development proposal.

The proposed site is located within the Rockcliffe Park Heritage District and will require approvals under the Ontario Heritage Act. The site will also require an application for Site Plan Control (complex) and potential variances. This site is located in a design priority area and will therefore be subject to UDRP consultation and review.

Generally, an Environmental Compliance Approval (ECA) would be obtained from the Ministry of Environment, Conservation and Parks (MECP), formerly the Ministry of the Environment and Climate Change (MOECC), for any onsite private Sewage Works. The onsite Sewage Works would generally include the onsite stormwater works such as flow controls, associated stormwater detention, and treatment works. However, an Approval Exemption under Ontario Regulation 525/98 can be applied. Under Section 3 of O'Reg 525/98, Section 53 (1) and (3) do not apply to the alteration, extension, replacement or a change to a stormwater management facility that 1) is designed to service one lot or parcel of land, b) discharges into a storm sewer that is not a combined sewer, c) does not service industrial land or a structure located on industrial land, and finally d) is not located on industrial land. Based on this exemption, if the stormwater management works within the site remain located within one property parcel, then an Approval Exemptions under O'Reg 525/98 would apply and therefore not necessitate an ECA.

In addition, various design guidelines were referred to in preparing the current report including:

Bulletin ISDTB-2012-4 (20 June 2012)

Technical Bulletin ISDTB-2014-01 (05 February 2014)

Technical Bulletin PIETB-2016-01 (September 6, 2016)

Technical Bulletin ISDTB-2018-01 (21 March 2018)

Technical Bulletin ISDTB-2018-04 (27 June 2018)

Ottawa Design Guidelines – Water Distribution, July 2010 (WDG001), including:

Technical Bulletin ISDTB-2014-02 (May 27, 2014)

Technical Bulletin ISTB-2018-02 (March 21, 2018)

Technical Bulletin ISTB-2021-03 (August 18, 2021)



Stormwater Management Planning and Design Manual, Ontario Ministry of the Environment and Climate Change, March 2003 (SMPDM).

Design Guidelines for Drinking-Water Systems, Ontario Ministry of the Environment and Climate Change, 2008 (GDWS).

Fire Underwriters Survey, Water Supply for Public Fire Protection (FUS), 1999.

Ontario Building Code 2012, Ministry of Municipal Affairs and Housing.

## 5 Water Servicing

### 5.1 Existing Water Servicing

The subject site is located within the City of Ottawa's water distribution system 1E pressure zone. The site is not currently serviced by any large diameter watermain connection. From GeoOttawa, it is shown that a 254mm dia. watermain runs along Beechwood Avenue towards the east of the proposed development site. It is assumed that each of the five (5) existing buildings on the site are serviced individually from this 254mm dia. watermain. Figure 5-1 below illustrates the existing watermains (in blue) in the subject site area.



Figure 5-1 – Watermains Near Proposed Site

### 5.2 Water Servicing Proposal

The proposed development will consist of two (2) multiple family residential buildings – 229 Beechwood Avenue and 241 Beechwood Avenue. 229 Beechwood Ave. is comprised of 42 residential units and 241 Beechwood Ave. is comprised of 52 residential units.

Water supply for the site will be provided by the existing 254mm dia. watermain running along Beechwood Avenue. Each building, 229 and 241 Beechwood Ave., will be serviced by their own 100mm dia. PVC watermain approximately 18m and 19m in length respectively. The Site Servicing Plan in **Appendix E** illustrates the water servicing of the property.

### 5.3 Water Servicing Design

The water servicing requirements for the proposed buildings are designed in accordance with the City Design Guidelines (July 2010). The following steps indicate the basic methodology that was used in our analysis:

Estimated water demands under average day, maximum day and peak hour conditions. As the total population estimate was less than 500, MECP Design Guidelines (Table 3-3) peaking factors were used.

Estimated the required fire flow (RFF) based on the Fire Underwriters Survey (FUS).

Obtained hydraulic boundary conditions (HGL) from the City, based on the above water demands and required fire flows.

Boundary condition data and water demands were used to estimate the pressure at the proposed building, and this was compared to the City's design criteria.

Since the average day demand for each individual building did not exceed 50 m<sup>3</sup> per day, redundant watermains are not required as per Section 4.31 of the WDG001. Please refer to **Table A-1** in **Appendix A** for detailed calculations of the total water demands.

A review of the estimated watermain pressure at each building connection, based on the boundary conditions provided, was completed. **Table A-5** & **Table A-6** in **Appendix A** illustrates the anticipated pressures at each building connection.

Based on the hydraulic grade line (HGL) provided by the City it is evident that high pressures already exist in the water distribution system at the property. Static pressures of  $\pm 70$  psi – 87 psi are typically available. Due of the relatively short distance that would be necessary between the buildings and the watermain connection, minimal pressure loss is anticipated. The pressure available at the building connection would be within  $\pm 2$  psi of the pressure in the city main based on a 100mm supply.

Under peak hour conditions the anticipated pressure at the building is within  $\pm 2$  psi of the city's distribution main pressure. Anticipated pressure losses at the top floor are approximately 19 and 22 psi for 229 and 241 Beechwood Ave respectively.

Based on the results, the installation of a 100mm watermain is proposed. Pressure reducing measures are required as operating pressures are higher than 80 psi.

### 5.4 Water Servicing Design Criteria

**Table 5-1** below summarizes the Design Criteria that was used to establish the water demands and the required fire flows, based on the proposed building uses. The design parameters that apply to this project and used for calculations are identified below.

**Table 5-1 - Summary of Water Supply Design Criteria**

Design Parameter	Value	Applies
Population Density – Single-family Home	3.4 persons/unit	
Population Density – Semi-detached Home	2.7 persons/unit	
Population Density – Townhome or Terrace Flat	1.8 persons/unit	
Population Density – Bachelor Apartment	1.4 persons/unit	✓
Population Density – Bachelor + Den Apartment	1.4 persons/unit	
Population Density – One Bedroom Apartment	1.4 persons/unit	✓
Population Density – One Bedroom plus Den Apartment	1.4 persons/unit	
Population Density – Two Bedroom Apartment	2.1 persons/unit	✓
Population Density – Two Bedroom plus Den Apartment	2.1 persons/unit	
Population Density – Three Bedroom Apartment	3.1 persons/unit	
Average Day Demands – Residential	280 L/person/day	✓
Average Day Demands – Commercial / Institutional	28,000 L/gross ha/day	
Average Day Demands – Light Industrial / Heavy Industrial	35,000 or 55,000 L/gross ha/day	
Maximum Day Demands – Residential	2.5 x Average Day Demands	✓
Maximum Day Demands – Commercial / Institutional	1.5 x Average Day Demands	
Peak Hour Demands – Residential	5.5 x Average Day Demands	✓
Peak Hour Demands – Commercial / Institutional	2.7 x Average Day Demands	
Fire Flow Requirements Calculation	FUS	✓
Depth of Cover Required	2.4m	✓
Maximum Allowable Pressure	551.6 kPa (80 psi)	✓
Minimum Allowable Pressure	275.8 kPa (40 psi)	✓
Minimum Allowable Pressure during fire flow conditions	137.9 kPa (20 psi)	✓

## 5.5 Estimated Water Demands

The following

Table 5-2 below summarizes the anticipated water demands for the proposed development based on following:

229 Beechwood Ave. Building having 42 residential units. Estimated residential population of 65 persons.

241 Beechwood Ave. Building having 52 residential units. Estimated residential population of 81 persons.

**Table 5-2 : Water Demand Summary**

Water Demand Conditions	229 Beechwood Water Demands (L/sec)	241 Beechwood Water Demands (L/sec)	Total Water Demands (L/sec)
Average Day	0.21	0.22	0.43
Max Day	1.18	1.21	2.39
Peak Hour	1.79	1.82	3.61

## 5.6 Boundary Conditions

Hydraulic Grade Line (HGL) boundary conditions were obtained from the City for design purposes. A copy of the correspondence received from the City is provided in **Appendix B**.

The following hydraulic grade line (HGL) boundary conditions were provided:

- Minimum HGL = 107.8 m
- Maximum HGL = 118.2 m
- Connection A: Max Day + Fire Flow (217 L/s) = 102.0 m
- Connection B: Max Day + Fire Flow (250 L/s) = 100.2 m
- The provided HGL ranges of 107.8 m – 118.2 m were used to estimate pressures at the building. Under Max Day Plus fire flow conditions, the HGL of 102.0 m and 100.2 m was used for 229 and 241 Beechwood Avenue respectively.

## 5.7 Fire Flow Requirements

Water for fire protection will be available utilizing the proposed fire hydrants located along on Beechwood Avenue. The required fire flows for the proposed buildings were calculated based on typical values as established by the Fire Underwriters Survey 1999 (FUS).

The following equation from the Fire Underwriters document “Water Supply for Public Fire Protection”, 1991, was used for calculation of the on-site supply rates required to be supplied by the hydrants:

$$F = 200 * C * \sqrt{A}$$

where:

- F = Required Fire flow in Litres per minute
- C = Coefficient related to type of Construction
- A = Total Floor Area in square metres

**Table 5-3** summarizes the parameters used for estimating the Required Fire Flows (RFF) based on the Fire Underwriters Survey (FUS) and the latest City of Ottawa Technical Bulletins. The RFFs were estimated in accordance with ISTB-2018-02, and based on floor areas provided by the architect, which are illustrated in **Appendix D**. The following summarizes the parameters used for both proposed buildings.

- Type of Construction Non-combustible
- Occupancy Limited combustible

**Table 5-3 - Summary of Design Parameters Used in Calculating Required Fire Flows (RFF) Using FUS**

Design Parameter	Value
Coefficient Related to type of Construction C	1.0 (229 Beechwood) 1.0 (241 Beechwood)
Total Floor Area (m2)	2,295 (229 Beechwood) 2,801 (241 Beechwood)
Fire Flow. Prior to rounding to closest 1,000 (L/min),	9,817 (229 Beechwood) 11,022 (241 Beechwood)
Fire Flow. Rounded to closest 1,000 (L/min),	10,000 (229 Beechwood) 11,000 (241 Beechwood)
Reduction Due to Occupancy Non-combustible (-25%), Limited Combustible (-15%), Combustible (0%), Free Burning (+15%), Rapid Burning (+25%)	-15% (229 Beechwood) -15% (241 Beechwood)
Reduction due to Sprinkler (Max 50%) Sprinkler Conforming to NFPA 13 (-30%), Standard Water Supply (-10%), Fully Supervised Sprinkler (-10%)	0% (229 Beechwood) 0% (241 Beechwood)
Exposures	+56% (229 Beechwood) +56% (241 Beechwood)
Required Fire Flow, RFF, before rounded to closest 1,000 (L/min)	13,260 (229 Beechwood) 14,586 (241 Beechwood)

The estimated required fire flows (RFF) rounded to the closest 1,000, based on the FUS methods are: 13,000 L/min (or 217 L/sec) for 229 Beechwood Ave. and 15,000 L/min (or 250 L/sec) for 241 Beechwood Ave. Please refer to **Table A-3** and **Table A-4** in **Appendix A**.

## 5.8 Review of Hydrant Spacing

A review of the hydrant spacing was completed to ensure compliance with Appendix I of Technical Bulletin ISTB-2018-02. As per Section 3 of Appendix I all hydrants within 150 metres were reviewed to assess the total possible available flow from these contributing hydrants.

For each hydrant the distance to the proposed building was determined to arrive at the contribution of fire flow from each. All hydrants are expected to be of Class AA as per Section 5.1 of Appendix I. For each hydrant the straight-line distance, distance measured along a fire route or roadway, whether its location is accessible, and its contribution to the required fire flow.

Figure 5-2 below illustrates all the hydrants that are within the 75 metre and 150 metre offsets from the subject property. Fire hydrants that are denoted with a number having a HP versus H represents a PRIVATE hydrant rather than a CITY owner hydrant.

All hydrants were reviewed to determine if they were accessible or non-accessible. A hydrant would not be accessible if they were located on the opposite side of a median, limiting fire truck access.

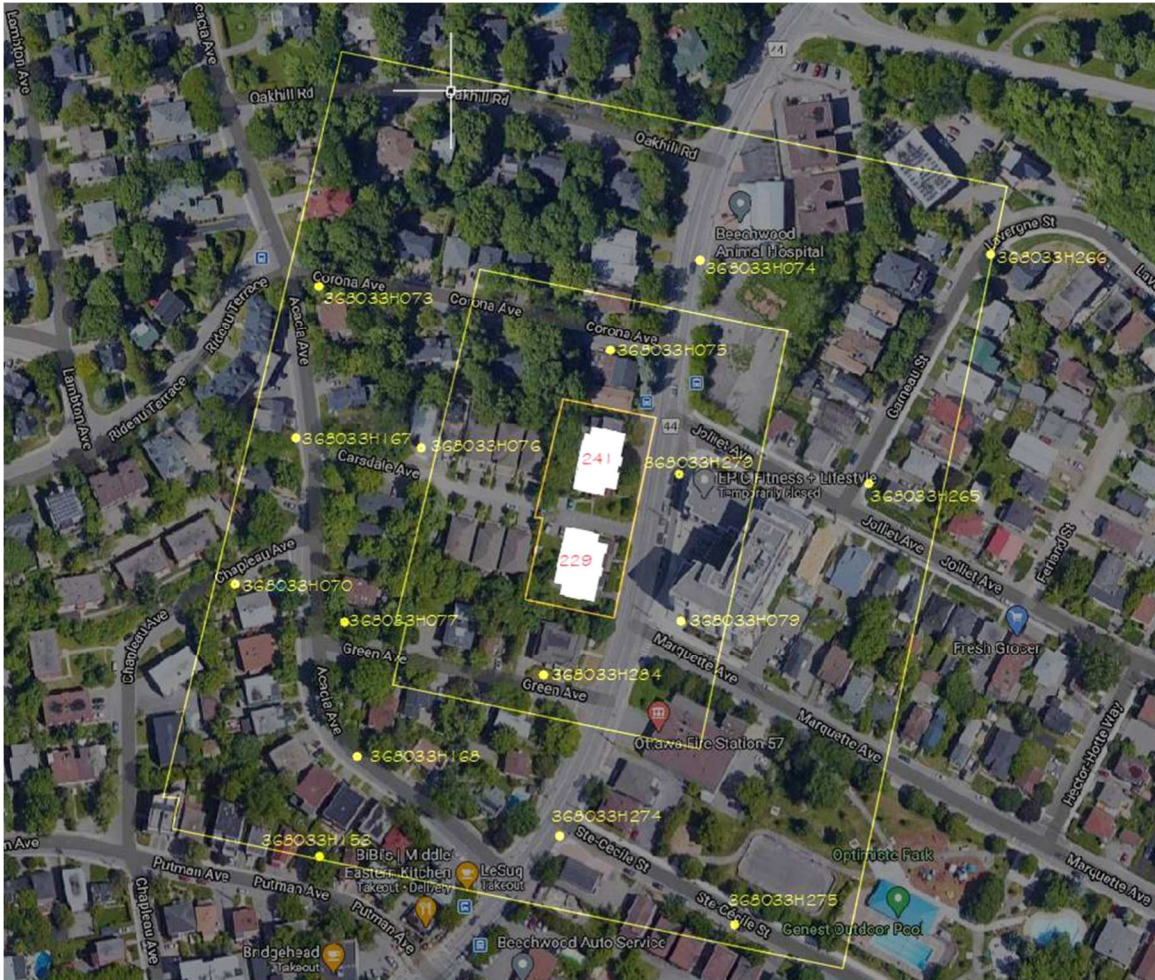

Figure 5-2 – Review of Hydrant Spacing

A summary table of the total fire flows available versus the required fire flows (RFFs) is presented in **Table 5-4** below. Detailed calculations of the available fire flows based on hydrant spacing is provided in **Table A-7** in **Appendix A**.

Table 5-4 –Fire Flows Based on Hydrant Spacing

Building	Required Fire Flow (L/min)	Available Fire Flow Based on Hydrant Spacing as per ISTB-2018-02 (L/min)
229 Beechwood	13,000 (or 217 L/sec)	15,200
241 Beechwood	15,000 (or 250 L/sec)	17,100

The total available contribution of flow from hydrants was estimated at 15,200 L/min for 229 Beechwood Ave. and 17,100 L/min for 241 Beechwood Ave. The maximum required fire flow (RFF) is 13,000 L/min for 229 Beechwood Ave

and 15,000 L/min for 241 Beechwood Ave. Therefore, the available flows from hydrants exceed each building's fire flow requirements as identified in Appendix I of Technical Bulletin ISTB-2018-02.

## 6 Sewage Servicing

### 6.1 Existing Sewage Conditions

Sewage is currently discharged easterly to the existing 300mm dia. local sanitary sewer on Beachwood Avenue, which then discharges southerly to the Vanier Parkway Collector and then westerly.

### 6.2 Proposed Sewage Conditions

It is proposed to provide separate sanitary sewer connections from each building to a sanitary manhole on site, which will then discharge to the 300mm dia. sanitary sewer on Beechwood Ave. These manholes will be installed in the frontage of each building, on Beechwood Avenue, and be used as a monitoring manhole. The sanitary sewer system was designed based on a population flow with an area-based infiltration allowance. A 150mm diameter sanitary sewer is proposed with a minimum 2% slope, having a capacity of 21.5 L/sec based on Manning's Equation under full flow conditions. **Table 6-1** below summarizes the design parameters used.

**Table 6-1 – Summary of Wastewater Design Criteria / Parameters**

Design Parameter	Value	Applies
Population Density – Single-family Home	3.4 persons/unit	
Population Density – Semi-detached Home	2.7 persons/unit	
Population Density – Duplex	2.3 persons/unit	
Population Density – Townhome (row)	2.7 persons/unit	
Population Density – Bachelor Apartment	1.4 persons/unit	✓
Population Density – Bachelor + Den Apartment	1.4 persons/unit	
Population Density – One Bedroom Apartment	1.4 persons/unit	✓
Population Density – One Bedroom plus Den Apartment	1.4 persons/unit	
Population Density – Two Bedroom Apartment	2.1 persons/unit	✓
Population Density – Two Bedroom plus Den Apartment	2.1 persons/unit	
Population Density – Three Bedroom Apartment	3.1 persons/unit	
Population Density – Three Bedroom plus Den Apartment	3.1 persons/unit	
Average Daily Residential Sewage Flow	280 L/person/day	✓
Average Daily Commercial / Intuitional Flow	28,000 L/gross ha/day	
Average Light / Heavy Industrial Daily Flow	35,000 / 55,000 L/gross ha/day	
Residential Peaking Factor – Harmon Formula (Min = 2.0, Max =4.0, with K=0.8)	$M = 1 + \frac{14}{4 + P^{0.5}} * k$	✓
Commercial Peaking Factor	1.0-1.5	
Institutional Peaking Factor	1.5	
Industrial Peaking Factor	As per Table 4-B (SDG002)	

Unit of Peak Extraneous Flow (Dry Weather / Wet Weather)	0.05 or 0.28 L/s/gross ha	
Unit of Peak Extraneous Flow (Total I/I)	0.33 L/s/gross ha	✓

The estimated peak sanitary flow rate from the proposed property is **0.85 L/sec** and **1.06 L/sec** for 229 and 241 Beechwood Ave, respectively based on City Design Guidelines. Sewage rates below include a total infiltration allowance of 0.33 L/ha/sec based on the total gross site area.

**Table 6-2 – Summary of Anticipated Sewage Rates**

Sewage Condition	229 Beechwood Ave Sanitary Sewage Flow (L/sec)	241 Beechwood Ave Sanitary Sewage Flow (L/sec)
Peak Residential Sewage Flow	0.82	1.03
Infiltration Flow (at 0.33 L/ha/sec)	0.03	0.03
Peak Wet Weather Sewage Flow	0.85	1.06

The City of Ottawa was contacted to discuss the downstream sanitary sewer and to determine if any additional analysis would be required to support this Zoning By-law application.

As each building will require its own sanitary sewer connection, 150mm diameter PVC sewers, each having a slope of 2.0% will be installed. The estimated capacity of each 150mm pipe at 2% is 21.5 L/sec.

Drawing **C100** in **Appendix D** illustrates the sanitary servicing of the property.

## 7 Storm Servicing & Stormwater Management

Since the subject properties are located within the Rideau Valley Conservation Authority (RVCA) sub watershed, Lower Rideau River Falls catchment, stormwater works are therefore subject to both the RVCA and City of Ottawa (COO) approval.

The proposed stormwater system is designed in conformance with the latest version of the City of Ottawa Design Guidelines (October 2012). Section 5 “Storm and Combined Sewer Design” and Section 8 “Stormwater Management”. A summary of the design criteria that relates to this design report is the proceeding sections below.

### 7.1 Minor System Design Criteria

The storm sewer was sized based on the Rational Method and Manning’s Equation under free flow conditions for the 2-year storm using a 10-minute inlet time.

The allowable discharge from the site shall be controlled to 2-year rate with a runoff coefficient of not less than 0.50.

Onsite storage shall be provided up to the 100-year event based on the controlled allowable discharge previously noted.

The minimum orifice dia. for a plug style ICD is 83mm and the minimum flow rate from a vortex ICD is recommended at 6.0 L/s in order to reduce the likelihood of plugging.

Minimum sewer slopes to be based on minimum velocities for storm sewers of 0.80 m/sec.



## 7.2 Major System Design Criteria

As per Technical Bulletin PIEDTB-2016-01 section 8.3.11.1 (p.12 of 14) there shall be no surface ponding on private parking areas during the 2-year storm rainfall event. Depending on the SWM strategy proposed underground or additional underground storage may be required to satisfy this requirement.

The major system has been designed to accommodate on-site detention with sufficient capacity to attenuate the 100-year design storm. On-site storage is calculated based on the 100-year design storm with on-site detention storage provided within the underground stormwater storage chambers (stormwater cistern).

Overland flow routes are provided.

The vertical distance from the spill elevation on the street and the ground elevation at the buildings is at least 150mm.

The emergency overflow spill elevation is at least 300mm below the lowest building opening.

## 7.3 Runoff Coefficients

Runoff coefficients used for were based on actual areas taken from CAD. Runoff coefficients for impervious surfaces (roofs, asphalt, and concrete) were taken as 0.90, whereas those for pervious surfaces (grass/landscaping) were taken as 0.20. Average runoff coefficients were calculated for catchments (or drainage areas) using weighted average method. The runoff coefficients for pre-development and post-development catchments are provided in **Table A-10** and **Table A-13** and summarized in **Table 7-1** below. It should be noted that a pre-development runoff coefficient of 0.51 was calculated, however 0.50 was used as per City guidelines.

**Table 7-1 – Summary of Runoff Coefficients**

Location	Area (hectares)	Pre-Development Runoff Coefficient, $C_{AVG}$	Post-Development Runoff Coefficient, $C_{AVG}$
Entire Site	0.2105	0.51	0.69

## 7.4 Pre-Development Conditions

Under current conditions, it appears that stormwater runoff from the 0.2105-hectare site flows overland towards Beechwood Ave. The overland flow route for stormwater is east towards Beechwood Ave. **Table 7-2** below summarizes the estimated peak flows under pre-development conditions using the standard 10-minute time of concentration (time to inlet).

**Table 7-2 – Summary of Pre-Development Flows**

Return Period Storm	Total Peak Flows (L/sec)
2-year	22.3
5-year	50.2
100-year	64.7

## 7.5 Allowable Release Rate

Rather than meeting pre-development released rates, the City of Ottawa imposes a more restrictive stormwater release rate as noted in Section 8.3.7.3 of the SDG002. The allowable discharge release rate from the site was established using the peak flows derived based on a 2-year return period storm, a maximum runoff coefficient of 0.50 and a standard time of concentration of 10 minutes.

The allowable release rate of 11.35 L/sec and 11.12 L/sec 229 and 241 Beechwood respectively will be based on a 2-year storm event. **Table A-12** provides detailed calculations on the total allowable peak flow.

## 7.6 Proposed Stormwater System

Stormwater runoff from the proposed site will drain from a combination of controlled and uncontrolled areas. Although there is no change in the runoff coefficient a reduction in the allowable release rate will result in control of runoff and stormwater detention. A storm drainage plan is illustrated on **Figure 7-1** below. A total of six (6) subcatchments (or drainage areas) within the development site are shown on this drawing with average runoff coefficients calculated for each drainage area. The stormwater works shall consist of the following elements:

Runoff from the roofs will be drained through WATTS Adjustable Flow Controlled Roof Drains and down to a underground storage tank below the garage of each building. The flow controlled roof drains will allow for ponding storage on each roof before draining to the underground storage tanks. Each storage tank will measure 8m x 3m x 1.5m (storing a total volume of 36.0m<sup>3</sup>) and the exact location will be coordinated with the mechanical and structural engineers during the building permit submission. In the rear yard, runoff will collected by catch basins and catch basin manholes. The rear yard drainage will then be discharged into the storage tank below the parking garage of the respective buildings. Each stormwater tank will have a Tempest LMF 75 ICD to restrict the outlet flow to a maximum of 6.0 L/sec. The stormwater then discharges out of the storage tanks of the respective buildings, through a 200 mm dia. storm pipe at a maximum flow rate of 6.0 L/sec and into the 1200 mm dia. storm sewer on Beechwood Ave.



**Figure 7-1 – Post-Development Storm Drainage**

Additional information on the estimated 100-year volumes is provided in **Table A-19** and **Table A-20** in **Appendix A**. **Table 7-3** and **Table 7-34** below provide a summary of the stormwater peak flows under post-development conditions for each building.

**Table 7-3 – Summary of Post-Development Flows (229 Beechwood)**

Return Period Storm	Max Allowable Peak Flow (L/sec)	<sup>1</sup> Total Uncontrolled Peak Stormwater Flows (L/sec)	<sup>2</sup> Total Controlled Peak Stormwater Flows (L/sec)
2-year	11.35 L/sec Based on 2-year Storm and C=0.50	15.78	3.75
5-year		21.40	5.09
100-year		42.09	10.15

Note 1-Uncontrolled peak flows, or peak flows that would result if no flow control used.  
 Note 2-Contolled flows.

**Table 7-4 – Summary of Post-Development Flows (241 Beechwood)**

Return Period Storm	Max Allowable Peak Flow (L/sec)	<sup>1</sup> Total Uncontrolled Peak Stormwater Flows (L/sec)	<sup>2</sup> Total Controlled Peak Stormwater Flows (L/sec)
2-year	11.12 L/sec Based on 2-year Storm and C=0.50	15.19	3.73
5-year		19.61	5.06
100-year		40.55	10.10
<i>Note 1-Uncontrolled peak flows, or peak flows that would result if no flow control used.</i> <i>Note 2-Controlled flows.</i>			

Since flow control is being utilized onsite, it is necessary to provide appropriate flow attenuation (storage). Additional information on the estimated 100-year volumes is provided in **Section 7.7** below.

## 7.7 Flow Attenuation & Storage

The attenuation of stormwater will be achieved by utilizing storage tanks below the parking garage of each building, ponding on the roof areas and drainage through Watts Adjustable Flow Control Drains, and storage in pipes/manholes. Using the allowable release rates, the Modified Rational Method was used to determine the 2-year, 5-year, and 100-year volumes that will occur for corresponding release rates.

**Table A-19** and **Table A-20** provide the storage volumes necessary in the below grade stormwater storage units, storage on the roof and in pipes/manholes to attenuate the controlled release rates. **Table A-15** breaks down the storage and release rates of each different method of storage. **Table A-14** summarizes the combined controlled and uncontrolled flows leaving the subject site.

The total estimated required storages in a 100-year storm event are **35.0 m<sup>3</sup>** and **34.2 m<sup>3</sup>** for 229 and 241 Beechwood Ave respectively. Roof ponding on the upper roof levels will account for **9.69 m<sup>3</sup>** and **9.74 m<sup>3</sup>**, underground storage tanks will account for **36.00 m<sup>3</sup>** and **36.00 m<sup>3</sup>** and pipes/manholes will account for **5.03 m<sup>3</sup>** and **5.11 m<sup>3</sup>** for 229 and 241 Beechwood respectively. The total storage provided for 229 Beechwood is **50.72 m<sup>3</sup>** and the total storage for 241 Beechwood is **50.84 m<sup>3</sup>**. Both volumes exceed the required storages.

## 7.8 Quality Control

Due to quality control being handled in the existing infrastructure and stormwater being outlet to the Ottawa River over 2000m downstream, there is no need for addition quality control.

## 8 Erosion & Sediment Control

During all construction activities, erosion and sedimentation shall be controlled by the following techniques:

Filter cloth shall be installed between the frame and cover of all adjacent catch basins and catch basin manhole structures.

Heavy duty silt fencing will be used to control runoff around the construction area. Silt fencing locations are identified on the site grading and erosion control plan.

A mud mat will be installed at the construction entrance to help avoid mud from being transported to offsite roads.

Visual inspection shall be completed daily on sediment control barriers and any damage repaired immediately. Care will be taken to prevent damage during construction operations.

In some cases, barriers may be removed temporarily to accommodate the construction operations. The affected barriers will be reinstated at night when construction is completed.

Sediment control devices will be cleaned of accumulated silt as required. The deposits will be disposed of as per the requirements of the contract.

During construction, if the engineer believes that additional prevention methods are required to control erosion and sedimentation, the contractor will install additional silt fences or other methods as required to the satisfaction of the engineer.

Construction and maintenance requirements for erosion and sediment controls are to comply with Ontario Provincial Standard Specification (OPSS) OPSS 805 and City of Ottawa specifications.

## 9 Conclusions and Recommendations

This Servicing & Stormwater Report outlines the rationale which will be used to service the proposed development. The following summarizes the servicing requirements for the site:

### Water

A 100 mm watermain is proposed to service 229 and 241 Beechwood Ave, as the average day demands does not exceed 50 m<sup>3</sup> per day, it is not mandatory to provide twin services as per Section 4.31 of the WDG001.

The Required Fire Flows (RFFs) were estimated at **13,000 L/min** (217 L/sec) for 229 Beechwood Ave, and **15,000 L/min** (250 L/sec) for 241 Beechwood Ave. The total minimum available flows for firefighting purposes, based on the contribution from hydrants, was estimated at **15,200 L/min** and **17,100 L/min** for each building respectively.

Based on hydraulic boundary conditions (HGL) provided by the City of Ottawa, a system pressure between  $\pm 61$  psi –  $\pm 63$  psi under peak hourly + Fire Flow demands is anticipated at the proposed building. System pressure between  **$\pm 72$  psi –  $\pm 86$  psi** under min/max HGL. This exceeds the City's guideline of 40 psi; however, it is anticipated that pressure above 80 psi will occur, therefore pressure reducing valves will be used to used the pressure in each building remains between 80 psi.

### Sewage

Estimated peak sewage flows of **0.85 L/sec** and **1.06 L/sec** are anticipated for 229 and 241 Beechwood respectively.

### Stormwater

For the stormwater system, the allowable capture rate from the entire site was calculated based on a runoff coefficient of 0.50, time of concentration of 10 minutes for a 2-year storm event. The allowable release rate for the entire site was calculated to be **11.35 L/sec** and **11.12 L/sec** for 229 and 241 Beechwood respectively. Runoff in excess of this will be detained on the roof, in underground storage tanks, and in pipes/manholes for up to the 100-year storm.

Runoff from the roofs will be drained through WATTS Adjustable Flow Controlled Roof Drains and down to a underground storage tank below the garage of each building. The flow controlled roof drains will allow for ponding storage on each roof before draining to the underground storage tanks. Each storage tank will measure 8m x 3m x 1.5m (storing a total volume of 36.0m<sup>3</sup>) and the exact location will be coordinated with the mechanical and structural engineers during the building permit submission. In the rear yard, runoff will be collected by catch basins and catch basin manholes. The rear yard drainage will then be discharged into the storage tank below the parking garage of the respective buildings. Each stormwater tank will have a Tempest LMF 75 ICD to restrict the outlet flow to a maximum of 6.0 L/sec. The stormwater then discharges out of the storage tanks of the respective buildings, through a 200 mm dia. storm pipe at a maximum flow rate of 6.0 L/sec and into the 1200 mm dia. storm sewer on Beechwood Ave.

The total estimated required storages in a 100-year storm event are **35.0 m<sup>3</sup>** and **34.2 m<sup>3</sup>** for 229 and 241 Beechwood Ave respectively. Roof ponding on the upper roof levels will account for **9.69 m<sup>3</sup>** and **9.74 m<sup>3</sup>**, underground storage tanks will account for **36.00 m<sup>3</sup>** and **36.00 m<sup>3</sup>** and pipes/manholes will account for **5.03 m<sup>3</sup>** and **5.11 m<sup>3</sup>** for 229 and 241 Beechwood respectively. The total storage provided for 229 Beechwood is **50.72 m<sup>3</sup>** and the total storage for 241 Beechwood is **50.84 m<sup>3</sup>**. Both volumes exceed the required storages.

Due to quality control being handled in the existing infrastructure and stormwater being outlet to the Ottawa River over 2000m downstream, there is no need for addition quality control.

## 10 Legal Notification

This report was prepared by EXP Services Inc. for the account of 229 Beechwood Holdings Inc. and 241 Beechwood Holdings Inc. C/O Bintee Dev Inc.

Any use which a third party makes of this report, or any reliance on or decisions to be made based on it, are the responsibility of such third parties. EXP Services Inc. accepts no responsibility for damages, if any, suffered by any third party as a result of decisions made or actions based on this project.

## Appendix A – Design Tables

**Table A-1 – Water Demand Chart**

**Table A-2 – Summary of Required Fire Flows (RFFs)**

**Table A-3 – Fire Flow Requirements Based on Fire Underwriters Survey (FUS) – 229 Beechwood**

**Table A-4 – Fire Flow Requirements Based on Fire Underwriters Survey (FUS) – 241 Beechwood**

**Table A-5 – Estimated Water Pressures at 229 Beechwood Ave**

**Table A-6 – Estimated Water Pressures at 241 Beechwood Ave**

**Table A-7 – Available Fire Flows Based on Hydrant Spacing**

**Table A-8 – NOT USED**

**Table A-9 – Sanitary Sewer Design Sheet**

**Table A-10 – Average Runoff Coefficients for Pre-Development Conditions**

**Table A-11 – Peak Runoff for Pre-Development Conditions**

**Table A-12 – Allowable Peak Flows (Based on Max C=0.50 with Tc=10mins & 2-yr Storm)**

**Table A-13 – Average Runoff Coefficients for Post-Development**

**Table A-14 – Summary of Post-Development Peak Flows (Uncontrolled and Controlled)**

**Table A-15 – Summary of Post Development Storage and Release Rates**

**Table A-16 – Calculation of Available Surface Storage**

**Table A-17 – Calculation of Underground Pipe Storage**

**Table A-18 – Calculation of Underground Structure Storage**

**Table A-19 – Storage Volumes for 2-year, 5-year and 100-Year Storms (MRM) (241 Beechwood Ave.)**

**Table A-20 – Storage Volumes for 2-year, 5-year and 100-Year Storms (MRM) (241 Beechwood Ave.)**

**Table A-21 – 5-Year and 100-Year Roof Design Sheet (229 Beechwood)**

**Table A-22 – 5-Year and 100-Year Roof Design Sheet (241 Beechwood)**



**TABLE A-1  
WATER DEMAND CHART**



<b>Location:</b>	229 Beechwood	<b>Population Densities (see note 3)</b>	<b>Maximum Daily Demand (note 1)</b>
<b>Project No:</b>	OTT-00238207	Single Family 3.4 person/unit	Residential <u>2.5</u> x avg. day.
<b>Designed by:</b>	A. O'Beirn	Semi-Detached 2.7 person/unit	Industrial <u>1.5</u> x avg. day.
<b>Checked By:</b>	J. Fitzpatrick	Duplex 2.3 person/unit	Commercial <u>1.5</u> x avg. day.
<b>Date Revised:</b>	Mar 2022	Townhome (Row) 2.7 person/unit	Institutional <u>1.5</u> x avg. day.
		Bachelor Apartment 1.4 person/unit	
		1 Bedroom Apartment 1.4 person/unit	<b>Peak Hourly Demand (note 1)</b>
		2 Bedroom Apartment 2.1 person/unit	Residential <u>2.2</u> x max. day. = <u>5.5</u> x avg. day.
		3 Bedroom Apartment 3.1 person/unit	Industrial <u>1.8</u> x max. day. = <u>2.7</u> x avg. day.
		4 Bedroom Apartment 4.1 person/unit	Commercial <u>1.8</u> x max. day. = <u>2.7</u> x avg. day.
		Avg. Apartment 1.8 person/unit	Institutional <u>1.8</u> x max. day. = <u>2.7</u> x avg. day.

**Water Consumption**  
Per Table 4.1 (WDG001)

Residential = 280 L/cap/day  
Commercial = 5.0 L/m<sup>2</sup>/day

Proposed Buildings	No. of Residential Units										Total Persons (pop)	Residential Demands in (L/sec)				Commercial				Total Demands (L/sec)					
	Singles/Semis/Towns				Apartments							Avg. Day Demand (L/day)	Peaking Factors (x Avg Day) (See note 2)		Max Day Demand (L/day)	Peak Hour Demand (L/day)	Area (m <sup>2</sup> )	Avg Demand (L/day)	Peaking Factors (x Avg Day)		Max Day Demand (L/day)	Peak Hour Demand (L/day)	Avg Day (L/s)	Max Day (L/s)	Max Hour (L/s)
	Single Family	Semi-Detached	Duplex	Townhome	Studio	1 Bedroom	2 Bedroom	3 Bedroom	4 Bedroom	Avg Apt.			Max Day	Peak Hour					Max Day	Peak Hour					
229 Beechwood - BSMT					9						12.6	3,528	5.55	8.38	19,586	29,556							0.04	0.23	0.34
229 Beechwood - 1st Floor					6	1	4				18.2	5,096	5.55	8.38	28,291	42,692							0.06	0.33	0.49
229 Beechwood - 2nd Floor					6	1	4				18.2	5,096	5.55	8.38	28,291	42,692							0.06	0.33	0.49
229 Beechwood - 3rd Floor					8	1	2				16.8	4,704	5.55	8.38	26,115	39,408							0.05	0.30	0.46
<b>Subtotal =</b>					<b>29</b>	<b>3</b>	<b>10</b>				<b>66</b>	<b>18,424</b>			<b>102,284</b>	<b>154,347</b>							<b>0.21</b>	<b>1.18</b>	<b>1.79</b>
241 Beechwood - BSMT					6		1				10.5	2,940	5.55	8.38	16,322	24,630							0.03	0.19	0.29
241 Beechwood - 1st Floor					8	1	3				18.9	5,292	5.55	8.38	29,379	44,334							0.06	0.34	0.51
241 Beechwood - 2nd Floor					8	1	3				18.9	5,292	5.55	8.38	29,379	44,334							0.06	0.34	0.51
241 Beechwood - 3rd Floor					8	1	3				18.9	5,292	5.55	8.38	29,379	44,334							0.06	0.34	0.51
241 Beechwood - 4th Floor					6		3				14.7	4,116	5.55	8.38	22,851	34,482							0.05	0.26	0.40
<b>Subtotal =</b>					<b>36</b>	<b>3</b>	<b>13</b>				<b>67</b>	<b>18,816</b>			<b>104,460</b>	<b>157,631</b>							<b>0.22</b>	<b>1.21</b>	<b>1.82</b>
<b>Total =</b>					<b>65</b>	<b>6</b>	<b>23</b>				<b>133</b>	<b>37,240</b>			<b>206,744</b>	<b>311,978</b>							<b>0.43</b>	<b>2.39</b>	<b>3.61</b>

- Notes**  
 1) When Population is greater than 500 persons, Max Day and Peak Hour Factors are based on Table 4.2 of City of Ottawa WDG001.  
 2) When Population is less than 500 persons, Max Day and Peak Hour Factors are based on Table 3-3 of MECP "Design Guidelines for Drinking Water Systems", 2008.  
 3) Unit densities based on Table 4.1 of City of Ottawa WDG001.

**TABLE A2**

**SUMMARY OF REQUIRED FIREFLOWS (RFFs)**

Building #	Description	<sup>1</sup> No of Storeys	Fire Flow, F (L/min)	<sup>2</sup> Type of Constr. Coeff, C	<sup>3</sup> Reduction Due to Occupancy (%)	<sup>4</sup> Reduction Due to Sprinklers (%)	<sup>5</sup> Total Increase due to Exposures (%)	<sup>6</sup> Required Fire Flow in	
								(L/min)	(L/sec)
229 BEECHWOOD AVE	Appartments	3+	10,000	1.0	-15%	0%	56%	13,000	217
241 BEECHWOOD AVE	Appartments	4+	11,000	1.0	-15%	0%	56%	15,000	250

**Notes**

- 1 - If basements are included (<50% below grade) then denoted as +.
- 2 -Types of constructions: 0.8 for non-combustible, 1.0 for ordinary construction,1.5 for wood frame construction.
- 3 - Reductions due to Occupancy are -25% for non-combustible or -15% for limited combustible.
- 4 - Reductions due to Sprinkler Systems
- 5 - Increase due to exposures were calculated based on FUS and technical bulletin ISTB-2018-02.
- 6 - Required Fire Flows are rounded to nearest 1,000 L/min.

**TABLE A3**  
**FIRE FLOW REQUIREMENTS BASED ON FIRE UNDERWRITERS SURVEY(FUS) 1999 FOR**



**229 BEECHWOOD AVE**

An estimate of the Fire Flow required for a given fire area may be estimated by:

$$F = 220 * C * \text{SQRT}(A)$$

where: F = required fire flow in litres per minute  
 A = total floor area in m<sup>2</sup> (including all storeys, but excluding basements at least 50% below grade)  
 C = coefficient related to the type of construction

Task	Options	Multiplier	Input				Value Used	Fire Flow Total (L/min)
Choose Building Frame (C)	Wood Frame	1.5	Ordinary Construction				1	
	Ordinary Construction	1						
	Non-combustible Construction	0.8						
	Fire Resistive Construction	0.6						
Input Building Floor Areas (A)			Area	% Used	Area Used	Comment		
	Floor 3		468	100%	468			
	Floor 2		608	50%	304			
	Floor 1		608	100%	608			
	BSMT		611	100%	611			
	Basement (At least 50% below grade, not included)				1,991			
Fire Flow (F)	F = 220 * C * SQRT(A)							9,817
Fire Flow (F)	Rounded to nearest 1,000							<b>10,000</b>

**Reductions/Increases Due to Factors Effecting Burning**

Task	Options	Multiplier	Input				Value Used	Fire Flow Change (L/min)	Fire Flow Total (L/min)												
Choose Combustibility of Building Contents	Non-combustible	-25%	Limited Combustible				-15%	-1,500	8,500												
	Limited Combustible	-15%																			
	Combustible	0%																			
	Free Burning	15%																			
	Rapid Burning	25%																			
Choose Reduction Due to Sprinkler System	Adequate Sprinkler Conforms to NFPA13	-30%	No Sprinkler				0%	0	8,500												
	No Sprinkler	0%																			
	Standard Water Supply for Fire Department Hose Line and for Sprinkler System	-10%								Not Standard Water Supply or Unavailable				0%	0	8,500					
	Not Standard Water Supply or Unavailable	0%																			
	Fully Supervised Sprinkler System	-10%															Not Fully Supervised or N/A				0%
Not Fully Supervised or N/A	0%																				
Choose Structure Exposure Distance	Exposures	Separation Dist (m)	Cond	Separation Conditon	Exposed Wall type	Exposed Wall Length				Total Charge (%)	Total Exposure Charge (L/min)										
						Length (m)	No of Storeys	Length-Height Factor	Sub-Condition				Charge (%)								
						Front	24	4	20.1 to 30				Type B	30	3	90	4C	8%	56%	4,760	13,260
						Side 1	4	2	3.1 to 10				Type A	18	2	36	2B	18%			
						Back	9	2	3.1 to 10				Type A	20	3	60	2B	18%			
Side 2	17	3	10.1 to 20	Type A	19	3	30	3A	12%												
Obtain Required Fire Flow	Total Required Fire Flow, Rounded to the Nearest 1,000 L/min =							<b>13,000</b>													
						Total Required Fire Flow, L/s =		<b>217</b>													

**Exposure Charges for Exposing Walls of Wood Frame Constructon (from Table G5)**

- Type A Wood-Frame or non-combustible
- Type B Ordinary or fire-resistive with unprotected openings
- Type C Ordinary or fire-resistive with semi-protected openings
- Type D Ordinary or fire-resistive with blank wall

**Conditions for Separation**

Separation Dist	Condition
0m to 3m	1
3.1m to 10m	2
10.1m to 20m	3
20.1m to 30m	4
30.1m to 45m	5
> 45.1m	6

**TABLE A4  
FIRE FLOW REQUIREMENTS BASED ON FIRE UNDERWRITERS SURVEY(FUS) 1999 FOR**



**241 BEECHWOOD AVE**

An estimate of the Fire Flow required for a given fire area may be estimated by:

$$F = 220 * C * \text{SQRT}(A)$$

where:

F = required fire flow in litres per minute  
 A = total floor area in m<sup>2</sup> (including all storeys, but excluding basements at least 50% below grade)  
 C = coefficient related to the type of construction

Task	Options	Multiplier	Input				Value Used	Fire Flow Total (L/min)
Choose Building Frame (C)	Wood Frame	1.5	Ordinary Construction				1	
	Ordinary Construction	1						
	Non-combustible Construction	0.8						
	Fire Resistive Construction	0.6						
Input Building Floor Areas (A)			Area	% Used	Area Used	Comment		
	Floor 4		489	100%	489			
	Floor 2		582	100%	582			
	Floor 2		582	50%	291			
	Floor 1		582	100%	582			
	BSMT		566	100%	566			
	Basement (At least 50% below grade, not included)				2,510			
Fire Flow (F)	F = 220 * C * SQRT(A)							11,022
Fire Flow (F)	Rounded to nearest 1,000							<b>11,000</b>

**Reductions/Increases Due to Factors Effecting Burning**

Task	Options	Multiplier	Input				Value Used	Fire Flow Change (L/min)	Fire Flow Total (L/min)								
Choose Combustibility of Building Contents	Non-combustible	-25%	Limited Combustible				-15%	-1,650	9,350								
	Limited Combustible	-15%															
	Combustible	0%															
	Free Burning	15%															
	Rapid Burning	25%															
Choose Reduction Due to Sprinkler System	Adequate Sprinkler Conforms to NFPA13	-30%	No Sprinkler				0%	0	9,350								
	No Sprinkler	0%															
	Standard Water Supply for Fire Department Hose Line and for Sprinkler System	-10%	Not Standard Water Supply or Unavailable				0%	0	9,350								
	Not Standard Water Supply or Unavailable	0%															
	Fully Supervised Sprinkler System	-10%															
Not Fully Supervised or N/A	0%	Not Fully Supervised or N/A				0%	0	9,350									
Choose Structure Exposure Distance	Exposures	Separation Dist (m)	Cond	Separation Condition	Exposed Wall type	Exposed Wall Length				Total Charge (%)	Total Exposure Charge (L/min)						
						Length (m)	No of Storeys	Length-Height Factor	Sub-Condition								
						Front	27	4	20.1 to 30			Type B	18	4	72	4C	8%
						Side 1	17	3	10.1 to 20			Type A	19	3	57	3B	13%
						Back	9	2	3.1 to 10			Type A	20	3	60	2B	18%
Side 2	5	2	3.1 to 10	Type A	18	3	30	2A	17%								
Obtain Required Fire Flow	Total Required Fire Flow, Rounded to the Nearest 1,000 L/min =						<b>15,000</b>										
	Total Required Fire Flow, L/s =						<b>250</b>										

**Exposure Charges for Exposing Walls of Wood Frame Construction (from Table G5)**

- Type A Wood-Frame or non-combustible
- Type B Ordinary or fire-resistive with unprotected openings
- Type C Ordinary or fire-resistive with semi-protected openings
- Type D Ordinary or fire-resistive with blank wall

**Conditions for Separation**

Separation Dist	Condition
0m to 3m	1
3.1m to 10m	2
10.1m to 20m	3
20.1m to 30m	4
30.1m to 45m	5
> 45.1m	6

**TABLE A5**

**ESTIMATED WATER PRESSURE AT PROPOSED BUILDING (229 Beechwood Ave)**

Description	From	To	Demand (L/sec)	Pipe Length (m)	Pipe Dia (mm)	Dia (m)	Slope of HGL (m/m)	Head Loss (m)	Elev From (m)	Elev To (m)	*Elev Diff (m)	Pressure From (kPa (psi))	Pressure To (kPa (psi))	Pressure Drop (psi)
<b>Peak Hour Conditons</b>														
50mm service	Main	Basement	1.790	18 m	50	0.050	0.03735	0.6724	55.50	56.20	-0.7	436.5 (63.3)	423.1 (61.4)	2.0
	Basement	Top floor	0.448	10 m	38	0.038	0.01091	0.1128	56.20	69.24	-13.0	423.1 (61.4)	294.1 (42.6)	18.7
100mm service	Main	Basement	1.790	18 m	100	0.100	0.00128	0.023	55.50	56.20	-0.7	436.5 (63.3)	429.5 (62.3)	1.0
	Basement	Top floor	0.448	10 m	38	0.038	0.01091	0.1128	56.20	69.24	-13.0	429.5 (62.3)	300.4 (43.6)	18.7

**Water Demand Info**

Average Demand = 0.21 L/sec  
 Max Day Demand = 1.18 L/sec  
 Peak Hr Deamand = 1.79 L/sec

Fireflow Requiriement = 216 L/sec  
 Max Day Plus FF Demand = 217.2 L/sec

**Boundary Conditon**

	<u>Min HGL</u>	<u>Max HGL</u>	<u>Peak Hour+FF HGL</u>
HGL (m)	107.8	118.2	102.0
Approx Ground Elev (m) =	57.5	57.5	57.5
Pressure (m) =	50.3	60.7	44.5
Pressure (Pa) =	493,443	595,467	436,545
Pressure (psi) =	71.6	86.4	63.3

**Pipe Lengths**

From watermain to building mech room= 18 m  
 From mech room to centre top floor = 10.3 m  
 Hazen Williams C Factor for Friction Loss in Pipe, C= 100

**Elevations**

At roadway = 57.50  
 At building (mech room FF) = 58.90  
 Centre of top floor = 69.24

<----- (From City of Ottawa at connection point)

**TABLE A6**

**ESTIMATED WATER PRESSURE AT PROPOSED BUILDING (241 Beechwood Ave)**

Description	From	To	Demand (L/sec)	Pipe Length (m)	Pipe Dia (mm)	Dia (m)	Slope of HGL (m/m)	Head Loss (m)	Elev From (m)	Elev To (m)	*Elev Diff (m)	Pressure From (kPa (psi))	Pressure To (kPa (psi))	Pressure Drop (psi)
<b>Peak Hour Conditons</b>														
50mm service	Main	Basement	1.820	19 m	50	0.050	0.03852	0.7319	56.50	56.95	-0.5	418.9 (60.8)	407.3 (59.1)	1.7
	Basement	Top floor	0.455	14 m	38	0.038	0.01125	0.1578	56.95	72.93	-16.0	407.3 (59.1)	249.0 (36.1)	23.0
100mm service	Main	Basement	1.820	19 m	100	0.100	0.00132	0.025	56.50	56.95	-0.5	418.9 (60.8)	414.2 (60.1)	0.7
	Basement	Top floor	0.455	14 m	38	0.038	0.01125	0.1578	56.95	72.93	-16.0	414.2 (60.1)	255.9 (37.1)	23.0

**Water Demand Info**

Average Demand = 0.22 L/sec  
 Max Day Demand = 1.21 L/sec  
 Peak Hr Deamand = 1.82 L/sec

Fireflow Requiriement = 250 L/sec  
 Max Day Plus FF Demand = 251.2 L/sec

**Boundary Conditon**

	<u>Min HGL</u>	<u>Max HGL</u>	<u>Peak Hour+FF HGL</u>
HGL (m)	107.8	118.2	100.2
Approx Ground Elev (m) =	57.5	57.5	57.5
Pressure (m) =	50.3	60.7	42.7
Pressure (Pa) =	493,443	595,467	418,887
Pressure (psi) =	71.6	86.4	60.8

**Pipe Lengths**

From watermain to building mech room= 19 m  
 From mech room to centre top floor = 14.0 m  
 Hazen Williams C Factor for Friction Loss in Pipe, C= 100

**Elevations**

At roadway = 58.60  
 At building (mech room FF) = 58.90  
 Centre of top floor = 72.93

<----- (From City of Ottawa at connection point)

**TABLE A7  
FIRE FLOW REQUIREMENTS BASED ON HYDRANT SPACING**

Hydrant #	229 Beechwood Ave.		241 Beechwood Ave.	
	<sup>1</sup> Distance (m)	<sup>2</sup> Fire Flow Contribution (L/min)	<sup>1</sup> Distance (m)	<sup>2</sup> Fire Flow Contribution (L/min)
368033H279	61	5,700	39	5,700
368033H079	72	5,700	98	3,800
368033H075	117	3,800	99	3,800
368033H284	169	0	131	3,800
368033H265	201	0	174	0
Total Available (L/min)	15,200		17,100	
FUS RFF in L/min or (L/sec)	13,000 (217)		15,000 (250)	
Meets Requirement (Yes/No)	Yes		Yes	
<u>Notes:</u>				
<sup>1</sup> Distance is measured along a road or fire route.				
<sup>2</sup> Fire Flow Contribution for Class AA Hydrant from Table 1 of Appendix I, ISTB-2018-02				

**Table A-9  
SANITARY SEWER CALCULATION SHEET**

LOCATION			RESIDENTIAL AREAS AND POPULAITONS										COMMERCIAL				INFILTRATION			SEWER DATA							
Street	U/S MH	D/S MH	Area (ha)	NUMBER OF UNITS					POPULATION		Peak Factor	Peak Flow (L/sec)	AREA (ha)		Peak Factor	Peak Flow (L/sec)	AREA (ha)		INFILT FLOW (L/s)	TOTAL FLOW (L/s)	Nom Dia (mm)	Actual Dia (mm)	Slope (%)	Length (m)	Capacity (L/sec)	Q/Q <sub>CAP</sub> (%)	Full Velocity (m/s)
				Single	Semi	1-Bed Apt.	2-Bed Apt.	3-Bed Apt.	INDIV	ACCU			INDIV	ACCU			INDIV	ACCU									
Beechwood	229	SANMH	0.1054			32	10		65.8	65.8	4.00	0.85					0.1054	0.105	0.03	0.89	150	135.00	2.0	8.6	16.3	5%	1.72
Beechwood	241	SANMH	0.1031			39	13		81.9	81.9	4.00	1.06					0.1031	0.103	0.03	1.10	150	135.00	2.0	9.8	16.3	7%	1.72
			<b>0.209</b>			<b>71</b>	<b>23</b>		<b>147.7</b>								<b>0.209</b>										
Residential Avg. Daily Flow, q (L/p/day) = 280 Commercial Avg. Daily Flow (L/gross ha/day) = 28,000 or L/gross ha/sec = 0.324 Institutional Avg. Daily Flow (L/s/ha) = 28,000 or L/gross ha/sec = 0.324 Light Industrial Flow (L/gross ha/day) = 35,000 or L/gross ha/sec = 0.4051 Light Industrial Flow (L/gross ha/day) = 55,000 or L/gross ha/sec = 0.637 Commercial Peak Factor = 1.5 (when area >20%) Factor = 1.0 (when area <20%) Institutional Peak Factor = 1.5 (when area >20%) Factor = 1.0 (when area <20%) Residential Correct 0.80 Manning N = 0.013 Peak extraneous flic 0.33 (Total I/I)																		Peak Population Flow, (L/sec) = P*q*M/86.4 Peak Extraneous Flow, (L/sec) = I*Ac Residential Peaking Factor, M = 1 + (14/(4+P^0.5)) * K Sewer Capacity, Qcap (L/sec) = 1/N S1 <sup>1/2</sup> R <sup>2/3</sup> Ac			Unit Type Ppu Singles = 3.4 Semi-Detached = 2.7 1-bed Apt = 1.4 1-bed + Den Apt = 1.4 2-bed Apt. Unit = 2.1 2-bed + Den Apt = 2.1 3-bed Apt. Unit = 3.1			Designed: Alexander Cole Checked: Jason Fitzpatrick, P.Eng. File Reference: OTT-00238207		Project: 229 + 241 Beechwood Location: Ottawa, Ontario Page No: 1 of 1	



**TABLE A10**  
**CALCULATION OF AVERAGE RUNOFF COEFFICIENTS FOR PRE-DEVELOPMENT CONDITIONS**

Area No.	Roof Areas		Asphalt Areas		Concrete / Pavers		Gravel		Grassed Areas		Sum AC	Total Area (m <sup>2</sup> )	C <sub>AVG</sub>
	C=0.90		C=0.90		C=0.90		C=0.75		C=0.20				
	Area (m <sup>2</sup> )	A * C	Area (m <sup>2</sup> )	A * C	Area (m <sup>2</sup> )	A * C	Area (m <sup>2</sup> )	A * C	Area (m <sup>2</sup> )	A * C			
229 Beechwood	585.60	527.0	315.00	283.5	8.30	7.5	22.90	17.2	1173.20	234.64	1069.8	1063.00	0.50
241 Beechwood	585.60	527.0	315.00	283.5	8.30	7.5	22.90	17.2	1173.20	234.64	1069.8	1042.00	0.50

**TABLE A11**  
**CALCULATION OF PEAK RUNOFF FOR PRE-DEVELOPMENT CONDITIONS**

Area No	Outlet Location	Area (ha)	Time of Conc, Tc (min)	Storm = 2 yr			Storm = 5 yr			Storm = 100 yr		
				I <sub>2</sub> (mm/hr)	Cavg	Q <sub>2</sub> (L/sec)	I <sub>5</sub> (mm/hr)	Cavg	Q <sub>5</sub> (L/sec)	I <sub>100</sub> (mm/hr)	Cavg	Q <sub>100</sub> (L/sec)
229 Beechwood	Beechwood	0.10630	10	76.81	0.50	11.3	104.19	0.50	15.4	178.56	0.63	33.0
241 Beechwood	Beechwood	0.10420	10	76.81	0.50	11.1	104.19	0.50	15.1	178.56	0.63	32.3

**Notes**

- 1) Intensity,  $I = 732.951 / (Tc + 6.199)^{0.810}$  (2-year, City of Ottawa)
- 2) Intensity,  $I = 998.071 / (Tc + 6.053)^{0.814}$  (5-year, City of Ottawa)
- 3) Intensity,  $I = 1735.688 / (Tc + 6.014)^{0.820}$  (100-year, City of Ottawa)
- 4) Cavg for 100-year is increased by 25% to a maximum of 1.0
- 5) The standard minimum Time of Concentration of 10 minutes was used, rather than the calculated time, since calculated time was less than 10 minutes.

**TABLE A12**  
**ESTIMATION OF ALLOWABLE PEAK FLOWS (Based on Max C=0.50 with Tc=10mins & 2-yr Storm)**

Area No	Outlet Location	Area (ha)	Time of Conc, Tc (min)	Storm = 2 yr			Storm = 5 yr			Storm = 100 yr		
				I <sub>2</sub> (mm/hr)	Cavg	Q <sub>ALLOW</sub> (L/sec)	I <sub>5</sub> (mm/hr)	Cavg	Q <sub>ALLOW</sub> (L/sec)	I <sub>100</sub> (mm/hr)	Cavg	Q <sub>ALLOW</sub> (L/sec)
229 Beechwood	Beechwood	0.10630	10	76.81	0.50	11.35	104.19	0.50	15.40	178.56	0.63	32.98
241 Beechwood	Beechwood	0.10420	10	76.81	0.50	11.12	104.19	0.50	15.09	178.56	0.63	32.33

**Notes**

- 1) Intensity,  $I = 732.951 / (Tc + 6.199)^{0.810}$  (2-year, City of Ottawa)
- 2) Intensity,  $I = 998.071 / (Tc + 6.053)^{0.814}$  (5-year, City of Ottawa)
- 3) Intensity,  $I = 1735.688 / (Tc + 6.014)^{0.820}$  (100-year, City of Ottawa)
- 4) Cavg for 100-year is increased by 25% to a maximum of 1.0
- 5) Allowable Discharge Rate is based on 2-year storm at Tc=10 minutes, and discharging to storm sewer on Beechwood Avenue

Allowable Discharge (based on 2-yr storm)

**TABLE A13**  
**AVERAGE RUNOFF COEFFICIENTS FOR POST-DEVELOPMENT CONDITIONS**

		$C_{ASPH/CONC} = 0.90$		$C_{ROOF} = 0.90$		$C_{GRASS} = 0.20$				
Area No.	Asphalt & Conc Areas (m <sup>2</sup> )	A * C <sub>ASPH</sub>	Roof Areas (m <sup>2</sup> )	A * C <sub>ROOF</sub>	Grassed Areas (m <sup>2</sup> )	A * C <sub>GRASS</sub>	Sum AC	Total Area (m <sup>2</sup> )	C <sub>AVG</sub> (see note)	Comment
S01			582.0	523.8			523.8	582	0.90	North Building Roof
S02	106.5	107.4			132.5	27	133.9	239	0.50	North Back Yard
S03	30.7	27.6			189.3	37.9	65.5	220	0.31	North Front Yard
S04			605.0	544.5			544.5	605	0.90	South Building Roof
S05	87.1	78.4			126.9		78.4	214	0.59	South Back Yard
S06	53.8	48.4			191.2	38.2	86.7	245	0.31	South Front Yard
<b>Totals</b>								<b>2105</b>	<b>0.69</b>	
<b>Notes</b>										
1) Cavg derived with area-weighting command in PCSWMM										

**TABLE A14**  
**SUMMARY OF POST-DEVELOPMENT PEAK FLOWS (Uncontrolled and Controlled)**

Area No	Area (ha)	Time of Conc, Tc (min)	Storm = 2 yr				Storm = 5 yr				Storm = 100 yr			
			C <sub>AVG</sub>	I <sub>2</sub> (mm/hr)	Q (L/sec)	Q <sub>CAP</sub> (L/sec)	C <sub>AVG</sub>	I <sub>5</sub> (mm/hr)	Q (L/sec)	Q <sub>CAP</sub> (L/sec)	C <sub>AVG</sub>	I <sub>100</sub> (mm/hr)	Q (L/sec)	Q <sub>CAP</sub> (L/sec)
S01	0.0582	10	0.90	76.81	11.18	(2.32)	0.90	104.19	15.17	(3.15)	1.00	178.56	28.89	(6.00)
S02	0.0239	10	0.50	76.81	2.55		0.50	104.19	3.46		0.63	178.56	7.41	
S03	0.0220	10	0.31	76.81	1.46	1.46	0.31	104.19	1.98	1.98	0.39	178.56	4.23	4.23
S04	0.0605	10	0.90	76.81	11.63	(2.32)	0.90	104.19	15.77	(3.15)	1.00	178.56	30.03	(6.00)
S05	0.0214	10	0.59	76.81	2.70		0.59	104.19	3.66		0.74	178.56	7.83	
S06	0.0245	10	0.31	76.81	1.62	1.62	0.31	104.19	2.20	2.20	0.39	178.56	4.71	4.71
<b>total (storm)</b>			<b>0.2105</b>		<b>31.14</b>	<b>7.72</b>			<b>42.24</b>	<b>10.48</b>			<b>83.12</b>	<b>20.94</b>
foundation drain (note 7)						0.90				0.90				0.90
<b>Totals</b>			<b>0.2105</b>			<b>8.623</b>				<b>11.377</b>				<b>21.84</b>
Allowable rates for comparison						22.47				22.47				22.47
<b>Notes</b>														
1) Intensity, I = 732.951/(Tc+6.199) <sup>0.810</sup> (2-year, City of Ottawa)														
2) Intensity, I = 998.071/(Tc+6.053) <sup>0.814</sup> (5-year, City of Ottawa)														
3) Intensity, I = 1735.688/(Tc+6.014) <sup>0.820</sup> (100-year, City of Ottawa)														
4) Cavg for 100-year is increased by 25% to a maximum of 1.0														
5) Time of Concentration, Tc = <b>10 mins</b>														
6) For Flows under column Qcap which are shown in brackets (0.0), denotes flows that are controlled														
7) Foundation Drain allowance based on Section 5.4.7 of SDG002 = <b>0.45 L/s/home</b>														

**TABLE A15  
SUMMARY OF POST DEVELOPMENT STORAGE & RELEASE RATES**

Area No.	Area (ha)	Max Release Rate (L/s)			<sup>1</sup> Storage Required (m <sup>3</sup> )				Storage Provided (m <sup>3</sup> )					Control Method
		2-yr	5-yr	100-yr	2-yr (MRM)	5-yr (MRM)	100-yr (MRM)	100-yr +20 (MRM)	Roof Storage	Pipe	UG CB/MHs	UG Chamber	Total	
S01	0.0582	2.32	3.15	6.00	8.7	11.7	34.2	43.5	9.74				9.74	Roof Drains
S02	0.0239									0.80	4.31	36.00	41.11	Underground Storage
S03	0.0220	1.46	4.23	4.23										none
Subtotal (241 Beechwood)		3.78	7.38	10.23	8.71	11.69	34.18	43.53	9.74	0.80	4.31	36.00	50.84	
S04	0.0605	2.32	3.15	6.00	9.3	12.4	35.0	44.6	9.69				9.69	Roof Drains
S05	0.0214									1.05	3.98	36.00	41.03	Underground Storage
S06	0.0245	1.62	4.71	4.71										none
Subtotal (229 Beechwood)		3.94	7.86	10.71	9.26	12.43	35.01	44.60	9.69	1.05	3.98	36.00	50.72	
Totals		0.2105	7.72	15.25	20.94	17.97	24.12	69.20	88.13	19.42	2.65	12.60	108.00	101.56
<u>Notes</u>														
1) The storage required is based on the Modified Rational Method (MRM) for the release rates noted.														

**TABLE A16****CALCULATION OF AVAILABLE SURFACE STORAGE**

Drainage Area	Ponding Number	Min W/L or T/G (m)	Indiv Spill Elev (m)	<sup>1</sup> Max Depth (m)	Area (m <sup>2</sup> )	Max Volume (m <sup>3</sup> )
S01				0.00	28	0.0
S02				0.00	28	0.0
S03				0.00	28	0.0
S04				0.00	28	0.0
S05				0.00	28	0.0
S06				0.00	28	0.0
<b>Totals</b>						<b>0.0</b>
<i>Notes:</i> The Max Depth is the distance from the Min W/L (T/G) and the lower of the Indiv Spill or System Spill Elev						

**TABLE A17****CALCULATION OF UNDERGROUND PIPE STORAGE**

Drainage Area	U/S Manhole	D/S Manhole	Pipe Type	Length (m)	Pipe Dia (mm)	Pipe Area (m <sup>2</sup> )	Pipe Volume (m <sup>3</sup> )
S01							
S02			PVC	16.1	200	0.031	0.51
			PVC	16.6	150	0.018	0.29
S03							
S04							
S05			PVC	13.9	200	0.031	0.44
			PVC	34.6	150	0.018	0.61
S06							
<b>Totals</b>							<b>1.85</b>

**TABLE A18****CALCULATION OF UNDERGROUND STRUCTURE STORAGE**

Drainage Area	Structure No.	Size	T/G (m)	Spill Elev (m)	Inv Elev (m)	Sump Elev (m)	<sup>1</sup> Storage Depth (m)	Area (m <sup>2</sup> )	Volume (m <sup>3</sup> )
S01									
S02	CBMH 3	1200 dia	60.69	60.18	58.45	58.45	1.73	1.13	1.96
	CBMH 4	1200 dia	60.65	60.18	58.10	58.10	2.08	1.13	2.35
S03									
S04									
S05	CBMH 1	1200 dia	59.26	59.06	57.16	57.16	1.90	1.13	2.15
	CBMH 2	1200 dia	60.67	59.06	57.44	57.44	1.62	1.13	1.83
S06									
<b>Totals</b>									<b>8.29</b>
<i>Notes:</i> The Storage Depth is the distance from the invert elevation to either the T/G or Spill Elev (whichever is lower)									

**TABLE A19 Storage Volumes for 2-year, 5-Year and 100-Year Storms (MRM) (229 Beechwood Ave.)**

Area No: <b>S04, S05</b> $C_{AVG} = 0.82$ (2-yr) $C_{AVG} = 0.82$ (5-yr) $C_{AVG} = 1.00$ (100-yr, Max 1.0) Time Interval = <u>10.00</u> (mins) Drainage Area = <u>0.0819</u> (hectares)																							
Actual Release Rate (L/sec) = <u>6.00</u> Percentage of Actual Rate (City of Ottawa requirement) = <u>50%</u> (Set to 50% when U/G storage used) Release Rate Used for Estimation of 100-year Storage (L/sec) = <u>3.00</u>											Intensity Incr (%) = <u>20%</u> Use 20% for Climate Change												
Duration (mins)	Release Rate = <u>2.32</u> (L/sec) Return Period = <u>2</u> (years) IDF Parameters, A = <u>733.0</u> , B = <u>0.810</u> (I = A/(T <sub>c</sub> +C), C = <u>6.199</u> )					Release Rate = <u>3.15</u> (L/sec) Return Period = <u>5</u> (years) IDF Parameters, A = <u>998.1</u> , B = <u>0.814</u> (I = A/(T <sub>c</sub> +C), C = <u>6.053</u> )					Release Rate = <u>3.00</u> (L/sec) Return Period = <u>100</u> (years) IDF Parameters, A = <u>1735.7</u> , B = <u>0.820</u> (I = A/(T <sub>c</sub> +C), C = <u>6.014</u> )					Release Rate = <u>3.00</u> (L/sec) Return Period = <u>100+20%</u> (years) IDF Parameters, A = <u>1735.7</u> , B = <u>0.820</u> (I = A/(T <sub>c</sub> +C), C = <u>6.014</u> )							
	Rainfall Intensity, I (mm/hr)	Peak Flow (L/sec)	Release Rate (L/sec)	Storage Rate (L/sec)	Storage (m <sup>3</sup> )	Rainfall Intensity, I (mm/hr)	Peak Flow (L/sec)	Release Rate (L/sec)	Storage Rate (L/sec)	Storage (m <sup>3</sup> )	Rainfall Intensity, I (mm/hr)	Peak Flow (L/sec)	Release Rate (L/sec)	Storage Rate (L/sec)	Storage (m <sup>3</sup> )	Rainfall Intensity, I (mm/hr)	Peak Flow (L/sec)	Release Rate (L/sec)	Storage Rate (L/sec)	Storage (m <sup>3</sup> )			
0	167.2	31.2	2.3	28.9	0.0	230.5	43.0	3.2	39.8	0.0	398.6	90.8	3.0	87.8	0.0	478.3	108.9	3.0	105.9	0.0			
10	76.8	14.3	2.3	12.0	7.2	104.2	19.4	3.2	16.3	9.8	178.6	40.7	3.0	37.7	22.6	214.3	48.8	3.0	45.8	27.5			
20	52.0	9.7	2.3	7.4	8.9	70.3	13.1	3.2	9.9	11.9	120.0	27.3	3.0	24.3	29.2	143.9	32.8	3.0	29.8	35.7			
30	40.0	7.5	2.3	5.1	9.3	53.9	10.1	3.2	6.9	12.4	91.9	20.9	3.0	17.9	32.3	110.2	25.1	3.0	22.1	39.8			
40	32.9	6.1	2.3	3.8	9.1	44.2	8.2	3.2	5.1	12.2	75.1	17.1	3.0	14.1	33.9	90.2	20.5	3.0	17.5	42.1			
50	28.0	5.2	2.3	2.9	8.7	37.7	7.0	3.2	3.9	11.6	64.0	14.6	3.0	11.6	34.7	76.7	17.5	3.0	14.5	43.4			
60	24.6	4.6	2.3	2.3	8.1	32.9	6.1	3.2	3.0	10.8	55.9	12.7	3.0	9.7	35.0	67.1	15.3	3.0	12.3	44.2			
70	21.9	4.1	2.3	1.8	7.4	29.4	5.5	3.2	2.3	9.8	49.8	11.3	3.0	8.3	35.0	59.7	13.6	3.0	10.6	44.5			
80	19.8	3.7	2.3	1.4	6.6	26.6	5.0	3.2	1.8	8.6	45.0	10.2	3.0	7.2	34.8	54.0	12.3	3.0	9.3	44.6			
90	18.1	3.4	2.3	1.1	5.7	24.3	4.5	3.2	1.4	7.4	41.1	9.4	3.0	6.4	34.3	49.3	11.2	3.0	8.2	44.5			
100	16.7	3.1	2.3	0.8	4.8	22.4	4.2	3.2	1.0	6.2	37.9	8.6	3.0	5.6	33.8	45.5	10.4	3.0	7.4	44.1			
110	15.6	2.9	2.3	0.6	3.8	20.8	3.9	3.2	0.7	4.8	35.2	8.0	3.0	5.0	33.1	42.2	9.6	3.0	6.6	43.7			
120	14.6	2.7	2.3	0.4	2.8	19.5	3.6	3.2	0.5	3.4	32.9	7.5	3.0	4.5	32.3	39.5	9.0	3.0	6.0	43.1			
130	13.7	2.6	2.3	0.2	1.8	18.3	3.4	3.2	0.3	2.0	30.9	7.0	3.0	4.0	31.5	37.1	8.4	3.0	5.4	42.4			
140	12.9	2.4	2.3	0.1	0.7	17.3	3.2	3.2	0.1	0.6	29.2	6.6	3.0	3.6	30.6	35.0	8.0	3.0	5.0	41.7			
150	12.3	2.3	2.3	0.0	-0.3	16.4	3.1	3.2	-0.1	-0.9	27.6	6.3	3.0	3.3	29.6	33.1	7.5	3.0	4.5	40.9			
160	11.7	2.2	2.3	-0.2	-1.4	15.6	2.9	3.2	-0.3	-2.4	26.2	6.0	3.0	3.0	28.6	31.5	7.2	3.0	4.2	40.0			
170	11.1	2.1	2.3	-0.3	-2.6	14.8	2.8	3.2	-0.4	-3.9	25.0	5.7	3.0	2.7	27.5	30.0	6.8	3.0	3.8	39.1			
180	10.6	2.0	2.3	-0.3	-3.7	14.2	2.6	3.2	-0.5	-5.5	23.9	5.4	3.0	2.4	26.4	28.7	6.5	3.0	3.5	38.1			
190	10.2	1.9	2.3	-0.4	-4.8	13.6	2.5	3.2	-0.6	-7.0	22.9	5.2	3.0	2.2	25.2	27.5	6.3	3.0	3.3	37.1			
200	9.8	1.8	2.3	-0.5	-6.0	13.0	2.4	3.2	-0.7	-8.6	22.0	5.0	3.0	2.0	24.1	26.4	6.0	3.0	3.0	36.1			
Max =					<b>9.3</b>						<b>12.4</b>						<b>35.0</b>						<b>44.6</b>
<b>Notes</b>											<b>City of Ottawa IDF Data (from SDG002)</b>												
1) Peak flow is equal to the product of 2.78 x C x I x A 2) Rainfall Intensity, I = A/(T <sub>c</sub> +C) <sup>B</sup> 3) Release Rate = Min (Release Rate, Peak Flow) 4) Storage Rate = Peak Flow - Release Rate 5) Storage = Duration x Storage Rate 6) Maximum Storage = Max Storage Over Duration 7) Parameters a,b,c are for City of Ottawa											<b>IDF curve equations (Intensity in mm/hr)</b> 100 year Intensity = 1735.688 / (Time in min + 6.014) <sup>0.820</sup> 50 year Intensity = 1569.580 / (Time in min + 6.014) <sup>0.820</sup> 25 year Intensity = 1402.884 / (Time in min + 6.018) <sup>0.819</sup> 10 year Intensity = 1174.184 / (Time in min + 6.014) <sup>0.816</sup> 5 year Intensity = 998.071 / (Time in min + 6.053) <sup>0.814</sup> 2 year Intensity = 732.951 / (Time in min + 6.199) <sup>0.810</sup>												

**TABLE A20 Storage Volumes for 2-year, 5-Year and 100-Year Storms (MRM) (241 Beechwood Ave.)**

Area No: <b>S01, S02</b> $C_{AVG} = \frac{0.78}{(2\text{-yr})}$ $C_{AVG} = \frac{0.78}{(5\text{-yr})}$ $C_{AVG} = \frac{0.98}{(100\text{-yr, Max 1.0})}$ Time Interval = <u>10.00</u> (mins) Drainage Area = <u>0.0821</u> (hectares)																							
Actual Release Rate (L/sec) = <u>6.00</u> Percentage of Actual Rate (City of Ottawa requirement) = <u>50%</u> (Set to 50% when U/G storage used) Release Rate Used for Estimation of 100-year Storage (L/sec) = <u>3.00</u>											Intensity Incr (%) = <u>20%</u> Use 20% for Climate Change												
Duration (mins)	Release Rate = <u>2.32</u> (L/sec) Return Period = <u>2</u> (years) IDF Parameters, A = <u>733.0</u> , B = <u>0.810</u> (I = A/(T <sub>c</sub> +C), C = <u>6.199</u> )					Release Rate = <u>3.15</u> (L/sec) Return Period = <u>5</u> (years) IDF Parameters, A = <u>998.1</u> , B = <u>0.814</u> (I = A/(T <sub>c</sub> +C), C = <u>6.053</u> )					Release Rate = <u>3.00</u> (L/sec) Return Period = <u>100</u> (years) IDF Parameters, A = <u>1735.7</u> , B = <u>0.820</u> (I = A/(T <sub>c</sub> +C), C = <u>6.014</u> )					Release Rate = <u>3.00</u> (L/sec) Return Period = <u>100+20%</u> (years) IDF Parameters, A = <u>1735.7</u> , B = <u>0.820</u> (I = A/(T <sub>c</sub> +C), C = <u>6.014</u> )							
	Rainfall Intensity, I (mm/hr)	Peak Flow (L/sec)	Release Rate (L/sec)	Storage Rate (L/sec)	Storage (m <sup>3</sup> )	Rainfall Intensity, I (mm/hr)	Peak Flow (L/sec)	Release Rate (L/sec)	Storage Rate (L/sec)	Storage (m <sup>3</sup> )	Rainfall Intensity, I (mm/hr)	Peak Flow (L/sec)	Release Rate (L/sec)	Storage Rate (L/sec)	Storage (m <sup>3</sup> )	Rainfall Intensity, I (mm/hr)	Peak Flow (L/sec)	Release Rate (L/sec)	Storage Rate (L/sec)	Storage (m <sup>3</sup> )			
0	167.2	29.9	2.3	27.6	0.0	230.5	41.2	3.2	38.1	0.0	398.6	89.1	3.0	86.1	0.0	478.3	106.9	3.0	103.9	0.0			
10	76.8	13.7	2.3	11.4	6.8	104.2	18.6	3.2	15.5	9.3	178.6	39.9	3.0	36.9	22.1	214.3	47.9	3.0	44.9	26.9			
20	52.0	9.3	2.3	7.0	8.4	70.3	12.6	3.2	9.4	11.3	120.0	26.8	3.0	23.8	28.6	143.9	32.2	3.0	29.2	35.0			
30	40.0	7.2	2.3	4.8	8.7	53.9	9.6	3.2	6.5	11.7	91.9	20.5	3.0	17.5	31.6	110.2	24.6	3.0	21.6	39.0			
40	32.9	5.9	2.3	3.6	8.5	44.2	7.9	3.2	4.8	11.4	75.1	16.8	3.0	13.8	33.1	90.2	20.2	3.0	17.2	41.2			
50	28.0	5.0	2.3	2.7	8.1	37.7	6.7	3.2	3.6	10.7	64.0	14.3	3.0	11.3	33.9	76.7	17.2	3.0	14.2	42.5			
60	24.6	4.4	2.3	2.1	7.4	32.9	5.9	3.2	2.7	9.9	55.9	12.5	3.0	9.5	34.2	67.1	15.0	3.0	12.0	43.2			
70	21.9	3.9	2.3	1.6	6.7	29.4	5.3	3.2	2.1	8.8	49.8	11.1	3.0	8.1	34.1	59.7	13.4	3.0	10.4	43.5			
80	19.8	3.5	2.3	1.2	5.9	26.6	4.8	3.2	1.6	7.7	45.0	10.1	3.0	7.1	33.9	54.0	12.1	3.0	9.1	43.5			
90	18.1	3.2	2.3	0.9	5.0	24.3	4.3	3.2	1.2	6.4	41.1	9.2	3.0	6.2	33.4	49.3	11.0	3.0	8.0	43.4			
100	16.7	3.0	2.3	0.7	4.0	22.4	4.0	3.2	0.9	5.1	37.9	8.5	3.0	5.5	32.8	45.5	10.2	3.0	7.2	43.0			
110	15.6	2.8	2.3	0.5	3.0	20.8	3.7	3.2	0.6	3.8	35.2	7.9	3.0	4.9	32.1	42.2	9.4	3.0	6.4	42.5			
120	14.6	2.6	2.3	0.3	2.0	19.5	3.5	3.2	0.3	2.4	32.9	7.4	3.0	4.4	31.3	39.5	8.8	3.0	5.8	41.9			
130	13.7	2.4	2.3	0.1	1.0	18.3	3.3	3.2	0.1	0.9	30.9	6.9	3.0	3.9	30.5	37.1	8.3	3.0	5.3	41.3			
140	12.9	2.3	2.3	0.0	-0.1	17.3	3.1	3.2	-0.1	-0.5	29.2	6.5	3.0	3.5	29.5	35.0	7.8	3.0	4.8	40.5			
150	12.3	2.2	2.3	-0.1	-1.2	16.4	2.9	3.2	-0.2	-2.0	27.6	6.2	3.0	3.2	28.6	33.1	7.4	3.0	4.4	39.7			
160	11.7	2.1	2.3	-0.2	-2.3	15.6	2.8	3.2	-0.4	-3.5	26.2	5.9	3.0	2.9	27.5	31.5	7.0	3.0	4.0	38.8			
170	11.1	2.0	2.3	-0.3	-3.4	14.8	2.7	3.2	-0.5	-5.1	25.0	5.6	3.0	2.6	26.4	30.0	6.7	3.0	3.7	37.8			
180	10.6	1.9	2.3	-0.4	-4.6	14.2	2.5	3.2	-0.6	-6.6	23.9	5.3	3.0	2.3	25.3	28.7	6.4	3.0	3.4	36.8			
190	10.2	1.8	2.3	-0.5	-5.7	13.6	2.4	3.2	-0.7	-8.2	22.9	5.1	3.0	2.1	24.2	27.5	6.1	3.0	3.1	35.8			
200	9.8	1.7	2.3	-0.6	-6.9	13.0	2.3	3.2	-0.8	-9.8	22.0	4.9	3.0	1.9	23.0	26.4	5.9	3.0	2.9	34.8			
Max =					<b>8.7</b>						<b>11.7</b>						<b>34.2</b>						<b>43.5</b>
<b>Notes</b> 1) Peak flow is equal to the product of 2.78 x C x I x A 2) Rainfall Intensity, I = A/(T <sub>c</sub> +C) <sup>B</sup> 3) Release Rate = Min (Release Rate, Peak Flow) 4) Storage Rate = Peak Flow - Release Rate 5) Storage = Duration x Storage Rate 6) Maximum Storage = Max Storage Over Duration 7) Parameters a,b,c are for City of Ottawa											<b>City of Ottawa IDF Data (from SDG002)</b> <b>IDF curve equations (Intensity in mm/hr)</b> 100 year Intensity = 1735.688 / (Time in min + 6.014) <sup>0.820</sup> 50 year Intensity = 1569.580 / (Time in min + 6.014) <sup>0.820</sup> 25 year Intensity = 1402.884 / (Time in min + 6.018) <sup>0.819</sup> 10 year Intensity = 1174.184 / (Time in min + 6.014) <sup>0.816</sup> 5 year Intensity = 998.071 / (Time in min + 6.053) <sup>0.814</sup> 2 year Intensity = 732.951 / (Time in min + 6.199) <sup>0.810</sup>												

**Table A21: 5-year & 100-year Roof Design Sheet - For Roof Drains using Flow Controlled Roof Drains (229 Beechwood)**

Project: 229-241 Beechwood Avenue  
 Location: City of Ottawa  
 Date: March 2022

Area #	Drain Type	Roof Drain Type	No Drains per Area	No of Weirs per Drain	Weir Position	Runoff Coeff (Cavg)		Drainage Area		5-year Event						100-year Event						Storage Required (ARM)		Maximum Storage Provided at Spill Elevation				
						5-year	100-year	m <sup>2</sup>	ha	Runoff Rate (L/sec)	5yr Ponding Depth (mm)	Roof Drain Capacity Per Weir (gpm)	Roof Drain Capacity Per Drain per weir (gpm)	Roof Drain Capacity Per Drain (L/sec)	Total Flow From Roof Drains (L/sec)	Runoff Rate (L/sec)	100yr Ponding Depth (mm)	Roof Drain Capacity Per Weir (gpm)	Roof Drain Capacity Per Drain per weir (gpm)	Roof Drain Capacity Per Drain (L/sec)	Total Flow From Roof Drains (L/sec)	5-year (m <sup>3</sup> )	100-year (m <sup>3</sup> )	Area Available for Storage (m <sup>2</sup> )	Max Prism Depth (mm)	Max Prism Volume (m <sup>3</sup> )	Total Volume (m <sup>3</sup> )	
S04 1	RD	RD1	2	1	6-Full	0.90	0.90	132.3	0.0132	3.449	87	17.4	17.4	1.098	2.196	5.911	110	22.0	22.0	1.388	2.776	0.79	1.88	132.3	150	6.6	6.62	
S04 2	RD	RD1	1	1	6-Full	0.90	0.90	56.5	0.0057	1.473	75	15.0	15.0	0.946	0.946	2.524	98	19.6	19.6	1.237	1.237	0.33	0.77	56.5	150	2.8	2.83	
S04 3	RD	RD1	1	1	3-1/4 open	0.90	0.90	33.2	0.0033	0.865	67	10.9	10.9	0.685	0.685	1.483	95	12.3	12.3	0.773	0.773	0.15	0.43	33.2	150	1.7	1.66	
S04 4	RD	RD1	1	1	4-1/2 open	0.90	0.90	151.0	0.0151	3.936	98	14.8	14.8	0.933	0.933	6.746	125	17.5	17.5	1.104	1.104	2.07	4.23	151.0	150	7.6	7.55	
S04 5	RD	RD1	1	1	3-1/4 open	0.90	0.90	93.9	0.0094	2.448	93	12.2	12.2	0.767	0.767	4.195	120	13.5	13.5	0.852	0.852	1.08	2.38	93.9	150	4.7	4.70	
S04 6	RD	RD2	1	no weir	1-None	0.90	0.90	31.7	0.0032	0.826	0	13.1	13.1	0.826	0.826	1.416	0	22.4	22.4	1.416	1.416			0.0	0	0.0	0.00	
S04 7	RD	RD2	1	no weir	1-None	0.90	0.90	10.1	0.0010	0.263	0	4.2	4.2	0.263	0.263	0.451	0	7.2	7.2	0.451	0.451			0.0	0	0.0	0.00	
S04 8	RD	RD2	1	no weir	1-None	0.90	0.90	12.9	0.0013	0.336	0	5.3	5.3	0.336	0.336	0.576	0	9.1	9.1	0.576	0.576			0.0	0	0.0	0.00	
S04 9	RD	RD2	1	no weir	1-None	0.90	0.90	19.5	0.0020	0.508	0	8.1	8.1	0.508	0.508	0.871	0	13.8	13.8	0.871	0.871			0.0	0	0.0	0.00	
S04 10	RD	RD2	1	no weir	1-None	0.90	0.90	13.8	0.0014	0.360	0	5.7	5.7	0.360	0.360	0.617	0	9.8	9.8	0.617	0.617			0.0	0	0.0	0.00	
S04 11	RD	RD2	1	no weir	1-None	0.90	0.90	16.8	0.0017	0.438	0	6.9	6.9	0.438	0.438	0.751	0	11.9	11.9	0.751	0.751			0.0	0	0.0	0.00	
S04 12	RD	RD2	1	no weir	1-None	0.90	0.90	32.2	0.0032	0.839	0	13.3	13.3	0.839	0.839	1.439	0	22.8	22.8	1.439	1.439			0.0	0	0.0	0.00	
<b>Totals</b>						0.9	0.9	<b>604</b>	<b>0.0604</b>	<b>15.743</b>		<b>126.80</b>		<b>8.00</b>	<b>9.10</b>	<b>26.98</b>		<b>181.86</b>		<b>11.47</b>	<b>12.86</b>	<b>4.42</b>	<b>9.69</b>	<b>467</b>		<b>23.3</b>	<b>23.3</b>	
<b>Min</b>																												
<b>Max</b>																												

**Runoff Based on the Following:**

Storm Frequency (years) = 5 100  
 Time of Conc (mins) = 10 10  
 Storm Intensity (mm/hr) = 104.2 178.6

Qyr(cont) = 6.8  
 V2yr = 3.3

**Roof Drains have Following Flow Rates: WATTS Flow Controlled Drain**

Weir Position	Flow (gpm) per depth							Max Flow Rate per Weir
	0	25	50	75	100	125	150	
1-None	0	0	0	0	0	0	0	0.000
2-Closed	0	5	5	5	5	5	5	0.315
3-1/4 open	0	5	10	11	13	14	15	0.946
4-1/2 open	0	5	10	12	15	18	20	1.262
5-3/4 open	0	5	10	14	18	21	25	1.577
6-Full	0	5	10	15	20	25	30	1.893

**Roof Drain Types**

Drain Type = RD1 RD2  
 Max Overflow Depth (mm) 150 mm 150 mm  
 Flow Controlled (Yes/No) Yes No  
 Ponding Yes No  
 Weir Desc Accutrol n/a  
 No. Weirs 1 n/a

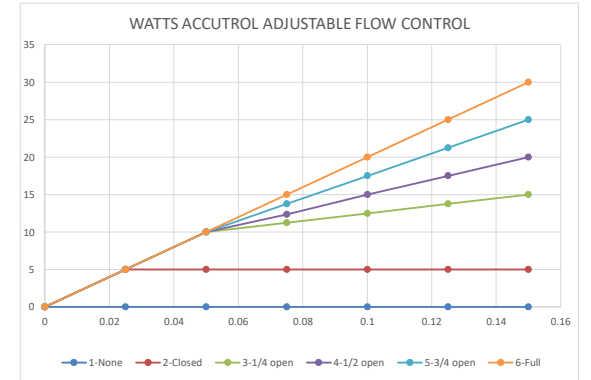

**Table A22: 5-year & 100-year Roof Design Sheet - For Roof Drains using Flow Controlled Roof Drains (241 Beechwood)**

Project: 229-241 Beechwood Avenue  
 Location: City of Ottawa  
 Date: March 2022

Area #	Drain Type	Roof Drain Type	No Drains per Area	No of Weirs per Drain	Weir Position	Runoff Coeff (Cavg)		Drainage Area		5-year Event						100-year Event						Storage Required (MRM)		Maximum Storage Provided at Spill Elevation			
						5-year	100-year	m <sup>2</sup>	ha	Runoff Rate (L/sec)	5yr Ponding Depth (mm)	Roof Drain Capacity Per Weir (gpm)	Roof Drain Capacity Per Drain (gpm)	Roof Drain Capacity Per Drain (L/sec)	Total Flow From Roof Drains (L/sec)	Runoff Rate (L/sec)	100yr Ponding Depth (mm)	Roof Drain Capacity Per Weir (gpm)	Roof Drain Capacity Per Drain (gpm)	Roof Drain Capacity Per Drain (L/sec)	Total Flow From Roof Drains (L/sec)	5-year (m <sup>3</sup> )	100-year (m <sup>3</sup> )	Area Available for Storage (m <sup>2</sup> )	Max Prism Depth (mm)	Max Prism Volume (m <sup>3</sup> )	Total Volume (m <sup>3</sup> )
S01_1	RD	RD1	1	1	6-Full	0.90	0.90	120.1	0.0120	3.131	89	17.8	17.8	1.123	1.123	5.366	113	22.6	22.6	1.426	1.426	1.24	2.61	120.1	150	6.0	6.01
S01_2	RD	RD1	1	1	6-Full	0.90	0.90	31.9	0.0032	0.832	65	13.0	13.0	0.820	0.820	1.425	82	16.4	16.4	1.035	1.035	0.08	0.28	31.9	150	1.6	1.60
S01_3	RD	RD1	1	1	3-1/4 open	0.90	0.90	122.3	0.0122	3.188	97	12.4	12.4	0.779	0.779	5.464	124	13.7	13.7	0.864	0.864	1.65	3.50	122.3	150	6.1	6.12
S01_4	RD	RD1	1	1	4-1/2 open	0.90	0.90	62.8	0.0063	1.637	80	12.9	12.9	0.813	0.813	2.806	107	15.7	15.7	0.991	0.991	0.49	1.12	62.8	150	3.1	3.14
S01_5	RD	RD1	1	1	3-1/4 open	0.90	0.90	89.8	0.0090	2.341	92	12.1	12.1	0.763	0.763	4.012	119	13.5	13.5	0.849	0.849	1.00	2.22	89.8	150	4.5	4.49
S01_6	RD	RD2	1	no weir	1-None	0.90	0.90	10.3	0.0010	0.269	0	4.3	4.3	0.269	0.269	0.460	0	7.3	7.3	0.460	0.460			0.0	0	0.0	0.00
S01_7	RD	RD2	1	no weir	1-None	0.90	0.90	22.7	0.0023	0.592	0	9.4	9.4	0.592	0.592	1.014	0	16.1	16.1	1.014	1.014			0.0	0	0.0	0.00
S01_8	RD	RD2	1	no weir	1-None	0.90	0.90	20.8	0.0021	0.542	0	8.6	8.6	0.542	0.542	0.929	0	14.7	14.7	0.929	0.929			0.0	0	0.0	0.00
S01_9	RD	RD2	1	no weir	1-None	0.90	0.90	25.6	0.0026	0.667	0	10.6	10.6	0.667	0.667	1.144	0	18.1	18.1	1.144	1.144			0.0	0	0.0	0.00
S01_10	RD	RD2	1	no weir	1-None	0.90	0.90	53.4	0.0053	1.392	0	22.1	22.1	1.392	1.392	2.386	0	37.8	37.8	2.386	2.386			0.0	0	0.0	0.00
S01_11	RD	RD2	1	no weir	1-None	0.90	0.90	23.0	0.0023	0.600	0	9.5	9.5	0.600	0.600	1.028	0	16.3	16.3	1.028	1.028			0.0	0	0.0	0.00
<b>Totals</b>						0.9	0.9	<b>583</b>	<b>0.0583</b>	15.190		<b>132.51</b>		<b>8.36</b>		<b>26.03</b>		<b>192.18</b>		<b>12.12</b>	<b>12.12</b>	<b>4.47</b>	<b>9.74</b>	<b>427</b>		<b>21.3</b>	<b>21.3</b>
<b>Min</b>											<b>0</b>																
<b>Max</b>																											

**Runoff Based on the Following:**

Storm Frequency (years) = 5 100  
 Time of Conc (mins) = 10 10  
 Storm Intensity (mm/hr) = 104.2 178.6

Qyr(cont) = 6.3  
 V2yr = 3.3

**Roof Drain Types**

Drain Type = RD1 RD2  
 Max Overflow Depth (mm) 150 mm 150 mm  
 Flow Controlled (Yes/No) Yes No  
 Ponding Yes No  
 Weir Desc Accutrol n/a  
 No. Weirs 1 n/a

**Roof Drains have Following Flow Rates: WATTS Flow Controlled Drain**

Weir Position	Flow (gpm) per depth							Max Flow Rate per Weir
	0	25	50	75	100	125	150	
1-None	0	0	0	0	0	0	0	0.000
2-Closed	0	5	5	5	5	5	5	0.315
3-1/4 open	0	5	10	11	13	14	15	0.946
4-1/2 open	0	5	10	12	15	18	20	1.262
5-3/4 open	0	5	10	14	18	21	25	1.577
6-Full	0	5	10	15	20	25	30	1.893

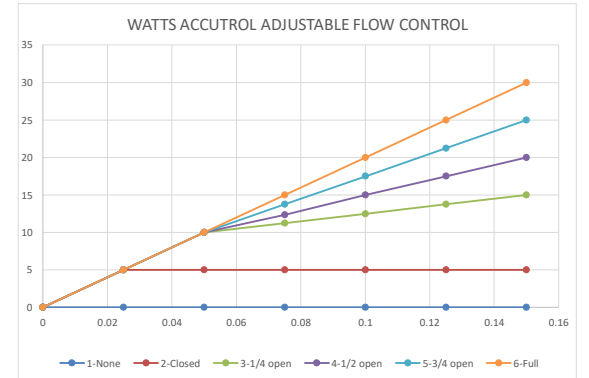



## **Appendix B – Consultation / Correspondence**

**Email from City of Ottawa on Water System Boundary Conditions**

## **Engineering Comments**

### **Infrastructure:**

- A 254 mm dia. UCI Watermain (c. 19??) is available.
- A 300 mm dia. Conc. Sanitary Sewer (c. 1933) is available, which drains to Rideau River Trunk/Collector Sewer and onto the Interceptor Sewer.
- A 1200 dia. mm Conc. Storm Sewer (c. 1973) is available, which drains to the Vanier Storm on Jolliet Avenue and Outlets to the Ottawa River near Hillsdale Rd.

Note: New infrastructure was completed on Jolliet Avenue in 2015-2017, although not directly connected to Beechwood Avenue.

The following apply to this site and any development within a separated sewer area:

- Total (San & Stm) allowable release rate will be 2-year pre-development rate
- This site is on a **local road** and within a partially **separated sewer** area and infrastructure is dated.
- Coefficient (C) of runoff will need to be determined **as per existing conditions** but in no case more than 0.5
- TC = 20 minutes or can be calculated  
TC should be not be less than 10 minutes, since IDF curves become unrealistic at less than 10 min.
- Any storm events greater than 5 year, up to 100 year, and including 100-year storm event must be detained on site.
- Two separate sewer laterals (one for sanitary and other for storm) will be required.

### **Please note:**

- Foundation drains are to be independently connected to sewermain (separated or combined) unless being pumped with appropriate back up power, sufficient sized pump and back flow prevention.
- Roof drains are to be connected downstream of any incorporated ICD within the SWM system.
- Boundary Conditions will be provided at request of consultant after providing Average Daily Demands, Peak Hour Demands & Max Day + Fire Flow Demands
- Existing buildings require a CCTV inspection and report to ensure existing services to be re-used are in good working order and meet current minimum size requirements. Located services to be placed on site servicing plans.



CCTV Scan  
Guideline.pdf

### **Other:**

Environmental Noise Study is required due to site being on Beechwood Avenue.

Water Supply Redundancy – Fire Flow:

Applicant to ensure that a second service with an inline valve chamber be provided where the average daily demand exceeds 50 m<sup>3</sup> / day (0.5787 l/s per day)  
FUS Fire Flow Criteria to be used unless a low-rise building, where OBC requirements may be applicable.

Source Protection Policy Screening (SPPS):

1. The addresses lie within the Mississippi-Rideau Source Protection Region and are subject to the policies of the Mississippi-Rideau Source Protection Plan.
  2. The area is not located within a Surface Water Intake Protection Zone (IPZ) where significant threat policies apply.
  3. The area is not located within a Wellhead Protection Area (WHPA).
  4. The area is not within a Significant Groundwater Recharge Area.
  5. The area is not within a Highly Vulnerable Aquifer.
- In terms of the Planning Act application, please note that the addresses are not located in an area where activities could be considered a significant threat to drinking water sources and there are no legally-binding source protection policies.
  - Applicant to contact Rideau Valley Conservation Authority (RVCA) for possible restrictions due to quality control. Provide correspondence in Report.
  - Where underground storage (UG) and surface ponding are being considered:
    - Show all ponding for 5- and 100-year events
    - Above and below ground storage is permitted although uses ½ Peak Flow Rate or is modeled. Please confirm that this has been accounted for and/or revise.

Rationale:

The Modified Rational Method for storage computation in the Sewer Design Guidelines was originally intended to be used for above ground storage (i.e. parking lot) where the change in head over the orifice varied from 1.5 m to 1.2 m (assuming a 1.2 m deep CB and a max ponding depth of 0.3 m). This change in head was small and hence the release rate fluctuated little, therefore there was no need to use an average release rate.

When underground storage is used, the release rate fluctuates from a maximum peak flow based on maximum head down to a release rate of zero. This difference is large and has a significant impact on storage requirements. We therefore require that an average release rate be used to estimate the required volume. Alternatively, the consultant may choose to use a submersible pump in the design to ensure a constant release rate.

In the event that there is a disagreement from the designer regarding the required storage, The City will require that the designer demonstrate their rationale utilizing dynamic modelling, that will then be reviewed by City modellers in the Water Resources Group.

Note that the above will be added to upcoming revised Sewer Design Guidelines to account for underground storage, which is now widely used.

Further to above, what will be the actual underground storage provided during the major (100 year) and minor (2 year) storm events?

Please provide information on UG storage pipe. Provide required cover over pipe and details, chart of storage values, capacity etc. How will this pipe be cleaned of sediment and debris?

Note - There must be at least 15cm of vertical clearance between the spill elevation and the ground elevation at the building envelope that is in proximity of the flow route or ponding area. The exception in this case would be at reverse sloped loading dock locations. At these locations, a minimum of 15cm of vertical clearance must be provided below loading dock openings. Ensure to provide discussion in report and ensure grading plan matches if applicable.

Provide information on type of underground storage system including product name and model, number of chambers, chamber configuration, confirm invert of chamber system, top of chamber system, required cover over system and details, interior bottom slope (for self-cleansing), chart of storage values, length, width and height, capacity, entry ports (maintenance) etc.

Provide a cross section of underground chamber system showing invert and obvert/top, major and minor HWLs, top of ground, system volume provided during major and minor events. UG storage to provide actual 2- and 100-year event storage requirements.

In regard to all proposed UG storage, ground water levels (and in particular HGW levels) will need to be reviewed to ensure that the proposed system does not become surcharged and thereby ineffective.

Modeling can be provided to ensure capacity for both storm and sanitary sewers for the proposed development by City's Water Distribution Dept. – Modeling Group, through PM and upon request.

For proposed depressed driveways or developments with private lanes, parking areas or with entrances etc. lower than roadway.



S18.pdf



S18.1.pdf

Provided Info:

Please be advised that it is the responsibility of the applicant and their representatives/consultants to verify information provided by the City of Ottawa. Please contact City View and Release Info Centre at Ext. 44455

### **Environmental Source Information:**

City of Ottawa - Historical Land Use Inventory (HLUI) - Required

Rationale:

The HLUI database is currently undergoing an update. The updated HLUI will include additional sources beyond those included in the current database, making the inclusion of this record search even more important.

Although a municipal historic land use database is not specifically listed as required environmental record in O. Reg 153/04, Schedule D, Part II states the following:

The following are the specific objectives of a records review:

1. To obtain and review records that relate to the Phase I (One) property and to the current and past uses of and activities at or affecting the Phase I (One) property in order to determine if an area of potential environmental concern exists and to interpret any area of potential environmental concern.
2. To obtain and review records that relate to properties in the Phase I (One) study area other than the Phase I (One) property, in order to determine if an area of potential environmental concern exists and to interpret any area of potential environmental concern.

It is therefore reasonable to request that the HLUI search be included in the Phase I ESA to meet the above objectives.

Please submit.

- All existing reports and plans will need to be revised if older than 2 years and must reflect current City Standards, Guidelines, By-laws and Policies.
- Please refer to City of Ottawa website portal for **“Guide to preparing Studies and Plans”** at <https://ottawa.ca/en/city-hall/planning-and-development/information-developers/development-application-review-process/development-application-submission/guide-preparing-studies-and-plans>.
- Please ensure you are using the current guidelines, bylaws and standards including materials of construction, disinfection and all relevant reference to OPSS/D and AWWA guidelines - all current and as amended, such as:
- City of Ottawa Sewer Design Guidelines (CoOSDG) complete with ISTDB 2012-01, 2014-01, 2016-01, 2018-01 & 2019-02 technical bulletin updates as well as current Sewer, Landscape & Road Standard Detail Drawings as well as Material Specifications (MS Docs).  
Sewer Connection (2003-513) & Sewer Use (2003-514) By-Laws.
- City of Ottawa Water Distribution Design Guidelines (CoOWDDG) complete with ISTDB 2010-02, 2014-02 & 2018-02 technical bulletin updates as well as current Watermain/ Services Material Specifications (MS Docs) as well as Water and Road Standard Detail Drawings.  
FUS Fire Flow standards  
Water (2018-167) By-Law
- Ensure to include version date and add **“(as amended)”** when referencing all standards, detail drawings, by-Laws and guidelines.
- Please contact me by e-mail [shawn.wessel@ottawa.ca](mailto:shawn.wessel@ottawa.ca) if you have any questions.
- Please also note that in the event soil and/or groundwater contamination is identified on this site and the proposal is for a more sensitive land use, the MECP will require approximately 1-1.5 years to review the RSC.
- PIED will apply appropriate conditions, based on Environmental Protection Act (Section 168.3.1 (1)) and O.Reg. 153/04 (Parts IV and V) regarding requirements for RSC prior to building permit issuance. Dependent on the levels/types of contamination, timelines for building permit issuance may be longer than expected and we recommend applicant speak to Building Code Services, at the earliest convenience, so as to discuss these timelines in more detail, if deemed applicable.

## Pre-Application Consultation Meeting Notes

Property Address: 229 – 247 Beechwood Avenue  
PC2020-0099  
May 5, 2020 via teleconference

---

### Attendees:

Simon Deiaco, city of Ottawa  
Shawn Wessel, City of Ottawa  
Christopher Moise, City of Ottawa  
Neeti Paudel, City of Ottawa  
Mackenzie Kimm, City of Ottawa  
Jeremy Silburt, Smart Living Properties  
Bod Woodman, Architect  
Tino Tolot, Architect  
Chris Greenshields, VCA  
Lauren Touchant, VCA  
Peter Lewis, Rockcliffe Park RA

---

**Subject: 229-247 Beechwood Avenue**

### Meeting notes:

Opening & attendee introduction

- Introduction of meeting attendees
- **Overview of proposal: (Bob Woodman, Tino Tolot and Jeremy Silburt)**
  - The existing buildings would be removed. Proposing two new low-rise apartments, with no tenant parking. The building at 229 Beechwood would contain 48 units, with 55 units proposed for 241 Beechwood. There would be a mix of bachelor, one and two-bedroom units in each building.
  - The buildings are three storeys above grade and are proposed to be within the maximum height permitted (12.5m).
  - Property slopes to the north and is more significant to the east as shown in the difference in the grades to the proposed entrances. The building at 229 Beechwood has less slope to accommodate, therefore units can enter from grade.
  - Garbage sheds will be located in the rear within an enclosure. Bike parking would be accommodated at 241 Rideau for both buildings.
  - Considering new building features that will allow walls to be moved within the apartment.
  - Rooftop and rear yard amenity spaces are proposed for each building.

Preliminary comments and questions from staff and agencies, including follow-up actions:

- **Planning (Simon Deiaco)**

- Proposed application requires an application for Site Plan Control (complex) and potential variances.
  - Site is fronting a long a Traditional Mainstreet (TM), and zoned R4M[1321] which permits the proposed use (low-rise apartment) with a maximum height of 12.5 metres. The site is located along area Y with respect to required parking.
  - Exception 1321 outlines additional site specific zoning (see below).
  - Visitor parking requirements have not been calculated or demonstrated.
  - Due to the grade of the site a survey plan and proper calculation of height needs to be completed early in the design process.
  - The property is within the Rockcliffe Park Heritage District and will require approvals under the *Ontario Heritage Act*.
  - Site is designated as “Residential – Multiple Family” in the Rockcliffe Secondary Plan.
  - Beechwood Avenue will be considered the frontage for both sites for the purpose of determining yards, Section 197, sub 5.
  - Located within a design priority area, therefore the project will be subject to UDRP consultation and review.
  - Bike parking is to be provided within each building as per the by-law requirements. Staff do not support the proposed arrangement of all bike parking in one building.
- **Urban Design (Christopher Moise)**
    - Staff recommend the proposal attend a visit with the City’s UDRP to further discuss and evaluate various scenarios of development for the site. In preparation to that visit, we recommend that the following comments are considered and responded to:
      - Please indicate the material choices for the elevations. Note: Compatibility of materials in this neighbourhood is important and should be considered, especially on the street facing facades;
      - Have grade related units been considered to help integrate such a long street facade?
      - The streetscape should be designed to relate better with the scale and density of the proposal (ie. pedestrian access and mobility similar to nearby projects as across the street), and not a single entrance and front lawn which is more traditionally seen with single family detached dwellings;
      - Due to the sloping grades on the site staff question whether the westerly side yard might be increased to 2.5m (as on the easterly side yard) to respect the shift in heights from the neighbouring property and this one;
      - We also note that the requirement to further set-back the side-yard to 6m at 21m from the front lot line is being employed. This is one of the changes staff are contemplating removing from R4 zones and suggest that the aforementioned increase of the entire westerly side yard set-back to 2.5m will satisfy the intent of this requirement.



- **Engineering (Shawn Wessel)**
  - Please see separate attachment.
- **Transportation (Neeti Paudel)**
  - TIA will be required
  - MMLOS analysis will be required as part of the TIA.
  - Sidewalk needs to be upgraded along the frontage of the properties (2.0m concrete sidewalk).
  - Question: Will Carsdale be the access for waste collection? Yes, that is the plan (JS). Need a hammerhead to provide for vehicle turn around and show on a turning template.
  - Please show 23.0m right of way protection limits need to be shown along the site frontage.
  - Follow Traffic Impact Assessment Guidelines
    - Traffic Impact Assessment will be required.
    - Beechwood is a spine cycling route and triggers the location trigger on the TIA.
    - Applicant advised that their application will not be deemed complete until the submission of the draft step 1-4, including the functional draft RMA package (if applicable) and/or monitoring report (if applicable).
  - ROW protection on Beechwood between Marier and Joliet is 23m even. Ensure this is shown on the site plan.
  - Site triangles at the following locations on the final plan will be required:
    - Arterial Road to Local Road: 5 metre x 5 metres
  - Upgrade the sidewalk as per City standards. The existing is a substandard asphalt sidewalk.
  - A cul de sac in the form of hammerhead would be required on Carsdale Avenue for vehicle turnaround. Provide a turning template to show the largest vehicle making the turn.
  - The bus stop on the site frontage on Beechwood may have to be upgraded. OC Transpo will be reviewing this at site plan.
  - On site plan:
    - Show all details of the roads abutting the site up to and including the opposite curb; include such items as pavement markings, accesses and/or sidewalks.
    - Show lane/aisle widths.
- **Environmental (Simon Deiac)**
  - A TCR will be required as part of the application. Early consideration into the management of trees should be considered. The team should clearly identify what trees are on public versus private property.
- **Parks (Simon Deiac)**
  - Cash-in-lieu of parkland will be required as part of the approval.

- **Heritage (MacKenzie Kimm)**
  - The project requires a heritage permit for demolition and new construction. This will be a full permit through the Built Heritage Subcommittee, Planning Committee and City Council.
  - There is new fee as part of the process - \$5,100 for new construction in the HCD. This will be required as part of the complete application.
  - Submission requirements will be forwarded following the heritage pre-consult meeting.
  - A new heritage consultation process is in place and will require a separate meeting with staff, the applicant and the RPRA Heritage Committee.
  - A Cultural Heritage Impact Statement (CHIS) will be required as part of the heritage and SPC submission. Please refer to the [Guide to preparing cultural heritage impact statements](#) available on the City's website.
  - Staff strongly recommend bringing a heritage consultant on board as early in the process as possible, in order provide guidance on the design in the context of the HCD.
  - Staff notes that this proposal would be a departure the existing built form and the current lot fabric. The existing buildings are Category 2 buildings (non-contributing), but the plan does encourage the retention of buildings. This will have to be justified in the CHIS. Measures to mitigate any negative impacts of the new buildings will also need to be included in the CHIS.
  - Staff will provide specific comments on the proposal as part of the separate pre-consultation pilot process. However, it is recommended that the applicant carefully review the Rockcliffe Park HCD plan policies and guidelines prior to the meeting.
  - Of particular note, the HCD plan includes specific direction regarding lot division/consolidation, landscaping (7.3.3 and 7.4.3) and the design of new construction, including:
    - Ensuring the retention of existing lots and general lot sizes in the HCD
    - The location of new buildings on lots;
    - Ensuring new construction contributes to, and does not detract from the HCD and its attributes, particularly the surrounding buildings within the streetscape;
    - Maintaining existing grades and the dominance of soft landscaping
  - Staff note that the design of any new construction on these lots will be critical to determining the appropriateness of the proposal, and whether it can meet the policies and guidelines of the Rockcliffe HCD Plan.
  - Additionally, the HCD plan provides guidelines for the conservation of the public realm, including the retention of the block and street pattern, road widths, and the informal nature of the road edges (no sidewalks). Further information would be required to determine if acquiring part of Carsdale would be appropriate within the HCD plan context.

- **Questions and comments from the Community Association representatives**

- Rockcliffe Park Residents Association (Peter Lewis)**

- Agrees with the comments of the Heritage Planner.
    - The fact that Rockcliffe Park is a Heritage Conservation Area comprised entirely of single-family units will be a major point of resistance to a multi family building - regardless of the zoning.
    - More generally, and this is not restricted to Rockcliffe, we as a larger community - including Lindenlea, Vanier, and New Edinburgh are very concerned by the proliferation of studio and one bedroom apartments in what are essentially family areas.
    - Location map needs to be revised. Noted by applicant.
    - Question to staff - Is there a maximum number of units within the existing R4 zoning. SD – not applicable in this zone, no dwelling unit cap.

- Vanier Community Association (Chris Greenshields)**

- Would this be a R4UU within the new zoning structure? Still some discussions if there is to be a cap.
    - Secondary Plan consistency? Is the project in line with density provisions?
    - SD – Density provisions/values were removed on this site as part of the Beechwood CDP (report ACS2006-PRG-POL-0037, August 2006 report).
    - As per the comments from the RPRA, the VCA encourage a range of units sizes to accommodate for families as well as single persons.
    - Rooftop amenity space, R4 study is looking to potentially remove this provision. If this was to move forward a redesign would be required.
    - Beechwood Ave Community Design Plan should be considered.

**Other**

- BW – There are many opportunities along Carsdale if ownership of this space could be considered.
- JS - Existing infrastructure in Carsdale. Would be interested in improving the at grade treatment of the street. This would be subject to discussions with the City.

**Submission requirements and fees** (please see attachments)

**Next steps**

- Encourage applicant to discuss the proposal with Councillor, community groups and neighbours.
- Additional consultation with Heritage staff will be required.
- Please contact UDRP staff for submission dates and cut-offs.

## Alexander O'Beirn

---

**From:** Bruce Thomas  
**Sent:** Friday, December 11, 2020 3:31 PM  
**To:** Alexander O'Beirn  
**Cc:** Jason Fitzpatrick  
**Subject:** FW: Request for Boundary Conditions for 229, 241 Beechwood Avenue.

FYI

### **Bruce Thomas, P.Eng.**

EXP | Senior Project Manager

t : +1.613.688.1899 | m : +1.613.852.8753 | e : [bruce.thomas@exp.com](mailto:bruce.thomas@exp.com)

*[exp.com](#) | [legal disclaimer](#)*

*keep it green, read from the screen*

---

**From:** Wessel, Shawn <[shawn.wessel@ottawa.ca](mailto:shawn.wessel@ottawa.ca)>  
**Sent:** Friday, December 11, 2020 2:31 PM  
**To:** Jason Fitzpatrick <[jason.fitzpatrick@exp.com](mailto:jason.fitzpatrick@exp.com)>  
**Cc:** Bruce Thomas <[bruce.thomas@exp.com](mailto:bruce.thomas@exp.com)>  
**Subject:** RE: Request for Boundary Conditions for 229, 241 Beechwood Avenue.

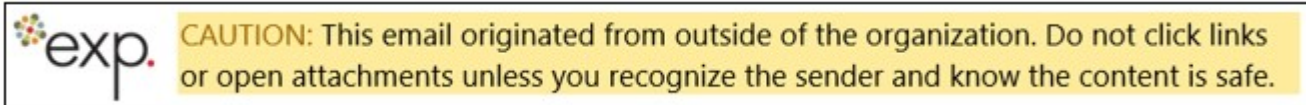

Please also add the following to the boundary conditions provided in the last email:

The maximum pressure is estimated to be more than 80 psi. A pressure check at completion of construction is recommended to determine if pressure control is required.

If you require additional information or clarification, please do not hesitate to contact me anytime.

Thank you

*Regards,*

### **Shawn Wessel, A.Sc.T.,rcji**

**Project Manager - Infrastructure Approvals**

**Gestionnaire de projet – Approbation des demandes d’infrastructures**

Development Review Central Branch | Direction de l'examen des projets d'aménagement, Centrale  
Planning, Infrastructure and Economic Development Department | Direction générale de la planification  
de l'infrastructure et du développement économique  
City of Ottawa | Ville d'Ottawa

110 Laurier Ave. W. | 110, avenue Laurier Ouest, Ottawa ON K1P 1J1  
(613) 580 2424 Ext. | Poste 33017  
Int. Mail Code | Code de Courrier Interne 01-14  
[shawn.wessel@ottawa.ca](mailto:shawn.wessel@ottawa.ca)

 Please consider the environment before printing this email



**\*\*\*Please also note that, while my work hours may be affected by the current situation and am working from home, I still have access to email, video conferencing and telephone. Feel free to schedule video conferences and/or telephone calls, as necessary.\*\*\***

---

**From:** Wessel, Shawn  
**Sent:** December 11, 2020 9:21 AM  
**To:** Jason Fitzpatrick <[jason.fitzpatrick@exp.com](mailto:jason.fitzpatrick@exp.com)>  
**Cc:** Bruce Thomas <[Bruce.Thomas@exp.com](mailto:Bruce.Thomas@exp.com)>  
**Subject:** RE: Request for Boundary Conditions for 229, 241 Beechwood Avenue.

Good morning Jason.

Just received them.

Here you are, as requested:

The following are boundary conditions, HGL, for hydraulic analysis at 229-241 Beechwood (zone 1E) assumed both connections to be connected to the 254mm on Beechwood Avenue (see attached PDF for location).

Both Connections:

Minimum HGL = 107.8m

Maximum HGL = 118.2m

Connection A: MaxDay + Fire Flow (217 L/s) = 102.0m

Connection B: MaxDay + Fire Flow (250 L/s) = 100.2m

These are for current conditions and are based on computer model simulation.

*Disclaimer: The boundary condition information is based on current operation of the city water distribution system. The computer model simulation is based on the best information available at the time. The operation of the water distribution system can change on a regular basis, resulting in a variation in boundary conditions. The physical properties of watermains deteriorate over time, as such must be assumed in the absence of actual field test data. The variation in physical watermain properties can therefore alter the results of the computer model simulation.*

If you require additional information or clarification, please do not hesitate to contact me anytime.

Thank you

*Regards,*

**Shawn Wessel, A.Sc.T.,rcji**  
**Project Manager - Infrastructure Approvals**  
**Gestionnaire de projet – Approbation des demandes d’infrastructures**

Development Review Central Branch | Direction de l’examen des projets d’aménagement, Centrale  
Planning, Infrastructure and Economic Development Department | Direction générale de la planification  
de l’infrastructure et du développement économique  
City of Ottawa | Ville d’Ottawa  
110 Laurier Ave. W. | 110, avenue Laurier Ouest, Ottawa ON K1P 1J1  
(613) 580 2424 Ext. | Poste 33017  
Int. Mail Code | Code de Courrier Interne 01-14  
[shawn.wessel@ottawa.ca](mailto:shawn.wessel@ottawa.ca)

 Please consider the environment before printing this email



**\*\*\*Please also note that, while my work hours may be affected by the current situation and am working from home, I still have access to email, video conferencing and telephone. Feel free to schedule video conferences and/or telephone calls, as necessary.\*\*\***

---

**From:** Jason Fitzpatrick <[jason.fitzpatrick@exp.com](mailto:jason.fitzpatrick@exp.com)>  
**Sent:** December 11, 2020 8:10 AM  
**To:** Wessel, Shawn <[shawn.wessel@ottawa.ca](mailto:shawn.wessel@ottawa.ca)>  
**Cc:** Bruce Thomas <[Bruce.Thomas@exp.com](mailto:Bruce.Thomas@exp.com)>  
**Subject:** RE: Request for Boundary Conditions for 229, 241 Beechwood Avenue.

**CAUTION: This email originated from an External Sender. Please do not click links or open attachments unless you recognize the source.**

**ATTENTION : Ce courriel provient d’un expéditeur externe. Ne cliquez sur aucun lien et n’ouvrez pas de pièce jointe, excepté si vous connaissez l’expéditeur.**

Hi Shawn,

Can you check with Water Resources on an estimated timeline for providing, as we were hoping to submit shortly.

**Jason Fitzpatrick, P.Eng.**

EXP | Project Engineer

t : +1.613.688.1899 | m : +1.613.302.7441 | e : [jason.fitzpatrick@exp.com](mailto:jason.fitzpatrick@exp.com)

*[exp.com](#) | [legal disclaimer](#)*

*keep it green, read from the screen*

---

**From:** Wessel, Shawn <[shawn.wessel@ottawa.ca](mailto:shawn.wessel@ottawa.ca)>  
**Sent:** Monday, December 7, 2020 11:24 AM  
**To:** Jason Fitzpatrick <[jason.fitzpatrick@exp.com](mailto:jason.fitzpatrick@exp.com)>  
**Cc:** Bruce Thomas <[bruce.thomas@exp.com](mailto:bruce.thomas@exp.com)>  
**Subject:** RE: Request for Boundary Conditions for 229, 241 Beechwood Avenue.

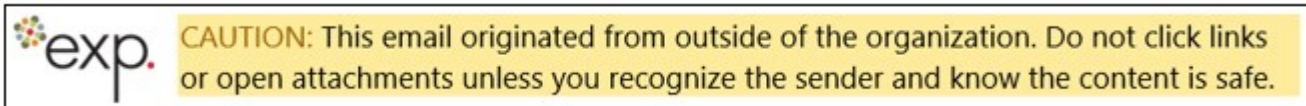

Thank you Jason.

Sent to WDD for their comments.

If you require additional information or clarification, please do not hesitate to contact me anytime.

Thank you

*Regards,*

**Shawn Wessel, A.Sc.T.,rcji**

**Project Manager - Infrastructure Approvals**

**Gestionnaire de projet – Approbation des demandes d’infrastructures**

Development Review Central Branch | Direction de l’examen des projets d’aménagement, Centrale  
Planning, Infrastructure and Economic Development Department | Direction générale de la planification  
de l’infrastructure et du développement économique

City of Ottawa | Ville d’Ottawa

110 Laurier Ave. W. | 110, avenue Laurier Ouest, Ottawa ON K1P 1J1

(613) 580 2424 Ext. | Poste 33017

Int. Mail Code | Code de Courrier Interne 01-14

[shawn.wessel@ottawa.ca](mailto:shawn.wessel@ottawa.ca)



**\*\*\*Please also note that, while my work hours may be affected by the current situation and am working from home, I still have access to email, video conferencing and telephone. Feel free to schedule video conferences and/or telephone calls, as necessary.\*\*\***

---

**From:** Jason Fitzpatrick <[jason.fitzpatrick@exp.com](mailto:jason.fitzpatrick@exp.com)>  
**Sent:** December 07, 2020 11:12 AM  
**To:** Wessel, Shawn <[shawn.wessel@ottawa.ca](mailto:shawn.wessel@ottawa.ca)>  
**Cc:** Bruce Thomas <[Bruce.Thomas@exp.com](mailto:Bruce.Thomas@exp.com)>  
**Subject:** FW: Request for Boundary Conditions for 229, 241 Beechwood Avenue.

**CAUTION: This email originated from an External Sender. Please do not click links or open attachments unless you recognize the source.**

**ATTENTION : Ce courriel provient d'un expéditeur externe. Ne cliquez sur aucun lien et n'ouvrez pas de pièce jointe, excepté si vous connaissez l'expéditeur.**

Hi Shawn,

We are working with Smart Living Properties on a site plan application, and would appreciate if you could arrange for IAD to provide hydraulic boundary conditions that we will need for water system design.

I have attached a site location plan showing the approximate boundary condition locations. We'd appreciate two boundary condition locations, as there will be two separate connections to the water system. I have attached design tables indicating the water demands and fire flow requirements based on the FUS Method.

The following is a summary of the demands and fire flow requirements we have estimated based on the current proposal.

Avg Day Demand	= 0.5 L/sec
Max Day Demand	= 3.0 L/sec
Peak Hour Demand	= 4.5 L/sec
Fire Flow Requirement	= 217 L/sec (229 Beechwood)
	= 250 L/sec (241 Beechwood)

If you have any questions, feel free to contact me.

Regards,





**Jason Fitzpatrick, P.Eng.**

EXP | Project Engineer

t : +1.613.688.1899 | m : +1.613.302.7441 | e : [jason.fitzpatrick@exp.com](mailto:jason.fitzpatrick@exp.com)

2650 Queensview Drive

Suite 100

Ottawa, ON K2B 8H6

CANADA

*[exp.com](#) | [legal disclaimer](#)*

*keep it green, read from the screen*

'  
'  

This e-mail originates from the City of Ottawa e-mail system. Any distribution, use or copying of this e-mail or the information it contains by other than the intended recipient(s) is unauthorized. Thank you.

Le présent courriel a été expédié par le système de courriels de la Ville d'Ottawa. Toute distribution, utilisation ou reproduction du courriel ou des renseignements qui s'y trouvent par une personne autre que son destinataire prévu est interdite. Je vous remercie de votre collaboration.

'  
'  

This e-mail originates from the City of Ottawa e-mail system. Any distribution, use or copying of this e-mail or the information it contains by other than the intended recipient(s) is unauthorized. Thank you.

Le présent courriel a été expédié par le système de courriels de la Ville d'Ottawa. Toute distribution, utilisation ou reproduction du courriel ou des renseignements qui s'y trouvent par une personne autre que son destinataire prévu est interdite. Je vous remercie de votre collaboration.

## Alexander Cole

---

**From:** Eric Lalande <eric.lalande@rvca.ca>  
**Sent:** Monday, March 14, 2022 5:25 PM  
**To:** Alexander Cole  
**Subject:** RE: 229 - 241 Beechwood Avenue



**CAUTION:** This email originated from outside of the organization. Do not click links or open attachments unless you recognize the sender and know the content is safe.

Hi Alexander,

Based on the Site Plans and information provided, the RVCA has no additional water quality protection requirements. Best management is encouraged where possible.

Thank you,

**Eric Lalande, MCIP, RPP**  
Planner, RVCA  
613-692-3571 x1137

---

**From:** Alexander Cole <Alexander.Cole@exp.com>  
**Sent:** Monday, March 14, 2022 3:12 PM  
**To:** Eric Lalande <eric.lalande@rvca.ca>  
**Cc:** Bruce Thomas <bruce.thomas@exp.com>; Jason Fitzpatrick <jason.fitzpatrick@exp.com>  
**Subject:** RE: 229 - 241 Beechwood Avenue

Hi Eric,

Please see attached the most recent site plan. Things are not yet finalized, was just hoping to get an understanding on the quality control. I saw another project very close to our site on Beechwood Ave. that did not require additional quality control and was wondering if our site could follow the same requirements.

Thanks,

## Alexander Cole

EXP | Engineering Designer

t : +1.613.688.1899, 63223 | m : +1.613.415.8783 | e : [alexander.cole@exp.com](mailto:alexander.cole@exp.com)

[exp.com](http://exp.com) | [legal disclaimer](#)

*keep it green, read from the screen*

---

**From:** Eric Lalande <[eric.lalande@rvca.ca](mailto:eric.lalande@rvca.ca)>  
**Sent:** Monday, March 14, 2022 8:56 AM  
**To:** Alexander Cole <[Alexander.Cole@exp.com](mailto:Alexander.Cole@exp.com)>  
**Subject:** RE: 229 - 241 Beechwood Avenue



CAUTION: This email originated from outside of the organization. Do not click links or open attachments unless you recognize the sender and know the content is safe.

Hi Alexander,

Do you have a site plan for me to review as part of this request?

Thank you,

**Eric Lalande, MCIP, RPP**  
Planner, RVCA  
613-692-3571 x1137

---

**From:** Alexander Cole <[Alexander.Cole@exp.com](mailto:Alexander.Cole@exp.com)>  
**Sent:** Friday, March 11, 2022 9:36 AM  
**To:** Eric Lalande <[eric.lalande@rvca.ca](mailto:eric.lalande@rvca.ca)>  
**Cc:** Bruce Thomas <[bruce.thomas@exp.com](mailto:bruce.thomas@exp.com)>; Jason Fitzpatrick <[jason.fitzpatrick@exp.com](mailto:jason.fitzpatrick@exp.com)>  
**Subject:** 229 - 241 Beechwood Avenue

Hi Eric,

We are currently working on a development at 229 and 241 Beechwood Avenue. It is our understanding that the quality control is handled in the existing infrastructure since it outlets to the Ottawa River over 2000m downstream. Could you please confirm to ensure we do not need additional quality control?

Thanks,



**Alexander Cole**

EXP | Engineering Designer  
t : +1.613.688.1899, 63223 | m : +1.613.415.8783 | e : [alexander.cole@exp.com](mailto:alexander.cole@exp.com)  
2650 Queensview Drive  
Suite 100  
Ottawa, ON K2B 8H6  
CANADA

[exp.com](http://exp.com) | [legal disclaimer](#)

*keep it green, read from the screen*

## **Appendix C – Background Information**

**IPEX LMF 75 ICD Specifications**

**Watts Adjustable Flow Control Drains Specifications**

**Servicing Guidelines for Development Applications Checklist**

**City of Ottawa Vault Drawings (Plan and Profiles)**

# Volume III: TEMPEST™ INLET CONTROL DEVICES

Municipal Technical  
Manual Series

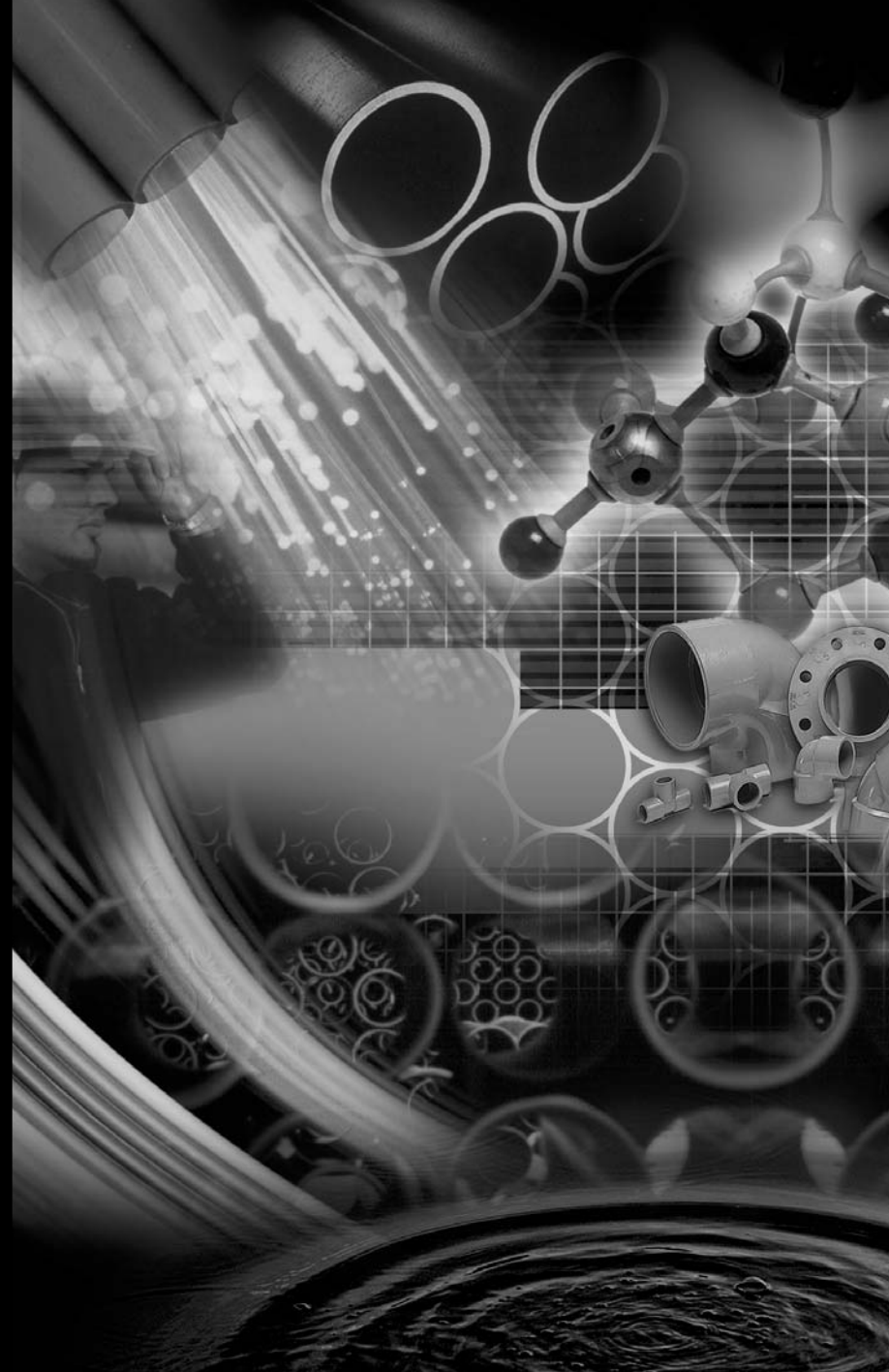

SECOND EDITION

**LMF (Low to Medium Flow) ICD**

**HF (High Flow) ICD**

**MHF (Medium to High Flow) ICD**



**IPEX**

# IPEX Tempest™ Inlet Control Devices

Municipal Technical Manual Series

Vol. I, 2nd Edition

© 2012 by IPEX. All rights reserved. No part of this book may be used or reproduced in any manner whatsoever without prior written permission. For information contact: IPEX, Marketing, 2441 Royal Windsor Drive, Mississauga, Ontario, Canada, L5J 4C7.

The information contained here within is based on current information and product design at the time of publication and is subject to change without notification. IPEX does not guarantee or warranty the accuracy, suitability for particular applications, or results to be obtained therefrom.

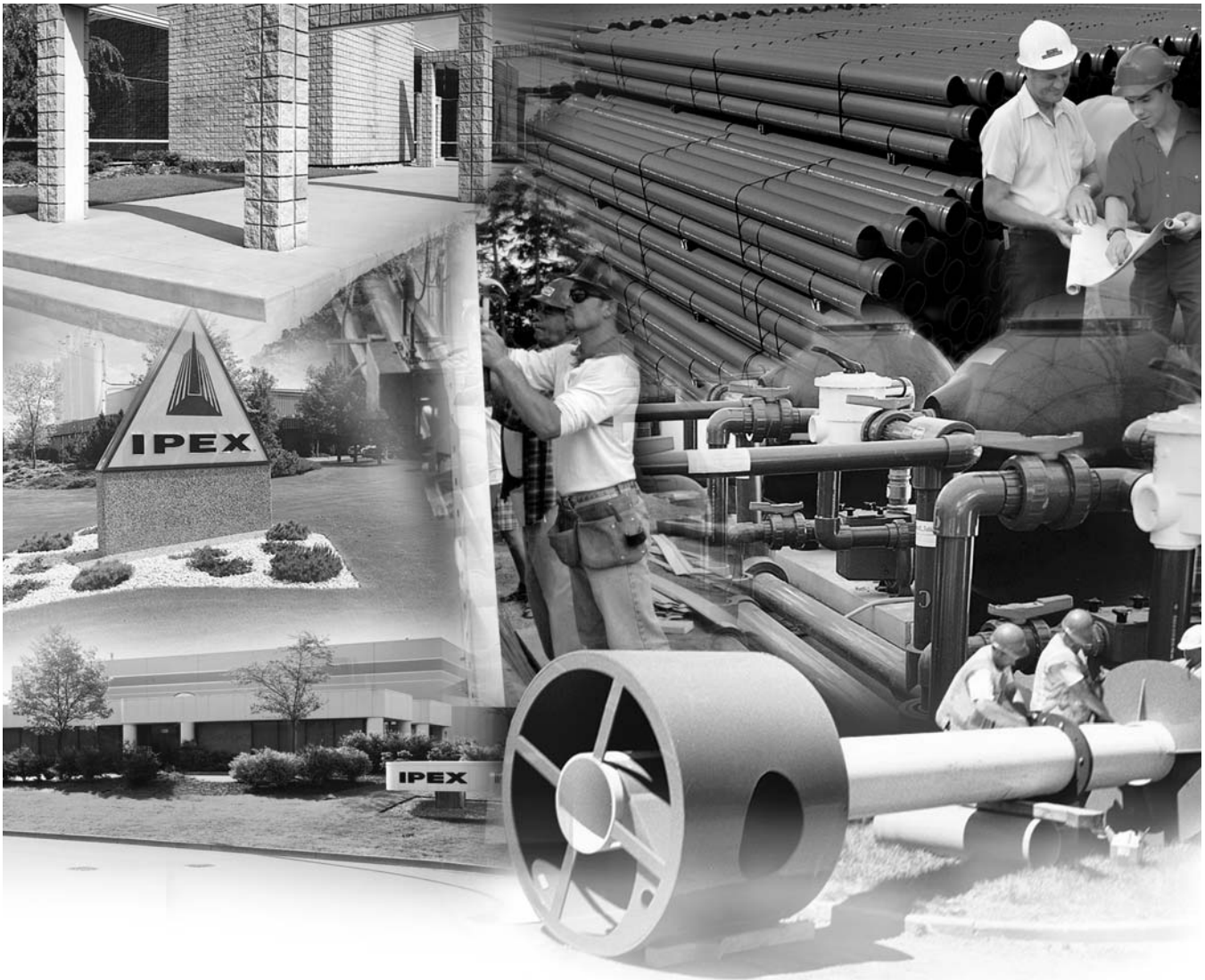

## **ABOUT IPEX**

At IPEX, we have been manufacturing non-metallic pipe and fittings since 1951. We formulate our own compounds and maintain strict quality control during production. Our products are made available for customers thanks to a network of regional stocking locations throughout North America. We offer a wide variety of systems including complete lines of piping, fittings, valves and custom-fabricated items.

More importantly, we are committed to meeting our customers' needs. As a leader in the plastic piping industry, IPEX continually develops new products, modernizes manufacturing facilities and acquires innovative process technology. In addition, our staff take pride in their work, making available to customers their extensive thermoplastic knowledge and field experience. IPEX personnel are committed to improving the safety, reliability and performance of thermoplastic materials. We are involved in several standards committees and are members of and/or comply with the organizations listed on this page.

For specific details about any IPEX product, contact our customer service department.

# CONTENTS

## TEMPEST INLET CONTROL DEVICES Technical Manual

About IPEX

<b>Section One:</b>	<b>Product Information: TEMPEST Low, Medium Flow (LMF) ICD</b>	
	Purpose . . . . .	4
	Product Description . . . . .	4
	Product Function . . . . .	4
	Product Construction . . . . .	4
	Product Applications . . . . .	4
	Chart 1: LMF 14 Preset Flow Curves . . . . .	5
	Chart 2: LMF Flow Vs. ICD Alternatives . . . . .	5
	<b>Product Installation</b>	
	Instructions to assemble a TEMPEST LMF ICD into a square catch basin: . . . . .	6
	Instructions to assemble a TEMPEST LMF ICD into a round catch basin: . . . . .	6
	<b>Product Technical Specification</b>	
	General . . . . .	7
	Materials . . . . .	7
	Dimensioning . . . . .	7
	Installation . . . . .	7
<b>Section Two:</b>	<b>Product Information: TEMPEST High Flow (HF) &amp; Medium, High Flow (MHF) ICD</b>	
	Product Description . . . . .	8
	Product Function . . . . .	8
	Product Construction . . . . .	8
	Product Applications . . . . .	8
	Chart 3: HF & MHF Preset Flow Curves . . . . .	9
	<b>Product Installation</b>	
	Instructions to assemble a TEMPEST HF or MHF ICD into a square catch basin: . . . . .	10
	Instructions to assemble a TEMPEST HF or MHF ICD into a round catch basin: . . . . .	10
	Instructions to assemble a TEMPEST HF Sump into a square or round catch basin: . . . . .	11
	<b>Product Technical Specification</b>	
	General . . . . .	11
	Materials . . . . .	11
	Dimensioning . . . . .	11
	Installation . . . . .	11



## PRODUCT INFORMATION: TEMPEST LOW, MEDIUM FLOW (LMF) ICD

### Purpose

To control the amount of storm water runoff entering a sewer system by allowing a specified flow volume out of a catch basin or manhole at a specified head. This approach conserves pipe capacity so that catch basins downstream do not become uncontrollably surcharged, which can lead to basement floods, flash floods and combined sewer overflows.

### Product Description

Our LMF ICD is designed to accommodate catch basins or manholes with sewer outlet pipes 6" in diameter and larger. Any storm sewer larger than 12" may require custom modification. However, IPEX can custom build a TEMPEST device to accommodate virtually any storm sewer size.

Available in 14 preset flow curves, the LMF ICD has the ability to provide flow rates: 2lps – 17lps (31gpm – 270gpm)

### Product Function

The LMF ICD vortex flow action allows the LMF ICD to provide a narrower flow curve using a larger orifice than a conventional orifice plate ICD, making it less likely to clog. When comparing flows at the same head level, the LMF ICD has the ability to restrict more flow than a conventional ICD during a rain event, preserving greater sewer capacity.

### Product Construction

Constructed from durable PVC, the LMF ICD is light weight 8.9 Kg (19.7 lbs).

### Product Applications

Will accommodate both square and round applications:

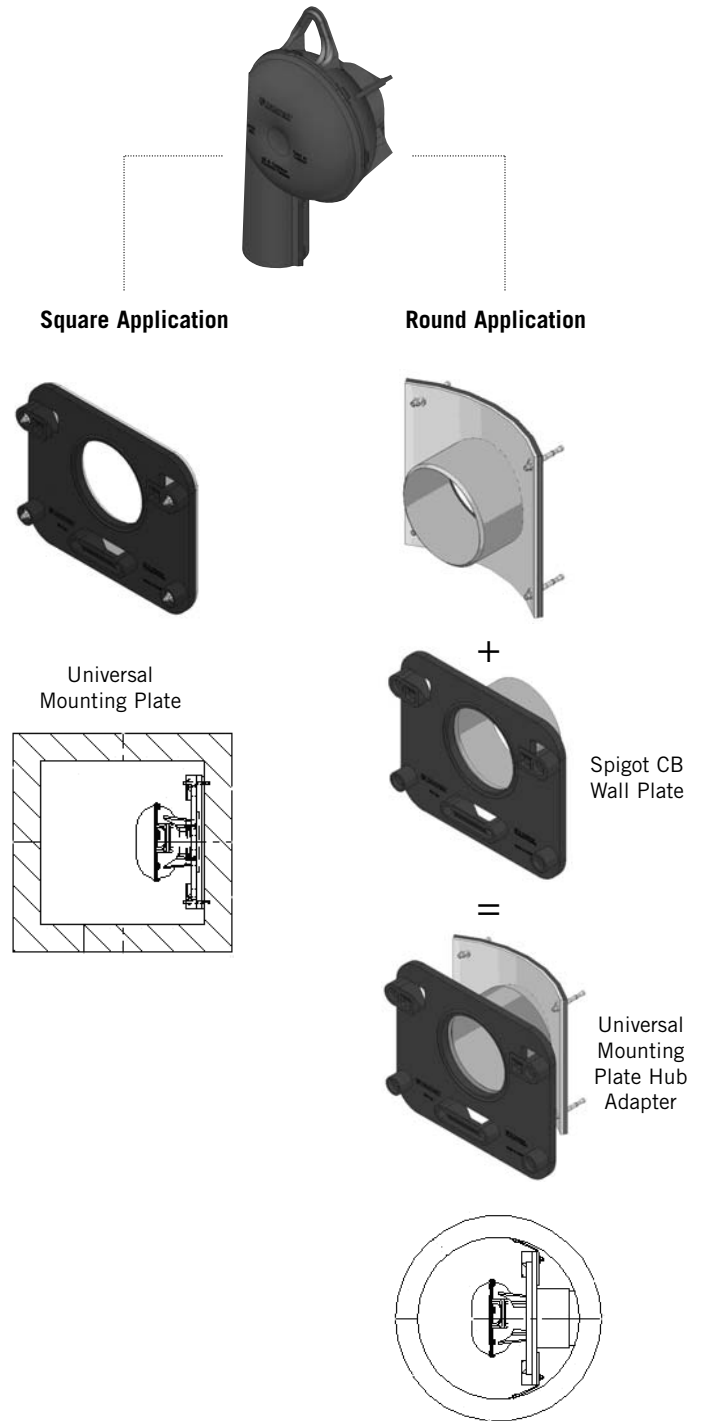

**Chart 1: LMF 14 Preset Flow Curves**

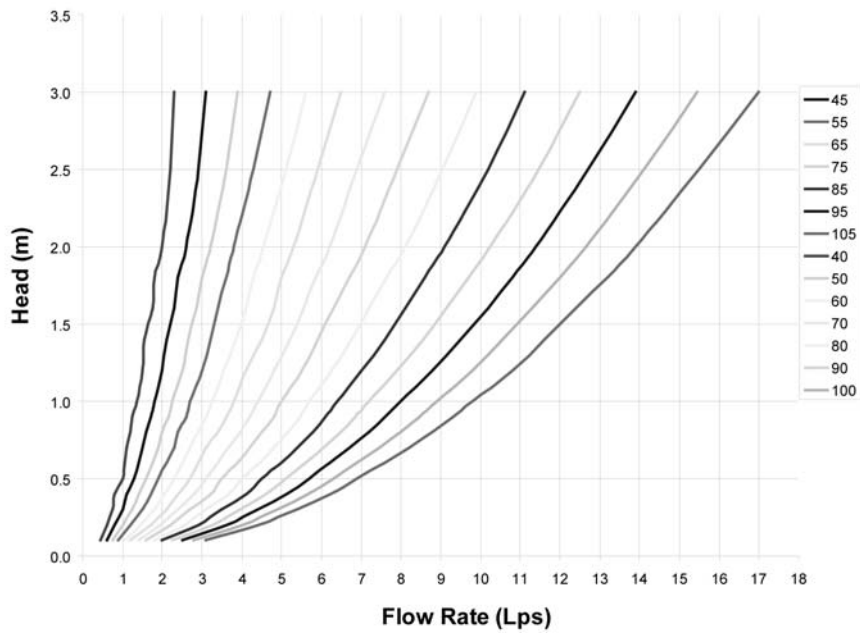

**Chart 2: LMF Flow vs. ICD Alternatives**

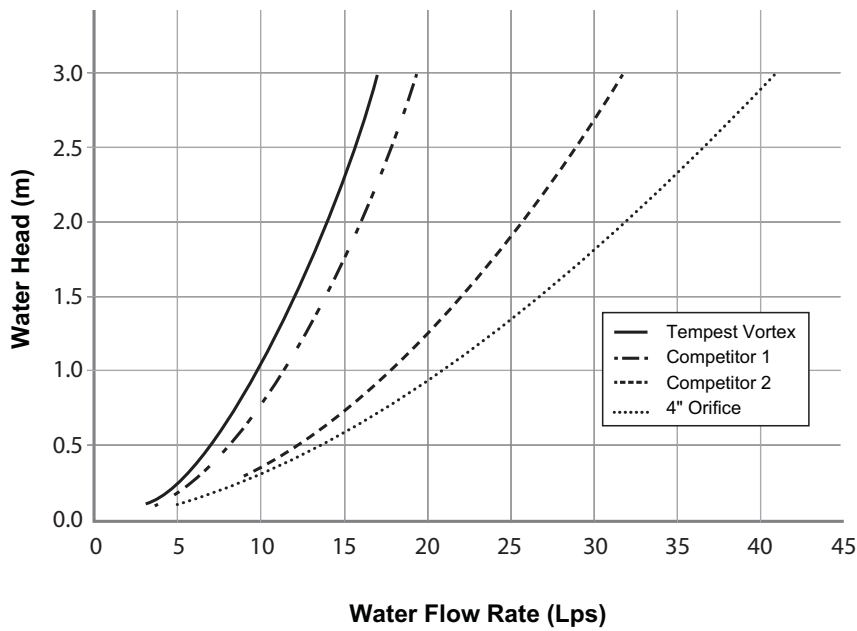

## PRODUCT INSTALLATION

### Instructions to assemble a TEMPEST LMF ICD into a Square Catch Basin:

#### STEPS:

1. Materials and tooling verification:
  - Tooling: impact drill, 3/8" concrete bit, torque wrench for 9/16" nut, hand hammer, level, and marker.
  - Material: (4) concrete anchor 3/8 x 3-1/2, (4) washers, (4) nuts, universal mounting plate, ICD device.
2. Use the mounting wall plate to locate and mark the hole (4) pattern on the catch basin wall. You should use a level to ensure that the plate is at the horizontal.
3. Use an impact drill with a 3/8" concrete bit to make the four holes at a minimum of 1-1/2" depth up to 2-1/2". Clean the concrete dust from the holes.
4. Install the anchors (4) in the holes by using a hammer. Thread the nuts on the top of the anchors to protect the threads when you hit the anchors with the hammer. Remove the nuts from the ends of the anchors.
5. Install the universal mounting plate on the anchors and screw the 4 nuts in place with a maximum torque of 40 N.m (30 lbf-ft). There should be no gap between the wall mounting plate and the catch basin wall.
6. From the ground above using a reach bar, lower the ICD device by hooking the end of the reach bar to the handle of the ICD device. Align the triangular plate portion into the mounting wall plate. Push down the device to be sure it has centered in to the universal mounting plate and has created a seal.



#### WARNING

- Verify that the outlet pipe doesn't protrude into the catch basin. If it does, cut down the pipe flush to the catch basin wall.
- Call your IPEX representative for more information or if you have any questions about our products.

### Instructions to assemble a TEMPEST LMF ICD into a Round Catch Basin:

#### STEPS:

1. Materials and tooling verification.
  - Tooling: impact drill, 3/8" concrete bit, torque wrench for 9/16" nut, hand hammer, level and marker.
  - Material: (4) concrete anchor 3/8 x 3-1/2, (4) washers and (4) nuts, spigot CB wall plate, universal mounting plate hub adapter, ICD device.
2. Use the spigot catch basin wall plate to locate and mark the hole (4) pattern on the catch basin wall. You should use a level to ensure that the plate is at the horizontal.
3. Use an impact drill with a 3/8" concrete bit to make the four holes at a depth between 1-1/2" to 2-1/2". Clean the concrete dust from the holes.
4. Install the anchors (4) in the holes by using a hammer. Thread the nuts on the top of the anchors to protect the threads when you hit the anchors with the hammer. Remove the nuts from the ends of the anchors.
5. Install the CB spigot wall plate on the anchors and screw the 4 nuts in place with a maximum torque of 40 N.m (30 lbf-ft). There should be no gap between the spigot wall plate and the catch basin wall.
6. Apply solvent cement on the hub of the universal mounting plate, hub adapter and the spigot of the CB wall plate, then slide the hub over the spigot. Make sure the universal mounting plate is at the horizontal and its hub is completely inserted onto the spigot. Normally, the corners of the universal mounting plate hub adapter should touch the catch basin wall.
7. From ground above using a reach bar, lower the ICD device by hooking the end of the reach bar to the handle of the ICD device. Align the triangular plate portion into the mounting wall plate. Push down the device to be sure it has centered in to the mounting plate and has created a seal.



#### WARNING

- Verify that the outlet pipe doesn't protrude into the catch basin. If it does, cut back the pipe flush to the catch basin wall.
- The solvent cement which is used in this installation is to be approved for PVC.
- The solvent cement should not be used below 0°C (32°F) or in a high humidity environment. Refer to the IPEX solvent cement guide to confirm the required curing time or visit the IPEX Online Solvent Cement Training Course available at [www.ipexinc.com](http://www.ipexinc.com).
- Call your IPEX representative for more information or if you have any questions about our products.

## PRODUCT TECHNICAL SPECIFICATION

### General

Inlet control devices (ICD's) are designed to provide flow control at a specified rate for a given water head level and also provide odour and floatable control. All ICD's will be IPEX Tempest or approved equal.

All devices shall be removable from a universal mounting plate. An operator from street level using only a T-bar with a hook will be able to retrieve the device while leaving the universal mounting plate secured to the catch basin wall face. The removal of the TEMPEST devices listed above must not require any unbolting or special manipulation or any special tools.

High Flow (HF) Sump devices will consist of a removable threaded cap which can be accessible from street level with out entry into the catchbasin (CB). The removal of the threaded cap shall not require any special tools other than the operator's hand.

ICD's shall have no moving parts.

### Materials

ICD's are to be manufactured from Polyvinyl Chloride (PVC) or Polyurethane material, designed to be durable enough to withstand multiple freeze-thaw cycles and exposure to harsh elements.

The inner ring seal will be manufactured using a Buna or Nitrile material with hardness between Duro 50 and Duro 70.

The wall seal is to be comprised of a 3/8" thick Neoprene Closed Cell Sponge gasket which is attached to the back of the wall plate.

All hardware will be made from 304 stainless steel.

### Dimensioning

The Low Medium Flow (LMF), High Flow (HF) and the High Flow (HF) Sump shall allow for a minimum outlet pipe diameter of 200mm with a 600mm deep Catch Basin sump.

### Installation

Contractor shall be responsible for securing, supporting and connecting the ICD's to the existing influent pipe and catchbasin/manhole structure as specified and designed by the Engineer.

## PRODUCT INFORMATION: TEMPEST HF & MHF ICD

### Product Description

Our HF, HF Sump and MHF ICD's are designed to accommodate catch basins or manholes with sewer outlet pipes 6" in diameter or larger. Any storm sewer larger than 12" may require custom modification. However, IPEX can custom build a TEMPEST device to accommodate virtually any storm sewer size.

Available in 5 preset flow curves, these ICDs have the ability to provide constant flow rates: 9lps (143 gpm) and greater

### Product Function

**TEMPEST HF (High Flow):** designed to manage moderate to higher flows 15 L/s (240 gpm) or greater and prevent the propagation of odour and floatables. With this device, the cross-sectional area of the device is larger than the orifice diameter and has been designed to limit head losses. The HF ICD can also be ordered without flow control when only odour and floatable control is required.



**TEMPEST HF (High Flow) Sump:** The height of a sewer outlet pipe in a catch basin is not always conveniently located. At times it may be located very close to the catch basin floor, not providing enough sump for one of the other TEMPEST ICDs with universal back plate to be installed. In these applications, the HF Sump is offered. The HF Sump offers the same features and benefits as the HF ICD; however, is designed to raise the outlet in a square or round catch basin structure. When installed, the HF sump is fixed in place and not easily removed. Any required service to the device is performed through a clean-out located in the top of the device which can be often accessed from ground level.

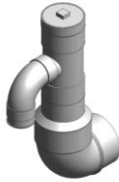

### TEMPEST MHF (Medium to High Flow):

The MHF plate or plug is designed to control flow rates 9 L/s (143 gpm) or greater. It is not designed to prevent the propagation of odour and floatables.



### Product Construction

The HF, HF Sump and MHF ICDs are built to be light weight at a maximum weight of 6.8 Kg (14.6 lbs).

### Product Applications

The HF and MHF ICD's are available to accommodate both square and round applications:



#### Square Application

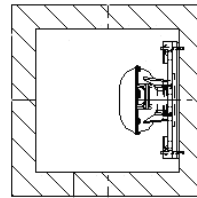

#### Round Application

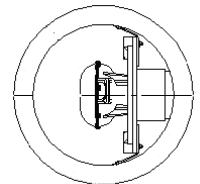
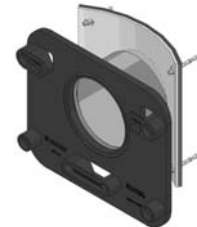

The HF Sump is available to accommodate low to no sump applications in both square and round catch basins:

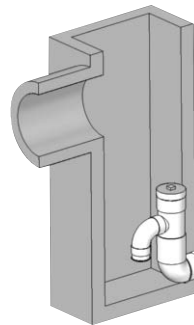

Square Catch Basin

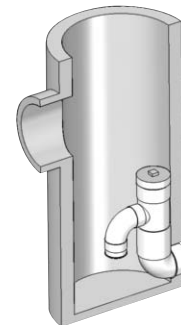

Round Catch Basin

**Chart 3: HF & MHF Preset Flow Curves**

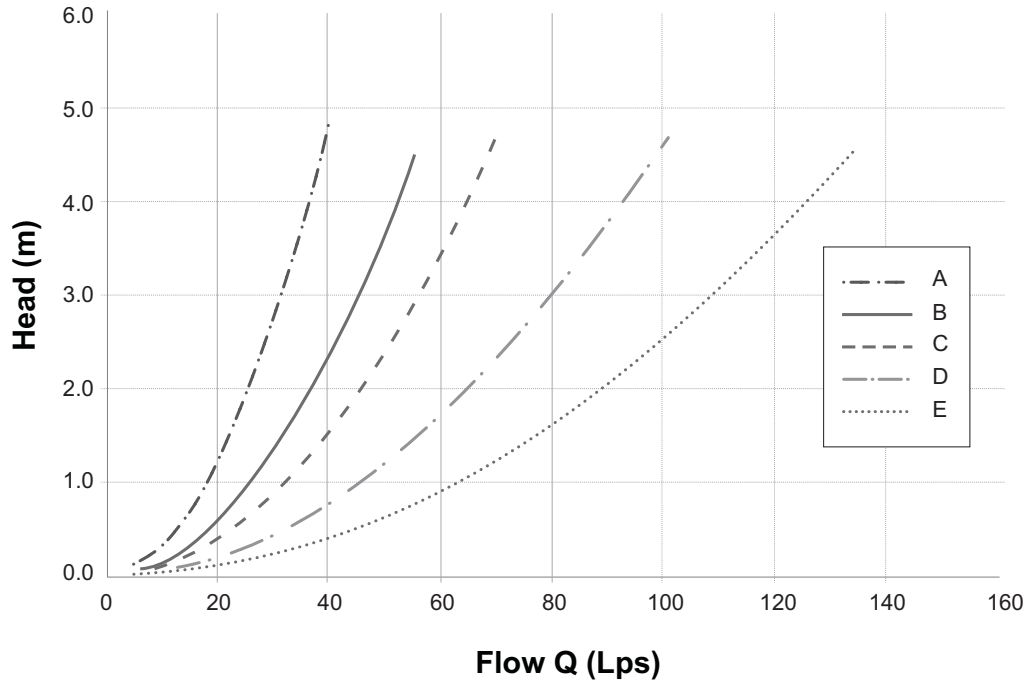

TEMPEST  
 HF & MHF ICD

## PRODUCT INSTALLATION

### Instructions to assemble a TEMPEST HF or MHF ICD into a Square Catch Basin:

1. Materials and tooling verification:
  - Tooling: impact drill, 3/8" concrete bit, torque wrench for 9/16" nut, hand hammer, level, and marker.
  - Material: (4) concrete anchor 3/8 x 3-1/2, (4) washers, (4) nuts, universal mounting plate, ICD device
2. Use the mounting wall plate to locate and mark the hole (4) pattern on the catch basin wall. You should use a level to ensure that the plate is at the horizontal.
3. Use an impact drill with a 3/8" concrete bit to make the four holes at a minimum of 1-1/2" depth up to 2-1/2". Clean the concrete dust from the holes.
4. Install the anchors (4) in the holes by using a hammer. Thread the nuts on the top of the anchors to protect the threads when you hit the anchors with the hammer. Remove the nuts from the ends of the anchors.
5. Install the universal wall mounting plate on the anchors and screw the 4 nuts in place with a maximum torque of 40 N.m (30 lbf-ft). There should be no gap between the wall mounting plate and the catch basin wall.
6. From the ground above using a reach bar, lower the device by hooking the end of the reach bar to the handle of the ICD device. Align the triangular plate portion into the mounting wall plate. Push down the device to be sure it has centered in to the universal wall mounting plate and has created a seal.



### WARNING

- Verify that the outlet pipe doesn't protrude into the catch basin. If it does, cut down the pipe flush to the catch basin wall.
- Call your IPEX representative for more information or if you have any questions about our products.

### Instructions to assemble a TEMPEST HF or MHF ICD into a Round Catch Basin:

#### STEPS:

1. Materials and tooling verification.
  - Tooling: impact drill, 3/8" concrete bit, torque wrench for 9/16" nut, hand hammer, level and marker.
  - Material: (4) concrete anchor 3/8 x 3-1/2, (4) washers and (4) nuts, spigot CB wall plate, universal mounting plate hub adaptor, ICD device.
2. Use the round catch basin spigot adaptor to locate and mark the hole (4) pattern on the catch basin wall. You should use a level to ensure that the plate is at the horizontal.
3. Use an impact drill with a 3/8" concrete bit to make the four holes at a depth between 1-1/2" to 2-1/2". Clean the concrete dust from the holes.
4. Install the anchors (4) in the holes by using a hammer. Thread the nuts on the top of the anchors to protect the threads when you hit the anchors with the hammer. Remove the nuts from the ends of the anchors.
5. Install the spigot CB wall plate on the anchors and screw the 4 nuts in place with a maximum torque of 40 N.m (30 lbf-ft). There should be no gap between the spigot CB wall plate and the catch basin wall.
6. Put solvent cement on the hub of the universal mounting plate, hub adaptor and the spigot of the CB wall plate, then slide the hub over the spigot. Make sure the universal mounting plate is at the horizontal and its hub is completely inserted onto the spigot. Normally, the corners of the hub adaptor should touch the catch basin wall.
7. From ground above using a reach bar, lower the device by hooking the end of the reach bar to the handle of the ICD device. Align the triangular plate portion into the mounting wall plate. Push down the device to be sure it has centered in to the wall mounting plate and has created a seal.



### WARNING

- Verify that the outlet pipe doesn't protrude into the catch basin. If it does, cut down the pipe flush to the catch basin wall.
- The solvent cement which is used in this installation is to be approved for PVC.
- The solvent cement should not be used below 0°C (32°F) or in a high humidity environment. Refer to the IPEX solvent cement guide to confirm the required curing time or visit the IPEX Online Solvent Cement Training Course available at [www.ipexinc.com](http://www.ipexinc.com).
- Call your IPEX representative for more information or if you have any questions about our products.

## Instructions to assemble a TEMPEST HF Sump into a Square or Round Catch Basin:

### STEPS:

1. Materials and tooling verification:
  - Tooling: impact drill, 3/8" concrete bit, torque wrench for 9/16" nut, hand hammer, level, mastic tape and metal strapping
  - Material: (2) concrete anchor 3/8 x 3-1/2, (2) washers, (2) nuts, HF Sump pieces (2).
2. Apply solvent cement to the spigot end of the top half of the sump. Apply solvent cement to the hub of the bottom half of the sump. Insert the spigot of the top half of the sump into the hub of the bottom half of the sump.
3. Install the 8" spigot of the device into the outlet pipe. Use the mastic tape to seal the device spigot into the outlet pipe. You should use a level to be sure that the fitting is standing at the vertical.
4. Use an impact drill with a 3/8" concrete bit to make a series of 2 holes along each side of the body throat. The depth of the hole should be between 1-1/2" to 2-1/2". Clean the concrete dust from the 2 holes.
5. Install the anchors (2) in the holes by using a hammer. Put the nuts on the top of the anchors to protect the threads when you hit the anchors. Remove the nuts from the ends of the anchors.
6. Cut the metal strapping to length and connect each end of the strapping to the anchors. Screw the nuts in place with a maximum torque of 40 N.m (30 lbf-ft). The device should be completely flush with the catch basin wall.



### WARNING

- Verify that the outlet pipe doesn't protrude into the catch basin. If it does, cut down the pipe flush to the catch basin wall.
- The solvent cement which is used in this installation is to be approved for PVC.
- The solvent cement should not be used below 0°C (32°F) or in a high humidity environment. Refer to the IPEX solvent cement guide to confirm the required curing time or visit the IPEX Online Solvent Cement Training Course available at [www.ipexinc.com](http://www.ipexinc.com).
- Call your IPEX representative for more information or if you have any questions about our products.

## PRODUCT TECHNICAL SPECIFICATION

### General

Inlet control devices (ICD's) are designed to provide flow control at a specified rate for a given water head level and also provide odour and floatable control where specified. All ICD's will be IPEX Tempest or approved equal.

All devices shall be removable from a universal mounting plate. An operator from street level using only a T-bar with a hook shall be able to retrieve the device while leaving the universal mounting plate secured to the catch basin wall face. The removal of the TEMPEST devices listed above shall not require any unbolting or special manipulation or any special tools.

High Flow (HF) Sump devices shall consist of a removable threaded cap which can be accessible from street level with out entry into the catchbasin (CB). The removal of the threaded cap shall not require any special tools other than the operator's hand.

ICD's shall have no moving parts.

### Materials

ICD's are to be manufactured from Polyvinyl Chloride (PVC) or Polyurethane material, designed to be durable enough to withstand multiple freeze-thaw cycles and exposure to harsh elements.

The inner ring seal will be manufactured using a Buna or Nitrile material with hardness between Duro 50 and Duro 70.

The wall seal is to be comprised of a 3/8" thick Neoprene Closed Cell Sponge gasket which is attached to the back of the wall plate.

All hardware will be made from 304 stainless steel.

### Dimensioning

The Low Medium Flow (LMF), High Flow (HF) and the High Flow (HF) Sump shall allow for a minimum outlet pipe diameter of 200mm with a 600mm deep Catch Basin sump.

### Installation

Contractor shall be responsible for securing, supporting and connecting the ICD's to the existing influent pipe and catchbasin/manhole structure as specified and designed by the Engineer.





# SALES AND CUSTOMER SERVICE

Canadian Customers call IPEX Inc.

**Toll free: (866) 473-9462**

**[www.ipexinc.com](http://www.ipexinc.com)**

U.S. Customers call IPEX USA LLC

**Toll free: (800) 463-9572**

**[www.ipexamerica.com](http://www.ipexamerica.com)**

## **About the IPEX Group of Companies**

As leading suppliers of thermoplastic piping systems, the IPEX Group of Companies provides our customers with some of the largest and most comprehensive product lines. All IPEX products are backed by more than 50 years of experience. With state-of-the-art manufacturing facilities and distribution centers across North America, we have established a reputation for product innovation, quality, end-user focus and performance.

Markets served by IPEX group products are:

- Electrical systems
- Telecommunications and utility piping systems
- PVC, CPVC, PP, ABS, PEX, FR-PVDF and PE pipe and fittings (1/4" to 48")
- Industrial process piping systems
- Municipal pressure and gravity piping systems
- Plumbing and mechanical piping systems
- PE Electrofusion systems for gas and water
- Industrial, plumbing and electrical cements
- Irrigation systems

Products manufactured by IPEX Inc. and distributed in the United States by IPEX USA LLC.

Tempest™ is a trademark of IPEX Branding Inc.

This literature is published in good faith and is believed to be reliable. However it does not represent and/or warrant in any manner the information and suggestions contained in this brochure. Data presented is the result of laboratory tests and field experience.

A policy of ongoing product improvement is maintained. This may result in modifications of features and/or specifications without notice.

MNMNTPIP110817  
© 2012 IPEX MN0038UC



**IPEX**



**Adjustable Accutrol Weir**  
 Tag: \_\_\_\_\_

**Adjustable Flow Control  
 for Roof Drains**

**ADJUSTABLE ACCUTROL (for Large Sump Roof Drains only)**

For more flexibility in controlling flow with heads deeper than 2", Watts Drainage offers the Adjustable Accutrol. The Adjustable Accutrol Weir is designed with a single parabolic opening that can be covered to restrict flow above 2" of head to less than 5 gpm per inch, up to 6" of head. To adjust the flow rate for depths over 2" of head, set the slot in the adjustable upper cone according to the flow rate required. Refer to Table 1 below.  
 Note: Flow rates are directly proportional to the amount of weir opening that is exposed.

**EXAMPLE:**

For example, if the adjustable upper cone is set to cover 1/2 of the weir opening, flow rates above 2" of head will be restricted to 2-1/2 gpm per inch of head.

Therefore, at 3" of head, the flow rate through the Accutrol Weir that has 1/2 the slot exposed will be:  
 [5 gpm (per inch of head) x 2 inches of head ] + 2-1/2 gpm (for the third inch of head) = 12-1/2 gpm.

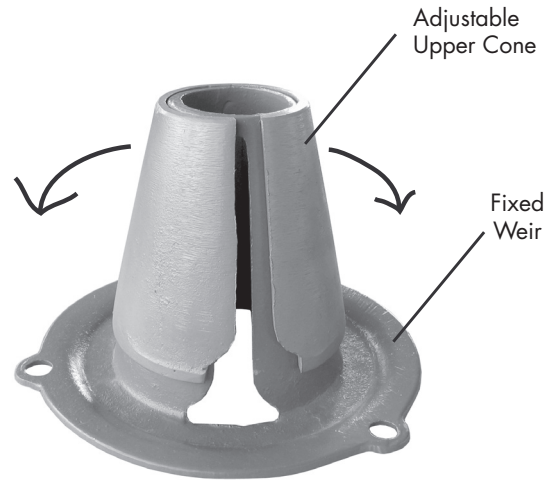
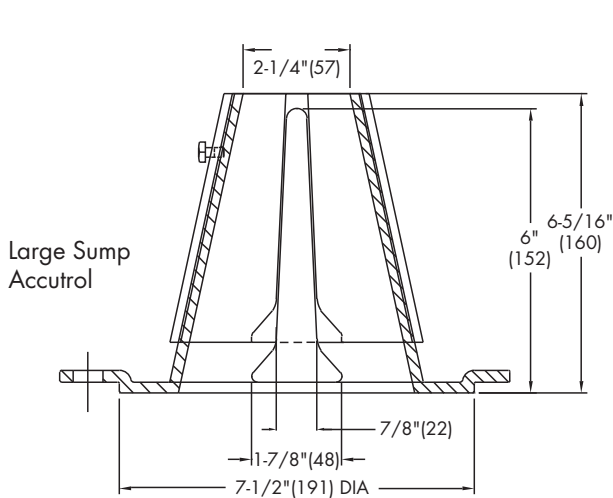

1/2 Weir Opening Exposed Shown Above

TABLE 1. Adjustable Accutrol Flow Rate Settings

Weir Opening Exposed	1"	2"	3"	4"	5"	6"
	Flow Rate (gallons per minute)					
Fully Exposed	5	10	15	20	25	30
3/4	5	10	13.75	17.5	21.25	25
1/2	5	10	12.5	15	17.5	20
1/4	5	10	11.25	12.5	13.75	15
Closed	5	5	5	5	5	5

Job Name \_\_\_\_\_  
 Job Location \_\_\_\_\_  
 Engineer \_\_\_\_\_

Contractor \_\_\_\_\_  
 Contractor's P.O. No. \_\_\_\_\_  
 Representative \_\_\_\_\_

Watts product specifications in U.S. customary units and metric are approximate and are provided for reference only. For precise measurements, please contact Watts Technical Service. Watts reserves the right to change or modify product design, construction, specifications, or materials without prior notice and without incurring any obligation to make such changes and modifications on Watts products previously or subsequently sold.

**USA:** Tel: (800) 338-2581 • Fax: (828) 248-3929 • Watts.com  
**Canada:** Tel: (905) 332-4090 • Fax: (905) 332-7068 • Watts.ca  
**Latin America:** Tel: (52) 81-1001-8600 • Fax: (52) 81-8000-7091 • Watts.com



## Servicing study guidelines for development applications

### 4. Development Servicing Study Checklist

The following section describes the checklist of the required content of servicing studies. It is expected that the proponent will address each one of the following items for the study to be deemed complete and ready for review by City of Ottawa Infrastructure Approvals staff.

The level of required detail in the Servicing Study will increase depending on the type of application. For example, for Official Plan amendments and re-zoning applications, the main issues will be to determine the capacity requirements for the proposed change in land use and confirm this against the existing capacity constraint, and to define the solutions, phasing of works and the financing of works to address the capacity constraint. For subdivisions and site plans, the above will be required with additional detailed information supporting the servicing within the development boundary.

#### 4.1 General Content

- Executive Summary (for larger reports only).
- Date and revision number of the report.
- Location map and plan showing municipal address, boundary, and layout of proposed development.
- Plan showing the site and location of all existing services.
- Development statistics, land use, density, adherence to zoning and official plan, and reference to applicable subwatershed and watershed plans that provide context to which individual developments must adhere.
- Summary of Pre-consultation Meetings with City and other approval agencies.
- Reference and confirm conformance to higher level studies and reports (Master Servicing Studies, Environmental Assessments, Community Design Plans), or in the case where it is not in conformance, the proponent must provide justification and develop a defensible design criteria.
- Statement of objectives and servicing criteria.
- Identification of existing and proposed infrastructure available in the immediate area.
- Identification of Environmentally Significant Areas, watercourses and Municipal Drains potentially impacted by the proposed development (Reference can be made to the Natural Heritage Studies, if available).
- Concept level master grading plan to confirm existing and proposed grades in the development. This is required to confirm the feasibility of proposed stormwater management and drainage, soil removal and fill constraints, and potential impacts to neighbouring properties. This is also required to confirm that the proposed grading will not impede existing major system flow paths.
- Identification of potential impacts of proposed piped services on private services (such as wells and septic fields on adjacent lands) and mitigation required to address potential impacts.
- Proposed phasing of the development, if applicable.

- Reference to geotechnical studies and recommendations concerning servicing.
  
- All preliminary and formal site plan submissions should have the following information:
  - Metric scale
  
  - North arrow (including construction North)
  
  - Key plan
  
  - Name and contact information of applicant and property owner
  
  - Property limits including bearings and dimensions
  
  - Existing and proposed structures and parking areas
  
  - Easements, road widening and rights-of-way
  
  - Adjacent street names

#### **4.2 Development Servicing Report: Water**

- Confirm consistency with Master Servicing Study, if available
- Availability of public infrastructure to service proposed development
- Identification of system constraints
- Identify boundary conditions
- Confirmation of adequate domestic supply and pressure
- Confirmation of adequate fire flow protection and confirmation that fire flow is calculated as per the Fire Underwriter's Survey. Output should show available fire flow at locations throughout the development.
- Provide a check of high pressures. If pressure is found to be high, an assessment is required to confirm the application of pressure reducing valves.
- Definition of phasing constraints. Hydraulic modeling is required to confirm servicing for all defined phases of the project including the ultimate design
- Address reliability requirements such as appropriate location of shut-off valves
- Check on the necessity of a pressure zone boundary modification.
- Reference to water supply analysis to show that major infrastructure is capable of delivering sufficient water for the proposed land use. This includes data that shows that the expected demands under average day, peak hour and fire flow conditions provide water within the required pressure range

- ☒ Description of the proposed water distribution network, including locations of proposed connections to the existing system, provisions for necessary looping, and appurtenances (valves, pressure reducing valves, valve chambers, and fire hydrants) including special metering provisions.
- ☒ Description of off-site required feeder mains, booster pumping stations, and other water infrastructure that will be ultimately required to service proposed development, including financing, interim facilities, and timing of implementation.
- ☒ Confirmation that water demands are calculated based on the City of Ottawa Design Guidelines.
- ☒ Provision of a model schematic showing the boundary conditions locations, streets, parcels, and building locations for reference.

### **4.3 Development Servicing Report: Wastewater**

- ☒ Summary of proposed design criteria (Note: Wet-weather flow criteria should not deviate from the City of Ottawa Sewer Design Guidelines. Monitored flow data from relatively new infrastructure cannot be used to justify capacity requirements for proposed infrastructure).
- ☒ Confirm consistency with Master Servicing Study and/or justifications for deviations.
- ☒ Consideration of local conditions that may contribute to extraneous flows that are higher than the recommended flows in the guidelines. This includes groundwater and soil conditions, and age and condition of sewers.
- ☒ Description of existing sanitary sewer available for discharge of wastewater from proposed development.
- ☒ Verify available capacity in downstream sanitary sewer and/or identification of upgrades necessary to service the proposed development. (Reference can be made to previously completed Master Servicing Study if applicable)
- ☒ Calculations related to dry-weather and wet-weather flow rates from the development in standard MOE sanitary sewer design table (Appendix 'C') format.
- ☒ Description of proposed sewer network including sewers, pumping stations, and forcemains.
- ☒ Discussion of previously identified environmental constraints and impact on servicing (environmental constraints are related to limitations imposed on the development in order to preserve the physical condition of watercourses, vegetation, soil cover, as well as protecting against water quantity and quality).
- ☒ Pumping stations: impacts of proposed development on existing pumping stations or requirements for new pumping station to service development.
- ☒ Forcemain capacity in terms of operational redundancy, surge pressure and maximum flow velocity.
- ☒ Identification and implementation of the emergency overflow from sanitary pumping stations in relation to the hydraulic grade line to protect against basement flooding.
- ☒ Special considerations such as contamination, corrosive environment etc.

#### 4.4 Development Servicing Report: Stormwater Checklist

- Description of drainage outlets and downstream constraints including legality of outlets (i.e. municipal drain, right-of-way, watercourse, or private property)
- Analysis of available capacity in existing public infrastructure.
- A drawing showing the subject lands, its surroundings, the receiving watercourse, existing drainage patterns, and proposed drainage pattern.
- Water quantity control objective (e.g. controlling post-development peak flows to pre-development level for storm events ranging from the 2 or 5 year event (dependent on the receiving sewer design) to 100 year return period); if other objectives are being applied, a rationale must be included with reference to hydrologic analyses of the potentially affected subwatersheds, taking into account long-term cumulative effects.
- Water Quality control objective (basic, normal or enhanced level of protection based on the sensitivities of the receiving watercourse) and storage requirements.
- Description of the stormwater management concept with facility locations and descriptions with references and supporting information.
- Set-back from private sewage disposal systems.
- Watercourse and hazard lands setbacks.
- Record of pre-consultation with the Ontario Ministry of Environment and the Conservation Authority that has jurisdiction on the affected watershed.
- Confirm consistency with sub-watershed and Master Servicing Study, if applicable study exists.
- Storage requirements (complete with calculations) and conveyance capacity for minor events (1:5 year return period) and major events (1:100 year return period).
- Identification of watercourses within the proposed development and how watercourses will be protected, or, if necessary, altered by the proposed development with applicable approvals.
- Calculate pre and post development peak flow rates including a description of existing site conditions and proposed impervious areas and drainage catchments in comparison to existing conditions.
- Any proposed diversion of drainage catchment areas from one outlet to another.
- Proposed minor and major systems including locations and sizes of stormwater trunk sewers, and stormwater management facilities.
- If quantity control is not proposed, demonstration that downstream system has adequate capacity for the post-development flows up to and including the 100 year return period storm event.
- Identification of potential impacts to receiving watercourses
- Identification of municipal drains and related approval requirements.
- Descriptions of how the conveyance and storage capacity will be achieved for the development.
- 100 year flood levels and major flow routing to protect proposed development from flooding for establishing minimum building elevations (MBE) and overall grading.

- Inclusion of hydraulic analysis including hydraulic grade line elevations.
- Description of approach to erosion and sediment control during construction for the protection of receiving watercourse or drainage corridors.
- Identification of floodplains – proponent to obtain relevant floodplain information from the appropriate Conservation Authority. The proponent may be required to delineate floodplain elevations to the satisfaction of the Conservation Authority if such information is not available or if information does not match current conditions.
- Identification of fill constraints related to floodplain and geotechnical investigation.

#### **4.5 Approval and Permit Requirements: Checklist**

The Servicing Study shall provide a list of applicable permits and regulatory approvals necessary for the proposed development as well as the relevant issues affecting each approval. The approval and permitting shall include but not be limited to the following:

- Conservation Authority as the designated approval agency for modification of floodplain, potential impact on fish habitat, proposed works in or adjacent to a watercourse, cut/fill permits and Approval under Lakes and Rivers Improvement Act. The Conservation Authority is not the approval authority for the Lakes and Rivers Improvement Act. Where there are Conservation Authority regulations in place, approval under the Lakes and Rivers Improvement Act is not required, except in cases of dams as defined in the Act.
- Application for Certificate of Approval (CofA) under the Ontario Water Resources Act.
- Changes to Municipal Drains.
- Other permits (National Capital Commission, Parks Canada, Public Works and Government Services Canada, Ministry of Transportation etc.)

#### **4.6 Conclusion Checklist**

- Clearly stated conclusions and recommendations
- Comments received from review agencies including the City of Ottawa and information on how the comments were addressed. Final sign-off from the responsible reviewing agency.
- All draft and final reports shall be signed and stamped by a professional Engineer registered in Ontario



# BEECHWOOD AVENUE

NOTES  
SEWER BR.

- AS - BUILT - DRAWINGS -

THIS SEWER WAS BUILT BY BEAVER CONST.  
 UNDER CONTRACT No. 71-44 FOR 48" STORM SEWER  
 ON BEECHWOOD AVE.  
 FROM 261+60 TO 31+20

WORK START NOV 9/71 DESIGNER E STEWART  
 WORK COMP. MARCH 14/72 INSPECTOR J. WINKLE  
 FIELD MEAS. MARCH 14/72 ACCURACY CERTIFIED  
R. St. Germain INSTRUMENTMAN

DESIGN \_\_\_\_\_ APPROVED \_\_\_\_\_  
 CONSTR. 3473  
 FINAL MEAS. 3473 T.A. H. STUBBS

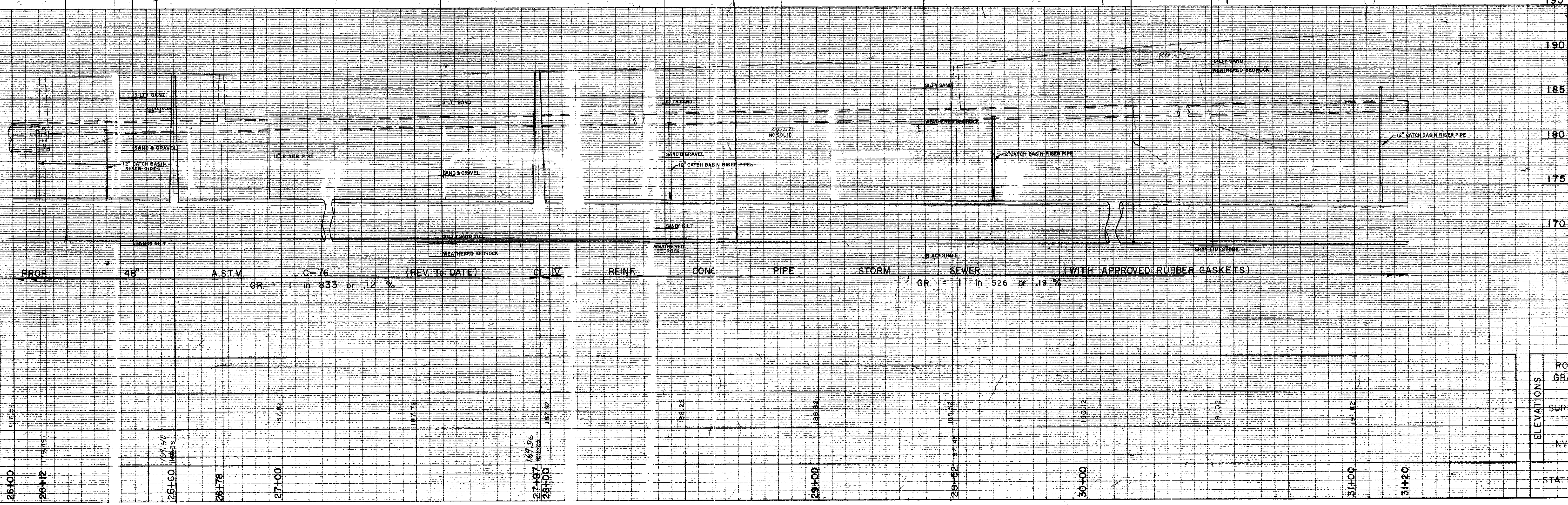
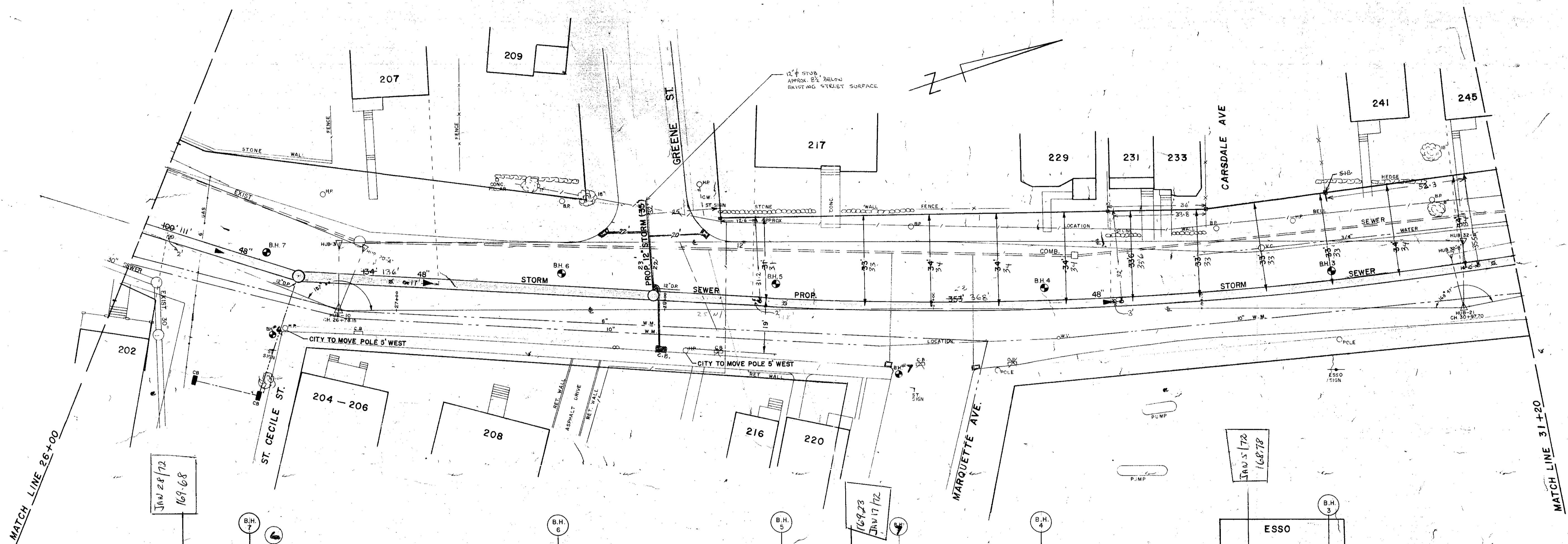

DATE	UTILITY	UTILITY CHECK	REMARKS	CHECK BY
MAY/70	WATER	AS SHOWN		R.P.L.
	GAS	NONE		
	ELECT.			
	HYDRO			

NOTE:  
UTILITIES SHOWN ARE TAKEN FROM BEST AVAILABLE RECORDS. CONTRACTOR IS REQUESTED TO CHECK WITH ALL UTILITY COMPANIES BEFORE DIGGING.

DATE	DESCRIPTION	BY	APPROVED BY
JAN/72	M.H. AT GREENE ST. RELOCATED RISER PIPES RELOCATED.		
DEC/71	6" B.I. WATER MAIN RELOCATED PROP. 48" STORM SEWER RELOCATED		R.P.L.

ELEVATIONS	ROAD GRADE	DESIGNED BY	DATE
	SURFACE		
	INVERT		
STATIONS			

**CITY OF OTTAWA**  
 ENGINEERING DEPARTMENT  
 SEWER BRANCH  
**BEECHWOOD AVENUE**  
 26+00 - 31+20

SCALE: HORIZONTAL = 1" = 20'  
 VERTICAL = 1" = 6'

DATE: APRIL 17/70  
 SURVEY BK. 3493

TH. DOBBIN, P. ENG. CITY ENGINEER

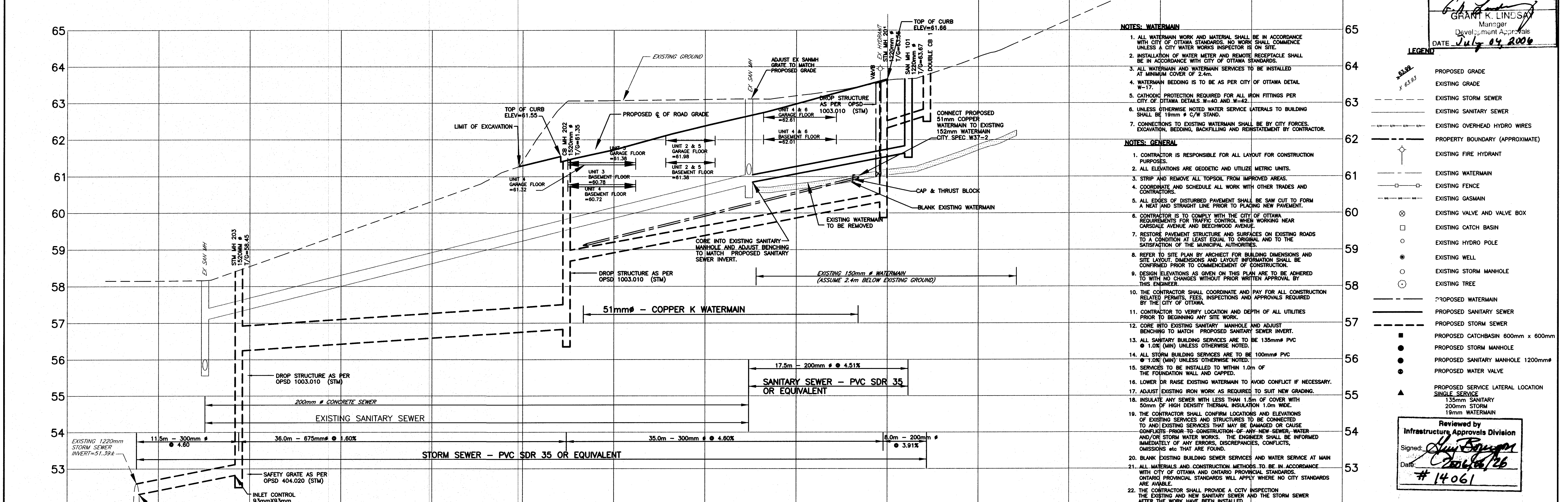
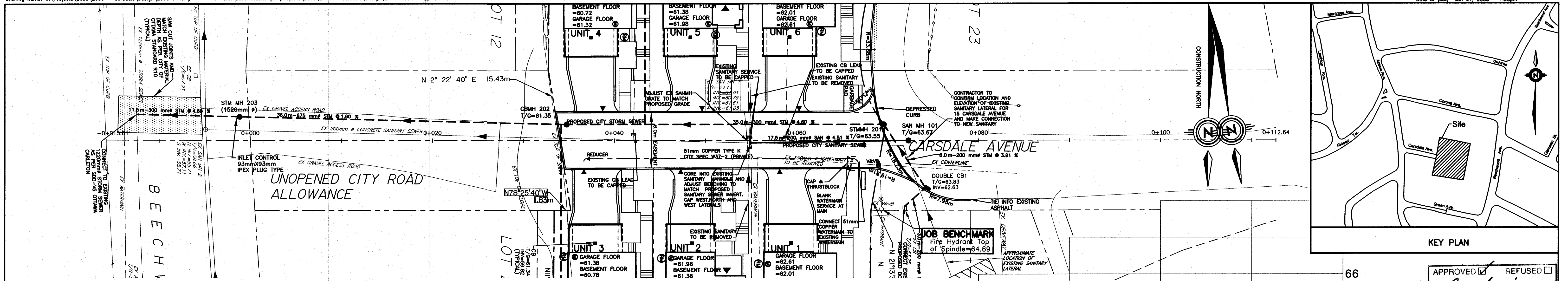

APPROVED  REFUSED   
 GRANT K. LINDSAY  
 Manager  
 Development Approvals  
 DATE July 04, 2006

- LEGEND**
- PROPOSED GRADE
  - - - EXISTING GRADE
  - - - EXISTING STORM SEWER
  - - - EXISTING SANITARY SEWER
  - - - EXISTING OVERHEAD HYDRO WIRES
  - - - PROPERTY BOUNDARY (APPROXIMATE)
  - EXISTING FIRE HYDRANT
  - EXISTING WATERMAIN
  - EXISTING FENCE
  - EXISTING GASMAIN
  - EXISTING VALVE AND VALVE BOX
  - EXISTING CATCH BASIN
  - EXISTING HYDRO POLE
  - EXISTING WELL
  - EXISTING STORM MANHOLE
  - EXISTING TREE
  - - - PROPOSED WATERMAIN
  - - - PROPOSED SANITARY SEWER
  - - - PROPOSED STORM SEWER
  - PROPOSED CATCHBASIN 600mm x 600mm
  - PROPOSED STORM MANHOLE
  - PROPOSED SANITARY MANHOLE 1200mmφ
  - PROPOSED WATER VALVE
  - ▲ PROPOSED SERVICE LATERAL LOCATION SINGLE SERVICE
  - ▲ 135mm SANITARY
  - ▲ 200mm STORM
  - ▲ 19mm WATERMAIN

Reviewed by  
 Infrastructure Approvals Division  
 Signed: *[Signature]*  
 Date: *July 10/06*  
 # 14061

PROPOSED ROAD ¢ ELEVATION	61.28 61.28	61.40	61.55	61.73	62.36	62.88	63.66	64.27	64.66	65.29	65.89	67.25	67.46												
TOP OF WATERMAIN ELEVATION			51.19 51.19	50.33	50.96	60.58	61.12	61.64	62.27	62.89	63.52	64.15	64.78												
STORM SEWER INVERT	51.39± 52.29 W	52.82 53.25 W	56.83 E 56.89 N	59.33	59.96	60.58	61.12	61.64	62.27	62.89	63.52	64.15	64.78												
SANITARY SEWER INVERT			56.83 E 56.89 N	59.33	59.96	60.58	61.12	61.64	62.27	62.89	63.52	64.15	64.78												
EXISTING ¢ R.O.W. ELEVATION	58.15	58.15	58.55	59.43	61.07	62.10	63.17	64.27	64.66	65.29	65.89	67.25	67.46												
CHAINAGE	0+015.8	0+017.4	0+010	0+004.9	0+001.2	0+000	0+010	0+020	0+036.6	0+034.3	0+036.7	0+040	0+050	0+060	0+066.2	0+068.5	0+070.6	0+072.3	0+074.3	0+080	0+084.2	0+090	0+100	0+110	0+112.6

NOTE  
 THE POSITION OF ALL POLE LINES, CONDUITS, WATERMANS,  
 SEWERS AND OTHER UNDERGROUND AND OVERGROUND  
 UTILITIES AND STRUCTURES IS NOT NECESSARILY SHOWN  
 ON THE CONTRACT DRAWINGS, AND WHERE SHOWN, THE  
 ACCURACY OF THE POSITION OF SUCH UTILITIES AND  
 STRUCTURES IS NOT GUARANTEED. BEFORE STARTING WORK  
 DETERMINE THE EXACT LOCATION OF ALL SUCH UTILITIES  
 AND STRUCTURES AND ASSUME ALL LIABILITY FOR DAMAGE TO THEM.

ADDRESS:  
 25 CARSDALE AVENUE  
 OTTAWA, ONTARIO



6.	ISSUED FOR TENDER	JUNE 21/06	UB
5.	REVISED PER CITY COMMENTS	JUNE 16/06	UB
4.	REVISED PER CITY COMMENTS	JUNE 9/06	UB
3.	REVISED PER CITY COMMENTS	MAY 30/06	UB
2.	REVISED PER CITY COMMENTS	MAY 1/06	UB
1.	ISSUED FOR REVIEW	JAN 11/06	UB
No.	REVISION	DATE	BY

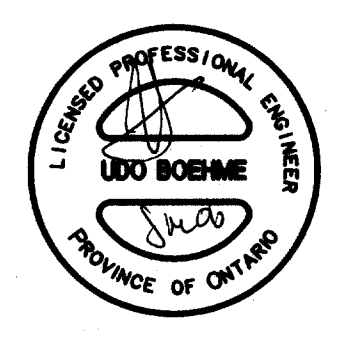

**DME** Ltd.  
 David McManus  
 Engineering Ltd.  
 400 - 30 Cornet Drive  
 Nepean Ontario, K2G 5X8  
 E-mail: mcmanus@dmet.on.ca  
 Ph: 225-1829 Fax: 225-7234

BASEPLAN	DME	SCALE
DESIGN	UB	HORIZ 1:200
CHECKED	UB	VERT 1:50
CAD	JX	0 2 4 6 8
PROJ. MGR.	UB	
APPROVED	UB	

CARSDALE COURT IN ROCKCLIFFE  
 CITY OF OTTAWA  
 PLAN AND PROFILE  
 CARSDALE AVENUE  
 STA. 0-015.8 TO 0+112.6

PROJECT No. 2630  
 SURVEY BY D.M.E.  
 DATE JANUARY 2006  
 DRAWING No. 2630-P1

D07-12-06-0036

## **Appendix D – Drawings**

**C001 - NOTES AND LEGENG SHEET**

**C002 – EXISTING CONDITIONS AND REMOVALS PLAN**

**C100 - SITE SERVICING PLAN**

**C200 - SITE GRADING PLAN**

**C300 - EROSION AND SEDIMENT CONTROL PLAN**

**C400 - STORM DRAINAGE PLAN**

DESCRIPTION	EXISTING	PROPOSED
<b>SITE FEATURES</b>		
PROPERTY LINE	---	---
TOP OF SLOPE	---	---
TERRACING (3:1 TYPICAL)	---	---
☐ DITCH/SWALE AND DIRECTION OF FLOW	---	---
EDGE OF SHOULDER	---	---
EDGE OF PAVEMENT	---	---
☐ ROAD/ALIGNMENT	---	---
CHAINLINK FENCE	---	---
POST AND RAIL FENCE	---	---
SIDEWALK (TYPE AS NOTED ON DRAWINGS)	---	---
BARRIER CURB (SC1.1)	---	---
MOUNTABLE CURB (SC1.3)	---	---
DEPRESSED CURB	---	---
TACTILE WALKING SURFACE INDICATOR "TWSI" (SC7.3)	---	---
GUARDRAIL	---	---
JERSEY BARRIERS	---	---
BUILDING ENTRY/EXIT WITH RISERS	▼xR	▼xR
BUILDING ENTRY/EXIT BARRIER FREE	▼BF	▼BF
BUILDING ENTRY/EXIT OVERHEAD DOOR	▼	▼
POST	⊙ POST	⊙ POST
SIGN	⊙ SIGN	⊙ SIGN
BOLLARD	⊙ BOLL	⊙ BOLL
VEGETATION	⊙	⊙

DESCRIPTION	EXISTING	PROPOSED
<b>UTILITY AND STRUCTURES</b>		
HYDRO (OVERHEAD)	OH	OH
HYDRO	H	H
POWER	P	P
ELECTRICAL	E	E
BELL (OVERHEAD)	OB	OB
BELL	B	B
CABLE (OVERHEAD)	OC	OC
CABLE TV	C	C
FIBRE OPTIC	FO	FO
STREETLIGHT	SL	SL
GASMAIN	G	G
JOINT USE TRENCH - BELL/CABLE TV	BC	BC
JOINT USE TRENCH - HYDRO/BELL/CABLE TV	HBC	HBC
JOINT USE TRENCH - HYDRO/BELL/CABLE TV/GAS	HBCG	HBCG
JOINT USE TRENCH - BELL/CABLE TV/GAS	BCG	BCG
DUCT CROSSING WITH NUMBER AND TYPE OF DUCTS	2H,2C,2B	2H,2C,2B
STREETLIGHT	⊙ SL	⊙ SL
STREETLIGHT DISCONNECT	⊙	⊙
HYDRO TRANSFORMER	⊙	⊙
HYDRO SWITCHING KIOSK	⊙	⊙
HYDRO MANHOLE	⊙	⊙
HYDRO METER	⊙	⊙
UTILITY POLE AND GUY WIRE	⊙-OUP	⊙-OUP
CABLE PEDESTAL	⊙	⊙
BELL PEDESTAL	⊙	⊙
BELL MANHOLE	⊙	⊙
BELL GROUND LEVEL BOX	⊙	⊙
ENDWALL	⊙	⊙
COMMUNITY MAILBOX	⊙	⊙
GAS VALVE	⊙ GV	⊙ GV
GAS METER	⊙	⊙
TRAFFIC MANHOLE	⊙ TMH	⊙ TMH
TRAFFIC HAND HOLE	⊙ HH	⊙ HH
TRAFFIC JOINT USE POLE	⊙ JUP	⊙ JUP
TRAFFIC MAST ARM	⊙ MAF	⊙ MAF
TRAFFIC CONDUIT	---	---

DESCRIPTION	EXISTING	PROPOSED
<b>SERVICES AND STRUCTURES</b>		
SANITARY SEWER	EX 250mm SAN	250mm SAN
COMBINATION SEWER	EX 300mm COMB	300mm COMB
STORM SEWER	EX 375mm STM	375mm STM
STORM SUBDRAIN	EX 150mm SUBDRAIN	150mm SUBDRAIN
STORM CULVERT	EX 600mm CULVERT	600mm CULVERT
SANITARY MANHOLE	EX SAN	SANMH 100
COMBINATION MANHOLE	EX COMB	COMBMH 100
STORM MANHOLE	EX STM	STM MH 200
CATCHBASIN MANHOLE	EX CBMH	CBMH 100
CATCHBASIN	EX CB	CB1
DOUBLE CATCHBASIN	EX DCB	DCB1
CATCHBASIN ELBOW (S30)	EX CBE	CBE
CATCHBASIN TEE (S31)	EX CBT	CBT
CURB INLET CATCHBASIN	EX CICB	CICB 1
DITCH INLET CATCHBASIN	EX DICB	DICB 1
WATERMAIN	200mm WATERMAIN	200mm WATERMAIN
IRRIGATION	IR	IR
VALVE AND VALVE BOX	V&VB	V&VB
VALVE AND VALVE CHAMBER	V&VC	V&VC
FIRE HYDRANT	FH	FH
SIAMESE CONNECTION	SC	SC
WATER METER	M	M
REMOTE WATER METER	RM	RM
45° BEND	~45°	~45°
22.5° BEND	~22°	~22°
11.25° BEND	~11°	~11°
TEE	~200X150 TEE	~200X150 TEE
REDUCER	~200X100 RED	~200X100 RED
CROSS	~300X200 CROSS	~300X200 CROSS
CURB STOP	CS	CS
WATER WELL	⊙	⊙

DESCRIPTION	EXISTING	PROPOSED
<b>GRADING</b>		
GROUND ELEVATION	X 100.00	X 100.00
SWALE ELEVATION	X 100.00(S)	X 100.00(S)
TOP OF GRATE ELEVATION	T/G=100.00	T/G=100.00
TOP OF WALL ELEVATION	X 100.00 T/W	X 100.00 T/W
BOTTOM OF WALL ELEVATION	X 100.00 B/W	X 100.00 B/W
FINISHED FLOOR ELEVATION	FF=100.00	FF=100.00
TOP OF FOUNDATION ELEVATION	TF=100.00	TF=100.00
BASEMENT FLOOR ELEVATION	BF=100.00	BF=100.00
PARKING LEVEL ELEVATION	P1=100.00	P1=100.00
UNDERSIDE OF FOOTING ELEVATION	USF=100.00	USF=100.00
ORIGINAL GROUND ELEVATION	OG=100.00	OG=100.00
TOP OF ROCK ELEVATION	T/ROCK=100.00	T/ROCK=100.00
CONTOUR LINES	100.00	100.00
SLOPE AND DIRECTION OF FLOW	2.0%	2.0%
OVERLAND FLOW ROUTE ONSITE	---	---
OVERLAND FLOW ROUTE EXTERNAL	---	---

DESCRIPTION	EXISTING	PROPOSED
<b>STORMWATER MANAGEMENT</b>		
STORM DRAINAGE AREA BOUNDARY	---	---
STORM DRAINAGE AREA NUMBER	1	1
STORM DRAINAGE AREA IN HECTARES	0.06	0.06
RUN-OFF COEFFICIENT	0.75	0.75
5 YEAR PONDING AREA	5 YR	5 YR
100 YEAR PONDING AREA	100 YR	100 YR
<b>GEOTECHNICAL</b>		
BOREHOLE	⊙ BH	⊙ BH
TEST PIT	⊙ TP	⊙ TP
COREHOLE	⊙ CH	⊙ CH
PIEZOMETER	⊙ PIZ	⊙ PIZ
MONITORING WELL	⊙ MW	⊙ MW

DESCRIPTION	EXISTING	PROPOSED
<b>MISCELLANEOUS</b>		
REMOVED	---	---
RELOCATED	---	---
ADJUSTED	---	---
LIGHT DUTY PAVEMENT	---	---
HEAVY DUTY PAVEMENT	---	---
ROAD REINSTATEMENT AS PER CITY STANDARD R10	---	---
RIP-RAP AS PER OPSD B10.010	---	---
LANDSCAPE REINSTATEMENT	---	---
MONOLITHIC CURB INSTALLATION	---	---

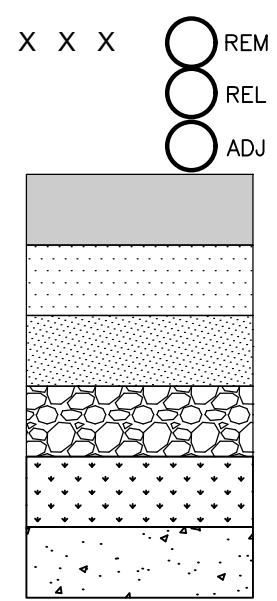

- GENERAL NOTES**
- ALL WORKS AND MATERIALS SHALL CONFORM TO THE LATEST REVISIONS OF THE STANDARDS AND SPECIFICATIONS OF THE CITY OF OTTAWA, ONTARIO PROVINCIAL STANDARD DRAWINGS (OPSD) AND SPECIFICATIONS (OPSS), WHERE APPLICABLE.
  - THE LOCATION OF UTILITIES IS APPROXIMATE ONLY, AND THE EXACT LOCATION SHOULD BE DETERMINED BY CONSULTING THE MUNICIPAL AUTHORITIES AND UTILITY COMPANIES CONCERNED. THE CONTRACTOR IS RESPONSIBLE TO PROVIDE THE LOCATION AND STATUS OF UTILITIES AND SHALL BE RESPONSIBLE FOR ADEQUATE PROTECTION OF PLANT AND EQUIPMENT FROM DAMAGE. THE CONTRACTOR SHALL BE RESPONSIBLE FOR REPAIR OR REPLACEMENT OF ANY SERVICES OR UTILITIES DISTURBED DURING CONSTRUCTION, TO THE SATISFACTION OF THE AUTHORITY HAVING JURISDICTION.
  - THE CONTRACTOR SHALL VERIFY THE LOCATION AND ELEVATION OF EXISTING SERVICES PRIOR TO ANY CONSTRUCTION. THE CONTRACTOR SHALL CONFIRM LOCATIONS AND ELEVATIONS OF EXISTING SERVICES AND STRUCTURES TO BE CONNECTED TO AND EXISTING SERVICES THAT MAY BE DAMAGED OR CAUSE CONFLICTS PRIOR TO CONSTRUCTION OF ANY NEW SEWER, WATER AND/OR STORM WATER WORKS. ALL DIMENSIONS SHALL BE CHECKED AND VERIFIED IN THE FIELD BY THE CONTRACTOR PRIOR TO THE START OF CONSTRUCTION. ANY DISCREPANCIES, INTERPRETATIONS, CHANGES AND ADDITIONS TO THESE DRAWINGS MUST BE BROUGHT TO THE ATTENTION OF THE ENGINEER, WHEN NOTED AND BEFORE PROCEEDING WITH CONSTRUCTION WORKS. DO NOT CONTINUE CONSTRUCTION IN AREAS WHERE DISCREPANCIES APPEAR UNTIL SUCH DISCREPANCIES HAVE BEEN RESOLVED.
  - ALL ELEVATIONS ARE GEODETIC AND UTILIZE METRIC UNITS. ALL DIMENSIONS ARE IN METERS UNLESS OTHERWISE SPECIFIED. ALL DRAWINGS SHOULD NOT BE SCALED BY THE CONTRACTOR. ANY MISSING OR QUESTIONABLE DIMENSIONS ARE TO BE CONFIRMED WITH THE ENGINEER IN WRITING.
  - THE CONTRACTOR SHALL BE RESPONSIBLE FOR OBTAINING ALL PERMITS REQUIRED AND BEAR COST OF THE SAME.
  - ALL WORK SHALL BE COMPLETED IN ACCORDANCE WITH THE "OCCUPATIONAL HEALTH AND SAFETY ACT AND REGULATIONS FOR CONSTRUCTION PROJECTS", THE GENERAL CONTRACTOR SHALL BE DEEMED TO BE THE CONSTRUCTOR AS DEFINED IN THE ACT.
  - CONTRACTOR SHALL BE RESPONSIBLE FOR ALL EXCAVATION, BACKFILL AND REINSTATEMENT OF ALL AREAS DISTURBED DURING CONSTRUCTION TO THE SATISFACTION OF THE ENGINEER, THE CITY OF OTTAWA AND THE AUTHORITY HAVING JURISDICTION.
  - ANY AREAS BEYOND THE LIMIT OF THE SITE DISTURBED DURING CONSTRUCTION SHALL BE RESTORED TO ORIGINAL CONDITION OR BETTER TO THE SATISFACTION OF THE AUTHORITY HAVING JURISDICTION AT THE CONTRACTOR'S EXPENSE.
  - THE CONTRACTOR SHALL COMPLY WITH THE CITY OF OTTAWA REQUIREMENTS FOR TRAFFIC CONTROL WHEN WORKING ON CITY STREETS. ALL CONSTRUCTION SIGNAGE MUST CONFORM TO THE M.T.O. MANUAL OF UNIFORM TRAFFIC CONTROL DEVICES (LATEST AMENDMENT).
  - THE SUPPORT OF ALL UTILITIES SHALL BE IN ACCORDANCE WITH THE REQUIREMENTS OF THE AUTHORITY HAVING JURISDICTION.
  - THERE WILL BE NO SUBSTITUTION OF MATERIALS UNLESS WRITTEN APPROVAL BY THE ENGINEER HAS BEEN OBTAINED.
  - EXCESS EXCAVATED MATERIAL SHALL BE REMOVED FROM THE SITE.
  - THE SITE LAYOUT IS THE RESPONSIBILITY OF THE CONTRACTOR. AS-BUILT SITE SERVICING & GRADING DRAWINGS SHALL BE MAINTAINED ON SITE BY THE CONTRACTOR.
  - ALL EDGES OF DISTURBED PAVEMENT SHALL BE SAW CUT TO FORM A NEAT AND STRAIGHT LINE PRIOR TO PLACING NEW PAVEMENT.
  - FOR GEOTECHNICAL INFORMATION REFER TO GEOTECHNICAL INVESTIGATION REPORT PREPARED BY EXP SERVICES INC DATED MARCH, 2022, PROJECT NO. OTT-00238207-C0
  - THE CONTRACTOR SHALL APPRAISE HIS/HER SELF OF ALL SURFACE AND SUBSURFACE CONDITIONS TO BE ENCOUNTERED AND SHALL CARRY OUT THEIR OWN TEST PITS AS REQUIRED TO MAKE THEIR OWN INDEPENDENT ASSESSMENT OF GROUND CONDITIONS. THE CONTRACTOR SHALL NOT MAKE ANY CLAIM FOR ANY EXTRA COST DUE TO ANY SUCH GROUND CONDITIONS VARYING FROM THOSE ANTICIPATED BY THE CONTRACTOR.
  - DO NOT CONSTRUCT USING DRAWINGS THAT ARE NOT MARKED "ISSUED FOR CONSTRUCTION".
  - FOR TOPOGRAPHICAL INFORMATION REFER TO PLAN PREPARED BY ANIS, O'SULLIVAN, VOLLEBECK SURVEYING LTD. DATED JUNE 16, 2017.
  - CIVIL DRAWINGS TO BE READ IN CONJUNCTION WITH ARCHITECTURAL, MECHANICAL, ELECTRICAL, STRUCTURAL, LANDSCAPE AND LEGAL DRAWINGS.
  - A SCHEMATIC DIAGRAM INCLUDING PROPOSED ELEVATIONS, DETAILS OF PROPOSED FOUNDATION DRAINS, STORM LATERAL, AND INTERNAL MECHANICAL PIPING WILL BE PREPARED BY THE MECHANICAL CONSULTANT PRIOR TO REGISTRATION.
  - THE SIDES OF THE EXCAVATION FOR UTILITY TRENCHES AND SUBSURFACE BASEMENT WALLS THAT EXTEND INTO THE SHALE BEDROCK BELOW THE GROUND WATER SHOULD BE SPRAYED WITH GUNNITE TO PREVENT DETERIORATION AND HEAVE OF THE SHALE BEDROCK. FOR UNDERGROUND SERVICE, AN ALTERNATIVE TO GUNNITE IS TO BACKFILL THE PORTION OF THE TRENCHES IN BEDROCK BELOW THE GROUNDWATER LEVEL USING CLAY OR CONCRETE.
- SANITARY SEWER NOTES:**
- ALL SANITARY SEWER MATERIALS AND INSTALLATION SHALL CONFORM TO THE LATEST REVISIONS OF THE STANDARDS AND SPECIFICATIONS OF THE CITY OF OTTAWA, ONTARIO PROVINCIAL STANDARD DRAWINGS (OPSD) AND SPECIFICATIONS (OPSS).
  - ALL SANITARY SEWERS SHALL BE PVC DR 35, iPEX "RING-TITE" (OR EQUIVALENT), AS PER CSA STANDARD B182.2 OR LATEST AMENDMENT, UNLESS OTHERWISE NOTED.
  - SANITARY SEWER TRENCH AND BEDDING SHALL BE AS PER CITY OF OTTAWA STD. S6 AND S7, CLASS "B" BEDDING UNLESS OTHERWISE NOTED. BEDDING DEPTH AS PER GEOTECHNICAL STUDY.
  - THE CONTRACTOR SHALL CONDUCT CCTV INSPECTION OF ALL NEWLY INSTALLED SANITARY SEWERS AND EXISTING SEWERS CONNECTED TO. THE TEST SHALL BE PERFORMED IMMEDIATELY AFTER SEWERS INSTALLED.
- STORM SEWER NOTES:**
- ALL STORM SEWER MATERIALS AND INSTALLATION SHALL CONFORM TO THE LATEST REVISIONS OF THE STANDARDS AND SPECIFICATIONS OF THE CITY OF OTTAWA, ONTARIO PROVINCIAL STANDARD DRAWINGS (OPSD) AND SPECIFICATIONS (OPSS).
  - ALL PVC STORM SEWERS ARE TO BE SDR 35 APPROVED PER C.S.A. B182.2 OR LATEST AMENDMENT, UNLESS OTHERWISE SPECIFIED.
  - THE CONTRACTOR SHALL CONSTRUCT FLEXIBLE STORM SEWERS IN ACCORDANCE WITH OPSD 802.010 AND 802.013. DURING CONSTRUCTION THE CONTRACTOR SHALL PROTECT THE PIPES FROM HEAVY CONSTRUCTION EQUIPMENT. BEDDING AND BACKFILL SHALL BE COMPACTED TO A MINIMUM OF 95% SPMD0.
  - SEWER BEDDING DEPTH AS PER GEOTECHNICAL STUDY.
  - THE CONTRACTOR SHALL BE RESPONSIBLE FOR OBTAINING ALL PERMITS REQUIRED AND BEAR COST OF THE SAME.
  - ALL WORK SHALL BE COMPLETED IN ACCORDANCE WITH THE "OCCUPATIONAL HEALTH AND SAFETY ACT AND REGULATIONS FOR CONSTRUCTION PROJECTS", THE GENERAL CONTRACTOR SHALL BE DEEMED TO BE THE CONSTRUCTOR AS DEFINED IN THE ACT.
  - CONTRACTOR SHALL BE RESPONSIBLE FOR ALL EXCAVATION, BACKFILL AND REINSTATEMENT OF ALL AREAS DISTURBED DURING CONSTRUCTION TO THE SATISFACTION OF THE ENGINEER, THE CITY OF OTTAWA AND THE AUTHORITY HAVING JURISDICTION.
  - ANY AREAS BEYOND THE LIMIT OF THE SITE DISTURBED DURING CONSTRUCTION SHALL BE RESTORED TO ORIGINAL CONDITION OR BETTER TO THE SATISFACTION OF THE AUTHORITY HAVING JURISDICTION AT THE CONTRACTOR'S EXPENSE.
  - THE CONTRACTOR SHALL COMPLY WITH THE CITY OF OTTAWA REQUIREMENTS FOR TRAFFIC CONTROL WHEN WORKING ON CITY STREETS. ALL CONSTRUCTION SIGNAGE MUST CONFORM TO THE M.T.O. MANUAL OF UNIFORM TRAFFIC CONTROL DEVICES (LATEST AMENDMENT).
  - THE SUPPORT OF ALL UTILITIES SHALL BE IN ACCORDANCE WITH THE REQUIREMENTS OF THE AUTHORITY HAVING JURISDICTION.
  - THERE WILL BE NO SUBSTITUTION OF MATERIALS UNLESS WRITTEN APPROVAL BY THE ENGINEER HAS BEEN OBTAINED.
  - EXCESS EXCAVATED MATERIAL SHALL BE REMOVED FROM THE SITE.
  - THE SITE LAYOUT IS THE RESPONSIBILITY OF THE CONTRACTOR. AS-BUILT SITE SERVICING & GRADING DRAWINGS SHALL BE MAINTAINED ON SITE BY THE CONTRACTOR.
  - ALL EDGES OF DISTURBED PAVEMENT SHALL BE SAW CUT TO FORM A NEAT AND STRAIGHT LINE PRIOR TO PLACING NEW PAVEMENT.
  - FOR GEOTECHNICAL INFORMATION REFER TO GEOTECHNICAL INVESTIGATION REPORT PREPARED BY EXP SERVICES INC DATED MARCH, 2022, PROJECT NO. OTT-00238207-C0
  - THE CONTRACTOR SHALL APPRAISE HIS/HER SELF OF ALL SURFACE AND SUBSURFACE CONDITIONS TO BE ENCOUNTERED AND SHALL CARRY OUT THEIR OWN TEST PITS AS REQUIRED TO MAKE THEIR OWN INDEPENDENT ASSESSMENT OF GROUND CONDITIONS. THE CONTRACTOR SHALL NOT MAKE ANY CLAIM FOR ANY EXTRA COST DUE TO ANY SUCH GROUND CONDITIONS VARYING FROM THOSE ANTICIPATED BY THE CONTRACTOR.
  - DO NOT CONSTRUCT USING DRAWINGS THAT ARE NOT MARKED "ISSUED FOR CONSTRUCTION".
  - FOR TOPOGRAPHICAL INFORMATION REFER TO PLAN PREPARED BY ANIS, O'SULLIVAN, VOLLEBECK SURVEYING LTD. DATED JUNE 16, 2017.
  - CIVIL DRAWINGS TO BE READ IN CONJUNCTION WITH ARCHITECTURAL, MECHANICAL, ELECTRICAL, STRUCTURAL, LANDSCAPE AND LEGAL DRAWINGS.
  - A SCHEMATIC DIAGRAM INCLUDING PROPOSED ELEVATIONS, DETAILS OF PROPOSED FOUNDATION DRAINS, STORM LATERAL, AND INTERNAL MECHANICAL PIPING WILL BE PREPARED BY THE MECHANICAL CONSULTANT PRIOR TO REGISTRATION.
  - THE SIDES OF THE EXCAVATION FOR UTILITY TRENCHES AND SUBSURFACE BASEMENT WALLS THAT EXTEND INTO THE SHALE BEDROCK BELOW THE GROUND WATER SHOULD BE SPRAYED WITH GUNNITE TO PREVENT DETERIORATION AND HEAVE OF THE SHALE BEDROCK. FOR UNDERGROUND SERVICE, AN ALTERNATIVE TO GUNNITE IS TO BACKFILL THE PORTION OF THE TRENCHES IN BEDROCK BELOW THE GROUNDWATER LEVEL USING CLAY OR CONCRETE.
- WATERMAIN NOTES:**
- ALL WATERMAIN MATERIALS AND INSTALLATION SHALL CONFORM TO THE LATEST REVISIONS OF THE STANDARDS AND SPECIFICATIONS OF THE CITY OF OTTAWA, ONTARIO PROVINCIAL STANDARD DRAWINGS (OPSD) AND SPECIFICATIONS (OPSS).
  - NO WORK SHALL COMMENCE UNLESS A CITY WATER WORKS INSPECTOR IS ON SITE. WATERMAIN CONNECTIONS BY CITY OF OTTAWA FORCES WITH ALL EXCAVATION BACKFILL AND ROAD REINSTATEMENT BY CONTRACTOR.
  - WATERMANS TRENCH AND BEDDING SHALL BE IN ACCORDANCE WITH CITY OF OTTAWA STANDARD W17, UNLESS OTHERWISE SPECIFIED. BEDDING AND COVER MATERIAL SHALL BE SPECIFIED BY PROJECT GEOTECHNICAL ENGINEER.
  - CATHODIC PROTECTION IS REQUIRED ON ALL METALLIC FITTINGS AS PER CITY OF OTTAWA STD. W40. ALL ANODES SHALL BE A 2-24-48 AS PER CITY OF OTTAWA STD. W44.
  - ALL WATERMANS TO BE INSTALLED AT MINIMUM COVER OF 2.4m.
  - IF WATERMAIN MUST BE DEFLECTED TO MEET ALIGNMENT, ENSURE THAT THE AMOUNT OF DEFLECTION USED IS LESS THAN HALF THAT RECOMMENDED BY THE MANUFACTURER.
  - DISINFECTION AND TESTING OF WATERMAIN TO BE IN ACCORDANCE WITH CITY OF OTTAWA STANDARDS.
  - WATER METER TO BE INSTALLED TO BE COORDINATED WITH MECHANICAL.
  - INSULATION FOR WATERMAIN CROSSING OVER AND BELOW SEWER SHALL BE IN ACCORDANCE WITH CITY OF OTTAWA STD. W25.2 AND W25, RESPECTIVELY, WHERE WATERMAIN COVER IS LESS THAN 2.4m.
  - PRESSURE REDUCING MEASURES REQUIRED FOR INTERNAL WATER SYSTEMS.
- ROAD NOTES:**
- PAVEMENT REINSTATEMENT FOR SERVICE AND UTILITY CUTS SHALL BE IN ACCORDANCE WITH CITY OF OTTAWA STD. R10 AND OPSD 509.010, OPSS 310.
  - GRANULAR "A" SHALL BE PLACED TO A MINIMUM THICKNESS OF 300mm AROUND ALL STRUCTURES WITHIN PAVEMENT AREA.
  - ALL GRANULAR FOR ROADS SHALL BE COMPACTED TO A MINIMUM OF 95% STANDARD PROCTOR MAXIMUM DRY DENSITY.
  - PAVEMENT STRUCTURE:**  
SITE ACCESS DRIVEWAYS:  
- 40mm SUPERPAVE 12.5 ASPHALTIC CONCRETE  
- 50mm SUPERPAVE 19.0 ASPHALTIC CONCRETE  
- 150mm GRANULAR "A" CRUSHED LIMESTONE (OPSS 1010)  
- 400mm GRANULAR "B" TYPE II (OPSS 1010)
- BEECHWOOD AVENUE:**
- 40mm SUPERPAVE 12.5 ASPHALTIC CONCRETE
  - 50mm SUPERPAVE 19.0 ASPHALTIC CONCRETE
  - 150mm GRANULAR "A" CRUSHED LIMESTONE (OPSS 1010)
  - 400mm GRANULAR "B" TYPE II (OPSS 1010)

File Name: \\exp\projects\229-247\229-247-001.dwg  
 User: jsmith  
 Date: 22/03/22 11:43:05 AM  
 Plot: 229-247-001.dwg  
 Plot Date: 22/03/22 11:43:05 AM  
 Plot Scale: 1:1  
 Plot Orientation: Landscape  
 Plot Range: All  
 Plot Style: exp.ctb  
 Plot Color: Black  
 Plot Lineweight: 0.5  
 Plot Linetype: Solid  
 Plot Font: Arial, 10  
 Plot Title: 229-247-001.dwg  
 Plot Sheet: 1 of 1  
 Plot Status: Success

**CAUTION**  
 THE POSITION OF ALL POLE LINES, CONDUITS, WATERMANS, SEWERS AND OTHER UNDERGROUND AND OVERGROUND UTILITIES AND STRUCTURES IS NOT NECESSARILY SHOWN ON THE CONTRACT DRAWINGS, AND WHERE SHOWN, THE ACCURACY OF THE POSITION OF SUCH UTILITIES AND STRUCTURES IS NOT GUARANTEED. BEFORE STARTING WORK, DETERMINE THE EXACT LOCATION OF ALL SUCH UTILITIES AND STRUCTURES AND ASSUME ALL LIABILITY FOR DAMAGE TO THEM.

REV	REVISION DESCRIPTION	DATE	BY	APPRO
2	ISSUED FOR CITY REVIEW	22/03/22	AC	BMT
1	ISSUED FOR SITE PLAN CONTROL	15/12/20	SK	BMT

SCALE	DESIGNED BY	REVIEWED BY

CLIENT	BASE PLAN	PROJECT
229 BEECHWOOD HOLDINGS INC. AND 241 BEECHWOOD HOLDINGS INC. C/O BINTEE DEV INC. BINTEE DEV INC. 226 ARGYLE Ave., OTTAWA, ON, K2P 1B9	SK DESIGN: JLF/ARO CHECKED: BMT	229-247 BEECHWOOD OTTAWA, ON
exp Services Inc. 1-813-688-1889   1-813-225-7330 1000 Wellington St. Unit 100 Ottawa, ON K2B 8R6 Canada www.exp.com	SK PROJECT MANAGER: BMT APPROVED: BMT	DATE: DEC 2020 DRAWING NO: C001

NOTES AND LEGEND SHEET



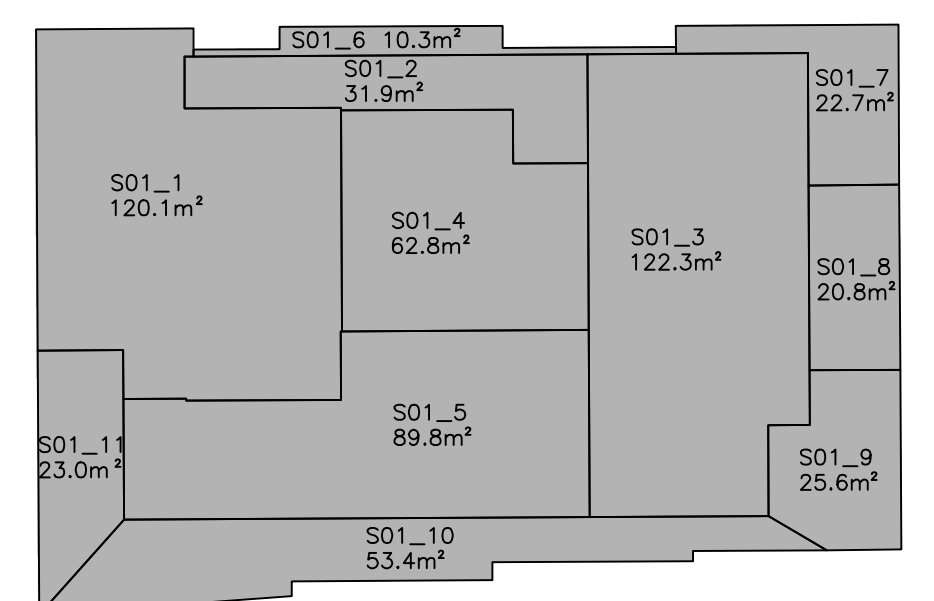
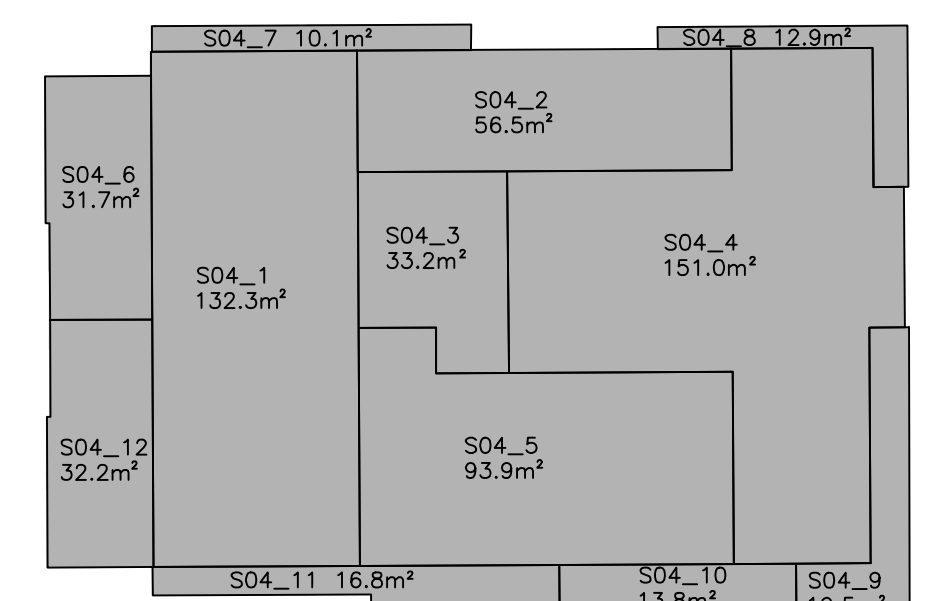
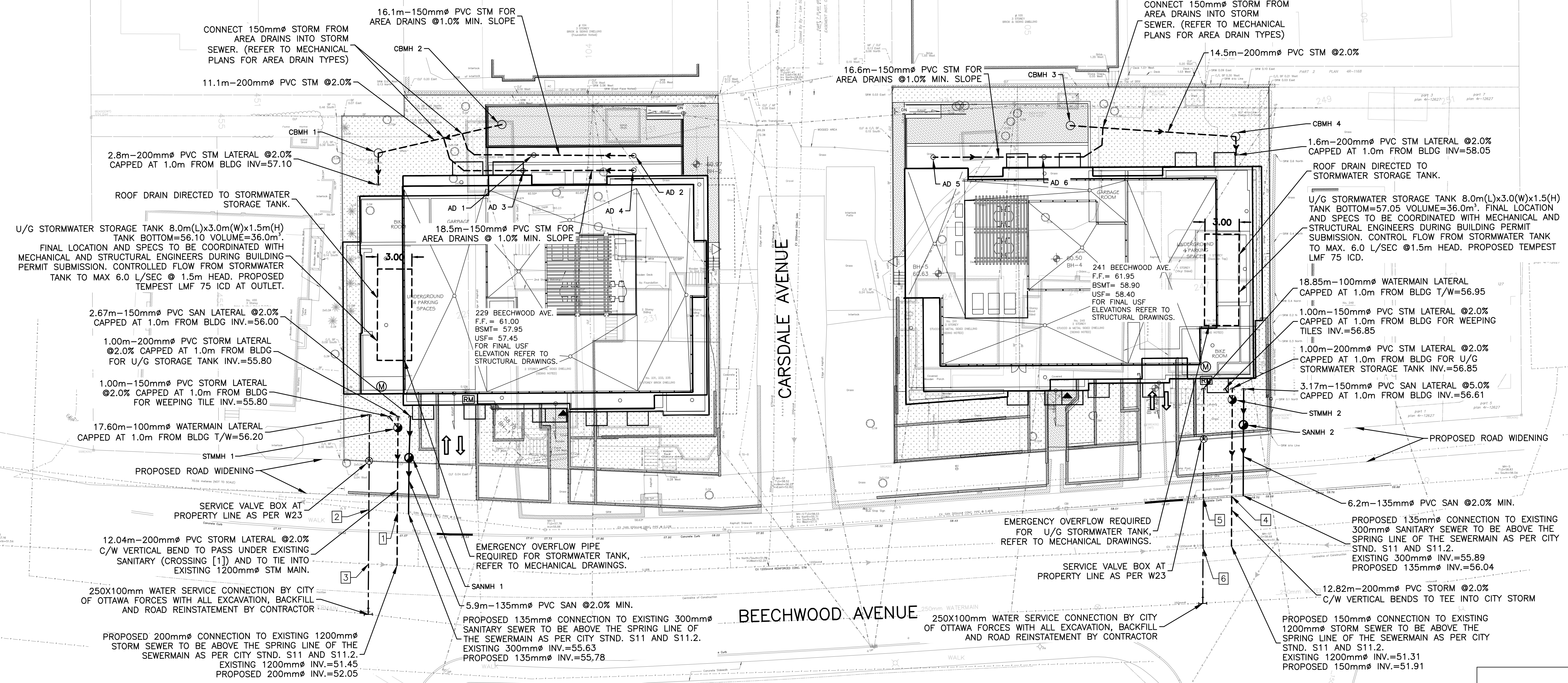
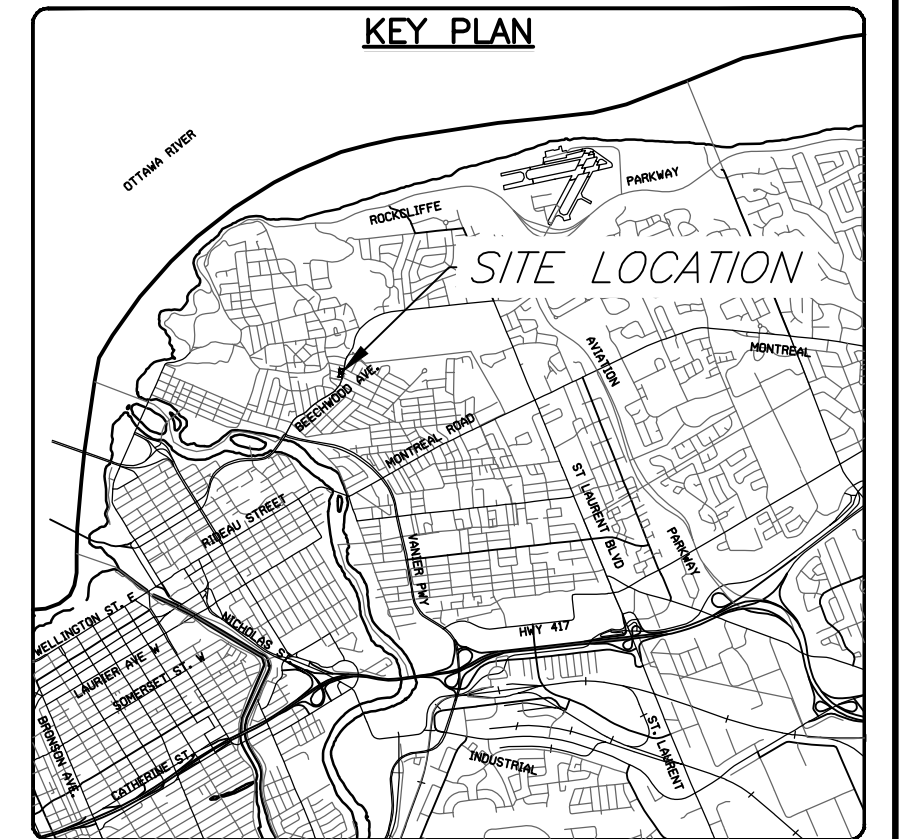
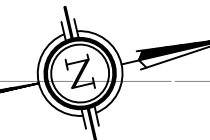

LOCATION	FINISHED GRADE (m)	SANITARY SEWER			STORM SEWER			WATERMAIN			CLEARANCES (mm)
		INV ELEV (m)	DIA (mm)	OBV ELEV (m)	INV ELEV (m)	DIA (mm)	OBV ELEV (m)	INV ELEV (m)	DIA (mm)	OBV ELEV (m)	
1	57.69	55.63	300	55.93	54.93	200	55.13				500
2	57.68	55.62	300	55.92			54.87	100	54.97		650
3	57.50				51.89	1200	53.09	55.25	100	55.35	2160
4	58.65	55.87	300	56.17	56.63	200	56.83				460
5	58.67	55.88	300	56.18			56.50	100	56.60		320
6	58.60				51.31	1200	52.51	56.45	100	56.55	3940

STATION	DESCRIPTION	GROUND ELEVATION (m)	TOP OF WATERMAIN. ELEV (m)	
			PROPOSED (m)	AS-BUILT (m)
<b>229 Beechwood</b>				
0+000	250x100 TEE	57.50	55.40	
0+07.7	45° VERTICAL BEND	57.67	55.27	
0+08.0	45° VERTICAL BEND	57.67	54.97	
0+10.3	45° VERTICAL BEND	58.15	54.97	
0+11.1	45° VERTICAL BEND	58.17	55.77	
0+013.4	VALVE AND VALVE BOX	58.37	55.97	
0+017.5	CAP - 1m FROM BUILDING	58.60	56.20	
<b>241 Beechwood</b>				
0+000	250x100 TEE	58.60	56.50	
0+014.4	VALVE AND VALVE BOX	59.05	56.65	
0+018.8	CAP - 1m FROM BUILDING	59.73	56.95	

STRUCTURE NUMBER	TYPE	LID ELEV (m)	INVERT IN (m) and DIA (mm)	INVERT OUT (m) and DIA (mm)	STRUCTURE			Comment
					SIZE	REFERENCE	COVER	
CBMH 1	STORM	59.26	57.220 (200)	57.160 (200)	1200 DIA	OPSD 701.010	Ottawa S25 Ottawa S28.1	
CBMH 2	STORM	60.67		57.440 (200)	1200 DIA	OPSD 701.010	Ottawa S25 Ottawa S28.1	
CBMH 3	STORM	60.69		58.430 (200)	1200 DIA	OPSD 701.010	Ottawa S25 Ottawa S28.1	
CBMH 4	STORM	60.65	58.140 (200)	58.080 (200)	1200 DIA	OPSD 701.010	Ottawa S25 Ottawa S28.1	
STMMH 1	STORM	58.44	55.78 (W) (200) 55.78 (SW) (150)	55.750 (200)	1200 DIA	OPSD 701.010	Ottawa S25 Ottawa S24.1	Lateral to stormwater storage tank Lateral for weeping tile connection
STMMH 2	STORM	59.70	56.83 (W) (200) 56.83 (SW) (150)	56.800 (200)	1200 DIA	OPSD 701.010	Ottawa S25 Ottawa S24.1	Lateral to stormwater storage tank Lateral for weeping tile connection
SANMH 1	SANITARY	58.32	55.930 (150)	55.900 (135)	1200 DIA	OPSD 705.010	Ottawa S25 Ottawa S24	
SANMH 2	SANITARY	59.67	56.450 (150)	56.400 (135)	1200 DIA	OPSD 705.010	Ottawa S25 Ottawa S24	

Control Location	Post-Dev Area No.	Max Flow (L/sec)	Max Head (m)	Type	Model
229 Beechwood U/G Stormwater Tank	S04	6.00	1.5	TEMPEST	LMF75
241 Beechwood U/G Stormwater Tank	S01	6.00	1.5	TEMPEST	LMF75

AREA #	100 YEAR PONDING DEPTH (mm)	WEIR TYPE	NO. OF WEIRS PER DRAIN	WEIR POSITION
S04_1	110	WATTS ACCUTROL	1	6-FULL
S04_2	98	WATTS ACCUTROL	1	6-FULL
S04_3	95	WATTS ACCUTROL	1	3-1/4 OPEN
S04_4	125	WATTS ACCUTROL	1	4-1/2 OPEN
S04_5	120	WATTS ACCUTROL	0	3-1/4 OPEN
S04_6	0	NONE	NO WEIR	1-NONE
S04_7	0	NONE	NO WEIR	1-NONE
S04_8	0	NONE	NO WEIR	1-NONE
S04_9	0	NONE	NO WEIR	1-NONE
S04_10	0	NONE	NO WEIR	1-NONE
S04_11	0	NONE	NO WEIR	1-NONE
S04_12	0	NONE	NO WEIR	1-NONE

AREA #	100 YEAR PONDING DEPTH (mm)	WEIR TYPE	NO. OF WEIRS PER DRAIN	WEIR POSITION
S01_1	113	WATTS ACCUTROL	1	6-FULL
S01_2	82	WATTS ACCUTROL	1	6-FULL
S01_3	124	WATTS ACCUTROL	1	3-1/4 OPEN
S01_4	107	WATTS ACCUTROL	1	4-1/2 OPEN
S01_5	119	WATTS ACCUTROL	1	3-1/4 OPEN
S01_6	0	NONE	NO WEIR	1-NONE
S01_7	0	NONE	NO WEIR	1-NONE
S01_8	0	NONE	NO WEIR	1-NONE
S01_9	0	NONE	NO WEIR	1-NONE
S01_10	0	NONE	NO WEIR	1-NONE
S01_11	0	NONE	NO WEIR	1-NONE

**CAUTION**  
THE POSITION OF ALL POLE LINES, CONDUITS, WATERMANS, SEWERS AND OTHER UNDERGROUND AND OVERGROUND UTILITIES AND STRUCTURES IS NOT NECESSARILY SHOWN ON THE CONTRACT DRAWINGS, AND WHERE SHOWN, THE ACCURACY OF THE POSITION OF SUCH UTILITIES AND STRUCTURES IS NOT GUARANTEED. BEFORE STARTING WORK, DETERMINE THE EXACT LOCATION OF ALL SUCH UTILITIES AND STRUCTURES AND ASSUME ALL LIABILITY FOR DAMAGE TO THEM.

REV	REVISION DESCRIPTION	DATE	BY	APPD
2	ISSUED FOR CITY REVIEW	22/03/22	AC	BMT
1	ISSUED FOR SITE PLAN CONTROL	15/12/20	SK	BMT

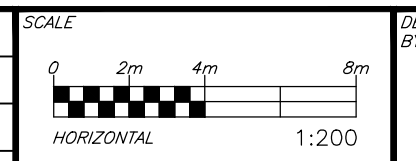

	CLIENT	229 BEECHWOOD HOLDINGS INC. AND 241 BEECHWOOD HOLDINGS INC. C/O BINTEE DEV INC. BINTEE DEV INC. 226 ARGYLE AVE., OTTAWA, ON, K2P 1B9	DESIGNED BY	JLF/ARO	PROJECT	229-247 BEECHWOOD OTTAWA, ON	PROJECT No.	OTT-238207-CO
	CHECKED BY	BMT	DESIGNED BY	BMT	DATE	DEC. 2020	SURVEY	ACV
	PROJECT MANAGER	BMT	DATE	DEC. 2020	DRAWING No.	C100		
	APPROVED BY	BMT						

File Name: \\exp\h\p\2022\238207\238207-05\_0000.dwg  
 User: sk\_bmt  
 Date: 2022/12/21 10:00:00  
 Plot: 2022/12/21 10:00:00  
 Plot Device: HP DesignJet T1100e  
 Plot Style: exp.ctb  
 Plot Range: All  
 Plot Scale: 1:200  
 Plot Orientation: Landscape  
 Plot Color: Black  
 Plot Lineweight: 0.5  
 Plot Linetype: Solid  
 Plot Font: Arial, 10  
 Plot Title: 229-247 BEECHWOOD OTTAWA, ON  
 Plot Author: JLF/ARO  
 Plot Date: 2022/12/21 10:00:00  
 Plot User: sk\_bmt

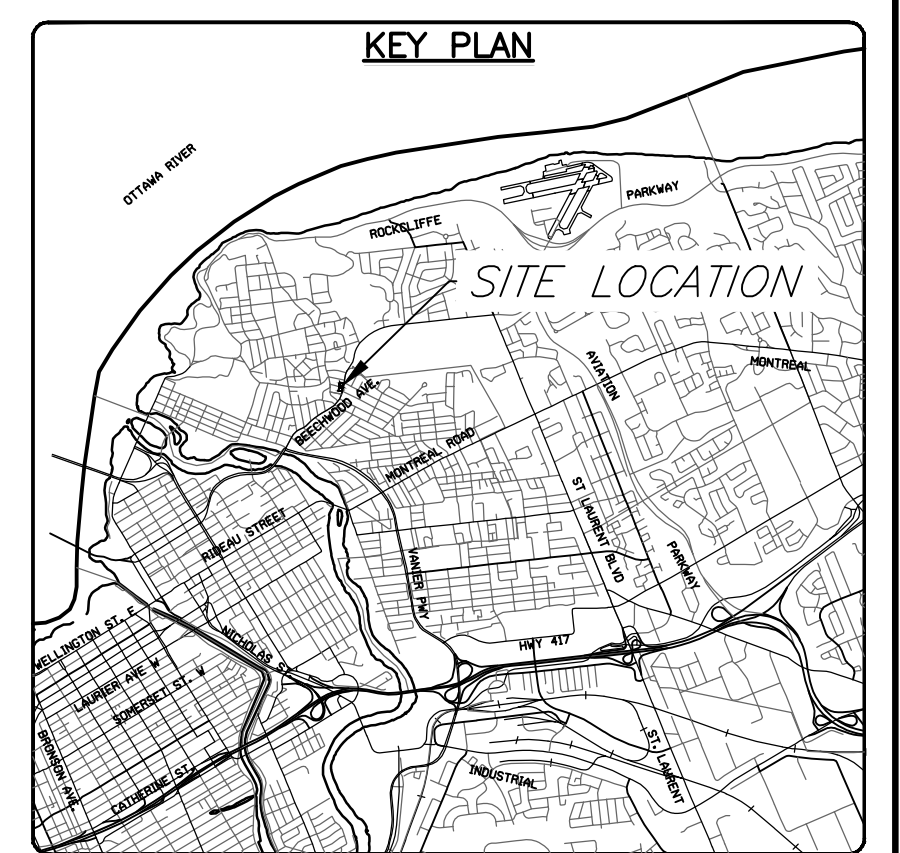
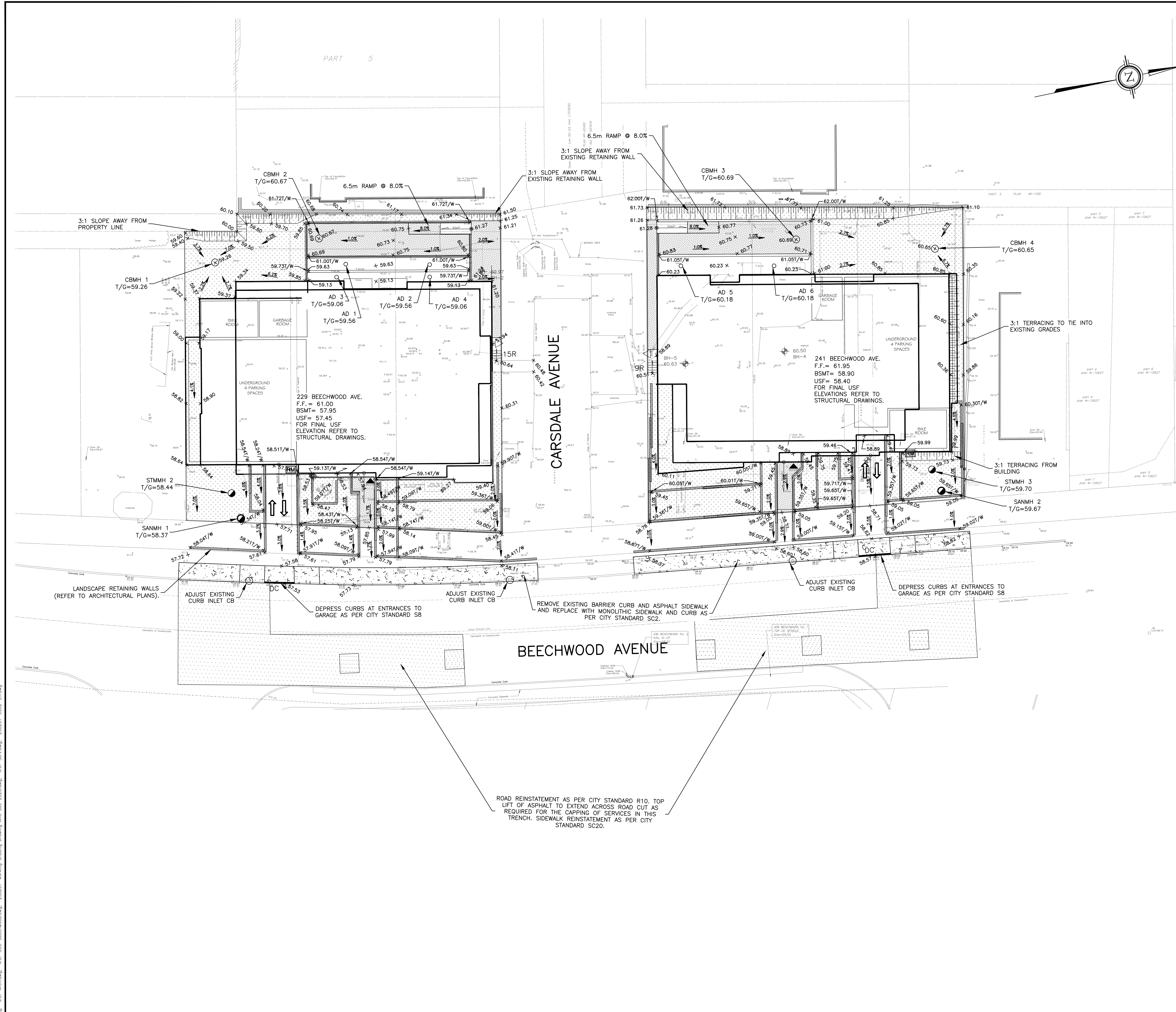

**GENERAL NOTES FOR GRADING**

- IT SHALL BE THE BUILDER'S RESPONSIBILITY TO ENSURE THAT GRADING AROUND HYDRANTS, TRANSFORMERS, AND UTILITY PEDESTALS, ETC., MEET CURRENT CITY OF OTTAWA, HYDRO AND UTILITY COMPANY REQUIREMENTS.
- ALL GROUND SURFACES SHALL BE EVENLY GRADED WITHOUT PONDING AREAS AND WITHOUT LOW POINTS EXCEPT WHERE APPROVED SWALE OR CATCH BASIN OUTLETS ARE PROVIDED.
- CONTRACTOR TO ADJUST EXISTING CATCH BASINS, MANHOLES, FIRE HYDRANTS, VALVE CHAMBERS AND VALVE BOXES TO FINAL GRADE AS REQUIRED.
- CONTRACTOR SHALL TAKE ALL NECESSARY PRECAUTIONS TO PROTECT EXISTING FOUNDATIONS OF ADJACENT BUILDINGS DURING EXCAVATION AND CONSTRUCTION PERIOD.
- GRADING IN GRASSED AREAS WILL BE BETWEEN 2% TO 7%. GRADES IN EXCESS OF 7% WILL REQUIRE A MAXIMUM 3:1 TERRACING.
- NO EXCESS DRAINAGE, DURING OR AFTER CONSTRUCTION, TO BE DIRECTED TOWARDS NEIGHBORING PROPERTIES.
- EXISTING DRAINAGE PATTERNS TO BE MAINTAINED.
- ENSURE POSITIVE DRAINAGE AWAY FROM FOUNDATION.
- NO ALTERATION TO EXISTING GRADES ON THE PROPERTY LINES.
- UNDERSIDE OF FOOTING TO BE MINIMUM 1.5m BELOW FINISHED GRADE OR INSULATION TO BE PROVIDED. TOP OF FOUNDATION TO BE MAINTAINED 0.15m ABOVE FINISHED GRADE.
- FOR ADDITIONAL NOTES REFER TO NOTES AND LEGEND SHEET, DRAWING C001

**CAUTION**  
 THE POSITION OF ALL POLE LINES, CONDUITS, WATERMANS, SEWERS AND OTHER UNDERGROUND AND OVERGROUND UTILITIES AND STRUCTURES IS NOT NECESSARILY SHOWN ON THE CONTRACT DRAWINGS, AND WHERE SHOWN, THE ACCURACY OF THE POSITION OF SUCH UTILITIES AND STRUCTURES IS NOT GUARANTEED. BEFORE STARTING WORK, DETERMINE THE EXACT LOCATION OF ALL SUCH UTILITIES AND STRUCTURES AND ASSUME ALL LIABILITY FOR DAMAGE TO THEM.

REV	REVISION DESCRIPTION	DATE	BY	APPD
2	ISSUED FOR CITY REVIEW	22/03/22	AC	BMT
1	ISSUED FOR SITE PLAN CONTROL	15/12/20	SK	BMT

SCALE  
 0 2m 4m 8m  
 HORIZONTAL 1:200

DESIGNED BY  
 REVIEWED BY

CLIENT  
 229 BEECHWOOD HOLDINGS INC.  
 AND 241 BEECHWOOD HOLDINGS INC.  
 C/O BINTEE DEV INC. BINTEE DEV INC.  
 226 ARGYLE AVE., OTTAWA, ON, K2P 1B9

exp. Services Inc.  
 1-1-613-688-1899 | 1-613-225-7330  
 3025 Queenwood Drive, Unit 100  
 Ottawa, ON K2B 8H6  
 Canada  
 www.exp.com

BASEPLAN SK  
 DESIGN JLF/ARO  
 CHECKED BMT  
 CAD SK  
 PROJECT MANAGER BMT  
 APPROVED BMT

PROJECT  
 229-247 BEECHWOOD  
 OTTAWA, ON

TITLE  
 SITE GRADING PLAN

PROJECT No.  
 OTT-238207-C0

SURVEY  
 AGV

DATE  
 DEC 2020

DRAWING No.  
 C200

REV	REVISION DESCRIPTION	DATE	BY	APPD
2	ISSUED FOR CITY REVIEW	22/03/22	AC	BMT
1	ISSUED FOR SITE PLAN CONTROL	15/12/20	SK	BMT





