

**SEWER SERVICE CONNECTIONS FOR RIGID MAIN SEWER PIPE (MODIFIED OPSD-1006.010)**

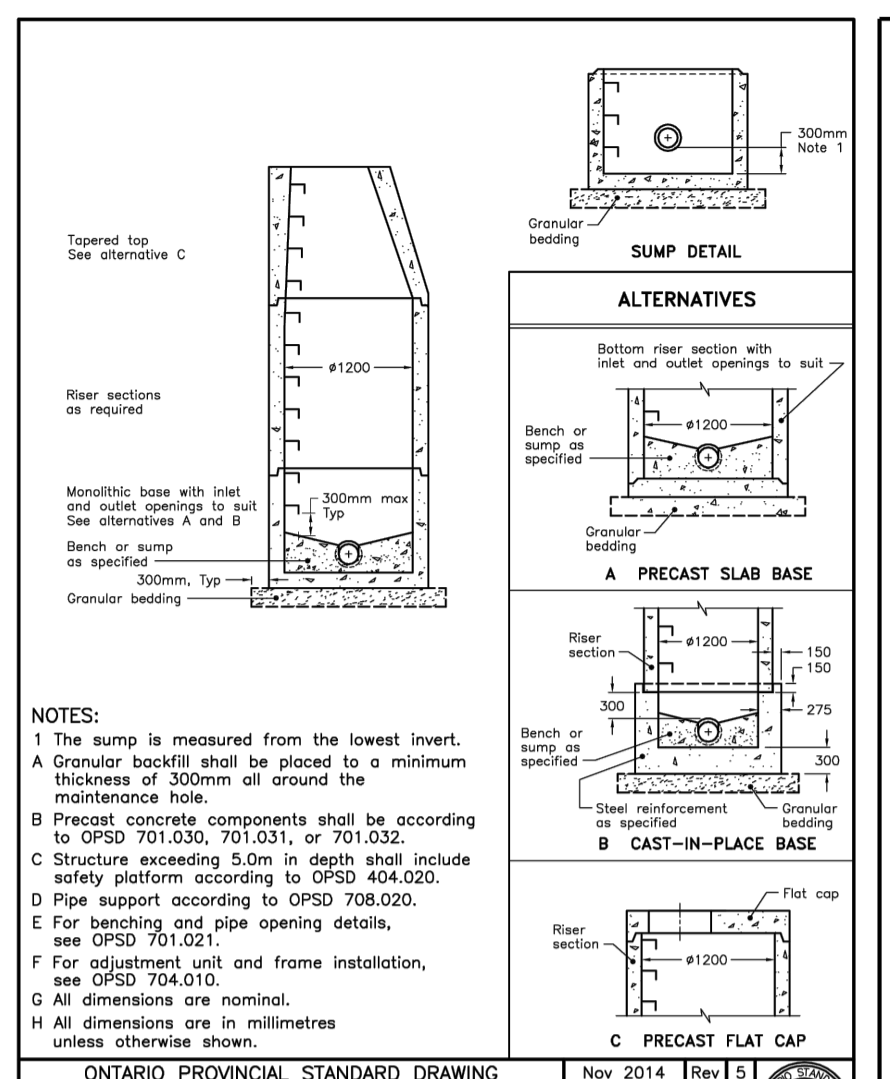

**PRECAST CONCRETE MAINTENANCE HOLE 1200mm DIAMETER OPSD 701.010**

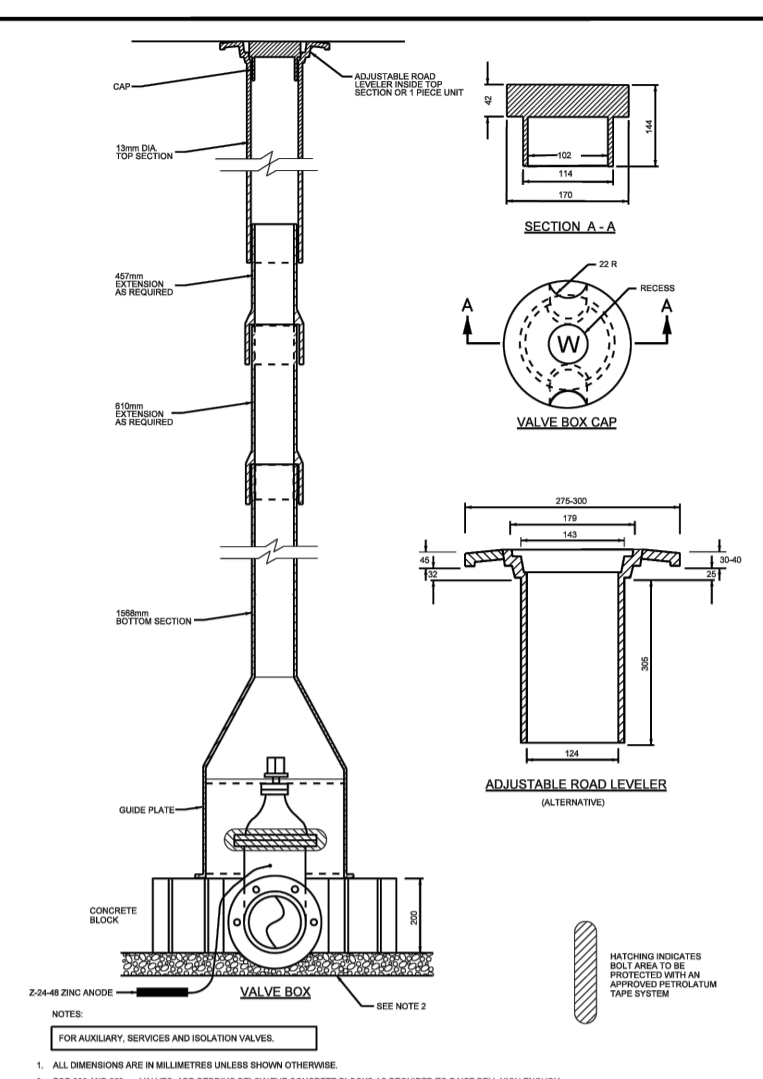

**VALVE BOX ASSEMBLY**

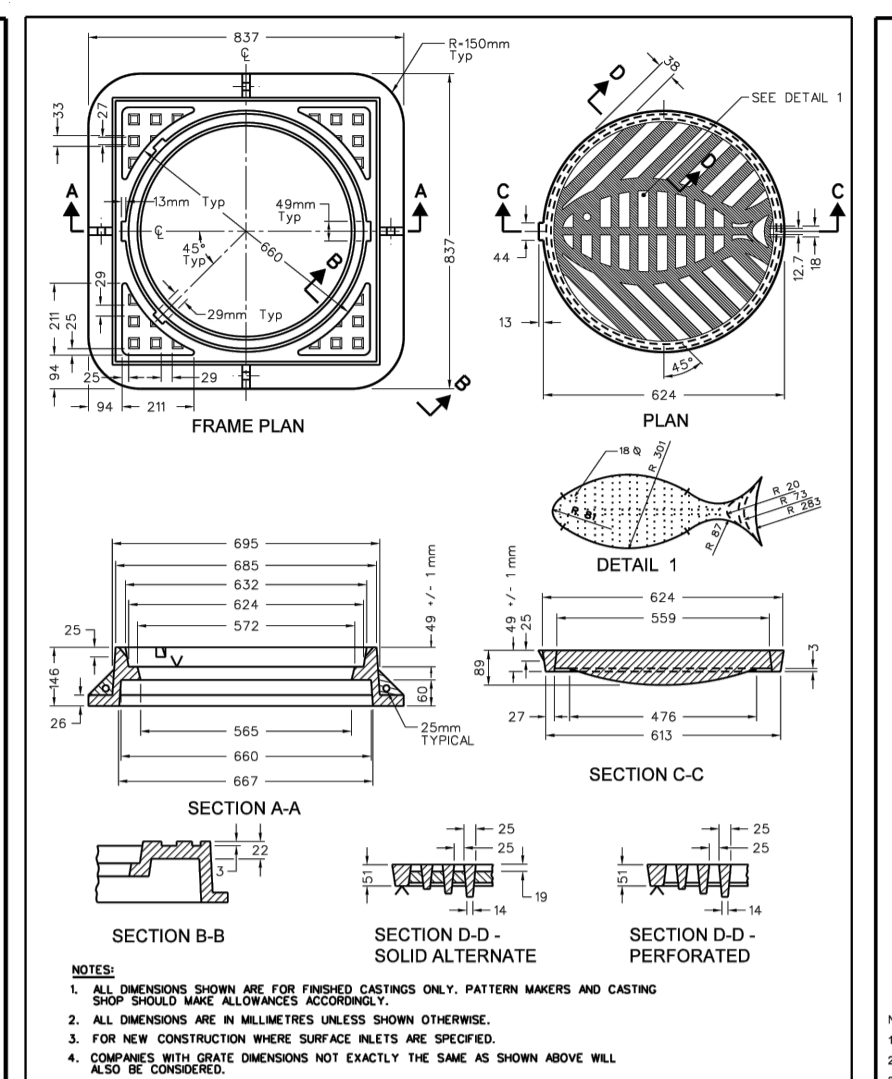

**HEAVY DUTY "FISH" TYPE ROUND CATCH BASIN COVER (MODIFIED OPSD-400.07)**

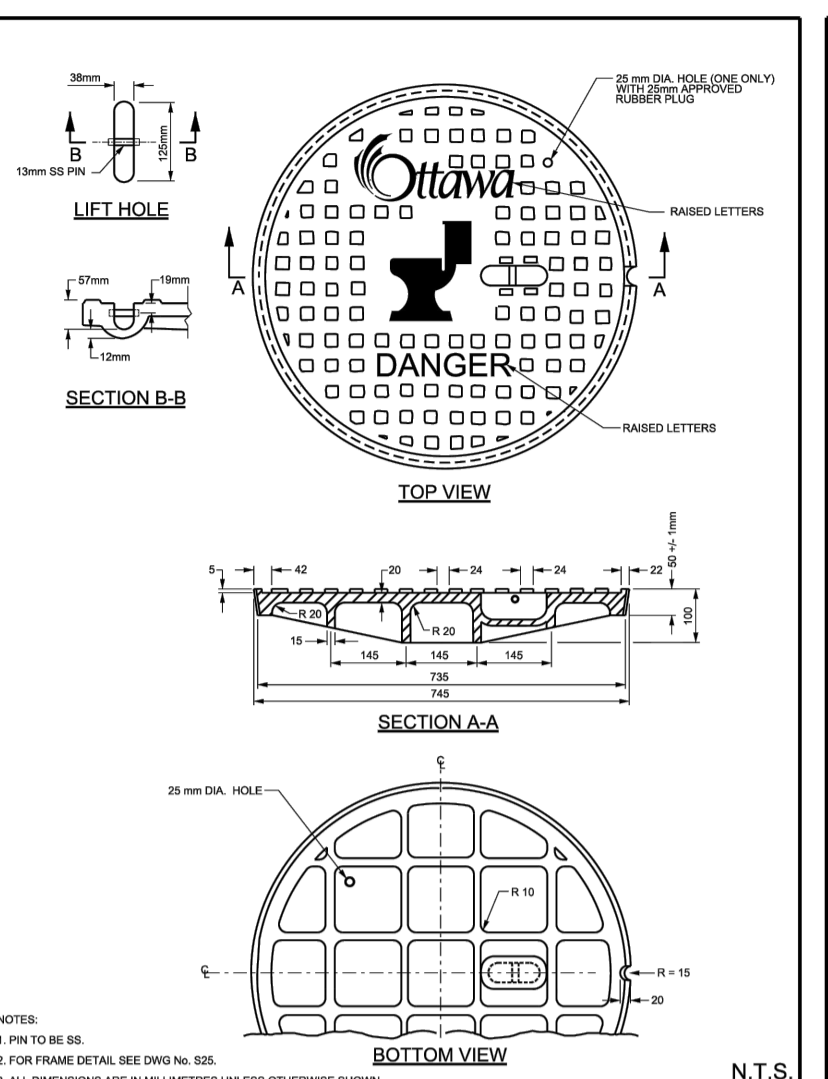

**STANDARD CIRCULAR SANITARY & COMBINED MAINTENANCE HOLE COVER**

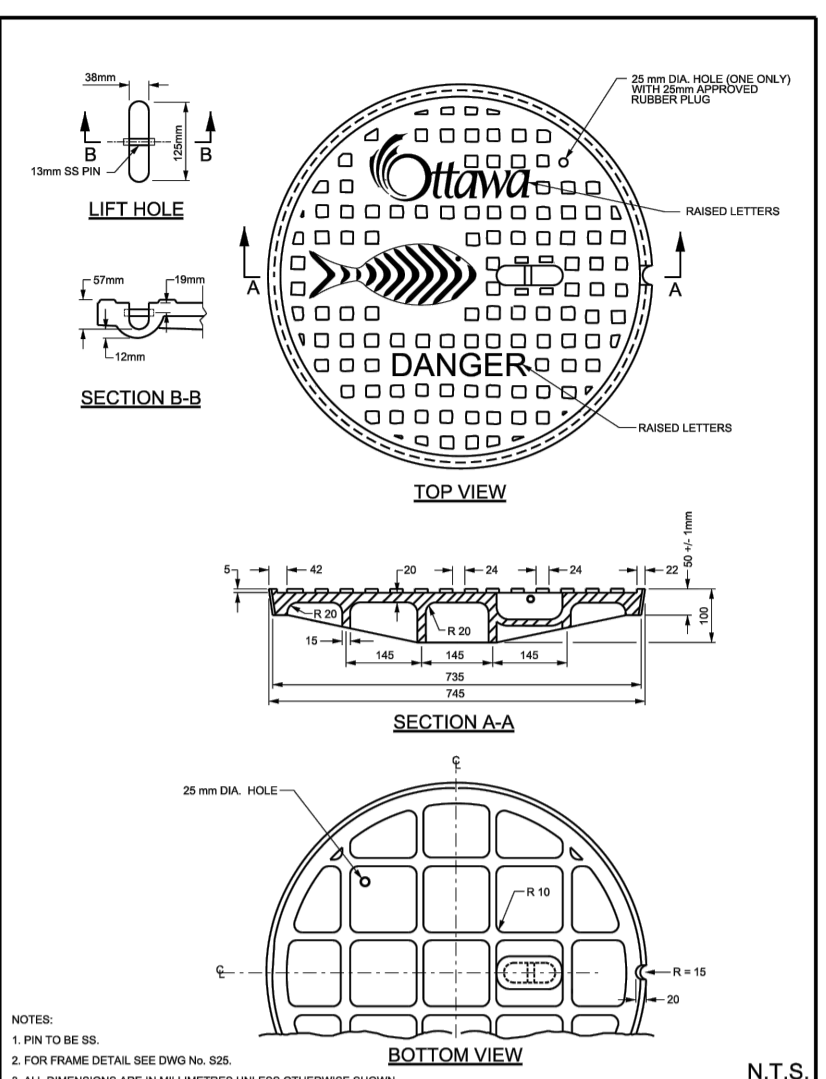

**STANDARD CIRCULAR STORM MAINTENANCE HOLE COVER**

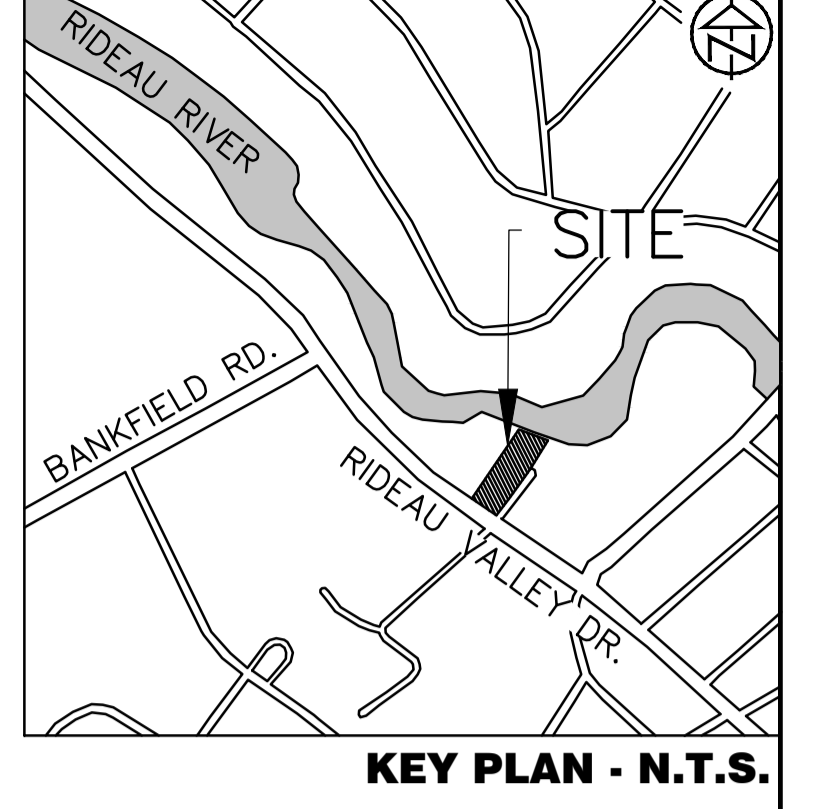

**KEY PLAN - N.T.S.**

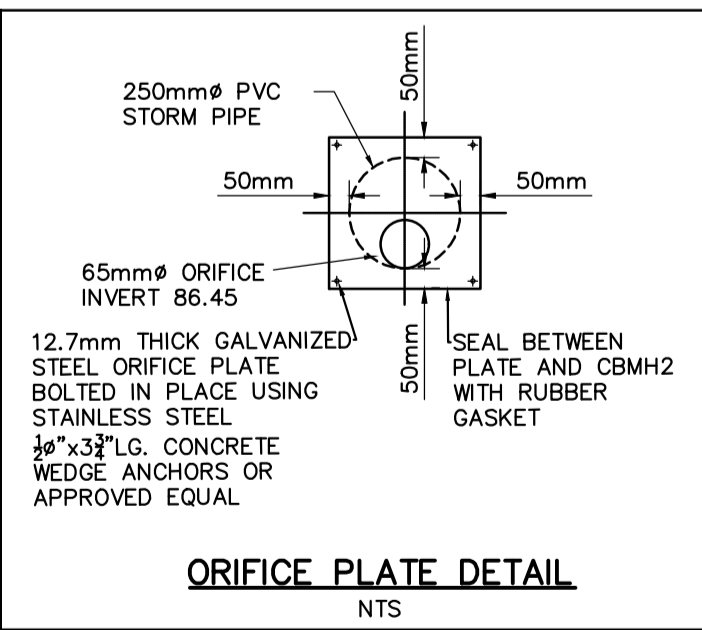
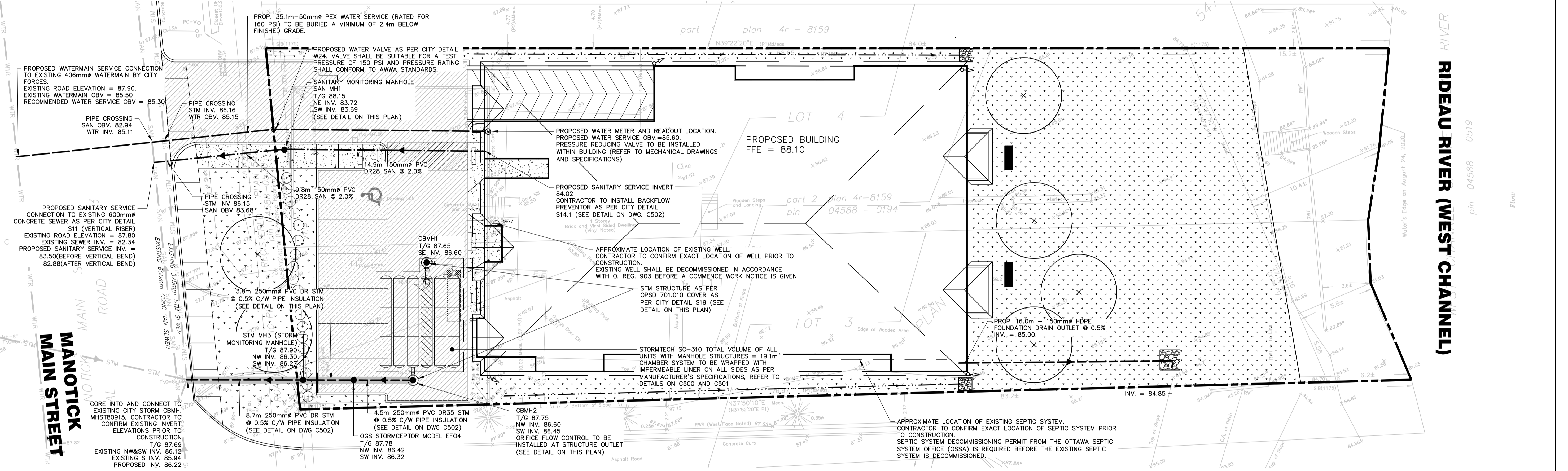

**MANHOLE TABLE**

STORM		
MH Number	Size	Cover
CBMH1	1200mm	S19
CBMH2	1200mm	S19
STM MH3	1200mm	S24.1
SANITARY		
MH Number	Size	Cover
SAN MH1	1200mm	S24

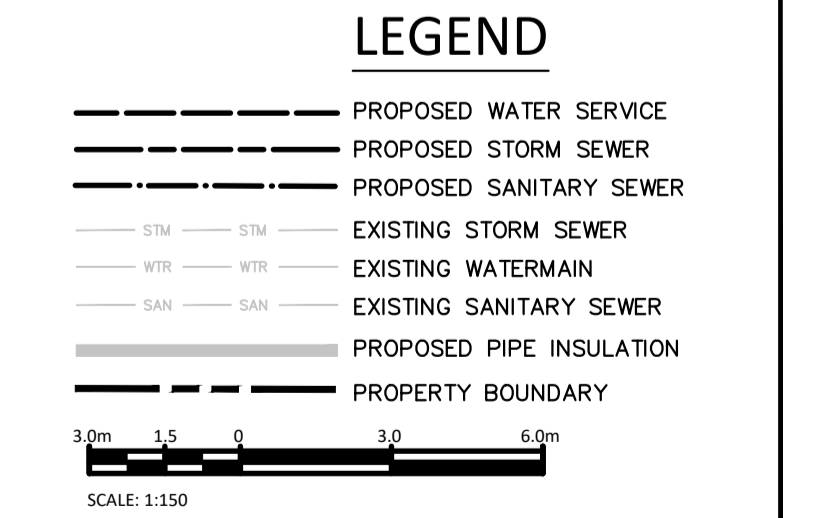

**DISCLAIMER AND COPYRIGHT**  
CONTRACTOR MUST VERIFY ALL DIMENSIONS AND BE RESPONSIBLE FOR SAME. ANY DISCREPANCIES MUST BE REPORTED TO THE ENGINEER BEFORE COMMENCING WORK. DRAWINGS ARE NOT TO BE SCALED.  
TATHAM ENGINEERING LIMITED CLAIMS COPYRIGHT TO THIS DRAWING WHICH MAY NOT BE USED FOR ANY PURPOSE OTHER THAN THAT PROVIDED IN THE CONTRACT BETWEEN THE OWNER/CLIENT AND THE ENGINEER WITHOUT THE EXPRESS CONSENT OF TATHAM ENGINEERING LIMITED.

**SURVEY**  
TOPOGRAPHIC SURVEY WAS COMPLETED BY ANNIS, O'SULLIVAN, VOLLEBEKK LTD. ONTARIO LAND SURVEYORS, DATED JULY 26, 2022. ELEVATIONS SHOWN ARE GEODETIC AND ARE REFER TO THE CGVD28 GEODETIC DATUM.  
**NOTE:** TOP OF CB GRATE LOCATED ON SOUTH SIDE OF SITE ENTRANCE, ELEVATION 87.69.

No.	REVISION DESCRIPTION	DATE	ENGINEER STAMP
1.	ISSUED FOR SPA	JULY, 2023	
2.	RE-ISSUED FOR SPA	MAY, 2024	
3.	RE-ISSUED FOR SPA	OCT, 2024	
4.	RE-ISSUED FOR SPA	NOV, 2024	

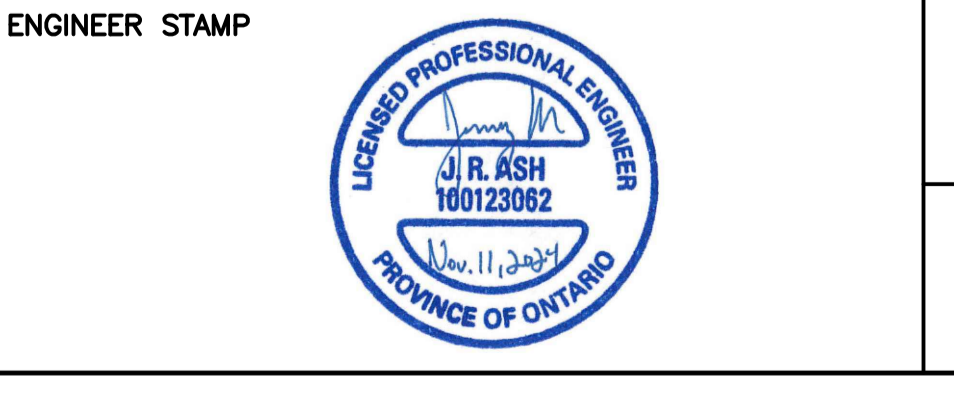

**5497 MANOTICK MAIN ST. CITY OF OTTAWA**

**SITE SERVICING PLAN**

**TATHAM ENGINEERING**

DESIGN: HY FILE: 522679 DWG: **C300**

DRAWN: HY DATE: JULY 2023

CHECK: GC SCALE: 1:150