



Enhancing our communities



# 5497 Manotick Main Street

**SITE SERVICING & STORMWATER MANAGEMENT REPORT**

12213559 Canada Inc.



# Document Contents

<b>1</b>	<b>Introduction .....</b>	<b>1</b>
<b>2</b>	<b>Water Supply and Fire Protection .....</b>	<b>2</b>
2.1	Existing Site Condition .....	2
2.2	Domestic Water Demands .....	2
2.3	Water Service Sizing .....	2
2.4	Fire Protection .....	3
<b>3</b>	<b>Sewage Collection .....</b>	<b>5</b>
3.1	Existing Site Condition .....	5
3.2	Sewage Flows .....	5
3.3	Sanitary Service Sizing .....	5
<b>4</b>	<b>Stormwater Management .....</b>	<b>7</b>
4.1	Stormwater Management Design Criteria.....	7
4.2	Existing Site Drainage Conditions.....	8
4.3	Existing Condition Hydrologic Analysis.....	8
4.4	Proposed SWM PPlan .....	9
4.5	Water Quantity Control.....	10
4.6	Water Quality Control .....	11
<b>5</b>	<b>Erosion and Sediment Control.....</b>	<b>12</b>
<b>6</b>	<b>Summary.....</b>	<b>13</b>

## Tables

Table 1:	Hydrants Required for Fire Flow .....	4
Table 2:	Existing Condition Peak Flow Summary .....	9
Table 3:	Proposed Condition Peak Flow Summary .....	11



## **Appendices**

Appendix A: Water Supply Calculations

Appendix B: Sewage Flow Calculations

Appendix C: Stormwater Management Calculations



# 1 Introduction

Tatham Engineering Limited (Tatham) has been retained by 12213559 Canada Inc. to prepare a Site Servicing & Stormwater Management (SWM) Report in support of Site Plan Approval (SPA) to allow for a proposed 599 m<sup>2</sup> three-storey 21-unit residential building and associated underground and aboveground parking areas located at 5497 Manotick Main Street in the City of Ottawa. Specifically, this report has been prepared to confirm the servicing and SWM designs for the site.

The site is approximately 0.21 ha and currently consists of a one-storey ±250 m<sup>2</sup> building structure to be demolished, a paved parking area, and green space. There is one entrance to the site from Manotick Main Street along the southwest property limit.

The site and the adjacent properties are zoned Village Mixed Use (VM9). The site is bounded by the Rideau River to the northeast, a commercial plaza to the southeast, Manotick Main Street to the southwest, and a residential dwelling to the northwest. A key plan illustrating the site location is provided on the drawings enclosed at the back of this report.

The servicing and SWM designs included herein are based on a topographic survey completed by Annis, O'Sullivan, Vollebakk Ltd. on July 26, 2022.



## 2 Water Supply and Fire Protection

### 2.1 EXISTING SITE CONDITION

In the existing condition, domestic water supply for the site is provided from the City's municipal water system. The existing building is serviced by the existing 406 mm diameter watermain on Manotick Main Street via a 19 mm diameter water service. The existing service will be abandoned and blanked at the main.

Based on geoOttawa online mapping, there are three municipal fire hydrants within 150 m of the site, on Manotick Main Street, Echelon Private, and Highcroft Drive, which can be used for fire protection for the proposed development. The contributions of the existing nearby fire hydrants toward the proposed development's required fire flow are described in further detail in the sections below.

### 2.2 DOMESTIC WATER DEMANDS

The average day water consumption rate and maximum day and peak hour peaking factors used to calculate the water supply demands for the proposed development are based on the 2010 City of Ottawa Design Guidelines for Water Distribution, the 2010 City of Ottawa Technical Bulletin ISD-2010-2 and the 2018 City of Ottawa Technical Bulletin ISTB-2018-01.

Based on an average day water consumption rate of 280 L/c/d and maximum day and peak hour peaking factors of 2.5 and 2.2 respectively, the water demand calculations for the proposed 21-unit residential building confirm an average daily water demand of 0.12 L/s, a maximum daily demand of 0.29 L/s, and a peak hourly demand of 0.64 L/s. The water demands shall be re-confirmed by the mechanical engineer at the building permit phase.

The above water demands do not include allowances for fire protection (i.e. sprinkler systems, etc.), irrigation, etc.

The water demand calculations are included in Appendix A.

### 2.3 WATER SERVICE SIZING

Water service sizing calculations for the proposed condition have been completed using the demands established in Section 2.2 above.

Boundary condition results for the existing conditions and separate results accounting for the reconfiguration of pressure zones in the South Urban Community (SUC), part of the City's Infrastructure Master Plan (IMP) for 2031, were provided by the City of Ottawa and utilized to determine pressures for maximum day and peak hour scenarios. A third scenario, for maximum



day plus fire flow, was deemed unnecessary as the proposed water service will be for domestic water supply only. In general, the pressures slightly exceed the City of Ottawa pressure and demand objectives per Section 4.2.2 of the City of Ottawa Design Guidelines for Water Distribution, which are in conformity with MECP guidelines. The following pressures were calculated for the existing conditions:

- A maximum day demand pressure of 101.05 psi which is above the 50 to 80 psi MECP range; and
- a peak hour demand pressure of 76.45 psi which is within the 40 to 80 psi MECP range.

The following pressures were calculated accounting for the reconfiguration of pressure zones in the SUC by 2031:

- A maximum day demand pressure of 88.96 psi which is above the 50 to 80 psi MECP range; and
- a peak hour demand pressure of 81.85 psi which is above the 40 to 80 psi MECP range.

Based on the above, the proposed building will be serviced with a 50 mm diameter water service, from the existing municipal watermain on Manotick Main Street to the 21-unit residential building. A pressure reducing valve will be required due to the above-noted pressure exceedances. The 100 mm diameter service provides additional capacity for potential unforeseen changes come the building permit phase, and allows for potential future expansion of the proposed development.

The water service sizing and pressure calculations are included in Appendix A.

The existing municipal watermain on Manotick Main Street and the required 50 mm diameter water service to the 21-unit residential building are shown on the Site Servicing Plan (Drawing C300).

## **2.4 FIRE PROTECTION**

The fire flow demand was calculated in accordance with the Office of the Fire Marshal (OFM) Fire Protection Water Supply Guideline for Part 3 in the OBC. This method is based on building occupancy, size, construction and exposures, as well as minimum water supply duration requirements. The fire flow calculations resulted in a fire water demand of 6,300 L/min. Since the proposed building has a footprint less than 600 m<sup>2</sup>, on-site water storage for fire fighting purposes is not required as per Part 9 of the OBC.

The proposed building is located within 90 m of a hydrant, in compliance with OBC requirements. Fire flow protection can be provided by the following three hydrants, which are within 150 m (uninterrupted path) of the building:



- One existing Class AA blue bonnet hydrant located 57 m southeast of the proposed building structure on the north side of Manotick Main Street;
- One existing unclassified hydrant located approximately 109 m south of the proposed building structure on the north side of Echelon Private; and
- One existing unclassified hydrant located approximately 149 m southwest of the proposed building structure on the south side of Highcroft Drive.

Fire hydrant bonnets are color coded to indicate the available flow at a residual pressure of 150 kPa (20 psi), in accordance with the NFPA 291 Fire Flow Testing and Marking of Hydrants Code. The existing hydrant near the site, on Manotick Main Street, consists of a blue bonnet and as such is a Class AA-rated hydrant. The other two existing hydrants, on Echelon Private and Highcroft Drive, are unclassified. Accordingly, fire flow contributions from these hydrants have been considered to be Class C hydrants to be conservative. As is summarized in Table 1, the required 6,300 L/min fire flow to the proposed building is available from the existing hydrants on Manotick Main Street, Echelon Private, and Highcroft Drive.

**Table 1: Hydrants Required for Fire Flow**

HYDRANT CLASS	DISTANCE TO BUILDING (m) <sup>1</sup>	CONTRIBUTION TO REQUIRED FIRE FLOW (L/min)	NUMBER OF USABLE NEARBY HYDRANTS	MAXIMUM FLOW TO BE CONSIDERED (L/min)	CUMULATIVE MAXIMUM FLOW TO BE CONSIDERED (L/min)
AA	≤ 75	5,700	1	5,700	
AA	> 75 & ≤ 150	3,800	0	0	
A	≤ 75	3,800	0	0	
A	> 75 & ≤ 150	2,850	0	0	
B	≤ 75	1,900	0	0	7,300
B	> 75 & ≤ 150	1,500	0	0	
C	≤ 75	800	0	0	
C	> 75 & ≤ 150	800	2	1,600	

Notes: 1. Distance of contributing hydrant from the structure, measured in accordance with NFPA 1.

A hydrant flow test is recommended to confirm the hydrant classes, thereby confirming adequate flow and pressure is available for fire protection.

The fire flow calculations are included in Appendix A.





# 3 Sewage Collection

## 3.1 EXISTING SITE CONDITION

In the existing condition, sewage from the site discharges into the City's municipal sewage collection system. Sewage flows from the existing building discharge to the existing 600 mm diameter sanitary sewer on Manotick Main Street via a 135 mm diameter sanitary service. The existing service will be abandoned, grouted and capped at the property line, in accordance with City of Ottawa Standard Drawing S11.4.

## 3.2 SEWAGE FLOWS

Sewage flow calculations for the proposed development have been completed using the 2012 City of Ottawa Sewer Design Guidelines and the 2018 City of Ottawa Technical Bulletin ISTB-2018-01.

The average daily sewage design flow for the proposed development was determined to be 0.19 L/s, inclusive of extraneous flow.

The sewage flow calculations are included in Appendix B.

## 3.3 SANITARY SERVICE SIZING

The design criteria used to size the sanitary service from the proposed building structure to the existing 600 mm diameter sanitary sewer on Manotick Main Street are as per the 2012 City of Ottawa Sewer Design Guidelines, the 2018 City of Ottawa Technical Bulletin ISTB-2018-01, the 2008 Ministry of the Environment, Conservation and Parks (MECP) Design Guidelines for Sewage Works, and the 2012 OBC. The design criteria are summarized as follows:

- Peak sewage flow derived from the Harmon formula;
- Permissible sewage velocity within MECP range of 0.6 and 3.0 m/s;
- Peak extraneous flow of 0.33 L/s/ha per City of Ottawa Technical Bulletin ISTB-2018-01; and
- Minimum sanitary sewer depth of 2.5 m as per City of Ottawa Sewer Design Guidelines.

Based on the above criteria, the peak sewage flow was calculated to be 0.68 L/s, inclusive of extraneous flow. A 150 mm diameter sanitary service is proposed and will be sufficient to convey the peak sewage flows to the existing municipal sewage collection system on Manotick Main Street.

The sanitary service sizing calculations are included in Appendix B.



The proposed 150 mm diameter sanitary service is shown on the Site Servicing Plan (Drawing C300).



## 4 Stormwater Management

The primary objective of the SWM plan is to demonstrate that post-development conditions will not adversely impact the hydrologic cycle and surface water runoff characteristics of the area. This will be accomplished by evaluating the effects of the proposed development on local drainage conditions. Where necessary, solutions will be provided to mitigate any adverse impacts. The following sections of the report will present the following:

- Existing runoff conditions including constraints and opportunities for improvement;
- Criteria to be applied in the SWM design;
- An overall SWM plan that complies with appropriate technical SWM guidelines; and
- Erosion and sediment control strategies.

The SWM plan was prepared recognizing provincial guidelines on water resources and the environment, including the following publications:

- Design Criteria for Sanitary Sewers, Storm Sewers and Forcemains for Alterations Authorized under Environmental Compliance Approval (The Ministry of the Environment, Conservation and Parks, 2022);
- O. Reg. 174/06: Rideau Valley Conservation Authority: Regulation of Development, Interference with Wetlands and Alterations to Shorelines and Watercourses (2022);
- The City of Ottawa Sewer Design Guidelines (2012) and relevant technical bulletins (ISDTB-2014-01, PIEDTB-2016-01, ISTB 2018-01, ISTB-2018-04 and ISTB-2019-02), and
- Erosion and Sediment Control Guide for Urban Construction (Toronto and Region Conservation Authority, 2019).

### 4.1 STORMWATER MANAGEMENT DESIGN CRITERIA

Criteria met regarding drainage and stormwater management on the site are summarized as follows:

- The site has been developed in accordance with applicable municipal and agency guidelines and standards;
- Attenuation of proposed condition peak flow rates to target peak flow rates will occur during all design storm events;
- MECP “Enhanced” level water quality control is provided, to ensure the development will have no negative impacts on the downstream receivers;



- Safe conveyance of storm flows from all design storm events has been confirmed;
- The proposed storm sewers have been sized for conveyance of the 5-year design storm; and
- Site development includes implementation of erosion and sediment control measures during and following construction to minimize erosion and sediment transport off-site.

#### **4.2 EXISTING SITE DRAINAGE CONDITIONS**

The existing topography, ground cover, and drainage patterns were obtained through a review of available plans, base mapping and site investigation. A detailed topographic survey of the site was completed by Annis, O'Sullivan, Vollebakk Ltd. on July 26, 2022 to confirm the existing features and elevations.

The site is approximately 0.21 ha and currently consists of a one-storey  $\pm 250$  m<sup>2</sup> building structure, a paved parking area, and green space. A well-defined ridge extending across the site from the northwest to the southeast bisects the site into two drainage areas with two distinct outlets.

Runoff from Drainage Area 101 (0.06 ha) drains overland, from the drainage area limits to the centre of the existing parking area, where it is captured by an existing catchbasin and conveyed to the existing municipal storm sewer system on Manotick Main Street via an existing storm pipe.

Runoff from Drainage Area 102 (0.15 ha) drains overland, generally from southwest to northeast, and discharges directly into the Rideau River which is located immediately beyond the northeast property limit.

The Ontario Soil Survey Complex characterizes the native soils onsite as North Gower, having a corresponding hydrologic soil group D.

The Existing Condition Drainage Plan (Drawing C400), illustrating the existing condition drainage characteristics of the site, is attached at the back of this report.

#### **4.3 EXISTING CONDITION HYDROLOGIC ANALYSIS**

A Visual OTTHYMO hydrologic model (V06) scenario was developed to quantify the existing condition peak flows from Drainage Area 101.

Since runoff from Drainage Area 102 discharges directly to the Rideau River and since runoff from Drainage Area 202 (described in detail in Section 4.4) will also discharge directly to the Rideau River, water quantity control for this portion of the site is not required. Accordingly, Drainage Area 102 has been excluded from the hydrologic modelling analysis included herein.

The catchment delineations were determined based on the topographic survey.



A summary of all hydrologic parameters established for the existing condition hydrologic model has been included in Appendix C.

The peak flow for the 2-year storm event was calculated for the 3-hour Chicago, 6-hour Chicago and 24-hour SCS Type II design storms using IDF data derived from Meteorological Services of Canada (MSC) rainfall data taken from the MacDonald-Cartier Airport. Detailed calculations and Visual OTTHYMO modeling output are included in Appendix C with the results summarized below in Table 2.

**Table 2: Existing Condition Peak Flow Summary**

DESIGN STORM	CATCHMENT AREA 101 0.06 ha (m <sup>3</sup> /s)		
	3-hr CHI	6-hr CHI	24-hr SCS Type II
2-Year	0.009	0.009	0.007

#### 4.4 PROPOSED SWM PLAN

The SWM plan recognizes the SWM requirements for the site and has been developed to follow the existing topography of the land as much as possible to maintain the existing condition drainage patterns, while safely conveying stormwater runoff overland.

In the proposed condition, the site will consist of a 594 m<sup>2</sup> three-storey 21-unit residential building, associated underground and aboveground parking areas, and vegetated areas. The existing site entrance near the southeast corner of the site will be decommissioned and a new site entrance near the southwest corner of the site on Manotick Main Street will provide access to the site.

Treated and controlled runoff from the southwest portion of the site (Drainage Area 201) will discharge to the existing 375 mm diameter storm sewer on Manotick Main Street (Outlet 1). Runoff from the northeast portion of the site (Drainage Area 202), consisting of clean runoff from roof and vegetated areas, will discharge to the Rideau River (Outlet 2), unchanged from the existing condition.

The proposed SWM plan is summarized as follows:

- Controlled runoff from Drainage Area 201 (0.06 ha) will discharge to the existing 375 mm diameter storm sewer on Manotick Main Street (Outlet 1). The post development peak flow rate from this area during a 100-year plus 20% stress test event (in accordance with Technical Bulletin PIEDTB-2016-01) will be controlled to the 2-year pre-development peak flow from



Drainage Area 101 (0.06 ha). The above reflects typical stormwater quantity control for sites fronting onto municipal roads serviced with municipal storm sewer.

- Runoff from Drainage Area 201 will be captured by two surface inlets, stored in an underground storage system consisting of underground storage chambers (Stormtech Model SC-740) and controlled by an orifice plate flow restrictor located in CBMH 2.
- Downstream of the orifice flow control, runoff will be treated by a proposed Stormceptor Model EFO4 oil-grit separator (OGS) to provided MECP “Enhanced” level water quality treatment including 80% TSS removal from on-site runoff.
- Runoff from Drainage Area 202, which is clean and unimpaired, will discharge uncontrolled to the Rideau River (Outlet 2), unchanged from the existing condition.
- All internal storm sewers will be sized based on the 5-year design storm.

The Proposed Condition Drainage Plan (Drawing C401), illustrating the proposed condition drainage characteristics of the site, is attached at the back of this report.

#### **4.5 WATER QUANTITY CONTROL**

A 70 mm diameter orifice, installed in CBMH2, is proposed to control peak flows from Drainage Area 201, to ensure the 100-year plus 20% stress test post development peak flow is less than or equal to the existing 2-year peak flow rate from Drainage Area 101.

A VO6 model scenario was developed to quantify the proposed condition peak flow from the site. The peak flow for the 100-year plus 20% stress test storm event was calculated for the 3-hour Chicago, 6-hour Chicago, and 24-hour SCS Type II design storms using the previously described IDF data.

The drainage area delineation for the contributing lands was completed according to the proposed site grading illustrated on Drawing C200, which is included at the back of this report. The proposed surface cover and the existing soil type were used to establish the percent imperviousness, curve numbers, and other hydrologic parameters used in the hydrologic model. Summaries of all hydrologic parameters and stage-storage-discharge tables, established for the post-development hydrologic model, have been included in Appendix C.

Peak runoff rates are shown in the table below and the results of the modelling are included in Appendix C.



**Table 3: Proposed Condition Peak Flow Summary**

DESIGN STORM	DRAINAGE AREA 201 0.06 ha CONTROLLED (m <sup>3</sup> /s)		
	3-hr CHI	6-hr CHI	24-hr SCS TYPE II
100-Year + 20% Stress Test	0.007 (0.009)	0.007 (0.009)	0.007 (0.007)

Note: (0.100) refers to existing condition 2-year peak flow rate.

Table 3 above confirms the proposed SWM plan will attenuate the proposed condition 100-year plus 20% stress test peak flow at or below the existing condition 2-year peak flow. The maximum storage required during the 100-year plus 20% stress test storm was determined to be 24 m<sup>3</sup>, whereas 25 m<sup>3</sup> of storage volume is provided underground, within the underground storage chambers shown on Drawing C300. Additional details related to the Stormtech chamber system are included in Appendix C.

#### 4.6 WATER QUALITY CONTROL

The proposed water quality treatment objective under the proposed condition is to provide MECP enhanced level treatment including 80% TSS removal from on-site runoff.

Water quality control for the development will be provided via a proposed Stormceptor Model EFO4 oil-grit-separator.

##### 4.6.1 Oil-grit-separator

All runoff from Drainage Area 201 will be treated by a Stormceptor Model EFO4 OGS prior to discharging into the 375 mm diameter storm sewer on Manotick Main Street. The OGS has been sized to treat a minimum of 90% of annual runoff and provide 80% TSS removal based on a fine particle size distribution. The specified Stormceptor Model EFO4 will provide 99% TSS removal from the contributing drainage area, thus exceeding the MECP's requirement for enhanced level water quality control. The Stormceptor EFO Sizing Report and its environmental technology verification (ETV) ISO 14034 verification statement is included in Appendix C.



## 5 Erosion and Sediment Control

Erosion and sediment control will be implemented for all construction activities within the development site, including vegetation clearing, topsoil stripping, drive aisle and parking area construction, and stockpiling of materials. The principles considered and to be utilised to minimize erosion and sedimentation at the site and resultant negative environmental impacts consist of the following:

- Minimize disturbance activities where possible;
- Expose the smallest possible land area to erosion for the shortest possible time;
- Institute specified erosion control measures immediately;
- Implement sediment control measures before the outset of construction activities;
- Carry out regular inspections of erosion/sediment control measures and repair or maintain as necessary; and
- Seed or sod exposed soils as soon as possible after construction and keep chemical applications to suppress dust and control pests and vegetation to a minimum.

The proposed grading and building construction for the subject site will be carried out in such a manner that a minimum amount of erosion occurs and such that sedimentation facilities control any erosion that does occur. Specific erosion, sediment, and pollution control measures included within the proposed design, that are to be utilized on-site, consist of the following:

- Erecting a heavy-duty silt fence around the site;
- Installing and maintaining the sediment traps (specifically the Terrafix Siltsacks) within the specified drainage structures;
- Placing and maintaining a stone mud mat at the site's construction entrance;
- Confining refuelling/servicing of equipment to areas well away from the Rideau River and the minor/major drainage system elements; and
- Bi-weekly inspections of control measures to be instituted through a monitoring and mitigation plan and repairs made as necessary.

The proposed erosion and sediment controls are shown on the Siltation and Erosion Control Plan (Drawing C100).





## 6 Summary

The proposed site development has been designed recognizing the pertinent Municipal, Agency, and Provincial guidelines along with site specific constraints and criteria.

The domestic water supply to the proposed building will be provided via a 50 mm diameter water service connected to the existing 406 mm diameter watermain on Manotick Main Street. The available fire flow from the nearest hydrant on Manotick Main Street alone is sufficient to protect the proposed structure from fire. We have assumed that the City's water treatment plant and emergency storage are sufficient to service to proposed development, however, these are to be confirmed by the City.

A 150 mm diameter sanitary service is required from the building structure to the existing 600 mm diameter municipal sanitary sewage system on Manotick Main Street. We have assumed the existing municipal sanitary sewer system and the municipal wastewater treatment plant have adequate capacity to service the proposed development, however, these are required to be confirmed by the City.

The SWM plan for the site includes an underground storage system consisting of underground storage chambers to store runoff. Runoff from the southwest portion of the site (Drainage Area 201 - 0.06 ha) will be controlled underground by an orifice plate flow control prior to discharging to the 375 mm diameter storm sewer on Manotick Main Street. The 100-year plus 20% stress test post development peak flow from this portion of the site will be controlled to the 2-year existing condition peak flow (from Drainage Area 101 - 0.06 ha). Runoff from the northeast portion of the site (Drainage Area 202 - 0.15 ha), which is clean and unimpaired, will discharge uncontrolled to the Rideau River, unchanged from the existing condition. Water quality control for runoff from Drainage Area 201 is proposed to be provided by means of a Stormceptor Model EFO4 OGS, which achieves MECP enhanced level water quality control.

We trust this report is sufficient to confirm the proposed development can be adequately serviced with domestic and fire water supply and sewage collection services and will have no negative impact with regards to SWM.



# Appendix A: Water Supply Calculations





## Fire Flow Calculations

**Tatham File No. :** 522679  
**Project :** 5497 Manotick Main Street  
**Date :** May 8, 2024  
**Designed by :** GC  
**Reviewed by :** JA

Method: Office of the Fire Marshal (OFM) Fire Protection Water Supply Guidelines for Part 3 in the Ontario Building Code (OBC)

### On-Site Fire Protection Water Supply Calculations:

$Q = KVS_{Tot}$  Where: Q = minimum supply of water in litres  
 K = water supply coefficient from Table 1 of the OFM guidelines  
 V = total building volume in cubic metres  
 $S_{Tot}$  = total spacial coefficient values from property line exposures on all sides  
 (Note: if property line runs parallel to road; mesure from building to CL of road)

**Table 3.1.2.1.**  
**Major Occupancy Classification**  
 Forming Part of Sentence 3.1.2.1.(1)

Column 1	Column 2	Column 3
Group	Division	Description of Major Occupancies
A	1	Assembly occupancies intended for the production and viewing of the performing arts
A	2	Assembly occupancies not elsewhere classified in Group A
A	3	Assembly occupancies of the arena type
A	4	Assembly occupancies in which occupants are gathered in the open air
B	1	Detention occupancies
B	2	Care and treatment occupancies
B	3	Care occupancies
C	----	Residential occupancies
D	----	Business and personal services occupancies
E	----	Mercantile occupancies
F	1	High hazard industrial occupancies
F	2	Medium hazard industrial occupancies
F	3	Low hazard industrial occupancies

**TABLE 1**  
**WATER SUPPLY COEFFICIENT -- K**

TYPE OF CONSTRUCTION	Classification by Group or Division in Accordance with Table 3.1.2.1 of the Ontario Building Code				
	A-2 B-1 B-2 B-3 C D	A-4 F-3	A-1 A-3	E F-2	F-1
Building is of noncombustible construction with fire separations and fire-resistance ratings provided in accordance with Subsection 3.2.2. of the OBC, including loadbearing walls, columns and arches.	10	12	14	17	23
Building is of noncombustible construction or of heavy timber construction conforming to Article 3.1.4.6. of the OBC. Floor assemblies are fire separations but with no fire-resistance rating. Roof assemblies, mezzanines, loadbearing walls, columns and arches do not have a fire-resistance rating.	16	19	22	27	37
Building is of combustible construction with fire separations and fire-resistance ratings provided in accordance with Subsection 3.2.2. of the OBC, including loadbearing walls, columns and arches. Noncombustible construction may be used in lieu of fire-resistance rating where permitted in Subsection 3.2.2. of the OBC.	18	22	25	31	41
Building is of combustible construction. Floor assemblies are fire separations but with no fire-resistance rating. Roof assemblies, mezzanines, loadbearing walls, columns and arches do not have a fire-resistance rating.	23	28	32	39	53
<b>Column 1</b>	<b>2</b>	<b>3</b>	<b>4</b>	<b>5</b>	<b>6</b>

K = 16

V = 6,535 m<sup>3</sup> (Based on footprint area of 594.06m<sup>2</sup> and building height of 11.0m)





**Water Pressure Calculations (Existing Condition)**

Tatham File No. : 522679  
 Project : 5497 Manotick Main Street  
 Date : May 9, 2024  
 Designed by : GC  
 Reviewed by : JA

**Piezometric Head Equation (Derived from Bernoulli's Equation)**

$$h = \frac{p}{\gamma} + z$$

Where:

h = HGL (m)

p = Pressure (Pa)

γ = Specific weight (N/m<sup>3</sup>) = 9810

z = Elevation of centreline of pipe (m) = 85.30

Water Pressure at Manotick Main Street Connection			
HGL (m)	Pressure		
		kPa	psi
Max Day	155.7	690.62	100.17
Peak Hour	138.5	521.89	75.69
Max. Day + Fire =	114.2	283.51	41.12

**Hazen Williams Equation**

$$h_f = \frac{10.67 \times Q^{1.85} \times L}{C^{1.85} \times d^{4.87}}$$

Where:

h<sub>f</sub> = Head loss over the length of pipe (m)

Q = Volumetric flow rate (m<sup>3</sup>/s)

L = Length of pipe (m)

C = Pipe roughness coefficient

d = Pipe diameter (m)

**Scenario 1: maximum daily demand**

Q (L/s)	0.29	
C	150	
L (m.)	44.8	
I.D. (mm)	50	
V (m/s)	0.148	
h <sub>r</sub> (m)	0.028	
Head Loss (psi)	0.040	
Pressure (psi)	100.13	
Service Obv. @ Street Connection (m)	85.35	
Service Obv. @ Building Connection (m)	84.70	
Pressure Adjustment (psi)	0.92	(due to service elevation difference from street to building)
Adjusted Min. Pressure (psi)	101.05	(must not be less than 50 psi; must not be more than 80 psi)

**Scenario 2: maximum hourly demand**

Q (L/s)	0.64	
C	150	
L (m.)	44.8	
I.D. (mm)	50	
V (m/s)	0.326	
h <sub>r</sub> (m)	0.121	
Head Loss (psi)	0.171	
Pressure (psi)	75.52	
Service Obv. @ Street Connection (m)	85.35	
Service Obv. @ Building Connection (m)	84.70	
Pressure Adjustment (psi)	0.92	(due to service elevation difference from street to building)
Adjusted Min. Pressure (psi)	76.45	(must not be less than 40 psi; must not be more than 80 psi)

**Note: A pressure reducing valve will be required due to Scenario 1 maximum daily demand results**



**Water Pressure Calculations (SUC Zone Reconfiguration)**

Tatham File No. : 522679  
 Project : 5497 Manotick Main Street  
 Date : May 9, 2024  
 Designed by : GC  
 Reviewed by : JA

**Piezometric Head Equation (Derived from Bernoulli's Equation)**

$$h = \frac{p}{\gamma} + z$$

Where:

h = HGL (m)

p = Pressure (Pa)

γ = Specific weight (N/m<sup>3</sup>) = 9810

z = Elevation of centreline of pipe (m) = 85.30

Water Pressure at Manotick Main Street Connection			
HGL (m)	Pressure		
		kPa	psi
Max Day	147.2	607.24	88.07
Peak Hour	142.3	559.17	81.10
Max. Day + Fire =	123.9	378.67	54.92

**Hazen Williams Equation**

$$h_f = \frac{10.67 \times Q^{1.85} \times L}{C^{1.85} \times d^{4.87}}$$

Where:

h<sub>f</sub> = Head loss over the length of pipe (m)

Q = Volumetric flow rate (m<sup>3</sup>/s)

L = Length of pipe (m)

C = Pipe roughness coefficient

d = Pipe diameter (m)

**Scenario 1: maximum daily demand**

Q (L/s)	0.29	
C	150	
L (m.)	44.8	
I.D. (mm)	50	
V (m/s)	0.148	
h <sub>r</sub> (m)	0.028	
Head Loss (psi)	0.040	
Pressure (psi)	88.03	
Service Obv. @ Street Connection (m)	85.35	
Service Obv. @ Building Connection (m)	84.70	
Pressure Adjustment (psi)	0.92	(due to service elevation difference from street to building)
Adjusted Min. Pressure (psi)	88.96	(must not be less than 50 psi; must not be more than 80 psi)

**Scenario 2: maximum hourly demand**

Q (L/s)	0.64	
C	150	
L (m.)	44.8	
I.D. (mm)	50	
V (m/s)	0.326	
h <sub>r</sub> (m)	0.121	
Head Loss (psi)	0.171	
Pressure (psi)	80.93	
Service Obv. @ Street Connection (m)	85.35	
Service Obv. @ Building Connection (m)	84.70	
Pressure Adjustment (psi)	0.92	(due to service elevation difference from street to building)
Adjusted Min. Pressure (psi)	81.85	(must not be less than 40 psi; must not be more than 80 psi)

**Note: A pressure reducing valve will be required due to Scenario 1 maximum daily demand and Scenario 2 maximum hourly demand results**

## Boundary Conditions 5497 Manotick Main

### Provided Information

Scenario	Demand	
	L/min	L/s
Average Daily Demand	6.60	0.11
Maximum Daily Demand	16.20	0.27
Peak Hour	35.40	0.59
Fire Flow Demand 1	8,500.20	141.67

### Location

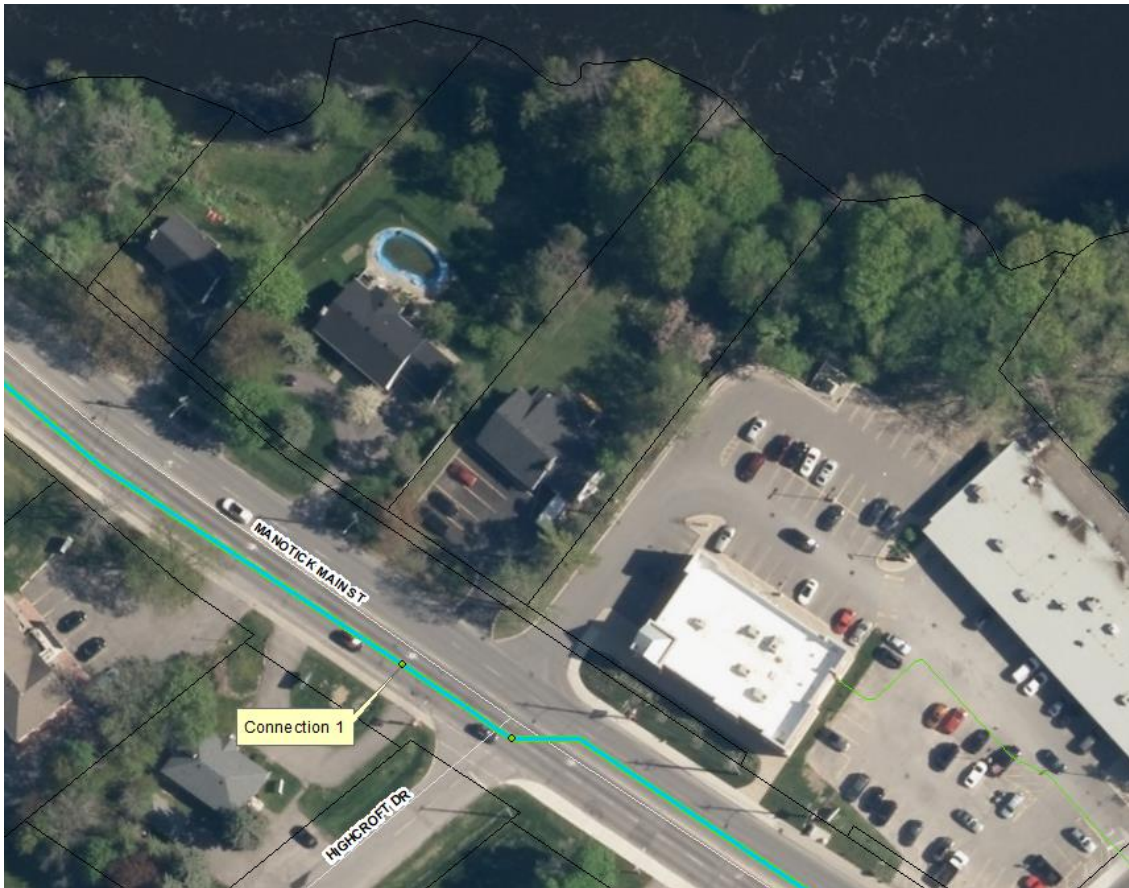

### Results – Existing Conditions

#### Connection 1 – Manotick Main St.

Demand Scenario	Head (m)	Pressure <sup>1</sup> (psi)
Maximum HGL	155.7	96.5
Peak Hour	138.5	72.1
Max Day plus Fire 1	114.2	37.6

<sup>1</sup> Ground Elevation = 87.8 m



## **Results – SUC Zone Reconfiguration**

### **Connection 1 – Manotick Main St.**

<b>Demand Scenario</b>	<b>Head (m)</b>	<b>Pressure<sup>1</sup> (psi)</b>
Maximum HGL	147.2	84.5
Peak Hour	142.3	77.5
Max Day plus Fire 1	123.9	51.4

<sup>1</sup> Ground Elevation = 87.8 m

### **Notes**

1. A second connection to the watermain is required to decrease vulnerability of the water system in case of breaks.
2. As per the Ontario Building Code in areas that may be occupied, the static pressure at any fixture shall not exceed 552 kPa (80 psi.) Pressure control measures to be considered are as follows, in order of preference:
  - a. If possible, systems to be designed to residual pressures of 345 to 552 kPa (50 to 80 psi) in all occupied areas outside of the public right-of-way without special pressure control equipment.
  - b. Pressure reducing valves to be installed immediately downstream of the isolation valve in the home/ building, located downstream of the meter so it is owner maintained.

### **Disclaimer**

*The boundary condition information is based on current operation of the city water distribution system. The computer model simulation is based on the best information available at the time. The operation of the water distribution system can change on a regular basis, resulting in a variation in boundary conditions. The physical properties of watermains deteriorate over time, as such must be assumed in the absence of actual field test data. The variation in physical watermain properties can therefore alter the results of the computer model simulation. Fire Flow analysis is a reflection of available flow in the watermain; there may be additional restrictions that occur between the watermain and the hydrant that the model cannot take into account.*

## **Appendix B: Sewage Flow Calculations**

### Sanitary Flow Calculations

**Tatham File No. :** 522679  
**Project :** 5497 Manotick Main Street  
**Date :** May 9, 2024  
**Designed by :** GC  
**Reviewed by :** JA

#### Sewage Design Flow

##### Sewage Design Flow (Excluding Extraneous Flow)

Unit Type	Population		
	Persons Per Unit	Number of Units	Population
Studio/1 Bedroom Apartment	1.4	12	16.8
2 Bedroom Apartment	2.1	9	18.9
3 Bedroom Apartment	3.1	0	0
		21	35.7

(# of units is in accordance with architectural plans)  
 (population per unit is in accordance with Table 4.2 of 2012 City of Ottawa Sewer Design Guidelines)

Population 36 Persons  
 Sewage Design Flow Rate 280 L/c/d  
 Sewage Design Flow 10,080 L/d 0.12 L/s

(per table above)  
 (per Technical Bulletin ISTB-2018-01)

##### Sewage Design Flow (Including Extraneous Flow)

Extraneous flow 0.33 L/s/ha  
 0.33 L/s \* 0.21 ha  
 5,988 L/d 0.07 L/s  
 Sewage Design Flow 16,068 L/d 0.19 L/s

(per Technical Bulletin ISTB 2018-01, (1/1 dry: 0.05 L/s/ha) + (1/1 wet: 0.28 L/s/ha))  
 (tributary area accounts for entire site (conservative))

#### Sewage Peak Flow

Peaking factor Harmon formula =  $P.F. = 1 + \left( \frac{14}{4 + \left( \frac{P}{1000} \right)^{\frac{1}{2}}} \right) * K$   
 = 3.67

Where: P = 35.7 Persons  
 K = 0.8 Correction Factor

Peak Sewage Flow 59,027 L/s 0.68 L/s



### Sanitary Service Sizing Calculations

**Tatham File No. :** 522679  
**Project :** 5497 Manotick Main Street  
**Date :** May 9, 2024  
**Designed by :** GC  
**Checked by :** JA

**Design Parameters:**

Design flow	16,068 L/day	0.19 L/s	(Inclusive of extraneous flow allowance)
Peaking factor	3.67		(Derived from Harmon formula)
Peak flow	59,027 L/day	0.68 L/s	
Manning's coefficient (n)	0.013		
Minimum velocity	0.6 m/s		
Maximum velocity	3.0 m/s		

From				To				Peak Flow		Pipe					
Tag	Grade level (m)	Invert level (m)	Cover (m)	Tag	Grade level (m)	Invert level (m)	Cover (m)	Peak Flow (L/day)	Peak Flow (L/s)	Length (m)	Dia. (mm)	Slope (%)	Full Capacity (L/s)	Velocity Full (m/s)	Q/Q <sub>full</sub> (%)
BLDG	88.20	84.22	3.83	MONITORING MH	88.08	83.72	4.21	59,027	0.68	25.2	150	2.0%	21.45	1.2	3.2
MONITORING MH	88.08	83.69	4.24	MAIN	87.80	83.50	4.15	59,027	0.68	9.3	150	2.0%	21.77	1.2	3.1

# Appendix C: Stormwater Management Calculations

## Visual OTTHYMO Model Parameter Calculations (NasHYD)

### Project Details

Project Number	522679
----------------	--------

### Data Sources

Detailed Soil Survey Reports for Ontario, MTO Drainage Management Manual (1997)
---------------------------------------------------------------------------------

### Prepared By

Name	HY
------	----

### Pre-Development Condition

Watershed:	N/A
Catchment ID:	101
Catchment Area (ha):	0.06
Impervious %:	67%

### Average Curve Number (CN), Runoff Coefficient (C) and Initial Abstraction (IA)

Soil Symbol	Ng												
Soil Series	North Gower												
Hydrologic Soils Group	D												
Soil Texture	Clay												
Runoff Coefficient Type	3												
Area (ha)	0.06												
Percentage of Catchment	100%												
Land Cover Category	IA	A (ha)	CN	C	A (ha)	CN	C	A (ha)	CN	C	A (ha)	CN	C
Impervious	2	0.04	98	0.95									
Gravel	3		89	0.38									
Woodland	10		79	0.35									
Pasture/Lawns	5	0.02	84	0.40									
Meadows	8		81	0.38									
Cultivated	7		86	0.55									
Waterbody	12		50	0.05									
Average CN	93.33												
Average C	0.77												
Average IA	3.00												

### Time to Peak Calculations

Max. Catchment Elev. (m):	88.00
Min. Catchment Elev. (m):	87.62
Catchment Length (m):	22
Catchment Slope (%):	1.73%
Method:	Bransby-Williams Formula
Time of Concentration (mins):	1.49

### Summary

Catchment CN:	93.3
Catchment C:	0.77
Catchment IA (mm):	3.00
Time of Concentration (hrs):	0.02
Catchment Time to Peak (hrs):	0.02
Catchment Time Step (mins):	0.20

## Visual OTTHYMO Model Parameter Calculations (NasHYD)

### Project Details

Project Number	522679
----------------	--------

### Data Sources

Detailed Soil Survey Reports for Ontario, MTO Drainage Management Manual (1997)
---------------------------------------------------------------------------------

### Prepared By

Name	HY
------	----

### Pre-Development Condition

Watershed:	N/A
Catchment ID:	102
Catchment Area (ha):	0.15
Impervious %:	7%

### Average Curve Number (CN), Runoff Coefficient (C) and Initial Abstraction (IA)

Soil Symbol	Ng												
Soil Series	North Gower												
Hydrologic Soils Group	D												
Soil Texture	Clay												
Runoff Coefficient Type	3												
Area (ha)	0.15												
Percentage of Catchment	100%												
Land Cover Category	IA	A (ha)	CN	C	A (ha)	CN	C	A (ha)	CN	C	A (ha)	CN	C
Impervious	2	0.01	98	0.95									
Gravel	3		89	0.54									
Woodland	10		79	0.52									
Pasture/Lawns	5	0.14	84	0.55									
Meadows	8		81	0.54									
Cultivated	7		86	0.70									
Waterbody	12		50	0.05									
Average CN	84.93												
Average C	0.58												
Average IA	4.80												

### Time to Peak Calculations

Max. Catchment Elev. (m):	88.00
Min. Catchment Elev. (m):	81.03
Catchment Length (m):	57
Catchment Slope (%):	12.23%
Method:	Bransby-Williams Formula
Time of Concentration (mins):	2.38

### Summary

Catchment CN:	84.9
Catchment C:	0.58
Catchment IA (mm):	4.80
Time of Concentration (hrs):	0.04
Catchment Time to Peak (hrs):	0.03
Catchment Time Step (mins):	0.32

## Visual OTTHYMO Model Parameter Calculations (NasHYD)

### Project Details

Project Number	522679
----------------	--------

### Data Sources

Detailed Soil Survey Reports for Ontario, MTO Drainage Management Manual (1997)
---------------------------------------------------------------------------------

### Prepared By

Name	HY
------	----

### Pre-Development Condition

Watershed:	N/A
Catchment ID:	201
Catchment Area (ha):	0.06
Impervious %:	90%

### Average Curve Number (CN), Runoff Coefficient (C) and Initial Abstraction (IA)

Soil Symbol	Ng												
Soil Series	North Gower												
Hydrologic Soils Group	D												
Soil Texture	Clay												
Runoff Coefficient Type	3												
Area (ha)	0.06												
Percentage of Catchment	100%												
Land Cover Category	IA	A (ha)	CN	C	A (ha)	CN	C	A (ha)	CN	C	A (ha)	CN	C
Impervious	2	0.05	98	0.95									
Gravel	3		89	0.38									
Woodland	10		79	0.35									
Pasture/Lawns	5	0.01	84	0.40									
Meadows	8		81	0.38									
Cultivated	7		86	0.55									
Waterbody	12		50	0.05									
Average CN	96.60												
Average C	0.90												
Average IA	2.30												

### Time to Peak Calculations

Max. Catchment Elev. (m):	87.95
Min. Catchment Elev. (m):	87.60
Catchment Length (m):	12
Catchment Slope (%):	2.92%
Method:	Bransby-Williams Formula
Time of Concentration (mins):	0.73

### Summary

Catchment CN:	96.6
Catchment C:	0.90
Catchment IA (mm):	2.30
Time of Concentration (hrs):	0.01
Catchment Time to Peak (hrs):	0.01
Catchment Time Step (mins):	0.10



## Visual OTTHYMO Model Parameter Calculations (NasHYD)

### Project Details

Project Number	522679
----------------	--------

### Data Sources

Detailed Soil Survey Reports for Ontario, MTO Drainage Management Manual (1997)
---------------------------------------------------------------------------------

### Prepared By

Name	HY
------	----

### Pre-Development Condition

Watershed:	N/A
Catchment ID:	202
Catchment Area (ha):	0.15
Impervious %:	47%

### Average Curve Number (CN), Runoff Coefficient (C) and Initial Abstraction (IA)

Soil Symbol	Ng												
Soil Series	North Gower												
Hydrologic Soils Group	D												
Soil Texture	Clay												
Runoff Coefficient Type	3												
Area (ha)	0.15												
Percentage of Catchment	100%												
Land Cover Category	IA	A (ha)	CN	C	A (ha)	CN	C	A (ha)	CN	C	A (ha)	CN	C
Impervious	2	0.07	98	0.95									
Gravel	3		89	0.54									
Woodland	10		79	0.52									
Pasture/Lawns	5	0.08	84	0.55									
Meadows	8		81	0.54									
Cultivated	7		86	0.70									
Waterbody	12		50	0.05									
Average CN	90.53												
Average C	0.74												
Average IA	3.60												

### Time to Peak Calculations

Max. Catchment Elev. (m):	88.00
Min. Catchment Elev. (m):	81.03
Catchment Length (m):	57
Catchment Slope (%):	12.23%
Method:	Bransby-Williams Formula
Time of Concentration (mins):	2.38

### Summary

Catchment CN:	90.5
Catchment C:	0.74
Catchment IA (mm):	3.60
Time of Concentration (hrs):	0.04
Catchment Time to Peak (hrs):	0.03
Catchment Time Step (mins):	0.32



Project :	5497 Manotick
File No.	522679
Date:	Jan-23
Designed By:	HY
Checked By:	GC
Subject:	SWM Chamber Discharge Table

**OUTLET CONTROL**

**Orifice Control**

	Orifice	Pipe
Orifice Size (mm):	65	250
Cross-Sectional Area (sq.m):	0.003318	0.049087
Orifice Coefficient:	0.61	0.80
Invert Elevation (m):	86.45	77.40
Outlet Pipe Size (mm):	250	250

**STAGE DISCHARGE TABLE & CONTROL STRUCTURE CONFIGURATION**

Water Level	65 mm dia. Orifice		250 PVC	Total Discharge	Active Storage
	Head	Discharge	Capacity		
(m)	(m)	(cms)	(cms)	(cms)	(cm)
86.60	0.12	0.003	0.123	0.003	0.0
86.65	0.17	0.004	0.123	0.004	3.2
86.70	0.22	0.004	0.123	0.004	6.2
86.75	0.27	0.005	0.123	0.005	9.1
86.80	0.32	0.005	0.123	0.005	11.9
86.85	0.37	0.005	0.123	0.005	14.6
86.90	0.42	0.006	0.123	0.006	16.9
86.95	0.47	0.006	0.123	0.006	18.9
87.00	0.52	0.006	0.123	0.006	20.6
87.05	0.57	0.007	0.123	0.007	22.1
87.10	0.62	0.007	0.123	0.007	23.6
87.15	0.67	0.007	0.123	0.007	25.1

**Proposed Condition (Controlled area)**

Design Storm	SWM Facility Operating Characteristics			
	Required Storage (m <sup>3</sup> )	Provided Storage (m <sup>3</sup> )	Total Outflow (m <sup>3</sup> )	Water Level (m)
2yr 24hr SCS	6	6	0.004	86.70
2yr 3hr Chicago	6	6	0.004	86.70
2yr 6hr Chicago	6	6	0.004	86.70
100yr 24hr SCS	18	19	0.006	86.93
100yr 3hr Chicago	19	21	0.006	86.95
100yr 6hr Chicago	19	21	0.006	86.95
100yr 24hr SCS (20% Stress test)	23	24	0.007	87.08
100yr 3hr Chicago (20% Stress test)	23	24	0.007	87.08
100yr 6hr Chicago (20% Stress test)	24	25	0.007	87.11



Project :	5497 Manotick Main st.
File No.	523650
Date:	Jan-23
Designed By:	HY
Checked By:	GC
Subject:	Dry LID SWM Facility

Underground Storage Chambers (Stormtech Model SC-310)

Elevation	Depth	Quantity Volume	Total chambers	Total Volume
(m)	(m)	(m <sup>3</sup> )	(ea)	(m <sup>3</sup> )
86.60	0.00	0.00	24	0.0
86.65	0.00	0.13	24	3.0
86.70	0.05	0.25	24	6.0
86.75	0.10	0.37	24	8.8
86.80	0.15	0.48	24	11.5
86.85	0.20	0.58	24	14.0
86.90	0.25	0.68	24	16.3
86.95	0.30	0.76	24	18.1
87.00	0.35	0.82	24	19.7
87.05	0.40	0.88	24	21.1
87.10	0.45	0.93	24	22.4
87.15	0.50	0.99	24	23.9

Storm Structure Storage

Elevation	Depth	Quantity Volume	Total Structure	Total Volume
(m)	(m)	(m <sup>3</sup> )	(ea)	(m <sup>3</sup> )
86.60	0.00	0.00	2.00	0.00
86.65	0.05	0.06	2.00	0.11
86.70	0.10	0.11	2.00	0.23
86.75	0.15	0.17	2.00	0.34
86.80	0.20	0.23	2.00	0.45
86.85	0.25	0.28	2.00	0.57
86.90	0.30	0.34	2.00	0.68
86.95	0.35	0.40	2.00	0.79
87.00	0.40	0.45	2.00	0.90
87.05	0.45	0.51	2.00	1.02
87.10	0.50	0.57	2.00	1.13
87.15	0.55	0.62	2.00	1.24

PRE SCS

=====

```

V   V   I   SSSSS  U   U   A   L           (v 6.2.2015)
V   V   I   SS     U   U   A A  L
V   V   I   SS     U   U   AAAAA L
V   V   I   SS     U   U   A   A  L
  VV    I   SSSSS  UUUUU  A   A  LLLLL

```

```

  000  TTTTT  TTTTT  H   H  Y   Y  M   M  000  TM
  0   0   T    T    H   H  Y Y  MM MM  0   0
  0   0   T    T    H   H  Y   M   M  0   0
  000   T    T    H   H  Y   M   M  000

```

Developed and Distributed by Smart City Water Inc  
 Copyright 2007 - 2022 Smart City Water Inc  
 All rights reserved.

\*\*\*\*\* S U M M A R Y O U T P U T \*\*\*\*\*

Input filename: C:\Program Files (x86)\Visual OTTHYMO 6.2\V02\voin.dat

Output filename:

C:\Users\hyu\AppData\Local\Civica\XH5\e2c2d2be-418b-4c4d-a4c4-d228733f752c\b7c673a3-d93a-420f-bf9f-618013aa73aa\scenario

Summary filename:

C:\Users\hyu\AppData\Local\Civica\XH5\e2c2d2be-418b-4c4d-a4c4-d228733f752c\b7c673a3-d93a-420f-bf9f-618013aa73aa\scenario

DATE: 05/09/2024

TIME: 03:04:21

USER:

COMMENTS: \_\_\_\_\_

```

*****
** SIMULATION : Run 01           **
*****

```

W/E COMMAND	HYD ID	DT min	AREA ha	Qpeak ' cms	Tpeak hrs	R.V. mm	R.C.	Qbase cms
-------------	--------	-----------	------------	----------------	--------------	------------	------	--------------

START @ 0.00 hrs

-----

READ STORM 5.0

[ Ptot= 49.09 mm ]

fname :

C:\Users\hyu\AppData\Local\Temp\c9d38ee1-92aa-482c-b8da-8f3e6737526a\a83aa445-7986-4108-a295-abaadc5

remark: Ottawa Macdonald Cartier SCS 24 2yr

\*

\*\* CALIB NASHYD 0102 1 5.0 0.15 0.01 12.00 21.85 0.45 0.000

[CN=84.9 ]

[ N = 3.0:Tp 0.17 ]

\*

READ STORM 5.0

[ Ptot= 49.09 mm ]

fname :

C:\Users\hyu\AppData\Local\Temp\c9d38ee1-92aa-482c-b8da-8f3e6737526a\a83aa445-7986-4108-a295-abaadc5

remark: Ottawa Macdonald Cartier SCS 24 2yr

\*

\* CALIB STANDHYD 0101 1 5.0 0.06 0.01 12.00 37.01 0.75 0.000

[I%=67.0:S%= 2.00]

\*

=====  
=====

V V I SSSSS U U A L (v 6.2.2015)  
V V I SS U U A A L  
V V I SS U U AAAAA L  
V V I SS U U A A L  
VV I SSSSS UUUUU A A LLLLL

000 TTTTT TTTTT H H Y Y M M 000 TM  
0 0 T T H H Y Y MM MM 0 0  
0 0 T T H H Y M M 0 0  
000 T T H H Y M M 000

Developed and Distributed by Smart City Water Inc  
Copyright 2007 - 2022 Smart City Water Inc  
All rights reserved.

\*\*\*\*\* S U M M A R Y O U T P U T \*\*\*\*\*

Input filename: C:\Program Files (x86)\Visual OTTHYMO 6.2\V02\voin.dat

Output filename:

C:\Users\hyu\AppData\Local\Civica\H5\2c2d2be-418b-4c4d-a4c4-d228733f752c\4761ae12-6660-4e1c-9676-d871b8093e32\scenario

Summary filename:  
C:\Users\hyu\AppData\Local\Civica\XH5\e2c2d2be-418b-4c4d-a4c4-d228733f752c\4761ae12-6660-4e1c-9676-d871b8093e32\scenario

DATE: 05/09/2024

TIME: 03:04:22

USER:

COMMENTS: \_\_\_\_\_

\*\*\*\*\*  
\*\* SIMULATION : Run 02 \*\*  
\*\*\*\*\*

W/E COMMAND	HYD ID	DT min	AREA ha	Qpeak ' cms	Tpeak hrs	R.V. mm	R.C.	Qbase cms
-------------	--------	-----------	------------	----------------	--------------	------------	------	--------------

START @ 0.00 hrs

-----  
READ STORM 5.0

[ Ptot= 65.91 mm ]

fname :

C:\Users\hyu\AppData\Local\Temp\c9d38ee1-92aa-482c-b8da-8f3e6737526a\5aca6ac2-ef25-4c6b-b023-6eea581

remark: Ottawa Macdonald Cartier SCS 24 5yr

\*  
\*\* CALIB NASHYD 0102 1 5.0 0.15 0.01 12.00 35.01 0.53 0.000  
[CN=84.9 ]  
[ N = 3.0:Tp 0.17 ]  
\*

READ STORM 5.0

[ Ptot= 65.91 mm ]

fname :

C:\Users\hyu\AppData\Local\Temp\c9d38ee1-92aa-482c-b8da-8f3e6737526a\5aca6ac2-ef25-4c6b-b023-6eea581

remark: Ottawa Macdonald Cartier SCS 24 5yr

\*  
\* CALIB STANDHYD 0101 1 5.0 0.06 0.01 12.00 54.64 0.83 0.000  
[I%=67.0:S%= 2.00]  
\*

=====  
=====

```

V   V   I   SS   U   U   A   A   L
V   V   I   SS   U   U   AAAAA L
V   V   I   SS   U   U   A   A   L
  WV   I   SSSSS UUUUU A   A   LLLLL

```

```

000   TTTT   TTTT   H   H   Y   Y   M   M   000   TM
0   0   T   T   H   H   Y   Y   MM   MM   0   0
0   0   T   T   H   H   Y   M   M   0   0
000   T   T   H   H   Y   M   M   000

```

Developed and Distributed by Smart City Water Inc  
 Copyright 2007 - 2022 Smart City Water Inc  
 All rights reserved.

\*\*\*\*\* S U M M A R Y O U T P U T \*\*\*\*\*

Input filename: C:\Program Files (x86)\Visual OTTHYMO 6.2\V02\voin.dat

Output filename:

C:\Users\hyu\AppData\Local\Civica\XH5\e2c2d2be-418b-4c4d-a4c4-d228733f752c\c92f24e4-8db6-46b0-88af-6f3a6a3a6952\scenario

Summary filename:

C:\Users\hyu\AppData\Local\Civica\XH5\e2c2d2be-418b-4c4d-a4c4-d228733f752c\c92f24e4-8db6-46b0-88af-6f3a6a3a6952\scenario

DATE: 05/09/2024

TIME: 03:04:22

USER:

COMMENTS: \_\_\_\_\_

```

*****
** SIMULATION : Run 03          **
*****

```

W/E COMMAND	HYD ID	DT	AREA	Qpeak	Tpeak	R.V.	R.C.	Qbase
		min	ha	cms	hrs	mm		cms

START @ 0.00 hrs

-----  
 READ STORM 5.0  
 [ Ptot= 77.00 mm ]  
 fname :

C:\Users\hyu\AppData\Local\Temp\c9d38ee1-92aa-482c-b8da-8f3e6737526a\937e7433-4342-40da-96a5-67c3cdf

remark: Ottawa Macdonald Cartier SCS 24 10yr

```

*
** CALIB NASHYD      0102  1  5.0   0.15   0.02 12.00  44.25 0.57   0.000
   [CN=84.9          ]
   [ N = 3.0:Tp 0.17]

```

```

*
READ STORM          5.0
[ Ptot= 77.00 mm ]
fname :

```

```

C:\Users\hyu\AppData\Local\Temp\c9d38ee1-92aa-482c-b8da-8f3e6737526a\937e7433-4342-4
0da-96a5-67c3cdf
remark: Ottawa Macdonald Cartier SCS 24 10yr

```

```

*
* CALIB STANDHYD    0101  1  5.0   0.06   0.01 12.00  65.08 0.85   0.000
   [I%=67.0:S%= 2.00]

```

```

=====
=====

```

```

V  V  I  SSSSS  U  U  A  L          (v 6.2.2015)
V  V  I  SS    U  U  A  A  L
V  V  I  SS    U  U  AAAAA L
V  V  I  SS    U  U  A  A  L
VV   I  SSSSS  UUUUU  A  A  LLLLL

```

```

000  TTTTT  TTTTT  H  H  Y  Y  M  M  000  TM
0  0  T  T  H  H  Y  Y  MM MM 0  0
0  0  T  T  H  H  Y  M  M  0  0
000  T  T  H  H  Y  M  M  000

```

Developed and Distributed by Smart City Water Inc  
 Copyright 2007 - 2022 Smart City Water Inc  
 All rights reserved.

\*\*\*\*\* S U M M A R Y O U T P U T \*\*\*\*\*

Input filename: C:\Program Files (x86)\Visual OTTHYMO 6.2\V02\voin.dat

Output filename:

C:\Users\hyu\AppData\Local\Civica\XH5\e2c2d2be-418b-4c4d-a4c4-d228733f752c\e47b3e90-6d5b-4b5b-a0dd-45c31ff72924\scenario

Summary filename:

C:\Users\hyu\AppData\Local\Civica\XH5\e2c2d2be-418b-4c4d-a4c4-d228733f752c\e47b3e90-6d5b-4b5b-a0dd-45c31ff72924\scenario

DATE: 05/09/2024

TIME: 03:04:22



USER:

COMMENTS: \_\_\_\_\_

\*\*\*\*\*  
\*\* SIMULATION : Run 04 \*\*  
\*\*\*\*\*

W/E COMMAND	HYD ID	DT min	AREA ha	Qpeak cms	Tpeak hrs	R.V. mm	R.C.	Qbase cms
-------------	--------	-----------	------------	--------------	--------------	------------	------	--------------

START @ 0.00 hrs

-----  
READ STORM 5.0

[ Ptot= 91.08 mm ]

fname :

C:\Users\hyu\AppData\Local\Temp\c9d38ee1-92aa-482c-b8da-8f3e6737526a\8677e260-0877-4303-925b-23f8544

remark: Ottawa Macdonald Cartier SCS 24 25yr

\*

\*\* CALIB NASHYD 0102 1 5.0 0.15 0.02 12.00 56.42 0.62 0.000

[CN=84.9 ]

[ N = 3.0:Tp 0.17]

\*

READ STORM 5.0

[ Ptot= 91.08 mm ]

fname :

C:\Users\hyu\AppData\Local\Temp\c9d38ee1-92aa-482c-b8da-8f3e6737526a\8677e260-0877-4303-925b-23f8544

remark: Ottawa Macdonald Cartier SCS 24 25yr

\*

\* CALIB STANDHYD 0101 1 5.0 0.06 0.01 12.00 78.49 0.86 0.000

[I%=67.0:S%= 2.00]

\*

=====  
=====

V V I SSSSS U U A L (v 6.2.2015)

V V I SS U U A A L

V V I SS U U AAAAA L

V V I SS U U A A L

VV I SSSSS UUUUU A A LLLLL

000 TTTTT TTTTT H H Y Y M M 000 TM

```

    0 0 T T H H Y Y MM MM 0 0
    0 0 T T H H Y M M 0 0
    000 T T H H Y M M 000

```

Developed and Distributed by Smart City Water Inc  
 Copyright 2007 - 2022 Smart City Water Inc  
 All rights reserved.

\*\*\*\*\* S U M M A R Y O U T P U T \*\*\*\*\*

Input filename: C:\Program Files (x86)\Visual OTTHYMO 6.2\V02\voin.dat

Output filename:

C:\Users\hyu\AppData\Local\Civica\XH5\e2c2d2be-418b-4c4d-a4c4-d228733f752c\f68a9a6e-b8dc-491f-bbd5-38b0c62db25c\scenario

Summary filename:

C:\Users\hyu\AppData\Local\Civica\XH5\e2c2d2be-418b-4c4d-a4c4-d228733f752c\f68a9a6e-b8dc-491f-bbd5-38b0c62db25c\scenario

DATE: 05/09/2024

TIME: 03:04:22

USER:

COMMENTS: \_\_\_\_\_

```

*****
** SIMULATION : Run 05 **
*****

```

W/E COMMAND	HYD ID	DT min	AREA ha	Qpeak cms	Tpeak hrs	R.V. mm	R.C.	Qbase cms
-------------	--------	-----------	------------	--------------	--------------	------------	------	--------------

START @ 0.00 hrs

```

-----
READ STORM                5.0
[ Ptot=101.52 mm ]
fname :

```

C:\Users\hyu\AppData\Local\Temp\c9d38ee1-92aa-482c-b8da-8f3e6737526a\55c88cf1-c07d-4de2-b4c7-fa9ea96

remark: Ottawa Macdonald Cartier SCS 24 50yr

```

*
** CALIB NASHYD          0102  1  5.0   0.15   0.03 12.00  65.69 0.65   0.000
   [CN=84.9              ]
   [ N = 3.0:Tp 0.17]
*

```

READ STORM 5.0

[ Ptot=101.52 mm ]

fname :

C:\Users\hyu\AppData\Local\Temp\c9d38ee1-92aa-482c-b8da-8f3e6737526a\55c88cf1-c07d-4de2-b4c7-fa9ea96

remark: Ottawa Macdonald Cartier SCS 24 50yr

\*

\* CALIB STANDHYD 0101 1 5.0 0.06 0.02 12.00 88.51 0.87 0.000  
[I%=67.0:S%= 2.00]

\*

=====  
=====

V V I SSSSS U U A L (v 6.2.2015)  
V V I SS U U A A L  
V V I SS U U AAAAA L  
V V I SS U U A A L  
VV I SSSSS UUUUU A A LLLLL

000 TTTTT TTTTT H H Y Y M M 000 TM  
0 0 T T H H Y Y MM MM 0 0  
0 0 T T H H Y M M 0 0  
000 T T H H Y M M 000

Developed and Distributed by Smart City Water Inc  
Copyright 2007 - 2022 Smart City Water Inc  
All rights reserved.

\*\*\*\*\* S U M M A R Y O U T P U T \*\*\*\*\*

Input filename: C:\Program Files (x86)\Visual OTTHYMO 6.2\V02\voin.dat

Output filename:

C:\Users\hyu\AppData\Local\Civica\XH5\e2c2d2be-418b-4c4d-a4c4-d228733f752c\f81c5622-08d5-48bf-bca3-1eb71c45cbd7\scenario

Summary filename:

C:\Users\hyu\AppData\Local\Civica\XH5\e2c2d2be-418b-4c4d-a4c4-d228733f752c\f81c5622-08d5-48bf-bca3-1eb71c45cbd7\scenario

DATE: 05/09/2024

TIME: 03:04:22

USER:

COMMENTS: \_\_\_\_\_

\*\*\*\*\*  
 \*\* SIMULATION : Run 06 \*\*  
 \*\*\*\*\*

W/E COMMAND	HYD ID	DT min	AREA ha	Qpeak cms	Tpeak hrs	R.V. mm	R.C.	Qbase cms
-------------	--------	-----------	------------	--------------	--------------	------------	------	--------------

START @ 0.00 hrs

-----  
 READ STORM 5.0

[ Ptot=111.87 mm ]

fname :

C:\Users\hyu\AppData\Local\Temp\c9d38ee1-92aa-482c-b8da-8f3e6737526a\20e7578-d439-4ffb-8edc-8fe2588

remark: Ottawa Macdonald Cartier SCS 24 100yr

\*

\*\* CALIB NASHYD 0102 1 5.0 0.15 0.03 12.00 75.03 0.67 0.000

[ CN=84.9 ]

[ N = 3.0:Tp 0.17 ]

\*

READ STORM 5.0

[ Ptot=111.87 mm ]

fname :

C:\Users\hyu\AppData\Local\Temp\c9d38ee1-92aa-482c-b8da-8f3e6737526a\20e7578-d439-4ffb-8edc-8fe2588

remark: Ottawa Macdonald Cartier SCS 24 100yr

\*

\* CALIB STANDHYD 0101 1 5.0 0.06 0.02 12.00 98.52 0.88 0.000

[ I%=67.0:S%= 2.00 ]

\*

FINISH

=====  
 =====

PRE CHI

=====

```

V   V   I   SSSSS  U   U   A   L           (v 6.2.2015)
V   V   I   SS     U   U   A A  L
V   V   I   SS     U   U   AAAAA L
V   V   I   SS     U   U   A   A  L
  VV    I   SSSSS  UUUUU  A   A  LLLLL

```

```

  000  TTTTT  TTTTT  H   H  Y   Y  M   M   000  TM
  0   0   T    T    H   H  Y Y  MM MM  0   0
  0   0   T    T    H   H   Y   M   M  0   0
  000   T    T    H   H   Y   M   M  000

```

Developed and Distributed by Smart City Water Inc  
 Copyright 2007 - 2022 Smart City Water Inc  
 All rights reserved.

\*\*\*\*\* S U M M A R Y O U T P U T \*\*\*\*\*

Input filename: C:\Program Files (x86)\Visual OTTHYMO 6.2\V02\voin.dat

Output filename:

C:\Users\hyu\AppData\Local\Civica\VH5\e2c2d2be-418b-4c4d-a4c4-d228733f752c\09443e52-7ec0-4d0a-8568-7bb5d6f11259\scenario

Summary filename:

C:\Users\hyu\AppData\Local\Civica\VH5\e2c2d2be-418b-4c4d-a4c4-d228733f752c\09443e52-7ec0-4d0a-8568-7bb5d6f11259\scenario

DATE: 05/09/2024

TIME: 03:04:36

USER:

COMMENTS: \_\_\_\_\_

```

*****
** SIMULATION : Ottawa 2yr 3hr Chicago      **
*****

```

W/E COMMAND	HYD ID	DT min	AREA ha	Qpeak ' cms	Tpeak hrs	R.V. mm	R.C.	Qbase cms
-------------	--------	-----------	------------	----------------	--------------	------------	------	--------------

START @ 0.00 hrs

-----

```

CHIC STORM                10.0
[ Ptot= 31.86 mm ]
*
* CALIB STANDHYD          0101  1  5.0   0.06   0.01  1.00  23.66 0.74  0.000
[ I%=67.0:S%= 2.00]
*
CHIC STORM                10.0
[ Ptot= 31.86 mm ]
*
* CALIB NASHYD            0003  1  5.0   0.15   0.01  1.17  10.10 0.32  0.000
[ CN=84.9          ]
[ N = 3.0:Tp 0.17]
*

```

```

=====
=====

```

```

V  V  I  SSSSS  U  U  A  L                (v 6.2.2015)
V  V  I  SS    U  U  A  A  L
V  V  I  SS    U  U  AAAAA  L
V  V  I  SS    U  U  A  A  L
WV   I  SSSSS  UUUUU  A  A  LLLLL

```

```

000  TTTTT  TTTTT  H  H  Y  Y  M  M  000  TM
0  0  T  T  H  H  Y  Y  MM  MM  0  0
0  0  T  T  H  H  Y  M  M  0  0
000  T  T  H  H  Y  M  M  000

```

Developed and Distributed by Smart City Water Inc  
 Copyright 2007 - 2022 Smart City Water Inc  
 All rights reserved.

\*\*\*\*\* S U M M A R Y O U T P U T \*\*\*\*\*

Input filename: C:\Program Files (x86)\Visual OTTHYMO 6.2\V02\voin.dat

Output filename:  
 C:\Users\hyu\AppData\Local\Civica\XH5\e2c2d2be-418b-4c4d-a4c4-d228733f752c\a1cfc619-2c32-4aa1-942f-6127ffa28ffd\scenario  
 Summary filename:  
 C:\Users\hyu\AppData\Local\Civica\XH5\e2c2d2be-418b-4c4d-a4c4-d228733f752c\a1cfc619-2c32-4aa1-942f-6127ffa28ffd\scenario

DATE: 05/09/2024

TIME: 03:04:37

USER:

COMMENTS: \_\_\_\_\_

\*\*\*\*\*  
\*\* SIMULATION : Ottawa 2yr 6hr Chicago \*\*  
\*\*\*\*\*

W/E COMMAND	HYD ID	DT min	AREA ha	Qpeak cms	Tpeak hrs	R.V. mm	R.C.	Qbase cms
-------------	--------	-----------	------------	--------------	--------------	------------	------	--------------

START @ 0.00 hrs

-----  
CHIC STORM 10.0  
[ Ptot= 36.86 mm ]

\*  
\* CALIB STANDHYD 0101 1 5.0 0.06 0.01 2.00 28.10 0.76 0.000  
[ I%=67.0:S%= 2.00 ]

\*  
CHIC STORM 10.0  
[ Ptot= 36.86 mm ]

\*  
\* CALIB NASHYD 0003 1 5.0 0.15 0.01 2.17 13.26 0.36 0.000  
[ CN=84.9 ]  
[ N = 3.0:Tp 0.17 ]

\*  
FINISH

=====  
=====

POST SCS

=====

```

V   V   I   SSSSS  U   U   A   L           (v 6.2.2015)
V   V   I   SS     U   U   A A  L
V   V   I   SS     U   U   AAAAA L
V   V   I   SS     U   U   A   A  L
  VV    I   SSSSS  UUUUU  A   A  LLLLL

```

```

  000  TTTTT  TTTTT  H   H  Y   Y  M   M  000  TM
  0   0   T    T    H   H  Y Y  MM MM  0   0
  0   0   T    T    H   H   Y   M   M  0   0
  000   T    T    H   H   Y   M   M  000

```

Developed and Distributed by Smart City Water Inc  
 Copyright 2007 - 2022 Smart City Water Inc  
 All rights reserved.

\*\*\*\*\* S U M M A R Y O U T P U T \*\*\*\*\*

Input filename: C:\Program Files (x86)\Visual OTTHYMO 6.2\V02\voin.dat

Output filename:

C:\Users\hyu\AppData\Local\Civica\XH5\e2c2d2be-418b-4c4d-a4c4-d228733f752c\dead66f3-c7bd-44fa-ab3e-b90bcaf4653d\scenario

Summary filename:

C:\Users\hyu\AppData\Local\Civica\XH5\e2c2d2be-418b-4c4d-a4c4-d228733f752c\dead66f3-c7bd-44fa-ab3e-b90bcaf4653d\scenario

DATE: 05/09/2024

TIME: 03:09:19

USER:

COMMENTS: \_\_\_\_\_

```

*****
** SIMULATION : Run 01           **
*****

```

W/E COMMAND	HYD ID	DT min	AREA ha	Qpeak ' cms	Tpeak hrs	R.V. mm	R.C.	Qbase cms
-------------	--------	-----------	------------	----------------	--------------	------------	------	--------------

START @ 0.00 hrs

-----



READ STORM 5.0

[ Ptot= 49.09 mm ]

fname :

C:\Users\hyu\AppData\Local\Temp\41bb3133-f008-436a-8b76-c26e92215004\a83aa445-7986-4108-a295-abaadc5

remark: Ottawa Macdonald Cartier SCS 24 2yr

\*

\* CALIB STANDHYD 0072 1 5.0 0.06 0.01 12.00 43.09 0.88 0.000  
[I%=90.0:S%= 2.00]

\*

\*\* Reservoir

OUTFLOW: 0074 1 5.0 0.06 0.00 11.92 42.97 n/a 0.000

\*

READ STORM 5.0

[ Ptot= 49.09 mm ]

fname :

C:\Users\hyu\AppData\Local\Temp\41bb3133-f008-436a-8b76-c26e92215004\a83aa445-7986-4108-a295-abaadc5

remark: Ottawa Macdonald Cartier SCS 24 2yr

\*

\* CALIB STANDHYD 0073 1 5.0 0.15 0.01 12.00 33.68 0.69 0.000  
[I%=47.0:S%= 2.00]

\*

=====  
=====

V V I SSSSS U U A L (v 6.2.2015)  
V V I SS U U A A L  
V V I SS U U AAAAA L  
V V I SS U U A A L  
VV I SSSSS UUUUU A A LLLLL

000 TTTTT TTTTT H H Y Y M M 000 TM  
0 0 T T H H Y Y MM MM 0 0  
0 0 T T H H Y M M 0 0  
000 T T H H Y M M 000

Developed and Distributed by Smart City Water Inc  
Copyright 2007 - 2022 Smart City Water Inc  
All rights reserved.

\*\*\*\*\* S U M M A R Y O U T P U T \*\*\*\*\*

Input filename: C:\Program Files (x86)\Visual OTTHYMO 6.2\V02\voin.dat

Output filename:

C:\Users\hyu\AppData\Local\Civica\XH5\e2c2d2be-418b-4c4d-a4c4-d228733f752c\3e1f6bf3-ccfb-4f8c-872e-40caa5f9ed93\scenario

Summary filename:

C:\Users\hyu\AppData\Local\Civica\XH5\e2c2d2be-418b-4c4d-a4c4-d228733f752c\3e1f6bf3-ccfb-4f8c-872e-40caa5f9ed93\scenario

DATE: 05/09/2024

TIME: 03:09:19

USER:

COMMENTS: \_\_\_\_\_

\*\*\*\*\*  
\*\* SIMULATION : Run 02 \*\*  
\*\*\*\*\*

W/E COMMAND	HYD ID	DT	AREA	Qpeak	Tpeak	R.V.	R.C.	Qbase
		min	ha	cms	hrs	mm		cms

START @ 0.00 hrs

-----  
READ STORM 5.0  
[ Ptot= 65.91 mm ]  
fname :

C:\Users\hyu\AppData\Local\Temp\41bb3133-f008-436a-8b76-c26e92215004\5aca6ac2-ef25-4c6b-b023-6eea581

remark: Ottawa Macdonald Cartier SCS 24 5yr

* CALIB STANDHYD	0072	1	5.0	0.06	0.01	12.00	61.81	0.94	0.000
[ I%=90.0:S%= 2.00 ]									

** Reservoir									
OUTFLOW:	0074	1	5.0	0.06	0.00	12.08	61.70	n/a	0.000

\* READ STORM 5.0  
[ Ptot= 65.91 mm ]  
fname :

C:\Users\hyu\AppData\Local\Temp\41bb3133-f008-436a-8b76-c26e92215004\5aca6ac2-ef25-4c6b-b023-6eea581

remark: Ottawa Macdonald Cartier SCS 24 5yr

* CALIB STANDHYD	0073	1	5.0	0.15	0.02	12.00	48.46	0.74	0.000
[ I%=47.0:S%= 2.00 ]									

\*\*\*\*\*

=====

```

V   V   I   SSSSS U   U   A   L           (v 6.2.2015)
V   V   I   SS    U   U   A A  L
V   V   I   SS    U   U   AAAAA L
V   V   I   SS    U   U   A   A  L
  W    I   SSSSS UUUUU A   A  LLLLL

```

```

000  TTTTT  TTTTT  H   H  Y   Y  M   M  000  TM
0   0   T    T    H   H  Y Y  MM MM  0   0
0   0   T    T    H   H  Y   M   M  0   0
000  T    T    H   H  Y   M   M  000

```

Developed and Distributed by Smart City Water Inc  
 Copyright 2007 - 2022 Smart City Water Inc  
 All rights reserved.

\*\*\*\*\* S U M M A R Y O U T P U T \*\*\*\*\*

Input filename: C:\Program Files (x86)\Visual OTTHYMO 6.2\V02\voin.dat

Output filename:

C:\Users\hyu\AppData\Local\Civica\XH5\e2c2d2be-418b-4c4d-a4c4-d228733f752c\20983300-3dd2-4350-9aff-ecc9603591ad\scenario

Summary filename:

C:\Users\hyu\AppData\Local\Civica\XH5\e2c2d2be-418b-4c4d-a4c4-d228733f752c\20983300-3dd2-4350-9aff-ecc9603591ad\scenario

DATE: 05/09/2024

TIME: 03:09:19

USER:

COMMENTS: \_\_\_\_\_

```

*****
** SIMULATION : Run 03           **
*****

```

W/E COMMAND	HYD ID	DT min	AREA ha	Qpeak ' cms	Tpeak hrs	R.V. mm	R.C.	Qbase cms
-------------	--------	-----------	------------	----------------	--------------	------------	------	--------------

START @ 0.00 hrs

-----

READ STORM 5.0

[ Ptot= 77.00 mm ]

fname :  
 C:\Users\hyu\AppData\Local\Temp\41bb3133-f008-436a-8b76-c26e92215004\937e7433-4342-40da-96a5-67c3cdf  
 remark: Ottawa Macdonald Cartier SCS 24 10yr

\*  
 \* CALIB STANDHYD           0072 1 5.0    0.06    0.01 12.00  72.70 0.94    0.000  
 [I%=90.0:S%= 2.00]

\*  
 \*\* Reservoir  
 OUTFLOW:                   0074 1 5.0    0.06    0.00 12.00  72.57 n/a    0.000

\*  
 READ STORM                           5.0  
 [ Ptot= 77.00 mm ]  
 fname :

C:\Users\hyu\AppData\Local\Temp\41bb3133-f008-436a-8b76-c26e92215004\937e7433-4342-40da-96a5-67c3cdf  
 remark: Ottawa Macdonald Cartier SCS 24 10yr

\*  
 \* CALIB STANDHYD           0073 1 5.0    0.15    0.02 12.00  58.50 0.76    0.000  
 [I%=47.0:S%= 2.00]

=====  
 =====

V V I SSSSS U U A L (v 6.2.2015)  
 V V I SS U U A A L  
 V V I SS U U AAAAA L  
 V V I SS U U A A L  
 VV I SSSSS UUUUU A A LLLLL

000 TTTT TTTT H H Y Y M M 000 TM  
 0 0 T T H H Y Y MM MM 0 0  
 0 0 T T H H Y M M 0 0  
 000 T T H H Y M M 000

Developed and Distributed by Smart City Water Inc  
 Copyright 2007 - 2022 Smart City Water Inc  
 All rights reserved.

\*\*\*\*\* S U M M A R Y O U T P U T \*\*\*\*\*

Input filename: C:\Program Files (x86)\Visual OTTHYM0 6.2\V02\voin.dat

Output filename:

C:\Users\hyu\AppData\Local\Civica\H5\2c2d2be-418b-4c4d-a4c4-d228733f752c\cb864a73-4fb4-4f10-b511-fe2fc736f640\scenario

Summary filename:  
 C:\Users\hyu\AppData\Local\Civica\XH5\e2c2d2be-418b-4c4d-a4c4-d228733f752c\cb864a73-4fb4-4f10-b511-fe2fc736f640\scenario

DATE: 05/09/2024

TIME: 03:09:19

USER:

COMMENTS: \_\_\_\_\_

\*\*\*\*\*  
 \*\* SIMULATION : Run 04 \*\*  
 \*\*\*\*\*

W/E COMMAND	HYD ID	DT	AREA	Qpeak	Tpeak	R.V.	R.C.	Qbase
		min	ha	cms	hrs	mm		cms

START @ 0.00 hrs

-----  
 READ STORM 5.0  
 [ Ptot= 91.08 mm ]  
 fname :

C:\Users\hyu\AppData\Local\Temp\41bb3133-f008-436a-8b76-c26e92215004\8677e260-0877-4303-925b-23f8544

remark: Ottawa Macdonald Cartier SCS 24 25yr

\*  
 \* CALIB STANDHYD 0072 1 5.0 0.06 0.02 12.00 86.58 0.95 0.000  
 [I%=90.0:S%= 2.00]

\*  
 \*\* Reservoir  
 OUTFLOW: 0074 1 5.0 0.06 0.00 12.00 86.43 n/a 0.000

\*  
 READ STORM 5.0  
 [ Ptot= 91.08 mm ]  
 fname :

C:\Users\hyu\AppData\Local\Temp\41bb3133-f008-436a-8b76-c26e92215004\8677e260-0877-4303-925b-23f8544

remark: Ottawa Macdonald Cartier SCS 24 25yr

\*  
 \* CALIB STANDHYD 0073 1 5.0 0.15 0.03 12.00 71.51 0.79 0.000  
 [I%=47.0:S%= 2.00]

=====  
 =====

```

V   V   I   SSSSS U   U   A   L           (v 6.2.2015)
V   V   I   SS    U   U   A A  L
V   V   I   SS    U   U   AAAAA L
V   V   I   SS    U   U   A   A  L
  W    I   SSSSS UUUUU A   A  LLLLL

```

```

000  TTTTT  TTTTT  H   H  Y   Y  M   M  000  TM
0   0   T    T    H   H  Y Y  MM MM  0   0
0   0   T    T    H   H  Y   M   M  0   0
000   T    T    H   H  Y   M   M  000

```

Developed and Distributed by Smart City Water Inc  
 Copyright 2007 - 2022 Smart City Water Inc  
 All rights reserved.

\*\*\*\*\* S U M M A R Y O U T P U T \*\*\*\*\*

Input filename: C:\Program Files (x86)\Visual OTTHYMO 6.2\V02\voin.dat

Output filename:

C:\Users\hyu\AppData\Local\Civica\XH5\e2c2d2be-418b-4c4d-a4c4-d228733f752c\3592b175-6811-4e92-acdf-1c90c60f3294\scenario

Summary filename:

C:\Users\hyu\AppData\Local\Civica\XH5\e2c2d2be-418b-4c4d-a4c4-d228733f752c\3592b175-6811-4e92-acdf-1c90c60f3294\scenario

DATE: 05/09/2024

TIME: 03:09:19

USER:

COMMENTS: \_\_\_\_\_

```

*****
** SIMULATION : Run 05          **
*****

```

W/E COMMAND	HYD ID	DT	AREA	Qpeak	Tpeak	R.V.	R.C.	Qbase
		min	ha	cms	hrs	mm		cms

START @ 0.00 hrs

```

-----
READ STORM          5.0
[ Ptot=101.52 mm ]
fname :

```

C:\Users\hyu\AppData\Local\Temp\41bb3133-f008-436a-8b76-c26e92215004\55c88cf1-c07d-4

de2-b4c7-fa9ea96

remark: Ottawa Macdonald Cartier SCS 24 50yr

```

*
* CALIB STANDHYD      0072  1  5.0   0.06   0.02 12.00  96.89 0.95   0.000
  [I%=90.0:S%= 2.00]

```

```

*
** Reservoir
OUTFLOW:              0074  1  5.0   0.06   0.01 12.08  96.72 n/a   0.000

```

```

*
  READ STORM              5.0
  [ Ptot=101.52 mm ]
  fname :

```

C:\Users\hyu\AppData\Local\Temp\41bb3133-f008-436a-8b76-c26e92215004\55c88cf1-c07d-4

de2-b4c7-fa9ea96

remark: Ottawa Macdonald Cartier SCS 24 50yr

```

*
* CALIB STANDHYD      0073  1  5.0   0.15   0.04 12.00  81.29 0.80   0.000
  [I%=47.0:S%= 2.00]

```

```

=====
=====

```

```

V  V  I  SSSSS  U  U  A  L          (v 6.2.2015)
V  V  I  SS    U  U  A  A  L
V  V  I  SS    U  U  AAAAA  L
V  V  I  SS    U  U  A  A  L
  WV  I  SSSSS  UUUUU  A  A  LLLLL

```

```

  000  TTTTT  TTTTT  H  H  Y  Y  M  M  000  TM
  0  0  T  T  H  H  Y  Y  MM  MM  0  0
  0  0  T  T  H  H  Y  M  M  0  0
  000  T  T  H  H  Y  M  M  000

```

Developed and Distributed by Smart City Water Inc  
 Copyright 2007 - 2022 Smart City Water Inc  
 All rights reserved.

\*\*\*\*\* S U M M A R Y O U T P U T \*\*\*\*\*

Input filename: C:\Program Files (x86)\Visual OTTHYMO 6.2\V02\voin.dat

Output filename:

C:\Users\hyu\AppData\Local\Civica\H5\2c2d2be-418b-4c4d-a4c4-d228733f752c\4fd264b8-2922-458d-bc51-3b763d71b179\scenario

Summary filename:

C:\Users\hyu\AppData\Local\Civica\H5\2c2d2be-418b-4c4d-a4c4-d228733f752c\4fd264b8-

2922-458d-bc51-3b763d71b179\scenario

DATE: 05/09/2024

TIME: 03:09:19

USER:

COMMENTS: \_\_\_\_\_

\*\*\*\*\*  
\*\* SIMULATION : Run 06 \*\*  
\*\*\*\*\*

W/E COMMAND	HYD ID	DT min	AREA ha	Qpeak cms	Tpeak hrs	R.V. mm	R.C.	Qbase cms
-------------	--------	-----------	------------	--------------	--------------	------------	------	--------------

START @ 0.00 hrs

-----  
READ STORM 5.0  
[ Ptot=111.87 mm ]  
fname :

C:\Users\hyu\AppData\Local\Temp\41bb3133-f008-436a-8b76-c26e92215004\20e7578-d439-4ffb-8edc-8fe2588  
remark: Ottawa Macdonald Cartier SCS 24 100yr

\*  
\* CALIB STANDHYD 0072 1 5.0 0.06 0.02 12.00 107.14 0.96 0.000  
[I%=90.0:S%= 2.00]

\*  
\*\* Reservoir  
OUTFLOW: 0074 1 5.0 0.06 0.01 12.08 106.95 n/a 0.000

\*  
READ STORM 5.0  
[ Ptot=111.87 mm ]  
fname :

C:\Users\hyu\AppData\Local\Temp\41bb3133-f008-436a-8b76-c26e92215004\20e7578-d439-4ffb-8edc-8fe2588  
remark: Ottawa Macdonald Cartier SCS 24 100yr

\*  
\* CALIB STANDHYD 0073 1 5.0 0.15 0.04 12.00 91.07 0.81 0.000  
[I%=47.0:S%= 2.00]

=====  
=====



```

V   V   I   SS   U   U   A   A   L
V   V   I   SS   U   U   AAAAA L
V   V   I   SS   U   U   A   A   L
  WV   I   SSSSS UUUUU A   A   LLLLL

```

```

000   TTTTT   TTTTT   H   H   Y   Y   M   M   000   TM
0   0   T       T   H   H   Y   Y   MM  MM  0   0
0   0   T       T   H   H   Y       M   M  0   0
000   T       T   H   H   Y       M   M  000

```

Developed and Distributed by Smart City Water Inc  
 Copyright 2007 - 2022 Smart City Water Inc  
 All rights reserved.

\*\*\*\*\* S U M M A R Y O U T P U T \*\*\*\*\*

Input filename: C:\Program Files (x86)\Visual OTTHYMO 6.2\V02\voin.dat

Output filename:

C:\Users\hyu\AppData\Local\Civica\XH5\e2c2d2be-418b-4c4d-a4c4-d228733f752c\c075116d-68fc-46b4-b92d-bff5231d098c\scenario

Summary filename:

C:\Users\hyu\AppData\Local\Civica\XH5\e2c2d2be-418b-4c4d-a4c4-d228733f752c\c075116d-68fc-46b4-b92d-bff5231d098c\scenario

DATE: 05/09/2024

TIME: 03:09:19

USER:

COMMENTS: \_\_\_\_\_

```

*****
** SIMULATION : Run 07          **
*****

```

W/E COMMAND	HYD ID	DT	AREA	Qpeak	Tpeak	R.V.	R.C.	Qbase
		min	ha	cms	hrs	mm		cms

START @ 0.00 hrs

```

-----
READ STORM          5.0
[ Ptot=134.33 mm ]
fname :

```

C:\Users\hyu\AppData\Local\Temp\41bb3133-f008-436a-8b76-c26e92215004\ac716820-7d80-4c8a-bdcd-c5f81a0

remark: Ottawa SCS 24 100yr 20% Stress Test

\*  
\* CALIB STANDHYD           0072 1 5.0    0.06    0.02 12.00 129.41 0.96    0.000  
  [I%=90.0:S%= 2.00]

\*  
\*\* Reservoir  
  OUTFLOW:                0074 1 5.0    0.06    0.01 12.08 129.19 n/a    0.000

\*  
  READ STORM                        5.0  
  [ Ptot=134.33 mm ]  
  fname :

C:\Users\hyu\AppData\Local\Temp\41bb3133-f008-436a-8b76-c26e92215004\ac716820-7d80-4c8a-bdcd-c5f81a0

  remark: Ottawa SCS 24 100yr 20% Stress Test

\*  
\* CALIB STANDHYD           0073 1 5.0    0.15    0.05 12.00 112.52 0.84    0.000  
  [I%=47.0:S%= 2.00]

\*  
  FINISH

=====  
=====

POST CHI

=====

```

V   V   I   SSSSS  U   U   A   L           (v 6.2.2015)
V   V   I   SS     U   U   A A  L
V   V   I   SS     U   U   AAAAA L
V   V   I   SS     U   U   A   A  L
  VV    I   SSSSS  UUUUU  A   A  LLLLL

```

```

  000  TTTTT  TTTTT  H   H  Y   Y  M   M   000  TM
  0   0   T    T    H   H   Y Y  MM MM  0   0
  0   0   T    T    H   H   Y   M   M  0   0
  000    T    T    H   H   Y   M   M  000

```

Developed and Distributed by Smart City Water Inc  
 Copyright 2007 - 2022 Smart City Water Inc  
 All rights reserved.

\*\*\*\*\* S U M M A R Y O U T P U T \*\*\*\*\*

Input filename: C:\Program Files (x86)\Visual OTTHYMO 6.2\V02\voin.dat

Output filename:

C:\Users\hyu\AppData\Local\Civica\VH5\e2c2d2be-418b-4c4d-a4c4-d228733f752c\ba4b3151-3434-4d95-884c-1dfe096b7b54\scenario

Summary filename:

C:\Users\hyu\AppData\Local\Civica\VH5\e2c2d2be-418b-4c4d-a4c4-d228733f752c\ba4b3151-3434-4d95-884c-1dfe096b7b54\scenario

DATE: 05/09/2024

TIME: 03:09:50

USER:

COMMENTS: \_\_\_\_\_

```

*****
** SIMULATION : Ottawa 100yr 3hr Chicago **
*****

```

W/E COMMAND	HYD ID	DT min	AREA ha	Qpeak ' cms	Tpeak hrs	R.V. mm	R.C.	Qbase cms
-------------	--------	-----------	------------	----------------	--------------	------------	------	--------------

START @ 0.00 hrs

-----

```

CHIC STORM                10.0
[ Ptot= 71.66 mm ]
*
* CALIB STANDHYD          0075  1  5.0   0.15   0.05  1.00  53.66 0.75   0.000
[ I%=47.0:S%= 2.00]
*
CHIC STORM                10.0
[ Ptot= 71.66 mm ]
*
* CALIB STANDHYD          0076  1  5.0   0.06   0.03  1.00  67.45 0.94   0.000
[ I%=90.0:S%= 2.00]
*
** Reservoir
OUTFLOW:                   0077  1  5.0   0.06   0.01  1.08  67.22 n/a   0.000
*

```

```

=====
=====

```

```

V  V  I  SSSSS  U  U  A  L                (v 6.2.2015)
V  V  I  SS    U  U  A  A  L
V  V  I  SS    U  U  AAAAA  L
V  V  I  SS    U  U  A  A  L
  VV   I  SSSSS  UUUUU  A  A  LLLLL

```

```

  000  TTTTT  TTTTT  H  H  Y  Y  M  M  000  TM
  0  0  T    T  H  H  Y  Y  MM MM  0  0
  0  0  T    T  H  H  Y    M  M  0  0
  000  T    T  H  H  Y    M  M  000

```

Developed and Distributed by Smart City Water Inc  
 Copyright 2007 - 2022 Smart City Water Inc  
 All rights reserved.

\*\*\*\*\* S U M M A R Y O U T P U T \*\*\*\*\*

Input filename: C:\Program Files (x86)\Visual OTTHYMO 6.2\V02\voin.dat

Output filename:

C:\Users\hyu\AppData\Local\Civica\VH5\e2c2d2be-418b-4c4d-a4c4-d228733f752c\89d27013-c96f-46e4-82e5-cbf43459bb00\scenario

Summary filename:

C:\Users\hyu\AppData\Local\Civica\VH5\e2c2d2be-418b-4c4d-a4c4-d228733f752c\89d27013-c96f-46e4-82e5-cbf43459bb00\scenario

DATE: 05/09/2024

TIME: 03:09:50

USER:

COMMENTS: \_\_\_\_\_

\*\*\*\*\*  
 \*\* SIMULATION : Ottawa 100yr 6hr Chicago \*\*  
 \*\*\*\*\*

W/E COMMAND	HYD ID	DT min	AREA ha	Qpeak cms	Tpeak hrs	R.V. mm	R.C.	Qbase cms
START @ 0.00 hrs								
-----								
CHIC STORM			10.0					
[ Ptot= 82.32 mm ]								
* CALIB STANDHYD	0075	1 5.0	0.15	0.05	2.00	63.40	0.77	0.000
[ I%=47.0:S%= 2.00 ]								
* CHIC STORM			10.0					
[ Ptot= 82.32 mm ]								
* CALIB STANDHYD	0076	1 5.0	0.06	0.03	2.00	77.94	0.95	0.000
[ I%=90.0:S%= 2.00 ]								
** Reservoir								
OUTFLOW:	0077	1 5.0	0.06	0.01	2.08	77.69	n/a	0.000

=====

```

V V I SSSSS U U A L (v 6.2.2015)
V V I SS U U A A L
V V I SS U U AAAAA L
V V I SS U U A A L
VV I SSSSS UUUUU A A LLLLL

```

```

000 TTTT TTTT H H Y Y M M 000 TM
O O T T H H Y Y MM MM O O
O O T T H H Y M M O O
000 T T H H Y M M 000

```

Developed and Distributed by Smart City Water Inc  
 Copyright 2007 - 2022 Smart City Water Inc  
 All rights reserved.

\*\*\*\*\* SUMMARY OUTPUT \*\*\*\*\*

Input filename: C:\Program Files (x86)\Visual OTTHYMO 6.2\V02\voin.dat

Output filename:

C:\Users\hyu\AppData\Local\Civica\XH5\e2c2d2be-418b-4c4d-a4c4-d228733f752c\5703c5e9-c776-4ba0-8427-c7f9914e66d9\scenario

Summary filename:

C:\Users\hyu\AppData\Local\Civica\XH5\e2c2d2be-418b-4c4d-a4c4-d228733f752c\5703c5e9-c776-4ba0-8427-c7f9914e66d9\scenario

DATE: 05/09/2024

TIME: 03:09:50

USER:

COMMENTS: \_\_\_\_\_

\*\*\*\*\*  
\*\* SIMULATION : Ottawa 2yr 3hr Chicago \*\*  
\*\*\*\*\*

W/E COMMAND	HYD ID	DT	AREA	Qpeak	Tpeak	R.V.	R.C.	Qbase
		min	ha	cms	hrs	mm		cms
START @ 0.00 hrs								
-----								
CHIC STORM			10.0					
[ Ptot= 31.86 mm ]								
* CALIB STANDHYD	0075	1 5.0	0.15	0.02	1.00	19.52	0.61	0.000
[ I%=47.0:S%= 2.00 ]								
* CHIC STORM			10.0					
[ Ptot= 31.86 mm ]								
* CALIB STANDHYD	0076	1 5.0	0.06	0.01	1.00	28.73	0.90	0.000
[ I%=90.0:S%= 2.00 ]								
** Reservoir								
OUTFLOW:	0077	1 5.0	0.06	0.00	1.08	28.51	n/a	0.000

=====  
=====

V V I SSSSS U U A L (v 6.2.2015)  
V V I SS U U A A L  
V V I SS U U AAAAA L



\*  
 \* CALIB STANDHYD 0076 1 5.0 0.06 0.01 2.00 33.54 0.91 0.000  
 [I%=90.0:S%= 2.00]

\*  
 \*\* Reservoir  
 OUTFLOW: 0077 1 5.0 0.06 0.00 2.08 33.36 n/a 0.000  
 \*

=====  
 =====

V V I SSSSS U U A L (v 6.2.2015)  
 V V I SS U U A A L  
 V V I SS U U AAAAA L  
 V V I SS U U A A L  
 VV I SSSSS UUUUU A A LLLLL

000 TTTTT TTTTT H H Y Y M M 000 TM  
 0 0 T T H H Y Y MM MM 0 0  
 0 0 T T H H Y M M 0 0  
 000 T T H H Y M M 000

Developed and Distributed by Smart City Water Inc  
 Copyright 2007 - 2022 Smart City Water Inc  
 All rights reserved.

\*\*\*\*\* S U M M A R Y O U T P U T \*\*\*\*\*

Input filename: C:\Program Files (x86)\Visual OTTHYMO 6.2\V02\voin.dat

Output filename:  
 C:\Users\hyu\AppData\Local\Civica\VH5\e2c2d2be-418b-4c4d-a4c4-d228733f752c\64885d31-5a4d-48cc-91cc-4712f0456eb5\scenario

Summary filename:  
 C:\Users\hyu\AppData\Local\Civica\VH5\e2c2d2be-418b-4c4d-a4c4-d228733f752c\64885d31-5a4d-48cc-91cc-4712f0456eb5\scenario

DATE: 05/09/2024 TIME: 03:09:50

USER:

COMMENTS: \_\_\_\_\_

\*\*\*\*\*  
 \*\* SIMULATION : Ottawa CHI 3hr 100yr 20% Stre \*\*  
 \*\*\*\*\*



W/E COMMAND	HYD ID	DT min	AREA ha	Qpeak cms	Tpeak hrs	R.V. mm	R.C.	Qbase cms
-------------	--------	-----------	------------	--------------	--------------	------------	------	--------------

START @ 0.00 hrs

-----  
 READ STORM 10.0

[ Ptot= 86.00 mm ]

fname :

C:\Users\hyu\AppData\Local\Temp\896eebbf-9d35-4796-9dac-4c6cd2dd0099\32b7fd0c-15ca-4f9c-b1e2-85aecb

remark: Ottawa CHI 3hr 100yr 20% Stress Test

\*

* CALIB STANDHYD	0075	1	5.0	0.15	0.06	1.00	66.80	0.78	0.000
------------------	------	---	-----	------	------	------	-------	------	-------

[ I%=47.0:S%= 2.00 ]

\*

READ STORM 10.0

[ Ptot= 86.00 mm ]

fname :

C:\Users\hyu\AppData\Local\Temp\896eebbf-9d35-4796-9dac-4c6cd2dd0099\32b7fd0c-15ca-4f9c-b1e2-85aecb

remark: Ottawa CHI 3hr 100yr 20% Stress Test

\*

* CALIB STANDHYD	0076	1	5.0	0.06	0.03	1.00	81.56	0.95	0.000
------------------	------	---	-----	------	------	------	-------	------	-------

[ I%=90.0:S%= 2.00 ]

\*

\*\* Reservoir

OUTFLOW:	0077	1	5.0	0.06	0.01	1.17	81.31	n/a	0.000
----------	------	---	-----	------	------	------	-------	-----	-------

\*

FINISH

=====

=====

=====

=====

V	V	I	SSSSS	U	U	A	L				(v 6.2.2015)
V	V	I	SS	U	U	A	A	L			
V	V	I	SS	U	U	AAAAA	L				
V	V	I	SS	U	U	A	A	L			
VV	I	SSSSS	UUUUU	A	A	LLLLL					

000	TTTTT	TTTTT	H	H	Y	Y	M	M	000	TM	
0	0	T	T	H	H	Y	Y	MM	MM	0	0
0	0	T	T	H	H	Y	M	M	0	0	
000	T	T	H	H	Y	M	M	000			

Developed and Distributed by Smart City Water Inc  
Copyright 2007 - 2022 Smart City Water Inc  
All rights reserved.

\*\*\*\*\* S U M M A R Y O U T P U T \*\*\*\*\*

Input filename: C:\Program Files (x86)\Visual OTTHYMO 6.2\V02\voin.dat

Output filename:

C:\Users\hyu\AppData\Local\Civica\XH5\e2c2d2be-418b-4c4d-a4c4-d228733f752c\7c3b46f1-b133-4e8d-a9e6-50060f8d4d55\scenario

Summary filename:

C:\Users\hyu\AppData\Local\Civica\XH5\e2c2d2be-418b-4c4d-a4c4-d228733f752c\7c3b46f1-b133-4e8d-a9e6-50060f8d4d55\scenario

DATE: 05/09/2024

TIME: 03:09:50

USER:

COMMENTS: \_\_\_\_\_

\*\*\*\*\*  
\*\* SIMULATION : Ottawa CHI 6hr 100yr 20% Stre \*\*  
\*\*\*\*\*

W/E COMMAND	HYD ID	DT min	AREA ha	Qpeak cms	Tpeak hrs	R.V. mm	R.C.	Qbase cms
-------------	--------	-----------	------------	--------------	--------------	------------	------	--------------

START @ 0.00 hrs

-----

READ STORM 10.0

[ Ptot= 98.79 mm ]

fname :

C:\Users\hyu\AppData\Local\Temp\896eebbf-9d35-4796-9dac-4c6cd2dd0099\6194acba-bf2a-4854-b4ec-26c008a

remark: Ottawa CHI 6hr 100yr 20% Stress Test

\*

* CALIB STANDHYD	0075	1	5.0	0.15	0.06	2.00	78.72	0.80	0.000
------------------	------	---	-----	------	------	------	-------	------	-------

[ I%=47.0:S%= 2.00 ]

\*

READ STORM 10.0

[ Ptot= 98.79 mm ]

fname :

C:\Users\hyu\AppData\Local\Temp\896eebbf-9d35-4796-9dac-4c6cd2dd0099\6194acba-bf2a-4

854-b4ec-26c008a

remark: Ottawa CHI 6hr 100yr 20% Stress Test

\*

* CALIB STANDHYD	0076	1	5.0	0.06	0.03	2.00	94.19	0.95	0.000
------------------	------	---	-----	------	------	------	-------	------	-------

[I%=90.0:S%= 2.00]

\*

** Reservoir									
OUTFLOW:	0077	1	5.0	0.06	0.01	2.17	93.99	n/a	0.000

\*

# Stormceptor<sup>®</sup> EF Sizing Report

## STORMCEPTOR<sup>®</sup> ESTIMATED NET ANNUAL SEDIMENT (TSS) LOAD REDUCTION

05/29/2023

Province:	Ontario
City:	Ottawa
Nearest Rainfall Station:	OTTAWA CDA RCS
Climate Station Id:	6105978
Years of Rainfall Data:	20

Project Name:	5497 Manotick Main Street
Project Number:	522679
Designer Name:	Guillaume Courtois
Designer Company:	Tatham Engineering
Designer Email:	gcourtois@tathameng.com
Designer Phone:	613-747-3636
EOR Name:	
EOR Company:	
EOR Email:	
EOR Phone:	

Site Name:	
------------	--

Drainage Area (ha):	0.06
% Imperviousness:	90.00

Runoff Coefficient 'c': 0.84

Particle Size Distribution:	Fine
Target TSS Removal (%):	80.0

Required Water Quality Runoff Volume Capture (%):	90.00
Estimated Water Quality Flow Rate (L/s):	1.63
Oil / Fuel Spill Risk Site?	Yes
Upstream Flow Control?	Yes
Upstream Orifice Control Flow Rate to Stormceptor (L/s):	7.00
Peak Conveyance (maximum) Flow Rate (L/s):	
Site Sediment Transport Rate (kg/ha/yr):	

### Net Annual Sediment (TSS) Load Reduction Sizing Summary

Stormceptor Model	TSS Removal Provided (%)
EFO4	99
EFO6	100
EFO8	100
EFO10	100
EFO12	100

**Recommended Stormceptor EFO Model: EFO4**  
**Estimated Net Annual Sediment (TSS) Load Reduction (%): 99**  
**Water Quality Runoff Volume Capture (%): > 90**

## Stormceptor® EF Sizing Report

### THIRD-PARTY TESTING AND VERIFICATION

► **Stormceptor® EF and Stormceptor® EFO** are the latest evolutions in the Stormceptor® oil-grit separator (OGS) technology series, and are designed to remove a wide variety of pollutants from stormwater and snowmelt runoff. These technologies have been third-party tested in accordance with the Canadian ETV **Procedure for Laboratory Testing of Oil-Grit Separators** and performance has been third-party verified in accordance with the **ISO 14034 Environmental Technology Verification (ETV)** protocol.

### PERFORMANCE

► **Stormceptor® EF and EFO** remove stormwater pollutants through gravity separation and floatation, and feature a patent-pending design that generates positive removal of total suspended solids (TSS) throughout each storm event, including high-intensity storms. Captured pollutants include sediment, free oils, and sediment-bound pollutants such as nutrients, heavy metals, and petroleum hydrocarbons. Stormceptor is sized to remove a high level of TSS from the frequent rainfall events that contribute the vast majority of annual runoff volume and pollutant load. The technology incorporates an internal bypass to convey excessive stormwater flows from high-intensity storms through the device without resuspension and washout (scour) of previously captured pollutants. Proper routine maintenance ensures high pollutant removal performance and protection of downstream waterways.

### PARTICLE SIZE DISTRIBUTION (PSD)

► The **Canadian ETV PSD** shown in the table below was used, or in part, for this sizing. This is the identical PSD that is referenced in the Canadian ETV **Procedure for Laboratory Testing of Oil-Grit Separators** for both sediment removal testing and scour testing. The Canadian ETV PSD contains a wide range of particle sizes in the sand and silt fractions, and is considered reasonably representative of the particle size fractions found in typical urban stormwater runoff.

Particle Size (µm)	Percent Less Than	Particle Size Fraction (µm)	Percent
1000	100	500-1000	5
500	95	250-500	5
250	90	150-250	15
150	75	100-150	15
100	60	75-100	10
75	50	50-75	5
50	45	20-50	10
20	35	8-20	15
8	20	5-8	10
5	10	2-5	5
2	5	<2	5



## Stormceptor<sup>®</sup> EF Sizing Report

### Upstream Flow Controlled Results

Rainfall Intensity (mm / hr)	Percent Rainfall Volume (%)	Cumulative Rainfall Volume (%)	Flow Rate (L/s)	Flow Rate (L/min)	Surface Loading Rate (L/min/m <sup>2</sup> )	Removal Efficiency (%)	Incremental Removal (%)	Cumulative Removal (%)
0.5	8.6	8.6	0.07	4.0	4.0	100	8.6	8.6
1	20.3	29.0	0.14	8.0	7.0	100	20.3	29.0
2	16.2	45.2	0.28	17.0	14.0	100	16.2	45.2
3	12.0	57.2	0.42	25.0	21.0	100	12.0	57.2
4	8.4	65.6	0.56	34.0	28.0	100	8.4	65.6
5	5.9	71.6	0.70	42.0	35.0	100	5.9	71.6
6	4.6	76.2	0.84	50.0	42.0	100	4.6	76.2
7	3.1	79.3	0.98	59.0	49.0	100	3.1	79.3
8	2.7	82.0	1.12	67.0	56.0	100	2.7	82.0
9	3.3	85.3	1.26	76.0	63.0	100	3.3	85.3
10	2.3	87.6	1.40	84.0	70.0	100	2.3	87.6
11	1.6	89.2	1.54	92.0	77.0	100	1.6	89.2
12	1.3	90.5	1.68	101.0	84.0	98	1.3	90.5
13	1.7	92.2	1.82	109.0	91.0	97	1.7	92.2
14	1.2	93.5	1.96	118.0	98.0	97	1.2	93.4
15	1.2	94.6	2.10	126.0	105.0	96	1.1	94.5
16	0.7	95.3	2.24	135.0	112.0	95	0.7	95.1
17	0.7	96.1	2.38	143.0	119.0	93	0.7	95.8
18	0.4	96.5	2.52	151.0	126.0	93	0.4	96.2
19	0.4	96.9	2.66	160.0	133.0	92	0.4	96.6
20	0.2	97.1	2.80	168.0	140.0	91	0.2	96.8
21	0.5	97.5	2.94	177.0	147.0	91	0.4	97.2
22	0.2	97.8	3.08	185.0	154.0	89	0.2	97.4
23	1.0	98.8	3.22	193.0	161.0	88	0.9	98.3
24	0.3	99.1	3.36	202.0	168.0	88	0.2	98.5
25	0.9	100.0	3.50	210.0	175.0	87	0.8	99.3
30	0.9	100.9	4.20	252.0	210.0	83	0.8	100.1
35	-0.9	100.0	4.90	294.0	245.0	81	N/A	99.4
40	0.0	100.0	5.60	336.0	280.0	79	0.0	99.4
45	0.0	100.0	6.31	378.0	315.0	78	0.0	99.4
<b>Estimated Net Annual Sediment (TSS) Load Reduction =</b>								<b>99 %</b>

Climate Station ID: 6105978 Years of Rainfall Data: 20

**Stormceptor® EF Sizing Report**

**RAINFALL DATA FROM OTTAWA CDA RCS RAINFALL STATION**

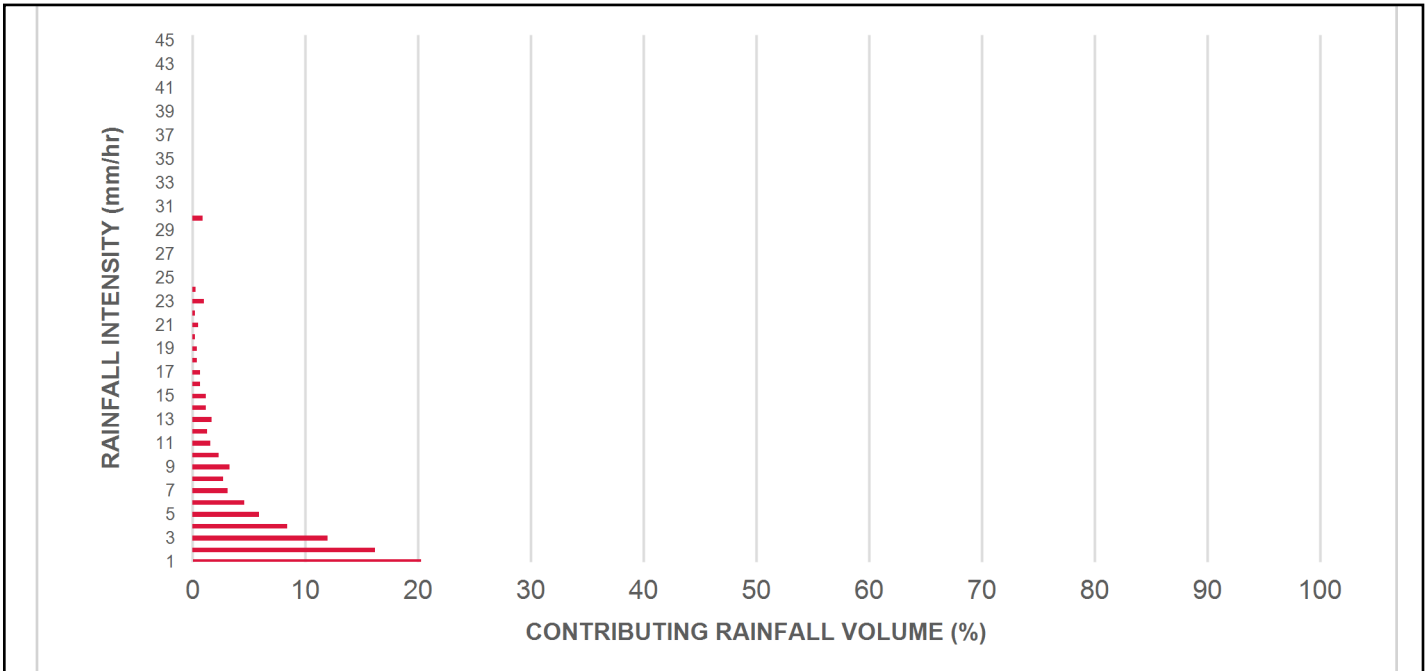

**INCREMENTAL AND CUMULATIVE TSS REMOVAL FOR THE RECOMMENDED STORMCEPTOR® MODEL**

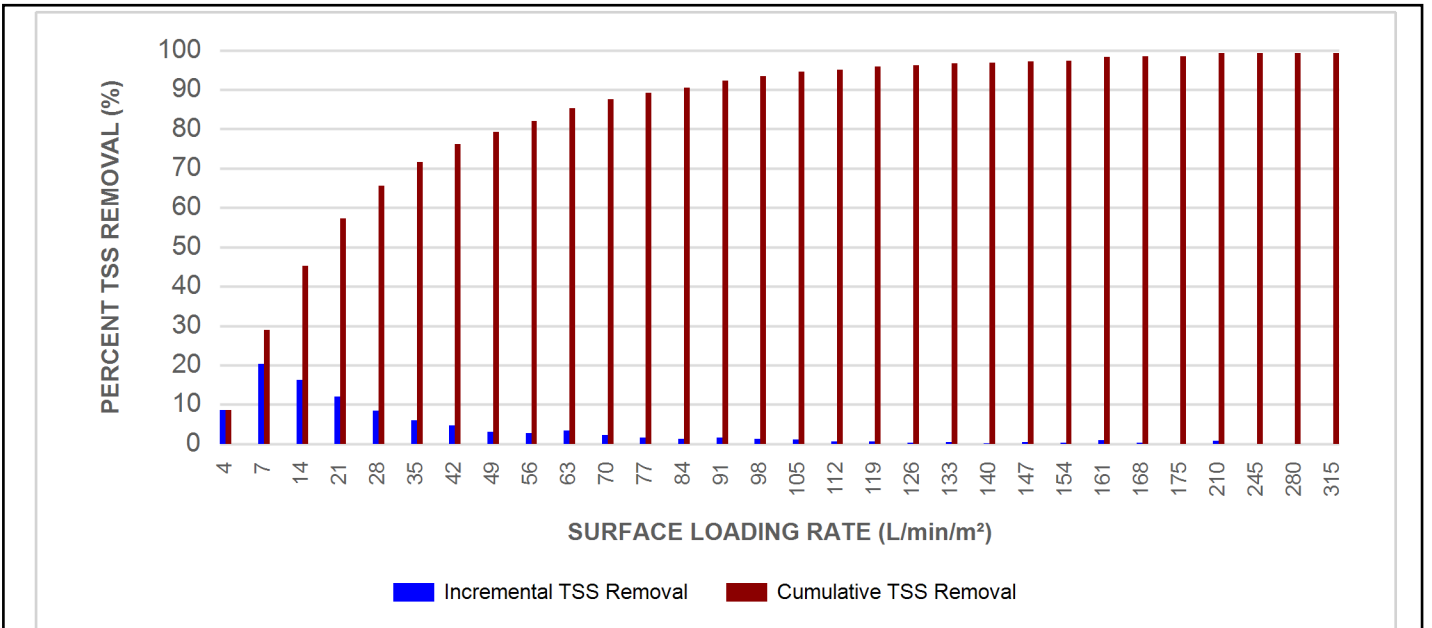

## Stormceptor® EF Sizing Report

### Maximum Pipe Diameter / Peak Conveyance

Stormceptor EF / EFO	Model Diameter		Min Angle Inlet / Outlet Pipes	Max Inlet Pipe Diameter		Max Outlet Pipe Diameter		Peak Conveyance Flow Rate	
	(m)	(ft)		(mm)	(in)	(mm)	(in)	(L/s)	(cfs)
EF4 / EFO4	1.2	4	90	609	24	609	24	425	15
EF6 / EFO6	1.8	6	90	914	36	914	36	990	35
EF8 / EFO8	2.4	8	90	1219	48	1219	48	1700	60
EF10 / EFO10	3.0	10	90	1828	72	1828	72	2830	100
EF12 / EFO12	3.6	12	90	1828	72	1828	72	2830	100

### SCOUR PREVENTION AND ONLINE CONFIGURATION

► **Stormceptor® EF and EFO** feature an internal bypass and superior scour prevention technology that have been demonstrated in third-party testing according to the scour testing provisions of the Canadian ETV **Procedure for Laboratory Testing of Oil-Grit Separators**, and the exceptional scour test performance has been third-party verified in accordance with the ISO 14034 ETV protocol. As a result, Stormceptor EF and EFO are approved for online installation, eliminating the need for costly additional bypass structures, piping, and installation expense.

### DESIGN FLEXIBILITY

► **Stormceptor® EF and EFO** offers design flexibility in one simplified platform, accepting stormwater flow from a single inlet pipe or multiple inlet pipes, and/or surface runoff through an inlet grate. The device can also serve as a junction structure, accommodate a 90-degree inlet-to-outlet bend angle, and can be modified to ensure performance in submerged conditions.

### OIL CAPTURE AND RETENTION

► While Stormceptor® EF will capture and retain oil from dry weather spills and low intensity runoff, **Stormceptor® EFO** has demonstrated superior oil capture and greater than 99% oil retention in third-party testing according to the light liquid re-entrainment testing provisions of the Canadian ETV **Procedure for Laboratory Testing of Oil-Grit Separators**. Stormceptor EFO is recommended for sites where oil capture and retention is a requirement.

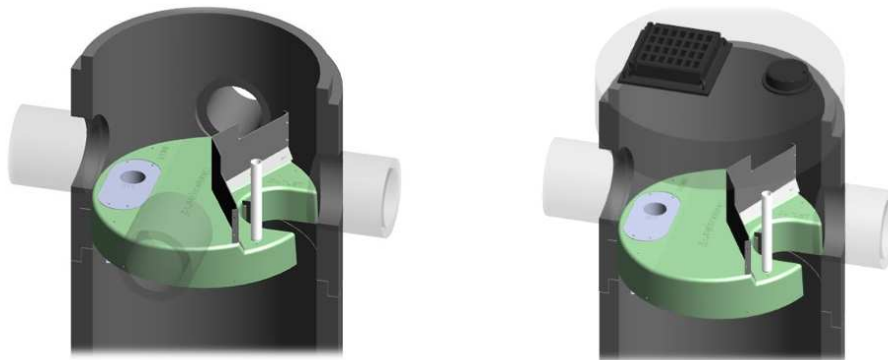



## Stormceptor® EF Sizing Report

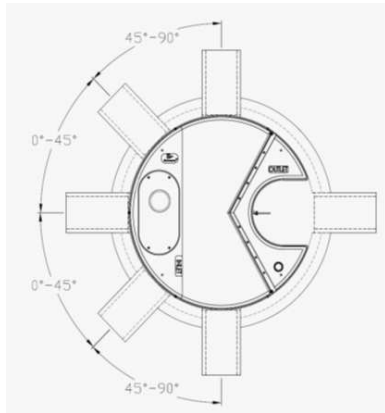

### INLET-TO-OUTLET DROP

Elevation differential between inlet and outlet pipe inverts is dictated by the angle at which the inlet pipe(s) enters the unit.

0° - 45° : The inlet pipe is 1-inch (25mm) higher than the outlet pipe.

45° - 90° : The inlet pipe is 2-inches (50mm) higher than the outlet pipe.

### HEAD LOSS

The head loss through Stormceptor EF is similar to that of a 60-degree bend structure. The applicable K value for calculating minor losses through the unit is 1.1.

For submerged conditions the applicable K value is 3.0.

### Pollutant Capacity

Stormceptor EF / EFO	Model Diameter		Depth (Outlet Pipe Invert to Sump Floor)		Oil Volume		Recommended Sediment Maintenance Depth *		Maximum Sediment Volume *		Maximum Sediment Mass **	
	(m)	(ft)	(m)	(ft)	(L)	(Gal)	(mm)	(in)	(L)	(ft³)	(kg)	(lb)
EF4 / EFO4	1.2	4	1.52	5.0	265	70	203	8	1190	42	1904	5250
EF6 / EFO6	1.8	6	1.93	6.3	610	160	305	12	3470	123	5552	15375
EF8 / EFO8	2.4	8	2.59	8.5	1070	280	610	24	8780	310	14048	38750
EF10 / EFO10	3.0	10	3.25	10.7	1670	440	610	24	17790	628	28464	78500
EF12 / EFO12	3.6	12	3.89	12.8	2475	655	610	24	31220	1103	49952	137875

\*Increased sump depth may be added to increase sediment storage capacity

\*\* Average density of wet packed sediment in sump = 1.6 kg/L (100 lb/ft³)

Feature	Benefit	Feature Appeals To
Patent-pending enhanced flow treatment and scour prevention technology	Superior, verified third-party performance	Regulator, Specifying & Design Engineer
Third-party verified light liquid capture and retention for EFO version	Proven performance for fuel/oil hotspot locations	Regulator, Specifying & Design Engineer, Site Owner
Functions as bend, junction or inlet structure	Design flexibility	Specifying & Design Engineer
Minimal drop between inlet and outlet	Site installation ease	Contractor
Large diameter outlet riser for inspection and maintenance	Easy maintenance access from grade	Maintenance Contractor & Site Owner

### STANDARD STORMCEPTOR EF/EFO DRAWINGS

For standard details, please visit <http://www.imbriumsystems.com/stormwater-treatment-solutions/stormceptor-ef>

### STANDARD STORMCEPTOR EF/EFO SPECIFICATION

For specifications, please visit <http://www.imbriumsystems.com/stormwater-treatment-solutions/stormceptor-ef>

## Stormceptor<sup>®</sup> EF Sizing Report

# STANDARD PERFORMANCE SPECIFICATION FOR “OIL GRIT SEPARATOR” (OGS) STORMWATER QUALITY TREATMENT DEVICE

## PART 1 – GENERAL

### 1.1 WORK INCLUDED

This section specifies requirements for selecting, sizing, and designing an underground Oil Grit Separator (OGS) device for stormwater quality treatment, with third-party testing results and a Statement of Verification in accordance with ISO 14034 Environmental Management – Environmental Technology Verification (ETV).

### 1.2 REFERENCE STANDARDS & PROCEDURES

ISO 14034:2016 Environmental management – Environmental technology verification (ETV)

Canadian Environmental Technology Verification (ETV) Program’s **Procedure for Laboratory Testing of Oil-Grit Separators**

### 1.3 SUBMITTALS

1.3.1 All submittals, including sizing reports & shop drawings, shall be submitted upon request with each order to the contractor then forwarded to the Engineer of Record for review and acceptance. Shop drawings shall detail all OGS components, elevations, and sequence of construction.

1.3.2 Alternative devices shall have features identical to or greater than the specified device, including: treatment chamber diameter, treatment chamber wet volume, sediment storage volume, and oil storage volume.

1.3.3 Unless directed otherwise by the Engineer of Record, OGS stormwater quality treatment product substitutions or alternatives submitted within ten days prior to project bid shall not be accepted. All alternatives or substitutions submitted shall be signed and sealed by a local registered Professional Engineer, based on the exact same criteria detailed in Section 3, in entirety, subject to review and approval by the Engineer of Record.

## PART 2 – PRODUCTS

### 2.1 OGS POLLUTANT STORAGE

The OGS device shall include a sump for sediment storage, and a protected volume for the capture and storage of petroleum hydrocarbons and buoyant gross pollutants. The minimum sediment & petroleum hydrocarbon storage capacity shall be as follows:

2.1.1	4 ft (1219 mm) Diameter OGS Units:	1.19 m <sup>3</sup> sediment / 265 L oil
	6 ft (1829 mm) Diameter OGS Units:	3.48 m <sup>3</sup> sediment / 609 L oil
	8 ft (2438 mm) Diameter OGS Units:	8.78 m <sup>3</sup> sediment / 1,071 L oil
	10 ft (3048 mm) Diameter OGS Units:	17.78 m <sup>3</sup> sediment / 1,673 L oil
	12 ft (3657 mm) Diameter OGS Units:	31.23 m <sup>3</sup> sediment / 2,476 L oil

## PART 3 – PERFORMANCE & DESIGN

### 3.1 GENERAL

The OGS stormwater quality treatment device shall be verified in accordance with ISO 14034:2016 Environmental management – Environmental technology verification (ETV). The OGS stormwater quality treatment device shall



## Stormceptor<sup>®</sup> EF Sizing Report

remove oil, sediment and gross pollutants from stormwater runoff during frequent wet weather events, and retain these pollutants during less frequent high flow wet weather events below the insert within the OGS for later removal during maintenance. The Manufacturer shall have at least ten (10) years of local experience, history and success in engineering design, manufacturing and production and supply of OGS stormwater quality treatment device systems, acceptable to the Engineer of Record.

### 3.2 SIZING METHODOLOGY

The OGS device shall be engineered, designed and sized to provide stormwater quality treatment based on treating a minimum of 90 percent of the average annual runoff volume and a minimum removal of an annual average 60% of the sediment (TSS) load based on the Particle Size Distribution (PSD) specified in the sizing report for the specified device. Sizing of the OGS shall be determined by use of a minimum ten (10) years of local historical rainfall data provided by Environment Canada. Sizing shall also be determined by use of the sediment removal performance data derived from the ISO 14034 ETV third-party verified laboratory testing data from testing conducted in accordance with the Canadian ETV protocol Procedure for Laboratory Testing of Oil-Grit Separators, as follows:

3.2.1 Sediment removal efficiency for a given surface loading rate and its associated flow rate shall be based on sediment removal efficiency demonstrated at the seven (7) tested surface loading rates specified in the protocol, ranging 40 L/min/m<sup>2</sup> to 1400 L/min/m<sup>2</sup>, and as stated in the ISO 14034 ETV Verification Statement for the OGS device.

3.2.2 Sediment removal efficiency for surface loading rates between 40 L/min/m<sup>2</sup> and 1400 L/min/m<sup>2</sup> shall be based on linear interpolation of data between consecutive tested surface loading rates.

3.2.3 Sediment removal efficiency for surface loading rates less than the lowest tested surface loading rate of 40 L/min/m<sup>2</sup> shall be assumed to be identical to the sediment removal efficiency at 40 L/min/m<sup>2</sup>. No extrapolation shall be allowed that results in a sediment removal efficiency that is greater than that demonstrated at 40 L/min/m<sup>2</sup>.

3.2.4 Sediment removal efficiency for surface loading rates greater than the highest tested surface loading rate of 1400 L/min/m<sup>2</sup> shall assume zero sediment removal for the portion of flow that exceeds 1400 L/min/m<sup>2</sup>, and shall be calculated using a simple proportioning formula, with 1400 L/min/m<sup>2</sup> in the numerator and the higher surface loading rate in the denominator, and multiplying the resulting fraction times the sediment removal efficiency at 1400 L/min/m<sup>2</sup>.

The OGS device shall also have sufficient annual sediment storage capacity as specified and calculated in Section 2.1.

### 3.3 CANADIAN ETV or ISO 14034 ETV VERIFICATION OF SCOUR TESTING

The OGS device shall have Canadian ETV or ISO 14034 ETV Verification of third-party scour testing conducted in accordance with the Canadian ETV Program's **Procedure for Laboratory Testing of Oil-Grit Separators**.

3.3.1 To be acceptable for on-line installation, the OGS device must demonstrate an average scour test effluent concentration less than 10 mg/L at each surface loading rate tested, up to and including 2600 L/min/m<sup>2</sup>.

### 3.4 LIGHT LIQUID RE-ENTRAINMENT SIMULATION TESTING

The OGS device shall have Canadian ETV or ISO 14034 ETV Verification of completed third-party Light Liquid Re-entrainment Simulation Testing in accordance with the Canadian ETV **Program's Procedure for Laboratory Testing of Oil-Grit Separators**, with results reported within the Canadian ETV or ISO 14034 ETV verification. This re-entrainment testing is conducted with the device pre-loaded with low density polyethylene (LDPE) plastic beads as a surrogate for light liquids such as oil and fuel. Testing is conducted on the same OGS unit tested for sediment removal to

## Stormceptor<sup>®</sup> EF Sizing Report

assess whether light liquids captured after a spill are effectively retained at high flow rates.

3.4.1 For an OGS device to be an acceptable stormwater treatment device on a site where vehicular traffic occurs and the potential for an oil or fuel spill exists, the OGS device must have reported verified performance results of greater than 99% cumulative retention of LDPE plastic beads for the five specified surface loading rates (ranging 200 L/min/m<sup>2</sup> to 2600 L/min/m<sup>2</sup>) in accordance with the Light Liquid Re-entrainment Simulation Testing within the Canadian ETV Program's **Procedure for Laboratory Testing of Oil-Grit Separators**. However, an OGS device shall not be allowed if the Light Liquid Re-entrainment Simulation Testing was performed with screening components within the OGS device that are effective at retaining the LDPE plastic beads, but would not be expected to retain light liquids such as oil and fuel.

# VERIFICATION STATEMENT

## GLOBE Performance Solutions

Verifies the performance of

### Stormceptor® EF4 and EFO4 Oil-Grit Separators

Developed by Imbrium Systems, Inc.,  
Whitby, Ontario, Canada

In accordance with

## ISO 14034:2016

**Environmental management —  
Environmental technology verification (ETV)**



---

John D. Wiebe, PhD  
Executive Chairman  
GLOBE Performance Solutions



November 10, 2017  
Vancouver, BC, Canada

Verification Body  
GLOBE Performance Solutions  
404 – 999 Canada Place | Vancouver, B.C | Canada | V6C 3E2

## Technology description and application

The Stormceptor® EF4 and EFO4 are treatment devices designed to remove oil, sediment, trash, debris, and pollutants attached to particulates from Stormwater and snowmelt runoff. The device takes the place of a conventional manhole within a storm drain system and offers design flexibility that works with various site constraints. The EFO4 is designed with a shorter bypass weir height, which accepts lower surface loading rate into the sump, thereby reducing re-entrainment of captured free floating light liquids.

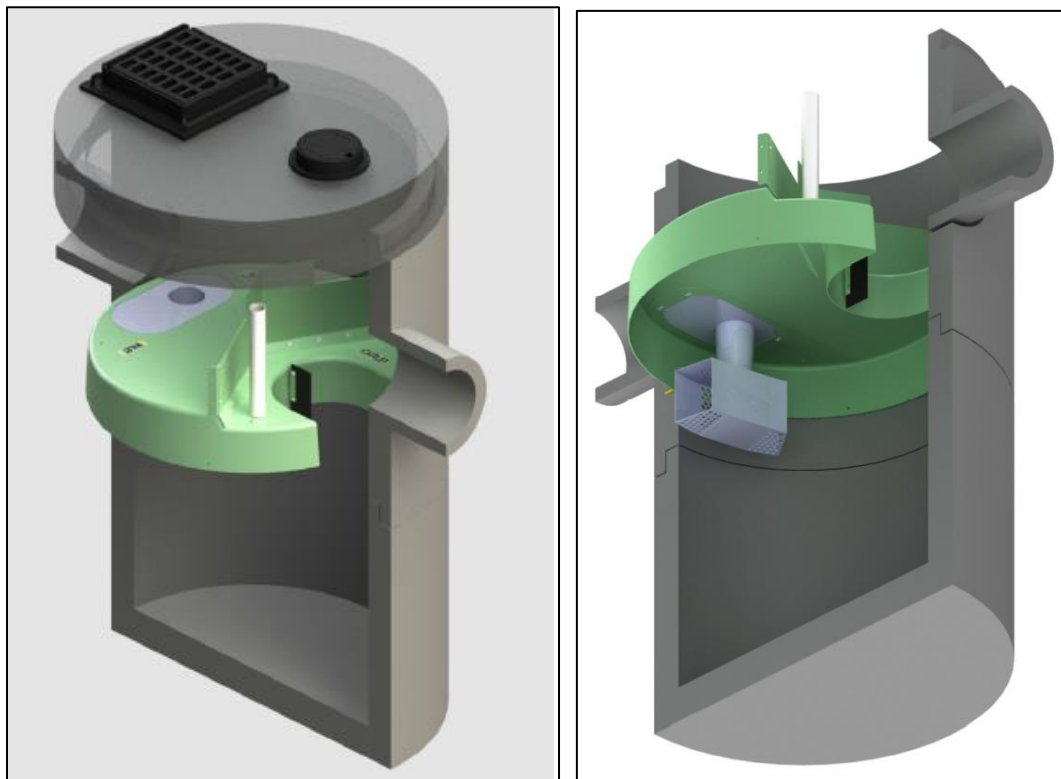

Figure 1. Graphic of typical inline Stormceptor® unit and core components.

Stormwater and snowmelt runoff enters the Stormceptor® EF/EFO's upper chamber through the inlet pipe(s) or a surface inlet grate. An insert divides the unit into lower and upper chambers and incorporates a weir to reduce influent velocity and separate influent (untreated) from effluent (treated) flows. Influent water ponds upstream of the insert's weir providing driving head for the water flowing downwards into the drop pipe where a vortex pulls the water into the lower chamber. The water diffuses at lower velocities in multiple directions through the drop pipe outlet openings. Oil and other floatables rise up and are trapped beneath the insert, while sediments undergo gravitational settling to the sump's bottom. Water from the sump can exit by flowing upward to the outlet riser onto the top side of the insert and downstream of the weir, where it discharges through the outlet pipe.

Maximum flow rate into the lower chamber is a function of weir height and drop pipe orifice diameter. The Stormceptor® EF and EFO are designed to allow a surface loading rate of 1135 L/min/m<sup>2</sup> (27.9 gal/min/ft<sup>2</sup>) and 535 L/min/m<sup>2</sup> (13.1 gal/min/ft<sup>2</sup>) into the lower chamber, respectively. When prescribed surface loading rates are exceeded, ponding water can overtop the weir height and bypass the lower treatment chamber, exiting directly through the outlet pipe. Hydraulic testing and scour testing demonstrate that the internal bypass effectively prevents scour at all bypass flow rates. Increasing the bypass flow rate does not increase the orifice-controlled flow rate into the lower treatment chamber where sediment is stored. This internal bypass feature allows for in-line installation, avoiding the cost of

additional bypass structures. During bypass, treatment continues in the lower chamber at the maximum flow rate. The Stormceptor® EFO's lower design surface loading rate is favorable for minimizing re-entrainment and washout of captured light liquids. Inspection of Stormceptor® EF and EFO devices is performed from grade by inserting a sediment probe through the outlet riser and an oil dipstick through the oil inspection pipe. The unit can be maintained by using a vacuum hose through the outlet riser.

## Performance conditions

The data and results published in this Technology Fact Sheet were obtained from the testing program conducted on the Imbrium Systems Inc.'s Stormceptor® OGS device, in accordance with the Procedure for Laboratory Testing of Oil-Grit Separators (Version 3.0, June 2014). The Procedure was prepared by the Toronto and Region Conservation Authority (TRCA) for Environment Canada's Environmental Technology Verification (ETV) Program. A copy of the Procedure may be accessed on the Canadian ETV website at [www.etvcanada.ca](http://www.etvcanada.ca).

## Performance claim(s)

### Capture test<sup>a</sup>:

During the capture test, the Stormceptor® EF OGS device, with a false floor set to 50% of the manufacturer's recommended maximum sediment storage depth and a constant influent test sediment concentration of 200 mg/L, removes 70, 64, 54, 48, 46, 44, and 49 percent of influent sediment by mass at surface loading rates of 40, 80, 200, 400, 600, 1000, and 1400 L/min/m<sup>2</sup>, respectively.

Stormceptor® EFO, with a false floor set to 50% of the manufacturer's recommended maximum sediment storage depth and a constant influent test sediment concentration of 200 mg/L, removes 70, 64, 54, 48, 42, 40, and 34 percent of influent sediment by mass at surface loading rates of 40, 80, 200, 400, 600, 1000, and 1400 L/min/m<sup>2</sup>, respectively.

### Scour test<sup>a</sup>:

During the scour test, the Stormceptor® EF and Stormceptor® EFO OGS devices, with 10.2 cm (4 inches) of test sediment pre-loaded onto a false floor reaching 50% of the manufacturer's recommended maximum sediment storage depth, generate corrected effluent concentrations of 4.6, 0.7, 0, 0.2, and 0.4 mg/L at 5-minute duration surface loading rates of 200, 800, 1400, 2000, and 2600 L/min/m<sup>2</sup>, respectively.

### Light liquid re-entrainment test<sup>a</sup>:

During the light liquid re-entrainment test, the Stormceptor® EFO OGS device with surrogate low-density polyethylene beads preloaded within the lower chamber oil collection zone, representing a floating light liquid volume equal to a depth of 50.8 mm over the sedimentation area, retained 100, 99.5, 99.8, 99.8, and 99.9 percent of loaded beads by mass during the 5-minute duration surface loading rates of 200, 800, 1400, 2000, and 2600 L/min/m<sup>2</sup>.

---

<sup>a</sup> The claim can be applied to other units smaller or larger than the tested unit as long as the untested units meet the scaling rule specified in the Procedure for Laboratory of Testing of Oil Grit Separators (Version 3.0, June 2014)

## Performance results

The test sediment consisted of ground silica (1 – 1000 micron) with a specific gravity of 2.65, uniformly mixed to meet the particle size distribution specified in the testing procedure. The *Procedure for Laboratory Testing of Oil Grit Separators* requires that the three sample average of the test sediment particle size distribution (PSD) meet the specified PSD percent less than values within a boundary threshold of 6%. The comparison of the average test sediment PSD to the CETV specified PSD in Figure 2 indicates that the test sediment used for the capture and scour tests met this condition.

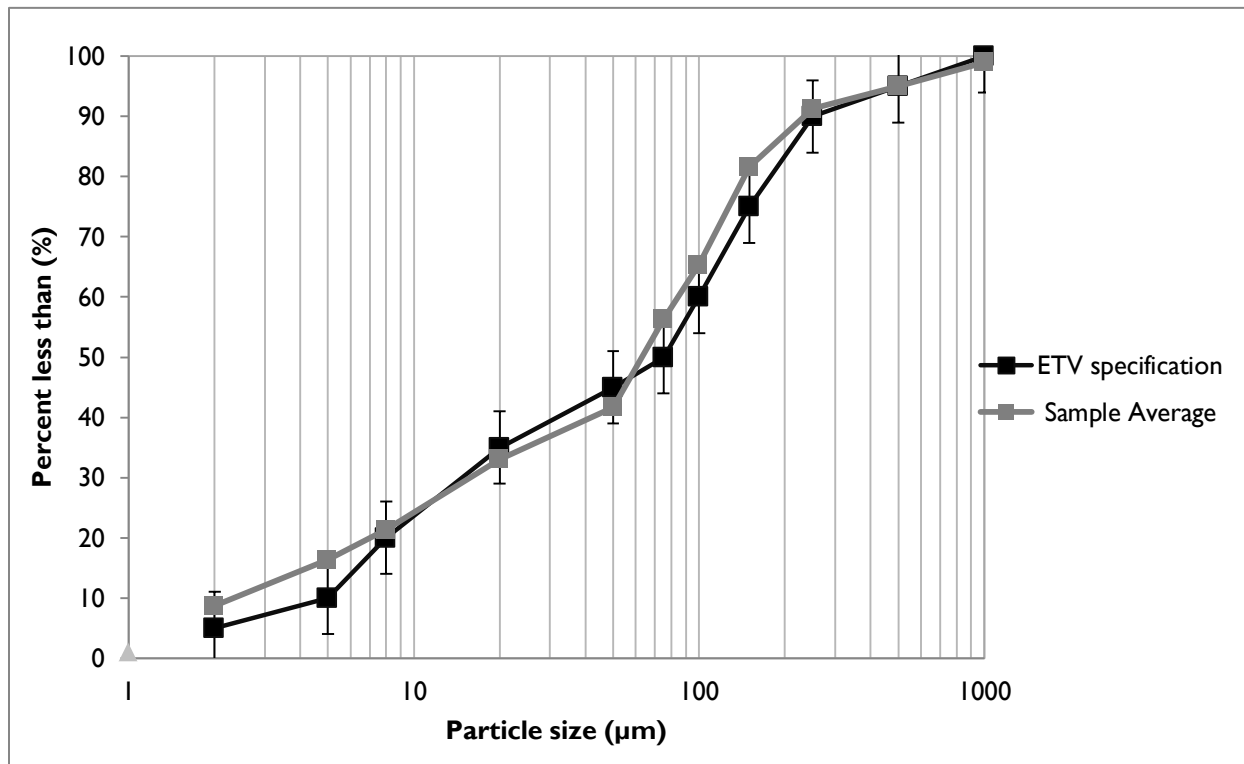

Figure 2. The three sample average particle size distribution (PSD) of the test sediment used for the capture and scour test compared to the specified PSD.

The capacity of the device to retain sediment was determined at seven surface loading rates using the modified mass balance method. This method involved measuring the mass and particle size distribution of the injected and retained sediment for each test run. Performance was evaluated with a false floor simulating the technology filled to 50% of the manufacturer's recommended maximum sediment storage depth. The test was carried out with clean water that maintained a sediment concentration below 20 mg/L. Based on these conditions, removal efficiencies for individual particle size classes and for the test sediment as a whole were determined for each of the tested surface loading rates (Table 1). Since the EF and EFO models are identical except for the weir height, which bypasses flows from the EFO model at a surface loading rate of 535 L/min/m<sup>2</sup> (13.1 gpm/ft<sup>2</sup>), sediment capture tests at surface loading rates from 40 to 400 L/min/m<sup>2</sup> were only performed on the EF unit. Surface loading rates of 600, 1000, and 1400 L/min/m<sup>2</sup> were tested on both units separately. Results for the EFO model at these higher flow rates are presented in Table 2.

In some instances, the removal efficiencies were above 100% for certain particle size fractions. These discrepancies are not unique to any one test laboratory and may be attributed to errors relating to the blending of sediment, collection of representative samples for laboratory submission, and laboratory



analysis of PSD. Due to these errors, caution should be exercised in applying the removal efficiencies by particle size fraction for the purposes of sizing the tested device (see [Bulletin # CETV 2016-11-0001](#)). The results for “all particle sizes by mass balance” (see Table 1 and 2) are based on measurements of the total injected and retained sediment mass, and are therefore not subject to blending, sampling or PSD analysis errors.

Table 1. Removal efficiencies (%) of the EF4 at specified surface loading rates

Particle size fraction (µm)	Surface loading rate (L/min/m <sup>2</sup> )						
	40	80	200	400	600	1000	1400
>500	90	58	58	100*	86	72	100*
250 - 500	100*	100*	100	100*	100*	100*	100*
150 - 250	90	82	26	100*	100*	67	90
105 - 150	100*	100*	100*	100*	100*	100*	100
75 - 105	100*	92	74	82	77	68	76
53 - 75	Undefined <sup>a</sup>	56	100*	72	69	50	80
20 - 53	54	100*	54	33	36	40	31
8 - 20	67	52	25	21	17	20	20
5 – 8	33	29	11	12	9	7	19
<5	13	0	0	0	0	0	4
<b>All particle sizes by mass balance</b>	<b>70.4</b>	<b>63.8</b>	<b>53.9</b>	<b>47.5</b>	<b>46.0</b>	<b>43.7</b>	<b>49.0</b>

<sup>a</sup> An outlier in the feed sample sieve data resulted in a negative removal efficiency for this size fraction.

\* Removal efficiencies were calculated to be above 100%. Calculated values ranged between 101 and 171% (average 128%). See text and [Bulletin # CETV 2016-11-0001](#) for more information.

Table 2. Removal efficiencies (%) of the EFO4 at surface loading rates above the bypass rate of 535 L/min/m<sup>2</sup>

Particle size fraction (µm)	Surface loading rate (L/min/m <sup>2</sup> )		
	600	1000	1400
>500	89	83	100*
250 - 500	90	100*	92
150 - 250	90	67	100*
105 - 150	85	92	77
75 - 105	80	71	65
53 - 75	60	31	36
20 - 53	33	43	23
8 - 20	17	23	15
5 – 8	10	3	3
<5	0	0	0
<b>All particle sizes by mass balance</b>	<b>41.7</b>	<b>39.7</b>	<b>34.2</b>

\* Removal efficiencies were calculated to be above 100%. Calculated values ranged between 103 and 111% (average 107%). See text and [Bulletin # CETV 2016-11-0001](#) for more information.

Figure 3 compares the particle size distribution (PSD) of the three sample average of the test sediment to the PSD of the sediment retained by the EF4 at each of the tested surface loading rates. Figure 4 shows the same graph for the EFO4 unit at surface loading rates above the bypass rate of 535 L/min/m<sup>2</sup>.

As expected, the capture efficiency for fine particles in both units was generally found to decrease as surface loading rates increased.

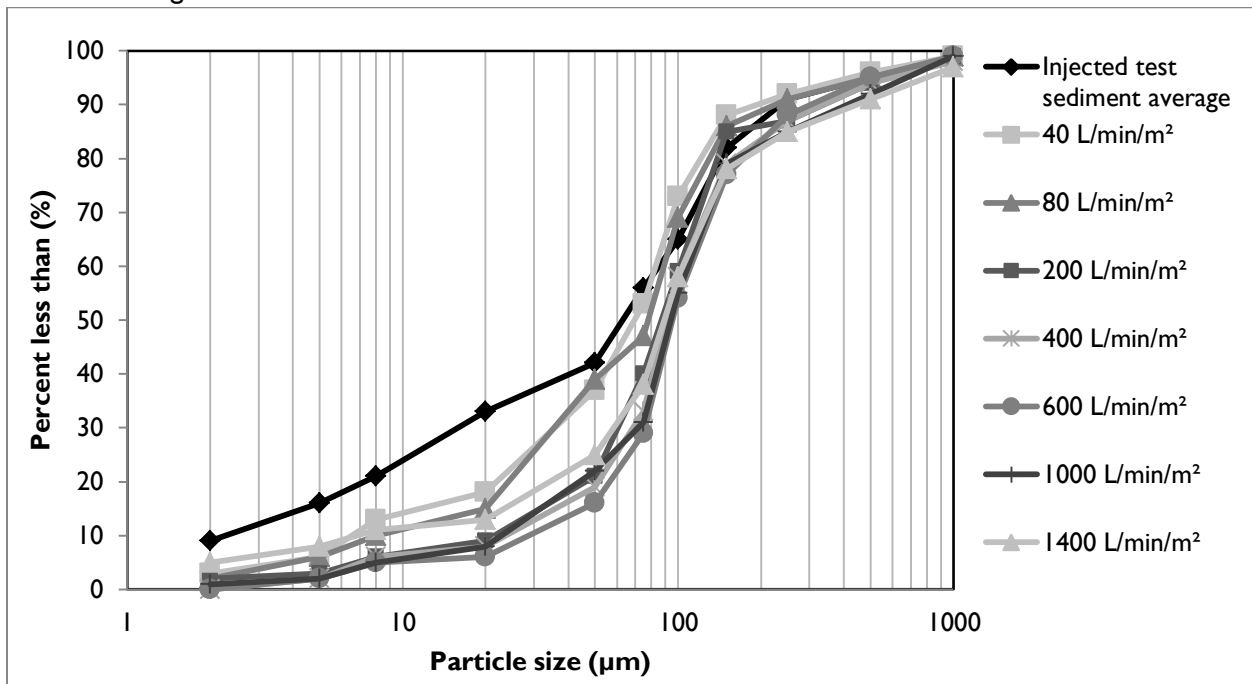

Figure 3. Particle size distribution of sediment retained in the EF4 in relation to the injected test sediment average.

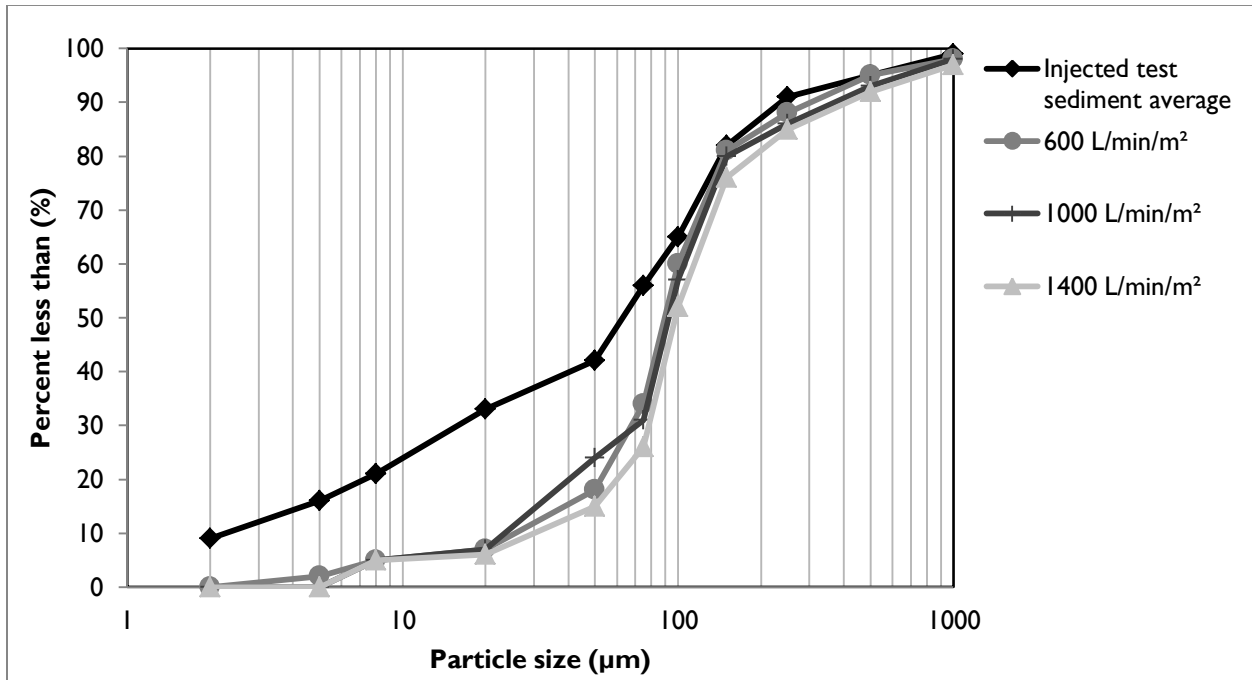

Figure 4. Particle size distribution of sediment retained in the EFO4 in relation to the injected test sediment average at surface loading rates above the bypass rate of 535 L/min/m<sup>2</sup>

Table 4 shows the results of the sediment scour and re-suspension test for the EF4 unit. The EFO4 was not tested as it was reasonably assumed that scour rates would be lower given that flow bypass occurs at a lower surface loading rate. The scour test involved preloading 10.2 cm of fresh test sediment into

the sedimentation sump of the device. The sediment was placed on a false floor to mimic a device filled to 50% of the maximum recommended sediment storage depth. Clean water was run through the device at five surface loading rates over a 30 minute period. Each flow rate was maintained for 5 minutes with a one minute transition time between flow rates. Effluent samples were collected at one minute sampling intervals and analyzed for Suspended Sediment Concentration (SSC) and PSD by recognized methods. The effluent samples were subsequently adjusted based on the background concentration of the influent water. Typically, the smallest 5% of particles captured during the 40 L/min/m<sup>2</sup> sediment capture test is also used to adjust the concentration, as per the method described in [Bulletin # CETV 2016-09-0001](#). However, since the composites of effluent concentrations were below the Reporting Detection Limit of the Laser Diffraction PSD methodology, this adjustment was not made. Results showed average adjusted effluent sediment concentrations below 5 mg/L at all tested surface loading rates.

It should be noted that the EF4 starts to internally bypass water at 1135 L/min/m<sup>2</sup>, potentially resulting in the dilution of effluent concentrations, which would not normally occur under typical field conditions because the field influent concentration would contain a much higher sediment concentration than during the lab test. Recalculation of effluent concentrations to account for dilution at surface loading rates above the bypass rate showed sediment effluent concentrations to be below 1.6 mg/L.

Table 4. Scour test adjusted effluent sediment concentration.

Run	Surface loading rate (L/min/m <sup>2</sup> )	Run time (min)	Background sample concentration (mg/L)	Adjusted effluent suspended sediment concentration (mg/L) <sup>a</sup>	Average (mg/L)
1	200	1:00	<RDL	11.9	4.6
		2:00		7.0	
		3:00		4.4	
		4:00		2.2	
		5:00		1.0	
		6:00		1.2	
2	800	7:00	<RDL	1.1	0.7
		8:00		0.9	
		9:00		0.6	
		10:00		1.4	
		11:00		0.1	
		12:00		0	
3	1400	13:00	<RDL	0	0
		14:00		0.1	
		15:00		0	
		16:00		0	
		17:00		0	
		18:00		0	
4	2000	19:00	1.2	0.2	0.2
		20:00		0	
		21:00		0	
		22:00		0.7	
		23:00		0	

		24:00		0.4	
5	2600	25:00	1.6	0.3	0.4
		26:00		0.4	
		27:00		0.7	
		28:00		0.4	
		29:00		0.2	
		30:00		0.4	

<sup>a</sup> The adjusted effluent suspended sediment concentration represents the actual measured effluent concentration minus the background concentration. For more information see [Bulletin # CETV 2016-09-0001](#).

The results of the light liquid re-entrainment test used to evaluate the unit’s capacity to prevent re-entrainment of light liquids are reported in Table 5. The test involved preloading 58.3 L (corresponding to a 5 cm depth over the collection sump area of 1.17m<sup>2</sup>) of surrogate low-density polyethylene beads within the oil collection skirt and running clean water through the device continuously at five surface loading rates (200, 800, 1400, 2000, and 2600 L/min/m<sup>2</sup>). Each flow rate was maintained for 5 minutes with approximately 1 minute transition time between flow rates. The effluent flow was screened to capture all re-entrained pellets throughout the test.

Table 5. Light liquid re-entrainment test results for the EFO4.

Surface Loading Rate (L/min/m <sup>2</sup> )	Time Stamp	Amount of Beads Re-entrained			
		Mass (g)	Volume (L) <sup>a</sup>	% of Pre-loaded Mass Re-entrained	% of Pre-loaded Mass Retained
200	62	0	0	0.00	100
800	247	168.45	0.3	0.52	99.48
1400	432	51.88	0.09	0.16	99.83
2000	617	55.54	0.1	0.17	99.84
2600	802	19.73	0.035	0.06	99.94
Total Re-entrained		295.60	0.525	0.91	--
Total Retained		32403	57.78	--	99.09
Total Loaded		32699	58.3	--	--

<sup>a</sup> Determined from bead bulk density of 0.56074 g/cm<sup>3</sup>

## Variations from testing Procedure

The following minor deviations from the *Procedure for Laboratory Testing of Oil-Grit Separators* (Version 3.0, June 2014) have been noted:

1. During the capture test, the 40 L/min/m<sup>2</sup> and 80 L/min/m<sup>2</sup> surface loading rates were evaluated over 3 and 2 days respectively due to the long duration needed to feed the required minimum of 11.3 kg of test sediment into the unit at these lower flow rates. Pumps were shut down at the end of each intermediate day, and turned on again the following morning. The target flow rate was re-established within 30 seconds of switching on the pump. This procedure may have allowed sediments to be captured that otherwise may have exited the unit if the test was

continuous. On the basis of practical considerations, this variance was approved by the verifier prior to testing.

2. During the scour test, the coefficient of variation (COV) for the lowest flow rate tested (200 L/min/m<sup>2</sup>) was 0.07, which exceeded the specified limit of 0.04 target specified in the OGS Procedure. A pump capable of attaining the highest flow rate of 3036 L/min had difficulty maintaining the lowest flow of 234 L/min but still remained within +/- 10% of the target flow and is viewed as having very little impact on the observed results. Similarly, for the light liquid re-entrainment test the COV for the flow rate of the 200 L/min/m<sup>2</sup> run was 0.049, exceeding the limit of 0.04, but is believed to introduce negligible bias.
3. Due to pressure build up in the filters, the runs at 1000 L/min/m<sup>2</sup> for the Stormceptor® EF4 and 1000 and 1400 L/min/m<sup>2</sup> for the Stormceptor® EFO4 were slightly shorter than the target. The run times were 54, 59 and 43 minutes respectively, versus targets of 60 and 50 minutes. The final feed samples were timed to coincide with the end of the run. Since >25 lbs of sediment was fed, the shortened time did not invalidate the runs.

## Verification

The verification was completed by the Verification Expert, Toronto and Region Conservation Authority, contracted by GLOBE Performance Solutions, using the International Standard **ISO 14034:2016 Environmental management – Environmental technology verification (ETV)**. Data and information provided by Imbrium Systems Inc. to support the performance claim included the following: Performance test report prepared by Good Harbour Laboratories, and dated September 8, 2017; the report is based on testing completed in accordance with the Procedure for Laboratory Testing of Oil-Grit Separators (Version 3.0, June 2014).

## What is ISO 14034:2016 Environmental management – Environmental technology verification (ETV)?

ISO 14034:2016 specifies principles, procedures and requirements for environmental technology verification (ETV), and was developed and published by the *International Organization for Standardization (ISO)*. The objective of ETV is to provide credible, reliable and independent verification of the performance of environmental technologies. An environmental technology is a technology that either results in an environmental added value or measures parameters that indicate an environmental impact. Such technologies have an increasingly important role in addressing environmental challenges and achieving sustainable development.

### For more information on the Stormceptor® EF4 and EFO4 please contact:

Imbrium Systems, Inc.  
407 Fairview Drive  
Whitby, ON  
L1N 3A9, Canada  
Tel: 416-960-9900  
info@imbriumsystems.com

### For more information on ISO 14034:2016 / ETV please contact:

GLOBE Performance Solutions  
World Trade Centre  
404 – 999 Canada Place  
Vancouver, BC  
V6C 3E2 Canada  
Tel: 604-695-5018 / Toll Free: 1-855-695-5018  
etv@globeperformance.com

### Limitation of verification

GLOBE Performance Solutions and the Verification Expert provide the verification services solely on the basis of the information supplied by the applicant or vendor and assume no liability thereafter. The responsibility for the information supplied remains solely with the applicant or vendor and the liability for the purchase, installation, and operation (whether consequential or otherwise) is not transferred to any other party as a result of the verification.