

# SITE SERVICING REPORT 21 HUNTMAR DRIVE

---

Project: 127134-6.04.01

City No.: D07-12-21-0035



Prepared for North American Development Group  
by IBI Group  
July 5, 2021

|          |   |           |
|----------|---|-----------|
| <b>1</b> | <b>INTRODUCTION.....</b>                      | <b>1</b>  |
| 1.1      | Scope .....                                   | 1         |
| 1.2      | Subject Site .....                            | 1         |
| 1.3      | Pre-consultation .....                        | 1         |
| <b>2</b> | <b>WATER DISTRIBUTION .....</b>               | <b>2</b>  |
| 2.1      | Existing Conditions .....                     | 2         |
| 2.2      | Design Criteria.....                          | 2         |
| 2.2.1    | Water Demands.....                            | 2         |
| 2.2.2    | System Pressure .....                         | 2         |
| 2.2.3    | Fire Flow Rates.....                          | 2         |
| 2.2.4    | Boundary Conditions .....                     | 3         |
| 2.3      | Proposed Water Plan .....                     | 3         |
| <b>3</b> | <b>WASTEWATER.....</b>                        | <b>4</b>  |
| 3.1      | Existing Conditions .....                     | 4         |
| 3.2      | Design Criteria.....                          | 4         |
| 3.3      | Recommended Wastewater Plan .....             | 4         |
| <b>4</b> | <b>STORMWATER SYSTEM .....</b>                | <b>5</b>  |
| 4.1      | Existing Conditions .....                     | 5         |
| 4.2      | Design Criteria.....                          | 5         |
| 4.3      | Proposed Minor System .....                   | 5         |
| 4.4      | Stormwater Management .....                   | 6         |
| 4.5      | Inlet Controls .....                          | 6         |
| 4.6      | On-Site Detention .....                       | 7         |
| 4.6.1    | Site Inlet Control .....                      | 7         |
| 4.6.2    | Overall Release Rate.....                     | 7         |
| <b>5</b> | <b>SEDIMENT AND EROSION CONTROL PLAN.....</b> | <b>8</b>  |
| <b>6</b> | <b>SOILS .....</b>                            | <b>8</b>  |
| <b>7</b> | <b>CONCLUSIONS.....</b>                       | <b>10</b> |

# 1 INTRODUCTION

## 1.1 Scope

The purpose of this report is to outline the required municipal services, including water supply, stormwater management and wastewater disposal, needed to support the redevelopment of the subject property. The property is approximately 1.6 hectares in area and is located on the west of Huntmar Drive just south of the intersection of Huntmar Drive and Hazeldean Road. The parcel is located across the road from the owners commercial development, and prior to the creation of Huntmar Drive the subject parcel was part of the main parcel located now located on the east side of Huntmar Dr.. Please refer to **Figure 1 – Location Plan** in **Appendix A** for more details.

This Site Servicing Study, which also includes the Stormwater Management Plan, and Erosion and Sedimentation Control Plans, are being completed in support of the Site Plan Application.

## 1.2 Subject Site

The subject lands are located within the Kanata West Development Area (KWDA) and therefore are subject to the requirements of the KWDA Master Servicing Reports. Since the first site plan approval in 2010, this parcel was intended to be developed as a commercial site, to address market demands the owner is submitting for Site Plan Approval for two six storey residential buildings, with a total of 344 residential units. The proposed development also includes two level of underground parking. Vehicular access to the site will be from Huntmar Drive, where the proposed driveway is opposite the existing entrance for the existing commercial site. Please refer to Site Plan prepared by RLA Architects located in **Appendix A** for more information.

The site currently consists of vacant lot, a copy of the site topographic survey and legal boundary plan prepared by Fairhall Moffatt and Woodland is included in **Appendix A**

## 1.3 Pre-consultation

It should be noted that a pre-consultation with the Ministry of the Environment is not required since this site is serviced by existing separated municipal sanitary and storm sewers and is a single owner residential site, thus an ECA is not required. A preconsultation meeting with the City of Ottawa was held on July 31, 2020 and a copy of the meeting notes are included in **Appendix A**.

## 2 WATER DISTRIBUTION

### 2.1 Existing Conditions

As previously noted, the site is located west of Huntmar Drive just north of Hazeldean Road. An existing 400 mm diameter watermain is located within the Huntmar Drive right of way. The watermain falls within the City of Ottawa's pressure zone 3W which will provide the water supply to the site. When the CDP and MSS were first completed to support the Kanata West development area, the planning for this area envisioned the adjacent parcels to the west to be serviced through this site. As development projects have advanced those parcels have been constructed or designed to be serviced independently from this site.

### 2.2 Design Criteria

#### 2.2.1 Water Demands

The population for apartment buildings is assumed at 1.4, 2.1 and 2.8 persons per unit for one, two and three bedroom units respectively, as found in Table 4.1 of the Design Guidelines. A watermain demand calculation sheet is included in **Appendix B** and the total water demands are summarized as follows:

|             | <u>Subject Site</u> |
|-------------|---------------------|
| Average Day | 2.00 l/s            |
| Maximum Day | 5.01 l/s            |
| Peak Hour   | 11.02 l/s           |

#### 2.2.2 System Pressure

The Ottawa Design Guidelines – Water Distribution (WDG001), July 2010, City of Ottawa, Clause 4.2.2 states that the preferred practice for design of a new distribution system is to have normal operating pressures range between 345 kPa (50 psi) and 480 kPa (80 psi) under maximum daily flow conditions. Other pressure criteria identified in Clause 4.2.2 of the guidelines are as follows:

|                  |   |
|------------------|---|
| Minimum Pressure | Minimum system pressure under peak hour demand conditions shall not be less than 276 kPa (40 psi)   |
| Fire Flow        | During the period of maximum day demand, the system pressure shall not be less than 140 kPa (20 psi) during a fire flow event.  |
| Maximum Pressure | In accordance with the Ontario Building/Plumbing Code, the maximum pressure should not exceed 552 kPa (80 psi). Pressure reduction controls will be required for buildings where it is not possible/feasible to maintain the system pressure below 552 kPa. |

#### 2.2.3 Fire Flow Rates

A calculation using the Fire Underwriting Survey (FUS) method was conducted to determine the fire flow requirement for both buildings on the site. The buildings are considered non-combustible construction. Results of the analysis provides a maximum fire flow rate of 11,000 l/min or 183 l/s is required. A copy of the FUS calculation is included in **Appendix B**. The buildings will be designed with a Siamese fire connection for each building and they will be located on the building's frontage on Huntmar Drive.



## 2.2.4 Boundary Conditions

A boundary condition was provided by the City of Ottawa for the development on the 400mm diameter watermain on Huntmar Drive. A copy of the boundary conditions is included in **Appendix B** and summarized in the following table. Since the proposed buildings are adjacent to the supply main and are connected with twin 200mm services no significant headloss is anticipated between the building and the source main which would impact the below noted analysis.

| BOUNDARY CONDITIONS     |               |
|-------------------------|---------------|
| SCENARIO                | HGL (m)       |
|                         | Huntmar Drive |
| Maximum HGL             | 161.1m        |
| Minimum HGL (Peak Hour) | 156.7m        |
| Max Day + Fire Flow     | 155.9m        |

## 2.3 Proposed Water Plan

The minimum water pressure inside the building at the connection is determined by the difference between the water entry elevation of 100.6m and the minimum HGL condition, resulting in a pressure 550 kPa which exceeds the minimum requirement of 276 kPa per the guidelines. Because the pressure at the 6<sup>th</sup> floor under minimum HGL conditions is close to the minimum requirement of 276 kPa, an onsite test will be required to confirm if a domestic water pump will be necessary for this building.

Maximum water pressure is determined by the difference between the water entry elevation of 100.6 m and the maximum HGL condition resulting in a pressure of 593.1 kPa, which is greater than the 552 kPa threshold in the guideline in which pressure control is required. Based on this result, pressure control is required for this building.

The boundary condition for Maximum Day and Fire Flow results in a pressure of 513.44 kPa at the ground floor level. In the guidelines, a minimum residual pressure of 140 kPa must be maintained in the distribution system for a fire flow and maximum day event. As a pressure of 513 kPa is achieved, the fire flow requirement is exceeded.

To service the property twin 200mm dia water services off Huntmar Drive are proposed, see site servicing plan 127134-C-001 in **Appendix B**. The proposed twin 200mm dia services will provide adequate supply to the building to meet demands while also providing service redundancy for the buildings.

## 3 WASTEWATER

### 3.1 Existing Conditions

When the MSS for the area was developed a 750mm dia trunk was designed to service this area, and as previously noted the usage was assumed to be commercial and based on the criteria at the time (50,000 l/d/Ha) this site was to drain into the 750 sewer. The site was also to convey flow from upstream lands to the west, however as previously noted the adjacent lands have been serviced independently.

### 3.2 Design Criteria

The sanitary sewers for the subject site will be based on the City of Ottawa design criteria. It should be noted that the sanitary sewer design for this study incorporates the latest City of Ottawa design parameters identified in Technical Bulletin ISTB-2018-01. Some of the key criteria will include the following:

- Commercial/Institutional flow 28,000 l/ha/d
- Residential flow 280 l/c/d
- Peaking factor 1.5 if ICI in contributing area >20%  
1.0 if ICI in contributing area <20%
- Infiltration allowance 0.33 l/s/ha
- Velocities 0.60 m/s min. to 3.0 m/s max.
- 

Given the above criteria, the average wastewater flow from the proposed development will 2.51 l/s, the detailed sanitary sewer calculations and Tributary area plan are included in **Appendix C**. As noted previously when the supporting sewers were designed the site was assumed to be developed as a commercial site with an average flow of 50,000 l/d/Ha, and an infiltration factor of 0.28l/s/Ha, which would have resulted in an average flow of 1.33 l/s. The current plan estimates an average flow of 2.51 l/s which is approximately 1.18 l/s greater then original design, which within the larger context of discharging into a 750mm truck with a capacity of over 500l/s it is not anticipated to yield any negative impact on the down stream system.

### 3.3 Recommended Wastewater Plan

A 250mm dia sanitary service lateral is proposed to be extended from the existing sanitary MH in Huntmar Drive to service this site. Please refer to the site servicing plan 127134-C-001 in **Appendix A** for details.

## 4 STORMWATER SYSTEM

### 4.1 Existing Conditions

When the Kanata West MSS was completed this site was limited to a minor system flow (5yr) to 85 l/s/Ha and major flow was to be directed to Huntmar Drive. As noted previously the CDP envisioned a connection through this site to the adjacent sites to the west, however those parcels have advanced their design/construction and are now independent of servicing through this site for both minor and major flows.

### 4.2 Design Criteria

Since this site is serviced by a storm sewer system that was designed based on 85 l/s/Ha City of Ottawa requires the site to follow the following design criteria;

- Storm sewers designed to a 2 year level of service
- Site to be designed to limit the 100 year post development flow to a maximum of 132.74l/s (1.562 Ha @ 85 l/s/Ha).

The stormwater system was designed following the principles of dual drainage, making accommodations for both major and minor flow.

Some of the key criteria include the following:

- Design Storm 1:2 year return (Ottawa)
- Rational Method Sewer Sizing
- Initial Time of Concentration 10 minutes
- Runoff Coefficients
  - Landscaped Areas C = 0.30
  - Asphalt/Concrete C = 0.90
  - Roof C = 0.90
- Pipe Velocities 0.80 m/s to 6.0 m/s
- Minimum Pipe Size 250 mm diameter  
(200 mm CB Leads)

### 4.3 Proposed Minor System

Using the above-noted criteria, the proposed on-site storm sewers were sized accordingly. A detailed storm sewer design sheet and the associated storm sewer drainage area plan are included in **Appendix D**. The current servicing drawing outlines the proposed underground parking structure, all of the deck drains are located above the underground parking structure will be routed inside the building via the mechanical plumbing systems and directed to the building cistern located adjacent to the northern wall. All roof deck inlets will be controlled and will utilize rooftop storage, restricted flow from the roof decks will bypass the cistern and discharge to the

storm service. The runoff from the landscaped areas will be collected and conveyed through a series of clear stone infiltration cells. These cells will provide both infiltration and stormwater storage. Volume of storage below the invert of the perforated pipe will be used for infiltration, and the volume of storage above the invert of the perforated pipe will be used for stormwater storage. Flow from the system will be controlled with an ICD and the outlet will connect to the joint outlet servicing the roof drains, and onsite cistern.

#### 4.4 Stormwater Management

The subject site will be limited to a release rate established using the criteria described in section 4.2. This will be achieved through an inlet control device (ICD) at the outlet of the cistern, and inlet control devices on all roof deck inlets, and ICD at the outlet of the infiltration cells.

When rainfall events generate flows that are in excess of the site's allowable release rate excess volume will be stored within the combination of a cistern, roof top and infiltration cells.

At certain locations within the site, the opportunity to capture runoff is limited due to grading constraints and building geometry. These locations are generally located at the perimeter of the site where it is necessary to tie into public boulevards and adjacent properties, and it is not always feasible to capture or store stormwater runoff. These "uncontrolled" areas, 0.126 hectares in total, based on 1:100 year storm uncontrolled flows the uncontrolled areas generate 53.24 l/s runoff (refer to Section 4.5 for calculation). The various roof decks will have inlets that control flow to a total of 27.72 l/s, which leaves 51.78l/s for the remaining surface inlets discharging into the cistern and infiltration cell, which have been sized to accommodate flow during the 1:100-year event, with no overflow leaving the site.

#### 4.5 Inlet Controls

The allowable release rate for the 1.562 Ha site as noted previously is 132.74 l/s.

As noted in Section 4.4, a portion of the site will be left to discharge to the surrounding boulevards and roadways uncontrolled.

Based on a 1:100 year event, the flow from the three uncontrolled areas can be determined as:

$$Q_{\text{uncontrolled}} = 2.78 \times C \times i_{100\text{yr}} \times A \quad \text{where:}$$

**C** = Average runoff coefficient of uncontrolled area

**i<sub>100yr</sub>** = Intensity of 100-year storm event (mm/hr)  
 =  $1735.688 \times (T_c + 6.014)^{0.820} = 178.56 \text{ mm/hr}$ ; where  $T_c = 10 \text{ minutes}$

**A<sub>1</sub>** = Uncontrolled Area = 0.037 Ha,  $C_{100} = 1.0$ ,  $Q_1 = 18.37 \text{ l/s}$

**A<sub>2</sub>** = Uncontrolled Area = 0.025 Ha,  $C_{100} = 0.25$ ,  $Q_2 = 3.10 \text{ l/s}$

**A<sub>3</sub>** = Uncontrolled Area = 0.064 Ha,  $C_{100} = 1.00$ ,  $Q_3 = 31.77 \text{ l/s}$

Therefore, the uncontrolled release rate can be determined as:

$$Q_{\text{uncontrolled}} = 18.37 + 3.10 + 31.77 = 53.24 \text{ L/s}$$

The maximum allowable release rate from the remainder of the site can then be determined as:

$$Q_{\text{max allowable}} = Q_{\text{restricted}} - Q_{\text{uncontrolled}}$$

$$= 132.74 \text{ L/s} - 53.24 \text{ L/s} = 79.50 \text{ L/s}$$

## 4.6 On-Site Detention

As noted in section 4.4 any excess storm water up to the 100-year event is to be stored on-site within the building cistern, infiltration cells, and on the roof decks in order to not surcharge the downstream municipal storm sewer system.

### 4.6.1 Site Inlet Control

The roof decks will utilize restrictor inlets such as the Watts RD-100-A-ADJ (or approved equal) to limit the inflow from each section of roof to the identified flow rates. Storage of runoff on the roof decks will be required to accommodate the 1:100 yr event, and scuppers will provide for overflow should a more extreme event occur or should an inlet become blocked. The Modified Rational Method (MRM) was used to identify the required storage, see the MRM calculations in **Appendix D** for details. The deck and driveway areas drain to the storm water cistern located adjacent to the building north wall, where a Tempest HF ICD (or approved equal) will restrict the flow from the tank to 41.05l/s at 1.25m head. The landscape areas will drain to the infiltration cells where additional storage above the infiltration volume will be used to accommodate restricting the flow from this system to 11.26 l/s with a Tempest MHF ICD at 0.71m head, the MRM spreadsheet in **Appendix D** identifies the required storage to accommodate the 1:100yr event. The following table summarizes the on-site storage requirements during both the 1:2-year and 1:100-year events.

| ICD AREA     | TRIBUTARY AREA | AVAILABLE STORAGE (M <sup>3</sup> ) | 100-YEAR STORM        |                                    | 2-YEAR STORM          |                                    |
|--------------|----------------|-------------------------------------|-----------------------|------------------------------------|-----------------------|------------------------------------|
|              |                |                                     | RESTRICTED FLOW (L/S) | REQUIRED STORAGE (M <sup>3</sup> ) | RESTRICTED FLOW (L/S) | REQUIRED STORAGE (M <sup>3</sup> ) |
| Cistern      | 0.507          | 211.0                               | 40.52                 | 210.68                             | 40.52                 | 55.55                              |
| Roof Deck 1A | 0.044          | 17.6                                | 2.52                  | 16.02                              | 2.52                  | 3.88                               |
| Roof Deck 1B | 0.041          | 16.4                                | 2.52                  | 14.5                               | 2.52                  | 3.43                               |
| Roof Deck 1C | 0.029          | 11.6                                | 1.89                  | 10.01                              | 1.89                  | 2.33                               |
| Roof Deck 1D | 0.057          | 23.09                               | 2.52                  | 22.86                              | 2.52                  | 5.89                               |
| Roof Deck 1E | 0.063          | 25.2                                | 3.15                  | 24.15                              | 3.15                  | 6.06                               |
| Roof Deck 2A | 0.044          | 17.6                                | 2.52                  | 16.01                              | 2.52                  | 3.87                               |
| Roof Deck 2B | 0.077          | 32.73                               | 3.15                  | 31.73                              | 3.15                  | 8.33                               |
| Roof Deck 2C | 0.029          | 11.6                                | 1.89                  | 10.01                              | 1.89                  | 2.33                               |
| Roof Deck 2D | 0.057          | 23.09                               | 2.52                  | 22.86                              | 2.52                  | 5.89                               |
| Roof Deck 2E | 0.029          | 11.6                                | 1.89                  | 10.01                              | 1.89                  | 2.33                               |
| Roof Deck 2F | 0.059          | 23.6                                | 3.15                  | 22.07                              | 3.15                  | 5.44                               |
| Landscape    | 0.396          | 64.9                                | 11.26                 | 64.89                              | 11.26                 | 15.44                              |
| Unrestricted | 0.126          |                                     | 53.24                 |                                    | 24.60                 |                                    |
| <b>TOTAL</b> | <b>1.555</b>   | <b>490.01</b>                       | <b>132.74</b>         | <b>475.80</b>                      | <b>104.10</b>         | <b>120.77</b>                      |

In all instances the required storage is met with the building cistern, landscape and roof top storage, respectively.

### 4.6.2 Overall Release Rate

As demonstrated above, the site uses various inlet control devices to restrict the 100 year storm event to 132.74 l/s. Restricted stormwater will be contained onsite by the building cistern,

landscape clear stone cells, and roof top storage. Up to and including the 100 year event, there will be no overflow off-site from restricted areas, if however an more intense storm or should an inlet become blocked, overland routing has been provided to the approved outlet per the original system design.

## 5 SEDIMENT AND EROSION CONTROL PLAN

During construction, existing stream and storm water conveyance systems can be exposed to significant sediment loadings. A number of construction techniques designed to reduce unnecessary construction sediment loadings may be used such as;

- Filter socks will remain on open surface structures such as manholes and catchbasins until these structures are commissioned and put into use;
- Installation of silt fence, where applicable, around the perimeter of the proposed work area.

During construction of the services, any trench dewatering using pumps will be fitted with a “filter sock.” Thus, any pumped groundwater will be filtered prior to release to the existing surface runoff. The contractor will inspect and maintain the filter sock as needed including sediment removal and disposal.

All catchbasins, and to a lesser degree manholes, convey surface water to sewers. Consequently, until the surrounding surface has been completed these structures will be protected with a sediment capture filter sock to prevent sediment from entering the minor storm sewer system. These will stay in place and be maintained during construction and build-out until it is appropriate to remove them.

The Sediment and Erosion Control Plan 127134-C-900 is included in **Appendix E**.

## 6 SOILS

Paterson Group was retained to prepare a geotechnical investigation for the proposed development. The objectives of the investigation were to prepare a report to:

- Determine the subsoil and groundwater conditions at the site by means of boreholes and monitoring well program.
- To provide geotechnical recommendations pertaining to design of the proposed development including construction considerations.

The geotechnical report PG5006-1 rev 2, “Geotechnical Investigation 21 Huntmar Drive” dated December 1, 2020. A copy of the report has been included with the SPA application. The report contains recommendations for building construction and site services, which include but are not limited to the following for site servicing:

- Bedding and cover for service pipes: bedding min 150mm compacted (95% SPMDD) OPSS Gran. A to the springline, and covered with OPSS Gran A
- Fill for driveway to be suitable native material or OPSS Select Subgrade Material placed in thin lifts compacted to 95% SPMDD
- Long term groundwater level 3 to 4m below grade
- Permissible Grade raise 1.2m

| MATERIAL  | Layer Thickness  |
|---|--|
| <ul style="list-style-type: none"> <li><b>Car Only Parking Areas</b></li> </ul>                               |  |
| <ul style="list-style-type: none"> <li>Asphalt Wearing Course (Superpave 12.5)</li> </ul>                     | <ul style="list-style-type: none"> <li>• 50 mm</li> </ul>  |
| <ul style="list-style-type: none"> <li>Well Graded Granular Base Course (Granular 'A')</li> </ul>             | <ul style="list-style-type: none"> <li>• 150 mm</li> </ul> |
| <ul style="list-style-type: none"> <li>Well Graded Granular Sub-Base Course (Granular 'B' Type II)</li> </ul> | <ul style="list-style-type: none"> <li>• 300 mm</li> </ul> |
| <ul style="list-style-type: none"> <li><b>Access Lanes and Heavy Truck Parking</b></li> </ul>                 |  |
| <ul style="list-style-type: none"> <li>Asphalt Wearing Course (Superpave 12.5)</li> </ul>                     | <ul style="list-style-type: none"> <li>• 40 mm</li> </ul>  |
| <ul style="list-style-type: none"> <li>Asphalt Binder Course (Superpave 19.0)</li> </ul>                      | <ul style="list-style-type: none"> <li>• 50 mm</li> </ul>  |
| <ul style="list-style-type: none"> <li>Well Graded Granular Base Course (Granular 'A')</li> </ul>             | <ul style="list-style-type: none"> <li>• 150 mm</li> </ul> |
| <ul style="list-style-type: none"> <li>Well Graded Granular Sub-Base Course (Granular 'B' Type II)</li> </ul> | <ul style="list-style-type: none"> <li>• 400 mm</li> </ul> |

Infiltration targets for the proposed site were outlined in the KWDA MSP. As indicated in Figure 5.4 of the MSS, the soil type within the proposed development area is characterized as clay with low recharge potential, and the geotechnical engineer confirmed the soil has a typical permeability of 7 to 25mm/hr . The infiltration target for the area, as identified within the MSP is 50-70mm/year. The subject site consists of approximately 1.56 Ha of development, the site is comprised of impervious Building deck and roof surfaces, and pervious landscape areas. It is proposed to install infiltration cell within the landscape areas to assist the pervious landscape area meet the infiltration target for the site.

For the previous phases of the original development an infiltration strategy for the site was developed in consultation with the MVCA; see approval email from MVCA (Doug Nuttall) in **Appendix E**. The strategy included three sources: natural infiltration from rainfall, infiltration from irrigation system, and infiltration from a dry well supplied by roof runoff. For this phase where more landscape area is available, we propose to only use infiltration cells supplied with rainfall runoff from the landscape areas.

The Infiltration cells will be drywells constructed approximately 1.5 to 1.8m below grade with clear stone, each cell will be 4m wide by 60m long, and 0.2m clear depth from bottom of perforated pipe to the bottom of the cell. Each cell has a volume of 48m<sup>3</sup>, clear stones have approximately 30% resulting in approximately 14.4m<sup>3</sup> of storage available for each cell for a total of 43.2m<sup>3</sup>. The geotechnical engineer has confirmed the long range water table is 3 to 4m below the surface and will not impact the cells.

Rainfall from the 3950 m<sup>2</sup> of landscape areas will supply the infiltration cells, the cells are set up such that if the volume of runoff from the landscape area exceeds the storage capacity of the dry well excess runoff is discharged to the storm sewer, see the Servicing Plan C-100 in **Appendix A**, and the Grading Plan C-200 in **Appendix E**.

Based on previously approved rainfall data where for the months of March up to and including November, 40 days of 5mm or more rain occurred, and for the same period 22 days of 10mm or more rain occurred, a review of 2020 data yielded 40 days 5mm or more, 19 days 10mm or more. Also for 2020 data there were no back to back rain days of 10mm or more. Since the cells have a relatively shallow storage depth (200mm) the anticipated time to infiltrate is between 8 to 28hrs (7 to 25mm/hr), which could accommodate historic back to back events. Assuming 80% of rainfall either infiltrates naturally or is collected by the drains and discharged into the drywell, the following volume of rainfall will supply the runoff to meet the infiltration targets:

5mm, at 80% = 4mm, for 3950 m<sup>2</sup> of landscape area = 15.8m<sup>3</sup>, for 40 events = 632m<sup>3</sup>

10mm, at 80%= 8mm (less 4mm from above) = 4mm for 3950 m<sup>2</sup> of landscape area = 15.8m<sup>3</sup>, for 19 events = 300.2m<sup>3</sup>. These events provide approximately of 932.2m<sup>3</sup> of rainfall runoff available for infiltration.

For the 1.56 Ha site this equates to approximately 59.7.8mm/yr of infiltration, which is within the guideline of 50 to 70 mm/yr.

## 7 CONCLUSIONS

Municipal water, wastewater and stormwater systems required to accommodate the proposed development are available to service the proposed development. Prior to construction, existing sewers are to be CCTV inspected to assess sewer condition.

This report has demonstrated sanitary and storm flows from and water supply to the subject site can be accommodated by the existing infrastructure. Also, the proposed servicing has been designed in accordance with MECP and City of Ottawa current level of service requirements.

The use of lot level controls, conveyance controls and end of pipe controls outlined in the report will result in effective treatment of surface stormwater runoff from the site. Adherence to the sediment and erosion control plan during construction will minimize harmful impacts on surface water.

Based on the information provided herein, the development can be serviced to meet City of Ottawa requirements.

Report prepared by:



Demetrius Yannouloupoulos, P. Eng.  
Director, Ottawa Office Lead

"J:\127134\_21 Huntmar rd\_6.0\_Technical\6.04\_Civil\01brief\1st Submission\CTR-site-servicing-erosion-2021-06-29.docx"



# **APPENDIX A**

- Site Plan
- Topographic Survey
- Preconsultation Meeting Notes



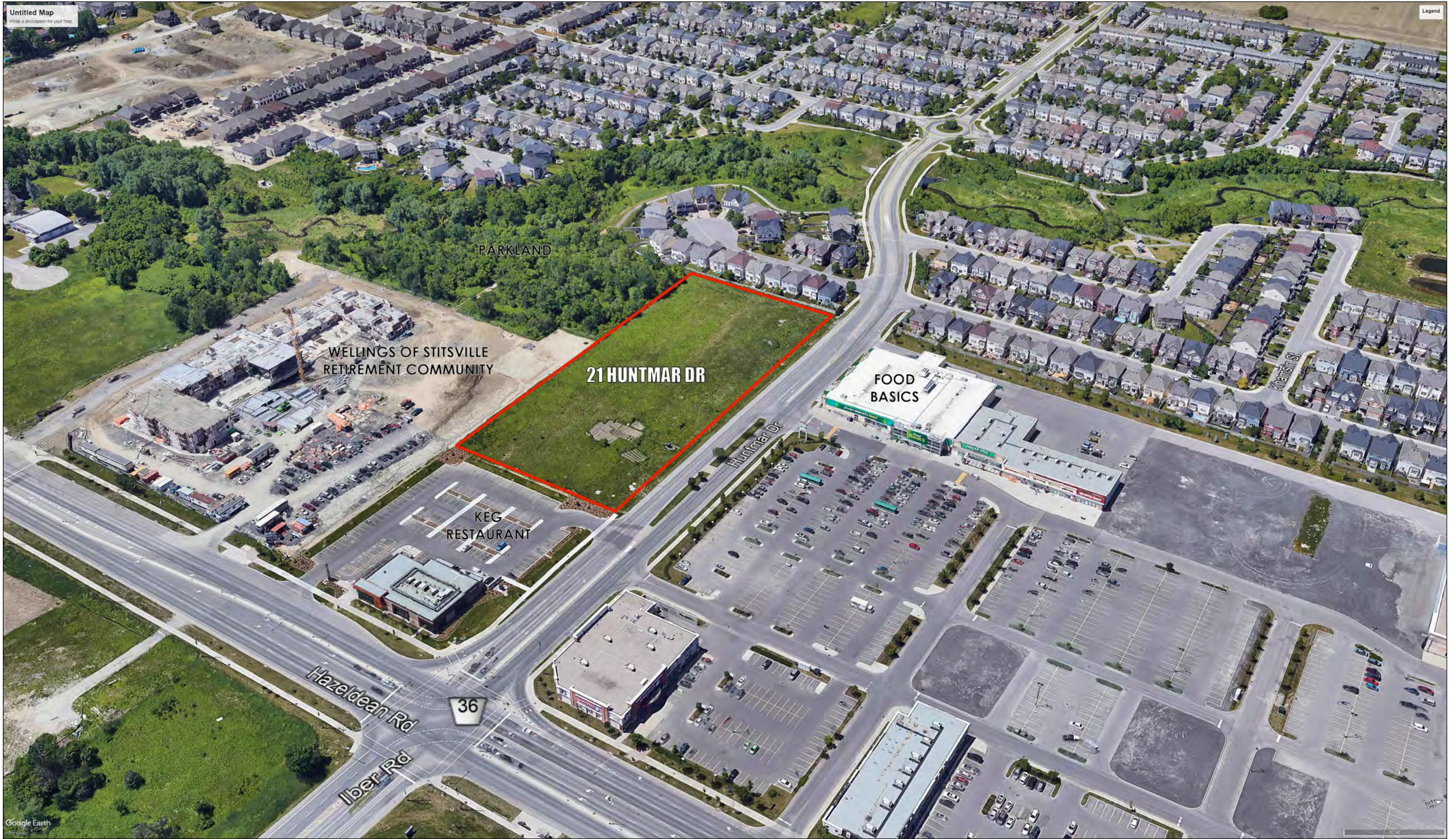

Untitled Map  
Write a description for your map.

Legend

PARKLAND

WELLINGS OF STITSVILLE  
RETIREMENT COMMUNITY

21 HUNTMAR DR

FOOD  
BASICS

KEG  
RESTAURANT

Hazeldean Rd

Iber Rd

36

Huntmar Dr

Kransi St

Google Earth

rla / architecture  
roderick lahey architect inc.

# SITE LOCATION

February 2020

# 21 HUNTMAR DRIVE

OTTAWA, ONTARIO

# 1A



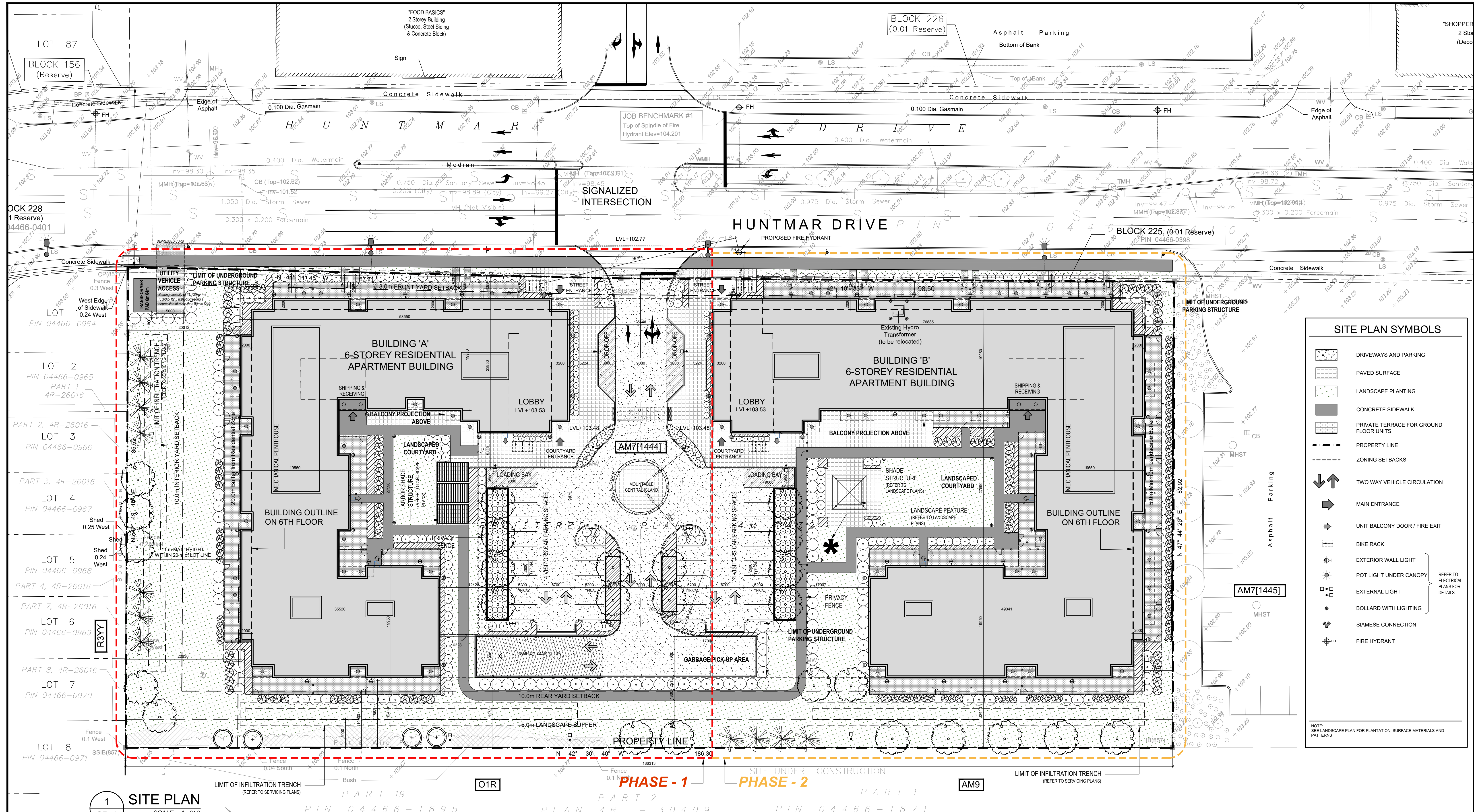

IT IS THE RESPONSIBILITY OF THE APPROPRIATE CONTRACTOR TO CHECK AND VERIFY ALL DIMENSIONS ON SITE AND TO REPORT ALL ERRORS AND/OR OMISSIONS TO THE ARCHITECT.

ALL CONTRACTORS MUST COMPLY WITH ALL PERTINENT CODES AND BY-LAWS. THIS DRAWING MAY NOT BE USED FOR CONSTRUCTION UNTIL SIGNED BY THE ARCHITECT. DO NOT SCALE DRAWINGS. COPYRIGHT RESERVED.

**NOTATION SYMBOLS:**

- INDICATES DRAWING NOTES, LISTED ON EACH SHEET.
- INDICATES ASSEMBLY TYPE; REFER TO TYPICAL ASSEMBLY SCHEDULE.
- INDICATES WINDOW TYPE; REFER TO WINDOW ELEVATIONS AND DETAILS ON A300 SERIES.
- INDICATES DOOR TYPE; REFER TO DOOR SCHEDULE AND DETAILS ON A300 SERIES.

**NOTES:**

- THE SITE WILL BE DEVELOPED IN TWO PHASES AS SHOWN.
- HUNTMAR DRIVE IS INTENDED TO BE USED AS THE FIRE ACCESS ROUTE. BUILDING ENTRANCES ARE LOCATED WITHIN A DISTANCE OF LESS THAN 15M FROM THE CURB OF HUNTMAR DRIVE.
- SNOW SHALL BE REMOVED FROM THE SITE.

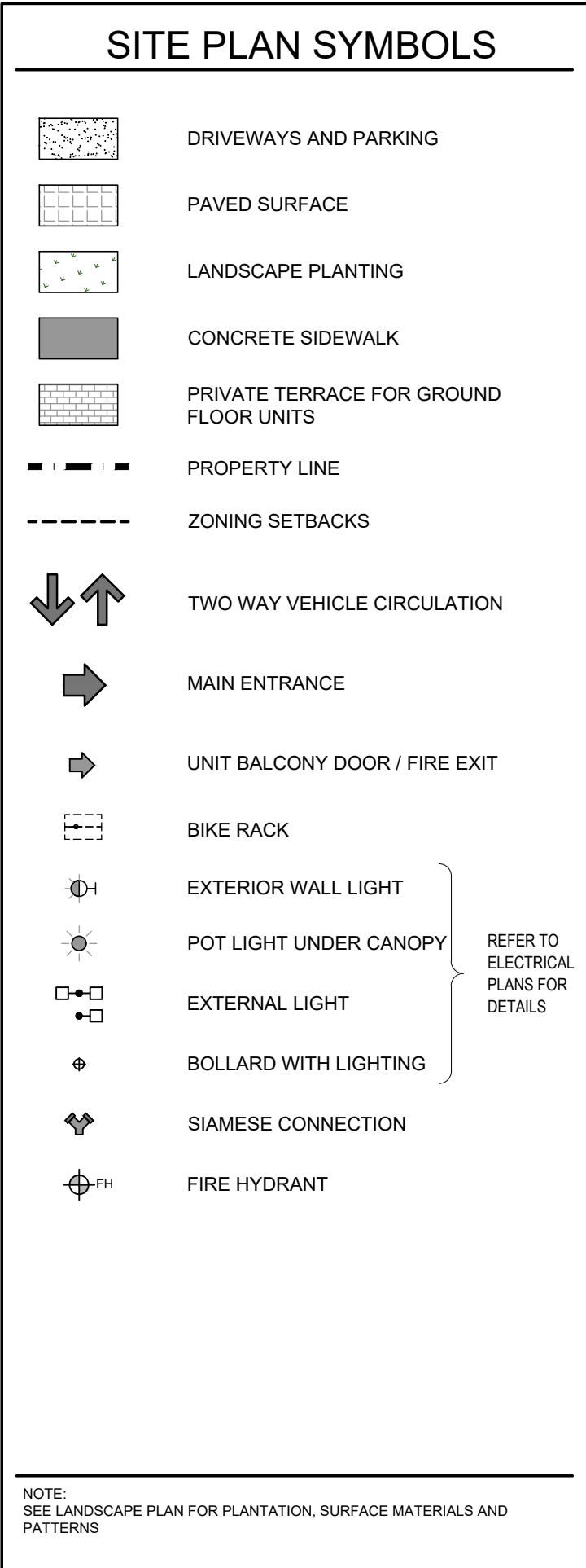

**1 SITE PLAN**  
SCALE = 1 : 250

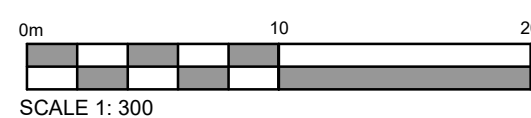

**KEY MAP**

|  |  |
|--|--|
| <b>PROJECT DEVELOPER</b><br><b>NORTH AMERICAN DEVELOPMENT GROUP</b><br>2851 John Street, Suite One<br>Markham, Ontario L3R 5R7<br>Tel: (905) 477-9200<br>E-Mail: vmccrum@nadg.com              | <b>CIVIL ENGINEER</b><br><b>IBI GROUP</b><br>400-333 Preston Street<br>Ottawa ON K1S 5N4 Canada<br>Tel: (613)225-1311<br>Email: dyanouloupolos@IBIgroup.com  |
| <b>SURVEYOR</b><br><b>FAIRHALL, MOFFATT &amp; WOODLAND LIMITED</b><br>100-600 TERRY FOX DRIVE<br>KANATA, ONTARIO K2L 4B6<br>Tel: (613) 591-2580 • Fax: (613) 591-1495<br>Email: info@fmw.on.ca | <b>LANDSCAPE DESIGNER</b><br><b>NAK Design Strategies</b><br>1285 Wellington St. W<br>Ottawa, ON K1Y 3A8<br>Tel: (613) 237-2345<br>E-Mail: ottawa@nak-design.com   |
| <b>GEOTECHNICAL ENGINEER</b><br><b>paterson group</b><br>154 Colonnade Road South<br>Ottawa, Ontario, K2E 7J5<br>Tel: 613.226-7381<br>Email: DGilbert@Patersongroup.ca                         | <b>TRANSPORTATION ENGINEER</b><br><b>D. J. Halpenny &amp; Associates Ltd.</b><br>Consulting Transportation Engineers,<br>P. O. Box 774, Manotick, ON K4M 1A7<br>Tel (613) 692-8662 • Fax (613) 692-1945<br>Email: david@djhalpenny.com |

**ZONING INFORMATION**

|  |                                      |
|--|--------------------------------------|
| ZONE   | AM7 (1444)                           |
| SITE AREA  | 15,616.6 sq. m.<br>(168,096 sq. ft.) |
| MAX. BUILDING HEIGHT   | 15.0m                                |
| MAX. BUILDING HEIGHT AS APPROVED THROUGH MINOR VARIANCE APPLICATION (FILE NO. D06-00-2016-00195) | 20.8m                                |
| FRONT YARD SETBACK   | 3.0m                                 |
| REAR YARD SETBACK  | 10.0m                                |
| REAR YARD SETBACK ABUTTING 'R' ZONE  | 10.0m                                |
| BUILDING FRONTAGE WITHIN 3.0m  | 30%                                  |
| LANDSCAPE BUFFER @ 'R' ZONE  | 10.0m                                |
| LANDSCAPE BUFFER @ REAR LOT LINE   | 5.0m                                 |
| MAXIMUM LOT COVERAGE   | 50%                                  |

**PROJECT STATISTICS**

|                    |        |
|--------------------|--------|
| BUILDING HEIGHT    | 20.8 M |
| FRONT YARD SETBACK | 3.0 M  |
| SIDE YARD SETBACK  | 20.0 M |
| REAR YARD SETBACK  | 12.4 M |

**BUILDING STATISTICS**

|   |                                     |
|---|-------------------------------------|
| TOTAL GROSS BUILDING AREA (Estimated Efficiency @85%) | 26,623.34 sq. m.<br>286,571 sq. ft. |
| TOTAL DWELLING UNITS                                  | 344 DU                              |

| PHASE - 1 BUILDING 'A'                          | PHASE - 2 BUILDING 'B'                                    |
|---|---|
| <b>BUILDING AREAS</b><br>(BUILDING FOOTPRINT)   | <b>BUILDING AREAS</b><br>(BUILDING FOOTPRINT)             |
| GROUND FLOOR                                    | 2,340.97 sq. m.<br>25,198 sq. ft.                         |
| 2nd to 5th FLOOR                                | 4 x 2,340.97 sq. m.<br>9,363.88 sq. m.<br>100,792 sq. ft. |
| 6th FLOOR                                       | 2,091.25 sq. m.<br>22,873 sq. ft.                         |
| TOTAL AREA                                      | 13,796.10 sq. m.<br>148,500 sq. ft.                       |
| GROSS BUILDING AREA (Estimated Efficiency @85%) | 11,726.68 sq. m.<br>126,225 sq. ft.                       |
| <b>UNIT STATISTICS</b>                          | <b>UNIT STATISTICS</b>                                    |
| 1 BEDROOM UNIT                                  | 21  |
| 1 BEDROOM + STUDY UNIT                          | 17  |
| 2 BEDROOM UNIT                                  | 75  |
| 2 BEDROOM + STUDY UNIT                          | 27  |
| TOTAL   | 140   |
| <b>CAR PARKING</b>                              | <b>BICYCLE PARKING</b>                                    |
| SURFACE PARKING                                 | 14  |
| PARKING LEVEL P1                                | 155   |
| PARKING LEVEL P2                                | 187   |
| TOTAL   | 356   |
| OUTDOOR STALLS                                  | 12  |
| LEVEL P1  | 70  |
| TOTAL   | 82  |

**CAR PARKING**

|                        |                            |     |
|------------------------|----------------------------|-----|
| <b>REQUIRED</b>        | @ 1.2 PER UNIT (344 UNITS) | 413 |
| RESIDENCE              | @ 0.2 PER UNIT             | 69  |
| TOTAL                  |                            | 482 |
| <b>PROVIDED</b>        |                            |     |
| SURFACE PARKING        |                            | 28  |
| PARKING LEVEL P1       |                            | 298 |
| PARKING LEVEL P2       |                            | 187 |
| TOTAL                  |                            | 513 |
| <b>BICYCLE PARKING</b> |                            |     |
| <b>REQUIRED</b>        | @ 0.5 PER UNIT (344 UNITS) | 172 |
| RESIDENCE              |                            |     |
| <b>PROVIDED</b>        |                            |     |
| TOTAL BICYCLE PARKING  |                            | 209 |

**AMENITY SPACE**

|                                |   |                |
|--------------------------------|---|----------------|
| <b>REQUIRED</b>                | REQUIRED - 6.0M <sup>2</sup> PER UNIT (344) = | 2,064 sq. m.   |
| RESIDENCE                      | REQUIRED COMMUNAL @ 50% =                     | 1,032 sq. m.   |
| <b>PROVIDED</b>                |   |                |
| EXTERIOR AT GRADE              |   | 2165.0 sq. m.  |
| GROUND FLOOR COMMUNAL INTERIOR |   | 947.0 sq. m.   |
| GROUND FLOOR PRIVATE TERRACES  |   | 924.0 sq. m.   |
| PRIVATE BALCONIES              |   | 1429.0 sq. m.  |
| 6th FLOOR PRIVATE DECKS        |   | 541.0 sq. m.   |
| ROOF FLOOR COMMUNAL TERRACE    |   | 480.0 sq. m.   |
| TOTAL                          |   | 6,486.0 sq. m. |
| TOTAL COMMUNAL                 |   | 3,592.0 sq. m. |

**SOLID WASTE COLLECTION:**

|  |                 |                 |
|--|-----------------|-----------------|
| <b>BUILDING 'A'</b>                        | <b>REQUIRED</b> | <b>PROVIDED</b> |
| GARBAGE @ 0.110 cu yd per unit             | 15.40 yd        | 16 yd           |
| GMP CONTAINERS @ 0.018 cu yd per unit      | 2.52 yd         | 3 yd            |
| FIBRE CONTAINERS @ 0.038 cu yd per unit    | 5.32 yd         | 6 yd            |
| ORGANICS CONTAINERS @ one 240L per 50 unit | 2.80 yd         | 3 yd            |
| <b>BUILDING 'B'</b>                        | <b>REQUIRED</b> | <b>PROVIDED</b> |
| GARBAGE @ 0.110 cu yd per unit             | 22.44 yd        | 24 yd           |
| GMP CONTAINERS @ 0.018 cu yd per unit      | 3.67 yd         | 4 yd            |
| FIBRE CONTAINERS @ 0.038 cu yd per unit    | 7.75 yd         | 8 yd            |
| ORGANICS CONTAINERS @ one 240L per 50 unit | 4.08 yd         | 5 yd            |

ARCHITECT:

**rla/architecture**  
roderick lahey architect inc.  
56 beech street, ottawa, ontario K1S 3J6  
t: 613.724.9932 f: 613.724.1209 rla@architecture.ca

PROJECT TITLE:  
**35 HUNTMAR DRIVE & 21 HUNTMAR DRIVE**

OTTAWA ONTARIO

SHEET TITLE:  
**SITE PLAN**

|                |           |
|----------------|-----------|
| DRAWN          | CHECKED   |
| AK             | RL        |
| SCALE:         | SHEET No. |
| 1:300          |           |
| DATE:          |           |
| March 02, 2019 |           |
| PROJECT No.    |           |
| 1930           |           |

**SP-1**



**METRIC**  
DISTANCES AND ELEVATIONS SHOWN ON THIS PLAN ARE IN METRES  
AND CAN BE CONVERTED TO FEET BY DIVIDING BY 0.3048

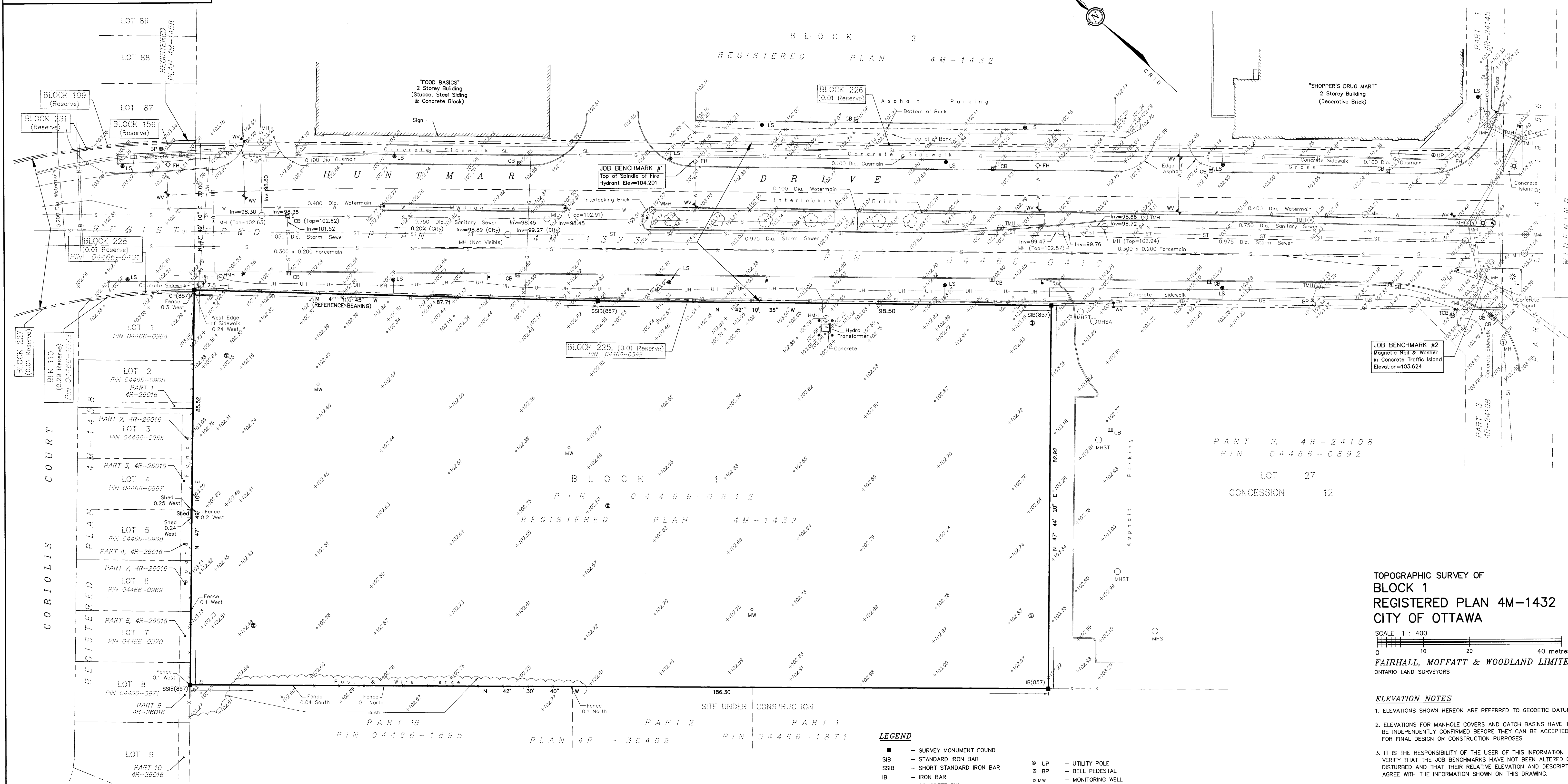

**TOPOGRAPHIC SURVEY OF  
BLOCK 1  
REGISTERED PLAN 4M-1432  
CITY OF OTTAWA**

SCALE 1 : 400

**FAIRHALL, MOFFATT & WOODLAND LIMITED**  
ONTARIO LAND SURVEYORS

**ELEVATION NOTES**

- ELEVATIONS SHOWN HEREON ARE REFERRED TO GEODETIC DATUM.
- ELEVATIONS FOR MANHOLE COVERS AND CATCH BASINS HAVE TO BE INDEPENDENTLY CONFIRMED BEFORE THEY CAN BE ACCEPTED FOR FINAL DESIGN OR CONSTRUCTION PURPOSES.
- IT IS THE RESPONSIBILITY OF THE USER OF THIS INFORMATION TO VERIFY THAT THE JOB BENCHMARKS HAVE NOT BEEN ALTERED OR DISTURBED AND THAT THEIR RELATIVE ELEVATION AND DESCRIPTION AGREE WITH THE INFORMATION SHOWN ON THIS DRAWING.

**LEGEND**

|      |                              |      |                       |
|------|------------------------------|------|-----------------------|
| ■    | - SURVEY MONUMENT FOUND      | ⊗ UP | - UTILITY POLE        |
| SIB  | - STANDARD IRON BAR          | ⊗ BP | - BELL PEDESTAL       |
| SSIB | - SHORT STANDARD IRON BAR    | ⊗ MW | - MONITORING WELL     |
| IB   | - IRON BAR                   | ⊗    | - BOREHOLE            |
| CP   | - CONCRETE PIN               | ⊗    | - BOLLARD             |
| DIA. | - DIAMETER                   | ⊗    | - GUY WIRE AND ANCHOR |
| BLK  | - BLOCK                      | ⊗    | - SIGN                |
| PIN  | - PROPERTY IDENTIFIER NUMBER | ⊗    | - DECIDUOUS TREE      |
| CB   | - CATCH BASIN                | ⊗    | - CURB                |
| MH   | - MANHOLE                    | ⊗    | - GASMAIN             |
| MHST | - STORM MANHOLE              | ⊗    | - SANITARY SEWER      |
| MHSA | - SANITARY MANHOLE           | ⊗    | - WATERMAIN           |
| MWH  | - WATER MANHOLE              | ⊗    | - STORM SEWER         |
| TMH  | - TRAFFIC MANHOLE            | ⊗    | - UNDERGROUND BELL    |
| HMH  | - HYDRO MANHOLE              | ⊗    | - UNDERGROUND HYDRO   |
| FH   | - FIRE HYDRANT               | ⊗    | - STREET LIGHTING     |
| TCB  | - TRAFFIC CONTROL BOX        | ⊗    | - ROGERS CABLE        |
| WV   | - WATER VALVE                | ⊗    | - TRAFFIC             |
| TL   | - TRAFFIC LIGHT              | ⊗    | - EDGE OF TREES       |
| LS   | - LAMP STANDARD              |      |                       |

**UTILITY NOTES**

- THIS DRAWING CANNOT BE ACCEPTED AS ACKNOWLEDGING ALL OF THE UNDERGROUND UTILITIES AND IT WILL BE THE RESPONSIBILITY OF THE USER TO CONTACT THE RESPECTIVE UTILITY AUTHORITIES FOR CONFIRMATION OR LOCATION.
- UNDERGROUND UTILITIES, AS REPORTED ON THIS DRAWING, ARE NOT BASED ON AN ACTUAL 'FIELD LOCATE' BY THE RESPECTIVE UTILITY AGENCIES BUT HAVE BEEN COMPILED FROM DATA OBTAINED FROM THE FOLLOWING SOURCE:  
a) CITY OF OTTAWA PUBLIC UTILITIES REGISTRY
- BEFORE ANY WORK INVOLVING PROBING, EXCAVATING, ETC., A FIELD LOCATION OF UNDERGROUND PLANT BY THE PERTINENT UTILITY AUTHORITY IS MANDATORY.

**NOTES**

- THE SURVEY REPRESENTED BY THIS PLAN WAS COMPLETED ON AUGUST 25, 2015.
- THE SURVEY REPRESENTED BY THIS PLAN WAS UPDATED ON JULY 29, 2019.
- BEARINGS ARE GRID REFERRED TO THE SOUTHERLY LIMIT OF HUNTMAR DRIVE SHOWN ON PLAN 4M-1432 AS HAVING A BEARING OF N41°11'45"W.

**SURVEYOR'S CERTIFICATE**

I CERTIFY THAT:  
1. THIS SURVEY AND PLAN ARE CORRECT AND IN ACCORDANCE WITH THE SURVEYS ACT, THE SURVEYORS ACT AND THE REGULATIONS MADE UNDER THEM.  
2. THE SURVEY WAS COMPLETED ON JULY 29, 2019.

DATE: 2019/08/07  
JOHN H. GUTRI  
ONTARIO LAND SURVEYOR

**Fairhall  
Moffatt &  
Woodland**  
LIMITED  
ONTARIO LAND SURVEYORS

100-600 TERRY FOX DRIVE, KANATA, ONTARIO K2L 4B6  
TEL: (613) 591-2580 FAX: (613) 591-1495  
www.fmw.on.ca

JOB No. 224700  
E 350751, N 5016205  
REFERENCE No. 4(c) - 4M - 1432  
2247\_topo-up.dwg

© COPYRIGHT 2019. REPRODUCTION, ALTERATION OR DISTRIBUTION OF THIS PLAN WITHOUT THE WRITTEN CONSENT OF FAIRHALL, MOFFATT & WOODLAND LIMITED IS PROHIBITED.

THIS IS NOT A VALID COPY UNLESS EMBOSSED WITH SEAL

## 21 Huntmar Drive Pre-Consultation Meeting Minutes

Location: Room 4106E, City Hall  
Date: July 31, 2019, 3pm to 4pm

| Attendee          | Role                             | Organization              |
|-------------------|----------------------------------|---------------------------|
| Mark Young        | Planner                          | City of Ottawa            |
| Julie Candow      | Project Manager (Infrastructure) |                           |
| Mike Giampa       | Project Manager (Transportation) |                           |
| Matthew Ippersiel | Planner (Urban Design)           |                           |
| Sami Rehman       | Planner (Environmental)          |                           |
| Samantha Gatchene | Planning Assistant               |                           |
| Ron Richards      | Owner's Representative           | North American            |
| Paul Ferarro      | Owner's Representative           |                           |
| Abhinav Sukumar   | Architect                        | Roderick Lahey Architects |

### Comments from Applicant

1. The applicant is proposing the development of two (2) five-storey mid-rise buildings at 21 Huntmar Drive. The buildings would be residential apartments with 210 units total.
2. 334 underground parking spaces and 12 surface parking spaces would be provided.
3. One new access point is proposed off of Huntmar Drive. This driveway would lead to the surface parking lot on the interior of site, providing access to both buildings and the underground parking.

### Planning Comments

1. This is a pre-consultation for a Site Plan Control application, Complex, subject to Public Consultation. Application form, timeline and fees can be found [here](#).
2. With regards to maximum building height, the Zoning By-law permits a maximum of 11 metres in areas up to 20 metres from a property line abutting a residential zone.
3. Cash-in-lieu of parkland and associated appraisal fee will be required as a condition of approval as per the [Parkland Dedication By-law](#).

### Urban Design Comments

1. The general built form approach and the L-shaped building footprints framing the street are supported and it is recommended that the applicant pursue this approach.
2. The ground-oriented units and proposed individual walkways are supported.
3. As the site plan and landscape plan progress, be mindful of demonstrating how the pedestrian pathway network will be properly lit and CPTED design principles have been applied.

### Engineering Comments

1. The Servicing Study Guidelines for Development Applications are available at the following address: <https://ottawa.ca/en/city-hall/planning-and-development/information-developers/development-application-review-process/development-application-submission/guide-preparing-studies-and-plans>
2. Servicing and site works shall be in accordance with the following documents:
  - ⇒ Ottawa Sewer Design Guidelines (October 2012)
  - ⇒ Ottawa Design Guidelines – Water Distribution (2010)
  - ⇒ Geotechnical Investigation and Reporting Guidelines for Development Applications in the City of Ottawa (2007)
  - ⇒ City of Ottawa Slope Stability Guidelines for Development Applications (revised 2012)
  - ⇒ City of Ottawa Environmental Noise Control Guidelines (January 2016)
  - ⇒ City of Ottawa Park and Pathway Development Manual (2012)
  - ⇒ City of Ottawa Accessibility Design Standards (2012)
  - ⇒ Ottawa Standard Tender Documents (latest version)
  - ⇒ Ontario Provincial Standards for Roads & Public Works (2013)
3. Record drawings and utility plans are also available for purchase from the City (Contact the City's Information Centre by email at [InformationCentre@ottawa.ca](mailto:InformationCentre@ottawa.ca) or by phone at (613) 580-2424 x.44455).
4. The Stormwater Management Criteria for the subject site is to be based on the following:
  - i. The allowable storm release rate for the subject site is limited to 85 L/s/ha as per the Kanata West Master Servicing Study.
  - ii. Onsite storm runoff, in excess of the allowable release rate, and up to the 1:100 year storm event must be detained on site.

- iii. Post development infiltration rates are to be increased by 25 percent above the pre-development infiltration rates as per the Kanata West Master Servicing Study.
  - iv. Quantity control to be provided by the downstream stormwater management facility and/or as determined by the Mississippi Valley Conservation Authority (MVCA). Please include correspondence from the MVCA in the stormwater management report.
  - v. A letter of acknowledgment will be required to be obtained from Mattamy to allow storm flows from 21 Huntmar Drive to discharge to Mattamy's temporary SWM pond, within Mattamy's Phase 5 development.
5. No sanitary sewer capacity constraints were identified on Huntmar Drive during the initial review of the concept plan. A sanitary sewer connection to the existing 750mm diameter sanitary sewer within Huntmar Drive is acceptable.
6. As per Section 4.3.1 of the Water Design Guidelines, two watermain connections will be required to provide a looped connection if the basic day demand is greater than 50 m<sup>3</sup>/day (approx. 50 homes).
7. Water Boundary condition requests must include the location of the service and the expected loads required by the proposed development. Please provide the following information:
- i. Location of service
  - ii. Type of development and the amount of fire flow required (as per FUS, 1999).
  - iii. Average daily demand: \_\_\_ l/s.
  - iv. Maximum daily demand: \_\_\_ l/s.
  - v. Maximum hourly daily demand: \_\_\_ l/s.
8. An MECP Environmental Compliance Approval is not anticipated to be required for the subject site.
9. Phase 1 ESAs and Phase 2 ESAs must conform to clause 4.8.4 of the Official Plan that requires that development applications conform to Ontario Regulation 153/04.

Should you have any questions or require additional information, please contact me directly at (613) 580-2424, x13850 or by email at [Julie.Candow@ottawa.ca](mailto:Julie.Candow@ottawa.ca).

### Transportation Comments

1. A TIA is triggered for this site and they should proceed to Scoping (Step 2). This should be done prior to an application.
2. The signalization of the Huntmar access should be further explored.
3. The application will not be deemed complete until the submission of the draft Step 1-4, including the functional draft RMA package (if applicable).
4. A noise study is required.

### Environmental Planning

1. The subject property is within the adjacency distance to the Natural Heritage Systems (See OP Section 2.4.2 and Schedule L3) and thus, triggers a requirement for an Environmental Impact Statement (EIS), as per OP Section 4.7.8. Given that butternut trees were identified in the adjacent woodlot, there is a potential for butternuts to be on the subject property. The field on the subject property may also host other endangered or threatened species.
2. The EIS should address and demonstrate no negative impacts on the NHS and to determine the presence of endangered or threatened species or their habitats on the subject property. Further details on the EIS requirements can be found in OP section 4.7.8 and the EIS guidelines.  
[https://documents.ottawa.ca/sites/default/files/documents/eis\\_guidelines2015\\_en.pdf](https://documents.ottawa.ca/sites/default/files/documents/eis_guidelines2015_en.pdf)

### Forestry

1. Any tree information can be combined into the EIS.
2. A tree permit is required if any trees need to be cut that are 10cm or larger in diameter.

### Parks Planning

1. Recommend there is a pathway connection to the Poole Creek corridor (UNA 185);
2. Assumption that play area(s) are to remain as private ownership.
3. Although play area(s) are private, recommend the Owner adhere to City specifications and standards for play area(s) design, construction and maintenance.



4. The site is located within Kanata West CDP area, therefore 100% CIL direction to District Park

#### Mississippi Valley Conservation Authority

1. There does not appear to be any hazards or heritage features, however it appears to drain into Poole Creek so it is enhanced level of treatment and we generally recommend using LIDs.
2. The Master Serving Study for Kanata West (SWM) indicates infiltration targets 50 – 70 mm/yr., but it should be confirmed.

#### Requested Plans and Studies

1. A list of required plans and studies required for a complete Site Plan Control application have been attached.

Please refer to the links to "[Guide to preparing studies and plans](#)" and [fees](#) for general information. Additional information is available related to [building permits, development charges, and the Accessibility Design Standards](#). Be aware that other fees and permits may be required, outside of the development review process. You may obtain background drawings by contacting [informationcentre@ottawa.ca](mailto:informationcentre@ottawa.ca).

These pre-con comments are valid for one year. If you submit a development application(s) after this time, you may be required to meet for another pre-consultation meeting and/or the submission requirements may change. You are as well encouraged to contact us for a follow-up meeting if the plan/concept will be further refined.

Please contact me at [Mark.Young@ottawa.ca](mailto:Mark.Young@ottawa.ca) or at 613-580-2424 extension 41396 if you have any questions.

Sincerely,



Mark Young, MCIP RPP  
Planner III  
Development Review - West

# **APPENDIX B**

- Watermain Demand Calculation Sheet
- FUS Fire Flow Calculation
- Watermain Boundary Condition
- C-001 General Plan
- C-010 Details Plan



**IBI GROUP**  
 333 PRESTON STREET  
 OTTAWA, ON  
 K1S 5N4

**WATERMAIN DEMAND CALCULATION SHEET**

PROJECT : 21 HUNTMAR DR  
 LOCATION : City of Ottawa  
 DEVELOPER : NORTH AMERICAN DEVELOPMENT GROUP

FILE: 127134-6.4.4  
 DATE PRINTED: 2021-02-08  
 DESIGN: 2021-01-19  
 PAGE: 1 OF 1

| NODE         | RESIDENTIAL |            |          |            | NON-RESIDENTIAL |             |                          | AVERAGE DAILY DEMAND (l/s) |             |             | MAXIMUM DAILY DEMAND (l/s) |             |             | MAXIMUM HOURLY DEMAND (l/s) |             |              | FIRE DEMAND (l/min) |
|--------------|-------------|------------|----------|------------|-----------------|-------------|--------------------------|----------------------------|-------------|-------------|----------------------------|-------------|-------------|-----------------------------|-------------|--------------|---------------------|
|              | UNITS       |            |          | POP'N      | INDTRL (ha.)    | COMM. (ha.) | RETAIL (m <sup>2</sup> ) | Res.                       | Non-res.    | Total       | Res.                       | Non-res.    | Total       | Res.                        | Non-res.    | Total        |                     |
|              | 1bd         | 2bd        | 3bd      |            |                 |             |                          |                            |             |             |                            |             |             |                             |             |              |                     |
| BUILDING A   | 38          | 102        |          | 267        |                 |             |                          | 0.87                       | 0.00        | 0.87        | 2.17                       | 0.00        | 2.17        | 4.77                        | 0.00        | 4.77         |                     |
| BUILDING B   | 111         | 93         | 0        | 351        |                 |             |                          | 1.14                       | 0.00        | 1.14        | 2.84                       | 0.00        | 2.84        | 6.25                        | 0.00        | 6.25         |                     |
| <b>Total</b> | <b>149</b>  | <b>195</b> | <b>0</b> | <b>618</b> |                 |             |                          | <b>2.00</b>                | <b>0.00</b> | <b>2.00</b> | <b>5.01</b>                | <b>0.00</b> | <b>5.01</b> | <b>11.02</b>                | <b>0.00</b> | <b>11.02</b> | <b>11,000</b>       |

**ASSUMPTIONS**

| <u>RESIDENTIAL DENSITIES</u>  | <u>AVG. DAILY DEMAND</u>             | <u>MAX. HOURLY DEMAND</u>            |
|---|--------------------------------------|--------------------------------------|
| One-bedroom/Studio (1bd) 1.4 p / p / u  | Residential:** 280 l / cap / day     | Residential: 1,540 l / cap / day     |
| Two-bedroom (2bd) 2.1 p / p / u   | Industrial: l / ha / day             | Industrial: l / ha / day             |
| Three-bedroom (3bd) 2.8 p / p / u   | Commercial: l / ha / day             | Commercial: l / ha / day             |
|   | Retail: l / 1000m <sup>2</sup> / day | Retail: l / 1000m <sup>2</sup> / day |
| ** Residential Daily Demand reduced to coincide with current waste water guidelines | <u>MAX. DAILY DEMAND</u>             | <u>FIRE FLOW</u>                     |
|   | Residential: 700 l / cap / day       | From FUS Calculation 11,000 l / min  |
|   | Industrial: l / ha / day             |                                      |
|   | Commercial: l / ha / day             |                                      |
|   | Retail: l / 1000m <sup>2</sup> / day |                                      |

**Fire Flow Requirement from Fire Underwriters Survey - 21 Huntmar Drive**

**Building A**

|                         |                            |
|-------------------------|----------------------------|
| Floor Area (1 & 2)      | 4,682 m <sup>2</sup>       |
| 50% Floor Area (3 to 8) | 4,557                      |
| <b>Total Floor Area</b> | <b>9,239 m<sup>2</sup></b> |

$F = 220C\sqrt{A}$

|     |                      |     |                     |
|-----|----------------------|-----|---------------------|
| C   | 0.6                  | C = | 1.5 wood frame      |
| A   | 9,239 m <sup>2</sup> |     | 1.0 ordinary        |
|     |                      |     | 0.8 non-combustible |
| F   | 12,688 l/min         |     | 0.6 fire-resistive  |
| use | 13,000 l/min         |     |                     |

| Floor        | Area (m <sup>2</sup> ) | Two Largest | Floors Above at |
|--------------|------------------------|-------------|-----------------|
| 1            | 2341                   | 2341        |                 |
| 2            | 2341                   | 2341        |                 |
| 3            | 2341                   |             | 1170.5          |
| 4            | 2341                   |             | 1170.5          |
| 5            | 2341                   |             | 1170.5          |
| 6            | 2091                   |             | 1045.5          |
|              |                        |             |                 |
|              |                        |             |                 |
| <b>Total</b> | <b>13796</b>           | <b>4682</b> | <b>4557</b>     |

**(Note:** For fire-resistive buildings, consider two largest adjoining floors plus 50% of each of any floors immediately above them

Occupancy Adjustment

|            |              |                          |
|------------|--------------|--------------------------|
|            |              | -25% non-combustible     |
|            |              | -15% limited combustible |
| Use        | -15%         | 0% combustible           |
|            |              | +15% free burning        |
| Adjustment | -1950 l/min  | +25% rapid burning       |
| Fire flow  | 11,050 l/min |                          |

Sprinkler Adjustment

|            |             |                                   |
|------------|-------------|-----------------------------------|
|            |             | -30% system conforming to NFPA 13 |
|            |             | -50% complete automatic system    |
| Use        | -30%        |                                   |
| Adjustment | -3315 l/min |                                   |

Exposure Adjustment

| Building Face | Separation (m) | Adjacent Exposed Wall |         |            | Exposure Charge * |
|---------------|----------------|-----------------------|---------|------------|-------------------|
|               |                | Length                | Stories | L*H Factor |                   |
| north         | 40.0           |                       |         |            | 5%                |
| east          | 25.5           | 20.0                  | 6       | 120        | 9%                |
| south         | > 45           |                       |         |            | 0%                |
| west          | 28.0           | 100.0                 | 2       | 200        | 15%               |

Total 29%

Adjustment 3,205 l/min

Total adjustments (111) l/min

Fire flow 10,940 l/min

**Use 11,000 l/min**

**183 l/s**

\* Exposure charges from Technical Bulletin ISTB 2018-02 Appendix H (ISO Method)

**Fire Flow Requirement from Fire Underwriters Survey - 21 Huntmar Drive**

**Building B**

|                         |                             |
|-------------------------|-----------------------------|
| Floor Area (1 & 2)      | 5,936 m <sup>2</sup>        |
| 50% Floor Area (3 to 8) | 5,793                       |
| <b>Total Floor Area</b> | <b>11,729 m<sup>2</sup></b> |

$F = 220C\sqrt{A}$

|     |                       |     |                     |
|-----|-----------------------|-----|---------------------|
| C   | 0.6                   | C = | 1.5 wood frame      |
| A   | 11,729 m <sup>2</sup> |     | 1.0 ordinary        |
|     |                       |     | 0.8 non-combustible |
| F   | 14,296 l/min          |     | 0.6 fire-resistive  |
| use | 14,000 l/min          |     |                     |

| Floor        | Area (m <sup>2</sup> ) | Two Largest Floor | Floors Above at 50% |
|--------------|------------------------|-------------------|---------------------|
| 1            | 2968                   | 2968              |                     |
| 2            | 2968                   | 2968              |                     |
| 3            | 2968                   |                   | 1484                |
| 4            | 2968                   |                   | 1484                |
| 5            | 2968                   |                   | 1484                |
| 6            | 2682                   |                   | 1341                |
|              |                        |                   |                     |
|              |                        |                   |                     |
| <b>Total</b> | <b>17522</b>           | <b>5936</b>       | <b>5793</b>         |

(Note: For fire-resistive buildings, consider two largest adjoining floors plus 50% of each of any floors immediately above them up to eight.)

Occupancy Adjustment

|            |              |                          |
|------------|--------------|--------------------------|
|            |              | -25% non-combustible     |
|            |              | -15% limited combustible |
| Use        | -15%         | 0% combustible           |
|            |              | +15% free burning        |
| Adjustment | -2100 l/min  | +25% rapid burning       |
| Fire flow  | 11,900 l/min |                          |

Sprinkler Adjustment

|            |             |                                   |
|------------|-------------|-----------------------------------|
|            |             | -30% system conforming to NFPA 13 |
|            |             | -50% complete automatic system    |
| Use        | -30%        |                                   |
| Adjustment | -3570 l/min |                                   |

Exposure Adjustment

| Building Face | Separation (m) | Adjacent Exposed Wall |         |            | Exposure Charge * |
|---------------|----------------|-----------------------|---------|------------|-------------------|
|               |                | Length                | Stories | L*H Factor |                   |
| north         | > 45           |                       |         |            | 0%                |
| east          | > 45           |                       |         |            | 0%                |
| south         | > 45           |                       |         |            | 0%                |
| west          | 25.5           | 20.0                  | 6       | 120        | 9%                |

Total 9%

Adjustment 1,071 l/min

Total adjustments (2,499) l/min

Fire flow 9,401 l/min

**Use 9,000 l/min**  
**150 l/s**

\* Exposure charges from Technical Bulletin ISTB 2018-02 Appendix H (ISO Method)

## Boundary Conditions 21 Huntmar Drive

### Provided Information

| Scenario             | Demand |        |
|----------------------|--------|--------|
|                      | L/min  | L/s    |
| Average Daily Demand | 120    | 2.00   |
| Maximum Daily Demand | 301    | 5.01   |
| Peak Hour            | 661    | 11.02  |
| Fire Flow Demand #1  | 11,000 | 183.33 |

### Location

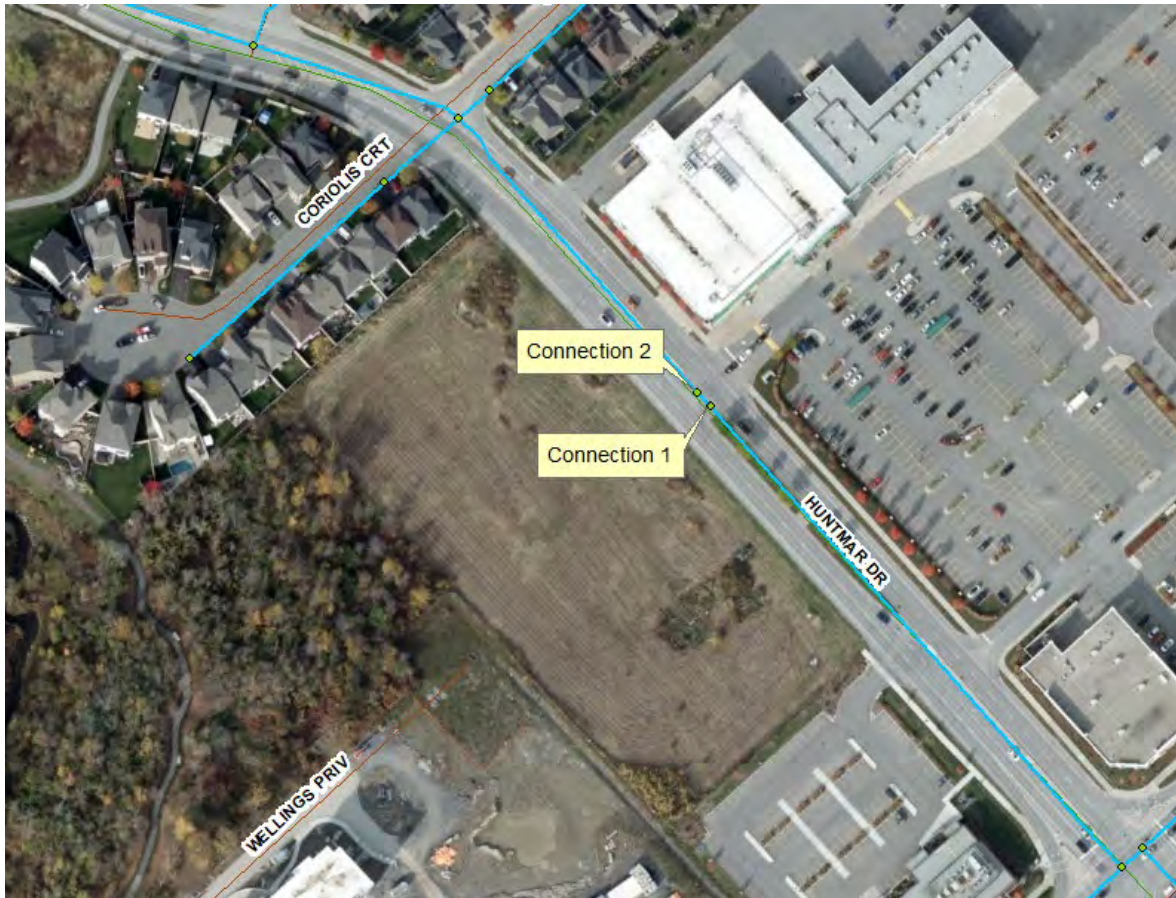

### Results

#### Connection 1 – Huntmar Dr.

| Demand Scenario     | Head (m) | Pressure <sup>1</sup> (psi) |
|---------------------|----------|-----------------------------|
| Maximum HGL         | 161.1    | 82.4                        |
| Peak Hour           | 156.7    | 76.0                        |
| Max Day plus Fire 1 | 155.9    | 74.9                        |

Ground Elevation = 103.2 m

## Connection 2 – Huntmar Dr.

| Demand Scenario     | Head (m) | Pressure <sup>1</sup> (psi) |
|---------------------|----------|-----------------------------|
| Maximum HGL         | 161.1    | 82.4                        |
| Peak Hour           | 156.7    | 76.0                        |
| Max Day plus Fire 1 | 155.9    | 74.9                        |

Ground Elevation = 103.2 m

## Notes

1. Two service connection with a separation valve in-between.
2. As per the Ontario Building Code in areas that may be occupied, the static pressure at any fixture shall not exceed 552 kPa (80 psi.) Pressure control measures to be considered are as follows, in order of preference:
  - a. If possible, systems to be designed to residual pressures of 345 to 552 kPa (50 to 80 psi) in all occupied areas outside of the public right-of-way without special pressure control equipment.
  - b. Pressure reducing valves to be installed immediately downstream of the isolation valve in the home/ building, located downstream of the meter so it is owner maintained.

## **Disclaimer**

*The boundary condition information is based on current operation of the city water distribution system. The computer model simulation is based on the best information available at the time. The operation of the water distribution system can change on a regular basis, resulting in a variation in boundary conditions. The physical properties of watermains deteriorate over time, as such must be assumed in the absence of actual field test data. The variation in physical watermain properties can therefore alter the results of the computer model simulation. Fire Flow analysis is a reflection of available flow in the watermain; there may be additional restrictions that occur between the watermain and the hydrant that the model cannot take into account.*



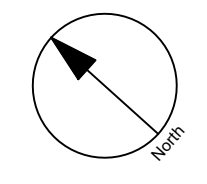

| ICD LOCATION (MH #) | RELEASE RATE (L/s) | HEAD (m) | ICD               |
|---------------------|--------------------|----------|-------------------|
| SWM tank            | 41.05              | 1.29     | Tempest LMF plate |
| CBM#2               | 10.66              | 0.71     | Tempest LMF plate |

**North American**  
DEVELOPMENT GROUP

2851 John Street, Suite One, Markham, Ontario L3R 5R7 T: 905-968-3185

**COPYRIGHT**  
This drawing has been prepared solely for the intended use, any reproduction or distribution for any purpose other than authorized by IBI Group is forbidden. When dimensions shall have precedence over scaled dimensions. Contractors shall verify and be responsible for all dimensions and conditions on the job, and IBI Group shall be informed of any variations from the dimensions and conditions shown on the drawing. Shop drawings shall be submitted to IBI Group for general confirmation before proceeding with fabrication.

**IBI Group Professional Services (Canada) Inc.**  
a member of the IBI Group of companies

**ISSUES**

| No. | DESCRIPTION    | DATE       |
|-----|----------------|------------|
| 1   | ISSUED FOR SPA | 2021-02-16 |
| 2   | SPA SUBMISSION | 2021       |

**NOT FOR CONSTRUCTION**

FOR NOTES, LEGEND



**CONSULTANTS**

Project Coordinator:  
North American Development Group

Architect:  
RLA Architecture

Surveyor:  
Fairhall, Moffatt and Woodland Ltd.

Geotechnical:  
Paterson Group

Traffic:  
JD Halpenny & Assoc.

Electrical:  
Hammerschlag & Joffe Inc.

Landscape:  
NAK Design Strategies

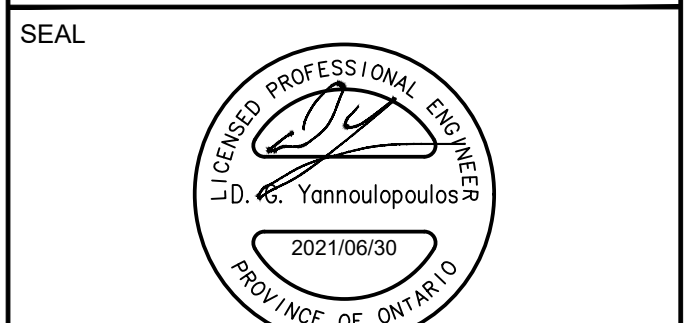

**IBI GROUP**  
Suite 400 - 333 Preston Street  
Ottawa ON K1S 5N4 Canada  
Tel: 613 225 1311 / 613 241 3300 Fax: 613 225 9868  
ibigroup.com

**PROJECT**  
21/35 HUNTMAR DRIVE

**PROJECT NO:**  
127134

**DRAWN BY:**  
EH

**CHECKED BY:**  
DGY

**PROJECT MGR:**  
DGY

**APPROVED BY:**  
DGY

**SHEET TITLE**  
GENERAL PLAN OF SERVICES

**SHEET NUMBER**  
C-001

**ISSUE**  
1

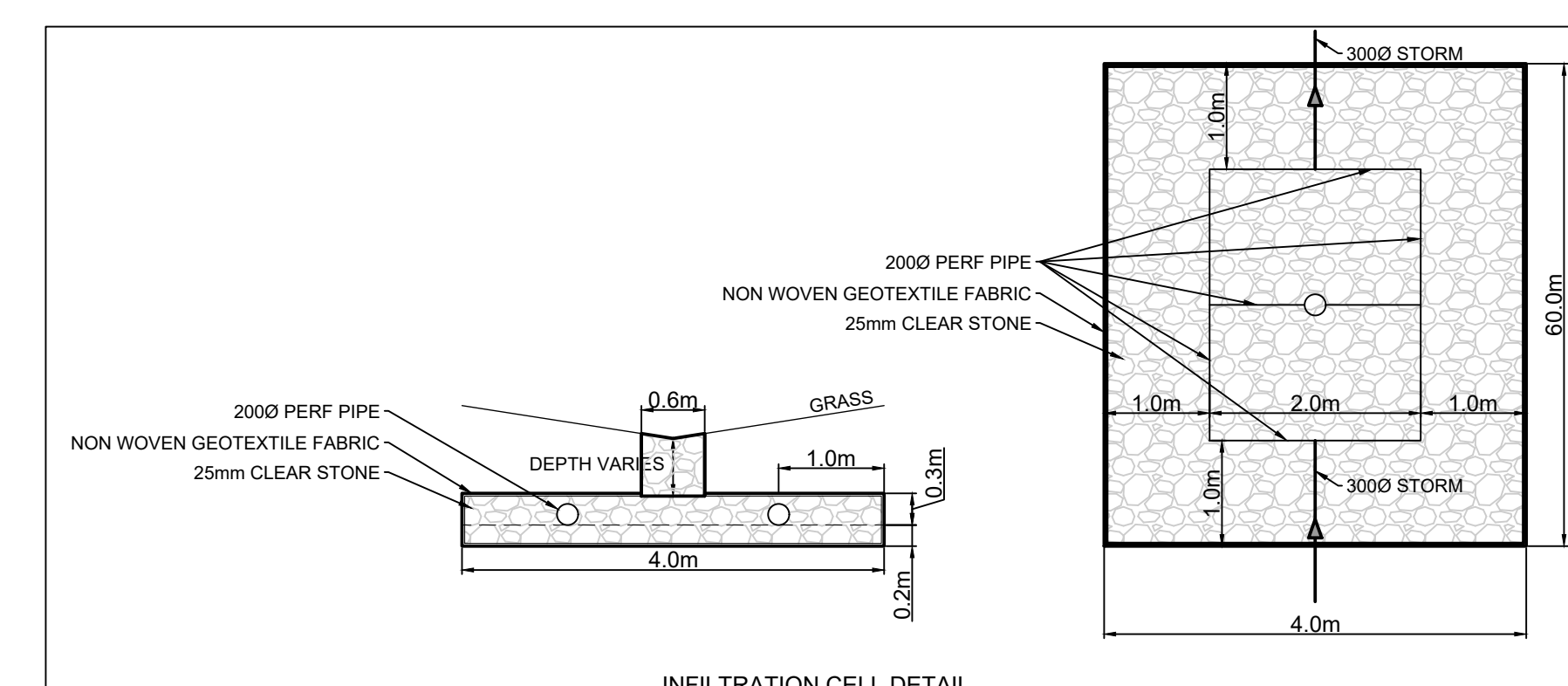
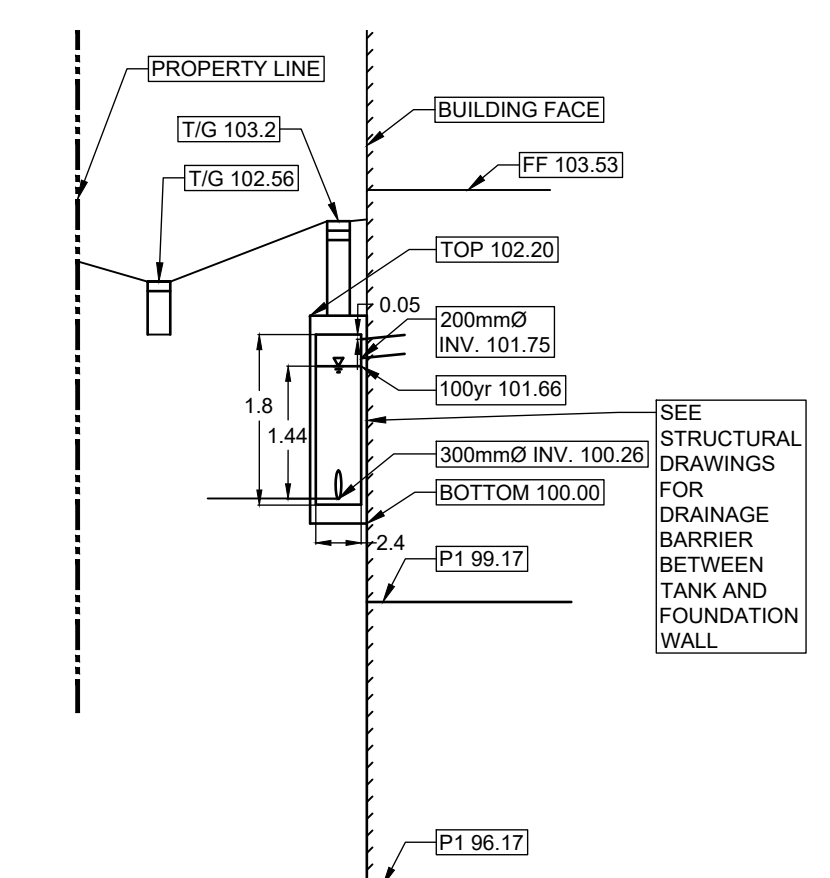
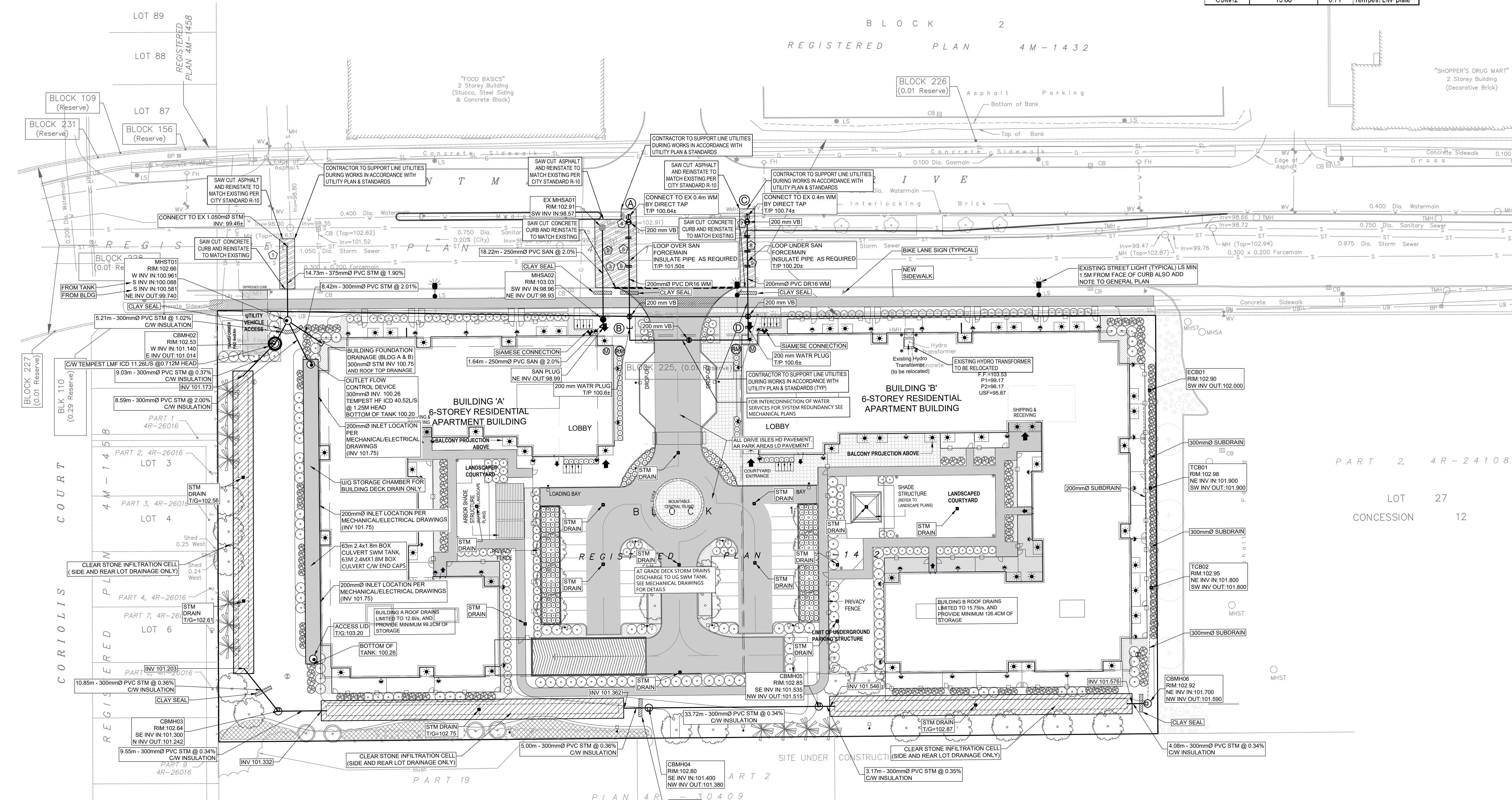

CITY FILE No. D07-12-21-0035  
Scale Check  
File Location: \\127134\_21\_huntmar\7\_0\_Production\02\_Design\04\_Civil\Sheets\C-001\_GENERAL PLAN OF SERVICES.dwg Last Saved: July 5, 2021, 1:20:34 PM by Eric Henne Printed: Monday, July 5, 2021, 1:20:34 PM by Eric Henne



| CROSSING SCHEDULE |                |         |                |                    |                |
|-------------------|----------------|---------|----------------|--------------------|----------------|
| 1                 | EX300x200 mm   | SAN     | 0.681 m        | CLEARANCE OVER     | 375 mm ø STM   |
| 2                 | EX975 mm ø STM | 1       | 0.262 m        | CLEARANCE OVER     | 250 mm ø SAN   |
| 3                 | EX300x200 mm   | SAN     | 1.711 m        | CLEARANCE OVER     | 250 mm ø SAN   |
| 4                 | 200 mm ø W/M   | 1       | 1.324 m        | CLEARANCE OVER     | EX750 mm ø SAN |
| 5                 | 200 mm ø W/M   | 0.482 m | CLEARANCE OVER | EX975 mm ø STM     |                |
| 6                 | 200 mm ø W/M   | 0.296 m | CLEARANCE OVER | EX300x200 mm ø SAN |                |
| 7                 | 200 mm ø W/M   | 1.152 m | CLEARANCE OVER | EX750 mm ø SAN     |                |
| 8                 | 200 mm ø W/M   | 0.493 m | CLEARANCE OVER | EX975 mm ø STM     |                |
| 9                 | EX300x200 mm   | SAN     | 0.493 m        | CLEARANCE OVER     | 200 mm ø W/M   |

| PAVEMENT STRUCTURE **   |  |
|---|--|
| <b>CAR ONLY PARKING AREAS:</b>  |  |
| 50mm WEAR COURSE - HL-3 OR SUPERPAVE 12.5 ASPHALTIC CONCRETE  |  |
| 150mm BASE - OPSS GRANULAR "A" CRUSHED STONE  |  |
| 300mm SUBBASE - OPSS GRANULAR "B" TYPE II   |  |
| SUBGRADE - EITHER FILL, IN SITU SOIL, OR OPSS GRANULAR "B" TYPE I OR II MATERIAL PLACED OVER IN SITU SOIL OR FILL |  |
| <b>ACCESS LANES AND HEAVY TRUCK PARKING AREAS</b>   |  |
| 40mm WEAR COURSE - HL-3 OR SUPERPAVE 12.5 ASPHALTIC CONCRETE  |  |
| 50mm BINDER COURSE - HL-8 OR SUPERPAVE 19.0 ASPHALTIC CONCRETE  |  |
| 400mm SUBBASE - OPSS GRANULAR "A" CRUSHED STONE   |  |
| 400mm SUBBASE - OPSS GRANULAR "B" TYPE II   |  |
| SUBGRADE - EITHER FILL, IN SITU SOIL, OR OPSS GRANULAR "B" TYPE I OR II MATERIAL PLACED OVER IN SITU SOIL OR FILL |  |

\*\* REFER TO GEOTECHNICAL REPORT BY PATERSON GROUP. REV # 2 DATED DECEMBER 20, 2020

**DRAWING NOTES**

**1.0 GENERAL**

- CONTRACTOR TO VERIFY ALL DIMENSIONS PRIOR TO CONSTRUCTION.
- DO NOT SCALE DRAWINGS.
- CONTRACTOR TO REPORT ALL DISCOVERIES OF ERRORS, OMISSIONS OR DISCREPANCIES TO THE ARCHITECT OR DESIGN ENGINEER AS APPLICABLE.
- USE ONLY THE LATEST REVISED DRAWINGS OR THOSE THAT ARE MARKED "ISSUED FOR CONSTRUCTION".
- ALL CONSTRUCTION SHALL COMPLY WITH CURRENT CITY OF OTTAWA STANDARDS AND SPECIFICATIONS.
- THIS DRAWING SHALL BE READ IN CONJUNCTION WITH ALL RELEVANT DRAWINGS AND SPECIFICATIONS.
- FOR LEGAL SURVEY INFORMATION REFER TO REGISTERED PLAN FROM FAIRHALL, MOFFATT AND WOODLAND LTD.
- REFER TO SITE PLAN BY RLA ARCHITECTURE.
- CONTRACTOR TO IMPLEMENT EROSION AND SEDIMENT CONTROL MEASURES AS IDENTIFIED IN THE EROSION AND SEDIMENT CONTROL PLAN TO THE SATISFACTION OF THE CITY OF OTTAWA. PRIOR TO UNDERTAKING ANY SITE ALTERATIONS (FILLING, GRADING, REMOVAL OF VEGETATION, ETC.) DURING ALL PHASES OF THE SITE PREPARATION AND CONSTRUCTION THE MEASURES ARE TO BE MAINTAINED TO THE SATISFACTION OF THE ENGINEER AND CITY OF OTTAWA IN ACCORDANCE WITH THE BEST MANAGEMENT PRACTICES FOR EROSION AND SEDIMENT CONTROL. SHOULD ANY ADDITIONAL MEASURES BE REQUIRED TO ADDRESS FIELD CONDITIONS THEY SHALL BE INSTALLED AS DIRECTED BY THE ENGINEER OR THE CITY OF OTTAWA. SUCH ADDITIONAL MEASURES MAY INCLUDE BUT NOT BE LIMITED TO INSTALLATION OF SEDIMENT CAPTURE FILTER SOCKS WITHIN MANHOLES AND CATCHBASINS TO PREVENT SEDIMENT FROM ENTERING THE STRUCTURE AND INSTALLATION AND MAINTENANCE OF A LIGHT DUTY SILT FENCE BARRIER AS REQUIRED.
- ALL IRON WORK ELEVATIONS SHOWN ARE APPROXIMATE AND ARE SUBJECT TO MINOR ADJUSTMENTS AS DETERMINED BY THE ENGINEER.
- ALL CONCRETE CURBS AND SIDEWALKS TO CONFORM TO O.P.S. AND CONSTRUCTED TO CITY STANDARDS. ALL ONSITE CURBS TO BE BARRIER TYPE, WITH DEPRESSIONS AS NOTED.
- ALL CONCRETE SHALL BE "NORMAL PORTLAND CEMENT" IN ACCORDANCE WITH O.P.S.S. 1350 AND SHALL ACHIEVE A MINIMUM STRENGTH OF 30MPa AT 28 DAYS.
- ALL CONSTRUCTION TRAFFIC TO ACCESS SITE FROM HUNTMAR DRIVE.
- FOR GEOTECHNICAL REPORT SEE GEOTECHNICAL INVESTIGATION BY PATERSON GROUP. REPORT PG5006-1 REVISION 2 DATED DECEMBER 1, 2020. EXISTING MONITORING WELLS DOCUMENTED IN SECTION 4.1 OF THE GEOTECHNICAL INVESTIGATION WILL BE DECOMMISSIONED PER CODE REQUIREMENTS PRIOR TO COMMENCING CONSTRUCTION.
- CONTRACTOR TO PROTECT EXISTING INFRASTRUCTURE AND PROPERTY SUCH AS TREES, PARKING METERS, SIDEWALKS, CURBS, ASPHALT, AND STREET SIGNS FROM DAMAGE DURING CONSTRUCTION. CONTRACTOR TO PAY THE COST TO REINSTATE OR REPLACE ANY DAMAGED INFRASTRUCTURE OR PROPERTY TO THE SATISFACTION OF THE CITY.
- THE POSITION OF POLE LINES, CONDUITS, WATERMAIN, SEWERS, AND OTHER UNDERGROUND AND ABOVEGROUND UTILITIES AND STRUCTURES ARE NOT NECESSARILY SHOWN ON THE CONTRACT DRAWINGS, AND WHERE SHOWN, THE ACCURACY OF THE POSITION OF SUCH UTILITIES AND STRUCTURES IS NOT GUARANTEED. BEFORE STARTING WORK THE CONTRACTOR SHALL INFORM ITSELF OF THE EXACT LOCATION OF ALL SUCH UTILITIES AND STRUCTURES, SHALL PROTECT ALL UTILITIES AND STRUCTURES, AND SHALL ASSUME ALL LIABILITY FOR DAMAGE TO THEM.
- CONTRACTOR TO SUPPLY SUITABLE FILL MATERIAL WHERE REQUIRED TO ROUGH GRADE THE SITE. ALL IMPORTED FILL MATERIAL TO BE CERTIFIED AS ACCEPTABLE BY THE GEOTECHNICAL ENGINEER.
- CONTRACTOR TO HAUL EXCESS MATERIAL OFFSITE AS NECESSARY TO GRADE SITE TO MEET THE PROPOSED GRADES. ALL EXCESS MATERIAL TO BE HAULED OFFSITE AND DISPOSED OF AT AN APPROVED DUMP SITE. SHOULD THE CONTRACTOR DISCOVER ANY HAZARDOUS MATERIAL, CONTRACTOR IS TO NOTIFY ENGINEER. ENGINEER TO DETERMINE APPROPRIATE DISPOSAL METHOD/LOCATION.
- FILL MATERIAL WITHIN THE PARKING LOT AND BUILDING PAD AREAS, AND SUPPORTING BUILDING FOUNDATIONS SHALL BE COMPACTED TO 98% STANDARD MODIFIED PROCTOR DENSITY AND TO THE SATISFACTION OF THE GEOTECHNICAL ENGINEER.
- ALL COMPACTION METHODS TO BE PERFORMED TO THE SATISFACTION OF THE GEOTECHNICAL ENGINEER TO INCLUDE BUT NOT BE LIMITED TO THE THICKNESS OF LIFTS, AND COMPACTION EQUIPMENT USED.
- ALL DISTURBED BOULEVARDS TO BE REINSTATED WITH SOD ON 100mm TOPSOIL.
- UTILITY DUCTS TO BE INSTALLED PRIOR TO ROAD BASE CONSTRUCTION.
- CLAY DIKES TO BE INSTALLED WHERE INDICATED ON THE DRAWINGS OR AS APPROVED AND DIRECTED BY THE GEOTECHNICAL ENGINEER ALL IN ACCORDANCE WITH CITY OF OTTAWA STANDARDS AND SPECIFICATIONS.
- BACKWATER VALES, PER CITY STANDARDS S14, S14.1 AND S14.2 RE TO BE INSTALLED FOR ALL STORM AND SANITARY SERVICE CONNECTIONS.

**2.0 SANITARY**

- ALL SANITARY SEWER MAINS TO BE CSA CERTIFIED, BELL AND SPIGOT TYPE. ONLY FACTORY FITTINGS TO BE USED. SEWER TO BE INSTALLED AS PER OSPD 1005.01. SANITARY SEWER MATERIALS TO BE 250mmØ AND SMALLER - PVC DR 35
- ALL SANITARY MAINTENANCE HOLES TO BE 1.2m DIAMETER AS PER CITY OF OTTAWA STANDARDS COMPLETE WITH BENCHING, RUNGS, FRAME AND COVER, DROP PIPES AND LANDINGS WHERE NEEDED.
- SANITARY MANHOLE COVERS TO BE CITY OF OTTAWA STD. S25 (MOD. OSPD. 401.020). SANITARY MANHOLE COVER TO BE CLOSED COVER TYPE, AS PER CITY STANDARD S24.
- SANITARY SEWER LEAKAGE TEST AND CCTV INSPECTION SHALL BE COMPLETED AS PER CITY SPECIFICATIONS PRIOR TO INSTALLATION OF BASE COURSE ASPHALT.
- ANY SANITARY SEWER WITH LESS THAN 2.0m COVER REQUIRES THERMAL INSULATION AS PER CITY OF OTTAWA STANDARD W22, OR AS APPROVED BY THE ENGINEER.
- CONNECTION TO THE EXISTING SANITARY SEWER TO BE INCLUDED IN THE COST FOR SANITARY SEWER INSTALLATION. THIS INCLUDES REINSTATEMENT OF ROAD CUTS TO CITY STANDARDS.
- ALL SANITARY CONNECTION TO INCLUDE BACKWATER VALVE TYPE 1 PER CITY STANDARD S14.1

**3.0 STORM**

- ALL STORM SEWERS TO BE CSA CERTIFIED, BELL AND SPIGOT TYPE. ALL STORM SEWERS TO BE INSTALLED PER MANUFACTURER'S INSTRUCTIONS. ONLY FACTORY FITTINGS TO BE USED. STORM SEWER MATERIALS TO BE 375mmØ AND SMALLER - PVC DR 35 - 450mmØ AND LARGER - 100-D REINFORCED CONCRETE. UNLESS NOTED OTHERWISE
- ALL STORM MAINTENANCE HOLES TO BE SIZED IN ACCORDANCE WITH THE PLANS AND AS PER CITY OF OTTAWA STANDARDS COMPLETE WITH BENCHING, RUNGS, AND FRAME AND COVER.
- STORM MH COVERS TO BE OPEN TYPE, AS PER CITY STANDARD S24. FRAMES TO BE PER CITY OF OTTAWA STD. S25. CONTRACTOR TO INSTALL FILTER FABRIC UNDER STORM MH COVER UNTIL SCODING IS COMPLETE.
- STORM MAINTENANCE HOLES TO BE OPSD, SIZE AS SPECIFIED, TAPER TOP.
- ALL CATCH BASINS TO BE AS PER OPSD 705.010, FRAME & FISH TYPE GRATE AS PER CITY OF OTTAWA STD. S19.1.
- ANY STORM SEWER WITH LESS THAN 2.0m COVER REQUIRES THERMAL INSULATION AS PER CITY OF OTTAWA STANDARD W22, OR AS APPROVED BY THE ENGINEER.
- CONNECTION TO THE EXISTING STORM SEWER TO BE INCLUDED IN THE COST FOR STORM SEWER INSTALLATION. THIS INCLUDES REINSTATEMENT OF ROAD CUT TO CITY STANDARDS.
- CONTRACTOR TO PROVIDE IPX-TEMPEST MHF ICDS SHOP DRAWINGS, OR EQUIVALENT. FOR ENGINEERS REVIEW PRIOR TO ORDERING ICDS.
- ALL STORM CONNECTION TO INCLUDE FOUNDATION BACKWATER VALVE TYPE 1 PER CITY STANDARD S14.
- LANDSCAPE SUBDRAIN AND APPURTENANCES TO BE INSTALLED PER CITY OF OTTAWA STANDARDS INCLUDING BUT NOT LIMITED TO S29, S30, S31
- WATER
- ALL WATERMANS 100mmØ OR GREATER TO BE PVC DR 18, LESS THAN 100mmØ TO BE COPPER OR APPROVED EQUAL WITH MINIMUM COVER OF 2.4m AND INSTALLED PER CITY OF OTTAWA STANDARDS. ALL DOMESTIC WATER SERVICES ARE TO BE 25mmØ.
- THRUUST BLOCKS TO BE INSTALLED AT ALL BENDS, TEES, AND CAPS ALL AS PER OPSD 1103.01 AND 1103.02.
- CONTRACTOR TO CONDUCT PRESSURE AND LEAKAGE TESTING OF ALL WATERMANS AND DISINFECT AND CHLORINATE ALL WATERMANS TO THE SATISFACTION OF M.O.E. AND THE CITY OF OTTAWA.
- TRACER WIRE TO BE INSTALLED ALONG THE FULL LENGTH OF WATERMAIN AND ATTACHED TO EACH MAIN STOP AS PER CITY OF OTTAWA STANDARDS.
- ALL COMPONENTS OF THE WATER DISTRIBUTION SYSTEM SHALL BE CATHODICALLY PROTECTED AS PER CITY OF OTTAWA STANDARDS.
- ALL VALVES & VALVE BOXES AND CHAMBERS, HYDRANTS, AND HYDRANT VALVES AND ASSEMBLIES SHALL BE INSTALLED AS PER CITY OF OTTAWA STANDARDS.
- ANY WATERMAIN WITH LESS THAN 2.4m COVER REQUIRES THERMAL INSULATION AS PER CITY OF OTTAWA STANDARD W22, OR AS APPROVED BY THE ENGINEER, OR IN CLOSE PROXIMITY TO OPEN STRUCTURES INSULATE PER W23.
- CONTRACTOR IS RESPONSIBLE FOR ACQUIRING THE WATER PERMIT FROM THE CITY OF OTTAWA AND PAYMENT OF ANY FEES ASSOCIATED WITH SECURING THE WATER PERMIT. OWNER IS RESPONSIBLE FOR REIMBURSING THE CONTRACTOR FOR THE ACTUAL COST OF ACQUIRING THE WATER PERMIT.
- CONNECTION TO EXISTING WATERMAIN TO BE INCLUDED IN THE COST FOR THE WATERMAIN INSTALLATION. THIS COST INCLUDES REINSTATEMENT OF ROAD CUTS TO CITY STANDARDS.
- ALL WATERMAIN CROSSINGS TO BE COMPLETED AS PER CITY OF OTTAWA STANDARDS W25 AND W25.2
- PARKING LOT AND WORK IN PUBLIC RIGHTS OF WAY
- CONTRACTOR TO REINSTATE ROAD CUTS PER CITY OF OTTAWA STANDARD R-10.
- CONTRACTOR SHALL PREPARE A TRAFFIC MANAGEMENT PLAN FOR REVIEW AND APPROVAL BY THE CITY OF OTTAWA. CONTRACTOR TO MAINTAIN TRAFFIC FLOW DURING THE ENTIRE CONSTRUCTION PERIOD. MAINTENANCE OF ROAD CUTS SHALL BE THE RESPONSIBILITY OF THE CONTRACTOR. PROVISION OF FLAGMEN, DETOURS AS NECESSARY, BARRICADES AND SIGNS TO THE FULL SATISFACTION OF THE ENGINEER AND ROAD AUTHORITY SHALL BE THE CONTRACTOR'S RESPONSIBILITY.
- CONTRACTOR TO PREPARE SUBGRADE, INCLUDING PROOFROLLING, TO THE SATISFACTION OF THE GEOTECHNICAL ENGINEER PRIOR TO THE COMMENCEMENT OF PLACEMENT OF GRANULAR B MATERIAL.
- FILL TO BE PLACED AND COMPACTED PER THE GEOTECHNICAL REPORT REQUIREMENTS.
- CONTRACTOR TO SUPPLY, PLACE AND COMPACT GRANULAR B MATERIAL IN ACCORDANCE WITH THE RECOMMENDATIONS OF THE GEOTECHNICAL ENGINEER. CONTRACTOR TO PROVIDE ENGINEER WITH SAMPLES OF GRANULAR B MATERIAL FOR TESTING AND CERTIFICATION FROM THE GEOTECHNICAL ENGINEER THAT THE MATERIAL MEETS THE GRADATION REQUIREMENTS SPECIFIED IN THE GEOTECHNICAL REPORT.
- GRANULAR A MATERIAL TO BE PLACED ONLY UPON APPROVAL BY THE GEOTECHNICAL ENGINEER OF GRANULAR B PLACEMENT.
- ASPHALT MATERIAL TO BE PLACED ONLY UPON APPROVAL BY THE GEOTECHNICAL ENGINEER OF GRANULAR A PLACEMENT.
- CONTRACTOR TO SUPPLY, PLACE AND COMPACT ASPHALT MATERIAL IN ACCORDANCE WITH THE RECOMMENDATIONS OF THE GEOTECHNICAL ENGINEER. CONTRACTOR TO PROVIDE ENGINEER WITH SAMPLES OF ASPHALT MATERIAL FOR TESTING AND CERTIFICATION FROM THE GEOTECHNICAL ENGINEER THAT THE MATERIAL MEETS THE REQUIREMENTS SPECIFIED IN THE GEOTECHNICAL REPORT.
- CONTRACTOR IS RESPONSIBLE FOR ESTABLISHING LINE AND GRADE IN ACCORDANCE WITH THE PLANS, AND FOR PROVIDING THE ENGINEER WITH VERIFICATION PRIOR TO PLACEMENT.
- PAVEMENT STRUCTURE (MATERIAL TYPES AND THICKNESSES) FOR HEAVY DUTY AND LIGHT DUTY AREAS TO BE AS SPECIFIED IN THE GEOTECHNICAL REPORT AND SHOWN ON THE PLANS.

CLIENT



2851 John Street, Suite One, Markham, Ontario L3R 5R7 T 905-968-3185

**COPYRIGHT**  
This drawing has been prepared solely for the intended use, thus any reproduction or distribution for any purpose other than authorized by IBI Group is forbidden. Written dimensions shall have precedence over scaled dimensions. Contractors shall verify and be responsible for all dimensions and conditions on the job, and IBI Group shall be informed of any variations from the dimension and conditions shown on the drawing. Shop drawings shall be submitted to IBI Group for general confirmation before proceeding with fabrication.

IBI Group Professional Services (Canada) Inc.  
is a member of the IBI Group of companies.

| ISSUES |                |            |
|--------|----------------|------------|
| No.    | DESCRIPTION    | DATE       |
| 1      | ISSUED FOR SPA | 2021-02-16 |
| 2      | SPA SUBMISSION | 2021       |

**NOT FOR CONSTRUCTION**

0 FOR NOTES, LEGEND



**CONSULTANTS**

Project Coordinator:  
North American Development Group

Architect:  
RLA Architecture

Surveyor:  
JD Halpenney & Assoc.

Geotechnical:  
Paterson Group

Traffic:  
JD Halpenney & Assoc.

Electrical:  
Hammerschlag & Joffe Inc.

Landscape:  
NAK Design Strategies

SEAL

**IBI GROUP**  
400 - 333 Preston Street  
Ottawa ON K1S 5M4 Canada  
tel 613 225 1311 fax 613 225 9868  
ibigroup.com

**PROJECT**  
21/35 HUNTMAR DRIVE

PROJECT NO:  
127134

DRAWN BY:  
EH

CHECKED BY:  
DGY

PROJECT MGR:  
DGY

APPROVED BY:  
DGY

**SHEET TITLE**  
GENERAL NOTES,  
LEGEND AND TABLES

SHEET NUMBER  
**C-010**

ISSUE  
**1**

**LEGEND:**

|          |                            |         |                            |
|----------|----------------------------|---------|----------------------------|
| ● MHS3A  | SANITARY MANHOLE STORM     | ■       | SURVEY MONUMENT FOUND      |
| ● MHST01 | MANHOLE                    | ▬       | STANDARD IRON BAR          |
| ● CB01   | CATCHBASIN                 | ▬▬      | SHORT STANDARD IRON BAR    |
| ● CBMH01 | CATCHBASIN MANHOLE         | IB      | IRON BAR                   |
| ● CBMH02 | CATCHBASIN MANHOLE C/W ICD | CP      | CONCRETE PIN               |
| ■ ECB01  | REAR YARD "END" CATCHBASIN | IIA     | DIAMETER                   |
| -----    | SUBDRAIN                   | BLK     | BLOCK                      |
| -----    | 200mmØ SAN                 | PIN     | PROPERTY IDENTIFIER NUMBER |
| -----    | 300mmØ STM                 | CB      | CATCH BASIN                |
| ● VB     | VALVE AND VALVE BOX        | ○ MH    | MANHOLE                    |
| -----    | 200Ø WATERMAIN             | ○ MHST  | STORM MANHOLE              |
| -----    | VERTICAL BEND LOCATION     | ○ MHS3A | SANITARY MANHOLE           |
| (M)      | METER                      | ○ WMH   | WATER MANHOLE              |
| (RM)     | REMOTE METER               | ○ TMH   | TRAFFIC MANHOLE            |
| (2R)     | NUMBER OF RISERS           | ○ HMH   | HYDRO MANHOLE              |
|          |                            | ○ FH    | FIRE HYDRANT               |
|          |                            | ▬ TCB   | TRAFFIC CONTROL BOX        |
|          |                            | ▬ W/V   | WATER VALVE                |
|          |                            | ⊗ TL    | TRAFFIC LIGHT              |
|          |                            | ● LS    | LAMP STANDARD              |
|          |                            | ○ UP    | UTILITY POLE               |
|          |                            | ▬ BP    | BELL PEDESTAL              |
|          |                            | ○ MW    | MONITORING WELL            |
|          |                            | ○       | BOREHOLE                   |
|          |                            | ●       | BOLLARD                    |
|          |                            | —       | GUY WIRE AND ANCHOR        |
|          |                            | —       | SIGN                       |
|          |                            | ○       | DECIDUOUS TREE             |
|          |                            | —       | GASMAIN                    |
|          |                            | —       | SANITARY SEWER             |
|          |                            | —       | STORM SEWER                |
|          |                            | —       | WATERMAIN                  |
|          |                            | —       | UNDERGROUND BELL           |
|          |                            | —       | UNDERGROUND HYDRO          |
|          |                            | —       | STREET LIGHTING            |
|          |                            | —       | ROGERS CABLE               |
|          |                            | —       | TRAFFIC                    |
|          |                            | —       | EDGE OF TREES              |

**FAIRHALL, MOFFATT AND WOODLAND LTD. TOPOGRAPHIC LEGEND**

| STORM STRUCTURE TABLE |           |            |                   |            |                    |                    |
|-----------------------|-----------|------------|-------------------|------------|--------------------|--------------------|
| NAME                  | RIM ELEV. | INVERT IN  | INVERT IN ASBUILT | INVERT OUT | INVERT OUT ASBUILT | DESCRIPTION        |
| MHST01                | 102.66    | W100.961   |                   |            | 99.974             | 1200Ø OPSD 701.010 |
|                       |           | W100.540   |                   |            |                    |                    |
|                       |           | SW 100 C88 |                   |            |                    |                    |
| CBMH02                | 102.53    | 101.164    |                   | 101.014    |                    | 1200Ø OPSD 701.010 |
| CBMH03                | 102.64    | 101.300    |                   | 101.240    |                    | 1200Ø OPSD 701.010 |
| CBMH04                | 102.80    | 101.400    |                   | 101.380    |                    | 1200Ø OPSD 701.010 |
| CBMH05                | 102.85    | 101.540    |                   | 101.520    |                    | 1200Ø OPSD 701.010 |
| CBMH06                | 102.92    | 101.700    |                   | 101.590    |                    | 1200Ø OPSD 701.010 |

| WATERMAIN SCHEDULE |                          |                |                  |                    |  |
|--------------------|--------------------------|----------------|------------------|--------------------|--|
| Station            | Description              | Finished Grade | Top of Watermain | As Built Watermain |  |
| A                  | 0+000.00 TEE 400mmX200mm | 102.91         | 100.51           |                    |  |
|                    | 0+001.10 VB 200mm        | 102.90         | 100.50           |                    |  |
|                    | 0+004.06 V-BEND 200mm    | 102.94         | 100.54           |                    |  |
|                    | 0+004.36 V-BEND 200mm    | 102.94         | 101.08           |                    |  |
|                    | 0+009.71 V-BEND 200mm    | 102.84         | 101.50           |                    |  |
|                    | 0+010.01 V-BEND 200mm    | 102.84         | 100.44           |                    |  |
|                    | 0+019.83 VB 200mm        | 103.04         | 100.64           |                    |  |
|                    | 0+022.17 CAP 200mm       | 103.05         | 100.85           |                    |  |
| B                  |                          |                |                  |                    |  |
| C                  | 0+000.00 TEE 400mmX200mm | 103.08         | 100.68           |                    |  |
|                    | 0+001.10 VB 200mm        | 103.13         | 100.73           |                    |  |
|                    | 0+003.79 V-BEND 200mm    | 103.24         | 100.84           |                    |  |
|                    | 0+004.09 V-BEND 200mm    | 103.28         | 101.14           |                    |  |
|                    | 0+008.75 V-BEND 200mm    | 103.11         | 101.14           |                    |  |
|                    | 0+007.05 V-BEND 200mm    | 103.07         | 100.20           |                    |  |
|                    | 0+008.71 V-BEND 200mm    | 102.95         | 100.20           |                    |  |
|                    | 0+010.01 V-BEND 200mm    | 102.94         | 100.54           |                    |  |
|                    | 0+019.83 VB 200mm        | 103.13         | 100.73           |                    |  |
|                    | 0+022.17 CAP 200mm       | 103.01         | 100.61           |                    |  |
| D                  |                          |                |                  |                    |  |

CITY FILE No. D07-12-21-0035  
Last Saved: June 30, 2021, by Eberne  
Plotted: Monday, July 5, 2021, 1:20:56 PM by Eric Henne  
Scale: CHECK

# **APPENDIX C**

- C-400 Sanitary Tributary Area Plan
- Sanitary sewer design sheet



**IBI GROUP**  
 400-333 Preston Street  
 Ottawa, Ontario K1S 5N4 Canada  
 tel 613 225 1311 fax 613 225 9868  
 ibigroup.com

**SANITARY SEWER DESIGN SHEET**

21 Huntmar Rd  
 CITY OF OTTAWA  
 North American Group

| LOCATION             |         |           |       | RESIDENTIAL        |            |     |    |                     |            | ICI AREAS |                 |                 |               |      |           | INFILTRATION ALLOWANCE |            |      | FIXED FLOW (L/s) |                 | TOTAL FLOW (L/s) | PROPOSED SEWER DESIGN |            |      |      |       |       |                  |                |            |          |           |                       |                    |     |
|----------------------|---------|-----------|-------|--------------------|------------|-----|----|---------------------|------------|-----------|-----------------|-----------------|---------------|------|-----------|------------------------|------------|------|------------------|-----------------|------------------|-----------------------|------------|------|------|-------|-------|------------------|----------------|------------|----------|-----------|-----------------------|--------------------|-----|
| STREET               | AREA ID | FROM MH   | TO MH | AREA w/ Units (Ha) | UNIT TYPES |     |    | AREA w/o Units (Ha) | POPULATION |           | RES PEAK FACTOR | PEAK FLOW (L/s) | INSTITUTIONAL |      | AREA (Ha) |                        | INDUSTRIAL |      | ICI PEAK FACTOR  | PEAK FLOW (L/s) | AREA (Ha)        |                       | FLOW (L/s) | IND  | CUM  | IND   | CUM   | TOTAL FLOW (L/s) | CAPACITY (L/s) | LENGTH (m) | DIA (mm) | SLOPE (%) | VELOCITY (full) (m/s) | AVAILABLE CAPACITY |     |
|                      |         |           |       |                    | 1B         | 2B  | 3B |                     | APT        | IND       |                 |                 | CUM           | IND  | CUM       | IND                    | CUM        | IND  |                  |                 | CUM              | IND                   |            |      |      |       |       |                  |                |            |          |           |                       | CUM                | L/s |
| OUTLET TO HUNTMAR RD |         |           |       |                    |            |     |    |                     |            |           |                 |                 |               |      |           |                        |            |      |                  |                 |                  |                       |            |      |      |       |       |                  |                |            |          |           |                       |                    |     |
|                      | 1       | BLDG A& B | 2     | 1.96               | 149        | 195 |    | 618.1               | 618.1      | 3.34      | 6.69            | 0.00            | 0.00          | 0.00 | 0.00      | 0.00                   | 0.00       | 0.00 | 1.00             | 0.00            | 1.56             | 1.6                   | 0.51       | 0.00 | 0.00 | 7.21  | 87.74 | 1.64             | 250            | 2.00       | 1.731    | 80.53     | 91.79%                |                    |     |
|                      |         | 2         | 1     |                    |            |     |    | 0.0                 | 618.1      | 3.34      | 6.69            | 0.00            | 0.00          | 0.00 | 0.00      | 0.00                   | 0.00       | 1.00 | 0.00             | 0.00            | 1.6              | 0.51                  | 0.00       | 0.00 | 7.21 | 87.74 | 18.22 | 250              | 2.00           | 1.731      | 80.53    | 91.79%    |                       |                    |     |
|                      |         |           |       | 1.56               | 149        | 0   |    | 618.1               |            |           |                 |                 |               |      |           |                        |            |      |                  |                 |                  |                       |            |      |      |       |       |                  |                |            |          |           |                       |                    |     |

|   |  |                        |                        |                                    |                  |
|---|--|------------------------|------------------------|------------------------------------|------------------|
| <b>Design Parameters:</b>                   | <b>Notes:</b>  | <b>Designed:</b>       | <b>No.</b>             | <b>Revision</b>                    | <b>Date</b>      |
| Residential                                 | 1. Mannings coefficient (n) = 0.013  | R.M.                   | 1.                     | Servicing Brief - Submission No. 1 | 2021-02-04       |
| ICI Areas                                   | 2. Demand (per capita): 280 L/day  | <b>Checked:</b>        |                        |                                    |                  |
| 3B 2.8 p/p/u                                | 3. Infiltration allowance: 0.33 L/s/ha   | D.G.Y.                 |                        |                                    |                  |
| 2B 2.1 p/p/u INST 28,000 L/ha/day           | 4. Residential Peaking Factor: Harmon Formula = $1 + (14/(4 + (P/1000)^{0.5})) \cdot 0.8$                |                        |                        |                                    |                  |
| 1B 1.4 p/p/u COM 28,000 L/ha/day            | where K = 0.8 Correction Factor  | <b>Dwg. Reference:</b> |                        |                                    |                  |
| APT 1.8 p/p/u IND 35,000 L/ha/day MOE Chart | 5. Commercial and Institutional Peak Factors based on total area, 1.5 if greater than 20%, otherwise 1.0 | 127134-400             | <b>File Reference:</b> | <b>Date:</b>                       | <b>Sheet No:</b> |
| Other 60 p/p/ha 17000 L/ha/day              |  |                        | 127134.6.4.4           | 2021-02-04                         | 1 of 1           |



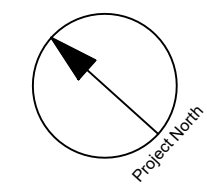

**COPYRIGHT**  
This drawing has been prepared solely for the intended use. Any reproduction or distribution for any purpose other than authorized by IBI Group is forbidden. Written dimensions shall have precedence over scaled dimensions. Contractors shall verify and be responsible for all dimensions and conditions on the job, and IBI Group shall be informed of any variations from the dimensions and conditions shown on the drawing. Shop drawings shall be submitted to IBI Group for general concurrence before proceeding with fabrication.

**IBI Group Professional Services (Canada) Inc.**  
is a member of the IBI Group of companies.

**ISSUES**

| No. | DESCRIPTION    | DATE       |
|-----|----------------|------------|
| 1   | ISSUED FOR SPA | 2021-02-16 |
| 2   | SPA SUBMISSION | 2021       |

**NOT FOR CONSTRUCTION**

0 FOR NOTES, LEGEND



**CONSULTANTS**

Project Coordinator:  
North American Development Group

Architect:  
RLA Architecture

Surveyor:  
Fairhall, Moffatt and Woodland Ltd.

Geotechnical:  
Paterson Group

Traffic:  
JD Halpenny & Assoc.

Electrical:  
Hammerslag & Joffe Inc.

Landscape:  
NAK Design Strategies

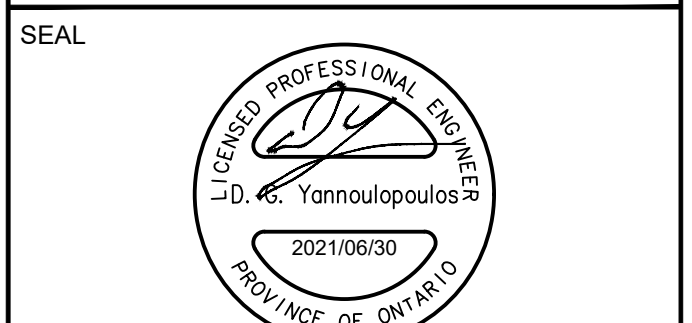
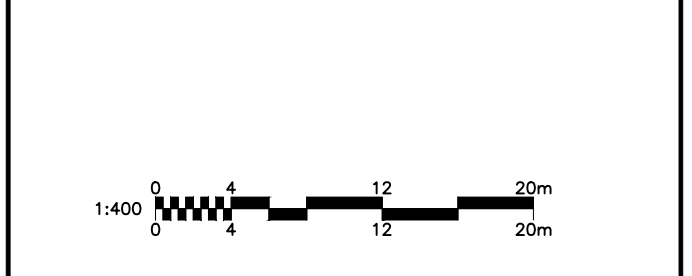

**IBI GROUP**  
Suite 400 - 333 Preston Street  
Ottawa ON K1S 5N4 Canada  
tel 613 225 1311 / 613 241 3300 fax 613 225 9868  
ibigroup.com

**PROJECT**  
21/35 HUNTMAR DRIVE

**PROJECT NO:**  
127134

**DRAWN BY:** EH

**PROJECT MGR:** DGY

**CHECKED BY:** DGY

**APPROVED BY:** DGY

**SHEET TITLE**  
SANITARY DRAINAGE PLAN

**SHEET NUMBER**  
C-400

**ISSUE**  
1

CITY PLAN No. 18424

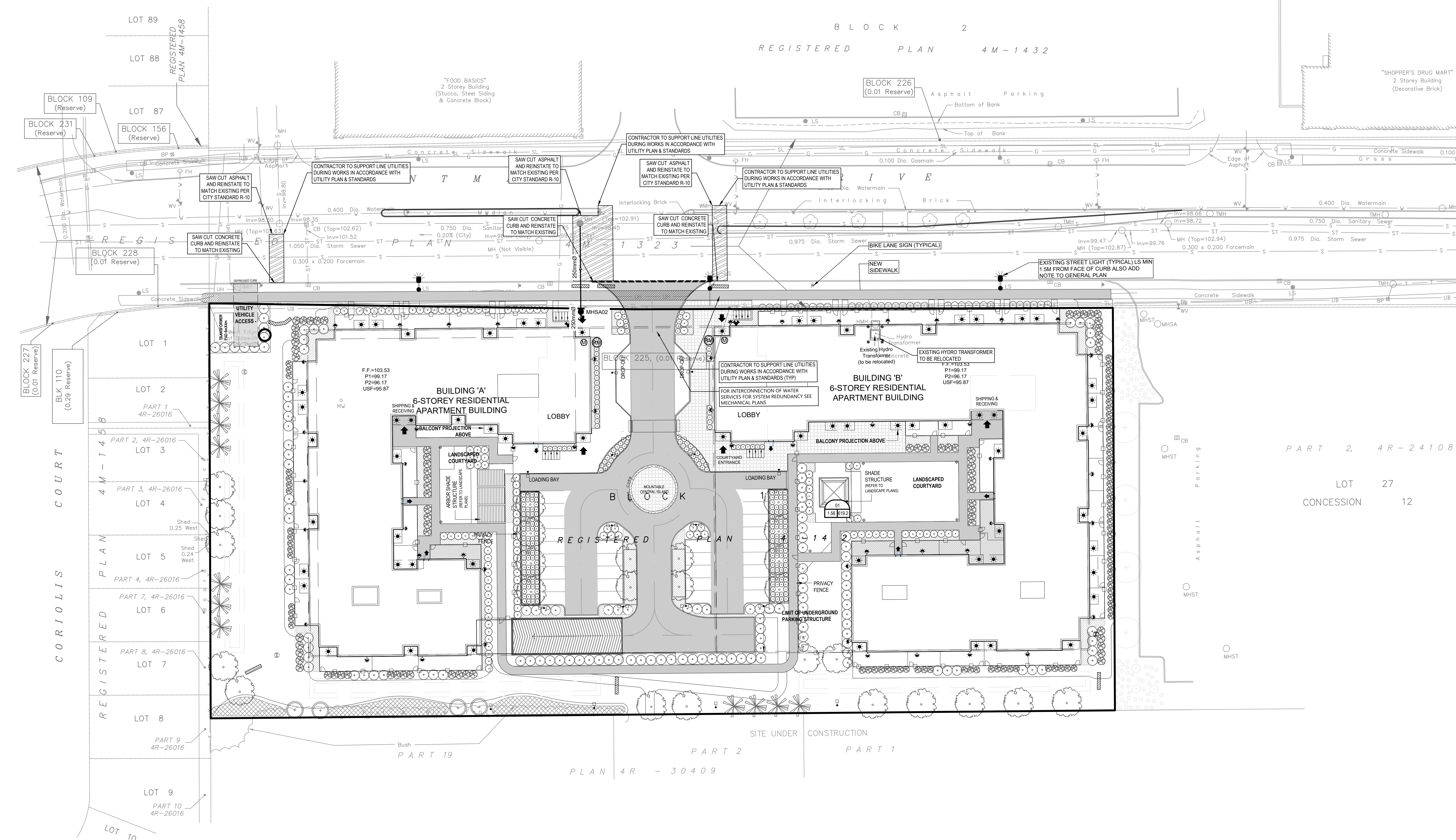

**LEGEND :**

|              |                  |
|--------------|------------------|
| 01           | AREA NUMBER      |
| 1.56   619.2 | POPULATION       |
|              | AREA IN HECTARES |

CITY FILE No. D07-12-21-0035  
File Location: J:\127134\_21\_huntmar\7\_0\_Production\02\_Design\04\_Civil\Sheets\C-400.dwg Last Saved: June 30, 2021, by: Ehenne Printed: Monday, July 5, 2021 1:12:32 PM by: Eric Henne



# **APPENDIX D**

- C-500 Storm Tributary Area Plan
- Storm sewer design sheets
- Modified Rational Method design sheets





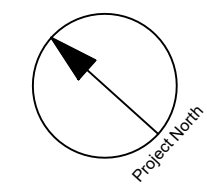

**COPYRIGHT**  
This drawing has been prepared solely for the intended use, and any reproduction or distribution for any purpose other than that authorized by IBI Group is forbidden. Written dimensions shall have precedence over scaled dimensions. Contractors shall verify and be responsible for all dimensions and conditions on the job, and IBI Group shall be informed of any variations from the dimensions and conditions shown on the drawing. Shop drawings shall be submitted to IBI Group for general concurrence before proceeding with fabrication.

**IBI Group Professional Services (Canada) Inc.**  
is a member of the IBI Group of companies.

| ISSUES | No. | DESCRIPTION    | DATE       |
|--------|-----|----------------|------------|
|        | 1   | ISSUED FOR SPA | 2021-02-16 |
|        | 2   | SPA SUBMISSION | 2021       |

**NOT FOR CONSTRUCTION**

0 FOR NOTES, LEGEND



**CONSULTANTS**

Project Coordinator:  
North American Development Group

Architect:  
RLA Architecture

Surveyor:  
Fairhall, Moffatt and Woodland Ltd.

Geotechnical:  
Paterson Group

Traffic:  
JD Halpenney & Assoc.

Electrical:  
Hammerslag & Joffe Inc.

Landscape:  
NAK Design Strategies

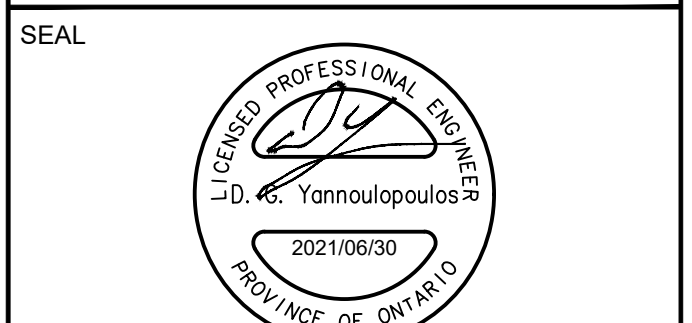
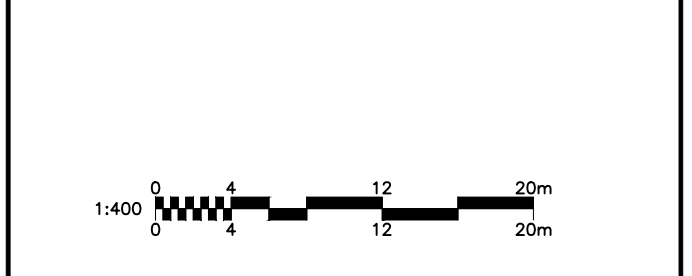

**IBI GROUP**  
Suite 400 - 333 Preston Street  
Ottawa ON K1S 5N4 Canada  
tel 613 225 1311 / 613 241 3300 fax 613 225 9868  
ibigroup.com

**PROJECT**  
21/35 HUNTMAR DRIVE

**PROJECT NO:**  
127134

**DRAWN BY:** EH

**PROJECT MGR:** DGY

**CHECKED BY:** DGY

**APPROVED BY:** DGY

**SHEET TITLE**  
STORM DRAINAGE PLAN

**SHEET NUMBER** C-500

**ISSUE** 1

CITY PLAN No. 18424

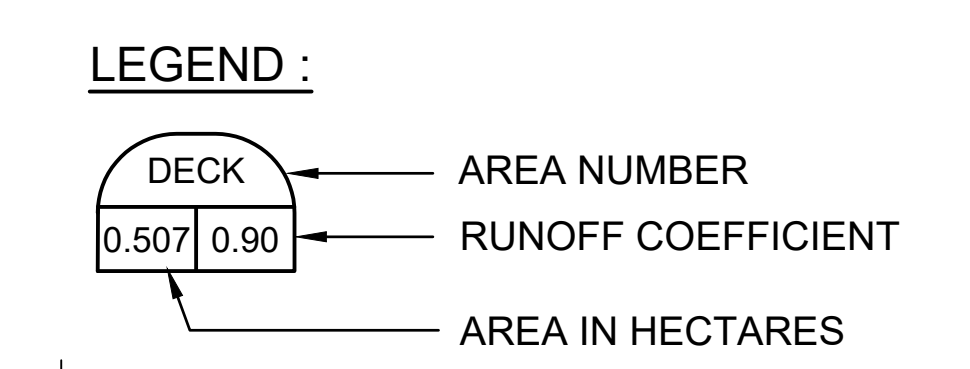
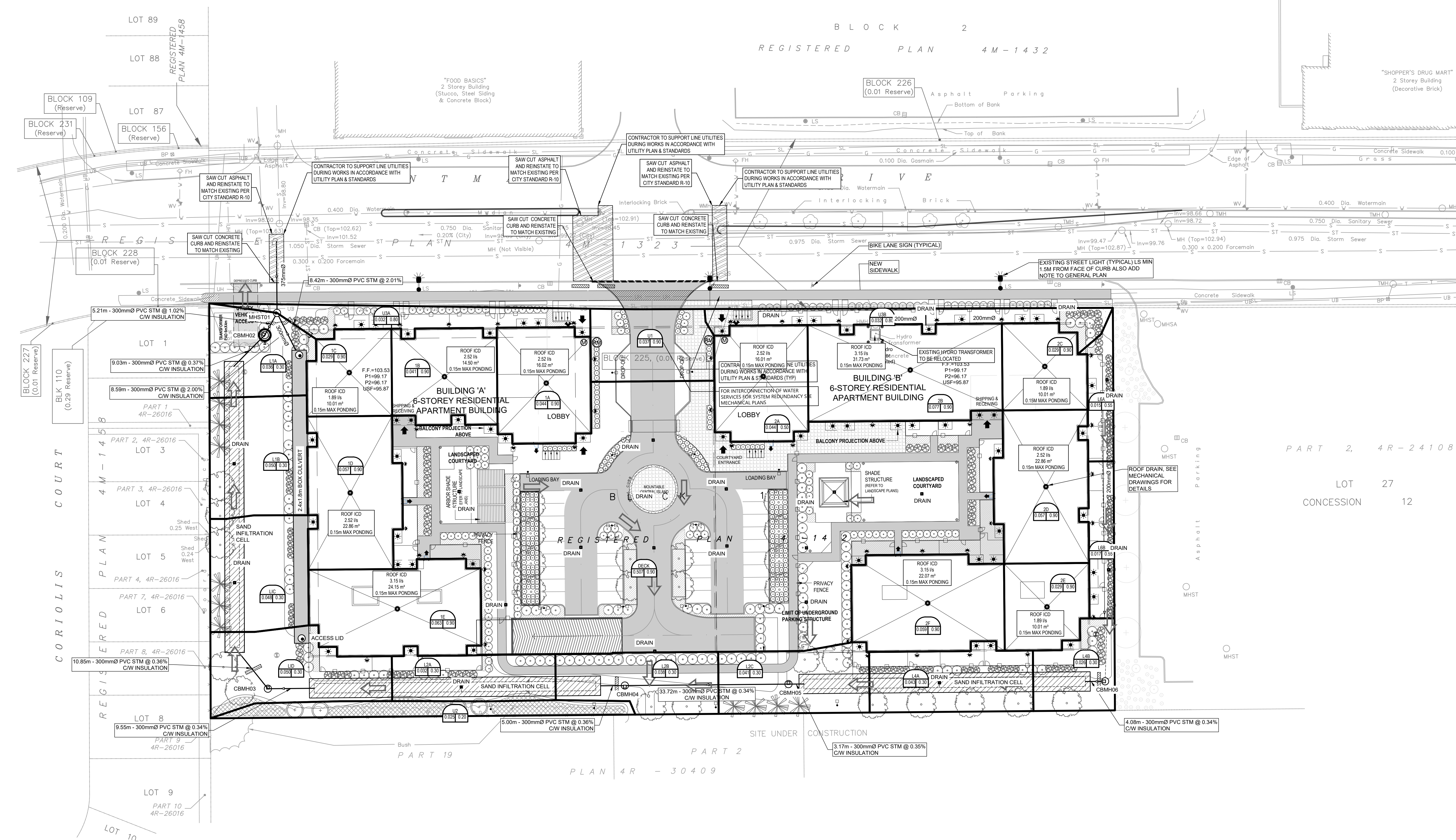

CITY FILE No. D07-12-21-0035  
File Location: \\127134\_21\_huntmar\7\_0\_Production\02\_Design\04\_Civil\Sheets\C-500.dwg Last Saved: July 5, 2021, 1:21:50 PM by Eric Henrie





IBI GROUP  
400-333 Preston Street  
Ottawa, Ontario K1S 5N4 Canada  
tel 613 225 1311 fax 613 225 9868  
ibigroup.com

PROJECT: 21 HUNTMAR RD  
DATE: 2021-06-29  
FILE: 127134-6.4  
REV #: 2  
DESIGNED BY: R.M.  
CHECKED BY: D.G.Y.

## STORMWATER MANAGEMENT

### Maximum Allowable Release Rate

Restricted Flowrate (based on 85l/s/Ha)

$$A_{site} = 1.562 \text{ Ha}$$

$$Q_{restricted} = 132.74 \text{ L/s}$$

| unrestricted flow to boulevards | Area (Ha) | C (C*1.25) | 100yr   | 5yr     |
|---------------------------------|-----------|------------|---------|---------|
|                                 |           |            | Q (l/s) | Q (l/s) |
| area 1                          | 0.0370    | 1          | 18.37   | 8.49    |
| area 2                          | 0.0250    | 0.25       | 3.10    | 1.43    |
| Area 3                          | 0.0640    | 1          | 31.77   | 14.68   |
|                                 | 0.1260    |            | 53.24   | 24.60   |

$$i_{100yr} = 1:100 \text{ year Intensity} = 1735.688 / (T_c + 6.014)^{0.820} \quad t_c = 10$$

Maximum Allowable Release Rate ( $Q_{max\ allowable} = Q_{restricted} - Q_{uncontrolled}$ )

$$Q_{max\ allowable} = 79.50 \text{ L/s}$$

### Formulas and Descriptions

$$i_{2yr} = 1:2 \text{ year Intensity} = 732.951 / (T_c + 6.199)^{0.810}$$

$$i_{5yr} = 1:5 \text{ year Intensity} = 998.071 / (T_c + 6.053)^{0.814}$$

$$i_{100yr} = 1:100 \text{ year Intensity} = 1735.688 / (T_c + 6.014)^{0.820}$$

$T_c$  = Time of Concentration (min)

C = Average Runoff Coefficient

A = Area (Ha)

Q = Flow =  $2.78CiA$  (L/s)

### MODIFIED RATIONAL METHOD (100-Year, 5-Year & 2-Year Ponding)

| Drainage Area        |                       | Roof Area 1A                             |             |                   |                        |
|----------------------|-----------------------|--|-------------|-------------------|------------------------|
| Area (Ha)            |                       | 0.044                                    |             |                   |                        |
| C =                  | 1.00                  | Restricted Flow $Q_r$ (L/s) = 2.520      |             |                   |                        |
| 100-Year Ponding     |                       |  |             |                   |                        |
| $T_c$ Variable (min) | $i_{100yr}$ (mm/hour) | Peak Flow $Q_p = 2.78xCi_{100yr}A$ (L/s) | $Q_r$ (L/s) | $Q_p - Q_r$ (L/s) | Volume 100yr ( $m^3$ ) |
| 33                   | 86.03                 | 10.52                                    | 2.52        | 8.00              | 15.85                  |
| 38                   | 77.93                 | 9.53                                     | 2.52        | 7.01              | 15.99                  |
| 43                   | 71.35                 | 8.73                                     | 2.52        | 6.21              | 16.02                  |
| 48                   | 65.89                 | 8.06                                     | 2.52        | 5.54              | 15.95                  |
| 58                   | 57.32                 | 7.01                                     | 2.52        | 4.49              | 15.63                  |

| Storage ( $m^3$ ) |          |         |             |         |
|-------------------|----------|---------|-------------|---------|
| Overflow          | Required | Surface | Sub-surface | Balance |
| 0.00              | 16.02    | 17.60   | 0           | 0.00    |

| Drainage Area        |                     | Roof Area 1A                           |             |                   |                      |
|----------------------|---------------------|--|-------------|-------------------|----------------------|
| Area (Ha)            |                     | 0.044                                  |             |                   |                      |
| C =                  | 0.90                | Restricted Flow $Q_r$ (L/s) = 2.520    |             |                   |                      |
| 5-Year Ponding       |                     |  |             |                   |                      |
| $T_c$ Variable (min) | $i_{5yr}$ (mm/hour) | Peak Flow $Q_p = 2.78xCi_{5yr}A$ (L/s) | $Q_r$ (L/s) | $Q_p - Q_r$ (L/s) | Volume 5yr ( $m^3$ ) |
| 11                   | 99.19               | 10.92                                  | 2.52        | 8.40              | 5.54                 |
| 16                   | 80.46               | 8.86                                   | 2.52        | 6.34              | 6.08                 |
| 21                   | 68.13               | 7.50                                   | 2.52        | 4.98              | 6.28                 |
| 26                   | 59.35               | 6.53                                   | 2.52        | 4.01              | 6.26                 |
| 31                   | 52.74               | 5.81                                   | 2.52        | 3.29              | 6.11                 |

| Storage ( $m^3$ ) |          |         |             |         |
|-------------------|----------|---------|-------------|---------|
| Overflow          | Required | Surface | Sub-surface | Balance |
| 0.00              | 6.28     | 17.60   | 0           | 0.00    |

| Drainage Area        |                     | Roof Area 1A                           |             |                   |                      |
|----------------------|---------------------|--|-------------|-------------------|----------------------|
| Area (Ha)            |                     | 0.044                                  |             |                   |                      |
| C =                  | 0.90                | Restricted Flow $Q_r$ (L/s) = 2.520    |             |                   |                      |
| 2-Year Ponding       |                     |  |             |                   |                      |
| $T_c$ Variable (min) | $i_{2yr}$ (mm/hour) | Peak Flow $Q_p = 2.78xCi_{2yr}A$ (L/s) | $Q_r$ (L/s) | $Q_p - Q_r$ (L/s) | Volume 2yr ( $m^3$ ) |
| 8                    | 85.46               | 9.41                                   | 2.52        | 6.89              | 3.31                 |
| 13                   | 66.93               | 7.37                                   | 2.52        | 4.85              | 3.78                 |
| 18                   | 55.49               | 6.11                                   | 2.52        | 3.59              | 3.88                 |
| 23                   | 47.66               | 5.25                                   | 2.52        | 2.73              | 3.76                 |
| 33                   | 37.54               | 4.13                                   | 2.52        | 1.61              | 3.19                 |

| Storage ( $m^3$ ) |          |         |             |         |
|-------------------|----------|---------|-------------|---------|
| Overflow          | Required | Surface | Sub-surface | Balance |
| 0.00              | 3.88     | 17.60   | 0           | 0.00    |

| Drainage Area | Roof Area 1B |
|---------------|--------------|
| Area (Ha)     | 0.041        |

| Drainage Area | Roof Area 1B |
|---------------|--------------|
| Area (Ha)     | 0.041        |

| Drainage Area | Roof Area 1B |
|---------------|--------------|
| Area (Ha)     | 0.041        |



| C =                  | 1.00                  | Restricted Flow $Q_r$ (L/s)=                                  |             |                   |                        | 2.520 |
|----------------------|-----------------------|---|-------------|-------------------|------------------------|-------|
| 100-Year Ponding     |                       |   |             |                   |                        |       |
| $T_c$ Variable (min) | $i_{100yr}$ (mm/hour) | Peak Flow $Q_p = 2.78 \times C_i \times 100yr \times A$ (L/s) | $Q_r$ (L/s) | $Q_p - Q_r$ (L/s) | Volume 100yr ( $m^3$ ) |       |
| 31                   | 89.83                 | 10.24   | 2.52        | 7.72              | 14.36                  |       |
| 36                   | 80.96                 | 9.23  | 2.52        | 6.71              | 14.49                  |       |
| 41                   | 73.83                 | 8.42  | 2.52        | 5.90              | 14.50                  |       |
| 46                   | 67.96                 | 7.75  | 2.52        | 5.23              | 14.42                  |       |
| 56                   | 58.83                 | 6.71  | 2.52        | 4.19              | 14.06                  |       |

| Storage ( $m^3$ ) |          |         |             |         |
|-------------------|----------|---------|-------------|---------|
| Overflow          | Required | Surface | Sub-surface | Balance |
| 0.00              | 14.50    | 16.40   | 0           | 0.00    |

| C =                  | 0.90                | Restricted Flow $Q_r$ (L/s)=                                |             |                   |                      | 2.520 |
|----------------------|---------------------|---|-------------|-------------------|----------------------|-------|
| 5-Year Ponding       |                     |   |             |                   |                      |       |
| $T_c$ Variable (min) | $i_{5yr}$ (mm/hour) | Peak Flow $Q_p = 2.78 \times C_i \times 5yr \times A$ (L/s) | $Q_r$ (L/s) | $Q_p - Q_r$ (L/s) | Volume 5yr ( $m^3$ ) |       |
| 14                   | 86.93               | 8.92  | 2.52        | 6.40              | 5.37                 |       |
| 19                   | 72.53               | 7.44  | 2.52        | 4.92              | 5.61                 |       |
| 24                   | 62.54               | 6.42  | 2.52        | 3.90              | 5.61                 |       |
| 29                   | 55.18               | 5.66  | 2.52        | 3.14              | 5.46                 |       |
| 34                   | 49.50               | 5.08  | 2.52        | 2.56              | 5.22                 |       |

| Storage ( $m^3$ ) |          |         |             |         |
|-------------------|----------|---------|-------------|---------|
| Overflow          | Required | Surface | Sub-surface | Balance |
| 0.00              | 5.61     | 16.40   | 0           | 0.00    |

| C =                  | 0.90                | Restricted Flow $Q_r$ (L/s)=                                |             |                   |                      | 2.520 |
|----------------------|---------------------|---|-------------|-------------------|----------------------|-------|
| 2-Year Ponding       |                     |   |             |                   |                      |       |
| $T_c$ Variable (min) | $i_{2yr}$ (mm/hour) | Peak Flow $Q_p = 2.78 \times C_i \times 2yr \times A$ (L/s) | $Q_r$ (L/s) | $Q_p - Q_r$ (L/s) | Volume 2yr ( $m^3$ ) |       |
| 8                    | 85.46               | 8.77  | 2.52        | 6.25              | 3.00                 |       |
| 13                   | 66.93               | 6.87  | 2.52        | 4.35              | 3.39                 |       |
| 18                   | 55.49               | 5.69  | 2.52        | 3.17              | 3.43                 |       |
| 23                   | 47.66               | 4.89  | 2.52        | 2.37              | 3.27                 |       |
| 33                   | 37.54               | 3.85  | 2.52        | 1.33              | 2.64                 |       |

| Storage ( $m^3$ ) |          |         |             |         |
|-------------------|----------|---------|-------------|---------|
| Overflow          | Required | Surface | Sub-surface | Balance |
| 0.00              | 3.43     | 16.40   | 0           | 0.00    |

| Drainage Area                | Roof Area 1C          |   |             |                   |                        |
|------------------------------|-----------------------|---|-------------|-------------------|------------------------|
| Area (Ha)                    | 0.029                 |   |             |                   |                        |
| C =                          | 1.00                  |   |             |                   |                        |
| Restricted Flow $Q_r$ (L/s)= |                       | 1.890   |             |                   |                        |
| 100-Year Ponding             |                       |   |             |                   |                        |
| $T_c$ Variable (min)         | $i_{100yr}$ (mm/hour) | Peak Flow $Q_p = 2.78 \times C_i \times 100yr \times A$ (L/s) | $Q_r$ (L/s) | $Q_p - Q_r$ (L/s) | Volume 100yr ( $m^3$ ) |
| 25                           | 103.85                | 8.37  | 1.89        | 6.48              | 9.72                   |
| 30                           | 91.87                 | 7.41  | 1.89        | 5.52              | 9.93                   |
| 35                           | 82.58                 | 6.66  | 1.89        | 4.77              | 10.01                  |
| 40                           | 75.15                 | 6.06  | 1.89        | 4.17              | 10.00                  |
| 50                           | 63.95                 | 5.16  | 1.89        | 3.27              | 9.80                   |

| Storage ( $m^3$ ) |          |         |             |         |
|-------------------|----------|---------|-------------|---------|
| Overflow          | Required | Surface | Sub-surface | Balance |
| 0.00              | 10.01    | 11.60   | 0           | 0.00    |

| Drainage Area                | Roof Area 1C        |   |             |                   |                      |
|------------------------------|---------------------|---|-------------|-------------------|----------------------|
| Area (Ha)                    | 0.029               |   |             |                   |                      |
| C =                          | 0.90                |   |             |                   |                      |
| Restricted Flow $Q_r$ (L/s)= |                     | 1.890   |             |                   |                      |
| 5-Year Ponding               |                     |   |             |                   |                      |
| $T_c$ Variable (min)         | $i_{5yr}$ (mm/hour) | Peak Flow $Q_p = 2.78 \times C_i \times 5yr \times A$ (L/s) | $Q_r$ (L/s) | $Q_p - Q_r$ (L/s) | Volume 5yr ( $m^3$ ) |
| 10                           | 104.19              | 7.56  | 1.89        | 5.67              | 3.40                 |
| 15                           | 83.56               | 6.06  | 1.89        | 4.17              | 3.76                 |
| 20                           | 70.25               | 5.10  | 1.89        | 3.21              | 3.85                 |
| 25                           | 60.90               | 4.42  | 1.89        | 2.53              | 3.79                 |
| 30                           | 53.93               | 3.91  | 1.89        | 2.02              | 3.64                 |

| Storage ( $m^3$ ) |          |         |             |         |
|-------------------|----------|---------|-------------|---------|
| Overflow          | Required | Surface | Sub-surface | Balance |
| 0.00              | 3.85     | 11.60   | 0           | 0.00    |

| Drainage Area                | Roof Area 1C        |   |             |                   |                      |
|------------------------------|---------------------|---|-------------|-------------------|----------------------|
| Area (Ha)                    | 0.029               |   |             |                   |                      |
| C =                          | 0.90                |   |             |                   |                      |
| Restricted Flow $Q_r$ (L/s)= |                     | 1.890   |             |                   |                      |
| 2-Year Ponding               |                     |   |             |                   |                      |
| $T_c$ Variable (min)         | $i_{2yr}$ (mm/hour) | Peak Flow $Q_p = 2.78 \times C_i \times 2yr \times A$ (L/s) | $Q_r$ (L/s) | $Q_p - Q_r$ (L/s) | Volume 2yr ( $m^3$ ) |
| 6                            | 96.64               | 7.01  | 1.89        | 5.12              | 1.84                 |
| 11                           | 73.17               | 5.31  | 1.89        | 3.42              | 2.26                 |
| 16                           | 59.50               | 4.32  | 1.89        | 2.43              | 2.33                 |
| 21                           | 50.48               | 3.66  | 1.89        | 1.77              | 2.23                 |
| 31                           | 39.17               | 2.84  | 1.89        | 0.95              | 1.77                 |

| Storage ( $m^3$ ) |          |         |             |         |
|-------------------|----------|---------|-------------|---------|
| Overflow          | Required | Surface | Sub-surface | Balance |
| 0.00              | 2.33     | 11.60   | 0           | 0.00    |

| Drainage Area                | 1D                    |   |             |                   |                        |
|------------------------------|-----------------------|---|-------------|-------------------|------------------------|
| Area (Ha)                    | 0.057                 |   |             |                   |                        |
| C =                          | 1.00                  |   |             |                   |                        |
| Restricted Flow $Q_r$ (L/s)= |                       | 2.520   |             |                   |                        |
| 100-Year Ponding             |                       |   |             |                   |                        |
| $T_c$ Variable (min)         | $i_{100yr}$ (mm/hour) | Peak Flow $Q_p = 2.78 \times C_i \times 100yr \times A$ (L/s) | $Q_r$ (L/s) | $Q_p - Q_r$ (L/s) | Volume 100yr ( $m^3$ ) |
| 43                           | 71.35                 | 11.31   | 2.52        | 8.79              | 22.67                  |
| 48                           | 65.89                 | 10.44   | 2.52        | 7.92              | 22.81                  |
| 53                           | 61.28                 | 9.71  | 2.52        | 7.19              | 22.86                  |
| 58                           | 57.32                 | 9.08  | 2.52        | 6.56              | 22.84                  |
| 68                           | 50.89                 | 8.06  | 2.52        | 5.54              | 22.62                  |

| Storage ( $m^3$ ) |          |         |             |         |
|-------------------|----------|---------|-------------|---------|
| Overflow          | Required | Surface | Sub-surface | Balance |
| 0.00              | 22.86    | 23.09   | 0           | 0.00    |

| Drainage Area                | 1D                  |   |             |                   |                      |
|------------------------------|---------------------|---|-------------|-------------------|----------------------|
| Area (Ha)                    | 0.057               |   |             |                   |                      |
| C =                          | 0.90                |   |             |                   |                      |
| Restricted Flow $Q_r$ (L/s)= |                     | 2.520   |             |                   |                      |
| 5-Year Ponding               |                     |   |             |                   |                      |
| $T_c$ Variable (min)         | $i_{5yr}$ (mm/hour) | Peak Flow $Q_p = 2.78 \times C_i \times 5yr \times A$ (L/s) | $Q_r$ (L/s) | $Q_p - Q_r$ (L/s) | Volume 5yr ( $m^3$ ) |
| 19                           | 72.53               | 10.34   | 2.52        | 7.82              | 8.92                 |
| 24                           | 62.54               | 8.92  | 2.52        | 6.40              | 9.21                 |
| 29                           | 55.18               | 7.87  | 2.52        | 5.35              | 9.31                 |
| 34                           | 49.50               | 7.06  | 2.52        | 4.54              | 9.26                 |
| 39                           | 44.98               | 6.41  | 2.52        | 3.89              | 9.11                 |

| Storage ( $m^3$ ) |          |         |             |         |
|-------------------|----------|---------|-------------|---------|
| Overflow          | Required | Surface | Sub-surface | Balance |
| 0.00              | 9.31     | 23.09   | 0           | 0.00    |

| Drainage Area                | 1D                  |   |             |                   |                      |
|------------------------------|---------------------|---|-------------|-------------------|----------------------|
| Area (Ha)                    | 0.057               |   |             |                   |                      |
| C =                          | 0.90                |   |             |                   |                      |
| Restricted Flow $Q_r$ (L/s)= |                     | 2.520   |             |                   |                      |
| 2-Year Ponding               |                     |   |             |                   |                      |
| $T_c$ Variable (min)         | $i_{2yr}$ (mm/hour) | Peak Flow $Q_p = 2.78 \times C_i \times 2yr \times A$ (L/s) | $Q_r$ (L/s) | $Q_p - Q_r$ (L/s) | Volume 2yr ( $m^3$ ) |
| 14                           | 64.23               | 9.16  | 2.52        | 6.64              | 5.58                 |
| 19                           | 53.70               | 7.66  | 2.52        | 5.14              | 5.86                 |
| 24                           | 46.37               | 6.61  | 2.52        | 4.09              | 5.89                 |
| 29                           | 40.96               | 5.84  | 2.52        | 3.32              | 5.78                 |
| 39                           | 33.45               | 4.77  | 2.52        | 2.25              | 5.27                 |

| Storage ( $m^3$ ) |          |         |             |         |
|-------------------|----------|---------|-------------|---------|
| Overflow          | Required | Surface | Sub-surface | Balance |
| 0.00              | 5.89     | 23.09   | 0           | 0.00    |

| Drainage Area                 |                              | Roof Area 1E  |                      |                                      |                                |
|-------------------------------|------------------------------|---|----------------------|--------------------------------------|--------------------------------|
| Area (Ha)                     | 0.063                        |   |                      |                                      |                                |
| C =                           | 1.00                         | Restricted Flow Q <sub>r</sub> (L/s)= 3.150                 |                      |                                      |                                |
| 100-Year Ponding              |                              |   |                      |                                      |                                |
| T <sub>c</sub> Variable (min) | i <sub>100yr</sub> (mm/hour) | Peak Flow Q <sub>p</sub> = 2.78xCi <sub>100yr</sub> A (L/s) | Q <sub>r</sub> (L/s) | Q <sub>p</sub> -Q <sub>r</sub> (L/s) | Volume 100yr (m <sup>3</sup> ) |
| 40                            | 75.15                        | 13.16   | 3.15                 | 10.01                                | 24.03                          |
| 45                            | 69.05                        | 12.09   | 3.15                 | 8.94                                 | 24.15                          |
| 50                            | 63.95                        | 11.20   | 3.15                 | 8.05                                 | <b>24.15</b>                   |
| 55                            | 59.62                        | 10.44   | 3.15                 | 7.29                                 | 24.07                          |
| 65                            | 52.65                        | 9.22  | 3.15                 | 6.07                                 | 23.67                          |

| Storage (m <sup>3</sup> ) |          |         |             |         |
|---------------------------|----------|---------|-------------|---------|
| Overflow                  | Required | Surface | Sub-surface | Balance |
| 0.00                      | 24.15    | 25.20   | 0           | 0.00    |

| Drainage Area                 |                            | Roof Area 1E  |                      |                                      |                              |
|-------------------------------|----------------------------|---|----------------------|--------------------------------------|------------------------------|
| Area (Ha)                     | 0.063                      |   |                      |                                      |                              |
| C =                           | 0.90                       | Restricted Flow Q <sub>r</sub> (L/s)= 3.150               |                      |                                      |                              |
| 5-Year Ponding                |                            |   |                      |                                      |                              |
| T <sub>c</sub> Variable (min) | i <sub>5yr</sub> (mm/hour) | Peak Flow Q <sub>p</sub> = 2.78xCi <sub>5yr</sub> A (L/s) | Q <sub>r</sub> (L/s) | Q <sub>p</sub> -Q <sub>r</sub> (L/s) | Volume 5yr (m <sup>3</sup> ) |
| 15                            | 83.56                      | 13.17   | 3.15                 | 10.02                                | 9.02                         |
| 20                            | 70.25                      | 11.07   | 3.15                 | 7.92                                 | 9.51                         |
| 25                            | 60.90                      | 9.60  | 3.15                 | 6.45                                 | <b>9.67</b>                  |
| 30                            | 53.93                      | 8.50  | 3.15                 | 5.35                                 | 9.63                         |
| 35                            | 48.52                      | 7.65  | 3.15                 | 4.50                                 | 9.45                         |

| Storage (m <sup>3</sup> ) |          |         |             |         |
|---------------------------|----------|---------|-------------|---------|
| Overflow                  | Required | Surface | Sub-surface | Balance |
| 0.00                      | 9.67     | 25.20   | 0           | 0.00    |

| Drainage Area                 |                            | Roof Area 1E  |                      |                                      |                              |
|-------------------------------|----------------------------|---|----------------------|--------------------------------------|------------------------------|
| Area (Ha)                     | 0.063                      |   |                      |                                      |                              |
| C =                           | 0.90                       | Restricted Flow Q <sub>r</sub> (L/s)= 3.150               |                      |                                      |                              |
| 2-Year Ponding                |                            |   |                      |                                      |                              |
| T <sub>c</sub> Variable (min) | i <sub>2yr</sub> (mm/hour) | Peak Flow Q <sub>p</sub> = 2.78xCi <sub>2yr</sub> A (L/s) | Q <sub>r</sub> (L/s) | Q <sub>p</sub> -Q <sub>r</sub> (L/s) | Volume 2yr (m <sup>3</sup> ) |
| 9                             | 80.87                      | 12.75   | 3.15                 | 9.60                                 | 5.18                         |
| 14                            | 64.23                      | 10.12   | 3.15                 | 6.97                                 | 5.86                         |
| 19                            | 53.70                      | 8.46  | 3.15                 | 5.31                                 | <b>6.06</b>                  |
| 24                            | 46.37                      | 7.31  | 3.15                 | 4.16                                 | 5.99                         |
| 34                            | 36.78                      | 5.80  | 3.15                 | 2.65                                 | 5.40                         |

| Storage (m <sup>3</sup> ) |          |         |             |         |
|---------------------------|----------|---------|-------------|---------|
| Overflow                  | Required | Surface | Sub-surface | Balance |
| 0.00                      | 6.06     | 25.20   | 0           | 0.00    |

| Drainage Area                 |                              | Roof Area 2A  |                      |                                      |                                |
|-------------------------------|------------------------------|---|----------------------|--------------------------------------|--------------------------------|
| Area (Ha)                     | 0.044                        |   |                      |                                      |                                |
| C =                           | 1.00                         | Restricted Flow Q <sub>r</sub> (L/s)= 2.520                 |                      |                                      |                                |
| 100-Year Ponding              |                              |   |                      |                                      |                                |
| T <sub>c</sub> Variable (min) | i <sub>100yr</sub> (mm/hour) | Peak Flow Q <sub>p</sub> = 2.78xCi <sub>100yr</sub> A (L/s) | Q <sub>r</sub> (L/s) | Q <sub>p</sub> -Q <sub>r</sub> (L/s) | Volume 100yr (m <sup>3</sup> ) |
| 30                            | 91.87                        | 11.24   | 2.52                 | 8.72                                 | 15.69                          |
| 35                            | 82.58                        | 10.10   | 2.52                 | 7.58                                 | 15.92                          |
| 40                            | 75.15                        | 9.19  | 2.52                 | 6.67                                 | <b>16.01</b>                   |
| 45                            | 69.05                        | 8.45  | 2.52                 | 5.93                                 | 16.00                          |
| 55                            | 59.62                        | 7.29  | 2.52                 | 4.77                                 | 15.75                          |

| Storage (m <sup>3</sup> ) |          |         |             |         |
|---------------------------|----------|---------|-------------|---------|
| Overflow                  | Required | Surface | Sub-surface | Balance |
| 0.00                      | 16.01    | 17.60   | 0           | 0.00    |

| Drainage Area                 |                            | Roof Area 2A  |                      |                                      |                              |
|-------------------------------|----------------------------|---|----------------------|--------------------------------------|------------------------------|
| Area (Ha)                     | 0.044                      |   |                      |                                      |                              |
| C =                           | 0.90                       | Restricted Flow Q <sub>r</sub> (L/s)= 2.520               |                      |                                      |                              |
| 5-Year Ponding                |                            |   |                      |                                      |                              |
| T <sub>c</sub> Variable (min) | i <sub>5yr</sub> (mm/hour) | Peak Flow Q <sub>p</sub> = 2.78xCi <sub>5yr</sub> A (L/s) | Q <sub>r</sub> (L/s) | Q <sub>p</sub> -Q <sub>r</sub> (L/s) | Volume 5yr (m <sup>3</sup> ) |
| 14                            | 86.93                      | 9.57  | 2.52                 | 7.05                                 | 5.92                         |
| 19                            | 72.53                      | 7.98  | 2.52                 | 5.46                                 | 6.23                         |
| 24                            | 62.54                      | 6.88  | 2.52                 | 4.36                                 | <b>6.29</b>                  |
| 29                            | 55.18                      | 6.07  | 2.52                 | 3.55                                 | 6.18                         |
| 34                            | 49.50                      | 5.45  | 2.52                 | 2.93                                 | 5.98                         |

| Storage (m <sup>3</sup> ) |          |         |             |         |
|---------------------------|----------|---------|-------------|---------|
| Overflow                  | Required | Surface | Sub-surface | Balance |
| 0.00                      | 6.29     | 17.60   | 0           | 0.00    |

| Drainage Area                 |                            | Roof Area 2A  |                      |                                      |                              |
|-------------------------------|----------------------------|---|----------------------|--------------------------------------|------------------------------|
| Area (Ha)                     | 0.044                      |   |                      |                                      |                              |
| C =                           | 0.90                       | Restricted Flow Q <sub>r</sub> (L/s)= 2.520               |                      |                                      |                              |
| 2-Year Ponding                |                            |   |                      |                                      |                              |
| T <sub>c</sub> Variable (min) | i <sub>2yr</sub> (mm/hour) | Peak Flow Q <sub>p</sub> = 2.78xCi <sub>2yr</sub> A (L/s) | Q <sub>r</sub> (L/s) | Q <sub>p</sub> -Q <sub>r</sub> (L/s) | Volume 2yr (m <sup>3</sup> ) |
| 9                             | 80.87                      | 8.90  | 2.52                 | 6.38                                 | 3.45                         |
| 14                            | 64.23                      | 7.07  | 2.52                 | 4.55                                 | 3.82                         |
| 19                            | 53.70                      | 5.91  | 2.52                 | 3.39                                 | <b>3.87</b>                  |
| 24                            | 46.37                      | 5.11  | 2.52                 | 2.59                                 | 3.72                         |
| 34                            | 36.78                      | 4.05  | 2.52                 | 1.53                                 | 3.12                         |

| Storage (m <sup>3</sup> ) |          |         |             |         |
|---------------------------|----------|---------|-------------|---------|
| Overflow                  | Required | Surface | Sub-surface | Balance |
| 0.00                      | 3.87     | 17.60   | 0           | 0.00    |

| Drainage Area                 |                              | Roof Area 2B  |                      |                                      |                                |
|-------------------------------|------------------------------|---|----------------------|--------------------------------------|--------------------------------|
| Area (Ha)                     | 0.077                        |   |                      |                                      |                                |
| C =                           | 1.00                         | Restricted Flow Q <sub>r</sub> (L/s)= 3.150                 |                      |                                      |                                |
| 100-Year Ponding              |                              |   |                      |                                      |                                |
| T <sub>c</sub> Variable (min) | i <sub>100yr</sub> (mm/hour) | Peak Flow Q <sub>p</sub> = 2.78xCi <sub>100yr</sub> A (L/s) | Q <sub>r</sub> (L/s) | Q <sub>p</sub> -Q <sub>r</sub> (L/s) | Volume 100yr (m <sup>3</sup> ) |
| 50                            | 63.95                        | 13.69   | 3.15                 | 10.54                                | 31.62                          |
| 55                            | 59.62                        | 12.76   | 3.15                 | 9.61                                 | 31.72                          |
| 60                            | 55.89                        | 11.96   | 3.15                 | 8.81                                 | <b>31.73</b>                   |
| 65                            | 52.65                        | 11.27   | 3.15                 | 8.12                                 | 31.67                          |
| 75                            | 47.26                        | 10.12   | 3.15                 | 6.97                                 | 31.34                          |

| Storage (m <sup>3</sup> ) |          |         |             |         |
|---------------------------|----------|---------|-------------|---------|
| Overflow                  | Required | Surface | Sub-surface | Balance |
| 0.00                      | 31.73    | 32.73   | 0           | 0.00    |

| Drainage Area                 |                            | Roof Area 2B  |                      |                                      |                              |
|-------------------------------|----------------------------|---|----------------------|--------------------------------------|------------------------------|
| Area (Ha)                     | 0.077                      |   |                      |                                      |                              |
| C =                           | 0.90                       | Restricted Flow Q <sub>r</sub> (L/s)= 3.150               |                      |                                      |                              |
| 5-Year Ponding                |                            |   |                      |                                      |                              |
| T <sub>c</sub> Variable (min) | i <sub>5yr</sub> (mm/hour) | Peak Flow Q <sub>p</sub> = 2.78xCi <sub>5yr</sub> A (L/s) | Q <sub>r</sub> (L/s) | Q <sub>p</sub> -Q <sub>r</sub> (L/s) | Volume 5yr (m <sup>3</sup> ) |
| 24                            | 62.54                      | 12.05   | 3.15                 | 8.90                                 | 12.81                        |
| 29                            | 55.18                      | 10.63   | 3.15                 | 7.48                                 | 13.02                        |
| 34                            | 49.50                      | 9.54  | 3.15                 | 6.39                                 | <b>13.03</b>                 |
| 39                            | 44.98                      | 8.67  | 3.15                 | 5.52                                 | 12.91                        |
| 44                            | 41.29                      | 7.95  | 3.15                 | 4.80                                 | 12.68                        |

| Storage (m <sup>3</sup> ) |          |         |             |         |
|---------------------------|----------|---------|-------------|---------|
| Overflow                  | Required | Surface | Sub-surface | Balance |
| 0.00                      | 13.03    | 32.73   | 0           | 0.00    |

| Drainage Area                 |                            | Roof Area 2B  |                      |                                      |                              |
|-------------------------------|----------------------------|---|----------------------|--------------------------------------|------------------------------|
| Area (Ha)                     | 0.077                      |   |                      |                                      |                              |
| C =                           | 0.90                       | Restricted Flow Q <sub>r</sub> (L/s)= 3.150               |                      |                                      |                              |
| 2-Year Ponding                |                            |   |                      |                                      |                              |
| T <sub>c</sub> Variable (min) | i <sub>2yr</sub> (mm/hour) | Peak Flow Q <sub>p</sub> = 2.78xCi <sub>2yr</sub> A (L/s) | Q <sub>r</sub> (L/s) | Q <sub>p</sub> -Q <sub>r</sub> (L/s) | Volume 2yr (m <sup>3</sup> ) |
| 14                            | 64.23                      | 12.37   | 3.15                 | 9.22                                 | 7.75                         |
| 19                            | 53.70                      | 10.35   | 3.15                 | 7.20                                 | 8.20                         |
| 24                            | 46.37                      | 8.93  | 3.15                 | 5.78                                 | <b>8.33</b>                  |
| 29                            | 40.96                      | 7.89  | 3.15                 | 4.74                                 | 8.25                         |
| 39                            | 33.45                      | 6.44  | 3.15                 | 3.29                                 | 7.71                         |

| Storage (m <sup>3</sup> ) |          |         |             |         |
|---------------------------|----------|---------|-------------|---------|
| Overflow                  | Required | Surface | Sub-surface | Balance |
| 0.00                      | 8.33     | 32.73   | 0           | 0.00    |

| Drainage Area        |                       | Roof Area 2C                                     |             |                   |                        |
|----------------------|-----------------------|--|-------------|-------------------|------------------------|
| Area (Ha)            |                       | 0.029  |             |                   |                        |
| C =                  | 1.00                  | Restricted Flow $Q_r$ (L/s)= 1.890               |             |                   |                        |
| 100-Year Ponding     |                       |  |             |                   |                        |
| $T_c$ Variable (min) | $i_{100yr}$ (mm/hour) | Peak Flow $Q_p = 2.78 \times Ci_{100yr} A$ (L/s) | $Q_r$ (L/s) | $Q_p - Q_r$ (L/s) | Volume 100yr ( $m^3$ ) |
| 25                   | 103.85                | 8.37   | 1.89        | 6.48              | 9.72                   |
| 30                   | 91.87                 | 7.41   | 1.89        | 5.52              | 9.93                   |
| 35                   | 82.58                 | 6.66   | 1.89        | 4.77              | 10.01                  |
| 40                   | 75.15                 | 6.06   | 1.89        | 4.17              | 10.00                  |
| 50                   | 63.95                 | 5.16   | 1.89        | 3.27              | 9.80                   |

| Storage ( $m^3$ ) |          |         |             |         |  |
|-------------------|----------|---------|-------------|---------|--|
| Overflow          | Required | Surface | Sub-surface | Balance |  |
| 0.00              | 10.01    | 11.60   | 0           | 0.00    |  |

| Drainage Area        |                     | Roof Area 2C                                   |             |                   |                      |
|----------------------|---------------------|--|-------------|-------------------|----------------------|
| Area (Ha)            |                     | 0.029  |             |                   |                      |
| C =                  | 0.90                | Restricted Flow $Q_r$ (L/s)= 1.890             |             |                   |                      |
| 5-Year Ponding       |                     |  |             |                   |                      |
| $T_c$ Variable (min) | $i_{5yr}$ (mm/hour) | Peak Flow $Q_p = 2.78 \times Ci_{5yr} A$ (L/s) | $Q_r$ (L/s) | $Q_p - Q_r$ (L/s) | Volume 5yr ( $m^3$ ) |
| 9                    | 109.79              | 7.97   | 1.89        | 6.08              | 3.28                 |
| 14                   | 86.93               | 6.31   | 1.89        | 4.42              | 3.71                 |
| 19                   | 72.53               | 5.26   | 1.89        | 3.37              | 3.84                 |
| 24                   | 62.54               | 4.54   | 1.89        | 2.65              | 3.81                 |
| 29                   | 55.18               | 4.00   | 1.89        | 2.11              | 3.68                 |

| Storage ( $m^3$ ) |          |         |             |         |  |
|-------------------|----------|---------|-------------|---------|--|
| Overflow          | Required | Surface | Sub-surface | Balance |  |
| 0.00              | 3.84     | 11.60   | 0           | 0.00    |  |

| Drainage Area        |                     | Roof Area 2C                                   |             |                   |                      |
|----------------------|---------------------|--|-------------|-------------------|----------------------|
| Area (Ha)            |                     | 0.029  |             |                   |                      |
| C =                  | 0.90                | Restricted Flow $Q_r$ (L/s)= 1.890             |             |                   |                      |
| 2-Year Ponding       |                     |  |             |                   |                      |
| $T_c$ Variable (min) | $i_{2yr}$ (mm/hour) | Peak Flow $Q_p = 2.78 \times Ci_{2yr} A$ (L/s) | $Q_r$ (L/s) | $Q_p - Q_r$ (L/s) | Volume 2yr ( $m^3$ ) |
| 5                    | 103.57              | 7.51   | 1.89        | 5.62              | 1.69                 |
| 10                   | 76.81               | 5.57   | 1.89        | 3.68              | 2.21                 |
| 15                   | 61.77               | 4.48   | 1.89        | 2.59              | 2.33                 |
| 20                   | 52.03               | 3.78   | 1.89        | 1.89              | 2.26                 |
| 30                   | 40.04               | 2.91   | 1.89        | 1.02              | 1.83                 |

| Storage ( $m^3$ ) |          |         |             |         |  |
|-------------------|----------|---------|-------------|---------|--|
| Overflow          | Required | Surface | Sub-surface | Balance |  |
| 0.00              | 2.33     | 11.60   | 0           | 0.00    |  |

| Drainage Area        |                       | Roof Area 2D                                     |             |                   |                        |
|----------------------|-----------------------|--|-------------|-------------------|------------------------|
| Area (Ha)            |                       | 0.057  |             |                   |                        |
| C =                  | 1.00                  | Restricted Flow $Q_r$ (L/s)= 2.520               |             |                   |                        |
| 100-Year Ponding     |                       |  |             |                   |                        |
| $T_c$ Variable (min) | $i_{100yr}$ (mm/hour) | Peak Flow $Q_p = 2.78 \times Ci_{100yr} A$ (L/s) | $Q_r$ (L/s) | $Q_p - Q_r$ (L/s) | Volume 100yr ( $m^3$ ) |
| 45                   | 69.05                 | 10.94  | 2.52        | 8.42              | 22.74                  |
| 50                   | 63.95                 | 10.13  | 2.52        | 7.61              | 22.84                  |
| 55                   | 59.82                 | 9.45   | 2.52        | 6.93              | 22.86                  |
| 60                   | 55.89                 | 8.86   | 2.52        | 6.34              | 22.81                  |
| 70                   | 49.79                 | 7.89   | 2.52        | 5.37              | 22.55                  |

| Storage ( $m^3$ ) |          |         |             |         |  |
|-------------------|----------|---------|-------------|---------|--|
| Overflow          | Required | Surface | Sub-surface | Balance |  |
| 0.00              | 22.86    | 23.09   | 0           | 0.00    |  |

| Drainage Area        |                     | Roof Area 2D                                   |             |                   |                      |
|----------------------|---------------------|--|-------------|-------------------|----------------------|
| Area (Ha)            |                     | 0.057  |             |                   |                      |
| C =                  | 0.90                | Restricted Flow $Q_r$ (L/s)= 2.520             |             |                   |                      |
| 5-Year Ponding       |                     |  |             |                   |                      |
| $T_c$ Variable (min) | $i_{5yr}$ (mm/hour) | Peak Flow $Q_p = 2.78 \times Ci_{5yr} A$ (L/s) | $Q_r$ (L/s) | $Q_p - Q_r$ (L/s) | Volume 5yr ( $m^3$ ) |
| 19                   | 72.53               | 10.34  | 2.52        | 7.82              | 8.92                 |
| 24                   | 62.54               | 8.92   | 2.52        | 6.40              | 9.21                 |
| 29                   | 55.18               | 7.87   | 2.52        | 5.35              | 9.31                 |
| 34                   | 49.50               | 7.06   | 2.52        | 4.54              | 9.26                 |
| 39                   | 44.98               | 6.41   | 2.52        | 3.89              | 9.11                 |

| Storage ( $m^3$ ) |          |         |             |         |  |
|-------------------|----------|---------|-------------|---------|--|
| Overflow          | Required | Surface | Sub-surface | Balance |  |
| 0.00              | 9.31     | 23.09   | 0           | 0.00    |  |

| Drainage Area        |                     | Roof Area 2D                                   |             |                   |                      |
|----------------------|---------------------|--|-------------|-------------------|----------------------|
| Area (Ha)            |                     | 0.057  |             |                   |                      |
| C =                  | 0.90                | Restricted Flow $Q_r$ (L/s)= 2.520             |             |                   |                      |
| 2-Year Ponding       |                     |  |             |                   |                      |
| $T_c$ Variable (min) | $i_{2yr}$ (mm/hour) | Peak Flow $Q_p = 2.78 \times Ci_{2yr} A$ (L/s) | $Q_r$ (L/s) | $Q_p - Q_r$ (L/s) | Volume 2yr ( $m^3$ ) |
| 14                   | 64.23               | 9.16   | 2.52        | 6.64              | 5.58                 |
| 19                   | 53.70               | 7.66   | 2.52        | 5.14              | 5.86                 |
| 24                   | 46.37               | 6.61   | 2.52        | 4.09              | 5.89                 |
| 29                   | 40.96               | 5.84   | 2.52        | 3.32              | 5.78                 |
| 39                   | 33.45               | 4.77   | 2.52        | 2.25              | 5.27                 |

| Storage ( $m^3$ ) |          |         |             |         |  |
|-------------------|----------|---------|-------------|---------|--|
| Overflow          | Required | Surface | Sub-surface | Balance |  |
| 0.00              | 5.89     | 23.09   | 0           | 0.00    |  |

| Drainage Area        |                       | Roof Area 2E                                     |             |                   |                        |
|----------------------|-----------------------|--|-------------|-------------------|------------------------|
| Area (Ha)            |                       | 0.029  |             |                   |                        |
| C =                  | 1.00                  | Restricted Flow $Q_r$ (L/s)= 1.890               |             |                   |                        |
| 100-Year Ponding     |                       |  |             |                   |                        |
| $T_c$ Variable (min) | $i_{100yr}$ (mm/hour) | Peak Flow $Q_p = 2.78 \times Ci_{100yr} A$ (L/s) | $Q_r$ (L/s) | $Q_p - Q_r$ (L/s) | Volume 100yr ( $m^3$ ) |
| 25                   | 103.85                | 8.37   | 1.89        | 6.48              | 9.72                   |
| 30                   | 91.87                 | 7.41   | 1.89        | 5.52              | 9.93                   |
| 35                   | 82.58                 | 6.66   | 1.89        | 4.77              | 10.01                  |
| 40                   | 75.15                 | 6.06   | 1.89        | 4.17              | 10.00                  |
| 50                   | 63.95                 | 5.16   | 1.89        | 3.27              | 9.80                   |

| Storage ( $m^3$ ) |          |         |             |         |  |
|-------------------|----------|---------|-------------|---------|--|
| Overflow          | Required | Surface | Sub-surface | Balance |  |
| 0.00              | 10.01    | 11.60   | 0           | 0.00    |  |

| Drainage Area        |                     | Roof Area 2E                                   |             |                   |                      |
|----------------------|---------------------|--|-------------|-------------------|----------------------|
| Area (Ha)            |                     | 0.029  |             |                   |                      |
| C =                  | 0.90                | Restricted Flow $Q_r$ (L/s)= 1.890             |             |                   |                      |
| 5-Year Ponding       |                     |  |             |                   |                      |
| $T_c$ Variable (min) | $i_{5yr}$ (mm/hour) | Peak Flow $Q_p = 2.78 \times Ci_{5yr} A$ (L/s) | $Q_r$ (L/s) | $Q_p - Q_r$ (L/s) | Volume 5yr ( $m^3$ ) |
| 9                    | 109.79              | 7.97   | 1.89        | 6.08              | 3.28                 |
| 14                   | 86.93               | 6.31   | 1.89        | 4.42              | 3.71                 |
| 19                   | 72.53               | 5.26   | 1.89        | 3.37              | 3.84                 |
| 24                   | 62.54               | 4.54   | 1.89        | 2.65              | 3.81                 |
| 29                   | 55.18               | 4.00   | 1.89        | 2.11              | 3.68                 |

| Storage ( $m^3$ ) |          |         |             |         |  |
|-------------------|----------|---------|-------------|---------|--|
| Overflow          | Required | Surface | Sub-surface | Balance |  |
| 0.00              | 3.84     | 11.60   | 0           | 0.00    |  |

| Drainage Area        |                     | Roof Area 2E                                   |             |                   |                      |
|----------------------|---------------------|--|-------------|-------------------|----------------------|
| Area (Ha)            |                     | 0.029  |             |                   |                      |
| C =                  | 0.90                | Restricted Flow $Q_r$ (L/s)= 1.890             |             |                   |                      |
| 2-Year Ponding       |                     |  |             |                   |                      |
| $T_c$ Variable (min) | $i_{2yr}$ (mm/hour) | Peak Flow $Q_p = 2.78 \times Ci_{2yr} A$ (L/s) | $Q_r$ (L/s) | $Q_p - Q_r$ (L/s) | Volume 2yr ( $m^3$ ) |
| 5                    | 103.57              | 7.51   | 1.89        | 5.62              | 1.69                 |
| 10                   | 76.81               | 5.57   | 1.89        | 3.68              | 2.21                 |
| 15                   | 61.77               | 4.48   | 1.89        | 2.59              | 2.33                 |
| 20                   | 52.03               | 3.78   | 1.89        | 1.89              | 2.26                 |
| 30                   | 40.04               | 2.91   | 1.89        | 1.02              | 1.83                 |

| Storage ( $m^3$ ) |          |         |             |         |  |
|-------------------|----------|---------|-------------|---------|--|
| Overflow          | Required | Surface | Sub-surface | Balance |  |
| 0.00              | 2.33     | 11.60   | 0           | 0.00    |  |

| Drainage Area                 |                              | Roof Area 2F  |                      |                                      |                                |
|-------------------------------|------------------------------|---|----------------------|--------------------------------------|--------------------------------|
| Area (Ha)                     | 0.059                        | ICD Size (L/s)=   |                      |                                      |                                |
| C =                           | 1.00                         | Restricted Flow Q <sub>r</sub> (L/s)= 3.150                 |                      |                                      |                                |
| 100-Year Ponding              |                              |   |                      |                                      |                                |
| T <sub>c</sub> Variable (min) | i <sub>100yr</sub> (mm/hour) | Peak Flow Q <sub>p</sub> = 2.78xCi <sub>100yr</sub> A (L/s) | Q <sub>r</sub> (L/s) | Q <sub>p</sub> -Q <sub>r</sub> (L/s) | Volume 100yr (m <sup>3</sup> ) |
| 35                            | 82.58                        | 13.54   | 3.15                 | 10.39                                | 21.83                          |
| 40                            | 75.15                        | 12.33   | 3.15                 | 9.18                                 | 22.02                          |
| 45                            | 69.05                        | 11.33   | 3.15                 | 8.18                                 | <b>22.07</b>                   |
| 50                            | 63.95                        | 10.49   | 3.15                 | 7.34                                 | 22.02                          |
| 60                            | 55.89                        | 9.17  | 3.15                 | 6.02                                 | 21.66                          |

| Storage (m <sup>3</sup> ) |      |             |       |         |       |
|---------------------------|------|-------------|-------|---------|-------|
| Overflow                  | 0.00 | Required    | 22.07 | Surface | 23.60 |
|                           |      | Sub-surface | 0     | Balance | 0.00  |

| Drainage Area                 |                            | Roof Area 2F  |                      |                                      |                              |
|-------------------------------|----------------------------|---|----------------------|--------------------------------------|------------------------------|
| Area (Ha)                     | 0.059                      | ICD Size (L/s)=   |                      |                                      |                              |
| C =                           | 0.90                       | Restricted Flow Q <sub>r</sub> (L/s)= 3.150               |                      |                                      |                              |
| 5-Year Ponding                |                            |   |                      |                                      |                              |
| T <sub>c</sub> Variable (min) | i <sub>5yr</sub> (mm/hour) | Peak Flow Q <sub>p</sub> = 2.78xCi <sub>5yr</sub> A (L/s) | Q <sub>r</sub> (L/s) | Q <sub>p</sub> -Q <sub>r</sub> (L/s) | Volume 5yr (m <sup>3</sup> ) |
| 16                            | 80.46                      | 11.88   | 3.15                 | 8.73                                 | 8.38                         |
| 21                            | 68.13                      | 10.06   | 3.15                 | 6.91                                 | 8.70                         |
| 26                            | 59.35                      | 8.76  | 3.15                 | 5.61                                 | <b>8.75</b>                  |
| 31                            | 52.74                      | 7.79  | 3.15                 | 4.64                                 | 8.62                         |
| 36                            | 47.58                      | 7.02  | 3.15                 | 3.87                                 | 8.37                         |

| Storage (m <sup>3</sup> ) |      |             |      |         |       |
|---------------------------|------|-------------|------|---------|-------|
| Overflow                  | 0.00 | Required    | 8.75 | Surface | 23.60 |
|                           |      | Sub-surface | 0    | Balance | 0.00  |

| Drainage Area                 |                            | Roof Area 2F  |                      |                                      |                              |
|-------------------------------|----------------------------|---|----------------------|--------------------------------------|------------------------------|
| Area (Ha)                     | 0.059                      | ICD Size (L/s)=   |                      |                                      |                              |
| C =                           | 0.90                       | Restricted Flow Q <sub>r</sub> (L/s)= 3.150               |                      |                                      |                              |
| 2-Year Ponding                |                            |   |                      |                                      |                              |
| T <sub>c</sub> Variable (min) | i <sub>2yr</sub> (mm/hour) | Peak Flow Q <sub>p</sub> = 2.78xCi <sub>2yr</sub> A (L/s) | Q <sub>r</sub> (L/s) | Q <sub>p</sub> -Q <sub>r</sub> (L/s) | Volume 2yr (m <sup>3</sup> ) |
| 8                             | 85.46                      | 12.61   | 3.15                 | 9.46                                 | 4.54                         |
| 13                            | 66.93                      | 9.88  | 3.15                 | 6.73                                 | 5.25                         |
| 18                            | 55.49                      | 8.19  | 3.15                 | 5.04                                 | <b>5.44</b>                  |
| 23                            | 47.66                      | 7.04  | 3.15                 | 3.89                                 | 5.36                         |
| 33                            | 37.54                      | 5.54  | 3.15                 | 2.39                                 | 4.74                         |

| Storage (m <sup>3</sup> ) |      |             |      |         |       |
|---------------------------|------|-------------|------|---------|-------|
| Overflow                  | 0.00 | Required    | 5.44 | Surface | 23.60 |
|                           |      | Sub-surface | 0    | Balance | 0.00  |

| Drainage Area                 |                              | deck  |                      |                                      |                                |
|-------------------------------|------------------------------|---|----------------------|--------------------------------------|--------------------------------|
| Area (Ha)                     | 0.507                        | ICD Size (L/s)= 40.52                                       |                      |                                      |                                |
| C =                           | 1.00                         | Reduced Restricted Flow Q <sub>r</sub> (L/s)= 20.259        |                      |                                      |                                |
| 100-Year Ponding              |                              |   |                      |                                      |                                |
| T <sub>c</sub> Variable (min) | i <sub>100yr</sub> (mm/hour) | Peak Flow Q <sub>p</sub> = 2.78xCi <sub>100yr</sub> A (L/s) | Q <sub>r</sub> (L/s) | Q <sub>p</sub> -Q <sub>r</sub> (L/s) | Volume 100yr (m <sup>3</sup> ) |
| 52                            | 62.14                        | 87.58   | 20.26                | 67.33                                | 210.06                         |
| 57                            | 58.07                        | 81.84   | 20.26                | 61.58                                | 210.62                         |
| 60                            | 55.89                        | 78.78   | 20.26                | 58.52                                | <b>210.68</b>                  |
| 63                            | 53.89                        | 75.96   | 20.26                | 55.70                                | 210.56                         |
| 68                            | 50.89                        | 71.73   | 20.26                | 51.47                                | 209.99                         |

| Storage (m <sup>3</sup> ) |      |             |        |         |      |
|---------------------------|------|-------------|--------|---------|------|
| Overflow                  | 0.00 | Required    | 210.68 | Surface |      |
|                           |      | Sub-surface | 210    | Balance | 0.68 |

| Drainage Area                 |                            | deck  |                      |                                      |                              |
|-------------------------------|----------------------------|---|----------------------|--------------------------------------|------------------------------|
| Area (Ha)                     | 0.507                      | ICD Size (L/s)= 40.52                                     |                      |                                      |                              |
| C =                           | 0.90                       | Reduced Restricted Flow Q <sub>r</sub> (L/s)= 20.259      |                      |                                      |                              |
| 5-Year Ponding                |                            |   |                      |                                      |                              |
| T <sub>c</sub> Variable (min) | i <sub>5yr</sub> (mm/hour) | Peak Flow Q <sub>p</sub> = 2.78xCi <sub>5yr</sub> A (L/s) | Q <sub>r</sub> (L/s) | Q <sub>p</sub> -Q <sub>r</sub> (L/s) | Volume 5yr (m <sup>3</sup> ) |
| 28                            | 56.49                      | 71.66   | 20.26                | 51.40                                | 86.35                        |
| 30                            | 53.93                      | 68.41   | 20.26                | 48.15                                | 86.67                        |
| 32                            | 51.61                      | 65.47   | 20.26                | 45.21                                | <b>86.80</b>                 |
| 34                            | 49.50                      | 62.79   | 20.26                | 42.53                                | 86.77                        |
| 36                            | 47.58                      | 60.35   | 20.26                | 40.09                                | 86.60                        |

| Storage (m <sup>3</sup> ) |      |             |       |         |      |
|---------------------------|------|-------------|-------|---------|------|
| Overflow                  | 0.00 | Required    | 86.80 | Surface | 0.00 |
|                           |      | Sub-surface | 210   | Balance | 0.00 |

| Drainage Area                 |                            | deck  |                      |                                      |                              |
|-------------------------------|----------------------------|---|----------------------|--------------------------------------|------------------------------|
| Area (Ha)                     | 0.507                      | ICD Size (L/s)= 40.52                                     |                      |                                      |                              |
| C =                           | 0.90                       | Reduced Restricted Flow Q <sub>r</sub> (L/s)= 20.259      |                      |                                      |                              |
| 2-Year Ponding                |                            |   |                      |                                      |                              |
| T <sub>c</sub> Variable (min) | i <sub>2yr</sub> (mm/hour) | Peak Flow Q <sub>p</sub> = 2.78xCi <sub>2yr</sub> A (L/s) | Q <sub>r</sub> (L/s) | Q <sub>p</sub> -Q <sub>r</sub> (L/s) | Volume 2yr (m <sup>3</sup> ) |
| 23                            | 47.66                      | 60.45   | 20.26                | 40.19                                | 55.47                        |
| 24                            | 46.37                      | 58.83   | 20.26                | 38.57                                | 55.54                        |
| 25                            | 45.17                      | 57.29   | 20.26                | 37.04                                | <b>55.55</b>                 |
| 26                            | 44.03                      | 55.85   | 20.26                | 35.59                                | 55.52                        |
| 27                            | 42.95                      | 54.48   | 20.26                | 34.22                                | 55.44                        |

| Storage (m <sup>3</sup> ) |      |             |       |         |      |
|---------------------------|------|-------------|-------|---------|------|
| Overflow                  | 0.00 | Required    | 55.55 | Surface | 0.00 |
|                           |      | Sub-surface | 210   | Balance | 0.00 |

| AREA  | AREA  | c    | ac    |
|-------|-------|------|-------|
| L1A   | 0.036 | 0.30 | 0.011 |
| L1B   | 0.050 | 0.30 | 0.015 |
| L1C   | 0.048 | 0.30 | 0.014 |
| L1D   | 0.050 | 0.30 | 0.015 |
| L2A   | 0.032 | 0.30 | 0.010 |
| L2B   | 0.038 | 0.30 | 0.011 |
| L2C   | 0.041 | 0.30 | 0.012 |
| L4A   | 0.043 | 0.30 | 0.013 |
| L4B   | 0.026 | 0.30 | 0.008 |
| L6A   | 0.015 | 0.55 | 0.008 |
| L6B   | 0.017 | 0.55 | 0.009 |
|       | 0.396 |      | 0.127 |
| Avg C |       | 0.32 |       |

| Drainage Area                 |                              | LANDSCAPE   |                      |                                      |                                |
|-------------------------------|------------------------------|---|----------------------|--------------------------------------|--------------------------------|
| Area (Ha)                     | 0.396                        | ICD Size (L/s)= 11.26                                       |                      |                                      |                                |
| C =                           | 0.38                         | Reduced Restricted Flow Q <sub>r</sub> (L/s)= 5.630         |                      |                                      |                                |
| 100-Year Ponding              |                              |   |                      |                                      |                                |
| T <sub>c</sub> Variable (min) | i <sub>100yr</sub> (mm/hour) | Peak Flow Q <sub>p</sub> = 2.78xCi <sub>100yr</sub> A (L/s) | Q <sub>r</sub> (L/s) | Q <sub>p</sub> -Q <sub>r</sub> (L/s) | Volume 100yr (m <sup>3</sup> ) |
| 58                            | 57.32                        | 24.25   | 5.63                 | 18.62                                | 64.79                          |
| 63                            | 53.89                        | 22.80   | 5.63                 | 17.17                                | 64.89                          |
| 66                            | 52.05                        | 22.02   | 5.63                 | 16.39                                | <b>64.89</b>                   |
| 69                            | 50.33                        | 21.29   | 5.63                 | 15.66                                | 64.84                          |
| 74                            | 47.74                        | 20.19   | 5.63                 | 14.56                                | 64.66                          |

| Storage (m <sup>3</sup> ) |      |             |       |         |      |
|---------------------------|------|-------------|-------|---------|------|
| Overflow                  | 0.00 | Required    | 64.89 | Surface |      |
|                           |      | Sub-surface | 64.8  | Balance | 0.09 |

| Drainage Area                 |                            | LANDSCAPE   |                      |                                      |                              |
|-------------------------------|----------------------------|---|----------------------|--------------------------------------|------------------------------|
| Area (Ha)                     | 0.396                      | ICD Size (L/s)= 11.26                                     |                      |                                      |                              |
| C =                           | 0.32                       | Reduced Restricted Flow Q <sub>r</sub> (L/s)= 5.630       |                      |                                      |                              |
| 5-Year Ponding                |                            |   |                      |                                      |                              |
| T <sub>c</sub> Variable (min) | i <sub>5yr</sub> (mm/hour) | Peak Flow Q <sub>p</sub> = 2.78xCi <sub>5yr</sub> A (L/s) | Q <sub>r</sub> (L/s) | Q <sub>p</sub> -Q <sub>r</sub> (L/s) | Volume 5yr (m <sup>3</sup> ) |
| 28                            | 56.49                      | 19.91   | 5.63                 | 14.28                                | 24.00                        |
| 30                            | 53.93                      | 19.01   | 5.63                 | 13.38                                | 24.08                        |
| 32                            | 51.61                      | 18.19   | 5.63                 | 12.56                                | <b>24.12</b>                 |
| 34                            | 49.50                      | 17.45   | 5.63                 | 11.82                                | 24.11                        |
| 36                            | 47.58                      | 16.77   | 5.63                 | 11.14                                | 24.06                        |

| Storage (m <sup>3</sup> ) |      |             |       |         |      |
|---------------------------|------|-------------|-------|---------|------|
| Overflow                  | 0.00 | Required    | 24.12 | Surface | 0.00 |
|                           |      | Sub-surface | 64.8  | Balance | 0.00 |

| Drainage Area                 |                            | LANDSCAPE   |                      |                                      |                              |
|-------------------------------|----------------------------|---|----------------------|--------------------------------------|------------------------------|
| Area (Ha)                     | 0.396                      | ICD Size (L/s)= 11.26                                     |                      |                                      |                              |
| C =                           | 0.32                       | Reduced Restricted Flow Q <sub>r</sub> (L/s)= 5.630       |                      |                                      |                              |
| 2-Year Ponding                |                            |   |                      |                                      |                              |
| T <sub>c</sub> Variable (min) | i <sub>2yr</sub> (mm/hour) | Peak Flow Q <sub>p</sub> = 2.78xCi <sub>2yr</sub> A (L/s) | Q <sub>r</sub> (L/s) | Q <sub>p</sub> -Q <sub>r</sub> (L/s) | Volume 2yr (m <sup>3</sup> ) |
| 23                            | 47.66                      | 16.80   | 5.63                 | 11.17                                | 15.41                        |
| 24                            | 46.37                      | 16.35   | 5.63                 | 10.72                                | 15.43                        |
| 25                            | 45.17                      | 15.92   | 5.63                 | 10.29                                | <b>15.44</b>                 |
| 26                            | 44.03                      | 15.52   | 5.63                 | 9.89                                 | 15.43                        |
| 27                            | 42.95                      | 15.14   | 5.63                 | 9.51                                 | 15.41                        |

| Storage (m <sup>3</sup> ) |      |             |       |         |      |
|---------------------------|------|-------------|-------|---------|------|
| Overflow                  | 0.00 | Required    | 15.44 | Surface | 0.00 |
|                           |      | Sub-surface | 64.8  | Balance | 0.00 |

# APPENDIX E

- C-900 Sediment & Erosion Plan
- MVCA email
- C-200 Grading Plan



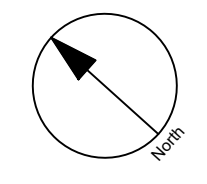

| ISSUES |                |            |
|--------|----------------|------------|
| No.    | DESCRIPTION    | DATE       |
| 1      | ISSUED FOR SPA | 2021/02/16 |
| 2      | SPA SUBMISSION | 2021       |

**NOT FOR CONSTRUCTION**

0 FOR NOTES, LEGEND



**CONSULTANTS**

Project Coordinator:  
North American Development Group

Architect:  
RLA Architecture

Surveyor:  
Fairhall, Moffatt and Woodland Ltd.

Geotechnical:  
Paterson Group

Traffic:  
JD Halpenny & Assoc.

Electrical:  
Hammerslag & Joffe Inc.

Landscape:  
NAK Design Strategies

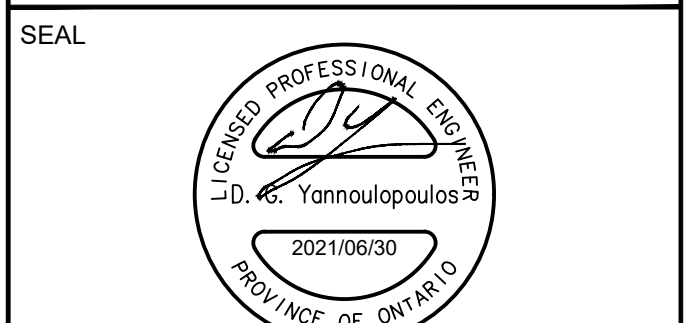
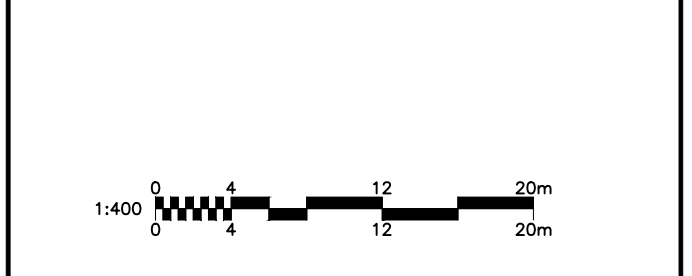

**PROJECT**  
21/35 HUNTMAR DRIVE

**PROJECT NO:**  
127134

**DRAWN BY:**  
EH

**PROJECT MGR:**  
DGY

**CHECKED BY:**  
DGY

**APPROVED BY:**  
DGY

**SHEET TITLE**  
EROSION AND SEDIMENTATION CONTROL PLAN

**SHEET NUMBER**  
C-900

**ISSUE**  
1

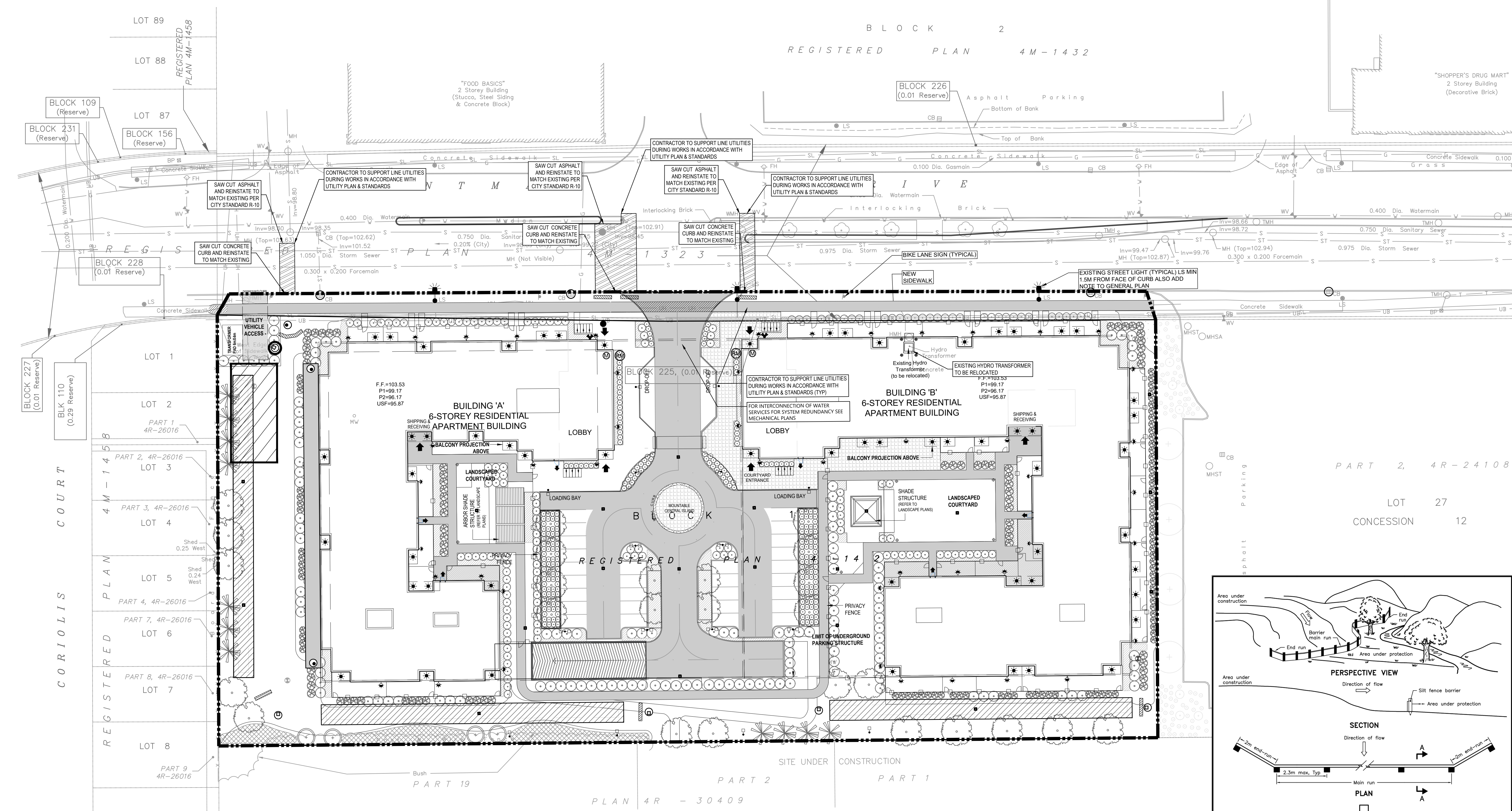

**NOTES:**

- THE CONTRACTOR SHALL IMPLEMENT BEST MANAGEMENT PRACTICES, TO PROVIDE FOR PROTECTION OF THE AREA DRAINAGE SYSTEM AND THE RECEIVING WATERCOURSE, DURING CONSTRUCTION ACTIVITIES. THE CONTRACTOR ACKNOWLEDGES THAT FAILURE TO IMPLEMENT APPROPRIATE EROSION AND SEDIMENT CONTROL MEASURES MAY BE SUBJECT TO PENALTIES IMPOSED BY ANY APPLICABLE REGULATORY AGENCY.
- SILT FENCE TO BE ERRECTED PRIOR TO EARTH WORKS BEING COMMENCED. SILT FENCE TO BE MAINTAINED UNTIL VEGETATION IS ESTABLISHED OR UNTIL START OF SUBSEQUENT PHASE.
  - STRAW BALE SEDIMENT TRAPS TO BE CONSTRUCTED IN EXISTING ROAD SIDE DITCHES. TRAPS TO REMAIN AND BE MAINTAINED UNTIL VEGETATION IS ESTABLISHED.
  - SILT SACK TO BE PLACED AND MAINTAINED UNDER COVER OF ALL CATCHBASINS. GEOTEXTILE SILT SACK IN STREET C&S TO REMAIN UNTIL ALL CURBS ARE CONSTRUCTED. ALL CATCHBASINS TO BE REGULARLY INSPECTED AND CLEANED, AS NECESSARY, UNTIL SOD AND CURBS ARE CONSTRUCTED.
  - CONTRACTOR TO PROVIDE DETAILS ON LOCATION(S) AND DESIGN OF DEWATERING TRAP(S) PRIOR TO COMMENCING WORK. CONTRACTOR ALSO RESPONSIBLE FOR MAINTAINING TRAP(S) AND ADJUSTING SIZE(S) IF DEEMED REQUIRED BY THE ENGINEER DURING CONSTRUCTION. ALL DEWATERING EFFLUENT TO BE DISCHARGED TO EXISTING STORM SEWER SYSTEM.
  - WORKS NOTED ABOVE ARE TO BE INSTALLED, INSPECTED, MAINTAINED AND ULTIMATELY REMOVED BY SERVICING CONTRACTOR. EROSION AND SEDIMENT CONTROL MEASURES TO BE INSPECTED FOLLOWING EACH RAINFALL EVENT.
  - THIS IS A "LIVING DOCUMENT" AND MAY BE MODIFIED IN THE EVENT THE PROPOSED CONTROL MEASURES ARE INSUFFICIENT

- LIGHT DUTY SILT FENCE AS PER OPSD-219.110
- SNOW FENCE
- STRAW BALE CHECK DAM AS PER OPSD-219.180
- ROCK CHECK DAM AS PER OPSD-219.210
- SILT SACK PLACED UNDER EXISTING CB COVER
- TEMPORARY MUD MAT 0.15m THICK 50mm CLEAR STONE ON NON WOVEN FILTER CLOTH

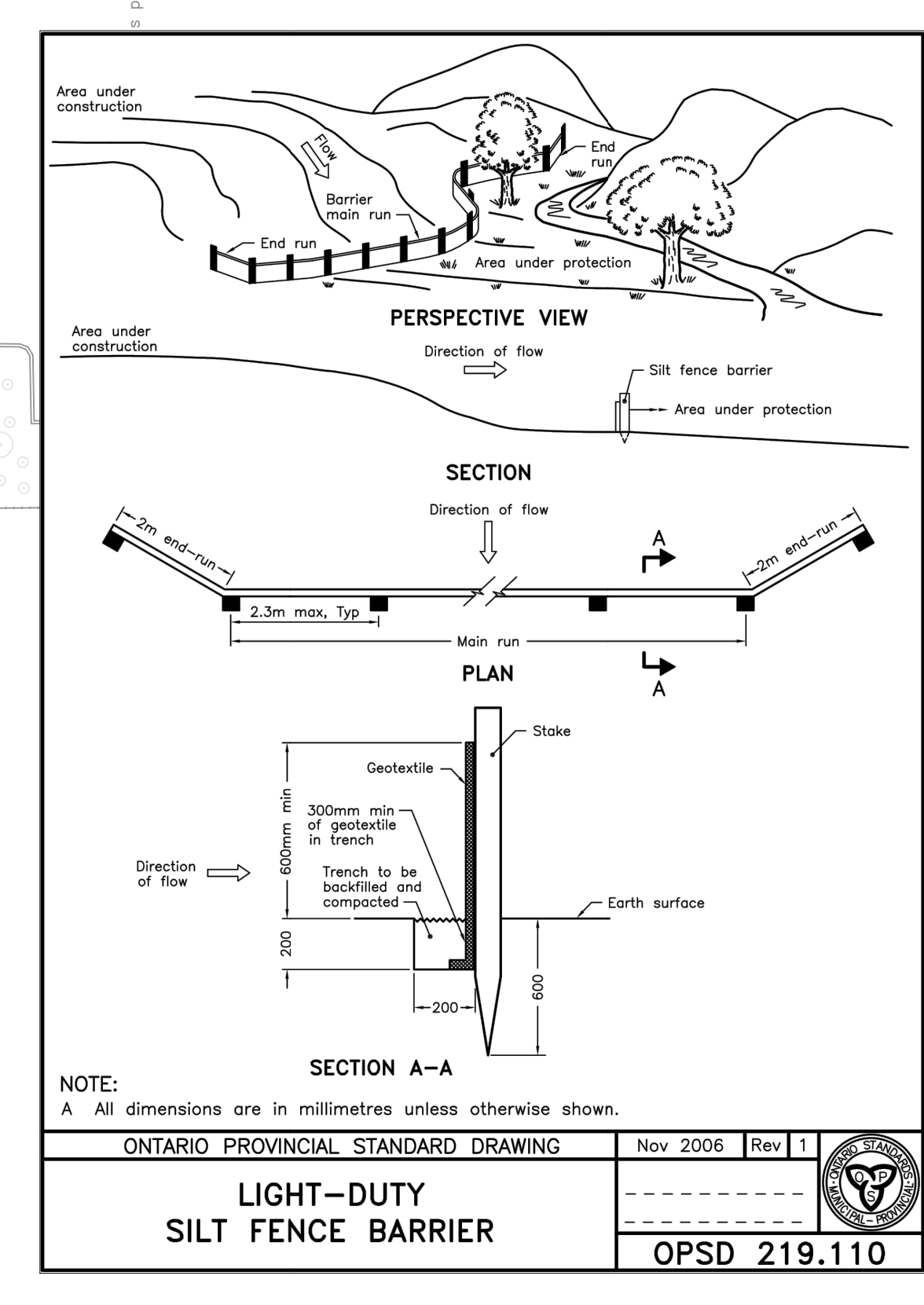

**NOTE:**  
A All dimensions are in millimetres unless otherwise shown.

ONTARIO PROVINCIAL STANDARD DRAWING Nov 2006 Rev 11

**LIGHT-DUTY SILT FENCE BARRIER**

OPSD 219.110

CITY FILE No. D07-12-21-0035  
File Location: \\127134\_21\_huntmar\7\_0\_Production\02\_Design\04\_Civil\Sheets\C-900.dwg Last Saved: June 30, 2021, by: Ehenne Printed: Monday, July 5, 2021 1:22:08 PM by: Eric Henne



## Demetrius Yannoulopoulos

---

**From:** Doug Nuttall <dnuttall@mvc.on.ca>  
**Sent:** Friday, June 22, 2012 9:10 AM  
**To:** Demetrius Yannoulopoulos  
**Cc:** sean.moore@ottawa.ca  
**Subject:** RE: Infiltration augmentation

Sorry about the delay;

MVC is satisfied with this approach. It is reasonable to expect that there will be sufficient infiltration from this facility to supplement the infiltration that will come from the sand beds and irrigation. It would be very interesting to monitor the water flowing into and out of such a facility, and I would ask the consultant, on behalf of the client, if MVC would be able to install monitoring in MH 35? Ideally, we should be monitoring flows in and out of the facility – thus it would be easier for us if the outlet was directed to CBMH 29, rather than directly to the pipe. There should be lots of grade to make that work.

Douglas Nuttall, P.Eng.  
Water Resources Engineer  
Mississippi Valley Conservation

---

**From:** Demetrius Yannoulopoulos  
**Sent:** Tuesday, June 19, 2012 10:03 AM  
**To:** 'Doug Nuttall'  
**Subject:**

Hi Doug

As discussed yesterday, we propose to add a drywell in front of Box C, within in the parking lot area. The drywell will be a clear stone facility 4m wide by 40m long, and 0.73m clear depth from bottom of perforated pipe. The drywell has a total volume of 116.6m<sup>3</sup>, with 30% voids in the clear stone there is 35m<sup>3</sup> of storage available. Rainfall from the 5992 m<sup>2</sup> roof of Box C will supply the drywell, the roof of Box C has flow restrictors limiting the outflow to 25l/s. The dry well is set up such that if the volume of runoff from the roof exceeds the storage capacity of the dry well excess runoff is discharged to the storm sewer, see attached PDF illustrating the proposed drywell.

Rainfall data (see attached) indicates for the months of March up to and including November, 40 days of 5mm or more rain occurred, and for the same period 22 days of 10mm or more rain occurred. Assuming 80% of rainfall is collected by the roof drains the following volume of rainfall is collected and discharged into the drywell:

5mm, at 80% = 4mm, for 5992m<sup>2</sup> roof = 23.96m<sup>3</sup>, for 40 events = 958.72m<sup>3</sup>

10mm, at 80%= 8mm (less 4mm from above) = 4mm for 5992m<sup>2</sup> roof = 23.96m<sup>3</sup>, for 22 events = 527.29m<sup>3</sup>

These events provide a approximately of 1486m<sup>3</sup> of rainfall for use by the drywell.

For the 84,600m<sup>2</sup> site, this will add approximately 17.56mm/yr of infiltration.

As we had previously discussed the sand well will provide approximately 20mm/yr of infiltration with natural rainfall, and the irrigation system will also supplement with an additional 20mm/yr.

Combining these three the site will have approximately 57mm/yr of infiltration which falls within the 50 to 70mm/yr target for this area.

As you are aware the City is asking us to provide CA acceptance of the infiltration approach. If you are in agreement with the above, it would be greatly appreciated if you could forward me an email indicating MVCA acceptance of the infiltration approach.

If you have any questions, please call or email.

Thx

Demetrius

**Demetrius Yannoulopoulos P.Eng.**  
Associate Director

**IBI Group**  
400-333 Preston Street  
Ottawa ON K1S 5N4 Canada

**tel** 613 225 1311 ext 590

**fax** 613 225 9868

**cell** 613 447 0504

**email** [dyannoulopoulos@IBIGroup.com](mailto:dyannoulopoulos@IBIGroup.com)

**web** [www.ibigroup.com](http://www.ibigroup.com)

NOTE: This e-mail message and attachments may contain privileged and confidential information. If you have received this message in error, please immediately notify the sender and delete this e-mail message.

NOTE: Ce courriel peut contenir de l'information privilégiée et confidentielle. Si vous avez reçu ce message par erreur, veuillez le mentionner immédiatement à l'expéditeur et effacer ce courriel.



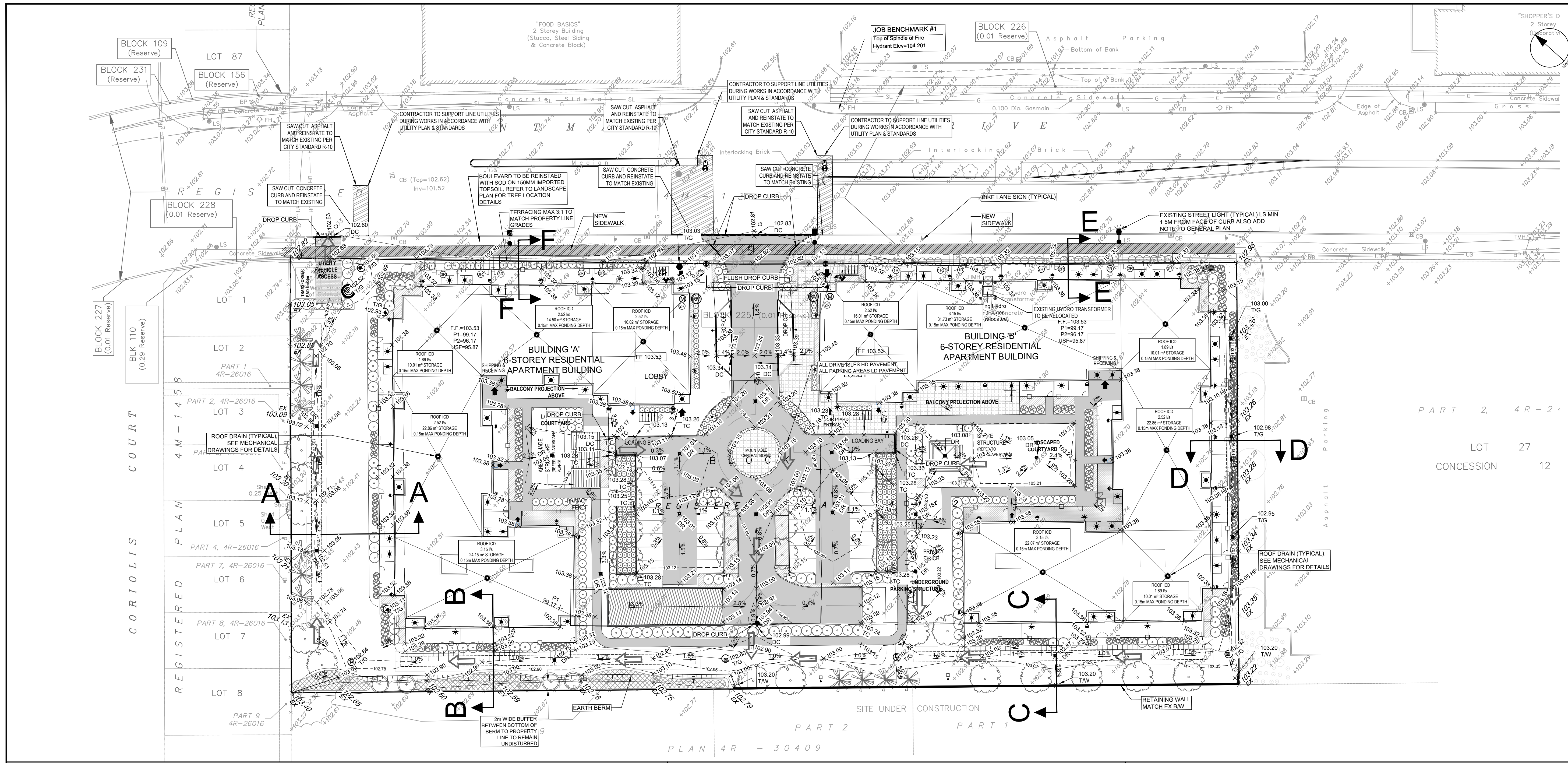

CLIENT

2851 John Street, Suite One, Markham, Ontario L3R 5R7 T 905-968-3185

**COPYRIGHT**  
 This drawing has been prepared solely for the intended use. Any reproduction or distribution for any purpose other than that authorized by IBI Group is forbidden. Written dimensions shall have precedence over scaled dimensions. Contractors shall verify and be responsible for all dimensions and conditions on the job, and IBI Group shall be informed of any variations from the dimensions and conditions shown on the drawing. Shop drawings shall be submitted to IBI Group for general conference before proceeding with fabrication.

IBI Group Professional Services (Canada) Inc.  
 is a member of the IBI Group of companies.

| ISSUES | No. | DESCRIPTION    | DATE       |
|--------|-----|----------------|------------|
|        | 1   | ISSUED FOR SPA | 2021/02/16 |
|        | 2   | SPA SUBMISSION | 2021       |

**NOT FOR CONSTRUCTION**

FOR NOTES, LEGEND

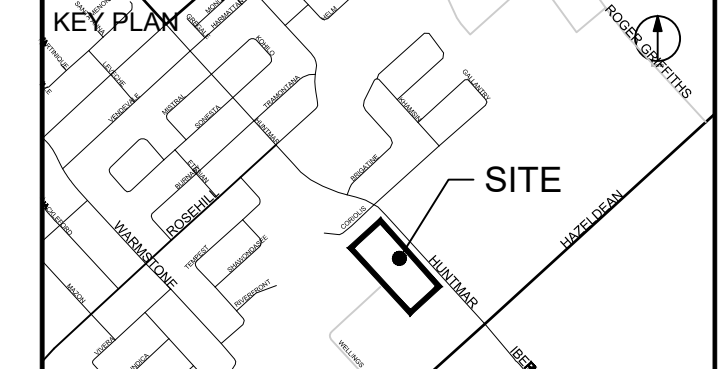

CONSULTANTS

Project Coordinator:  
 North American Development Group

Architect:  
 RLA Architecture

Surveyor:  
 Fairhall, Moffatt and Woodland Ltd.

Geotechnical:  
 Paterson Group

Traffic:  
 JD Halpenny & Assoc.

Electrical:  
 Hammerschlag & Joffe Inc.

Landscape:  
 NAK Design Strategies

SEAL

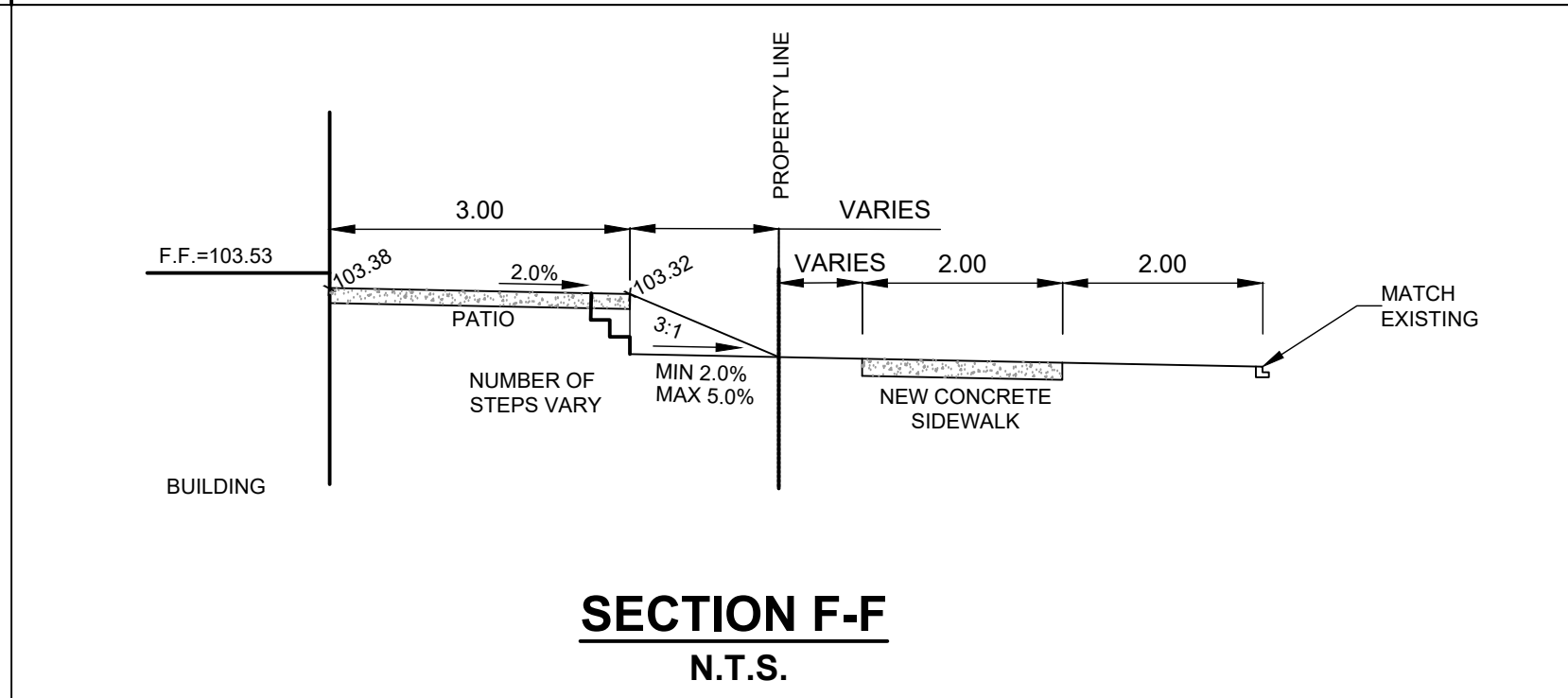
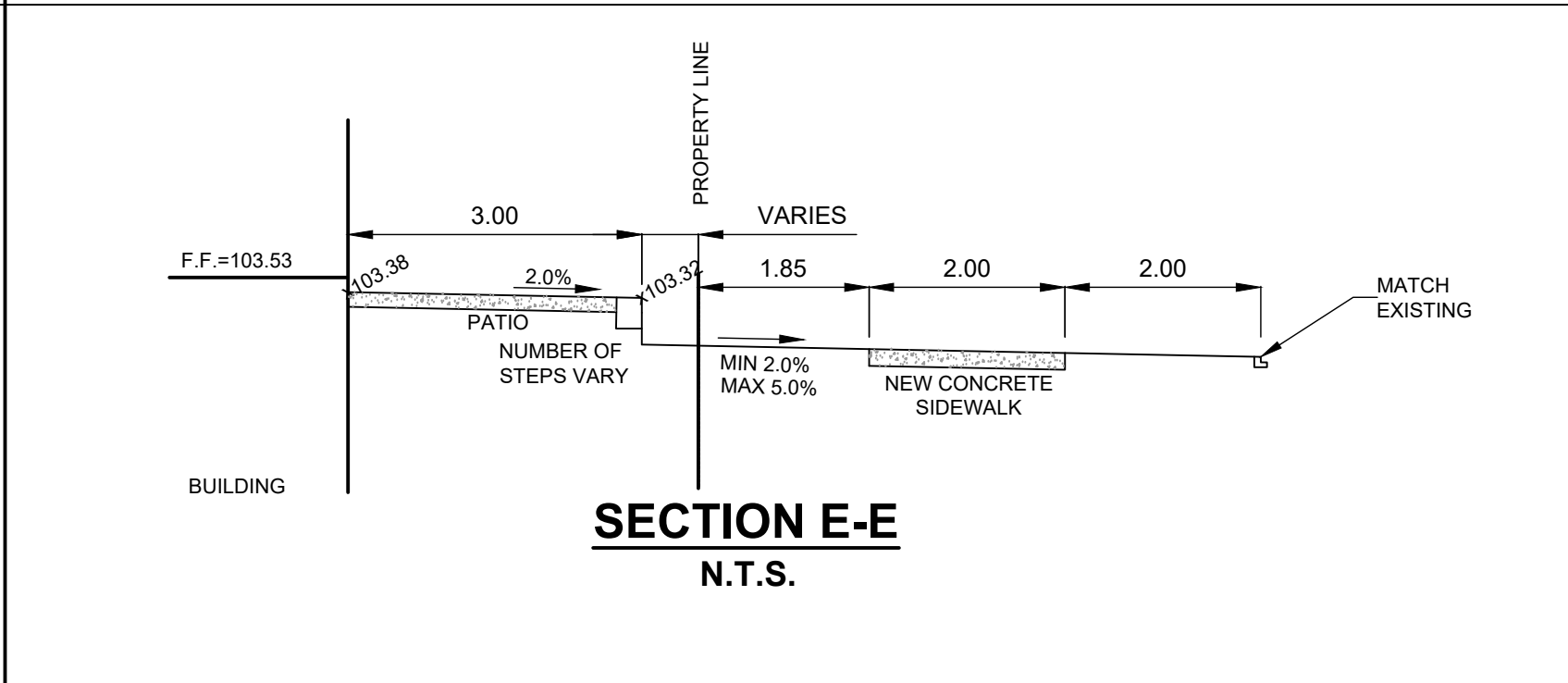
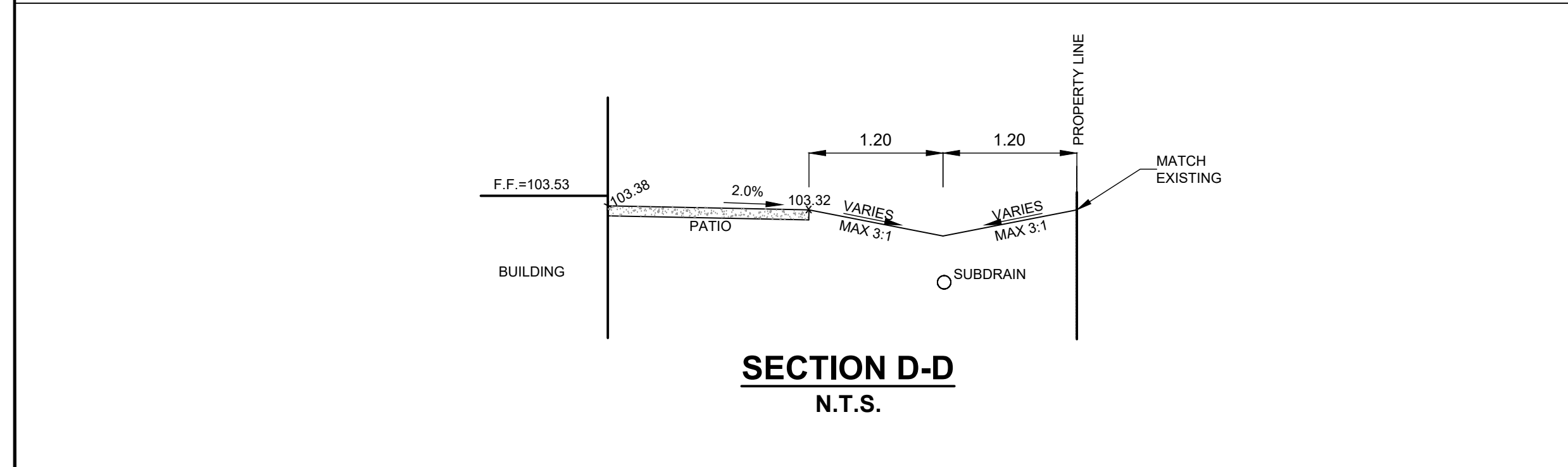
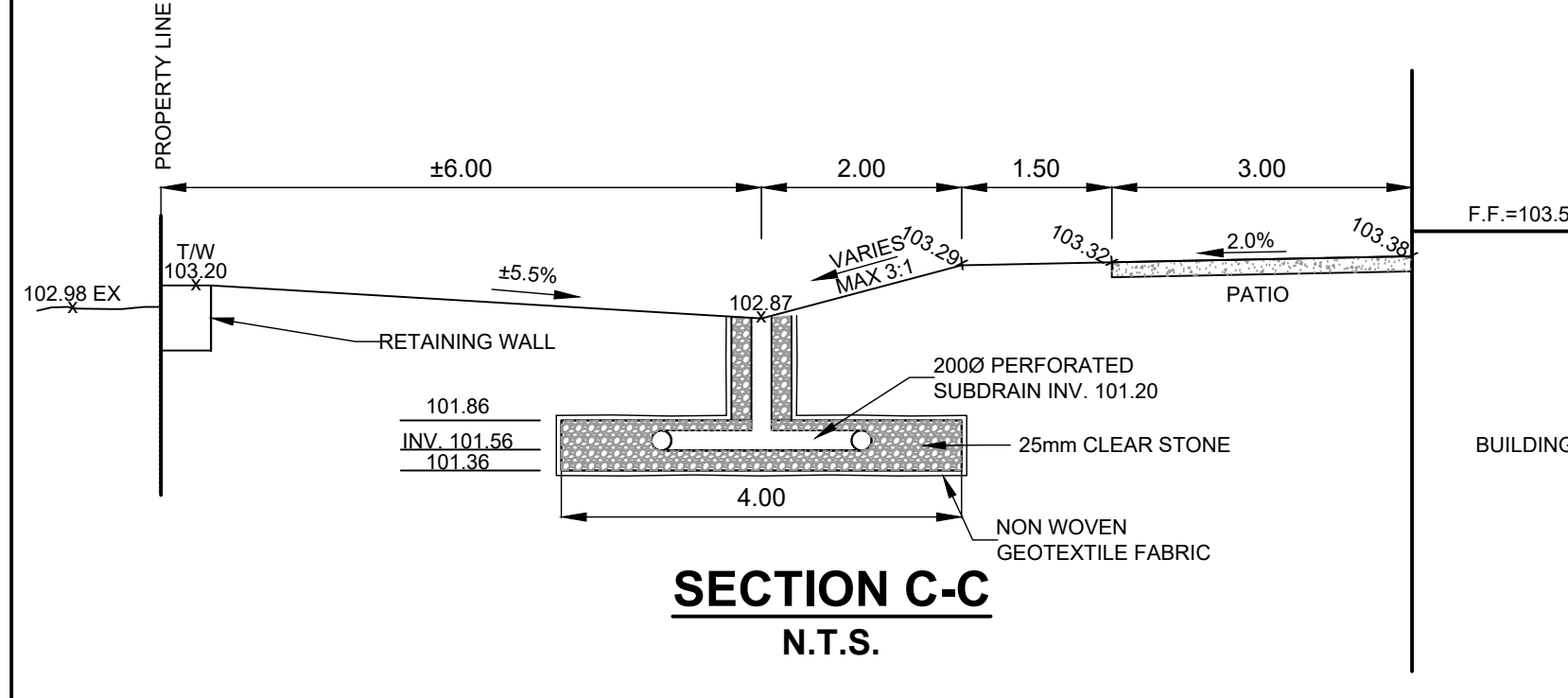
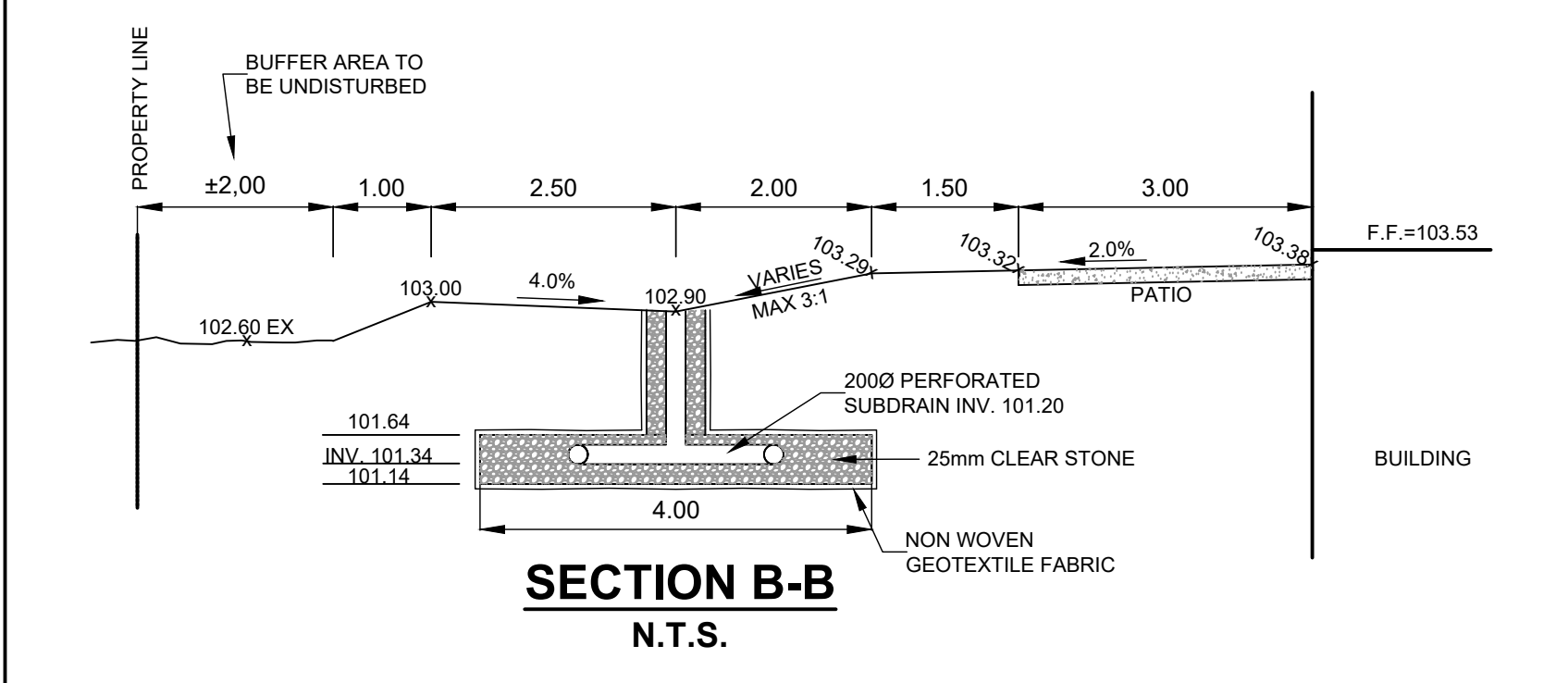
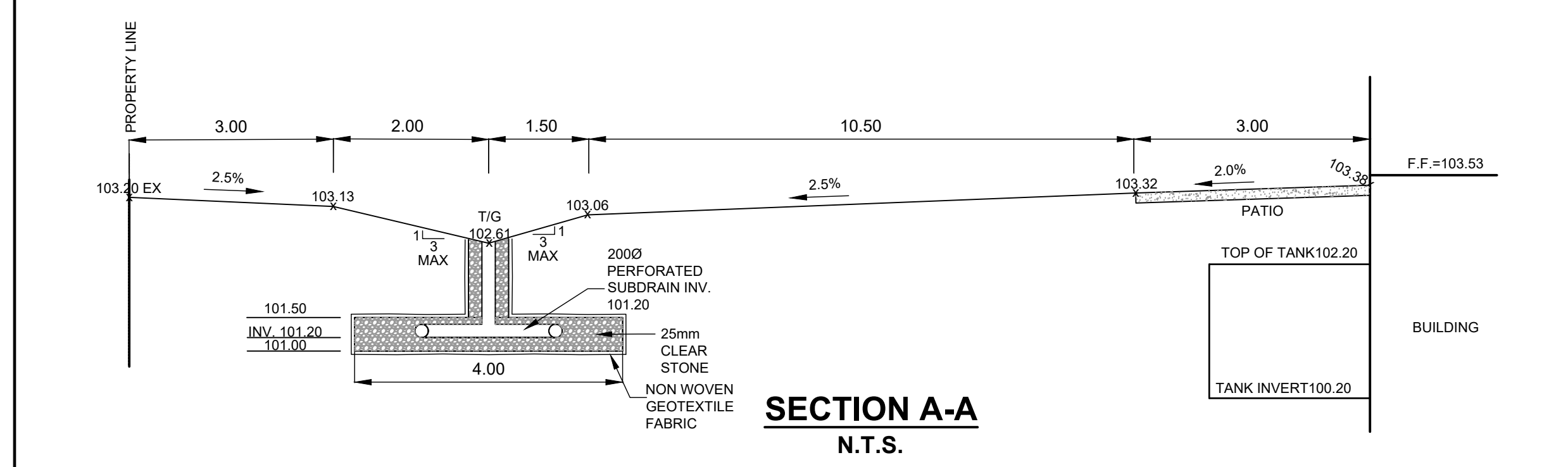

**IBI GROUP**  
 Suite 400 - 333 Preston Street  
 Ottawa ON K1S 5N4 Canada  
 Tel: 613 225 1311 | 613 241 3300 fax 613 225 9868  
 ibigroup.com

PROJECT  
**21/35 HUNTMAR DRIVE**

PROJECT NO:  
**127134**

DRAWN BY:  
**EH**

PROJECT MGR:  
**DGY**

CHECKED BY:  
**DGY**

APPROVED BY:  
**DGY**

SHEET TITLE  
**GRADING PLAN**

SHEET NUMBER  
**C-200**

ISSUE  
**1**

File Location: \\172134\_21\_huntmar\0\_Production\02\_Design\04\_Civil\Sheets\C-200 GRADING PLAN.dwg Last Saved: July 5, 2021, 11:14:14 AM by Eric Henne  
 SCALE CHECK  
 CITY FILE No. D07-12-21-0035  
 CITY PLAN No. 18424