

KINGSETT CAPITAL

**LOT-B RESIDENTIAL DEVELOPMENT, 100  
BAYSHORE DR. OTTAWA, ON  
SITE SERVICING REPORT**

DECEMBER 21, 2021



**wsp**





**LOT-B RESIDENTIAL  
DEVELOPMENT, 100 BAYSHORE  
DR. OTTAWA, ON  
SITE SERVICING REPORT**

**KINGSETT CAPITAL**

FOR SITE PLAN APPROVAL

PROJECT NO.: 211-02810-00  
DATE: DECEMBER 2021

WSP  
2611 QUEENSVIEW DRIVE, SUITE 300  
OTTAWA, ON, CANADA, K2B 8K2

WSP.COM







December 21, 2021

KSGR Bayshore Ottawa Limited GP Inc. c/o KingSett Capital  
40 King Street West, Suite 3700, PO Box 110  
Toronto, ON M5H 3Y2

**Attention: Mark Garber**

Dear Sir:

**Subject:** 100 Bayshore Drive, Ottawa, ON – Site Servicing and Stormwater Management Report

Please find attached our site servicing report issued for site plan approval application, revised for City comments.

Yours sincerely,

A handwritten signature in blue ink, appearing to read 'smc', written over a light blue rectangular background.

Stephen McCaughey, P.Eng., PMP  
Project Engineer

WSP ref.: 211-02810-00



# QUALITY MANAGEMENT

ISSUE/REVISION	FIRST ISSUE	REVISION 1	REVISION 2	REVISION 3
Remarks	Issued for Site Plan Approval Application	Issued for Site Plan Approval Application Rev. 1	Issued for Site Plan Approval Application Rev. 2	Issued for Site Plan Approval Application Rev. 3
Date	2021-04-28	2021-07-26	2021-09-17	2021-12-21
Prepared by	Stephen McCaughey, P.Eng.	Stephen McCaughey, P.Eng.	Stephen McCaughey, P.Eng.	Stephen McCaughey, P.Eng.
Signature				
Checked by	James Johnston, P.Eng.	Ishaque Jafferjee, P.Eng.	Ishaque Jafferjee, P.Eng.	Ishaque Jafferjee, P.Eng.
Signature				
Authorised by				
Signature				
Project number	211-02810-00	211-02810-00	211-02810-00	211-02810-00
Report number				
File reference				



---

# SIGNATURES

PREPARED BY



---

Stephen McCaughey, P.Eng.  
Project Engineer

REVIEWED BY



---

Ishaque Jafferjee, P.Eng.  
Senior Project Engineer

This report was prepared by WSP Canada Inc. for the account of KingSett Capital, in accordance with the professional services agreement. The disclosure of any information contained in this report is the sole responsibility of the intended recipient. The material in it reflects WSP Canada Inc.'s best judgement in light of the information available to it at the time of preparation. Any use which a third party makes of this report, or any reliance on or decisions to be made based on it, are the responsibility of such third parties. WSP Canada Inc. accepts no responsibility for damages, if any, suffered by any third party as a result of decisions made or actions based on this report. This limitations statement is considered part of this report.

The original of the technology-based document sent herewith has been authenticated and will be retained by WSP for a minimum of ten years. Since the file transmitted is now out of WSP's control and its integrity can no longer be ensured, no guarantee may be given with regards to any modifications made to this document.



# TABLE OF CONTENTS

<b>1</b>	<b>INTRODUCTION .....</b>	<b>1</b>
<b>1.1</b>	<b>Executive Summary .....</b>	<b>1</b>
<b>1.2</b>	<b>Location Map and Plan .....</b>	<b>2</b>
<b>1.3</b>	<b>Higher Level Studies.....</b>	<b>2</b>
<b>1.4</b>	<b>Available Existing and Proposed Infrastructure.....</b>	<b>3</b>
<b>1.5</b>	<b>Geotechnical Study .....</b>	<b>3</b>
<b>2</b>	<b>WATER DISTRIBUTION .....</b>	<b>4</b>
<b>2.1</b>	<b>System Constraints and Boundary Conditions .....</b>	<b>4</b>
<b>2.2</b>	<b>Confirmation of Adequate Domestic Supply and Pressure.....</b>	<b>4</b>
<b>2.3</b>	<b>Confirmation of Adequate Fire Flow Protection .....</b>	<b>5</b>
<b>3</b>	<b>WASTEWATER DISPOSAL.....</b>	<b>6</b>
<b>3.1</b>	<b>Design Criteria.....</b>	<b>6</b>
<b>3.2</b>	<b>Calculations for Sanitary Demand.....</b>	<b>6</b>
<b>3.3</b>	<b>Verification of Available Capacity in Existing Sewer .....</b>	<b>6</b>
<b>4</b>	<b>SITE STORM SERVICING.....</b>	<b>7</b>
<b>4.1</b>	<b>Existing Condition.....</b>	<b>7</b>
<b>4.2</b>	<b>Drainage Drawings .....</b>	<b>7</b>
<b>4.3</b>	<b>Water Quantity Control Objective .....</b>	<b>7</b>
<b>4.4</b>	<b>Water Quality Control Objective .....</b>	<b>7</b>
<b>4.5</b>	<b>Proposed Minor System .....</b>	<b>7</b>
<b>4.6</b>	<b>Proposed Major System.....</b>	<b>7</b>
<b>5</b>	<b>SEDIMENT AND EROSION CONTROL.....</b>	<b>8</b>
<b>5.1</b>	<b>General .....</b>	<b>8</b>



<b>6</b>	<b>APPROVAL AND PERMIT REQUIREMENTS .....</b>	<b>10</b>
<b>6.1</b>	<b>General .....</b>	<b>10</b>
<b>7</b>	<b>CONCLUSION CHECKLIST.....</b>	<b>11</b>
<b>7.1</b>	<b>Conclusions and Recommendations.....</b>	<b>11</b>
<b>7.2</b>	<b>Comments Received from Review Agencies.....</b>	<b>11</b>



---

## **TABLES**

TABLE 2-1:	BOUNDARY CONDITIONS (CITY OF OTTAWA).....	4
TABLE 2-2:	SUMMARY OF WATER PRESSURE FROM EPANET RESULTS.....	5

---

## **FIGURES**

FIGURE 1-1	SITE LOCATION.....	2
------------	--------------------	---

---

## **APPENDICES**

<b>A</b>	WATER DEMAND
<b>B</b>	SANITARY DEMAND
<b>C</b>	SITE DRAWINGS
<b>D</b>	STORM SEWER DESIGN SHEET
<b>E</b>	CORRESPONDENCES



# 1 INTRODUCTION

---

## 1.1 EXECUTIVE SUMMARY

WSP was retained by KingSett Capital to provide servicing, grading and stormwater management design services in support of the site plan approval for the proposed residential development located at 100 Bayshore Dr. Lot B, in the City of Ottawa. The proposed work consists of two residential high-rise towers connected by an above-ground parking podium. This report will provide sufficient detail to demonstrate that the proposed development can be supported by the existing municipal infrastructure services (watermain, sanitary and storm sewers) and that the servicing design conforms to the applicable standards and guidelines. The report will also include measures to be taken during the construction to minimize erosion and sedimentation. A separate report (100 Bayshore Dr. – Stormwater Management Report) is provided detailing the stormwater management approach and addressing the quantity control and quality measures in accordance with the applicable guidelines.

Currently, the site is an open grassed area with a small array of trees. The southeast corner of the lot has an existing pedestrian bridge between the Bayshore Shopping Centre and the Bayshore Transit Station. The total property area is 6,743 m<sup>2</sup> in size. The site is bounded by undeveloped land to the west, the transit station to the south, Woodridge Crescent to the north, and transit/shopping centre access road to the east.

The subject site is a single property with easements for Hydro along the west and north edges. There is also an allowance for a multi-use pathway (MUP) that will run along the south and east edges of the site. The site generally slopes away from the centre outwards to the four sides. The site is serviced for water (which will be replaced) but not sanitary, and there are some minor storm sewers on site which will be demolished.

The City of Ottawa requires that the design of a drainage and stormwater management system in this development must be prepared in accordance with the following documents:

- Sewer Design Guidelines, City of Ottawa, October 2012;
- Stormwater Management Planning and Design Manual, Ministry of the Environment, March 2003; and
- Stormwater Management Facility Design Guidelines, City of Ottawa, April 2012

This report was prepared utilizing servicing design criteria obtained from the City of Ottawa and outlines the design for water, sanitary wastewater and stormwater facilities.

The format of this report matches that of the servicing study checklist found in Section 4 of the City of Ottawa's Servicing Study Guidelines for Development Applications, November 2009.

The following municipal services are available within Woodridge Cres. adjacent to the development as recorded from the following as-built drawings received from the City:

Woodridge Cres.

- ▶ 203 mm PVC watermain, 250 mm concrete sanitary sewer and 675 mm concrete stormwater sewer.

It is proposed that an on-site stormwater management system will be provided to collect and attenuate flow rates leaving the site. Refer to stormwater management report for details.



---

## **1.4 AVAILABLE EXISTING AND PROPOSED INFRASTRUCTURE**

As described above, all municipal mains (sanitary, storm and watermain) are available and located along Woodridge Crescent. Valved water servicing will be provided as well as sanitary servicing with monitoring hole at or near the property line. Quantity and quality control is required to restrict the stormwater discharge leaving the site, thus the on-site storm runoff will be captured, detention storage provided, flow release restricted, treated for quality control requirements, and finally directed towards the existing storm sewer on Woodridge Crescent.

---

## **1.5 GEOTECHNICAL STUDY**

Golder provided a geotechnical investigation report of the subject property dated March 2021. The site consists of topsoil overtop granular fill (between 0.8-2.4m below grade) overtop clay/silt (down to depths of about 3.8-7.6m). Based on the report, groundwater was measured between 2.7-5.6 m below grade and bedrock well below grade (around 32m below grade). The recommendations of the report have been taken into account for this design development.

## 2 WATER DISTRIBUTION

### 2.1 SYSTEM CONSTRAINTS AND BOUNDARY CONDITIONS

Boundary conditions have been provided by the City of Ottawa at the existing connection along the Woodridge Cres. 203mm watermain (Zone 1W).

**Table 2-1: Boundary Conditions (City of Ottawa)**

Scenario	Woodridge Cres. Connection
Average Day (MAX HGL)	115.2m
Peak Hour (MIN HGL)	106.3m
Max Day + Fire Flow	82.5m

### 2.2 CONFIRMATION OF ADEQUATE DOMESTIC SUPPLY AND PRESSURE

Water demands are based on Table 4.2 of the Ottawa Design Guidelines – Water Distribution for these residential demands based on the number of apartment units. For purpose of verification of supply, the full buildout (both towers) have been assumed. A water demand calculation sheet is included in Appendix A, and the total water demands are summarized as follows:

	West Tower	East Tower	<b>Total</b>
Average Day	1.35 L/s	1.52 L/s	<b>2.86 L/s</b>
Maximum Day	3.38 L/s	3.77 L/s	<b>7.15 L/s</b>
Peak Hour	7.44 L/s	8.28 L/s	<b>15.72 L/s</b>

Since the average day demand is greater than 50,000 L/d (0.58 L/s), twin 150mm services will be provided from Woodridge Cres. to the building, as shown in the site servicing drawing in Appendix C.

The pressure criteria identified in the guidelines are as follows:

Minimum Pressure	Minimum system pressure under peak hour demand conditions shall not be less than 276 kPa (40 psi)
Fire Flow	During the period of maximum day demand, the system pressure shall not be less than 140 kPa (20 psi) during a fire flow event.
Maximum Pressure	Maximum pressure at any point the distribution system shall not exceed 689 kPa (100 psi). In accordance with the Ontario Building/Plumbing Code, the maximum pressure should not exceed 552 kPa (80 psi). Pressure reduction controls may be required for buildings where it is not possible/feasible to maintain the system pressure below 552 kPa.

The site has been analyzed as summarized below and in Table 2-2 to ensure all the City of Ottawa minimum criteria for water pressures are met for the two conditions (maximum day + fire flow and peak hour). The analysis was carried out using

EPANET, hydraulic and water quality analysis based on the boundary conditions provided by the City of Ottawa. The detailed EPANET output results are also included in the Appendix B.

With respect to a max day + fire flow of 140.48 L/s, the model indicated that the pressure drop in the pipe was acceptable and within the City of Ottawa’s minimum pressure requirements. Section 2.3 following details the fire flow estimation.

With respect to a peak hour demand of 15.72 L/s, the model indicated that the pressure drop in the pipe was also acceptable and within the City of Ottawa’s minimum pressure requirements.

Refer to Appendix B for the detailed water distribution analysis output.

**Table 2-2: Summary of Water Pressure from EPANET results**

Scenario	Pressure at Building Connection	
	(psi)	(kPa)
Max Day + Fire Flow	21	145
Peak Hour (MIN HGL)	60	414
Average Day (Max HGL)	73	502

## 2.3 CONFIRMATION OF ADEQUATE FIRE FLOW PROTECTION

The fire flow rate has been calculated using the Fire Underwriters Survey (FUS) method. The method takes into account the type of building construction, the building occupancy, the use of sprinklers and the exposures to adjacent structures. For fire resistive construction with a full sprinkler system only the first four largest floors are taken into account, leading to the calculated fire flow demand of 8,000 L/min (133 L/s). A copy of the FUS calculations are included in Appendix A along with a letter from the Architect which supports the designation “fire resistive construction”. The calculations, including the letter from the Architect, were provided originally with the Adequacy of Services Report in support of the Re-Zoning Application.

The maximum fire demand of 8,000 L/min can be delivered through the proposed twin 150mm services. Further, there is one Class AA fire hydrant within 75m of the building and two Class AA fire hydrants with 150m of the building along the same side of Woodridge Cres. capable of providing total 13,248 L/min per City of Ottawa Technical Bulletin ISTB-2018-02. The nearest hydrant is within 45m of the buildings’ fire department connections. See Appendix A for distance to nearest hydrants on south side of Woodridge Cres. to centre of site entrance plus approximately 25 m to the buildings.

The boundary condition for Maximum Day and Fire Flow results in a pressure of 145 kPa at the building. In the guidelines, a minimum residual pressure of 140 kPa must be maintained in the distribution system for a fire flow and maximum day event; therefore, the fire flow requirement is met.

## 3 WASTEWATER DISPOSAL

---

### 3.1 DESIGN CRITERIA

In accordance with the City of Ottawa’s Sewer Design Guidelines, the following design criteria have been utilized in order to estimate wastewater flows generated by the subject site and verify existing capacity;

- Average sanitary flow for residential use 280 L/c/d
  - Gross area Residential use 0.6
  - Infiltration & Foundation Allowance (Total) 0.33 L/ha/s
- 

### 3.2 CALCULATIONS FOR SANITARY DEMAND

The criteria to determine anticipated peak flow based on site used as described in Ottawa Sewer Design Guidelines Appendix 4-A are as follows, refer to appendix C for detailed calculation. Since the building size and lot zoning is not changing, from a capacity verification standpoint there isn’t a difference considered for current demand estimate to post-refit demand estimate. Detailed calculations are provided in Appendix C.

	West Tower	East Tower	<b>Total</b>
Average Day	1.35 L/s	1.51 L/s	<b>2.86 L/s</b>
Peak	4.61 L/s	5.11 L/s	<b>2.86 L/s</b>
Extraneous Day	0.10 L/s	0.10 L/s	<b>0.20 L/s</b>
Total	4.71 L/s	5.21 L/s	<b>9.92 L/s</b>

---

### 3.3 VERIFICATION OF AVAILABLE CAPACITY IN EXISTING SEWER

The sanitary demand will be serviced by a 150mm sewer with a minimum slope of 1% to the 250mm sewer on Woodridge Crescent, on a proposed maintenance hole installed on the existing sewer. A Sanitary Sewer Design Sheet is provided in Appendix B confirming capacity and minimum scouring velocity is achieved. Further, per communication with the City provided in Appendix F, the existing downstream sewer has sufficient capacity for the estimated peak flow.



## 4 SITE STORM SERVICING

---

### 4.1 EXISTING CONDITION

The subject site is located on the south side of Woodridge Crescent, west of the Bayshore Shopping Centre and north of the Bayshore Transit Station, currently undeveloped with grass, shrub and tree growth. The site contains some storm infrastructure (pipes, maintenance holes, catch basins) that will be removed/abandoned as part of the development. The storm sewer entering the site at the southwest is abandoned as part of the Phase 2 LRT Expansion. Likewise the MUP and lands between the MUP and Bayshore Transit Station are being accounted for as part of the Phase 2 LRT Expansion to be controlled by the Bayshore Transit Station. Most runoff from the subject site is ultimately directed to 675 mm diameter trunk storm sewer, which runs from east to west along Woodridge Cres.

---

### 4.2 DRAINAGE DRAWINGS

Site drawings are included in Appendix C including removals, servicing, grading, drainage area, and erosion and sediment control. The drainage areas and grades have been coordinated with the adjacent LRT Expansion project to ensure drainage from the MUP inwards is retained on this property and the Bayshore Transit Station lands retain their drainage.

---

### 4.3 WATER QUANTITY CONTROL OBJECTIVE

Refer to the Stormwater Management Report for the water quantity objective for the site.

---

### 4.4 WATER QUALITY CONTROL OBJECTIVE

Refer to the Stormwater Management Report for the water quality objective for the site.

---

### 4.5 PROPOSED MINOR SYSTEM

The development will be serviced by 375 mm storm service connection with a proposed maintenance hole on the existing 675 mm storm sewer on Woodridge Crescent. Runoff from the new development area of the site will be collected by a network of roof drains, surface inlets and storm sewers. All controlled storm runoff will be directed to a cistern located within the building footprint. The cistern will be complete with sump pumps (backed up by the building generator) to discharge at the fixed rate of 20 L/s a flow control valve, per the Stormwater Management Report, to the oil grit separator. The cistern has been sized to provide active storage up to the 100-year storm of 240 m<sup>3</sup>, due to space constraints it will extend from the P1 underground level to below the building footing. The sewer and cistern design sheet for the site storm system is provided in Appendix D.

---

### 4.6 PROPOSED MAJOR SYSTEM

The storm sewers are sized such that no ponding will occur during the 2-year, 100-year storm, and 100+20% stress test. The cistern is sized for the 100-year storm, however in cases of overflow the cistern will backflow through STM1 and CB2 and overflow to Woodridge Crescent. The cistern inlets from interior drainage (roof drains, deck drain, CB3) will be complete with check valves to prevent backup into the internal drainage pipes. The lowest elevation of overland flow is through CB2 and out to Woodridge Crescent at an elevation of 66.18m. The major overland flow routes lead out to Woodridge Crescent, with the overflow elevations at the driveway entrances to the ROW at minimum 300mm below the building entrances (66.50m). Additionally, the spillover point is less than 300mm from the catch basin elevation so there will be no ponding greater than 300mm.

## 5 SEDIMENT AND EROSION CONTROL

---

### 5.1 GENERAL

Prior to topsoil stripping, earthworks or underground construction, erosion and sediment controls will be implemented and will be maintained throughout construction. Silt fences will be installed around the perimeter of the site and will be cleaned and maintained throughout construction. Silt fences will remain in place until the working areas have been stabilized or re-vegetated. Catch basins and manholes will have filter fabric installed under the grate during construction to protect from silt entering the storm sewer system. A mud mat will be installed at the construction access to reduce risk of mud tracking onto adjacent roads.

Erosion and sediment controls must be in place during construction. Recommendations to the contractor will be included in the erosion and sediment control plan in Appendix C and are summarized below:

During all construction activities, erosion and sedimentation shall be controlled by the following techniques:

Prior to start of construction:

- ▶ Install silt fence along the perimeter of the property line.
- ▶ Install mud mat (gravel mat on geotextile) at construction site entrance to reduce mud tracking from site onto road.
- ▶ Install filter fabric or silt sack filters in all the catchbasins and manholes that capture runoff from the construction area.

During construction:

- ▶ Minimize the extent of disturbed areas and the duration of exposure and impacts to existing grading.
- ▶ Perimeter vegetation to remain in place until permanent storm water management is in place otherwise, immediately install silt fence when the existing site is disturbed at the perimeter.
- ▶ Protect disturbed areas from overland flow by providing temporary swales to the satisfaction of the field engineer. Tie-in temporary swale to existing catchbasins as required.
- ▶ During demolition of existing on-site storm infrastructure, protect downstream sewers from unfiltered flow.
- ▶ Provide temporary cover such as seeding or mulching if disturbed area will not be rehabilitated within 30 days.
- ▶ Inspect silt fences, filter fabric filters and catch basin sumps weekly and within 24 hours after a storm event. Clean and repair when necessary.
- ▶ Drawing to be reviewed and revised as required during construction.
- ▶ Erosion control fencing to be also installed around the base of all stockpiles.
- ▶ Do not locate topsoil piles and excavation material closer than 2.5m from any paved surface, or one which is to be paved before the pile is removed. All topsoil piles are to be seeded if they are to remain on site long enough for seeds to grow (longer than 30 days).
- ▶ Control dust blown off-site by seeding topsoil piles and other areas temporarily (provide watering as required and to the satisfaction of the engineer).
- ▶ No alternate methods of erosion protection shall be permitted unless approved by the field engineer.

- ▶ City roadway and sidewalk to be cleaned of all sediment from vehicular tracking as required.
- ▶ During wet conditions, tires of all vehicles/equipment leaving the site are to be scrapped.
- ▶ Any mud/material tracked onto the road shall be removed immediately by hand or rubber tire loader.
- ▶ Take all necessary steps to prevent building material, construction debris or waste being spilled or tracked onto abutting properties or public streets during construction and proceed immediately to clean up any areas so affected.
- ▶ All erosion control structure to remain in place until all disturbed ground surfaces have been stabilized either by paving or restoration of vegetative ground cover.
- ▶ During the course of construction, if the engineer believes that additional prevention methods are required to control erosion and sedimentation, the contractor will install additional silt fences or other methods as required to the satisfaction of the engineer.
- ▶ The contractor shall implement best management practices, to provide for protection of the area drainage system and the receiving watercourse, during construction activities. The contractor acknowledges that failure to implement appropriate erosion and sediment control measures may be subject to penalties imposed by any applicable regulatory agency.

## 6 APPROVAL AND PERMIT REQUIREMENTS

---

### 6.1 GENERAL

The proposed development is subject to City of Ottawa site plan approval and criteria from the Rideau Valley Conservation Authority.

No other permits or approvals are anticipated to be required from the Ontario Ministry of the Environment, Conservation and Parks (MECP), Ontario Ministry of Transportation, National Capital Commission, Parks Canada, Public Works and Government Services Canada, or any other provincial or federal regulatory agency except those noted above.

## **7 CONCLUSION CHECKLIST**

---

### **7.1 CONCLUSIONS AND RECOMMENDATIONS**

It is concluded that the proposed development can meet all provided servicing constraints and associated requirements. It is recommended that this report be submitted to the City of Ottawa in support of the application for site plan approval.

---

### **7.2 COMMENTS RECEIVED FROM REVIEW AGENCIES**

Minutes from the pre-consultation meeting held with the City of Ottawa are provided in Appendix E.

# A WATER DEMAND

**WATER DISTRIBUTION - PROPOSED DOMESTIC DEMANDS**

Demand Type	Amount	Units
<b>Average Day Demand</b>		
Residential	= 280	L/c/d
Light Industrial	= 35000	L/gross ha/d
Heavy Industrial	= 55000	L/gross ha/d
Shopping Centres	= 2500	L/(1000m2/d)
Hospitals	= 900	L/(bed/d)
Schools	= 70	L/(Students/d)
Trailer Parks no Hook-Ups	= 340	L/(space/d)
Trailer Parks with Hook-Ups	= 800	L/(space/d)
Campgrounds	= 225	L/(campsite/d)
Mobile Home Parks	= 1000	L/(Space/d)
Motels	= 150	L/(bed-space/d)
Hotels	= 225	L/(bed-space/d)
Tourist Commercial	= 28000	L/gross ha/d
Other Commercial	= 28000	L/gross ha/d

<b>Maximum Daily Demand:</b>			
Residential	=	2.5 x average day	L/c/d
Industrial	=	1.5 x average day	L/gross ha/d
Commercial	=	1.5 x average day	L/gross ha/d
Institutional	=	1.5 x average day	L/gross ha/d

<b>Maximum Hour Demand:</b>			
Residential	=	2.2 x maximum day	L/c/d
Industrial	=	1.8 x maximum day	L/gross ha/d
Commercial	=	1.8 x maximum day	L/gross ha/d
Institutional	=	1.8 x maximum day	L/gross ha/d

Unit Type	Person / Unit
Single Family	3.4
Semi-detached	2.7
Duplex	2.3
Townhouse (row)	2.7
<b>Apartments:</b>	
Bachelor	1.4
1 Bedroom	1.4
2 Bedroom	2.1
3 Bedroom	3.1
Average Apt.	1.8

Population Calculator	East Tower	West Tower
Single Family		
Semi-detached		
Duplex		
Townhouse (row)		
Bachelor		
1 Bedroom	212	190
2 Bedroom	80	72
3 Bedroom		
Average Apt.		
Total Population	<b>465</b>	<b>417</b>

Demand Type =	East Tower		West Tower		Combined Demand
	Residential		Residential		
Average Day Demand =	280	L/c/d	280	L/c/d	
Population =	465		417		
	280 x 465		280 x 417		
	130,144	L/day	116,816	L/day	
<b>Average Daily Flow =</b>	<b>1.51</b>	<b>L/s</b>	<b>1.35</b>	<b>L/s</b>	<b>2.86</b>
Daily Demand Type =	Residential		Residential		
Max. Daily Factor =	2.5	L/c/d	2.5	L/c/d	
	2.5 x Average Daily Flow		2.5 x Average Daily Flow		
	2.5 x 130,144		2.5 x 116,816		
	325,360	L/day	292,040	L/day	
<b>Maximum Daily Demand =</b>	<b>3.77</b>	<b>L/s</b>	<b>3.38</b>	<b>L/s</b>	<b>7.15</b>
Hour Demand Type =	Residential		Residential		
Max. Hour Factor =	2.2	L/c/d	2.2	L/c/d	
	2.2 x Maximum Daily Demand		2.2 x Maximum Daily Demand		
	2.2 x 325,360		2.2 x 292,040		
	715,792	L/day	642,488	L/day	
<b>Maximum Hour Demand =</b>	<b>8.28</b>	<b>L/s</b>	<b>7.44</b>	<b>L/s</b>	<b>15.72</b>

**WATER DISTRIBUTION - PROPOSED FIRE FLOW DEMANDS**

$F = 220 C \sqrt{A}$
----------------------

Type of Construction Coefficient:		Comments
Wood Frame	1.5	(all structurally combustible)
Ordinary	1.0	(brick, masonry wall, combustible floor and interior)
Non-Combustible	0.8	(unprotected metal structural component, masonry or metal walls)
Fire Resistive	0.6	(fully protected frame, floors and roof)

Combustibility:		
Non-Combustible	-25%	
Limited Combustible	-15%	
Combustible	0%	
Free Burning	15%	
Rapid Burning	25%	

Sprinkler Protection:		
Complete Sprinkler System	-50%	(max.)
NFPA 13 Conformed	-30%	(max.)
If Water Supply Standard for Both System and Fire Lines	-10%	additional (max.)
Fully Supervised System	-10%	additional (max.)
None	0%	

	East Tower			West Tower		
Type of Construction Coefficient	Fire Resistive			Fire Resistive		
	0.6			0.6		
Gross Floor Area (m <sup>2</sup> )	10,926 m <sup>2</sup>			10,915 m <sup>2</sup>		
Fire Flow, F	13,798 L/min			13,791 L/min		
F(round)	14,000 L/min			14,000 L/min		
Modification 1: Occupancy Combustibility	Limited Combustible			Limited Combustible		
	-15%			-15%		
Occupancy Credit	-2,100 L/min			-2,100 L/min		
F(mod1) = F(round) + Occupancy Credit	11,900 L/min			11,900 L/min		
Modification 2: Sprinkler Protection	Complete Sprinkler System			Complete Sprinkler System		
	-50%			-50%		
Additional Credit	If Water Supply Standard for Both System and Fire Lines			If Water Supply Standard for Both System and Fire Lines		
	0			0		
Sprinkler Credit	-5,950 L/min			-5,950 L/min		
F(mod2) = F(mod1) + Sprinkler Credit	5,950 L/min			5,950 L/min		
Modification 3: Exposure Distances						
North	>45 m	0%		>45 m	0%	
South	>45 m	0%		>45 m	0%	
East	>45 m	0%		20 m	15%	
West	20 m	15%		>45 m	0%	
	Total % = 15%			Total % = 15%		
	11,900 x 0.15			11,900 x 0.15		
Exposure Credit	1,785 L/min			1,785 L/min		
F(mod3) = F(mod2) + Exposure Credit	7,735 L/min			7,735 L/min		
<b>F(final) = F(mod3) rounded to nearest 1,000L/min</b>	<b>8,000 L/min</b>			<b>8,000 L/min</b>		
<b>F(final)</b>	<b>133 L/s</b>			<b>133 L/s</b>		



	East Tower	West Tower	
<b>Average Daily Demand</b>	1.51	1.35	<b>2.86</b> L/s
<b>Maximum Daily Demand</b>	3.77	3.38	<b>7.15</b> L/s
<b>Peak Hour Demand</b>	8.28	7.44	<b>15.72</b> L/s
<b>Fire Flow</b>	133	133	L/s

**Max Day + Fire Flow** **140.48** L/s

# Boundary Condition for 100 Bayshore

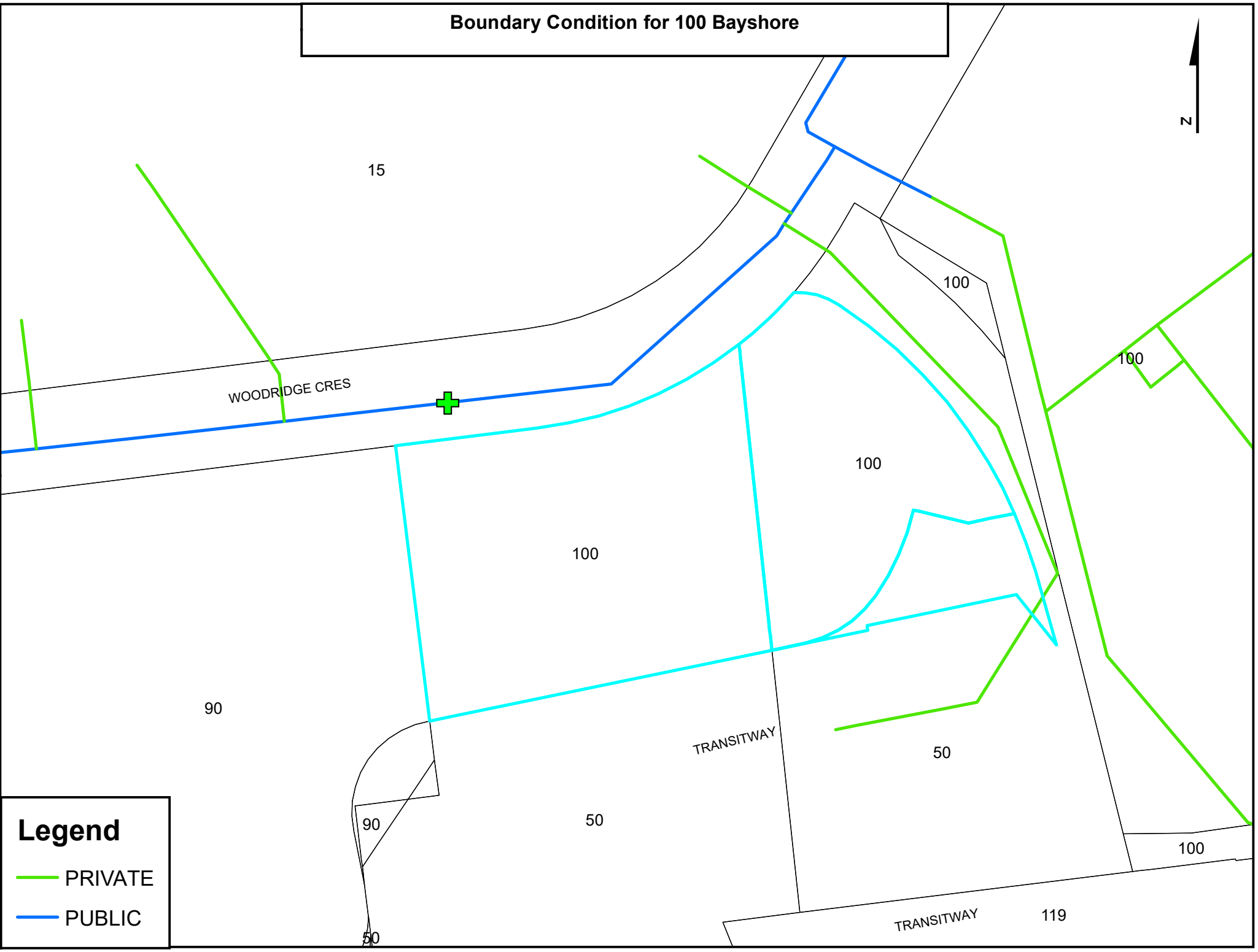

15

WOODRIDGE CRES



100

100

100

100

90

TRANSITWAY

50

## Legend

- PRIVATE
- PUBLIC

90

50

100

TRANSITWAY

119

50

Day 1,

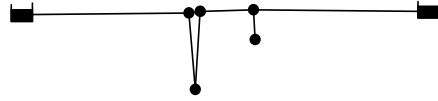

```
*****
*                               E P A N E T                               *
*                               Hydraulic and Water Quality                 *
*                               Analysis for Pipe Networks                   *
*                               Version 2.0                               *
*****
```

Input File: 100 Bayshore Dr - Model.net

Link - Node Table:

Link ID	Start Node	End Node	Length m	Diameter mm
10	SiteConnection1	SiteConnection2	3	203
11	SiteConnection1	Building	13	150
12	SiteConnection2	Building	13	150
13	SiteConnection2	SiteHydrantConnection		8 203
14	SiteHydrantConnection	EastSupply		50 203
15	WestSupply	SiteConnection1	50	203
16	SiteHydrantConnection	SiteHydrant		6 150

Node Results:

Node ID	Demand LPS	Head m	Pressure m	Quality
SiteConnection2	0.00	115.20	51.50	0.00
Building	2.86	115.20	51.20	0.00
SiteConnection1	0.00	115.20	51.50	0.00
SiteHydrantConnection		0.00 115.20	51.50	0.00
SiteHydrant	0.00	115.20	48.20	0.00
WestSupply	-1.49	115.20	0.00	0.00 Reservoir
EastSupply	-1.37	115.20	0.00	0.00 Reservoir

Link Results:

Link ID	Flow LPS	Velocity m/s	Headloss m/km	Status
10	0.06	0.00	0.00	Open
11	1.43	0.08	0.12	Open
12	1.43	0.08	0.12	Open
13	-1.37	0.04	0.02	Open
14	-1.37	0.04	0.02	Open
15	1.49	0.05	0.02	Open
16	0.00	0.00	0.00	Open

```

*****
*                               E P A N E T                               *
*                               Hydraulic and Water Quality                 *
*                               Analysis for Pipe Networks                   *
*                               Version 2.0                                 *
*****
    
```

Input File: 100 Bayshore Dr - Model.net

Link - Node Table:

Link ID	Start Node	End Node	Length m	Diameter mm
10	SiteConnection1	SiteConnection2	3	203
11	SiteConnection1	Building	13	150
12	SiteConnection2	Building	13	150
13	SiteConnection2	SiteHydrantConnection		8 203
14	SiteHydrantConnection	EastSupply		50 203
15	WestSupply	SiteConnection1	50	203
16	SiteHydrantConnection	SiteHydrant		6 150

Node Results:

Node ID	Demand LPS	Head m	Pressure m	Quality
SiteConnection2	0.00	106.27	42.57	0.00
Building	15.72	106.24	42.24	0.00
SiteConnection1	0.00	106.27	42.57	0.00
SiteHydrantConnection		0.00 106.28	42.58	0.00
SiteHydrant	0.00	106.28	39.28	0.00
WestSupply	-8.17	106.30	0.00	0.00 Reservoir
EastSupply	-7.55	106.30	0.00	0.00 Reservoir

Link Results:

Link ID	Flow LPS	Velocity m/s	Headloss m/km	Status
10	0.31	0.01	0.00	Open
11	7.86	0.44	2.75	Open
12	7.86	0.44	2.75	Open
13	-7.55	0.23	0.49	Open
14	-7.55	0.23	0.49	Open
15	8.17	0.25	0.57	Open
16	0.00	0.00	0.00	Open

```
*****
*                               E P A N E T                               *
*                               Hydraulic and Water Quality                 *
*                               Analysis for Pipe Networks                   *
*                               Version 2.0                                 *
*****
```

Input File: 100 Bayshore Dr - Model.net

Link - Node Table:

Link ID	Start Node	End Node	Length m	Diameter mm
10	SiteConnection1	SiteConnection2	3	203
11	SiteConnection1	Building	13	150
12	SiteConnection2	Building	13	150
13	SiteConnection2	SiteHydrantConnection		8 203
14	SiteHydrantConnection	EastSupply		50 203
15	WestSupply	SiteConnection1	50	203
16	SiteHydrantConnection	SiteHydrant		6 150

Node Results:

Node ID	Demand LPS	Head m	Pressure m	Quality
SiteConnection2	0.00	80.86	17.16	0.00
Building	140.48	78.79	14.79	0.00
SiteConnection1	0.00	80.86	17.16	0.00
SiteHydrantConnection		0.00	81.09	17.39 0.00
SiteHydrant	0.00	81.09	14.09	0.00
WestSupply	-73.05	82.50	0.00	0.00 Reservoir
EastSupply	-67.43	82.50	0.00	0.00 Reservoir

Link Results:

Link ID	Flow LPS	Velocity m/s	Headloss m/km	Status
10	2.81	0.09	0.08	Open
11	70.24	3.97	158.92	Open
12	70.24	3.97	158.91	Open
13	-67.43	2.08	28.29	Open
14	-67.43	2.08	28.29	Open
15	73.05	2.26	32.81	Open
16	0.00	0.00	0.00	Open



December 12<sup>th</sup>, 2019

WSP  
Stephen McCaughey  
[Stephen.McCaughey@wsp.com](mailto:Stephen.McCaughey@wsp.com)

Re: 100 Bayshore – Fire flow's and confirmation of building classification

Good morning Stephen,

As per your request, This letter is to confirm that both buildings proposed for 100 Bayshore – lob B will have a building classification of O.B.C. 3.2.2.42 Group C, Any Height, Any area, Sprinklered

**O.B.C. 3.2.2.42 Group C, Any Height, Any area, Sprinklered**

*(1) Except as permitted by Articles 3.2.2.43. to 3.2.2.48., a building classified as Group C other than a retirement home shall conform to Sentence (2).*

*(2) Except as permitted by Article 3.2.2.16., the building referred to in Sentence (1) shall be of noncombustible construction, and,*

*(a) except as permitted by Sentence 3.2.2.7.(1), the building shall be sprinklered,*

*(b) except as permitted by Sentence (3), **floor assemblies shall be fire separations with a fire-resistance rating not less than 2 h,***

*(c) mezzanines shall have a fire-resistance rating not less than 1 h, and*

*(d) **loadbearing walls, columns and arches shall have a fire-resistance rating not less than that required for the supported assembly.***

*(3) In a building that contains dwelling units that have more than 1 storey, subject to the requirements of Sentence 3.3.4.2.(3), the floor assemblies, including floors over basements, which are entirely contained within these dwelling units, shall have a fire-resistance rating not less than 1 h but need not be constructed as fire separations.*

**Partners**

Barry J. Hobin  
OAA, FRAIC, Hon. Fellow AIA

William A. Davis  
OAA, MRAIC, Associate AIA

Gordon Lorimer  
OAA, FRAIC, Associate AIA

Wendy Brawley  
OAA, MRAIC, Associate AIA

Douglas Brooks  
Senior Arch. Tech.

**Directors**

Marc Thivierge, OAA

Reinhard Vogel

**Associates**

Bryan Bonell, OAA

William Ritcey

Dan Henhoeffler

Melanie Lamontagne, OAA

Rheal Labelle

Patrick Bisson, OAA

**Hobin Architecture  
Incorporated**

63 Pamilla Street  
Ottawa, Ontario  
Canada K1S 3K7

☎ 613-238-7200

☎ 613-235-2005

[hobinarc.com](http://hobinarc.com)



The current assumption is that the the floors, structural frame and the roofs will be constructed of non-combustible construction and composed of poured concrete which will meet the fire resistance ratings requirements described in the O.B.C. section stated above.

Please let me know if you require any more information with respect to the fire rating requirements for this proposed development.

Regards,

A handwritten signature in black ink, appearing to read "Patrick Bisson". The signature is fluid and cursive, with a large initial "P" and a long, sweeping underline.

Patrick Bisson, OAA



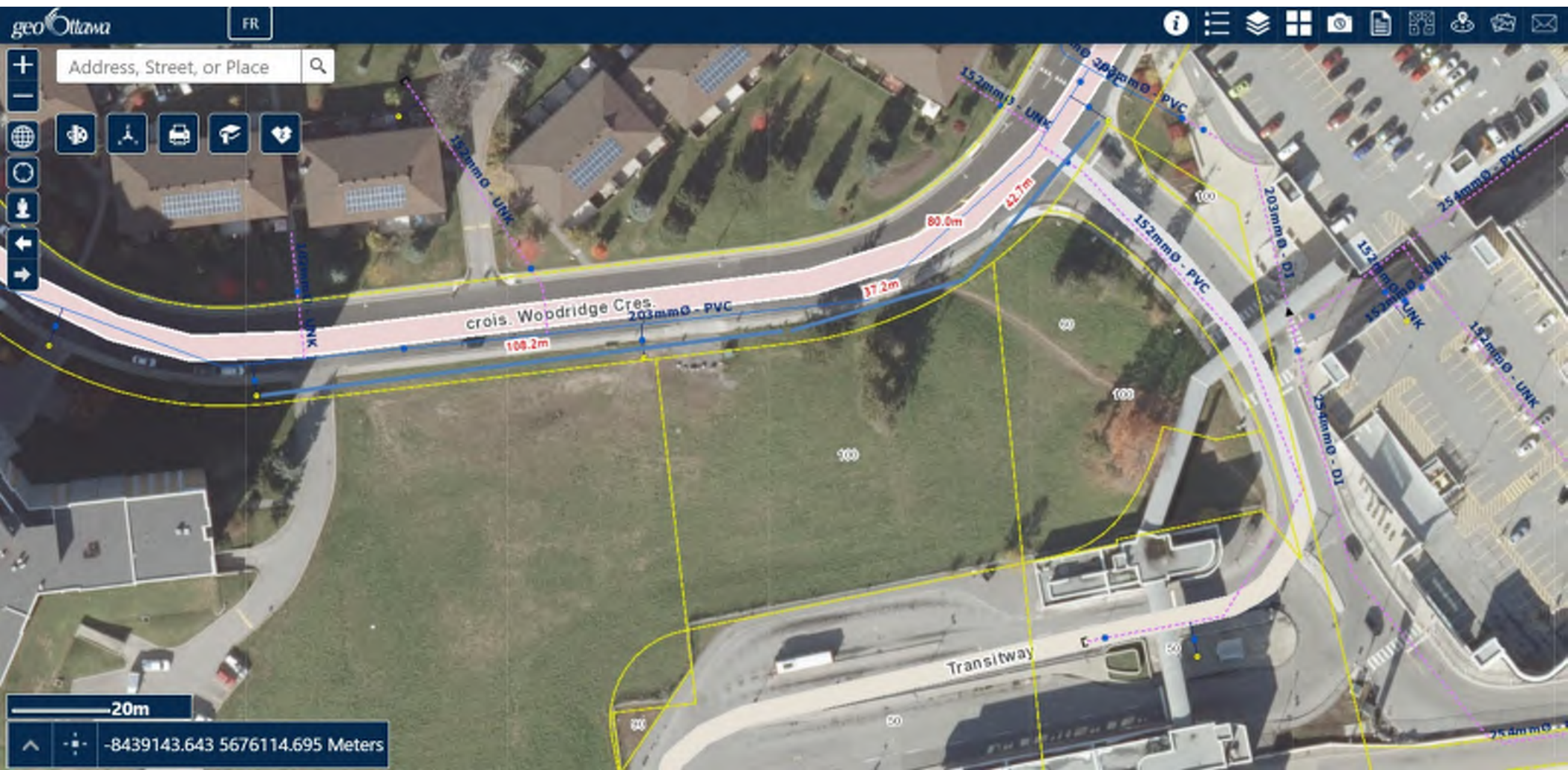

# B SANITARY DEMAND

### SANITARY SEWAGE - PROPOSED SANITARY FLOWS

<b>Average Wastewater Flows:</b>	
Residential	280 L/c/d
Commercial	28,000 L/gross ha/d
Institutional	28,000 L/gross ha/d
Light Industrial	35,000 L/gross ha/d
Heavy Industrial	55,000 L/gross ha/d

<b>Peaking Factors:</b>	
Residential	Harmon Equation
Commercial (>20% Area)	1.5
Commercial (<20% Area)	1.0
Institutional (>20% Area)	1.5
Institutional (<20% Area)	1.0
Industrial	Per Figure in Appendix 4-B

$$P.F. = 1 + \left( \frac{14}{4 + \left( \frac{P}{1000} \right)^{0.5}} \right) * K$$

where P = population  
K = correction factor = 0.8

<b>Peak Extraneous Flows:</b>	
Infiltration Allowance	0.33
<b>Less than 10 ha:</b>	
Foundation Drain Allowance	5.0
<b>10 ha - 100 ha:</b>	
Foundation Drain Allowance	3.0
<b>Greater than 100 ha:</b>	
Foundation Drain Allowance	2.0

Unit Type	Person Per Unit	East Tower	West Tower
Single Family	3.4		
Semi-detached	2.7		
Duplex	2.3		
Townhouse (row)	2.7		
<b>Apartments:</b>			
Bachelor	1.4		
1 Bedroom	1.4	212	190
2 Bedroom	2.1	80	72
3 Bedroom	3.1		
Average Apt.	1.8		
<b>Total Population:</b>		<b>465</b>	<b>417</b>
<b>Total Area (ha):</b>		<b>0.3</b>	<b>0.3</b>

Demand Type=	Phase 1 (East Tower)			Phase 2 (West Tower)		
	Residential			Residential		
Average Day Demand=	280		L/c/d	280		L/c/d
Population	465			417		
Site Area (ha)	0.300			0.300		
<b>Average Daily Flow=</b>	280 x 465 = 130,144		L/day	280 x 417 = 116,816		L/day
	1.51		L/s	1.35		L/s
Peaking Factor Type	Residential			Residential		
Peaking Factor	3.39		*Max=4	3.41		*Max=4
	3.39	x	average day	3.41	x	average day
	3.39	x	130,144	3.41	x	116,816
<b>Peak Daily Flow=</b>	441,482		L/day	398,427		L/day
	5.11		L/s	4.61		L/s
Infiltration Allowance	0.33			0.33		
	0.33	x	lot area	0.33	x	lot area
<b>Peak Extraneous Flow=</b>	0.33	x	0.3	0.33	x	0.3
	0.10		L/s	0.10		L/s
	peak daily flow	+	extraneous flow	peak daily flow	+	extraneous flow
	5.11	+	0.10	4.61	+	0.10
<b>Total Peak Design Flow=</b>	5.21		L/s	4.71		L/s

<b>Phase 1 (East Tower) - Peak Design Flow =</b>	5.21 L/s
<b>Phase 2 (West Tower) - Peak Design Flow =</b>	4.71 L/s
<b>Total Peak Design Flow =</b>	9.92 L/s

**WSP Canada**  
Sanitary Sewer Design Sheet

LOCATION			RESIDENTIAL AREA AND POPULATION						INSTITUTIONAL			C+I+I	INFILTRATION			TOTAL FLOW (l/s)	PIPE					
CONNECTIONS	FROM MH	TO MH	AREA (Ha)	POP.	CUMMULATIVE		PEAK FACT.	PEAK FLOW (l/s)	AREA (Ha)	ACCU. AREA (Ha)	PEAK FLOW (l/s)	TOTAL AREA (Ha)	ACCU. AREA (Ha)	INFILT. FLOW (l/s)	TOTAL FLOW (l/s)	LENGTH (m)	DIA. (mm)	SLOPE (%)	CAP. (FULL) (l/s)	PIPE CAPACITY USED (%)	VEL. (FULL) (m/s)	
					AREA (Ha)	POP.																
Building	Building	SANMH2	0.6	882	0.60	882	3.4	9.72	0.000	0.000	0.00	0.6	0.6	0.20	<b>9.92</b>	3.8	150.00	1.1%	<b>15.63</b>	<b>63.5%</b>	0.88	
	SANMH2	SANMH1	0.0	0	0.60	882	0.0	9.72	0.000	0.000	0.00	0.0	0.6	0.20	<b>9.92</b>	11.3	150.00	1.0%	<b>15.03</b>	<b>66.0%</b>	0.85	
DESIGN PARAMETERS											Designed:		PROJECT:									
Residential: 280 L/cap/d Peak Factor = 3.4 Extraneous Flow = 0.33 l/s/ha Minimum Velocity = 0.60 m/s Manning's n = 0.013											Stephen McCaughey, P.Eng.		100 Bayshore Lot "B"									
											Checked:		LOCATION:									
											Ishaque Jafferjee, P.Eng.		100 Bayshore Dr., Lot B, Woodridge Cres., Ottawa, ON									
											Dwg. Reference:			File Ref.:			Date:			Sheet		
																	April 2021		1 of 1			

**WSP Canada**  
Sanitary Sewer Design Sheet

LOCATION			RESIDENTIAL AREA AND POPULATION						INSTITUTIONAL	C+I+H	INFILTRATION			TOTAL FLOW	PIPE						MANHOLE		
CONNECTIONS	FROM MH	TO MH	AREA (Ha)	POP.	CUMMULATIVE		PEAK FACT.	PEAK FLOW (l/s)	AREA (Ha)	ACCU. AREA (Ha)	PEAK FLOW (l/s)	TOTAL AREA (Ha)	ACCU. AREA (Ha)	INFILT. FLOW (l/s)	TOTAL FLOW (l/s)	LENGTH (m)	DIA. (mm)	SLOPE (%)	CAP. (FULL) (l/s)	PIPE CAPACITY USED (%)	VEL. (FULL) (m/s)	UP INVERT (m)	DOWN INVERT (m)
					AREA (Ha)	POP.																	
Building	Building	SANMH2	0.6	882	0.60	882	3.4	9.72	0.000	0.000	0.00	0.6	0.6	0.20	<b>9.92</b>	7.7	150.00	1.0%	<b>15.52</b>	<b>63.9%</b>	0.88	62.85	62.77
	SANMH2	SANMH1	0.0	0	0.60	882	0.0	9.72	0.000	0.000	0.00	0.0	0.6	0.20	<b>9.92</b>	7.4	150.00	0.9%	<b>14.81</b>	<b>66.9%</b>	0.84	62.77	62.70
DESIGN PARAMETERS									Designed: Stephen McCaughey, P.Eng.			PROJECT: 100 Bayshore Lot "B"											
Residential: 280 L/cap/d Peak Factor = 3.4 Extraneous Flow = 0.33 l/s/ha Minimum Velocity = 0.60 m/s Manning's n = 0.013									Checked: Ishaque Jafferjee, P.Eng.			LOCATION: 100 Bayshore Dr., Lot B, Woodridge Cres., Ottawa, ON											
									Dwg. Reference:			File Ref.: 211-02810-00			Date: July 2021			Sheet 1 of 1					

# C SITE DRAWINGS



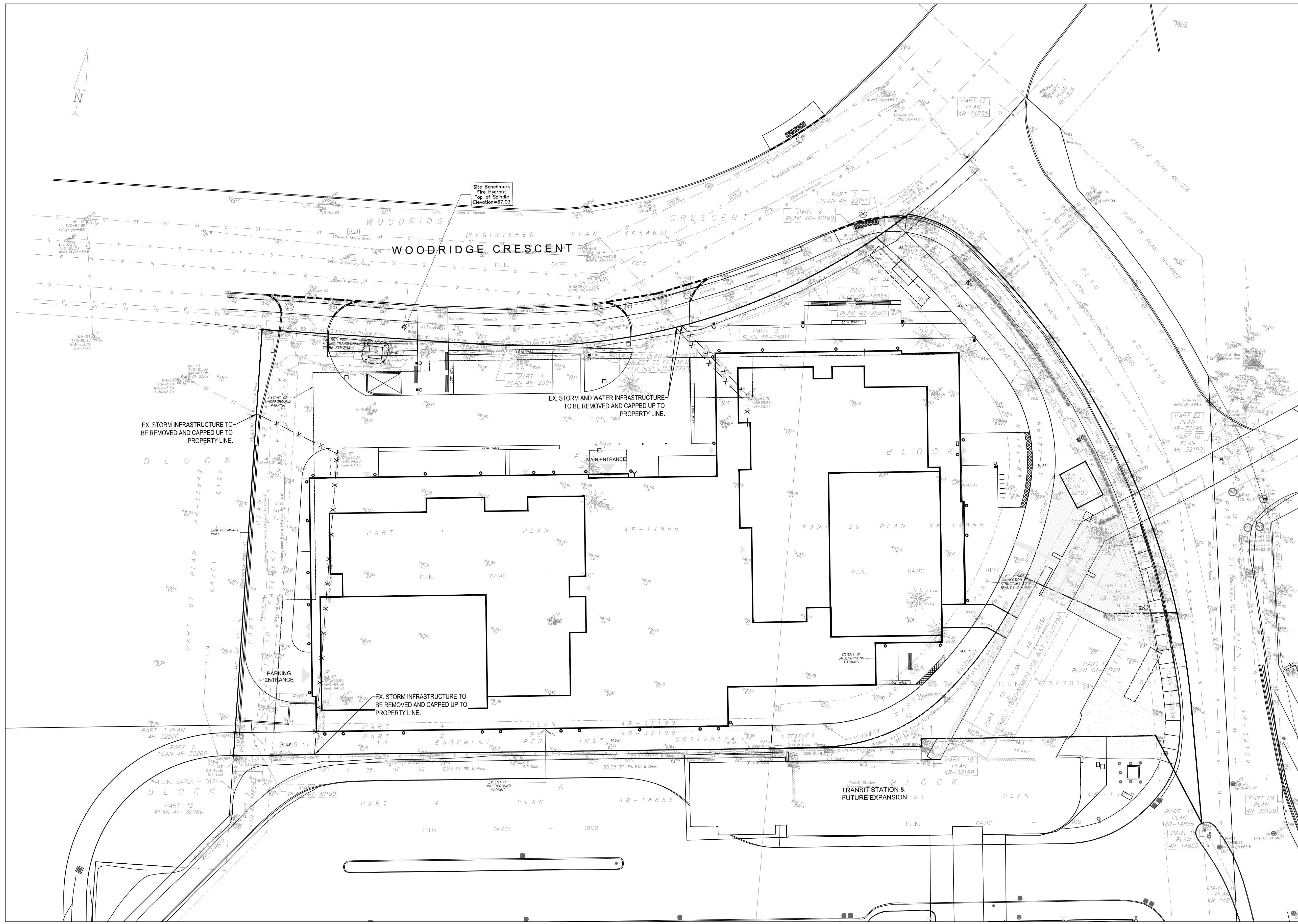

**LEGEND**

⊗ 66.50	PROPOSED GRADE ELEVATION
⊗ 66.50/66.35	PROPOSED TOP AND BOTTOM OF CURB
○	PROPOSED STORM SEWER MANHOLE
○	PROPOSED SANITARY SEWER MANHOLE
⊗	PROPOSED CATCHBASIN MANHOLE
□	PROPOSED CATCHBASIN
—	PROPOSED STORM SEWER
—	PROPOSED SANITARY SEWER
—	PROPOSED WATER SERVICE LINE
⊕	PROPOSED VALVE BOX
▽	PROPOSED REDUCER
⊕	PROPOSED FIRE HYDRANT
—	PROPOSED DEPRESSED CURB
—	SERVICES TO BE REMOVED
⊗ 65.96	EXISTING GRADE ELEVATION
⊗	EXISTING MANHOLE
⊗	EXISTING CATCHBASIN
⊕	EXISTING VALVE & BOX
▽	EXISTING FIRE HYDRANT
—	EXISTING STORM SEWER
—	EXISTING SANITARY SEWER
—	EXISTING WATERMAIN
—	EXISTING GASMAIN
—	EXISTING CABLE
—	EXISTING HYDRO
—	DRAINAGE AREA BOUNDARY
⊗	DRAINAGE AREA

1 UTILITY REMOVAL PLAN  
C001 SCALE= 1:250

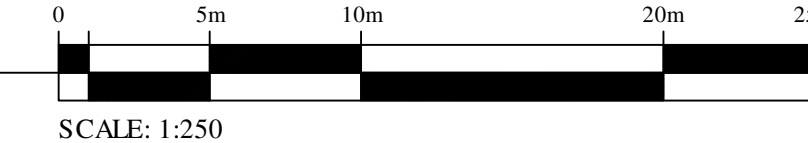

**PROJECT TEAM**

**ARCHITECT**  
HOBBS ARCHITECTURE  
PAUL KIRKSON  
B13.238.7200

**PLANNING**  
Q9 Planning + Design  
Christine McCauley  
B13.850.8343

**CIVIL**  
WSP  
STEPHEN McCAUGHEY  
B13.690.3955

**LANDSCAPE ARCHITECT**  
CSW LANDSCAPE ARCHITECTS LTD.  
B13.729.4538

**INSURANCE**  
REGROUP  
DAVID HOOK  
B13.225.1311 ext: 64029

**ENVIRONMENTAL**  
GRADIENT WIND ENGINEERING  
JOSHUA FOSTER  
B13.836.0634

no.	date	revision
3	2021-12-17	ISSUED FOR SPA REVISION 3
2	2021-09-17	ISSUED FOR SPA REVISION 2
1	2021-07-23	ISSUED FOR SPA REVISION 1

It is the responsibility of the appropriate contractor to check and verify all dimensions on site and report all errors and/or omissions to the architect.

All contractors must comply with all pertinent codes and by-laws.

Do not scale drawings.

This drawing may not be used for construction until signed.

Copyright reserved.

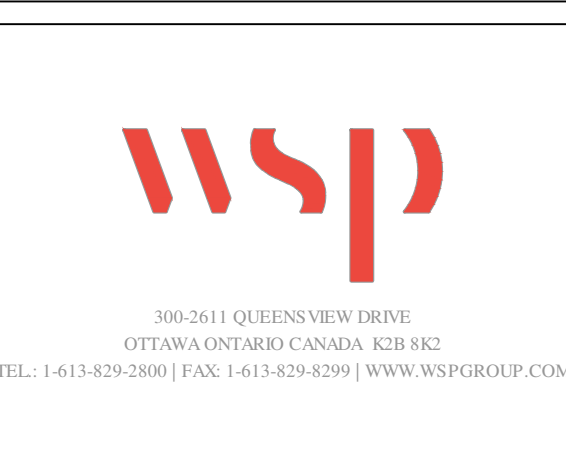

**PROJECT LOCATION:**  
100 BAYSHORE LOT "B"  
WOODRIDGE CRESCENT

**DRAWING TITLE:**  
CIVIL REMOVAL PLAN

**DRAWN BY:** EN / SM    **DATE:** DEC 17, 2021    **SCALE:** AS NOTED

**PROJECT:** 211-02810-00  
**DRAWING NO.:** C001  
**REVISION NO.:**

D07-12-21-0057



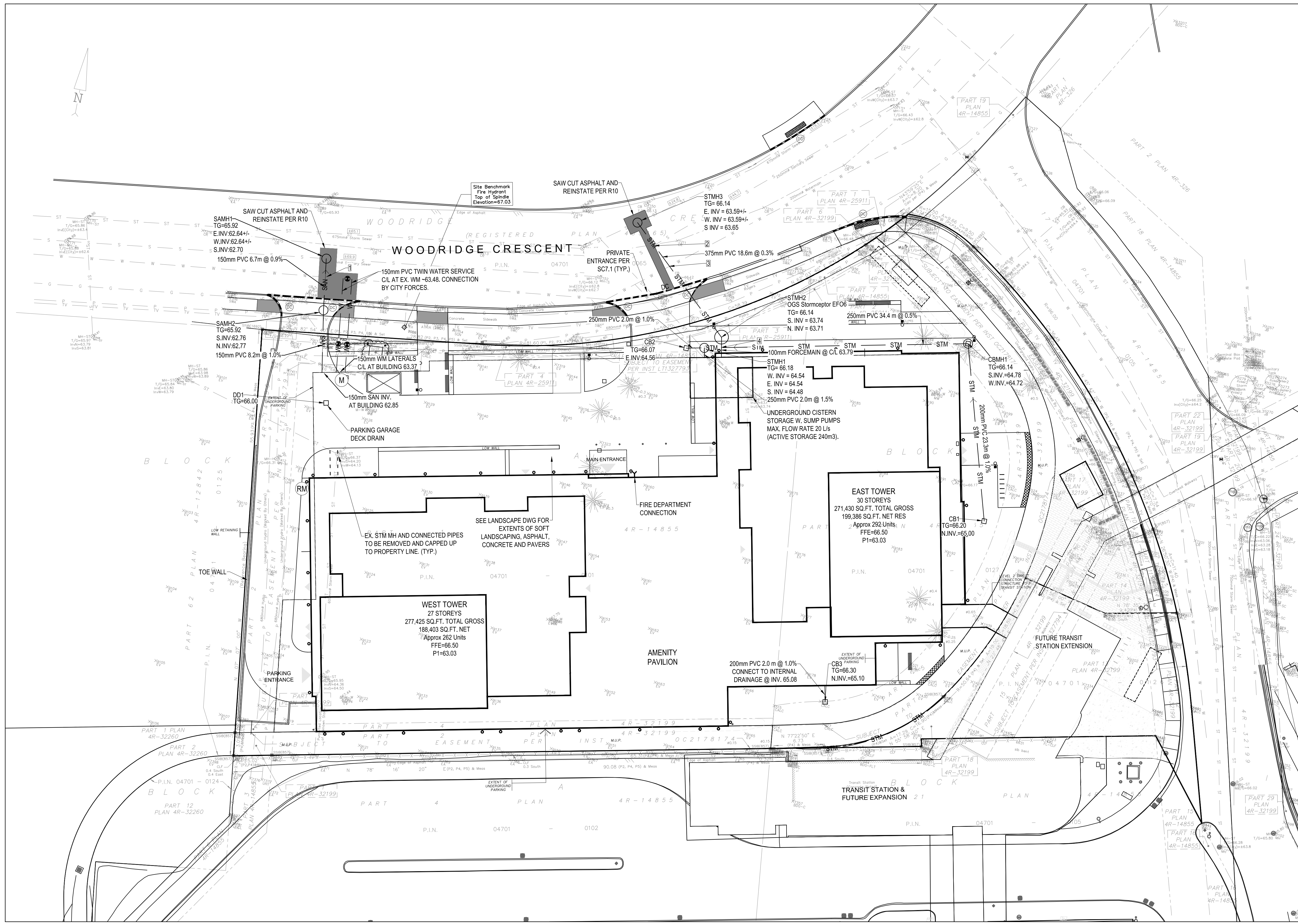

**LEGEND**

- 66.50 PROPOSED GRADE ELEVATION
- 66.50/66.35 PROPOSED TOP AND BOTTOM OF CURB
- STMH PROPOSED STORM SEWER MANHOLE
- SAMH PROPOSED SANITARY SEWER MANHOLE
- CBMH PROPOSED CATCHBASIN MANHOLE
- CB PROPOSED CATCHBASIN
- STM PROPOSED STORM SEWER
- SAN PROPOSED SANITARY SEWER
- W PROPOSED WATER SERVICE LINE
- PROPOSED VALVE BOX
- PROPOSED REDUCER
- FH PROPOSED FIRE HYDRANT
- DC PROPOSED DEPRESSED CURB
- X SERVICES TO BE REMOVED
- 65.96 EXISTING GRADE ELEVATION
- MH EXISTING MANHOLE
- CB EXISTING CATCHBASIN
- VB EXISTING VALVE & BOX
- FH EXISTING FIRE HYDRANT
- STM EXISTING STORM SEWER
- SAN EXISTING SANITARY SEWER
- W EXISTING WATERMAIN
- G EXISTING GASMAIN
- TV EXISTING CABLE
- P EXISTING HYDRO
- DRAINAGE AREA BOUNDARY
- DRAINAGE AREA

**1 SERVICING PLAN**  
C002 SCALE= 1:250

**NOTES: STORM SEWERS AND STRUCTURES**

- ALL STORM SEWER MATERIALS AND CONSTRUCTION METHODS SHALL CONFORM TO THE CURRENT CITY OF OTTAWA STANDARDS AND SPECIFICATIONS. PROVIDE CCTV INSPECTION REPORTS FOR ALL NEW STORM SEWERS, SERVICES AND CH LEADS.
- STORM SEWERS 450mm DIAMETER AND SMALLER SHALL BE PVC SDR-35, WITH RUBBER GASKET PER CSA A-257.3.
- STORM SEWER LARGER THAN 450mm SHALL BE REINFORCED CONCRETE CLASS 100.
- SEWER BEDDING AS PER CITY OF OTTAWA DETAIL S6.
- ALL STORM MANHOLES TO BE AS PER STORM STRUCTURE TABLE.
- ANY NEW OR EXISTING STORM SEWER WITH LESS THAN 2.0m COVER REQUIRES THERMAL INSULATION AS PER CITY OF OTTAWA STANDARD W22, OR APPROVED BY THE ENGINEER.
- ALL CATCHBASIN LEADS TO BE MINIMUM 200mm DIAMETER AT MINIMUM 1.0% SLOPE UNLESS OTHERWISE SPECIFIED.
- STORM CATCHBASINS AS PER OPSD 705.010 AND FRAME/COVER AS PER CITY STANDARD DRAWINGS S19. STORM CBMHs AS INDICATED IN TABLE WITH SLUMP. ADJUSTMENT SECTIONS SHALL BE AS PER OPSD 704.010. REAR YARD CATCHBASINS PER S30 AND S31.
- INSTALLATION OF FLOW CONTROL ICDS TO BE VERIFIED BY QUALITY VERIFICATION ENGINEER RETAINED BY CONTRACTOR.
- PROVIDE BACKWATER VALVE ON FOUNDATION DRAIN AT BUILDING PER S14.

**NOTES: SANITARY SEWER AND MANHOLES**

- ALL SANITARY SEWER, SANITARY SEWER APPURTENANCES AND CONSTRUCTION METHODS SHALL CONFORM TO THE CURRENT CITY OF OTTAWA STANDARDS AND SPECIFICATIONS. PROVIDE CCTV INSPECTION REPORTS FOR ALL NEW SANITARY PIPING.
- SANITARY SEWER PIPE SIZE 150mm DIAMETER AND GREATER TO BE PVC SDR-35 (UNLESS SPECIFIED OTHERWISE) WITH RUBBER GASKET TYPE JOINTS IN CONFORMANCE WITH CSA B-182.2.3.4.
- SEWER BEDDING AS PER CITY OF OTTAWA DETAIL S6.
- ALL SANITARY MANHOLES 1200mm IN DIAMETER TO BE AS PER OPSD 701.01, FRAME AND COVER TO BE AS PER CITY OF OTTAWA STANDARD S25 AND S24.
- MAINTENANCE HOLE BENCHING AND PIPE OPENING ALTERNATIVES AS PER THE OPSD 701.021
- ANY SANITARY SEWER WITH LESS THAN 2.0m COVER REQUIRES THERMAL INSULATION AS PER CITY OF OTTAWA STANDARD W22, OR APPROVED BY THE ENGINEER.
- PROVIDE BACKWATER VALVE AT BUILDING PER S14.1

**NOTES: WATERMAIN**

- ALL WATERMAIN AND WATERMAIN APPURTENANCES, MATERIALS, CONSTRUCTION AND TESTING METHODS SHALL CONFORM TO THE CURRENT CITY OF OTTAWA AND MINISTRY OF ENVIRONMENT STANDARDS AND SPECIFICATIONS.
- ALL WATERMAIN 300mm DIAMETER AND SMALLER TO BE POLY VINYL CHLORIDE (PVC) CLASS 150 DR 18 MEETING AWWA SPECIFICATION C900.
- ALL WATERMAIN TO BE INSTALLED AT MINIMUM COVER OF 2.4m BELOW FINISHED GRADE. WHERE WATERMANS CROSS OVER OTHER UTILITIES, A MINIMUM 0.30m CLEARANCE SHALL BE MAINTAINED. WHERE WATERMANS CROSS UNDER OTHER UTILITIES, A MINIMUM 0.50m CLEARANCE SHALL BE MAINTAINED. WHERE THE MINIMUM SEPARATION CANNOT BE ACHIEVED, THE WATERMAIN SHALL BE INSTALLED AS PER CITY OF OTTAWA STANDARDS W25 AND W25.2. WHERE 2.4m MINIMUM DEPTH CANNOT BE ACHIEVED, THERMAL INSULATION SHALL BE PROVIDED AS PER CITY OF OTTAWA STANDARD W22. WHERE A WATERMAIN IS IN CLOSE PROXIMITY TO AN OPEN STRUCTURE, THERMAL INSULATION SHALL BE PROVIDED AS PER CITY OF OTTAWA STANDARD W23.
- CONCRETE THRUST BLOCKS AND MECHANICAL RESTRAINTS ARE TO BE INSTALLED AT ALL TEES, BENDS, HYDRANTS, REDUCERS, ENDS OF MAINS AND CONNECTIONS 100mm AND LARGER, IN ACCORDANCE WITH CITY OF OTTAWA STANDARDS W25.3 & W25.4.
- CATHODIC PROTECTION REQUIRED FOR ALL IRON FITTINGS AS PER CITY OF OTTAWA STANDARD W40 & W42.
- ALL VALVES AND VALVE BOXES AND CHAMBERS, HYDRANTS, AND HYDRANT VALVES AND ASSEMBLIES SHALL BE INSTALLED AS PER CITY OF OTTAWA STANDARD
- FIRE HYDRANT LOCATION AND INSTALLATION AS PER CITY OF OTTAWA STANDARD W18 & W19. CONTRACTOR TO PROVIDE FLOW TEST AND PAINTING OF NEW HYDRANT IN ACCORDANCE WITH CITY STANDARDS.
- IF WATER MAIN MUST BE DEFLECTED TO MEET ALIGNMENT, ENSURE THAT THE AMOUNT OF DEFLECTION USED IS LESS THAN HALF THAT RECOMMENDED BY THE MANUFACTURER.

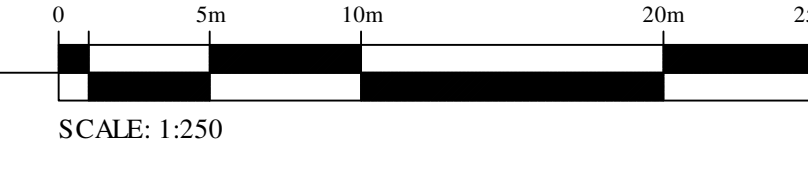

STRUCTURE ID	TOP OF GRATE ELEVATION	INVERT IN	INVERT OUT	SAN STRUCTURE TABLE		DESCRIPTION	NOTES
				INSULATION REQUIRED ON OUTLET PIPE?	SIZE		
SAMH1	65.92	62.70	62.64±		N	1200mm DIA, OPSD 701.010	S24
SAMH2	65.92	62.77	62.76		N	1200mm DIA, OPSD 701.010	S24

STRUCTURE ID	TOP OF GRATE ELEVATION	INVERT IN	INVERT OUT	STORM STRUCTURE TABLE		DESCRIPTION	NOTES
				INSULATION REQUIRED ON OUTLET PIPE?	SIZE		
DD1	66.00				N		Parking garage deck drain
CBMH1	66.14	64.78	64.72		Y	1200mm DIA, OPSD 701.010	S28.1
CB1	66.20		65.00		Y	600X600mm, OPSD 705.010	S19.1
CB2	66.07		64.56		Y	600X600mm, OPSD 705.010	S19.1
CB3	66.30		65.10		Y	600X600mm, OPSD 705.010	S19.1
STMH1	66.18	64.54	64.54		Y	1200mm DIA, OPSD 701.010	S24.1
STMH2	66.14	63.74	63.71		N	1800mm DIA, OPSD 701.012	Stormceptor Model EFO6
STMH3	66.14	63.59±	63.59±		N	1200mm DIA, S12.2	S24.1

PIPE CROSSING TABLE					
		Obvert	Invert		
1	150mm SAN	62.88	0.50	Clearance Under	63.38 200mm Ex. WM
2	200mm Ex. WM	63.38	0.29	Clearance Under	63.67 375mm STM
3	250mm Ex. SAN	63.05	0.61	Clearance Under	63.66 250mm STM
4	100mm STM FM	63.84	0.72	Clearance Under	64.56 250mm STM



**PROJECT TEAM**

**ARCHITECT**  
HOBAN ARCHITECTURE  
PAUL KIRKSON  
763.238.7200

**PLANNING**  
Q9 Planning + Design  
Christine McCreath  
763.850.8345

**CIVIL**  
WSP  
STEPHEN McCAUGHEY  
763.690.3955

**LANDSCAPE ARCHITECT**  
CSW LANDSCAPE ARCHITECTS LTD.  
763.729.4536

**INSPECTION**  
REGGOLD  
DAVID HOOK  
763.255.1311 ext: 64029

**ENVIRONMENTAL**  
GRADIENT WIND ENGINEERING  
JOSHUA FOSTER  
763.836.0634

no.	date	revision
4	2021-12-17	ISSUED FOR SPAREVISION 3
3	2021-09-17	ISSUED FOR SPAREVISION 2
2	2021-07-23	ISSUED FOR SPAREVISION 1
1	2021-04-28	ISSUED FOR SPA

It is the responsibility of the appropriate contractor to check and verify all dimensions on site and report all errors and/or omissions to the architect.

All contractors must comply with all pertinent codes and by-laws.

Do not scale drawings.

This drawing may not be used for construction until signed.

Copyright reserved.



**PROJECT LOCATION**

100 BAYSHORE LOT "B"  
WOODRIDGE CRESCENT

**SERVICING PLAN**

DRAWN BY: EN / ISM	DATE: DEC 17, 2021	SCALE: AS NOTED
PROJECT: 211-02810-00	DRAWING NO.:	C002
REVISION NO.:		



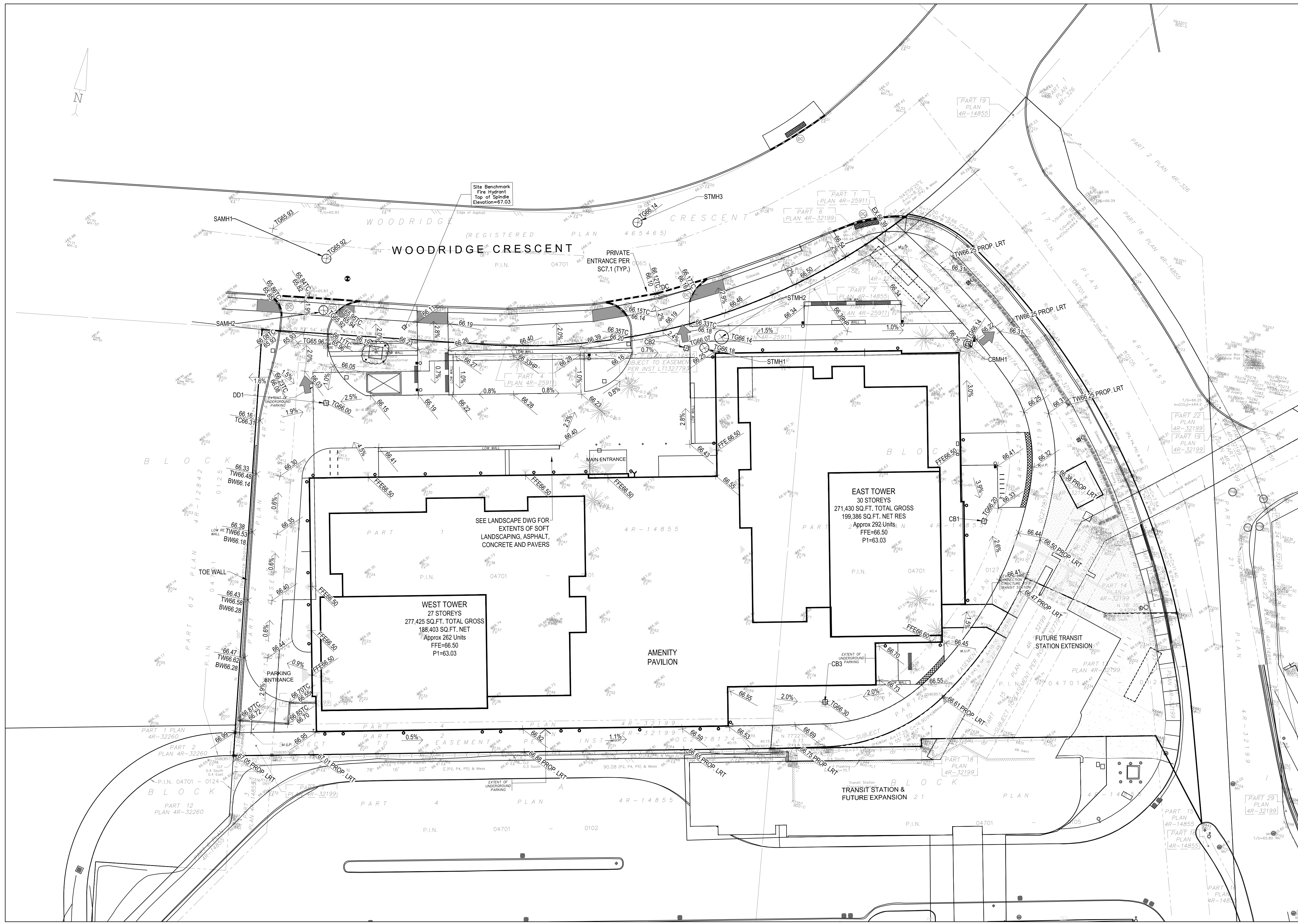

**LEGEND**

- ⊗ 66.50 PROPOSED GRADE ELEVATION
- ⊗ 66.50/10 PROPOSED TOP AND BOTTOM OF CURB
- STMH PROPOSED STORM SEWER MANHOLE
- SAMH PROPOSED SANITARY SEWER MANHOLE
- ⊗ CBMH PROPOSED CATCHBASIN MANHOLE
- CB PROPOSED CATCHBASIN
- STM — PROPOSED STORM SEWER
- SAN — PROPOSED SANITARY SEWER
- W — PROPOSED WATER SERVICE LINE
- ⊕ PROPOSED VALVE BOX
- ▽ PROPOSED REDUCER
- ⊕ FH PROPOSED FIRE HYDRANT
- DC — PROPOSED DEPRESSED CURB
- X — SERVICES TO BE REMOVED
- ⊗ 65.96 EXISTING GRADE ELEVATION
- ⊗ MH EXISTING MANHOLE
- ⊗ CB EXISTING CATCHBASIN
- ⊕ VB EXISTING VALVE & BOX
- ⊕ FH EXISTING FIRE HYDRANT
- STM — EXISTING STORM SEWER
- SAN — EXISTING SANITARY SEWER
- W — EXISTING WATERMAIN
- G — EXISTING GASMAIN
- TV — EXISTING CABLE
- P — EXISTING HYDRO
- ▬ DRAINAGE AREA BOUNDARY
- ⊗ 1 CONTROLLED DRAINAGE AREA

- NOTES:** GENERAL
- ALL SERVICES, MATERIALS, CONSTRUCTION METHODS AND INSTALLATIONS SHALL BE IN ACCORDANCE WITH THE LATEST STANDARDS AND REGULATIONS OF THE CITY OF OTTAWA, STANDARD SPECIFICATIONS AND DRAWINGS, ONTARIO PROVINCIAL SPECIFICATION STANDARD SPECIFICATION (OPSS) AND ONTARIO PROVINCIAL STANDARD DRAWINGS (OPSD).
  - THE POSITION OF EXISTING POLE LINES, CONDUITS, WATERMANS, SEWERS AND OTHER UNDERGROUND AND ABOVEGROUND UTILITIES, STRUCTURES AND APPURTENANCES IS NOT NECESSARILY SHOWN IN CONTRACT DRAWINGS, AND WHERE SHOWN, THE ACCURACY OF THE POSITION OF SUCH UTILITIES AND STRUCTURES IS NOT GUARANTEED. PRIOR TO CONSTRUCTION, THE CONTRACTOR SHALL VERIFY THE EXACT LOCATION OF ALL SUCH UTILITIES AND STRUCTURES, AND SHALL ASSUME ALL LIABILITY FOR DAMAGE TO THEM DURING THE COURSE OF CONSTRUCTION. ANY RELOCATION OF EXISTING UTILITIES REQUIRED BY THE DEVELOPMENT OF SUBJECT LOTS IS TO BE UNDERTAKEN AT CONTRACTOR'S EXPENSE.
  - THE CONTRACTOR MUST NOTIFY ALL EXISTING UTILITY COMPANIES FIVE (5) BUSINESS DAYS PRIOR TO START OF CONSTRUCTION AND HAVE ALL EXISTING UTILITIES AND SERVICES LOCATED IN THE FIELD PRIOR TO THE START OF CONSTRUCTION, INCLUDING BUT NOT LIMITED TO FIBRO, BELL, CABLE TV, AND CONSUMERS GAS LINES.
  - ALL TRENCHING AND EXCAVATIONS TO BE IN ACCORDANCE WITH THE LATEST REVISIONS OF THE OCCUPATIONAL HEALTH AND SAFETY ACT AND REGULATIONS FOR CONSTRUCTION PROJECTS.
  - REFER TO ARCHITECT'S PLANS FOR BUILDING DIMENSIONS, ELEVATIONS, LAYOUT AND DECK STRUCTURE. REFER TO LANDSCAPE PLAN FOR LANDSCAPED DETAILS AND OTHER RELEVANT INFORMATION. ALL INFORMATION SHALL BE CONFIRMED PRIOR TO COMMENCEMENT OF CONSTRUCTION.
  - TOPOGRAPHIC SURVEY COMPLETED AND PROVIDED BY FARLEY, SMITH & DENIS SURVEYING LTD. DATED MAY 13, 2021. CONTRACTOR TO VERIFY IN THE FIELD PRIOR TO CONSTRUCTION OF ANY WORK AND NOTIFY THE ENGINEER OF ANY DISCREPANCIES.
  - ALL ELEVATIONS ARE GEODETIC AND UTILIZE METRIC UNITS.
  - ALL GROUND SURFACES SHALL BE EVENLY GRADED WITHOUT PONING AREAS AND WITHOUT LOW POINTS EXCEPT WHERE APPROVED SWALE OR DRAIN OUTLETS ARE PROVIDED.
  - ALL EDGES OF DISTURBED PAVEMENT SHALL BE SAW CUT TO FORM A NEAT AND STRAIGHT LINE PRIOR TO PLACING NEW PAVEMENT. PAVEMENT REINSTATEMENT SHALL BE WITH STEP JOINTS OF 300MM WIDTH MINIMUM.
  - ALL DISTURBED AREAS OUTSIDE PROPOSED GRADING LIMITS TO BE RESTORED TO ORIGINAL ELEVATIONS AND CONDITIONS UNLESS OTHERWISE SPECIFIED. EXISTING PARKING LOT SHALL BE RE-ASPHALTED AT EXISTING GRADES EXCEPT AS NOTED TO EVEN OUT GROUES. ALL RESTORATION SHALL BE COMPLETED WITH THE GEOTECHNICAL REQUIREMENTS FOR BACKFILL AND COMPACTATION.
  - ALL MATERIAL SUPPLIED AND PLACED FOR PARKING LOT AND ACCESS ROAD CONSTRUCTION SHALL BE TO OPSS STANDARDS AND SPECIFICATIONS UNLESS OTHERWISE NOTED. CONSTRUCTION TO OPSS 206, 310 & 314. MATERIALS TO OPSS 100, 100 & 100.
  - ADJUTING PROPERTY GRADES TO BE MATCHED UNLESS NOTED OTHERWISE.
  - CONTRACTOR SHALL OBTAIN AND PAY FOR ALL NECESSARY PERMITS AND APPROVALS FROM THE MUNICIPAL AUTHORITIES PRIOR TO COMMENCING CONSTRUCTION.
  - MINIMIZE DISTURBANCE TO EXISTING VEGETATION DURING THE EXECUTION OF ALL WORKS.
  - REMOVE FROM SITE ALL EXCESS EXCAVATED MATERIAL UNLESS OTHERWISE DIRECTED FROM THE ENGINEER. ENCAVAITE AND REMOVE ALL ORGANIC MATERIAL AND OTHER DEBRIS LOCATED WITHIN THE PROPOSED BUILDING, PARKING AND ROADWAY LOCATIONS.
  - AT PROPOSED UTILITY CONNECTION POINTS AND CROSSINGS (I.E. STORM SEWER, SANITARY SEWER, WATER, ETC.) THE CONTRACTOR SHALL DETERMINE THE PRECISE LOCATION AND DEPTH OF EXISTING UTILITIES AND REPORT ANY DISCREPANCIES OR CONFLICTS TO THE ENGINEER BEFORE COMMENCING WORK.
  - SERVICE TRENCHES ON MUNICIPAL RIGHT OF WAY TO BE REINSTATE AS PER CITY OF OTTAWA DETAIL R10.
  - PRIOR TO CONSTRUCTION, A GEOTECHNICAL ENGINEER REGISTERED IN THE PROVINCE OF ONTARIO IS TO INSPECT ALL SUB-SURFACES FOR FOOTINGS, SERVICES AND PAVEMENT STRUCTURES.
  - FOR ANY SOILS RELATED INFORMATION, REFER TO THE GEOTECHNICAL INVESTIGATION REPORT BY GOLDER DATED MARCH 2021.
  - CONTRACTOR TO OBTAIN POST-CONSTRUCTION TOPOGRAPHIC SURVEY PERFORMED BY CERTIFIED OLS OR P/ENG. CONFIRMING COMPLIANCE WITH DESIGN GRADING AND SERVING SURVEY IS TO INCLUDE LOCATION AND INVERTS FOR BURIED UTILITIES.

- NOTES:** PARKING LOT AND WORK IN PUBLIC RIGHTS OF WAY
- CONTRACTOR TO OBTAIN ROAD CUT PERMIT PRIOR TO ROAD WORK AND REINSTATE ROAD CUTS AS PER CITY OF OTTAWA DETAIL R10.
  - REFER TO GEOTECHNICAL INVESTIGATION REPORT PREPARED BY GOLDER ASSOCIATES DATED MARCH 2021 FOR GEOTECHNICAL RECOMMENDATIONS.
  - CONTRACTOR TO PREPARE SUBGRADE, INCLUDING PROFILES, TO THE SATISFACTION OF THE GEOTECHNICAL CONSULTANT PRIOR TO THE COMMENCEMENT OF PLACEMENT OF GRANULAR B MATERIAL.
  - FILL TO BE PLACED AND COMPACTED PER THE GEOTECHNICAL REPORT REQUIREMENTS.
  - CONTRACTOR TO SUPPLY, PLACE AND COMPACT GRANULAR A MATERIAL IN ACCORDANCE WITH THE RECOMMENDATIONS OF THE GEOTECHNICAL CONSULTANT. CONTRACTOR TO PROVIDE CONSULTANT WITH SAMPLES OF GRANULAR A MATERIAL FOR TESTING AND CERTIFICATION FROM THE GEOTECHNICAL CONSULTANT THAT THE MATERIAL MEETS THE GRADATION REQUIREMENTS SPECIFIED IN THE GEOTECHNICAL REPORT.
  - GRANULAR A MATERIAL TO BE PLACED ONLY UPON APPROVAL BY THE GEOTECHNICAL CONSULTANT OF GRANULAR B PLACEMENT.
  - CONTRACTOR TO SUPPLY, PLACE AND COMPACT GRANULAR B MATERIAL IN ACCORDANCE WITH THE RECOMMENDATIONS OF THE GEOTECHNICAL CONSULTANT. CONTRACTOR TO PROVIDE CONSULTANT WITH SAMPLES OF GRANULAR B MATERIAL FOR TESTING AND CERTIFICATION FROM THE GEOTECHNICAL CONSULTANT THAT THE MATERIAL MEETS THE GRADATION REQUIREMENTS SPECIFIED IN THE GEOTECHNICAL REPORT.
  - ASPHALT MATERIAL TO BE PLACED ONLY UPON APPROVAL BY THE GEOTECHNICAL CONSULTANT OF GRANULAR A PLACEMENT.
  - CONTRACTOR TO SUPPLY, PLACE AND COMPACT ASPHALT MATERIAL IN ACCORDANCE WITH THE RECOMMENDATIONS OF THE GEOTECHNICAL CONSULTANT. CONTRACTOR TO PROVIDE CONSULTANT WITH SAMPLES OF ASPHALT MATERIAL FOR TESTING AND CERTIFICATION FROM THE GEOTECHNICAL CONSULTANT THAT THE MATERIAL MEETS THE REQUIREMENTS SPECIFIED IN THE GEOTECHNICAL REPORT.
  - CONTRACTOR IS RESPONSIBLE FOR ESTABLISHING LINE AND GRADE IN ACCORDANCE WITH THE PLANS, AND FOR PROVIDING THE CONSULTANT WITH VERIFICATION PRIOR TO PLACEMENT.
  - ALL EXCESS MATERIAL TO BE HAILED OFFSITE AND DISPOSED OF AT AN APPROVED DUMP SITE. SHOULD THE CONTRACTOR DISCOVER ANY HAZARDOUS MATERIAL, CONTRACTOR IS TO NOTIFY CONSULTANT. CONSULTANT TO DETERMINE APPROPRIATE DISPOSAL METHODOLOGY.
  - PAVEMENT STRUCTURE (MATERIAL TYPES AND THICKNESS) TO BE AS SPECIFIED IN THE GEOTECHNICAL REPORT.

1 GRADING PLAN  
C003 SCALE= 1:250

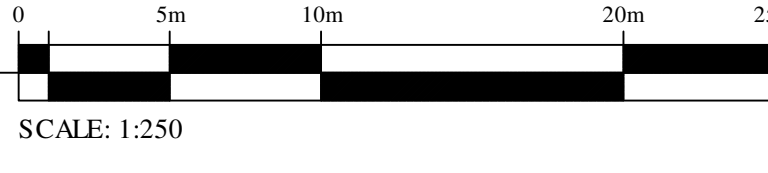

PAVEMENT COMPONENT	
SUPERPAVE 12.5 SURFACE COURSE	50mm
SUPERPAVE 19.0mm BASE COURSE	70mm
OPPS GRANULAR A BASE	150mm
OPPS GRANULAR B TYPE II SUBBASE	450mm



**PROJECT TEAM**

**ARCHITECT**  
HOBBS ARCHITECTURE  
PAUL KIRKSON  
B13.238.7200

**PLANNING**  
Q9 Planning + Design  
Christine McCaskey  
B13.850.8345

**CIVIL**  
WSP  
STEPHEN McCALGHEY  
B13.690.3955

**LANDSCAPE ARCHITECT**  
CSW LANDSCAPE ARCHITECTS LTD.  
B13.729.4536

**TRANSPORTATION**  
REGROUP  
DAVID HEDDER  
B13.225.1311 ext: 64029

**ENVIRONMENTAL**  
GRADIENT WIND ENGINEERING  
JOSHUA FOSTER  
B13.836.0634

no.	date	revision
4	2021-12-17	ISSUED FOR SPAREVISION 3
3	2021-09-17	ISSUED FOR SPAREVISION 2
2	2021-07-23	ISSUED FOR SPAREVISION 1
1	2021-04-28	ISSUED FOR SPA

It is the responsibility of the appropriate contractor to check and verify all dimensions on site and report all errors and/or omissions to the architect.

All contractors must comply with all pertinent codes and by-laws.

Do not scale drawings.

This drawing may not be used for construction until signed.

Copyright reserved.



**PROJECT LOCATION:**  
100 BAYSHORE LOT "B"  
WOODRIDGE CRESCENT

**DRAWING TITLE:**  
GRADING PLAN

**DRAWN BY:** EN / S.M. **DATE:** DEC 17, 2021 **SCALE:** AS NOTED

**PROJECT:** 211-02810-00

**DRAWING NO.:** C003

**REVISION NO.:**



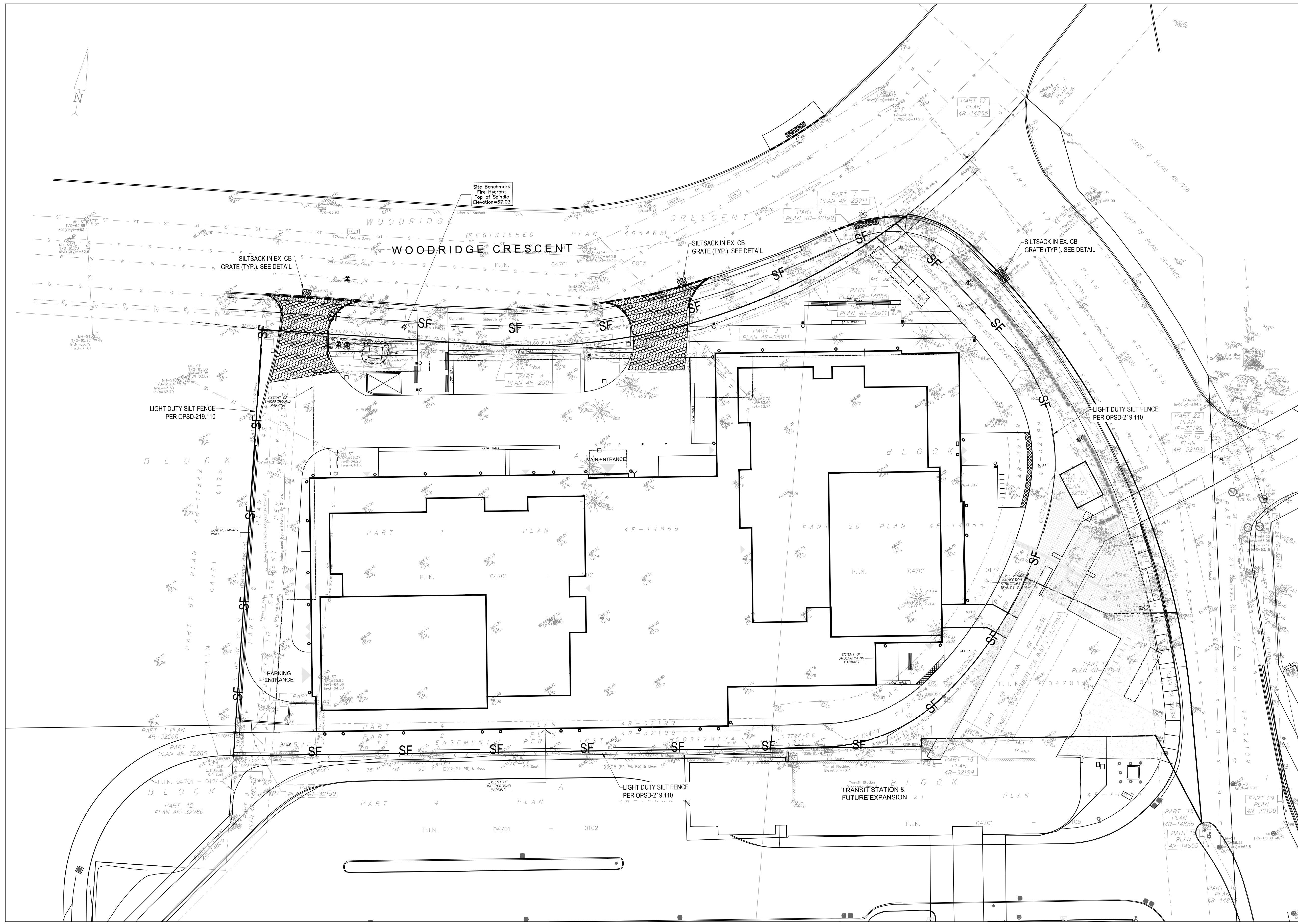

**LEGEND**

66.50	PROPOSED GRADE ELEVATION
66.50TC	PROPOSED TOP AND BOTTOM OF CURB
STMH	PROPOSED STORM SEWER MANHOLE
SAMH	PROPOSED SANITARY SEWER MANHOLE
CBMH	PROPOSED CATCHBASIN MANHOLE
CB	PROPOSED CATCHBASIN
STM	PROPOSED STORM SEWER
SAN	PROPOSED SANITARY SEWER
W	PROPOSED WATER SERVICE LINE
VB	PROPOSED VALVE BOX
REDUCER	PROPOSED REDUCER
FH	PROPOSED FIRE HYDRANT
DC	PROPOSED DEPRESSED CURB SERVICES TO BE REMOVED
65.96	EXISTING GRADE ELEVATION
MH	EXISTING MANHOLE
CB	EXISTING CATCHBASIN
VB	EXISTING VALVE & BOX
FH	EXISTING FIRE HYDRANT
STM	EXISTING STORM SEWER
SAN	EXISTING SANITARY SEWER
W	EXISTING WATERMAIN
G	EXISTING GASMAIN
TV	EXISTING CABLE
P	EXISTING HYDRO
DRAINAGE AREA BOUNDARY	DRAINAGE AREA

- NOTES:** EROSION AND SEDIMENT CONTROL
- \*\* CONTRACTOR IS RESPONSIBLE FOR ALL INSTALLATION, MONITORING, REPAIR AND REMOVAL OF ALL EROSION AND SEDIMENT CONTROL FEATURES. \*\*
- PRIOR TO START OF CONSTRUCTION:
    - INSTALL SILT FENCE IN LOCATION SHOWN ON DWG C12.
    - INSTALL FILTER FABRIC OR SILT SACK FILTERS IN ALL THE CATCHBASINS AND MANHOLES TO REMAIN DURING CONSTRUCTION WITHIN THE SITE (SEE TYPICAL DETAILS).
    - INSTALL MUD MAT AT SITE ENTRANCES.
  - DURING CONSTRUCTION:
    - MINIMIZE THE EXTENT OF DISTURBED AREAS AND THE DURATION OF EXPOSURE AND IMPACTS TO EXISTING GRADING.
    - PERIMETER VEGETATION TO REMAIN IN PLACE UNTIL PERMANENT STORM WATER MANAGEMENT IS IN PLACE. OTHERWISE, IMMEDIATELY INSTALL SILT FENCE. WHEN THE EXISTING SITE IS DISTURBED AT THE PERIMETER.
    - PROTECT DISTURBED AREAS FROM OVERLAND FLOW BY PROVIDING TEMPORARY SWALES TO THE SATISFACTION OF THE FIELD ENGINEER. TIE-IN TEMPORARY SWALE TO EXISTING CDS AS REQUIRED.
    - DURING DEMOLITION OF EXISTING ON-SITE STORM INFRASTRUCTURE, PROTECT DOWNSTREAM SEWERS FROM UNFILTERED FLOW.
    - INSPECT SILT FENCES, FILTER FABRIC FILTERS AND CATCH BASIN SUMP'S WEEKLY AND WITHIN 24 HOURS AFTER A STORM EVENT. CLEAN AND REPAIR WHEN NECESSARY.
    - DRAWING TO BE REVIEWED AND REVISED AS REQUIRED DURING CONSTRUCTION.
    - EROSION CONTROL FENCING TO BE ALSO INSTALLED AROUND THE BASE OF ALL STOCKPILES.
    - DO NOT LOCATE TOPSOIL PILES AND EXCAVATION MATERIAL CLOSER THAN 2.5m FROM ANY PAVED SURFACE, OR ONE WHICH IS TO BE PAVED BEFORE THE PILE IS REMOVED. ALL TOPSOIL PILES ARE TO BE SEEDED IF THEY ARE TO REMAIN ON SITE LONG ENOUGH FOR SEEDS TO GROW (LONGER THAN 30 DAYS).
    - CONTROL WIND-BLOWN DUST OFF SITE BY SEEDING TOPSOIL PILES AND OTHER AREAS TEMPORARILY (PROVIDE WATERING AS REQUIRED AND TO THE SATISFACTION OF THE ENGINEER).
    - NO ALTERNATE METHODS OF EROSION PROTECTION SHALL BE PERMITTED UNLESS APPROVED BY THE FIELD ENGINEER.
    - CITY ROADWAY AND SIDEWALK TO BE CLEANED OF ALL SEDIMENT FROM VEHICULAR TRACKING AS REQUIRED.
    - DURING WET CONDITIONS, TIRES OF ALL VEHICLES/EQUIPMENT LEAVING THE SITE ARE TO BE SCRAPPED.
    - ANY MUD/MATERIAL TRACKED ONTO THE ROAD SHALL BE REMOVED IMMEDIATELY BY HAND OR RUBBER TIRE LOADER.
    - TAKE ALL NECESSARY STEPS TO PREVENT BUILDING MATERIAL, CONSTRUCTION DEBRIS OR WASTE BEING SPILLED OR TRACKED ONTO ADJACENT PROPERTIES OR PUBLIC STREETS DURING CONSTRUCTION AND PROCEED IMMEDIATELY TO CLEAN UP ANY AREAS SO AFFECTED.
    - ALL EROSION CONTROL STRUCTURE TO REMAIN IN PLACE UNTIL ALL DISTURBED GROUND SURFACES HAVE BEEN STABILIZED EITHER BY PAVING OR RESTORATION OF VEGETATIVE GROUND COVER.
    - THE CONTRACTOR SHALL IMPLEMENT BEST MANAGEMENT PRACTICES, TO PROVIDE FOR PROTECTION OF THE AREA DRAINAGE SYSTEM AND THE RECEIVING WATERCOURSE, DURING CONSTRUCTION ACTIVITIES. THE CONTRACTOR ACKNOWLEDGES THAT FAILURE TO IMPLEMENT APPROPRIATE EROSION AND SEDIMENT CONTROL MEASURES MAY BE SUBJECT TO PENALTIES IMPOSED BY ANY APPLICABLE REGULATORY AGENCY.

**1 EROSION AND SEDIMENT CONTROL PLAN**  
 C004 SCALE= 1:250

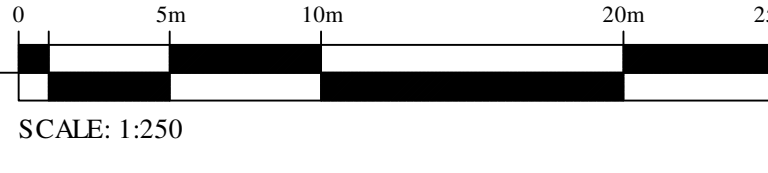

**Typical Siltsack® Construction - Type B**

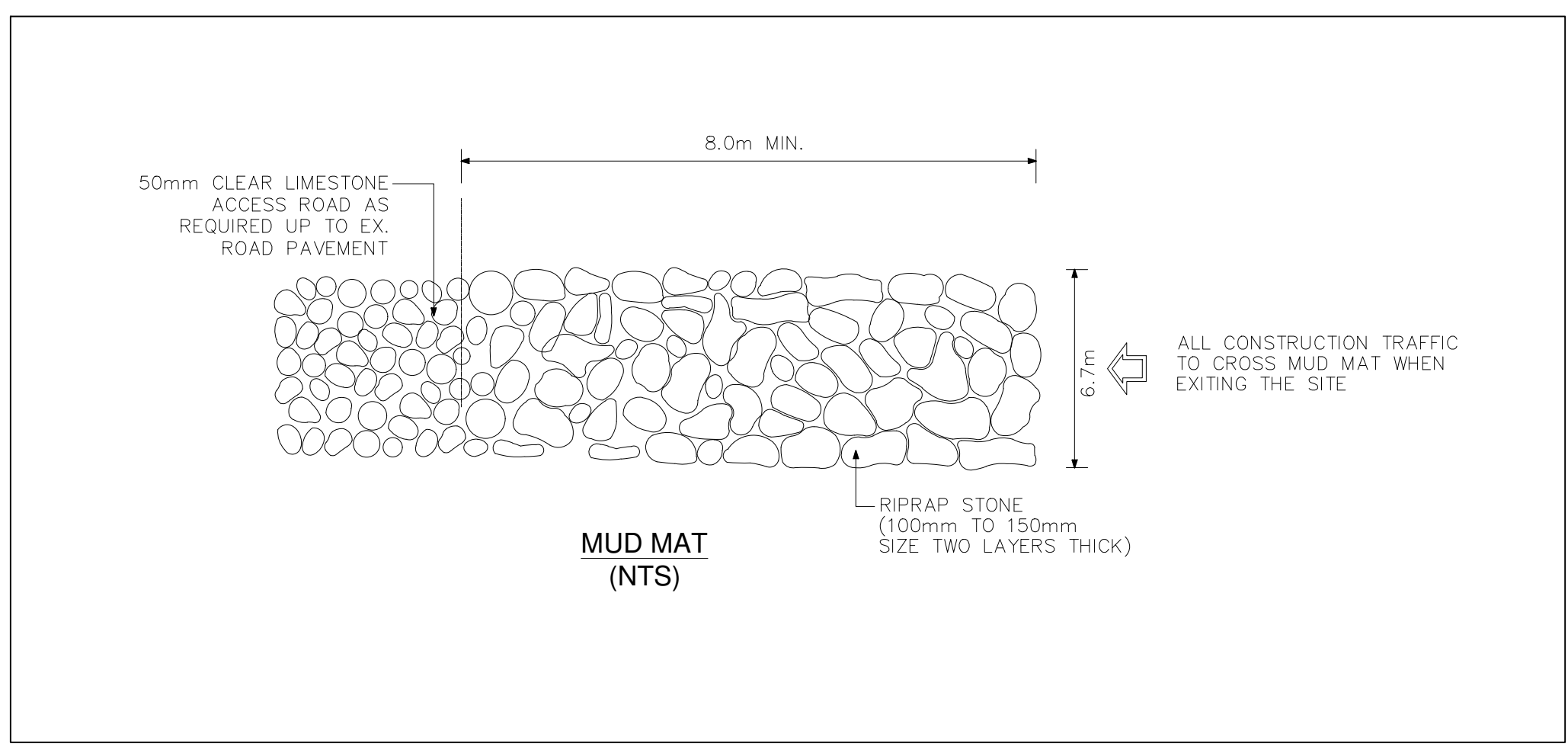
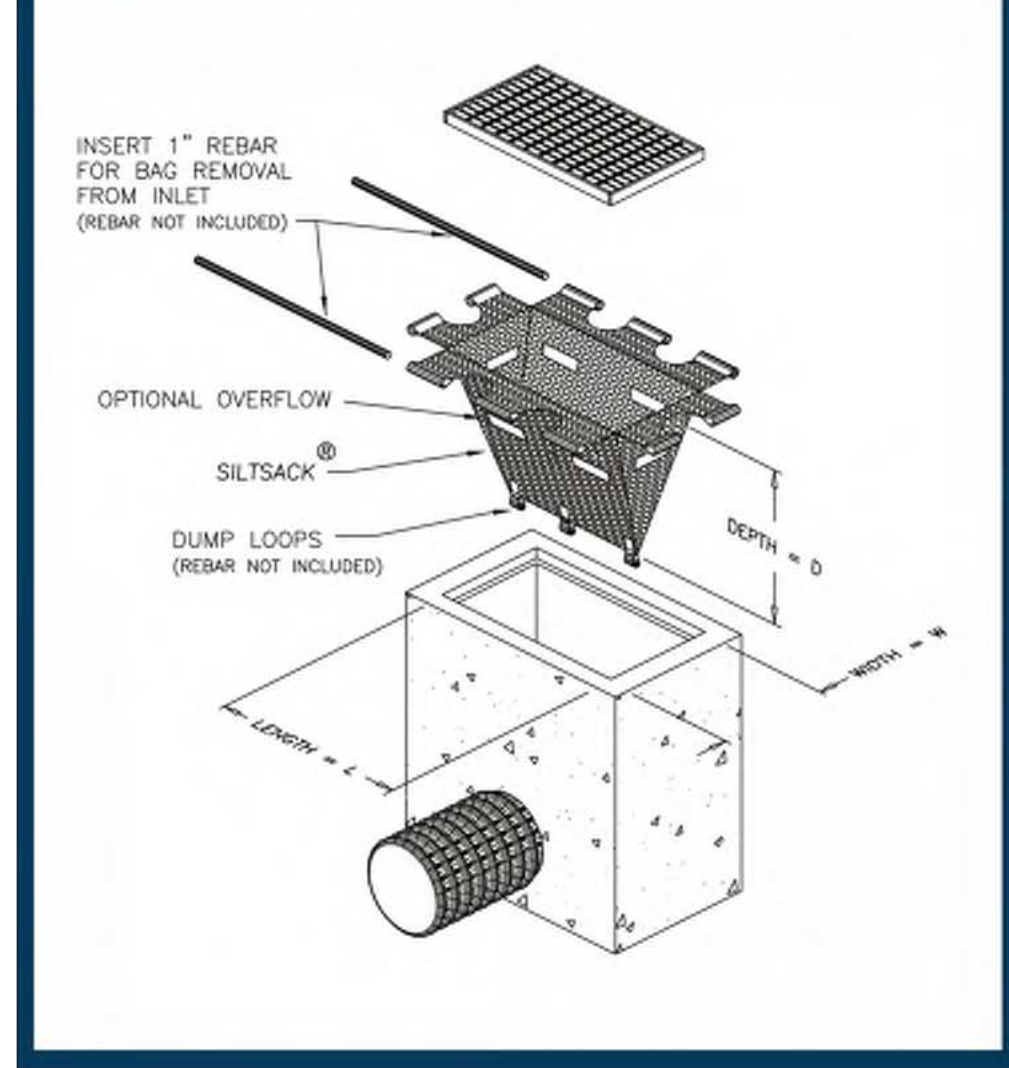

**PROJECT TEAM**

**ARCHITECT**  
 HOBN ARCHITECTURE  
 PAUL KIRKSON  
 905.238.7200

**PLANNING**  
 Q9 Planning + Design  
 Christine McCaig  
 905.850.8343

**CIVIL**  
 WSP  
 STEPHEN McCAIGHEY  
 905.690.3955

**LANDSCAPE ARCHITECT**  
 CSW LANDSCAPE ARCHITECTS LTD.  
 905.729.4536

**TRANSPORTATION**  
 BRG BOLD  
 DAVID HOOK  
 905.225.1311 ext 64029

**ENVIRONMENTAL**  
 GRADIENT WIND ENGINEERING  
 JOSHUA FOSTER  
 905.836.0634

no.	date	revision
4	2021-12-17	ISSUED FOR SPA REVISION 3
3	2021-09-17	ISSUED FOR SPA REVISION 2
2	2021-07-23	ISSUED FOR SPA REVISION 1
1	2021-04-28	ISSUED FOR SPA

It is the responsibility of the appropriate contractor to check and verify all dimensions on site and report all errors and/or omissions to the architect.

All contractors must comply with all pertinent codes and by-laws.

Do not scale drawings.

This drawing may not be used for construction until signed.

Copyright reserved.

**PROJECT LOCATION**  
 100 BAYSHORE LOT "B"  
 WOODRIDGE CRESCENT

**DRAWING TITLE**  
 EROSION AND SEDIMENT CONTROL PLAN

<b>DRAWN BY:</b> BN / SM	<b>DATE:</b> DEC 17, 2021	<b>SCALE:</b> AS NOTED
<b>PROJECT:</b> 211-02810-00		
<b>DRAWING NO.:</b> C004		
<b>REVISION NO.:</b>		

D07-12-21-005



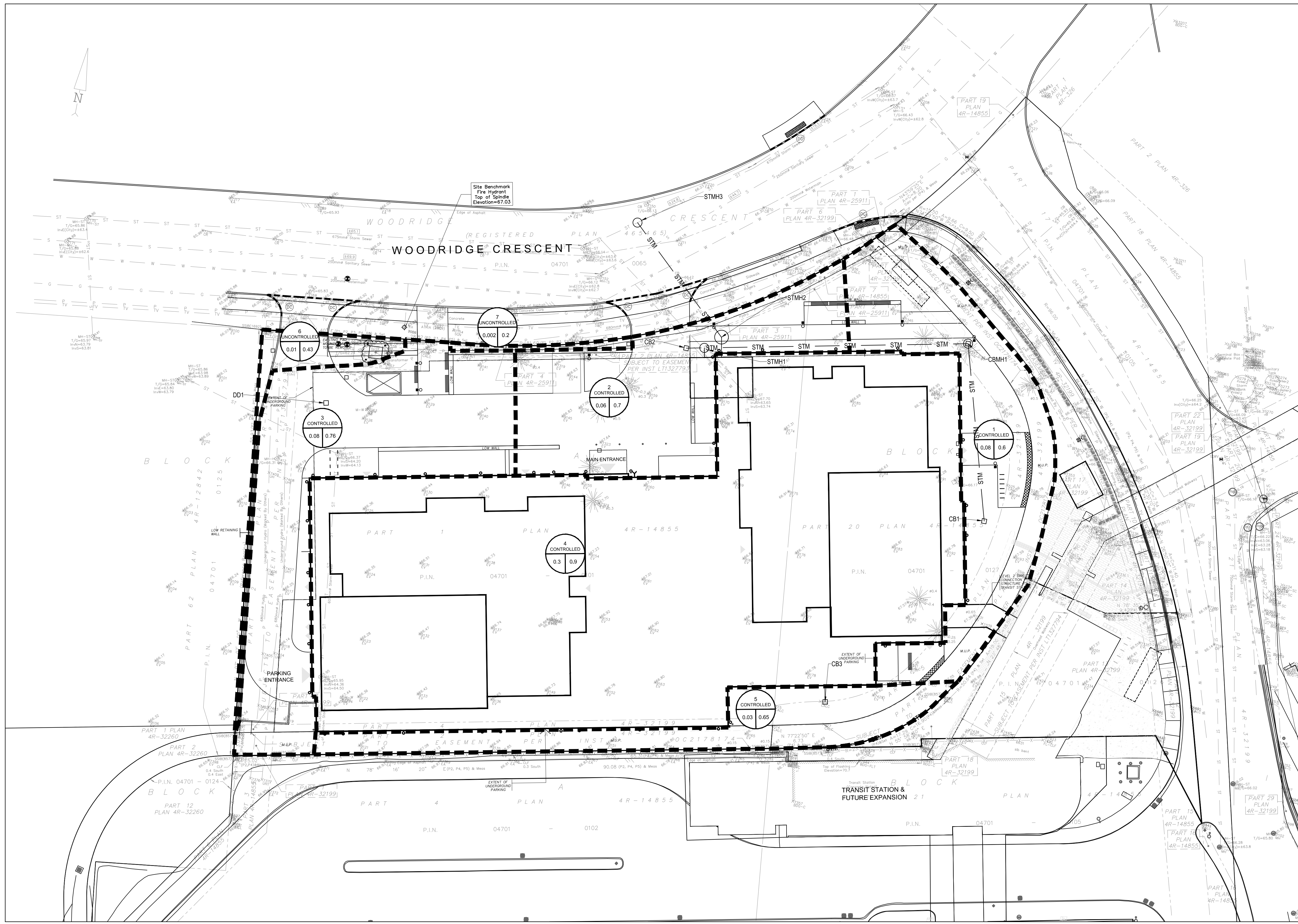

**LEGEND**

- ⊗ 66.50 PROPOSED GRADE ELEVATION
- ⊗ 66.50/0 PROPOSED TOP AND BOTTOM OF CURB
- STMH PROPOSED STORM SEWER MANHOLE
- SAMH PROPOSED SANITARY SEWER MANHOLE
- ⊗ CBMH PROPOSED CATCHBASIN MANHOLE
- CB PROPOSED CATCHBASIN
- STM PROPOSED STORM SEWER
- SAN PROPOSED SANITARY SEWER
- W PROPOSED WATER SERVICE LINE
- ⊕ PROPOSED VALVE BOX
- ▽ PROPOSED REDUCER
- ⊕ FH PROPOSED FIRE HYDRANT
- DC PROPOSED DEPRESSED CURB
- X SERVICES TO BE REMOVED
- ⊗ 65.96 EXISTING GRADE ELEVATION
- ⊗ MH EXISTING MANHOLE
- ⊗ CB EXISTING CATCHBASIN
- ⊗ VB EXISTING VALVE & BOX
- ⊗ FH EXISTING FIRE HYDRANT
- STM EXISTING STORM SEWER
- SAN EXISTING SANITARY SEWER
- W EXISTING WATERMAIN
- G EXISTING GASMAIN
- TV EXISTING CABLE
- P EXISTING HYDRO
- DRAINAGE AREA BOUNDARY
- ⊗ 1 CONTROLLED DRAINAGE AREA
- ⊗ A(a) C

1 STORM DRAINAGE AREA PLAN  
C005 SCALE= 1:250

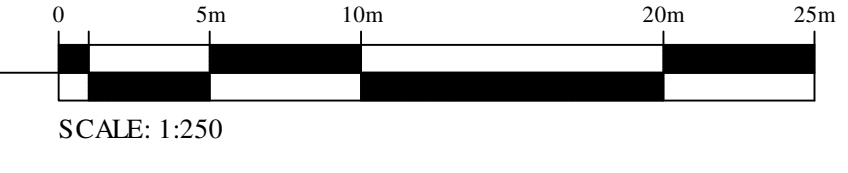

**PROJECT TEAM**

**ARCHITECT**  
HOBBS ARCHITECTURE  
PAUL KIRKSON  
B13.238.7200

**PLANNING**  
Q9 Planning + Design  
Christine McCaugh  
B13.850.8343

**CIVIL**  
WSP  
STEPHEN McCAUGHEY  
B13.690.3955

**LANDSCAPE ARCHITECT**  
CSW LANDSCAPE ARCHITECTS LTD.  
B13.729.4538

**INSURANCE**  
REGROUP  
DAVID HOOK  
B13.225.1311 ext: 64029

**ENVIRONMENTAL**  
GRADIENT WIND ENGINEERING  
JOSHUA FOSTER  
B13.836.0634

no.	date	revision
3	2021-12-17	ISSUED FOR SPA REVISION 3
2	2021-09-17	ISSUED FOR SPA REVISION 2
1	2021-07-23	ISSUED FOR SPA REVISION 1

It is the responsibility of the appropriate contractor to check and verify all dimensions on site and report all errors and/or omissions to the architect.

All contractors must comply with all pertinent codes and by-laws.

Do not scale drawings.

This drawing may not be used for construction until signed.

Copyright reserved.

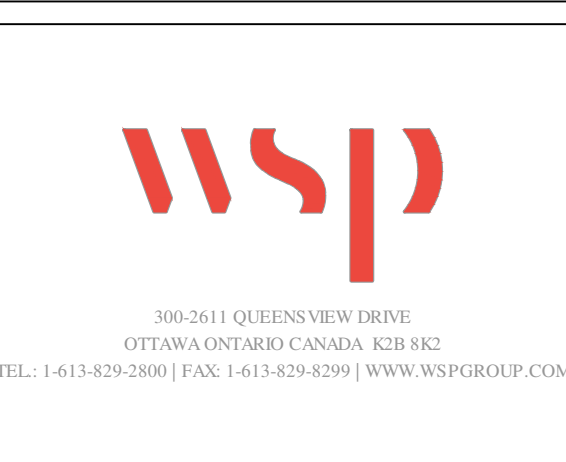

**PROJECT LOCATION**

100 BAYSHORE LOT "B"  
WOODRIDGE CRESCENT

**DRAWING TITLE**

STORM DRAINAGE AREA PLAN

<b>DRAWN BY:</b> BN / SM	<b>DATE:</b> DEC 17, 2021	<b>SCALE:</b> AS NOTED
<b>PROJECT:</b> 211-02810-00		
<b>DRAWING NO.:</b> C005		
<b>REVISION NO.:</b>		

D07-12-21-005



# D STORM SEWER DESIGN SHEET

**WSP Canada**  
Storm Sewer Design Sheet

LOCATION			FLOW									PIPE						MANHOLE					
Catchment Area	FROM MH	TO MH	Coefficient	Area (m2)	Indiv. 2.78*AC	Cum. 2.78*AC	Time of Conc. (min.)	Rainfall Intensity (mm.hr)	Indiv. Area Flow (L/s)	Cum. Flow (L/s)	Controlled Cum. Flow (L/s)	Length (m)	Dia. (mm)	Slope (%)	Cap. (Full) (L/s)	Velocity (Full) (m/s)	Time of flow (min.)	Ratio (Q/Qfull)	UP INVERT (m)	DOWN INVERT (m)			
1	CBMH1	STMH1	0.6	675	0.109	0.109	10.00	76.81	8.36	8.36	8.36	34.4	250	0.52%	43.02	0.9	0.65	19%	64.72	64.54			
2	CB2	STMH1	0.7	610	0.119	0.119	10.00	76.81	9.12	9.12	9.12	2.0	250	1.00%	59.47	1.2	0.03	15%	64.56	64.54			
	STMH1	BLDG*	0.0	0	0.000	0.228	10.33	75.57	0.00	17.20	17.20	2.0	250	1.50%	72.83	1.5	0.02	24%	64.48	64.45			
3, 4 & 5	BLDG*	STMH2**	0.9	4255	1.012	1.240	10.06	76.56	77.51	94.93	20.00	1.5	100	3.33%	9.43	1.2	0.02	212%	63.79	63.74			
	STMH2**	STMH3	0.0	0	0.000	1.240	10.00	76.81	0.00	95.24	20.00	5.5	375	1.09%	183.13	1.7	0.06	11%	63.71	63.65			
DESIGN PARAMETERS								Designed:				PROJECT:											
Q = 2.78CIA where, Q = Peak flow in L/s A = Drainage area in ha I = Rainfall intensity (mm/hr) C = Runoff coefficient								Ottawa IDF Curve IDF Curve Equation (2yr storm) $I = 732.951/(T+6.199)^{0.81}$ Min. velocity = 0.8 m/s Manning 'n' = 0.013				Stephen McCaughey, P.Eng.				100 Bayshore Lot "B"							
								Checked:				LOCATION:											
								Ishaque Jafferjee, P.Eng.				100 Bayshore Lot "B", Ottawa											
								Dwg. Reference:				File Ref.:		Date:		Sheet No.							
												211-02810-00		Dec 2021		1 of 3							

Note:  
 \* Roof drains, deck drains and CB3 to cistern in building footprint. Sump pumps in cistern, forcemain discharge to STMH2 at max rate of 20 L/s  
 \*\* Oil Grit Separator

0.81

**WSP Canada**  
Storm Sewer Design Sheet

LOCATION			FLOW									PIPE						MANHOLE					
Catchment Area	FROM MH	TO MH	Coefficient	Area (m2)	Indiv. 2.78*AC	Cum. 2.78*AC	Time of Conc. (min.)	Rainfall Intensity (mm.hr)	Indiv. Area Flow (L/s)	Cum. Flow (L/s)	Controlled Cum. Flow (L/s)	Length (m)	Dia. (mm)	Slope (%)	Cap. (Full) (L/s)	Velocity (Full) (m/s)	Time of flow (min.)	Ratio (Q/Qfull)	UP INVERT (m)	DOWN INVERT (m)			
1	CBMH1	STMH1	0.7	675	0.136	0.136	10.00	178.56	24.29	24.29	24.29	34.40	250	0.52%	43.02	0.9	0.65	56%	64.72	64.54			
2	CB2	STMH1	0.9	610	0.148	0.148	10.00	178.56	26.50	26.50	26.50	2.00	250	1.00%	59.47	1.2	0.03	45%	64.56	64.54			
	STMH1	BLDG*	0.0	0	0.000	0.284	10.33	175.62	0.00	49.95	49.95	2.00	250	1.50%	72.83	1.5	0.02	69%	64.48	64.45			
3, 4 & 5	BLDG*	STMH2**	1.0	4255	1.183	1.467	10.07	177.94	210.49	261.10	20.00	1.50	100	3.33%	9.43	1.2	0.02	212%	63.79	63.74			
	STMH2**	STMH3	0.0	0	0.000	1.467	10.00	178.56	0.00	262.00	20.00	5.50	375	1.09%	183.13	1.7	0.06	11%	63.71	63.65			
DESIGN PARAMETERS								Designed:				PROJECT:											
Q = 2.78CIA where, Q = Peak flow in L/s A = Drainage area in ha I = Rainfall intensity (mm/hr) C = Runoff coefficient								Ottawa IDF Curve IDF Curve Equation (100yr storm) $I = 1735.688 / (T + 6.014)^{0.82}$ Min. velocity = 0.8 m/s Manning 'n' = 0.013				Stephen McCaughey, P.Eng.				100 Bayshore Lot "B"							
								Checked:				LOCATION:											
								Ishaque Jafferjee, P.Eng.				100 Bayshore Lot "B", Ottawa											
								Dwg. Reference:				File Ref.:		Date:		Sheet No.							
												211-02810-00		Dec 2021		2 of 3							

Note:  
 \* Roof drains, deck drains and CB3 to cistern in building footprint. Sump pumps in cistern, forcemain discharge to STMH2 at max rate of 20 L/s  
 \*\* Oil Grit Separator

LOCATION			FLOW									PIPE						MANHOLE					
Catchment Area	FROM MH	TO MH	Coefficient	Area (m2)	Indiv. 2.78*AC	Cum. 2.78*AC	Time of Conc. (min.)	Rainfall Intensity + 20% (mm.hr)	Indiv. Area Flow (L/s)	Cum. Flow (L/s)	Controlled Cum. Flow (L/s)	Length (m)	Dia. (mm)	Slope (%)	Cap. (Full) (L/s)	Velocity (Full) (m/s)	Time of flow (min.)	Ratio (Q/Qfull)	UP INVERT (m)	DOWN INVERT (m)			
1	CBMH1	STMH1	0.7	675	0.136	0.136	10.00	214.27	29.15	29.15	29.15	34.40	250	0.52%	43.02	0.9	0.65	68%	64.72	64.54			
2	CB2	STMH1	0.9	610	0.148	0.148	10.00	214.27	31.79	31.79	31.79	2.00	250	1.00%	59.47	1.2	0.03	53%	64.56	64.54			
	STMH1	BLDG*	0.0	0	0.000	0.284	10.33	210.75	0.00	59.94	59.94	2.00	250	1.50%	72.83	1.5	0.02	82%	64.48	64.45			
3, 4 & 5	BLDG*	STMH2**	1.0	4255	1.183	1.467	10.07	213.53	252.58	313.32	20.00	1.50	100	3.33%	9.43	1.2	0.02	212%	63.79	63.74			
	STMH2**	STMH3	0.0	0	0.000	1.467	10.00	214.27	0.00	314.40	20.00	5.50	375	1.09%	183.13	1.7	0.06	11%	63.71	63.65			
DESIGN PARAMETERS								Designed:				PROJECT:											
Q = 2.78CIA where, Q = Peak flow in L/s A = Drainage area in ha I = Rainfall intensity (mm/hr) C = Runoff coefficient								Ottawa IDF Curve IDF Curve Equation (100yr storm) $I = 1735.688 / (T + 6.014)^{0.82}$ Min. velocity = 0.8 m/s Manning 'n' = 0.013				Stephen McCaughey, P.Eng.				100 Bayshore Lot "B"							
								Checked:				LOCATION:											
								Ishaque Jafferjee, P.Eng.				100 Bayshore Lot "B", Ottawa											
								Dwg. Reference:				File Ref.:		Date:		Sheet No.							
												211-02810-00		Dec 2021		3 of 3							

Note:  
 \* Roof drains, deck drains and CB3 to cistern in building footprint. Sump pumps in cistern, forcemain discharge to STMH2 at max rate of 20 L/s  
 \*\* Oil Grit Separator

**STORAGE VOLUME REQUIRED (2-YEAR and 100-YEAR STORMS)**

$C_{AVG} = 0.81$  (2-year)  
 $C_{AVG} = 1.00$  (100-year)  
 Time Interval = 5 (mins)  
 Drainage Area = 0.55400 (hectares)

Release Rate =  $\frac{20.0}{1}$  (L/sec)  
 Return Period = 2 (years)  
 IDF Parameters,  $A = \frac{732.951}{(I = A/(T_c+C))}$ ,  $B = 0.810$ ,  $C = 6.199$

Release Rate =  $\frac{20.0}{1}$  (L/sec)  
 Return Period = 100 (years)  
 IDF Parameters,  $A = \frac{1735.69}{(I = A/(T_c+C))}$ ,  $B = 0.820$ ,  $C = 6.014$

Time (min)	Intensity, I (mm/hr)	Peak Flow (L/s)	Release Rate (L/s)	Storage Rate (L/s)	Storage Volume (m <sup>3</sup> )	Intensity, I (mm/hr)	Peak Flow (L/s)	Release Rate (L/s)	Storage Rate (L/s)	Storage Volume (m <sup>3</sup> )
0	167.2	207.4	20.0	187.4	0.00	398.6	613.9	20.0	593.9	0.00
5	103.6	128.4	20.0	108.4	32.53	242.7	373.8	20.0	353.8	106.14
10	76.8	95.2	20.0	75.2	45.14	178.6	275.0	20.0	255.0	153.00
15	61.8	76.6	20.0	56.6	50.93	142.9	220.1	20.0	200.1	180.07
20	52.0	64.5	20.0	44.5	53.42	120.0	184.7	20.0	164.7	197.69
25	45.2	56.0	20.0	36.0	54.01	103.8	159.9	20.0	139.9	209.91
30	40.0	49.7	20.0	29.7	53.38	91.9	141.5	20.0	121.5	218.68
35	36.1	44.7	20.0	24.7	51.90	82.6	127.2	20.0	107.2	225.08
40	32.9	40.8	20.0	20.8	49.80	75.1	115.7	20.0	95.7	229.76
45	30.2	37.5	20.0	17.5	47.24	69.1	106.3	20.0	86.3	233.13
50	28.0	34.8	20.0	14.8	44.31	64.0	98.5	20.0	78.5	235.49
55	26.2	32.5	20.0	12.5	41.09	59.6	91.8	20.0	71.8	237.03
60	24.6	30.5	20.0	10.5	37.62	55.9	86.1	20.0	66.1	237.90
65	23.2	28.7	20.0	8.7	33.96	52.6	81.1	20.0	61.1	238.22
70	21.9	27.2	20.0	7.2	30.12	49.8	76.7	20.0	56.7	238.06
75	20.8	25.8	20.0	5.8	26.14	47.3	72.8	20.0	52.8	237.51
80	19.8	24.6	20.0	4.6	22.03	45.0	69.3	20.0	49.3	236.60
85	18.9	23.5	20.0	3.5	17.80	43.0	66.2	20.0	46.2	235.39
90	18.1	22.5	20.0	2.5	13.48	41.1	63.3	20.0	43.3	233.91
95	17.4	21.6	20.0	1.6	9.08	39.4	60.7	20.0	40.7	232.18
100	16.7	20.8	20.0	0.8	4.59	37.9	58.4	20.0	38.4	230.25
105	16.1	20.0	20.0	0.0	0.04	36.5	56.2	20.0	36.2	228.13
110	15.6	19.3	20.0	-0.7	-4.58	35.2	54.2	20.0	34.2	225.83
115	15.0	18.7	20.0	-1.3	-9.26	34.0	52.4	20.0	32.4	223.37
120	14.6	18.1	20.0	-1.9	-13.99	32.9	50.7	20.0	30.7	220.77

Max = **54.01** **238.22**

**Notes**

- 1) Peak flow is equal to  $2.78 \times C \times I \times A$
- 2) Intensity,  $I = A/(T_c+C)^B$
- 3) Release Rate = Min (Release Rate, Peak Flow)
- 4) Storage Rate = Peak Flow - Release Rate
- 5) Storage = Time x Storage Rate
- 6) Maximum Storage = Max Storage Over Time



# **E** CORRESPONDENCES

## McCaughey, Stephen

---

**Subject:** FW: Pre-Consultation Follow-Up: 100 Bayshore Drive  
**Attachments:** Plans & Study List.pdf; design\_brief\_TOR\_100 Bayshore.pdf

**From:** "McCreight, Laurel" <[Laurel.McCreight@ottawa.ca](mailto:Laurel.McCreight@ottawa.ca)>  
**Date:** March 3, 2021 at 9:55:19 AM EST  
**To:** Christine McCuaig <[christine@q9planning.com](mailto:christine@q9planning.com)>  
**Subject:** Pre-Consultation Follow-Up: 100 Bayshore Drive

Hi Christine,

Please refer to the below regarding the Pre-Application for 100 Bayshore Drive for a Site Plan Control Application for a residential development containing two high-rise towers. I have also attached the required Plans & Study List for application submission.

Below are staff's preliminary comments based on the information available at the time of the pre-consultation meeting:

### **Planning / Urban Design**

- A Design Brief is required for the site plan control application. The Terms of Reference is attached for convenience.
  - Please note a secondary wind study is required for the application. Please refer to the [Terms of Reference of the wind study](#) for details.
  - The preliminary wind study prepared for the OPA and rezoning identifies a number of areas that will experience rather windy conditions.
  - The detailed design should respond and mitigate such conditions to the extent possible.
  - The secondary wind study should confirm the adequacy of the design measures.
- The site is not within a Design Priority Area. However, as identified in the zoning exception, the applicant is required to visit the Urban Design Review Panel (UDRP) for formal approval.
- Please contact [udrp@ottawa.ca](mailto:udrp@ottawa.ca) for any questions regarding UDRP.
- Regarding the detailed design:
  - Please investigate possible architectural and landscaping measures to mitigate wind impacts/improve conditions in the public realm as well as at the roof top patio.
    - Some refined sculpting at the building corners and Tower A may be helpful.
  - The front yard of the site should be designed as a welcoming pedestrian forecourt through landscaping details where vehicular functions are accommodated but not dominating.
    - Considerations should be given to paving the entire area with interlocks, using depressed curbs, and locating parking only on one side of the central pedestrian walkway.
  - The entrances of both towers should be treated equally within the pedestrian forecourt through landscape design.
  - Please provide details of the parking lot screens.
  - Considerations may be given to refining the building facades to display some commercial characteristics.
  - Considerations should be given to exterior lighting.
- Cash-in-lieu of Parkland will be required.
- Please consult the new [Draft Official Plan](#) for emerging directions.

- Please refer to the recently approved [Bird-Friendly Design Guidelines](#).
- LRT Proximity Study – Confirm details with File Lead prior to application submission. In process of reviewing Stage 2 requirements.
- You are encouraged to contact the Ward Councillor, Councillor [Theresa Kavanagh](#), about the proposal.
  - It is recommended to reach out to the Councillor to discuss the working group as required per the direction of Council.
  - I would be happy to attend this meeting as well.

### **Engineering**

- All exterior light fixtures must be included and approved as part of the site plan approval. Therefore, the lights must be clearly identified by make, model and part number. All external light fixtures must meet the criteria for full cut-off classification as recognized by the Illuminating Engineering Society of North America (IESNA or IES), and must result in minimal light spillage onto adjacent properties (as a guideline, 0.5 fc is normally the maximum allowable spillage). In order to satisfy these criteria, the applicant must provide certification from an acceptable professional engineer. The location of all exterior fixtures, a table showing the fixture types (including make, model, part number), and the mounting heights must be included on a plan

Servicing and site works shall be in accordance with the following documents:

- Ottawa Sewer Design Guidelines (October 2012)
- Ottawa Design Guidelines – Water Distribution (2010)
- Geotechnical Investigation and Reporting Guidelines for Development Applications in the City of Ottawa (2007)
- City of Ottawa Slope Stability Guidelines for Development Applications (revised 2012)
- City of Ottawa Environmental Noise Control Guidelines (January, 2016)
- City of Ottawa Park and Pathway Development Manual (2012)
- City of Ottawa Accessibility Design Standards (2012)
- Ottawa Standard Tender Documents (latest version)
- Ontario Provincial Standards for Roads & Public Works (2013)

Record drawings and utility plans are also available for purchase from the City (Contact the City's Information Centre by email at [InformationCentre@ottawa.ca](mailto:InformationCentre@ottawa.ca) or by phone at (613) 580- 2424 x.44455).

The Stormwater Management Criteria, for the subject site, is to be based on the following:

The IDF information derived from the Meteorological Services of Canada rainfall data, taken from the MacDonald Cartier Airport, collected 1966 to 1997.

The existing storm system in the RoW was built pre-1970, as such the post-development peak flow rate for storm events up to and including the 100 year event will need to be controlled to the 2 year pre-development storm event. Runoff will need to be detained onsite to control all storm events, up to and including the 100 year event, with an allowable release rate calculated based on the peak flow for the pre-development 2 year event.

The pre-development runoff coefficient or a maximum equivalent 'C' of 0.5, whichever is less (§ 8.3.7.3).

A calculated time of concentration (cannot be less than 10 minutes).

Redevelopment will be expected to provide water quality protection at an enhanced level (minimum 80% TSS removal), as per the RVCA.

The proposed sanitary flows need to be provided to the City to confirm capacity / identify the impact on the downstream West Nepean Collector.

Deep Services (Storm, Sanitary & Water Supply)

Provide existing servicing information and the recommended location for the proposed connections. Services should ideally be grouped in a common trench to minimize the number of road cuts.

Connections to trunk sewers and easement sewers are typically not permitted.

Provide information on the monitoring manhole requirements – should be located in an accessible location on private property near the property line (ie. Not in a parking area).

Review provision of a high-level sewer.

Provide information on the type of connection permitted

Sewer connections to be made above the springline of the sewermain as per:

Std Dwg S11.1 for flexible main sewers – connections made using approved tee or wye fittings.

Std Dwg S11 (For rigid main sewers) – lateral must be less than 50% the diameter of the sewermain,

Std Dwg S11.2 (for rigid main sewers using bell end insert method) – for larger diameter laterals where manufactured inserts are not available; lateral must be less than 50% the diameter of the sewermain,

Connections to manholes permitted when the connection is to rigid main sewers where the lateral exceeds 50% the diameter of the sewermain. – Connect obvert to obvert with the outlet pipe unless pipes are a similar size.

No submerged outlet connections.

Please refer to ISDTB – 2014-2: individual residential facilities with a basic day demand greater than 50 m<sup>3</sup>/day shall be connected with a minimum of two water services, separated by an isolation valve, to avoid the creation of a vulnerable service area.

Water Boundary condition requests must include the location of the service and the expected loads required by the proposed development. Please provide the following information:

Location of service

Type of development and the amount of fire flow required (as per FUS, 1999).

Average daily demand: \_\_\_\_ l/s.

Maximum daily demand: \_\_\_\_ l/s.

Maximum hourly daily demand: \_\_\_\_ l/s.

Note that if Accora Village is proposed to re-develop in its entirety, the proponent may be required to (or may consider) modelling the loop along Woodridge Crescent to provide sub-division level details above.

Phase 1 ESAs and Phase 2 ESAs must conform to clause 4.8.4 of the Official Plan that requires that development applications conform to Ontario Regulation 153/04.

Please refer to Ontario Regulation 153/04:

“the date the last work on all of the records review, interviews and site reconnaissance required for the phase one environmental site assessment that is the subject of the report was done is no later than 18 months before the submission of the record of site condition or the commencement of the phase two environmental site assessment” and

“the date the last work on all of the planning the site investigation, conducting the site investigation and reviewing and evaluating the information gathered through the site investigation required for the phase two environmental site assessment that is the subject of the report was done is no later than 18 months before the submission of the record of site condition or the commencement of the risk assessment”.

#### MOECC ECA Requirements

Please note that an ECA is not required for zoning amendment however the following applies to the Site Plan Control process:

An MOECC Environmental Compliance Approval (Municipal/Private Sewage Works) will be required for the proposed development where the storm sewer network is designed to service more than one lot or parcel of land. The proposed development boundary appears to include two parcels of land.

Although not required for the rezoning amendment, please note that for Site Plan Control, there is an existing public STM sewer running through the site. Please identify the easement associated with this sewer and provide details of how this will be taken into consideration in the proposed design.

Although not required for the rezoning amendment, please note that for Site Plan Control, please ensure that all easements within the property and adjacent to the subject property are identified on the drawing set and please provide details for all easements identified.

Please contact Infrastructure Project Manager [Ahmed Elsayed](#) for follow-up questions.

#### **Transportation**

- Please submit an addendum/memo to the Transportation Impact Assessment previously provided.
- A noise study is required.

Please contact Transportation Project Manager, [Mike Giampa](#) for follow-up questions.

#### **Other**

Please refer to the links to “[Guide to preparing studies and plans](#)” and [fees](#) for general information. Additional information is available related to [building permits, development charges, and the Accessibility Design Standards](#). Be aware that other fees and permits may be required, outside of the development review process. You may obtain background drawings by contacting [informationcentre@ottawa.ca](mailto:informationcentre@ottawa.ca).

These pre-consultation comments are valid for one year. If you submit a development application(s) after this time, you may be required to meet for another pre-consultation meeting and/or the submission requirements may change. You are as well encouraged to contact us for a follow-up meeting if the plan/concept will be further refined.

Please do not hesitate to contact me if you have any questions.

Regards,  
Laurel

**Laurel McCreight MCIP, RPP**  
Planner  
Development Review West  
Urbaniste  
Examen des demandes d'aménagement ouest

City of Ottawa | Ville d'Ottawa

613.580.2424 ext./poste 16587

[ottawa.ca/planning](http://ottawa.ca/planning) / [ottawa.ca/urbanisme](http://ottawa.ca/urbanisme)

This e-mail originates from the City of Ottawa e-mail system. Any distribution, use or copying of this e-mail or the information it contains by other than the intended recipient(s) is unauthorized. Thank you.

Le présent courriel a été expédié par le système de courriels de la Ville d'Ottawa. Toute distribution, utilisation ou reproduction du courriel ou des renseignements qui s'y trouvent par une personne autre que son destinataire prévu est interdite. Je vous remercie de votre collaboration.

### Description:

A Design Brief is the core submission document that illustrates how the development is designed to work with its existing and planned context, to improve its surroundings and also demonstrate how the proposal supports the overall goals of the Official Plan, relevant secondary plans, Council approved plans and design guidelines. The purpose of the Terms of Reference is to assist the applicant to organize and substantiate the design justification in support of the proposed development and to assist staff and the public in the review of the proposal.

### Authority to Request a Design Brief:

The *Planning Act* gives municipalities the authority to require that a Design Brief be prepared. Under Sections 22(4), (5) and Section 41(4) of the *Planning Act*, a Council has the authority to request such other information or material that the authority needs in order to evaluate and make a decision on an application. Section 5.2.6 of the Official Plan sets out the general requirement for a Design Brief.

### Preparation:

The Design Brief should be signed by an urban designer, licenced architect, landscape architect, or a full member of the Canadian Institute of Planners.

### When Required:

A Design Brief is required for a Site Plan Control planning application.

A Scoped Design Brief\* is required when the following planning applications are applied for and not accompanied by a Site Plan Control application:

- Official Plan Amendment
- Zoning By-law Amendment (exception: a change in use which does not result in an increase in height or massing)

The requirement and scope of a Design Brief will be determined at the formal pre-application consultation meeting. Should an application be required to go to the [Urban Design Review Panel \(UDRP\)](#), the Design Brief may be submitted as part of the submission materials to the panel.

### Contents for Design Brief Submissions:

A Design Brief will contain and/or address the points identified during the pre-consultation meeting. Failure to address the critical elements identified in the pre-consultation meeting may result in the application being considered incomplete.

\* A *Scoped Design Brief* is composed of:

- Section 1 should be combined into the *Planning Rationale* submission, and
- Section 2 items will be confirmed in the pre-application consultation meeting.

**SECTION 1** Note: This section will be combined with the Planning Rationale report.

Application Submission:

Not Required

Required

State the: type of application, legal description, municipal address, purpose of the application and provide an overall vision statement and goals for the proposal.

Response to City Documents:

Not Required

Required

State the Official Plan land use designation for the subject property and demonstrate how the proposal conforms to the Official Plan as it relates to the design of the subject site. Reference specific policy numbers from the Official Plan to show consistency. Justify areas of non-compliance and explain why there is non-compliance.



State the applicable plans which apply to the subject proposal: community design plan, secondary plan, concept plan and design guideline. Reference the relevant design related policies within the applicable plans/guidelines and provide a comprehensive analysis as to how the proposed development incorporates the objectives or why it does not incorporate the objectives.

Context Plan:

Not Required

Required

Provide a contextual analysis that discusses/illustrates abutting properties, key destinations and linkages within a 100 meter radius (a larger radius may be requested for larger/more complex projects), such as transit stations, transportation networks for cars, cyclists, and pedestrians, focal points/nodes, gateways; parks/open spaces, topography, views towards the site, the urban pattern (streets, blocks), future and current proposals (if applicable), public art and heritage resources.



Photographs to illustrate existing site conditions and surrounding contexts. Include a map pinpointing (with numbers) where each photo is taken and correspond these numbers with the site photos. Arrows illustrating the direction the photo is taken is also useful.

**Note:**

Although zoning has already been approved, it is still useful include a broader area context in the submission, including pedestrian connections, parks and open spaces, and different uses.



### SECTION 2

#### Design Proposal:

The purpose of the Design Proposal is to show the building elevations, exterior details, transitions in form, treatment of the public realm and compatibility with adjacent buildings, using 3-D models, illustrations, diagrams, plans, and cross sections. Referencing Official Plan, Section 5.2.1, as determined at time of pre-application consultation meeting, submissions will need to address the following in the form of labelled graphics and written explanation:

#### **Massing and Scale**

Not Required      Required

#### *Images which show:*

#### Building massing – from:

- at least two sides set within its current context (showing the entire height and width of the building) **OR**
- all four sides set within its current context (showing the entire height and width of the building).

#### Views – of the entire block, from:

- at least two perspectives to show how the proposed building is set within its current context **OR**
- all four perspectives to show how the proposed building is set within its current context.

Building transition – to adjacent uses, with labelled explanation of the transition measures used.

Grading – if grades are an issue.

Alternative building massing – additional imagery and site layouts considered and provide justification for the ultimate proposal sought.

#### **Public Realm**

Not Required      Required

#### *Labelled graphics and a written explanation which show:*

Streetscape – cross sections which illustrate the street design and right of way (referencing the City's design manuals).

Relationship to the public realm – illustrating how the first few storeys of the proposed development responds to and relates to the existing context (e.g. through a podium plan and first floor plan). This is to include detailed explanation on:

- Architectural responses
- Landscaping details
- Public art features (in accordance with Official Plan, Section 4.11)
- For developments in Design Priority Areas, detail the building and site features, (in accordance with Official Plan, Section 4.11) which will enhance the public realm. Provide explanation for features which are not provided.

### **Building Design**

Not Required

Required

Labelled graphics (e.g. building elevations and floor plans) and a written explanation which document the proposed exterior architectural details and design (in accordance with Official Plan, Section 5.2.1).



For high-rise development applications, detail the building design and massing and scale elements and how they relate to the proposed high-rise development (in accordance with Official Plan, Section 5.2.1).

### **Sustainability**

Not Required

Required

Any sustainable design features to be incorporated, such as green roofs or walls, sun traps, reflective or permeable surfaces.

### **Heritage**

Not Required

Required

How the building relates to the historic details, materials, site and setting of any existing historic resources on or adjacent to the subject property (if applicable).

## **Additional Contents:**

Some proponents may be requested to provide submission material which complements the Design Brief. These additional requirements could be incorporated into the Design Brief submission for ease of review. These will be identified at the time of application consultation meeting:

- X • Site Plan
- X • Landscape Plan
- X • Plan showing existing and proposed servicing
- X • Shadow Analysis
- X • Wind Analysis

## **Submission Requirements**

- Six hard copies and one digital copy

## APPLICANT'S STUDY AND PLAN IDENTIFICATION LIST

Legend: **S** indicates that the study or plan is required with application submission.

**A** indicates that the study or plan may be required to satisfy a condition of approval/draft approval.

For information and guidance on preparing required studies and plans refer [here](#):

S/A	Number of copies	ENGINEERING		S/A	Number of copies
<b>S</b>	<b>3</b>	1. Site Servicing Plan	2. Site Servicing Study	<b>S</b>	<b>3</b>
<b>S</b>	<b>3</b>	3. Grade Control and Drainage Plan	4. Geotechnical Study	<b>S</b>	<b>3</b>
■	2	5. Composite Utility Plan	6. Groundwater Impact Study	■	3
■	3	7. Servicing Options Report	8. Wellhead Protection Study	■	3
<b>S</b>	<b>4</b>	9. Transportation Impact Assessment (TIA)	10. Erosion and Sediment Control Plan	<b>S</b>	<b>3</b>
<b>S</b>	<b>3</b>	11. Storm water Management Report	12. Hydro geological and Terrain Analysis	■	3
<b>S</b>	3	13. Water Main Protection and Contingency Plan	14. Noise and vibration Study	<b>S</b>	<b>3</b>
■	PDF only	15. Roadway Modification Functional Design	16. LRT Proximity Study	<b>S</b>	<b>3</b>

S/A	Number of copies	PLANNING / DESIGN / SURVEY		S/A	Number of copies
■	15	17. Draft Plan of Subdivision	18. Plan Showing Layout of Parking Garage	<b>S</b>	<b>2</b>
■	5	19. Draft Plan of Condominium	20. Planning Rationale	<b>S</b>	<b>3</b>
<b>S</b>	<b>10</b>	21. Site Plan	22. Minimum Distance Separation (MDS)	■	3
■	15	23. Concept Plan Showing Proposed Land Uses and Landscaping	24. Agrology and Soil Capability Study	■	3
■	3	25. Concept Plan Showing Ultimate Use of Land	26. Cultural Heritage Impact Statement	■	3
<b>S</b>	<b>3</b>	27. Landscape Plan	28. Archaeological Resource Assessment Requirements: <b>S</b> (site plan) <b>A</b> (subdivision, condo)	■	3
<b>S</b>	<b>1</b>	29. Survey Plan	30. Shadow Analysis	<b>S</b>	<b>3</b>
<b>S</b>	<b>3</b>	31. Architectural Building Elevation Drawings (dimensioned)	32. Design Brief (includes the Design Review Panel Submission Requirements)	<b>S</b>	Available online
<b>S</b>	<b>3</b>	33. Wind Analysis		■	

S/A	Number of copies	ENVIRONMENTAL		S/A	Number of copies
<b>S</b>	<b>3</b>	34. Phase 1 Environmental Site Assessment	35. Impact Assessment of Adjacent Waste Disposal/Former Landfill Site	■	3
<b>S</b>	<b>3</b>	36. Phase 2 Environmental Site Assessment (depends on the outcome of Phase 1)	37. Assessment of Landform Features	■	3
<b>S</b>	<b>3</b>	38. Record of Site Condition (condition of Site Plan)	39. Mineral Resource Impact Assessment	■	3
	3	40. Tree Conservation Report	41. Environmental Impact Statement / Impact Assessment of Endangered Species	■	3
■	3	42. Mine Hazard Study / Abandoned Pit or Quarry Study	43. Integrated Environmental Review (Draft, as part of Planning Rationale)	■	3

S/A	Number of copies	ADDITIONAL REQUIREMENTS		S/A	Number of copies
<b>S</b>	<b>1</b>	44. Applicant's Public Consultation Strategy (may be provided as part of the Planning Rationale)	45. Site Lighting Plan & Certificate	<b>S</b>	<b>1</b>

Meeting Date: February 17, 2021

Application Type: *Site Plan Control*

File Lead (Assigned Planner): Laurel McCreight

Infrastructure Approvals PM: Ahmed Elsayed

Site Address (Municipal Address): 100 Bayshore Drive \*Preliminary Assessment: 1  2  3  4  5

\*One (1) indicates that considerable major revisions are required before a planning application is submitted, while five (5) suggests that proposal appears to meet the City's key land use policies and guidelines. **This assessment is purely advisory and does not consider technical aspects of the proposal or in any way guarantee application approval.**

**It is important to note that the need for additional studies and plans may result during application review. If following the submission of your application, it is determined that material that is not identified in this checklist is required to achieve complete application status, in accordance with the Planning Act and Official Plan requirements, the Planning, Infrastructure and Economic Development Department will notify you of outstanding material required within the required 30 day period. Mandatory pre-application consultation will not shorten the City's standard processing timelines, or guarantee that an application will be approved. It is intended to help educate and inform the applicant about submission requirements as well as municipal processes, policies, and key issues in advance of submitting a formal development application. This list is valid for one year following the meeting date. If the application is not submitted within this timeframe the applicant must again pre-consult with the Planning, Infrastructure and Economic Development Department.**

## McCaughey, Stephen

---

**From:** Elsayed, Ahmed <ahmed.elsayed@ottawa.ca>  
**Sent:** Monday, March 15, 2021 10:20 AM  
**To:** McCaughey, Stephen  
**Cc:** McCreight, Laurel  
**Subject:** RE: 100 Bayshore Drive - Inquiries for Site Plan Application

Hi Stephen,

Thanks for your follow up, about the Sanitary, there is no issue with the flows shown below, as for water, it takes 10 business days for IPU to get to us.

I will keep you posted.

Ahmed

---

**From:** McCaughey, Stephen <Stephen.Mccaughey@wsp.com>  
**Sent:** Monday, March 15, 2021 9:38 AM  
**To:** Elsayed, Ahmed <ahmed.elsayed@ottawa.ca>  
**Cc:** McCreight, Laurel <Laurel.McCreight@ottawa.ca>  
**Subject:** FW: 100 Bayshore Drive - Inquiries for Site Plan Application

**CAUTION: This email originated from an External Sender. Please do not click links or open attachments unless you recognize the source.**

**ATTENTION : Ce courriel provient d'un expéditeur externe. Ne cliquez sur aucun lien et n'ouvrez pas de pièce jointe, excepté si vous connaissez l'expéditeur.**

Hi Ahmed,

Just touching base from my inquiry last Monday, are there any questions or further information you need for water boundary conditions and sanitary capacity?

Thank you,

**Stephen McCaughey, P.Eng.**  
T +1 613-690-3955 (Direct)  
T +1 613-829-2800 (Office)



---

**From:** McCaughey, Stephen  
**Sent:** Monday, March 08, 2021 2:38 PM  
**To:** [ahmed.elsayed@ottawa.ca](mailto:ahmed.elsayed@ottawa.ca)  
**Subject:** 100 Bayshore Drive - Inquiries for Site Plan Application

Hi Ahmed,

Wanted to inquire regarding civil servicing capacity for this 100 Bayshore Dr. site we had a pre-consultation meeting with Laurel McCreight on.

Water Boundary condition requests must include the location of the service and the expected loads required by the proposed development. Please provide the following information:

Location of service **see attached (note conceptual servicing using older architectural site plan for reference, proposed location of services however is still valid)**

Type of development and the amount of fire flow required (as per FUS, 1999). **8,000 L/min (133 L/s) based on letter from the Architect confirming fire resistive construction. This justification was previously presented for the site with the rezoning application.**

Average daily demand: 2.86 l/s.

Maximum daily demand: 7.15 l/s.

Maximum hourly daily demand: 15.72 l/s.

The proposed sanitary flows need to be provided to the City to confirm capacity / identify the impact on the downstream West Nepean Collector.

**Peak sanitary 9.92 L/s**

Thank you and let me know if there are any questions,

**Stephen McCaughey, P.Eng.**

Project Engineer  
Municipal Infrastructure



T +1 613-690-3955 (Direct)  
T +1 613-829-2800 (Office)

300-2611 Queensview Drive  
Ottawa, Ontario  
K2B 8K2 Canada

**wsp.com**

---

NOTICE: This communication and any attachments ("this message") may contain information which is privileged, confidential, proprietary or otherwise subject to restricted disclosure under applicable law. This message is for the sole use of the intended recipient(s). Any unauthorized use, disclosure, viewing, copying, alteration, dissemination or distribution of, or reliance on, this message is strictly prohibited. If you have received this message in error, or you are not an authorized or intended recipient, please notify the sender immediately by replying to this message, delete this message and all copies from your e-mail system and destroy any printed copies. You are receiving this communication because you are listed as a current WSP contact. Should you have any questions regarding WSP's electronic communications policy, please consult our Anti-Spam Commitment at [www.wsp.com/cas](http://www.wsp.com/cas). For any concern or if you believe you should not be receiving this message, please forward this message to [caslcompliance@wsp.com](mailto:caslcompliance@wsp.com) so that we can promptly address your request. Note that not all messages sent by WSP qualify as commercial electronic messages.

AVIS : Ce message, incluant tout fichier l'accompagnant (« le message »), peut contenir des renseignements ou de l'information privilégiés, confidentiels, propriétaires ou à divulgation restreinte en vertu de la loi. Ce message est destiné à l'usage exclusif du/des destinataire(s) voulu(s). Toute utilisation non permise, divulgation, lecture, reproduction, modification, diffusion ou distribution est interdite. Si vous avez reçu ce message par erreur, ou que vous n'êtes pas un destinataire autorisé ou voulu, veuillez en aviser l'expéditeur immédiatement et détruire le message et toute copie électronique ou imprimée. Vous recevez cette communication car vous faites partie des contacts de WSP. Si vous avez des questions concernant la politique de communications électroniques de WSP, veuillez consulter notre Engagement anti-pourriel au [www.wsp.com/lcap](http://www.wsp.com/lcap). Pour toute question ou si vous croyez que vous ne devriez pas recevoir ce message, prière de le transférer au [conformitelcap@wsp.com](mailto:conformitelcap@wsp.com) afin que nous puissions rapidement traiter votre demande. Notez que ce ne sont pas tous les messages transmis par WSP qui constituent des messages électroniques commerciaux.

-LAEHhHdzJzBITWfa4Hgs7pbKl

This e-mail originates from the City of Ottawa e-mail system. Any distribution, use or copying of this e-mail or the information it contains by other than the intended recipient(s) is unauthorized. Thank you.

Le présent courriel a été expédié par le système de courriels de la Ville d'Ottawa. Toute distribution, utilisation ou reproduction du courriel ou des renseignements qui s'y trouvent par une personne autre que son destinataire prévu est interdite. Je vous remercie de votre collaboration.

## McCaughey, Stephen

---

**From:** Elsayed, Ahmed <ahmed.elsayed@ottawa.ca>  
**Sent:** Tuesday, March 16, 2021 12:25 PM  
**To:** McCaughey, Stephen  
**Cc:** McCreight, Laurel  
**Subject:** RE: 100 Bayshore Drive - Inquiries for Site Plan Application  
**Attachments:** 100 Bayshore March 2021.pdf

Hi Stephen,

Hereunder are the BC as received from IPU.

The following are boundary conditions, HGL, for hydraulic analysis at 100 Bayshore (zone 1W) assumed to be connected to the 203 mm on Bayshore Ave (see attached PDF for location).

Minimum HGL = 106.3 m

Maximum HGL = 115.2 m

Max Day + Fire Flow (133 L/s) = 82.5 m

These are for current conditions and are based on computer model simulation.

*Disclaimer: The boundary condition information is based on current operation of the city water distribution system. The computer model simulation is based on the best information available at the time. The operation of the water distribution system can change on a regular basis, resulting in a variation in boundary conditions. The physical properties of watermains deteriorate over time, as such must be assumed in the absence of actual field test data. The variation in physical watermain properties can therefore alter the results of the computer model simulation.*

Please let me know if you have any questions.

Ahmed

---

**From:** McCaughey, Stephen <Stephen.Mccaughey@wsp.com>  
**Sent:** Monday, March 15, 2021 9:38 AM  
**To:** Elsayed, Ahmed <ahmed.elsayed@ottawa.ca>  
**Cc:** McCreight, Laurel <Laurel.McCreight@ottawa.ca>  
**Subject:** FW: 100 Bayshore Drive - Inquiries for Site Plan Application

**CAUTION: This email originated from an External Sender. Please do not click links or open attachments unless you recognize the source.**

**ATTENTION : Ce courriel provient d'un expéditeur externe. Ne cliquez sur aucun lien et n'ouvrez pas de pièce jointe, excepté si vous connaissez l'expéditeur.**

Hi Ahmed,

Just touching base from my inquiry last Monday, are there any questions or further information you need for water boundary conditions and sanitary capacity?

Thank you,

# Boundary Condition for 100 Bayshore

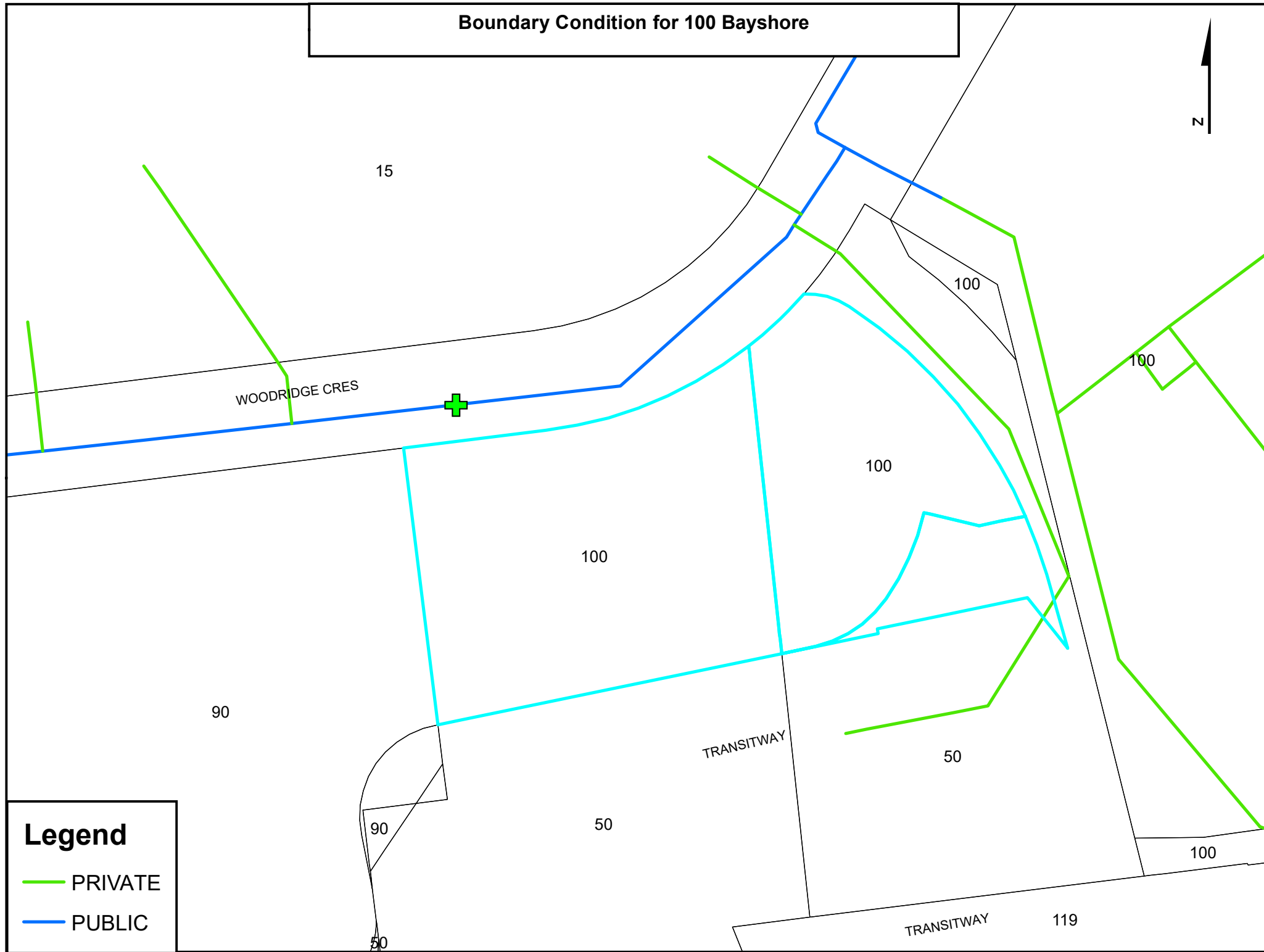

## Legend

-  PRIVATE
-  PUBLIC