

**SITE SERVICING
& STORM WATER MANAGEMENT REPORT
FOR
1050 KLONDIKE ROAD, OTTAWA, ONTARIO**

June 27, 2022

Prepared by:



Jain Infrastructure Consultants Ltd.
7405 East Danbro Crescent, 2nd Floor
Mississauga, Ontario
L5N 6P8 , Canada
Tel: (905) 285-9900
Fax: (905) 567-5246

Report Reference :20-525/FSR Rev 3

TABLE OF CONTENTS

1.	Introduction	4
1.1	Site Description and Proposed Development.....	4
1.1.1	Statement of Objectives and Servicing Criteria	4
1.1.2	Location Map and Plan	4
1.2	Background Documents	4
1.3	Consultation and Permits	5
1.3.1	Pre-consultation Meetings.....	5
1.4	Available Existing Infrastructure	6
2.	Geotechnical Study	6
3.	Water Services	7
3.1	Design Criteria	7
3.2	Water Demand	7
3.3	Adequacy of Supply for Domestic and Fire Flows	8
3.4	Pressure Check	9
3.5	Reliability Requirements.....	9
3.6	Watermain Extension on Klondike Road.....	9
3.7	Water Supply Conclusion.....	10
4.	Sanitary Servicing	10
4.1	Background and Existing Infrastructure.....	10
4.2	Proposed Servicing and Calculations	10
4.3	Sanitary Sewer Extension on Klondike Road	11
4.4	Effect of Proposed Development on Downstream Sanitary Infrastructure	11
4.5	Summary and Conclusions.....	11
5.	Storm Servicing and Stormwater Management.....	11
5.1	Background	11
5.2	Storm Servicing Strategy	11
5.3	Proposed Storm Servicing.....	11
5.4	Design Criteria (Minor and Major Systems).....	12
5.5	Stormwater Quantity Control.....	12
5.5.1	Catchment Areas	12
5.5.2	Peak Flows	12
5.5.3	Allowable Flow/Vortex Control.....	13
5.5.4	Onsite Storage	13
5.5.5	Summary	14
5.5.6	Impact on Existing Stormwater Infrastructure	14
5.6	Storm Water Quality Control.....	14
5.7	Pre-Consultation with MECP and Conservation Authority	14
5.8	Minor and Major Systems	14
5.9	Impacts to Receiving Watercourses	15
5.10	100 Year Flood Levels and Major Flow Routing.....	15
6.	Grading.....	15
7.	Erosion and Sediment Control	15

LIST OF APPENDICES

Appendix A- Site Servicing, Grading and Erosion and Sediment Control, Catchments Plans

Appendix B- Correspondence with Regulatory Authorities

Appendix C- Water Demand, FUS Calculations, Fire Hydrant Coverage Map & Hydraulic Analysis Report

Appendix D- Sanitary Flow Calculations and Drainage Area Plans

Appendix E- Storm Sewer Design Calculations

Appendix F- Site Servicing Checklist

Appendix G- Topographic and Legal Survey

1. Introduction

1.1 Site Description and Proposed Development

This report describes the site servicing and stormwater management design pertaining to a street townhouses development proposed at 1050 Klondike Road. The proposed development consists of 9 townhouse units and parking area. The expected population is considered as 24 persons. The project is submitted for zoning bye law amendment and site plan approval on behalf of IAQI Holdings Inc.

The site contains an existing dwelling with gravel and landscaped areas.



Figure 1 - Site Location Plan

Proposed grading and servicing is shown on the drawings included in **Appendix A**.

1.1.1 Statement of Objectives and Servicing Criteria

The objective of this Site Servicing and Stormwater Management Report is to demonstrate that the proposed design meets the servicing requirements for the proposed development, while adhering to the appropriate regulatory requirements.

1.1.2 Location Map and Plan

The location of the site is illustrated in Figure 1. A detailed site layout is provided within the drawings in Appendix A

1.2 Background Documents

Existing conditions are shown on the Topographic and Legal Survey (Appendix G).

1.3 Consultation and Permits

1.3.1 Pre-consultation Meetings

A pre-consultation meeting was held with the City of Ottawa in May 2020. The comments were received for a condominium building which was later changed to street townhouses. Most of the comments are still relevant to the new proposal and are summarized as follows,

Stormwater Management:

- There is an available 675mm diameter concrete storm sewer located on Sandhill Road conveying flow to a ditch upstream of “Pond C”.
- Based on both the Shirley’s Brook Floodplain Analysis and SWM Report (Klondike Road Development Lands, prepared by Novatech, May 2006) and the Shirley’s Brook SWM Facility “C” Detailed Design Report (prepared by Novatech, 2006), it appears that Pond “C” was sized to service the 1050 Klondike Road parcel. Please demonstrate that the existing storm sewer and pond have capacity to service this proposed development (quantity and quality control).
- Refer to the SWM design criteria in the Shirley’s Brook SWM Facility “C” Detailed Design Report (prepared by Novatech, 2006) for the proposed development area:
 - Minor system allowable release rate of 85 L/s/ha;
 - Onsite major system storage of 50 m³/ha (please see the note below);
 - ICDs [are] installed in the roadway catch basins to ensure flow into the storm sewer system does not exceed the 5-year runoff rates; and
 - HGL for 100-year event must have at least 0.3 m freeboard to the underside of footings.
- IDF information derived from the Meteorological Services of Canada rainfall data, taken from the MacDonald Cartier Airport, collected 1966 to 1997.
- The pre-development runoff coefficient or a maximum equivalent ‘C’ of 0.5, whichever is less (§ 8.3.7.3).
- A calculated time of concentration (Cannot be less than 10 minutes).

Watermain:

- There is an available 300mm diameter PVC watermain fronting the site along Sandhill Road. However, looping of the Klondike Road watermain (from March Road stub to the Sandhill Road stub) is preferred.
- If a watermain extension along Klondike Road is pursued an MECP Form 1 will need to be completed.
- Drinking Water Boundary condition requests must include the location of the service connection and the expected loads required by the proposed development.
- Determine the total water demand based on maximum demand and required fire flow for water boundary conditions.

Sanitary:

- There is an available 200mm diameter PVC sanitary sewer located on Klondike Road. However, it currently does not front the proposed site.
- A sanitary sewer extension within the Klondike Road Right-Of-Way (ROW) will be required to service this site.

- The proponent will be required to demonstrate what the expected sanitary flows from the proposed site will be and show that the existing sanitary sewer infrastructure can accommodate the proposed site flows without any adverse affects.
- The existing sanitary sewer on Klondike Road connects to the Briar Ridge Pump Station (BRPS). This pump station currently has limited capacity. Upgrades to the BRPS are expected to be completed by Dec 2021 or early 2022.
- Due to the municipal sanitary sewer extension a Ministry of Environment, Conservation and Parks Environmental Compliance Approval (MECP ECA) will be required and will be reviewed under the Transfer of Review program (Standard Works) with the City of Ottawa.
- Also due to the municipal sanitary extension, a Municipal Consent (MC) circulation will be required after or in the later stages of the Site Plan Application stage. The ROW Approvals Department at the City, may, to their review and discretion, exempt the proposed extension from the MC Circulation process.

The full comments regarding site-servicing and stormwater management-specific requirements can be found in **Appendix B**.

1.4 Available Existing Infrastructure

Sewer and watermain mapping collected from the City of Ottawa indicate that the following services exist across the property frontages and the Sandhill Road intersection.

Sandhill Road

- 300mm diameter PVC watermain
- 675mm diameter Conc. storm sewer

The existing development is not served by municipal services. An existing well and septic system is currently working on site which will be decommissioned as per city/ MOE requirements.

A demolition plan is prepared to show the removal of existing features on site prior to construction. (Refer drawing C105)

2. Geotechnical Study

A Geotechnical Investigation was completed by GEMTEC and is documented in Report No. 65153.01 dated April 7, 2020.

A total of 3 boreholes were drilled to a maximum depth of 6.7 - 8.5m below the existing ground surface. The subsurface profile at the borehole locations consists of 100mm topsoil layer underlain by a fill layer to approximately 1.2 to 2.9m depth.

The fill material below the topsoil and/or granular fill material can be described as brown, fine to coarse grained sand with trace to some silt. The fill material extends to depths ranging from about 1.2 to 2.9 meters below existing grade (elevation 73.5 to 76.1 meters)

Groundwater was encountered at depths of 3.8 to 5.3m below the existing ground surface.

The geotechnical report provides recommendations for excavation, backfill, pavement structure and pipe bedding and backfill.

3. Water Services

3.1 Design Criteria

The water service will be designed in accordance with the 2010 City of Ottawa Water Design Guidelines as well as MOE Design Guidelines for Drinking Water Systems.

The required domestic water demand and pressure design parameters for the development has been calculated based in **Table 1**:

Table 1– Summary of Water Demand Parameters

Design Parameter	Value
	Residential
Average Daily Demand	350 L/d/P ¹
Max. Daily Peaking Factor	9.5 x Average Daily ²
Max. Hourly Peaking Factor	14.3 x Average Daily ²
Minimum Watermain Size	150mm diameter
Minimum Depth of Cover	2.4m from top of watermain to finished grade
Min. pressure during normal operating conditions	345kPa
Max. pressure during normal operating conditions	552kPa
Min. pressure during maximum hourly demand	276kPa
Min. pressure during maximum daily demand + fire flow	140kPa
¹ Daily average based on Appendix 4-A from Water Supply Guidelines ² Residential Max. Daily and Max. Hourly peaking factors per MOE Guidelines for Drinking-Water Systems Table 3-3 for 0 to 500 person	

3.2 Water Demand

Total No. Townhouse Units = 9 units (7 Units are 3-Storeys, 2 Units are 2-Storeys stacked dwelling)

Gross Floor Area = 1511 m² (Approximate area of each floor = 503 m²)

Population = 2.7 x 9 = 24 persons

Daily Average Water Demand = 24 x 350 l/cap/day = 84,00 L/Day = 0.097 L/sec

Maximum Daily Demand = 0.097 x 9.5 = 0.92 L/sec

Maximum Hourly Demand = 0.097 x 14.3 = 1.39 L/sec

The water demand/fire flow for the development based on the **Ottawa Design Guidelines (2010 incl. Technical Bulletins)** and the **Fire Underwriters Survey (1999)** is summarized below;

Table 2– Summary of Water Demand Calculations

Design Parameter	Water Demand (L/s)
	Residential
Average Daily Demand	0.097
Maximum Daily Demand	0.92
Maximum Hourly Demand	1.39
Fire Flow	216.67
Total Max Daily Demand + Fire Flow	217.59

Fire flow calculations, Fire hydrant coverage map (DR03) are provided in Appendix C.

Total no. of 9 water service connections (19 mm diameter, approximate length 15m-18m) are provided for each unit. The service connections will be installed by 1055 Klondike contractor from 400 mm diameter water main along Klondike Road. Refer Drawing C101 for details.

3.3 Adequacy of Supply for Domestic and Fire Flows

Preliminary water demands and fire flow requirements for the proposed development were provided to the City of Ottawa (Table 2). The City of Ottawa was contacted to obtain boundary conditions associated with the estimated water demand, as indicated in the boundary request correspondence included in Appendix C.

The City provided both the anticipated minimum and maximum water pressures, as well as, the estimated water pressure during fire flow, as indicated by the correspondence and results of boundary conditions (Appendix C).

Fire flow calculated using the ISTDB-2018-02 method used the following assumptions from the Architect:

- Type of construction – Combustible;
- Occupancy type – Limited Combustibility;
- Sprinkler Protection – None; and
- Single block considered for the townhouses block.

The above assumptions result in a maximum estimated fire flow of approximately 13,000 L/min (217 l/sec). See Appendix C for detailed calculations using the ISDTB-2018-02 method. The minimum and maximum pressures fall within the required range identified in Table 3.1 & 3.2 below. Two connection nodes have been analyzed at March Road (Node 1) and at Sandhill Road (Node 2).

Table 3.1 - Results from Hydraulic Analysis – Connection 1

Demand Scenario	Head (m)	Pressure (psi)
Maximum HGL	130.5	76.8
Peak Hour	126.1	70.5
Max Day plus Fire 1 (at 167 l/sec)	123.3	66.5
Max Day plus Fire 2 (at 250 l/sec)	120.1	62.0

Ground Elevation = 76.5 m

Table 3.2 - Results from Hydraulic Analysis – Connection 2

Demand Scenario	Head (m)	Pressure (psi)
Maximum HGL	130.5	79.1
Peak Hour	126.2	72.8
Max Day plus Fire 1 (at 167 l/sec)	122.5	67.7
Max Day plus Fire 2 (at 250 l/sec)	118.5	61.9

Ground Elevation = 74.9 m

Hydraulic Analysis of the watermain network was carried out by Novatech (Refer Novatech Memorandum dated June 14, 2022, Appendix C). It was concluded that fire hydrants available within the 75m radius from the proposed development are shown on Drawing DR03, Appendix C. Two fire hydrants are rated AA (blue top) as per correspondence with the city (Refer Appendix C). This means that 5700 l/min (95 l/sec) flow will be available from each hydrant, thus providing a total flow of 11,440 l/min within the 75m radius. An additional hydrant (HYD4) has been proposed by Novatech on Klondike Road as part of their development which is within the 75m radius and provide a maximum flow of 5700 l/min (95 l/sec). Therefore, the required fire flow demand will be met by the two existing and one new hydrant. Water retention was analyzed at each node during average day demand in the Novatech Hydraulic analysis. The maximum age throughout the system is within City standards.

3.4 Pressure Check

As per Novatech Hydraulic Analysis results summary (Refer Appendix C), the maximum pressure of 552.70 kPa is available at existing hydrant 1 and 514.83 kPa at proposed hydrant 4 (HYD4). The average day pressure at existing hydrant 1 (EXHYD1) is slightly above 552 kPa. The remaining average day pressures which are in closer proximity to the water service connections are below 552 kPa, therefore pressure reducing valves are not required.

3.5 Reliability Requirements

A shut off valve for the water service will be provided at the property line.

3.6 Watermain Extension on Klondike Road

In order to service the townhouse block for water, multiple options were discussed with the city staff which consisted of servicing through the laneway as private services or from Klondike Road as municipal services. The servicing option from Klondike Road was preferred and adopted for the project.

The watermain extension on Klondike Road is part of proposed servicing for 1055 Klondike Road development. Water Services drops for the current project will also be provided by the 1055 Klondike Road contractor. Coordination with Novatech was done to obtain the watermain extension design and is shown on the site plan as “work done by others”. The final sequence of construction and cost sharing is being discussed and will be submitted to the city.

The watermain extension on Klondike Road and servicing for the townhouses is shown on Drawing C101, Appendix A.

3.7 Water Supply Conclusion

It is proposed to service the private development from the proposed watermain extension on Klondike Road. Individual service connections are proposed from the 400mm watermain which will be installed as part of 1055 Klondike Road development works.

The anticipated water demand was submitted to the City of Ottawa for establishing boundary conditions. The City provided both the anticipated minimum and maximum water pressures, as well as, the estimated water pressure during fire flow. As demonstrated by Table 2 & 3, based on the City’s model, the municipal system is capable of delivering water within the pressure range prescribed in the Water Supply Guidelines.

Hydraulic Analysis carried out by Novatech concludes that the required fire and domestic flow can be met with the two existing hydrants and one proposed hydrant on Klondike Road.

The available pressure during the fire flow scenario as per the OBC and ISDTB-2018-02 calculations exceeds 140 kPa. The proposed water supply design conforms to all relevant City Guidelines and Policies.

4. Sanitary Servicing

4.1 Background and Existing Infrastructure

Sanitary sewer along the property frontage on Klondike Road is not available. The sanitary extension will be installed as part of 1055 Klondike Road development works along with sanitary drops from the 1050 Klondike Road development.

4.2 Proposed Servicing and Calculations

The proposed development will require individual service connections to the townhouses from the proposed sanitary sewer extension on Klondike Road which will be provided by the 1055 Klondike Road contractor.

The sanitary servicing design parameters are defined in Table 4.

Table 4 - Summarization of Sanitary Servicing Design Parameters

Design Parameter	Value
Residential Average Flow	280 l/c.d
Residential Peaking Factor (Maximum 4.0)	Based on the Harmon Equation $P.F. = 1 + \left(\frac{14}{4 + \left(\frac{P}{1000} \right)^{\frac{1}{2}}} \right) * K$
Infiltration and Inflow Allowance	0.33 L/ha/s
Design Parameter	Value
Manning’s Coefficient ‘n’	0.013
Minimum Depth of Cover	2.5m from obvert of sewer to grade
Minimum Full Flowing Velocity	0.6m/s
Maximum Full Flowing Velocity	3.0m/s
As per Sections 4 and 6 of the City of Ottawa Sewer Design Guidelines, October 2012 incl. all Tech. Bulletins as of November 2019	

Total No. of Townhouse Units = 9 units

Population = $2.7 \times 9 = 24$ persons

Average Daily Flow = $24 \times 280 \text{ l/c/d} = 6,720 \text{ l/day} = 0.078 \text{ l/sec}$

Catchment Area = 0.16 ha (Refer sanitary drainage plan DR04 attached in Appendix D)

Infiltration Allowance = $0.16 \times 0.33 \text{ l/day} = 0.053 \text{ l/sec}$

Harmon's Peaking Factor = 4.0

Peak Flow = $0.078 \times 4.0 + 0.053 = 0.365 \text{ l/sec}$.

Total no. of 9 sanitary service connections (125 mm diameter, approximate length 10m-14m) are proposed to be connected to the sanitary sewer extension with built in tees on Klondike Road. The service stubs will be provided by the 1055 Klondike Road contractor. The arrangement of service connections is shown on Drawing C101.

4.3 Sanitary Sewer Extension on Klondike Road

As per pre consultation comments, extension of sanitary sewer on Klondike Road is required to service the site. Sanitary sewer extension is shown on Drawing C101 which is based on the design proposed by Novatech for 1055 Klondike Road development. Sanitary Sewer sizing calculations are attached in **Appendix D**.

4.4 Effect of Proposed Development on Downstream Sanitary Infrastructure

The proposed development at present is not part of the contributing area for Briar Ridge Pump station (Refer sanitary drainage plan of Briar Ridge Pump station attached in Appendix D). However, sanitary sewer extension along with proposed service drops on Klondike Road will add the site to the contributing area of Briar Ridge Pump station. As per sanitary flow calculations, an additional flow of 0.36 l/sec is added to the sanitary sewer on Klondike Road. The additional flow gets reduced to 0.3 l/sec downstream due to the peak factor calculations at higher population counts. The pre and post development sanitary flows are shown in Appendix D.

4.5 Summary and Conclusions

The proposed development requires extension of sanitary sewer west of Sandhill street intersection that to be completed by 1055 Klondike Road contractor. An additional flow of 0.3 l/sec is added to the existing sanitary infrastructure which is considered a small addition that will not compromise the sanitary sewer/ pump station capacity or result in significant change to the sanitary hydraulic grade line.

5. Storm Servicing and Stormwater Management

5.1 Background

The existing site does not have a piped storm connection. The site sheet drains towards existing ditch inlet catch basin at Klondike Road and Sandhill Road intersection without any storm water management controls.

5.2 Storm Servicing Strategy

The proposed stormwater management system will provide the necessary detention storage on site to meet the stormwater management requirements. Quantity control will be provided to control the post development flows to the stipulated subdivision criteria of 85 l/sec/ha.

5.3 Proposed Storm Servicing

A new 300 mm diameter storm service will extend from the east side of the proposed development to connect to the existing 675mm storm sewer on Sandhill Road. The proposed pre-development and post-

development catchment areas, runoff coefficients and catchment total areas are indicated in **Appendix E**.

5.4 Design Criteria (Minor and Major Systems)

The site specific SWM criteria as per the comments from the city’s pre consultation meeting are as follows,

- Refer to the SWM design criteria in the Shirley’s Brook SWM Facility “C” Detailed Design Report (prepared by Novatech, 2006) for the proposed development area:
 - Minor system allowable release rate of 85 L/s/ha;
 - Onsite major system storage of 50 m³/ha
- Rational method is used to calculate pre and post development flows

Rational Method (Q) = 2.78CIA, where

Q = peak flow (L/s)

C = runoff coefficient

I = rainfall intensity

Intensity is calculated by the following formulae,

$$i = \frac{A}{(T_d + C)^B}$$

where A, B and C are all factors of the IDF Return Period, T_d being the time of concentration and A the drainage area (Detailed calculations provided in **Appendix E**).

Time of concentration is determined using the inlet time graph (Appendix 5D Ottawa City Sewer Design Guidelines) which results in a value less than 10 minutes. Therefore 10 minutes will be used to calculate peak flows.

5.5 Stormwater Quantity Control

5.5.1 Catchment Areas

The site is mainly divided in to two catchments based on proposed development and grading. Catchment Area (A1 - 0.126 ha) consists of building footprint and parking area. Area A1 will be controlled and outlet to existing storm network on Sandhill Road.

Catchment Area (A2 - 0.031ha) consist of mostly landscape area with partially hardscape surface. Area A2 is uncontrolled and discharged towards existing ditch inlet catch basin at Sandhill Road and Klondike Road intersection in pre and post development conditions.

In predevelopment conditions, the whole site area runoff is flowing uncontrolled. After development about 80% of site area run off will be controlled.

Pre and post development drainage area plans are attached as DR01 and DR02 in Appendix A.

5.5.2 Peak Flows

Table E1 attached in Appendix E shows the overall pre development site runoff coefficient as 0.50 which is in line with the pre consultation comments limiting the pre development runoff coefficient to 0.5 or less. As per sanitary catchment plan of Pond C storm sewers, the site is included in the catchment Area 59 (Refer Brookside Sub division Storm Drainage Plan attached in Appendix E) at a runoff coefficient of 0.45. Further a minor system flow rate of 85 l/sec /ha is recommended as per pre

consultation comments. The allowable flow as per these limiting criteria are presented in Table 5 below to demonstrate that the site has been over controlled to the most stringent case.

Table 5– Allowable Flow and Storage Summary

Return Period (yrs)	Catchment Area* (ha)	Uncontrolled Pre Development Flow @ R=0.45 (liters/sec)	Uncontrolled Post Development Flow @ (liters/sec)	Controlled Post Development Flow @ 85 l/sec/ha (liters/sec)	Storage Required (m ³)
2	0.126	12.06	21.23	10.71	6.31
5	0.126	16.36	28.80	10.71	11.15
10	0.126	19.18	33.76	10.71	14.70
25	0.126	22.72	39.99	10.71	19.41
50	0.126	25.35	44.63	10.71	23.13
100	0.126	35.00	61.61	10.71	37.82**

*-Site Area A1 (0.126ha) is the controlled area. Area A2 (0.031ha) is uncontrolled area due to grading constraints and is deducted from pre and post development flow calculations.

** Maximum storage required.

5.5.3 Allowable Flow/Vortex Control

As per subdivision criteria, the site will be controlled to 85 l/sec/ha which provides an allowable release rate of 10.71 l/sec. A Vortex Flow Control Valve (Hydro-Break) is proposed to control the post development flow to 10.71 l/sec (Refer Appendix E for details).

5.5.4 Onsite Storage

An allowable flow of 10.71 l/sec has been used for storage calculations using Rational formula. The calculation of required onsite storage volume is given in Table E4, E5 and E6, Appendix E.

The required onsite storage is summarized for all storms (Refer Table 5 above). The maximum onsite storage volume of 37.82 m³ is required to control 100 year post development flows. Ponding on surface will not occur for all storms (2-100 year) scenario as required storage is available in the below ground storm tank.

5.5.4.1 Storm Tank

Brentwood Storm Tank (ST-24) is provided to meet the onsite storage requirement. The tank has total capacity of 38.83 m³. The Storm tank model volume calculator sheet and specifications are provided in Appendix E.

(Refer drawing C101 for storm tank details and location)

5.5.5 Summary

Table 6 summarizes the proposed release rates and confirms that the total release rate does not exceed the allowable release rate.

Table 6 – Post-Development Controlled Peak Flows

	Post-Development Controlled Peak Flows (L/s)
Allowable Release Rate @ 85 l/s/ha (l/sec)	10.71
Release Rate from Controlled Drainage Areas (l/sec)	10.71
Required Storage (m ³)	37.82
Provided Storage (m ³)	38.83

Therefore, a total of **38.83 m³** of onsite detention is available compared to the required storage of 37.82 m³. Ponding will not occur for all storms (2-100 year) scenario as required storage is available below ground in storm tank.

5.5.6 Impact on Existing Stormwater Infrastructure

The proposed development was included as Catchment Area 59 (Refer Brookside Subdivision Storm Drainage Plan in Appendix E). The plan shows that the site was accounted as a catchment area with runoff coefficient of 0.45 which allows a 5year flow of 17.0 l/sec. As described in section 5.5.1, the onsite quantity controls limit the site discharge to 10.71 l/sec to ensure that the downstream storm sewers and storm water pond “C” capacity and hydraulic grade line is not affected by the proposed development.

Storm Sewer Design Calculations are provided in **Appendix E**.

5.6 Storm Water Quality Control

The required water quality treatment is achieved with the help of a treatment train approach comprising of the following measures,

- 1- MVCA considers run-off from building roof areas to be “clean”, and therefore not require quality control.
- 2- Oil/grit separator (OGS) has been proposed as Stormceptor EFO4 unit shown on Drawing C101, Appendix A. The sizing calculations are attached in Appendix E which shows that the unit is capable of achieving 90% TSS removal for site flows.

5.7 Pre-Consultation with MECP and Conservation Authority

As the sanitary sewer extension is designed and constructed under 1055 Klondike Road development works, therefore MECP approval will also be covered under the approval process for 1055 Klondike Road, being designed by Novatech.

5.8 Minor and Major Systems

The minor storm sewer system consists of the storm connection from the townhouse block up to the city storm sewer on Sandhill Road. The major system consists of flow east through the laneway on to Sandhill Road. The site has been graded to direct run-off from storms in excess of the 100-year event safely to Sandhill Road.

Individual townhouse roof areas will discharge at surface on the laneway as shown on Drawing C101, Appendix A.

5.9 Impacts to Receiving Watercourses

No negative impacts to receiving watercourses are anticipated.

5.10 100 Year Flood Levels and Major Flow Routing

The site is not within a 100-year floodplain.

6. Grading

The proposed grading plan is shown in Drawing C102 in **Appendix A**. The development will be tied into existing grades along Sandhill Road and Klondike Road.

The existing grades will be matched at the property limits along the south and west property boundary.

7. Erosion and Sediment Control

During all construction activities, erosion and sedimentation shall be controlled by the following techniques:

- Extent of exposed soils shall be limited at any given time;
- Exposed areas shall be re-vegetated as soon as possible;
- Minimize the area to be cleared and disruption of adjacent areas;
- Silt sack or approved equivalent shall be installed inside all catch basins, catch basin manholes, and storm manholes as identified on the erosion and sediment control plan;
- Mud matt is required at the construction entrance to prevent mud tracking on municipal roads. Mud matt to be installed and maintained as indicated on the erosion and sediment control plan;
- Visual inspection shall be completed daily on sediment control barriers and any damage repaired immediately. Care will be taken to prevent damage during construction operations;
- In some cases, barriers may be removed temporarily to accommodate the construction operations. The affected barriers will be reinstated at night when construction is completed;
- Sediment control devices will be cleaned of accumulated silt as required. The deposits will be disposed of as per the requirements of the contract;
- During construction, if the engineer believes that additional prevention methods are required to control erosion and sedimentation, the contractor will install additional silt fences or other methods as required to the satisfaction of the engineer; and,
- Construction and maintenance requirements for erosion and sediment controls are to comply with Ontario Provincial Standard Specification (OPSS) 805.

We trust you will find this submission complete and in order. Should you have any questions, please contact the undersigned.

Respectfully Submitted,
Jain Infrastructure Consultants Ltd.

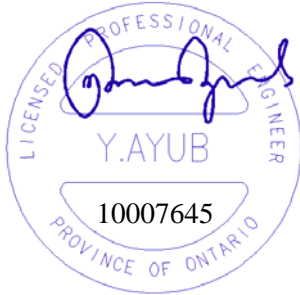

Yasar Ayub , P.Eng
Project Engineer
June 27, 2022

Usman Arif
Project Designer
June 27, 2022

Appendix A

Figures

DR01 Pre Development Drainage Areas

DR02 Post Development Drainage Areas

Site Servicing, Grading and Erosion and Sediment Control Plan

Removal & Demolition Plan

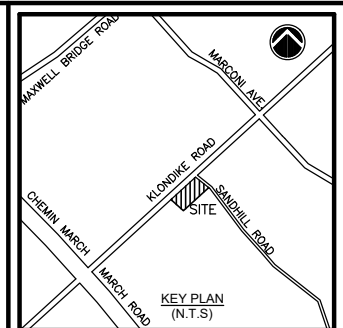

LEGAL DESCRIPTION:
 PLAN OF SURVEY & TOPOGRAPHIC INFORMATION PREPARED BY ANNIS, O'SULLIVAN, VOLLEBEKK LTD. (O.L.S.), IDENTIFIED AS PART OF LOT 10, CONCESSION 4 GEOGRAPHIC TOWNSHIP OF MARCH CITY OF OTTAWA

BEARING NOTE:
 BEARINGS ARE GRID, DERIVED FROM CAN-NET 2016 REL. TIME NETWORK GPS OBSERVATIONS, MTM ZONE 9 (76° 30' WEST LONGITUDE) NAD-83 (ORIGINAL).

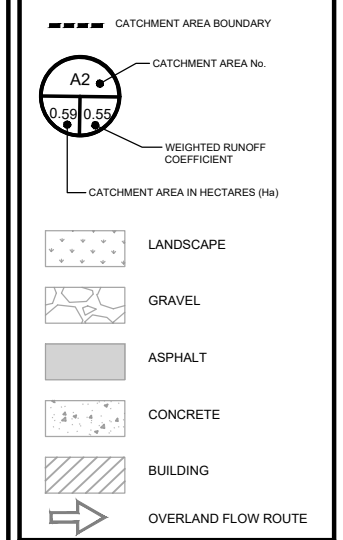

REVISION		
No.	DESCRIPTION	DATE
2	ISSUED FOR SPA	JUN 27, 22
1	ISSUED FOR SPA	NOV 25, 21

JAIN
 Jain Infrastructure Consultants Ltd.
 7405 EAST DANBRO CRESCENT
 MISSISSAUGA, ON L5N 6P8
 TEL: (905) 285-9900, FAX: (905) 567-5246
 Email: yayub@jainconsultants.com

PROJECT
 1050 KLONDIKE ROAD
 OTTAWA, ONTARIO, K2K 1X7

DRAWING TITLE
 PRE DEVELOPMENT DRAINAGE AREAS

SCALE: 1:125
 DATE: Jun. 27, 22
 DRAWN BY: CC
 CHECKED BY: YA
 DWG No. DR01

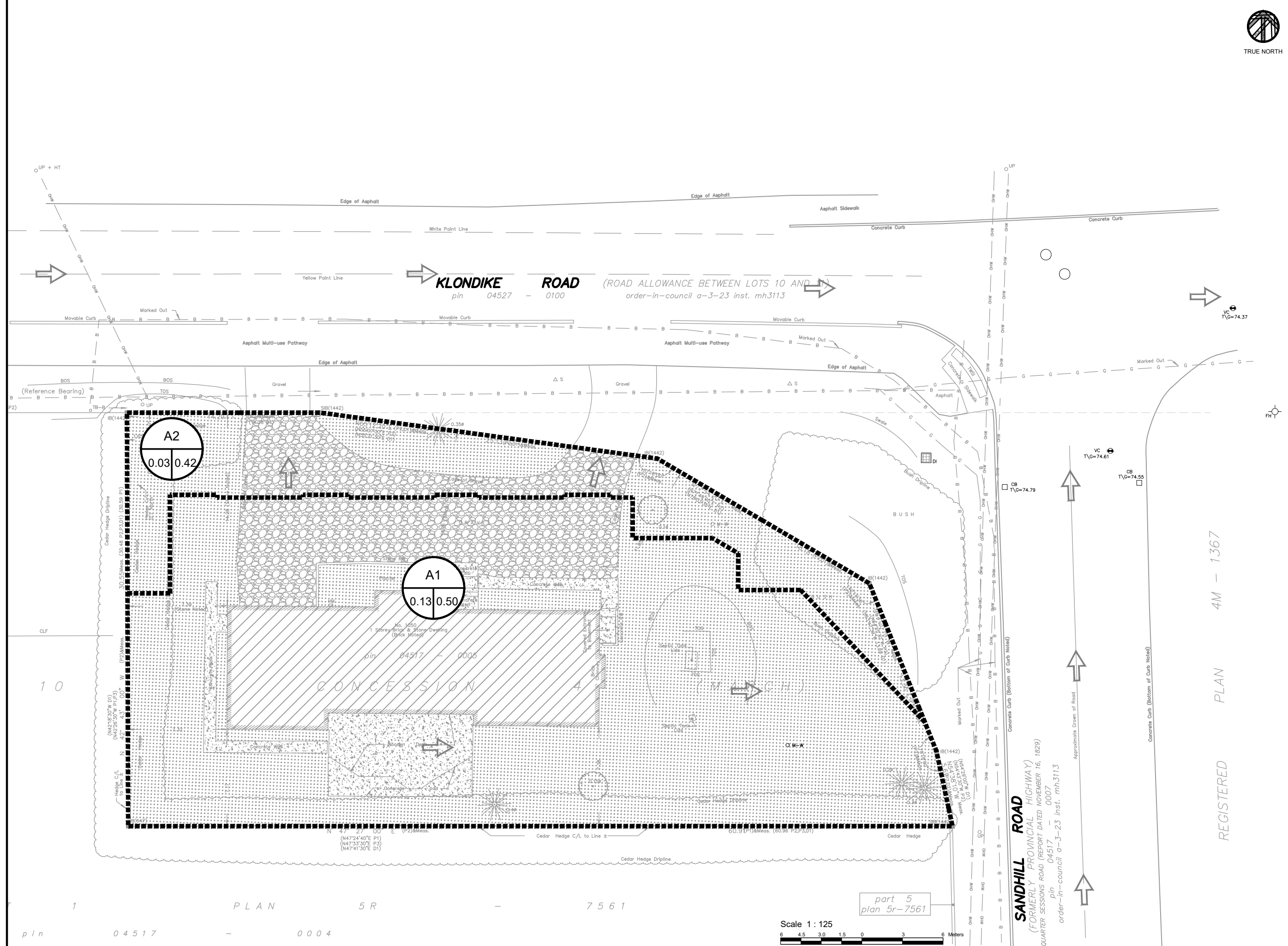

part 5
 plan 5r-7561

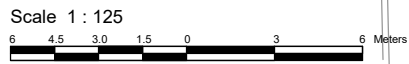

1 PLAN 5R - 7561

pin 04517 - 0004

SANDHILL ROAD
 (FORMERLY PROVINCIAL HIGHWAY)
 QUARTER SESSIONS ROAD (REPORT DATED NOVEMBER 16, 1829)
 pin 04517 0007
 order-in-council a-3-23 inst. mh3113

REGISTERED PLAN 4M - 1367

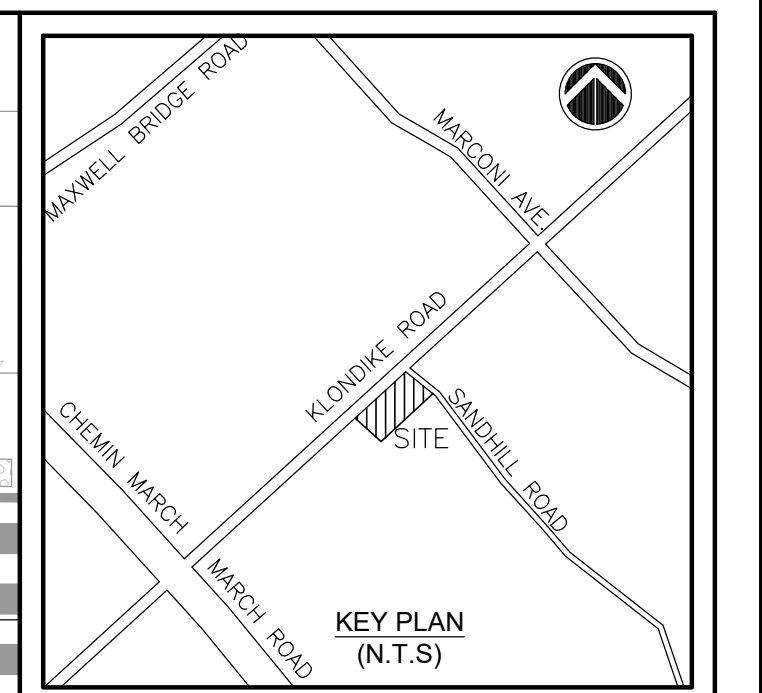
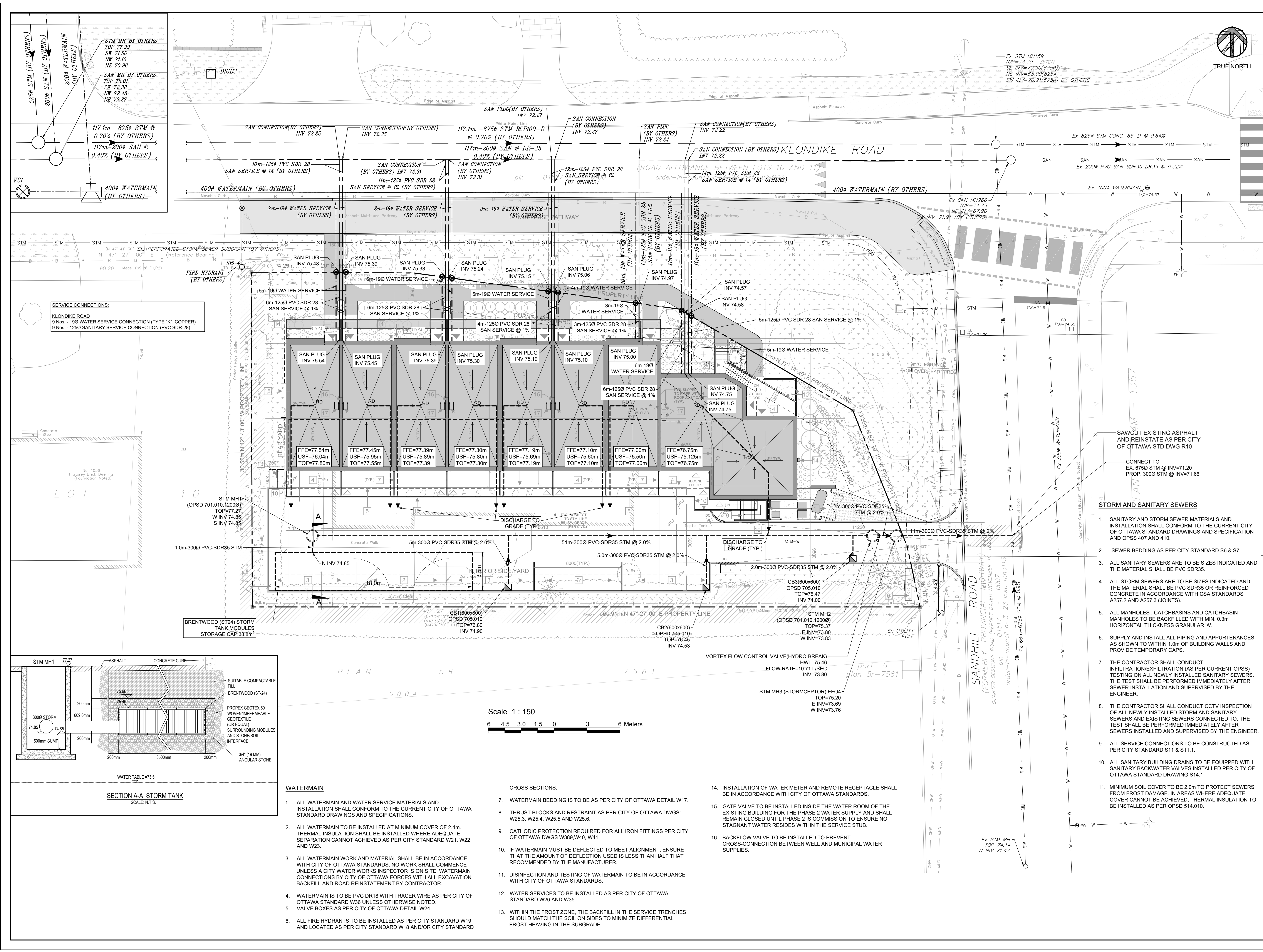

DRAWING REFERENCES
 1. THE SITE PLAN MUST BE READ IN CONJUNCTION WITH ARCHITECTURAL, LANDSCAPING, ELECTRICAL & STRUCTURAL PLANS.
 2. FOR GRADING PLAN, REFER DRAWING C102
 3. FOR EROSION CONTROL, CITY STANDARD NOTES & DETAILS REFER DRAWING C103.

LEGAL DESCRIPTION:
 PLAN OF SURVEY & TOPOGRAPHIC INFORMATION PREPARED BY ANNIS, O'SULLIVAN, VOLLEBEK LTD. (O.S.), IDENTIFIED AS PART OF LOT 10, CONCESSION 4 GEOGRAPHIC TOWNSHIP OF MARCH CITY OF OTTAWA

BEARING NOTE:
 BEARINGS ARE GRID, DERIVED FROM CAN-NET 2016 REL TIME NETWORK GPS OBSERVATIONS, MTM ZONE 9 (76° 30' WEST LONGITUDE) NAD-83 (ORIGINAL).

LEGEND

	PROPOSED STORM MANHOLE
	PROPOSED SANITARY MANHOLE
	PROPOSED CATCH BASIN
	PROPOSED FIRE HYDRANT
	EXISTING MANHOLE
	EXISTING CATCH BASIN
	EXISTING VALVE CHAMBER (WATERMAIN)
	EXISTING FIRE HYDRANT
	EXISTING WATER MAIN
	EXISTING SANITARY
	EXISTING STORM
	CURB STOP
	ROOF DRAIN
	TOF
	USF
	FFE

SAWCUT EXISTING ASPHALT AND REINSTATE AS PER CITY OF OTTAWA STD DWG R10
 CONNECT TO EX. 6750 STM @ INV=71.20
 PROP. 3000 STM @ INV=71.66

STORM AND SANITARY SEWERS

- SANITARY AND STORM SEWER MATERIALS AND INSTALLATION SHALL CONFORM TO THE CURRENT CITY OF OTTAWA STANDARD DRAWINGS AND SPECIFICATION AND OPSS 407 AND 410.
- SEWER BEDDING AS PER CITY STANDARD S6 & S7.
- ALL SANITARY SEWERS ARE TO BE SIZES INDICATED AND THE MATERIAL SHALL BE PVC SDR35.
- ALL STORM SEWERS ARE TO BE SIZES INDICATED AND THE MATERIAL SHALL BE PVC SDR35 OR REINFORCED CONCRETE IN ACCORDANCE WITH CSA STANDARDS A257.2 AND A257.3 (JOINTS).
- ALL MANHOLES, CATCHBASINS AND CATCHBASIN MANHOLES TO BE BACKFILLED WITH MIN. 0.3m HORIZONTAL THICKNESS GRANULAR 'A'.
- SUPPLY AND INSTALL ALL PIPING AND APPURTENANCES AS SHOWN TO WITHIN 1.0m OF BUILDING WALLS AND PROVIDE TEMPORARY CAPS.
- THE CONTRACTOR SHALL CONDUCT INFILTRATION/EXFILTRATION (AS PER CURRENT OPSS) TESTING ON ALL NEWLY INSTALLED SANITARY SEWERS. THE TEST SHALL BE PERFORMED IMMEDIATELY AFTER SEWER INSTALLATION AND SUPERVISED BY THE ENGINEER.
- THE CONTRACTOR SHALL CONDUCT CCTV INSPECTION OF ALL NEWLY INSTALLED STORM AND SANITARY SEWERS AND EXISTING SEWERS CONNECTED TO. THE TEST SHALL BE PERFORMED IMMEDIATELY AFTER SEWERS INSTALLED AND SUPERVISED BY THE ENGINEER.
- ALL SERVICE CONNECTIONS TO BE CONSTRUCTED AS PER CITY STANDARD S11 & S11.1.
- ALL SANITARY BUILDING DRAINS TO BE EQUIPPED WITH SANITARY BACKWATER VALVES INSTALLED PER CITY OF OTTAWA STANDARD DRAWING S14.1
- MINIMUM SOIL COVER TO BE 2.0m TO PROTECT SEWERS FROM FROST DAMAGE. IN AREAS WHERE ADEQUATE COVER CANNOT BE ACHIEVED, THERMAL INSULATION TO BE INSTALLED AS PER OPSD 514.010.

SERVICE CONNECTIONS:
 KLONDIKE ROAD
 9 Nos. - 190 WATER SERVICE CONNECTION (TYPE 'K', COPPER)
 9 Nos. - 1250 SANITARY SERVICE CONNECTION (PVC SDR-28)

1 Storey Brick Dwelling (Foundation Noted)

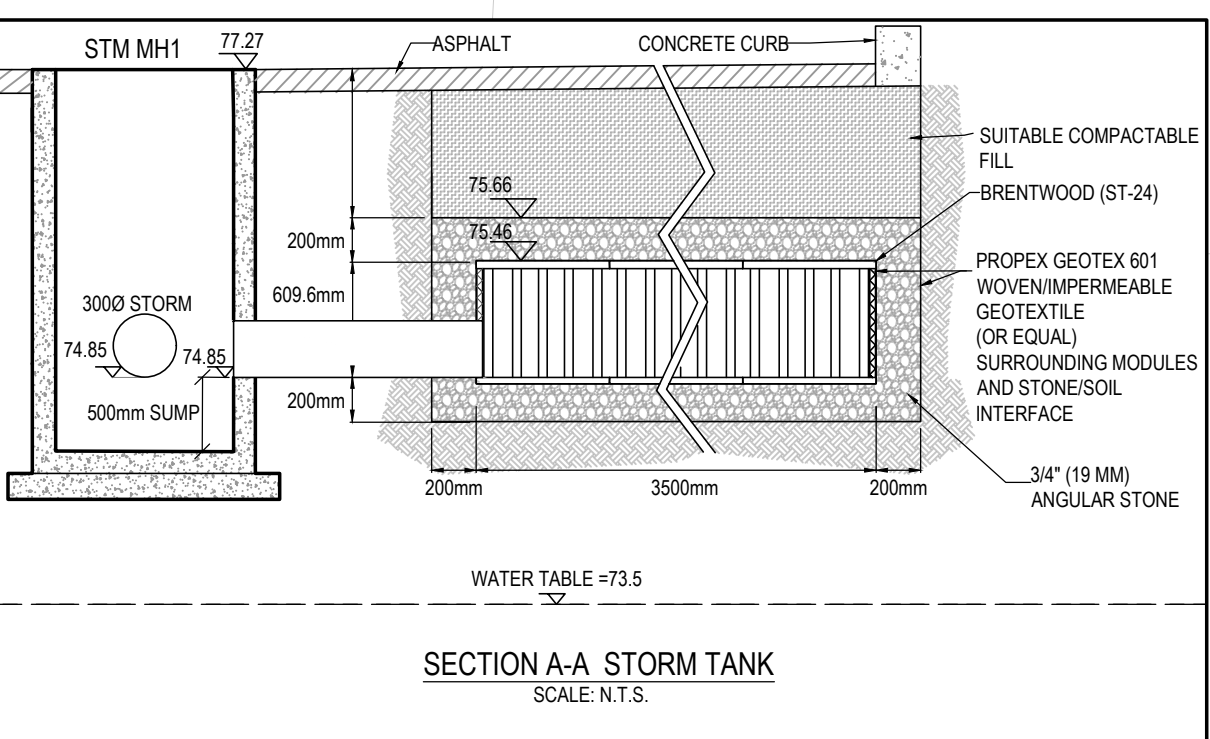

- WATERMAIN**
- ALL WATERMAIN AND WATER SERVICE MATERIALS AND INSTALLATION SHALL CONFORM TO THE CURRENT CITY OF OTTAWA STANDARD DRAWINGS AND SPECIFICATIONS.
 - ALL WATERMAIN TO BE INSTALLED AT MINIMUM COVER OF 2.4m. THERMAL INSULATION SHALL BE INSTALLED WHERE ADEQUATE SEPARATION CANNOT BE ACHIEVED AS PER CITY STANDARD W21, W22 AND W23.
 - ALL WATERMAIN WORK AND MATERIAL SHALL BE IN ACCORDANCE WITH CITY OF OTTAWA STANDARDS. NO WORK SHALL COMMENCE UNLESS A CITY WATER WORKS INSPECTOR IS ON SITE. WATERMAIN CONNECTIONS BY CITY OF OTTAWA FORCES WITH ALL EXCAVATION BACKFILL AND ROAD REINSTATEMENT BY CONTRACTOR.
 - WATERMAIN IS TO BE PVC DR18 WITH TRACER WIRE AS PER CITY OF OTTAWA STANDARD W36 UNLESS OTHERWISE NOTED.
 - VALVE BOXES AS PER CITY OF OTTAWA DETAIL W24.
 - ALL FIRE HYDRANTS TO BE INSTALLED AS PER CITY STANDARD W19 AND LOCATED AS PER CITY STANDARD W18 AND/OR CITY STANDARD

- CROSS SECTIONS.**
- WATERMAIN BEDDING IS TO BE AS PER CITY OF OTTAWA DETAIL W17.
 - THRUST BLOCKS AND RESTRAINT AS PER CITY OF OTTAWA DWGS: W25.3, W25.4, W25.5 AND W25.6.
 - CATHODIC PROTECTION REQUIRED FOR ALL IRON FITTINGS PER CITY OF OTTAWA DWGS W389, W40, W41.
 - IF WATERMAIN MUST BE DEFLECTED TO MEET ALIGNMENT, ENSURE THAT THE AMOUNT OF DEFLECTION USED IS LESS THAN HALF THAT RECOMMENDED BY THE MANUFACTURER.
 - DISINFECTATION AND TESTING OF WATERMAIN TO BE IN ACCORDANCE WITH CITY OF OTTAWA STANDARDS.
 - WATER SERVICES TO BE INSTALLED AS PER CITY OF OTTAWA STANDARD W26 AND W35.
 - WITHIN THE FROST ZONE, THE BACKFILL IN THE SERVICE TRENCHES SHOULD MATCH THE SOIL ON SIDES TO MINIMIZE DIFFERENTIAL FROST HEAVING IN THE SUBGRADE.
 - INSTALLATION OF WATER METER AND REMOTE RECEPTACLE SHALL BE IN ACCORDANCE WITH CITY OF OTTAWA STANDARDS.
 - GATE VALVE TO BE INSTALLED INSIDE THE WATER ROOM OF THE EXISTING BUILDING FOR THE PHASE 2 WATER SUPPLY AND SHALL REMAIN CLOSED UNTIL PHASE 2 IS COMMISSIONED TO ENSURE NO STAGNANT WATER RESIDES WITHIN THE SERVICE STUB.
 - BACKFLOW VALVE TO BE INSTALLED TO PREVENT CROSS-CONNECTION BETWEEN WELL AND MUNICIPAL WATER SUPPLIES.



REVISION		
No.	DESCRIPTION	DATE
3	ISSUED FOR SPA	JUN 27,22
2	ISSUED FOR SPA	NOV 25,21
1	ISSUED FOR SPA	MAY 19,21

JAIN
 Jain Infrastructure Consultants Ltd.
 7405 EAST DANBRO CRESCENT
 MISSISSAUGA, ON L5N 6P8
 TEL: (905) 285-9900, FAX: (905) 567-5246
 Email: yayub@jainconsultants.com

PROJECT
 1050 KLONDIKE ROAD
 OTTAWA, ONTARIO, K2K 1X7

DRAWING TITLE
 SITE SERVICING PLAN

SCALE: 1:150
 DATE: Jun. 27, 22
 DRAWN BY: CC
 CHECKED BY: YA
 DWG No. C101

GENERAL NOTES

- CONTRACTOR IS RESPONSIBLE FOR ALL LAYOUT FOR CONSTRUCTION.
- ALL ELEVATIONS ARE GEODETIC AND UTILIZE METRIC UNITS.
- JOB BENCH MARK - CONFIRM WITH JIC LTD. PRIOR TO UTILIZATION.
- ALL DIMENSIONS ARE IN METERS UNLESS OTHERWISE STATED. ALL DRAWINGS SHOULD NOT BE SCALED BY THE CONTRACTOR. ANY MISSING OR QUESTIONABLE DIMENSIONS ARE TO BE CONFIRMED WITH THE CONSULTANT IN WRITING.
- CONSTRUCTION SHALL BE IN ACCORDANCE WITH CITY OF OTTAWA AND ONTARIO PROVINCIAL STANDARD DRAWING SUPPLEMENTS WHERE APPLICABLE AND ONTARIO PROVINCIAL STANDARDS SHALL APPLY WHERE NO CITY STANDARDS ARE AVAILABLE.
- ANY DISCREPANCIES, INTERPRETATIONS, CHANGES AND ADDITIONS TO THESE DRAWINGS MUST BE BROUGHT TO THE ATTENTION OF THE ENGINEER, WHEN NOTED AND BEFORE PROCEEDING WITH CONSTRUCTION WORKS.
- REFER TO ARCHITECT'S SITE PLAN FOR BUILDING DIMENSIONS AND SITE LAYOUT DIMENSIONS AND LAYOUT.

- INFORMATION SHALL BE CONFIRMED PRIOR TO COMMENCEMENT OF CONSTRUCTION.
- REFER TO THE LANDSCAPE ARCHITECT'S PLAN FOR SIDEWALK, PATHWAYS, PLANTING AND OTHER LANDSCAPE FEATURE MATERIALS AND LOCATIONS.
- FOR GEOTECHNICAL INFORMATION REFER TO THE GEOTECHNICAL INVESTIGATION REPORT PREPARED BY GEMTEC CONSULTING ENGINEERS AND SCIENTISTS LTD. DATED OCTOBER 2020.
- ALL DISTURBED AREAS TO BE REINSTATED TO EQUAL OR BETTER CONDITION. ALL NEW WORK SHALL TIE INTO EXISTING.
- ALL GROUND SURFACES SHALL BE EVENLY GRADED WITHOUT PONDING AREAS AND WITHOUT LOW POINTS EXCEPT WHERE APPROVED SWALE OR CATCHBASIN OUTLETS ARE PROVIDED.
- ALL EDGES OF DISTURBED PAVEMENT SHALL BE SAWCUT TO FORM A NEAT AND STRAIGHT LINE PRIOR TO PLACING NEW PAVEMENT.
- CONTRACTOR IS TO COMPLY WITH THE CITY OF OTTAWA REQUIREMENTS FOR TRAFFIC CONTROL WHEN WORKING ON CITY STREETS.

- ALL MATERIAL SUPPLIED AND PLACED FOR PARKING LOT AND ACCESS ROAD CONSTRUCTION SHALL BE TO CITY OF OTTAWA AND OPSS STANDARDS AND SPECIFICATIONS UNLESS OTHERWISE NOTED (CONSTRUCTION OPSS 206, 310 & 314 MATERIALS OPSS 1001, 1003 & 1010).
- THE CONTRACTOR SHALL CONFIRM LOCATIONS AND ELEVATIONS OF EXISTING SERVICES AND STRUCTURES TO BE CONNECTED TO AND EXISTING SERVICES THAT MAY BE DAMAGED OR CAUSE CONFLICTS PRIOR TO CONSTRUCTION OF ANY NEW SEWER, WATER AND/OR STORM WATER WORKS. THE ENGINEER SHALL BE INFORMED IMMEDIATELY OF ANY ERRORS, DISCREPANCIES, CONFLICTS, OMISSIONS ETC THAT ARE FOUND. DO NOT CONTINUE CONSTRUCTION IN AREAS WHERE DISCREPANCIES APPEAR UNTIL SUCH DISCREPANCIES HAVE BEEN RESOLVED.
- THE CONTRACTOR SHALL PROTECT ANY SUCH EXISTING SERVICES & FACILITIES. SUCH REQUIRED MEASURES INCLUDE, BUT ARE NOT LIMITED TO: ENSURE ALL CONCERNED UTILITIES HAVE LOCATED THEIR PLANT PRIOR TO ANY EXCAVATING, LOCATE AND FLAG/PAINT THE LOCATIONS OF OTHER U/G PLANT WHICH MIGHT BE

- DAMAGED BY EXCAVATION AND CONSTRUCTION TRAFFIC. HAND DIG IN PROXIMITY TO EXISTING BURIED SERVICES TO LOCATE THEM WITHOUT ANY RESULTING DAMAGE, BRACE AND SUPPORT WHERE REQUIRED.
- THE CONTRACTOR SHALL IMPLEMENT BEST MANAGEMENT PRACTICES FOR THE PROTECTION OF THE AREA'S DRAINAGE SYSTEM AND THE RECEIVING WATERCOURSE DURING CONSTRUCTION ACTIVITIES. THIS INCLUDES LIMITING THE AMOUNT OF EXPOSED SOIL, USING FILTER CLOTH UNDER GRATES OF CATCHBASINS AND MANHOLES AND INSTALLING SILT FENCES AND OTHER EFFECTIVE SEDIMENT TRAPS. THE CONTRACTOR ACKNOWLEDGES THAT FAILURE TO IMPLEMENT APPROPRIATE EROSION AND SEDIMENT CONTROL MEASURES MAY BE SUBJECT TO PENALTIES IMPOSED BY ANY APPLICABLE REGULATORY AGENCY.
- DESIGN ELEVATIONS GIVEN ON THESE PLANS ARE TO BE ADHERED TO WITH NO CHANGES WITHOUT PRIOR WRITTEN APPROVAL BY JIC LTD. SURFACE PONDING STORAGE VOLUMES AND INLET CONTROL DEVICE DIMENSIONS MUST COMPLY WITH THE DESIGN REPORT PREPARED BY JIC LTD. FOR THIS PROJECT.

- THE CONTRACTOR IS RESPONSIBLE FOR AND SHALL PROVIDE FOR DEWATERING, SUPPORT AND PROTECTION OF EXCAVATION AND TRENCHING AS WELL AS RELEASE OF ANY PUMPED GROUND WATER IN A CONTROLLED AND APPROVED MANNER. THE CONTRACTOR SHALL APPLY FOR A PERMIT TO TAKE WATER FROM THE MINISTRY OF ENVIRONMENT IF MORE THAN 50,000 LITERS PER DAY OF GROUNDWATER IS PUMPED FOR CONSTRUCTION ACTIVITIES.
- FOR TOPOGRAPHICAL INFORMATION REFER TO PLAN PREPARED BY ANNIS, O'SULLIVAN, VOLLEBEK LTD. FOR LEGAL PROPERTY LINE DESCRIPTIONS.
- CITY INSPECTOR IS TO BE NOTIFIED OF ANY WORKS IN THE ROW WITH SUFFICIENT NOTICE.
- CLAY SEAL TO BE AS PER OPSS 802.095.
- SHOULD ANY CONDITIONS AT THE SITE BE ENCOUNTERED WHICH DIFFER FROM THE TEST LOCATIONS IDENTIFIED IN THE GEOTECHNICAL REPORT, GEMTEC'S GEOTECHNICAL ENGINEER IS TO BE NOTIFIED IMMEDIATELY IN ORDER TO PERMIT REASSESSMENT OF THE GEOTECHNICAL RECOMMENDATIONS.

ROADWAYS & CURBS

- ASPHALT REINSTATEMENT AS PER CITY OF OTTAWA STANDARD DRAWING R10.
- CURBS TO BE CONCRETE BARRIER CURBS AS PER CITY OF OTTAWA STANDARD DRAWING SC1.1
- THE CONTRACTOR SHALL COMPLETE ALL RESTORATION WITHIN CITY ROWS TO A CONDITION EQUAL TO ORIGINAL OR BETTER AND TO THE SATISFACTION OF THE MUNICIPAL AUTHORITIES.

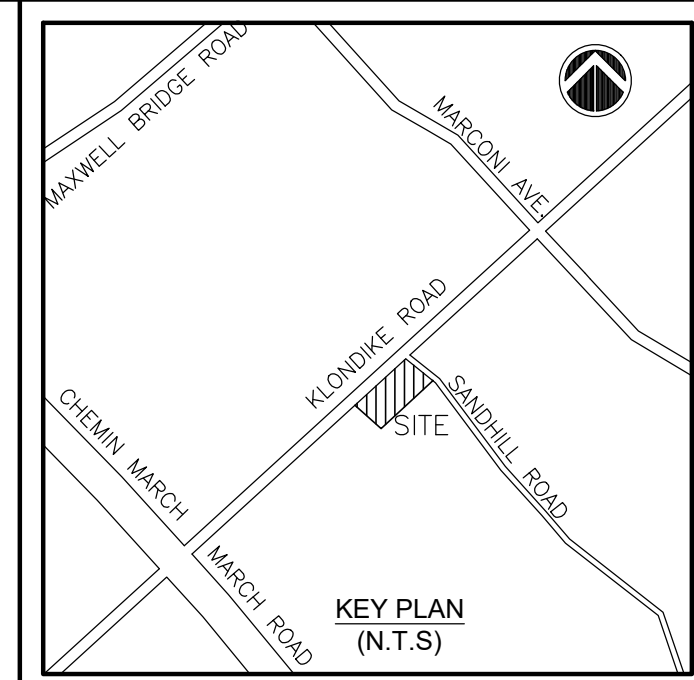
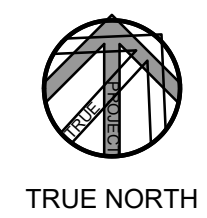

- DRAWING REFERENCES**
- THE SITE PLAN MUST BE READ IN CONJUNCTION WITH ARCHITECTURAL, LANDSCAPING, ELECTRICAL & STRUCTURAL PLANS.
 - FOR SERVING PLAN, REFER DRAWING C101.
 - FOR EROSION CONTROL, CITY STANDARD NOTES & DETAILS REFER DRAWING C103.

LEGAL DESCRIPTION:
 PLAN OF SURVEY & TOPOGRAPHIC INFORMATION PREPARED BY ANNIS, O'SULLIVAN, VOLLEBEK LTD. (OLS), IDENTIFIED AS PART OF LOT 10, CONCESSION 4 GEOGRAPHIC TOWNSHIP OF MARCH CITY OF OTTAWA

BEARING NOTE:
 BEARINGS ARE GRID, DERIVED FROM CAN-NET 2016 REL TIME NETWORK GPS OBSERVATIONS, MTM ZONE 9 (76° 30' WEST LONGITUDE) NAD-83 (ORIGINAL).

LEGEND

- EXISTING ELEVATION (SURVEY)
- PROPOSED STORM MANHOLE
- PROPOSED CATCH BASIN
- EXISTING MANHOLE
- EXISTING CATCH BASIN
- EXISTING VALVE CHAMBER (WATERMAIN)
- EXISTING FIRE HYDRANT
- EXISTING ELEVATION TO REMAIN
- PROPOSED ELEVATION
- PROP. TOP OF CURB ELEVATION
- ROAD ELEVATIONS BY OTHERS
- SLOPE BY OTHERS
- PROPOSED SLOPE
- OVERLAND FLOW ROUTE
- CURB STOP
- ROOF DRAIN
- TOP OF FOUNDATION ELEVATION
- UNDERSIDE OF FOOTING ELEVATION
- FINISHED FLOOR ELEVATION

REVISION

No.	DESCRIPTION	DATE
3	ISSUED FOR SPA	JUN 27, 22
2	ISSUED FOR SPA	NOV 25, 21
1	ISSUED FOR SPA	MAY 19, 21

No.	DESCRIPTION	DATE
3	ISSUED FOR SPA	JUN 27, 22
2	ISSUED FOR SPA	NOV 25, 21
1	ISSUED FOR SPA	MAY 19, 21

JAIN
 Jain Infrastructure Consultants Ltd.
 7405 EAST DANBRO CRESCENT
 MISSISSAUGA, ON L5N 6P8
 TEL: (905) 285-9900, FAX: (905) 567-5246
 Email: yayub@jainconsultants.com

PROJECT
 1050 KLONDIKE ROAD
 OTTAWA, ONTARIO, K2K 1X7

DRAWING TITLE
 SITE GRADING PLAN

SCALE: 1:150
DATE: Jun. 27, 22
DRAWN BY: CC
CHECKED BY: YA

DWG No.
C102

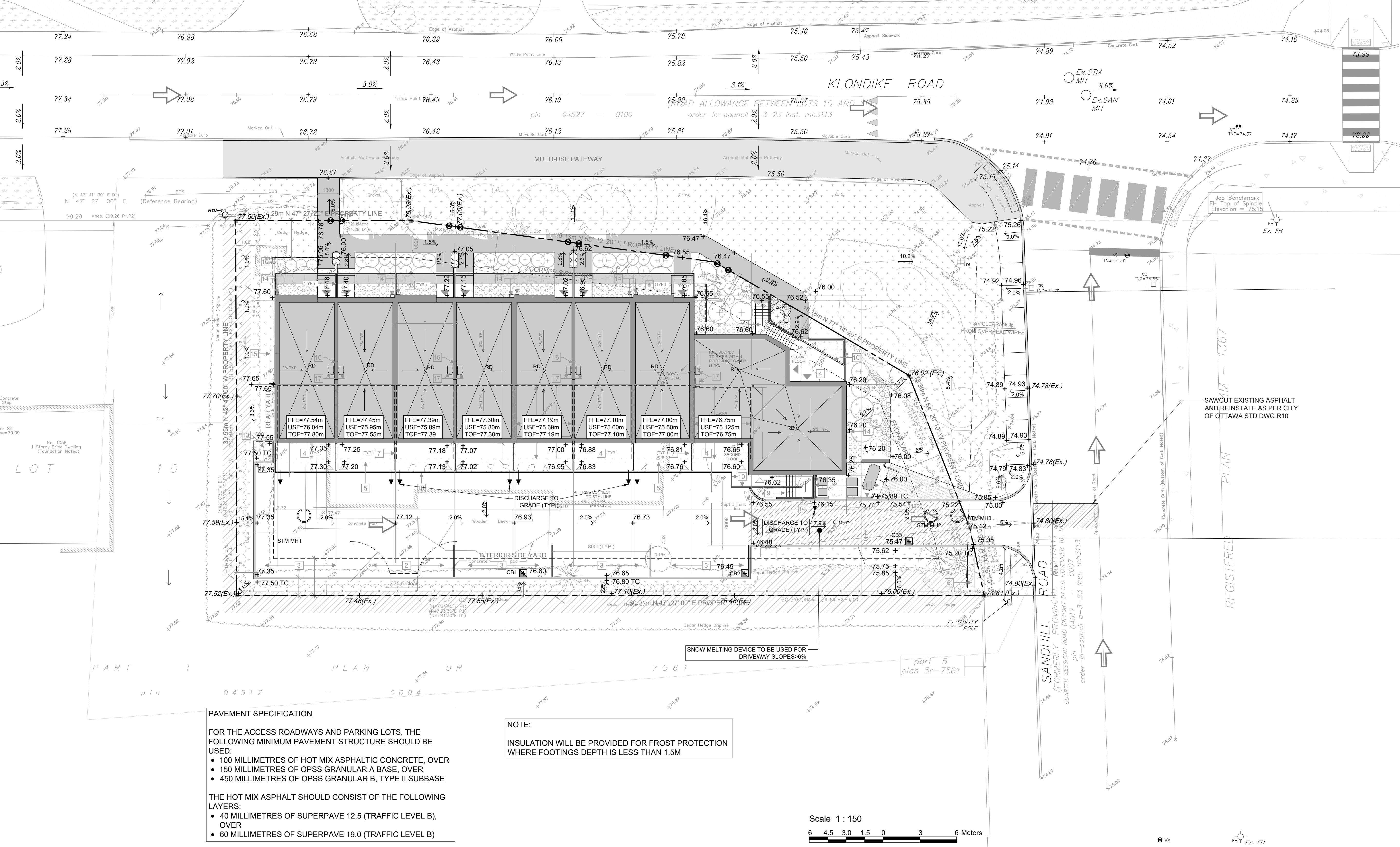

PAVEMENT SPECIFICATION

FOR THE ACCESS ROADWAYS AND PARKING LOTS, THE FOLLOWING MINIMUM PAVEMENT STRUCTURE SHOULD BE USED:

- 100 MILLIMETRES OF HOT MIX ASPHALTIC CONCRETE, OVER
- 150 MILLIMETRES OF OPSS GRANULAR A BASE, OVER
- 450 MILLIMETRES OF OPSS GRANULAR B, TYPE II SUBBASE

THE HOT MIX ASPHALT SHOULD CONSIST OF THE FOLLOWING LAYERS:

- 40 MILLIMETRES OF SUPERPAVE 12.5 (TRAFFIC LEVEL B), OVER
- 60 MILLIMETRES OF SUPERPAVE 19.0 (TRAFFIC LEVEL B)

NOTE:
 INSULATION WILL BE PROVIDED FOR FROST PROTECTION WHERE FOOTINGS DEPTH IS LESS THAN 1.5M

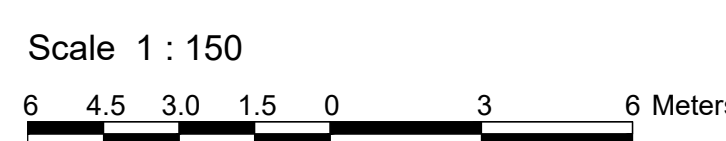

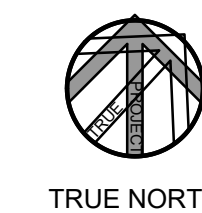

EROSION AND SEDIMENT CONTROL NOTES

1. THE CONTRACTOR SHALL IMPLEMENT BEST MANAGEMENT PRACTICES, TO PROVIDE FOR PROTECTION OF THE AREA DRAINAGE SYSTEM AND THE RECEIVING WATERCOURSE, DURING CONSTRUCTION ACTIVITIES. THIS INCLUDES LIMITING THE AMOUNT OF EXPOSED SOIL, USING FILTER CLOTH UNDER THE GRATES OF CATCHBASINS AND MANHOLES, AND INSTALLING SILT FENCES AND OTHER EFFECTIVE SEDIMENT TRAPS. THE CONTRACTOR ACKNOWLEDGES THAT FAILURE TO IMPLEMENT APPROPRIATE EROSION AND SEDIMENT CONTROL MEASURES MAY BE SUBJECT TO PENALTIES IMPOSED BY ANY APPLICABLE REGULATORY AGENCY.
2. THE SEDIMENT CONTROL MEASURES SHALL ONLY BE REMOVED WHEN, IN THE OPINION OF THE ENGINEER, THE MEASURES ARE NO LONGER REQUIRED. NO CONTROL MEASURES MAY BE PERMANENTLY REMOVED WITHOUT PRIOR AUTHORIZATION FROM THE ENGINEER.
3. REGULAR INSPECTION AND MAINTENANCE OF THE EROSION AND SEDIMENT MEASURES SHALL BE UNDERTAKEN. THE IMPLEMENTATION AND ADJUSTMENT AND/OR CORRECTIVE MAINTENANCE OF THE EROSION AND SEDIMENT MEASURES IS AN INTEGRAL PART OF THE PLAN AND MUST BE PERFORMED.
4. GEOTEXTILE FILTER FABRIC SHALL BE PLACED BETWEEN THE STRUCTURE FRAME AND COVER FOR ALL MANHOLES, CATCHBASINS, AND CATCHBASIN MANHOLES IN THE VICINITY OF WORK.
5. THE CONTRACTOR SHALL MAINTAIN ADJACENT ROADS IN A CLEAN CONDITION AT ALL TIMES.
6. PROVIDE MUD MATS AT SITE CONSTRUCTION ENTRANCE(S) AND EGRESS(S).

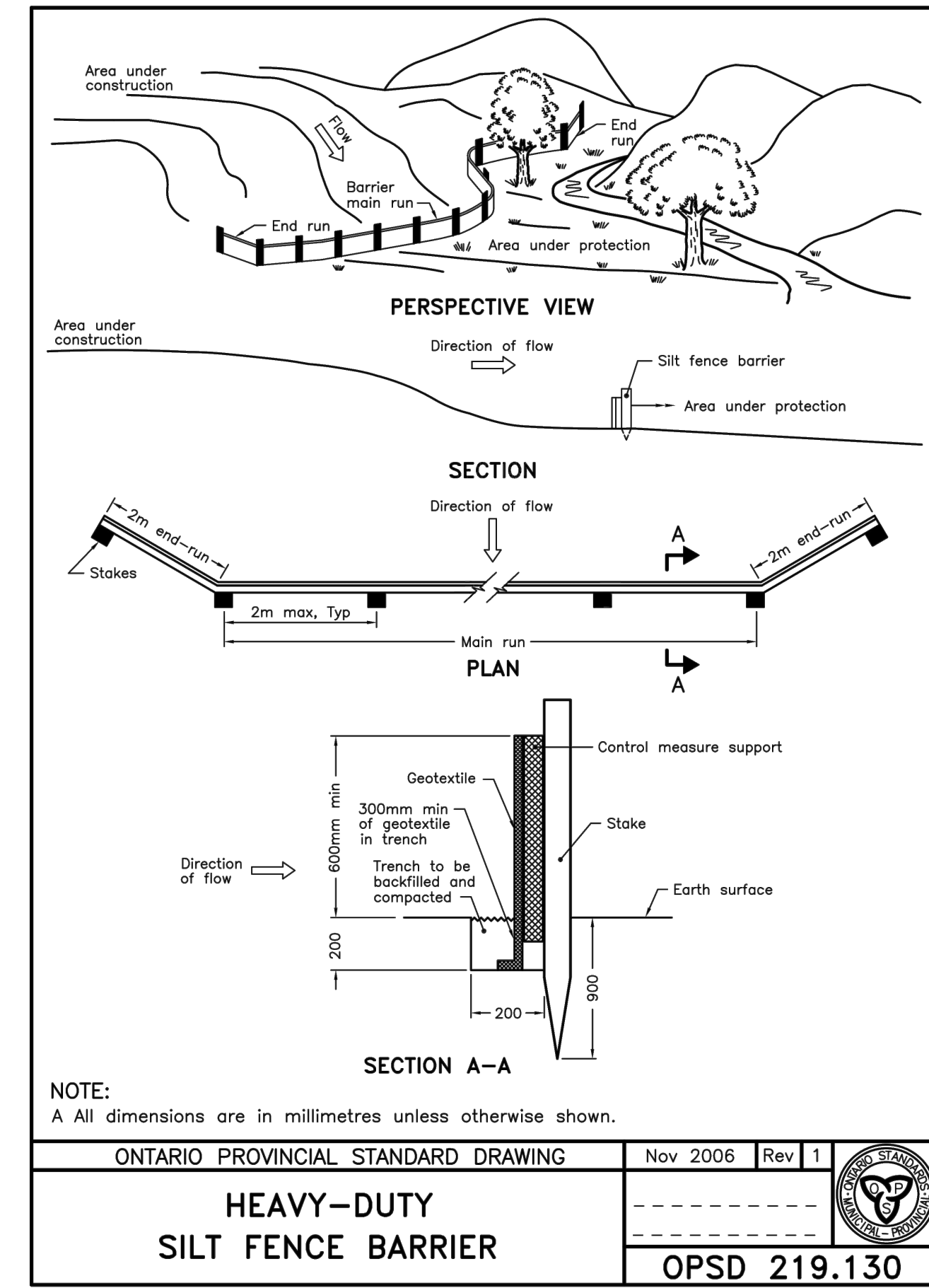
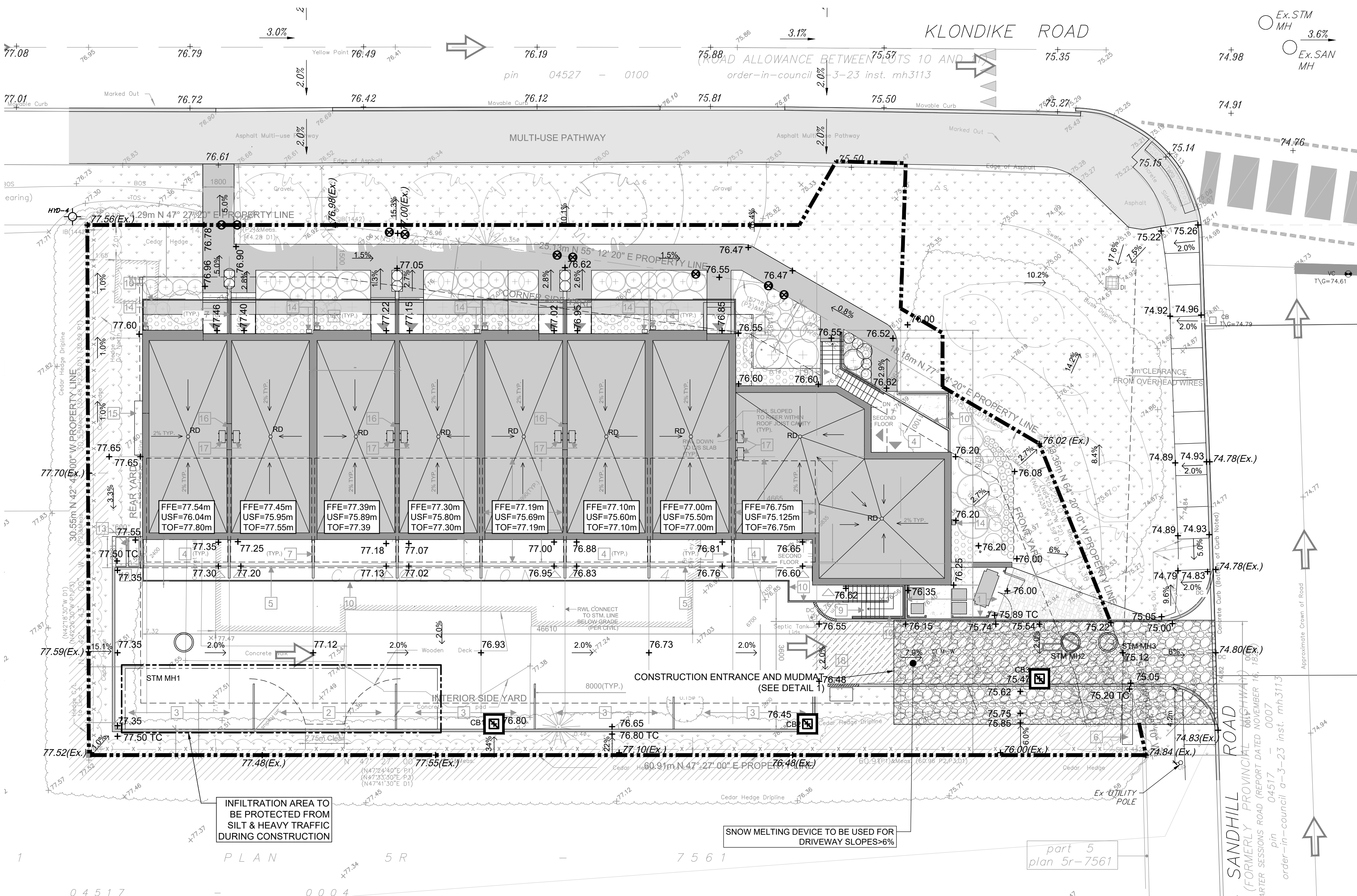
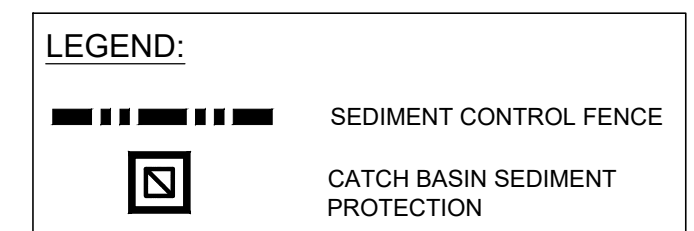
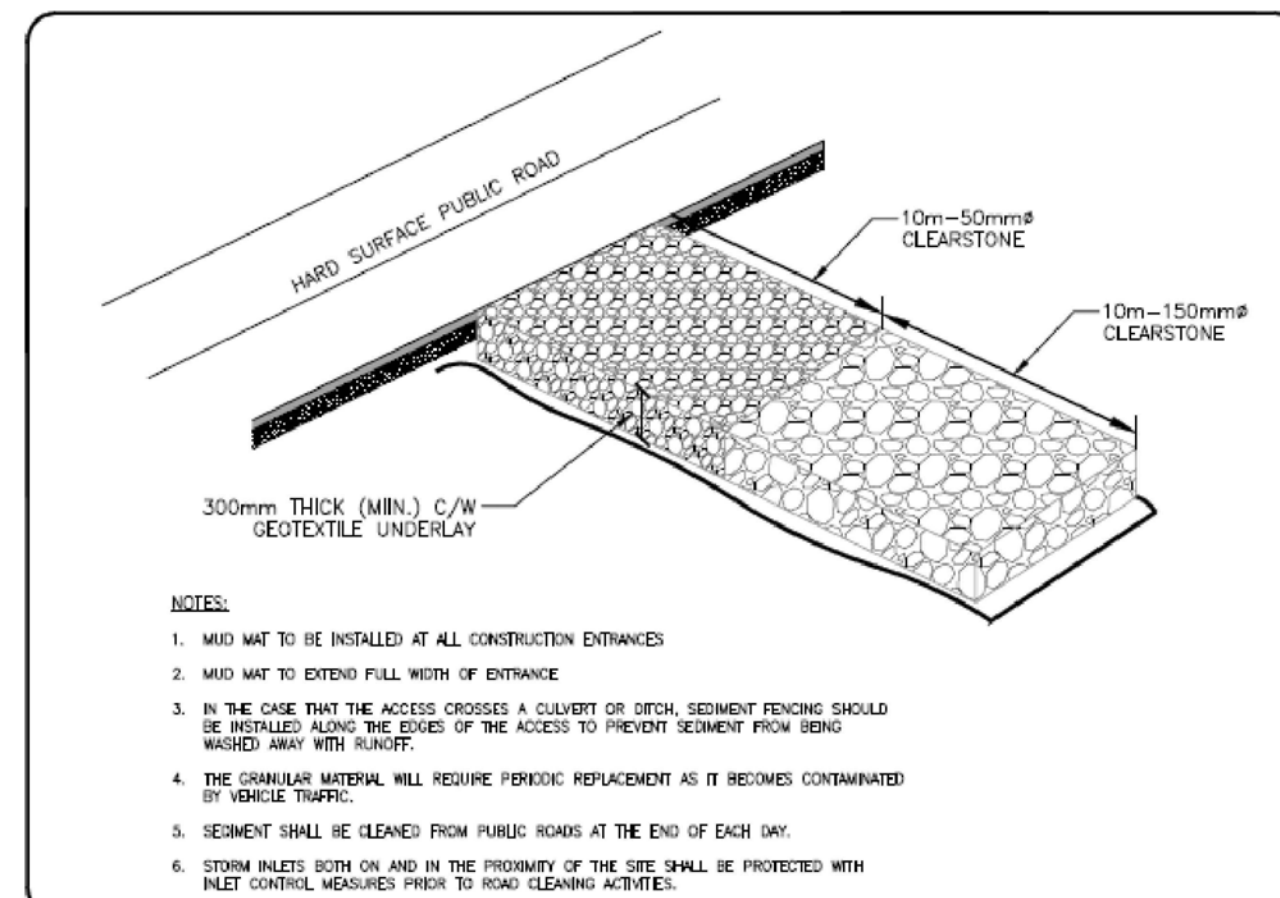
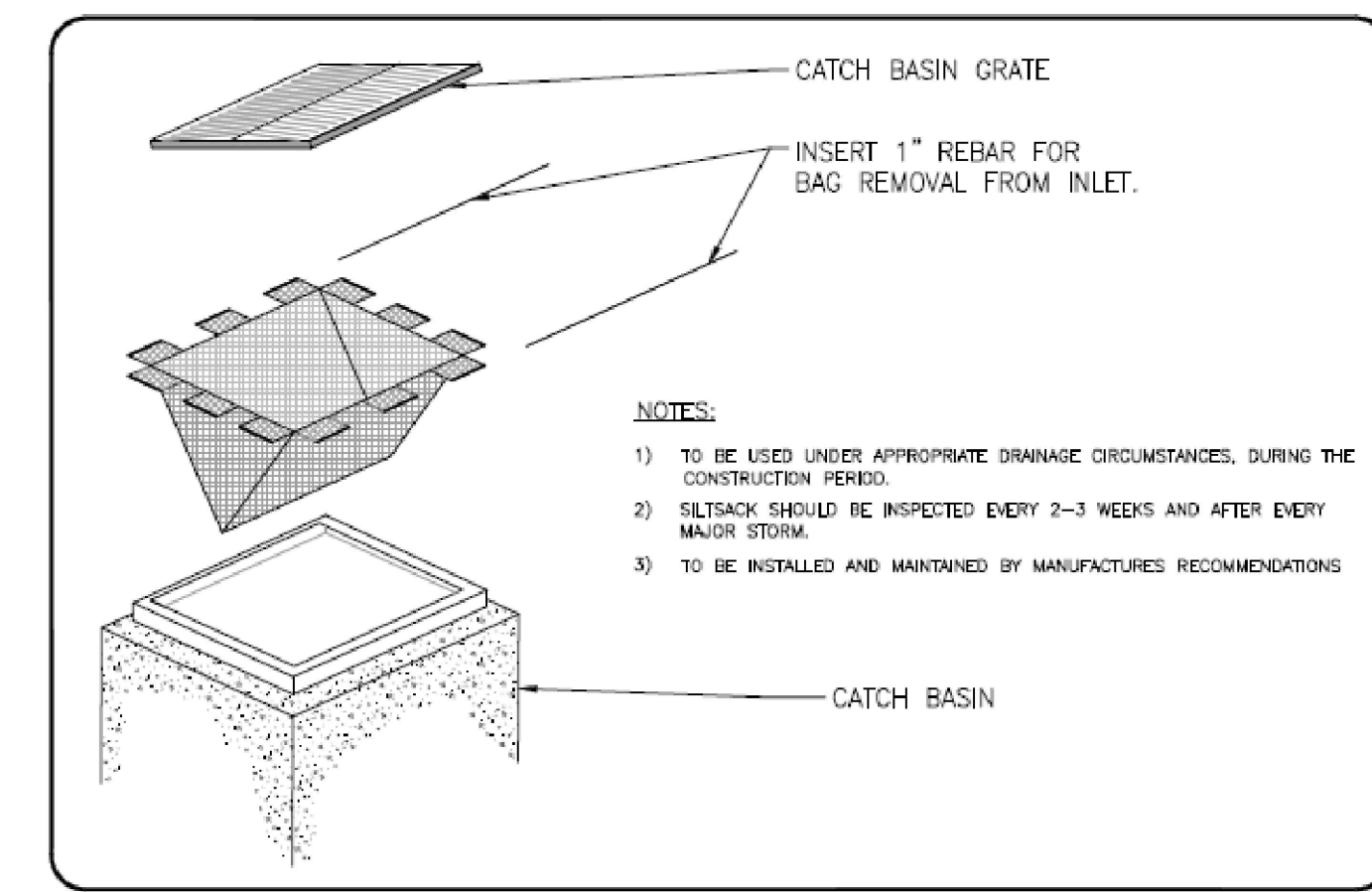

- #### DRAWING REFERENCES
1. THE SITE PLAN MUST BE READ IN CONJUNCTION WITH ARCHITECTURAL, LANDSCAPING, ELECTRICAL & STRUCTURAL PLANS.
 2. FOR SERVICING PLAN, REFER DRAWING C101.
 3. FOR GRADING PLAN, REFER DRAWING C102.

LEGAL DESCRIPTION:

PLAN OF SURVEY & TOPOGRAPHIC INFORMATION PREPARED BY ANNIS, O'SULLIVAN, VOLLEBEKK LTD. (O.L.S.), IDENTIFIED AS PART OF LOT 10, CONCESSION 4 GEOGRAPHIC TOWNSHIP OF MARCH CITY OF OTTAWA

BEARING NOTE:

BEARINGS ARE GRID, DERIVED FROM CAN-NET 2016 REL TIME NETWORK GPS OBSERVATIONS, MTM ZONE 9 (76° 30' WEST LONGITUDE) NAD-83 (ORIGINAL).

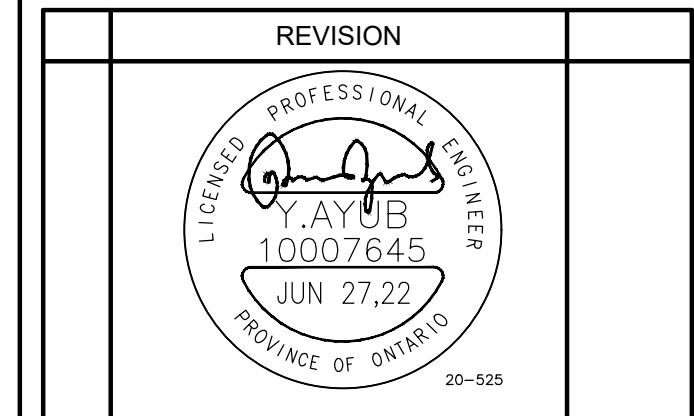
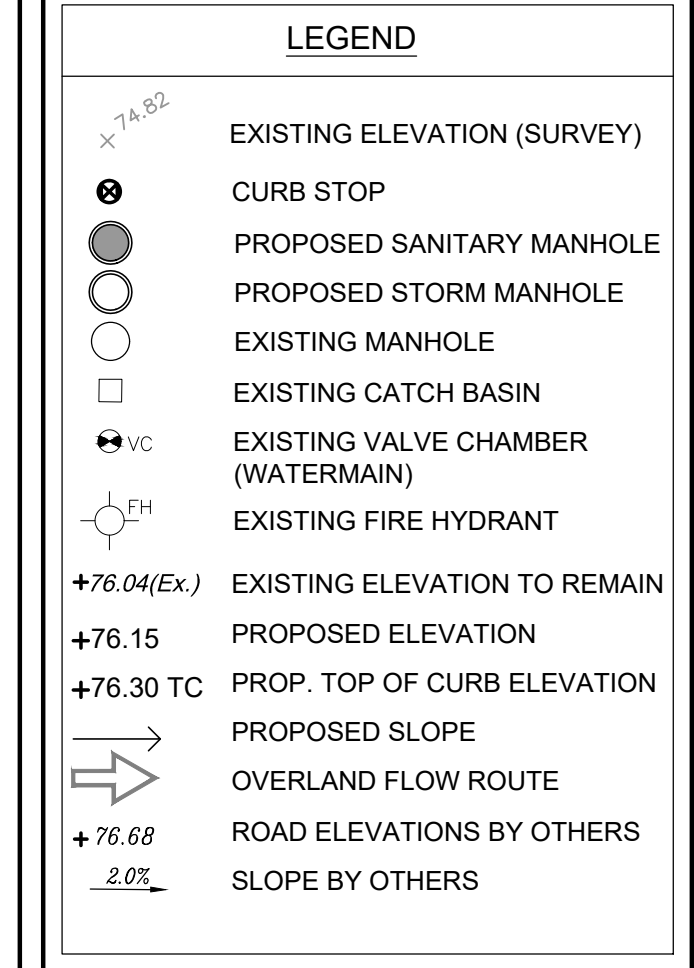

No.	DESCRIPTION	DATE
3	ISSUED FOR SPA	JUN 27, 22
2	ISSUED FOR SPA	NOV 25, 21
1	ISSUED FOR SPA	MAY 19, 21

JAIN
 Jain Infrastructure Consultants Ltd.
 7405 EAST DANBRO CRESCENT
 MISSISSAUGA, ON L5N 6P8
 TEL: (905) 285-9900, FAX: (905) 567-5246
 Email: yayub@jainconsultants.com

PROJECT
1050 KLONDIKE ROAD
 OTTAWA, ONTARIO, K2K 1X7

DRAWING TITLE
EROSION CONTROL PLAN & DETAILS

SCALE: 1:150
 DATE: Jun. 27, 22
 DRAWN BY: CC
 CHECKED BY: YA

DWG No.
C103

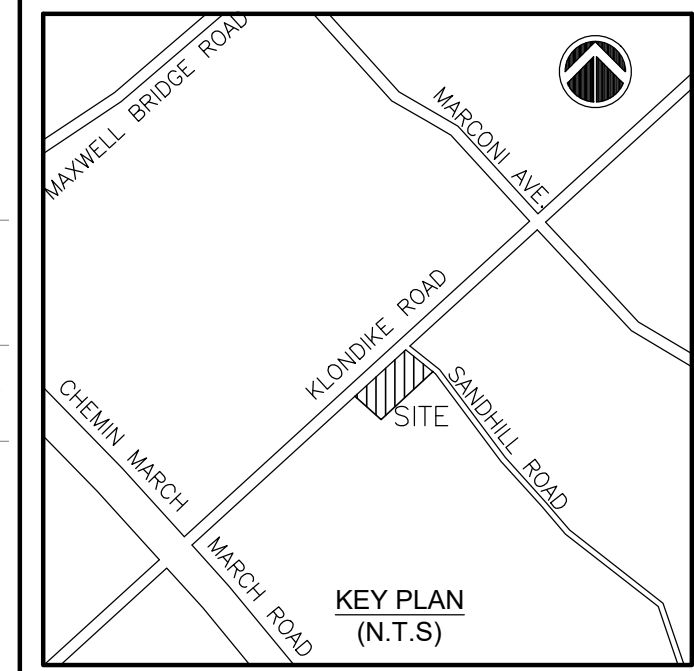
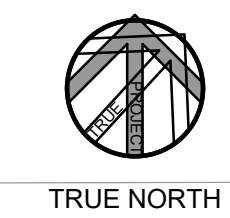

DRAWING REFERENCES
 1. THE SITE PLAN MUST BE READ IN CONJUNCTION WITH ARCHITECTURAL, LANDSCAPING, ELECTRICAL & STRUCTURAL PLANS.
 2. FOR SERVICING PLAN, REFER DRAWING C101.
 3. FOR EROSION CONTROL, CITY STANDARD NOTES & DETAILS REFER DRAWING C103.

LEGAL DESCRIPTION:
 PLAN OF SURVEY & TOPOGRAPHIC INFORMATION PREPARED BY ANNIS, O'SULLIVAN, VOLLEBEKK LTD. (O.S.), IDENTIFIED AS PART OF LOT 10, CONCESSION 4 GEOGRAPHIC TOWNSHIP OF MARCH CITY OF OTTAWA

BEARING NOTE:
 BEARINGS ARE GRID, DERIVED FROM CAN-NET 2016 REL TIME NETWORK GPS OBSERVATIONS, MTM ZONE 9 (76° 30' WEST LONGITUDE) NAD-83 (ORIGINAL).

LEGEND

	GRAVEL REMOVAL
	BUILDING/SHED REMOVAL
	WOODEN DECK REMOVAL
	CONCRETE WALKWAY/PAD REMOVAL
	SEPTIC TANK REMOVAL
	RETAINING WALL REMOVAL

REVISION

2	ISSUED FOR SPA	JUN 27, 22
1	ISSUED FOR SPA	NOV 25, 21

No.	DESCRIPTION	DATE
-----	-------------	------

JAIN
 Jain Infrastructure Consultants Ltd.
 7405 EAST DANBRO CRESCENT
 MISSISSAUGA, ON L5N 6P8
 TEL: (905) 285-9900, FAX: (905) 567-5246
 Email: yayub@jainconsultants.com

PROJECT
 1050 KLONDIKE ROAD
 OTTAWA, ONTARIO, K2K 1X7

DRAWING TITLE
 REMOVAL & DEMOLITION PLAN

SCALE:	1: 150	DWG No.
DATE:	Jun. 27, 22	
DRAWN BY:	CC	
CHECKED BY:	YA	

C105

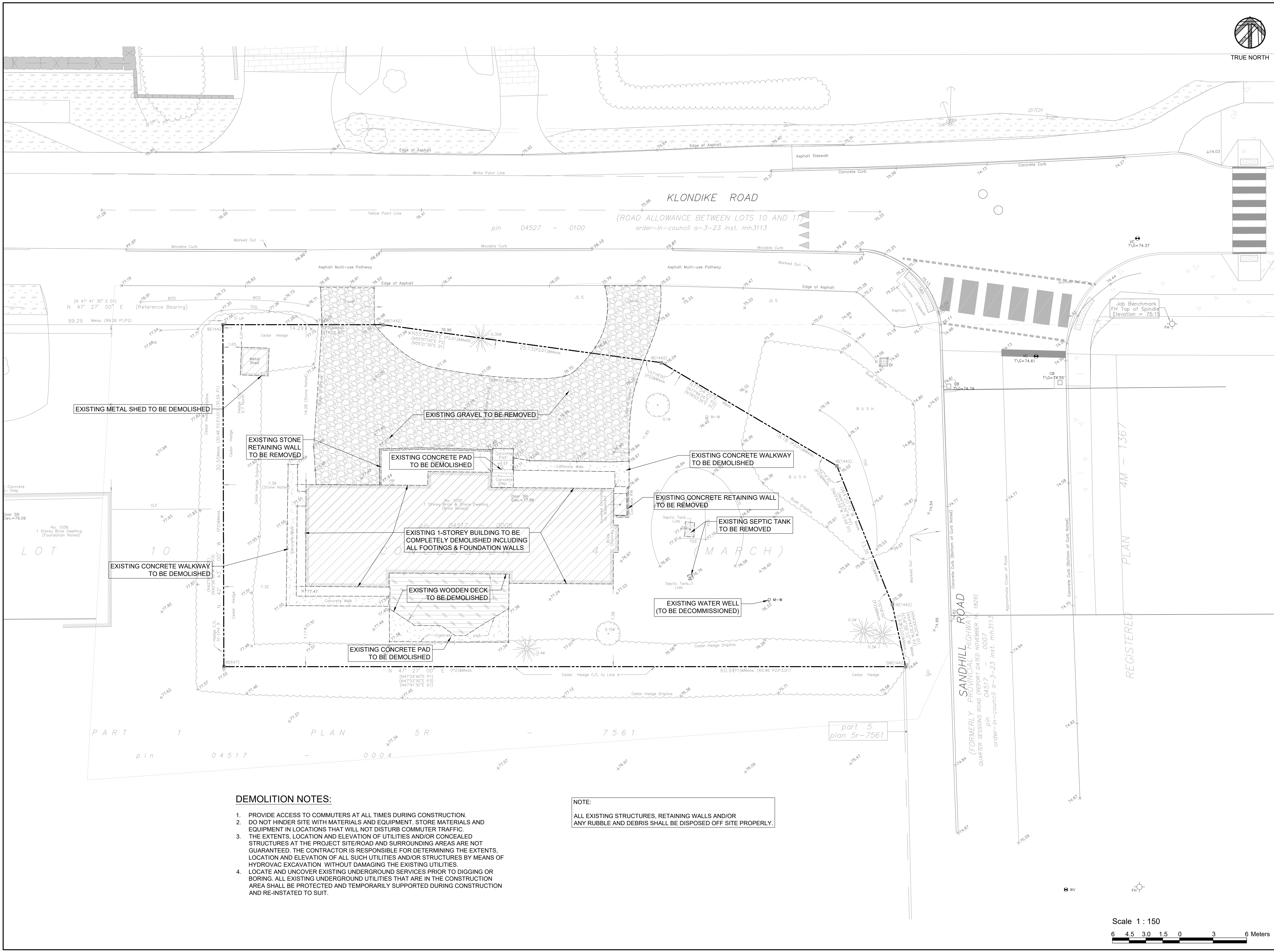

- DEMOLITION NOTES:**
1. PROVIDE ACCESS TO COMMUTERS AT ALL TIMES DURING CONSTRUCTION. DO NOT HINDER SITE WITH MATERIALS AND EQUIPMENT. STORE MATERIALS AND EQUIPMENT IN LOCATIONS THAT WILL NOT DISTURB COMMUTER TRAFFIC.
 2. THE EXTENTS, LOCATION AND ELEVATION OF UTILITIES AND/OR CONCEALED STRUCTURES AT THE PROJECT SITE/ROAD AND SURROUNDING AREAS ARE NOT GUARANTEED. THE CONTRACTOR IS RESPONSIBLE FOR DETERMINING THE EXTENTS, LOCATION AND ELEVATION OF ALL SUCH UTILITIES AND/OR STRUCTURES BY MEANS OF HYDROVAC EXCAVATION WITHOUT DAMAGING THE EXISTING UTILITIES.
 3. LOCATE AND UNCOVER EXISTING UNDERGROUND SERVICES PRIOR TO DIGGING OR BORING. ALL EXISTING UNDERGROUND UTILITIES THAT ARE IN THE CONSTRUCTION AREA SHALL BE PROTECTED AND TEMPORARILY SUPPORTED DURING CONSTRUCTION AND RE-INSTATED TO SUIT.

NOTE:
 ALL EXISTING STRUCTURES, RETAINING WALLS AND/OR ANY RUBBLE AND DEBRIS SHALL BE DISPOSED OFF SITE PROPERLY.

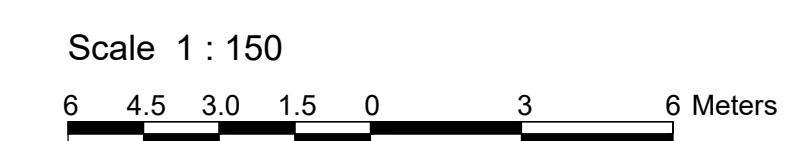

#18639

Appendix B
Correspondence with Regulatory Authorities

Yasar Ayub

Subject: FW: 1050 Klondike Road - preconsultation meeting notes

----- Forwarded Message -----

From: McCreight, Laurel <laurel.mccreight@ottawa.ca>

To: Deborah Belfie <belfied@rogers.com>

Sent: Tuesday, May 26, 2020, 03:52:36 p.m. EDT

Subject: Pre-Consultation Follow-Up: 1050 Klondike Road

Hi Debbie,

Please refer to the below regarding the Pre-Application meeting held on May 21, 2020 for the property at 1050 Klondike Road for a Zoning By-law Amendment and Site Plan Control Application for a 4-storey apartment building. I have also attached the required Plans & Study List for application submission.

Below are staff's preliminary comments based on the information available at the time of the pre-consultation meeting:

Planning / Urban Design

- The parking on the ground floor in the proposed design concept must be redesigned, as it will have significant negative impacts on the public realm.
- The proposed design concept requires more animation to both Klondike and Sandhill. This could include revising the proposal with:
 - Removing the two vehicular accesses and provide only one access off Sandhill;
 - Removing the vehicle maneuvering area in the front encroaching into the public right of way;
 - Revising the location of the garbage room that directly faces the street;
 - Providing underground parking and
 - Relocating the bike parking away from the façade of the building.
- The majority of the units, which are south facing, are approximately 3 metres away from the property line. This could be concerning depending on the development potential on the abutting property.
- The road closure at the corner of Klondike and Sandhill, if possible, can potentially alleviate some pressures and offer some flexibilities for design. Regardless of the final lot configuration, the design should:
 - Animate both public streets (neither ground floor parking nor blank walls should be allowed);
 - Improve public realm through adequate provision of landscaping and architecture design;
 - Ensure access to natural lights for all units in the long run taking into consideration development potential on abutting properties; and
 - Provide adequate private amenities.
- A scoped Design Brief is required for the rezoning application. The Terms of Reference of the Design Brief is attached to provide guidance.
- You are encouraged to contact the Ward Councillor, Councillor [Jenna Sudds](#), about the proposal.

Engineering

- The Servicing Study Guidelines for Development Applications are available here.
- Servicing and site works shall be in accordance with the following documents:
 - Ottawa Sewer Design Guidelines (October 2012)
 - Ottawa Design Guidelines – Water Distribution (2010)
 - Geotechnical Investigation and Reporting Guidelines for Development Applications in the City of Ottawa (2007)
 - City of Ottawa Slope Stability Guidelines for Development Applications (revised 2012)
 - City of Ottawa Environmental Noise Control Guidelines (January 2016)
 - City of Ottawa Park and Pathway Development Manual (2012)
 - City of Ottawa Accessibility Design Standards (2012)
 - Ottawa Standard Tender Documents (latest version)
 - Ontario Provincial Standards for Roads & Public Works (2013)
- Record drawings and utility plans are also available for purchase from the City (Contact the City's Information Centre by [email](#) or by phone at (613) 580-2424 x.44455).
- For the re-zoning application, please provide a site serviceability study proving the site can be serviced by the existing municipal infrastructure and discuss any improvements that may be required to service the proposed site.
- Sanitary Infrastructure
 - There is an available 200mm diameter PVC sanitary sewer located on Klondike Road. However, it currently does not front the proposed site.
 - A sanitary sewer extension within the Klondike Road Right-Of-Way (ROW) will be required to service this site. The sanitary sewer can be extended solely the +/-20m required to service the site, and does not need to extend the full length of the site's Klondike Road frontage.
 - The proponent will be required to demonstrate what the expected sanitary flows from the proposed site will be and show that the existing sanitary sewer infrastructure can accommodate the proposed site flows without any adverse affects.
 - The existing sanitary sewer on Klondike Road connects to the Briar Ridge Pump Station (BRPS). This pump station currently has limited capacity. Upgrades to the BRPS are expected to be completed by Dec 2021 or early 2022.
 - Due to the municipal sanitary sewer extension a Ministry of Environment, Conservation and Parks Environmental Compliance Approval (MECP ECA) will be required and will be reviewed under the Transfer of Review program (Standard Works) with the City of Ottawa.
 - Also due to the municipal sanitary extension, a Municipal Consent (MC) circulation will be required after or in the later stages of the Site Plan Application stage. The ROW Approvals Department at the City, may, to their review and discretion, exempt the proposed extension from the MC Circulation process.
- Watermain
 - There is an available 305mm diameter PVC watermain fronting the site along Sandhill Road. However, looping of the Klondike Road watermain (from March Road stub to the Sandhill Road stub) is preferred.
 - Water frontage charges will not apply.
 - If a watermain extension along Klondike Road is pursued an MECP Form 1 will need to be completed.
 - Drinking Water Boundary condition requests must include the location of the service connection and the expected loads required by the proposed development. Please provide the following information:
 - a. Location of service (map/plan view)
 - b. (Draft) site plan or similar plan for building location
 - c. Fire flow demand: ____ L/s (as per FUS, 1999)
 - d. Average daily demand: ____ L/s.
 - e. Maximum daily demand: ____ L/s.

- f. Maximum hourly daily demand: ___ L/s.
 - g. Supporting calculations for domestic demands
 - h. Supporting calculations for FUS required fire flow
- The Stormwater Management Criteria, for the subject site, is to be based on the following:
 - There is an available 675mm diameter concrete storm sewer located on Sandhill Road conveying flow to a ditch upstream of “Pond C”.
 - Based on both the Shirley’s Brook Floodplain Analysis and SWM Report (Klondike Road Development Lands, prepared by Novatech, May 2006) and the Shirley’s Brook SWM Facility “C” Detailed Design Report (prepared by Novatech, 2006), it appears that Pond “C” was sized to service the 1050 Klondike Road parcel. Please demonstrate that the existing storm sewer and pond have capacity to service this proposed development (quantity and quality control).
 - Refer to the SWM design criteria in the Shirley’s Brook SWM Facility “C” Detailed Design Report (prepared by Novatech, 2006) for the proposed development area:
 - a. Minor system allowable release rate of 85 L/s/ha;
 - b. Onsite major system storage of 50 m³/ha (please see the note below);
 - c. ICDs [are] installed in the roadway catchbasins to ensure flow into the storm sewer system does not exceed the 5-year runoff rates; and
 - d. HGL for 100-year event must have at least 0.3 m freeboard to the underside of footings.
 - IDF information derived from the Meteorological Services of Canada rainfall data, taken from the MacDonald Cartier Airport, collected 1966 to 1997.
 - The pre-development runoff coefficient or a maximum equivalent ‘C’ of 0.5, whichever is less (§ 8.3.7.3).
 - A calculated time of concentration (Cannot be less than 10 minutes).
 - Use of rooftop controls are recommended for this site, but are not limited to them, to meet the requirements.
 - Please note that there is a Special Area Development Charge for the subject site. Please refer to the current W-2 Development Charge Brochure attached. You can find By-Law No. 2019 – 163 online on the City of Ottawa website. Note that this is the Charge for 2019 and may change over time.
 - If the site plan changes to include underground parking, a Geotechnical Report will be required for the Re-Zoning application. If not, the Geotechnical Report will be required at Site Plan Application stage.

Please contact Infrastructure Project Manager [Gabrielle Schaeffer](#) for follow-up questions.

Transportation

- Only one access off Sandhill should be provided.
- On site plan:
 - Show all details of the roads abutting the site up to and including the opposite curb; include such items as pavement markings, accesses and/or sidewalks.
 - Turning templates will be required for all accesses showing the largest vehicle to access the site; required for internal movements and at all access (entering and exiting and going in both directions).
 - Show all curb radii measurements; ensure that all curb radii are reduced as much as possible
 - Show lane/aisle widths.
 - Provide dedicated pedestrian paths.
 - Grey out any area that will not be impacted by this application.

Please contact Transportation Project Manager, [Mike Giampa](#) for follow-up questions.

Other

Please refer to the links to "[Guide to preparing studies and plans](#)" and [fees](#) for general information. Additional information is available related to [building permits](#), [development charges](#), and the [Accessibility Design Standards](#). Be aware that other fees and permits may be required, outside of the development review process. You may obtain background drawings by contacting informationcentre@ottawa.ca.

These pre-consultation comments are valid for one year. If you submit a development application(s) after this time, you may be required to meet for another pre-consultation meeting and/or the submission requirements may change. You are as well encouraged to contact us for a follow-up meeting if the plan/concept will be further refined.

Please do not hesitate to contact me if you have any questions.

Regards,

Laurel

Laurel McCreight MCIP, RPP

Planner

Development Review West

Urbaniste

Examen des demandes d'aménagement ouest

City of Ottawa | Ville d'Ottawa

☎ 613.580.2424 ext./poste 16587

ottawa.ca/planning / ottawa.ca/urbanisme

This e-mail originates from the City of Ottawa e-mail system. Any distribution, use or copying of this e-mail or the information it contains by other than the intended recipient(s) is unauthorized. Thank you.

Yasar Ayub

To: Yasar Ayub
Subject: FW: 1050 Klondike Kanata - Confirmation for Extent of Services on Klondike Road.

Hi Yasar,

Pardon the delay. As we discussed over the phone last month, the applicant can service 1050 Klondike from either Sandhill Rd (Option 2) or Klondike Road for sanitary and water, however Option 1 is not a preferred approach. Since the proposal is no longer a low-rise building, but now townhouses, services for each townhouse can be provided from either the proposed laneway or from Klondike Rd directly. The City's preference would be to service the townhouses from Klondike Road as this would extend the City infrastructure and reduces the shared maintenance costs of the townhouses for the shared private infrastructure through the rear private lane.

I also mentioned that there is a proposed development at 1055 Klondike that is proposing to extend the sanitary and water infrastructure along Klondike Road, however I am currently unsure of their timelines. Please take a look on the City of Ottawa Development Applications Search Tool ([link](#)) to find the latest plans produced by the nearby 1055 Klondike Rd under development application D07-16-19-0024 to see how they have approached the Klondike Road sewer and watermain extensions. Perhaps you can reach out to the developer of 1055 Klondike to coordinate works.

Please let me know if you have further questions.

Regards,
Gabrielle (Gabi) Schaeffer, P.Eng
Senior Engineer - Infrastructure Applications

City of Ottawa
Development Review - West Branch
Planning, Infrastructure and Economic Development Department
110 Laurier Ave., 4th Floor East;
Ottawa ON K1P 1J1
Mail Code 01-14
Tel: 613-580-2424 x 22517
Cell: 613-227-7419
Fax: 613-560-6006

****During this period of uncertainty surrounding COVID-19, we are following recommended best practices to minimize the risk of exposure, while ensuring service to our clients remains as uninterrupted as possible. I am working from home, and my work hours may be affected, but I will respond to emails at my earliest opportunity. Should there be delays, I thank you for your understanding and patience.****

From: Yasar Ayub <yayub@jainconsultants.com>
Sent: March 16, 2021 12:58 PM
To: Deborah Belfie <belfied@rogers.com>; Schaeffer, Gabrielle <gabrielle.schaeffer@Ottawa.ca>
Cc: Junaid Israr <jjsrar@gmail.com>; israr akhtar <israrakhtar@hotmail.com>
Subject: RE: 1050 Klondike Kanata - Confirmation for Extent of Services on Klondike Road.

CAUTION: This email originated from an External Sender. Please do not click links or open attachments unless you recognize the source.

ATTENTION : Ce courriel provient d'un expéditeur externe. Ne cliquez sur aucun lien et n'ouvrez pas de pièce jointe, excepté si vous connaissez l'expéditeur.

On Wednesday, February 24, 2021, 11:15:56 a.m. EST, Yasar Ayub <yayub@jainconsultants.com> wrote:

Hi Gabrielle,

Just checking to see if you were able to consult with other city staff and give your feedback on the servicing arrangement for the revised proposal. We will then need to discuss with our client and proceed with one of the three options.

Yasar

416.668.6367

From: Yasar Ayub
Sent: February 18, 2021 1:18 PM
To: Schaeffer, Gabrielle <gabrielle.schaeffer@Ottawa.ca>
Cc: Deborah Belfie <belfied@rogers.com>; Junaid Israr <jisrar@gmail.com>; israr akhtar <israrakhtar@hotmail.com>
Subject: RE: 1050 Klondike Kanata - Confirmation for Extent of Services on Klondike Road.

Hi Gabrielle,

We would like to request a review of the proposed sanitary connection arrangement for the revised building footprint (row townhouses instead of apartments).

Option 1- As per the pre consultation comments, we were supposed to run a small section of sanitary sewer on Klondike and connect to the existing sanitary manhole at the Klondike/ Sandhill intersection. This arrangement would involve removal of several trees on the south west corner. A gas main will also need to be crossed and the sanitary sewer on Klondike will be a short section. This option is shown as a solid line on Drawing C101.

Option 2- To go east through the laneway on to Sandhill Rd and run a sanitary sewer on Sandhill Rd to the existing sanitary manhole at the Klondike/ Sandhill intersection. This would avoid damaging the trees and involve less conflicts with existing services. This option is shown as a dashed line on Drawing C101.

Please have a look and we can always discuss it further through email or an online meeting. It would help us to avoid any abortive work later and make a coordinated submission for the sanitary servicing.

Regards,

Yasar

416.668.6367

Yasar Ayub, P.Eng., PMP

Jain Infrastructure Consultants Ltd.

7405 East Danbro Crescent, 2nd Floor

Mississauga, ON L5N 6P8

Tel: (905) 285-9900 X 225

Fax: (905) 567-5246

Cell:(416) 668 6367

www.jainconsultants.com

 Please consider the environment before printing this email

From: Schaeffer, Gabrielle <gabrielle.schaeffer@Ottawa.ca>

Sent: October 6, 2020 12:29 PM

To: Yasar Ayub <yayub@jainconsultants.com>

Cc: Deborah Belfie <belfied@rogers.com>; Junaid Israr <jisrar@gmail.com>; israr akhtar <israrakhtar@hotmail.com>

Subject: RE: 1050 Klondike Kanata - Confirmation for Extent of Services on Klondike Road.

Hi Yasar,

I have attached two screenshots of the GeoOttawa site for City staff. There is one for the public, but with limited information. You will see that the infrastructure between March and Sandhill was not constructed. The second attachment provides the exist SAN MH invert information we have on record, however it is the proponent's responsibility to verify the elevations on-site. We cannot guarantee this information is correct if there are any discrepancies found.

Hope this helps,

Gabrielle

From: Yasar Ayub <yayub@jainconsultants.com>

Sent: October 06, 2020 9:57 AM

To: Schaeffer, Gabrielle <gabrielle.schaeffer@Ottawa.ca>

Cc: Deborah Belfie <belfied@rogers.com>; Junaid Israr <jisrar@gmail.com>; israr akhtar <israrakhtar@hotmail.com>

Subject: RE: 1050 Klondike Kanata - Confirmation for Extent of Services on Klondike Road.

CAUTION: This email originated from an External Sender. Please do not click links or open attachments unless you recognize the source.

ATTENTION : Ce courriel provient d'un expéditeur externe. Ne cliquez sur aucun lien et n'ouvrez pas de pièce jointe, excepté si vous connaissez l'expéditeur.

Please confirm if you have received my email. We would like to request your advise so that we can proceed with the SPA design.

Yasar

416.668.6367

From: Yasar Ayub
Sent: September 30, 2020 3:29 PM
To: gabrielle.schaeffer@ottawa.ca
Cc: Deborah Belfie <belfied@rogers.com>; Junaid Israr <jisrar@gmail.com>; israr akhtar <israrakhtar@hotmail.com>
Subject: 1050 Klondike Kanata - Confirmation for Extent of Services on Klondike Road.

Hi Gabrielle,

We would like to seek clarification on the extent of services constructed on Klondike Road west of the sandhill street intersection.

The attached the engineering plans acquired from the City; Plans 14070-19& 20 (As built drawings prepared by NovaTech in November 2013) show these services .

We would like to check the city record as we need to extend the sanitary sewer 20m west of Sandhill Street intersection.

Yasar

416.668.6367

Yasar Ayub, P.Eng., PMP

Jain Infrastructure Consultants Ltd.

7405 East Danbro Crescent, 2nd Floor

Mississauga, ON L5N 6P8

Tel: (905) 285-9900 X 225

Fax: (905) 567-5246

Cell:(416) 668 6367

www.jainconsultants.com

 *Please consider the environment before printing this email*

'

This e-mail originates from the City of Ottawa e-mail system. Any distribution, use or copying of this e-mail or the information it contains by other than the intended recipient(s) is unauthorized. Thank you.

Le présent courriel a été expédié par le système de courriels de la Ville d'Ottawa. Toute distribution, utilisation ou reproduction du courriel ou des renseignements qui s'y trouvent par une personne autre que son destinataire prévu est interdite. Je vous remercie de votre collaboration.

'

This e-mail originates from the City of Ottawa e-mail system. Any distribution, use or copying of this e-mail or the information it contains by other than the intended recipient(s) is unauthorized. Thank you.

Le présent courriel a été expédié par le système de courriels de la Ville d'Ottawa. Toute distribution, utilisation ou reproduction du courriel ou des renseignements qui s'y trouvent par une personne autre que son destinataire prévu est interdite. Je vous remercie de votre collaboration.

Appendix C
Water Demand and FUS Calculations
DR03 Fire Hydrant Coverage Map

Boundary Conditions 1050 Klondike Road

Provided Information

Scenario	Demand	
	L/min	L/s
Average Daily Demand	6	0.097
Maximum Daily Demand	55	0.92
Peak Hour	83	1.39
Fire Flow Demand #1	13,000	216.67

Location

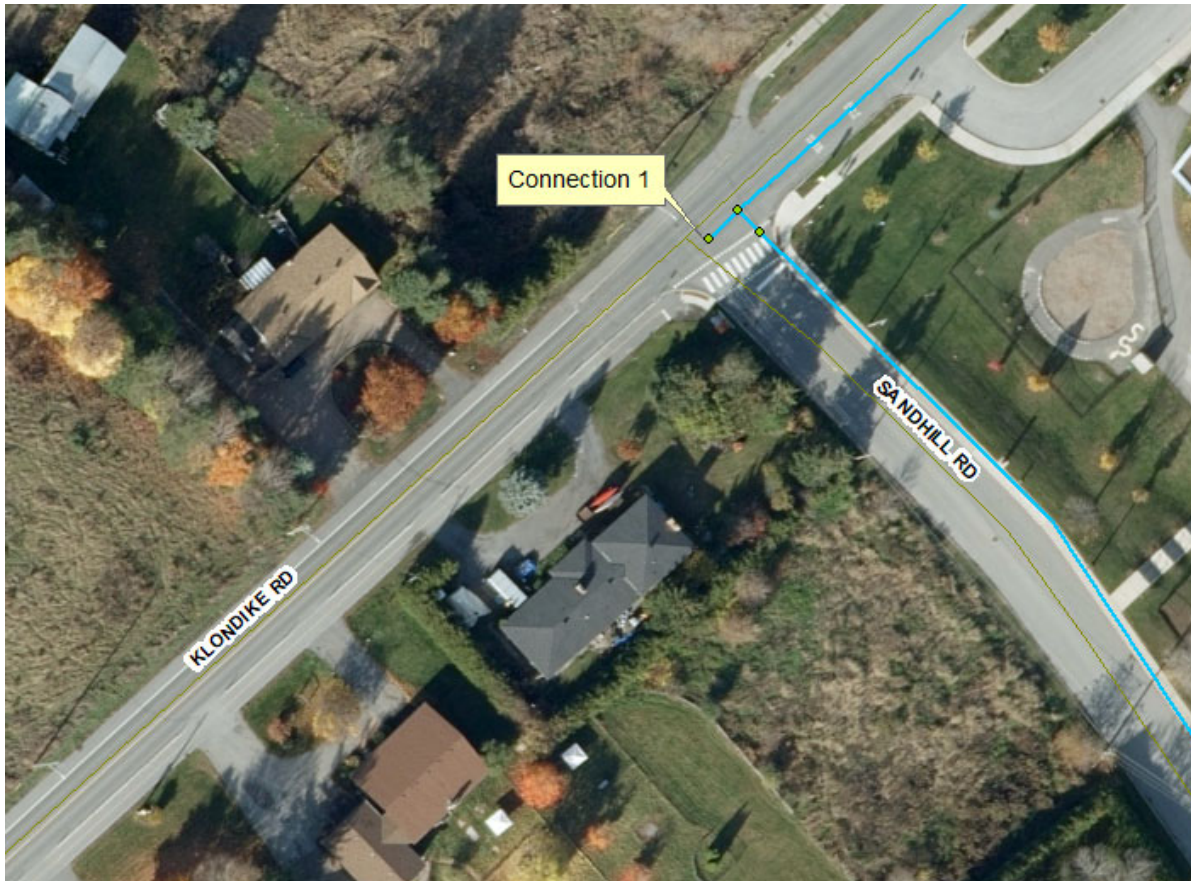

Results

Connection 1 – Klondike Rd.

Demand Scenario	Head (m)	Pressure ¹ (psi)
Maximum HGL	130.0	78.3
Peak Hour	126.3	73.1
Max Day plus Fire 1	121.2	65.8

Ground Elevation = 74.9 m

Disclaimer

The boundary condition information is based on current operation of the city water distribution system. The computer model simulation is based on the best information available at the time. The operation of the water distribution system can change on a regular basis, resulting in a variation in boundary conditions. The physical properties of watermains deteriorate over time, as such must be assumed in the absence of actual field test data. The variation in physical watermain properties can therefore alter the results of the computer model simulation. Fire Flow analysis is a reflection of available flow in the watermain; there may be additional restrictions that occur between the watermain and the hydrant that the model cannot take into account.

Table C1

**FIRE FLOW CALCULATION as per
FIRE UNDERWRITERS SURVEY (1999)**

Date: 19-May-21
Designer: UA
Checked By: YA

PROJECT: 1050 Klondike Road
 Ottawa, ON

1. Fire Flow Equation

$$F = 220 C \sqrt{A}$$

where F is the required fire flow [LPM]
 C is the coefficient determined by type of construction [unitless]
 A is the total protection area [sq.m]

2. Architecture Information (To be confirmed)

Type of Construction	Combustible	
Fire Rating	Wood Frame	
Sprinkler Provided (Y/N)	N	
Total Floor Area [sq.m]	1511	3 - Storeys
Coefficient, C [1]	1.5	Wood Frame
Fire Flow, F [LPM]	12828	

3. Occupancy Reduction

Occupancy Adjustment	0.85	- 15 % reduction for residential building
Fire Flow, F [LPM]	10903	

4. Sprinkler Reduction

Sprinkler Reduction	0.00	No sprinkler system
Sprinkler Reduction [LPM]	0	

5. Exposure Adjustment

North	0.05	44 m
East	0.00	75 m
South	0.00	85 m
West	0.15	13 m
Total	0.20	
Exposure Adjustment [LPM]	2181	

See attachment for off set distance

6. Required Fire Flow, Duration & Volume

Fire Flow, F [LPM]	10903	
Sprinkler Reduction [LPM]	0	
Exposure Adjustment [LPM]	2181	
Required Fire Flow [LPM]	13084	
Required Fire Flow [LPM]	13000	Round to nearest 1000
Required Fire Flow [LPS]	217	
Req. Duration of Fire Flow [hrs]	2	
Req. Storage [cubic.m]	1560	

USMAN ARIF

From: Armstrong, Justin <justin.armstrong@ottawa.ca>
Sent: November-12-21 9:27 AM
To: Yasar Ayub
Cc: USMAN ARIF; Dieme, Abi
Subject: RE: 1050 Klondike Kanata - Boundary Conditions Request
Attachments: Tech bulletin ISTB-2018-02.pdf

Hi Yasar,

Ahmed Elsayed is no longer with the City, and Abi Dieme has taken over this file. I am including Abi in this e-mail so that she can help with questions you may have as it relates to the City engineering comments previously provided.

Note that from Google Streetview, it seems the hydrant in question is a AA rated hydrant, which means it can be considered to contribute 5,700 L/min of fire flow if it is within 75 meters of the site, and can be considered to contribute 3,800 L/min of fire flow if it is between 75 meters and 150 meters from the site. This is as per City Water Design Guidelines Technical Bulletin Document ISTB-2018-02, Appendix I (attached for your reference).

Regards,

Justin

Justin Armstrong, E.I.T.

Project Manager

Planning, Infrastructure and Economic Development Department - Services de la planification, de l'infrastructure et du développement économique

Development Review - West Branch

City of Ottawa | Ville d'Ottawa

110 Laurier Avenue West Ottawa, ON | 110, avenue. Laurier Ouest. Ottawa (Ontario) K1P 1J1

613.580.2424 ext./poste 21746, justin.armstrong@ottawa.ca

From: Yasar Ayub <yayub@jainconsultants.com>
Sent: November 10, 2021 6:26 PM
To: Armstrong, Justin <justin.armstrong@ottawa.ca>
Cc: USMAN ARIF <uarif@jainconsultants.com>; Elsayed, Ahmed <ahmed.elsayed@ottawa.ca>
Subject: RE: 1050 Klondike Kanata - Boundary Conditions Request

Hi John,

Can we get the flow available at the hydrant located at the corner of sandhill and klondike road. We need this info to address one of the city comments.

Yasar
416.668.6367

Yasar Ayub

From: Yasar Ayub
Sent: May 4, 2021 5:02 PM
To: Armstrong, Justin
Cc: USMAN ARIF
Subject: RE: 1050 Klondike Kanata - Boundary Conditions Request
Attachments: Drinking Water Boundary condition request - 04-05-2021.pdf; Map - off set Distance.pdf; FUS Cal.pdf

Hi Justin,

The revised FUS calculations are attached as per the Ottawa FUS procedure.
Please review and forward accordingly.

Yasar Ayub, P.Eng., PMP
Jain Infrastructure Consultants Ltd.
7405 East Danbro Crescent, 2nd Floor
Mississauga, ON L5N 6P8
Tel: (905) 285-9900 X 225
Fax: (905) 567-5246
Cell:(416) 668 6367
www.jainconsultants.com

 Please consider the environment before printing this email

From: Armstrong, Justin <justin.armstrong@ottawa.ca>
Sent: May 4, 2021 1:09 PM
To: Yasar Ayub <yayub@jainconsultants.com>
Subject: FW: 1050 Klondike Kanata - Boundary Conditions Request

Hi Yasar,

As Ahmed is out of the office for the next little while, I will be helping out with this boundary request. Our boundary conditions group has flagged some concerns with the required fire flow and I am wondering if you can help clarify. Without having much knowledge about this project, the required fire flow of 3000 L/min seems rather low.

In your e-mail below you identify that the development proposal has been revised from condominium apartment buildings to freehold townhouses. In the attached FUS calculation sheet, the gross (total) floor area for the townhouse block is identified as 159 sq.m. This seems small for the gross floor area of a townhouse block. The area that should be used in the FUS method should be the gross floor area of the entire townhouse block (i.e. townhouse block footprint * number of floors).

You have used a construction class coefficient (C) of 0.8 which reflects non-combustible construction. Typically, townhouses are wood-frame which would correspond to a construction class coefficient (C) of 1.5 (typical wood frame construction) or 1.0 (a construction class of *ordinary construction (1.0)* can be used for wood frame construction if the exterior walls are masonry or non-combustible). Please confirm construction class for the townhouse block.

For residential buildings, an occupancy charge of -15% should be used.

For the exposure section of the attached FUS calculation sheet, please provide the offset distance of the townhouse block to the nearest structure for each of the north, east, south, and west exposures. A site plan showing the proposed location of the townhouse block on the property and its offset distance to any adjacent building is very helpful here.

Also, for your info, the City of Ottawa's Water Distribution Guidelines Technical Bulletin ISTB-2018-02 provides a very detailed description of the FUS method and how it should be followed for City of Ottawa applications.

Regards,

During this period of uncertainty surrounding COVID-19, we are following best practices recommended to minimize the risk of exposure, while ensuring that service to our clients remains as uninterrupted as possible. For the most part I am working from home and will respond to emails at my earliest opportunity. Should there be delays due to internet connectivity, I thank your understanding and patience.

Justin Armstrong, E.I.T.

Project Manager

Planning, Infrastructure and Economic Development Department - Services de la planification, de l'infrastructure et du développement économique

Development Review - West Branch

City of Ottawa | Ville d'Ottawa

110 Laurier Avenue West Ottawa, ON | 110, avenue. Laurier Ouest. Ottawa (Ontario) K1P 1J1

613.580.2424 ext./poste 21746, justin.armstrong@ottawa.ca

From: Yasar Ayub <yayub@jainconsultants.com>

Sent: Monday, May 3, 2021 5:09 PM

To: Elsayed, Ahmed <ahmed.elsayed@ottawa.ca>

Cc: USMAN ARIF <uarif@jainconsultants.com>

Subject: RE: 1050 Klondike Kanata - Boundary Conditions Request

CAUTION: This email originated from an External Sender. Please do not click links or open attachments unless you recognize the source.

ATTENTION : Ce courriel provient d'un expéditeur externe. Ne cliquez sur aucun lien et n'ouvrez pas de pièce jointe, excepté si vous connaissez l'expéditeur.

The development proposal was revised and freehold townhouses are being proposed instead of the condominium apartment building.

The revised water demand and FUS calculations are attached. Requesting a review of the boundary conditions provided previously .

Regards,

Yasar

416.668.6367

From: Yasar Ayub

Sent: November 6, 2020 11:54 AM

To: Elsayed, Ahmed <ahmed.elsayed@ottawa.ca>
Subject: RE: 1050 Klondike Kanata - Boundary Conditions Request

Thanks Ahmed.

From: Elsayed, Ahmed <ahmed.elsayed@ottawa.ca>
Sent: November 6, 2020 11:12 AM
To: Yasar Ayub <yayub@jainconsultants.com>
Subject: FW: 1050 Klondike Kanata - Boundary Conditions Request

Hi Yasar,

Attached is the BC as requested.

Thanks,
Ahmed

From: Yasar Ayub <yayub@jainconsultants.com>
Sent: October 26, 2020 4:29 PM
To: Elsayed, Ahmed <ahmed.elsayed@ottawa.ca>
Cc: Schaeffer, Gabrielle <gabrielle.schaeffer@Ottawa.ca>
Subject: RE: 1050 Klondike Kanata - Boundary Conditions Request

CAUTION: This email originated from an External Sender. Please do not click links or open attachments unless you recognize the source.

ATTENTION : Ce courriel provient d'un expéditeur externe. Ne cliquez sur aucun lien et n'ouvrez pas de pièce jointe, excepté si vous connaissez l'expéditeur.

The revised request documents with 100% floor area taken for FUS calculations is attached.

Yasar

From: Yasar Ayub
Sent: October 26, 2020 3:53 PM
To: 'Elsayed, Ahmed' <ahmed.elsayed@ottawa.ca>
Cc: 'Schaeffer, Gabrielle' <gabrielle.schaeffer@Ottawa.ca>
Subject: RE: 1050 Klondike Kanata - Boundary Conditions Request

Hi Ahmed,

Find attached all the documents.

Yasar
416.668.6367

From: Yasar Ayub
Sent: October 26, 2020 1:28 PM
To: 'Elsayed, Ahmed' <ahmed.elsayed@ottawa.ca>

Cc: Schaeffer, Gabrielle <gabrielle.schaeffer@Ottawa.ca>
Subject: RE: 1050 Klondike Kanata - Boundary Conditions Request

Hi Ahmed,

I sent the following yesterday. Please have a look if it provides this info and call me on cell to discuss further.

Yasar
416.668.6367

From: Elsayed, Ahmed <ahmed.elsayed@ottawa.ca>
Sent: October 26, 2020 1:21 PM
To: Yasar Ayub <yayub@jainconsultants.com>
Cc: Schaeffer, Gabrielle <gabrielle.schaeffer@Ottawa.ca>
Subject: RE: 1050 Klondike Kanata - Boundary Conditions Request

Hi Yasar,

Please compile all the information in the same email, also please provide some description/information about the project.

- Water Boundary condition requests must include the location of the service and the expected loads required by the proposed development. Please provide the following information:
 1. Location map with water service connection location
 2. Average daily demand (l/s)
 3. Maximum daily demand (l/s)
 4. Maximum hourly demand (l/s)
 5. Fire flow demand (provide fire detailed flow calculations based on the fire underwriters survey method)

Regards,

Ahmed Elsayed, P. Eng.
Project Manager, Planning Services
Development Review West Branch
City of Ottawa | Ville d'Ottawa
Planning, Infrastructure and Economic Development Department
110 Laurier Avenue West. 4th Floor, Ottawa ON, K1P 1J1
[Tel:613.580.2424](tel:613.580.2424) ext. 21206
Fax: 613-580-2576

Please take note that due to current COVID situation, I am working remotely and Phone communication and messaging may not be reliable at this time. Preferred method of communications will be e-mails during this period. If your preference is telephone communication, please indicate this via e-mail and provide a contact telephone number.

I apologize for any inconvenience.

*Please consider your environmental responsibility before printing this e-mail

From: Yasar Ayub <yayub@jainconsultants.com>
Sent: October 26, 2020 1:13 PM
To: Elsayed, Ahmed <ahmed.elsayed@ottawa.ca>
Cc: Schaeffer, Gabrielle <gabrielle.schaeffer@Ottawa.ca>
Subject: RE: 1050 Klondike Kanata - Boundary Conditions Request

CAUTION: This email originated from an External Sender. Please do not click links or open attachments unless you recognize the source.

ATTENTION : Ce courriel provient d'un expéditeur externe. Ne cliquez sur aucun lien et n'ouvrez pas de pièce jointe, excepté si vous connaissez l'expéditeur.

The FUS calculations are attached.

Yasar

From: Elsayed, Ahmed <ahmed.elsayed@ottawa.ca>
Sent: October 26, 2020 1:04 PM
To: Yasar Ayub <yayub@jainconsultants.com>
Cc: Schaeffer, Gabrielle <gabrielle.schaeffer@Ottawa.ca>
Subject: FW: 1050 Klondike Kanata - Boundary Conditions Request

Hi Yasar,

Can you please provide your calculations for the fire flow demand?

After providing the information needed, it usually takes 10 business days to receive a feed back from IPU about the BC.

If you have any more questions, please let me know.

Thanks,
Ahmed

From: Schaeffer, Gabrielle <gabrielle.schaeffer@Ottawa.ca>
Sent: October 26, 2020 11:33 AM
To: Elsayed, Ahmed <ahmed.elsayed@ottawa.ca>
Subject: FW: 1050 Klondike Kanata - Boundary Conditions Request

Hi Ahmed,

Please review and coordinate this boundary conditions request. Please let Yasar know the BC timeline.

Thanks,

Gabi

From: Yasar Ayub <yayub@jainconsultants.com>
Sent: October 26, 2020 11:12 AM
To: Schaeffer, Gabrielle <gabrielle.schaeffer@Ottawa.ca>
Cc: Deborah Belfie <belfied@rogers.com>; Junaid Israr <jisrar@gmail.com>; israr akhtar <israrakhtar@hotmail.com>
Subject: RE: 1050 Klondike Kanata - Boundary Conditions Request

CAUTION: This email originated from an External Sender. Please do not click links or open attachments unless you recognize the source.

ATTENTION : Ce courriel provient d'un expéditeur externe. Ne cliquez sur aucun lien et n'ouvrez pas de pièce jointe, excepté si vous connaissez l'expéditeur.

The request for water boundary conditions is attached. Pl review and let us know the turnaround time for this request.

Yasar Ayub, P.Eng., PMP
Jain Infrastructure Consultants Ltd.
7405 East Danbro Crescent, 2nd Floor
Mississauga, ON L5N 6P8
Tel: (905) 285-9900 X 225
Fax: (905) 567-5246
Cell:(416) 668 6367
www.jainconsultants.com

 *Please consider the environment before printing this email*

From: Schaeffer, Gabrielle <gabrielle.schaeffer@Ottawa.ca>
Sent: October 6, 2020 12:29 PM
To: Yasar Ayub <yayub@jainconsultants.com>
Cc: Deborah Belfie <belfied@rogers.com>; Junaid Israr <jisrar@gmail.com>; israr akhtar <israrakhtar@hotmail.com>
Subject: RE: 1050 Klondike Kanata - Confirmation for Extent of Services on Klondike Road.

Hi Yasar,

I have attached two screenshots of the GeoOttawa site for City staff. There is one for the public, but with limited information. You will see that the infrastructure between March and Sandhill was not constructed. The second attachment provides the exist SAN MH invert information we have on record, however it is the proponent's responsibility to verify the elevations on-site. We cannot guarantee this information is correct if there are any discrepancies found.

Hope this helps,
Gabrielle

From: Yasar Ayub <yayub@jainconsultants.com>
Sent: October 06, 2020 9:57 AM
To: Schaeffer, Gabrielle <gabrielle.schaeffer@Ottawa.ca>
Cc: Deborah Belfie <belfied@rogers.com>; Junaid Israr <jisrar@gmail.com>; israr akhtar <israrakhtar@hotmail.com>
Subject: RE: 1050 Klondike Kanata - Confirmation for Extent of Services on Klondike Road.

CAUTION: This email originated from an External Sender. Please do not click links or open attachments unless you recognize the source.

ATTENTION : Ce courriel provient d'un expéditeur externe. Ne cliquez sur aucun lien et n'ouvrez pas de pièce jointe, excepté si vous connaissez l'expéditeur.

Please confirm if you have received my email. We would like to request your advise so that we can proceed with the SPA design.

Yasar
416.668.6367

From: Yasar Ayub
Sent: September 30, 2020 3:29 PM
To: gabrielle.schaeffer@ottawa.ca
Cc: Deborah Belfie <belfied@rogers.com>; Junaid Israr <jisrar@gmail.com>; israr akhtar <israrakhtar@hotmail.com>
Subject: 1050 Klondike Kanata - Confirmation for Extent of Services on Klondike Road.

Hi Gabrielle,

We would like to seek clarification on the extent of services constructed on Klondike Road west of the sandhill street intersection.

The attached the engineering plans acquired from the City; Plans 14070-19& 20 (As built drawings prepared by NovaTech in November 2013) show these services .

We would like to check the city record as we need to extend the sanitary sewer 20m west of Sandhill Street intersection.

Yasar
416.668.6367

Yasar Ayub, P.Eng., PMP
Jain Infrastructure Consultants Ltd.
7405 East Danbro Crescent, 2nd Floor
Mississauga, ON L5N 6P8
Tel: (905) 285-9900 X 225
Fax: (905) 567-5246
Cell:(416) 668 6367
www.jainconsultants.com

 *Please consider the environment before printing this email*

This e-mail originates from the City of Ottawa e-mail system. Any distribution, use or copying of this e-mail or the information it contains by other than the intended recipient(s) is unauthorized. Thank you.

Le présent courriel a été expédié par le système de courriels de la Ville d'Ottawa. Toute distribution, utilisation ou reproduction du courriel ou des renseignements qui s'y trouvent par une personne autre que son destinataire prévu est interdite. Je vous remercie de votre collaboration.

This e-mail originates from the City of Ottawa e-mail system. Any distribution, use or copying of this e-mail or the information it contains by other than the intended recipient(s) is unauthorized. Thank you.

Le présent courriel a été expédié par le système de courriels de la Ville d'Ottawa. Toute distribution, utilisation ou reproduction du courriel ou des renseignements qui s'y trouvent par une personne autre que son destinataire prévu est interdite. Je vous remercie de votre collaboration.

,

This e-mail originates from the City of Ottawa e-mail system. Any distribution, use or copying of this e-mail or the information it contains by other than the intended recipient(s) is unauthorized. Thank you.

Le présent courriel a été expédié par le système de courriels de la Ville d'Ottawa. Toute distribution, utilisation ou reproduction du courriel ou des renseignements qui s'y trouvent par une personne autre que son destinataire prévu est interdite. Je vous remercie de votre collaboration.

,

This e-mail originates from the City of Ottawa e-mail system. Any distribution, use or copying of this e-mail or the information it contains by other than the intended recipient(s) is unauthorized. Thank you.

Le présent courriel a été expédié par le système de courriels de la Ville d'Ottawa. Toute distribution, utilisation ou reproduction du courriel ou des renseignements qui s'y trouvent par une personne autre que son destinataire prévu est interdite. Je vous remercie de votre collaboration.

,

This e-mail originates from the City of Ottawa e-mail system. Any distribution, use or copying of this e-mail or the information it contains by other than the intended recipient(s) is unauthorized. Thank you.

Le présent courriel a été expédié par le système de courriels de la Ville d'Ottawa. Toute distribution, utilisation ou reproduction du courriel ou des renseignements qui s'y trouvent par une personne autre que son destinataire prévu est interdite. Je vous remercie de votre collaboration.

,

Please provide the boundary conditions for the proposed water service connection for the property at 1050 Klondike Drive.

a. Location of service (map/plan view)

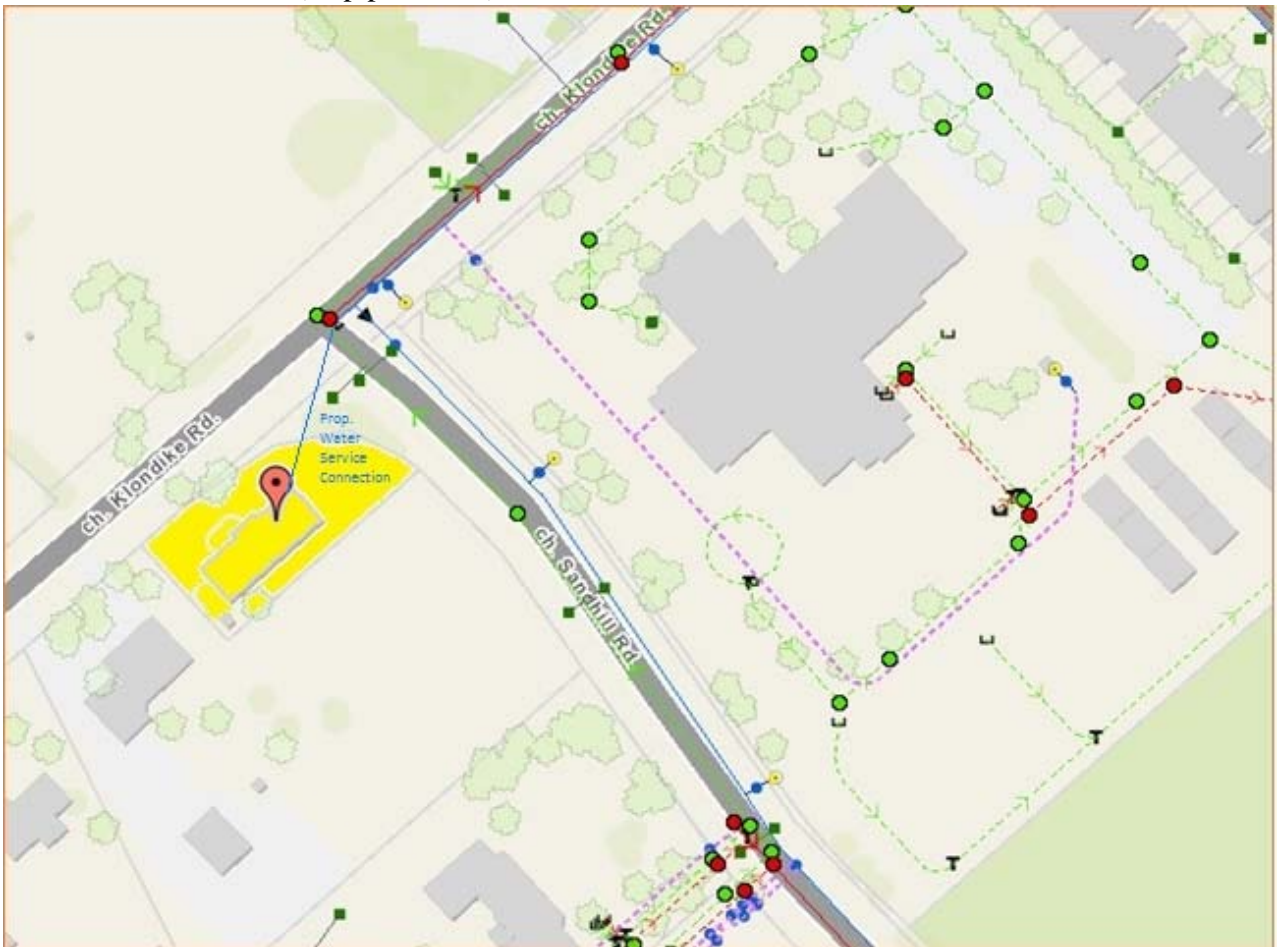

b. (Draft) site plan or similar plan for building location (Attached)

Design Parameter	Water Demand (L/s)
	Residential
Average Daily Demand	0.097
Maximum Daily Demand	0.92
Maximum Hourly Demand	1.39
Fire Flow	217.00
Total Max Daily Demand + Fire Flow	217.92

c. Supporting calculations for domestic demands

Total No. of Units = 9 units

Population = $2.7 \times 9 = 24$ persons

Daily Average Water Demand = $24 \times 350 \text{ l/cap/day} = 84,00 \text{ L/Day (0.097 L/sec)}$

Maximum Daily Demand = $0.097 \times 9.5 = 0.92 \text{ L/sec}$

Maximum Hourly Demand = $0.097 \times 14.3 = 1.39 \text{ L/sec}$



Appendix D
DR04 Sanitary Drainage Plan
Sanitary Flow Calculations
Sanitary Drainage Plan for Briar Ridge Pump station



TRUE NORTH

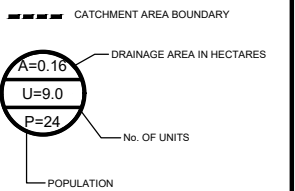
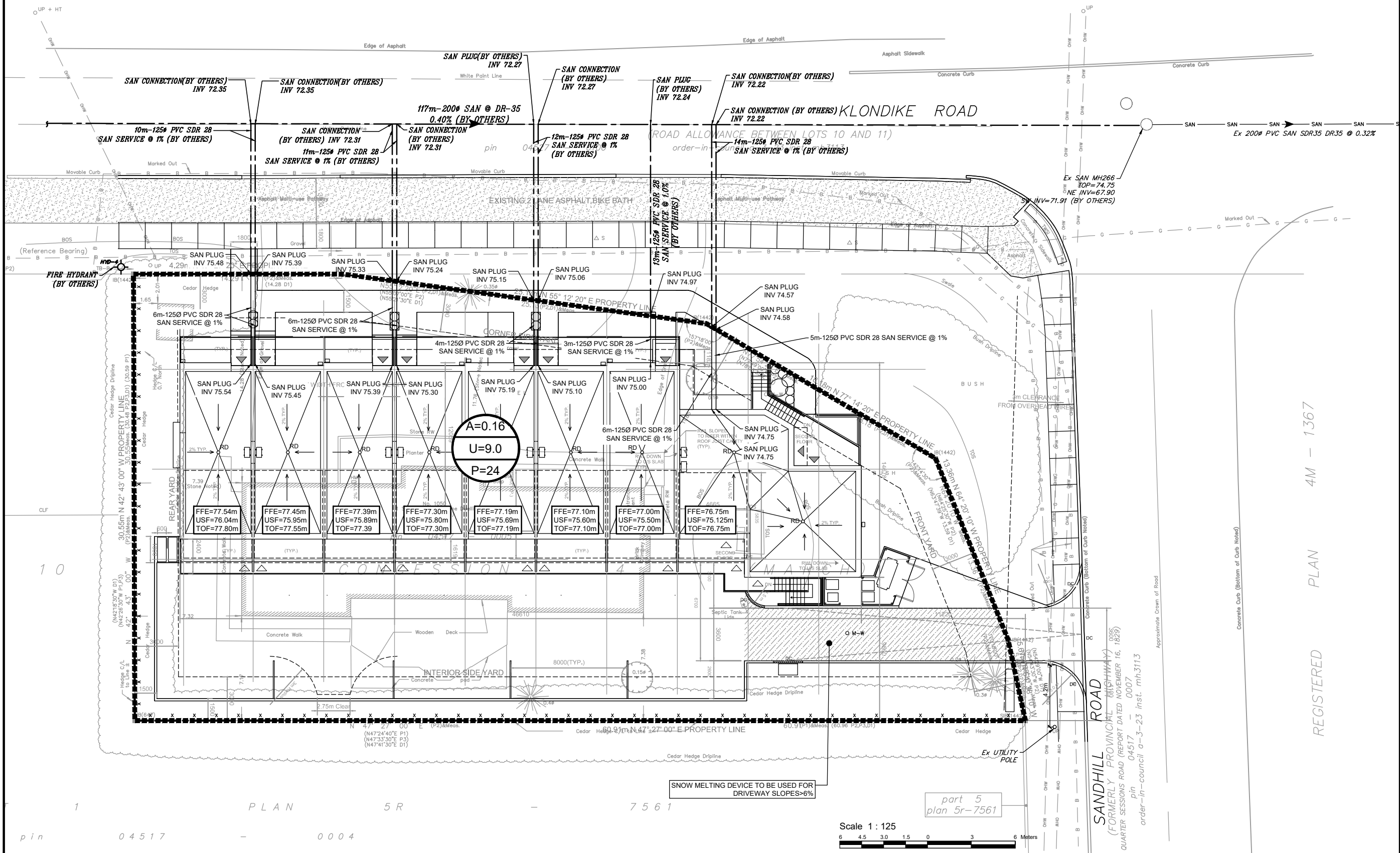
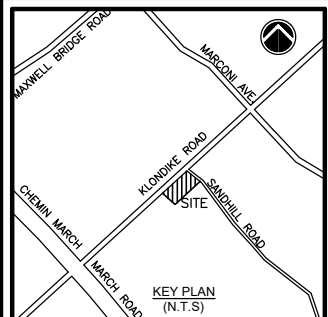

REVISION		
No.	DESCRIPTION	DATE
2	ISSUED FOR SPA	JUN 20 22
1	ISSUED FOR SPA	NOV 25 21

JAIN
 Jain Infrastructure Consultants Ltd.
 7405 EAST DANBRO CRESCENT
 MISSISSAUGA, ON L5N 6P8
 TEL: (905) 285-9900, FAX: (905) 567-5246
 Email: yayub@jainconsultants.com

PROJECT
1050 KLONDIKE ROAD
 OTTAWA, ONTARIO, K2K 1X7

DRAWING TITLE
SANITARY DRAINAGE PLAN

SCALE: 1:125
 DATE: Jun. 20, 22
 DRAWN BY: CC
 CHECKED BY: YA

DR04

REGISTERED PLAN 4M - 1367



part 5
plan 5r-7561

SNOW MELTING DEVICE TO BE USED FOR DRIVEWAY SLOPES > 6%

PLAN 5R

7561

pin 04517 - 0004

1050 Klondike Road - Post Development Sanitary Design Sheet

AREA			RESIDENTIAL													ICI					INFILTRATION			PIPE									
ID	From	To	Singles		Semi-Detached / Towns		1050 Klondike Rd			TOTAL			Light Industrial Area (ha)	Accum. Area (ha)	Peak Factor	Commercial Area (ha)	Institutional Area (ha)	Accum. Area (ha)	Peak Flow (l/s)	Total Area (ha)	Accum. Area (ha)	Infil. Flow (l/s)	Total Flow (l/s)	Size (mm)	Slope (%)	Length (m)	Capacity (l/s)	Full Flow Vel. (m/s)	α _{full} (%)				
			Units	Pop.	Units	Pop.	Future Block 10	Future 1075 Klondike	Pop.	No. OF Units @ 2.7 Persons	Pop.	Pop.																		Accum. Pop.	Peak Factor	Peak Flow (l/s)	
1055 Klondike Road Drainage Areas																																	
A1-1	7	5	0	0.0	15	40.5	0.00		0.0		0.0	40.5	40.5	3.7	0.5					0.00	0.00	0.00	0.0	0.64	0.64	0.2	0.7	200	0.65	19.9	27.6	0.85	2.5%
A1-2	5	3	0	0.0	29	78.3	0.00		0.0		0.0	78.3	118.8	3.6	1.4					0.00	0.00	0.00	0.0	0.80	1.44	0.5	1.9	200	0.50	100.0	24.2	0.75	7.7%
A1-3	3	1	0	0.0	14	37.8	0.00		0.0		0.0	37.8	156.6	3.5	1.8					0.00	0.00	0.00	0.0	0.41	1.85	0.6	2.4	200	0.50	62.3	24.2	0.75	10.0%
A2-1, A2-2	9	1	0	0.0	0	0.0	53	10	128.9		0.0	128.9	128.9	3.6	1.5					0.00	0.00	0.00	0.0	0.88	0.88	0.3	1.8	200	0.65	46.2	27.6	0.85	6.5%
	1	266	0	0.0	0	0.0	0.00		0.0		9	24.3	24.3	309.8	4.0	4.02				0.00	0.00	0.00	0.0	0.16	2.89	1.0	5.0	200	0.65	117.0	27.6	0.85	14.9%
Off-site Drainage Areas (To Briar Ridge Pump Station)																																	
A3-3	266	265	0	0.0	57	153.9	0.00		0.0		0.0	153.9	463.7	3.4	5.1					0.00	0.00	0.00	0.0	2.47	5.36	1.8	6.9	200	0.32	91.0	19.4	0.60	33.9%
A3-4	265	264	0	0.0	0	0.0	0.00		0.0		0.0	0.0	463.7	3.4	5.1					0.00	2.21	2.21	1.1	2.21	7.57	2.5	8.7	200	0.32	120.0	19.4	0.60	43.2%
A3-5	264	206	0	0.0	107	288.9	0.00		0.0		0.0	288.9	752.6	3.4	8.3					0.00	0.00	2.21	1.1	3.99	11.56	3.8	13.2	250	0.24	306.3	30.4	0.60	41.6%
A3-1, A3-2, A3-6	206	205	201	683.4	392	1058.4	0.00		0.0		0.0	1741.8	2494.4	3.0	24.3					9.02	0.00	11.23	5.5	37.33	48.89	16.1	45.9	450	0.20	52.5	133.0	0.81	34.3%
A3-7, A3-8	205	204	0	0.0	0	0.0	0.00		0.0		0.0	0.0	2494.4	3.0	24.3	5.4	5.4	4.7		0.00	0.00	11.23	15.7	5.40	54.29	17.9	67.9	450	0.20	79.7	133.0	0.81	43.4%
	204	203	0	0.0	0	0.0	0.00		0.0		0.0	0.0	2494.4	3.0	24.3	5.4	4.7		0.00	0.00	11.23	15.7	0.00	54.29	17.9	67.9	450	0.20	79.7	133.0	0.81	43.4%	
	203	202	0	0.0	0	0.0	0.00		0.0		0.0	0.0	2494.4	3.0	24.3	7.9	13.3	3.9		0.00	0.00	11.23	26.5	7.90	62.19	20.5	71.3	450	0.26	90.0	151.7	0.92	46.8%
	202	201	0	0.0	0	0.0	0.00		0.0		0.0	0.0	2494.4	3.0	24.3					0.00	0.00	11.23	26.5	0.00	62.19	20.5	71.3	450	0.25	270.0	148.7	0.91	47.8%
	201	PS	0	0.0	0	0.0	0.00		0.0		0.0	0.0	2494.4	3.0	24.3					0.00	0.00	11.23	26.5	0.00	62.19	20.5	71.3	450	0.15	21.6	115.2	0.70	61.7%
Design Parameters: Avg Flow/Person = 280 l/day Comm./Inst. Flow = 28000 l/ha/day Light Industrial Flow = 35000 l/ha/day Infiltration = 0.33 l/s/ha Pipe Friction n = 0.013 Residential Peaking Factor = Harmon Equation (max 4, min 2) Peaking Factor Comm./Inst. 1.5																																	
Population Density: units/ha pp/unit Future Block 10 Apartment Unit 2.1 Future 1075 Klondike Road 1.8 35 Single 3.4 Semi / Town 2.7																																	
Project: 1050 Klondike Road Designed: UA Checked: YA Date: May 20,2021																																	
Jain Infrastructure Consultants Ltd																																	
Shaded Cells show revised numbers as per 1050 Klondike Rd Flows																																	

1055 Klondike Road - Orr Ridge: Sanitary Sewer Design Sheet

AREA			RESIDENTIAL											ICI				INFILTRATION			PIPE									
ID	From	To	Singles		Semi-Detached / Towns		TOTAL				Light Industrial Area (ha)	Accum. Area (ha)	Peak Factor	Commercial Area (ha)	Institutional Area (ha)	Accum. Area (ha)	Peak Flow (l/s)	Total Area (ha)	Accum. Area (ha)	Infil. Flow (l/s)	Total Flow (l/s)	Size (mm)	Slope (%)	Length (m)	Capacity (l/s)	Full Flow Vel. (m/s)	Q/Q _{full} (%)			
			Units	Pop.	Units	Pop.	Future Block 10	Future 1075 Klondike Rd	Pop.	Pop.																		Accum. Pop.	Peak Factor	Peak Flow (l/s)
1055 Klondike Road Drainage Areas																														
A1-1	7	5	0	0.0	15	40.5	0.00		0.0	40.5	40.5	3.7	0.5		0.00	0.00	0.00	0.0	0.64	0.64	0.2	0.7	200	0.65	19.9	27.6	0.85	2.5%		
A1-2	5	3	0	0.0	29	78.3	0.00		0.0	78.3	118.8	3.6	1.4		0.00	0.00	0.00	0.0	0.80	1.44	0.5	1.9	200	0.50	100.0	24.2	0.75	7.7%		
A1-3	3	1	0	0.0	14	37.8	0.00		0.0	37.8	156.6	3.5	1.8		0.00	0.00	0.00	0.0	0.41	1.85	0.6	2.4	200	0.50	62.3	24.2	0.75	10.0%		
A2-1, A2-2	9	1	0	0.0	0	0.0	53	10	128.9	128.9	128.9	3.6	1.5		0.00	0.00	0.00	0.0	0.88	0.88	0.3	1.8	200	0.65	46.2	27.6	0.85	6.5%		
	1	266	0	0.0	0	0.0	0.00		0.0	0.0	285.5	3.5	3.2		0.00	0.00	0.00	0.0	0.00	2.73	0.9	4.1	200	0.65	117.0	27.6	0.85	14.9%		
Off-site Drainage Areas (To Briar Ridge Pump Station)																														
A3-3	266	265	0	0.0	57	153.9	0.00		0.0	153.9	439.4	3.4	4.8		0.00	0.00	0.00	0.0	2.47	5.20	1.7	6.6	200	0.32	91.0	19.4	0.60	33.9%		
A3-4	265	264	0	0.0	0	0.0	0.00		0.0	0.0	439.4	3.4	4.8		0.00	2.21	2.21	1.1	2.21	7.41	2.4	8.4	200	0.32	120.0	19.4	0.60	43.2%		
A3-5	264	206	0	0.0	107	288.9	0.00		0.0	288.9	728.3	3.3	7.8		0.00	0.00	2.21	1.1	3.99	11.40	3.8	12.6	250	0.24	306.3	30.4	0.60	41.6%		
A3-1, A3-2, A3-6	206	205	201	683.4	392	1058.4	0.00		0.0	1741.8	2470.1	3.0	24.1		9.02	0.00	11.23	5.5	37.33	48.73	16.1	45.6	450	0.20	52.5	133.0	0.81	34.3%		
A3-7, A3-8	205	204	0	0.0	0	0.0	0.00		0.0	0.0	2470.1	3.0	24.1	5.4	5.4	4.7	0.00	0.00	11.23	15.7	5.40	54.13	17.9	57.7	450	0.20	79.7	133.0	0.81	43.4%
	204	203	0	0.0	0	0.0	0.00		0.0	0.0	2470.1	3.0	24.1		5.4	4.7	0.00	0.00	11.23	15.7	0.00	54.13	17.9	57.7	450	0.20	79.7	133.0	0.81	43.4%
	203	202	0	0.0	0	0.0	0.00		0.0	0.0	2470.1	3.0	24.1	7.9	13.3	3.9	0.00	0.00	11.23	26.5	7.90	62.03	20.5	71.0	450	0.26	90.0	151.7	0.92	46.8%
	202	201	0	0.0	0	0.0	0.00		0.0	0.0	2470.1	3.0	24.1		13.3	3.9	0.00	0.00	11.23	26.5	0.00	62.03	20.5	71.0	450	0.25	270.0	148.7	0.91	47.8%
	201	PS	0	0.0	0	0.0	0.00		0.0	0.0	2470.1	3.0	24.1		13.3	3.9	0.00	0.00	11.23	26.5	0.00	62.03	20.5	71.0	450	0.15	21.6	115.2	0.70	61.7%

Design Parameters:
 Avg Flow/Person = 280 l/day
 Comm./Inst. Flow = 28000 l/ha/day
 Light Industrial Flow = 35000 l/ha/day
 Infiltration = 0.33 l/s/ha
 Pipe Friction n = 0.013
 Residential Peaking Factor = Harmon Equation (max 4, min 2)
 Peaking Factor Comm./Inst. 1.5

Population Density:
 ppl/unit units/ha
 Future Block 10 Apartment Unit 2.1
 Future 1075 Klondike Road 1.8 35
 Single 3.4
 Semi / Town 2.7

Project: 1055 Klondike Road - Orr Ridge (117034)
 Designed: LRW
 Checked: MAB
 Date: February 18, 2021



Appendix E
Storm Sewer Design Calculations
Vortex Flow Control Device
SWM Catchments for Brookside Subdivision & Pond "C"
Stormceptor Sizing Calculations
Storm Tank Module

TABLE E1. Land use Breakdown and Composite Runoff Coefficients Calculations Existing Conditions

Project: 1050 Klondike Drive, Ottawa, ON

Date: 20-Jun-22

Designed By: UA

Checked By: YA

TABLE E1.1 AREA A1

Existing Land Use Cover	A, Area (hectares)	R, Runoff Coefficient	A x R
Bldg/ Roof	0.024	0.90	0.02
Concrete	0.011	0.90	0.01
Gravel	0.017	0.80	0.013
Landscape	0.074	0.25	0.02
Overall	0.126	0.50	0.06

TABLE E1.2 AREA A2

Existing Land Use/ Cover	A, Area (hectares)	R, Runoff Coefficient	A x R
Building	0.001	0.90	0.00
Gravel	0.009	0.80	0.01
Landscape	0.022	0.25	0.01
Overall	0.031	0.42	0.013

Note: As per pre consultation comments, Pre development runoff coefficient "R" is recommended as a maximum equivalent of "0.5". However as per Brookside Subdivision Storm Drainage Area Plan, R is considered as "0.45" and same has been adopted for current design

**TABLE E2. Land use Breakdown and Composite Runoff Coefficients Calculations
Proposed Conditions**

Project: 1050 Klondike Drive, Ottawa, ON

Date: 20-Jun-22

Designed By: UA

Checked By: YA

TABLE E2.1 AREA A1

Proposed Land Use/ Cover	A, Area (hectares)	R, Runoff Coefficient	A x R
Bldg/ Roof	0.052	0.90	0.047
Concrete/Asphalt	0.053	0.90	0.047
Landscape	0.021	0.25	0.005
Overall	0.126	0.79	0.100

TABLE E2.2 AREA A2

Proposed Land Use/ Cover	A, Area (hectares)	R, Runoff Coefficient	A x R
Concrete	0.010	0.90	0.009
Landscape	0.021	0.25	0.005
Overall	0.031	0.46	0.015

**TABLE E3 PEAK FLOWS CALCULATION USING RATIONAL METHOD
EXISTING AND PROPOSED CONDITIONS**

Project: 1050 Klondike Drive, Ottawa, ON

Date: 20-Jun-22

Designed By: UA

Checked By: YA

TABLE E3.1 Intensity-Duration-Frequency Parameters, Ottawa

$$I = A / (td + C)^B \quad td = 10 \text{ min}$$

Return Period	A	B	C
2 year	732.951	0.810	6.199
5 year	998.071	0.814	6.053
10 year	1174.184	0.816	6.014
25 year	1402.884	0.819	6.018
50 year	1569.580	0.820	6.014
100 year	1735.688	0.820	6.041

TABLE E3.2 Peak Flows - Existing Condition for Addition Areas

Existing Condition		Area (ha.)	R	A x R	
Area A1		0.126	0.45	0.06	
T _c = 10 minutes					
Storm Event					
2 year	5 year	10 year	25 year	50 year	100 year
Intensity (mm/hr)					
76.8	104.2	122.1	144.7	161.5	178.3
Peak Flow (l/sec)					
12.06	16.36	19.18	22.72	25.35	35.00

As per pre consultation comments, pre development runoff coefficient "R" is recommended as "0.5" max. As per Brookside Subdivision Storm Drainage Area Plan, "R" is considered as "0.45". Quantity control of 85 l/sec/ha has been used for actual orifice/vortex sizing.

TABLE E3.3 Peak Flows - Proposed Condition

Proposed Condition		Area (ha.)	R	A x R	
Area A1		0.126	0.79	0.10	
T _c = 10 minutes					
Storm Event					
2 year	5 year	10 year	25 year	50 year	100 year
Intensity (mm/hr)					
76.8	104.2	122.1	144.7	161.5	178.3
Peak Flow (l/sec) - Uncontrolled					
21.23	28.80	33.76	39.99	44.63	61.61
Peak Flow (l/sec) - Controlled					
10.71	10.71	10.71	10.71	10.71	10.71

0.990236624

(100 year pre and post development flows are calculated based on increased Runoff coefficient of 25% upto maximum of 1.0)

Allowable @ Release rate 85 L/s/ha (0.85X0.126=10.71 l/sec) Hydro Break (Refer Appendix E for details)

TABLE E3.4 Change in Peak Flows (Reduction -ve; Increase +ve)

Percent Change (%)					
-11.2%	-34.5%	-44.2%	-52.9%	-57.8%	-69.4%

On-Site Storage
Calculator

Ottawa, ON

Project: 1050 Klondike Drive

By: UA

Table E6 -Overall Site

Date: 16-Jun-22

$R = 0.79$ 5 yr rainfall:
 $A = 0.13$ ha
 $Q_{release} = 0.011$ m³/s
 10.71 L/s

T.C (min)	i_5 (mm/hr)	Q_5 (m ³ /s)	Q_{stored} (m ³ /s)	Peak Volume (m ³)
10	104.193	0.029	0.018	10.854
15	83.557	0.023	0.012	11.147 ***
20	70.251	0.019	0.009	10.450
25	60.896	0.017	0.006	9.183
30	53.928	0.015	0.004	7.553
35	48.518	0.013	0.003	5.671
40	44.184	0.012	0.002	3.607
45	40.629	0.011	0.001	1.404
50	37.653	0.010	-	-
55	35.123	0.010	-	-
60	32.943	0.009	-	-
65	31.044	0.009	-	-
70	29.372	0.008	-	-
75	27.888	0.008	-	-
80	26.562	0.007	-	-
85	25.369	0.007	-	-
90	24.288	0.007	-	-
95	23.305	0.006	-	-
100	22.407	0.006	-	-
105	21.582	0.006	-	-

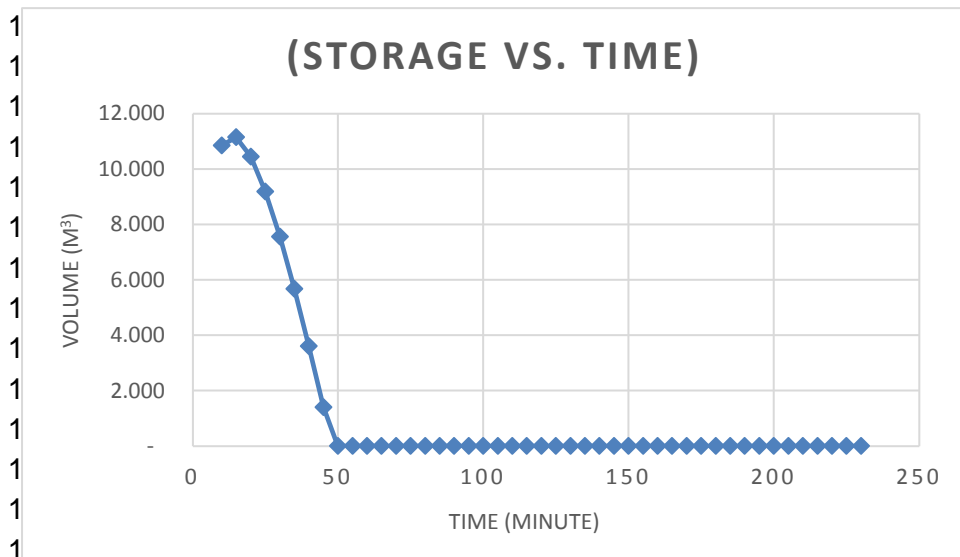

Table E7 - Storm Drainage Design Chart

DESIGN STORM:	5 YEAR RETURN
I (5-YEAR):	$I = A / (td + C)^B$ (mm/hr)
td (start):	10.0 minutes

Jain Infrastructure Consultants Ltd.	
PROJECT:	1050 Klondike Drive
PREPARED BY:	UA
FILE No.:	20-525
DATE PREPARED	15-Jun-22

LOCATION	MANHOLES		A area (ha)	C runoff Coeffi.	A x C	ACC. A x C	td (min)	I (mm/hr)	Q	Q	STORM SEWER DESIGN INFORMATION					TIME	REMARKS
	FROM MH#	TO MH#							(5-YR) (l/s)	(@85 l/sec/ha) (l/s)	size (mm)	slope (%)	length (m)	Q full (l/s)	V full (m/s)	SECT. (min)	
Parking	STM MH1	STM MH2	0.13	0.79	0.10	0.10	10.00	104.91	29	10.9	300	2.00	51.00	137	1.93	0.44	
Parking	STM MH2	STM MH3	0.00	0.79	0.00	0.10	10.44	102.81	29	10.9	300	2.00	2.00	137	1.93	0.02	
Parking	STM MH3	EX. STM Sewer Dia 675mm Line (Sandhill Road)	0.00	0.79	0.00	0.10	10.46	102.73	29	10.9	300	2.00	11.00	137	1.93	0.09	Hydro Break

Technical Specification

Control Point	Head (m)	Flow (l/s)
Primary Design	1.660	10.710
Flush-Flo	0.113	3.391
Kick-Flo®	0.136	3.342
Mean Flow		7.262



PT/329/0412

hydro-int.com/patents

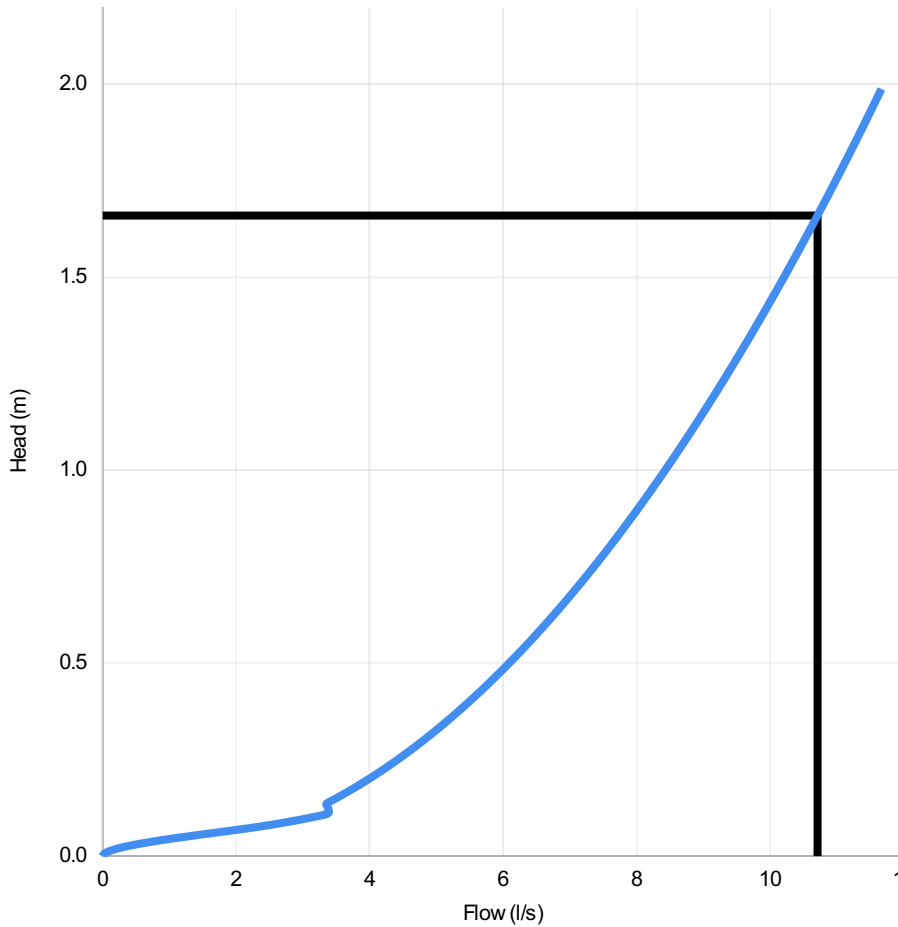

Head (m)	Flow (l/s)
0.000	0.000
0.057	1.537
0.114	3.390
0.172	3.721
0.229	4.244
0.286	4.702
0.343	5.115
0.401	5.494
0.458	5.845
0.515	6.175
0.572	6.486
0.630	6.781
0.687	7.063
0.744	7.333
0.801	7.593
0.859	7.843
0.916	8.085
0.973	8.319
1.030	8.546
1.088	8.767
1.145	8.981
1.202	9.191
1.259	9.395
1.317	9.595
1.374	9.790
1.431	9.981
1.488	10.168
1.546	10.352
1.603	10.532
1.660	10.709

DESIGN ADVICE

The head/flow characteristics of this SCU-0091-1071-1660-1071 Hydro-Brake Optimum® Flow Control are unique. Dynamic hydraulic modeling evaluates the full head/flow characteristic curve.



The use of any other flow control will invalidate any design based on this data and could constitute a flood risk.



DATE	6/16/2022 7:27 PM
Site	
DESIGNER	USMAN ARIF
Ref	

SCU-0091-1071-1660-1071
Hydro-Brake Optimum®

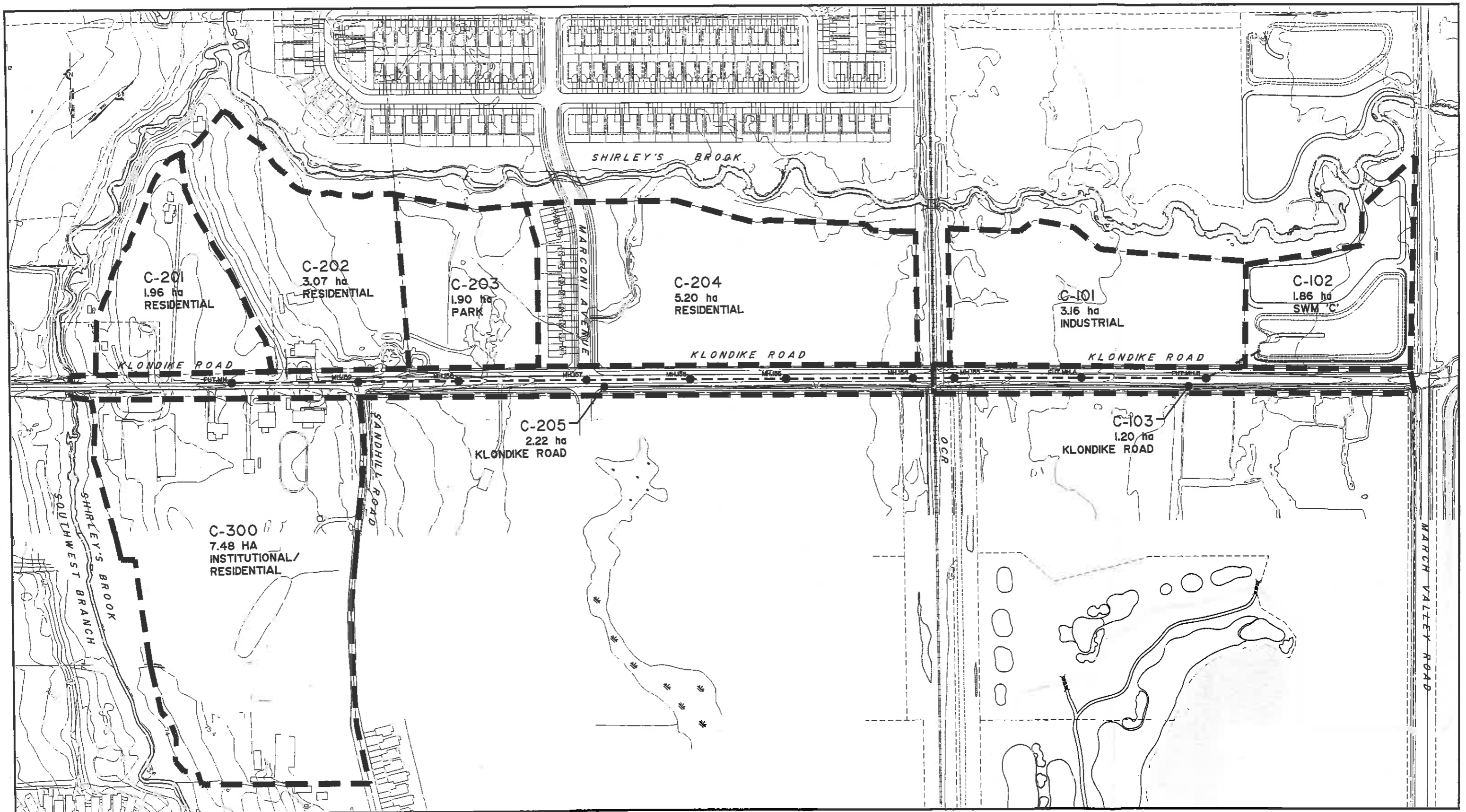

NOVATECH
 ENGINEERING
 CONSULTANTS LTD.
 ENGINEERS & PLANNERS
 Suite 200, 140 Michael Cowland Drive
 Gilroy, Ontario, Canada
 K2M 1P6
 Telephone: (613) 254-9143
 Facsimile: (613) 254-5867
 Email: novinfo@novatech-eng.com

FIGURE 3
 STORM DRAINAGE AREAS
 TO SWM FACILITY 'C'
 103106 MAY 2006 N.T.S.



NOTE: THE POSITION OF ALL POLE LINES, CONDUITS, WATERMANS, SEWERS AND OTHER UNDERGROUND AND OVERGROUND UTILITIES AND STRUCTURES IS NOT NECESSARILY SHOWN ON THE CONTRACT DRAWINGS, AND WHERE SHOWN, THE ACCURACY OF THE POSITION OF SUCH UTILITIES AND STRUCTURES IS NOT GUARANTEED. BEFORE STARTING WORK, DETERMINE THE EXACT LOCATION OF ALL SUCH UTILITIES AND STRUCTURES AND ASSUME ALL LIABILITY FOR DAMAGE TO THEM.

No.	REVISION	DATE	BY	No.	REVISION	DATE	BY
1.	ISSUED TO CITY FOR REVIEW	MAR 20/06	MAB	7.	ISSUED TO CLIENT	OCT 10/06	MAB
2.	ISSUED FOR MOE APPROVAL	NOV 09/06	MAB	8.	ISSUED FOR CONSTRUCTION	AUG 17/06	MAB
3.	ISSUED TO CITY FOR REVIEW	MAR 20/06	MAB	9.	ISSUED WITH MOE APPLICATION	AUG 08/06	MAB
4.	ISSUED FOR TENDER	MAY 26/06	MAB	10.	ISSUED WITH MOE APPLICATION - PHASE 2	OCT 31/07	MAB
5.	ISSUED FOR MOE APPROVAL	MAY 01/06	MAB	11.	ISSUED FOR TENDER	MAY 26/06	MAB
6.	REVISED PER CITY COMMENTS	APR 24/06	MAB	12.	AS-BUILT	JAN 16/14	MAB

NOVATECH
 ENGINEERING CONSULTANTS LTD.
 ENGINEERS & PLANNERS
 Suite 200, 240 Michael Cowpland Drive
 Ottawa, Ontario, Canada
 Telephone: (613) 254-9643
 Facsimile: (613) 254-5967
 Email: novatech@novatech-eng.com

DESIGN	MAB	SCALE	CITY OF OTTAWA
CHECKED	SAY	1:2000	BROOKSIDE SUBDIVISION
DRAWN	SM		SWM FACILITIES
CHECKED	MAB		STORM DRAINAGE AREA PLAN
APPROVED	JGR		

PROJECT No.	103106-0
DATE	AUGUST 2005
DRAWING No.	103106-STMI

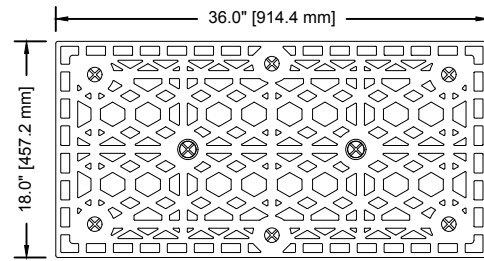

TOP

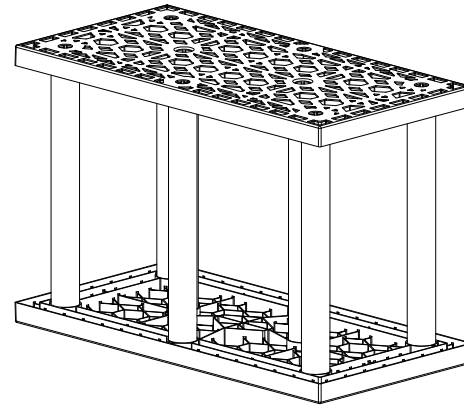

ISOMETRIC VIEW

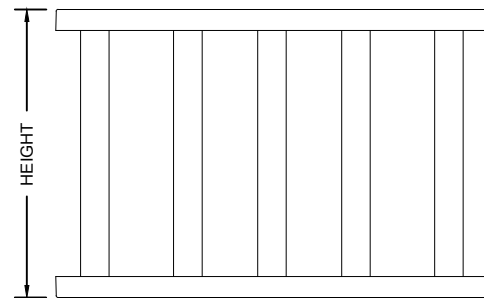

FRONT

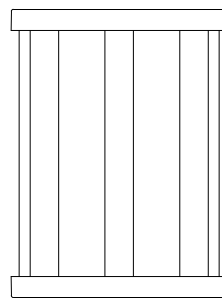

SIDE

MODULE DETAIL

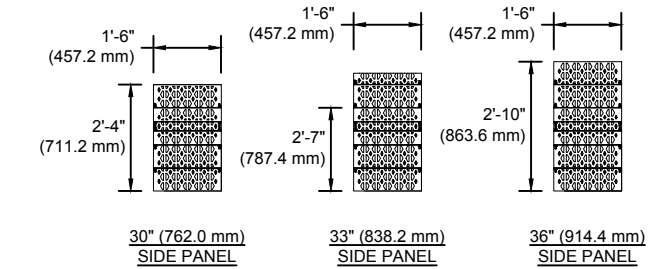
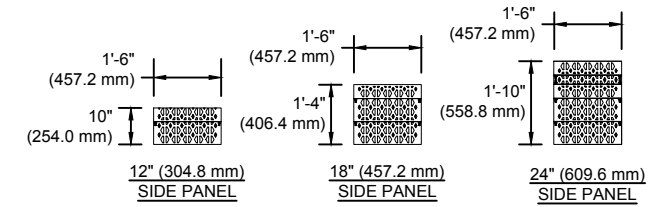

NOTES:

1. SIDE PANELS TO BE INSTALLED ALONG SYSTEM PERIMETER, UNLESS OTHERWISE SPECIFIED.
2. ALL HEIGHTS TO BE CUT FROM A 36" (914.4 mm) SIDE PANEL AT PRE-SCRIBED LOCATIONS, EXCEPT 33" (838.2 mm) & 12" (304.8 mm) SIDE PANEL.

SIDE PANEL DETAIL

STORMTANK® MODULE				
NAME	HEIGHT (mm)	CAPACITY (m ³)	VOID RATIO	NOMINAL WEIGHT (kg)
ST-12	12" (304.8)	4.22 cf (0.1194)	93.70%	17.56 lbs. (7.965)
ST-18	18" (457.2)	6.44 cf (0.1824)	95.50%	22.70 lbs. (10.29)
ST-24	24" (609.6)	8.66 cf (0.2452)	96.00%	26.30 lbs. (11.92)
ST-30	30" (762.0)	10.88 cf (0.3081)	96.50%	29.50 lbs. (13.38)
ST-33	33" (838.2)	11.99 cf (0.3395)	96.90%	29.82 lbs. (13.53)
ST-36	36" (914.4)	13.10 cf (0.3710)	97.00%	33.10 lbs. (15.01)

NOTES:

1. REFERENCE CURRENT INSTALLATION INSTRUCTIONS FOR PROPER ASSEMBLY AND INSTALLATION PRACTICES.
2. SIDE PANELS REQUIRED AROUND THE PERIMETER OF THE INSTALLATION ONLY, UNLESS OTHERWISE NOTED.
3. SIDE PANELS ARE TO BE CUT FROM A 36" PANEL AT THE PRE-SCRIBED LOCATIONS.

REV.	DATE	RECORD OF CHANGES	BY	APPRV.
D	2/17/17	ST-12 MODULE ADDED, METRIC DIMENSIONS UPDATED	CGB	
C	9/12/13	NOTE REVISION, FORMATTING UPDATE & DWG. NO. UPDATE	JKB	JKB
B	9/11/12	FORMATTING & DWG. NO. UPDATE	JKB	FK
A	4/5/12	INITIAL RELEASE	BLL	FK

This is the property of Brentwood Industries, Inc. It may not be reproduced or used for any purpose other than those expressly authorized by Brentwood Industries. It shall be returned immediately upon request of Brentwood Industries.



610 Morgantown Road
Reading, PA 19611 U.S.A.
Phone: (610) 374-5109
Fax: (610) 376-6022
www.brentwoodindustries.com

Project Name MODULE DETAIL	
Title STORMTANK® MODULE	
Drawn By B.LINE	Date 4/5/12
Drawing No. STM-000-00	Sheet 1 of 2
Scale NTS	

Inputs	Project Name:	1050 Klondike Road - Ottawa		Dimensions	Module			
	Engineer:	Jain Infra Consultants Ltd.	Date:		20-Jun-22	Length:	2.7432	m
	Units:	SI	Shape:		Square/Rectangle	Width:	16.002	m
	Liner:	No	Location:		N/A	Excavation		
	Stacking:	Single	Height:		609.6	Length:	3.3528	m
	Stone Storage:	All	Porosity:		40%	Width:	16.6116	m
						Stone		
						Leveling Bed:	0.1524	m
				Top Backfill:	0.3048	m		
				Compacted Fill:	0.3048	m		

Results

Capacity:

Stone Storage Volume:	13.06	m ³
Module Storage Volume:	25.77	m ³
Total Storage Volume:	38.83	m ³

Quantities:

Required Excavation:	76.39	m ³
Required Stone Volume:	32.66	m ³
Estimated Geotextile:	338.14	m ²
Estimated Liner:	0.00	m ²

(Estimations include 10% for scrap and overlap)

Storage Capacity Ratio

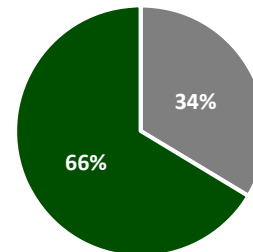

■ Stone Storage Volume: ■ Module Storage Volume:

Basin Detail

Component Quantities:

	Bottom Layer	Top Layer	Total
Height	609.6	N/A	609.6
# of Modules	105	N/A	105
# of Platens	210	N/A	210
# of Side Panels	82	N/A	82
# of Columns	840	N/A	840
# of Stacking Pins	0	N/A	0

Cross-Section:

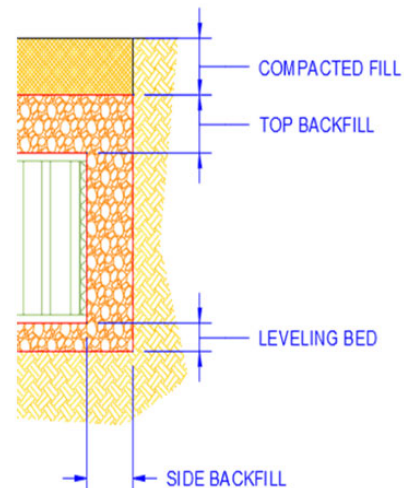



Stage Storage Calculator

Inputs:

Storage Invert = m 1050 Klindike Road, Ottawa, ON

Input Heights to be included in stage storage:

Leveling Bed Depth = m
 Module Height = m
 Top Cover Depth = m

System Footprints:

Module Footprint = m²
 Stone Footprint = m²

Void Space %:

Module Avg. Void = %

* Note, this calculator works to a maximum storage height of 15' including stone leveling bed, module unit and top cover

Increment Step
 Elevation m

Height (m)	Elevation (m)	(Storage Volume Below 74.85) (m ³)	(Storage Volume Above 74.85) (m ³)
0.2024	74.85	5.74	33.08

Height (m)	Elevation (m)	Stone Stage Storage (m ³)	Module Stage Storage (m ³)	Cumulative Stage Storage (m ³)	Cumulative Total Storage (m ³)
0.0000	74.6476	0.00	0.00	0.00	0.00
0.0254	74.6730	0.57	0.00	0.57	0.57
0.0508	74.6984	0.57	0.00	0.57	1.13
0.0762	74.7238	0.57	0.00	0.57	1.70
0.1016	74.7492	0.57	0.00	0.57	2.26
0.1270	74.7746	0.57	0.00	0.57	2.83
0.1524	74.8000	0.57	0.00	0.57	3.40
0.1778	74.8254	0.12	1.07	1.19	4.59
0.2024	74.8500	0.12	1.04	1.16	5.74
0.2032	74.8508	0.00	0.03	0.04	5.78
0.2286	74.8762	0.12	1.07	1.19	6.98
0.2540	74.9016	0.12	1.07	1.19	8.17
0.2794	74.9270	0.12	1.07	1.19	9.36
0.3048	74.9524	0.12	1.07	1.19	10.56
0.3302	74.9778	0.12	1.07	1.19	11.75
0.3556	75.0032	0.12	1.07	1.19	12.94
0.3810	75.0286	0.12	1.07	1.19	14.14
0.4064	75.0540	0.12	1.07	1.19	15.33
0.4318	75.0794	0.12	1.07	1.19	16.52
0.4572	75.1048	0.12	1.07	1.19	17.72
0.4826	75.1302	0.12	1.07	1.19	18.91
0.5080	75.1556	0.12	1.07	1.19	20.10
0.5334	75.1810	0.12	1.07	1.19	21.30
0.5588	75.2064	0.12	1.07	1.19	22.49
0.5842	75.2318	0.12	1.07	1.19	23.68
0.6096	75.2572	0.12	1.07	1.19	24.88
0.6350	75.2826	0.12	1.07	1.19	26.07
0.6604	75.3080	0.12	1.07	1.19	27.26
0.6858	75.3334	0.12	1.07	1.19	28.46
0.7112	75.3588	0.12	1.07	1.19	29.65
0.7366	75.3842	0.12	1.07	1.19	30.84
0.7620	75.4096	0.12	1.07	1.19	32.04
0.7874	75.4350	0.57	0.00	0.57	32.60
0.8128	75.4604	0.57	0.00	0.57	33.17
0.8382	75.4858	0.57	0.00	0.57	33.74
0.8636	75.5112	0.57	0.00	0.57	34.30
0.8890	75.5366	0.57	0.00	0.57	34.87
0.9144	75.5620	0.57	0.00	0.57	35.43
0.9398	75.5874	0.57	0.00	0.57	36.00
0.9652	75.6128	0.57	0.00	0.57	36.57
0.9906	75.6382	0.57	0.00	0.57	37.13
1.0160	75.6636	0.57	0.00	0.57	37.70
1.0414	75.6890	0.57	0.00	0.57	38.26
1.0668	75.7144	0.57	0.00	0.57	38.83
		13.06	25.77	38.83	

Stormceptor® EF Sizing Report

STORMCEPTOR®

ESTIMATED NET ANNUAL SEDIMENT (TSS) LOAD REDUCTION

11/12/2021

Province:	Ontario
City:	OTTAWA
Nearest Rainfall Station:	OTTAWA CDA RCS
Climate Station Id:	6105978
Years of Rainfall Data:	20

Project Name:	1050 KLONDIKE DRIVE
Project Number:	20-525
Designer Name:	USMAN ARIF
Designer Company:	Jain Infrastructure Consultants
Designer Email:	uarif@jainconsultants.com
Designer Phone:	647-510-0353
EOR Name:	
EOR Company:	
EOR Email:	
EOR Phone:	

Site Name:	
------------	--

Drainage Area (ha):	0.13
Runoff Coefficient 'c':	0.98

Particle Size Distribution:	Fine
Target TSS Removal (%):	80.0

Required Water Quality Runoff Volume Capture (%):	90.00
Estimated Water Quality Flow Rate (L/s):	4.32
Oil / Fuel Spill Risk Site?	Yes
Upstream Flow Control?	Yes
Upstream Orifice Control Flow Rate to Stormceptor (L/s):	10.88
Peak Conveyance (maximum) Flow Rate (L/s):	
Site Sediment Transport Rate (kg/ha/yr):	

Net Annual Sediment (TSS) Load Reduction Sizing Summary	
Stormceptor Model	TSS Removal Provided (%)
EFO4	92
EFO6	97
EFO8	99
EFO10	100
EFO12	100

Recommended Stormceptor EFO Model: EFO4
Estimated Net Annual Sediment (TSS) Load Reduction (%): 92
Water Quality Runoff Volume Capture (%): > 90



Stormceptor® EF Sizing Report

THIRD-PARTY TESTING AND VERIFICATION

► **Stormceptor® EF and Stormceptor® EFO** are the latest evolutions in the Stormceptor® oil-grit separator (OGS) technology series, and are designed to remove a wide variety of pollutants from stormwater and snowmelt runoff. These technologies have been third-party tested in accordance with the Canadian ETV **Procedure for Laboratory Testing of Oil-Grit Separators** and performance has been third-party verified in accordance with the **ISO 14034 Environmental Technology Verification (ETV)** protocol.

PERFORMANCE

► **Stormceptor® EF and EFO** remove stormwater pollutants through gravity separation and floatation, and feature a patent-pending design that generates positive removal of total suspended solids (TSS) throughout each storm event, including high-intensity storms. Captured pollutants include sediment, free oils, and sediment-bound pollutants such as nutrients, heavy metals, and petroleum hydrocarbons. Stormceptor is sized to remove a high level of TSS from the frequent rainfall events that contribute the vast majority of annual runoff volume and pollutant load. The technology incorporates an internal bypass to convey excessive stormwater flows from high-intensity storms through the device without resuspension and washout (scour) of previously captured pollutants. Proper routine maintenance ensures high pollutant removal performance and protection of downstream waterways.

PARTICLE SIZE DISTRIBUTION (PSD)

► The **Canadian ETV PSD** shown in the table below was used, or in part, for this sizing. This is the identical PSD that is referenced in the Canadian ETV **Procedure for Laboratory Testing of Oil-Grit Separators** for both sediment removal testing and scour testing. The Canadian ETV PSD contains a wide range of particle sizes in the sand and silt fractions, and is considered reasonably representative of the particle size fractions found in typical urban stormwater runoff.

Particle Size (µm)	Percent Less Than	Particle Size Fraction (µm)	Percent
1000	100	500-1000	5
500	95	250-500	5
250	90	150-250	15
150	75	100-150	15
100	60	75-100	10
75	50	50-75	5
50	45	20-50	10
20	35	8-20	15
8	20	5-8	10
5	10	2-5	5
2	5	<2	5

Stormceptor®EF Sizing Report

Upstream Flow Controlled Results

Rainfall Intensity (mm / hr)	Percent Rainfall Volume (%)	Cumulative Rainfall Volume (%)	Flow Rate (L/s)	Flow Rate (L/min)	Surface Loading Rate (L/min/m ²)	Removal Efficiency (%)	Incremental Removal (%)	Cumulative Removal (%)
1	22.3	22.3	0.35	21.0	18.0	100	22.3	22.3
2	17.8	40.0	0.71	43.0	35.0	100	17.8	40.0
3	13.1	53.1	1.06	64.0	53.0	98	12.9	52.9
4	9.2	62.4	1.42	85.0	71.0	94	8.7	61.6
5	6.5	68.9	1.77	106.0	89.0	91	5.9	67.5
6	5.1	74.0	2.13	128.0	106.0	89	4.5	72.0
7	3.4	77.3	2.48	149.0	124.0	87	2.9	74.9
8	3.0	80.3	2.83	170.0	142.0	84	2.5	77.5
9	3.6	84.0	3.19	191.0	159.0	82	3.0	80.5
10	2.5	86.5	3.54	213.0	177.0	81	2.0	82.5
11	1.7	88.2	3.90	234.0	195.0	78	1.3	83.8
12	1.4	89.6	4.25	255.0	213.0	77	1.1	84.9
13	1.9	91.5	4.60	276.0	230.0	76	1.4	86.4
14	1.3	92.8	4.96	298.0	248.0	75	1.0	87.4
15	1.3	94.1	5.31	319.0	266.0	75	0.9	88.3
16	0.8	94.9	5.67	340.0	283.0	74	0.6	88.9
17	0.8	95.7	6.02	361.0	301.0	73	0.6	89.5
18	0.4	96.1	6.38	383.0	319.0	72	0.3	89.8
19	0.5	96.6	6.73	404.0	336.0	72	0.3	90.1
20	0.2	96.8	7.08	425.0	354.0	71	0.2	90.3
21	0.5	97.3	7.44	446.0	372.0	70	0.4	90.6
22	0.3	97.6	7.79	468.0	390.0	69	0.2	90.8
23	1.1	98.7	8.15	489.0	407.0	69	0.8	91.6
24	0.3	99.0	8.50	510.0	425.0	68	0.2	91.8
25	0.0	99.0	8.85	531.0	443.0	67	0.0	91.8
30	1.0	100.0	10.63	638.0	531.0	63	0.6	92.4
35	0.0	100.0	11.00	660.0	550.0	62	0.0	92.4
40	0.0	100.0	11.00	660.0	550.0	62	0.0	92.4
45	0.0	100.0	11.00	660.0	550.0	62	0.0	92.4
50	0.0	100.0	11.00	660.0	550.0	62	0.0	92.4
Estimated Net Annual Sediment (TSS) Load Reduction =								92 %

Climate Station ID: 6105978 Years of Rainfall Data: 20



Stormceptor® EF Sizing Report

RAINFALL DATA FROM OTTAWA CDA RCS RAINFALL STATION

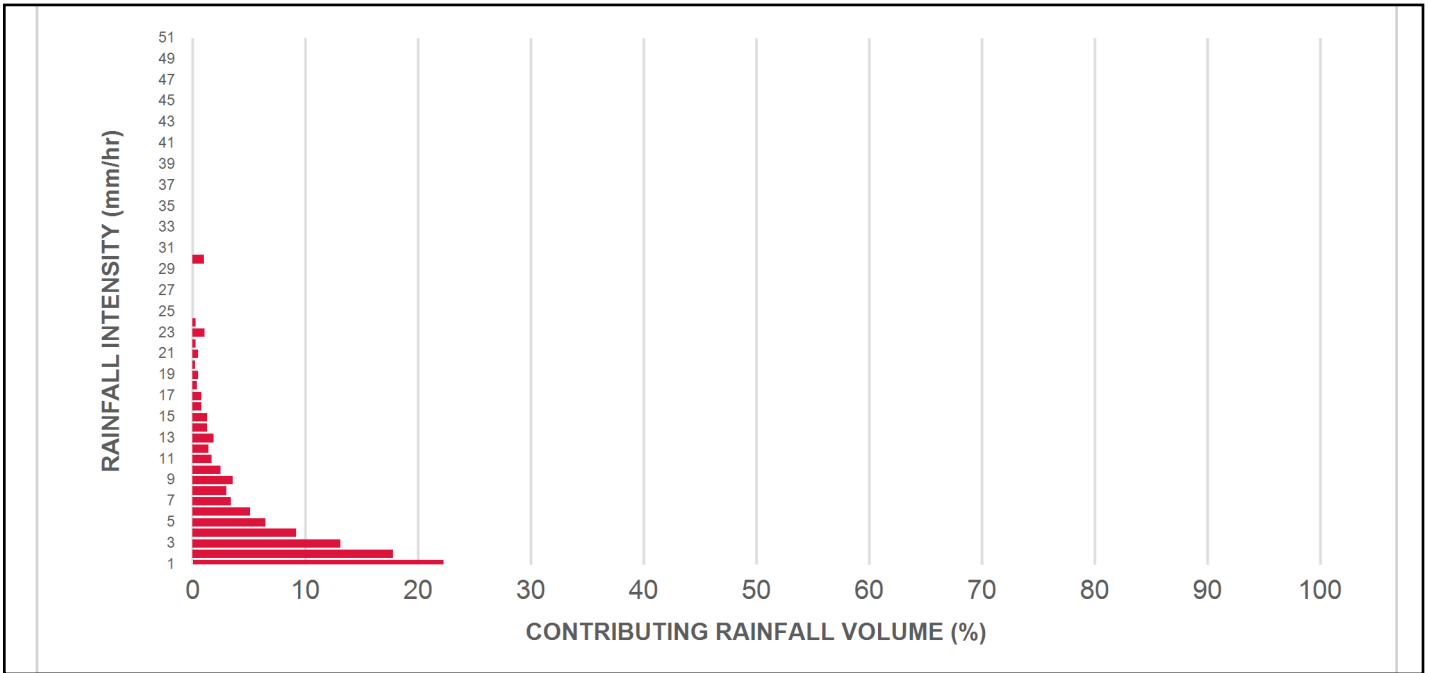

INCREMENTAL AND CUMULATIVE TSS REMOVAL FOR THE RECOMMENDED STORMCEPTOR® MODEL

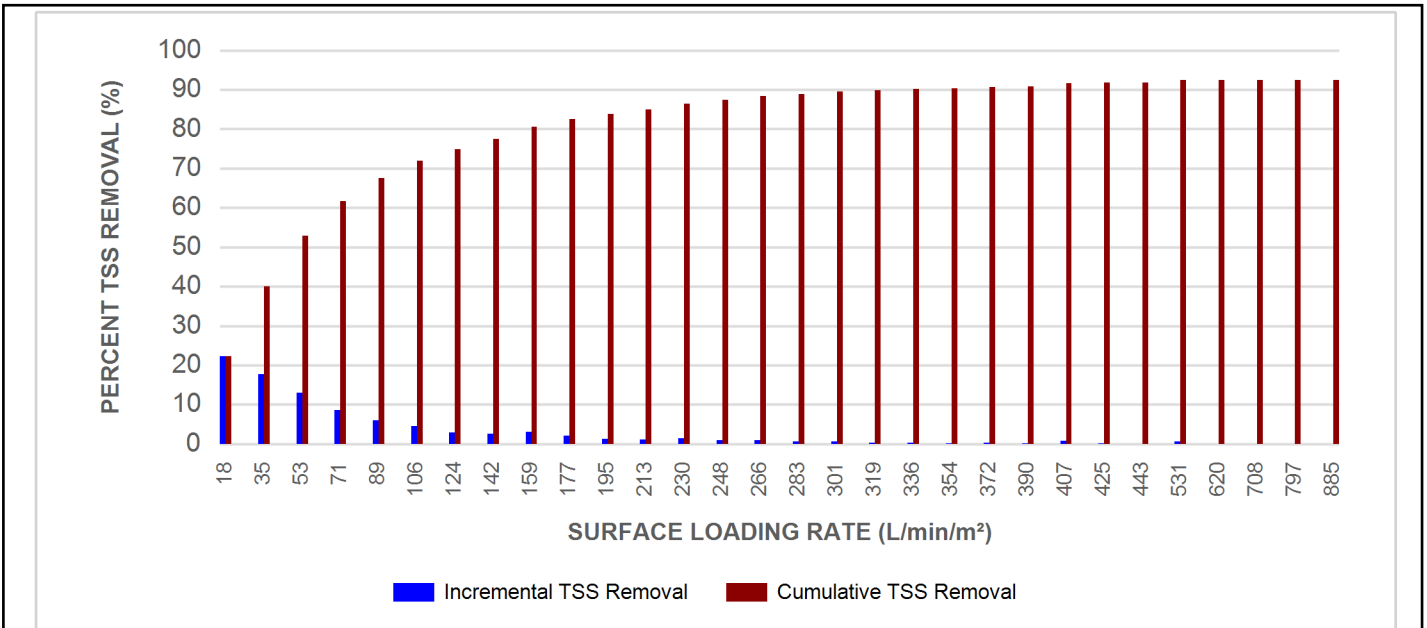

Stormceptor® **EF** Sizing Report

Maximum Pipe Diameter / Peak Conveyance

Stormceptor EF / EFO	Model Diameter		Min Angle Inlet / Outlet Pipes	Max Inlet Pipe Diameter		Max Outlet Pipe Diameter		Peak Conveyance Flow Rate	
	(m)	(ft)		(mm)	(in)	(mm)	(in)	(L/s)	(cfs)
EF4 / EFO4	1.2	4	90	609	24	609	24	425	15
EF6 / EFO6	1.8	6	90	914	36	914	36	990	35
EF8 / EFO8	2.4	8	90	1219	48	1219	48	1700	60
EF10 / EFO10	3.0	10	90	1828	72	1828	72	2830	100
EF12 / EFO12	3.6	12	90	1828	72	1828	72	2830	100

SCOUR PREVENTION AND ONLINE CONFIGURATION

► Stormceptor® EF and EFO feature an internal bypass and superior scour prevention technology that have been demonstrated in third-party testing according to the scour testing provisions of the Canadian ETV **Procedure for Laboratory Testing of Oil-Grit Separators**, and the exceptional scour test performance has been third-party verified in accordance with the ISO 14034 ETV protocol. As a result, Stormceptor EF and EFO are approved for online installation, eliminating the need for costly additional bypass structures, piping, and installation expense.

DESIGN FLEXIBILITY

► Stormceptor® EF and EFO offers design flexibility in one simplified platform, accepting stormwater flow from a single inlet pipe or multiple inlet pipes, and/or surface runoff through an inlet grate. The device can also serve as a junction structure, accommodate a 90-degree inlet-to-outlet bend angle, and can be modified to ensure performance in submerged conditions.

OIL CAPTURE AND RETENTION

► While Stormceptor® EF will capture and retain oil from dry weather spills and low intensity runoff, Stormceptor® EFO has demonstrated superior oil capture and greater than 99% oil retention in third-party testing according to the light liquid re-entrainment testing provisions of the Canadian ETV **Procedure for Laboratory Testing of Oil-Grit Separators**. Stormceptor EFO is recommended for sites where oil capture and retention is a requirement.

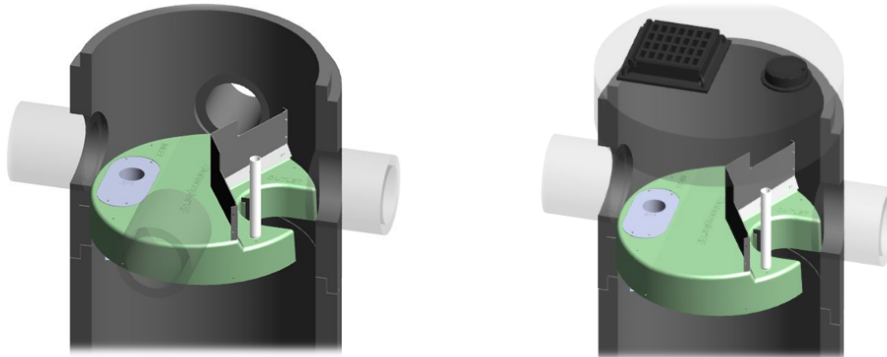

Stormceptor® EF Sizing Report

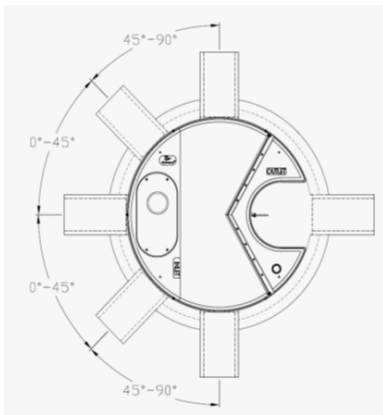

INLET-TO-OUTLET DROP

Elevation differential between inlet and outlet pipe inverts is dictated by the angle at which the inlet pipe(s) enters the unit.

0° - 45° : The inlet pipe is 1-inch (25mm) higher than the outlet pipe.

45° - 90° : The inlet pipe is 2-inches (50mm) higher than the outlet pipe.

HEAD LOSS

The head loss through Stormceptor EF is similar to that of a 60-degree bend structure. The applicable K value for calculating minor losses through the unit is 1.1.

For submerged conditions the applicable K value is 3.0.

Pollutant Capacity

Stormceptor EF / EFO	Model Diameter		Depth (Outlet Pipe Invert to Sump Floor)		Oil Volume		Recommended Sediment Maintenance Depth *		Maximum Sediment Volume *		Maximum Sediment Mass **	
	(m)	(ft)	(m)	(ft)	(L)	(Gal)	(mm)	(in)	(L)	(ft³)	(kg)	(lb)
EF4 / EFO4	1.2	4	1.52	5.0	265	70	203	8	1190	42	1904	5250
EF6 / EFO6	1.8	6	1.93	6.3	610	160	305	12	3470	123	5552	15375
EF8 / EFO8	2.4	8	2.59	8.5	1070	280	610	24	8780	310	14048	38750
EF10 / EFO10	3.0	10	3.25	10.7	1670	440	610	24	17790	628	28464	78500
EF12 / EFO12	3.6	12	3.89	12.8	2475	655	610	24	31220	1103	49952	137875

*Increased sump depth may be added to increase sediment storage capacity

** Average density of wet packed sediment in sump = 1.6 kg/L (100 lb/ft³)

Feature	Benefit	Feature Appeals To
Patent-pending enhanced flow treatment and scour prevention technology	Superior, verified third-party performance	Regulator, Specifying & Design Engineer
Third-party verified light liquid capture and retention for EFO version	Proven performance for fuel/oil hotspot locations	Regulator, Specifying & Design Engineer, Site Owner
Functions as bend, junction or inlet structure	Design flexibility	Specifying & Design Engineer
Minimal drop between inlet and outlet	Site installation ease	Contractor
Large diameter outlet riser for inspection and maintenance	Easy maintenance access from grade	Maintenance Contractor & Site Owner

STANDARD STORMCEPTOR EF/EFO DRAWINGS

For standard details, please visit <http://www.imbriumsystems.com/stormwater-treatment-solutions/stormceptor-ef>

STANDARD STORMCEPTOR EF/EFO SPECIFICATION

For specifications, please visit <http://www.imbriumsystems.com/stormwater-treatment-solutions/stormceptor-ef>

Stormceptor® **EF** Sizing Report

**STANDARD PERFORMANCE SPECIFICATION FOR
“OIL GRIT SEPARATOR” (OGS) STORMWATER QUALITY TREATMENT DEVICE**

PART 1 – GENERAL

1.1 WORK INCLUDED

This section specifies requirements for selecting, sizing, and designing an underground Oil Grit Separator (OGS) device for stormwater quality treatment, with third-party testing results and a Statement of Verification in accordance with ISO 14034 Environmental Management – Environmental Technology Verification (ETV).

1.2 REFERENCE STANDARDS & PROCEDURES

ISO 14034:2016 Environmental management – Environmental technology verification (ETV)

Canadian Environmental Technology Verification (ETV) Program’s **Procedure for Laboratory Testing of Oil-Grit Separators**

1.3 SUBMITTALS

1.3.1 All submittals, including sizing reports & shop drawings, shall be submitted upon request with each order to the contractor then forwarded to the Engineer of Record for review and acceptance. Shop drawings shall detail all OGS components, elevations, and sequence of construction.

1.3.2 Alternative devices shall have features identical to or greater than the specified device, including: treatment chamber diameter, treatment chamber wet volume, sediment storage volume, and oil storage volume.

1.3.3 Unless directed otherwise by the Engineer of Record, OGS stormwater quality treatment product substitutions or alternatives submitted within ten days prior to project bid shall not be accepted. All alternatives or substitutions submitted shall be signed and sealed by a local registered Professional Engineer, based on the exact same criteria detailed in Section 3, in entirety, subject to review and approval by the Engineer of Record.

PART 2 – PRODUCTS

2.1 OGS POLLUTANT STORAGE

The OGS device shall include a sump for sediment storage, and a protected volume for the capture and storage of petroleum hydrocarbons and buoyant gross pollutants. The minimum sediment & petroleum hydrocarbon storage capacity shall be as follows:

2.1.1	4 ft (1219 mm) Diameter OGS Units:	1.19 m ³ sediment / 265 L oil
	6 ft (1829 mm) Diameter OGS Units:	3.48 m ³ sediment / 609 L oil
	8 ft (2438 mm) Diameter OGS Units:	8.78 m ³ sediment / 1,071 L oil
	10 ft (3048 mm) Diameter OGS Units:	17.78 m ³ sediment / 1,673 L oil
	12 ft (3657 mm) Diameter OGS Units:	31.23 m ³ sediment / 2,476 L oil

PART 3 – PERFORMANCE & DESIGN

3.1 GENERAL

The OGS stormwater quality treatment device shall be verified in accordance with ISO 14034:2016 Environmental management – Environmental technology verification (ETV). The OGS stormwater quality treatment device shall



Stormceptor®EF Sizing Report

remove oil, sediment and gross pollutants from stormwater runoff during frequent wet weather events, and retain these pollutants during less frequent high flow wet weather events below the insert within the OGS for later removal during maintenance. The Manufacturer shall have at least ten (10) years of local experience, history and success in engineering design, manufacturing and production and supply of OGS stormwater quality treatment device systems, acceptable to the Engineer of Record.

3.2 SIZING METHODOLOGY

The OGS device shall be engineered, designed and sized to provide stormwater quality treatment based on treating a minimum of 90 percent of the average annual runoff volume and a minimum removal of an annual average 60% of the sediment (TSS) load based on the Particle Size Distribution (PSD) specified in the sizing report for the specified device. Sizing shall be determined using historical rainfall data and a sediment removal performance curve derived from the actual third-party verified laboratory testing data. The OGS device shall also have sufficient annual sediment storage capacity as specified and calculated in Section 2.1.

3.3 CANADIAN ETV or ISO 14034 ETV VERIFICATION OF SCOUR TESTING

The OGS device shall have Canadian ETV or ISO 14034 ETV Verification of third-party scour testing conducted in accordance with the Canadian ETV Program's **Procedure for Laboratory Testing of Oil-Grit Separators**.

3.3.1 To be acceptable for on-line installation, the OGS device must demonstrate an average scour test effluent concentration less than 10 mg/L at each surface loading rate tested, up to and including 2600 L/min/m².

3.4 LIGHT LIQUID RE-ENTRAINMENT SIMULATION TESTING

The OGS device shall have Canadian ETV or ISO 14034 ETV Verification of completed third-party Light Liquid Re-entrainment Simulation Testing in accordance with the Canadian ETV **Program's Procedure for Laboratory Testing of Oil-Grit Separators**, with results reported within the Canadian ETV or ISO 14034 ETV verification. This re-entrainment testing is conducted with the device pre-loaded with low density polyethylene (LDPE) plastic beads as a surrogate for light liquids such as oil and fuel. Testing is conducted on the same OGS unit tested for sediment removal to assess whether light liquids captured after a spill are effectively retained at high flow rates.

3.4.1 For an OGS device to be an acceptable stormwater treatment device on a site where vehicular traffic occurs and the potential for an oil or fuel spill exists, the OGS device must have reported verified performance results of greater than 99% cumulative retention of LDPE plastic beads for the five specified surface loading rates (ranging 200 L/min/m² to 2600 L/min/m²) in accordance with the Light Liquid Re-entrainment Simulation Testing within the Canadian ETV Program's **Procedure for Laboratory Testing of Oil-Grit Separators**. However, an OGS device shall not be allowed if the Light Liquid Re-entrainment Simulation Testing was performed with screening components within the OGS device that are effective at retaining the LDPE plastic beads, but would not be expected to retain light liquids such as oil and fuel.

Appendix F
Site Servicing Checklist

Servicing study guidelines for development applications

4. Development Servicing Study Checklist

The following section describes the checklist of the required content of servicing studies. It is expected that the proponent will address each one of the following items for the study to be deemed complete and ready for review by City of Ottawa Infrastructure Approvals staff.

The level of required detail in the Servicing Study will increase depending on the type of application. For example, for Official Plan amendments and re-zoning applications, the main issues will be to determine the capacity requirements for the proposed change in land use and confirm this against the existing capacity constraint, and to define the solutions, phasing of works and the financing of works to address the capacity constraint. For subdivisions and site plans, the above will be required with additional detailed information supporting the servicing within the development boundary.

4.1 General Content

- Executive Summary (for larger reports only).
- Date and revision number of the report.
- Location map and plan showing municipal address, boundary, and layout of proposed development.
- Plan showing the site and location of all existing services.
- Development statistics, land use, density, adherence to zoning and official plan, and reference to applicable subwatershed and watershed plans that provide context to which individual developments must adhere.
- Summary of Pre-consultation Meetings with City and other approval agencies.
- Reference and confirm conformance to higher level studies and reports (Master Servicing Studies, Environmental Assessments, Community Design Plans), or in the case where it is not in conformance, the proponent must provide justification and develop a defensible design criteria.
- Statement of objectives and servicing criteria.
- Identification of existing and proposed infrastructure available in the immediate area.
- Identification of Environmentally Significant Areas, watercourses and Municipal Drains potentially impacted by the proposed development (Reference can be made to the Natural Heritage Studies, if available).
- Concept level master grading plan to confirm existing and proposed grades in the development. This is required to confirm the feasibility of proposed stormwater management and drainage, soil removal and fill constraints, and potential impacts to neighbouring properties. This is also required to confirm that the proposed grading will not impede existing major system flow paths.
- Identification of potential impacts of proposed piped services on private services (such as wells and septic fields on adjacent lands) and mitigation required to address potential impacts.
- Proposed phasing of the development, if applicable.

- Reference to geotechnical studies and recommendations concerning servicing.
- All preliminary and formal site plan submissions should have the following information:
 - Metric scale
 - North arrow (including construction North)
 - Key plan
 - Name and contact information of applicant and property owner
 - Property limits including bearings and dimensions
 - Existing and proposed structures and parking areas
 - Easements, road widening and rights-of-way
 - Adjacent street names

4.2 Development Servicing Report: Water

- Confirm consistency with Master Servicing Study, if available
- Availability of public infrastructure to service proposed development
- Identification of system constraints
- Identify boundary conditions
- Confirmation of adequate domestic supply and pressure
- Confirmation of adequate fire flow protection and confirmation that fire flow is calculated as per the Fire Underwriter's Survey. Output should show available fire flow at locations throughout the development.
- Provide a check of high pressures. If pressure is found to be high, an assessment is required to confirm the application of pressure reducing valves.
- Definition of phasing constraints. Hydraulic modeling is required to confirm servicing for all defined phases of the project including the ultimate design
- Address reliability requirements such as appropriate location of shut-off valves
- Check on the necessity of a pressure zone boundary modification.
- Reference to water supply analysis to show that major infrastructure is capable of delivering sufficient water for the proposed land use. This includes data that shows that the expected demands under average day, peak hour and fire flow conditions provide water within the required pressure range

- Description of the proposed water distribution network, including locations of proposed connections to the existing system, provisions for necessary looping, and appurtenances (valves, pressure reducing valves, valve chambers, and fire hydrants) including special metering provisions.
- Description of off-site required feeder mains, booster pumping stations, and other water infrastructure that will be ultimately required to service proposed development, including financing, interim facilities, and timing of implementation.
- Confirmation that water demands are calculated based on the City of Ottawa Design Guidelines.
- Provision of a model schematic showing the boundary conditions locations, streets, parcels, and building locations for reference.

4.3 Development Servicing Report: Wastewater

- Summary of proposed design criteria (Note: Wet-weather flow criteria should not deviate from the City of Ottawa Sewer Design Guidelines. Monitored flow data from relatively new infrastructure cannot be used to justify capacity requirements for proposed infrastructure).
- Confirm consistency with Master Servicing Study and/or justifications for deviations.
- Consideration of local conditions that may contribute to extraneous flows that are higher than the recommended flows in the guidelines. This includes groundwater and soil conditions, and age and condition of sewers.
- Description of existing sanitary sewer available for discharge of wastewater from proposed development.
- Verify available capacity in downstream sanitary sewer and/or identification of upgrades necessary to service the proposed development. (Reference can be made to previously completed Master Servicing Study if applicable)
- Calculations related to dry-weather and wet-weather flow rates from the development in standard MOE sanitary sewer design table (Appendix 'C') format.
- Description of proposed sewer network including sewers, pumping stations, and forcemains.
- Discussion of previously identified environmental constraints and impact on servicing (environmental constraints are related to limitations imposed on the development in order to preserve the physical condition of watercourses, vegetation, soil cover, as well as protecting against water quantity and quality).
- Pumping stations: impacts of proposed development on existing pumping stations or requirements for new pumping station to service development.
- Forcemain capacity in terms of operational redundancy, surge pressure and maximum flow velocity.
- Identification and implementation of the emergency overflow from sanitary pumping stations in relation to the hydraulic grade line to protect against basement flooding.
- Special considerations such as contamination, corrosive environment etc.

4.4 Development Servicing Report: Stormwater Checklist

- Description of drainage outlets and downstream constraints including legality of outlets (i.e. municipal drain, right-of-way, watercourse, or private property)
- Analysis of available capacity in existing public infrastructure.
- A drawing showing the subject lands, its surroundings, the receiving watercourse, existing drainage patterns, and proposed drainage pattern.
- Water quantity control objective (e.g. controlling post-development peak flows to pre-development level for storm events ranging from the 2 or 5 year event (dependent on the receiving sewer design) to 100 year return period); if other objectives are being applied, a rationale must be included with reference to hydrologic analyses of the potentially affected subwatersheds, taking into account long-term cumulative effects.
- Water Quality control objective (basic, normal or enhanced level of protection based on the sensitivities of the receiving watercourse) and storage requirements.
- Description of the stormwater management concept with facility locations and descriptions with references and supporting information.
- Set-back from private sewage disposal systems.
- Watercourse and hazard lands setbacks.
- Record of pre-consultation with the Ontario Ministry of Environment and the Conservation Authority that has jurisdiction on the affected watershed.
- Confirm consistency with sub-watershed and Master Servicing Study, if applicable study exists.
- Storage requirements (complete with calculations) and conveyance capacity for minor events (1:5 year return period) and major events (1:100 year return period).
- Identification of watercourses within the proposed development and how watercourses will be protected, or, if necessary, altered by the proposed development with applicable approvals.
- Calculate pre and post development peak flow rates including a description of existing site conditions and proposed impervious areas and drainage catchments in comparison to existing conditions.
- Any proposed diversion of drainage catchment areas from one outlet to another.
- Proposed minor and major systems including locations and sizes of stormwater trunk sewers, and stormwater management facilities.
- If quantity control is not proposed, demonstration that downstream system has adequate capacity for the post-development flows up to and including the 100 year return period storm event.
- Identification of potential impacts to receiving watercourses
- Identification of municipal drains and related approval requirements.
- Descriptions of how the conveyance and storage capacity will be achieved for the development.
- 100 year flood levels and major flow routing to protect proposed development from flooding for establishing minimum building elevations (MBE) and overall grading.

- Inclusion of hydraulic analysis including hydraulic grade line elevations.
- Description of approach to erosion and sediment control during construction for the protection of receiving watercourse or drainage corridors.
- Identification of floodplains – proponent to obtain relevant floodplain information from the appropriate Conservation Authority. The proponent may be required to delineate floodplain elevations to the satisfaction of the Conservation Authority if such information is not available or if information does not match current conditions.
- Identification of fill constraints related to floodplain and geotechnical investigation.

4.5 Approval and Permit Requirements: Checklist

The Servicing Study shall provide a list of applicable permits and regulatory approvals necessary for the proposed development as well as the relevant issues affecting each approval. The approval and permitting shall include but not be limited to the following:

- Conservation Authority as the designated approval agency for modification of floodplain, potential impact on fish habitat, proposed works in or adjacent to a watercourse, cut/fill permits and Approval under Lakes and Rivers Improvement Act. The Conservation Authority is not the approval authority for the Lakes and Rivers Improvement Act. Where there are Conservation Authority regulations in place, approval under the Lakes and Rivers Improvement Act is not required, except in cases of dams as defined in the Act.
- Application for Certificate of Approval (CofA) under the Ontario Water Resources Act.
- Changes to Municipal Drains.
- Other permits (National Capital Commission, Parks Canada, Public Works and Government Services Canada, Ministry of Transportation etc.)

4.6 Conclusion Checklist

- Clearly stated conclusions and recommendations
- Comments received from review agencies including the City of Ottawa and information on how the comments were addressed. Final sign-off from the responsible reviewing agency.
- All draft and final reports shall be signed and stamped by a professional Engineer registered in Ontario

Appendix G
Topographic and Legal Survey

SURVEYOR'S REAL PROPERTY REPORT
PART 1 Plan of
PART OF LOT 10 CONCESSION 4
GEOGRAPHIC TOWNSHIP OF MARCH
CITY OF OTTAWA
 Surveyed by Annis, O'Sullivan, Vollebek Ltd.

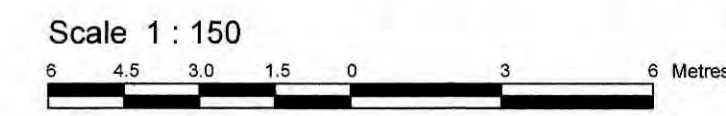

Metric
 DISTANCES SHOWN ON THIS PLAN ARE IN METRES AND
 CAN BE CONVERTED TO FEET BY DIVIDING BY 0.3048

Surveyor's Certificate
 I CERTIFY THAT:
 1. This survey and plan are correct and in accordance with the Surveys Act and the Surveyors Act and the regulations made under them.
 2. The survey was completed on the 14th day of September, 2020.

Sept 21, 2020
 Date
 E. H. Herweyer
 Ontario Land Surveyor

PART 2
 THIS PLAN MUST BE READ IN CONJUNCTION WITH
 SURVEY REPORT DATED: September 21, 2020

ANNIS, O'SULLIVAN, VOLLEBEK LTD. grants to
 the Client, (The Client), their solicitors,
 mortgagees, and other related parties, permission to use original, signed, sealed
 copies of the Surveyor's Real Property Report in transactions involving The Client.

Notes & Legend

Denotes	
	Survey Monument Planted
	Standard Iron Bar
	Short Standard Iron Bar
	Iron Bar
	Witness
	Measured
	Annis, O'Sullivan, Vollebek Ltd.
	Plan 5R-7561
	(1442) Plan August 10, 1989
	Plan 5R-6127
	Plan 4R-14643
	Inst. N499485
	Deciduous Tree
	Coniferous Tree
	Fire Hydrant
	Water Valve
	Maintenance Hole (Storm Sewer)
	Maintenance Hole (Sanitary)
	Valve Chamber (Watermain)
	Underground Sanitary Sewer
	Underground Storm Sewer
	Underground Water
	Underground Gas
	Overhead Wires
	Bell
	Catch Basin
	Ditch Inlet
	Hydro Meter
	Bell Terminal Box
	Chain Link Fence
	Location of Elevations
	Top of Concrete Curb / RW Elevation
	Centreline
	Retaining Wall
	Hydro Transformer
	Tactile Walking Surface Indicator
	Monitoring Well

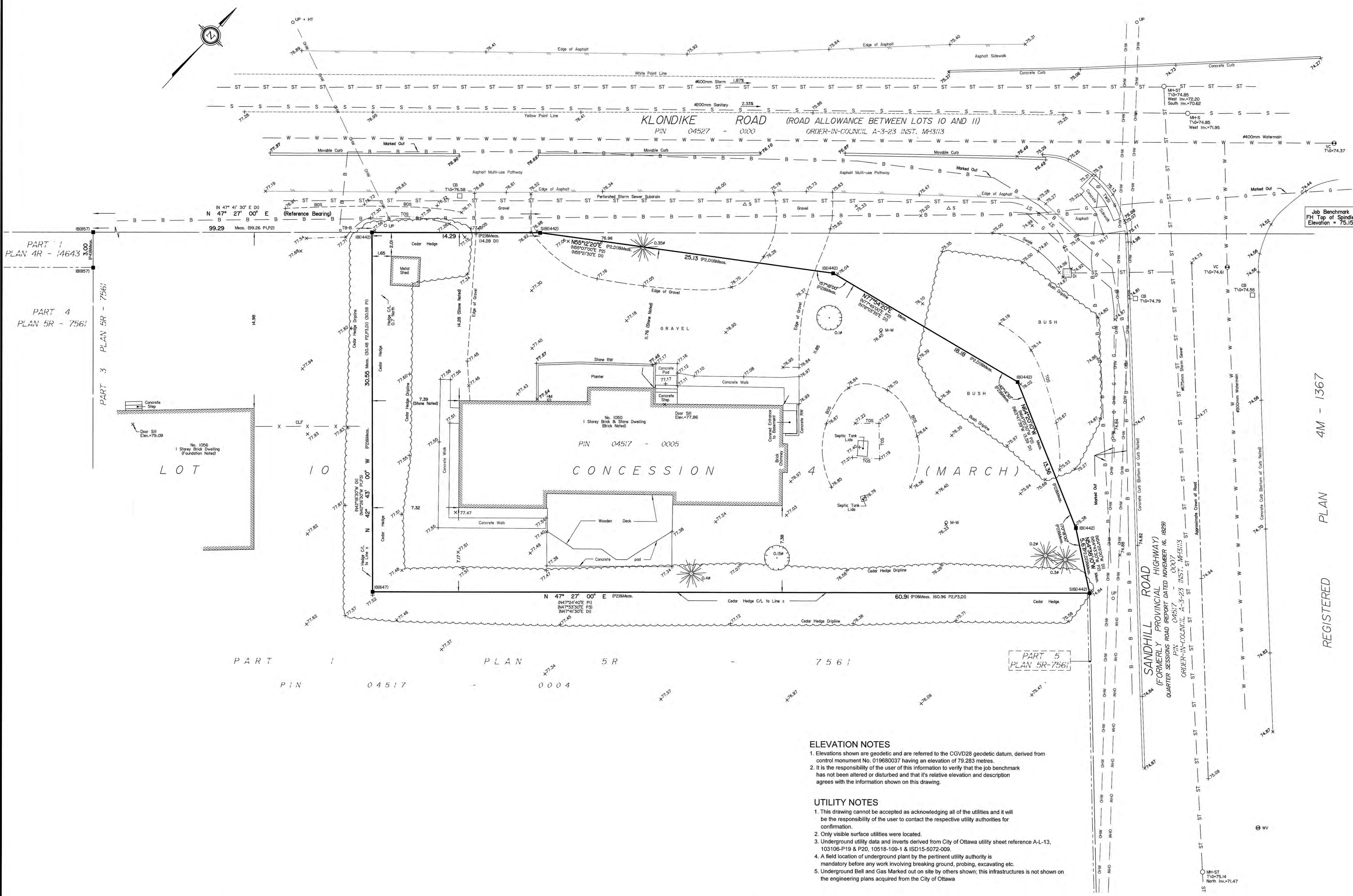

Bearings are grid, derived from Can-Ned 2016 Real Time Network GPS observations, MTM Zone 9 (76°30' West Longitude) NAD-83 (original).
 For bearing comparisons, a rotation of 0°25'00" counter-clockwise was applied to bearings on P1, P2 & P3.

ASSOCIATION OF ONTARIO
 LAND SURVEYORS
 PLAN SUBMISSION FORM
 2136354

THIS PLAN IS NOT VALID UNLESS
 IT IS AN EMBOSSED ORIGINAL
 COPY ISSUED BY THE SURVEYOR
 In accordance with
 Regulation 1028, Section 29 (3).