

NOTE: THIS DRAWING IS THE PROPERTY OF THE ARCHITECT AND MAY NOT BE REPRODUCED OR USED WITHOUT THE EXPRESSED CONSENT OF THE ARCHITECT. THE CONTRACTOR SHALL CHECK AND VERIFY ALL DIMENSIONS AND REPORT ANY OMISSIONS OR DISCREPANCIES TO THE ARCHITECT BEFORE PROCEEDING WITH THE WORK.

DO NOT SCALE THE DRAWINGS

RELEASE / REVISION RECORD

No.	Description	Date
1	ISSUED FOR COORDINATION	22-01-18
2	ISSUED FOR SPC 1ST RESPONSE TO COMMENTS	22-02-04
3	ISSUED FOR CONSULTANT COORDINATION	22-05-27
4	ISSUED FOR SPC 2ND RESPONSE TO COMMENTS	22-06-02

LEGEND AND ABBREVIATIONS

- BUILDING EXIT
- DIRECTIONAL TRAFFIC ARROW
- EXTENT OF BUILDING ABOVE
- EXTENT OF PERMITTED PROJECTIONS ABOVE
- EXISTING ADJACENT BUILDINGS
- CONCRETE SIDEWALK, REFER TO CIVIL, LANDSCAPE
- INTERLOCK, REFER TO CIVIL, LANDSCAPE
- BICYCLE PARKING

PROJECT INFORMATION

PART OF LOT 26 AND 27
CONCESSION 1 (OTTAWA FRONT)
Geographic Township Of Nepean
CITY OF OTTAWA

PROJECT TEAM

ARCHITECT
Chmiel Architects Inc.
109 Bank Street, Suite 200
Ottawa, ON K1P 5N5
Phone: 613-234-3585
Fax: 613-234-6224
Email: info@chmielarchitects.com
http://www.chmielarchitects.com

GEOTECHNICAL
Paterson Group
Head Office: Colonnade RD South,
Ottawa, ON K2E7J5
Phone: 613-228-7381
Fax: 613-226-6344
https://www.patersongroup.ca

MECHANICAL & ELECTRICAL
Modern Niagara
Phone: (613) 591-7505
Fax: (613) 591-1523
https://modernniagara.com

STRUCTURAL
Cleland Jardine Engineering Ltd
200-580 Terry Fox Drive
Kanata, ON K2L 4B9
Phone: 613-591-1533
Fax: 613-591-1703
Email: mail@clelandjardine.com
http://clelandjardine.com

CIVIL
Ainsley Group
2724 Fernton Road,
Ottawa, ON K1T 3T7
Phone: 613-822-1052
Email: ottawa@ainsleygroup.com
https://www.ainsleygroup.com

LANDSCAPE
James B. Lennox & Associates Inc.
3332 Carling Ave,
Ottawa, ON K2H 5A8
Phone: 613-722-5168
Email: jbl@jbla.ca

PROPERTY INFORMATION

SURVEY AND PROPERTY INFORMATION IS TAKEN FROM ANNIS, OSULLIVAN, VOLLEBECK LTD SURVEY DATED 2020-10-26

RICHMOND ROAD AND NEW STREETSCAPE INFORMATION TAKEN FROM EWC DESIGNERS DRAWING NUMBER EJV-SZDRR1-RWY-DWG-3014, STAGE 2 CONFEDERATION LINE EAST, ISSUED FOR FINAL DESIGN DEVELOPMENT 2021-04-15.

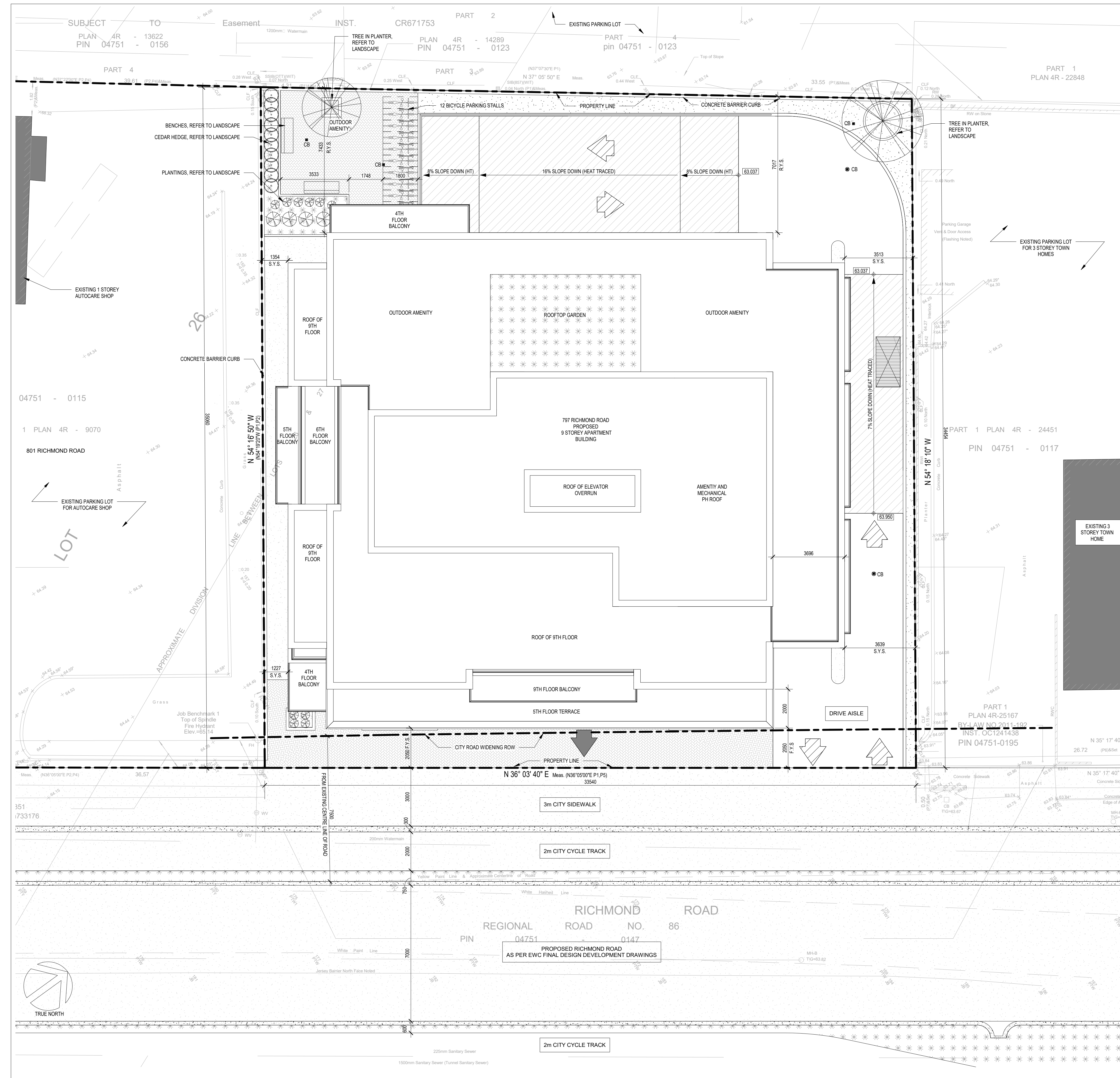

Zoning Information: RM
City of Ottawa Concessionary Zoning By-law 2008-250

Zone Provisions	Required	Proposed	Variance Required	
Traditional Mainstreet Zone (Sections 197 and 198)				
Minimum Lot Area (m ²)	No minimum	1165.47 sq.m.	No	
Minimum Lot Width (m)	No minimum	33.53 m	No	
Maximum Front Yard Setback	2 m, subject to the provisions of subsection 197(8) below	2.05m	Yes	
Interior side yard setbacks	Maximum	3 metres between a non-residential use building or a mixed-use building and another non-residential use building or mixed-use building, except where a driveway is provided, in which case the setback must be a maximum of 6 metres where the driveway leads to a parking area of 20 or more spaces	East Side Yard: 3.5m West Side Yard: 1.2m	No
	Minimum	The maximum setbacks provisions of row (d)(i) above do not apply to the following cases and the following minimum setbacks apply: All other cases - no minimum (maximum setback provisions of row (d)(i) apply in these cases)	East Side Yard: 3.5m West Side Yard: 1.2m	No
Minimum Rear Yard Setback	All Other Cases	No minimum	7m	No
Maximum Building Height (m)	Minimum	6.7 metres for a distance of 20 metres from the front lot line as set out under subsection 197(5) below	31.5m	No
	Maximum	(1) 20 metres but not more than 6 storeys, except where otherwise shown on the zoning map; (2) where the building height is greater than four storeys or 15 metres, at and above the fourth storey or 15 metres whichever is the lesser a building must be setback a minimum of 2 metres more than the provided setback from the front lot line as set out under subsection 197(5) below, and from the corner side lot line	31.5m @ Storeys + Amenity and Mechanical Floors GF - 4TH: 3.05m 5TH - 9TH: 4.05m	Yes
Maximum Floor Space Index	No maximum	NA	NA	No
Minimum Width of Landscaped Area	No minimum, except that where a yard is provided and not used for required driveways, alleys, parking or loading spaces, the whole yard must be landscaped	Whole Yard shall be Landscaped	Whole Yard shall be Landscaped	No
Parking Requirements (Section 100-114)				
Minimum Parking Space Rates (Area Z)	0	35	No	
Visitor Parking (Below Grade, 0.1 spaces per unit after the first twelve units)	4.8	5	No	
Bicycle Parking (0.5 spaces per unit)	60 Units at 0.5 Spaces / Residential Unit 1 Space / 250 sq.m. floor area of Office	30 340 sq.m. / 250 sq.m. = 1 stall	31 (16 outdoors, 15 indoors)	No
Amenity Area (Section 137)				
Minimum Total Amenity Area (sq.m.)	60 Units at 6 sq.m. / Dwelling Unit	360	869	No
Minimum Communal Amenity Area (sq.m.)	50% of Total Amenity	180	369	No
General Information				
Unit Breakdown				
Number of Studio Suites	1			
Number of One Bedroom Suites	23			
Number of One Bedroom + Den	15			
Number of Two Bedroom Suites	21			
TOTAL	60			

OWNER

Dentech Holdings Inc.
797 Richmond Road, Ottawa, ON K2A 0G7
dentech_899@hotmail.com

PROJECT NORTH

MAY NOT BE USED FOR CONSTRUCTION UNLESS SIGNED BY THE ARCHITECT

chmielarchitects
200 - 109 Bank Street
Ottawa, ON K1P 5N5
t (613) 234-3585
f (613) 234-6224

797 RICHMOND APARTMENTS

797 RICHMOND ROAD

PROJECT NO. 20-1881
DRAWN: CG
SCALE: As indicated
CHECKED: RAC
DRAWING TITLE: SITE PLAN

DRAWING NO. SP-001

1 SITE PLAN - ROOF PLAN
SCALE 1:100

SP-001

D07-12-21-0088

#18550

LEGEND AND ABBREVIATIONS

- BUILDING EXIT
- DIRECTIONAL TRAFFIC ARROW
- EXTENT OF BUILDING ABOVE
- EXTENT OF PERMITTED PROJECTIONS ABOVE
- EXISTING ADJACENT BUILDINGS
- CONCRETE SIDEWALK, REFER TO CIVIL, LANDSCAPE
- INTERLOCK, REFER TO CIVIL, LANDSCAPE
- BICYCLE PARKING

F.Y.S. FRONT YARD SETBACK
R.Y.S. REAR YARD SETBACK
S.Y.S. SIDE YARD SETBACK
CB. CATCH BASIN

PROJECT INFORMATION

PART OF LOT 26 AND 27
 CONCESSION 1 (OTTAWA FRONT)
 Geographic Township Of Nepean
 CITY OF OTTAWA

PROJECT TEAM

ARCHITECT
 Chmiel Architects Inc.
 109 Bank Street, Suite 200
 Ottawa, ON K1P 5N5
 Phone: 613-234-3585
 Fax: 613-234-6224
 Email: info@chmielarchitects.com
 http://www.chmielarchitects.com

GEOTECHNICAL
 Paterson Group
 Head Office: Colonnade RD South,
 Ottawa, ON K2E7J5
 Phone: 613-226-7381
 Fax: 613-226-6344
 https://www.patersongroup.ca

MECHANICAL & ELECTRICAL
 Modern Niagara
 Phone: (613) 591-1505
 Fax: (613) 591-1523
 https://www.modernniagara.com

STRUCTURAL
 Cleland Jardine Engineering Ltd
 200-580 Terry Fox Drive
 Kanata, ON K2L 4S9
 Phone: 613-591-1533
 Fax: 613-591-1703
 Email: mail@clelandjardine.com
 http://clelandjardine.com

CIVIL
 Ainley Group
 2724 Fenton Road,
 Ottawa, ON K1T 3T7
 Phone: 613-822-1052
 Email: ottawa@ainleygroup.com
 https://www.ainleygroup.com

LANDSCAPE
 James B. Lennox & Associates Inc.
 3332 Carling Ave.
 Ottawa, ON K2H 5A8
 Phone: 613-722-5168
 Email: jbl@jbla.ca

PROPERTY INFORMATION

SURVEY AND PROPERTY INFORMATION IS TAKEN FROM ANNIS, OSULLIVAN, VOLLEBECK LTD SURVEY DATED 2020-10-26

RICHMOND ROAD AND NEW STREETSCAPE INFORMATION TAKEN FROM EWC DESIGNERS DRAWING NUMBER EJV-S2RDR1-RWY-DWG-3014, STAGE 2 CONFEDERATION LINE EAST, ISSUED FOR FINAL DESIGN DEVELOPMENT 2021-04-15.

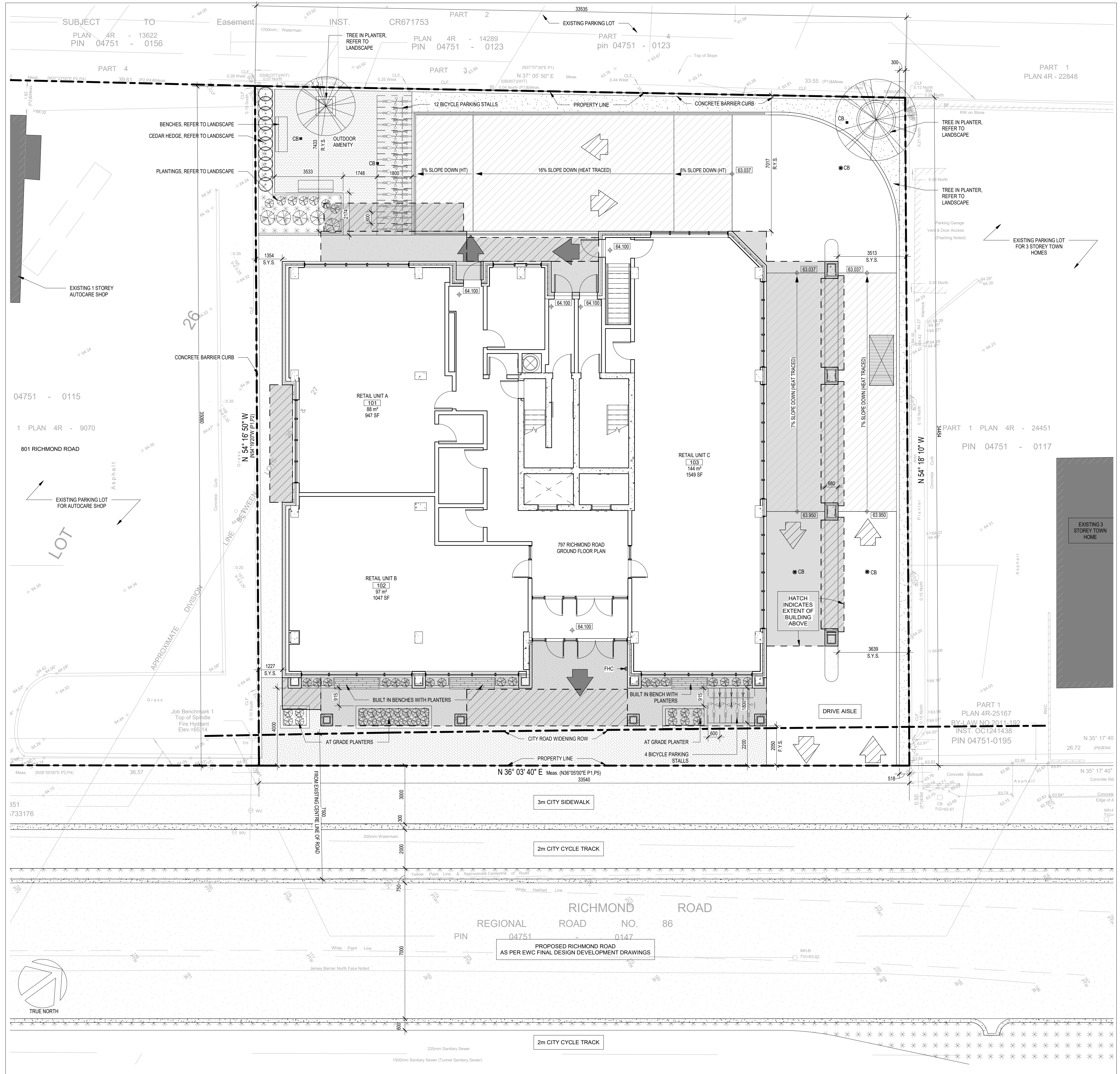

NOTE: THIS DRAWING IS THE PROPERTY OF THE ARCHITECT AND MAY NOT BE REPRODUCED OR USED WITHOUT THE EXPRESSED CONSENT OF THE ARCHITECT. THE CONTRACTOR SHALL CHECK AND VERIFY ALL DIMENSIONS AND REPORT ANY OMISSIONS OR DISCREPANCIES TO THE ARCHITECT BEFORE PROCEEDING WITH THE WORK.

DO NOT SCALE THE DRAWINGS

RELEASE / REVISION RECORD

No.	Description	Date
3	ISSUED FOR COORDINATION	21-04-05
4	ISSUED FOR COORDINATION	21-04-14
5	ISSUED FOR COORDINATION	21-05-05
6	RESUBMITTED FOR COORDINATION	21-05-05
7	ISSUED FOR COORDINATION	21-05-12
8	ISSUED FOR SITE PLAN CONTROL	21-06-09
9	ISSUED FOR COORDINATION	22-01-18
10	ISSUED FOR SPC 1ST RESPONSE TO COMMENTS	22-02-04
11	ISSUED FOR CONSULTANT COORDINATION	22-05-27
12	ISSUED FOR SPC 2ND RESPONSE TO COMMENTS	22-06-02

OWNER

Dentech Holdings Inc.
 797 Richmond Road, Ottawa, ON K2A 0G7
 dentech_899@hotmail.com

PROJECT NORTH

MAY NOT BE USED FOR CONSTRUCTION UNLESS SIGNED BY THE ARCHITECT

chmielarchitects
 200 - 109 Bank Street
 Ottawa, ON K1P 5N5
 t (613) 234-3585
 f (613) 234-6224

797 RICHMOND APARTMENTS

797 RICHMOND ROAD

PROJECT NO. 20-1881 DRAWN CG
 SCALE As indicated CHECKED RAC

DRAWING TITLE
SITE PLAN AT GROUND FLOOR

DRAWING NO.
SP-002

D07-12-21-0088

NOTE: THIS DRAWING IS THE PROPERTY OF THE ARCHITECT AND MAY NOT BE REPRODUCED OR USED WITHOUT THE EXPRESSED CONSENT OF THE ARCHITECT. THE CONTRACTOR SHALL CHECK AND VERIFY ALL DIMENSIONS AND REPORT ANY OMISSIONS OR DISCREPANCIES TO THE ARCHITECT BEFORE PROCEEDING WITH THE WORK.

DO NOT SCALE THE DRAWINGS

RELEASE / REVISION RECORD

No.	Description	Date
1	ISSUED FOR SPC 1ST RESPONSE TO COMMENTS	22-02-04
2	ISSUED FOR CONSULTANT COORDINATION	22-05-27
3	ISSUED FOR SPC 2ND RESPONSE TO COMMENTS	22-06-02

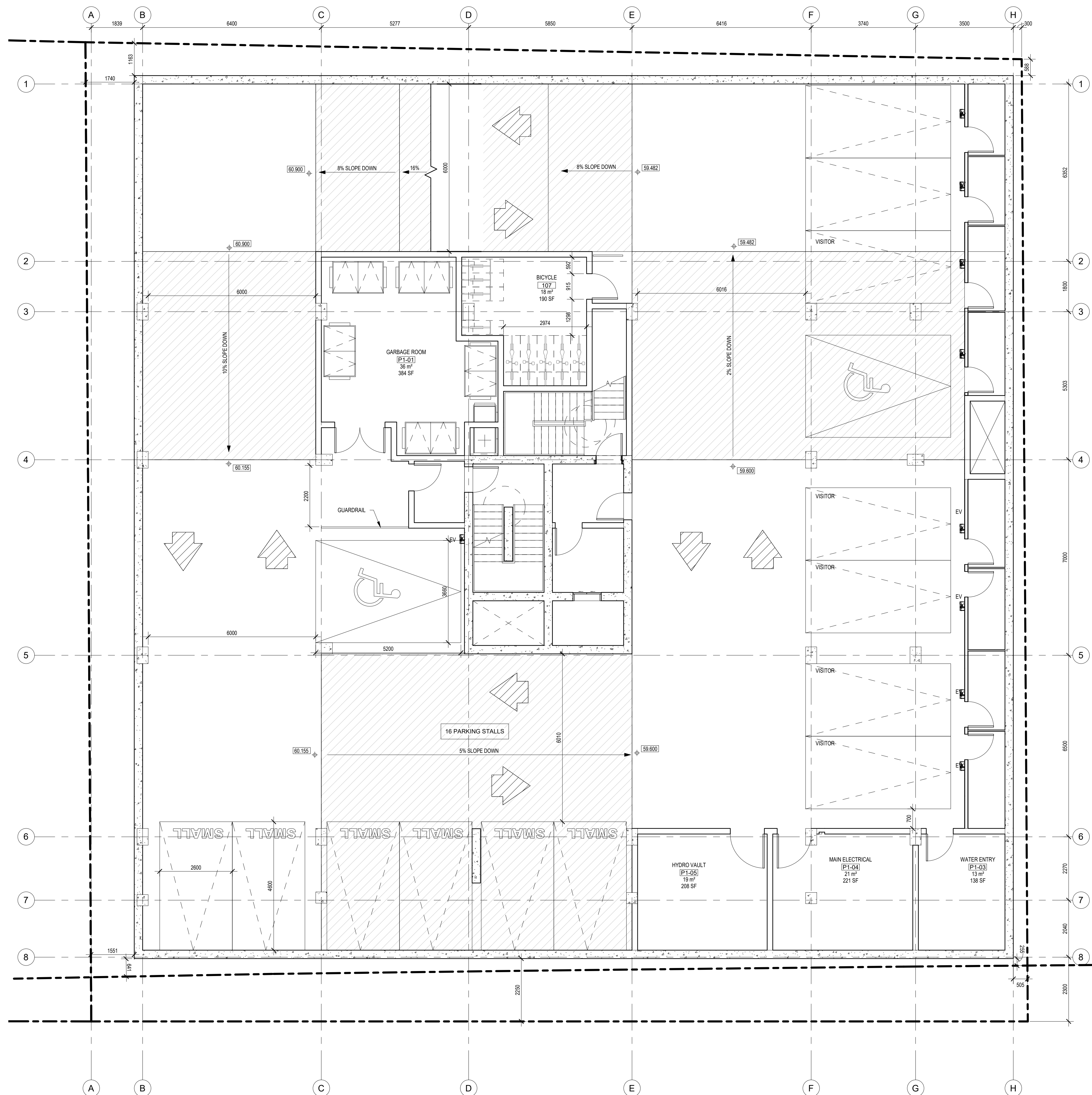

1 P1 FLOOR PLAN
A-100-1 SCALE: 1 : 75

OWNER
Dentech Holdings Inc.
797 Richmond Road, Ottawa, ON K2A 0G7
dentech_899@hotmail.com

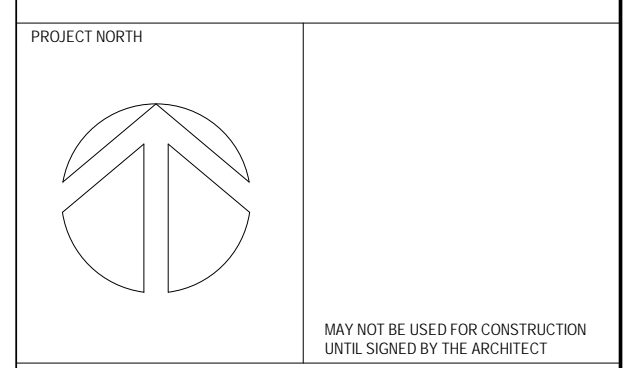

chmielarchitects
200 - 109 Bank Street
Ottawa, ON K1P 5N5
t (613) 234-3585
f (613) 234-6224

797 RICHMOND APARTMENTS
797 RICHMOND ROAD
PROJECT NO. 20-1881 DRAWN AP
SCALE 1 : 75 CHECKED RAC
DRAWING TITLE
P1 FLOOR PLAN

DRAWING NO.
A-100-1

D07-12-21-0088

NOTE: THIS DRAWING IS THE PROPERTY OF THE ARCHITECT AND MAY NOT BE REPRODUCED OR USED WITHOUT THE EXPRESSED CONSENT OF THE ARCHITECT. THE CONTRACTOR SHALL CHECK AND VERIFY ALL DIMENSIONS AND REPORT ANY OMISSIONS OR DISCREPANCIES TO THE ARCHITECT BEFORE PROCEEDING WITH THE WORK.

DO NOT SCALE THE DRAWINGS

RELEASE / REVISION RECORD

No.	Description	Date
1	ISSUED FOR SPC 1ST RESPONSE TO COMMENTS	22-02-04
2	ISSUED FOR CONSULTANT COORDINATION	22-05-27
3	ISSUED FOR SPC 2ND RESPONSE TO COMMENTS	22-06-02

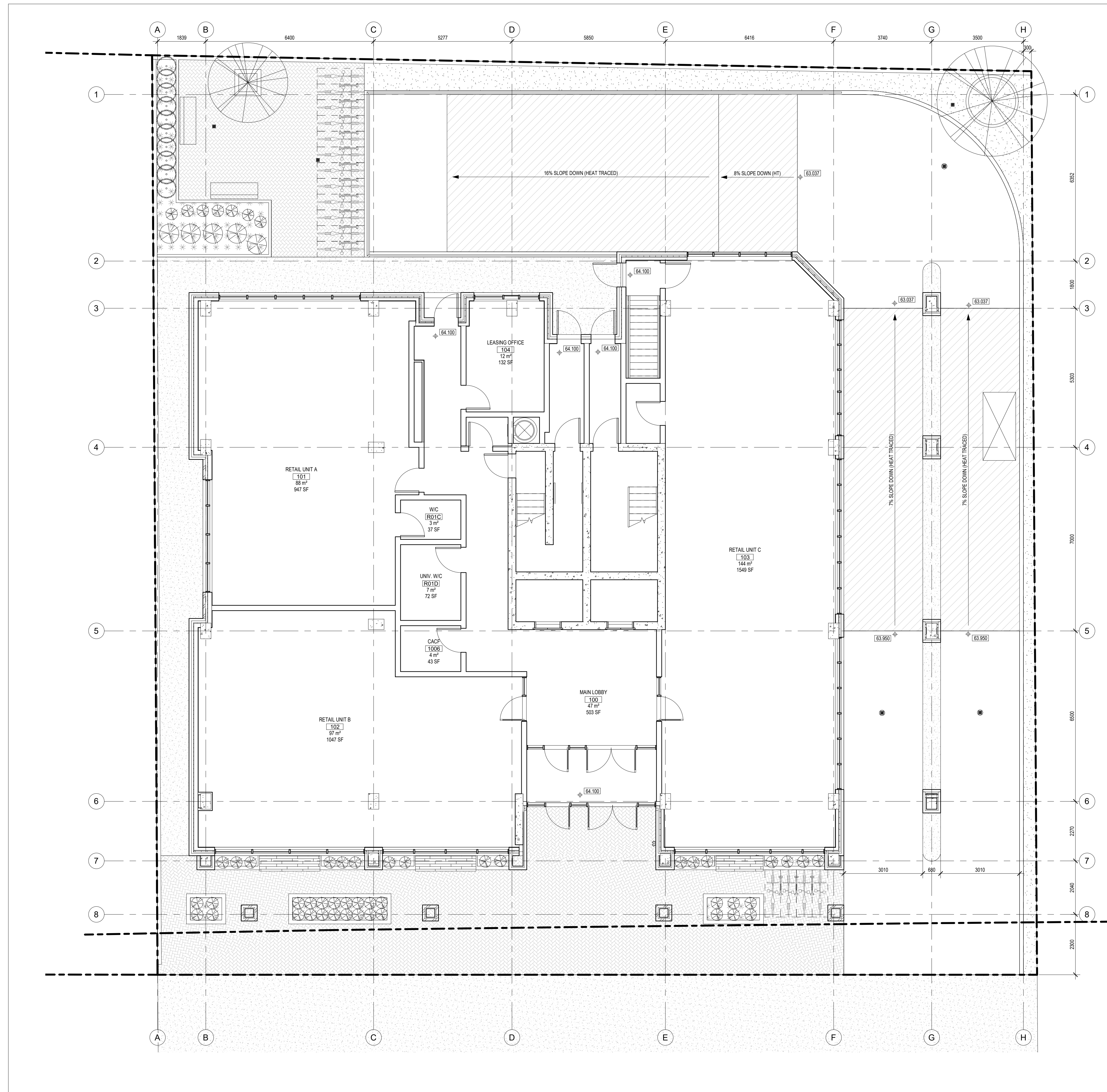

OWNER
Dentech Holdings Inc.
797 Richmond Road, Ottawa, ON K2A 0G7
dentech_899@hotmail.com

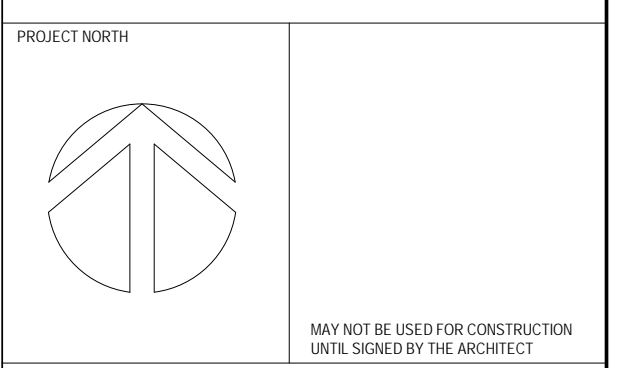

chmielarchitects
200 - 109 Bank Street
Ottawa, ON K1P 5N5
t (613) 234-3585
f (613) 234-6224

797 RICHMOND APARTMENTS

797 RICHMOND ROAD

PROJECT NO. 20-1881 DRAWN AP

SCALE 1:75 CHECKED RAC

DRAWING TITLE
GROUND FLOOR PLAN

DRAWING NO.

1 GROUND FLOOR PLAN
A-101 SCALE: 1:75

A-101

D07-12-21-0088

#18550

NOTE: THIS DRAWING IS THE PROPERTY OF THE ARCHITECT AND MAY NOT BE REPRODUCED OR USED WITHOUT THE EXPRESSED CONSENT OF THE ARCHITECT. THE CONTRACTOR SHALL CHECK AND VERIFY ALL DIMENSIONS AND REPORT ANY OMISSIONS OR DISCREPANCIES TO THE ARCHITECT BEFORE PROCEEDING WITH THE WORK.

DO NOT SCALE THE DRAWINGS

RELEASE / REVISION RECORD

No.	Description	Date
1	ISSUED FOR SPC 1ST RESPONSE TO COMMENTS	22-02-04
2	ISSUED FOR SPC 2ND RESPONSE TO COMMENTS	22-06-02

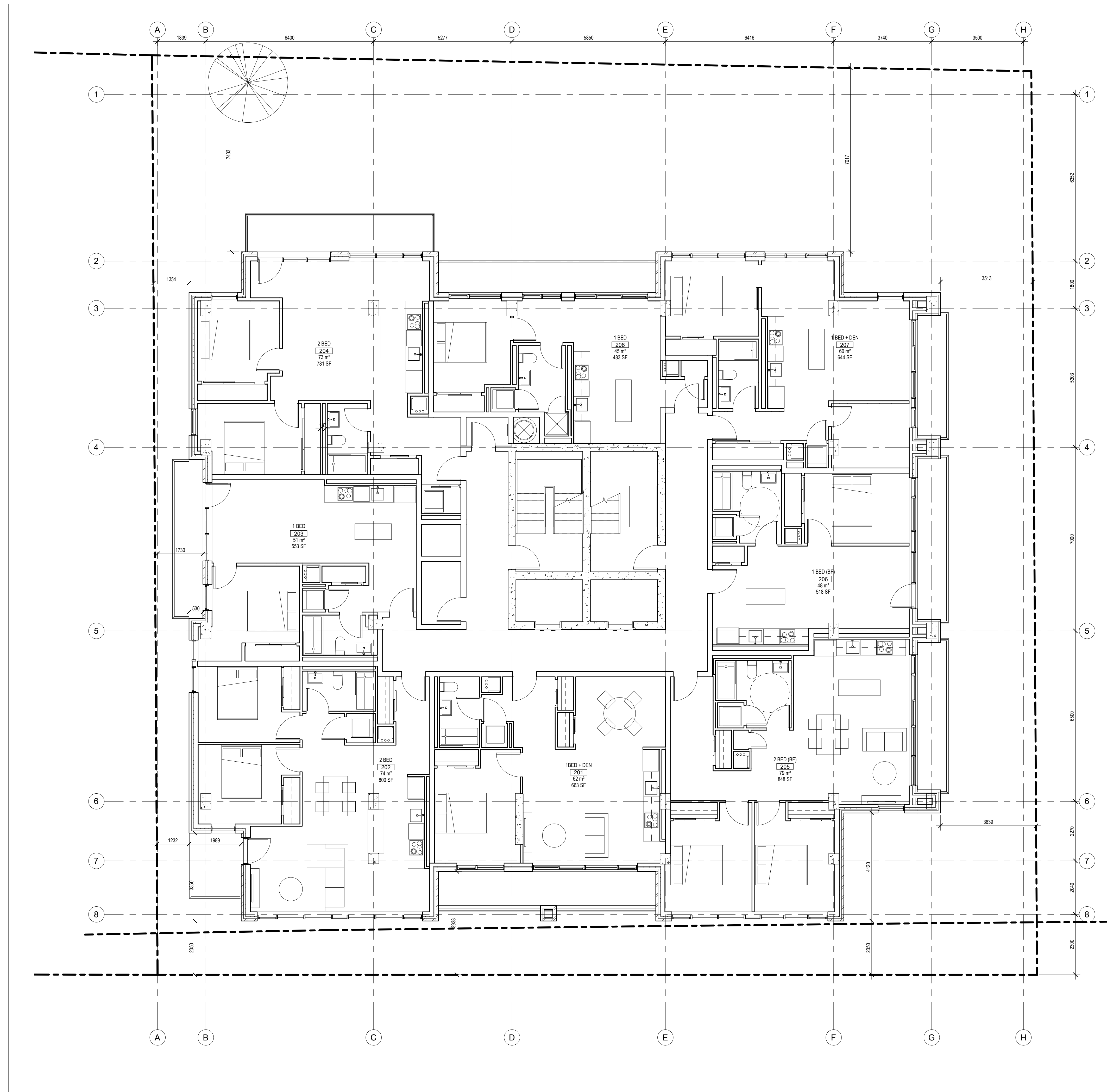

OWNER
Dentech Holdings Inc.
797 Richmond Road, Ottawa, ON K2A 0G7
dentech_899@hotmail.com

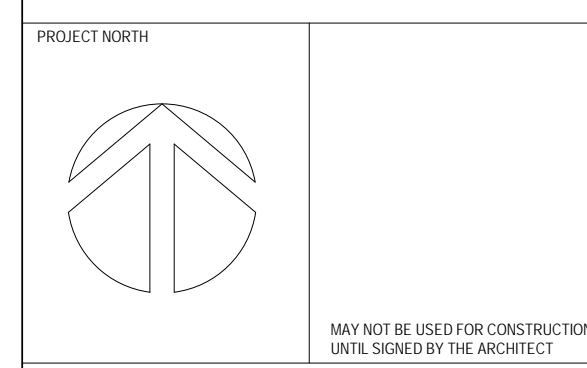

chmielarchitects
200 - 109 Bank Street
Ottawa, ON K1P 5N5
t (613) 234-3585
f (613) 234-6224

797 RICHMOND APARTMENTS
797 RICHMOND ROAD

PROJECT NO. **20-1881** DRAWN **AP**
SCALE **1 : 75** CHECKED **RAC**

DRAWING TITLE
2ND FLOOR PLAN

DRAWING NO.

1 2ND FLOOR PLAN
A-102 SCALE: 1 : 75

A-102

D07-12-21-0088

#18550

NOTE: THIS DRAWING IS THE PROPERTY OF THE ARCHITECT AND MAY NOT BE REPRODUCED OR USED WITHOUT THE EXPRESSED CONSENT OF THE ARCHITECT. THE CONTRACTOR SHALL CHECK AND VERIFY ALL DIMENSIONS AND REPORT ANY OMISSIONS OR DISCREPANCIES TO THE ARCHITECT BEFORE PROCEEDING WITH THE WORK.

DO NOT SCALE THE DRAWINGS

RELEASE / REVISION RECORD

No.	Description	Date
1	ISSUED FOR SPC 1ST RESPONSE TO COMMENTS	22-02-04
2	ISSUED FOR SPC 2ND RESPONSE TO COMMENTS	22-06-02

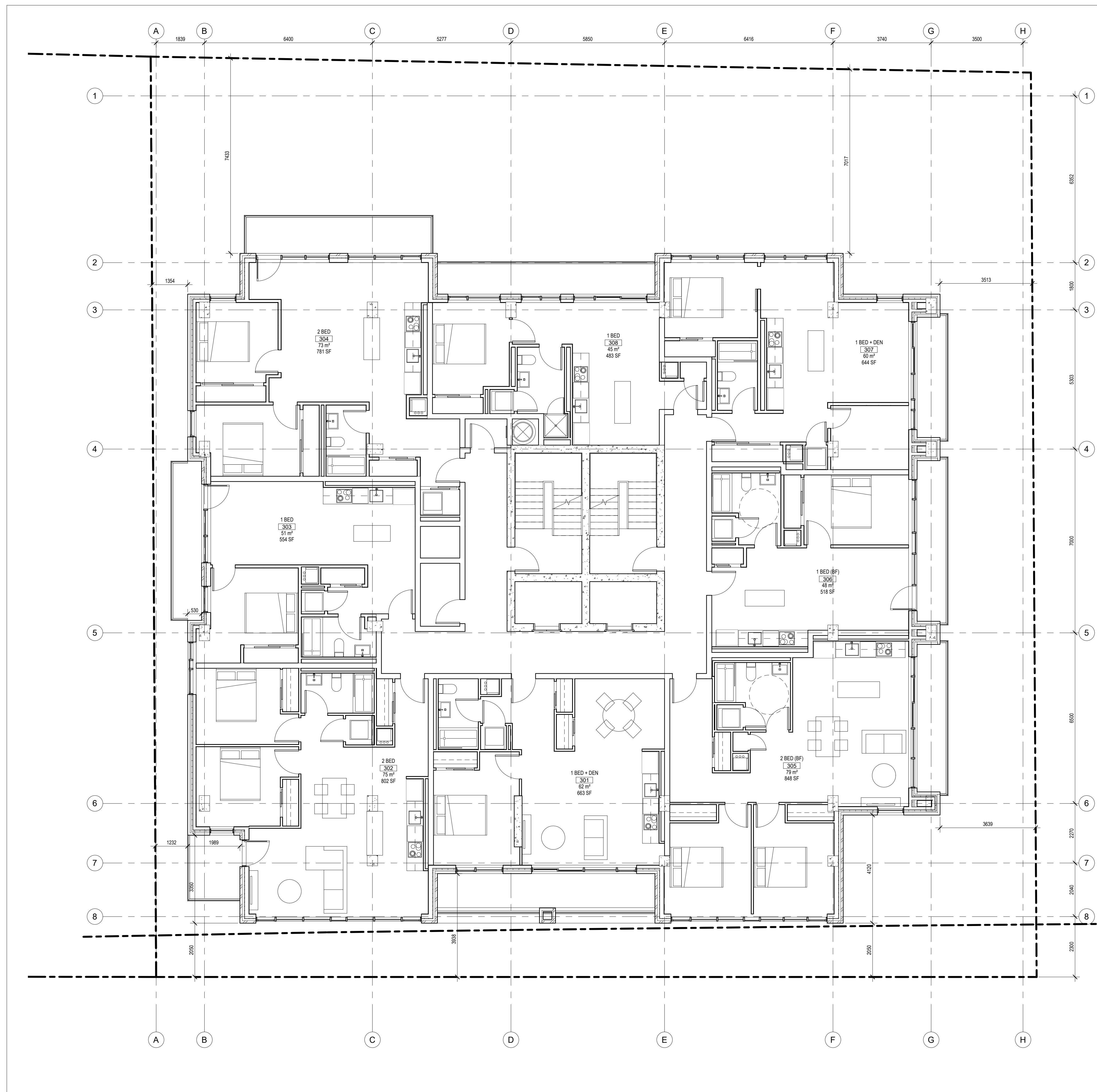

1 3RD FLOOR PLAN
A-103 SCALE: 1:75

OWNER

Dentech Holdings Inc.
797 Richmond Road, Ottawa, ON K2A 0G7
dentech_899@hotmail.com

PROJECT NORTH

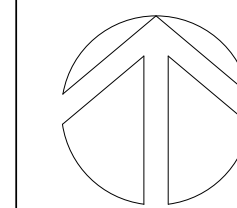

MAY NOT BE USED FOR CONSTRUCTION UNTIL SIGNED BY THE ARCHITECT

chmielarchitects

200 - 109 Bank Street
Ottawa, ON K1P 5N5
t (613) 234-3585
f (613) 234-6224

797 RICHMOND APARTMENTS

797 RICHMOND ROAD

PROJECT NO.
20-1881

DRAWN
AP

SCALE
1:75

CHECKED
RAC

DRAWING TITLE

3RD FLOOR PLAN

DRAWING NO.

A-103

D07-12-21-0088
#18550

NOTE: THIS DRAWING IS THE PROPERTY OF THE ARCHITECT AND MAY NOT BE REPRODUCED OR USED WITHOUT THE EXPRESSED CONSENT OF THE ARCHITECT. THE CONTRACTOR SHALL CHECK AND VERIFY ALL DIMENSIONS AND REPORT ANY OMISSIONS OR DISCREPANCIES TO THE ARCHITECT BEFORE PROCEEDING WITH THE WORK.

DO NOT SCALE THE DRAWINGS

RELEASE / REVISION RECORD

No.	Description	Date
1	ISSUED FOR SPC 1ST RESPONSE TO COMMENTS	22-02-04
2	ISSUED FOR SPC 2ND RESPONSE TO COMMENTS	22-06-02

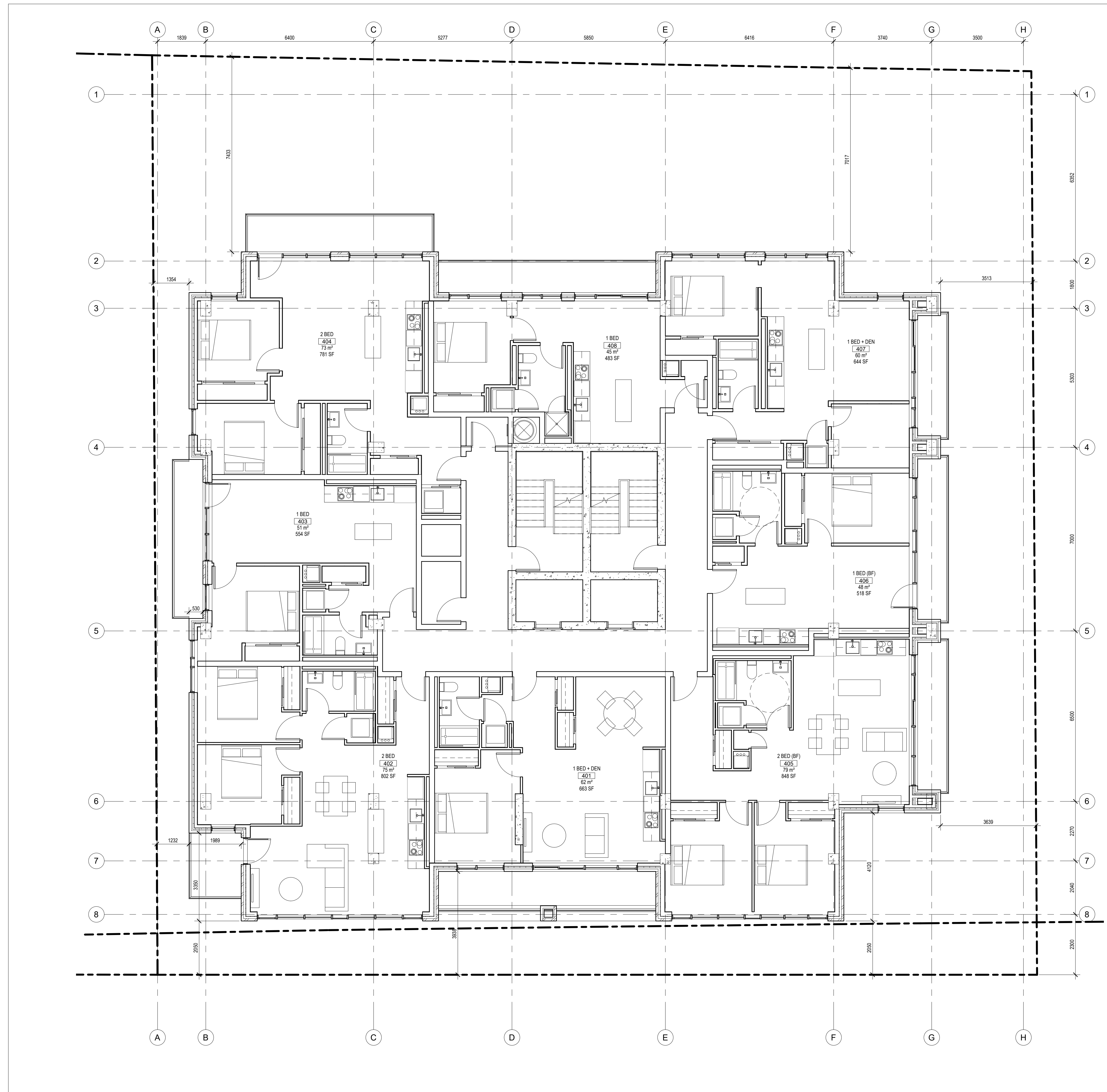

OWNER
Dentech Holdings Inc.
797 Richmond Road, Ottawa, ON K2A 0G7
dentech_899@hotmail.com

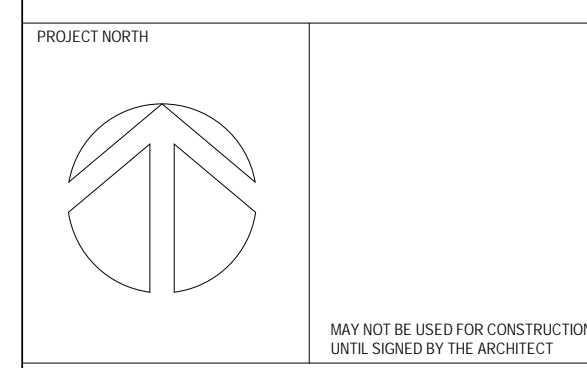

chmielarchitects
200 - 109 Bank Street
Ottawa, ON K1P 5N5
t (613) 234-3585
f (613) 234-6224

797 RICHMOND APARTMENTS
797 RICHMOND ROAD

PROJECT NO. 20-1881 DRAWN AP
SCALE 1:75 CHECKED RAC

DRAWING TITLE
4TH FLOOR PLAN

1 4TH FLOOR PLAN
A-104 SCALE: 1:75

A-104

D07-12-21-0088

#18550

NOTE: THIS DRAWING IS THE PROPERTY OF THE ARCHITECT AND MAY NOT BE REPRODUCED OR USED WITHOUT THE EXPRESSED CONSENT OF THE ARCHITECT. THE CONTRACTOR SHALL CHECK AND VERIFY ALL DIMENSIONS AND REPORT ANY OMISSIONS OR DISCREPANCIES TO THE ARCHITECT BEFORE PROCEEDING WITH THE WORK.

DO NOT SCALE THE DRAWINGS

RELEASE / REVISION RECORD

No.	Description	Date
1	ISSUED FOR SPC 1ST RESPONSE TO COMMENTS	22-02-04
2	ISSUED FOR SPC 2ND RESPONSE TO COMMENTS	22-06-02

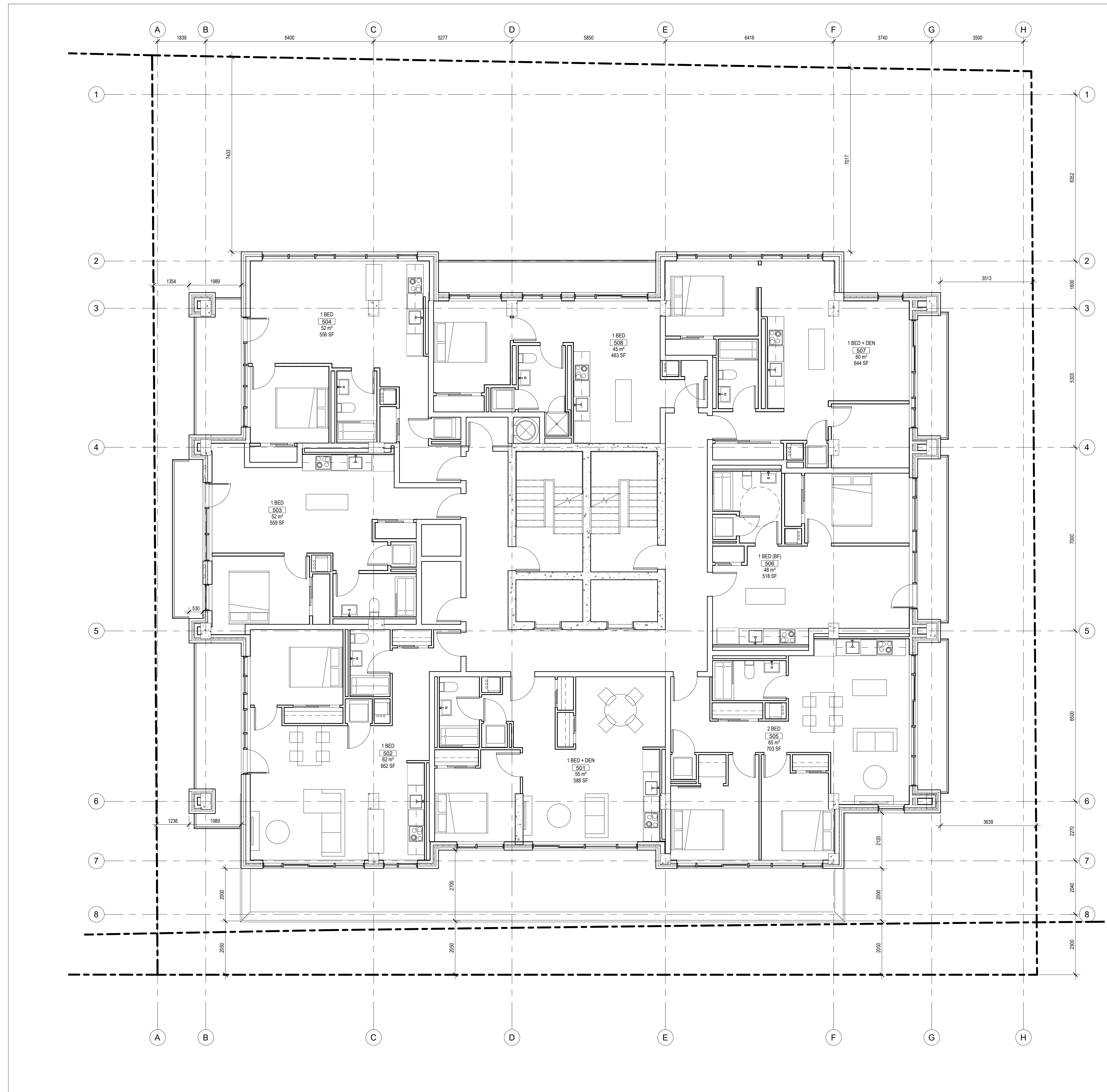

1 5TH FLOOR PLAN
A-105 SCALE: 1 : 75

OWNER
Dentech Holdings Inc.
797 Richmond Road, Ottawa, ON K2A 0G7
dentech_899@hotmail.com

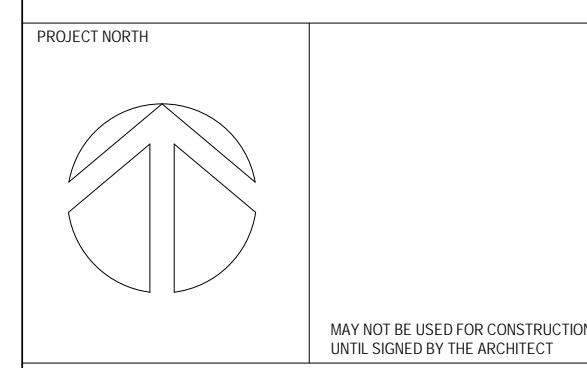

chmielarchitects
200 - 109 Bank Street
Ottawa, ON K1P 5N5
t (613) 234-3585
f (613) 234-6224

797 RICHMOND APARTMENTS
797 RICHMOND ROAD
PROJECT NO. 20-1881 DRAWN AP
SCALE 1 : 75 CHECKED RAC
DRAWING TITLE
5TH FLOOR PLAN

DRAWING NO.
A-105

D07-12-21-0088

#18550

NOTE: THIS DRAWING IS THE PROPERTY OF THE ARCHITECT AND MAY NOT BE REPRODUCED OR USED WITHOUT THE EXPRESSED CONSENT OF THE ARCHITECT. THE CONTRACTOR SHALL CHECK AND VERIFY ALL DIMENSIONS AND REPORT ANY OMISSIONS OR DISCREPANCIES TO THE ARCHITECT BEFORE PROCEEDING WITH THE WORK.

DO NOT SCALE THE DRAWINGS

RELEASE / REVISION RECORD

No.	Description	Date
1	ISSUED FOR SPC 1ST RESPONSE TO COMMENTS	22-02-04
2	ISSUED FOR SPC 2ND RESPONSE TO COMMENTS	22-06-02

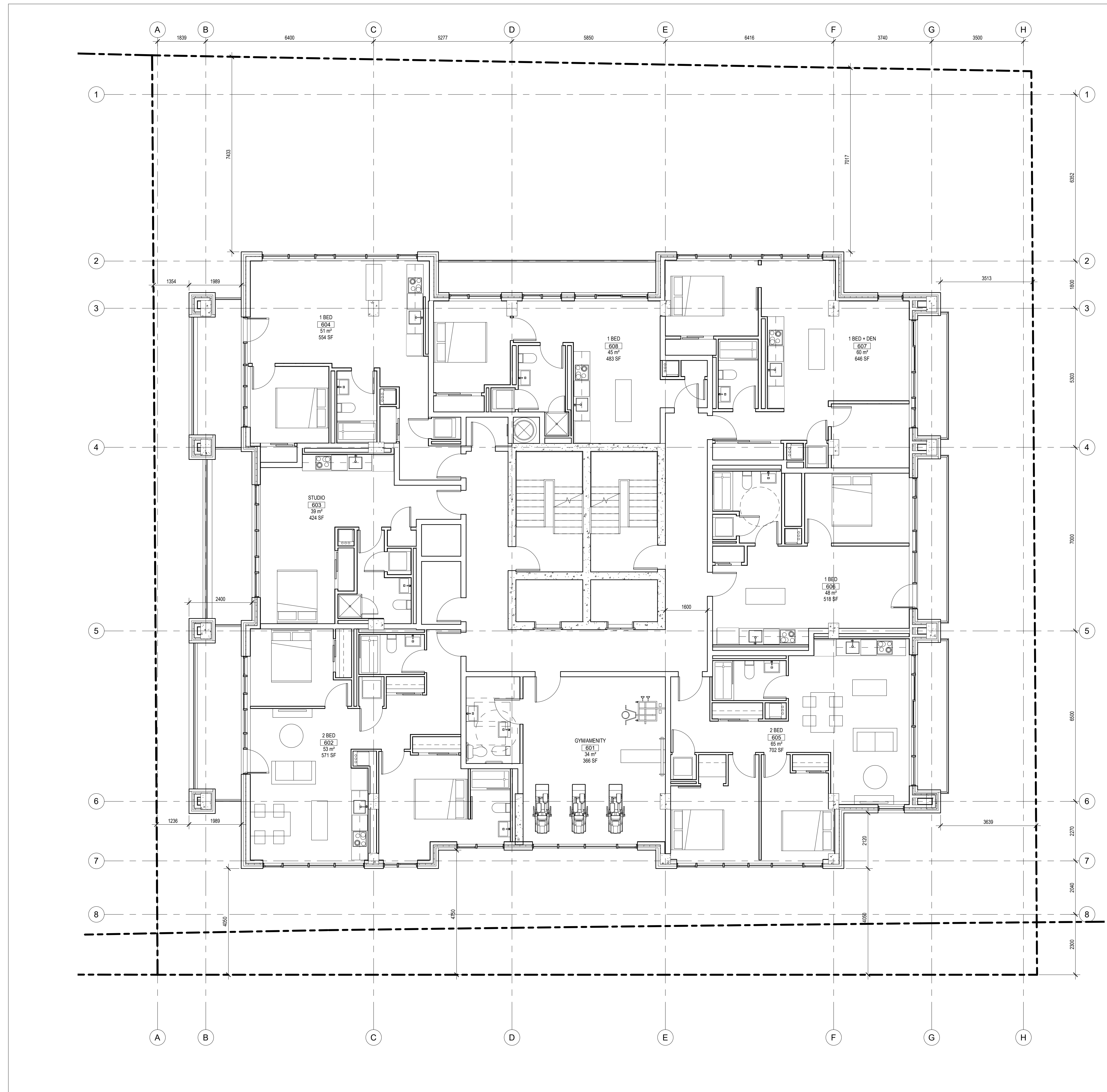

OWNER
Dentech Holdings Inc.
797 Richmond Road, Ottawa, ON K2A 0G7
dentech_899@hotmail.com

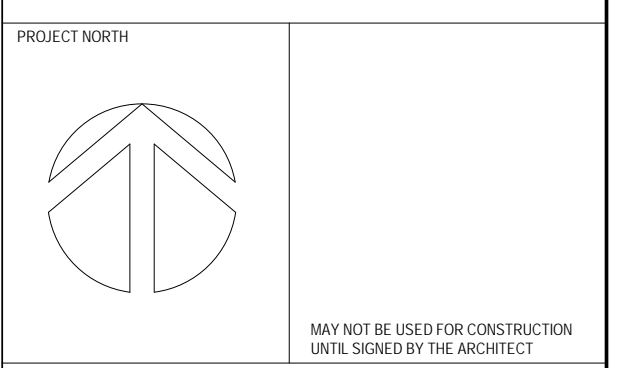

chmielarchitects
200 - 109 Bank Street
Ottawa, ON K1P 5N5
t (613) 234-3585
f (613) 234-6224

797 RICHMOND APARTMENTS
797 RICHMOND ROAD

PROJECT NO. 20-1881 DRAWN AP
SCALE 1:75 CHECKED RAC

DRAWING TITLE
6TH FLOOR PLAN

DRAWING NO.
A-106

1 6TH FLOOR PLAN
A-106 SCALE: 1:75

NOTE: THIS DRAWING IS THE PROPERTY OF THE ARCHITECT AND MAY NOT BE REPRODUCED OR USED WITHOUT THE EXPRESSED CONSENT OF THE ARCHITECT. THE CONTRACTOR SHALL CHECK AND VERIFY ALL DIMENSIONS AND REPORT ANY OMISSIONS OR DISCREPANCIES TO THE ARCHITECT BEFORE PROCEEDING WITH THE WORK.

DO NOT SCALE THE DRAWINGS

RELEASE / REVISION RECORD

No.	Description	Date
1	ISSUED FOR SPC 1ST RESPONSE TO COMMENTS	22-02-04
2	ISSUED FOR SPC 2ND RESPONSE TO COMMENTS	22-06-02

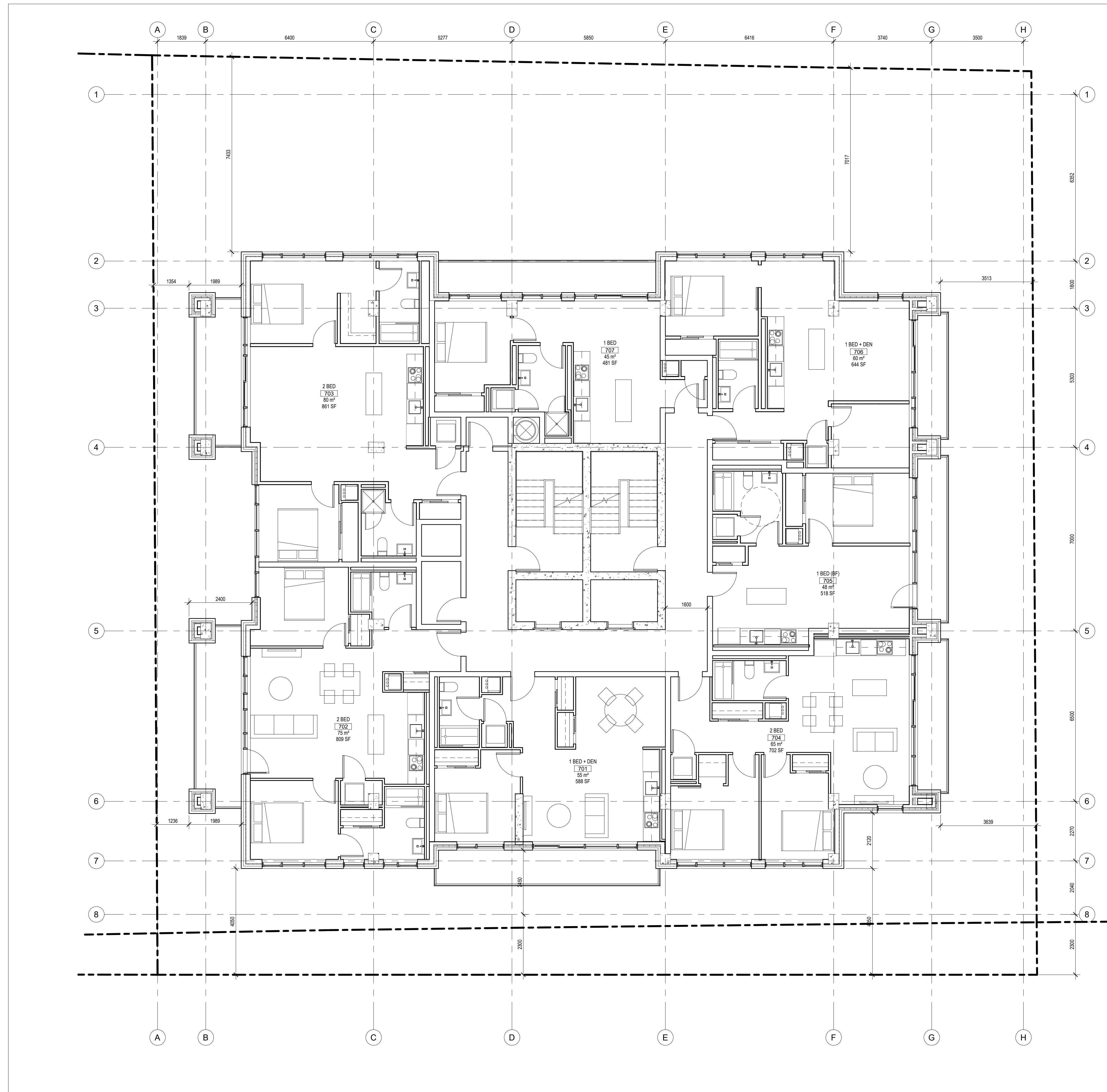

OWNER
Dentech Holdings Inc.
797 Richmond Road, Ottawa, ON K2A 0G7
dentech_899@hotmail.com

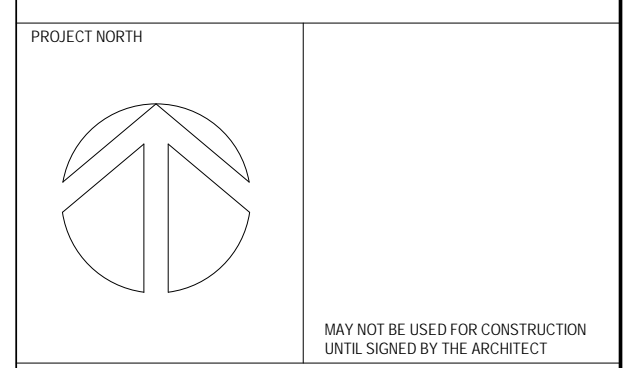

chmielarchitects
200 - 109 Bank Street
Ottawa, ON K1P 5N5
t (613) 234-3585
f (613) 234-6224

797 RICHMOND APARTMENTS
797 RICHMOND ROAD
PROJECT NO. 20-1881 DRAWN AP
SCALE 1:75 CHECKED RAC
DRAWING TITLE
7TH FLOOR PLAN

1 7TH FLOOR PLAN
A-107 SCALE: 1:75

A-107

D07-12-21-0088

NOTE: THIS DRAWING IS THE PROPERTY OF THE ARCHITECT AND MAY NOT BE REPRODUCED OR USED WITHOUT THE EXPRESSED CONSENT OF THE ARCHITECT. THE CONTRACTOR SHALL CHECK AND VERIFY ALL DIMENSIONS AND REPORT ANY OMISSIONS OR DISCREPANCIES TO THE ARCHITECT BEFORE PROCEEDING WITH THE WORK.

DO NOT SCALE THE DRAWINGS

RELEASE / REVISION RECORD

No.	Description	Date
1	ISSUED FOR SFC 1ST RESPONSE TO COMMENTS	22-02-04
2	ISSUED FOR SFC 2ND RESPONSE TO COMMENTS	22-06-02

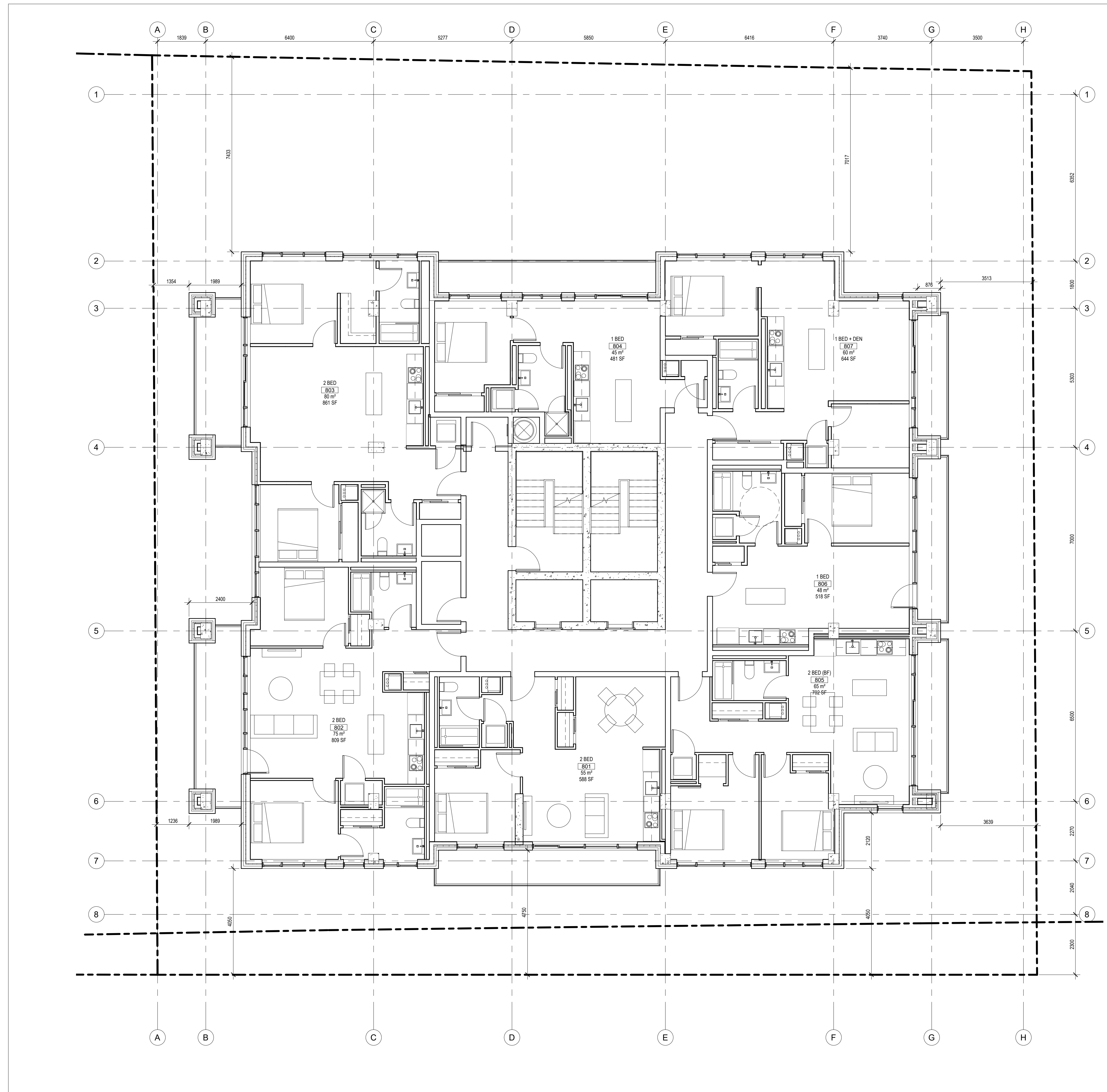

OWNER
Dentech Holdings Inc.
797 Richmond Road, Ottawa, ON K2A 0G7
dentech_899@hotmail.com

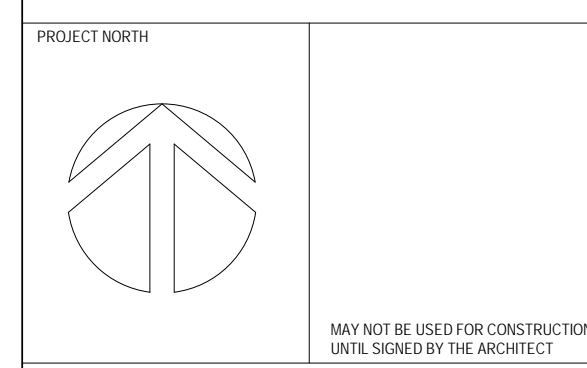

chmielarchitects
200 - 109 Bank Street
Ottawa, ON K1P 5N5
t (613) 234-3585
f (613) 234-6224

797 RICHMOND APARTMENTS

797 RICHMOND ROAD
PROJECT NO. 20-1881 DRAWN AP
SCALE 1:75 CHECKED RAC
DRAWING TITLE

8TH FLOOR PLAN

1 8TH FLOOR PLAN
A-108 SCALE: 1:75

A-108

D07-12-21-0088

NOTE: THIS DRAWING IS THE PROPERTY OF THE ARCHITECT AND MAY NOT BE REPRODUCED OR USED WITHOUT THE EXPRESSED CONSENT OF THE ARCHITECT. THE CONTRACTOR SHALL CHECK AND VERIFY ALL DIMENSIONS AND REPORT ANY OMISSIONS OR DISCREPANCIES TO THE ARCHITECT BEFORE PROCEEDING WITH THE WORK.

DO NOT SCALE THE DRAWINGS

RELEASE / REVISION RECORD

No.	Description	Date
1	ISSUED FOR SPC 1ST RESPONSE TO COMMENTS	22-02-04
2	ISSUED FOR SPC 2ND RESPONSE TO COMMENTS	22-06-02

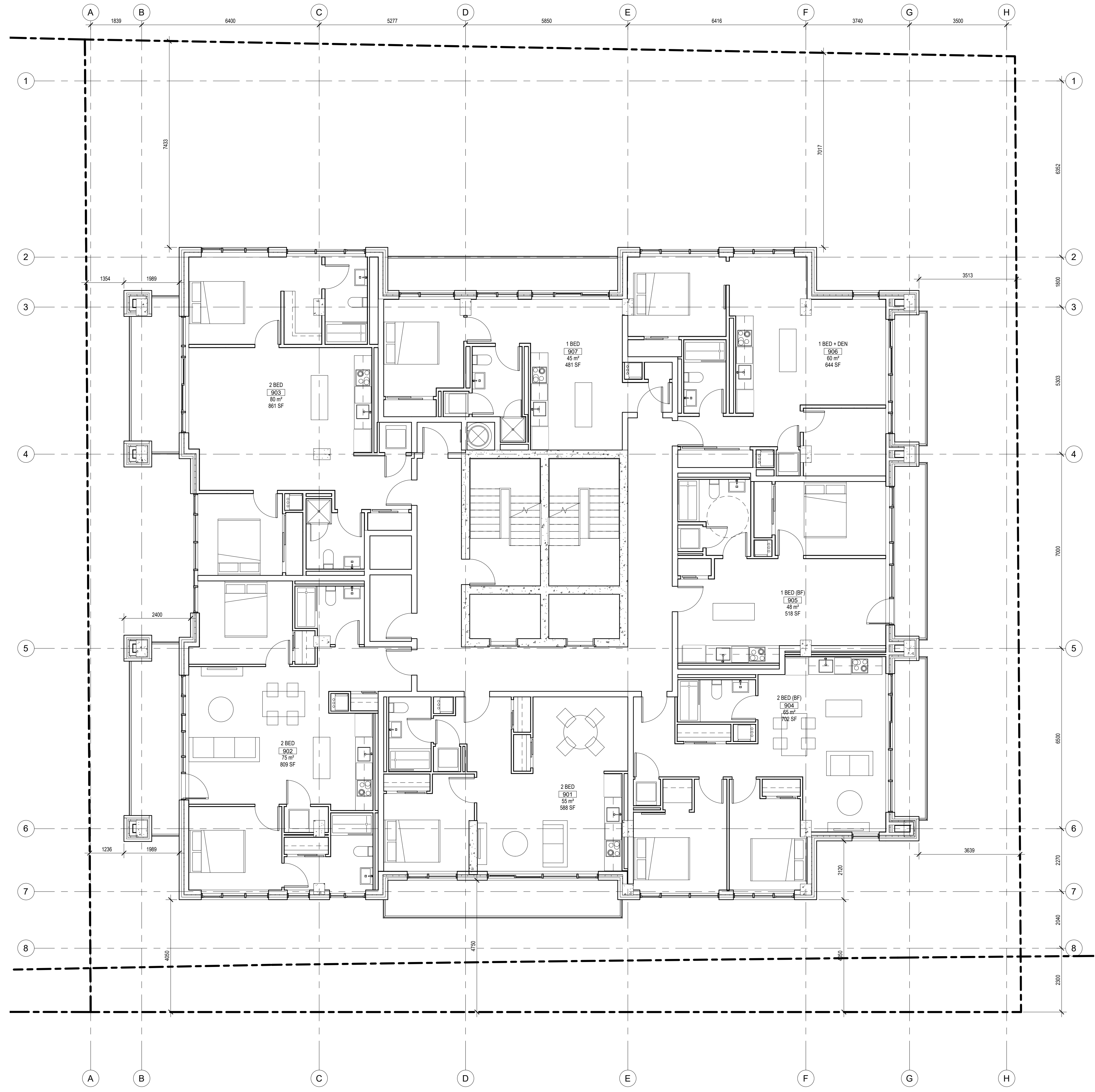

OWNER
Dentech Holdings Inc.
797 Richmond Road, Ottawa, ON K2A 0G7
dentech_899@hotmail.com

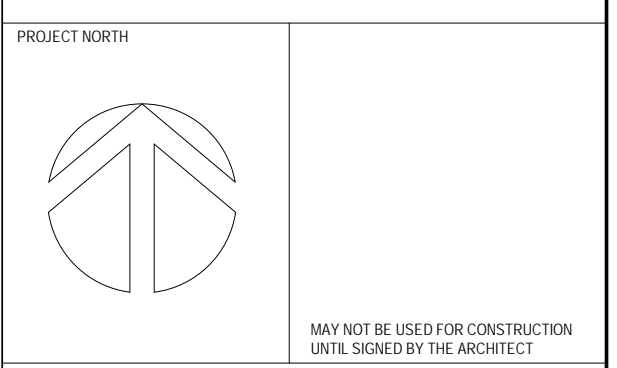

chmielarchitects
200 - 109 Bank Street
Ottawa, ON K1P 5N5
t (613) 234-3585
f (613) 234-6224

797 RICHMOND APARTMENTS

797 RICHMOND ROAD
PROJECT NO. 20-1881 DRAWN AP
SCALE 1:75 CHECKED RAC

9TH FLOOR PLAN

DRAWING NO.

1 9TH FLOOR PLAN
A-109 SCALE: 1:75

A-109

D07-12-21-0088

NOTE: THIS DRAWING IS THE PROPERTY OF THE ARCHITECT AND MAY NOT BE REPRODUCED OR USED WITHOUT THE EXPRESSED CONSENT OF THE ARCHITECT. THE CONTRACTOR SHALL CHECK AND VERIFY ALL DIMENSIONS AND REPORT ANY OMISSIONS OR DISCREPANCIES TO THE ARCHITECT BEFORE PROCEEDING WITH THE WORK.

DO NOT SCALE THE DRAWINGS

RELEASE / REVISION RECORD

No.	Description	Date
1	ISSUED FOR SPC 1ST RESPONSE TO COMMENTS	22-02-04
2	ISSUED FOR SPC 2ND RESPONSE TO COMMENTS	22-06-02

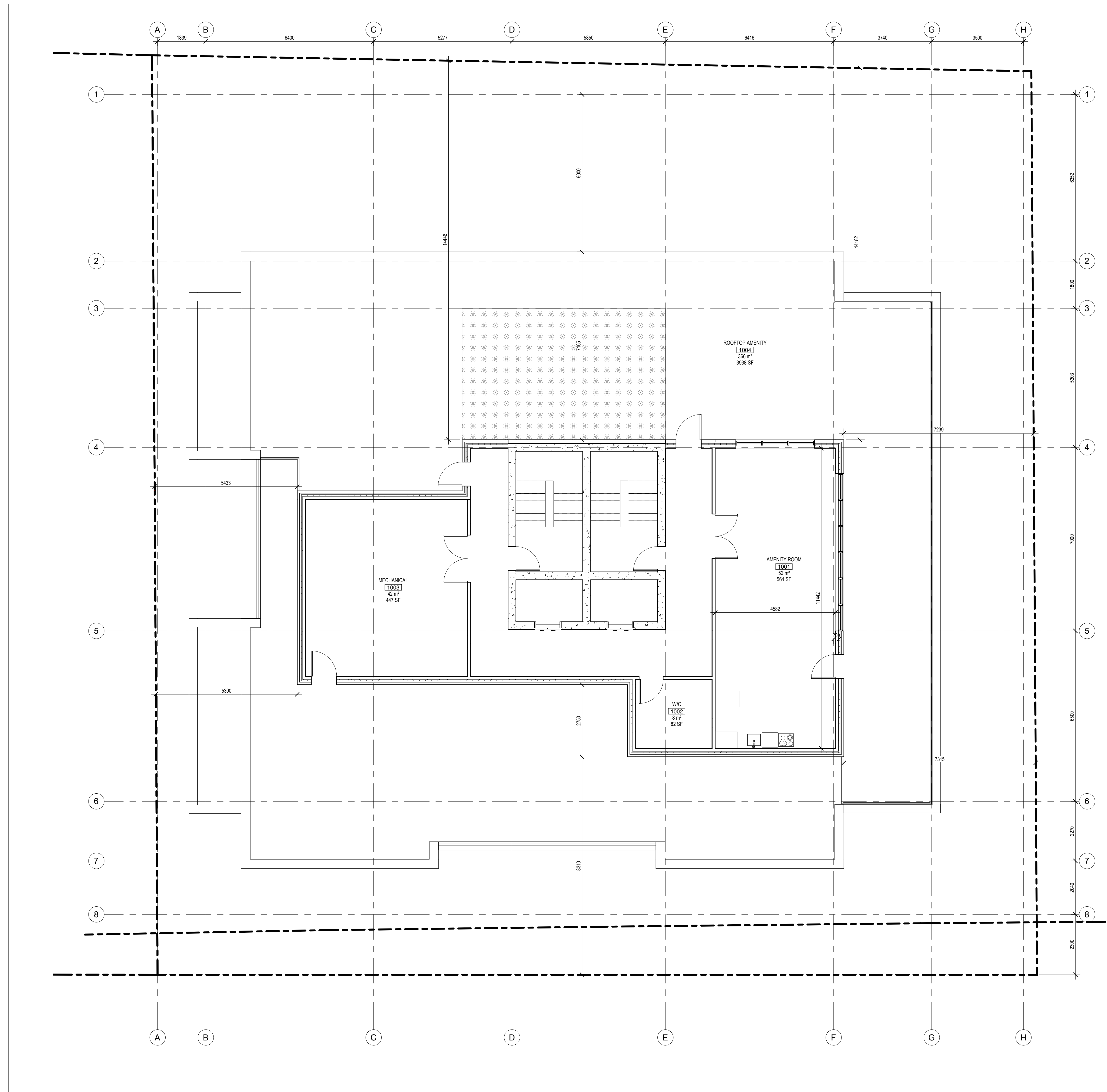

OWNER
Dentech Holdings Inc.
797 Richmond Road, Ottawa, ON K2A 0G7
dentech_899@hotmail.com

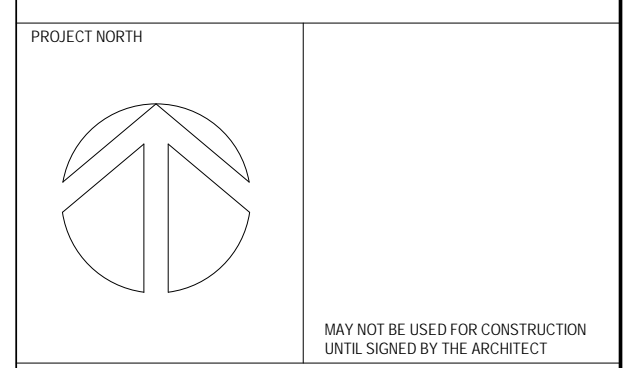

chmielarchitects
200 - 109 Bank Street
Ottawa, ON K1P 5N5
t (613) 234-3585
f (613) 234-6224

797 RICHMOND APARTMENTS
797 RICHMOND ROAD

PROJECT NO. **20-1881** DRAWN **AP**
SCALE **1 : 75** CHECKED **RAC**

DRAWING TITLE
MECH. PH + AMENITY FLOOR PLAN

DRAWING NO.

1 MECH. PH + AMENITY FLOOR PLAN
A-110 SCALE: 1 : 75

A-110

D07-12-21-0088

#18550

NOTE: THIS DRAWING IS THE PROPERTY OF THE ARCHITECT AND MAY NOT BE REPRODUCED OR USED WITHOUT THE EXPRESSED CONSENT OF THE ARCHITECT. THE CONTRACTOR SHALL CHECK AND VERIFY ALL DIMENSIONS AND REPORT ANY OMISSIONS OR DISCREPANCIES TO THE ARCHITECT BEFORE PROCEEDING WITH THE WORK.

DO NOT SCALE THE DRAWINGS

RELEASE / REVISION RECORD

No.	Description	Date
1	ISSUED FOR SPC 1ST RESPONSE TO COMMENTS	22-02-04
2	ISSUED FOR SPC 2ND RESPONSE TO COMMENTS	22-06-02

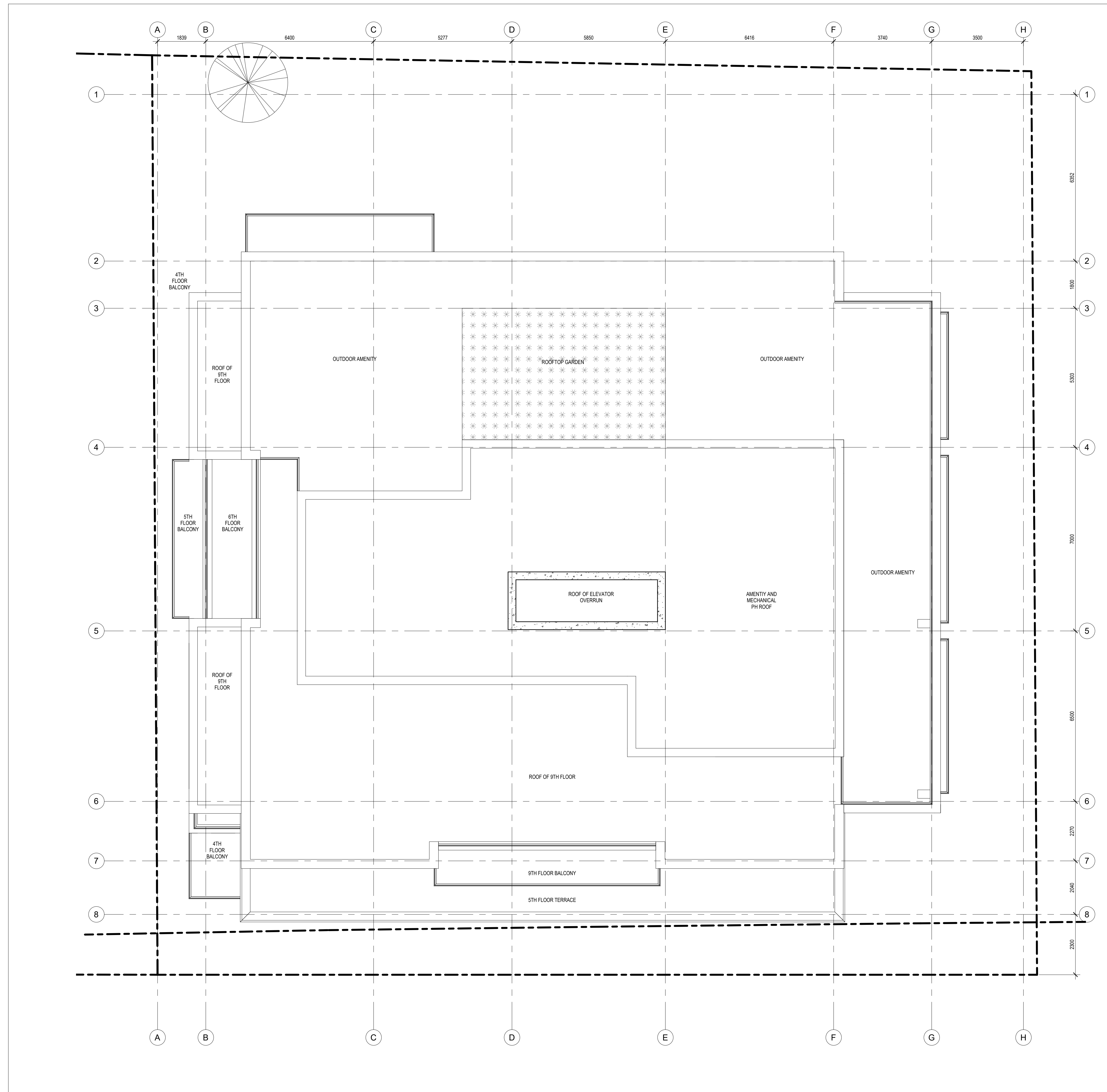

1 ROOF FLOOR PLAN
A-111 SCALE: 1:75

OWNER
Dentech Holdings Inc.
797 Richmond Road, Ottawa, ON K2A 0G7
dentech_899@hotmail.com

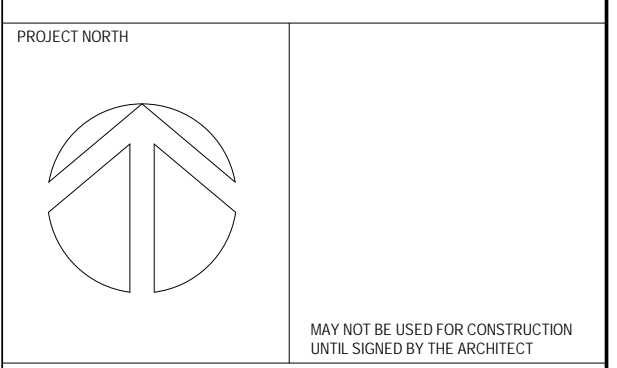

chmielarchitects
200 - 109 Bank Street
Ottawa, ON K1P 5N5
t (613) 234-3585
f (613) 234-6224

797 RICHMOND APARTMENTS
797 RICHMOND ROAD

PROJECT NO. **20-1881** DRAWN **AP**
SCALE **1:75** CHECKED **RAC**

DRAWING TITLE
ROOF FLOOR PLAN

DRAWING NO.
A-111

NOTE: THIS DRAWING IS THE PROPERTY OF THE ARCHITECT AND MAY NOT BE REPRODUCED OR USED WITHOUT THE EXPRESSED CONSENT OF THE ARCHITECT. THE CONTRACTOR SHALL CHECK AND VERIFY ALL DIMENSIONS AND REPORT ANY OMISSIONS OR DISCREPANCIES TO THE ARCHITECT BEFORE PROCEEDING WITH THE WORK.

DO NOT SCALE THE DRAWINGS

RELEASE / REVISION RECORD

No.	Description	Date
1	ISSUED FOR CLIENT REVIEW	22-05-06



4 View from SE Corner
A-202 SCALE



3 View from SW Corner
A-202 SCALE



2 View from NE Corner
A-202 SCALE



1 View from NW Corner
A-202 SCALE

OWNER
Dentech Holdings Inc.
797 Richmond Road, Ottawa, ON K2A 0G7
dentech_899@hotmail.com

PROJECT NORTH

MAY NOT BE USED FOR CONSTRUCTION
UNLESS SIGNED BY THE ARCHITECT

chmielarchitects
200 - 109 Bank Street
Ottawa, ON K1P 5N5
t (613) 234-3585
f (613) 234-6224

797 RICHMOND APARTMENTS
797 RICHMOND ROAD

PROJECT NO. 20-1881 DRAWN CG
SCALE CHECKED RAC

DRAWING TITLE
PERSPECTIVES

DRAWING NO.
A-202

D07-12-21-0088