

END UNIT - PARTIAL FOUNDATION PLAN w/ HYDRO ENCLOSURE

MID UNIT FOUNDATION PLAN

STREET END UNIT FOUNDATION PLAN w/ GAS ENCLOSURE

UNIT 'A' - (LOWER UNIT) END UNIT - 1,116 sq. ft. PART. BASEMENT PLAN w/ HYDRO ENCLOSURE

UNIT 'A' - MID (LOWER) UNIT - OPTION 2, LOWER FLOOR PLAN - 1,097 sq. ft.

UNIT 'A' - STREET END (LOWER) UNIT REV. - OPT. 2 LOWER FLOOR PLAN - 1,150 sq. ft.

UNIT 'A' - END (LOWER) UNIT - OPTION 2, LOWER FLOOR PLAN - 1,116 sq. ft.

M. David Blakely Architect Inc.
 2200 Prince of Wales Dr. - Suite 101
 Ottawa, Ontario K2E 6Z9
 Phone (613) 226-8811 Fax (613) 226-7942

GENERAL NOTES:

1. THE CONTRACTOR IS RESPONSIBLE FOR CHECKING AND VERIFYING ALL DIMENSIONS. ANY DISCREPANCY MUST BE REPORTED TO M. DAVID BLAKELY ARCHITECT INC.
2. ALL WORK AND MATERIALS TO BE IN COMPLIANCE WITH ALL CODES, REGULATIONS, AND BY-LAWS.
3. ADDITIONAL DRAWINGS MAY BE ISSUED FOR CLARIFICATION TO ASSIST THE PROPER EXECUTION OF WORK. SUCH DRAWINGS WILL HAVE THE SAME MARKING AND INTENT AS IF THEY WERE INCLUDED WITH THE PLANS IN CONTRACT DOCUMENTS.
4. DO NOT SCALE DRAWINGS.
5. THIS DRAWING SHALL NOT BE USED OR COPIED WITHOUT THE AUTHORIZATION OF THE ARCHITECT.
6. THIS DRAWING SHALL NOT BE USED FOR PERMIT OR CONSTRUCTION UNLESS THE DRAWING BEARS THE ARCHITECT'S SEAL AND SIGNATURE.
7. THIS REPRODUCTION SHALL NOT BE ALTERED.

POST SCHEDULE

P1 - 3" DIA. ADJUSTABLE STEEL POST	8500 POUND CAP. (MIN.)
P2 - 2"x4x4 OR 8" (AS APPLICABLE)	
P3 - 3"x4x6 OR 8" (AS APPLICABLE)	
P4 - 4"x4x4 OR 8" (AS APPLICABLE)	
P5 - 5"x4x4 OR 8" (AS APPLICABLE)	
P6 - HSS 3"x3x1/8" C/W 5"x3/8"x8" B. PL. & CAP PL.	

BRICK LINTEL SCHEDULE

OPENING UP TO	ANGLE SIZE
5'-0"	L 3 1/2"x3 1/2"x5/16"
7'-0"	L 4x3 1/2"x5/16"
8'-0"	L 5x3 1/2"x5/16"
9'-0"	L 5x3 1/2"x3/8"
10'-0"	L 6x4x3/8"

NOTE: ALL WOOD POST LOCATIONS TO BE BLOCKED SOLID, THRU FLOOR STRUCTURE ON TO A SIMILAR POST BELOW OR ON TO A STEEL / WOOD BEAM OR ON TO THE CONC. FOUNDATION WALL JOIST & TRUSS LAYOUT AS PER MANUFACTURERS ENGINEERED DESIGN.

ARCHITECT SEAL:

NO.	DATE	DESCRIPTION	INT.	NO.	DATE	DESCRIPTION	INT.
11.	15/03/18	FOR MOUNTSHANNON DR. / FOR PERMIT	SM	23.			
10.	24/06/16	AS PER STRUCTURAL / CITY COMMENTS	SM	22.			
9.	25/05/16	FOR PERMIT	SM	21.			
8.	08/03/16	BLOCK 2 - FOR STRUCTURAL REVIEW	SM	20.			
7.	27/11/15	REVISED FOR BLOCK 3	SM	19.			
6.	23/09/15	ISSUED FOR CONSTRUCTION	SM	18.			
5.	18/12/14	BLOCKS 2 & 3 - FOR PERMIT	SM	17.			
4.	15/10/14	GENERAL REV. AS PER BLOCK 1	SM	16.			
3.	27/01/14	REVISED FRONT PORCH - ADDED BRICK	SM	15.			
2.	06/06/13	AS PER STRUCTURAL / FOR PERMIT	SM	14.			
1.	20/05/13	FOR STRUCTURAL REVIEW	SM	13.			
		FOR REVIEW	SM	12.	15/08/18	REVISED FOUNDATION ELEVATIONS	SM

A - DETAIL NUMBER
 B - SHEET NUMBER
 C - SHEET NUMBER (DETAIL LOCATION)

PROJECT: **TERRACE FLATS**
 146 MOUNTSHANNON DRIVE
 OTTAWA, ONT.

CLIENT: **RICHCRAFT**
 Group Of Companies

DRAWING TITLE: **FOUNDATION PLANS & UNIT TYPE 'A' (LOWER UNIT) BASEMENT PLANS**

DATE: MAY, 2013. SCALE: 3/16" = 1'-0"

DRAWN BY: SBM CHECKED: MDB

SHEET No.: **A-2**

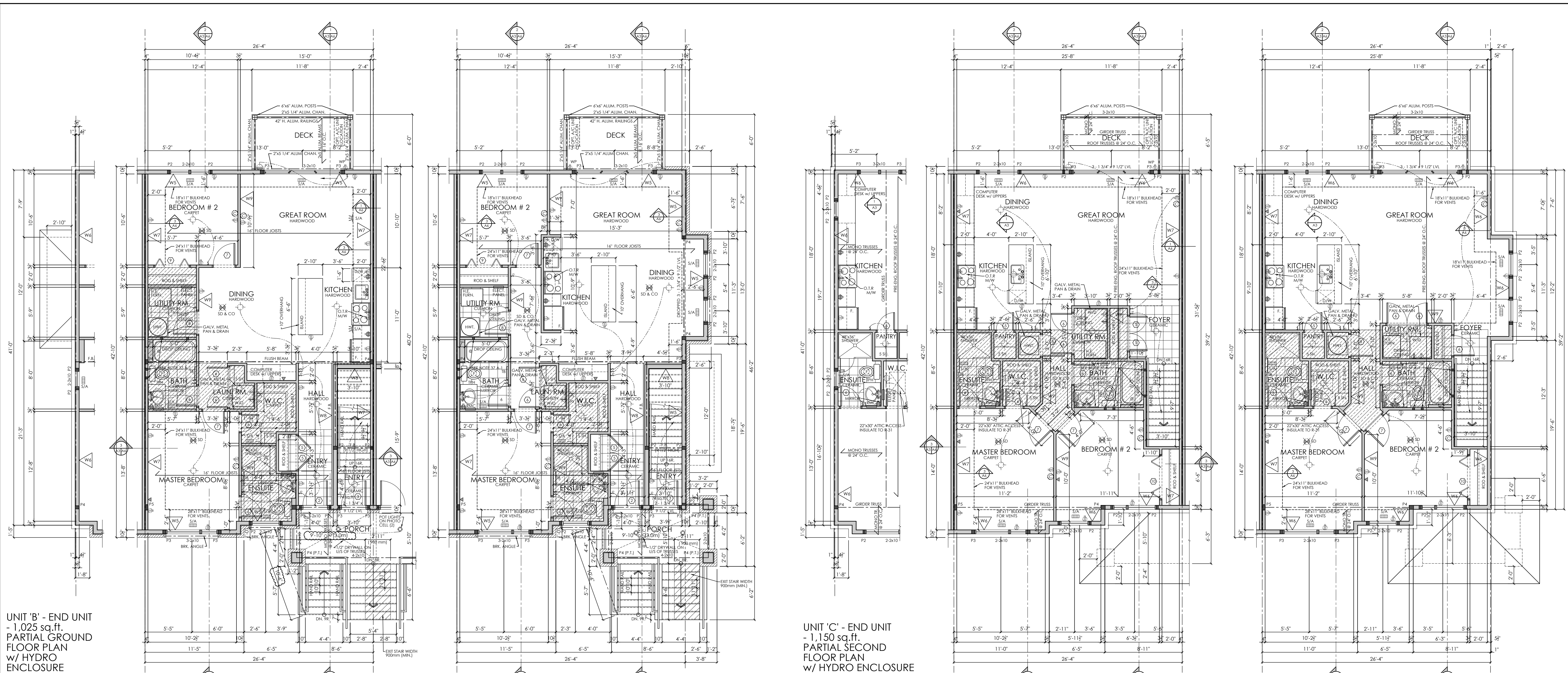

UNIT 'B' - END UNIT
- 1,025 sq.ft.
PARTIAL GROUND
FLOOR PLAN
w/ HYDRO
ENCLOSURE

UNIT 'B' - MID (GROUND) UNIT
GROUND FLOOR PLAN - 1,024 sq.ft.

UNIT 'B' - STREET END (GROUND) UNIT
GROUND FLOOR PLAN - 1,065 sq.ft.

UNIT 'C' - END UNIT
- 1,150 sq.ft.
PARTIAL SECOND
FLOOR PLAN
w/ HYDRO ENCLOSURE

UNIT 'C' - MID (SECOND) UNIT,
SECOND FLOOR PLAN - 1,148 sq.ft.

UNIT 'C' - STREET END (SECOND) UNIT
SECOND FLOOR PLAN - 1,182 sq.ft.

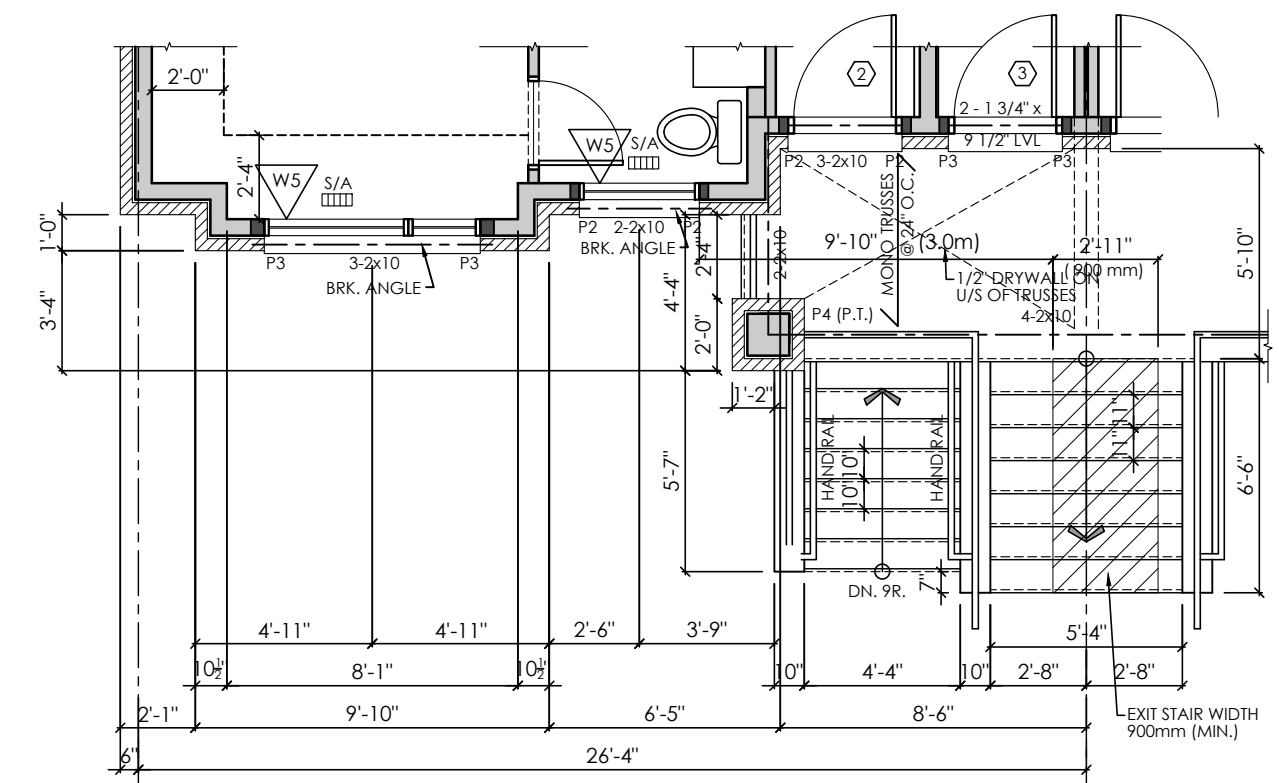

UNIT 'B' - END (GROUND) UNIT
GROUND FLOOR PLAN - 1,043 sq.ft.

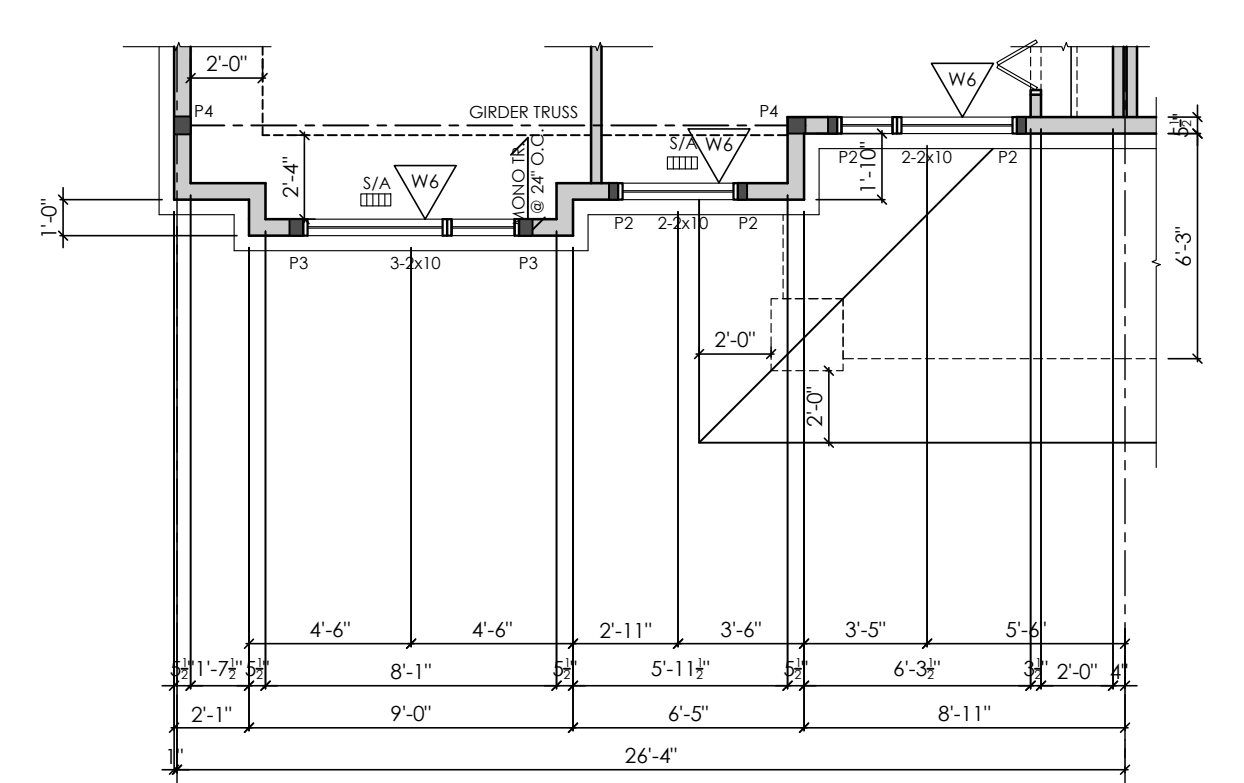

UNIT 'C' - END (SECOND) UNIT,
SECOND FLOOR PLAN - 1,150 sq.ft.

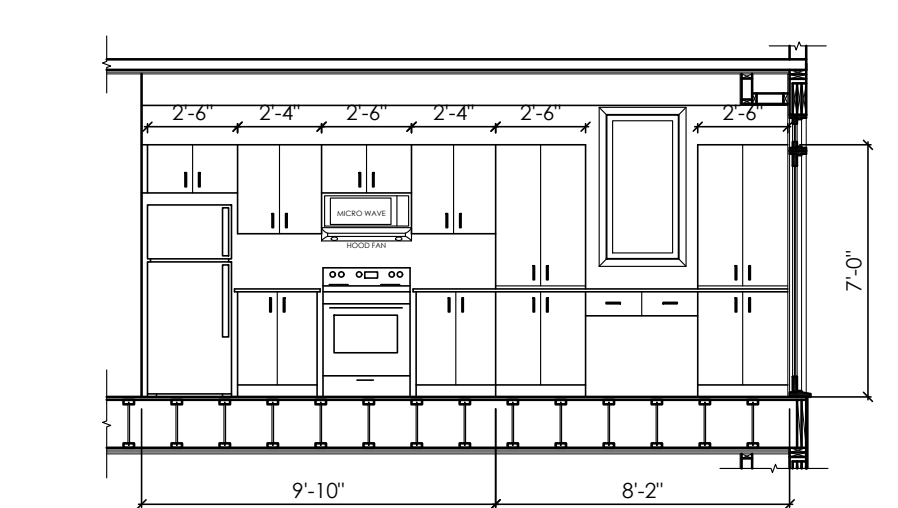

UNIT 'C' - KITCHEN / COMPUTER DESK ELEVATION
SCALE 3/16" = 1'-0"

NOTE:
ALL WOOD POST LOCATIONS TO BE BLOCKED SOLID, THRU FLOOR STRUCTURE ON TO A
SIMILAR POST BELOW OR ON TO A STEEL / WOOD BEAM OR ON TO THE CONC. FOUNDATION WALL
JOIST & TRUSS LAYOUT AS PER MANUFACTURERS ENGINEERED DESIGN.

M. David Blakely
Architect Inc.
2200 Prince of Wales Dr. - Suite 101
Ottawa, Ontario K2E 6Z9
Phone (613) 226-8811 Fax (613) 226-7942

GENERAL NOTES:
1. THE CONTRACTOR IS RESPONSIBLE FOR CHECKING AND VERIFYING ALL DIMENSIONS. ANY DISCREPANCY MUST BE REPORTED TO M. DAVID BLAKELY ARCHITECT INC.
2. ALL WORK AND MATERIALS TO BE IN COMPLIANCE WITH ALL CODES, REGULATIONS, AND BY-LAWS.
3. ADDITIONAL DRAWINGS MAY BE ISSUED FOR CLARIFICATION TO ASSIST THE PROPER EXECUTION OF WORK. SUCH DRAWINGS WILL HAVE THE SAME MEANING AND INTENT AS IF THEY WERE INCLUDED WITH THE PLANS IN CONTRACT DOCUMENTS.
4. DO NOT SCALE DRAWINGS.
5. THIS DRAWING SHALL NOT BE USED OR COPIED WITHOUT THE AUTHORIZATION OF THE ARCHITECT.

6. THIS DRAWING SHALL NOT BE USED FOR PERMIT OR CONSTRUCTION UNLESS THE DRAWING BEARS THE ARCHITECT'S SEAL AND SIGNATURE.
7. THIS REPRODUCTION SHALL NOT BE ALTERED.

POST SCHEDULE

P1 - 3" DIA. ADJUSTABLE STEEL POST	8500 POUND CAP. (MIN.)
P2 - 2"x4x8 OR 8" (AS APPLICABLE)	
P3 - 3"x4x8 OR 8" (AS APPLICABLE)	
P4 - 4"x4x8 OR 8" (AS APPLICABLE)	
P5 - 5"x4x8 OR 8" (AS APPLICABLE)	
P6 - HSS 3"x3x1/8" C/W 5"x3/8"x8" B. PL. & CAP PL.	

BRICK LINTEL SCHEDULE

OPENING	ANGLE SIZE
5'-0"	L 3 1/2"x3 1/2"x5/16"
7'-0"	L 4"x3 1/2"x5/16"
8'-0"	L 5"x3 1/2"x5/16"
9'-0"	L 5"x3 1/2"x3/8"
10'-0"	L 6"x4"x3/8"

ARCHITECT SEAL:

11. 15/03/18 FOR MOUNTSHANNON DR. / FOR PERMIT SM 23.
10. 24/06/16 AS PER STRUCTURAL / CITY COMMENTS SM 22.
9. 25/05/16 BLOCK 7 - FOR STRUCTURAL REVIEW SM 20.
8. 08/03/16 REVISED FOR BLOCK 3 SM 19.
7. 27/11/15 ISSUED FOR CONSTRUCTION SM 18.
6. 23/09/15 BLOCKS 2 & 3 - FOR PERMIT SM 17.
5. 18/12/14 GENERAL REV. AS PER BLOCK 1 SM 16.
4. 15/10/14 REVISED FRONT PORCH - ADDED BRICK SM 15.
3. 27/01/14 AS PER STRUCTURAL / FOR PERMIT SM 14.
2. 06/06/13 FOR STRUCTURAL REVIEW SM 13.
1. 20/05/13 FOR REVIEW SM 12. 15/08/18 REVISED FOUNDATION ELEVATIONS SM

NO.	DATE	DESCRIPTION	REVISED	NO.	DATE	DESCRIPTION	REVISED
11.	15/03/18	FOR MOUNTSHANNON DR. / FOR PERMIT	SM	23.			
10.	24/06/16	AS PER STRUCTURAL / CITY COMMENTS	SM	22.			
9.	25/05/16	BLOCK 7 - FOR STRUCTURAL REVIEW	SM	20.			
8.	08/03/16	REVISED FOR BLOCK 3	SM	19.			
7.	27/11/15	ISSUED FOR CONSTRUCTION	SM	18.			
6.	23/09/15	BLOCKS 2 & 3 - FOR PERMIT	SM	17.			
5.	18/12/14	GENERAL REV. AS PER BLOCK 1	SM	16.			
4.	15/10/14	REVISED FRONT PORCH - ADDED BRICK	SM	15.			
3.	27/01/14	AS PER STRUCTURAL / FOR PERMIT	SM	14.			
2.	06/06/13	FOR STRUCTURAL REVIEW	SM	13.			
1.	20/05/13	FOR REVIEW	SM	12.	15/08/18	REVISED FOUNDATION ELEVATIONS	SM

PROJECT:
TERRACE FLATS
146 MOUNTSHANNON DRIVE
OTTAWA, ONT.

CLIENT:
RICHCRAFT
Group Of Companies

DRAWING TITLE:
UNIT TYPE 'B' & 'C'
FLOOR PLANS,
KITCHEN ELEVATION

DATE: MAY, 2013. **SCALE:** 3/16" = 1'-0"

DRAWN BY: SBM **CHECKED:** MDB

SHEET NO.: A-3

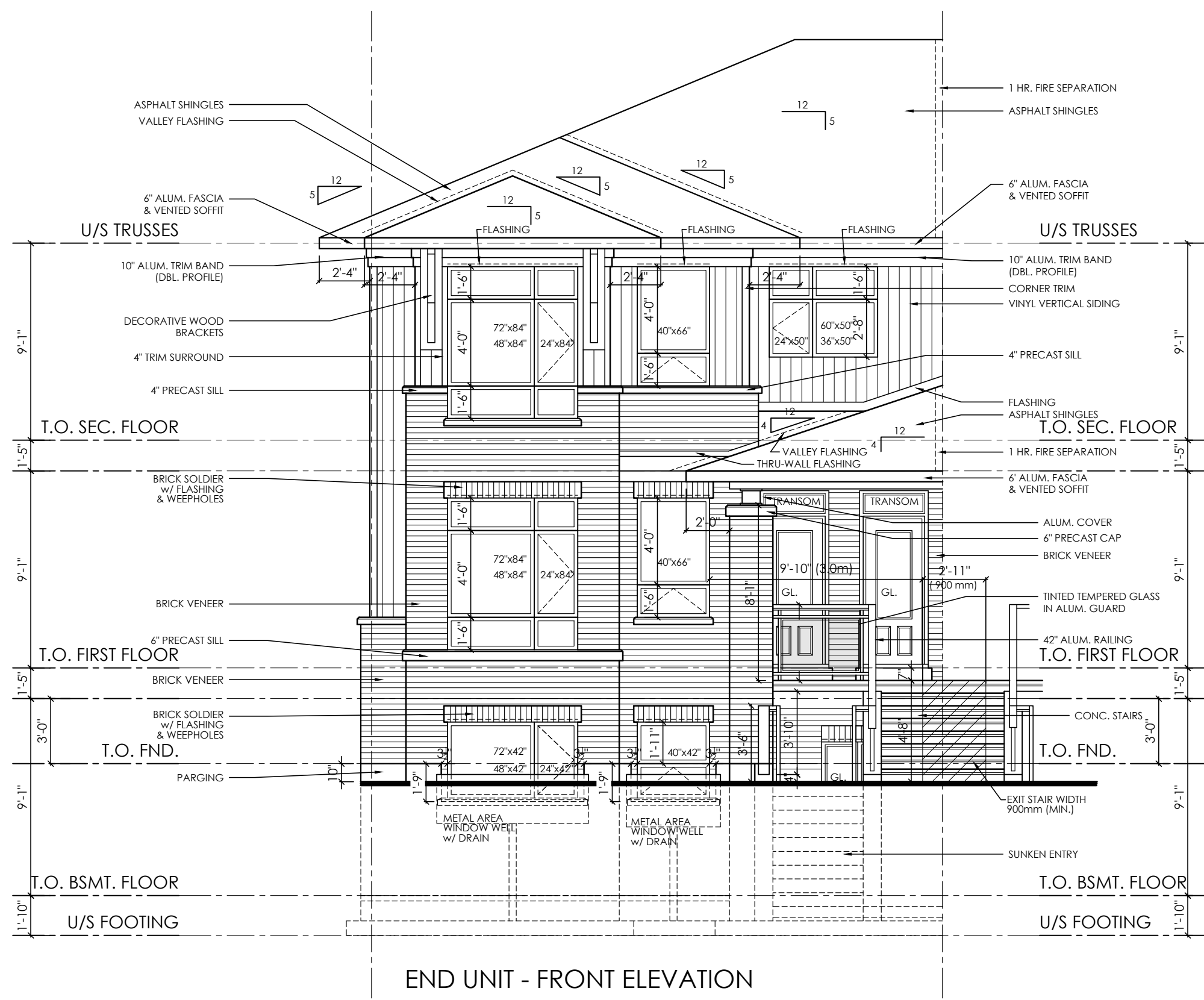

END UNIT - FRONT ELEVATION

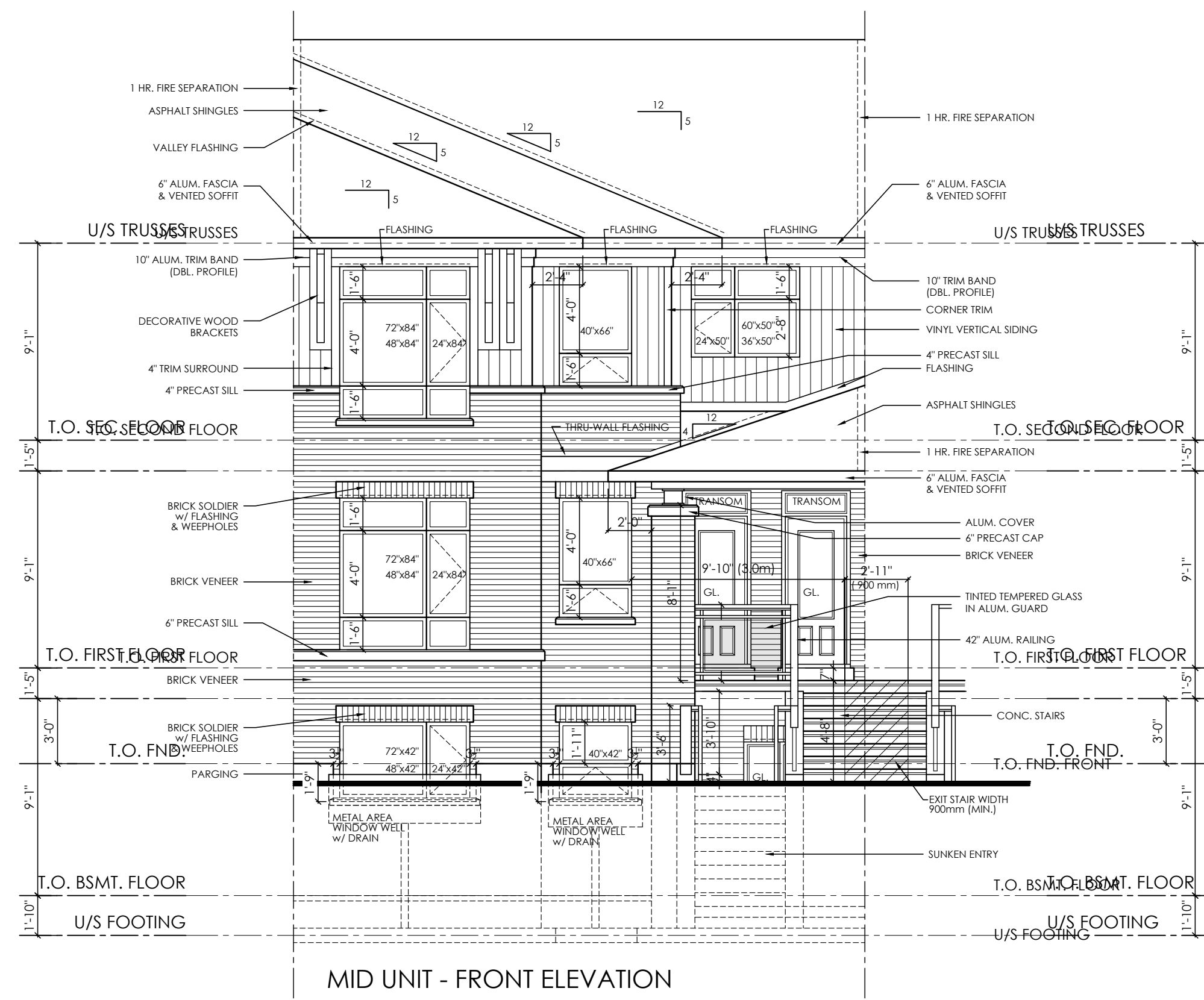

MID UNIT - FRONT ELEVATION

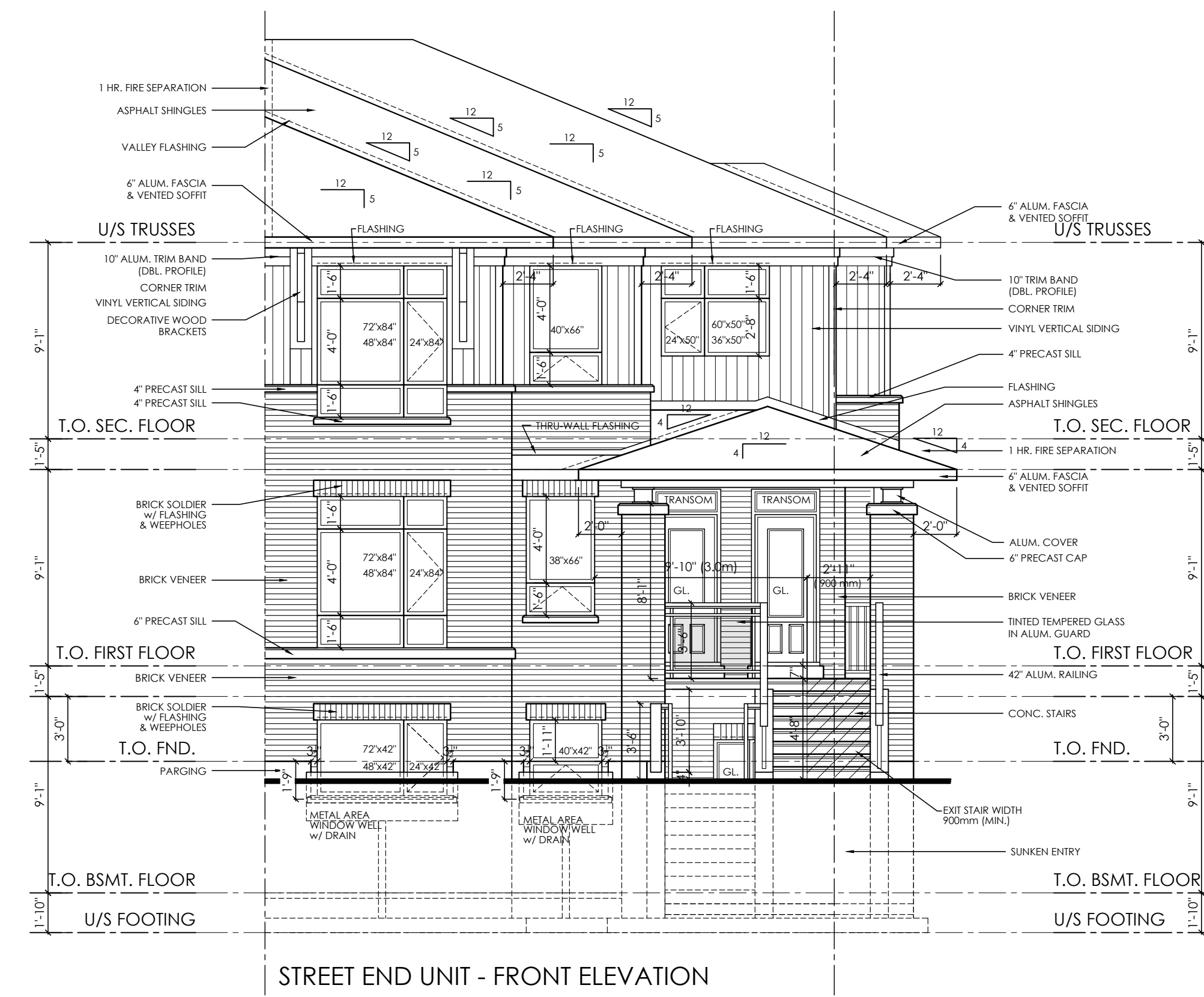

STREET END UNIT - FRONT ELEVATION

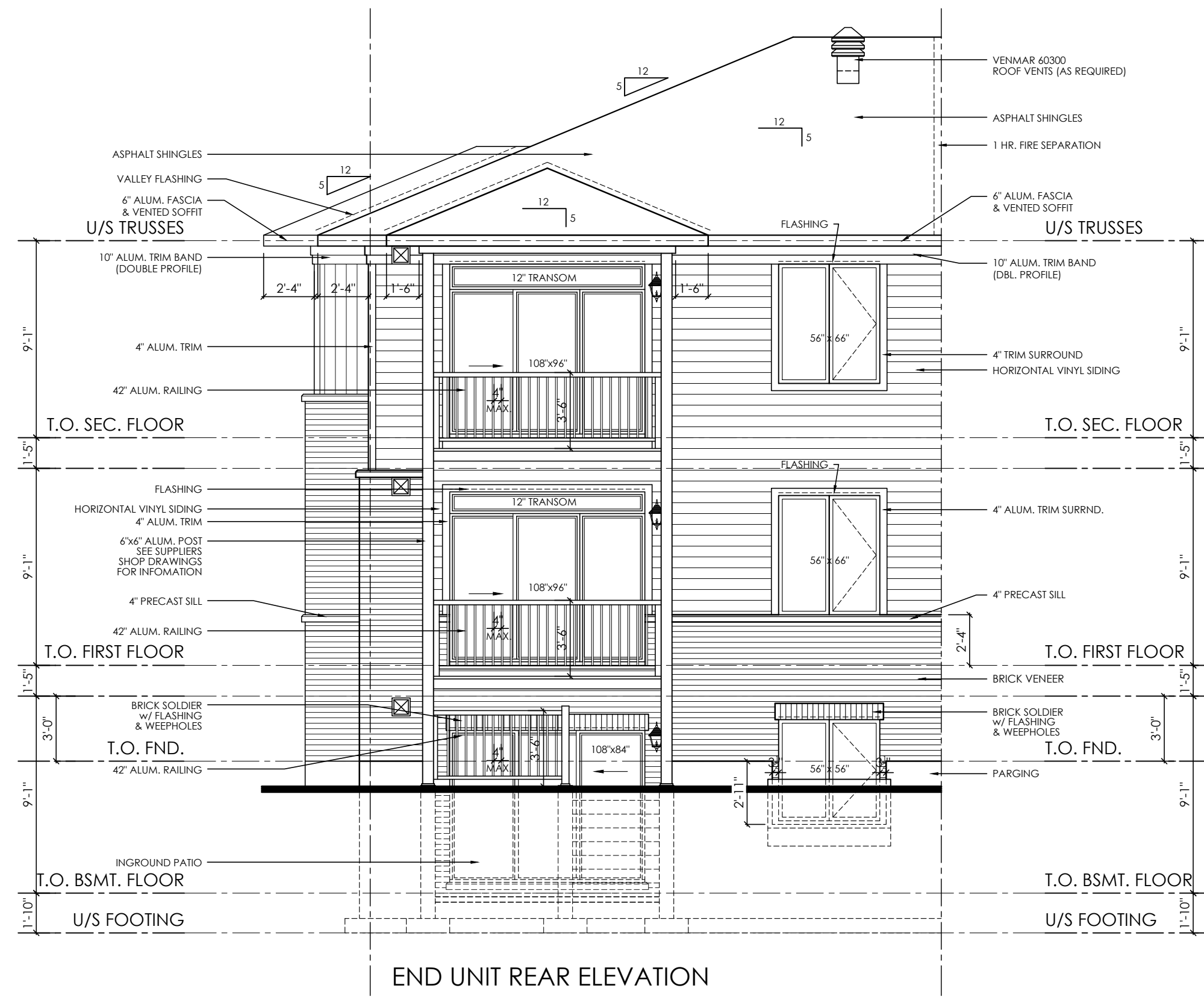

END UNIT REAR ELEVATION

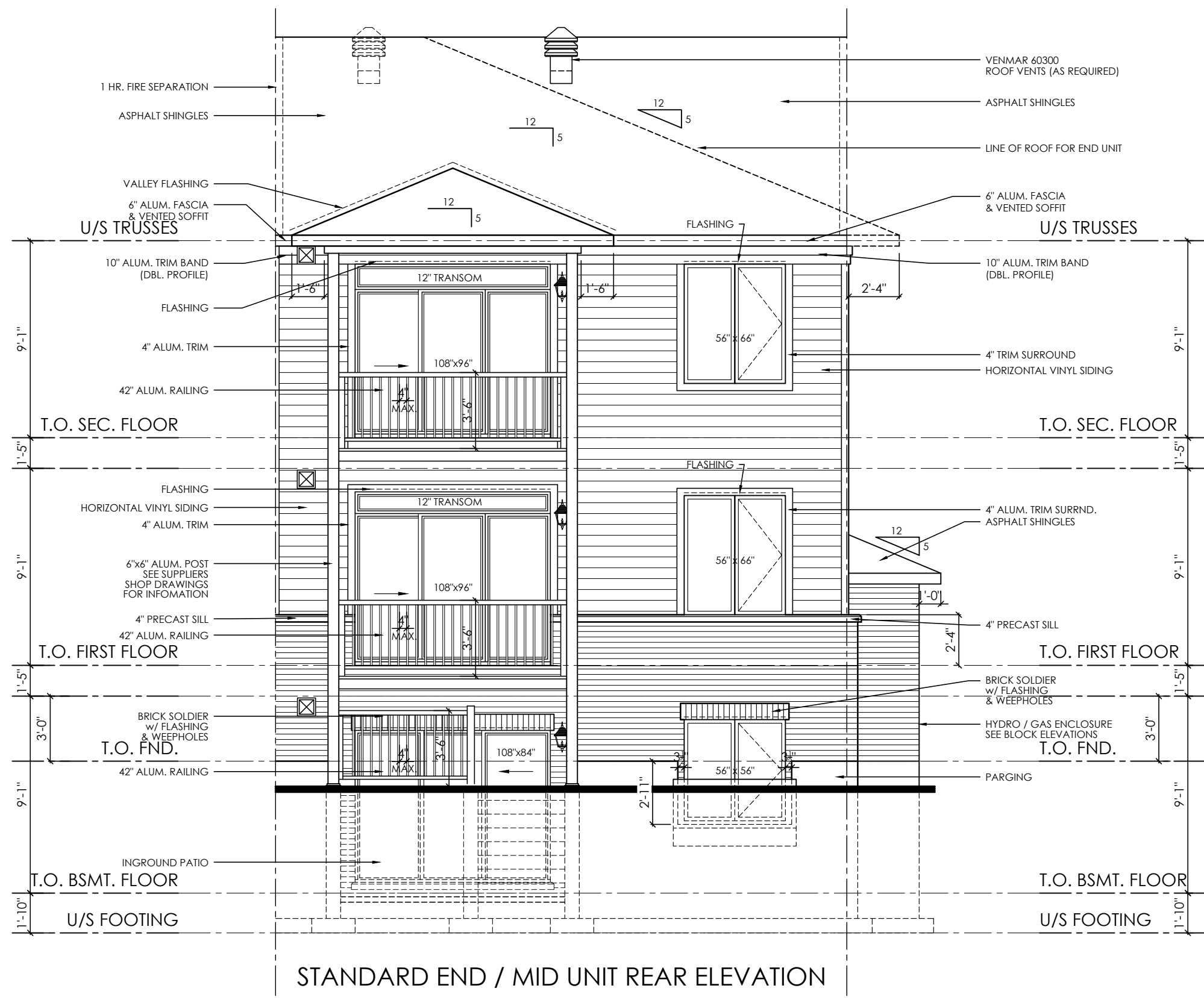

STANDARD END / MID UNIT REAR ELEVATION

GENERAL NOTES:
 1. THE CONTRACTOR IS RESPONSIBLE FOR CHECKING AND VERIFYING ALL DIMENSIONS. ANY DISCREPANCY MUST BE REPORTED TO M. DAVID BLAKELY ARCHITECT INC.
 2. ALL WORK AND MATERIALS TO BE IN COMPLIANCE WITH ALL CODES, REGULATIONS, AND BY-LAWS.
 3. ADDITIONAL DRAWINGS MAY BE ISSUED FOR CLARIFICATION TO ASSIST THE PROPER EXECUTION OF WORK. SUCH DRAWINGS WILL HAVE THE SAME MEANING AND INTENT AS IF THEY WERE INCLUDED WITH THE PLANS IN CONTRACT DOCUMENTS.
 4. DO NOT SCALE DRAWINGS.
 5. THIS DRAWING SHALL NOT BE USED OR COPIED WITHOUT THE AUTHORIZATION OF THE ARCHITECT.

POST SCHEDULE

P1 - 3" DIA. ADJUSTABLE STEEL TELEPOST 8500 POUND CAP. (MIN.)	
P2 - 2"x4" OR 8" (AS APPLICABLE)	
P3 - 3"x4" OR 8" (AS APPLICABLE)	
P4 - 4"x4" OR 8" (AS APPLICABLE)	
P5 - 5"x4" OR 8" (AS APPLICABLE)	
P6 - HSS 3"x3"x1/8" C/W 5"x3/8"x8" B. PL. & CAP PL.	

BRICK LINTEL SCHEDULE

OPENING UP TO	ANGLE SIZE
5'-0"	L 3 1/2"x3 1/2"x5/16"
7'-0"	L 4"x3 1/2"x5/16"
8'-0"	L 5"x3 1/2"x5/16"
9'-0"	L 5"x3 1/2"x3/8"
10'-0"	L 6"x4"x3/8"

ARCHITECT SEAL:

NO.	DATE	DESCRIPTION	REVISED	NO.	DATE	DESCRIPTION	REVISED
11.	15/03/18	FOR MOUNTSHANNON DR. / FOR PERMIT	SM	23.			
10.	24/06/16	AS PER STRUCTURAL / CITY COMMENTS	SM	22.			
9.	25/05/16	BLOCK 2 - FOR STRUCTURAL REVIEW	SM	21.			
8.	08/03/16	REVISED FOR BLOCK 3	SM	19.			
7.	27/11/15	ISSUED FOR CONSTRUCTION	SM	18.			
6.	23/09/15	BLOCKS 2 & 3 - FOR PERMIT	SM	17.			
5.	18/12/14	GENERAL REV. AS PER BLOCK 1	SM	16.			
4.	15/10/14	REVISED FRONT PORCH - ADDED BRICK	SM	15.			
3.	27/01/14	AS PER STRUCTURAL / FOR PERMIT	SM	14.			
2.	06/06/13	FOR STRUCTURAL REVIEW	SM	13.			
1.	20/05/13	FOR REVIEW	SM	12.	15/08/18	REVISED FOUNDATION ELEVATIONS	SM

A - DETAIL NUMBER
 B - SHEET NUMBER (DETAIL LOCATION)
 C - SHEET NUMBER

PROJECT: **TERRACE FLATS**
 146 MOUNTSHANNON DRIVE
 OTTAWA, ONT.

CLIENT: **RICHCRAFT**
 Group Of Companies

DRAWING TITLE: **ELEVATIONS**

DATE: **MAY, 2013.** SCALE: **3/16" = 1'-0"** SHEET NO.: **A-4**

DRAWN BY: **SBM** CHECKED: **MDB**

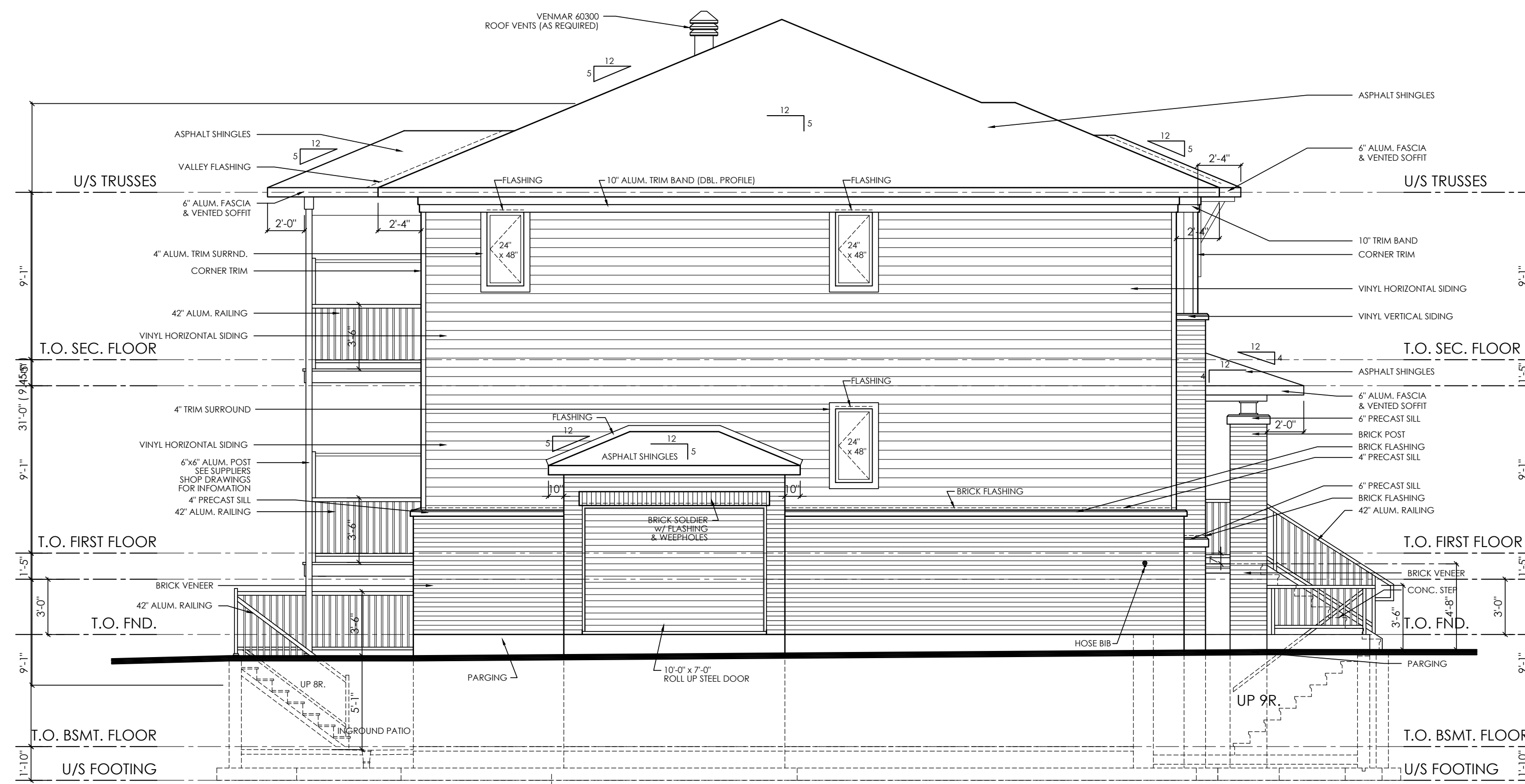

END UNIT, SIDE ELEVATION w/ HYDRO/GAS METER ENCLOSURE

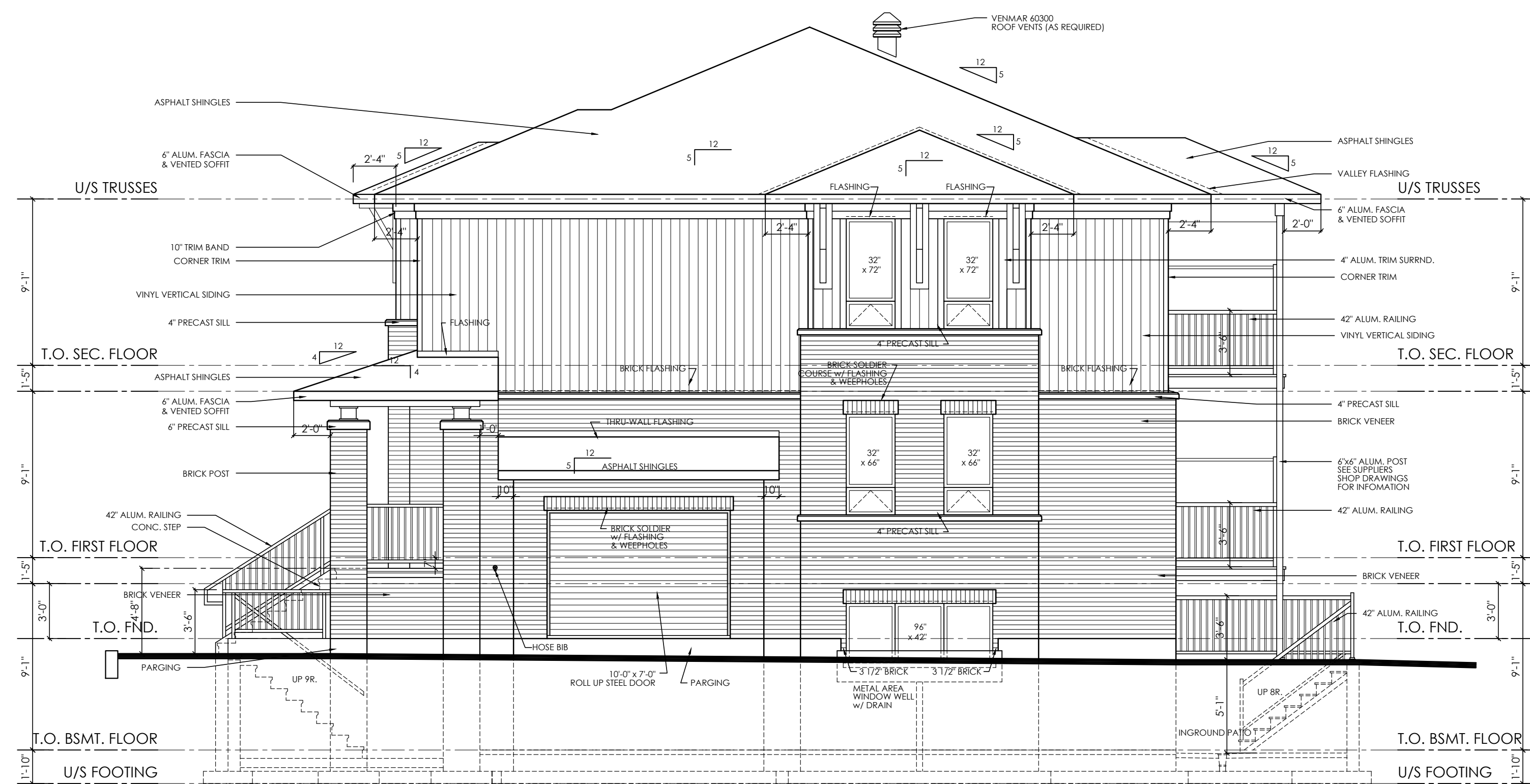

STREET END UNIT, SIDE ELEVATION w/ GAS METER ENCLOSURE

M. David Blakely
Architect Inc.
2200 Prince of Wales Dr. - Suite 101
Ottawa, Ontario K2E 6Z9
Phone (613) 226-8811 Fax (613) 226-7942

GENERAL NOTES:
1. THE CONTRACTOR IS RESPONSIBLE FOR CHECKING AND VERIFYING ALL DIMENSIONS. ANY DISCREPANCY MUST BE REPORTED TO M. DAVID BLAKELY ARCHITECT INC.
2. ALL WORK AND MATERIALS TO BE IN COMPLIANCE WITH ALL CODES, REGULATIONS, AND BY-LAWS.
3. ADDITIONAL DRAWINGS MAY BE ISSUED FOR CLARIFICATION TO ASSIST THE PROPER EXECUTION OF WORK. SUCH DRAWINGS WILL HAVE THE SAME MEANING AND INTENT AS IF THEY WERE INCLUDED WITH THE PLANS IN CONTRACT DOCUMENTS.
4. DO NOT SCALE DRAWINGS.
5. THIS DRAWING SHALL NOT BE USED OR COPIED WITHOUT THE AUTHORIZATION OF THE ARCHITECT.

6. THIS DRAWING SHALL NOT BE USED FOR PERMIT OR CONSTRUCTION UNLESS THE DRAWING BEARS THE ARCHITECT'S SEAL AND SIGNATURE.
7. THIS REPRODUCTION SHALL NOT BE ALTERED.

POST SCHEDULE

P1 - 3" DIA. ADJUSTABLE STEEL TELEPOST 8500 POUND CAP. (MIN.)
P2 - 2"x4" OR 8" (AS APPLICABLE)
P3 - 3"x4" OR 8" (AS APPLICABLE)
P4 - 4"x4" OR 8" (AS APPLICABLE)
P5 - 5"x4" OR 8" (AS APPLICABLE)
P6 - HSS 3"x3"x.188" C/W 5"x3/8"x8" B. PL. & CAP PL.

BRICK LINTEL SCHEDULE

OPENING	ANGLE SIZE
UP TO 5'-0"	L 3 1/2"x3 1/2"x5/16"
5'-0" TO 7'-0"	L 4"x3 1/2"x5/16"
7'-0" TO 8'-0"	L 5"x3 1/2"x5/16"
8'-0" TO 9'-0"	L 5"x3 1/2"x3/8"
10'-0"	L 6"x4"x3/8"

ARCHITECT SEAL:

NO.	DATE	DESCRIPTION	REVISED	NO.	DATE	DESCRIPTION	REVISED
11.	15/03/18	FOR MOUNTSHANNON DR. / FOR PERMIT	SMX	23.			
10.	24/06/16	AS PER STRUCTURAL / CITY COMMENTS	SM	22.			
9.	25/05/16	FOR PERMIT	SM	21.			
8.	08/03/16	FOR STRUCTURAL REVIEW	SM	20.			
7.	27/11/15	REVISED FOR BLOCK 3	SM	19.			
6.	23/09/15	ISSUED FOR CONSTRUCTION	SM	18.			
5.	18/12/14	BLOCKS 2 & 3 - FOR PERMIT	SM	17.			
4.	15/10/14	GENERAL REV. AS PER BLOCK 1	SM	16.			
3.	27/01/14	REVISED FRONT PORCH - ADDED BRICK	SM	15.			
2.	06/06/13	FOR STRUCTURAL REVIEW	SM	14.			
1.	20/05/13	FOR REVIEW	SM	13.	15/08/18	REVISED FOUNDATION ELEVATIONS	SM

A - DETAIL NUMBER
B - SHEET NUMBER (DETAIL REQUIRED)
C - SHEET NUMBER (DETAIL LOCATION)

PROJECT: **TERRACE FLATS**
146 MOUNTSHANNON DRIVE
OTTAWA, ONT.

CLIENT: **RICHCRAFT**
Group Of Companies

DRAWING TITLE: **ELEVATIONS**

DATE: **MAY, 2013.** SCALE: **3/16" = 1'-0"** SHEET NO.: **A-5**

DRAWN BY: **SBM** CHECKED: **MDB**

