

CONCRETE - FINISH LIGHT BROOM, WOOD FLOAT MAGNESIUM FLOAT:
 ALL CONCRETE FINISHES TO BE APPROVED BY GJA LANDSCAPE ARCHITECT.
 SAWCUT LAYOUT FOR ALL AREAS TO BE MARKED ON SITE IN RED CHALK, REVIEWED, ADJUSTED AND APPROVED BY GJA LANDSCAPE ARCHITECT PRIOR TO ANY CUTTING.
 EXPANSION JOINT LAYOUT FOR ALL AREAS TO BE LAID OUT ON SITE - REVIEWED, ADJUSTED AND APPROVED BY GJA LANDSCAPE ARCHITECT PRIOR TO ANY CONCRETE POURING.
 PROVIDE COLD JOINT DETAIL at End of Previous Pour/Beginning of New Pour, C/W REBAR DOWELS 500mm O.C.
FINISH: TOOL EDGE FIRST, THEN WIFE OFF TOOL MARKS WHILE APPLYING FINISH.

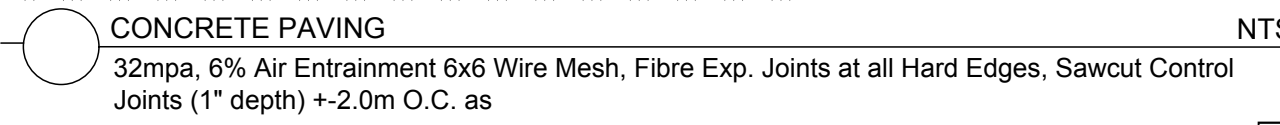

CONCRETE PAVING
 32mpa, 6% Air Entrainment 6x6 Wire Mesh, Fibre Exp. Joints at All Hard Edges, Sawcut Control Joints (1" depth) +2.0m O.C. as

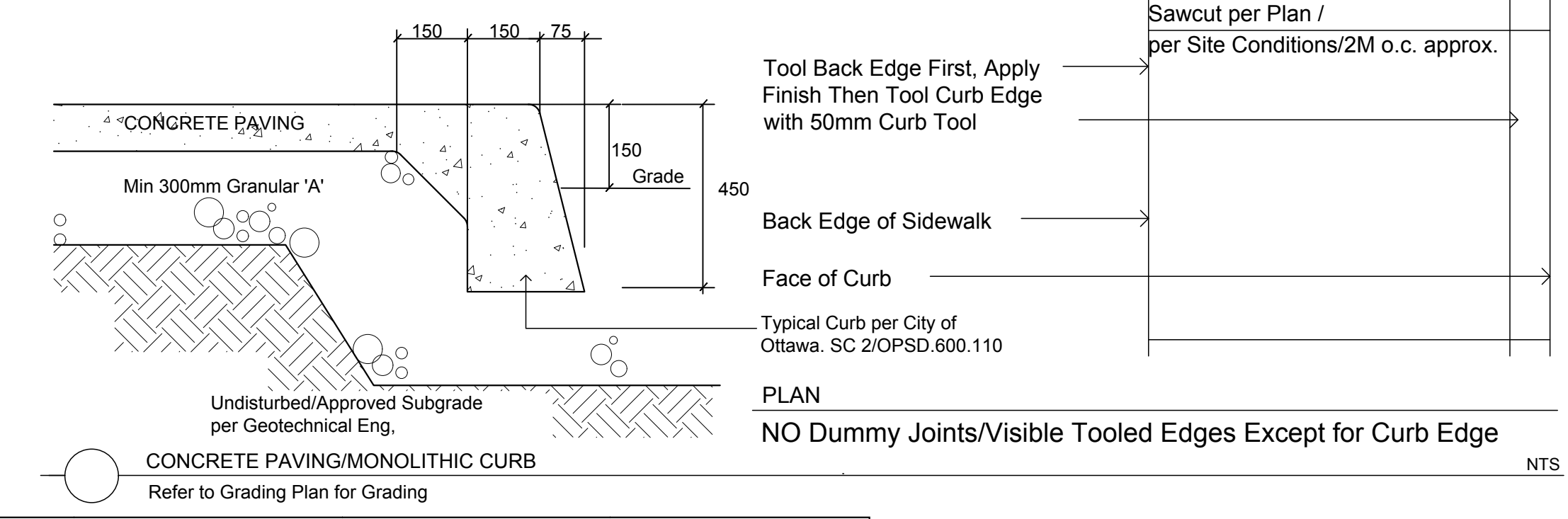
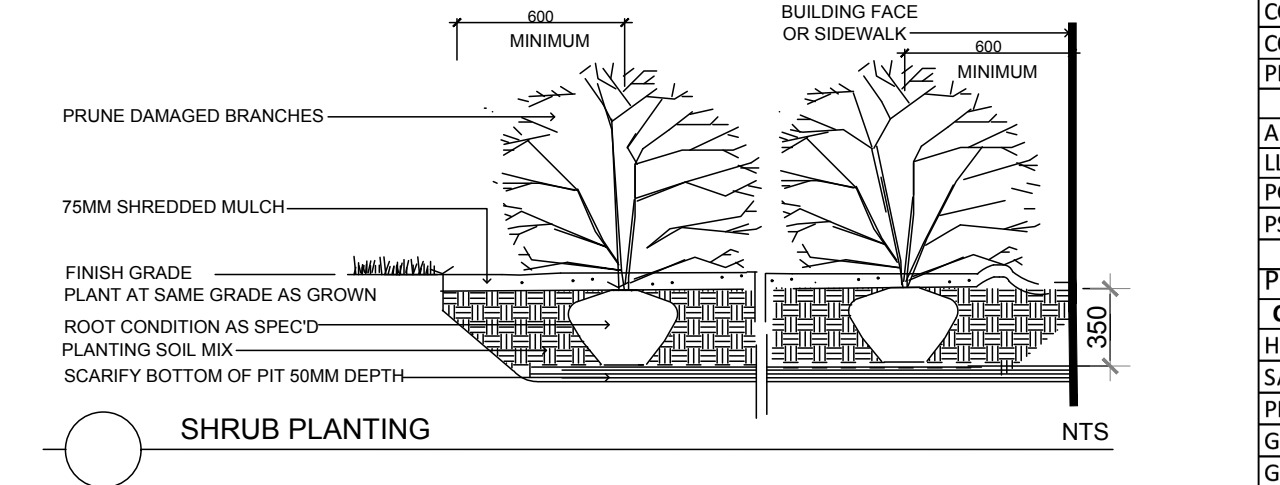

CALIPER B AND B TREES - 1195 NEWMARKET STREET OTTAWA. GJA INC.

Code	Qty.	Botanical Name	Common Name	Size	Condition
AC	2	Amelanchier canadensis	Tree Serviceberry	60mm cal	B + B specimen
AG	3	Aesculus glabra	Ohio Buckeye	60mm cal	B + B specimen
AR	2	Acer rubrum	Red Maple	70mm cal	B + B specimen
AS	1	Acer saccharum	Sugar Maple	70mm cal	B + B specimen
CC	2	Carpinus caroliniana	Hornbeam Bluebeech	60mm cal	B + B specimen
CO	1	Celtis occidentalis	Common Hackberry	70mm cal	B + B specimen
PP	1	Prunus pennsylvanica	Pin Cherry	60mm cal	B + B specimen
AB	3	Abies balsamea	Balsam Fir	1.75m Ht.	B + B specimen
LL	3	Larix laricina	Eastern Larch / Tamarack	2.0m Ht.	B + B specimen
PG	4	Picea glauca	White Spruce	2.25m Ht.	B + B specimen
PS	3	Pinus strobus	White Pine	1.5m Ht.	B + B specimen

POTTED SHRUBS - 1195 NEWMARKET STREET OTTAWA. GJA INC.

Code	Qty.	Botanical Name	Common Name	Size	Condition
HK	125	Hypericum kalmianum	St. John's Wort	30cm HL	Pot
SA	370	Spiraea alba	Meadowsweet	50cm HL	Pot
PM	150	Pinus mugo var. pumilio	Dwarf Mugho Pine	30 cm spr	B + B specimen
GM	125	Geranium macrorrhizum	Bigroot Geranium	9cm Pot	
GP	125	Geranium psilostemon 'Gerwat'	Rozanne Geranium	9cm Pot	
PQ	250	Parthenocissus quinquefolia	Virginia Creeper	9cm Pot	



Drawing Remains the Property of/Copyright Reserved by Gino J. Aiello Landscape Architect. Do Not Use or Reproduce Without Approval of Gino J. Aiello.
NOT TO BE USED FOR CONSTRUCTION UNLESS INDICATED BY REVISION: "FOR LANDSCAPE CONSTRUCTION"
Contractor is Responsible for Verification of Site Locations of all Utilities. Report any Discrepancies Between Site and Drawing Immediately to Gino J. Aiello. Do NOT Proceed Until Clarified.
 TURF AREAS TO BE SOD C/W 150MM DEPTH TOPSOIL ON APPROVED SUBGRADE | SOD TO BE #1 GRADE TURFGRASS NURSERY SOD per NSGA - Fine Fescue/Kentucky Bluegrass Sod | PLANTING MIX TO BE APPROVED BY LANDSCAPE ARCHITECT | PLANT MATERIAL TO MEET CNLA STANDARDS/BE APPROVED BY LANDSCAPE ARCHITECT PRIOR TO PLANTING | ALL MATERIALS & WORK TO BE MAINTAINED UNTIL FINAL ACCEPTANCE. (MOWING TURF, WEEDING BEDS, WATERING TURF & PLANTS) & INCLUDE 1 YEAR WARRANTY FROM DATE OF FINAL ACCEPTANCE | PROVIDE WATERING OF ALL PLANT MATERIAL AS REQUIRED FOR PROPER ESTABLISHMENT, UNTIL END OF WARRANTY PERIOD | REFER TO CIVIL ENGINEER'S DRAWING FOR ELEVATIONS / GRADING |
 The Landscape Plan is to be read in conjunction with the grading, servicing, site and survey plan | Bare root material to be planted in season only | All plant material locations to be staked on site by the landscape contractor and checked by the landscape architect prior to planting | All trees to be preserved on or directly adjacent to the site will be protected | Plant material are to be installed a minimum of 3.0m away from any part of any hydro transformer, 3.0m corridor between a fire hydrant and the curb, a 2.5m radius beside or behind a fire hydrant, 2.0m from any servicing/utility line or structure |

BELOW GRADE LANDSCAPE PLAN LEGEND

REFER TO CIVIL /CUP

- PG Proposed Coniferous Tree
- CR Proposed Deciduous Tree
- Proposed Planting Bed
- PS-76-101-TP- Circum Bike Rack by HAUSER Anchor to Concrete
- Fire Hydrant
- FD Siamese Connection
- LS Light Standard Base REFER TO TCR BY IFS
- Existing Tree to Remain
- Existing Tree to be Removed
- Protection for Existing Trees
- O/H Hydro Service

U/G Water Service
 U/G Storm Service
 U/G Sanitary Service

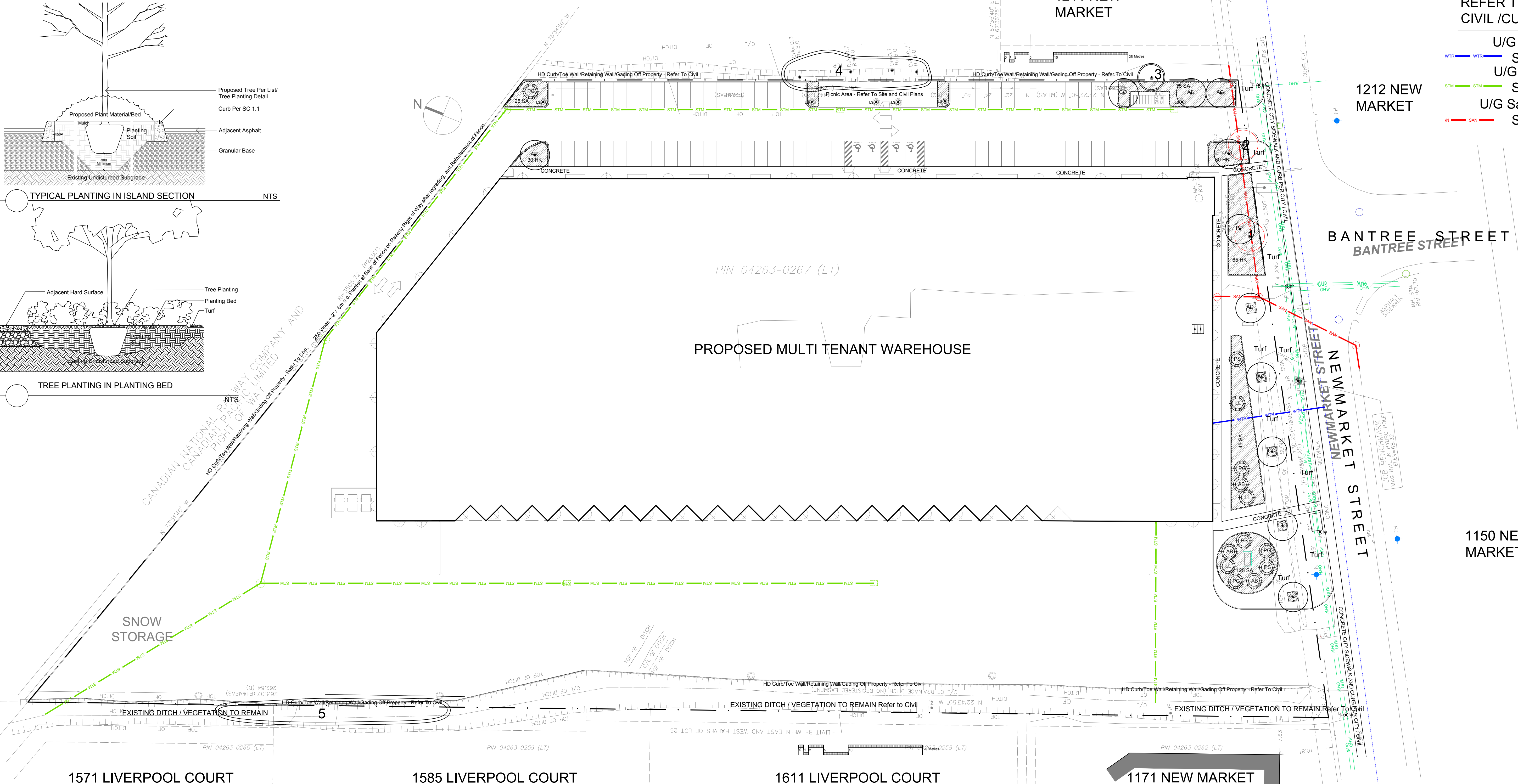

No.	Revision	Date
2	SECOND SUBMISSION SPC	OCTOBER 27 2021
1	FIRST SUBMISSION SPC	JULY 23 2021
0	REVIEW / COORDINATION	JULY 2021

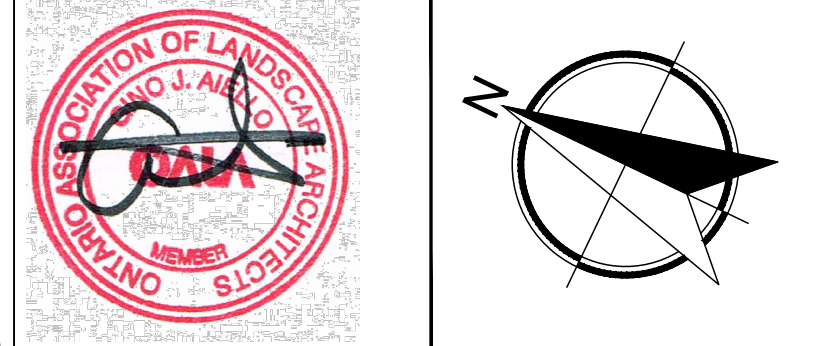

Property Owner: 1199 Newmarket Holdings LTD.
 A-3488 Ch. Cote-des-Neiges Montreal, Quebec H3H 2M6

Gino J. Aiello | landscape architect GJALA.com
 GJA Inc. Gino@GJALA.com (613) 852 1343
 110 Dabury Road Unit # 9 | Ottawa Ontario | K2T 0C2

Project: Multi Unit Warehouse
 1195 NEWMARKET STREET OTTAWA
 Drawing: Landscape Plan
 Date: JULY 2021
 Scale: 1:400
 City of Ottawa
 Dwg - 18551

Sheet Number: L1
 D07-12-21-0114