

No.	ISSUANCE	DATE
1	ISSUED FOR SITE PLAN CONTROL	2021-08-25
2	ISSUED FOR OWNER REVIEW	2021-11-22
3	ISSUED FOR MASS TIMBER BID	2021-11-26
4	ISSUED FOR OWNER REVIEW	2021-12-13
5	60% OWNER REVIEW SET	2022-01-20
6	90% OWNER REVIEW SET	2022-02-02
7	100% OWNER REVIEW SET	2022-03-01
8	ISSUED FOR SITE PLAN CONTROL	2022-03-04

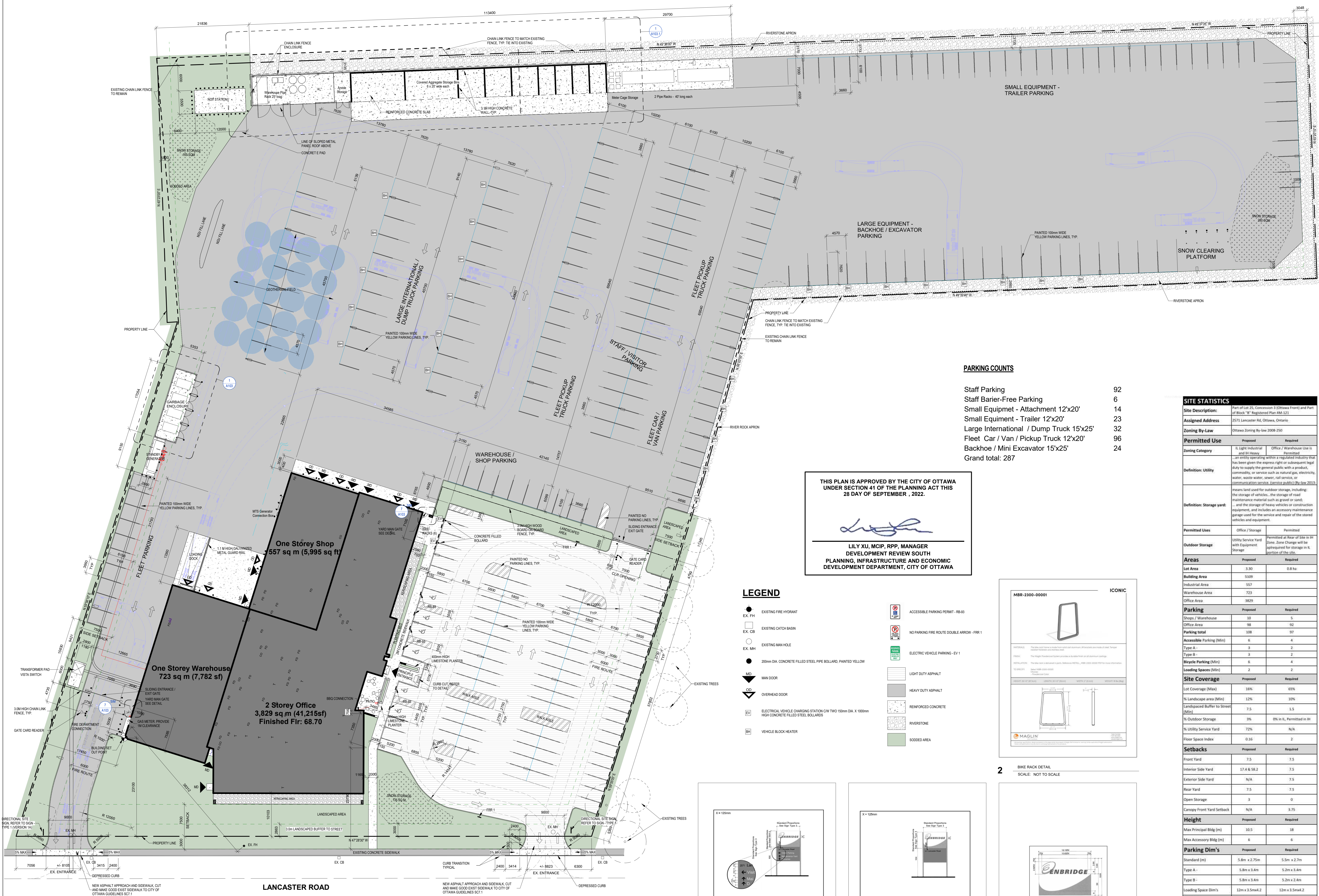

**PARKING COUNTS**

Staff Parking	92
Staff Barrier-Free Parking	6
Small Equipment - Attachment 12'x20'	14
Small Equipment - Trailer 12'x20'	23
Large International / Dump Truck 15'x25'	32
Fleet Car / Van / Pickup Truck 12'x20'	96
Backhoe / Mini Excavator 15'x25'	24
<b>Grand total:</b>	<b>287</b>

THIS PLAN IS APPROVED BY THE CITY OF OTTAWA UNDER SECTION 41 OF THE PLANNING ACT THIS 28 DAY OF SEPTEMBER, 2022.

LILY XU, MCIP, RPP, MANAGER  
DEVELOPMENT REVIEW SOUTH  
PLANNING, INFRASTRUCTURE AND ECONOMIC  
DEVELOPMENT DEPARTMENT, CITY OF OTTAWA

**LEGEND**

- EX. FH EXISTING FIRE HYDRANT
- EX. CB EXISTING CATCH BASIN
- EX. MH EXISTING MAN HOLE
- 200mm DIA. CONCRETE FILLED STEEL PIPE BOLLARD, PAINTED YELLOW
- MD MAN DOOR
- DD OVERHEAD DOOR
- EV ELECTRICAL VEHICLE CHARGING STATION (W/ TWO 1500mm DIA. X 1000mm HIGH CONCRETE FILLED STEEL BOLLARDS)
- BH VEHICLE BLOCK HEATER
- ACCESSIBLE PARKING PERMIT - RB-01
- NO PARKING FIRE ROUTE DOUBLE ARROW - FRR-1
- ELECTRIC VEHICLE PARKING - EV-1
- LIGHT DUTY ASPHALT
- HEAVY DUTY ASPHALT
- REINFORCED CONCRETE
- RIVERSTONE
- SOODED AREA

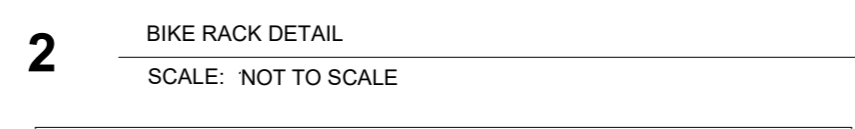
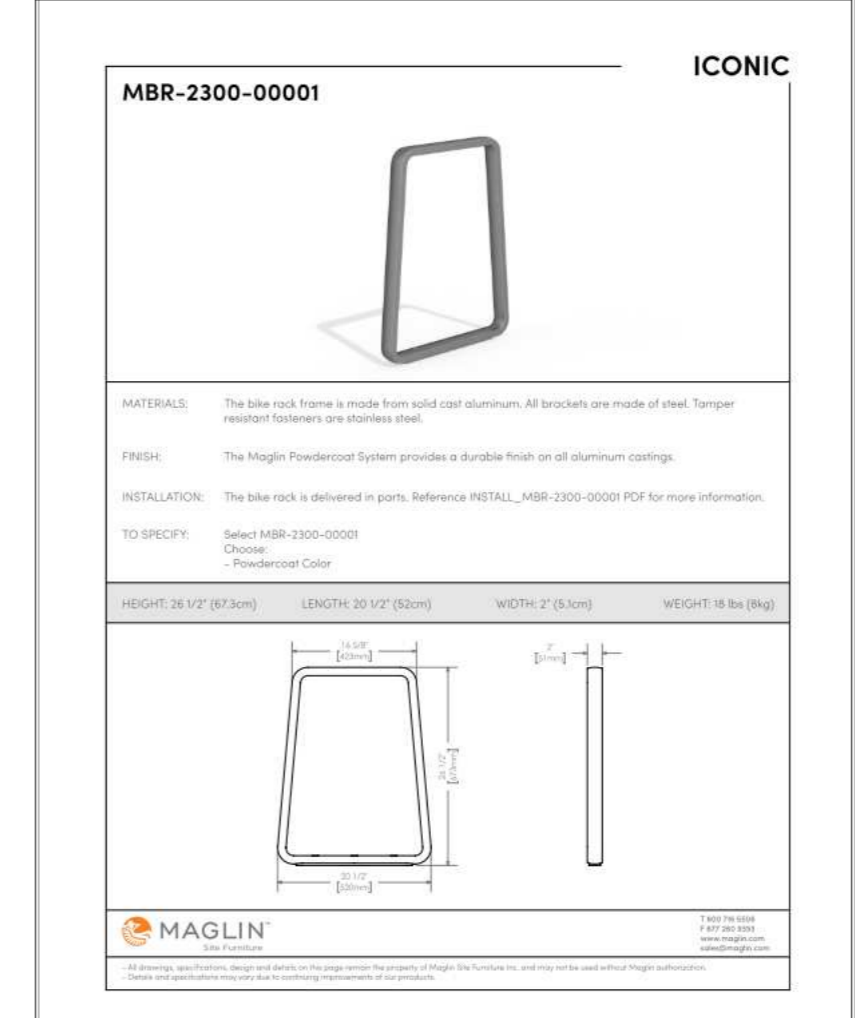

3 SIGN - TYPE 1  
SCALE: NOT TO SCALE

4 SIGN - TYPE 2  
SCALE: NOT TO SCALE

5 SIGN - TYPE 3  
SCALE: NOT TO SCALE

**SITE STATISTICS**

<b>Site Description:</b>	Part of Lot 25, Concession 8 (Ottawa Front) and Part of Block "B" Registered Plan 4M 123	
<b>Assigned Address:</b>	2571 Lancaster Rd, Ottawa, Ontario	
<b>Zoning By-Law:</b>	Ottawa Zoning By-law 2008-250	
<b>Permitted Use:</b>	Proposed	Required
<b>Zoning Category:</b>	Office / Warehouse Use Is Permitted	Office / Warehouse Use Is Permitted
<b>Definition: Utility:</b>	An entity operating within a regulated industry that has been given the express right or subsequent legal duty to supply the general public with a product, commodity, or service such as natural gas, electricity, water, waste water, sewer, rail service, or communication services. (Ontario public (R.S.O. 1990)	
<b>Definition: Storage yard:</b>	Means land used for outdoor storage, including the storage of vehicles...the storage of road maintenance material such as gravel or sand...and the storage of heavy vehicles or construction equipment, and includes an accessory maintenance garage used for the service and repair of the stored vehicles and equipment.	
<b>Permitted Uses:</b>	Office / Storage	Permitted
<b>Outdoor Storage:</b>	Utility Service Yard with Equipment Storage	Permitted at Rear of Site to Sit Zone. Zone Change will be required for storage in R portion of the site.
<b>Areas:</b>	Proposed	Required
<b>Lot Area:</b>	3.30	0.8 ha
<b>Building Area:</b>	5109	
<b>Industrial Area:</b>	557	
<b>Warehouse Area:</b>	723	
<b>Office Area:</b>	3829	
<b>Parking:</b>	Proposed	Required
<b>Shops / Warehouse:</b>	30	5
<b>Office Area:</b>	98	92
<b>Parking total:</b>	108	97
<b>Accessible Parking (Min):</b>	6	6
<b>Type A:</b>	3	2
<b>Type B:</b>	3	2
<b>Bicycle Parking (Min):</b>	5	4
<b>Loading Spaces (Min):</b>	2	2
<b>Site Coverage:</b>	Proposed	Required
<b>Lot Coverage (Max):</b>	18%	65%
<b>% Landscape area (Min):</b>	12%	10%
<b>Landscape Buffer to Street (Min):</b>	7.5	3.5
<b>% Outdoor Storage:</b>	3%	0% in R, Permitted in B1
<b>% Utility Service Yard:</b>	72%	N/A
<b>Floor Space Index:</b>	0.16	2
<b>Setbacks:</b>	Proposed	Required
<b>Front Yard:</b>	7.5	7.5
<b>Interior Side Yard:</b>	17.4 & 58.2	7.5
<b>Exterior Side Yard:</b>	N/A	7.5
<b>Rear Yard:</b>	7.5	7.5
<b>Open Storage:</b>	3	0
<b>Canopy Front Yard Setback:</b>	N/A	3.75
<b>Height:</b>	Proposed	Required
<b>Max Principal Bldg (m):</b>	10.5	18
<b>Max Accessory Bldg (m):</b>	6	6
<b>Parking Dim's:</b>	Proposed	Required
<b>Standard (m):</b>	5.8m x 2.75m	5.5m x 2.7m
<b>Type A:</b>	5.8m x 3.4m	5.2m x 3.4m
<b>Type B:</b>	5.8m x 3.4m	5.2m x 2.4m
<b>Loading Space Dim's:</b>	12m x 3.5m x 4.2	12m x 3.5m x 4.2
<b>Bicycle Space:</b>	3.8m x 0.6m	3.8m x 0.6m
<b>Conservation Authority:</b>	Riverbank Conservation Authority	Not a Regulated Zone

ENBRIDGE GAS  
500 CONSUMERS ROAD, NORTH YORK, ON, M2J 1P8  
TEL: 1-877-382-1434

OTTAWA OPERATIONS CENTRE  
2571 LANCASTER ROAD, OTTAWA, ON, K1B 4L5

ARCHITECTURAL SITE PLAN

**WALTER FEDY**  
KITCHENER HAMILTON 800.665.1378 walterfedy.com



REPRODUCTION OR DISTRIBUTION FOR PURPOSES OTHER THAN AUTHORIZED BY WALTER FEDY IS PROHIBITED. CONTRACTORS SHALL VERIFY AND BE RESPONSIBLE FOR ALL DIMENSIONS AND CONDITIONS ON THE JOB AND REPORT ANY VARIATIONS FROM THE CONTRACTING AND CONDITIONS SPECIFIC TO THE DRAWINGS TO WALTER FEDY IMMEDIATELY UPON DISCOVERY.



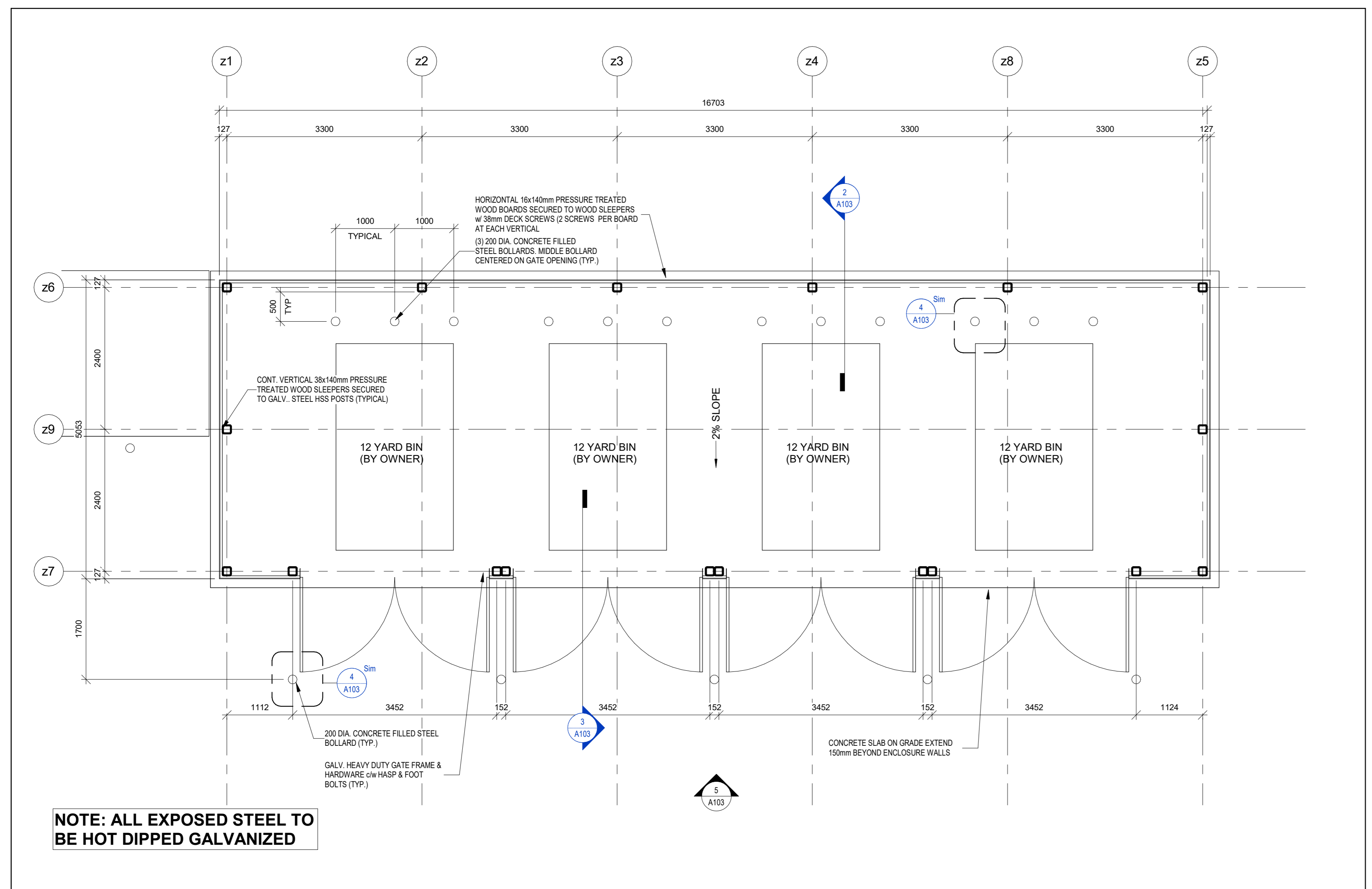

1 GARBAGE ENCLOSURE PLAN  
Scale: 1:50

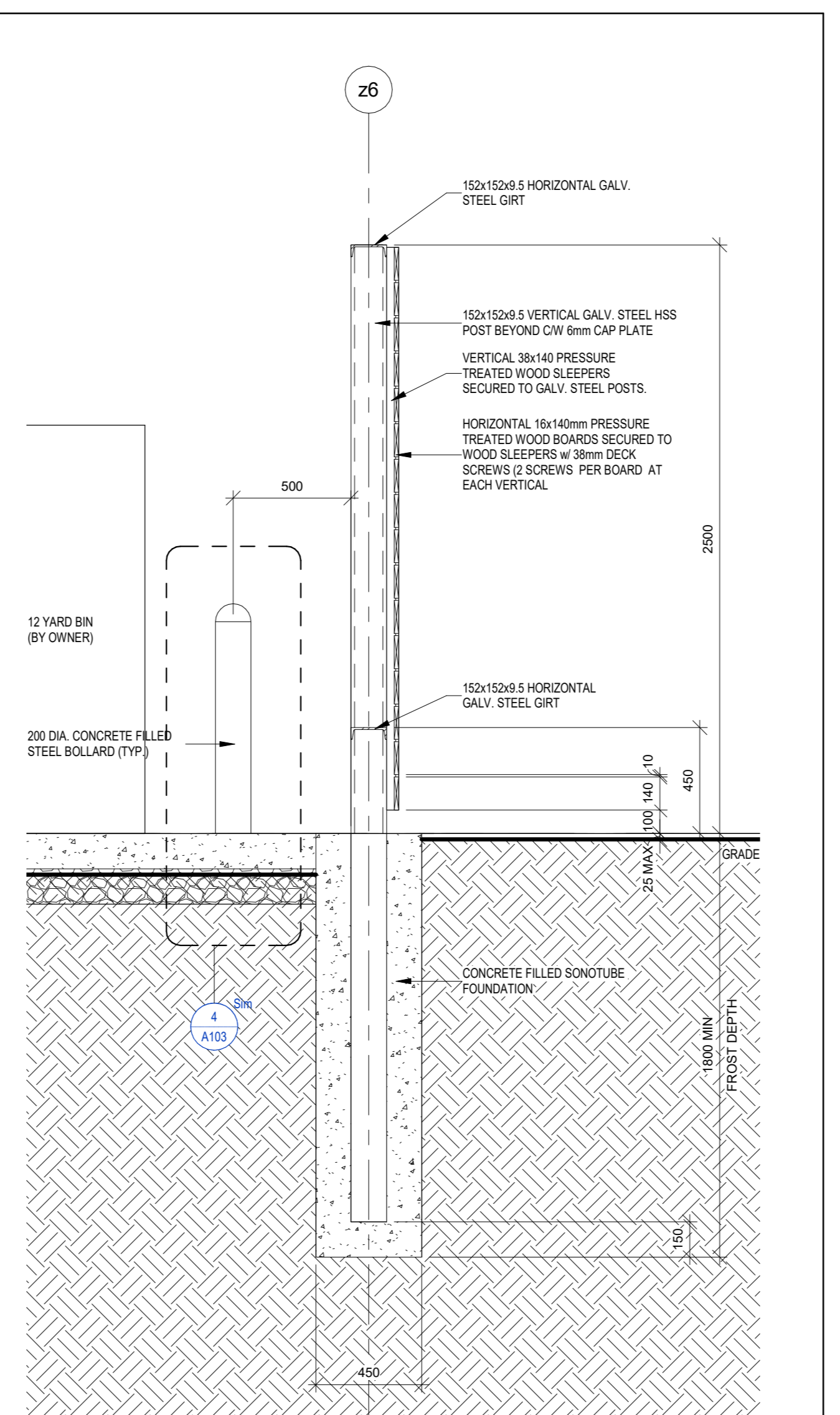

2 GARBAGE ENCLOSURE SECTION  
Scale: 1:20

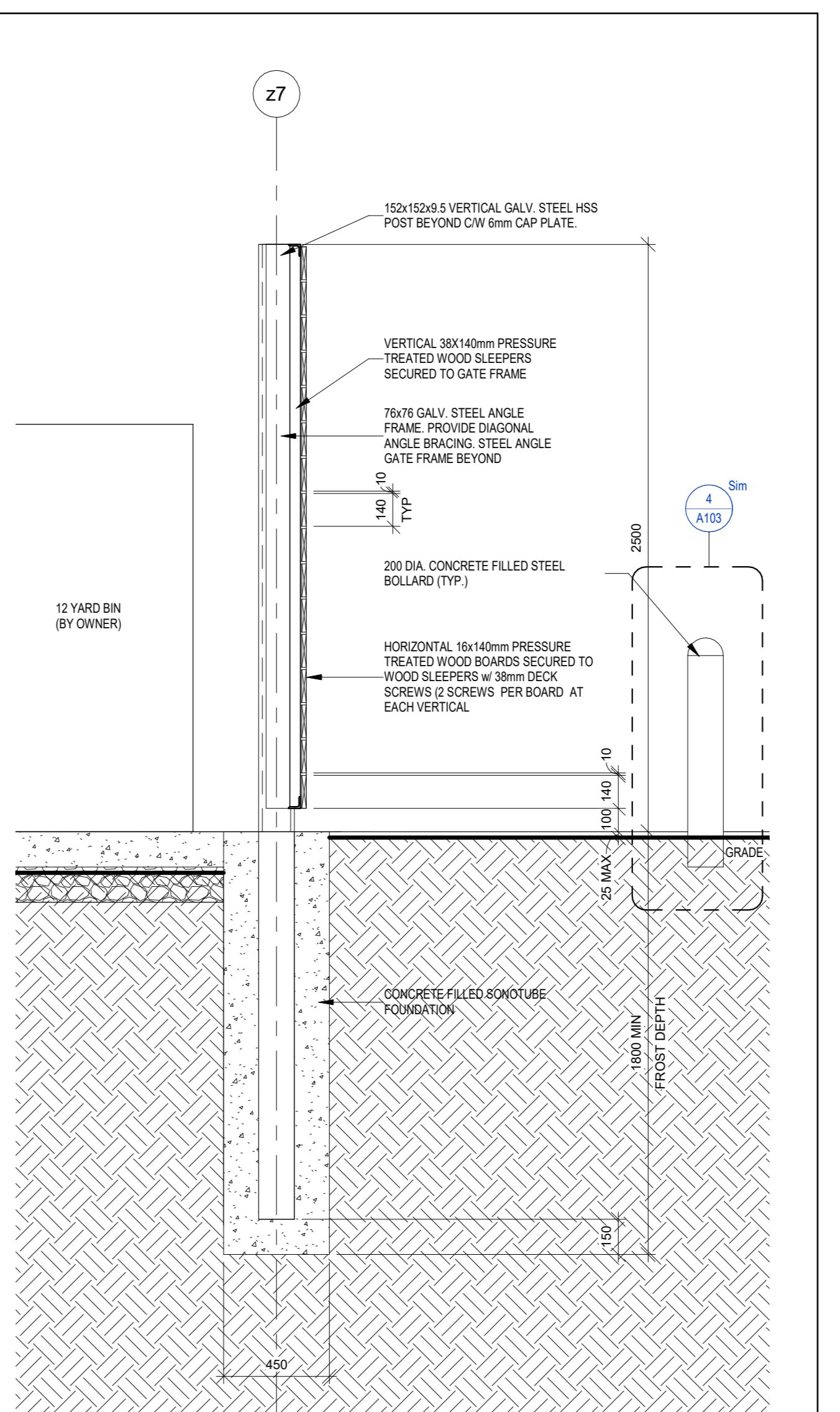

3 GARBAGE ENCLOSURE SECTION  
Scale: 1:20

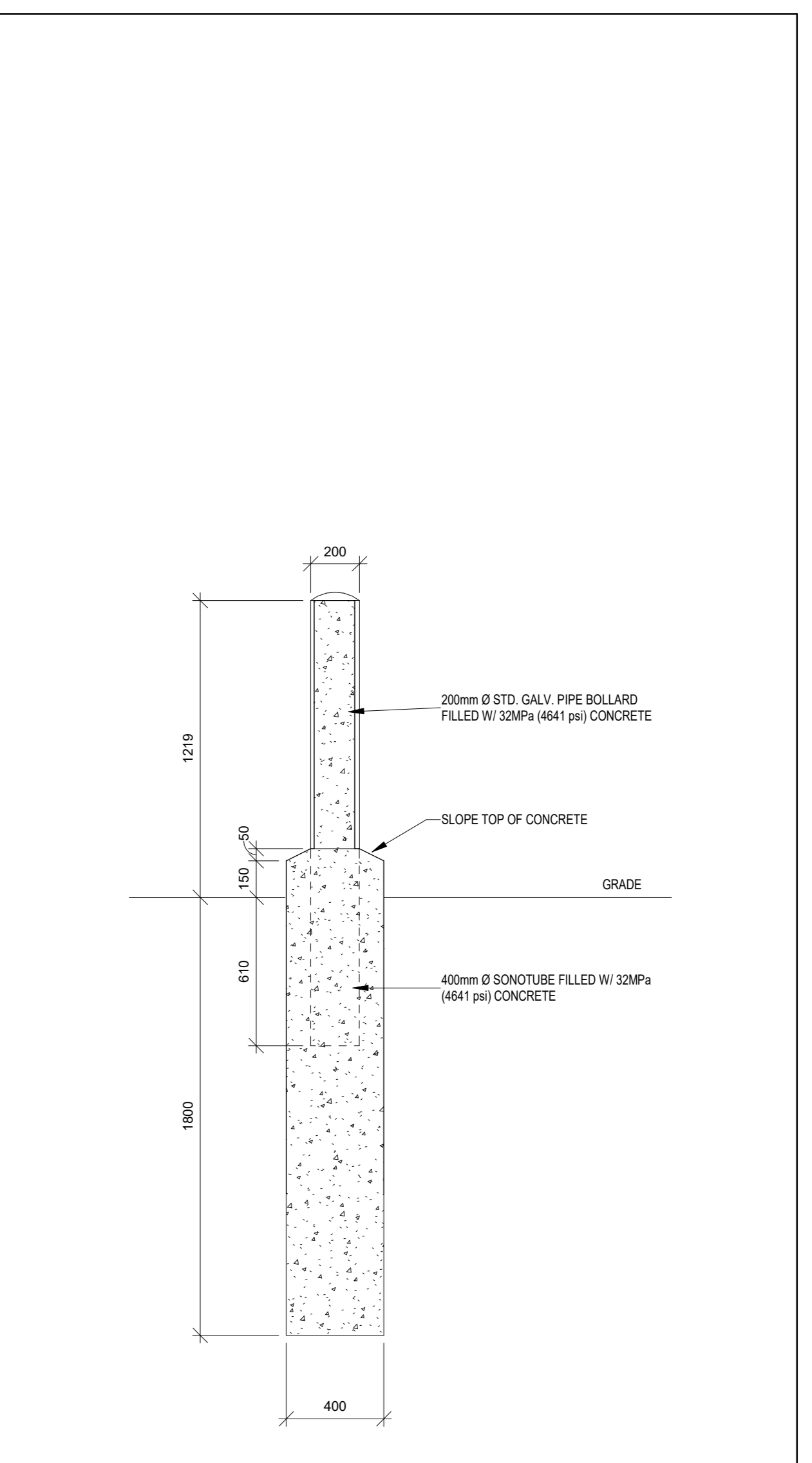

4 CONCRETE FILLED PIPE BOLLARD  
Scale: 1:20

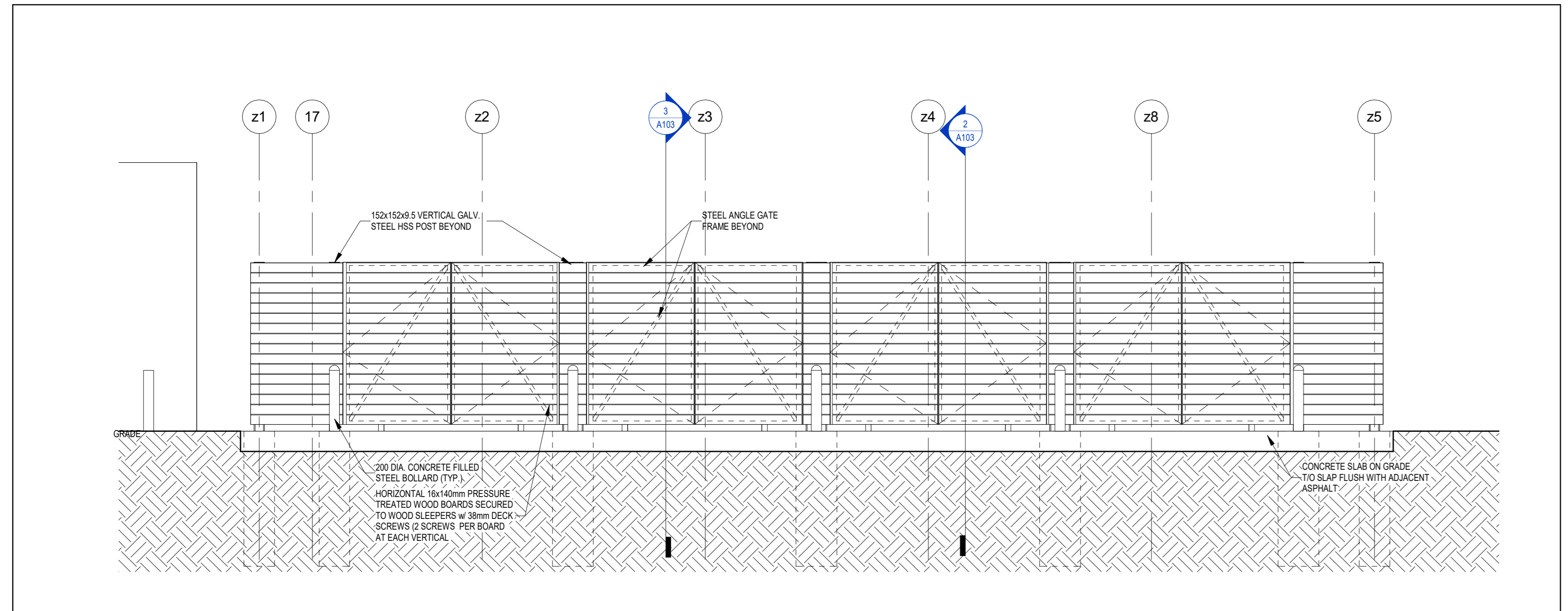

5 GARBAGE ENCLOSURE ELEVATION  
Scale: 1:50

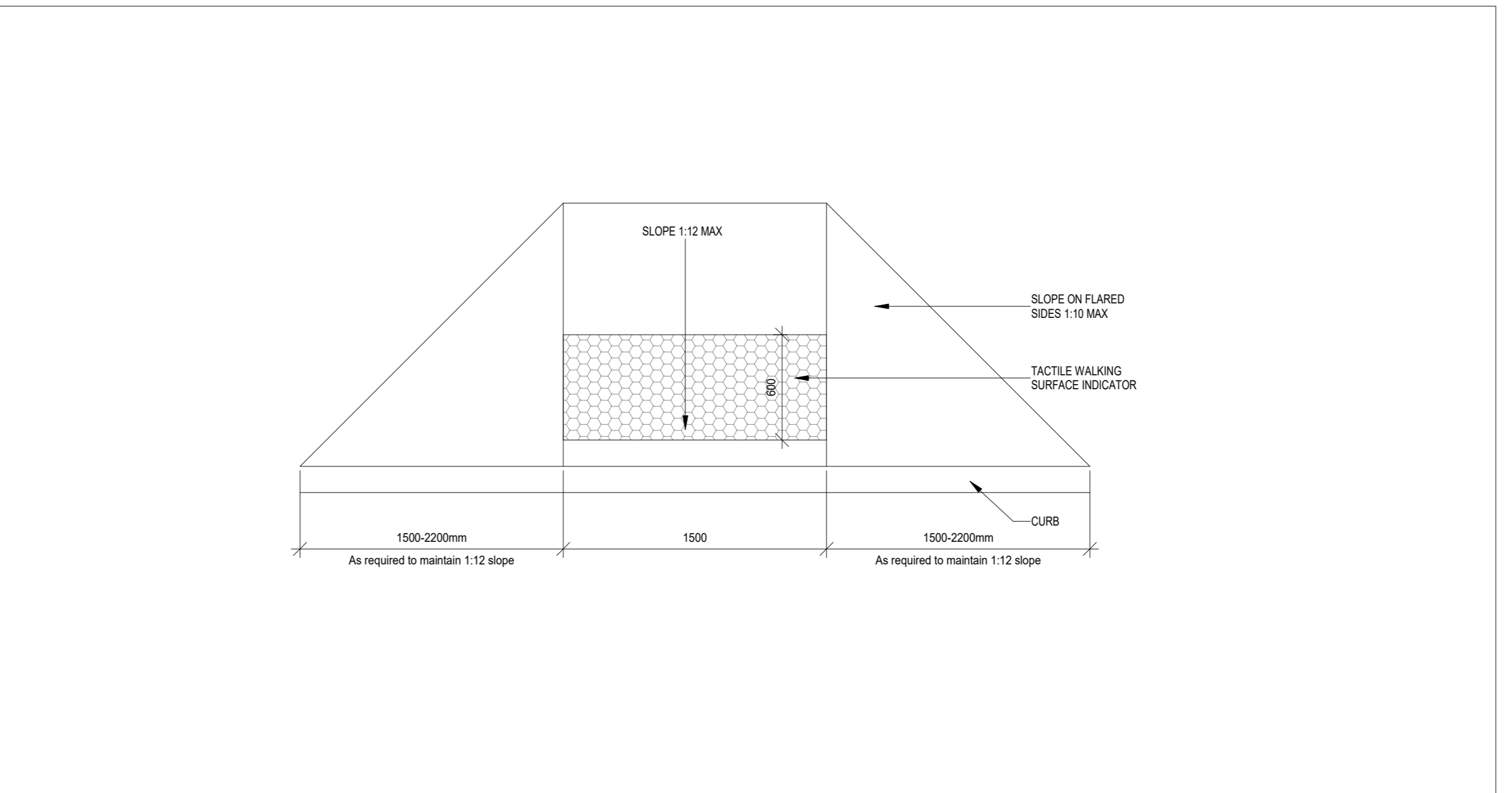

6 BARRIER FREE CURB CUT  
Scale: 1:25

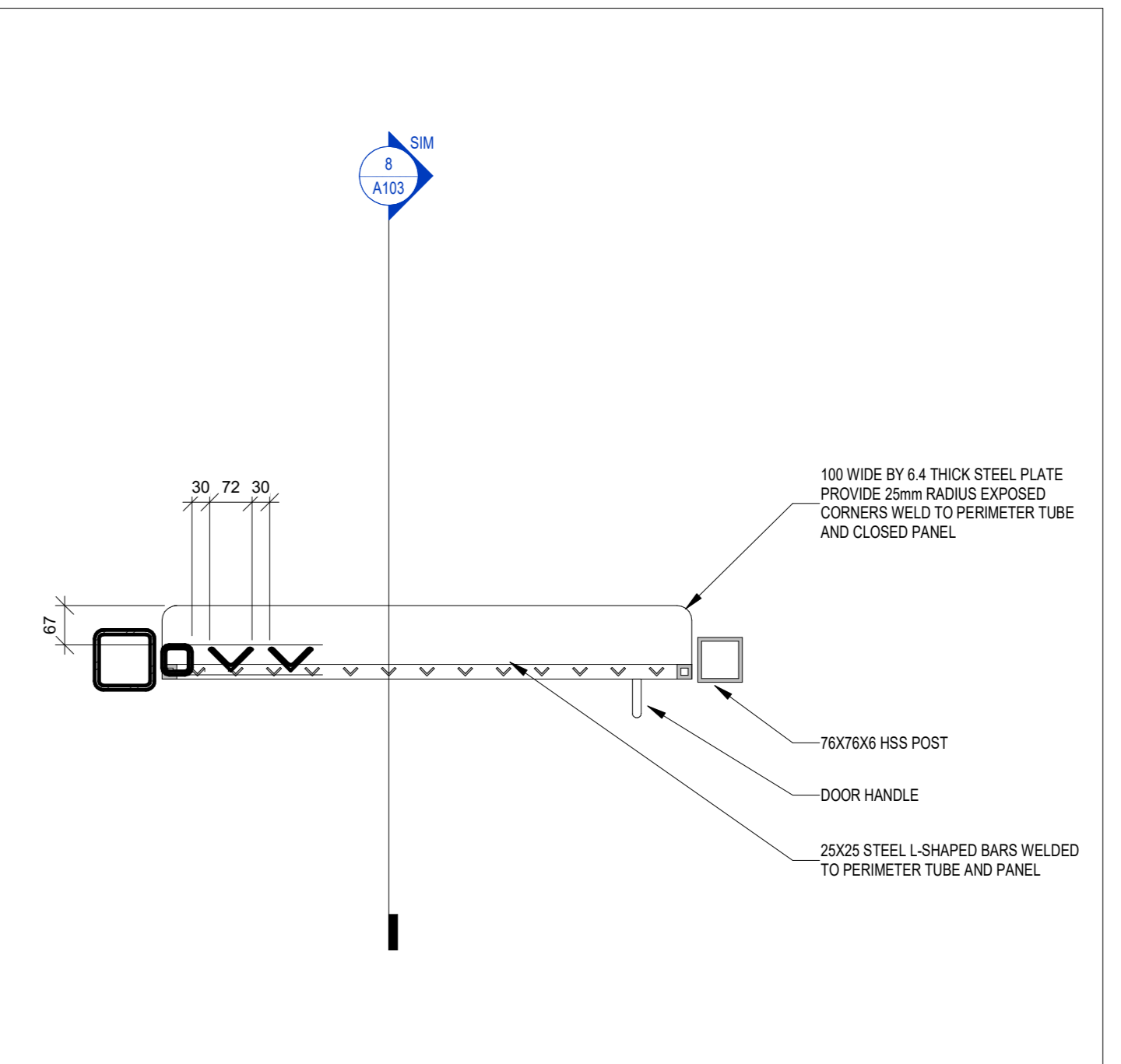

7 PLAN - YARD GATE  
Scale: 1:10

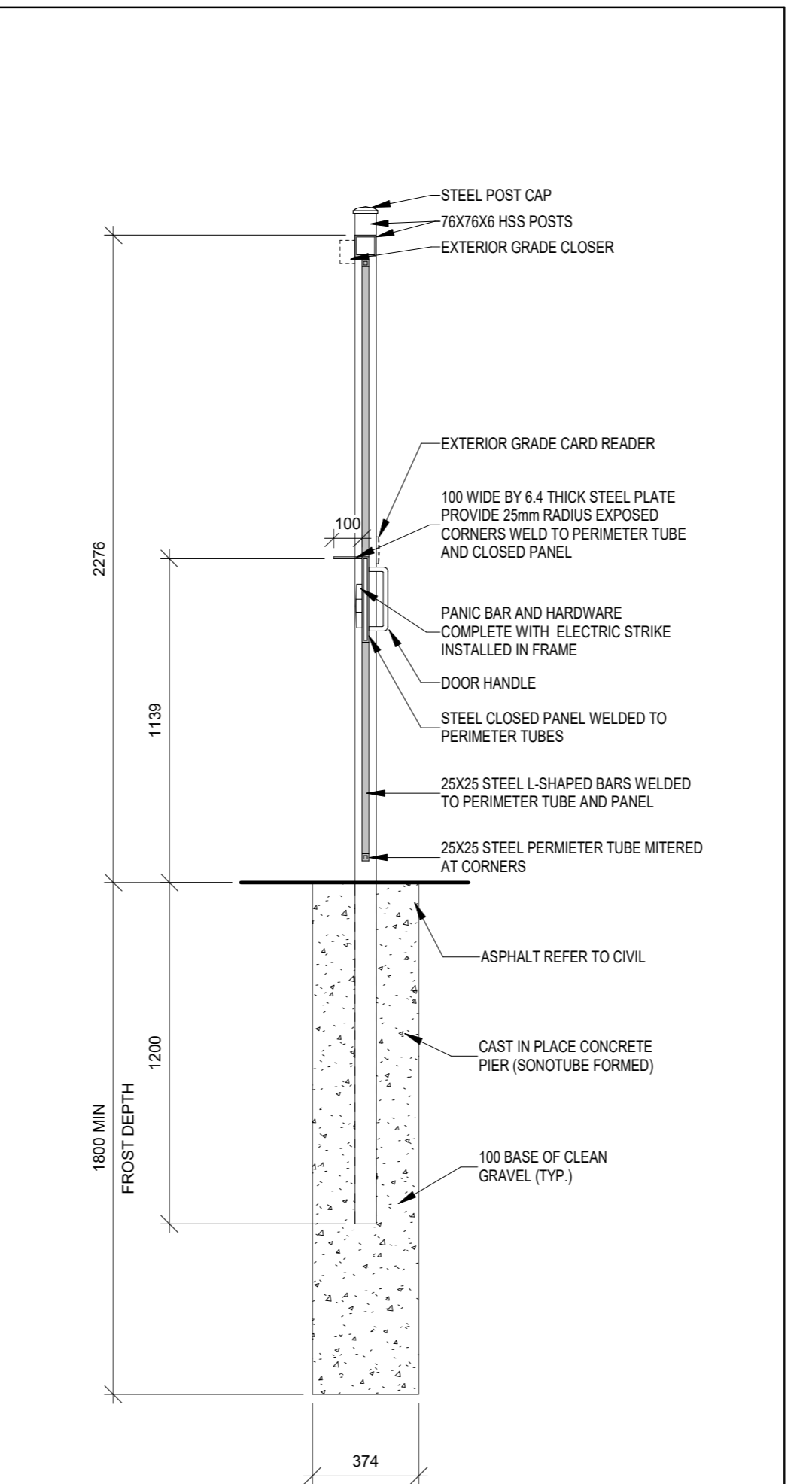
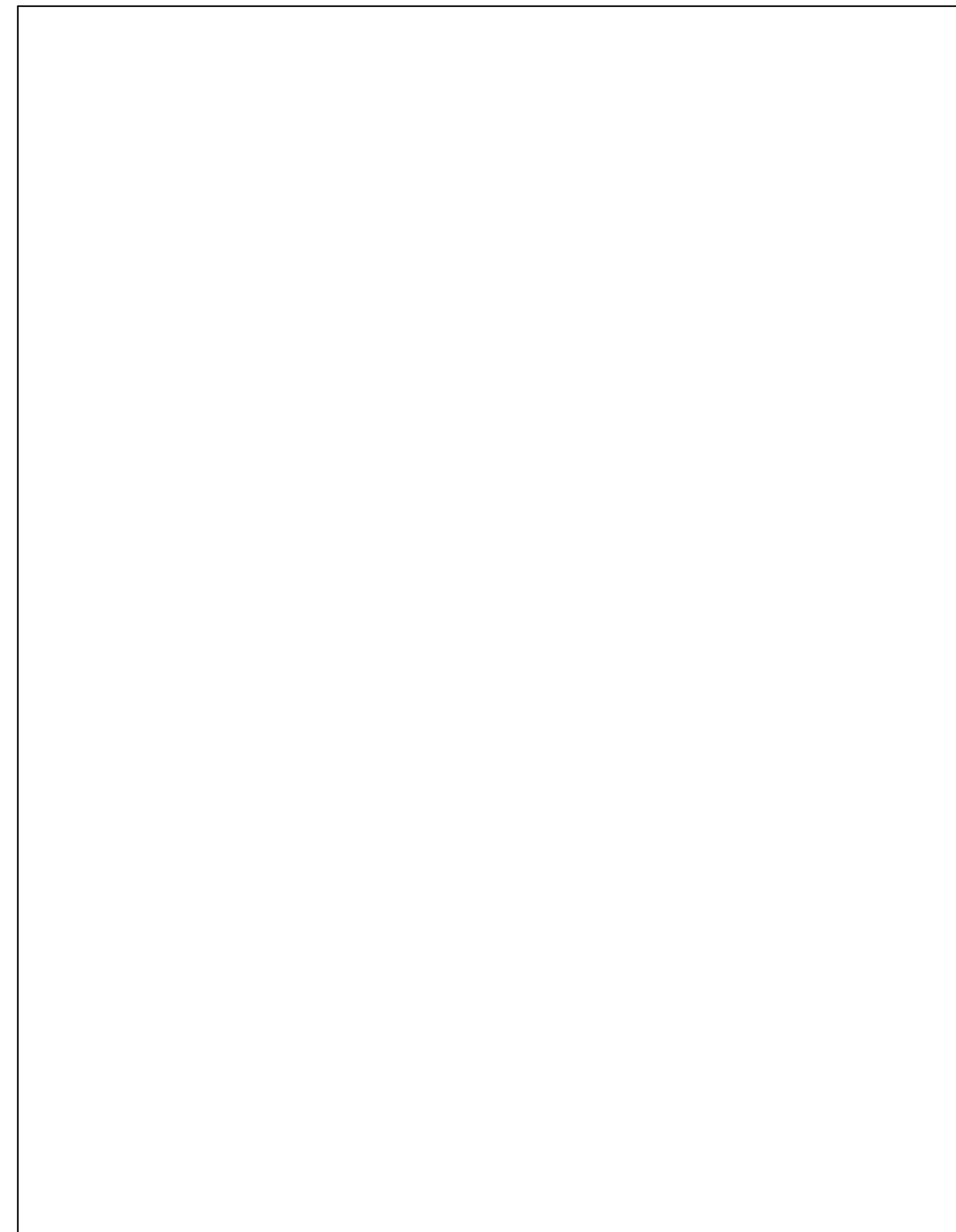

8 SECTION - YARD GATE  
Scale: 1:20

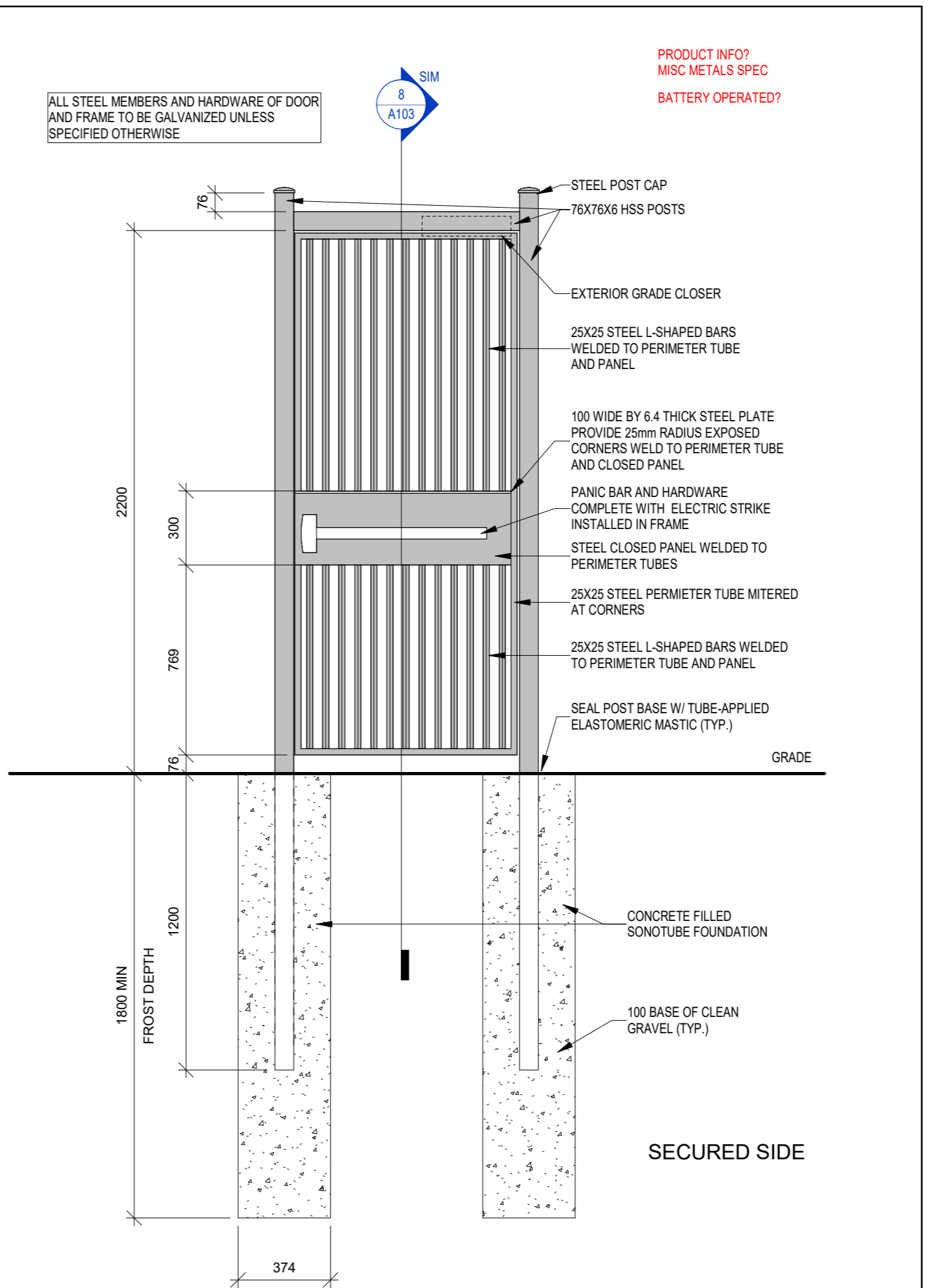

9 ELEVATION - YARD GATE  
Scale: 1:20

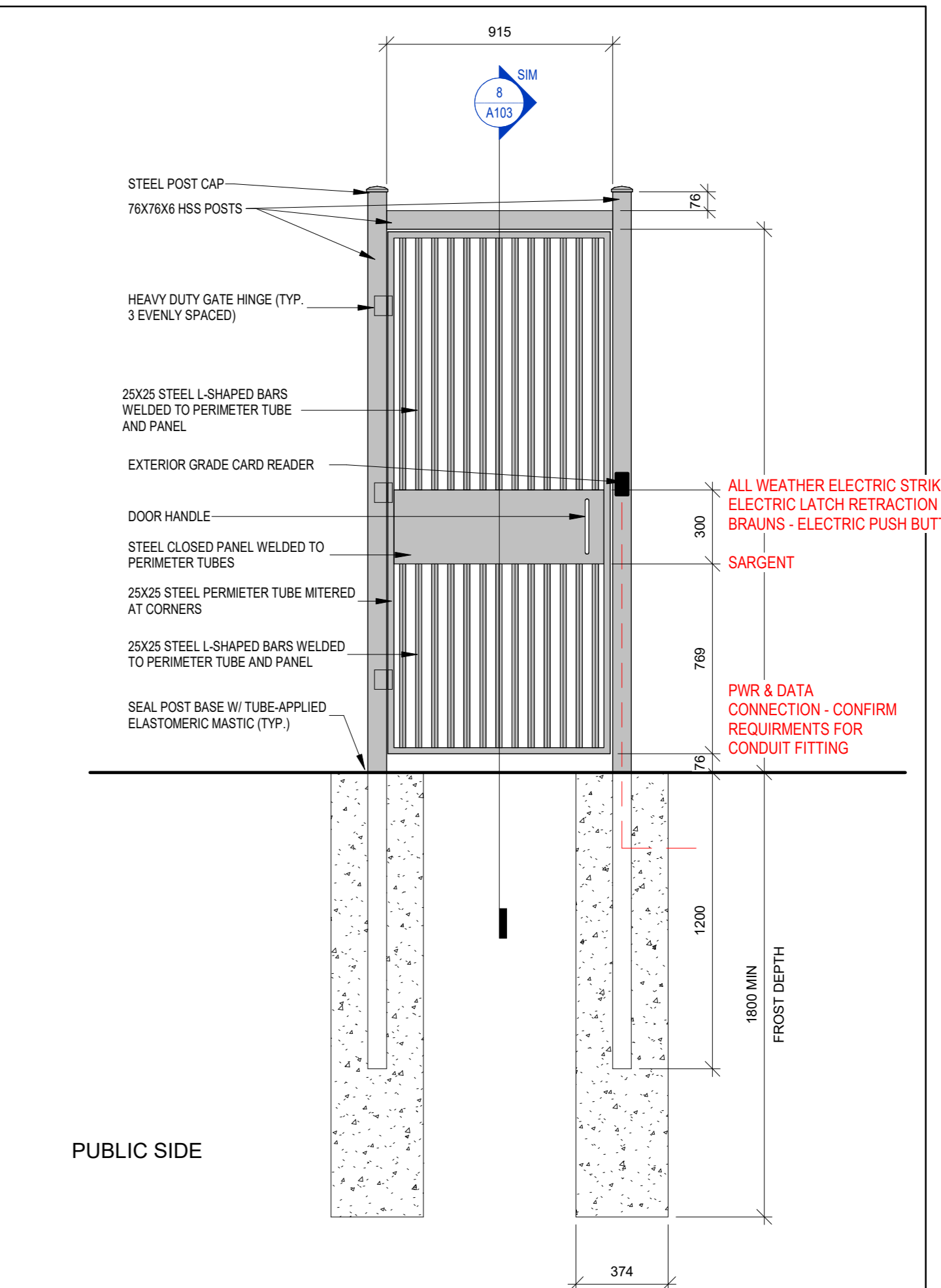

10 SECTION - YARD GATE  
Scale: 1:20

No.	ISSUANCE	DATE
1	ISSUED FOR SITE PLAN CONTROL	2021-08-25
2	ISSUED FOR OWNER REVIEW	2021-12-13
3	60% OWNER REVIEW SET	2022-01-20
4	90% OWNER REVIEW SET	2022-02-02
5	100% OWNER REVIEW SET	2022-03-01
6	ISSUED FOR SITE PLAN CONTROL	2022-03-04

CLIENT  
**ENBRIDGE GAS**  
500 CONSUMERS ROAD, NORTH YORK, ON, M2J 1P8  
Tel: 1-877-982-7434

PROJECT  
**OTTAWA OPERATIONS CENTRE**  
2571 LANCASTER ROAD, OTTAWA, ON, K1B 4L5

TITLE  
**MISCELLANEOUS SITE DETAILS**

**WALTERFEDY**  
KITCHENER HAMILTON 800.665.1378 walterfedy.com



REPRODUCTION OR DISTRIBUTION FOR PURPOSES OTHER THAN AUTHORIZED BY THE TERMS OF CONTRACT IS STRICTLY PROHIBITED AND THE USER SHALL BE RESPONSIBLE FOR ALL DIMENSIONS AND CONDITIONS ON THE JOB AND REPORT ANY VARIATIONS FROM THE DIMENSIONS AND CONDITIONS SHOWN ON DRAWINGS TO WALTERFEDY. DO NOT SCALE THIS DRAWING.

SCALE:	As Indicated	SHEET NO.:	
DATE:	07/14/21		
PROJECT NO.:	2020-0666-10		
FILE:			
DRAWN BY:	Author		
CHECKED BY:	Checker		

**A103**



NOTE: ALL EXPOSED STEEL TO BE HOT DIPPED GALVANIZED

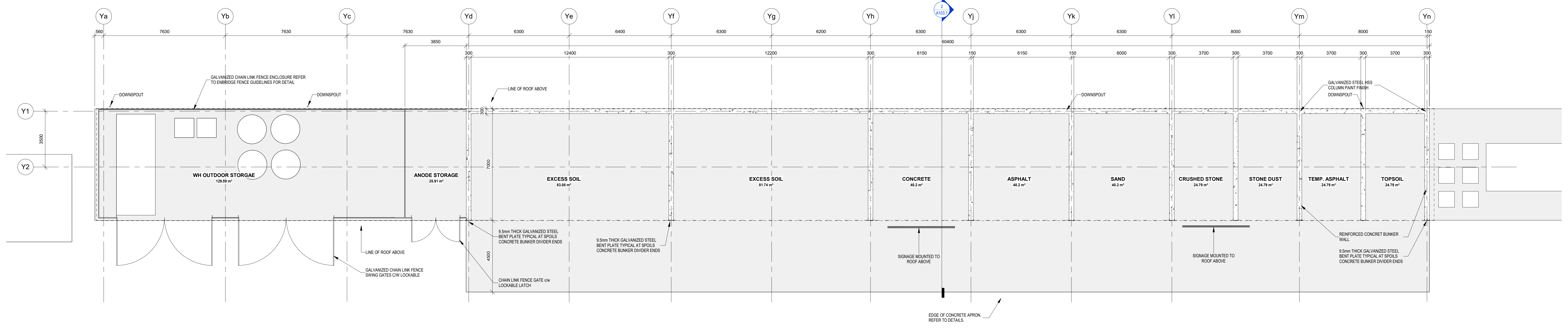

1 PLAN : COVERED SPOILS STORAGE  
 Scale: 1 : 100

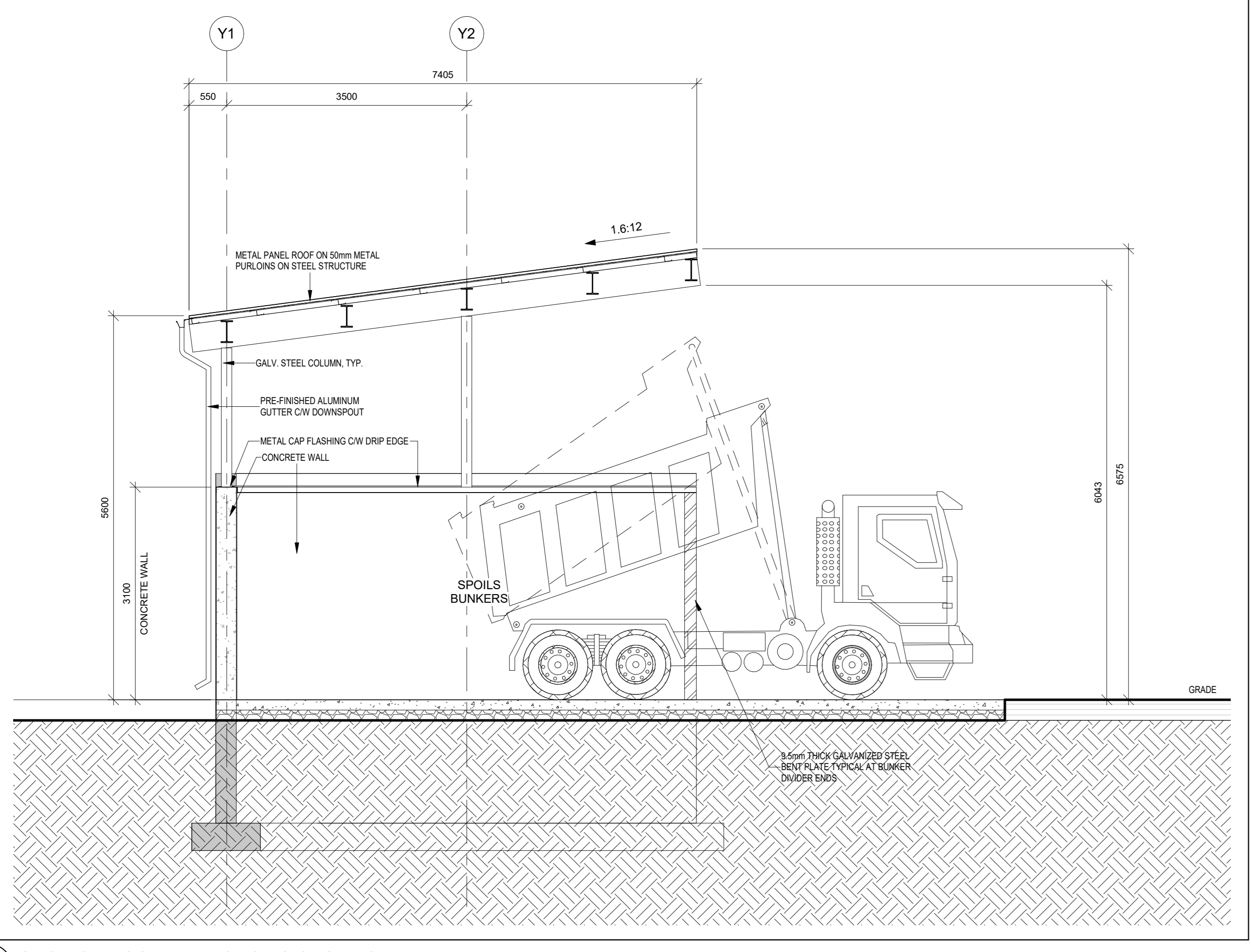

2 SECTION : COVERED SPOILS STORAGE  
 Scale: 1 : 50

No.	ISSUANCE	DATE
1	ISSUED FOR OWNER REVIEW	2021-12-13
2	90% OWNER REVIEW SET	2022-02-02
3	100% OWNER REVIEW SET	2022-03-01
4	ISSUED FOR SITE PLAN CONTROL	2022-03-04

CLIENT  
**ENBRIDGE GAS**  
 500 CONSUMERS ROAD, NORTH YORK, ON, M2J 1P8  
 Tel: 1-877-982-7434

PROJECT  
**OTTAWA OPERATIONS CENTRE**  
 2571 LANCASTER ROAD, OTTAWA, ON, K1B 4L5

TITLE  
**MISCELLANEOUS SITE DETAILS**

**WALTERFEDY**  
 KITCHENER HAMILTON 800.665.1378 walterfedy.com



REPRODUCTION OR DISTRIBUTION FOR PURPOSES OTHER THAN AUTHORIZED BY WALTERFEDY OR A LICENSED CONTRACTOR SHALL BE PROHIBITED AND BE RESPONSIBLE FOR ALL DIMENSIONS AND CONDITIONS ON THE JOB AND REPORT ANY VARIATIONS FROM THE DIMENSIONS AND CONDITIONS SHOWN ON DRAWINGS TO WALTERFEDY. DO NOT SCALE THIS DRAWING.

COPYRIGHT © 2021 Walterfedy Inc.

SCALE: As Indicated SHEET NO: A103.1  
 DATE: 07/14/21  
 PROJECT NO: 2020-0666-10  
 FILE:  
 DRAWN BY: Author  
 CHECKED BY: Checker



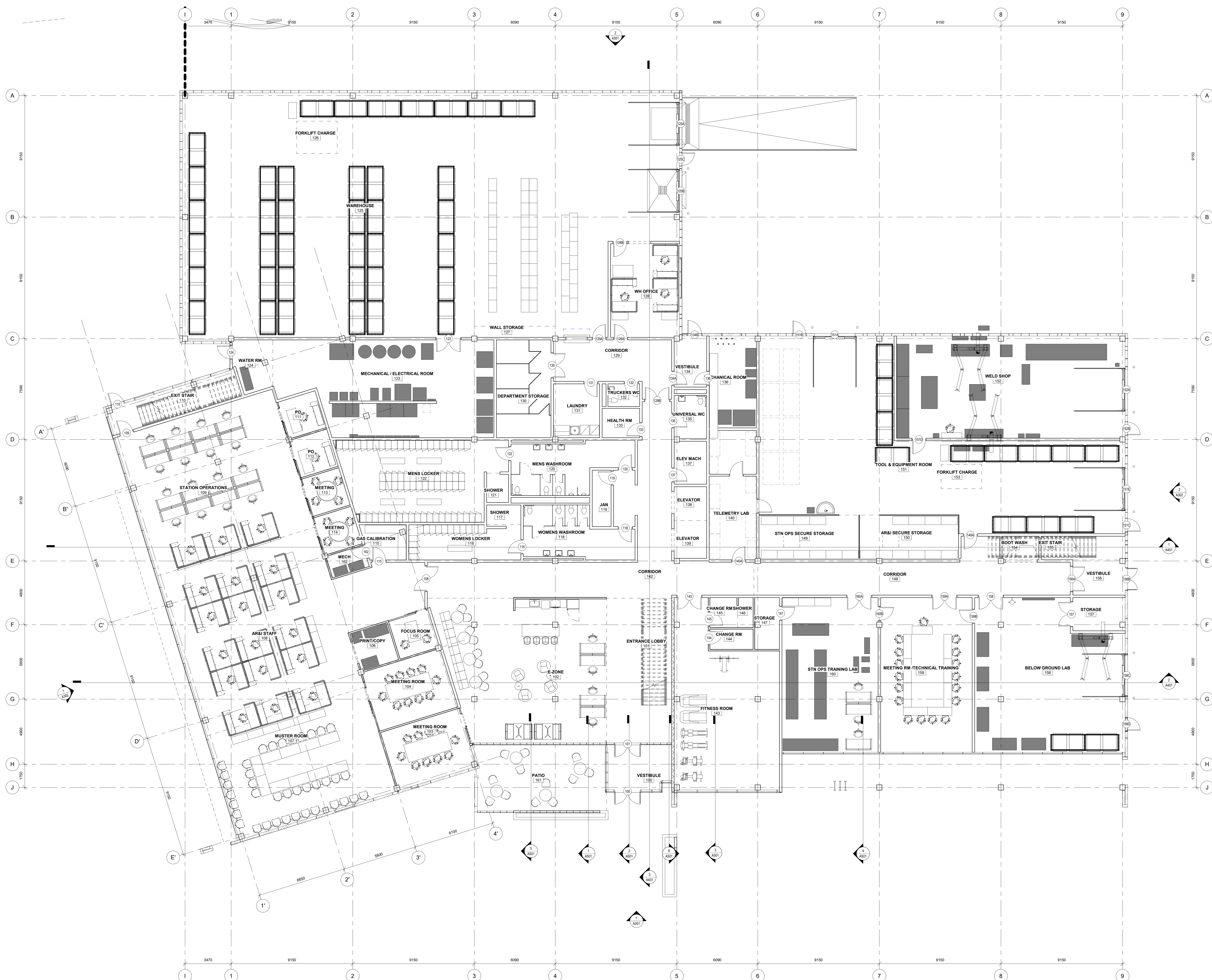

**GROUND FLOOR ROOM LEGEND**

- 100 VESTIBULE
- 101 ENTRANCE LOBBY
- 102 E-ZONE
- 103 MEETING ROOM
- 104 MEETING ROOM
- 105 FOCUS ROOM
- 106 PRINT/COPY
- 107 MUSTER ROOM
- 108 AR&I STAFF
- 109 STATION OPERATIONS
- 110 EXIT STAIR
- 111 PO
- 112 PO
- 113 MEETING
- 114 MEETING
- 115 GAS CALIBRATION
- 116 WOMENS LOCKER
- 117 SHOWER
- 118 WOMENS WASHROOM
- 119 JAN
- 120 MENS WASHROOM
- 121 SHOWER
- 122 MENS LOCKER
- 123 MECHANICAL / ELECTRICAL ROOM
- 124 WATER RM
- 125 WAREHOUSE
- 126 FORKLIFT CHARGE
- 127 WALL STORAGE
- 128 WH OFFICE
- 129 CORRIDOR
- 130 DEPARTMENT STORAGE
- 131 LAUNDRY
- 132 TRUCKERS WC
- 133 HEALTH RM
- 134 VESTIBULE
- 135 UNIVERSAL WC
- 136 MECHANICAL ROOM
- 137 ELEV MACH
- 138 ELEVATOR
- 139 ELEVATOR
- 140 TELEMETRY LAB
- 142 CORRIDOR
- 143 FITNESS ROOM
- 144 CHANGE RM
- 145 CHANGE RM
- 146 SHOWER
- 147 STORAGE
- 148 CORRIDOR
- 149 STN OPS SECURE STORAGE
- 150 AR&I SECURE STORAGE
- 151 TOOL & EQUIPMENT ROOM
- 152 WELD SHOP
- 153 FORKLIFT CHARGE
- 154 BOOT WASH
- 155 EXIT STAIR
- 156 VESTIBULE
- 157 STORAGE
- 158 BELOW GROUND LAB
- 159 MEETING RM / TECHNICAL TRAINING
- 160 STN OPS TRAINING LAB
- 161 PATIO
- 162 MECH
- 163 DOORWAY RM

CLIENT: ENBRIDGE GAS  
 PROJECT: OTTAWA OPERATIONS CENTRE  
 2571 LANCASTER ROAD, OTTAWA, ON  
 TITLE: GROUND FLOOR PLAN  
 WALTERFEDY ARCHITECTS  
 KITCHENER HAMILTON 800.665.1378 walterfedycan.com

No.	ISSUANCE	DATE
1	ISSUED FOR SITE PLAN CONTROL	2021-08-25

REPRODUCTION OR DISTRIBUTION FOR PURPOSES OTHER THAN AUTHORIZED BY WALTERFEDY ARCHITECTS IS PROHIBITED. CONTRACTORS SHALL VERIFY AND BE RESPONSIBLE FOR ALL DIMENSIONS AND CONDITIONS ON THE JOB AND REPORT ANY VARIATIONS FROM THE DIMENSIONS AND CONDITIONS SHOWN ON DRAWINGS TO WALTERFEDY ARCHITECTS IMMEDIATELY UPON DISCOVERY.

SCALE: As Indicated SHEET NO: A210  
 DATE: 2021-08-25  
 PROJECT NO: 2020-0666-10  
 FILE:  
 DRAWN BY: NRC, CE  
 CHECKED BY: SL, NRC



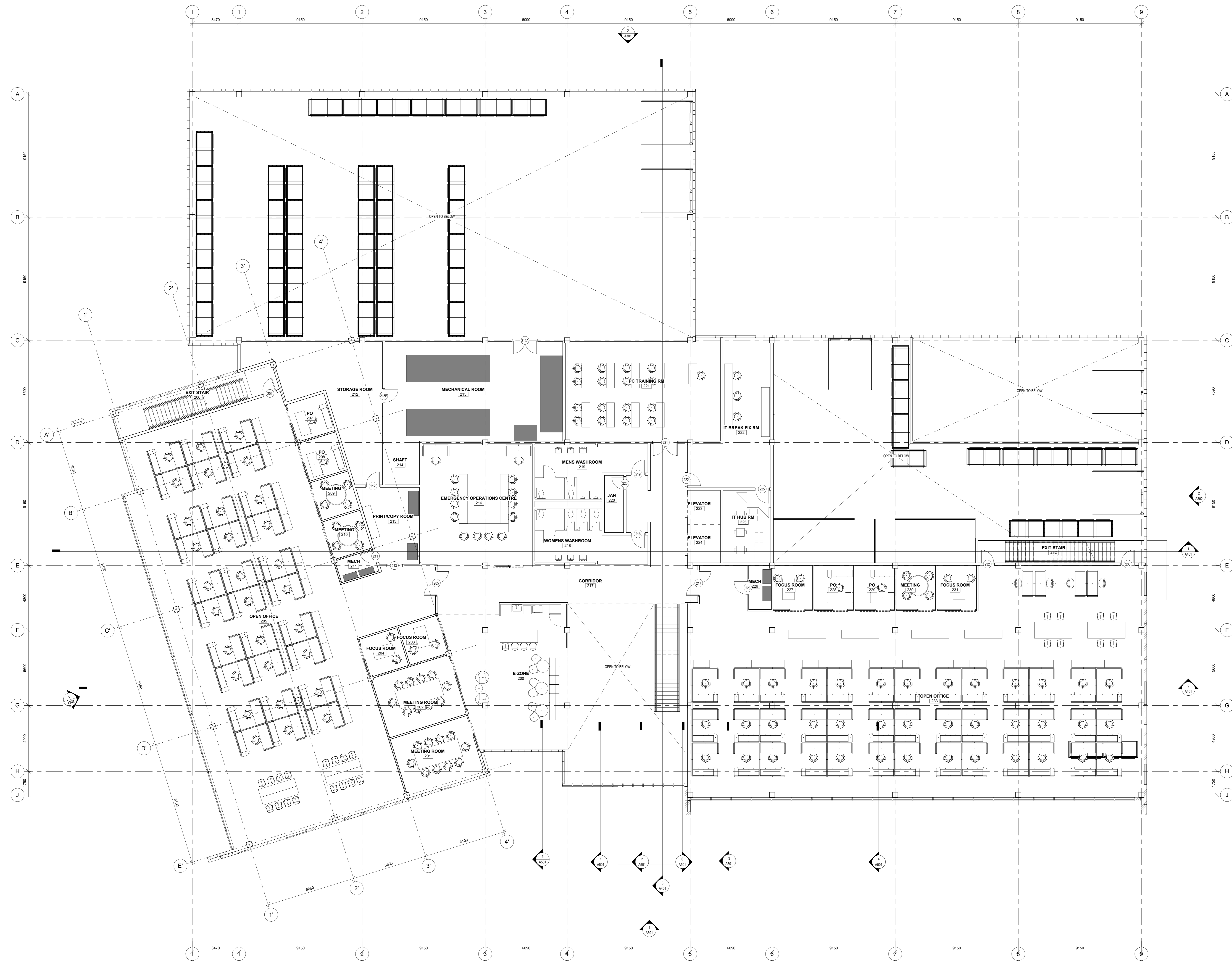

**SECOND FLOOR ROOM LEGEND**

200	E-ZONE
201	MEETING ROOM
202	MEETING ROOM
203	FOCUS ROOM
204	FOCUS ROOM
205	OPEN OFFICE
206	EXIT STAIR
207	PO
208	PO
209	MEETING
210	MEETING
211	MECH
212	STORAGE ROOM
213	PRINT/COPY ROOM
214	SHaft
215	MECHANICAL ROOM
216	EMERGENCY OPERATIONS CENTRE
217	CORRIDOR
218	WOMENS WASHROOM
219	MENS WASHROOM
220	JAN
221	PC TRAINING RM
222	IT BREAK FIX RM
223	ELEVATOR
224	ELEVATOR
225	IT HUB RM
226	MECH
227	FOCUS ROOM
228	PO
229	PO
230	MEETING
231	FOCUS ROOM
232	EXIT STAIR
233	OPEN OFFICE



CLIENT LOGO

KEY PLAN

TRUE NORTH PROJECT NORTH

No.	ISSUANCE	DATE
1	ISSUED FOR SITE PLAN CONTROL	2021-08-25

CLIENT  
**ENBRIDGE GAS**

500 CONSUMERS ROAD, NORTH YORK, ON

PROJECT  
**OTTAWA OPERATIONS CENTRE**

2571 LANCASTER ROAD, OTTAWA, ON

TITLE  
**SECOND FLOOR PLAN**

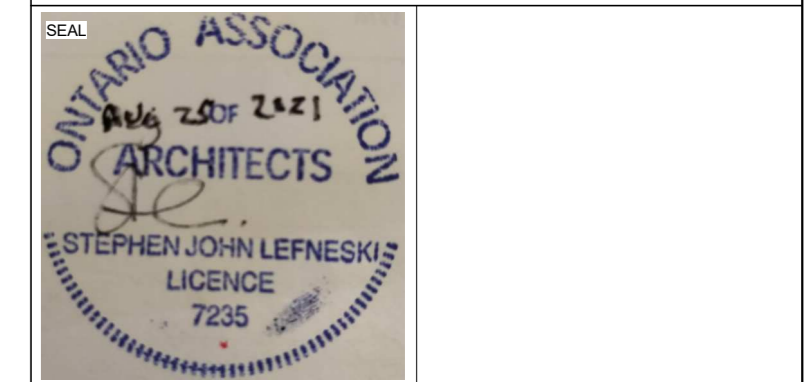

REPRODUCTION OR DISTRIBUTION FOR PURPOSES OTHER THAN AUTHORIZED BY WALTERFEDY ARCHITECTS IS PROHIBITED. CONTRACTORS SHALL VERIFY AND BE RESPONSIBLE FOR ALL DIMENSIONS AND CONDITIONS ON THE JOB AND REPORT ANY VARIATIONS FROM THE DRAWINGS AND CONDITIONS SHOWN ON DRAWINGS TO WALTERFEDY. DO NOT SCALE THIS DRAWING.

SCALE: As indicated

DATE: 2021-08-25

PROJECT NO: 2020-0666-10

FILE:

DRAWN BY: NRC, CE

CHECKED BY: SL, NRC

COPYRIGHT © 2021 Walterfedy Inc.

SHEET NO: **A220**



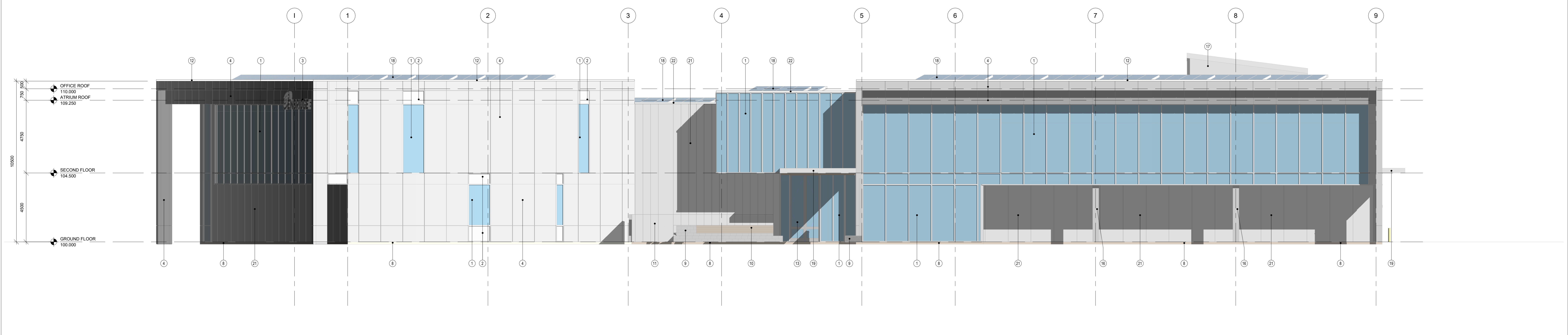

1 BUILDING ELEVATION - SOUTH  
 A301 Scale: 1:100

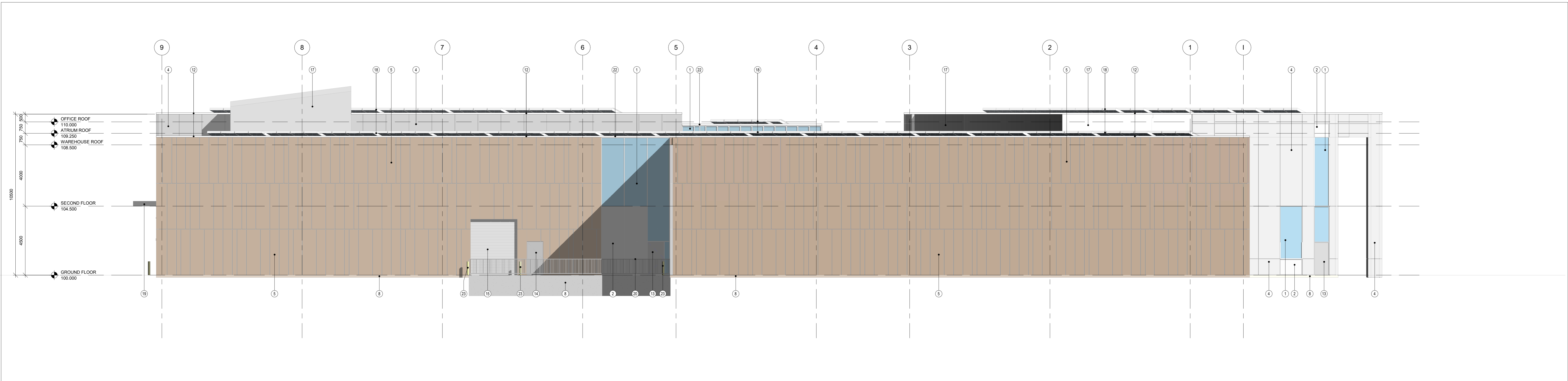

2 BUILDING ELEVATION - NORTH  
 A301 Scale: 1:100



3 BUILDING RENDER - ENTRANCE VIEW  
 A301 Scale: NOT TO SCALE



4 BUILDING RENDER - STAFF PARKING VIEW  
 A301 Scale: NOT TO SCALE

- ELEVATION LEGEND**
- ① FIBREGLASS CURTAIN WALL FRAME CW SEALED TRIPLE GLAZED UNIT - GLAZING TYPE 1
  - ② FIBREGLASS CURTAIN WALL FRAME CW SEALED DOUBLE GLAZED SPANDRALS
  - ③ ILLUMINATED BUILDING SIGNAGE ON METAL STANDOFFS
  - ④ PRE-FINISHED ALUMINUM COMPOSITE WALL PANEL COLOUR - LIGHT GREY (FIELD 1)
  - ⑤ PRE-FINISHED INSULATED METAL WALL PANEL COLOUR 1 - BRONZE (FIELD 2)
  - ⑥ PRE-FINISHED INSULATED METAL WALL PANEL COLOUR 2 - DARK BRONZE (ACCENT 1)
  - ⑦ PRE-FINISHED INSULATED METAL WALL PANEL COLOUR 3 - REFLECTIVE BRONZE (ACCENT 2)
  - ⑧ CONCRETE FOUNDATION RUBBED FINISH
  - ⑨ LIMESTONE MASONRY UNIT WALL
  - ⑩ WOOD LOOK ACCENT WALL PANEL
  - ⑪ GLASS PANEL WIND SCREEN
  - ⑫ PRE-FINISHED METAL CAP FLASHING CW DRIP EDGE, COLOUR TO MATCH WALL PANEL FIELD COLOUR
  - ⑬ ANODIZED ALUMINUM DOOR
  - ⑭ INSULATED HOLLOW METAL DOOR AND FRAME - HOT DIP GALVANIZED G90 PAINT FINISH
  - ⑮ PRE-FINISHED INSULATED METAL SECTIONAL OVERHEAD DOOR
  - ⑯ ALUMINUM COMPOSITE PANEL CLAD STEEL COLUMN
  - ⑰ PRE-FINISHED METAL SIDING PANEL COLOUR - GREY
  - ⑱ PHOTOVOLTAIC PANEL SOLAR ARRAY
  - ⑲ PRE-FINISHED ALUMINUM COMPOSITE PANEL CLAD CANOPY
  - ⑳ G90 GALVANIZED STEEL RAILING/GUARD
  - ㉑ FIBREGLASS CURTAIN WALL FRAME CW SEALED TRIPLE GLAZED UNIT SET IN SILICONE JOINTS - GLAZING TYPE 2
  - ㉒ PRE-FINISHED METAL CAP FLASHING CW DRIP EDGE, COLOUR TO MATCH CURTAIN WALL FRAME
  - ㉓ CONCRETE FILLED STEEL PIPE BOLLARD, COLOUR - YELLOW

THIS PLAN IS APPROVED BY THE CITY OF OTTAWA UNDER SECTION 41 OF THE PLANNING ACT THIS 28 DAY OF SEPTEMBER, 2022.

LILY XU, MCIP, RPP, MANAGER  
 DEVELOPMENT REVIEW SOUTH  
 PLANNING, INFRASTRUCTURE AND ECONOMIC  
 DEVELOPMENT DEPARTMENT, CITY OF OTTAWA

CLIENT  
**ENBRIDGE GAS**

PROJECT  
**OTTAWA OPERATIONS CENTRE**

2571 LANCASTER ROAD, OTTAWA, ON

TITLE  
**BUILDING ELEVATIONS**

**WALTERFEDY**  
 KITCHENER HAMILTON 800.665.1378 walterfedy.com

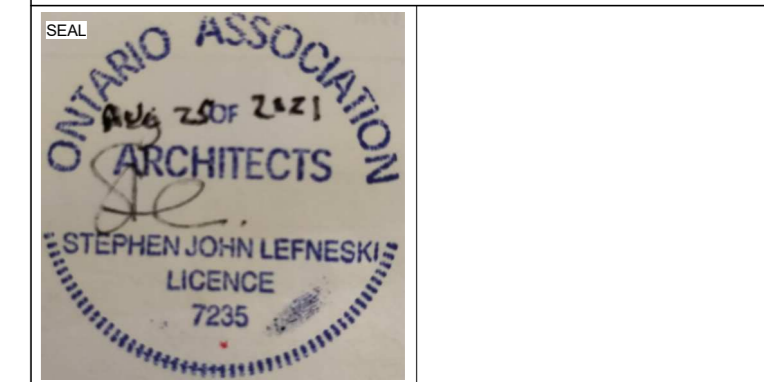

REPRODUCTION OR DISTRIBUTION FOR PURPOSES OTHER THAN AUTHORIZED BY WALTERFEDY CONTRACTORS SHALL BE VOID AND BE RESPONSIBLE FOR ALL DIMENSIONS AND CONDITIONS ON THE JOB AND REPORT ANY VARIATIONS FROM THE DIMENSIONS AND CONDITIONS SHOWN ON DRAWINGS TO WALTERFEDY. DO NOT SCALE THIS DRAWING.

SCALE: As Indicated SHEET NO:  
 DATE: 2021-08-25  
 PRODUCT NO: 2020-0666-10  
 FILE:  
 DRAWN BY: NRC, CE  
 CHECKED BY: SL, NRC

**A301**



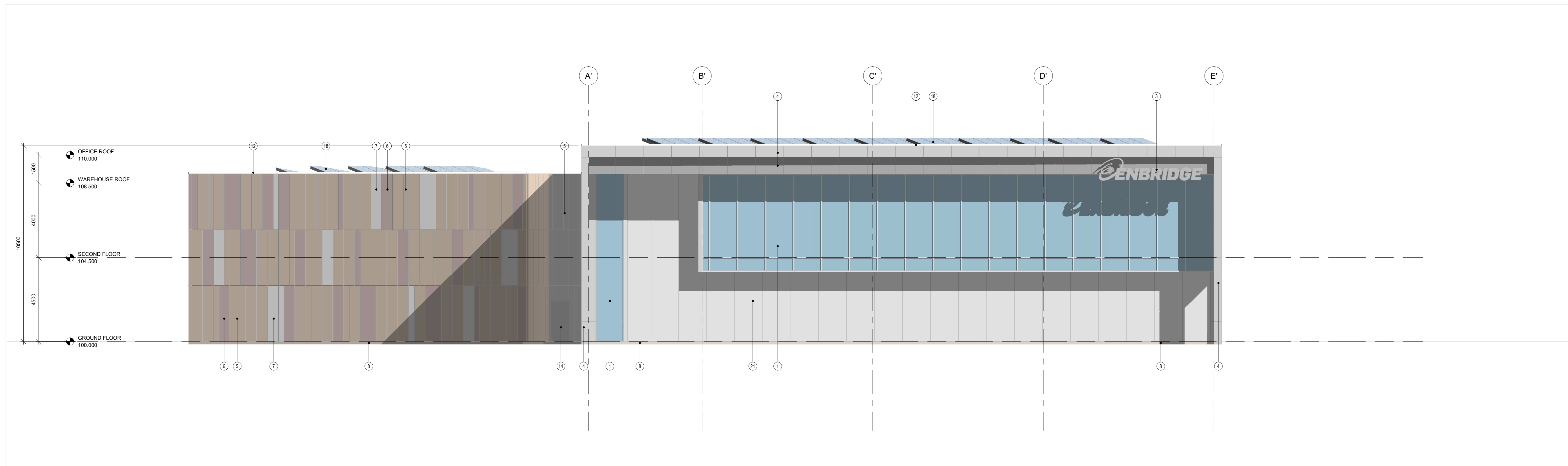

1 BUILDING ELEVATION - WEST  
A302 Scale: 1:100

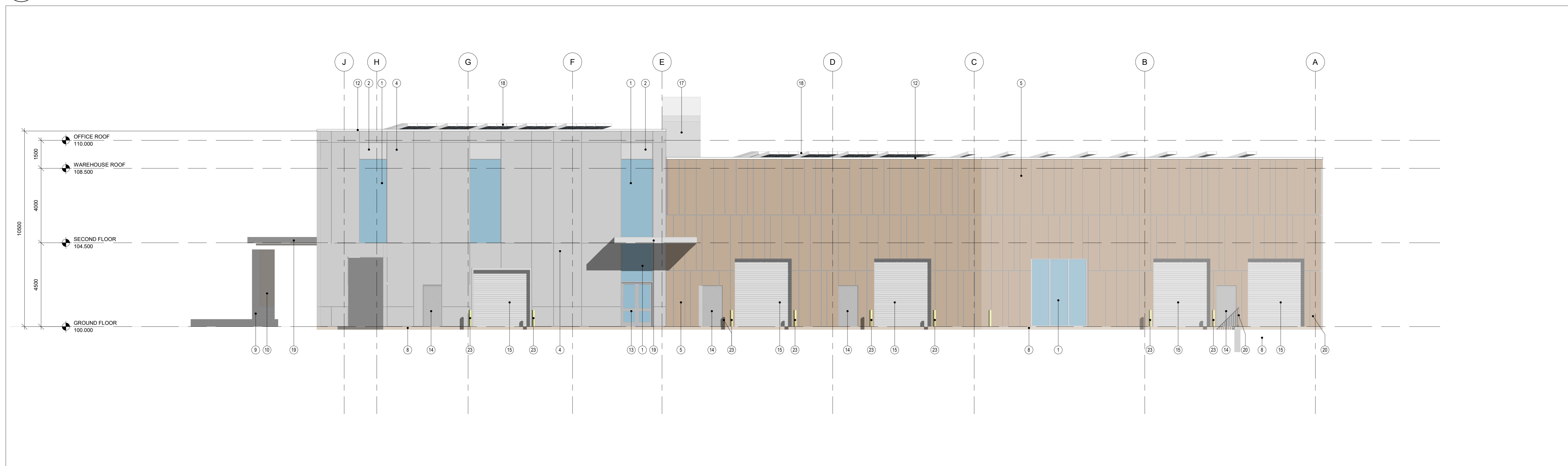

2 BUILDING ELEVATION - EAST  
A302 Scale: 1:100



3 BUILDING RENDER - STREET VIEW  
A302 Scale: NOT TO SCALE



4 BUILDING RENDER - STREET VIEW  
A302 Scale: NOT TO SCALE

ELEVATION LEGEND

- ① FIBREGLASS CURTAIN WALL FRAME CW SEALED TRIPLE GLAZED UNIT - GLAZING TYPE 1
- ② FIBREGLASS CURTAIN WALL FRAME CW SEALED DOUBLE GLAZED SPANDREL PANEL
- ③ ILLUMINATED BUILDING SIGNAGE ON METAL STANDOFFS
- ④ PRE-FINISHED ALUMINUM COMPOSITE WALL PANEL, COLOUR - LIGHT GREY (FIELD 1)
- ⑤ PRE-FINISHED INSULATED METAL WALL PANEL, COLOUR 1 - BRONZE (FIELD 2)
- ⑥ PRE-FINISHED INSULATED METAL WALL PANEL, COLOUR 2 - DARK BRONZE (ACCENT 1)
- ⑦ PRE-FINISHED INSULATED METAL WALL PANEL, COLOUR 3 - REFLECTIVE BRONZE (ACCENT 2)
- ⑧ CONCRETE FOUNDATION, RUBBED FINISH
- ⑨ LIMESTONE MASONRY UNIT WALL
- ⑩ WOOD LOOK ACCENT WALL PANEL
- ⑪ GLASS PANEL WIND SCREEN
- ⑫ PRE-FINISHED METAL CAP FLASHING CW DRIP EDGE, COLOUR TO MATCH WALL PANEL FIELD COLOUR
- ⑬ ANODIZED ALUMINUM DOOR
- ⑭ INSULATED HOLLOW METAL DOOR AND FRAME, HOT DIP GALVANIZED G90, PAINT FINISH
- ⑮ PRE-FINISHED INSULATED METAL SECTIONAL OVERHEAD DOOR
- ⑯ ALUMINUM COMPOSITE PANEL CLAD STEEL COLUMN
- ⑰ PRE-FINISHED METAL SIDING PANEL, COLOUR - GREY
- ⑱ PHOTOVOLTAIC PANEL SOLAR ARRAY
- ⑲ PRE-FINISHED ALUMINUM COMPOSITE PANEL CLAD CANOPY
- ⑳ GRG GALVANIZED STEEL RAILING/GUARD
- ㉑ FIBREGLASS CURTAIN WALL FRAME CW SEALED TRIPLE GLAZED UNIT SET IN SILICONE JOINTS - GLAZING TYPE 2
- ㉒ PRE-FINISHED METAL CAP FLASHING CW DRIP EDGE, COLOUR TO MATCH CURTAIN WALL FRAME
- ㉓ CONCRETE FILED STEEL PIPE BOLLARD, COLOUR - YELLOW



CLIENT LOGO

KEY PLAN

No.	ISSUANCE	DATE
1	ISSUED FOR SITE PLAN CONTROL	2021-08-25

CLIENT

ENBRIDGE GAS

500 CONSUMERS ROAD, NORTH YORK, ON

PROJECT

OTTAWA OPERATIONS CENTRE

2571 LANCASTER ROAD, OTTAWA, ON

TITLE

BUILDING ELEVATIONS

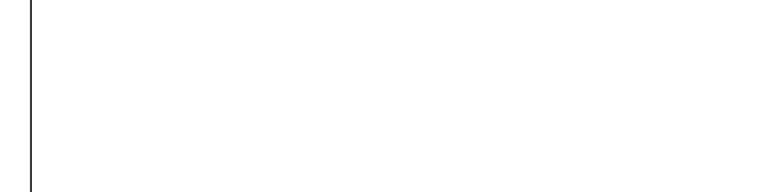

KITCHENER HAMILTON 800.665.1378 walterfedy.com

PROFESSIONAL ASSOCIATION

ARCHITECTS

STEPHEN JOHN LEFNEKIS

LICENCE 7235

REPRODUCTION OR DISTRIBUTION FOR PURPOSES OTHER THAN AUTHORIZED BY WALTERFEDY IS PROHIBITED. CONTRACTORS SHALL VERIFY AND BE RESPONSIBLE FOR ALL DIMENSIONS AND CONDITIONS ON THE JOB AND REPORT ANY VARIATIONS FROM THE DIMENSIONS AND CONDITIONS SHOWN ON DRAWINGS TO WALTERFEDY. DO NOT SCALE THIS DRAWING.

COPYRIGHT © 2021 Walterfedy Inc.

SCALE: As indicated SHEET NO:

DATE: 2021-08-25

PROJECT NO: 2020-0666-10

FILE:

DRAWN BY: NRC, CE

CHECKED BY: SL, NRC

THIS PLAN IS APPROVED BY THE CITY OF OTTAWA UNDER SECTION 41 OF THE PLANNING ACT THIS 28 DAY OF SEPTEMBER, 2022.

LILY XU, MCIIP, RPP, MANAGER  
DEVELOPMENT REVIEW SOUTH  
PLANNING, INFRASTRUCTURE AND ECONOMIC  
DEVELOPMENT DEPARTMENT, CITY OF OTTAWA

A302