

SERVICING & STORMWATER MANAGEMENT REPORT 5-STOREY RESIDENTIAL BUILDING – 949 NORTH RIVER ROAD



Project No.: CCO-21-2796

City File No.: D07-12-21-0150

Prepared for:

Gemstone Corporation
252 Argyle Avenue
Ottawa, ON K2P 1B9

Prepared by:

McIntosh Perry Consulting Engineers Ltd.
115 Walgreen Road
Carp, ON K0A 1L0

REV1: 2022-03-04

McINTOSH PERRY

TABLE OF CONTENTS

1.0	PROJECT OVERVIEW	1
1.1	Purpose	1
1.2	Site Description	1
1.3	Proposed Development and Statistics	2
1.4	Existing Conditions and Infrastructure	2
1.5	Approvals	3
2.0	BACKGROUND STUDIES, STANDARDS AND REFERENCES	4
2.1	Background Reports / Reference Information	4
2.2	Applicable Guidelines and Standards	4
3.0	PRE-CONSULTATION SUMMARY	5
4.0	WATERMAIN	6
4.1	Existing Watermain	6
4.2	Proposed Watermain	6
5.0	SANITARY DESIGN	8
5.1	Existing Sanitary Sewer	8
5.2	Proposed Sanitary Sewer	8
6.0	STORM SEWER DESIGN	10
6.1	Existing Storm Sewers	10
6.2	Proposed Storm Sewers	10
7.0	PROPOSED STORM WATER MANAGEMENT	11
7.1	Design Criteria and Methodology	11
7.2	Runoff Calculations	11
7.3	Pre-Development Drainage	12
7.4	Post-Development Drainage	12
7.5	Quantity Control	13
8.0	EROSION AND SEDIMENT CONTROL	15
8.1	Temporary Measures	15
8.2	Permanent Measures	15

9.0	SUMMARY.....	17
10.0	RECOMMENDATION.....	18
11.0	STATEMENT OF LIMITATIONS.....	19

LIST OF TABLES

Table 1: Water Supply Design Criteria and Water Demands	6
Table 2: Boundary Conditions Results	7
Table 3: Fire Protection Confirmation.....	7
Table 4: Wastewater Design Criteria	8
Table 5: Summary of Estimated Wastewater Flow.....	9
Table 6: Pre-Development Runoff Summary.....	12
Table 7: Post-Development Runoff Summary	12
Table 8: Post-Development Restricted Runoff Summary	13

APPENDICES

Appendix A: Site Location Plan

Appendix B: City of Ottawa Pre-Consultation Notes

Appendix C: Watermain Calculations

Appendix D: Sanitary Calculations

Appendix E: Pre-Development Drainage Plan

Appendix F: Post-Development Drainage Plan

Appendix G: Stormwater Management Calculations

Appendix H: City of Ottawa Design Checklist

1.0 PROJECT OVERVIEW

1.1 Purpose

McIntosh Perry (MP) has been retained by Gemstone Corporation to prepare this Servicing and Stormwater Management Report in support of the Site Plan Control application for the proposed 5-Storey Residential Building, located at 949 North River Road within the City of Ottawa.

The main purpose of this report is to present a servicing and stormwater management design for the development in accordance with the recommendations and guidelines provided by the City of Ottawa (City), the Rideau Valley Conservation Authority (RVCA), and the Ministry of the Environment, Conservation and Parks (MECP). This report will address the water, sanitary and storm sewer servicing for the development, ensuring that existing infrastructure available will adequately service the proposed development.

This report should be read in conjunction with the following drawing:

- 000-21-2796, C101 - Site Servicing, Combined Grading and Drainage Plan, Sediment and Erosion Control Plan.
- 000-21-2796, PRE – Pre-Development Drainage Plan
- 000-21-2796, Post – Post-Development Drainage Plan

1.2 Site Description

The subject property, herein referred to as the site, is located at 949 North River Road within the Rideau-Rockcliffe Ward. The legal description of the site is Lot 8, Concession Junction Gore, Geographic Township of Gloucester, City of Ottawa. The site covers approximately 0.17 ha and is located between North River Road and Ontario Street as shown by Figure 1 below. The site is zoned for Residential Use (R4UC). Additional details are included on the Site Location Plan included in Appendix 'A'.



Figure 1: Site Map

1.3 Proposed Development and Statistics

The proposed development consists of a 5-storey, residential building. The Site Plan proposes to have 46 residential units, with 443 m² of amenity space. Underground parking with an access ramp will be provided internal to the site. There will be one site access for the development from Ontario Street. Visitor surface parking will be located at the north of the site.

1.4 Existing Conditions and Infrastructure

The existing site is located within the City of Ottawa's Rideau River Sub-Watershed and is currently developed as a multi-unit two-storey residential building. The site is sloped at approximal 0.7 % towards North River Road and 0.5% towards Ontario Street as shown by drawing PRE located within Appendix E. The existing site is assumed to have water and sanitary services. It is assumed that storm runoff from the existing site flows to the City's right-of-ways in North River Road and Ontario Street.

Sewer and watermain mapping collected from the City of Ottawa indicate that the following services exist across the property frontages within the adjacent municipal right-of-ways:

- ◆ Ontario Street
 - 203 mm dia. PVC Watermain
 - 225 mm dia. PVC. Sanitary Sewer tributary to the Rideau River Collector Twin and ultimately the Interceptor Sewer
 - 600 mm dia. concrete Storm Sewer, tributary to the Rideau River

- ◆ North River Road
 - 203 mm dia. PVC Watermain
 - 1950 mm dia. concrete Sanitary Sewer tributary to the Rideau River Collector Twin and ultimately the Interceptor Sewer
 - 900 mm dia. Concrete Storm Sewer, tributary to the Rideau River

1.5 Approvals

The contemplated development is subject to the City of Ottawa site plan control approval process. Site plan control requires the City to review, provide concurrence and approve the engineering design package. Permits to construct can be requested once the City has issued a site plan agreement.

An Environmental Compliance Approval (ECA) through the Ministry of Environment, Conservation and Parks (MECP) is not anticipated to be required for the contemplated development as the stormwater management system meets the exemption requirements under O.Reg 525/90. It is a single parcel; stormwater is not proposed to outlet to a combined sewer and is not zoned or proposed to be an industrial use.

2.0 BACKGROUND STUDIES, STANDARDS AND REFERENCES

2.1 Background Reports / Reference Information

As-built drawings of existing services, provided by the City of Ottawa Information centre, within the vicinity of the proposed site were reviewed in order to identify infrastructure available to service the proposed development.

A topographic survey (2139123) of the site was completed by Farley, Smith & Denis Surveying Ltd. dated March 23, 2021.

The Site Plan, A105 was prepared by Figurr Architects Collective dated February 16, 2022 (Site Plan).

2.2 Applicable Guidelines and Standards

City of Ottawa:

- ◆ Ottawa Sewer Design Guidelines, City of Ottawa, SDG002, October 2012. (Ottawa Sewer Guidelines)
 - Technical Bulletin ISTB-2014-01 City of Ottawa, February 2014. (ISTB-2014-01)
 - Technical Bulletin ISTB-2018-01 City of Ottawa, January 2018. (ISTB-2018-01)
 - Technical Bulletin ISTB-2018-03 City of Ottawa, March 2018. (ISTB-2018-03)
 - Technical Bulletin ISTB-2019-01 City of Ottawa, January 2019. (ISTB-2019-01)
 - Technical Bulletin ISTB-2019-02 City of Ottawa, February 2019. (ISTB-2019-02)
- ◆ Ottawa Design Guidelines – Water Distribution City of Ottawa, July 2010. (Ottawa Water Guidelines)
 - Technical Bulletin ISD-2010-2 City of Ottawa, December 15, 2010. (ISD-2010-2)
 - Technical Bulletin ISDTB-2014-02 City of Ottawa, May, 2014. (ISDTB-2014-02)
 - Technical Bulletin ISTB-2018-03 City of Ottawa, March 2018. (ISTB-2018-03)

Ministry of Environment, Conservation and Parks:

- ◆ Stormwater Planning and Design Manual, Ministry of the Environment, March 2003. (MECP Stormwater Design Manual)
- ◆ Design Guidelines for Sewage Works, Ministry of the Environment, 2008. (MECP Sewer Design Guidelines)

3.0 PRE-CONSULTATION SUMMARY

A pre-consultation meeting was conducted on October 9, 2020 regarding the proposed site. Specific design parameters to be incorporated within this design include the following.

- ◆ Pre-development and post-development flows shall be calculated using a time of concentration (T_c) with a minimum T_c of 10 minutes.
- ◆ Coefficient (C) of runoff determined as per existing conditions but in no case more than 0.5. Any storm events greater than 2 year, up to 100 year, and including 100-year storm event must be detained on site.
- ◆ Roof drains are to be connected downstream of any incorporated ICD within the storm water management system.
- ◆ RCVA to provide quality control requirements.

The notes from the City of Ottawa pre-consultation can be found in Appendix B.

4.0 WATERMAIN

4.1 Existing Watermain

There is an existing 203 mm diameter PVC watermain within Ontario Street and a 203 mm diameter watermain within North River Road available to service the development.

4.2 Proposed Watermain

A 150 mm diameter PVC water lateral is proposed to service the site complete with a valve located 0.3 m from the proposed connection. It will be connected to the existing 200 mm diameter watermain within Ontario Street. The lateral is designed to have a minimum cover of 2.4m.

The Fire Underwriters Survey 1999 (FUS) method was utilized to estimate the required fire flow for the site. Fire flow requirements were calculated per City of Ottawa Technical Bulletin ISTB-2018-03. The following parameters were coordinated with the architect:

- ◆ Type of construction – Non-Combustible Construction
- ◆ Occupancy type – Limited Combustibility
- ◆ and Sprinkler Protection – Fully Supervised Sprinkler

The results of the calculations yielded a required fire flow of 12,000 L/min (200 L/s). The detailed calculations for the FUS can be found in Appendix C.

The water demands for the proposed building have been calculated to adhere to Ottawa Water Guidelines and can be found in Appendix C. The results have been summarized below:

Table 1: Water Supply Design Criteria and Water Demands

Site Area	0.17 ha
Amenity Space	443 m ²
Residential	280 L/day/person
Commercial/ Amenity	28,000 L/gross ha/d
Average Day Demand (L/s)	0.26
Maximum Daily Demand (L/s)	1.35
Peak Hourly Demand (L/s)	2.03
FUS Fire Flow Requirement (L/s)	200.00

The City provided the estimated water pressures at both for the average day scenario, peak hour scenario, and the max day plus fire flow scenario for the demands indicated by the correspondence in Appendix C. Note that minor updates to the water demands have been made since the original

boundary condition request. It is not anticipated to have a significant impact on the previously provided pressures.

The resulting pressures for the boundary conditions results are shown in Table 2, below.

Table 2: Boundary Conditions Results

Scenario	Proposed Demands (L/S)	Connection 1 HGL (m H ₂ O)* / kPa
Average Day Demand	0.26	60.10 / 589.4
Maximum Daily + Fire Flow Demand	268.35	30.8 / 302.0**
Peak Hourly Demand	2.03	51.1 / 501.1
* Adjusted for an estimated ground elevation of 58.42 above the connection point for both connections		
** Based on a fire flow demand of 16,000 L/min (267L/s)		

The normal operating pressure range is anticipated to be 5011 kPa to 589.4 kPa and will not be less than 275 kPa (40 psi). The proposed watermains will meet the minimum required 20 psi (140 kPa) from the Ottawa Water Guidelines at the ground level under maximum day demand and fire flow conditions.

To confirm the adequacy of fire flow to protect the proposed development, public and private fire hydrants within 150 m of the proposed building were accounted for per ISTB 2018-03 Appendix I, Table 3. as demonstrated below.

Table 3: Fire Protection Confirmation

Building	Fire Flow Demand (L/min.)	Fire Hydrant(s) within 75m	Fire Hydrant(s) within 150m	Combined Fire Flow (L/min.)
949 North River Road	12,000	2	1	15,200

5.0 SANITARY DESIGN

5.1 Existing Sanitary Sewer

There is an existing 225 mm diameter concrete sanitary collection sewer tributary to the Rideau River Collector Twin within Ontario Street that is available to service the development.

5.2 Proposed Sanitary Sewer

The development proposes to be serviced by a new 200 mm diameter gravity sanitary service which will be connected to the existing 225 mm diameter sanitary sewer within Ontario Street.

Table 4: Sanitary Design Criteria

Design Parameter	Value
Average Residential 1 Bedroom Apartment	1.4 persons/unit
Average Residential 2 Bedroom Apartment	2.1 persons/unit
Average Daily Demand	280 L/day/person
Commercial / Amenity Space	2500 L/(1000m ² / day)

Table 5: Summary of Estimated Sanitary Flow

Design Parameter	Total Flow (L/S)
Total Estimated Average Dry Weather Flow	0.27
Total Estimated Peak Dry Weather Flow	0.92
Total Estimated Peak Wet Weather Flow	0.97

The estimated sanitary flow based on the Site Plan results in a peak wet weather flow of 0.97L/s. The proposed 200 mm diameter gravity sanitary service will be installed with a minimum full flow target velocity (cleansing velocity) of 0.6 m/s and a full flow velocity of not more than 3.0 m/s. Design parameters for the site include an infiltration rate of 0.33 L/s/ha. The proposed service for the site will be connected to the existing 225 mm diameter sanitary sewer within Ontario Street.

6.0 STORM SEWER DESIGN

6.1 Existing Storm Sewers

It was determined that runoff from the existing site is directed to the existing 600 mm sewer within Ontario Street. Stormwater runoff from the existing site is tributary to the Rideau River within the Ottawa Central sub-watershed.

6.2 Proposed Storm Sewers

A new 250 mm diameter storm service will service the proposed building extending from the existing 600 mm diameter storm sewer within Ontario Street.

Runoff collected on the roof of the proposed building will be stored and controlled internally using four roof drains. Roof drains will be used to limit the flow from the roof to the specified allowable release rate. For calculation purposes a Watts Accutrol roof drain was used estimate a reasonable roof flow. Other products may be specified at detailed building design so long as release rates and storage volumes are respected.

Runoff from the proposed surface parking lot area will be directed to a swale where it will be treated for quality, stored, and controlled. Storm flows from this will be controlled by an inlet control device (ICD) to limit the flow to the specified allowable release rate. The controlled flow will be directed to the 600 mm storm sewer within Ontario Street via a 250 mm storm service.

See COO-21-2796 - POST and Storm Sewer Design Sheet in Appendix 'F' of this report for more details. The Stormwater Management design for the subject property will be outlined in Section 7.0.

7.0 PROPOSED STORMWATER MANAGEMENT

7.1 Design Criteria and Methodology

Stormwater management for the proposed site will be maintained through two methods. The first will store and control runoff collected on the roof of the proposed building. It is estimated that four Watts Accutrol Weirs will be used to control the release rate of the stormwater. The flow will be directed to the existing 600 mm storm sewer located within Ontario Street.

The second method involves using positive drainage away from the proposed building and parking lot to direct the flow towards a 1219x1219 mm FT404 Filterra Bioscape Vault Basin which will provide quality control for the storm water runoff. Treated flow from the Bioscape Vault Basin will be directed to a swale (as per City of Ottawa Standard S29) which will provide storage in the 250 mm diameter pipe and the void space between the 25 mm clear stone in the trench. The swale will direct the flow to a catch basin that is installed with an ICD to control the release rate into the City's right of way within Ontario Street.

In summary, the following design criteria have been employed in developing the stormwater management design for the site as directed by the RVCA and City:

Quality Control

- Based on the proximity of the site to the Rideau River, it was anticipated that enhanced quality control measures are required.

Quantity Control

- Post-development 5 & 100-year flow is to be restricted to match the 5-year pre-development flow with a maximum C value of 0.50.

7.2 Runoff Calculations

Runoff calculations presented in this report are derived using the Rational Method, given as:

$$Q = 2.78 CIA \text{ (L/s)}$$

Where	C	= Runoff coefficient
	I	= Rainfall intensity in mm/hr (City of Ottawa IDF curves)
	A	= Drainage area in hectares

It is recognized that the Rational Method tends to overestimate runoff rates. As a result, the conservative calculation of runoff ensures that any SWM facility sized using this method is expected to function as intended.

The following coefficients were used to develop an average C for each area:

Roofs/ Concrete/ Asphalt	0.90
Gravel	0.60
Undeveloped and Grass	0.20

As per the Ottawa Sewer Guidelines, the 5-year balanced ‘C’ value must be increased by 25% for a 100-year storm event to a maximum of 1.0.

As per the pre-consultation meeting with the City of Ottawa the time of concentration (Tc) used for pre-development shall be calculated and no less than 10 minutes and post-development flows shall be calculated and no less than 10 minutes.

7.3 Pre-Development Drainage

The existing site drainage limits are demonstrated on the Pre-Development Drainage Area Plan. A summary of the Pre-Development runoff calculations can be found in Table 6, below.

Table 6: Pre-Development Runoff Summary

Drainage Area	Area (ha)	Runoff Coefficient (5-Year)	Runoff Coefficient (100-Year)	5-year Peak Flow (L/s)	100-year Peak Flow (L/s)
A1	0.168	0.71	0.79	34.25	65.86
Total	0.168			34.25	65.86

See COO-21-2796 - PRE in Appendix E and Appendix G for calculations.

7.4 Post-Development Drainage

The proposed site drainage limits are demonstrated on the Post-Development Drainage Area Plan. See COO-21-2796 - POST in Appendix F of this report for more details. A summary of the Post-Development runoff calculations can be found in Table 7, below.

Table 7: Post-Development Runoff Summary

Drainage Area	Area (ha)	Runoff Coefficient (5-Year)	Runoff Coefficient (100-Year)	5-year Peak Flow (L/s)	100-year Peak Flow (L/s)
B1	0.084	0.90	1.00	21.89	41.69
B2	0.032	0.73	0.82	6.75	12.96
B3	0.045	0.52	0.59	6.76	13.22
B4	0.007	0.20	0.25	0.39	0.84
Total	0.168			35.80	68.71

See Appendix G for calculations. Runoff for area B1 will be restricted using roof drains. The Accutrol Weirs will restrict the 5 through 100-year flows creating the need for roof storage. Runoff for area B2 will be restricted before releasing to the existing storm system within Ontario Street. The flow will be controlled within a catch basin installed with an ICD. The flow from Area B3 will be directed to the City’s right of ways without restriction. Runoff from area B4 will be collected by area drains and directed to the building’s internal mechanical system without attenuation.

7.5 Quantity Control

After discussing the stormwater management criteria for the site with City staff, the total post-development runoff for this site has been restricted to match the 5-year pre-development flow rate with a combined C value of 0.50. The site is required to restrict flow to a maximum release rate of 24.27 L/s for events up to and including a 100-year storm event. See Appendix G for calculations and Appendix G for pre-consultation notes.

Table 8: Post-Development Restricted Runoff Summary

Drainage Area	Post Development Unrestricted Flow (L/s)		Post Development Restricted Flow (L/s)	
	5-Year	100-Year	5-Year	100-Year
B1 (Restricted)	21.89	41.69	1.76	3.04
B2 (Restricted)	6.75	12.96	1.80	3.00
B3 (Unrestricted)	6.76	13.22	6.76	13.22
B4 (Unrestricted)	0.39	0.84	0.39	0.84
Total	35.80	68.71	10.72	20.10

Runoff for area B1 will be stored on the roof of the proposed building and restricted internally using an Accutrol Weir to 1.76 L/s and 3.04 L/s for the 5 and 100-year storm events, respectively. Area B1 will also provide up to 36.05 m³ of storage. The runoff from Area B2 will be restricted through an Ipex Tempest LMF 65 ICD or approved equivalent that will control the flows for the 5 & 100-year storm events to 1.80 L/s and 3.00 L/s, respectively. The proposed swale that directs flow to the ICD will provide up to 11.56 m³ of storage. See Appendix G for calculations.

7.6 Quality Control

It is anticipated that enhanced quality control measures are required based on the proposed above ground parking and site’s proximity to the Rideau River. This will be provided by directing flow from the parking lot to a Filterra FT040 Bioscape Vault Basin. The drainage area being directed into to the

Vault Basin is approximately 0.034 ha. The 1219 x 1219 mm Bioscape Vault Basin is designed to treat a drainage area of 0.035 ha and will provide a TSS removal of 85%. See Appendix G for a specification sheet.

8.0 EROSION AND SEDIMENT CONTROL

8.1 Temporary Measures

Before construction begins, temporary silt fence, straw bale or rock flow check dams will be installed at all-natural runoff outlets from the property. It is crucial that these controls be maintained throughout construction and inspection of sediment and erosion control will be facilitated by the Contractor or Contract Administration staff throughout the construction period.

Silt fences will be installed where shown on the final engineering plans, specifically along the downstream property limits. The Contractor, at their discretion or at the instruction of the City, Conservation Authority or the Contract Administrator shall increase the quantity of sediment and erosion controls on-site to ensure that the site is operating as intended and no additional sediment finds its way off site. The rock flow, straw bale & silt fence check dams and barriers shall be inspected weekly and after rainfall events. Care shall be taken to properly remove sediment from the fences and check dams as required. Fibre roll barriers are to be installed at all existing curb inlet catch basins and filter fabric is to be placed under the grates of all existing catch basins and manholes along the frontage of the site and any new structures immediately upon installation. The measures for the existing/proposed structures is to be removed only after all areas have been paved. Care shall be taken at the removal stage to ensure that any silt that has accumulated is properly handled and disposed of. Removal of silt fences without prior removal of the sediments shall not be permitted.

Although not anticipated, work through winter months shall be closely monitored for erosion along sloped areas. Should erosion be noted, the Contractor shall be alerted and shall take all necessary steps to rectify the situation. Should the Contractor's efforts fail at remediating the eroded areas, the Contractor shall contact the City and/or Conservation Authority to review the site conditions and determine the appropriate course of action. As the ground begins to thaw, the Contractor shall place silt fencing at all required locations as soon as ground conditions warrant. Please see the Site Grading, Drainage and Sediment & Erosion Control Plan for additional details regarding the temporary measures to be installed and their appropriate OPSD references.

8.2 Permanent Measures

Rip-rap will be placed at all locations that have the potential for concentrated flow. It is crucial that the Contractor ensure that the geotextile is keyed in properly to ensure runoff does not undermine the rip rapped area. Additional rip rap is to be placed at erosion prone locations as identified by the Contractor / Contract Administrator / City or Conservation Authority.

It is expected that the Contractor will promptly ensure that all disturbed areas receive topsoil and seed/sod and that grass be established as soon as possible. Any areas of excess fill shall be removed or levelled as soon as possible and must be located a sufficient distance from any watercourse to ensure that no sediment is washed out into the watercourse. As the vegetation growth within the site provides a key component to the control of sediment for the site, it must be properly maintained

once established. Once the construction is complete, it will be up to the landowner to maintain the vegetation and ensure that the vegetation is not overgrown or impeded by foreign objects.

9.0 SUMMARY

- A new 5 storey residential building is proposed to be constructed along the west property line at 949 North River Road.
- A 150 mm diameter water service is proposed to service the site, connecting to the watermain within Ontario Street.
- A 200 mm sanitary service is proposed to service the site, connecting to the sanitary sewer within Ontario Street.
- A 250 mm diameter storm service is proposed to service the site, connecting to the storm sewer within Ontario Street.
- Storage for the 5-through 100-year storm events will be provided via the roof of the proposed building and in a swale. The post-development flows for the site will be controlled to 10.72 L/s and 20.10 L/s for the 5 and 100-year storms, respectively. Up to 49.35 m³ of storage will be provided on site.
- A quality control of 85% TSS removal will be provided by a Filterra FT040 Bioscape Vault Basin.

10.0 RECOMMENDATION

Based on the information presented in this report, we recommend that City of Ottawa approve this Servicing and Stormwater Management Report in support of the proposed 949 North River Road Development.

This report is respectfully being submitted for approval.

Regards,

McIntosh Perry Consulting Engineers Ltd.



Robert D. Freel, P.Eng.
Senior Project Manager
T: 613.714.6174
E: r.freel@mcintoshperry.com

Ryan R. Robineau, EIT
Civil Engineering Technologist – Land
Development
T: 613.714.6611
E: r.robineau@mcintoshperry.com

u:\ottawa\01 project - proposals\2021 jobs\cco\cco-21-2796 gemstone - 949 n river road\03 - servicing\report\cco-21-2796_servicing
report.docx

11.0 STATEMENT OF LIMITATIONS

This report was produced for the exclusive use of Gemstone Corporation. The purpose of the report is to assess the existing stormwater management system and provide recommendations and designs for the post-construction scenario that are in compliance with the guidelines and standards from the Ministry of the Environment, Conservation and Parks, City of Ottawa and local approval agencies. McIntosh Perry reviewed the site information and background documents listed in Section 2.0 of this report. While the previous data was reviewed by McIntosh Perry and site visits were performed, no field verification/ measures of any information were conducted.

Any use of this review by a third party, or any reliance on decisions made based on it, without a reliance report is the responsibility of such third parties. McIntosh Perry accepts no responsibility for damages, if any, suffered by any third party as a result of decisions or actions made based on this review.

The findings, conclusions and/or recommendations of this report are only valid as of the date of this report. No assurance is made regarding any changes in conditions subsequent to this date. If additional information is discovered or becomes available at a future date, McIntosh Perry should be requested to re-evaluate the conclusions presented in this report, and provide amendments, if required.

**APPENDIX A
KEY PLAN**



LEGEND

- Site Location
- Local Road
- Major Road
- Railroad
- Watercourse
- Waterbody
- Wooded Area

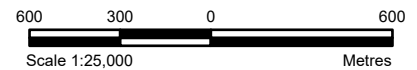

REFERENCE

GIS data provided by the Ontario Ministry of Natural Resources and Forestry, 2021.

CLIENT:		GEMSTONE DEVELOPMENTS	
PROJECT:		5-STOREY RESIDENTIAL BUILDING 949 NORTH RIVER ROAD, OTTAWA, ON	
TITLE:		SITE LOCATION	
PROJECT NO: CCO-21-2796		FIGURE:	
Date	Jul., 13, 2021	1	
GIS	EU		
Checked By	RR		

McINTOSH PERRY
 115 Walgreen Road, RR3, Carp, ON K0A1L0
 Tel: 613-836-2184 Fax: 613-836-3742
 www.mcintoshperry.com

**APPENDIX B
BACKGROUND DOCUMENTS**

PART OF LOT 8
CONCESSION JUNCTION GORE
GEOGRAPHIC TOWNSHIP OF GLOUCESTER
CITY OF OTTAWA
FARLEY, SMITH & DENIS SURVEYING LTD. 2021



Metric Note
Distances and coordinates on this plan are in metres and can be converted to feet by dividing by 0.3048.

Distance Note
Distances shown on this plan are ground distances and can be converted to grid distances by multiplying by the combined scale factor of 0.99995.

Bearing Note
Bearings hereon are grid bearings derived from the Can-Net Real Time Network and are referred to the Central Meridian of MTM Zone 9 (76°30' West Longitude) Nad-83 (Original).

For bearing comparisons, a rotation of 0°28'30" counter-clockwise was applied to bearings on P1, P2, P3 & P6.

Elevation Notes
1. Elevations shown are geodetic and are referred to Geodetic Datum CGVD-1928 -1978 (FSD File No. 01-17)
2. It is the responsibility of the user of this information to verify that the job benchmark has not been altered or disturbed and that its relative elevation and description agrees with the information shown on this drawing.

Utility Notes
1. This drawing cannot be accepted as acknowledging all of the utilities and it will be the responsibility of the user to contact the respective utility authorities for confirmation.
2. Only visible surface utilities were located.
3. Underground utility data compiled from City of Ottawa utility sheet reference: E-16-08, E-16-15, 13904 and 036-2.
4. Sanitary and storm sewer grades and inverts were derived/compiled from: Field measurement, City of Ottawa
5. A field location of underground plant by the pertinent utility authority is mandatory before any work involving breaking ground, probing, excavating etc.

Notes & Legend

Denotes	Notes
□	Survey Monument Planted
■	Survey Monument Found
SIB	Standard Iron Bar
SSIB	Short Standard Iron Bar
IB	Iron Bar
(Wit)	Witness
Meas	Measured
(P1)	Plan by (857) dated November 6, 1985 (Ref. No. 15-8 (I.G. GR)
(P2)	Plan 4R-8449
(P3)	Plan 5R-12500
(P4)	Plan 4R-22440
(P5)	Plan by (1287) dated May 28, 1991 (Job No. 37-91)
(P6)	CARLETON CONDOMINIUM PLAN 495
○ MH-ST	Maintenance Hole (Storm)
○ MH-S	Maintenance Hole (Sanitary)
○ MH-H	Maintenance Hole (Hydro)
ST	Underground Storm Sewer
S	Underground Sanitary Sewer
W	Underground Water
P	Underground Power
G	Underground Gas
OW	Overhead Wires
B	Underground Bell
U	Utility Pole
AN	Anchor
CB	Catch Basin
PH	Fire Hydrant
GM	Gas Meter
○	Deciduous Tree - The Symbol shown denotes location and trunk diameter only. Size of its root system/overhead canopy may be smaller/larger than the symbol size depicted on this plan.
★	Coniferous Tree - The Symbol shown denotes location and trunk diameter only. Size of its root system/overhead canopy may be smaller/larger than the symbol size depicted on this plan.
△ S	Sign
AC	Air Conditioner
CLF	Chain Link Fence
BF	Board Fence
CRW	Concrete Retaining Wall
TRW	Timber Retaining Wall
Inv.	Invert
T/G	Top of Grate
EI	Elevation
U/Eave	Underside of Eave
Topfdn	Top of Foundation
C/L	Centreline
+65.00	Location of Elevations
+65.00	Top of Concrete Curb Elevation

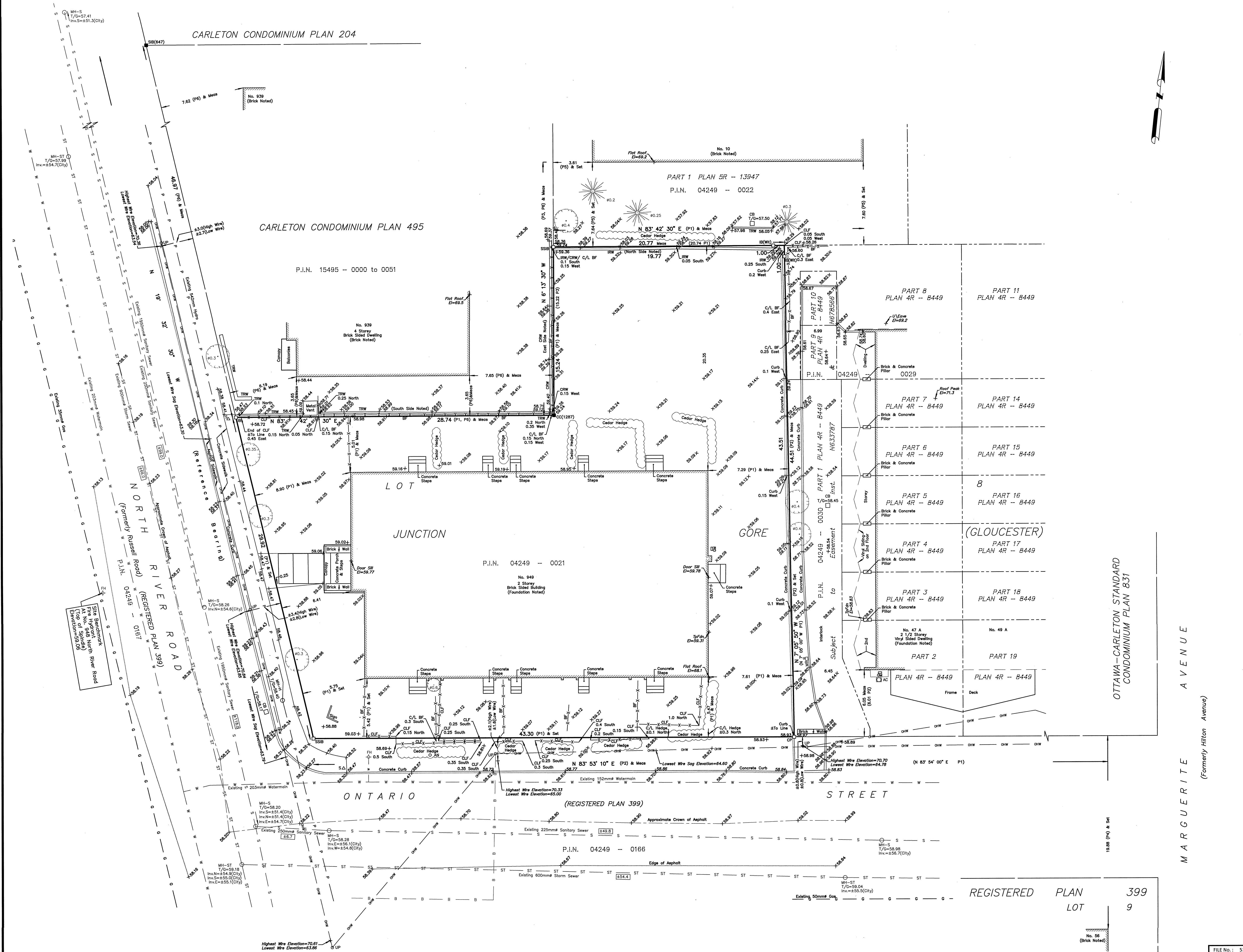

THIS PLAN IS NOT VALID UNLESS IT IS AN EMBOSSED ORIGINAL COPY ISSUED BY THE SURVEYOR. In accordance with Regulation 1026, Section 29 (3).

TOPOGRAPHIC DATA WAS COLLECTED UNDER WINTER CONDITIONS. SNOW COVER AND ICE PRECLUDE DETERMINING LOCATION AND ELEVATION OF SOME TOPOGRAPHICAL DATA THAT IS OTHERWISE VISIBLE.

WARNING NO PERSON MAY COPY, REPRODUCE, DISTRIBUTE OR ALTER THIS PLAN IN WHOLE OR IN PART WITHOUT THE WRITTEN PERMISSION OF FARLEY, SMITH & DENIS SURVEYING LTD. © FARLEY, SMITH & DENIS SURVEYING LTD., 2021.

Surveyor's Certificate
I certify that:
1. This survey and plan are correct and in accordance with the Surveys Act, the Surveyors Act and the Regulations made under them.
2. The survey was completed on the 11th day of March, 2021.

March 23/2021
Emad Alrefaai
Ontario Land Surveyor

FARLEY, SMITH & DENIS SURVEYING LTD.
ONTARIO LAND SURVEYORS
CANADA LAND SURVEYORS
190 COLONNADE ROAD, OTTAWA, ONTARIO K2E 7J5
TEL. (613) 727-8226 FAX. (613) 727-1826

REGISTERED PLAN 399
LOT 9

949 North River Road– Infrastructure Notes

Available Infrastructure:

Ontario Street:

Sanitary: 225mm Conc (Install 1967)

Storm: 600mm Conc (Install 1967)

Water: 150mm UCI (Install unknown)

North River Road:

Sanitary: 1950mm Conc (Install 2007)

Storm: 900mm Conc (Install 1968)

Water: 200mm PVC (Install 1995)

Note: Infrastructure is available on North River Road however the preferred connection is Ontario Street as the sewer mains on North River Road are collector sewers (trunk sewers).

Water Boundary Conditions:

Will be provided at request of consultant. Requests must include the location of the service and the expected loads required by the proposed development. Please provide the following and submit Fire Flow Calculation Sheet per FUS method with the request:

- Location of service
- Type of development and amount of required fire flow (per FUS method – include FUS calculation sheet with request)
- Average Daily Demand (l/s)
- Maximum Hourly Demand (l/s)
- Maximum Daily Demand (l/s)
- Water Supply Redundancy – Fire Flow:
Applicant to ensure that a second service with an inline valve chamber be provided where the average daily demand exceeds 50 m³ / day (0.5787 l/s per day)

Water services larger than 19 mm require a Water Data Card. Please complete card and submit.

Stormwater Management (Quantity Control):

- Coefficient (C) of runoff determined **as per existing conditions** but in no case more than 0.5.
- TC = To be calculated, minimum 10 minutes
- Any storm events greater than 2 year, up to 100 year, and including 100-year storm event must be detained on site.
- Foundation drains are to be independently connected to sewer main unless being pumped with appropriate back up power, sufficient sized pump and back flow prevention.
- Roof drains are to be connected downstream of any incorporated ICD within the SWM system.

Stormwater Management (Quality Control):

- Rideau Valley Conservation Authority to provide Quality Controls.

Noise Study:

- Noise study required – property fronts a Collector Road (North River Road).

Phase I and Phase II ESA:

- Phase I ESA is required; Phase II ESA may be required depending on the results of the Phase I ESA. Phase I ESA must include an EcoLog ERIS Report.
- Phase I ESA and Phase II ESAs must conform to clause 4.8.4 of the Official Plan that requires that development applications conform to Ontario Regulation 153/04.

Required Studies

- Stormwater Management Report
- Site Servicing Study
- Geotechnical Study
- Phase I ESA
- Phase II ESA (depends on outcome of Phase I)
- Noise Study

Required Plans

- Site Servicing Plan
- Grade Control and Drainage Plan
- Erosion and Sediment Control Plan (Can be combined with Grading Plan)

Relevant information

1. The Servicing Study Guidelines for Development Applications are available at the following address: <https://ottawa.ca/en/city-hall/planning-and-development/information-developers/development-application-review-process/development-application-submission/guide-preparing-studies-and-plans#servicing-study-guidelines-development-applications>
2. Servicing and site works shall be in accordance with the following documents:
 - ⇒ Ottawa Sewer Design Guidelines (October 2012)
 - ⇒ Ottawa Design Guidelines – Water Distribution (2010)
 - ⇒ Geotechnical Investigation and Reporting Guidelines for Development Applications in the City of Ottawa (2007)
 - ⇒ City of Ottawa Slope Stability Guidelines for Development Applications (revised 2012)
 - ⇒ City of Ottawa Environmental Noise Control Guidelines (January 2016)
 - ⇒ City of Ottawa Park and Pathway Development Manual (2012)
 - ⇒ City of Ottawa Accessibility Design Standards (2012)
 - ⇒ Ottawa Standard Tender Documents (latest version)
 - ⇒ Ontario Provincial Standards for Roads & Public Works (2013)

3. Record drawings and utility plans are also available for purchase from the City (Contact the City's Information Centre by email at InformationCentre@ottawa.ca or by phone at (613) 580-2424 x.44455).
4. Any proposed work in utility easements requires written consent of easement owner.

APPENDIX C
WATERMAIN CALCULATIONS

McINTOSH PERRY

COO-21-2796 - 949 North River Road - Water Demands

Project:	949 North River Road
Project No.:	COO-21-2796
Designed By:	FV
Checked By:	AG
Date:	February 18, 2022
Site Area:	0.17 gross ha

Residential	NUMBER OF UNITS	UNIT RATE	
Water Supply for Fire-Fighting - Apartment Building	homes	3.4	persons/unit
Semi-detached	homes	2.7	persons/unit
Townhouse	homes	2.7	persons/unit
Bachelor Apartment	units	1.4	persons/unit
1 Bedroom Apartment	30 units	1.4	persons/unit
2 Bedroom Apartment	16 units	2.1	persons/unit
3 Bedroom Apartment	units	3.1	persons/unit
Average Apartment	units	1.8	persons/unit
Total Population	76 persons		
Amenity	443 m2		
Industrial - Light	m2		
Industrial - Heavy	m2		

AVERAGE DAILY DEMAND

DEMAND TYPE	AMOUNT	UNITS	
Residential	280	L/c/d	
Industrial - Light	35,000	L/gross ha/d	
Industrial - Heavy	55,000	L/gross ha/d	
Shopping Centres	2,500	L/(1000m ² /d)	
Hospital	900	L/(bed/day)	
Schools	70	L/(Student/d)	
Trailer Park with no Hook-Ups	340	L/(space/d)	
Trailer Park with Hook-Ups	800	L/(space/d)	
Campgrounds	225	L/(campsite/d)	
Mobile Home Parks	1,000	L/(Space/d)	
Motels	150	L/(bed-space/d)	
Hotels	225	L/(bed-space/d)	
Tourist Commercial	28,000	L/gross ha/d	
Other Commercial	28,000	L/gross ha/d	
AVERAGED DAILY DEMAND	Residential	0.25	L/s
	Commercial/ Industrial / Institutional	0.01	L/s

MAXIMUM DAILY DEMAND

DEMAND TYPE	AMOUNT	UNITS	
Residential	5.4	x avg. day	L/c/d
Industrial	1.5	x avg. day	L/gross ha/d
Commercial	1.5	x avg. day	L/gross ha/d
Institutional	1.5	x avg. day	L/gross ha/d
MAXIMUM DAILY DEMAND	Residential	1.33	L/s
	Commercial/ Industrial / Institutional	0.02	L/s

MAXIMUM HOUR DEMAND

DEMAND TYPE	AMOUNT	UNITS	
Residential	8.1	x avg. day	L/c/d
Industrial	1.8	x max. day	L/gross ha/d
Commercial	1.8	x max. day	L/gross ha/d
Institutional	1.8	x max. day	L/gross ha/d
MAXIMUM HOUR DEMAND	Residential	2.00	L/s
	Commercial/ Industrial / Institutional	0.04	L/s

WATER DEMAND DESIGN FLOWS PER UNIT COUNT
CITY OF OTTAWA - WATER DISTRIBUTION GUIDELINES, JULY 2010

AVERAGED DAILY DEMAND	0.26	L/s
MAXIMUM DAILY DEMAND	1.35	L/s
MAXIMUM HOUR DEMAND	2.03	L/s

McINTOSH PERRY

000-21-2796 - 949 North River Road - Fire Underwriters Survey

Project: 949 North River Road
 Project No.: 000-21-2796
 Designed By: FV
 Checked By: AG
 Date: February 18, 2022

From the Fire Underwriters Survey (1999)

Water Sup From Part II – Guide for Determination of Required Fire Flow Copyright I.S.O.:
 Updated per City of Ottawa Technical Bulletin ISTB-2018-02

A. BASE REQUIREMENT (Rounded to the nearest 1000 L/ min)

F = 220 x C x √A Where: F = Required fire flow in liters per minute
 C = Coefficient related to the type of construction.
 A = The total floor area in square meters (including all storey's, but excluding basements at least 50 percent below grade) in the building being considered.

Construction Type **Non-Combustible Construction**

C 0.8 A 5,400.0 m²

Calculated Fire Flow	12,933.3 L/ min
	13,000.0 L/ min

B. REDUCTION FOR OCCUPANCY TYPE (No Rounding)

From note 2, Page 18 of the Fire Underwriter Survey:
 Limited Combustible -15%

Fire Flow	11,050.0 L/ min
-----------	-----------------

C. REDUCTION FOR SPRINKLER TYPE (No Rounding)

Fully Supervised Sprinklered -50%

Reduction	-5,525.0 L/ min
-----------	-----------------

D. INCREASE FOR EXPOSURE (No Rounding)

	Separation Distance (m)	Cons.of Exposed Wall	Length Exposed Adjacent Wall (m)	Height (Stories)	Length-Height Factor	
Exposure 1	3.1 to 10	Non-Combustible	15	4	60.0	18%
Exposure 2	3.1 to 10	Non-Combustible	30	3	90.0	19%
Exposure 3	10.1 to 20	Non-Combustible	30	4	120.0	15%
Exposure 4	20.1 to 30	Wood frame	10	2	20.0	8%

% Increase* 60%

5.4

Increase*	6,630.0 L/ min
-----------	----------------

E. Total Fire Flow (Rounded to the Nearest 1000 L/ min)

Fire Flow	12,155.0 L/ min
Fire Flow Required**	12,000.0 L/ min

* In accordance with Part II, Section 4, the Increase for separation distance is not to exceed 75%

** In accordance with Section 4 the Fire flow is not to exceed 45,000 L/ min or be less than 2,000 L/ min

McINTOSH PERRY

000-21-2796 - 949 North River Road - Boundary Condition Unit Conversion

Project: 949 North River Road

Project No.: 000-21-2796

Designed By: FV

Checked By: AG

Date: February 18, 2022

Boundary Conditions Unit Conversion

Ontario Street

Scenario	Height (m)	Elevation (m)	m H ₂ O	PSI	kPa
Avg. DD	118.5	58.4	60.1	85.5	589.4
Fire Flow (267 L/s or 16,000 L/min)	89.2	58.4	30.8	43.8	302.0
Peak Hour	109.5	58.4	51.1	72.7	501.1

Hydrant Cover Figure - 949 North River Road

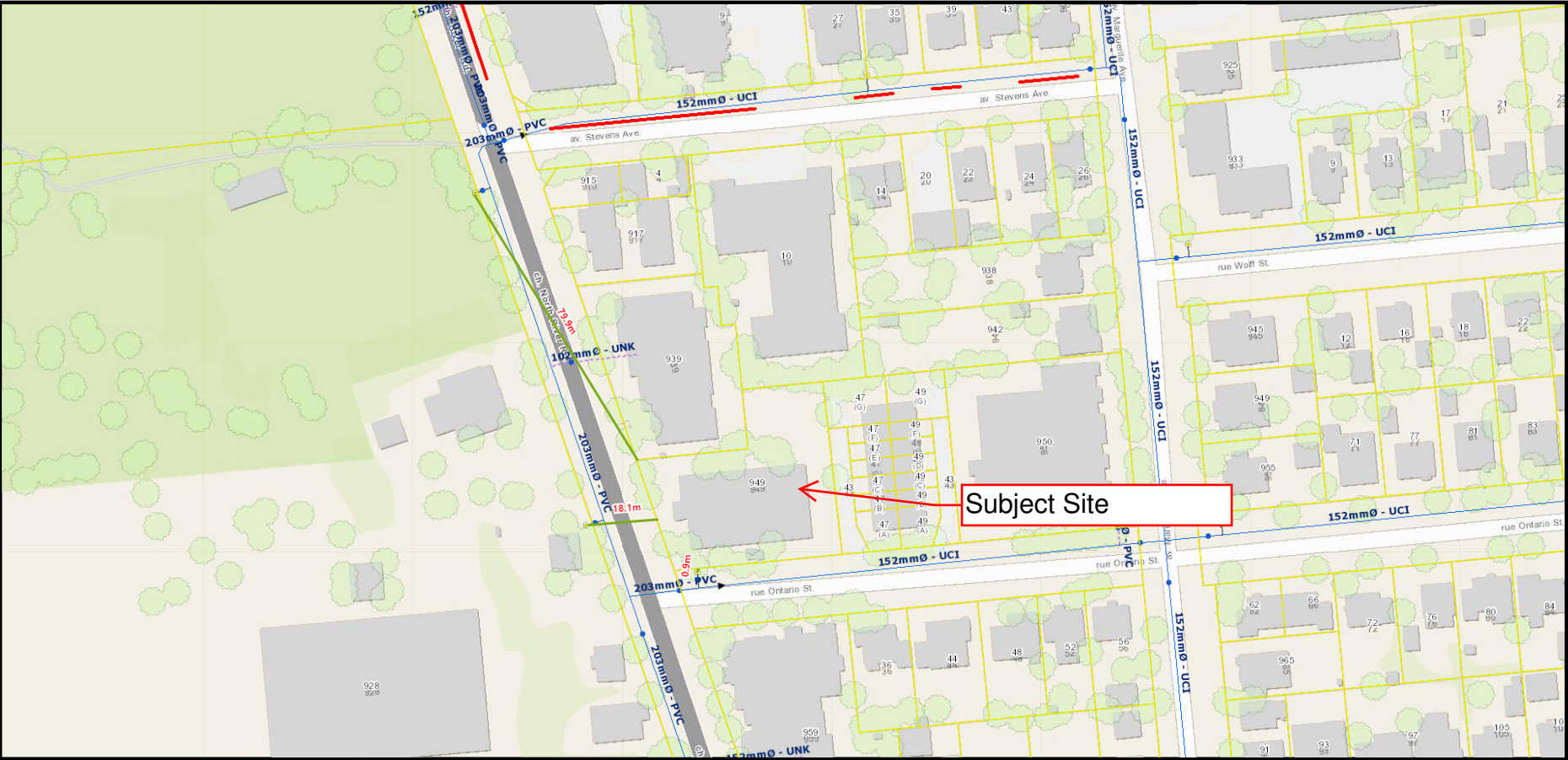

Boundary Conditions for 949 North River Road



From: Robert Freel
Sent: July 27, 2021 3:19 PM
To: Ryan Robineau
Subject: FW: 949 North River Road - Boundary Condition Request
Attachments: 949 North River Road July 2021.pdf

Hi Ryan,

Boundary conditions for North River attached.

Thank you,
Bobby

Robert Freel, P.Eng.

Senior Project Manager, Land Development
T. 613.714.6174 | C. 613.915.3815

McINTOSH PERRY

Turning Possibilities Into Reality

From: Fawzi, Mohammed <mohammed.fawzi@ottawa.ca>
Sent: July 27, 2021 3:13 PM
To: Robert Freel <rfreel@mcintoshperry.com>
Subject: RE: 949 North River Road - Boundary Condition Request

Hi Robert,

The following are boundary conditions, HGL, for hydraulic analysis at (zone 1E) assumed to be a dual connection to the 203 mm on Ontario Street (see attached PDF for location).

Minimum HGL: 109.5 m

Maximum HGL: 118.5 m

Max Day + Fire Flow (200 L/s): 89.2 m

The maximum pressure is estimated to be more than 80 psi. A pressure check at completion of construction is recommended to determine if pressure control is required.

These are for current conditions and are based on computer model simulation.

Disclaimer: The boundary condition information is based on current operation of the city water distribution system. The computer model simulation is based on the best information available at the time. The operation of the water distribution system can change on a regular basis, resulting in a variation in boundary conditions. The physical properties of watermain deteriorate over time, as such must be assumed in the absence of actual field test data. The variation in physical watermain properties can therefore alter the results of the computer model simulation.

Best Regards,

Mohammed Fawzi, E.I.T.

Project Manager
Planning, Infrastructure and Economic Development Department - Services de la planification, de l'infrastructure et du développement économique
Development Review - Central Branch
City of Ottawa | Ville d'Ottawa
110 Laurier Avenue West Ottawa, ON | 110, avenue. Laurier Ouest. Ottawa (Ontario) K1P 1J1
613.580.2424 ext./poste 20120, Mohammed.Fawzi@ottawa.ca

From: Fawzi, Mohammed
Sent: July 22, 2021 9:19 AM
To: Robert Freel <rfreel@mcintoshperry.com>
Subject: RE: 949 North River Road - Boundary Condition Request

Hi Robert,

This email is to confirm that your request has been received.

Thank you.

Best Regards,

Mohammed Fawzi, E.I.T.

Project Manager
Planning, Infrastructure and Economic Development Department - Services de la planification, de l'infrastructure et du développement économique
Development Review - Central Branch
City of Ottawa | Ville d'Ottawa
110 Laurier Avenue West Ottawa, ON | 110, avenue. Laurier Ouest. Ottawa (Ontario) K1P 1J1
613.580.2424 ext./poste 20120, Mohammed.Fawzi@ottawa.ca

From: Robert Freel <rfreel@mcintoshperry.com>
Sent: July 21, 2021 11:34 AM
To: Fawzi, Mohammed <mohammed.fawzi@ottawa.ca>
Subject: 949 North River Road - Boundary Condition Request

CAUTION: This email originated from an External Sender. Please do not click links or open attachments unless you recognize the source.

ATTENTION : Ce courriel provient d'un expéditeur externe. Ne cliquez sur aucun lien et n'ouvrez pas de pièce jointe, excepté si vous connaissez l'expéditeur.

Good morning Mohammed,

We would like to request Boundary Conditions for 949 North River Road. The proposed development is a 5-storey apartment building with 48 units and 5,400 m² of floor area.

- The estimated fire flow is 12,000 L/min based on the FUS
- Average daily demand: 0.29 l/s.
- Maximum daily demand: 1.38 l/s.
- Maximum hourly daily demand: 2.09 l/s.

Attached is a map showing the proposed connection location along with the calculations prepared for the demands listed above.

If there are any questions, please feel free to contact me.

Thank you,
Bobby

Robert Freel, P.Eng.

Senior Project Manager, Land Development

115 Walgreen Road, Carp, ON K2E 6L5

T. 613.714.6174 | C. 613.915.3815

r.freel@mcintoshperry.com | www.mcintoshperry.com

McINTOSH PERRY

Turning Possibilities Into Reality

Confidentiality Notice – If this email wasn't intended for you, please return or delete it. [Click here](#) to read all of the legal language around this concept.



This e-mail originates from the City of Ottawa e-mail system. Any distribution, use or copying of this e-mail or the information it contains by other than the intended recipient(s) is unauthorized. Thank you.

Le présent courriel a été expédié par le système de courriels de la Ville d'Ottawa. Toute distribution, utilisation ou reproduction du courriel ou des renseignements qui s'y trouvent par une personne autre que son destinataire prévu est interdite. Je vous remercie de votre collaboration.

APPENDIX D
SANITARY CALCULATIONS

McINTOSH PERRY

000-21-2796 - 949 North River Road - Sanitary Demands

Project:	949 North River Road	
Project No.:	000-21-2796	
Designed By:	FV	
Checked By:	AG	
Date:	02/ 18/ 2022	
Site Area:	0.17 gross ha	
1 Bedroom	30	1.4 Persons per Unit
2 Bedroom	16	2.1 Persons per Unit
Total Population	76	Persons
Commercial Area	0.00 m ²	
Amenity Space	443.00 m ²	

EXTRANEIOUS FLOW ALLOWANCES

Infiltration / Inflow	Flow (L/s)
Dry	0.01
Wet	0.05
Total	0.06

AVERAGE DAILY DEMAND

DEMAND TYPE	AMOUNT	UNITS	NUMBER OF UNITS/ AREA	Flow (L/s)
Residential	280	L/ c/ d	76	0.25
Industrial - Light**	35,000	L/gross ha/ d		0
Industrial - Heavy**	55,000	L/gross ha/ d		0
Commercial / Amenity	2,500	L/ (1000m ² /d)	443.00	0.01
Hospital	900	L/ (bed/ day)		0
Schools	70	L/ (Student/ d)		0
Trailer Parks no Hook-Ups	340	L/ (space/ d)		0
Trailer Park with Hook-Ups	800	L/ (space/ d)		0
Campgrounds	225	L/ (campsite/ d)		0
Mobile Home Parks	1,000	L/ (Space/ d)		0
Motels	150	L/ (bed-space/ d)		0
Hotels	225	L/ (bed-space/ d)		0
Tourist Commercial	28,000	L/ gross ha/ d		0
Other Commercial	28,000	L/ gross ha/ d		0

AVERAGE RESIDENTIAL FLOW	0.25	L/ s
PEAK RESIDENTIAL FLOW	0.89	L/ s
AVERAGE ICI FLOW	0.01	L/ s
PEAK INSTITUTIONAL/ COMMERCIAL FLOW	0.02	L/ s
PEAK INDUSTRIAL FLOW **	0.00	L/ s
TOTAL PEAK ICI FLOW	0.02	L/ s

TOTAL SANITARY DEMAND

TOTAL ESTIMATED AVERAGE DRY WEATHER FLOW	0.27	L/ s
TOTAL ESTIMATED PEAK DRY WEATHER FLOW	0.92	L/ s
TOTAL ESTIMATED PEAK WET WEATHER FLOW	0.97	L/ s

** PEAK INDUSTRIAL FLOW PER CITY OF OTTAWA SEWER DESIGN GUIDELINES APPENDIX 4B

APPENDIX E
PRE-DEVELOPMENT DRAINAGE PLAN

FILENAME: U:\Ottawa\01 - Project - Proposals\2021 jobs\CCO\CCO-21-2796 Gemstone - 949 N River Road\12 - Drawings\CCO-21-2796_Presentation.dwg
 LAST PLOTTED: Thursday, March 03, 2022 3:17:03 PM
 USER: j.tobin

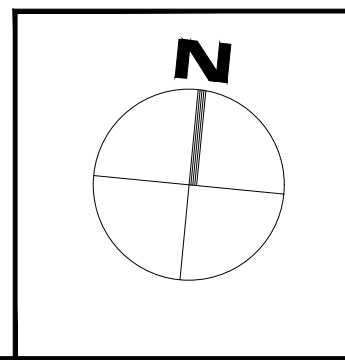
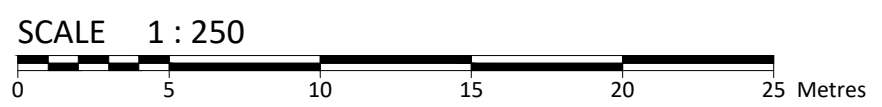
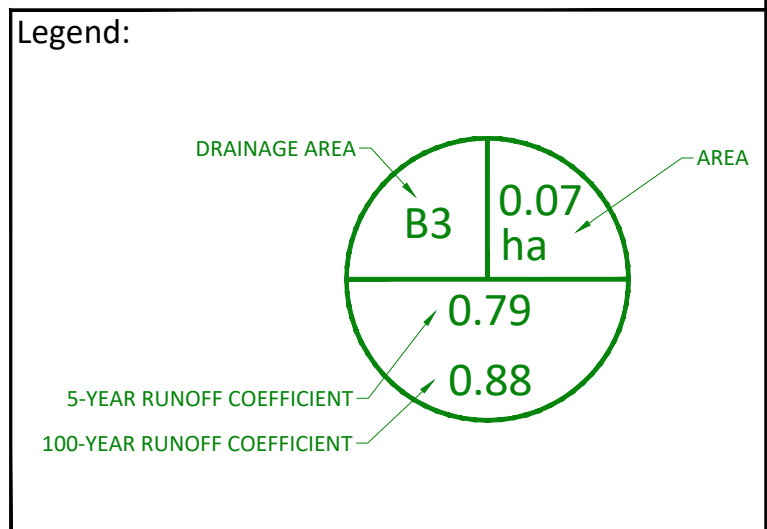
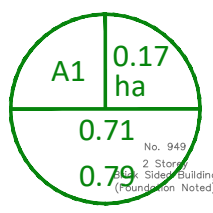
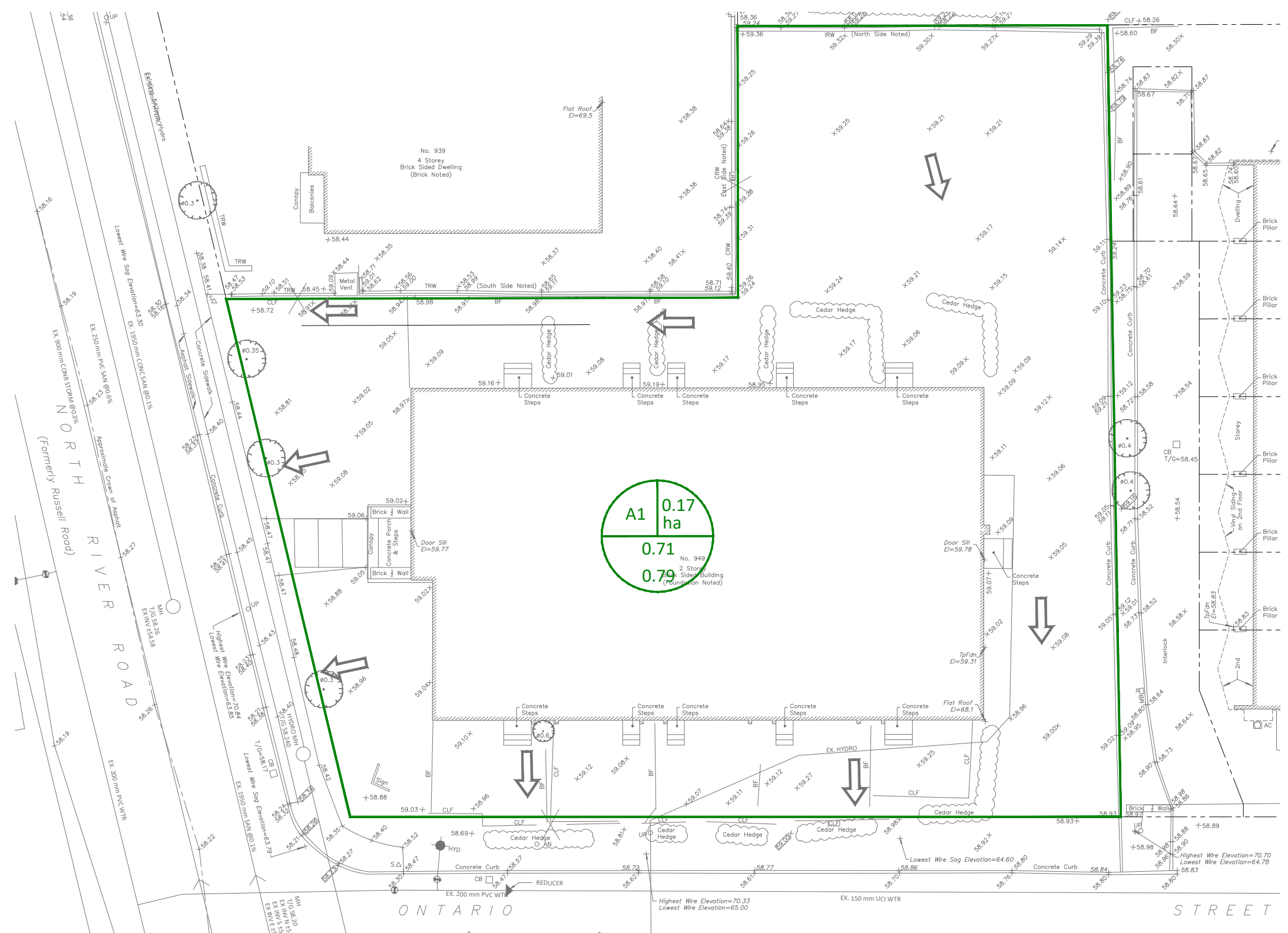

McINTOSH PERRY
 115 Walgreen Road, RR3, Carp, ON K0A 1L0
 Tel: 613-836-2184 Fax: 613-836-3742
 www.mcintoshperry.com

Drawn by:	R.R.R.	Checked By:	R.D.F.
Scale:	1:250	Project Number:	CCO-21-2796

Client:	GEMSTONE DEVELOPMENTS 252 ARGYLE STREET OTTAWA, ON K2P 1B9		
Project:	5-STORY RESIDENTIAL BUILDING 949 NORTH RIVER ROAD		
Drawing Title:	PRE-DEVELOPMENT DRAINAGE AREA PLAN		
Drawn by:	R.R.R.	Checked By:	R.D.F.
Scale:	1:250	Project Number:	CCO-21-2796
No.	Revisions	Date	Drawing Number:
2	ISSUED FOR REVIEW	MAR 04, 2022	PRE
1	ISSUED FOR REVIEW	SEPT 24, 2021	

D07-12-21-0150

APPENDIX F
POST-DEVELOPMENT DRAINAGE PLAN

FILENAME: U:\Ottawa\01 - Projects - Proposals\2021 Jobs\CCO\CCO-21-2796 Gemstone - 949 N River Road\12 - Drawings\CCO-21-2796_Presentation.dwg
 LAST PLOTTED: Friday, March 04, 2022, 10:58:45 AM
 CIB FILE USED: ...

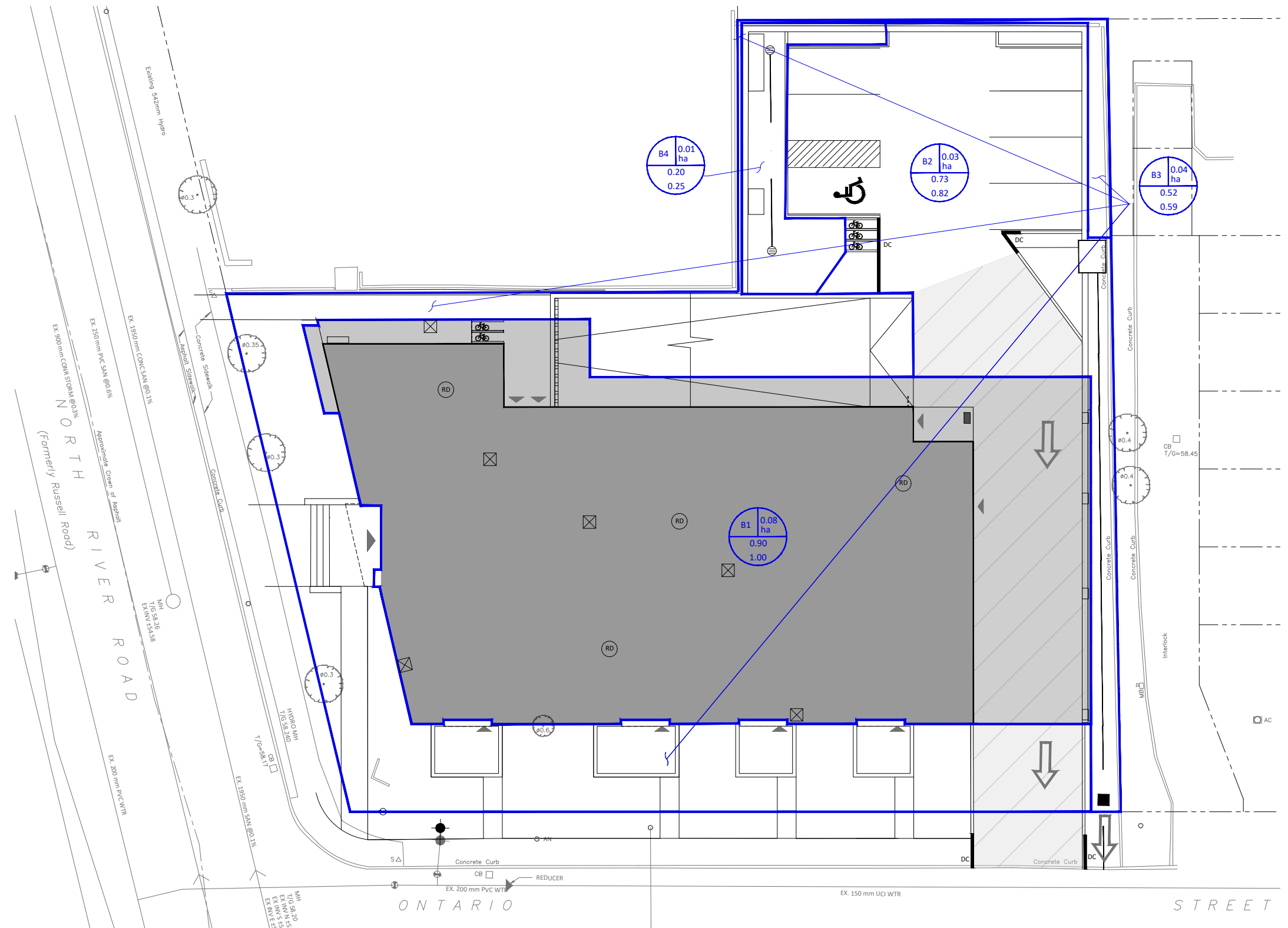

ROOF DRAINS (B1)		
TYPE OF CONTROL DEVICE	WATTS DRAINAGE RD-100-A-ADJ (FULLY EXPOSED)	
NUMBER OF ROOF DRAINS	4	
SCENARIO	5-YEAR	100-YR
ROOFTOP STORAGE (m ³)	22.04	37.79
DEPTH OF FLOW (m)	0.035	0.060
FLOW PER ROOF DRAIN (L/s)	0.44	0.76
TOTAL RESTRICTED FLOW	1.76	3.04

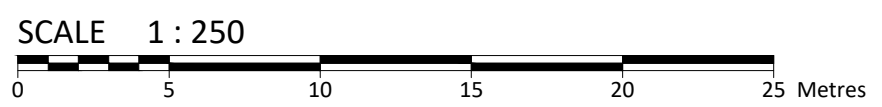
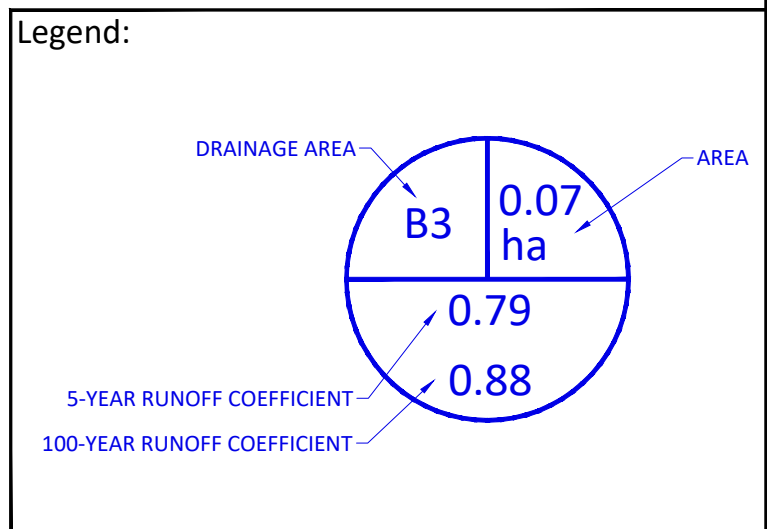

	<h2>McINTOSH PERRY</h2> <p>115 Walgreen Road, RR3, Carp, ON K0A 1L0 Tel: 613-836-2184 Fax: 613-836-3742 www.mcintoshperry.com</p>		Client: GEMSTONE DEVELOPMENTS 252 ARGYLE STREET OTTAWA, ON K2P 1B9	
	Project: 5-STOREY RESIDENTIAL BUILDING 949 NORTH RIVER ROAD		Drawing Title: POST-DEVELOPMENT DRAINAGE AREA PLAN	
Drawn by: R.R.R.	Checked By: R.D.F.	No. 2	ISSUED FOR REVIEW	Date MAR 04, 2022
Scale: 1:250	Project Number: CCO-21-2796	No. 1	ISSUED FOR REVIEW	Date SEPT 24, 2021
			Drawing Number: POST	#18583

D07-12-21-0150

APPENDIX G
STORMWATER MANAGEMENT CALCULATIONS

McINTOSH PERRY

CCO-21-2796 - 949 North River Road - Runoff Calculations

1 of 5

Pre-Development Runoff Coefficient

Drainage Area	Area (ha)	Impervious Area (m ²)	C	Gravel Area (m ²)	C	Pervious Area (m ²)	C	C _{AVG} 2/5-Year	C _{AVG} 100-Year
A1	0.168	1,210.51	0.90	0.00	0.60	464.98	0.20	0.71	0.79

Pre-Development Runoff Calculations

Drainage Area	Area (ha)	C 2/5-Year	C 100-Year	Tc (min)	I (mm/hr)			Q (L/S)	
					2-Year	5-Year	100-Year	5-Year	100-Year
A1	0.168	0.71	0.79	10	76.8	104.2	178.6	34.25	65.86
Total	0.168							34.25	65.86

Post-Development Runoff Coefficient

Drainage Area	Area (ha)	Impervious Area (m ²)	C	Gravel Area (m ²)	C	Pervious Area (m ²)	C	C _{AVG} 2/5-Year	C _{AVG} 100-Year
B1	0.084	839.80	0.90	0.00	0.60	0.00	0.20	0.90	1.00
B2	0.032	242.14	0.90	0.00	0.60	75.93	0.20	0.73	0.82
B3	0.045	205.05	0.90	0.00	0.60	244.82	0.20	0.52	0.59
B4	0.007	0.00	0.90	0.00	0.60	67.75	0.20	0.20	0.25

Roof
Restricted Parking Lot Area
Unrestricted
Unrestricted

Post-Development Runoff Calculations

Drainage Area	Area (ha)	C 2/5-Year	C 100-Year	Tc (min)	I (mm/hr)		Q (L/S)	
					5-Year	100-Year	5-Year	100-Year
B1	0.084	0.90	1.00	10	104.2	178.6	21.89	41.69
B2	0.032	0.73	0.82	10	104.2	178.6	6.75	12.96
B3	0.045	0.52	0.59	10	104.2	178.6	6.76	13.22
B4	0.007	0.20	0.25	10	104.2	178.6	0.39	0.84
Total	0.168						35.80	68.71

Required Restricted Flow

Drainage Area	Area (ha)	C 5-Year	Tc (min)	I (mm/hr)	Q (L/s)
				5-Year	5-Year
A1	0.168	0.50	10	104.2	24.27

Post-Development Restricted Runoff Calculations

Drainage Area	Unrestricted Flow (L/s)		Restricted Flow (L/S)		Storage Required (m ³)		Storage Provided (m ³)	
	5-Year	100-Year	5-Year	100-Year	5-Year	100-Year	5-Year	100-Year
B1	21.89	41.69	1.76	3.04	18.58	36.05	22.04	37.79
B2	6.75	12.96	1.80	3.00	3.30	6.85	11.56	11.56
B3	6.76	13.22	6.76	13.22				
B4	0.39	0.84	0.39	0.84				
Total	35.80	68.71	10.72	20.10	21.89	42.90	33.60	49.35

McINTOSH PERRY

Storage Requirements for Area B1

5-Year Storm Event

Tc (min)	I (mm/hr)	B1 Runoff (L/s)	Allowable Outflow (L/s)	Runoff to be Stored (L/s)	Storage Required (m ³)
10	104.2	21.89	1.76	20.13	12.08
20	70.3	14.76	1.76	13.00	15.60
30	53.9	11.33	1.76	9.57	17.23
40	44.2	9.28	1.76	7.52	18.06
50	37.7	7.91	1.76	6.15	18.45
60	32.9	6.92	1.76	5.16	18.58
70	29.4	6.17	1.76	4.41	18.53
80	26.6	5.58	1.76	3.82	18.34
90	24.3	5.10	1.76	3.34	18.05
100	22.4	4.71	1.76	2.95	17.69

Maximum Storage Required 5-Year (m³) = 18.58

100-Year Storm Event

Tc (min)	I (mm/hr)	B1 Runoff (L/s)	Allowable Outflow (L/s)	Runoff to be Stored (L/s)	Storage Required (m ³)
10	178.6	41.69	3.04	38.65	23.19
20	120.0	28.00	3.04	24.96	29.96
30	91.9	21.45	3.04	18.41	33.13
40	75.1	17.54	3.04	14.50	34.81
50	64.0	14.93	3.04	11.89	35.67
60	55.9	13.05	3.04	10.01	36.03
70	49.8	11.62	3.04	8.58	36.05
80	45.0	10.50	3.04	7.46	35.83

Maximum Storage Required 100-Year (m³) = 36.05

Storage Occupied In Area B1

5-Year Storm Event

Roof Storage			
Location	Area*	Depth	Volume (m ³)
Roof	629.85	0.035	22.04
Total			22.04

Storage Available (m³) = 22.04
Storage Required (m³) = 18.58

100-Year Storm Event

Roof Storage			
Location	Area*	Depth	Volume (m ³)
Roof	629.85	0.060	37.79
Total			37.79

Storage Available (m³) = 37.79
Storage Required (m³) = 36.05

* Area is 75% of the total roof area

McINTOSH PERRY

Roof Drain Flow (B1)

Roof Drains Summary		
Type of Control Device	Watts Drainage - Accutrol Weir	
Number of Roof Drains	4	
	5-Year	100-Year
Rooftop Storage (m ³)	22.04	37.79
Storage Depth (m)	0.035	0.060
Flow (Per Roof Drain) (L/s)	0.44	0.76
Total Flow (L/s)	1.76	3.04

Flow Rate Vs. Build-Up (One Weir)	
Depth (mm)	Flow (L/s)
15	0.19
20	0.25
25	0.32
30	0.38
35	0.44
40	0.50
45	0.57
50	0.63
55	0.69

Roof Drain Flow			
	Flow (l/s)	Storage Depth (mm)	Drains Flow (l/s)
	0.19	15	0.76
	0.25	20	1.00
	0.32	25	1.28
	0.38	30	1.52
5-Year	0.44	35	1.76
	0.50	40	2.00
	0.57	45	2.28
	0.63	50	2.52
100-Year	0.76	60	3.04
	0.82	65	3.28
	0.88	70	3.52
	0.95	75	3.80
	1.01	80	4.04
	1.07	85	4.28
	1.13	90	4.52
	1.20	95	4.80
	1.26	100	5.04
	1.32	105	5.28
	1.39	110	5.56
	1.45	115	5.80
	1.51	120	6.04
	1.58	125	6.32
	1.64	130	6.56
	1.70	135	6.80
	1.76	140	7.04
	1.83	145	7.32
	1.89	150	7.56

* Roof Drain model to be Accutrol Weirs, See attached sheets

* Roof Drain Flow information taken from Watts Drainage website

CALCULATING ROOF FLOW EXAMPLES

2 roof drains during a 5 year storm
 elevation of water = 30mm
 Flow leaving 2 roof drains = (2 x 0.36 L/s) = 0.72 L/s

2 roof drains during a 100 year storm
 elevation of water = 45mm
 Flow leaving 2 roof drains = (2 x 0.54 L/s) = 1.08 L/s

Note: The flow leaving through a restricted roof drain is based on flow vs. head information

McINTOSH PERRY

Storage Requirements for Area B2

5-Year Storm Event

Tc (min)	I (mm/hr)	B1 Runoff (L/s)	Allowable Outflow (L/s)	Runoff to be Stored (L/s)	Storage Required (m ³)
10	104.2	6.75	1.80	4.95	2.97
15	83.6	5.41	1.80	3.61	3.25
20	70.3	4.55	1.80	2.75	3.30
25	60.9	3.95	1.80	2.15	3.22
30	53.9	3.49	1.80	1.69	3.05
35	48.5	3.14	1.80	1.34	2.82
40	44.2	2.86	1.80	1.06	2.55

Maximum Storage Required 5-Year (m³) = 3.30

100-Year Storm Event

Tc (min)	I (mm/hr)	B1 Runoff (L/s)	Allowable Outflow (L/s)	Runoff to be Stored (L/s)	Storage Required (m ³)
10	178.6	12.96	3.00	9.96	5.98
15	142.9	10.37	3.00	7.37	6.64
20	120.0	8.71	3.00	5.71	6.85
25	103.8	7.54	3.00	4.54	6.81
30	91.9	6.67	3.00	3.67	6.60
35	82.6	5.99	3.00	2.99	6.29
40	75.1	5.45	3.00	2.45	5.89

Maximum Storage Required 100-Year (m³) = 6.85

Storage Available in Drainage Trench Void Space and Perforated Storm Pipe

Length (m)	Width (m)	Height (m)	Void Fraction	Pipe Diameter (m)
29.67	0.90	1.00	0.40	0.25

$$V = (A_t - A_p) * V_f * L + V_p$$

V = Storage Available
 A_t = Trench Area Above Pipe Invert
 A_p = Pipe Area
 V_f = Void Fraction of 25 mm Clear Stone
 L = Trench Length
 V_p = Volume of Pipe
 $V = ((0.90 * 1.00) - (\pi(0.25/2)^2) * 0.4 * 29.67 + ((\pi(0.25/2)^2) * 29.67)$

5 Year Storage Summary

Storage Available (m ³) =	11.6
Storage Required (m ³) =	3.3

* Storage Available in Drainage Trench Void Space and Perforated Storm Pipe

100 Year Storage Summary

Storage Available (m ³) =	11.6
Storage Required (m ³) =	6.8

* Storage Available in Drainage Trench Void Space and Perforated Storm Pipe

McINTOSH PERRY

CCO-21-2796 - 949 North River Road - Runoff Calculations

5 of 5

Time of Concentration Pre-Development

Drainage Area ID	Sheet Flow Distance (m)	Slope of Land (%)	Tc (min) (5-Year)	Tc (min) (100-Year)
A1	39	0.76	7	5

Therefore, a Tc of 10 can be used

$$T_c = (3.26(1.1-c)L^{0.5}/S^{0.33})$$

c= Blanced Runoff Coefficient

L= Length of drainage area

S= Average slope of watershed



Adjustable Accutrol Weir
 Tag: _____

**Adjustable Flow Control
 for Roof Drains**

ADJUSTABLE ACCUTROL (for Large Sump Roof Drains only)

For more flexibility in controlling flow with heads deeper than 2", Watts Drainage offers the Adjustable Accutrol. The Adjustable Accutrol Weir is designed with a single parabolic opening that can be covered to restrict flow above 2" of head to less than 5 gpm per inch, up to 6" of head. To adjust the flow rate for depths over 2" of head, set the slot in the adjustable upper cone according to the flow rate required. Refer to Table 1 below.
 Note: Flow rates are directly proportional to the amount of weir opening that is exposed.

EXAMPLE:

For example, if the adjustable upper cone is set to cover 1/2 of the weir opening, flow rates above 2" of head will be restricted to 2-1/2 gpm per inch of head.

Therefore, at 3" of head, the flow rate through the Accutrol Weir that has 1/2 the slot exposed will be:
 [5 gpm (per inch of head) x 2 inches of head] + 2-1/2 gpm (for the third inch of head) = 12-1/2 gpm.

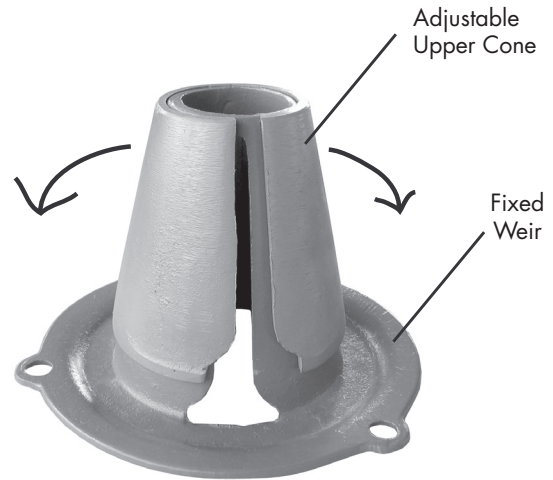
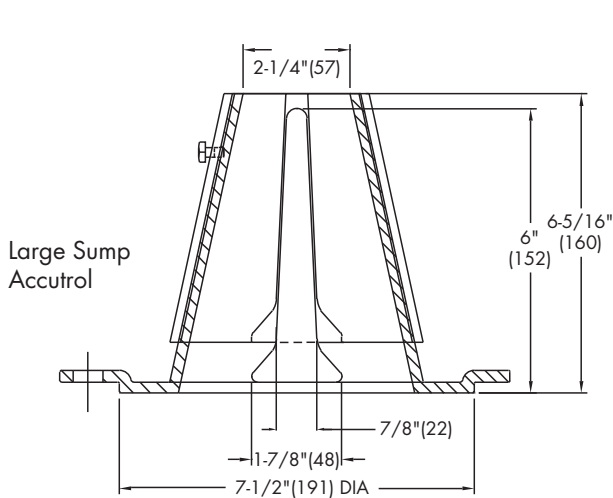

1/2 Weir Opening Exposed Shown Above

TABLE 1. Adjustable Accutrol Flow Rate Settings

Weir Opening Exposed	1"	2"	3"	4"	5"	6"
	Flow Rate (gallons per minute)					
Fully Exposed	5	10	15	20	25	30
3/4	5	10	13.75	17.5	21.25	25
1/2	5	10	12.5	15	17.5	20
1/4	5	10	11.25	12.5	13.75	15
Closed	5	5	5	5	5	5

Job Name _____
 Job Location _____
 Engineer _____

Contractor _____
 Contractor's P.O. No. _____
 Representative _____

Watts product specifications in U.S. customary units and metric are approximate and are provided for reference only. For precise measurements, please contact Watts Technical Service. Watts reserves the right to change or modify product design, construction, specifications, or materials without prior notice and without incurring any obligation to make such changes and modifications on Watts products previously or subsequently sold.

USA: Tel: (800) 338-2581 • Fax: (828) 248-3929 • Watts.com
 Canada: Tel: (905) 332-4090 • Fax: (905) 332-7068 • Watts.ca
 Latin America: Tel: (52) 81-1001-8600 • Fax: (52) 81-8000-7091 • Watts.com



A Watts Water Technologies Company

FLOW CONTROL ROOF DRAINAGE DECLARATION

THIS FORM TO BE COMPLETED BY THE MECHANICAL AND STRUCTURAL ENGINEERS RESPONSIBLE FOR DESIGN

Permit Application No.

Project Name:

949 North River Road

Building Location:

949 North River Road, Ottawa, ON

Municipality:

City of Ottawa

The roof drainage system has been designed in accordance with the following criteria: (please check one of the following).

- M1. Conventionally drained roof (no flow control roof drains used).
- M2. Flow control roof drains meeting the following conditions have been incorporated in this design:
- (a) the maximum drain down time does not exceed 24h,
 - (b) one or more scuppers are installed so that the maximum depth of water on the roof cannot exceed 150mm,
 - (c) drains are located not more than 15m from the edge of roof and not more than 30m from adjacent drains, and
 - (d) there is at least one drain for each 900 sq.m.
- M3. A flow control drainage system that does not meet the minimum drainage criteria described in M2 has been incorporated in this design.

PROFESSIONAL SEAL APPLIED BY:

Practitioner's Name:

Elaine Guenette

Firm:

Smith + Andersen

Phone #:

613 691 1853

City:

Ottawa

Province:

ON



Mechanical Engineer's Seal

- S1. The design parameters incorporated into the overall structural design are consistent with the information provided by the Mechanical Engineer in M2. Loads due to rain are not considered to act simultaneously with loads due to snow as per Sentence 4.1.7.3 (3) OBC.
- S2. The structure has been designed incorporating the additional structural loading due to rain acting simultaneously with the snow load. The design parameters are consistent with the control flow drainage system designed by the mechanical engineer.

PROFESSIONAL SEAL APPLIED BY:

Practitioner's Name:

Firm:

Phone #:

City:

Province:

Structural Engineer's Seal

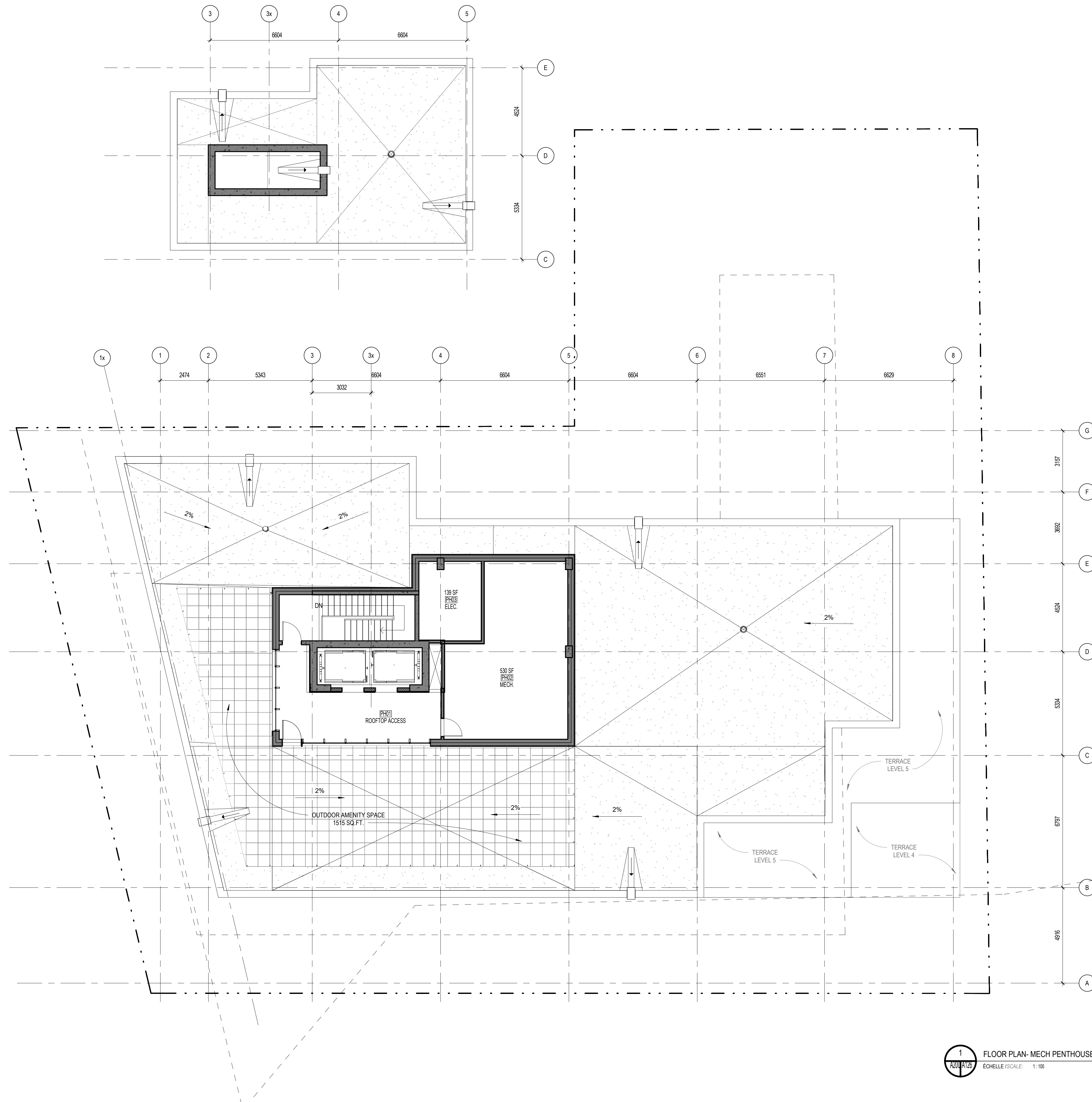

1 FLOOR PLAN- MECH PENTHOUSE
 ÉCHELLE / SCALE: 1:100

No.	Date	Événement / Object
1	2021.07.21	COORDINATION
2	2021.08.17	COORDINATION
3	2021.08.26	COORDINATION
4	2021.09.02	COORDINATION
5	2021.09.21	SITE PLAN CONTROL
6	2022.01.19	COORDINATION - 1st REVIEW

Ingenieur / Engineer
 (Mécanique & Electrique / Mechanical & Electrical)

Ingenieur / Engineer
 (Structure / Structure)

Client / Client

Architecte / Architect

Fig. 1
 3550, Saint-André St.
 Montréal QC H3C 1A6
 T. 514 861-5122

Fig. 2
 190 Somerset St W #206
 Ottawa ON K2P 0A4
 T. 613 896-4122

www.figur.ca

Droit d'auteur / Copyright

Ce dessin est sujet au droit d'auteur. Il ne peut être reproduit pour quelque intention ou usage que ce soit, à moins qu'il ne soit utilisé en accord avec l'apposition de la signature et de l'estampe originale.

This drawing is subject to copyright. It is not to be reproduced for any purpose or by any means, and may only be used if it bears an original stamp and signature.

Notes

Note:
 L'entrepreneur doit vérifier toutes les dimensions et informations sur le site et agir immédiatement l'architecte de toutes erreurs ou omissions.
 Contractor shall verify all information and dimensions on site and immediately report any errors or omissions to the architect.

Projet / Project

5-STOREY CONDO BUILDING

949 NORTH RIVER ROAD, OTTAWA

Titre / Title

ROOF PLAN

Dessiné par / Drawn by
 GCG, SC

No. projet / Project number
 2121

Vérifié par / Verified by
 MD

No. dessin / Drawing number
 6

Échelle / Scale
 1:100

Date de création du dessin / Drawing creation date
 07/07/21

A126

PRODUCT INFORMATION: TEMPEST LOW, MEDIUM FLOW (LMF) ICD

Purpose

To control the amount of storm water runoff entering a sewer system by allowing a specified flow volume out of a catch basin or manhole at a specified head. This approach conserves pipe capacity so that catch basins downstream do not become uncontrollably surcharged, which can lead to basement floods, flash floods and combined sewer overflows.

Product Description

Our LMF ICD is designed to accommodate catch basins or manholes with sewer outlet pipes 6" in diameter and larger. Any storm sewer larger than 12" may require custom modification. However, IPEX can custom build a TEMPEST device to accommodate virtually any storm sewer size.

Available in 14 preset flow curves, the LMF ICD has the ability to provide flow rates: 2lps – 17lps (31gpm – 270gpm)

Product Function

The LMF ICD vortex flow action allows the LMF ICD to provide a narrower flow curve using a larger orifice than a conventional orifice plate ICD, making it less likely to clog. When comparing flows at the same head level, the LMF ICD has the ability to restrict more flow than a conventional ICD during a rain event, preserving greater sewer capacity.

Product Construction

Constructed from durable PVC, the LMF ICD is light weight 8.9 Kg (19.7 lbs).

Product Applications

Will accommodate both square and round applications:

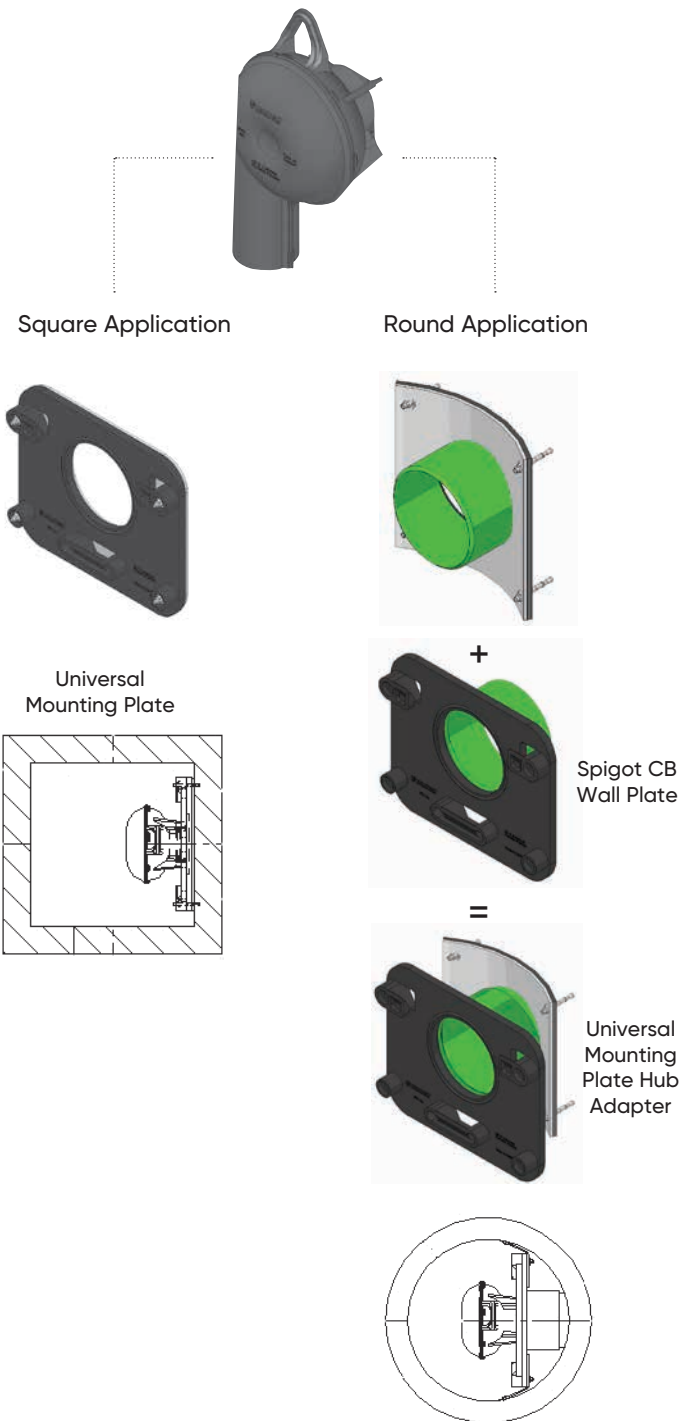
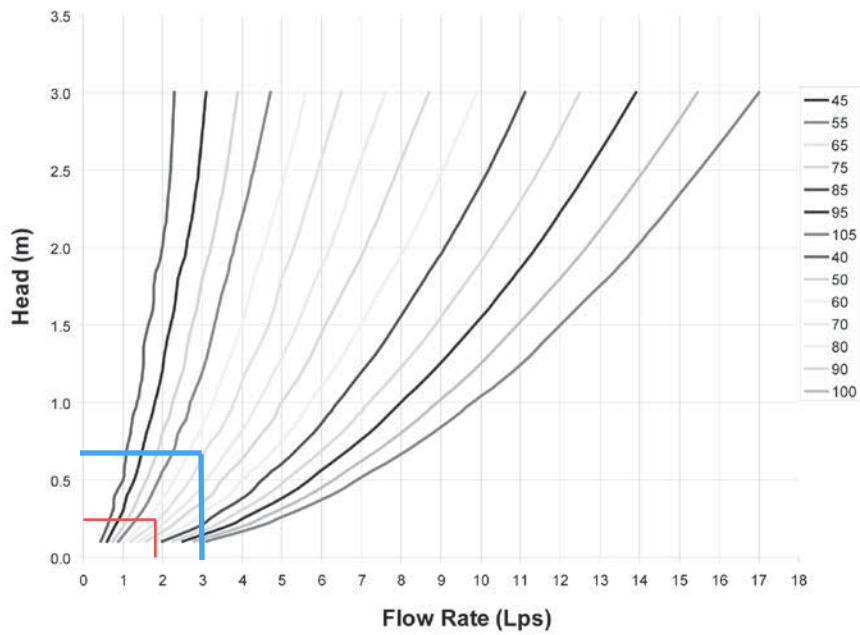
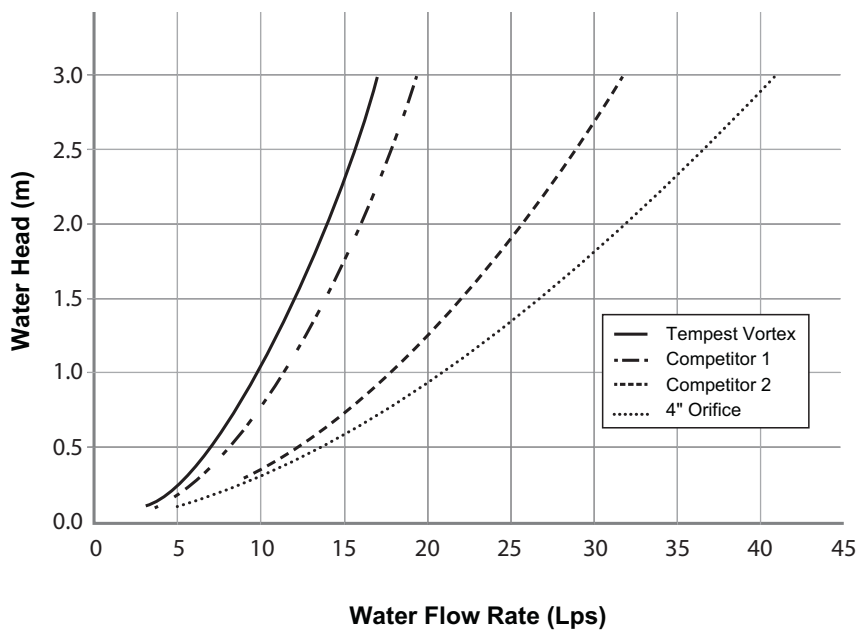

Chart 1: LMF 14 Preset Flow Curves



— 5-Year Storm
— 100-Year Storm

Chart 2: LMF Flow vs. ICD Alternatives





Falterra™ Stormwater Bioretention Filtration System

The Urban Solution for LID

The Filterra™ System

The Filterra System is similar in concept to bioretention in its function and applications but has been optimized for high volume/flow treatment and high pollutant removal. Its small footprint allows it to be used on highly developed sites such as landscaped areas, parking lots and streetscapes. Filterra is exceedingly adaptable and can be used alone or in combination with other BMPs.

Stormwater runoff enters the Filterra System through a curb-inlet opening and flows through a specially designed filter media mixture contained in a landscaped concrete container. The filter media captures and immobilizes pollutants; those pollutants are then decomposed, volatilized and incorporated into the biomass of the Filterra system's micro/macro fauna and flora. Stormwater runoff flows through the media and into an underdrain system at the bottom of the container, where the treated water is discharged.

Features and Benefits

Verified Performance. Multiple third-party field tests confirmed Filterra meets regulatory requirements with verified pollutant removal under TAPE, TARP, and NJCAT testing.

Regulatory Compliance. Third party field testing confirmed that Filterra meets state regulatory requirements for pollutant removal under TAPE and TARP testing.

Aesthetics. Landscaping enhances the appearance of your site making it more attractive while removing pollutants.

Maintenance. Maintenance is simple and safe (no confined space access), and the first year is included with the purchase of every system.

Versatile. Filterra is ideal for both new construction and urban retrofits, as well as:

- Streetscapes
- Parking lots
- Highways
- Urban settings
- Roof drains

Maintenance. Maintenance is simple and safe (no confined space access), and the first year is included with the purchase of every system.

Design Support. Our engineers can assist you with all aspects of each Filterra application, including flora selection and sizing.¹

LEED. Obtain up to 12 points for LEED Certification.

A Highly Effective System

Falterra is well-suited for the ultra-urban environment with proven high removal efficiency for many toxic substances such as petroleum and heavy metals.



Falterra™ monitoring unit at a port.

Expected Pollutant Removal

(Ranges Varying with Particle Size, Pollutant Loading and Site Conditions)

TSS Removal	85%
Phosphorus Removal	60% - 70%
Nitrogen Removal	43%
Total Copper Removal	> 58%
Dissolved Copper Removal	46%
Total Zinc Removal	> 66%
Dissolved Zinc Removal	58%
Oil & Grease	> 93%

Information on the pollutant removal efficiency of the filter soil/plant media is based on third party lab and field studies.



Maintenance is simple and safe.



Filterra™ Stormwater Bioretention Filtration System

The Urban Solution for LID

Design Assistance

Visit www.imbrium.com for details and design tools including example layouts, detail drawings, specifications, product design worksheet, and other essential design information.

Ontario Sizing Table

Filterra Size	Max Design Imp Area	
	mm	m2
1219 x 1219	350	0.035
1829 x 1524	460	0.046
2438 x 2438	1,440	0.144
3048 x 3048	2,040	0.204

NOTE: Sizing basis is using Toronto rainfall data (Station ID 0100) & continuous simulation, and Filterra's testing infiltration rate.

1. Determine Filterra locations (with effective bypass and appropriate slope < 4%) using example layout details.
2. Determine contributing drainage areas to each Filterra.
3. Choose the corresponding Filterra size from the above Sizing Table. Contact Imbrium for site specific sizing if required.
4. For best results, get us involved early in the design process. Please complete a Product Design Worksheet and include plans for placement and application review.

Proper Placement

1. Filterra should be placed on grade (not in a sump condition) with a downstream bypass structure to accommodate flows from higher intensity rainfall events.
2. To prevent scour and resuspension of collected pollutants, cross linear flow (left-to-right or right-to-left) into the Filterra throat opening is recommended. "Head-on" flow into the curb inlet is not recommended.

Cold Climate Considerations

Bioretention systems such as Filterra rely on the vegetation to assist in pollutant removal. Winter road clearing efforts can wreak havoc on roadside landscaping and stormwater structures. For the best performance, Imbrium recommends the following:

1. Use salt tolerant plants. Refer to Imbrium's recommended plant list for Filterra systems.
2. Consider using taller species for system visibility and identification during large snow events.
3. Perform maintenance at the end of winter just prior to the growing season to remove mulch contaminated with winter sands and salts. Flush system with water to wash out any remaining salt.

Filterra Placement Example



Filterra System showing curb-inlet opening.

Placement Review

Because we want your project with Filterra to be a great success, we respectfully require that each Filterra project be reviewed by Imbrium's engineering staff. This review is mandatory, as proper placement ensures you of the most efficient and cost effective solution, as well as optimum performance and minimal maintenance.



Imbrium Systems Inc.

800-565-4801 | 301-279-8827

info@imbrium.com | www.imbrium.com/filterra

©2016 Imbrium Systems Inc.



Forterra Filterra Sizing System



Standard Vault Size (mm)	Media Area (m ²)	* Treatment Flow Rate (L/s)	** Drainage Area (m ²)
1219 x 1219	1.49	1.1	350
1524 x 1828 / 1828 x 1524	2.79	2.0	480
2438 x 2438	5.94	4.2	1450
3048 x 3048	9.29	6.6	2080
* Treatment Flow Rate based on a media infiltration rate of 2539 mm/hr			
** Drainage Area based on the 90th percentile storm for a 100% impervious site in the Toronto, ON rainfall region			

Treatment Flow Rate Calculation: $(2539 \text{ mm/hr}) \times (1 \text{ hr}/3600 \text{ sec}) \times \text{Media Area (mm}^2) = (0.705 \text{ mm/s}) \times \text{Media Area (mm}^2) \times (0.001 \text{ L/mm}^2) = \text{L/s}$

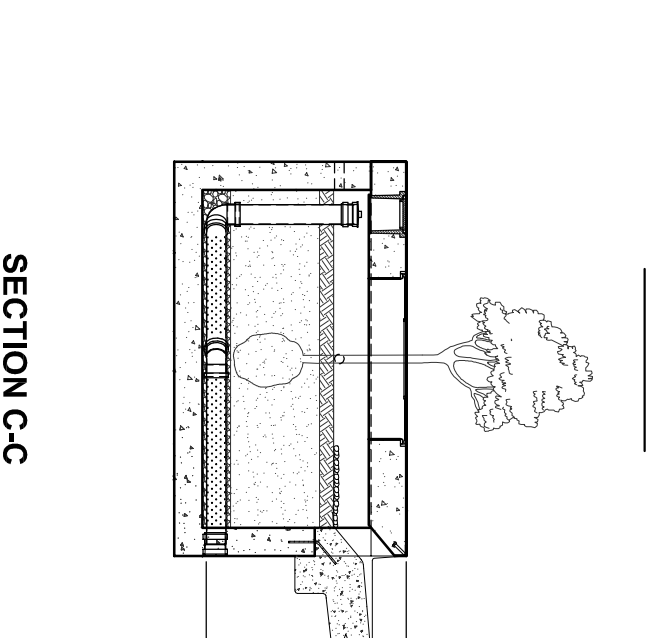
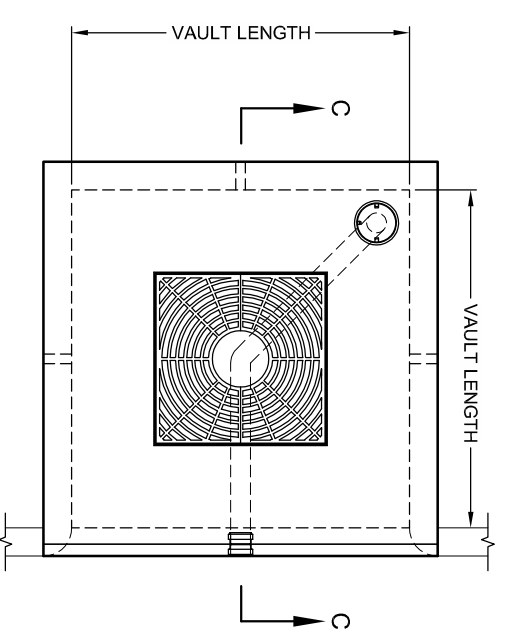
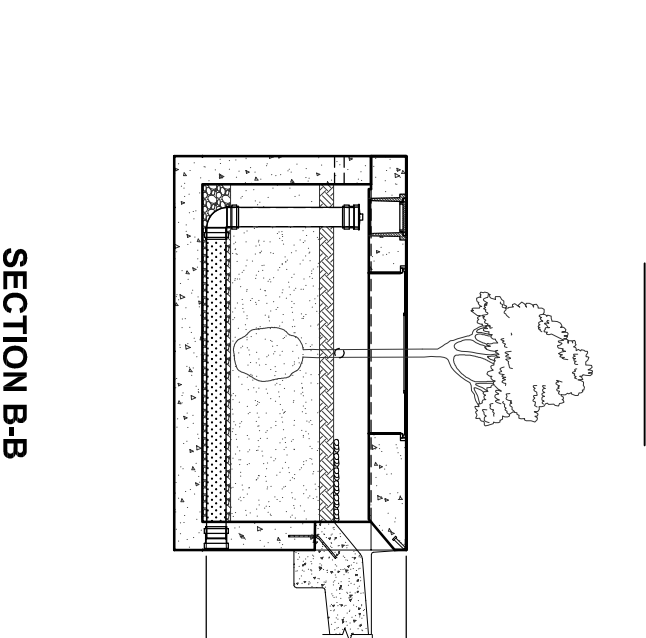
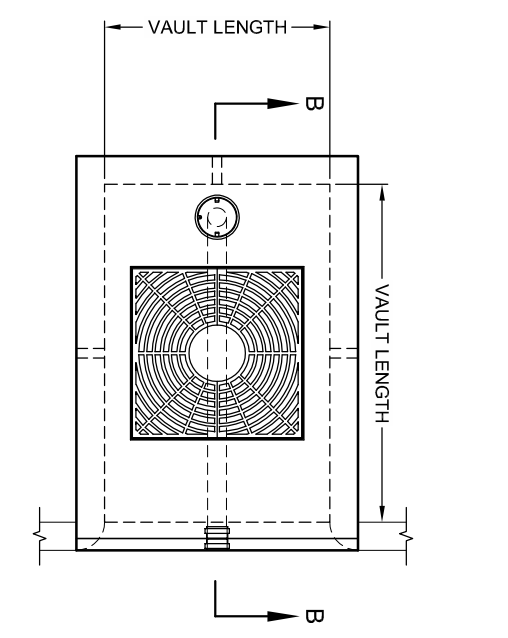
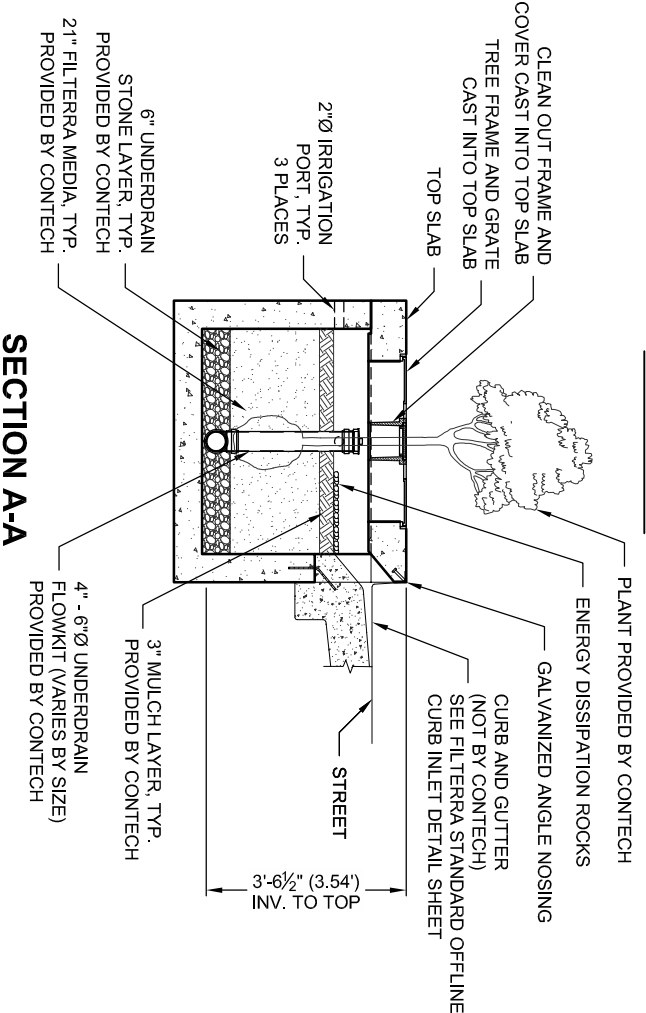
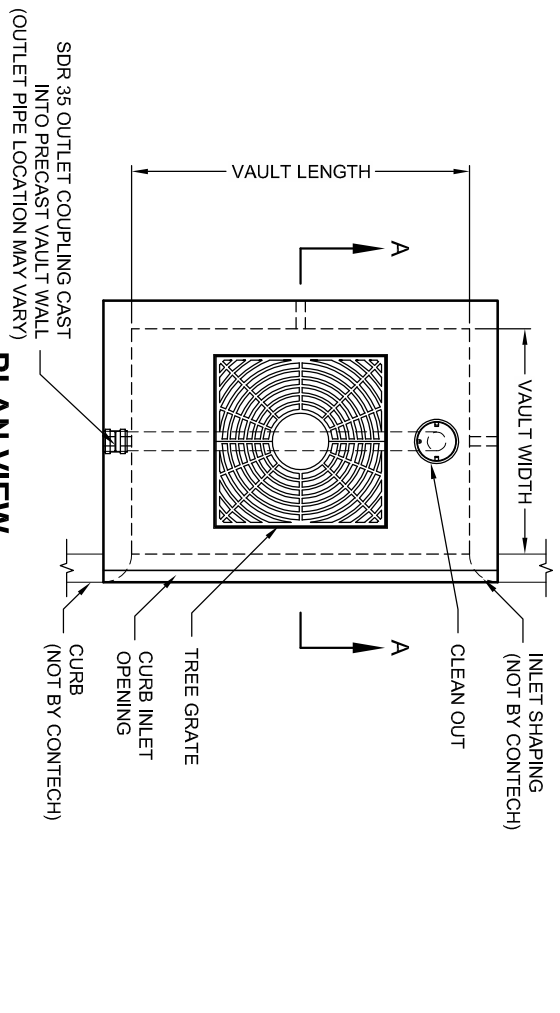

FT LONG SIDE INLET CONFIGURATION

DESIGNATION	AVAILABILITY	MEDIA BAY SIZE	VAULT SIZE (L x W)	OUTLET PIPE DIA	TREE GRATE QTY & SIZE
FT0604	N/A CA	6 x 4	6 x 4	4" SDR 35	(1) 3' x 3'
FT06504	CA ONLY	6.5 x 4	6.5 x 4	4" SDR 35	(1) 3' x 3'
FT078045	MID-ATL ONLY	7.83 x 4.5	7.83 x 4.5	4" SDR 35	(1) 3' x 3'
FT0804	N/A MID-ATL	8 x 4	8 x 4	4" SDR 35	(1) 3' x 3'
FT0806	ALL	8 x 6	8 x 6	4" SDR 35	(1) 4' x 4'
FT1006	ALL	10 x 6	10 x 6	6" SDR 35	(1) 4' x 4'
FT1206	ALL	12 x 6	12 x 6	6" SDR 35	(2) 4' x 4'
FT1307	ALL	13 x 7	13 x 7	6" SDR 35	(2) 4' x 4'
FT1408	CALL CONTECH	14 x 8	14 x 8	6" SDR 35	(2) 4' x 4'
FT1608	CALL CONTECH	16 x 8	16 x 8	6" SDR 35	(2) 4' x 4'
FT1808	CALL CONTECH	18 x 8	18 x 8	6" SDR 35	(2) 4' x 4'
FT2008	CALL CONTECH	20 x 8	20 x 8	6" SDR 35	(3) 4' x 4'
FT2208	CALL CONTECH	22 x 8	22 x 8	6" SDR 35	(3) 4' x 4'

N/A = NOT AVAILABLE

INTERNAL PIPE CONFIGURATION MAY VARY DEPENDING UPON OUTLET LOCATION.

FT SHORT SIDE INLET CONFIGURATION

DESIGNATION	AVAILABILITY	MEDIA BAY SIZE	VAULT SIZE (W x L)	OUTLET PIPE DIA	TREE GRATE QTY & SIZE
FT0406	N/A CA	4 x 6	4 x 6	4" SDR 35	(1) 3' x 3'
FT04065	CA ONLY	4 x 6.5	4 x 6.5	4" SDR 35	(1) 3' x 3'
FT0408	N/A MID-ATL	4 x 8	4 x 8	4" SDR 35	(1) 3' x 3'
FT045078	MID-ATL ONLY	4.5 x 7.83	4.5 x 7.83	4" SDR 35	(1) 3' x 3'
FT0608	ALL	6 x 8	6 x 8	4" SDR 35	(1) 4' x 4'
FT0610	ALL	6 x 10	6 x 10	6" SDR 35	(1) 4' x 4'
FT0612	ALL	6 x 12	6 x 12	6" SDR 35	(2) 4' x 4'
FT0713	ALL	7 x 13	7 x 13	6" SDR 35	(2) 4' x 4'

N/A = NOT AVAILABLE

FT SQUARE INLET CONFIGURATION

DESIGNATION	AVAILABILITY	MEDIA BAY SIZE	VAULT SIZE (W x L)	OUTLET PIPE DIA	TREE GRATE QTY & SIZE
FT0404	ALL	4 x 4	4 x 4	4" SDR 35	(1) 3' x 3'
FT0606	ALL	6 x 6	6 x 6	4" SDR 35	(1) 3' x 3'

N/A = NOT AVAILABLE



The design and information shown on this drawing is provided as a service to the project owner, engineer and contractor by Contech Engineered Solutions, LLC or one of its affiliated companies ("Contech"). Neither this drawing, nor any part thereof, may be used, reproduced or modified in any manner without the prior written consent of Contech. Failure to comply is done at the user's own risk and Contech expressly disclaims any liability or responsibility for such use. If discrepancies between the supplied information upon which the drawing is based and actual field conditions are encountered as site work progresses, these discrepancies must be reported to Contech immediately for re-evaluation of the design. Contech accepts no liability for designs based on missing, inaccurate or incomplete information supplied by others.

9025 Centre Pointe Dr., Suite 400, West Chester, OH 45069
 800-338-1122 513-645-7000 513-645-7993 FAX

FILTERRA OFFLINE (FT) CONFIGURATION DETAIL

**APPENDIX H
CITY OF OTTAWA DESIGN CHECKLIST**

City of Ottawa

4. Development Servicing Study Checklist

The following section describes the checklist of the required content of servicing studies. It is expected that the proponent will address each one of the following items for the study to be deemed complete and ready for review by City of Ottawa Infrastructure Approvals staff.

The level of required detail in the Servicing Study will increase depending on the type of application. For example, for Official Plan amendments and re-zoning applications, the main issues will be to determine the capacity requirements for the proposed change in land use and confirm this against the existing capacity constraint, and to define the solutions, phasing of works and the financing of works to address the capacity constraint. For subdivisions and site plans, the above will be required with additional detailed information supporting the servicing within the development boundary.

4.1 General Content

Criteria	Location (if applicable)
<input type="checkbox"/> Executive Summary (for larger reports only).	N/A
<input type="checkbox"/> Date and revision number of the report.	On Cover
<input type="checkbox"/> Location map and plan showing municipal address, boundary, and layout of proposed development.	Appendix A
<input type="checkbox"/> Plan showing the site and location of all existing services.	Site Servicing Plan (C101)
<input type="checkbox"/> Development statistics, land use, density, adherence to zoning and official plan, and reference to applicable subwatershed and watershed plans that provide context to which individual developments must adhere.	1.1 Purpose 1.2 Site Description 6.0 Stormwater Management
<input type="checkbox"/> Summary of pre-consultation meetings with City and other approval agencies.	Appendix B
<input type="checkbox"/> Reference and confirm conformance to higher level studies and reports (Master Servicing Studies, Environmental Assessments, Community Design Plans), or in the case where it is not in conformance, the proponent must provide justification and develop a defensible design criteria.	1.1 Purpose 1.2 Site Description 6.0 Stormwater Management
<input type="checkbox"/> Statement of objectives and servicing criteria.	3.0 Pre-Consultation Summary

<input type="checkbox"/> Identification of existing and proposed infrastructure available in the immediate area.	N/A
<input type="checkbox"/> Identification of Environmentally Significant Areas, watercourses and Municipal Drains potentially impacted by the proposed development (Reference can be made to the Natural Heritage Studies, if available).	Site Grading, Drainage, Sediment & Erosion Control Plan (C101)
<input type="checkbox"/> Concept level master grading plan to confirm existing and proposed grades in the development. This is required to confirm the feasibility of proposed stormwater management and drainage, soil removal and fill constraints, and potential impacts to neighbouring properties. This is also required to confirm that the proposed grading will not impede existing major system flow paths.	Site Grading, Drainage, Sediment & Erosion Control Plan (C101)
<input type="checkbox"/> Identification of potential impacts of proposed piped services on private services (such as wells and septic fields on adjacent lands) and mitigation required to address potential impacts.	N/A
<input type="checkbox"/> Proposed phasing of the development, if applicable.	N/A
<input type="checkbox"/> Reference to geotechnical studies and recommendations concerning servicing.	Section 2.0 Background Studies, Standards and References
<input type="checkbox"/> All preliminary and formal site plan submissions should have the following information: <ul style="list-style-type: none"> ○ Metric scale ○ North arrow (including construction North) ○ Key plan ○ Name and contact information of applicant and property owner ○ Property limits including bearings and dimensions ○ Existing and proposed structures and parking areas ○ Easements, road widening and rights-of-way ○ Adjacent street names 	Site Grading, Drainage, Sediment & Erosion Control Plan (C101)

4.2 Development Servicing Report: Water

Criteria	Location (if applicable)
<input type="checkbox"/> Confirm consistency with Master Servicing Study, if available	N/A
<input type="checkbox"/> Availability of public infrastructure to service proposed development	N/A
<input type="checkbox"/> Identification of system constraints	N/A
<input type="checkbox"/> Identify boundary conditions	Appendix C
<input type="checkbox"/> Confirmation of adequate domestic supply and pressure	N/A
<input type="checkbox"/> Confirmation of adequate fire flow protection and confirmation that fire flow is calculated as per the Fire Underwriter's Survey. Output should show available fire flow at locations throughout the development.	Appendix C
<input type="checkbox"/> Provide a check of high pressures. If pressure is found to be high, an assessment is required to confirm the application of pressure reducing valves.	N/A
<input type="checkbox"/> Definition of phasing constraints. Hydraulic modeling is required to confirm servicing for all defined phases of the project including the ultimate design	N/A
<input type="checkbox"/> Address reliability requirements such as appropriate location of shut-off valves	N/A
<input type="checkbox"/> Check on the necessity of a pressure zone boundary modification.	N/A
<input type="checkbox"/> Reference to water supply analysis to show that major infrastructure is capable of delivering sufficient water for the proposed land use. This includes data that shows that the expected demands under average day, peak hour and fire flow conditions provide water within the required pressure range	Appendix C

<input type="checkbox"/> Description of the proposed water distribution network, including locations of proposed connections to the existing system, provisions for necessary looping, and appurtenances (valves, pressure reducing valves, valve chambers, and fire hydrants) including special metering provisions.	Site Servicing Plan (C101)
<input type="checkbox"/> Description of off-site required feeder mains, booster pumping stations, and other water infrastructure that will be ultimately required to service proposed development, including financing, interim facilities, and timing of implementation.	N/A
<input type="checkbox"/> Confirmation that water demands are calculated based on the City of Ottawa Design Guidelines.	Appendix C
<input type="checkbox"/> Provision of a model schematic showing the boundary conditions locations, streets, parcels, and building locations for reference.	N/A

4.3 Development Servicing Report: Wastewater

Criteria	Location (if applicable)
<input type="checkbox"/> Summary of proposed design criteria (Note: Wet-weather flow criteria should not deviate from the City of Ottawa Sewer Design Guidelines. Monitored flow data from relatively new infrastructure cannot be used to justify capacity requirements for proposed infrastructure).	N/A
<input type="checkbox"/> Confirm consistency with Master Servicing Study and/or justifications for deviations.	N/A
<input type="checkbox"/> Consideration of local conditions that may contribute to extraneous flows that are higher than the recommended flows in the guidelines. This includes groundwater and soil conditions, and age and condition of sewers.	N/A
<input type="checkbox"/> Description of existing sanitary sewer available for discharge of wastewater from proposed development.	Section 5.2 Proposed Sanitary Sewer

<input type="checkbox"/> Verify available capacity in downstream sanitary sewer and/or identification of upgrades necessary to service the proposed development. (Reference can be made to previously completed Master Servicing Study if applicable)	Section 5.3 Proposed Sanitary Design
<input type="checkbox"/> Calculations related to dry-weather and wet-weather flow rates from the development in standard MOE sanitary sewer design table (Appendix 'C') format.	N/A
<input type="checkbox"/> Description of proposed sewer network including sewers, pumping stations, and forcemains.	Section 5.2 Proposed Sanitary Sewer
<input type="checkbox"/> Discussion of previously identified environmental constraints and impact on servicing (environmental constraints are related to limitations imposed on the development in order to preserve the physical condition of watercourses, vegetation, soil cover, as well as protecting against water quantity and quality).	N/A
<input type="checkbox"/> Pumping stations: impacts of proposed development on existing pumping stations or requirements for new pumping station to service development.	N/A
<input type="checkbox"/> Forcemain capacity in terms of operational redundancy, surge pressure and maximum flow velocity.	N/A
<input type="checkbox"/> Identification and implementation of the emergency overflow from sanitary pumping stations in relation to the hydraulic grade line to protect against basement flooding.	N/A
<input type="checkbox"/> Special considerations such as contamination, corrosive environment etc.	N/A

4.4 Development Servicing Report: Stormwater Checklist

Criteria	Location (if applicable)
<input type="checkbox"/> Description of drainage outlets and downstream constraints including legality of outlets (i.e. municipal drain, right-of-way, watercourse, or private property)	Section 6.0 Stormwater Sewer Design & Section 7.0 Proposed Stormwater Management
<input type="checkbox"/> Analysis of available capacity in existing public infrastructure.	N/A
<input type="checkbox"/> A drawing showing the subject lands, its surroundings, the receiving watercourse, existing drainage patterns, and proposed drainage pattern.	Pre & Post-Development Plans
<input type="checkbox"/> Water quantity control objective (e.g. controlling post-development peak flows to pre-development level for storm events ranging from the 2 or 5-year event (dependent on the receiving sewer design) to 100-year return period); if other objectives are being applied, a rationale must be included with reference to hydrologic analyses of the potentially affected subwatersheds, taking into account long-term cumulative effects.	Section 6.0 Stormwater Sewer Design & Section 7.0 Proposed Stormwater Management
<input type="checkbox"/> Water Quality control objective (basic, normal or enhanced level of protection based on the sensitivities of the receiving watercourse) and storage requirements.	Section 6.0 Stormwater Sewer Design & Section 7.0 Proposed Stormwater Management
<input type="checkbox"/> Description of the stormwater management concept with facility locations and descriptions with references and supporting information.	Section 6.0 Stormwater Sewer Design & Section 7.0 Proposed Stormwater Management
<input type="checkbox"/> Set-back from private sewage disposal systems.	N/A
<input type="checkbox"/> Watercourse and hazard lands setbacks.	N/A
<input type="checkbox"/> Record of pre-consultation with the Ontario Ministry of Environment and the Conservation Authority that has jurisdiction on the affected watershed.	N/A
<input type="checkbox"/> Confirm consistency with sub-watershed and Master Servicing Study, if applicable study exists.	N/A
<input type="checkbox"/> Storage requirements (complete with calculations) and conveyance capacity for minor events (1:5-year return period) and major events (1:100-year return period).	Appendix G

<input type="checkbox"/> Identification of watercourses within the proposed development and how watercourses will be protected, or, if necessary, altered by the proposed development with applicable approvals.	Site Grading, Drainage, Sediment & Erosion Control Plan
<input type="checkbox"/> Calculate pre-and post development peak flow rates including a description of existing site conditions and proposed impervious areas and drainage catchments in comparison to existing conditions.	Section 7.0 Proposed Stormwater Management Appendix G
<input type="checkbox"/> Any proposed diversion of drainage catchment areas from one outlet to another.	Section 6.0 Stormwater Sewer Design & Section 7.0 Proposed Stormwater Management
<input type="checkbox"/> Proposed minor and major systems including locations and sizes of stormwater trunk sewers, and stormwater management facilities.	Section 6.0 Stormwater Sewer Design & Section 7.0 Proposed Stormwater Management
<input type="checkbox"/> If quantity control is not proposed, demonstration that downstream system has adequate capacity for the post-development flows up to and including the 100-year return period storm event.	N/A
<input type="checkbox"/> Identification of potential impacts to receiving watercourses	N/A
<input type="checkbox"/> Identification of municipal drains and related approval requirements.	N/A
<input type="checkbox"/> Descriptions of how the conveyance and storage capacity will be achieved for the development.	Section 6.0 Stormwater Sewer Design & Section 7.0 Proposed Stormwater Management
<input type="checkbox"/> 100-year flood levels and major flow routing to protect proposed development from flooding for establishing minimum building elevations (MBE) and overall grading.	Site Grading, Drainage, Sediment & Erosion Control Plan (C101)
<input type="checkbox"/> Inclusion of hydraulic analysis including hydraulic grade line elevations.	N/A

<input type="checkbox"/> Description of approach to erosion and sediment control during construction for the protection of receiving watercourse or drainage corridors.	Section 8.0 Sediment & Erosion Control
<input type="checkbox"/> Identification of floodplains – proponent to obtain relevant floodplain information from the appropriate Conservation Authority. The proponent may be required to delineate floodplain elevations to the satisfaction of the Conservation Authority if such information is not available or if information does not match current conditions.	N/A
<input type="checkbox"/> Identification of fill constraints related to floodplain and geotechnical investigation.	N/A

4.5 Approval and Permit Requirements: Checklist

The Servicing Study shall provide a list of applicable permits and regulatory approvals necessary for the proposed development as well as the relevant issues affecting each approval. The approval and permitting shall include but not be limited to the following:

Criteria	Location (if applicable)
<input type="checkbox"/> Conservation Authority as the designated approval agency for modification of floodplain, potential impact on fish habitat, proposed works in or adjacent to a watercourse, cut/fill permits and Approval under Lakes and Rivers Improvement Act. The Conservation Authority is not the approval authority for the Lakes and Rivers Improvement Act. Where there are Conservation Authority regulations in place, approval under the Lakes and Rivers Improvement Act is not required, except in cases of dams as defined in the Act.	N/A
<input type="checkbox"/> Application for Certificate of Approval (CofA) under the Ontario Water Resources Act.	N/A
<input type="checkbox"/> Changes to Municipal Drains.	N/A
<input type="checkbox"/> Other permits (National Capital Commission, Parks Canada, Public Works and Government Services Canada, Ministry of Transportation etc.)	N/A

4.6 Conclusion Checklist

Criteria	Location (if applicable)
<input type="checkbox"/> Clearly stated conclusions and recommendations	Section 9.0 Summary Section 10.0 Recommendations
<input type="checkbox"/> Comments received from review agencies including the City of Ottawa and information on how the comments were addressed. Final sign-off from the responsible reviewing agency.	All are stamped
<input type="checkbox"/> All draft and final reports shall be signed and stamped by a professional Engineer registered in Ontario	All are stamped