

Engineering

- Land/Site Development
- Municipal Infrastructure
- Environmental/Water Resources
- Traffic/Transportation
- Recreational

Planning

- Land/Site Development
- Planning Application Management
- Municipal Planning
- Urban Design
- Expert Witness (OLT)
- Wireless Industry

Landscape Architecture

- Streetscapes & Public Amenities
- Open Space, Parks & Recreation
- Community & Residential
- Commercial & Institutional
- Environmental Restoration

Proposed Residential Development 1500 Merivale Road

Serviceability and Stormwater Management Report

September 27, 2024

City of Ottawa
Planning, Infrastructure and Economic Development Department
Planning and Infrastructure Approvals Branch
110 Laurier Avenue West, 4th Floor
Ottawa ON, K1P 1J1

Attention: Lisa Stern, Planner

Dear Sir:

**Reference: 1500 Merivale Road - Claridge Development
Serviceability and Stormwater Master Plan**

Please find enclosed the 'Servicing Report' for the above noted project. This report is submitted in support of the site plan application and outlines how the site will be serviced with public infrastructure.

Should you have any questions or require additional information, please contact the undersigned.

Yours truly,

NOVATECH



Greg MacDonald, P. Eng.
Director, Land Development and Public Sector Infrastructure

cc: Vincent, Denomme, Claridge Homes

September 11, 2024

City of Ottawa
Planning, Infrastructure and Economic Development Department
Planning and Infrastructure Approvals Branch
110 Laurier Avenue West, 4th Floor
Ottawa ON, K1P 1J1

Attention: Lisa Stern, Planner

Dear Sir:

**Reference: 1500 Merivale Road - Claridge Development
Serviceability and Stormwater Master Plan**

Please find enclosed the 'Servicing Report' for the above noted project. This report is submitted in support of the site plan application and outlines how the site will be serviced with public infrastructure.

Should you have any questions or require additional information, please contact the undersigned.

Yours truly,

NOVATECH



Greg MacDonald, P. Eng.
Director, Land Development and Public Sector Infrastructure

cc: Vincent, Denomme, Claridge Homes

TABLE OF CONTENTS

1.0 INTRODUCTION	1
1.1 Existing Conditions.....	1
1.2 Proposed Development.....	1
2.0 SITE CONSTRAINTS	2
3.0 SANITARY SEWER	3
3.1 Design Criteria	4
3.2 Merivale System (Phase 1)	4
3.3 Baseline System (Phase 4-6).....	4
3.4 Clyde/ Merivale System (Phases, 2-3 & 7-11).....	5
4.0 STORM SERVICING	5
4.1 Stormwater Management Criteria.....	6
4.1.1 <i>Minor System (Storm Sewers)</i>	6
4.1.2 <i>Major System</i>	6
4.1.3 <i>Water Quality Control</i>	6
4.2 Storm Sewer Design (Minor System)	7
4.2.1 <i>Allowable Release Rates</i>	7
4.2.2 <i>Orifice Controls</i>	8
4.2.3 <i>Water Quality Controls</i>	8
4.3 On-Site Storage	8
4.3.1 <i>Overland Flow and Surface Storage (Major System)</i>	8
4.3.2 <i>Underground Storage</i>	8
4.4 Hydrologic & Hydraulic Modeling.....	9
4.4.1 <i>Design Storms</i>	9
4.4.2 <i>Model Development</i>	9
4.4.3 <i>Storm Drainage Areas</i>	10
4.5 Minor System Design and Analysis	12
4.5.1 <i>Orifice Controls</i>	12
4.5.2 <i>Allowable Release Rate – Parkwood Hills</i>	13
4.5.3 <i>Peak Flows</i>	14
4.5.4 <i>Hydraulic Grade Line</i>	15
4.5.5 <i>Underground Storage Volumes</i>	16
4.6 Major System Design and Analysis	16
5.0 WATERMAIN	17
5.1 Ultimate Build-out.....	19
5.1.1 <i>Merivale System</i>	19
5.1.2 <i>Baseline System</i>	20
6.0 EROSION AND SEDIMENT CONTROL	21
7.0 CONCLUSIONS AND RECOMMENDATIONS	22
8.0 CLOSURE	23

List of Figures

Figure 1	Key Plan
Figure 2	Existing Conditions
Figure 3	Site Plan
Figure 4	Phasing Plan
Figure 5	Existing Stormwater Management Plan
Figure 6	Pressure Zone Plan

Tables

Table 4.1: Storm Sewer Design Parameters	7
Table 4.2: Pinecrest Creek Allowable Release Rates.....	7
Table 4.3: Hydrologic Modeling Parameters.....	11
Table 4.4: Orifice Parameters	13
Table 4.5: Per Phase Allowable Release Rates	14
Table 4.6: Peak Flows.....	14
Table 4.7: Storm Sewer Hydraulic Grade Line	15
Table 4.8: Storage Required	16
Table 4.9: Ponding Depths at Catchbasins (100yr Event)	16
Table 5.1: Merivale Road Domestic Water Demand Summary.....	17
Table 5.2 Baseline Road Domestic Water Demand Summary	18
Table 5.3: Merivale Road Domestic Water Demand Summary.....	18
Table 5.4: Water Boundary Conditions.....	18
Table 5.4: Water Analysis Summary	19
Table 5.5: Water Boundary Conditions and Hydraulic Analysis Summary	20

Appendices

Appendix A Pre - Consultation Meeting Minutes.....	1
Appendix B Sanitary Servicing	2
Appendix C Storm Servicing.....	3
Appendix D Stormwater Management.....	4
Appendix E Water Servicing.....	5
Appendix F Servicing Study Guidelines Checklist	6

List of Drawings

Notes and Details General Servicing	121009-NDGP
Notes and Details Grading.....	121009-NDGR
Erosion and Sediment Control Plan.....	121009-ESC
General Plan of Services (East).....	121009-GP2
General Plan of Services (West).....	121009-GP3
Grading Plan (East).....	121009-GR2
Grading Plan (West).....	121009-GR3
Plan & Profile Street 1 1+000.00 - 1+324.77.....	121009-PR1
Plan & Profile Clyde Sanitary Connection 2+000.00-2+166.93.....	121009-PR2
Plan & Profile Private Road 2+000.00 - 2+260.27.....	121009-PR3
Stormwater Management Plan	121009-SWM
Sanitary Drainage Area Plan	121009-SAN

1.0 INTRODUCTION

Novatech has been retained by Claridge Homes to prepare a Serviceability and Stormwater Management Report for the proposed development located at 1500 Merivale Road within the City of Ottawa. The proposed site is denoted as Part of Lots 18,19, 20, and 21, Registered Plan 30, City of Ottawa. This report is prepared as a master Servicing and Stormwater Master plan for the subject lands. **Figure 1** Key Plan shows the site location.

1.1 Existing Conditions

The subject site has an approximate area of 6.06 hectares (ha). Presently the site contains a Midas auto shop, and a restaurant named Green Papaya fronting Baseline Road. Fronting Merivale Road the site contains the existing Kimway Crescent, and remnants of various commercial buildings that have since been demolished. Due to the previous developments, there are various concrete and asphalt rubble piles throughout the site, along with abandoned building foundations and services. Towards the north property line behind the existing commercial buildings fronting Baseline Road, there is an undeveloped area of approximately 1.0ha containing trees and shrubs. The site has a grade variance of approximately 7.7m (102.00 – 94.30m) from Baseline Road to Merivale Road. The site drains primarily from the north-west to the south-east.

The site is bound by an existing Tim Hortons, and Baseline Road to the north, existing retail (Loblaws, Dollar Tree, Starbucks) to the east, Astral Media Radio Gp Ottawa, Hi Fresh Foods, The Sea Food Grill, and Merivale Road to the south, and Existing Commercial (Suya Joint/ African Grill, Frisby Tire Co, and Motor Sports World), existing asphalt parking and Clyde Avenue to the west. The existing asphalt parking area to the west near the intersection of Clyde and Baseline Road is currently planned to be developed with a Dymon storage facility and has an active City of Ottawa development number of D07-12-17-0131. **Figure 2** shows the existing site conditions.

1.2 Proposed Development

The subject site is designated as 'General Urban Area' on Schedule B of the City of Ottawa's Official Plan, with frontage onto Baseline Road, Clyde Avenue, and Merivale Road, all of which have an Arterial Mainstreet designation. The property is zoned 'Arterial Mainstreet' (AM10[2217] H(34)).

The proposed development will include a public road, a private road, a public parkette, and 11 apartment buildings ranging in 6-11 storeys in height. The proposed development will be constructed in numerous phases over the span of 15 years. The proposed apartment buildings will be complete with underground parking structures with five (5) entrances from the various phases. The site will include a proposed local public roadway (currently named Street 1) which will interconnect Merivale Road and Baseline Road, and a proposed Private Road which will have access from the proposed Street 1 and Merivale Road. The proposed Street 1 will provide direct access to Phases 1-5 and the public parkette, while phases 6-11 will be accessed from the proposed private roadway. For pedestrian circulation a multi-use pathway is proposed within the Street 1 right-of-way which will provide pedestrian circulation between Baseline Road and Merivale Road. Refer to **Figure 3: Site Plan** for details.

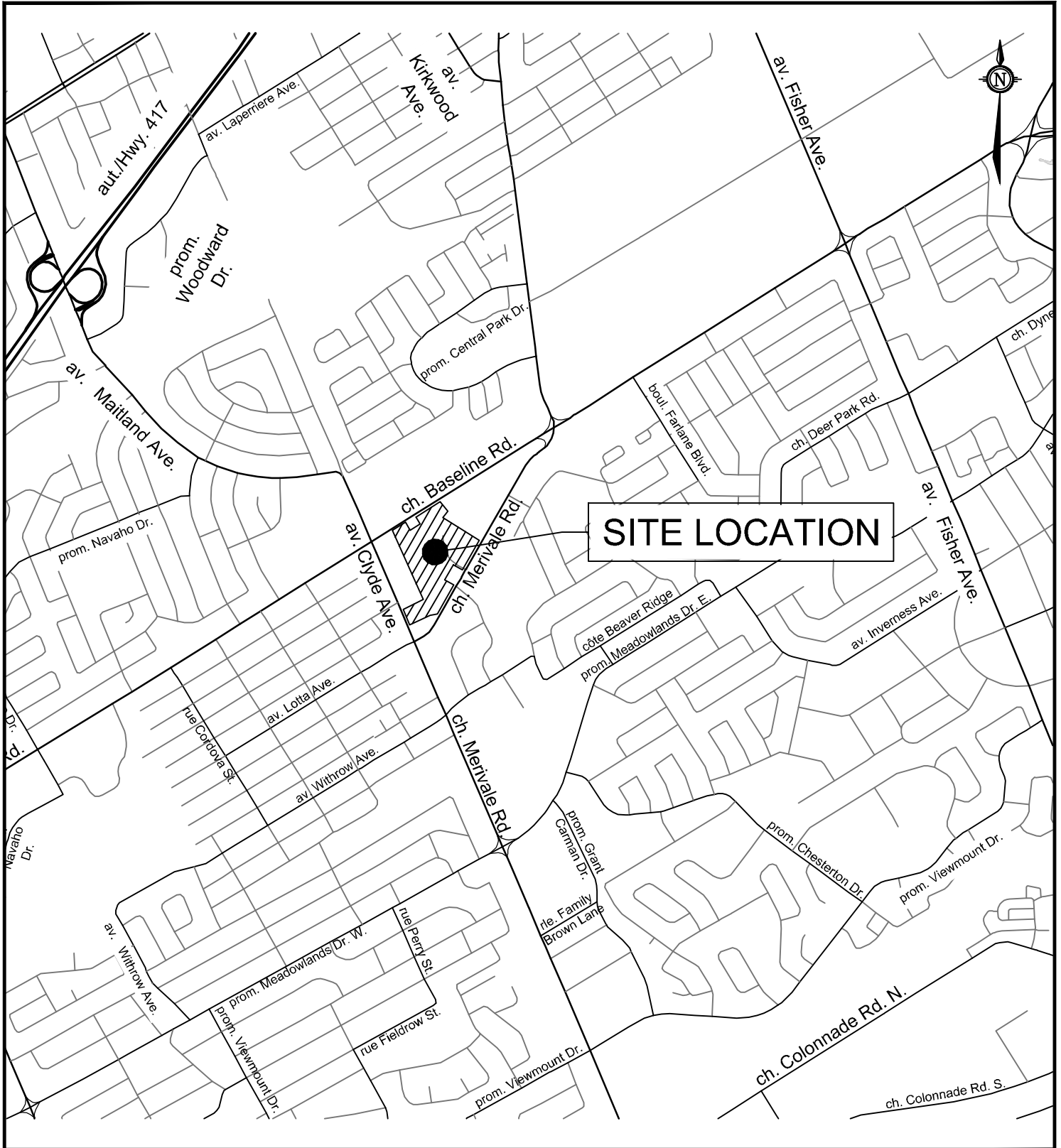

SITE LOCATION

M:\2021\121009\CAD\Design\121009-KP.dwg, KP, Dec 02, 2022 - 3:07pm, rgood



Engineers, Planners & Landscape Architects
 Suite 200, 240 Michael Cowpland Drive
 Ottawa, Ontario, Canada K2M 1P6

Telephone (613) 254-9643
 Facsimile (613) 254-5867
 Website www.novatech-eng.com

CITY OF OTTAWA
 1500 MERIVALE RD

KEYPLAN

SCALE

N.T.S

DATE

DEC 2022

JOB

121009

FIGURE

FIGURE-1

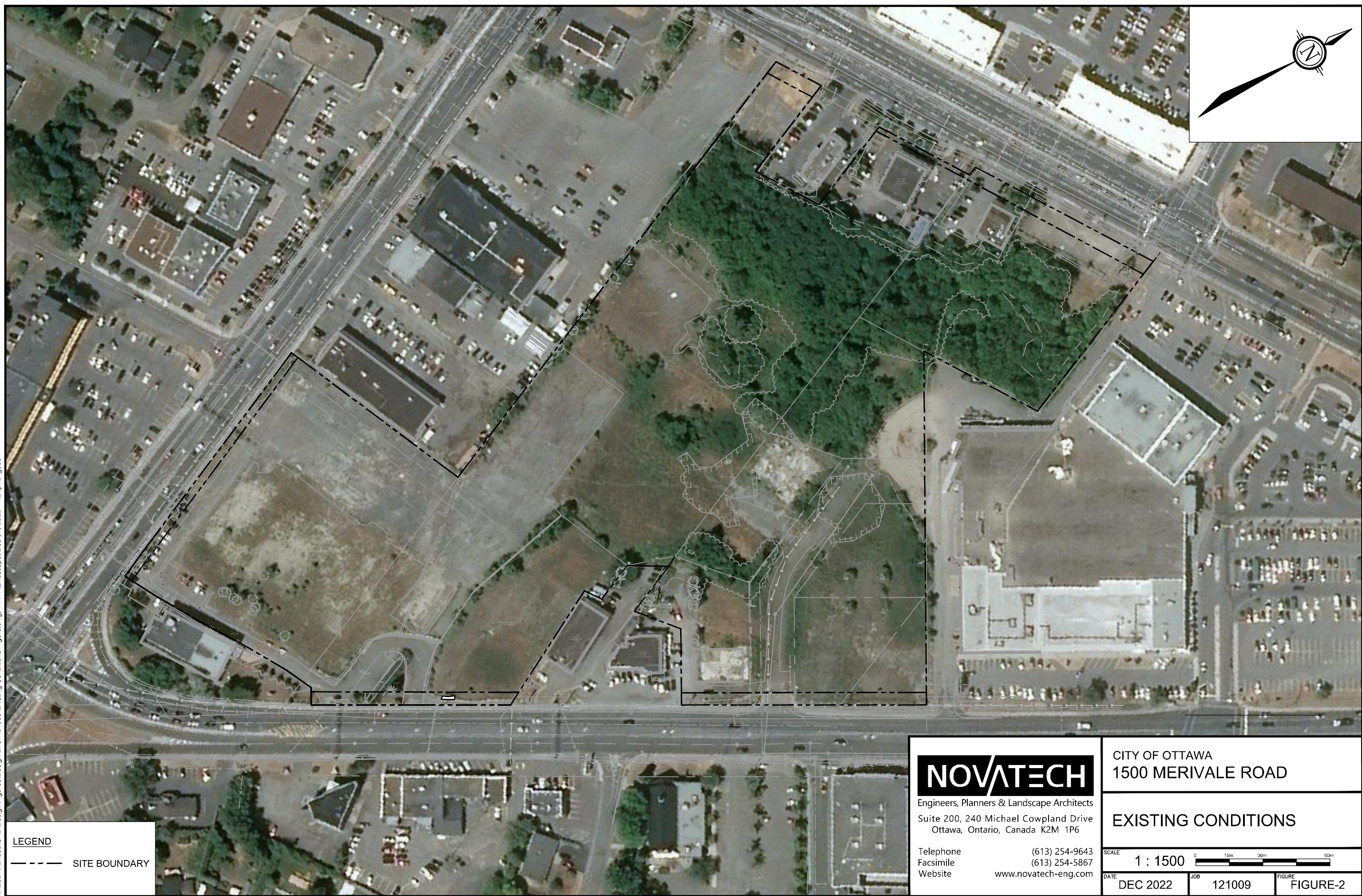
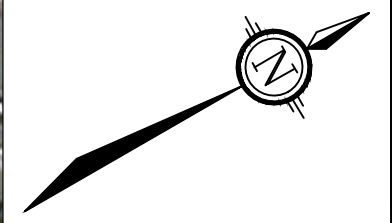

LEGEND
 - - - - - SITE BOUNDARY

NOVATECH

Engineers, Planners & Landscape Architects
 Suite 200, 240 Michael Cowpland Drive
 Ottawa, Ontario, Canada K2M 1P6

Telephone (613) 254-9643
 Facsimile (613) 254-5867
 Website www.novatech-eng.com

CITY OF OTTAWA
 1500 MERIVALE ROAD

EXISTING CONDITIONS

SCALE 1 : 1500
 0 15m 30m 60m

DATE	JOB	FIGURE
DEC 2022	121009	FIGURE-2

M:\2021\121009\CAD\Design\Figures\Design Brief\121009-Existing Conditions Figure.dwg, 11x17 landscape, Dec 01, 2022 - 4:21pm, rgood

A summary of the 11 development phases are provided below:

- Phase 1:
 - 10-storeys with 118 dwellings, and approx. 153m² of commercial;
- Phase 2:
 - 9-storeys with 276 dwellings, and approx. 136.26 m² of commercial;
- Phase 3:
 - 11-storeys with 67 dwellings;
- Phase 4:
 - 9-storeys with 227 dwellings, and approx. 118m² of commercial;
- Phase 5:
 - 9-storeys with a total of 257 dwellings, and approx. 102 m² of commercial;
- Phase 6:
 - 9-storeys with 196 dwellings, and approx. 57 m² of commercial;
- Phase 7:
 - 9-storeys with 162 dwellings;
- Phase 8:
 - 9-storeys with 198 dwellings;
- Phase 9:
 - 9-storeys with 212 dwellings, and approx. 156 m² of commercial;
- Phase 10:
 - 11-storeys with 287 dwellings and approx. 412 m² of commercial;
- Phase 11:
 - 6-storeys with 85 dwellings and approx. 170 m² of commercial;

In total, the proposed development will consist of 2088 apartment dwellings and approximately 1320 m² of commercial space. The entire site will include parking spaces for residents and visitors. Phase 1 of the proposed development is anticipated to be built out by 2027. The ultimate buildout year of the development is anticipated to be in 2038. Refer to **Figure 4: Phasing Plan** for details.

2.0 SITE CONSTRAINTS

A geotechnical investigation was completed by Paterson Group Inc. and a report prepared entitled 'Geotechnical Investigation, Proposed Multi-Storey Building Complex, 1500 Merivale Road' dated February 23, 2021. The report included the following findings:

- Generally, the subsurface profile across the site consists of an approximate 0.8 to 2.6 m thickness of fill underlain by bedrock.
- the long-term groundwater table can be expected at approximate depths of 2.5 to 3.5 m below the existing ground surface. However, it should be noted that groundwater levels are subject to seasonal fluctuations. Therefore, the groundwater level could vary at the time of construction.
- Existing foundation walls and other construction debris should be entirely removed from within the perimeters of the proposed buildings. Under paved areas, existing

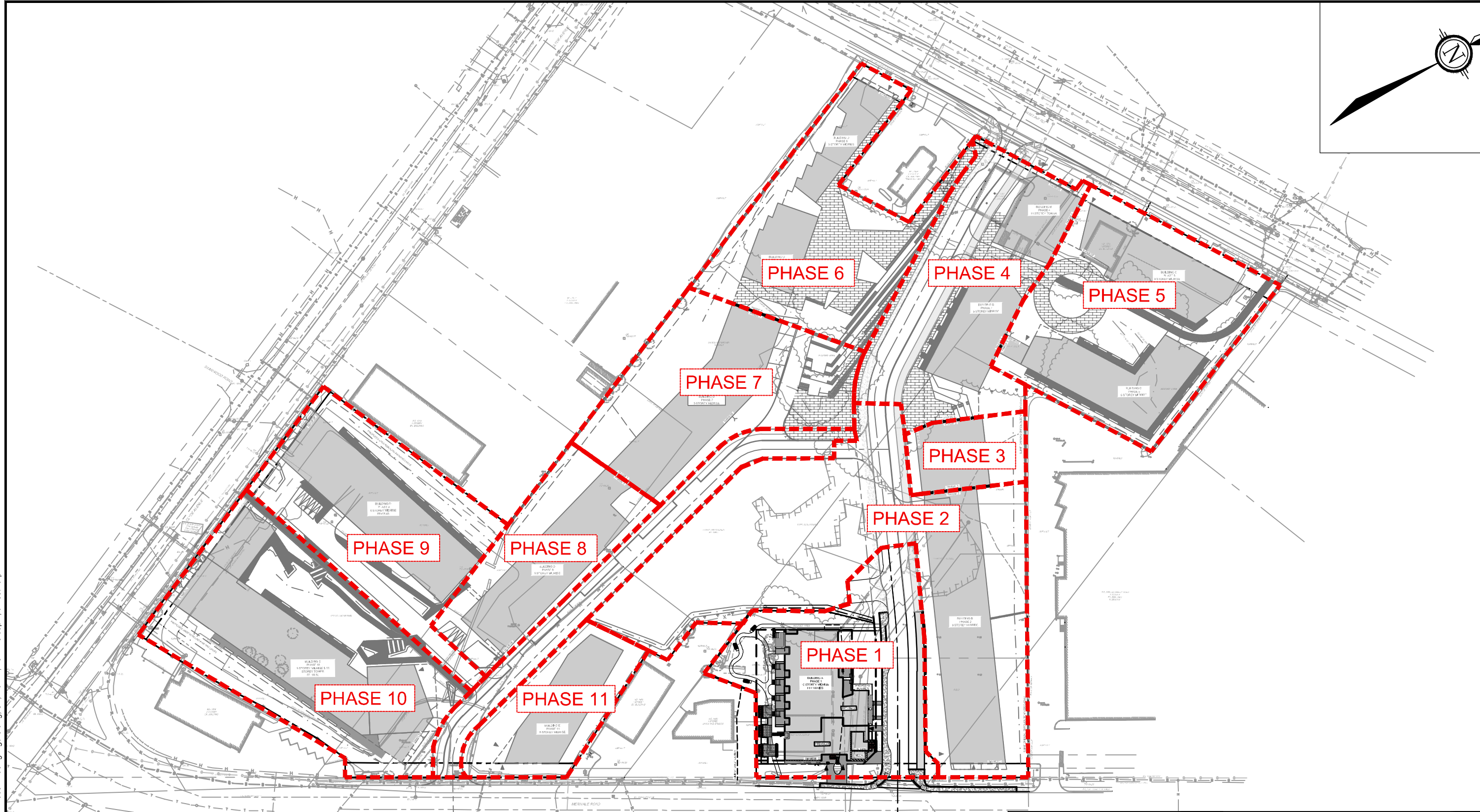
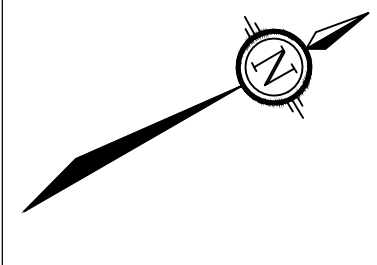

LEGEND

 PHASING OUTLINE

NOVATECH

Engineers, Planners & Landscape Architects
Suite 200, 240 Michael Cowpland Drive
Ottawa, Ontario, Canada K2M 1P6

Telephone (613) 254-9643
Facsimile (613) 254-5867
Website www.novatech-eng.com

CITY OF OTTAWA
1500 MERIVALE ROAD

PHASING PLAN

SCALE 1 : 1500 

DATE JULY 2024 JOB 121009 FIGURE FIGURE-4

M:\2021\121009\CAD\Design\Figures\Design Brief\121009-Phasing Figure.dwg, SP, Mar 21, 2024 - 5:59pm, amestiwarp

construction remnants, such as foundation walls, should be excavated to a minimum of 1 m below final grade.

- The excavation side slopes above the groundwater level extending to a maximum depth of 3 m should be excavated at 1H:1V or shallower. The shallower slope is required for excavation below groundwater level. The subsurface soils are considered to be a Type 2 and 3 soil according to the Occupational Health and Safety Act and Regulations for Construction Projects.0
- A temporary Ministry of Environment, Conservation and Parks (MECP) permit to take water (PTTW) may be required if more than 400,000 L/day of ground and/or surface water are to be pumped during the construction phase. At least 4 to 5 months should be allowed for completion of the application and issuance of the permit by the MECP.
- For typical ground or surface water volumes being pumped during the construction phase, typically between 50,000 to 400,000 L/day, it is required to register on the Environmental Activity and Sector Registry (EASR). A minimum of two to four weeks should be allotted for completion of the EASR registration and the Water Taking and Discharge Plan to be prepared by a Qualified Person as stipulated under O.Reg. 63/16. If a project qualifies for a PTTW based upon anticipated conditions, an EASR will not be allowed as a temporary dewatering measure while awaiting the MECP review of the PTTW application.

3.0 SANITARY SEWER

There are existing sanitary sewers within the surrounding Merivale Road, Clyde Avenue, and Baseline Road rights-of-way. There is an existing 200mm diameter sanitary sewer within Merivale Road right-of-way, a 200mm diameter sanitary within the Clyde Avenue right-of-way, and a 300mm sanitary within the Baseline Road right-of-way. Through correspondence with the City of Ottawa it is understood that there are capacity issues within the surrounding sanitary systems that will affect the design of the development. As such the proposed site flows will be split between the surrounding roadways as permitted by the available sewer capacities as detailed in the following sections.

3.1 Design Criteria

Sanitary flows for the proposed development were calculated using criteria from Section 4 of the City of Ottawa Sewer Design Guidelines and the Ontario Building Code as follows:

- Residential Average Flow = 280 L/capita/day
- Single = 3.4 Person/unit
- Townhome unit = 2.7 Person/unit
- Studio Apartment = 1.4 Person/unit
- 1 Bed apartment = 1.4 Person/unit
- 2 Bed apartment = 2.1 Person/unit
- 3 Bed apartment = 3.1 Person/unit
- Commercial flow = 75 L/9.3m²/day
- Parkland flow = 1 unit/ hectare
- Residential Peaking Factor = Harmon Equation (max peaking factor = 4.0)
- Commercial Peaking Factor = 1.0
- Peak Extraneous Flows (Infiltration) = 0.33L/s/ha

3.2 Merivale System (Phase 1)

The Phase One (1) portion of the site will be serviced by utilizing an existing 200mm diameter service on the site which connects to the Merivale Road sanitary sewer along the eastern property boundary. Based on the data available the existing sewer was installed in 1961 and is composed of asbestos cement. The sewer flows to the south-east down Gilbey Drive and is nearly at capacity.

The peak sanitary flow including infiltration for the Phase One (1) development was calculated to be **2.72 L/s**. Through correspondence with the City of Ottawa Senior Water Resources Engineer it is understood that the Merivale/Gilbey system has capacity to take the Phase One (1) development.

Detailed sanitary flow calculations, and correspondence are provided in **Appendix B** for reference.

3.3 Baseline System (Phase 4-6)

Phases Four to Six (4-6) will each have a proposed 200mm sanitary service, for a total of three (3) service connections. The proposed services will connect to the existing 200mm and 300mm diameter sanitary sewers within the Baseline Road right-of-way. Based on the available data the existing sanitary sewers were installed in 1958 and 1965 and are composed of reinforced concrete. The sewer flows to the west down Baseline Road and has capacity for future developments.

The peak sanitary flows for Phases 4, 5, and 6 are **4.06 L/s**, **4.92 L/s**, and **3.92 L/s**, respectively, for a total proposed flow of **12.9 L/s** to the existing Baseline Road sanitary sewer system. Through correspondence with the City of Ottawa Senior Water Resources Engineer it is understood that the Baseline system has capacity for the proposed flows.

Detailed sanitary flow calculations, and correspondence are provided in **Appendix B** for reference.

3.4 Clyde/ Merivale System (Phases, 2-3 & 7-11)

Phases Two to Three (2-3), and Seven to Eleven (7-11), will be serviced by a proposed sanitary sewer system that will direct flows to Clyde Avenue. The proposed sewer system will consist of pipes ranging in size from 200-250mm in diameter and will be routed under proposed Street 1, the proposed Private Road, and an easement along the back of Phase Ten (10). Based on the available data the existing 200mm diameter sanitary sewers within Clyde Avenue were installed in 1977 and are composed of asbestos cement. The existing Clyde sanitary sewer flows north into the Granton Avenue sewer system.

Through correspondence with the City of Ottawa it is understood that the existing sewer is at capacity and has no allowance for the proposed development. It is also understood that the City has plans to extend the existing Merivale Road sanitary sewer up from Cleto to Baseline to alleviate capacity issues and provide allowances for future developments. It is proposed to service the proposed development with the above noted extension.

The peaked design flow from the proposed connection will be **22.20 L/s**, at an invert of **92.10m**. Detailed sanitary flow calculations, and correspondence are provided in **Appendix B** for reference.

4.0 STORM SERVICING

Storm servicing for the 1500 Merivale development will be provided using a dual drainage system: Runoff will be stored and conveyed by an underground storm sewers and storage cisterns (minor system), while flows from large storm events which exceed the capacity of the minor system will be conveyed overland along defined overland flow routes (major system). Runoff from the site is tributary to two outlets:

- The Pinecrest Creek subwatershed via the storm sewers on Baseline Road; and
- The Parkwood Hills subwatershed via the storm sewers on Merivale Road.

There are 900-1050mm diameter storm sewers within the Merivale Road right-of-way, a 375mm diameter storm sewer within the Clyde Avenue right-of-way, and a 300mm diameter storm sewer within the Baseline Road right-of-way. In the present condition the existing commercial sites along Baseline Road drain to private sewers and ultimately the Baseline Road storm sewer systems. The remainder of the site sheet drains to the Merivale Road and Clyde Avenue rights-of-way.

It is proposed to service the proposed site with two (2) connections to the existing Merivale Road storm sewer system, and six (6) connections to the Baseline Road sewer system. Each building will have 2 building services, one (1) uncontrolled outlet for foundation drains, and one (1) controlled outlet to provide quantity control. Refer to the General Plan of Services (drawings 121009-GP1 & GP2) for details.

4.1 Stormwater Management Criteria

The stormwater management criteria used in the design of the proposed development have been based on the *Pinecrest Creek/ Westboro Stormwater Management Retrofit Study* (J.F. Sabourin & Associates Inc, dated May 2011), and the *City of Ottawa Sewer Design Guidelines* (City of Ottawa, dated October 2012), and Technical Bulletins PIEDTB-2016-01, ISTB-2018-01, ISTB-2018-02, and ISTB-2018-03.

4.1.1 Minor System (Storm Sewers)

- Storm sewers are to be designed using the Rational Method for a 2-year return period;
- Underground storage chambers are to be provided to store runoff and attenuate peak flows which exceed the following allowable release rates:
 - For areas tributary to the Pinecrest Creek subwatershed:
 - Minimum on-site retention of the 10mm design storm;
 - Peak flows from the 25mm storm event are not to exceed 5.8L/s/ha;
 - 1:100-year peak flows from the site are not to exceed 33.5L/s/ha;
 - For areas tributary to the Parkwood Hills subwatershed:
 - Peak flows are not to exceed the pre-development peak flow calculated using either the pre-development runoff coefficient or a coefficient of $C=0.5$, whichever is lower, for a 2-year storm event with a 10-minute time of concentration;

4.1.2 Major System

- Provide on-site storage for storm runoff which exceeds the allowable minor system release rate from the site up to and including the 100-year design event;
- Ponding depths are not to exceed 0.35m (static + dynamic) and are not to be within 0.30m (vertical) to the nearest building opening;
- No surface ponding for storms up to and including the 2-year event.

4.1.3 Water Quality Control

- A minimum depth of 300mm amended soil shall be provided below all landscaped areas;
- Per the Pinecrest Creek/ Westboro guidelines, TSS removal is inherent due to the on-site retention in landscaped areas and detention of the 25mm storm event;
- Where possible, implement lot-level and conveyance best management practices to maximize the potential for water quality treatment.

4.2 Storm Sewer Design (Minor System)

The proposed storm sewers have been designed using the Rational Method to convey peak flows associated with a 2-year return period. The storm sewer design sheet is provided in **Appendix C**. The corresponding Storm Drainage Area Plan (**121009-STM**) is provided at the back of this report.

The design criteria used in sizing the storm sewers are summarized below in **Table 4.1**.

Table 4.1: Storm Sewer Design Parameters

Parameter	Design Criteria
Local Roads	2 Year Return Period
Storm Sewer Design	Rational Method
IDF Rainfall Data	Ottawa Sewer Design Guidelines
Initial Time of Concentration (Tc)	10 min
Minimum Velocity	0.8 m/s
Maximum Velocity	3.0 m/s
Minimum Diameter	250 mm

4.2.1 Allowable Release Rates

As outlined in the stormwater management criteria, the allowable release rate from the site is dependant on the subwatershed that the sewer is outletting to.

Pinecrest Creek Subwatershed

For areas tributary to the Pinecrest Creek subwatershed:

- Peak flows from the 25mm storm event are not to exceed 5.8L/s/ha;
- 1:100-year peak flows from the site are not to exceed 33.5L/s/ha;

As such, peak flows for the phases tributary to the Pinecrest Creek Subwatershed are as follows:

Table 4.2: Pinecrest Creek Allowable Release Rates

Phase	Total Area (ha)	25mm Flow (L/s)	100-year Flow (L/s)
PH04	0.242	1	8
PH05	0.618	4	21
PH06	0.472	3	16

As noted in the criteria, the first 10mm of rainfall is required to be captured on site. To meet this criteria, rainwater harvesting, green roofs, and/or infiltration of the runoff should be considered at the detailed design stage.

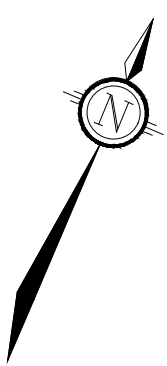
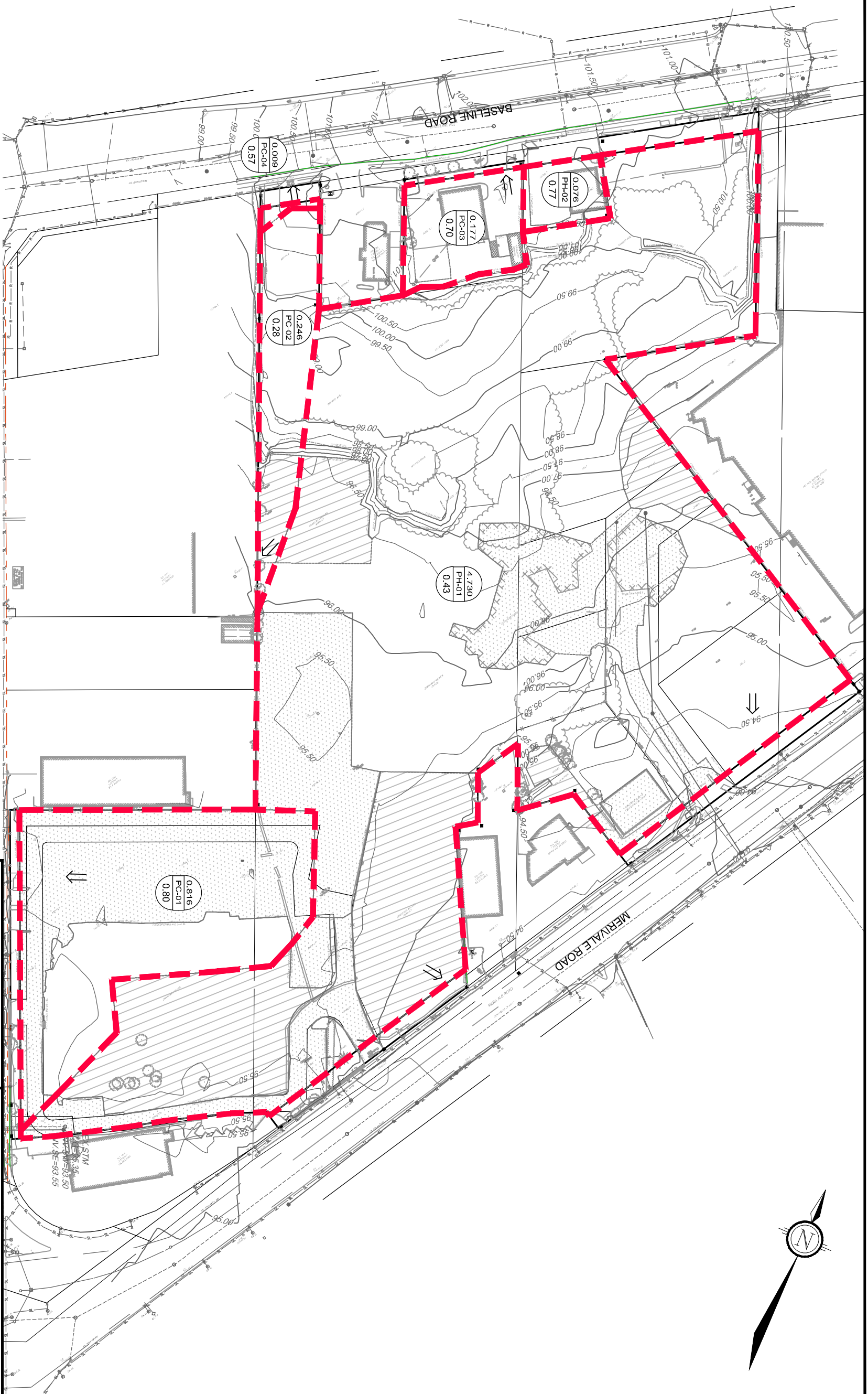

LEGEND

- — — — — PROPERTY LINE
- — — — — EXISTING STORM MANHOLE & SEWER
- — — — — EXISTING CATCHBASIN
- — — — — EXISTING GRASS AND BROKEN ASPHALT / BUILDING RUBBLE
- — — — — EXISTING ASPHALT
- — — — — STORM SEWER DRAINAGE AREA BOUNDARY
- 0.085
A-16
0.78 DRAINAGE AREA (ha)
DRAINAGE AREA ID
RUNOFF COEFFICIENT

NOVATECH

Engineers, Planners & Landscape Architects
 Suite 200, 240 Michael Cowpland Drive
 Ottawa, Ontario, Canada K2M 1P6
 Telephone (613) 254-9643
 Facsimile (613) 254-5867
 Website www.novatech-eng.com

1500 MERIVALE ROAD

**EXISTING STORMWATER
 MANAGEMENT PLAN**

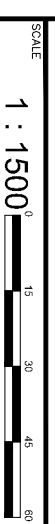

DATE
 MAY 2023

JOB
 121009

FIGURE
 FIGURE 5

Parkwood Hills Subwatershed

For areas tributary to the Parkwood Hills subwatershed:

- Peak flows are not to exceed the pre-development peak flow calculated using either the pre-development runoff coefficient or a coefficient of $C=0.5$, whichever is lower, for a 2-year storm event with a 10-minute time of concentration.

Under existing conditions, the site consists of a combination of paved areas, gravel, forested areas, and sparsely grassed areas, which give an approximate runoff coefficient of $C=0.51$. As such, a runoff coefficient of $C=0.5$ has been used in the Rational Method calculation for the allowable release rate. Calculations as follows:

$$Q_{\text{allowable}} = 2.78CiA \text{ where;}$$

$$C = 0.5$$

$$i = 76.81 \text{ mm/hr (for a 2-year event and } T_c \text{ of 10 mins)}$$

$$A = 4.806 \text{ ha (refer to DWG for total drainage area tributary to the outlet)}$$

$$Q_{\text{allowable}} = 2.78 * 0.5 * 76.81 * 4.806$$

$$Q_{\text{allowable}} = \mathbf{513.1 \text{ L/s}}$$

4.2.2 Orifice Controls

Inflows to the storm sewer from the public and private roadways will be controlled by inlet control devices (ICDs) within the roadway catchbasins. ICDs have been sized to ensure there is no ponding in the right-of-ways during the 2-year storm event.

4.2.3 Water Quality Controls

Per the Pinecrest Creek/ Westboro guidelines, TSS removal is inherent due to the on-site retention in landscaped areas and detention of the 25mm storm event. For outflows tributary to the sewer on Merivale Road, water quality treatment will be provided by OGS units installed upstream of the final outlet to the Merivale Road storm sewer. A Stormceptor EFO6 is proposed in place of MH101 and a Stormceptor EFO8 is proposed in place of MH301. Details of the proposed OGS units have been provided in **Appendix D**.

4.3 On-Site Storage

Due to the combination of the slope of the site limiting ponding within the ROW, parking areas being entirely underground, and restrictive release rates, a substantial amount of underground storage will be required to control peak flows from the site to the allowable release rates. A total storage volume of approximately $3,750 \text{ m}^3$ is required across the entire site.

4.3.1 Overland Flow and Surface Storage (Major System)

Due to the slope of the site, there is very little surface storage within the right-of-ways along both the public and private roadways. Three ponding areas will provide a small amount of surface storage during storm events larger than the 2-year.

4.3.2 Underground Storage

As the allowable release rates for each storm event are quite restrictive, underground storage will be required to attenuate runoff from the site, to ensure the allowable release rates for all

storm events is not exceeded. Each phase will have its own storage cistern, sized to limit peak flows to the storm sewer to a per-hectare allowable release rate. Storage cisterns will generally be located within the parking garages for each phase, with stormwater pumped out to the receiving sewer at the allowable release rate.

Phase 1 will require approximately 293m³ to contain runoff for all storm events, controlling to the allowable release rate, up to and including the stress-test event (100-year +20%). Details of the Phase 1 storage cistern are provided on **121009-NDGP**.

4.4 Hydrologic & Hydraulic Modeling

The *City of Ottawa Sewer Design Guidelines* (October 2012) requires hydrologic modeling for all dual drainage systems. The performance of the proposed storm drainage system for the proposed development was evaluated using the PCSWMM hydrologic/ hydraulic model.

The PCSWMM model schematics and 100-year model output data are provided in **Appendix D**. Digital copies of the modeling files for all storm events are provided with the digital report submission.

4.4.1 Design Storms

The hydrologic analysis was completed using the following synthetic design storms and historical storms. The IDF parameters used to generate the design storms were taken from the *Ottawa Design Guidelines - Sewer* (October 2012).

Chicago Storms:

25mm 4-hour Chicago storm
2-year 3-hour Chicago storm
5-year 3-hour Chicago storm
100-year 3-hour Chicago storm

SCS Type II Storms:

2-year 12-hour SCS Type II storm
5-year 12-hour SCS Type II storm
100-year 12-hour SCS Type II storm

The 3-hour Chicago distribution generates the highest peak flows for both the minor and major systems and was determined to be the critical storm distribution for the design of the storm drainage system.

The proposed drainage system has also been stress tested using a 3-hour Chicago design storm that has a 20% higher intensity and total volume compared to the 100-year event.

4.4.2 Model Development

The PCSWMM model has been developed to account for both minor and major system flows from the proposed development and ensure appropriate storage is provided such that the allowable release rates to each of the outlets are not exceeded. The results of the analysis were used to:

- Determine the total major and minor system runoff from the site;
- Determine the required underground storage volume;
- Calculate the storm sewer hydraulic grade line for the 100-year storm event;
- Evaluate overland flow depths and ponding volumes during the 100-year event.

Although the site is to be developed in multiple phases, the model was built assuming full build-out of the site and includes all phases of the proposed development. This was done to determine the allowable per hectare release rate for each phase and to determine the approximate underground storage volumes for each future phase.

Infiltration

Infiltration losses for all catchment areas were modeled using Horton's infiltration equation, which defines the infiltration capacity of the soil over the duration of a precipitation event using a decay function that ranges from an initial maximum infiltration rate to a minimum rate as the storm progresses. The default values for the City of Ottawa were used for all catchments.

Horton's Equation:	Initial infiltration rate: $f_o = 76.2$ mm/hr
$f(t) = f_c + (f_o - f_c)e^{-k(t)}$	Final infiltration rate: $f_c = 13.2$ mm/hr
	Decay Coefficient: $k = 4.14$ /hr

Depression Storage

The default values for depression storage in the City of Ottawa were used for all catchments.

- Depression Storage (pervious areas): 4.67 mm
- Depression Storage (impervious areas): 1.57 mm

The building rooftops are flat and will provide some depression storage.

Equivalent Width

'Equivalent Width' refers to the width of the sub-catchment flow path. This parameter (Table 5.1) is calculated as described in the *Sewer Design Guidelines, October 2012, Section 5.4.5.6*.

Impervious Values

Runoff coefficients for each subcatchment area were determined based on the proposed site plan. Refer to the Storm Drainage Area Plan (**121009-STM**) for details. Percent impervious values were calculated using the following formula:

$$\%imp = \frac{c - 0.2}{0.7}$$

4.4.3 Storm Drainage Areas

For modeling purposes, the 1500 Merivale lands have been divided into subcatchments based on the drainage areas tributary to each inlet of the proposed storm sewer system. The subcatchment areas are shown on the Storm Drainage Area Plan (**121009-STM**) at the back of this report.

The hydrologic parameters for each subcatchment were developed based on the Site Plan (**Figure 3**) and drawing **121009-STM** specified above. An overview of the modeling parameters is provided in **Table 4.3**. Subcatchment parameters for Phases 2-11 have been lumped into a single catchment area for ease of modelling. At the detailed design stage for each phase, the model will be updated with more detailed catchments for the phase in question.

Table 4.3: Hydrologic Modeling Parameters

Area ID	Catchment Area (ha)	Runoff Coefficient (C)	Percent Impervious (%)	No Depression (%)	Flow Path Length (m)	Equivalent Width (m)	Average Slope (%)
Roadways							
A-01a	0.079	0.78	83%	0%	12.94	61.04	2.5%
A-01b	0.114	0.55	50%	0%	17.55	64.98	2.5%
A-02a	0.043	0.72	74%	0%	8.85	48.57	2.5%
A-02b	0.068	0.74	77%	0%	14.29	47.57	2.5%
A-03a	0.033	0.81	87%	0%	9.11	36.23	2.5%
A-03b	0.046	0.75	79%	0%	13.97	32.93	2.5%
A-04a	0.082	0.86	94%	0%	20.22	40.55	2.5%
A-04b	0.066	0.74	77%	0%	18.48	35.72	2.5%
A-05a	0.078	0.90	100%	0%	18.25	42.73	2.5%
A-05b	0.068	0.75	79%	0%	14.29	47.59	2.5%
A-06a	0.042	0.90	100%	0%	14.32	29.34	2.5%
A-06b	0.039	0.74	77%	0%	14.31	27.25	2.5%
B-01a	0.099	0.82	89%	0%	14.85	66.69	2.5%
B-01b	0.050	0.80	86%	0%	9.74	51.36	2.5%
B-02a	0.029	0.84	91%	0%	10.47	27.70	2.5%
B-02b	0.018	0.90	100%	0%	8.66	20.79	2.5%
B-03a	0.138	0.85	93%	0%	16.43	84.00	2.5%
B-03b	0.054	0.66	66%	0%	5.20	103.88	2.5%
B-04a	0.007	0.90	100%	0%	2.92	23.94	2.5%
B-04b	0.011	0.65	64%	0%	5.04	21.81	2.5%
B-05	0.130	0.86	94%	0%	22.26	58.40	2.5%
Building Phases							
BLDG1	0.151	0.90	100%	0%	30.53	49.46	0.5%
P1-1	0.106	0.51	44%	0%	26.55	51.22	0.5%
P1-2	0.031	0.61	59%	0%	26.55	51.22	0.5%
<i>BLDG2</i>	<i>0.243</i>	<i>0.90</i>	<i>100%</i>	<i>0%</i>	-	-	<i>0.5%</i>
<i>P2-1</i>	<i>0.163</i>	<i>0.20</i>	<i>0%</i>	<i>0%</i>	-	-	<i>0.5%</i>
PH02	0.406	0.62	60%	0%	34.14	118.94	0.5%
<i>BLDG3</i>	<i>0.076</i>	<i>0.90</i>	<i>100%</i>	<i>0%</i>	-	-	<i>0.5%</i>
<i>P3-01</i>	<i>0.065</i>	<i>0.20</i>	<i>0%</i>	<i>0%</i>	-	-	<i>0.5%</i>
PH03	0.141	0.58	54%	0%	41.07	34.33	0.5%
<i>BLDG4</i>	<i>0.242</i>	<i>0.90</i>	<i>100%</i>	<i>0%</i>	-	-	<i>0.5%</i>
PH04	0.242	0.90	100%	0%	86.46	27.99	0.5%
<i>BLDG5</i>	<i>0.336</i>	<i>0.90</i>	<i>100%</i>	<i>0%</i>	-	-	<i>0.5%</i>
<i>P5-1</i>	<i>0.181</i>	<i>0.70</i>	<i>71%</i>	<i>0%</i>	-	-	<i>0.5%</i>

Area ID	Catchment Area (ha)	Runoff Coefficient (C)	Percent Impervious (%)	No Depression (%)	Flow Path Length (m)	Equivalent Width (m)	Average Slope (%)
P5-2	0.101	0.45	36%	0%	-	-	0.5%
PH05	0.618	0.77	81%	0%	73.28	84.28	0.5%
BLDG6	0.190	0.90	100%	0%	-	-	0.5%
P6-1	0.093	0.20	0%	0%	-	-	0.5%
P6-2	0.189	0.76	80%	0%	-	-	0.5%
PH06	0.472	0.71	72%	0%	54.86	86.04	0.5%
BLDG7	0.192	0.90	100%	0%	-	-	0.5%
P7-1	0.115	0.32	17%	0%	-	-	0.5%
PH07	0.307	0.68	69%	0%	42.17	72.80	0.5%
BLDG8	0.191	0.90	100%	0%	-	-	0.5%
P8-1	0.134	0.34	20%	0%	-	-	0.5%
PH08	0.325	0.67	67%	0%	32.95	98.62	0.5%
BLDG9	0.202	0.90	100%	0%	-	-	0.5%
P9-1	0.273	0.81	87%	0%	-	-	0.5%
P9-2	0.126	0.33	19%	0%	-	-	0.5%
PH09	0.601	0.74	77%	0%	95.06	63.26	0.5%
BLDG10	0.326	0.90	100%	0%	-	-	0.5%
P10-1	0.154	0.45	36%	0%	-	-	0.5%
P10-2	0.061	0.40	29%	0%	-	-	0.5%
P10-3	0.088	0.39	27%	0%	-	-	0.5%
PH10	0.629	0.67	67%	0%	94.74	66.36	0.5%
BLDG11	0.111	0.90	100%	0%	-	-	0.5%
P11-1	0.040	0.90	100%	0%	-	-	0.5%
P11-2	0.049	0.20	0%	0%	-	-	0.5%
PH11	0.200	0.73	76%	0%	34.23	58.44	0.5%
Park & Direct Runoff							
PARK1	0.519	0.40	29%	0%	55.30	94.22	1.7%
D-02	0.004	0.90	100%	0%	2.82	14.18	0.5%
D-04	0.011	0.20	0%	0%	3.41	32.23	0.5%

4.5 Minor System Design and Analysis

The following sections outline the model parameters and results of the PCSWMM model, pertaining to the minor system (storm sewers).

4.5.1 Orifice Controls

Inflows to the storm sewer were modeled based on the characteristics of each inlet. Inflows to the storm sewer are based on the orifice specified for the inlet and the maximum depth of ponding. Orifices have been sized to limit the outlet peak flows. Details are outlined as follows in **Table 4.4**.

Table 4.4: Orifice Parameters

Structure	Diameter (mm)	Max. Head (2yr) (m)	Calculated 2yr Capture Rate (L/s)	Model Results*			
				2yr Approach Flow (L/s)	2yr Capture Rate (L/s)	100yr Approach Flow (L/s)	100yr Capture Rate (L/s)
CB01	152	1.22	55.1	18.9	18.8	109.2	8.7
CB02	178	1.11	72.0	19.6	19.5	100.1	12.1
CB03	83	1.17	16.1	14.1	9.3	46.5	19.4
CB04	83	1.17	16.1	18.4	11.1	70.8	19.4
CB05	83	1.42	17.7	16.5	9.3	45.4	19.4
CB06	83	1.42	17.7	16.3	9.2	57.9	19.4
CB07	102	1.15	24.1	30.2	10.7	75.8	21.0
CB08	83	1.16	16.0	17.7	9.1	55.3	19.4
CB09	83	1.16	16.0	20.3	6.7	48.5	13.1
CB10	83	1.16	16.0	14.2	7.4	41.3	17.5
CB11	83	1.16	16.0	9.0	5.3	20.8	11.0
CB12	83	1.16	16.0	6.5	4.0	18.7	10.1
CB13	152	1.12	52.8	21.8	21.7	73.0	0.0**
CB14	83	1.16	16.0	10.5	10.3	66.3	0.0**
CB15	83	1.16	16.0	5.7	2.8	14.2	6.3
CB16	83	1.16	16.0	3.8	2.7	8.9	5.9
CB17	102	1.75	29.7	27.7	27.3	67.9	22.5
CB18	83	1.76	19.7	8.4	8.1	64.0	14.9
CB19	83	1.16	16.0	10.7	0.8	28.9	2.1
CB20	83	1.16	16.0	1.6	1.1	5.2	3.6
CB21	127	1.19	37.9	36.0	35.6	90.2	40.4

*From PCSWMM Model, 2-year & 100-year 3-hour Chicago storm distribution

**Downstream HGL boundary condition is higher than T/G for these CBs, so no inflow occurs

4.5.2 Allowable Release Rate – Parkwood Hills

As noted in Section 4.2.1, the allowable release rate to the Parkwood Hills subwatershed, which the Merivale storm sewer is tributary to, is 513 L/s. To determine a per-hectare release rate which could be applied to each of the development Phases tributary to the Merivale outlets, the total flow from the ROWs and park area was determined by modelling it without any inflows from the various blocks. The flow from the ROWs and park alone accounted for approximately 413L/s, leaving 100L/s to be split between Phases 1-3, and 7-11. Allowable release rates on a per-phase basis are outlined in the table below.

Total area from Phases 1-3 & 7-11 = 2.896 ha
 Allowable per-phase release rate = 100L/s / 2.896ha
 = 35 L/s/ha

Table 4.5: Per Phase Allowable Release Rates

Phase ID	Area (ha)	Allowable Release Rate (L/s)
PH1	0.287	10
PH2	0.406	14
PH3	0.141	5
PH7	0.307	11
PH8	0.325	11
PH9	0.601	21
PH10	0.629	22
PH11	0.200	7

4.5.3 Peak Flows

The modeled peak flows at the various outlets of the 1500 Merivale site for each storm event (25mm, 2-year to 100-year+20%) are summarized in **Table 4.6**. An expanded table with the SCS storm event outflows is provided in **Appendix D**.

Table 4.6: Peak Flows

Storm Distribution->		3hr Chicago				
Return Period->		25mm	2yr	5yr	100yr	100yr +20%
To Merivale Road/ Parkwood Hills Minor System	North Outlet (Minor System)	96	130	202	272	314
	South Outlet (Minor System)	96	131	165	117	130
	Total to Merivale (Minor System)	192	261	367	389	444
To Merivale Road/ Parkwood Hills Major System	Direct Runoff	1	1	2	6	8
	North Outlet (Major System)	0	0	0	146	223
	South Outlet (Major System)	0	0	0	103	120
	Total to Merivale (Major System)	1	1	2	255	351
To Baseline/ Pinecrest Creek	Phase 4	1	3	5	8	9
	Phase 5	4	5	10	18	21
	Phase 6	3	4	4	15	17

The results of the PCSWMM analysis indicate that outflows from the proposed development to the Pinecrest Creek subwatershed will not exceed allowable release rates as outlined in **Section 4.2.1, Table 4.2**.

Inflows to the Merivale Road minor system (Parkwood Hills subwatershed) will not exceed the allowable release rate for all storm events. However, peak flows from the major system during the 100-year event bring the total release rate above the allowable 513 L/s during the 100-year event. Given the downstream boundary conditions in the Merivale storm sewer are at the manhole T/G, there is significant backup of flows into the 1500 Merivale development sewer and surcharging from the manholes within the development. As such, storage provided within the

ROW by the low points is taken over by outflows from the storm sewers, resulting in overland flow to Merivale Road.

4.5.4 Hydraulic Grade Line

The results of the analysis were used to determine if there would be any surcharging from the storm sewer system during the 100-year storm event. As noted above, since the downstream boundary conditions during the 100-year event are at the manhole T/G already and buildings are to have underground parking areas, HGL elevations were analyzed on the clearance from the T/G and not clearance to the USF. There will be no habitable basements within the development, and backwater valves will be placed on the storm outlets for the foundation drains and cisterns, which will both be pumped into the receiving storm sewers.

The **Table 4.7** provides a summary of the 100-year HGL elevation at each storm manhole within the proposed development, as well as a summary of the HGL elevations for a 20% increase (rainfall intensity and total precipitation) in the 100-year design event.

Table 4.7: Storm Sewer Hydraulic Grade Line

Manhole ID	MH Invert Elevation (m)	T/G Elevation (m)	HGL Elevation 100yr-3hr (m)	HGL Elevation 100yr-3hr +20% (m)	Clearance from T/G (100yr) (m)	Clearance from T/G (100yr+20%) (m)
MH101	92.23	94.06	94.09	94.11	-0.03	-0.05
MH102	92.27	94.08	94.10	94.12	-0.02	-0.04
MH103	92.42	94.06	94.14	94.18	-0.08	-0.12
MH104	92.58	94.68	94.26	94.35	0.42	0.33
MH105	93.88	96.56	94.55	94.69	2.01	1.87
MH106	94.35	97.17	94.65	94.81	2.52	2.36
MH107	94.88	97.97	95.04	95.07	2.93	2.90
MH108	95.89	98.59	96.01	96.02	2.58	2.58
MH109	98.63	101.56	98.70	98.71	2.86	2.85
MH301	92.62	94.56	94.75	94.75	-0.19	-0.19
MH302	92.70	94.55	94.75	94.75	-0.20	-0.20
MH303	92.75	94.49	94.75	94.75	-0.26	-0.26
MH304	92.80	94.52	94.75	94.76	-0.23	-0.23
MH305	92.89	94.58	94.76	94.76	-0.17	-0.18
MH306	93.01	95.06	94.77	94.78	0.29	0.28
MH307	93.07	95.70	94.79	94.79	0.91	0.91
MH308	93.33	95.87	94.85	94.86	1.02	1.01
MH309	93.74	96.27	94.87	94.89	1.40	1.38
MH310	94.02	96.50	94.89	94.91	1.61	1.59
MH311	94.89	97.19	94.93	94.94	2.26	2.25

4.5.5 Underground Storage Volumes

Approximate underground storage volumes for each phase are outlined in **Table 4.8**. During the detailed design stage for each phase, the exact required volume will be refined.

Table 4.8: Storage Required

Phase	Area	Storage Required (m ³)	Storage Required per Hectare (m ³ /ha)
PH01	0.287	258	899
PH02	0.406	334	824
PH03	0.141	27	191
PH04	0.242	124	513
PH05	0.618	291	470
PH06	0.472	202	428
PH07	0.307	160	521
PH08	0.325	305	939
PH09	0.601	696	1158
PH10	0.629	665	1058
PH11	0.2	310	1548

4.6 Major System Design and Analysis

The major system network was evaluated using the PCSWMM model to ensure that the ponding depths conform to City standards. A summary of ponding depths and volumes for the 100-year event is provided in **Table 4.9**. Ponding depths for all storm events (2yr to 100yr+20%) are provided in **Appendix D**.

Table 4.9: Ponding Depths at Catchbasins (100yr Event)

Structure	T/G (m)	Max. Static Ponding (Spill Depth)		2-yr Event (3hr)				Min. Adjacent Building Opening (m)
		Elev. (m)	Depth (m)	Elev. (m)	Depth (m)	Cascading Flow?	Cascade Depth (m)	
CB01	93.97	94.07	0.10	92.89	0.00	N	0.00	94.22
CB02	93.97	94.07	0.10	92.94	0.00	N	0.00	94.22
CB13	94.44	94.55	0.11	93.51	0.00	N	0.00	94.70
CB14	94.44	94.55	0.11	93.76	0.00	N	0.00	94.70
CB17	95.70	95.84	0.14	95.43	0.00	N	0.00	95.99
CB18	95.70	95.84	0.14	94.24	0.00	N	0.00	95.99
CB21	96.60	96.80	0.20	96.46	0.00	N	0.00	96.95

5.0 WATERMAIN

The subject property is within both the City of Ottawa pressure Zone ME, and Zone 2W2C. The pressure zone split crosses through the northern portion of the subject site. There is an existing 300mm diameter ductile Iron watermain within the Merivale Road right-of-way, a 300mm diameter PVC watermain within the Clyde Avenue right-of-way, and a 400mm diameter cast iron watermain in the Baseline Road right-of-way. The proposed development will include a 200mm public watermain within the proposed Street 1, and Private Road rights-of-way which will connect to the existing Merivale Road watermain in two (2) locations. Phases 1-3, and 7-11 will be serviced from the proposed watermain within the Street 1, and Private Road rights-of way. Phases 4-6 will be serviced by connecting each phase directly to the existing 400mm watermain within the Baseline Road right-of-way.

As per the City of Ottawa Technical Bulletin ISDTB-2014-02, each proposed building service will consist of twin 200mm watermains separated by an isolation valve in the right-of-way. The proposed buildings will be sprinklered and equipped with Siamese connections. Each Siamese connection has been placed to be within 45m of a fire hydrant. Refer to the General Plan of Services drawing (121009-GP1&2), and the Coverage plans included in **Appendix E** for details.

As noted above the Merivale Road and Baseline Road watermain are within two (2) distinct pressure zones. As such the on-site water servicing will not be interconnected. Refer to **Figure 6: Pressure Zone Plan** for details.

For this site the water demands will be detailed by Phase, and pressure zone. Water demands have been calculated using criteria from Section 4 of the City of Ottawa Water Distribution Guidelines and the Ontario Building Code. The required fire demands have been calculated using the Fire Underwriters Survey (FUS) Guidelines. The water demand and fire flow calculations are provided in **Appendix E** for reference. A summary of the water demand and fire flows are provided in **Table 5.1, and Table 5.2** below.

Table 5.1: Merivale Road Domestic Water Demand Summary

Phase	Population	Ave. Daily Demand (L/s)	Max. Daily Demand (L/s)	Peak Hour Demand (L/s)	Fire Flow (L/s)
Phase 1	229	0.759	1.881	4.128	67
Phase 2	440	1.437	3.580	7.868	83
Phase 3	126	0.408	1.021	2.246	33
Phase 7	262	0.848	2.120	4.665	83
Phase 8	301	0.976	2.439	5.367	100
Phase 9	326	1.072	2.665	5.854	100
Phase 10	478	1.587	3.928	8.618	117
Phase 11	173	0.576	1.423	3.121	67
Park	--	0.002	0.005	0.010	N/A
Total	2320.5	7.66	19.06	41.88	



M:\2021\121009\CAD\Design\Figures\Brief\Figure 5- pressure.dwg, PZP, Dec 05, 2022 - 10:44am, amestwarp



Engineers, Planners & Landscape Architects
 Suite 200, 240 Michael Cowpland Drive
 Ottawa, Ontario, Canada K2M 1P6

Telephone (613) 254-9643
 Facsimile (613) 254-5867
 Website www.novatech-eng.com

CITY OF OTTAWA
 1500 MERIVALE ROAD

PRESSURE ZONE PLAN

SCALE

N.T.S

DATE

DEC 2022

JOB

121009

FIGURE

FIGURE-6

Table 5.2 Baseline Road Domestic Water Demand Summary

Phase	Population	Ave. Daily Demand (L/s)	Max. Daily Demand (L/s)	Peak Hour Demand (L/s)	Fire Flow (L/s)
Phase 4	354	1.160	2.888	6.347	100
Phase 5	426	1.389	3.463	7.613	133
Phase 6	337	1.096	2.735	6.014	117
Total	1117	3.64	9.09	19.974	

The water demand information for the site was previously submitted for a slightly lower site demand for the Merivale Road connection as summarized in **Table 5.3** below.

Table 5.3: Merivale Road Domestic Water Demand Summary

Phase	Population	Ave. Daily Demand (L/s)	Max. Daily Demand (L/s)	Peak Hour Demand (L/s)	Fire Flow (L/s)
Total	2320.5	7.62	18.95	41.63	

The slight difference in demand is considered negligible and would have a negligible impact on the boundary Head elevations. The above water demand information based was submitted to the City for boundary conditions from the City's water model. Refer to **Table 5.4** for a summary of the boundary conditions.

Table 5.4: Water Boundary Conditions

Criteria	Demand (L/s)	Head (m)
Connection 1 (Merivale Road) – Zone ME		
Max HGL	7.62	157.9
Min HGL	41.63	144.7
Max Day + Fire Flow	135.95	152.8
Connection 2 (Merivale Road) – Zone ME		
Max HGL	7.62	157.9
Min HGL	41.63	144.7
Max Day + Fire Flow	135.95	152.8
Connection 3 (Baseline Road) – Zone 2W2C [Phase 6]		
Max HGL	1.096	133.0
Min HGL	6.014	124.9
Max Day + Fire Flow	135.735	127.5

Criteria	Demand (L/s)	Head (m)
Connection 4 (Baseline Road) – Zone 2W2C [Phase 4]		
Max HGL	1.160	133.0
Min HGL	6.347	124.9
Max Day + Fire Flow	135.88	127.4
Connection 5 (Baseline Road) – Zone 2W2C [Phase 5]		
Max HGL	1.389	133.0
Min HGL	7.613	124.9
Max Day + Fire Flow	136.463	127.2

5.1 Ultimate Build-out

The following is an analysis of the complete build-out of the development. A detailed analysis for each phase will be completed with the future site plan applications.

5.1.1 Merivale System

The above boundary conditions were used to create a hydraulic model using EPANET for analyzing the performance of the proposed watermain system for three theoretical conditions: 1) High Pressure check under Average Day conditions, 2) Peak Hour Demand, 3) Maximum Day + Fire Flow Demand. The following **Table 5.4** provides a summary of the results from the hydraulic water model.

Table 5.5: Water Analysis Summary

Condition	Demand (L/s)	Min/Max Allowable Operating Pressures (psi)	Limits of Design Operating Pressures (psi)
High Pressure	7.62 L/s	80psi (Max)	90.74psi
Maximum Daily Demand and Fire Flow	101.95 L/s	20psi (Min)	68.48psi
Peak Hour	10.97 L/s	40psi (Min)	63.85psi

The above table lists the worst-case pressures from the water model analysis.

The hydraulic analysis indicates that the system can provide adequate pressures and flow to meet the domestic and fire flow requirements for the site. Due to pressures being above 80psi pressure reducing valves will be required on the proposed services. Refer to **Appendix E** for detailed water demand calculations, and City of Ottawa boundary conditions.

5.1.2 Baseline System

The above boundary conditions were used for analyzing the performance of the proposed and existing watermain systems for three theoretical conditions:

- 1) High Pressure check under Average Day conditions
- 2) Peak Hour demand
- 3) Maximum Day + Fire Flow demand.

Refer to **Table 5.5** for a summary of the proposed boundary conditions and hydraulic analysis.

Table 5.6: Water Boundary Conditions and Hydraulic Analysis Summary

Criteria	Head (m)	Pressure ¹ (psi)	Pressure Requirements (psi)
Connection 3 (Baseline Road) – Zone 2W2C [Phase 6]			
Max HGL	133.0	49.14	< 80psi
Min HGL	124.9	37.63	> 40psi
Max Day + Fire Flow	127.5	42.32	> 20psi
Connection 4 (Baseline Road) – Zone 2W2C [Phase 4]			
Max HGL	133.0	47.22	< 80psi
Min HGL	124.9	35.71	> 40psi
Max Day + Fire Flow	127.4	39.26	> 20psi
Connection 5 (Baseline Road) – Zone 2W2C [Phase 5]			
Max HGL	133.0	48.63	< 80psi
Min HGL	124.9	37.11	> 40psi
Max Day + Fire Flow	127.2	40.38	> 20psi

¹Pressure based on a Water Entry elevation of 98.44m for phase 6, 99.79m for phase 4, 98.80m for phase 5

The hydraulic analysis indicates that the system can provide adequate pressures and flow to meet the domestic and fire flow requirements in all scenarios other than the peak hour. As the proposed buildings are mid-rise apartments, the buildings will include pumps for the upper floors which will regulate the internal water pressures and mitigate any low pressures encountered during the peak hour. Refer to **Appendix E** for detailed water demand calculations, and City of Ottawa boundary conditions.

6.0 EROSION AND SEDIMENT CONTROL

Temporary erosion and sediment control measures will be implemented on-site during construction in accordance with the Best Management Practices for Erosion and Sediment Control. This includes the following temporary measures:

- Filter socks (catchbasin inserts) will be placed in existing and proposed catchbasins and catchbasin manholes, and will remain in place until vegetation has been established and construction is completed;
- Silt fencing will be placed along the surrounding construction limits;
- Mud mats will be installed at the site entrances;
- Strawbale or rock check dams will be installed in swales and ditches;
- The contractor will be required to perform regular street sweeping and cleaning as required, to suppress dust and to provide safe and clean roadways adjacent to the construction site;

Erosion and sediment control measures should be inspected daily and after every rain event to determine maintenance, repair or replacement requirements. Sediments or granulars that enter site sewers shall be removed immediately by the contractor. These measures will be implemented prior to the commencement of construction and maintained in good order until vegetation has been established. Refer to the Erosion and Sediment Control Plan (drawing 121009-ESC) for additional information.

7.0 CONCLUSIONS AND RECOMMENDATIONS

Sanitary Servicing

The analysis of the existing and proposed sanitary system confirms the following:

- It is proposed to service the Phase 1 development utilizing the existing 200mm sanitary service to Merivale Road
- Phases 2-3, and 7-11 will be serviced by a proposed 200-250mm diameter sanitary sewer that will connect to the future Merivale Road sanitary expansion as noted on the IMP
- Phases 4-6 will be serviced by individual 200mm diameter sanitary services to Baseline Road
- There is adequate capacity within city infrastructure downstream from the development for Phase 1, and Phases 4-6. Adequate capacity for Phases 2-3 and 7-11 will be provided following the future sanitary expansion along Merivale Road.

Stormwater Management

The following provides a summary of the storm sewer and stormwater management system:

- The proposed storm sewer systems are to connect to the 900mm and 1050mm diameter storm sewers in the Merivale Road right-of-way. The sewer systems will provide storm conveyance for Phases 1-3, and 7-11
- Phases 4-6 will be serviced by direction connections to the existing storm sewers within the Baseline Road right-of-way
- Stormwater control for the individual phases will be provided by cisterns within the P1 parking levels.
- As per the proposed grading plans, major overland flow routes have been provided to the surrounding rights-of-way.

Watermain

The analysis of the existing and proposed watermain network confirms the following:

- The proposed 200mm diameter water main proposed under Street 1 and the Private Road with two proposed connections to the existing watermain within the Merivale Road right-of-way has capacity to service the development.
- Phases 4-6 will be serviced by the existing Baseline Road watermain system with individual dual services separated by Isolation valves. The proposed buildings will require pumps to increase the pressure during the peak hour event.
- There are adequate pressures in the existing watermain infrastructure to meet the required domestic demands for the development.
- There is adequate flow to service the proposed fire protections system.

Erosion and Sediment control

- Erosion and sediment control measures (i.e. filter fabric, catchbasin inserts, silt fences, etc.) will be implemented prior to construction and are to remain in place until vegetation is established.

8.0 CLOSURE

This report is respectfully submitted for review and approval. Please contact the undersigned should you have questions or require additional information.

NOVATECH

Prepared by:

Stormwater Modeling by:

Anthony Mestwarp, P.Eng
Project Manager
Land Development Engineering

Kallie Auld, P.Eng.
Project Manager
Water Resources

Report Reviewed by:

Greg MacDonald, P.Eng.
Director, Land Development and Public Sector Infrastructure

Appendix A
Pre - Consultation Meeting Minutes

ADDRESS 1500 Merivale Road
Pre-Consultation Meeting Minutes
Meeting Date: March 25, 2021

Attendee	Role	Organization
Lisa Stern	File Lead	City of Ottawa
Mark Young	Urban Designer	
Santosh Kuruvilla	Infrastructure Project Manager	
Mike Giampa	Transportation Project Manager	
Louise Cervený	Parks Planner	
Kersten Nitsche	Planner	Fotenn
Brian Casagrande	Planner	
Vincent Denomme	Landowner	Claridge Homes
Neil Malhotra	Landowner	
Nathan Godlovitch	Architect	Evoq Architecture
Sayeh Jolan		
Etienne Forget		
Brad Byvelds		Novatech
Jennifer Luong		
Doug Yonson	Community Association Representative	Fisher Heights Area Community Association
Tony Sroka	Community Association Representative	

Comments from the Applicant:

1. Have proposed a built form that meets the zoning.
2. Have proposed a mainly a mid-rise residential built form with approximately 2000 units.
3. A public park is proposed at the south end of the site.
4. The build out of the site will occur over time. Build out may take 20 years.

Planning Comments:

1. The application will require a complex site plan application. The application form, timeline and fees can be found [here](#).
2. The subject lands are designated Arterial Mainstreet in the City's Official Plan and are zoned Zoning: AM10[2217] H(34)
 - a. Exception: - for lots greater in area than 1250 m², 2% of the total lot area must be provided as outdoor communal space located at grade anywhere on the lot and such area can also be used towards complying with any amenity area requirements
3. The site is within the boundaries of the Merivale Road Secondary Plan.
4. Please keep apprised of the direction in the draft Official Plan.
5. Guidelines for Arterial Mainstreets, TOD development, Bird Friendly Design Guidelines apply.
6. There was a motion made at Council to *"add the completion of an urban design analysis of the Merivale Triangle to the Planning, Infrastructure and Economic Development Department's multi-year workplan, and direct staff to undertake this analysis as soon as feasible"*.

7. Please provide a Planning Rationale which discusses how the proposal meets the intent of policy and guidelines. A high quality built form and pedestrian oriented public realm is expected.
8. In light of the amenity space requirements of the site specific zoning exception and the requirement to provide parkland on site, please discuss the objectives/rationale for the open space network provided in the Planning Rationale report and how it meets the intent of the Secondary Plan and relevant guidelines.
9. While it is recognized that the proposal conforms to the Zoning of the site, staff strongly recommend consideration of varying building typologies and heights to visually break up the site, provide opportunities for placemaking and to provide increased densities in proximity to Rapid Transit.
10. Both the Arterial Mainstreet designation and the Secondary Plan speak to providing a mix of uses a mix of uses that is compact in urban form, and pedestrian-oriented and transit friendly places. Please examine providing commercial/retail uses at grade to animate roadway frontages and public space.
11. The secondary plan recognizes that this property is very complex and are subject to a number of development constraints arising from the existing development pattern and the complexity of the land ownership. The secondary plan states that as a result, proposals to develop this area may be considered on a staged basis to accommodate a transition to a more coordinated and integrated built form. It is not clear that the proposed plan considers transitions to surrounding properties.
 - Please provide a concept and phasing plan for the entire triangle area to ensure that non-participatory properties can be developed in a logical and cohesive fashion.
 - Provide a concept plan to show how surrounding properties will develop and be integrated with park uses and illustrate how loading and access on adjacent sites can be integrated/buffered.
12. Connectivity through the site to BRT is important to provide for active transportation connections and to meet the objectives of the OP, Secondary Plan and applicable guidelines. The Secondary Plan specifically contemplates a roadway and cycling access through the site. Public access should be provided through the site. Public Roadway would be preferable to provide public frontage on Park, consolidate accesses between sites and provide public access to BRT.
13. Please consider building placement and orientation to frame public/private roadways to compliment the configuration of adjacent buildings. Please consider orienting buildings so that the massing reinforces the street/private way edge.
14. Please consider breaking up the long buildings provide opportunities for physical and visual connections. Connections should be provided to create pedestrian and cycling links and overall site permeability. Connections to/from surrounding properties to the park/open space and BRT should be considered in design.
15. Staff appreciates the provision of underground parking. Please ensure that the extent of underground parking structures will not inhibit the provision of large tree planting on the site.
16. Staff would appreciate the opportunity for further consultation/discussion as the proposal is refined in order provide more detailed comments regarding public space, infrastructure and access.
17. Please consult with the Ward Councillor and Community Association prior to submission.

Urban Design:

1. Please ensure that the proposed applications conform to the Merivale Road Secondary Plan.

2. Please consult and address the Design Guidelines prepared for the Secondary Planning area by the Planning Partnership in 1998. These guidelines provide additional guidance that should be considered and addressed based on Secondary Plan policy 5.2:

5.2 The Urban Design Guidelines developed as part of the Secondary Plan process are instrumental in the formulation and achievement of the land use and design vision for the Merivale Road Corridor. Although some of the policies of this Plan derived difficulty from the Urban Design Guidelines and are intended to assist in the achievement of this vision, it must be demonstrated to the satisfaction of the City that development proposals comply with their specific direction and general intent.

3. A site of this size requires a Neighbourhood Approach to Planning vs. a Site Planning Approach.
4. The current approach appears to be rooted in a Campus approach and does not appear to consider a higher-level approach to neighbourhood building.
5. There is a need to look at the entire picture and the surrounding context of this site and use this to inform the design. This should consider how abutting sites can be integrated into the new neighbourhood fabric if and when they redevelop. Many of the adjacency relationships shown are not appropriate. This is considered in the Secondary Plan policies and should be provided as part of a design brief submission.

3.1.1.2 1.a. viii. Lands within the triangle formed by Merivale Road, Clyde Avenue and Baseline Road are subject to a number of development constraints arising from the existing development pattern and the complexity of the land ownership. As a result, proposals to develop this area may be considered on a staged basis to accommodate a transition to a more coordinated and integrated built room.

6. Additional Connectivity and permeability should be sought, in the form of additional publicly accessible connections, including public streets as indicated in the Secondary Plan.

3.1.4.1.1.a.ii Road systems should be introduced within large blocks, particularly those on the east side of Merivale Road and the Clyde Avenue/Merivale Road/Baseline Road "triangle", to increase their permeability and to distribute traffic more evenly while minimizing the number of driveways on Merivale Road and Clyde Avenue.

3.1.3.1.1.a.i. Council shall require that new roads be incorporated in proposals for development and redevelopment along Merivale Road. Conceptual corridors for some of these roads have been identified on Schedule 2 while others, such as in the area of the triangle of lands formed by Merivale Road, Clyde Avenue and Baseline Road will be identified during the review of development applications.

3.1.3.1.1.a.ii. New roads required by Council are not necessarily intended to be in public ownership in all cases but may be privately-built roads designed to public road standards.

7. Creation of a meaningful public realm both internal and external to the site is key to the success of the project. Need to consider which elements will make that public realm a success. Elements should include:

- a. At grade activation and animation both internal and external to the site. Secondary Plan 3.1.1.2.1.a.vii
 - b. Enhancements in the treatment of the public realm along all three arterial road frontages. Secondary Plan 3.1.1.3
 - c. Active transportation connections through the site for pedestrians and cyclists. Secondary Plan 3.1.2.2
 - d. Provision of an urban tree canopy in the neighbourhood.
 - e. The incorporation of a public park as a focal point for the neighbourhood.
 - f. Built form relationships to the public realm.
 - g. Shadowing and Wind – impacts on the public realm.
 - h. The provision of grade related units.
 - i. Ensuring that parking and “functional” (loading, refuse collection etc.) elements to the project are not prominent in the public realm.
8. The proposal will be subject to Urban Design Review Panel. A pre-consultation with the Panel is recommended as a first step in the design process.
 9. A Design Brief will be required in support of the application. A Terms of Reference is attached.
 10. PRUD staff support the concept of a green passage and pedestrian connectivity in a north/south orientation across the site. There is a serious concern that this grand design gesture will be pinched at north end in the vicinity of the Tim Horton’s Site. The connection point to Baseline Road needs to be strengthened.
 11. PRUD staff appreciate the applicants desire to locate as much parking below grade as possible.
 12. PRUD are concerned with a lack of mixed uses on-site. The approach to solely residential is not appropriate in the planning of a site/neighbourhood of this size. Secondary Plan Policy 3.2.1.2 requires the following:

Residential uses located adjacent to Merivale Road shall only be permitted to be located above ground level retail or office uses. Stand alone residential uses may not be permitted at locations fronting onto Merivale Road or Clyde Avenue.
 13. PRUD staff are concerned with the lack of consideration and setbacks to abutting sites, and the proposed orientation of dwelling units.
 14. PRUD staff question the use of only a Bar built form for the entire site. Consideration should be given to a combination of built forms, and buildings including the use of high-rise typologies.
 15. Please consider buffering from existing and proposed loading areas/back of house functions early in the design process. Secondary Plan 3.1.3.3.
 16. Please be aware of the recent Council adopted motion related to the design of these lands.

Parks

1. Further Parks conditions and requirements for parkland dedication will apply upon review of formal development submission.
2. Maximum Parkland dedication will be taken on the development site, based on the total amount of land developed or the number of units per hectare, which ever is greatest.
3. In the event that there is a change in the proposed use, block area, residential product and/or number of dwelling units within the Final Plan, the required parkland dedication will also be subject to change.
4. The surrounding streets of Baseline, Clyde and Merivale are busy, often congested and do not provide the necessary and safe frontage for a park. One large and centrally located park parcel is required to provide maximum benefit to the new community and surrounding neighbourhoods.

5. Small parkettes on remnant, undevelopable land will not be considered.
6. A facility fit plan for the park is required. The overall plan shall include park layout, proposed amenities, grading plan and tree planting plan.
7. No encumbrances on the park land are permitted including utilities, stormwater management facilities, or overland drainage from the development.
8. Park servicing is required.
9. Pedestrian linkages (as registered easements) from the surrounding roads offering access to the park and circulation through the site are required. As indicated in the, “useable and clearly identifiable network of open space” as indicated in the Merivale Road Secondary Plan (P.9).
10. Consider impact of north wind/tunnel effect through the development and to the park location and open spaces.

Transportation:

1. Proceed to TIA step2, scoping. The application will not be deemed complete until the submission of the draft step 2-4, including the functional draft RMA package (if applicable) and/or monitoring report (if applicable).
2. Although a full review of the TIA Strategy report (Step 4) is not required prior to an application, it is strongly recommended.
3. Synchro files are required at Step 4.
4. Please note that all new applications (pre-consultation meetings dated after March 3, 2021) must use the NEW TRANS Trip Generation Manual when forecasting site generated trips using this manual. The TRANS committee (a joint transportation planning committee serving the National Capital region) finalized a new manual early in March 2021. The document will be available in French and English on the TRANS website <http://www.ncr-trans-rcn.ca/surveys/2009-trip-generation>.
5. Any access to Baseline Road must be coordinated with the Baseline BRT reconstruction and will be right in right out only due to the ultimate center median. Full movement access may be provided on Merivale Road subject to the TIA analysis and enough spacing from any existing traffic control. All road modifications are at the applicant’s cost.
6. ROW protection on Baseline and Merivale is 44.5 m and 37.5m.
7. Corner sight triangles: 5m x 5m minimum.
8. A Road Noise Impact Study is required
9. ROW protections are:
 - Baseline is 30 m, protected for 44.5 m
 - Clyde is 30 m, protection is 34 m
 - Merivale is 30 m, protection is 44.5 m

Infrastructure:

1. The Servicing Study Guidelines for Development Applications are available at the following link: <https://ottawa.ca/en/city-hall/planning-and-development/information-developers/development-application-review-process/development-application-submission/guide-preparing-studies-and-plans>
2. Record drawings and utility plans are available for purchase from the City’s Information Centre. Contact the City’s Information Centre by email at informationcentre@ottawa.ca or by phone at (613) 580-2424 x44455
3. Stormwater quantity control criteria:

- a. Discharge to the north (baseline) will have to follow the very strict Pinecrest creek criteria (full retention/infiltration of first 10 mm and then control the remainder of the flow to 34.5 L/s/ha).
- b. Discharge to Merivale, will go into Parkwood hills, which only has 2 year capacity. Will need to control to the 2 year using $C=0.5$, but we will also need to enter their flow into our flood risk model to see what the downstream impact is. Most of the site already drains there, so we will just confirm the impact of their flows in the model.



4. Potential outlets and allowable sanitary discharge - Please see attached email from Eric Tousignant, dated March 19, 2021.
5. Existing sanitary sewers are available on Merivale Road (200 mm dia.), Clyde Ave. (200 mm dia.), and Baseline Road (300 mm dia.).
6. Existing storm sewers are available on Merivale Road (900 mm dia.), Clyde Ave. (375 mm dia.), and Baseline Rd. (300 mm dia.).
7. Existing watermains are available on Merivale Road (203 mm dia., 305 mm dia.), Clyde Ave. (305 mm dia.), and Baseline Road (406 mm dia.).
8. Looping is required for water.
9. Stormwater quality control – Consult with the Conservation Authority (RVCA) for their requirements. Include the correspondence with RVCA in the stormwater/site servicing report.
10. Please note that as per Technical Bulletin PIEDTB-2016-01 section 8.3.11.1 (p.12 of 14) there shall be no surface ponding on private parking areas during the 2-year storm rainfall event. Depending on the SWM strategy proposed underground or additional underground storage may be required to satisfy this requirement.

11. Please note that the minimum orifice dia. for a plug style ICD is 83mm and the minimum flow rate from a vortex ICD is 6 L/s in order to reduce the likelihood of plugging.
12. Please provide an Existing Conditions/Removals Plan as part of the engineering drawing set. Any existing services are to be removed or abandoned in accordance with City standards.
13. As per the City of Ottawa Slope Stability Guidelines for Development Applications an engineering report is required for any retaining walls proposed 1.0 m or greater in height within the subject site that addresses the global stability of the wall and provides structural details. A Retaining Wall Stability Analysis Report and Retaining Wall Structural Details are required to be provided from a Professional Engineer licensed in the Province of Ontario that demonstrates the proposed retaining wall structure has been assessed for global instability as per City standards. Please ensure the analysis and required documentation are provided as part of the submission to address this comment.
14. Emergency routes will need to be satisfactory to Fire Services. Please show fire routes on the site plan. For information regarding fire route provisions, please consult with Kevin Heiss at kevin.heiss@ottawa.ca.
15. Clearly show and label the property lines on all sides of the property.
16. Clearly show and label all the easements (if any) on the property, on all plans.
17. When calculating the post development composite runoff coefficient (C), please provide a drawing showing the individual drainage area and its runoff coefficient.
18. When using the modified rational method to calculate the storage requirements for the site, the underground storage should not be included in the overall available storage. The modified rational method assumes that the restricted flow rate is constant throughout the storm which, in this case, underestimates the storage requirement prior to the 1:100-year head elevation being reached. Alternately, if you wish to include the underground storage, you may use an assumed average release rate equal to 50% of the peak allowable rate. Otherwise, disregard the underground storage as available storage or provide modeling to support the design.
19. Engineering plans are to be submitted on standard A1 size (594mm x 841mm) sheets.
20. Phase 1 ESA and Phase 2 ESA must conform to clause 4.8.4 of the Official Plan that requires that development applications conform to Ontario Regulation 153/04.
21. Provide the following information for water main boundary conditions:
 - a. Location map with water service connection location(s).
 - b. Average daily demand (l/s).
 - c. Maximum daily demand (l/s).
 - d. Maximum hourly demand (l/s).
 - e. Fire flow demand (provide detailed fire flow calculations based on Fire Underwriters survey (FUS) Water Supply for Public Fire Protection). Exposure separation distances shall be defined on a figure to support the FUS calculation and required fire flow (RFF).
22. Hydrant capacity shall be assessed to demonstrate the RFF can be achieved. Please identify which hydrants are being considered to meet the RFF on a fire hydrant coverage plan as part of the boundary conditions request.
23. If you are proposing any exterior light fixtures, all must be included and approved as part of the site plan approval. Therefore, the lights must be clearly identified by make, model and part number. All external light fixtures must meet the criteria for full cut-off classification as recognized by the Illuminating Engineering Society of North America (IESNA or IES), and must result in minimal light spillage onto adjacent properties (as a guideline, 0.5 fc is normally the maximum allowable spillage). In order to satisfy these criteria, the applicant must provide certification from an acceptable professional engineer. The location of all exterior fixtures, a

table showing the fixture types (including make, model, part number), and the mounting heights must be included on a plan.

24. As per Ottawa Sewer Design Guideline section 4.4.4.7, a monitoring maintenance hole shall be required just inside the property line for all non-residential and multi residential buildings connections from a private sewer to a public sewer. See the sewer use By-law 2003-514(14) monitoring devices for details.

Forestry

TCR requirements:

1. a Tree Conservation Report (TCR) must be supplied for review along with the suite of other plans/reports required by the City
 - a. an approved TCR is a requirement of Site Plan approval.
2. As of January 1 2021, any removal of privately or publicly (City) owned trees 10cm or larger in diameter requires a tree permit issued under the Tree Protection Bylaw (Bylaw 2020 – 340); the permit will be based on an approved TCR and made available at or near plan approval.
3. The Planning Forester from Planning and Growth Management as well as foresters from Forestry Services will review the submitted TCR
 - a. If tree removal is required, both municipal and privately-owned trees will be addressed in a single permit issued through the Planning Forester
 - b. Compensation may be required for city owned trees – if so, it will need to be paid prior to the release of the tree permit
4. the TCR must list all trees on site by species, diameter and health condition
5. the TCR must list all trees on adjacent sites if they have a critical root zone that extends onto the development site
6. If trees are to be removed, the TCR must clearly show where they are, and document the reason they cannot be retained
7. All retained trees must be shown and all retained trees within the area impacted by the development process must be protected as per City guidelines available at [Tree Protection Specification](#) or by searching [Ottawa.ca](#)
 - a. securities may be required for retained trees
 - b. the location of tree protection fencing must be shown on a plan
 - c. show the critical root zone of the retained trees if they are in/near disturbance areas
 - d. if excavation will occur within the critical root zone, please indicate the limits of excavation
8. the City encourages the retention of healthy trees; if possible, please seek opportunities for retention of trees that will contribute to the design/function of the site.
9. For more information on the process or help with tree retention options, contact Mark Richardson mark.richardson@ottawa.ca or on [City of Ottawa](#)

LP tree planting requirements:

For additional information on the following please contact Adam.Palmer@Ottawa.ca

Minimum Setbacks

- Maintain 1.5m from sidewalk or MUP/cycle track.
- Maintain 2.5m from curb
- Coniferous species require a minimum 4.5m setback from curb, sidewalk or MUP/cycle track/pathway.

- Maintain 7.5m between large growing trees, and 4m between small growing trees. Park or open space planting should consider 10m spacing.
- Adhere to Ottawa Hydro’s planting guidelines (species and setbacks) when planting around overhead primary conductors.

Tree specifications

- Minimum stock size: 50mm tree caliper for deciduous, 200cm height for coniferous.
- Maximize the use of large deciduous species wherever possible to maximize future canopy coverage
- Tree planting on city property shall be in accordance with the City of Ottawa’s Tree Planting Specification; and include watering and warranty as described in the specification (can be provided by Forestry Services).
- Plant native trees whenever possible
- No root barriers, dead-man anchor systems, or planters are permitted.
- No tree stakes unless necessary (and only 1 on the prevailing winds side of the tree)

Hard surface planting

- Curb style planter is highly recommended
- No grates are to be used and if guards are required, City of Ottawa standard (which can be provided) shall be used.
- Trees are to be planted at grade

Soil Volume

- Please ensure adequate soil volumes are met:

Tree Type/Size	Single Tree Soil Volume (m3)	Multiple Tree Soil Volume (m3/tree)
Ornamental	15	9
Columnar	15	9
Small	20	12
Medium	25	15
Large	30	18
Conifer	25	15

Please note that these soil volumes are not applicable in cases with Sensitive Marine Clay.

Sensitive Marine Clay

- Please follow the City’s 2017 Tree Planting in Sensitive Marine Clay guidelines

Fisher Heights Area Community Association:

1. Please see attached letters from D. Yonson and T. Sroka representing the interests of the CA.

Please refer to the links to [“Guide to preparing studies and plans”](#) and fees for general information. Additional information is available related to [building permits](#), [development charges](#), and the [Accessibility Design Standards](#). Be aware that other fees and permits may be required, outside of the development review process. You may obtain background drawings by contacting informationcentre@ottawa.ca.

These pre-con comments are valid for one year. If you submit a development application(s) after this time, you may be required to meet for another pre-consultation meeting and/or the submission

requirements may change. You are as well encouraged to contact us for a follow-up meeting if the plan/concept will be further refined.
Please contact me at Lisa.Stern@ottawa.ca or at 613-580-2424 extension 21108 if you have any questions.

Appendix B
Sanitary Servicing

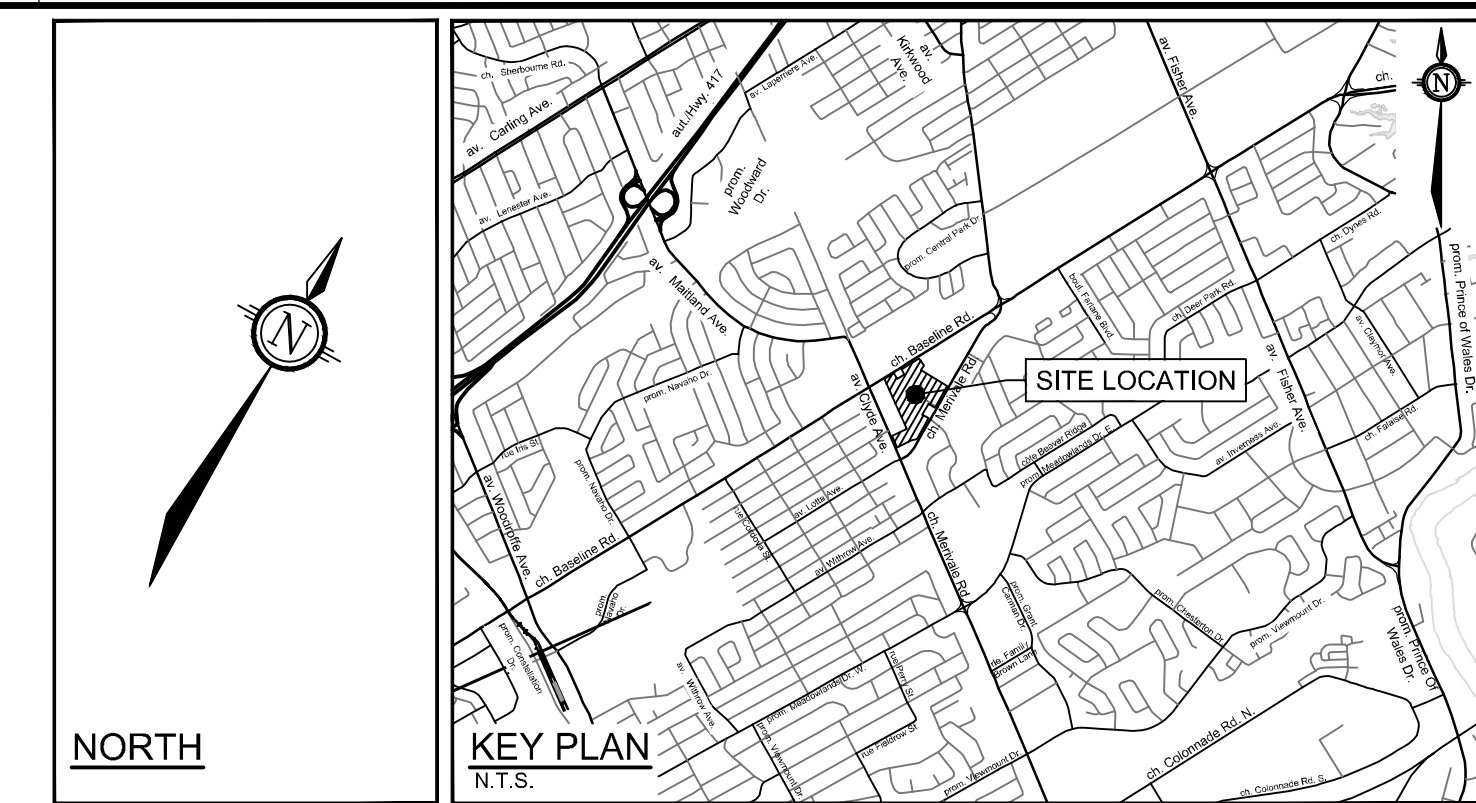

- LEGEND**
- PROPERTY LINE
 - PROPOSED SANITARY SEWER AND MANHOLE
 - DIRECTION OF FLOW
 - EXISTING SANITARY MANHOLE & SEWER
 - SANITARY SEWER DRAINAGE AREA BOUNDARY
- | | |
|-------|------------------------|
| 6,388 | DRAINAGE AREA (ha) |
| A-01 | AREA ID |
| 5 10 | POPULATION / NO. UNITS |

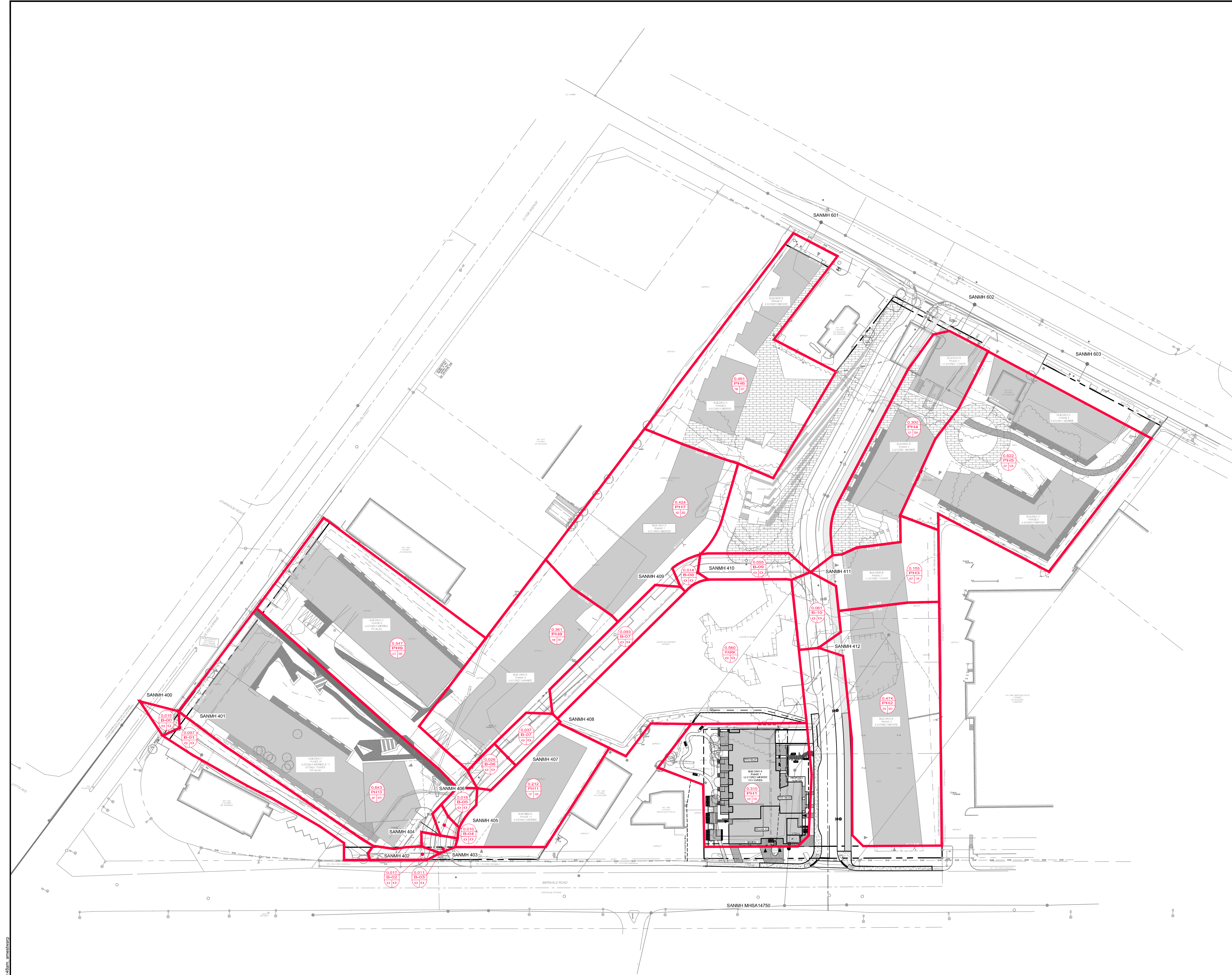

NOTE:
 THE POSITION OF ALL POLE LINES, CONDUITS,
 WATERMANS, SEWERS AND OTHER
 UNDERGROUND AND OVERGROUND UTILITIES AND
 STRUCTURES IS NOT NECESSARILY SHOWN ON
 THE CONTRACT DRAWINGS, AND WHERE SHOWN,
 THE ACCURACY OF THE POSITION OF SUCH
 UTILITIES AND STRUCTURES IS NOT GUARANTEED.
 BEFORE STARTING WORK, DETERMINE THE EXACT
 LOCATION OF ALL SUCH UTILITIES AND
 STRUCTURES AND ASSUME ALL LIABILITY FOR
 DAMAGE TO THEM.

CLARIDGE HOMES
 CLARIDGE HOMES
 505 PRESTON STREET,
 2ND FLOOR
 OTTAWA, ONTARIO
 K1S 4N7



**NOT FOR
 CONSTRUCTION**

No.	REVISION	DATE	BY
4.	REVISED PER CITY COMMENTS	SEPT 27/2024	GJM
3.	REISSUED PHASE 1 ONLY	OCT 27/2023	GJM
2.	REVISED AND ISSUED FOR CITY APPROVAL	DEC 09/2022	GJM

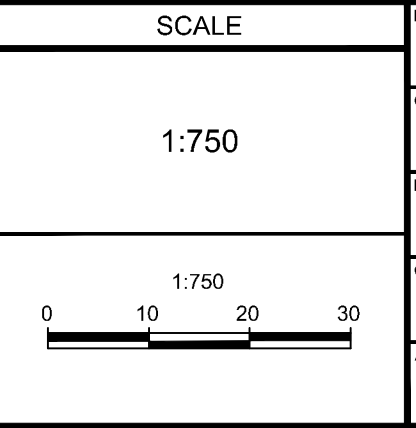

DESIGN	ARM
CHECKED	GJM
DRAWN	CJF/ARM
CHECKED	ARM
APPROVED	GJM

NOVATECH
 Engineers, Planners & Landscape Architects
 Suite 200, 240 Michael Copeland Drive
 Ottawa, Ontario, Canada K2M 1P6
 Telephone: (613) 254-9643
 Facsimile: (613) 254-5867
 Website: www.novatech-eng.com

LOCATION
1500 MERIVALE
 1500 MERIVALE, CITY OF OTTAWA

DRAWING NAME
SANITARY DRAINAGE PLAN

PROJECT No.	121009
REV #4	
DRAWING No.	121009-SAN

SANITARY SEWER DESIGN SHEET

Novatech Project #: 121009
 Project Name: 1500 Merivale Rd
 Date Prepared: 11/23/2022
 Date Revised: 8/21/2024
 Input By: Curtis Ferguson, E.I.T.
 Reviewed By: Anthony Mestwarp, P.Eng
 Drawing Reference: 121009 - SAN

Legend: PROJECT SPECIFIC INFO
 USER DESIGN INPUT
 CUMULATIVE CELL
 CALCULATED DESIGN CELL OUTPUT



LOCATION				DEMAND																	DESIGN CAPACITY										
STREET	AREA	FROM MH	TO MH	RESIDENTIAL FLOW										COMMERCIAL FLOW					EXTRAN. FLOW Q(e) (L/s)	TOTAL DESIGN FLOW Q(D) (L/s)	PROPOSED SEWER PIPE SIZING / DESIGN										
				STUDIO	1 BED	2 BED	3 BED	TOWN HOME	PARK AREA (ha)	POPULATION (in 1000's)	CUMULATIVE POPULATION (in 1000's)	PEAK FACTOR M	AVG POPULATION FLOW Q(q) (L/s)	PEAKED DESIGN POP FLOW Q(p) (L/s)	DRAINAGE AREA (ha.)	CUMULATIVE RES DRAINAGE AREA (ha.)	COMMERCIAL AREA (m)	CUMULATIVE COMMERCIAL AREA (m)			AVG DESIGN COMMERCIAL FLOW Q (c) (L/s)	COMMERCIAL PEAK FACTOR	PEAKED DESIGN ICI FLOW Q (C) (L/s)	PIPE LENGTH (m)	PIPE SIZE (mm) AND MATERIAL	PIPE ID ACTUAL (m)	ROUGH. (n)	DESIGN GRADE (%)	CAPACITY (L/s)	FULL FLOW VELOCITY (m/s)	Qpeak Design / Qcap
MERIVALE ROAD - PHASE 1																															
Phase 1	PH1	STUB	EX.14750	1	74	28	15	7	0.000	0.229	0.229	3.50	0.74	2.60	0.310	0.310	153.000	153.000	0.01	1.00	0.01	0.10	2.72	27.6	200 PVC	0.203	0.013	0.95	33.4	1.03	8.1%
CLYDE AVENUE - PHASES 2-3 & 7-11																															
Public Road	PH2	STUB	412	9	218	27	14	8	0.000	0.440	0.440	3.40	1.42	4.85	0.474	0.474	136.260	136.260	0.01	1.00	0.01	0.16	5.01	11.0	200 PVC	0.203	0.013	1.00	34.2	1.06	14.7%
Public Road	PARK	STUB	412	0	0	0	0	0	0.560	0.002	0.002	3.77	0.01	0.02	0.560	0.560	0.000	0.000	0.00	1.00	0.00	0.18	0.21	9.0	200 PVC	0.203	0.013	1.00	34.2	1.06	0.6%
Public Road	B-11	412	411	0	0	0	0	0	0.000	0.000	0.441	3.40	1.43	4.87	0.061	1.095	0.000	136.260	0.01	1.00	0.01	0.36	5.24	35.0	200 PVC	0.203	0.013	0.65	27.6	0.85	19.0%
Public Road	PH3	STUB	411	0	21	46	0	0	0.000	0.126	0.126	3.57	0.41	1.46	0.155	0.155	0.000	0.000	0.00	1.00	0.00	0.05	1.51	11.0	200 PVC	0.203	0.013	1.00	34.2	1.06	4.4%
Private Road	B-10	411	410	0	0	0	0	0	0.000	0.000	0.567	3.36	1.84	6.17	0.055	1.305	0.000	136.260	0.01	1.00	0.01	0.43	6.61	51.8	200 PVC	0.203	0.013	0.35	20.2	0.62	32.7%
Private Road	B-09	410	409	0	0	0	0	0	0.000	0.000	0.567	3.36	1.84	6.17	0.014	1.319	0.000	136.260	0.01	1.00	0.01	0.44	6.62	10.3	200 PVC	0.203	0.013	0.35	20.2	0.62	32.7%
Private Road	PH7	STUB	409	0	119	35	0	8	0.000	0.262	0.262	3.48	0.85	2.95	0.424	0.424	0.000	0.000	0.00	1.00	0.00	0.14	3.09	8.8	200 PVC	0.203	0.013	1.00	34.2	1.06	9.0%
Private Road	B-08	408	408	0	0	0	0	0	0.000	0.000	0.829	3.28	2.69	8.82	0.093	1.836	0.000	136.260	0.01	1.00	0.01	0.61	9.43	82.9	200 PVC	0.203	0.013	0.35	20.2	0.62	46.6%
Private Road	PH8	STUB	408	16	153	23	0	6	0.000	0.301	0.301	3.46	0.98	3.38	0.361	0.361	0.000	0.000	0.00	1.00	0.00	0.12	3.50	8.8	200 PVC	0.203	0.013	1.00	34.2	1.06	10.2%
Private Road	B-07	408	407	0	0	0	0	0	0.000	0.000	1.130	3.21	3.66	11.76	0.037	2.234	0.000	136.260	0.01	1.00	0.01	0.74	12.51	28.8	200 PVC	0.203	0.013	0.35	20.2	0.62	61.8%
Private Road	PH11	STUB	407	1	43	14	22	5	0.000	0.173	0.173	3.54	0.56	1.98	0.212	0.212	170.000	170.000	0.02	1.00	0.02	0.07	2.07	5.2	200 PVC	0.203	0.013	1.00	34.2	1.06	6.0%
Private Road	B-06	407	406	0	0	0	0	0	0.000	0.000	1.303	3.18	4.22	13.42	0.026	2.472	0.000	306.260	0.03	1.00	0.03	0.82	14.26	19.9	200 PVC	0.203	0.013	0.35	20.2	0.62	70.5%
Private Road	PH9	STUB	406	0	170	42	0	0	0.000	0.326	0.326	3.45	1.06	3.65	0.547	0.547	156.360	156.360	0.01	1.00	0.01	0.18	3.84	8.8	200 PVC	0.203	0.013	1.00	34.2	1.06	11.2%
Private Road	B-05	406	405	0	0	0	0	0	0.000	0.000	1.629	3.12	5.28	16.49	0.018	3.037	0.000	462.620	0.04	1.00	0.04	1.00	17.53	18.7	250 PVC	0.254	0.013	0.25	31.0	0.61	56.5%
Private Road	B-04	405	404	0	0	0	0	0	0.000	0.000	1.629	3.12	5.28	16.49	0.010	3.047	0.000	462.620	0.04	1.00	0.04	1.01	17.53	9.4	250 PVC	0.254	0.013	0.25	31.0	0.61	56.5%
Private Road	PH10	STUB	404	0	190	89	8	0	0.000	0.478	0.478	3.39	1.55	5.24	0.643	0.643	412.300	412.300	0.04	1.00	0.04	0.21	5.49	11.3	200 PVC	0.203	0.013	1.00	34.2	1.06	16.1%
Private Road	B-03	404	403	0	0	0	0	0	0.000	0.000	2.107	3.05	6.83	20.85	0.011	3.701	0.000	874.920	0.08	1.00	0.08	1.22	22.16	8.1	250 PVC	0.254	0.013	0.25	31.0	0.61	71.4%
Private Road	B-02	403	402	0	0	0	0	0	0.000	0.000	2.107	3.05	6.83	20.85	0.017	3.718	0.000	874.920	0.08	1.00	0.08	1.23	22.16	33.3	250 PVC	0.254	0.013	0.25	31.0	0.61	71.5%
Private Road	B-01	402	401	0	0	0	0	0	0.000	0.000	2.107	3.05	6.83	20.85	0.097	3.815	0.000	874.920	0.08	1.00	0.08	1.26	22.20	104.1	250 PVC	0.254	0.013	0.25	31.0	0.61	71.6%
Private Road	B-00	401	400	0	0	0	0	0	0.000	0.000	2.107	3.05	6.83	20.85	0.015	3.830	0.000	874.920	0.08	1.00	0.08	1.26	22.20	22.0	250 PVC	0.254	0.013	0.25	31.0	0.61	71.6%
BASELINE ROAD- PHASES 4-6																															
Phase 4	PH4	STUB	602	8	181	28	10	0	0.000	0.354	0.354	3.44	1.15	3.95	0.300	0.300	118.110	118.110	0.01	1.00	0.01	0.10	4.06	15.0	200 PVC	0.203	0.013	1.00	34.2	1.06	11.9%
Phase 5	PH5	STUB	603	10	170	65	12	0	0.000	0.426	0.426	3.41	1.38	4.70	0.622	0.622	101.950	101.950	0.01	1.00	0.01	0.21	4.92	8.8	200 PVC	0.203	0.013	1.00	34.2	1.06	14.4%
Phase 6	PH6	STUB	601	20	120	33	23	0	0.000	0.337	0.337	3.45	1.09	3.76	0.461	0.461	56.990	56.990	0.01	1.00	0.01	0.15	3.92	15.6	200 PVC	0.203	0.013	1.00	34.2	1.06	11.4%

DEMAND EQUATION
 Design Parameters:
 1. Q(D) = Q(p) + Q(c) + Q(e)
 2. Q(p) = (P x q x M x K / 86,400)
 3. q Avg capita = 280 L/per/day
 4. M = Harmon Formula (maximum of 4.0)
 5. K = 0.8
 6. Park flow is considered equivalent to a single unit / ha
 Park Demand = 1 Single Unit Equivalent / Park ha
 7. Q(e) = 0.33 L/sec/ha

Definitions:
 Q(D) = Peak Design Flow (L/sec)
 Q(e) = Extraneous Flow (L/sec)
 Q(p) = Population Flow (L/sec)
 K = Harmon Correction Factor
 P = Residential Population

Studio	1 Bed	2 Bed	3 Bed	Townhome	Single
1.4	1.4	2.1	3.1	2.7	3.4

Q(c) = Industrial / Commercial / Institutional Flow (L/sec)
 Commercial Design = 75 L/9.3m2/day
 Commercial Design = 1.0 1.5 * ICI Peak = 1.0 Default, 1.5 if ICI in contributing area is >20% (design only)

CAPACITY EQUATION
 $Q_{full} = (1/n) A R^{2/3} S_o^{1/2}$

Where : Q full = Capacity (L/s)

n = Manning coefficient of roughness (0.013)
 A = Flow area (m²)
 R = Wetted perimeter (m)
 S_o = Pipe Slope/gradient

From: Tousignant, Eric <Eric.Tousignant@ottawa.ca>
Sent: Thursday, August 11, 2022 10:03 AM
To: Anthony Mestwarp <a.mestwarp@novatech-eng.com>
Cc: Greg MacDonald <g.Macdonald@novatech-eng.com>; Curtis Ferguson <c.ferguson@novatech-eng.com>
Subject: RE: 121009 - 1500 Merivale

Hi Anthony

I don't have concerns with the proposed 2.6 L/s for phase 1 going to the existing Merivale Road outlet.

Regards
Eric

Eric Tousignant, P.Eng.

Senior Water Resources Engineer/ Ingénieur principal en ressources hydriques
Infrastructure and Water Services / services d'infrastructure et d'eau
613-580-2424 ext 25129

Vacation Notice : Note that I will be away on vacation from July 25th to August 12, but will be checking emails periodically to forward them to appropriate staff.

From: Anthony Mestwarp <a.mestwarp@novatech-eng.com>
Sent: August 08, 2022 11:56 AM
To: Tousignant, Eric <Eric.Tousignant@ottawa.ca>
Cc: Greg MacDonald <g.Macdonald@novatech-eng.com>; Curtis Ferguson <c.ferguson@novatech-eng.com>
Subject: 121009 - 1500 Merivale

CAUTION: This email originated from an External Sender. Please do not click links or open attachments unless you recognize the source.
ATTENTION : Ce courriel provient d'un expéditeur externe. Ne cliquez sur aucun lien et n'ouvrez pas de pièce jointe, excepté si vous connaissez l'expéditeur.

Hi Eric,

Following up after our meeting, the Phase 1 statistics are as follows:

68 – 1 Bedroom Units
25 – 2 Bedroom Units
15 – 3 Bedroom Units
7 – Ground floor townhome units
168.62m² of commercial area
0.48ha of drainage area

- Total population of **213** people
- Total design flow of **2.6L/s**

Please let us know if you require any further information to review the phase 1 flows.

Thanks,

Anthony Mestwarp, P.Eng., Project Engineer | Land Development Engineering

NOVATECH Engineers, Planners & Landscape Architects

240 Michael Cowpland Drive, Suite 200, Ottawa, ON, K2M 1P6 | Tel: 613.254.9643 Ext. 216 | Fax: 613.254.5867

The information contained in this email message is confidential and is for exclusive use of the addressee.

This e-mail originates from the City of Ottawa e-mail system. Any distribution, use or copying of this e-mail or the information it contains by other than the intended recipient(s) is unauthorized. Thank you.

Le présent courriel a été expédié par le système de courriels de la Ville d'Ottawa. Toute distribution, utilisation ou reproduction du courriel ou des renseignements qui s'y trouvent par une personne autre que son destinataire prévu est interdite. Je vous remercie de votre collaboration.

From: Tousignant, Eric <Eric.Tousignant@ottawa.ca>

Sent: Wednesday, July 20, 2022 2:32 PM

To: Anthony Mestwarp <a.mestwarp@novatech-eng.com>

Cc: Curtis Ferguson <c.ferguson@novatech-eng.com>; Kuruvilla, Santhosh <Santhosh.Kuruvilla@ottawa.ca>; Greg MacDonald <g.Macdonald@novatech-eng.com>

Subject: RE: 121009 - Sanitary Flows

Hi Anthony

The Merivale outlet is going through Granton where there is flooding history. Our preliminary analysis showed that we could take 18 L/s per second, but that was before we reached flooding levels and there is no appetite at the city to take such a risk. Also, Novatach requested 22 L/s in another email and that would have been problematic. The city just spent significant funds to solve the flooding issues in this area following the 2004 event, therefore the community would not like the idea of us taking this system beyond its capacity.

Eric

From: Anthony Mestwarp <a.mestwarp@novatech-eng.com>

Sent: July 20, 2022 1:46 PM

To: Tousignant, Eric <Eric.Tousignant@ottawa.ca>

Cc: Curtis Ferguson <c.ferguson@novatech-eng.com>; Kuruvilla, Santhosh <Santhosh.Kuruvilla@ottawa.ca>; Greg MacDonald <g.Macdonald@novatech-eng.com>

Subject: RE: 121009 - Sanitary Flows

CAUTION: This email originated from an External Sender. Please do not click links or open attachments unless you recognize the source.

ATTENTION : Ce courriel provient d'un expéditeur externe. Ne cliquez sur aucun lien et n'ouvrez pas de pièce jointe, excepté si vous connaissez l'expéditeur.

Hi Eric,

Can you please elaborate? I understand from previous correspondence that there was some capacity available in the Clyde system (correspondence attached). Are you saying that the previously noted capacity has been allocated to other developments in the area? If so, is there any capacity left available for the 1500 Merivale development, or will the development be unable to proceed until the extension is completed.

I would appreciate any clarification you can provide, so that we can accurately relay the information to the client.

Thanks,

Anthony Mestwarp, P.Eng., Project Engineer | Land Development Engineering

NOVATECH Engineers, Planners & Landscape Architects

240 Michael Cowpland Drive, Suite 200, Ottawa, ON, K2M 1P6 | Tel: 613.254.9643 Ext. 216 | Fax: 613.254.5867

The information contained in this email message is confidential and is for exclusive use of the addressee.

From: Tousignant, Eric <Eric.Tousignant@ottawa.ca>

Sent: Wednesday, July 20, 2022 1:13 PM

To: Anthony Mestwarp <a.mestwarp@novatech-eng.com>

Cc: Curtis Ferguson <c.ferguson@novatech-eng.com>; Kuruville, Santhosh <Santhosh.Kuruville@ottawa.ca>; Greg MacDonald <g.Macdonald@novatech-eng.com>

Subject: RE: 121009 - Sanitary Flows

Hi Anthony

There is no capacity in the Clyde and Merivale sewers (the one that drains westward via Granton). This is why we have added an extension of the Merivale Sanitary sewer (from Cleto to Baseline) in the IMP.

Eric

Eric Tousignant, P.Eng.

Senior Water Resources Engineer/ Ingénieur principal en ressources hydriques

Infrastructure and Water Services / services d'infrastructure et d'eau

613-580-2424 ext 25129

Vacation Notice : Note that I will be away on vacation from July 25th to August 12, but will be checking emails periodically to forward them to appropriate staff.

From: Anthony Mestwarp <a.mestwarp@novatech-eng.com>

Sent: July 20, 2022 12:15 PM

To: Tousignant, Eric <Eric.Tousignant@ottawa.ca>

Cc: Curtis Ferguson <c.ferguson@novatech-eng.com>; Kuruville, Santhosh <Santhosh.Kuruville@ottawa.ca>; Greg MacDonald <g.Macdonald@novatech-eng.com>

Subject: RE: 121009 - Sanitary Flows

CAUTION: This email originated from an External Sender. Please do not click links or open attachments unless you recognize the source.

ATTENTION : Ce courriel provient d'un expéditeur externe. Ne cliquez sur aucun lien et n'ouvrez pas de pièce jointe, excepté si vous connaissez l'expéditeur.

Hi Eric,

Thanks for getting back to me. Are there any issues with the proposed flows to the Clyde and Merivale connections?

The first 3 phases of the site are proposed to serviced by the Merivale connection. Depending on the timing of the Baseline works we may need to adjust the buildout (phasing of the future development), phases 4, 5, and 6 are serviced from Baseline. If timing is an issue we can coordinate with the client to assess constructing the phases serviced by the Clyde connection (phases 7-10) prior to Baseline. Can you please let us know once timing becomes available.

Thanks,

Anthony Mestwarp, P.Eng., Project Engineer | Land Development Engineering

NOVATECH Engineers, Planners & Landscape Architects

240 Michael Cowpland Drive, Suite 200, Ottawa, ON, K2M 1P6 | Tel: 613.254.9643 Ext. 216 | Fax: 613.254.5867

The information contained in this email message is confidential and is for exclusive use of the addressee.

From: Tousignant, Eric <Eric.Tousignant@ottawa.ca>

Sent: Friday, July 15, 2022 3:23 PM

To: Anthony Mestwarp <a.mestwarp@novatech-eng.com>

Cc: Curtis Ferguson <c.ferguson@novatech-eng.com>; Kuruvilla, Santhosh <Santhosh.Kuruvilla@ottawa.ca>; Greg MacDonald <g.Macdonald@novatech-eng.com>

Subject: RE: 121009 - Sanitary Flows

Hi Anthony

Yes we did. At this time, we only have some capacity in the baseline system. As such, we have recommended an extension northward to the Merrivale sanitary sewer and this has been added to the current Infrastructure Master Plan. I don't have any information on the timing of this work though.

Eric

From: Anthony Mestwarp <a.mestwarp@novatech-eng.com>

Sent: July 15, 2022 3:13 PM

To: Tousignant, Eric <Eric.Tousignant@ottawa.ca>

Cc: Curtis Ferguson <c.ferguson@novatech-eng.com>; Kuruvilla, Santhosh <Santhosh.Kuruvilla@ottawa.ca>; Greg MacDonald <g.Macdonald@novatech-eng.com>

Subject: RE: 121009 - Sanitary Flows

CAUTION: This email originated from an External Sender. Please do not click links or open attachments unless you recognize the source.

ATTENTION : Ce courriel provient d'un expéditeur externe. Ne cliquez sur aucun lien et n'ouvrez pas de pièce jointe, excepté si vous connaissez l'expéditeur.

Hi Eric,

I hope you are doing well. Have you had a chance to review the proposed flows for the 1500 Merivale site, that GMAC previously sent?

They are as follows:

Presently:

Merivale: 8.98L/s

Clyde: 15.11 L/s

Baseline: 15.97L/s

Please let us know if you require any further information.

Thanks,

Anthony Mestwarp, P.Eng., Project Engineer | Land Development Engineering

NOVATECH Engineers, Planners & Landscape Architects

240 Michael Cowpland Drive, Suite 200, Ottawa, ON, K2M 1P6 | Tel: 613.254.9643 Ext. 216 | Fax: 613.254.5867

The information contained in this email message is confidential and is for exclusive use of the addressee.

From: Greg MacDonald <g.Macdonald@novatech-eng.com>

Sent: Monday, June 13, 2022 2:16 PM

To: santhosh.kuruville@ottawa.ca

Cc: Tousignant, Eric <Eric.Tousignant@ottawa.ca>; Anthony Mestwarp <a.mestwarp@novatech-eng.com>; Curtis Ferguson <c.ferguson@novatech-eng.com>

Subject: FW: 121009 - Sanitary Flows

Hi Santhosh,

Per your request to Anthony please see below and attached for sanitary flows.

I am also attaching the General Plans of Services and Cross Section of the loop road which shows the placement of utilities in a 14.5 m roadway cross-section. Can you please provide your comments/concurrence on this roadway cross section.

Thanks.

Greg MacDonald, P. Eng.

Director, Land Development and Public Sector Infrastructure

NOVATECH Engineers, Planners & Landscape Architects

240 Michael Cowpland Drive, Suite 200, Ottawa, ON, K2M 1P6 | Tel: 613.254.9643 x279 | Cell: 613.890.9705 | Fax: 613.254.5867

The information contained in this email message is confidential and is for exclusive use of the addressee

From: Anthony Mestwarp <a.mestwarp@novatech-eng.com>

Sent: Wednesday, June 8, 2022 1:28 PM

To: Greg MacDonald <g.Macdonald@novatech-eng.com>

Cc: Curtis Ferguson <c.ferguson@novatech-eng.com>

Subject: 121009 - Sanitary Flows

Hi GMAC,

As previously discussed.

Find attached the sanitary flow calculations for the current 1500 Merivale layout. We should get this out for coordination with the City as soon as possible to determine if the currently proposed layout is feasible.

Presently:

Merivale: 8.98L/s

Clyde: 15.11 L/s

Baseline: 15.97L/s

Please let me know if you want me to reach out to the city directly to keep things moving forward.

Regards,

Anthony Mestwarp, P.Eng., Project Engineer | Land Development Engineering

NOVATECH Engineers, Planners & Landscape Architects

240 Michael Cowpland Drive, Suite 200, Ottawa, ON, K2M 1P6 | Tel: 613.254.9643 Ext. 216 | Fax: 613.254.5867

The information contained in this email message is confidential and is for exclusive use of the addressee.

This e-mail originates from the City of Ottawa e-mail system. Any distribution, use or copying of this e-mail or the information it contains by other than the intended recipient(s) is unauthorized. Thank you.

Le présent courriel a été expédié par le système de courriels de la Ville d'Ottawa. Toute distribution, utilisation ou reproduction du courriel ou des renseignements qui s'y trouvent par une personne autre que son destinataire prévu est interdite. Je vous remercie de votre collaboration.

From: Tousignant, Eric <Eric.Tousignant@ottawa.ca>
Sent: Thursday, January 28, 2021 9:11 AM
To: Greg MacDonald <g.Macdonald@novatech-eng.com>
Cc: Surprenant, Eric <Eric.Surprenant@ottawa.ca>
Subject: RE: 1500 Merivale Road (former CJOH Site)

Hi Greg

We just finished running a series of scenarios through our Flood Risk Profile model and have come to the following conclusions.

- We looked at various outlets and added either the full 36 L/s flow or half of it (18 L/s) assuming that a flow spilt scenario would be possible. The four outlets are shown below and are 1 (Merivale Road draining through Parkwood Hills), 2 (Baseline, draining west to the Woodroffe Collector), 3 (Merivale, drainage west on Granton then South to the Lynwood Collector via Viewmount) and 4 (Merivale Draining South to the Lynwood Collector).

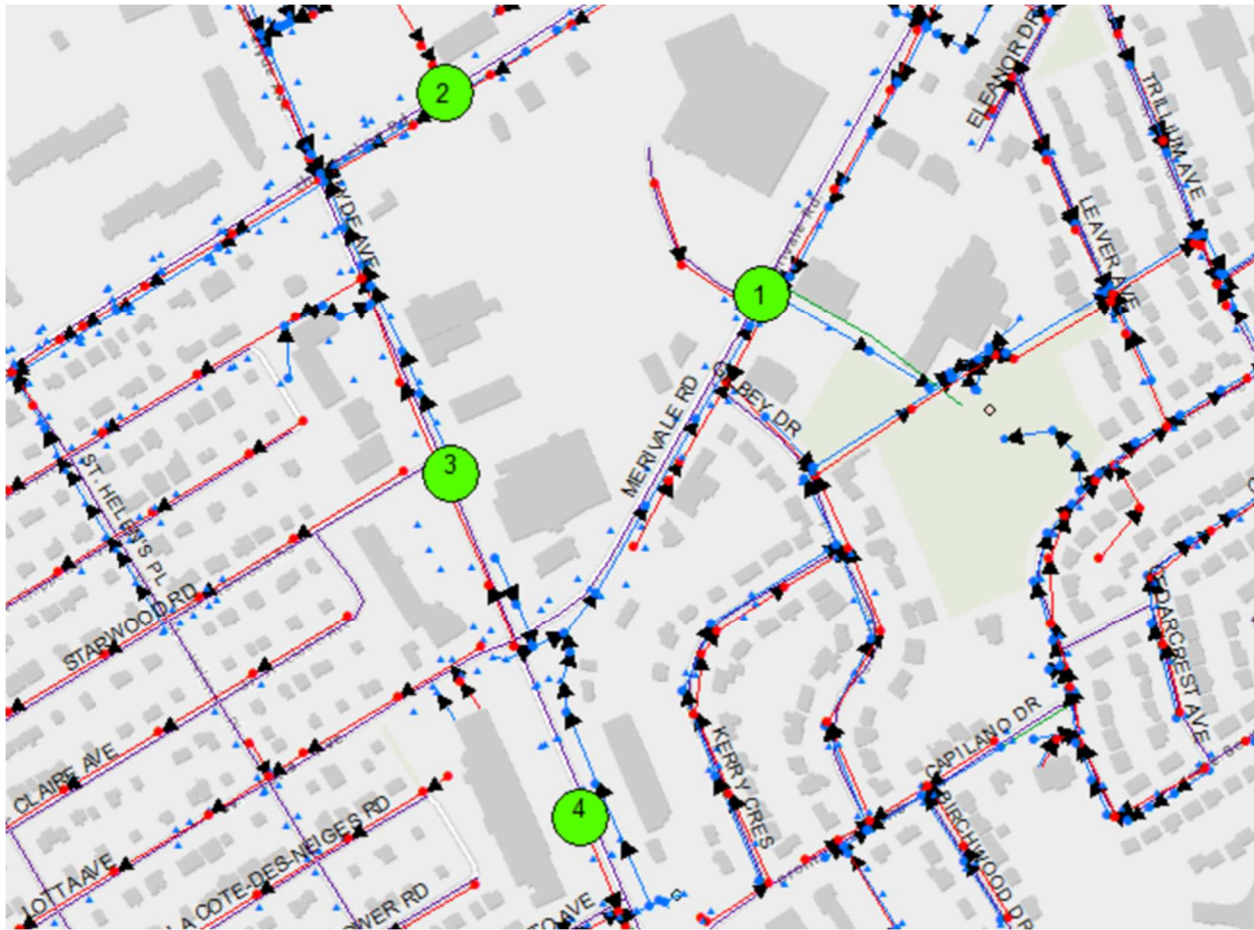

- Outlet #1 is the natural drainage point for this sanitary system, however the Parkwood Hills system was never designed for such a large domestic input at it's upstream end. When we add the 36 L/s flow to it, we get significant surcharge that reaches basement elevation and even the ground. See image below. This system does not work for 36 L/s or even 18 L/s.

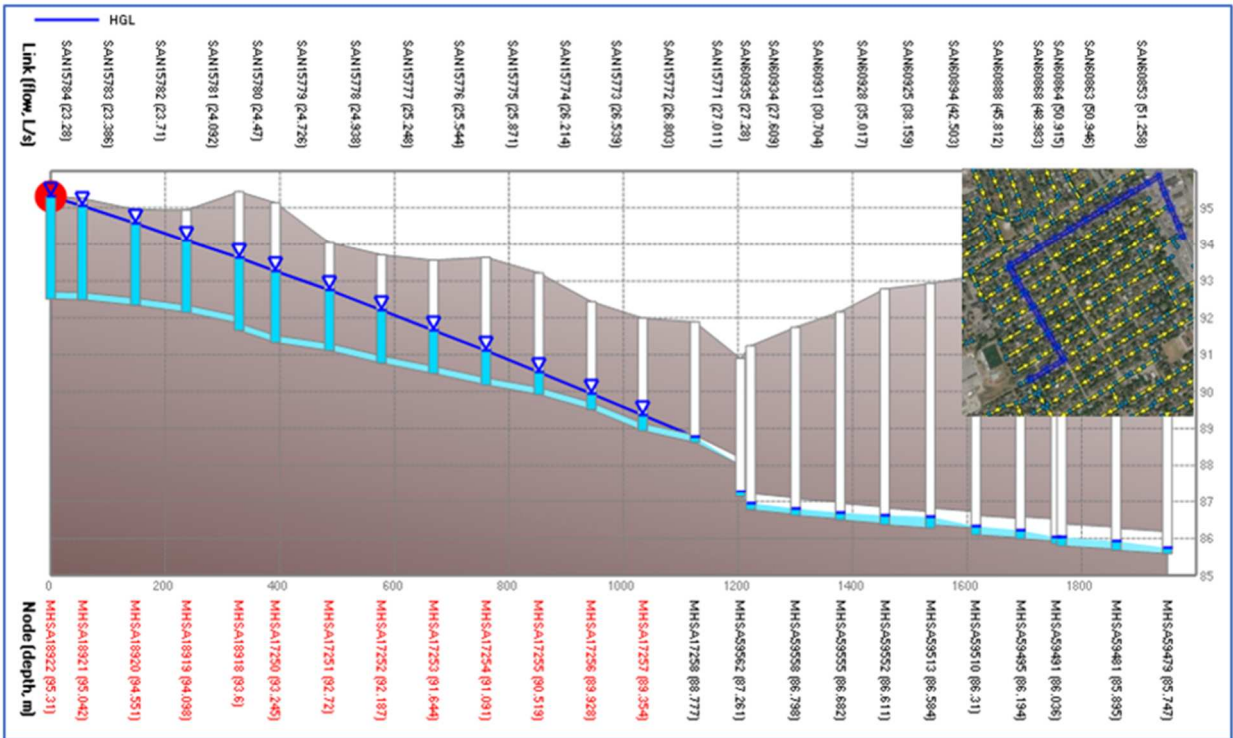

- The last outlet (#4) is on Merivale, South of Clyde. This system continues down Merivale and goes to the Lynwood Collector. It does have Capacity for the 36 L/s, except that the upper pipes become surcharged. Pumping to the system would be required with a forcemain approximately 700 m long (private forcemain in city ROW using a permit of occupation) so that it can discharge downstream of the surcharged pipe sections. Alternatively, the flow could be split between this system and the system going west along Granton. Gravity connections to these systems may be feasible pending further analysis,

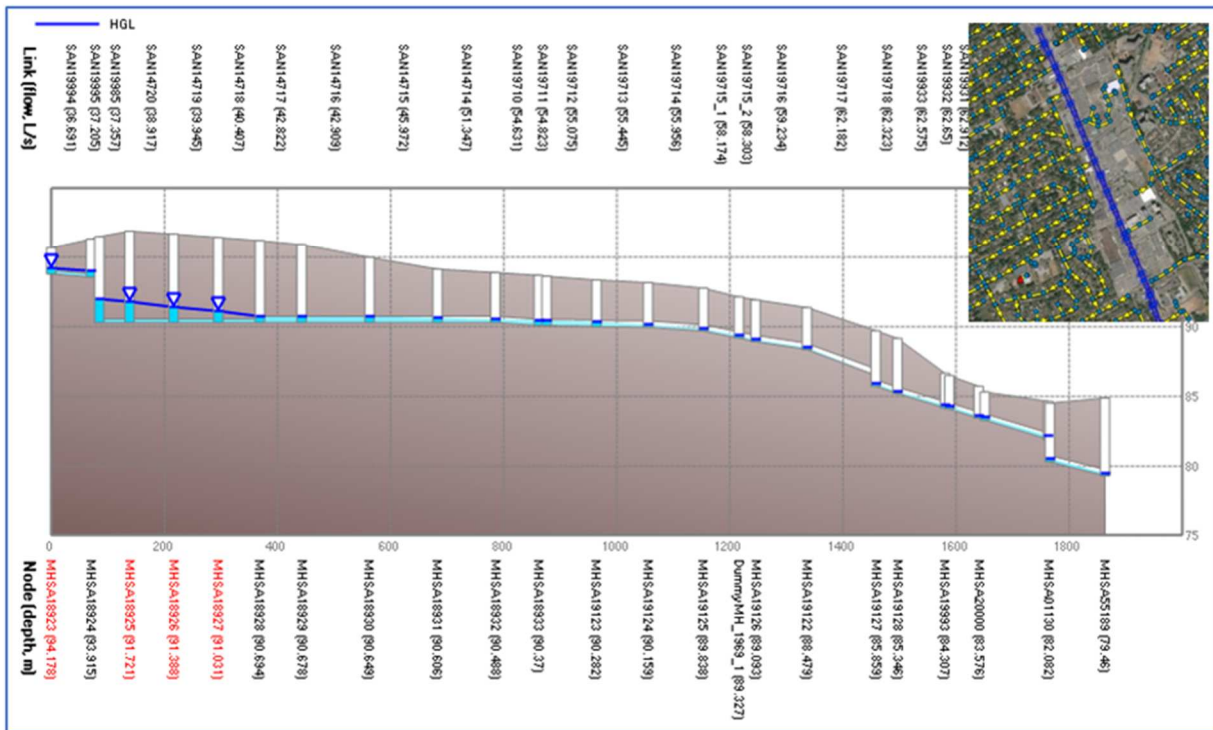

I hope this help in hour analysis Greg.
Contact me if you have any questions.

Eric

Eric Tousignant, P.Eng.

Senior Water Resources Engineer
Infrastructure Services
613-580-2424 ext 25129

From: Greg MacDonald <g.Macdonald@novatech-eng.com>

Sent: January 20, 2021 11:37 AM

To: Tousignant, Eric <Eric.Tousignant@ottawa.ca>

Cc: Surprenant, Eric <Eric.Surprenant@ottawa.ca>

Subject: 1500 Merivale Road (former CJOH Site)

CAUTION: This email originated from an External Sender. Please do not click links or open attachments unless you recognize the source.

ATTENTION : Ce courriel provient d'un expéditeur externe. Ne cliquez sur aucun lien et n'ouvrez pas de pièce jointe, excepté si vous connaissez l'expéditeur.

The estimated peak sanitary flow for 1500 Merivale Road (former CJOH site), based on 2000 residential units and site area of 0.58 ha. is 36 L/sec.

Thanks.

Greg MacDonald, P. Eng.

Director, Land Development and Public Sector Infrastructure

NOVATECH Engineers, Planners & Landscape Architects

240 Michael Cowpland Drive, Suite 200, Ottawa, ON, K2M 1P6 | Tel: 613.254.9643 x279 | Cell: 613.890.9705 | Fax: 613.254.5867

The information contained in this email message is confidential and is for exclusive use of the addressee

From: Tousignant, Eric <Eric.Tousignant@ottawa.ca>
Sent: Thursday, January 14, 2021 1:08 PM
To: Greg MacDonald <g.Macdonald@novatech-eng.com>
Subject: RE: 861 Clyde Avenue

Hi Greg

I will have to go back and check this. I recall looking into it and the property at the Southeast Corner on Baseline and Merivale actually drains into Parkwood hills and does not go west along Baseline. I had discussions with Eric Surprenant about that in December and was waiting for sanitary flow estimates from the property in question. Do you have the estimated sanitary flows? It just a question to adding this flow to our new floor risk profile model.

As for 861 Clyde, I never heard back from Construction Services and I have contacted them again. I will be pushing them more this time. From what I recall, you were looking at a significant flow contribution and I am sure that it was not accounted for at the time of the sewer upgrade design. Again, in this case, I may simply go the route of adding the flows to the flood risk profile model to see the downstream impact. Do you have the flow estimate for this property?

Eric

Eric Tousignant, P.Eng.

Senior Water Resources Engineer
Infrastructure Services
613-580-2424 ext 25129

From: Greg MacDonald <g.Macdonald@novatech-eng.com>
Sent: January 07, 2021 9:30 AM
To: Tousignant, Eric <Eric.Tousignant@ottawa.ca>
Subject: RE: 861 Clyde Avenue

CAUTION: This email originated from an External Sender. Please do not click links or open attachments unless you recognize the source.

ATTENTION : Ce courriel provient d'un expéditeur externe. Ne cliquez sur aucun lien et n'ouvrez pas de pièce jointe, excepté si vous connaissez l'expéditeur.

Hi Eric,

Hope you enjoyed the holidays. I am just following up on two projects:

1. 861 Clyde. I understand that City is replacing sewers on Carling Avenue and want to make sure they are sized for the proposed development at 861 Clyde Avenue. A site plan submission was made before Christmas.
2. The property at southeast corner of Baseline and Merivale, bounded on south by Clyde. I believe your people were looking into downstream infrastructure on Baseline west of Merivale.

Thanks and Happy New Year!

Greg MacDonald, P. Eng.

Director, Land Development and Public Sector Infrastructure

NOVATECH Engineers, Planners & Landscape Architects

240 Michael Cowpland Drive, Suite 200, Ottawa, ON, K2M 1P6 | Tel: 613.254.9643 x279 | Cell: 613.890.9705 | Fax: 613.254.5867

The information contained in this email message is confidential and is for exclusive use of the addressee

From: Tousignant, Eric <Eric.Tousignant@ottawa.ca>
Sent: Wednesday, June 17, 2020 11:44 AM
To: Greg MacDonald <g.Macdonald@novatech-eng.com>
Subject: RE: 861 Clyde Avenue

Hi Greg

I did not forget about you 😊 I have forward your information to constructions services and they are looking at the impact of the future flows on their design.

I will let know more when I hear back from them.

Eric

From: Greg MacDonald <g.Macdonald@novatech-eng.com>
Sent: June 12, 2020 9:50 AM
To: Tousignant, Eric <Eric.Tousignant@ottawa.ca>
Subject: RE: 861 Clyde Avenue

CAUTION: This email originated from an External Sender. Please do not click links or open attachments unless you recognize the source.

ATTENTION : Ce courriel provient d'un expéditeur externe. Ne cliquez sur aucun lien et n'ouvrez pas de pièce jointe, excepté si vous connaissez l'expéditeur.

For 2000 units 36 L/sec.

Greg MacDonald, P. Eng.

Director, Land Development and Public Sector Infrastructure

NOVATECH Engineers, Planners & Landscape Architects

240 Michael Cowpland Drive, Suite 200, Ottawa, ON, K2M 1P6 | Tel: 613.254.9643 x279 | Cell: 613.890.9705 | Fax: 613.254.5867

The information contained in this email message is confidential and is for exclusive use of the addressee

From: Tousignant, Eric <Eric.Tousignant@ottawa.ca>
Sent: Friday, June 12, 2020 9:44 AM
To: Greg MacDonald <g.Macdonald@novatech-eng.com>
Subject: RE: 861 Clyde Avenue

Hi Greg

I doubt that such a change in land use and density would have been accounted for in a local rehab project. Regardless I have forwarded your question to the engineer looking after this rehab project as well as those working on the Infrastructure master plan. In the meantime, can you give me an estimate of your peak flows? We can add that to our flood risk profile PCSWMM model to see the impact.

Eric

Eric Tousignant, P.Eng.

Senior Water Resources Engineer

Infrastructure Services

613-580-2424 ext 25129

From: Greg MacDonald <g.Macdonald@novatech-eng.com>

Sent: June 11, 2020 5:45 PM

To: Tousignant, Eric <Eric.Tousignant@ottawa.ca>

Subject: 861 Clyde Avenue

CAUTION: This email originated from an External Sender. Please do not click links or open attachments unless you recognize the source.

ATTENTION : Ce courriel provient d'un expéditeur externe. Ne cliquez sur aucun lien et n'ouvrez pas de pièce jointe, excepté si vous connaissez l'expéditeur.

Hi Eric,

Hope all is well. Our client just purchased the property at 861 Clyde Avenue (East side of Clyde directly adjacent to 417) and they are planning an extensive development of up to 2000 units, 6 or seven high rise buildings. I understand that JL Richards is designing the upgrade of sanitary sewer on Carling from Churchill to the Cave Creek Collector on Carling at Kirkwood. We just want to ensure that our site will be accounted for at the density I provided. Can you please advise?

Thanks.

Greg MacDonald, P. Eng.

Director, Land Development and Public Sector Infrastructure

NOVATECH Engineers, Planners & Landscape Architects

240 Michael Cowpland Drive, Suite 200, Ottawa, ON, K2M 1P6 | Tel: 613.254.9643 x279 | Cell: 613.890.9705 | Fax: 613.254.5867

The information contained in this email message is confidential and is for exclusive use of the addressee

,

This e-mail originates from the City of Ottawa e-mail system. Any distribution, use or copying of this e-mail or the information it contains by other than the intended recipient(s) is unauthorized. Thank you.

Le présent courriel a été expédié par le système de courriels de la Ville d'Ottawa. Toute distribution, utilisation ou reproduction du courriel ou des renseignements qui s'y trouvent par une personne autre que son destinataire prévu est

Appendix C
Storm Servicing

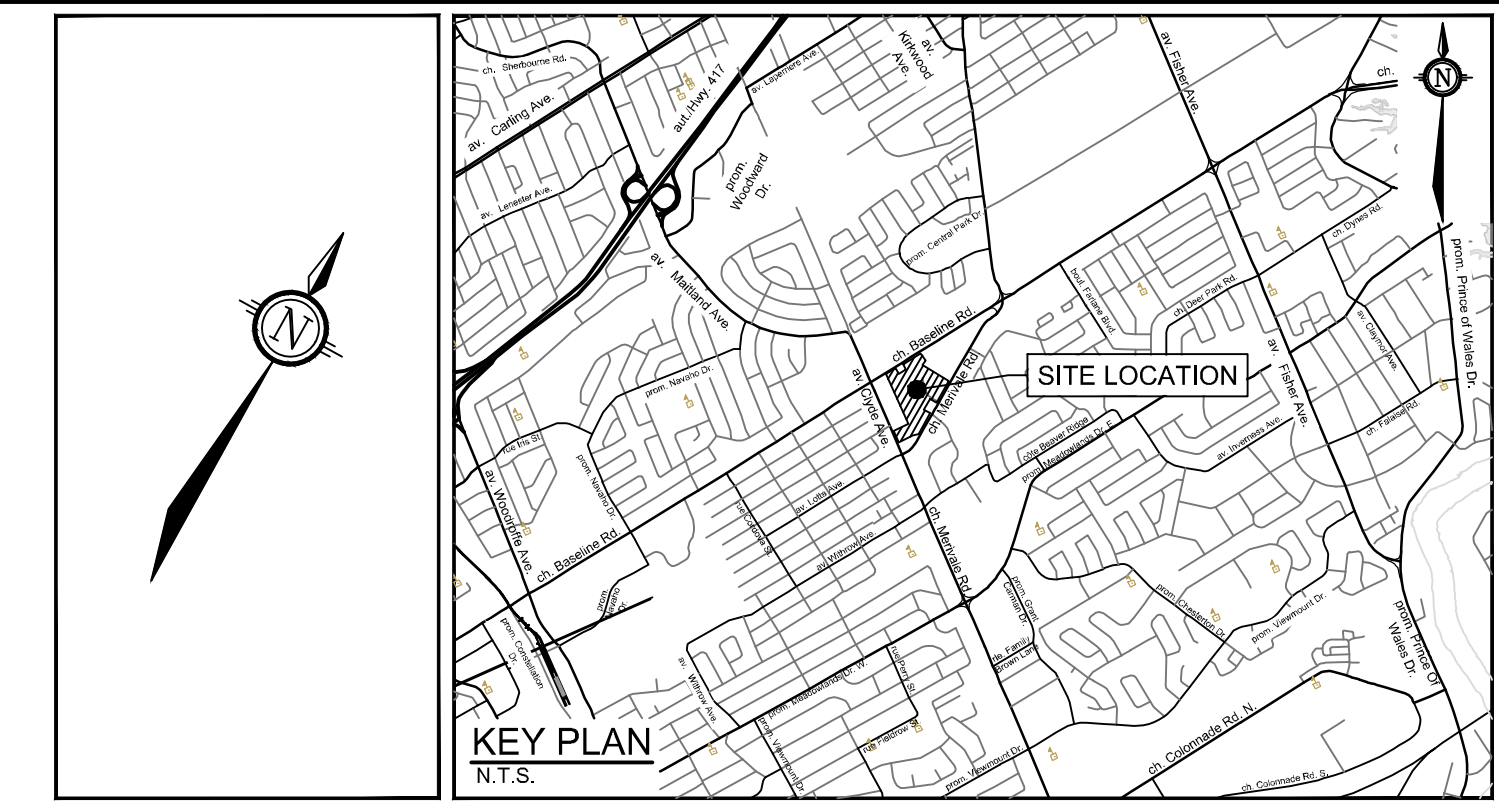

LEGEND

- PROPERTY LINE
- ⊖ PROPOSED STORM SEWER AND MANHOLE
- DIRECTION OF FLOW
- PROPOSED CATCHBASIN MANHOLE
- PROPOSED CATCHBASIN
- EXISTING STORM MANHOLE & SEWER
- EXISTING CATCHBASIN
- STORM SEWER DRAINAGE AREA BOUNDARY

STM MH: ○
 CB: □

○ DRAINAGE AREA (ha)
 A: 1.8
 0.78 DRAINAGE AREA ID
 0.78 RUNOFF COEFFICIENT



NOTE:
 THE POSITION OF ALL POLE LINES, CONDUITS,
 WATERMANS, SEWERS AND OTHER
 UNDERGROUND AND OVERGROUND UTILITIES AND
 STRUCTURES IS NOT NECESSARILY SHOWN ON
 THE CONTRACT DRAWINGS, AND WHERE SHOWN,
 THE ACCURACY OF THE POSITION OF SUCH
 UTILITIES AND STRUCTURES IS NOT GUARANTEED.
 BEFORE STARTING WORK, DETERMINE THE EXACT
 LOCATION OF ALL SUCH UTILITIES AND
 STRUCTURES AND ASSUME ALL LIABILITY FOR
 DAMAGE TO THEM.

CLARIDGE HOMES
 505 PRESTON STREET,
 2ND FLOOR
 OTTAWA, ONTARIO
 K1S 4N7



**NOT FOR
 CONSTRUCTION**

No.	REVISION	DATE	BY
4.	REVISED PER CITY COMMENTS	SEPT 27/2024	GJM
3.	REISSUED PHASE 1 ONLY	OCT 27/2023	GJM
2.	REVISED AND ISSUED FOR CITY APPROVAL	DEC 09/2022	GJM
1.	ISSUED FOR SITE PLAN SUBMISSION	SEPT 03/2021	JAG

SCALE

1:750

0 10 20 30

DESIGN	ARM
CHECKED	GJM
DRAWN	CJF/ARM
CHECKED	ARM
APPROVED	GJM



LOCATION
 1500 MERIVALE
 1500 MERIVALE, CITY OF OTTAWA

DRAWING NAME
**STORM DRAINAGE AREA
 PLAN**

PROJECT No.	121009
REV	REV #4
DRAWING No.	SWM

STORM SEWER DESIGN SHEET

Novatech Project #: 121009
 Project Name: 15000 Merivale Road - Claridge Inc.
 Date Prepared: 12/21/2021
 Date Revised: 11/18/2022
 Date Revised: 3/21/2024
 Date Revised: 7/31/2024
 Input By: Curtis Ferguson, E.I.T.
 Reviewed By: Anthony Mestwarp, P.Eng
 Drawing Reference: 121009-STM

Legend:
 PROJECT SPECIFIC INFO
 USER DESIGN INPUT
 CUMILATIVE CELL
 CALCULATED DESIGN CELL OUTPUT
 USER AS-BUILT INPUT

LOCATION		DEMAND										CAPACITY																
		AREA					FLOW					PROPOSED SEWER PIPE SIZING / DESIGN																
From MH	To MH	Area ID	Hardscape	Landscaping	Parkland	Total Area	Weighted Runoff Coefficient	Indivi 2.78 AR	Accum 2.78 AR	Time of Concentration (min.)	Rain Intensity (mm/hr)			Peak Flow (L/s)	TOTAL UNRESTRICTED PEAK FLOW (QDesign) (L/s)	PIPE PROPERTIES					CAPACITY (L/s)	FULL FLOW VELOCITY (m/s)	TIME OF FLOW (min.)	QPEAK DESIGN / QFULL (%)				
			0.90	0.20	0.40	(ha)					2yr	5yr	100yr			LENGTH (m)	SIZE / MATERIAL (mm / type)	ID ACTUAL (m)	ROUGHNESS	DESIGN GRADE (%)								
STREET 1 - PUBLIC SEWER RUN (100 SERIES)																												
109	108	A-06A	0.042	0.000		0.042	0.90	0.11																				
			0.000																									
		A-06B	0.031	0.009		0.039	0.74	0.08																				
			0.000																									
A-05A	0.078	0.000	0.078	0.90	0.19	0.00	0.00	0.00	10.00	76.81	0.00	0.00	10.00	40.20	40.2	78.1	300 PVC	0.3048	0.013	3.00	174.7	2.39	0.54	23.0%				
																											0.000	0.054
A-05B	0.054	0.015	0.068	0.75	0.00	0.00	0.00	0.00	10.54	74.78	0.00	0.00	10.54	39.14	39.1	13.7	300 PVC	0.3048	0.013	3.00	174.7	2.39	0.10	22.4%				
																											0.000	0.000
108	107		0.000	0.000	0.000	0.000	0.00	0.00	0.00	10.54	74.78	0.00	0.00	10.54	39.14	39.1	13.7	300 PVC	0.3048	0.013	3.00	174.7	2.39	0.10	22.4%			
																												0.000
107	106	A-04A	0.077	0.005		0.082	0.86	0.19																				
			0.000																									
A-04B	0.051	0.015	0.066	0.74	0.14	0.85	10.64	74.44	0.00	0.00	10.64	63.63	63.6	17.3	300 PVC	0.3048	0.013	3.00	174.7	2.39	0.12	36.4%						
																											0.000	0.000
106	105		0.000	0.000	0.000	0.000	0.00	0.00	0.00	10.76	74.01	0.00	0.00	10.76	63.26	63.3	13.0	300 PVC	0.3048	0.013	3.00	174.7	2.39	0.09	36.2%			
																												0.000
BLDG3	105	BLDG3	0.076	0.000		0.076	0.90	0.19																				
			0.000																									
P3-1	0.000	0.065	0.065	0.20	0.04	0.23	10.00	76.81	0.00	0.00	10.00	17.40	15.9	12.5	250 PVC	0.254	0.013	1.00	62.0	1.22	0.17	25.6%						
																											0.000	0.000
105	104	A-03a	0.028	0.004		0.033	0.81	0.07																				
			0.000																									
		A-03b	0.036	0.010	0.046	0.75	0.10	0.00	0.00	0.00	10.85	73.69	0.00	0.00	10.85	108.74	108.7	57.6	375 PVC	0.381	0.013	2.00	258.7	2.27	0.42	42.0%		
A-02b	0.053	0.015	0.068	0.74	0.14	1.48	10.85	73.69	0.00	0.00	10.85	108.74	108.7	57.6	375 PVC	0.381	0.013	2.00	258.7	2.27	0.42	42.0%						
																											0.000	0.000
PARK	104	PARK1	0.000	0.000	0.519	0.519	0.40	0.58	0.58	10.00	76.81																	
			0.000																									
104	103		0.000	0.000	0.000	0.000	0.00	0.00	0.00	11.27	72.24	0.00	0.00	11.27	148.27	148.3	29.9	525 CONC	0.5334	0.013	0.30	245.7	1.10	0.45	60.3%			
																												0.000
103	102	A-01a	0.065	0.014		0.079	0.78	0.17																				
			0.000																									
A-01b	0.057	0.057	0.114	0.55	0.17	2.40	11.73	70.76	0.00	0.00	11.73	169.61	169.6	22.4	600 CONC	0.6096	0.013	0.30	350.8	1.20	0.31	48.3%						
																											0.000	0.000

STORM SEWER DESIGN SHEET

LOCATION		DEMAND											CAPACITY															
From MH	To MH	AREA						FLOW					PROPOSED SEWER PIPE SIZING / DESIGN															
		Area ID	Hardscape	Landscaping	Parkland	Total Area	Weighted Runoff Coefficient	Indivi 2.78 AR	Accum 2.78 AR	Time of Concentration (min.)	Rain Intensity (mm/hr)			Peak Flow (L/s)	TOTAL UNRESTRICTED PEAK FLOW (QDesign) (L/s)	PIPE PROPERTIES					CAPACITY (L/s)	FULL FLOW VELOCITY (m/s)	TIME OF FLOW (min.)	QPEAK DESIGN / QFULL (%)				
			0.90	0.20	0.40	(ha)					2yr	5yr	100yr			LENGTH (m)	SIZE / MATERIAL (mm / type)	ID ACTUAL (m)	ROUGHNESS	DESIGN GRADE (%)								
BASELINE SEWER RUN (PHASE4)																												
BLDG 4	503	BLDG 4	0.242 0.000 0.000	0.000		0.242	0.90	0.61 0.00 0.00	0.61 0.00 0.00	10.00 10.00 10.00	76.81			46.56 0.00 0.00	46.6	17.3	300 PVC	0.3048	0.013	2.00	142.7	1.96	0.15	32.6%				
BASELINE SEWER RUN (PHASE5)																												
BLDG5	EX	BLDG5	0.336 0.000 0.000	0.000		0.336	0.90	0.84 0.00 0.00																				
			P5-1	0.130 0.000 0.000	0.050		0.181	0.70	0.35 0.00 0.00																			
				P5-2	0.036 0.000 0.000	0.065		0.101	0.45	0.13 0.00 0.00	1.32 0.00 0.00	10.00 10.00 10.00	76.81			101.48 0.00 0.00	101.5	17.6	300 PVC	0.3048	0.013	2.00	142.7	1.96	0.15	71.1%		
		BASELINE SEWER RUN (PHASE3)																										
		BLDG6	502	BLDG3	0.190 0.000 0.000	0.000		0.190	0.90	0.48 0.00 0.00																		
					P6-1	0.000 -17.000 0.000	0.105 17.000		0.105	0.20	0.06 0.00 0.00																	
P6-2	0.153 0.000 0.000					0.037		0.189	0.76	0.40 0.00 0.00	0.94 0.00 0.00	10.00 10.00 10.00	76.81			71.91 0.00 0.00	71.9	17.6	300 PVC	0.3048	0.013	1.00	100.9	1.38	0.21	71.3%		

<p>DEMAND EQUATION $Q = 2.78 \text{ AIR}$</p> <p>Where : Q = Peak flow in litres per second (L/s) A = Area in hectares (ha) R = Weighted runoff coefficient (increased by 25% for 100-year) I = Rainfall intensity in millimeters per hour (mm/hr) Rainfall Intensity (I) is based on City of Ottawa IDF data presented in the City of Ottawa Sewer Design Guidelines (Oct. 2012)</p>	<p>CAPACITY EQUATION $Q_{full} = (1/n) A R^{(2/3)} S_o^{(1/2)}$</p> <p>Where : Q full = Capacity (L/s) n = Manning coefficient of roughness (0.013) A = Flow area (m²) R = Wetted perimeter (m) S_o = Pipe Slope/gradient</p>
--	---

Appendix D
Stormwater Management

TABLE 5A: Post-Development Runoff Coefficient "C" - Phase 1

Area	0.4	Ha	5 Year Event		100 Year Event	
			"C"	C _{avg}	"C" + 25%	*C _{avg}
Total	Hard	0.117	0.90	0.85	1.00	0.95
0.287	Roof	0.151	0.90		1.00	
	Soft	0.019	0.20		0.25	

* Remainder assumed hard due to
 * Roof area based on building foot
 * Soft area based on parkland det

TABLE 5B: 2 YEAR EVENT QUANTITY STORAGE REQUIREMENT - Phase 1

0.287 =Area (ha)
 0.85 = C

Return Period	Time (min)	Intensity (mm/hr)	Flow Q (L/s)	Allowable Runoff (L/s)	Net Flow to be Stored (L/s)	Storage Req'd (m ³)
2 YEAR	15	61.77	42.03	10.0	32.03	28.83
	20	52.03	35.41	10.0	25.41	30.49
	25	45.17	30.74	10.0	20.74	31.11
	30	40.04	27.25	10.0	17.25	31.05
	35	36.06	24.54	10.0	14.54	30.53

TABLE 5C: 5 YEAR EVENT QUANTITY STORAGE REQUIREMENT - Phase 1

0.287 =Area (ha)
 0.85 = C

Return Period	Time (min)	Intensity (mm/hr)	Flow Q (L/s)	Allowable Runoff (L/s)	Net Flow to be Stored (L/s)	Storage Req'd (m ³)
5 YEAR	25	60.90	41.44	10.0	31.44	47.16
	30	53.93	36.70	10.0	26.70	48.06
	35	48.52	33.02	10.0	23.02	48.34
	40	44.18	30.07	10.0	20.07	48.16
	45	40.63	27.65	10.0	17.65	47.65

TABLE 5D: 100 YEAR EVENT QUANTITY STORAGE REQUIREMENT - Phase 1

0.287 =Area (ha)
 0.95 = C

Return Period	Time (min)	Intensity (mm/hr)	Flow Q (L/s)	Allowable Runoff (L/s)	Net Flow to be Stored (L/s)	Storage Req'd (m ³)
100 YEAR	55	59.62	45.17	10.0	35.17	116.06
	60	55.89	42.35	10.0	32.35	116.44
	65	52.65	39.88	10.0	29.88	116.55
	70	49.79	37.72	10.0	27.72	116.43
	75	47.26	35.80	10.0	25.80	116.10

TABLE 5E: 100+20 YEAR EVENT QUANTITY STORAGE REQUIREMENT - Phase 1

0.287 =Area (ha)
 0.95 = C

Return Period	Time (min)	Intensity (mm/hr)	Flow Q (L/s)	Allowable Runoff (L/s)	Net Flow to be Stored (L/s)	Storage Req'd (m ³)
100 YEAR +20%	70	59.75	45.26	10.0	35.26	148.11
	75	56.71	42.96	10.0	32.96	148.32
	80	53.99	40.90	10.0	30.90	148.33
	85	51.54	39.05	10.0	29.05	148.16
	90	49.33	37.37	10.0	27.37	147.82

Equations:

Flow Equation

$$Q = 2.78 \times C \times I \times A$$

Where:

C is the runoff coefficient

I is the rainfall intensity, City of Ottawa IDF

A is the total drainage area

Runoff Coefficient Equation

$$C_s = (A_{\text{hard}} \times 0.9 + A_{\text{soft}} \times 0.2) / A_{\text{Tot}}$$

$$C_{100} = (A_{\text{hard}} \times 1.0 + A_{\text{soft}} \times 0.25) / A_{\text{Tot}}$$

TABLE 5F: Structure information - Phase 1

Structures	Size Dia.(mm)	Area (m ²)	T/G	Inv IN	Inv OUT
STORAGE TANK	N/A	48.59	90.30	N/A	n/a

TABLE 5G: Storage Provided - Phase 1

Area A-2: Storage Table				
Elevation (m)	System Depth (m)	TANK Volume (m ³)	Underground Volume (m ³)*	
90.350	0.00	0.00	0.00	
90.450	0.10	4.86	4.86	
90.550	0.20	9.72	9.72	
90.650	0.30	14.58	14.58	
90.750	0.40	19.44	19.44	
90.850	0.50	24.29	24.29	
90.950	0.60	29.15	29.15	
91.050	0.70	34.01	34.01	
91.150	0.80	38.87	38.87	
91.250	0.90	43.73	43.73	
91.350	1.00	48.59	48.59	
91.450	1.10	53.45	53.45	
91.550	1.20	58.31	58.31	
91.650	1.30	63.17	63.17	
91.750	1.40	68.03	68.03	
91.850	1.50	72.88	72.88	
91.950	1.60	77.74	77.74	
92.050	1.70	82.60	82.60	
92.150	1.80	87.46	87.46	
92.250	1.90	92.32	92.32	
92.350	2.00	97.18	97.18	
92.450	2.10	102.04	102.04	
92.550	2.20	106.90	106.90	
92.650	2.30	111.76	111.76	
92.750	2.40	116.62	116.62	
92.850	2.50	121.47	121.47	
92.950	2.60	126.33	126.33	
93.050	2.70	131.19	131.19	
93.150	2.80	136.05	136.05	
93.250	2.90	140.91	140.91	
93.350	3.00	145.77	145.77	
93.450	3.10	150.63	150.63	
93.550	3.20	155.49	155.49	
93.650	3.30	160.35	160.35	Top of tank
93.750	3.40	160.46	160.46	
93.800	3.45	160.52	160.52	
93.900	3.55	160.63	160.63	
94.000	3.65	160.74	160.74	
94.100	3.75	160.86	160.86	
94.200	3.85	160.97	160.97	
94.300	3.95	161.08	161.08	Proposed Lid elevation

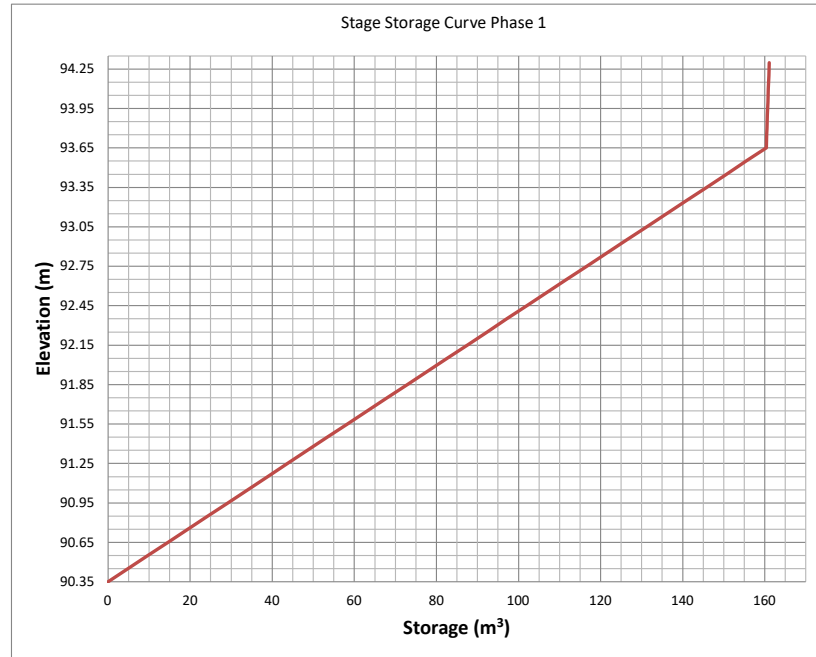

TABLE 5H: Orifice Sizing information- Phase 1

Design Event	PUMP			Outlet dia. (mm)	Required Volume (m ³)
	Flow (L/S)	Depth (m)	Elev (m)		
1:2 Year	10.0	0.64	90.99	250.00	31.11
1:5 Year	10.0	0.99	91.34	250.00	48.34
1:100 Year	10.0	2.40	92.75	250.00	116.55
1:100+20% Year	10.0	3.05	93.40	200.00	148.33

1500 Merivale

Post-Development Model Parameters

Area ID	Catchment Area (ha)	Runoff Coefficient (C)	Percent Impervious (%)	No Depression (%)	Flow Path Length (m)	Equivalent Width (m)	Average Slope (%)
Roadways							
A-01a	0.079	0.78	83%	0%	12.94	61.04	2.5%
A-01b	0.114	0.55	50%	0%	17.55	64.98	2.5%
A-02a	0.043	0.72	74%	0%	8.85	48.57	2.5%
A-02b	0.068	0.74	77%	0%	14.29	47.57	2.5%
A-03a	0.033	0.81	87%	0%	9.11	36.23	2.5%
A-03b	0.046	0.75	79%	0%	13.97	32.93	2.5%
A-04a	0.082	0.86	94%	0%	20.22	40.55	2.5%
A-04b	0.066	0.74	77%	0%	18.48	35.72	2.5%
A-05a	0.078	0.90	100%	0%	18.25	42.73	2.5%
A-05b	0.068	0.75	79%	0%	14.29	47.59	2.5%
A-06a	0.042	0.90	100%	0%	14.32	29.34	2.5%
A-06b	0.039	0.74	77%	0%	14.31	27.25	2.5%
B-01a	0.099	0.82	89%	0%	14.85	66.69	2.5%
B-01b	0.050	0.80	86%	0%	9.74	51.36	2.5%
B-02a	0.029	0.84	91%	0%	10.47	27.70	2.5%
B-02b	0.018	0.90	100%	0%	8.66	20.79	2.5%
B-03a	0.138	0.85	93%	0%	16.43	84.00	2.5%
B-03b	0.054	0.66	66%	0%	5.20	103.88	2.5%
B-04a	0.007	0.90	100%	0%	2.92	23.94	2.5%
B-04b	0.011	0.65	64%	0%	5.04	21.81	2.5%
B-05	0.130	0.86	94%	0%	22.26	58.40	2.5%
Building Phases							
BLDG1	0.151	0.90	100%	0%	30.53	49.46	0.5%
P1-1	0.106	0.51	44%	0%	26.55	51.22	0.5%
P1-2	0.031	0.61	59%	0%	26.55	51.22	0.5%
BLDG2	0.243	0.90	100%	0%	-	-	0.5%
P2-1	0.163	0.20	0%	0%	-	-	0.5%
PH02	0.406	0.62	60%	0%	34.14	118.94	0.5%
BLDG3	0.076	0.90	100%	0%	-	-	0.5%
P3-01	0.065	0.20	0%	0%	-	-	0.5%
PH03	0.141	0.58	54%	0%	41.07	34.33	0.5%
BLDG4	0.242	0.90	100%	0%	-	-	0.5%
PH04	0.242	0.90	100%	0%	86.46	27.99	0.5%
BLDG5	0.336	0.90	100%	0%	-	-	0.5%
P5-1	0.181	0.70	71%	0%	-	-	0.5%
P5-2	0.101	0.45	36%	0%	-	-	0.5%

1500 Merivale

Post-Development Model Parameters

Area ID	Catchment Area (ha)	Runoff Coefficient (C)	Percent Impervious (%)	No Depression (%)	Flow Path Length (m)	Equivalent Width (m)	Average Slope (%)
Roadways							
A-01a	0.079	0.78	83%	0%	12.94	61.04	2.5%
PH05	0.618	0.77	81%	0%	73.28	84.28	0.5%
BLDG6	0.190	0.90	100%	0%	-	-	0.5%
P6-1	0.093	0.20	0%	0%	-	-	0.5%
P6-2	0.189	0.76	80%	0%	-	-	0.5%
PH06	0.472	0.71	72%	0%	54.86	86.04	0.5%
BLDG7	0.192	0.90	100%	0%	-	-	0.5%
P7-1	0.115	0.32	17%	0%	-	-	0.5%
PH07	0.307	0.68	69%	0%	42.17	72.80	0.5%
BLDG8	0.191	0.90	100%	0%	-	-	0.5%
P8-1	0.134	0.34	20%	0%	-	-	0.5%
PH08	0.325	0.67	67%	0%	32.95	98.62	0.5%
BLDG9	0.202	0.90	100%	0%	-	-	0.5%
P9-1	0.273	0.81	87%	0%	-	-	0.5%
P9-2	0.126	0.33	19%	0%	-	-	0.5%
PH09	0.601	0.74	77%	0%	95.06	63.26	0.5%
BLDG10	0.326	0.90	100%	0%	-	-	0.5%
P10-1	0.154	0.45	36%	0%	-	-	0.5%
P10-2	0.061	0.40	29%	0%	-	-	0.5%
P10-3	0.088	0.39	27%	0%	-	-	0.5%
PH10	0.629	0.67	67%	0%	94.74	66.36	0.5%
BLDG11	0.111	0.90	100%	0%	-	-	0.5%
P11-1	0.040	0.90	100%	0%	-	-	0.5%
P11-2	0.049	0.20	0%	0%	-	-	0.5%
PH11	0.200	0.73	76%	0%	34.23	58.44	0.5%
Park & Direct Runoff							
PARK1	0.519	0.40	29%	0%	55.30	94.22	1.7%
D-02	0.004	0.90	100%	0%	2.82	14.18	0.5%
D-04	0.011	0.20	0%	0%	3.41	32.23	0.5%

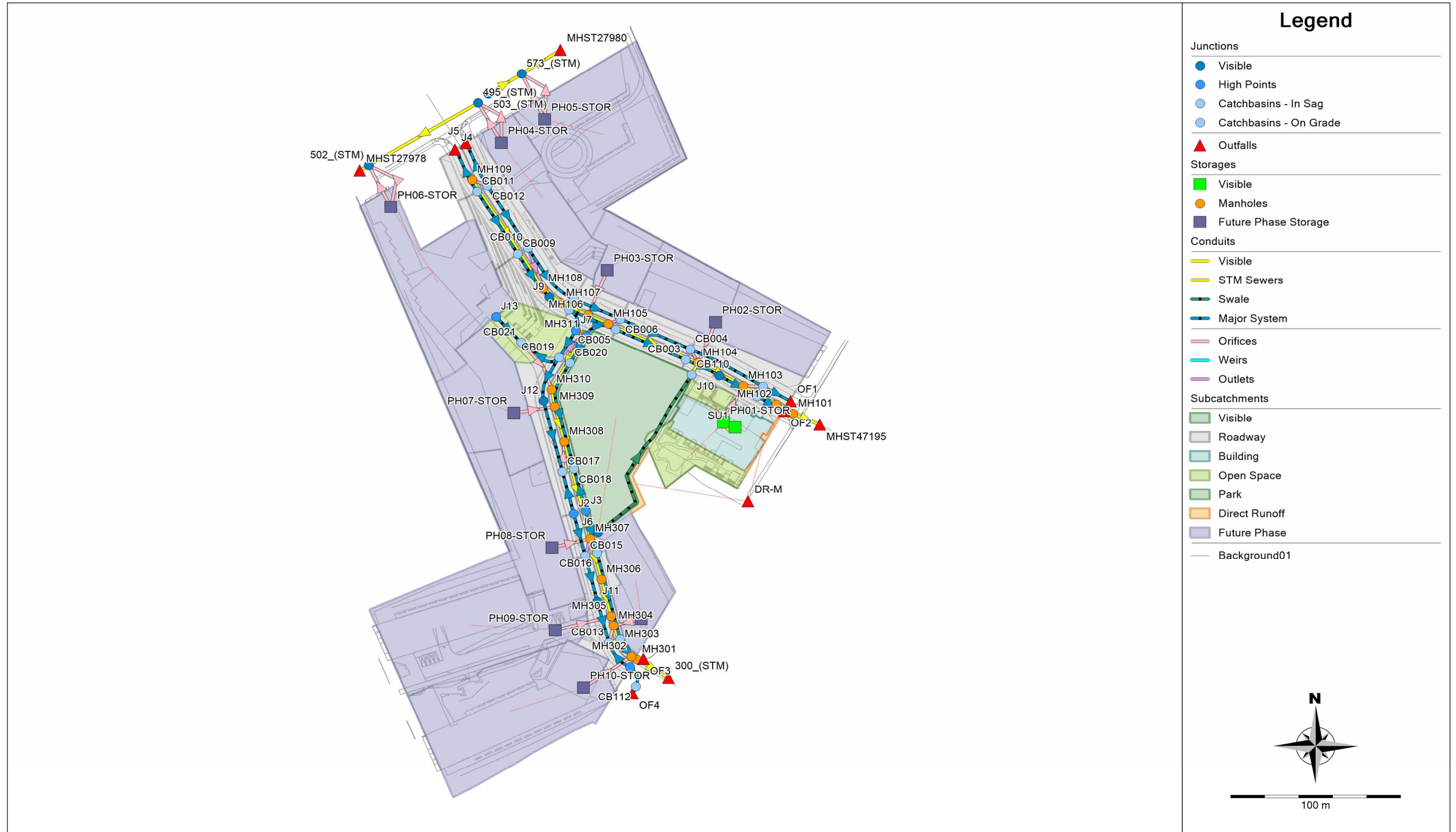

1500 Merivale

Peak Flows

Storm Distribution->		3hr Chicago					12hr SCS		
Return Period->		25mm	2yr	5yr	100yr	100yr +20%	2yr	5yr	100yr
To Merivale Road/ Parkwood Hills Minor System	North Outlet (Minor System)	96	130	202	272	314	77	134	217
	South Outlet (Minor System)	96	131	165	117	130	81	110	110
	Total to Merivale (Minor System)	192	261	367	389	444	158	244	327
To Merivale Road/ Parkwood Hills Major System	Direct Runoff	1	1	2	6	8	1	1	3
	North Outlet (Major System)	0	0	0	146	223	0	0	43
	South Outlet (Major System)	0	0	0	103	120	0	0	60
	Total to Merivale (Major System)	1	1	2	255	351	1	1	106
To Baseline/ Pinecrest Creek	Phase 4	1	3	5	8	9	4	5	8
	Phase 5	4	5	10	18	21	7	11	19
	Phase 6	3	4	4	15	17	4	6	17

1500 Merivale
HGL Elevations

Manhole ID	MH Invert Elevation (m)	T/G Elevation (m)	HGL Elevation - 100yr4hr (m)	HGL Elevation - 100yr4hr+20% (m)	Clearance from T/G (100yr) (m)	Clearance from T/G (100yr+20%) (m)
MH101	92.23	94.06	94.09	94.11	-0.03	-0.05
MH102	92.27	94.08	94.10	94.12	-0.02	-0.04
MH103	92.42	94.06	94.14	94.18	-0.08	-0.12
MH104	92.58	94.68	94.26	94.35	0.42	0.33
MH105	93.88	96.56	94.55	94.69	2.01	1.87
MH106	94.35	97.17	94.65	94.81	2.52	2.36
MH107	94.88	97.97	95.04	95.07	2.93	2.90
MH108	95.89	98.59	96.01	96.02	2.58	2.58
MH109	98.63	101.56	98.70	98.71	2.86	2.85
MH301	92.62	94.56	94.75	94.75	-0.19	-0.19
MH302	92.70	94.55	94.75	94.75	-0.20	-0.20
MH303	92.75	94.49	94.75	94.75	-0.26	-0.26
MH304	92.80	94.52	94.75	94.76	-0.23	-0.23
MH305	92.89	94.58	94.76	94.76	-0.17	-0.18
MH306	93.01	95.06	94.77	94.78	0.29	0.28
MH307	93.07	95.70	94.79	94.79	0.91	0.91
MH308	93.33	95.87	94.85	94.86	1.02	1.01
MH309	93.74	96.27	94.87	94.89	1.40	1.38
MH310	94.02	96.50	94.89	94.91	1.61	1.59
MH311	94.89	97.19	94.93	94.94	2.26	2.25

1500 Merivale
ROW Ponding Depths

Structure	T/G (m)	Max. Static Ponding (Spill Depth)		2-yr Event (3hr)				5-yr Event (3hr)				100-yr Event (3hr)				100-yr Event (+20%) (3hr)			
		Elev. (m)	Depth (m)	Elev. (m)	Depth (m)	Cascading Flow?	Cascade Depth (m)	Elev. (m)	Depth (m)	Cascading Flow?	Cascade Depth (m)	Elev. (m)	Depth (m)	Cascading Flow?	Cascade Depth (m)	Elev. (m)	Depth (m)	Cascading Flow?	Cascade Depth (m)
CB01	93.97	94.07	0.10	92.89	0.00	N	0.00	93.96	0.00	N	0.00	94.15	0.18	Y	0.08	94.16	0.19	Y	0.09
CB02	93.97	94.07	0.10	92.94	0.00	N	0.00	93.87	0.00	N	0.00	94.15	0.18	Y	0.08	94.16	0.19	Y	0.09
CB13	94.44	94.55	0.11	93.51	0.00	N	0.00	94.30	0.00	N	0.00	94.64	0.20	Y	0.09	94.65	0.21	Y	0.10
CB14	94.44	94.55	0.11	93.76	0.00	N	0.00	94.49	0.05	N	0.00	94.64	0.20	Y	0.09	94.65	0.21	Y	0.10
CB17	95.70	95.84	0.14	95.43	0.00	N	0.00	95.75	0.05	N	0.00	95.84	0.14	N	0.00	95.86	0.16	Y	0.02
CB18	95.70	95.84	0.14	94.24	0.00	N	0.00	94.79	0.00	N	0.00	95.84	0.14	N	0.00	95.86	0.16	Y	0.02
CB21	96.60	96.80	0.20	96.46	0.00	N	0.00	96.63	0.03	N	0.00	96.76	0.16	N	0.00	96.82	0.22	Y	0.02



- LEGEND**
- PROPERTY LINE
 - PROPOSED CURB
 - DC — PROPOSED DEPRESSED CURB
 - FC — PROPOSED FLUSH CURB
 - PROPOSED RETAINING WALL CW GUARD RAIL
 - ▭ PROPOSED WALKWAY
 - ▨ TERRACING 3:1 SLOPE MAX (UNLESS OTHERWISE INDICATED)
 - SURFACE PONDING EXTENTS
 - PROPOSED CAP
 - PROPOSED SANITARY SERVICE
 - PROPOSED STORM SEWER
 - PROPOSED CATCHBASIN MANHOLE
 - PROPOSED CATCHBASIN
 - ▣ PROPOSED LANDSCAPE DRAIN
 - ▣ PROPOSED AREA DRAIN

- PROPOSED TRENCH DRAIN
- PROPOSED SIAMISE CONNECTION
- PROPOSED HYDRANT & VALVE
- PROPOSED VALVE AND VALVE BOX
- PROPOSED BUILDING ENTRANCE
- BOREHOLE LOCATION (REFER TO GEOTECH REPORT)
- EXISTING UTILITY POLE CW GUY WIRES
- EXISTING VALVE & VALVE CHAMBER
- EXISTING HYDRANT CW VALVE
- EXISTING SANITARY MANHOLE
- EXISTING STORM MANHOLE
- EXISTING CATCHBASIN
- EXISTING STREETLIGHT
- EXISTING PARKING LOT SIGNAGE

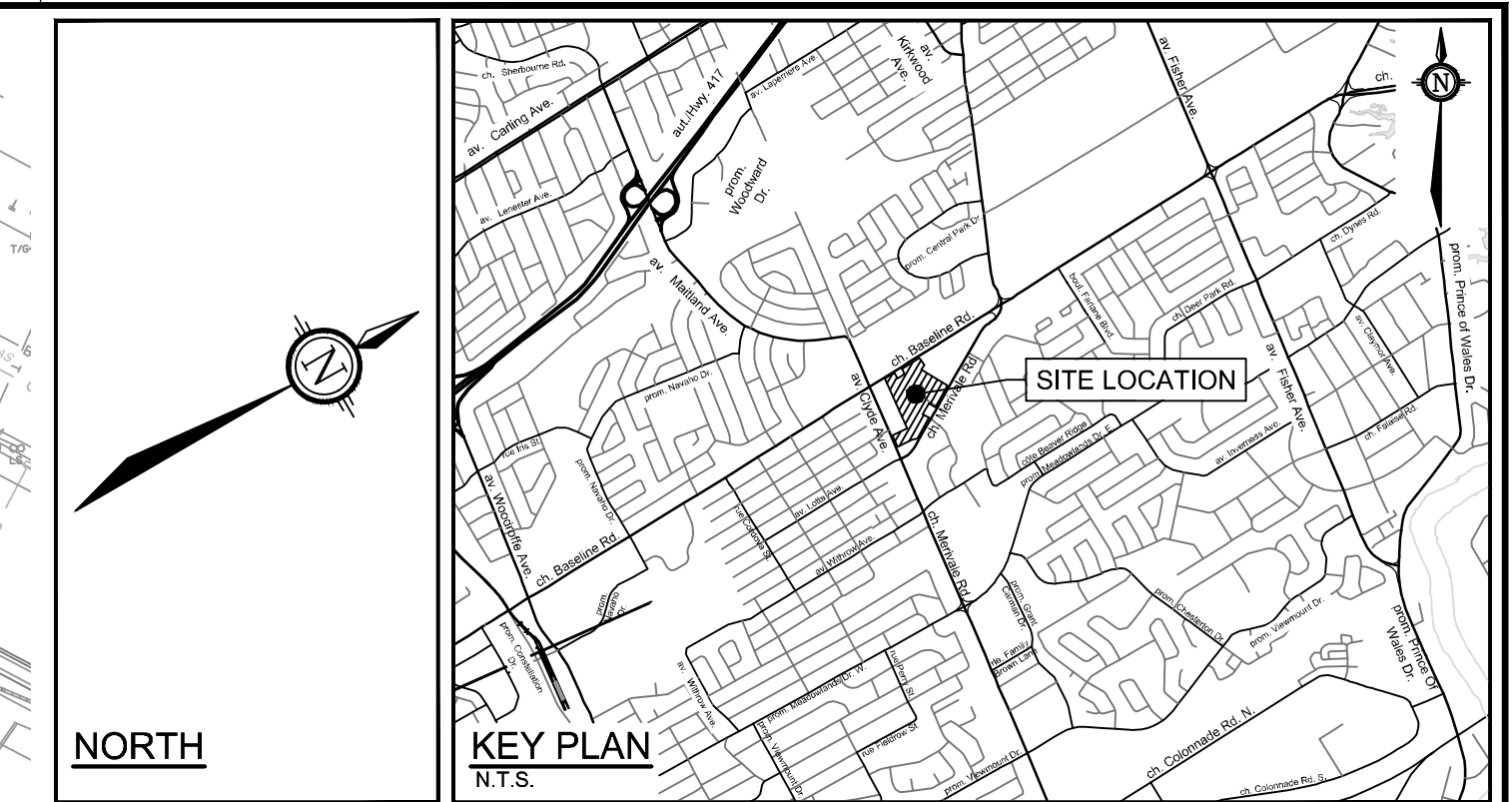

NOTE:
 THE POSITION OF ALL POLE LINES, CONDUITS, WATERMANS, SEWERS AND OTHER UNDERGROUND AND OVERGROUND UTILITIES AND STRUCTURES IS NOT NECESSARILY SHOWN ON THE CONTRACT DRAWINGS, AND WHERE SHOWN, THE ACCURACY OF THE POSITION OF SUCH UTILITIES AND STRUCTURES IS NOT GUARANTEED. BEFORE STARTING WORK, DETERMINE THE EXACT LOCATION OF ALL SUCH UTILITIES AND STRUCTURES AND ASSUME ALL LIABILITY FOR DAMAGE TO THEM.

REFER TO 121009-NDGR FOR ADDITIONAL NOTES & DETAILS

No.	REVISION	DATE	BY
1.	UPDATED PER CITY COMMENTS	AUG 1/2024	ARM

SCALE	1:500
	0 5 10 15 20

DESIGN	ARM
CHECKED	GJM
DRAWN	CJF/ARM
CHECKED	ARM
APPROVED	GJM

NOVATECH Engineers, Planners & Landscape Architects Suite 200, 240 Michael Cowland Drive Ottawa, Ontario, Canada K2M 1P6 Telephone: (613) 254-9643 Facsimile: (613) 254-5867 Website: www.novatech-eng.com	LOCATION CITY or TOWNSHIP NAME OF DEVELOPMENT DRAWING NAME PONDING PLAN	PROJECT No. 121009 REV # 1 121009-PND
	FOR REVIEW ONLY	

1500 Merivale

Inlet Control Device Parameters



Engineers, Planners & Landscape Architects

Structure	Diameter (mm)	Max. Head (2yr) (m)	Calculated 2yr Capture Rate (L/s)	Model Results*			
				2yr Approach Flow (L/s)	2yr Capture Rate (L/s)	100yr Approach Flow (L/s)	100yr Capture Rate (L/s)
CB01	152	1.22	55.1	18.9	18.8	109.2	8.7
CB02	178	1.11	72.0	19.6	19.5	100.1	12.1
CB03	83	1.17	16.1	14.1	9.3	46.5	19.4
CB04	83	1.17	16.1	18.4	11.1	70.8	19.4
CB05	83	1.42	17.7	16.5	9.3	45.4	19.4
CB06	83	1.42	17.7	16.3	9.2	57.9	19.4
CB07	102	1.15	24.1	30.2	10.7	75.8	21.0
CB08	83	1.16	16.0	17.7	9.1	55.3	19.4
CB09	83	1.16	16.0	20.3	6.7	48.5	13.1
CB10	83	1.16	16.0	14.2	7.4	41.3	17.5
CB11	83	1.16	16.0	9.0	5.3	20.8	11.0
CB12	83	1.16	16.0	6.5	4.0	18.7	10.1
CB13	152	1.12	52.8	21.8	21.7	73.0	0.0**
CB14	83	1.16	16.0	10.5	10.3	66.3	0.0**
CB15	83	1.16	16.0	5.7	2.8	14.2	6.3
CB16	83	1.16	16.0	3.8	2.7	8.9	5.9
CB17	102	1.75	29.7	27.7	27.3	67.9	22.5
CB18	83	1.76	19.7	8.4	8.1	64.0	14.9
CB19	83	1.16	16.0	10.7	0.8	28.9	2.1
CB20	83	1.16	16.0	1.6	1.1	5.2	3.6
CB21	127	1.19	37.9	36.0	35.6	90.2	40.4

*From PCSWMM Model, 2-year & 100-year 3-hour Chicago storm distribution

**Downstream HGL boundary condition is higher than T/G for these CBs, so no inflow occurs

1500 Merivale ICD Rating Curves

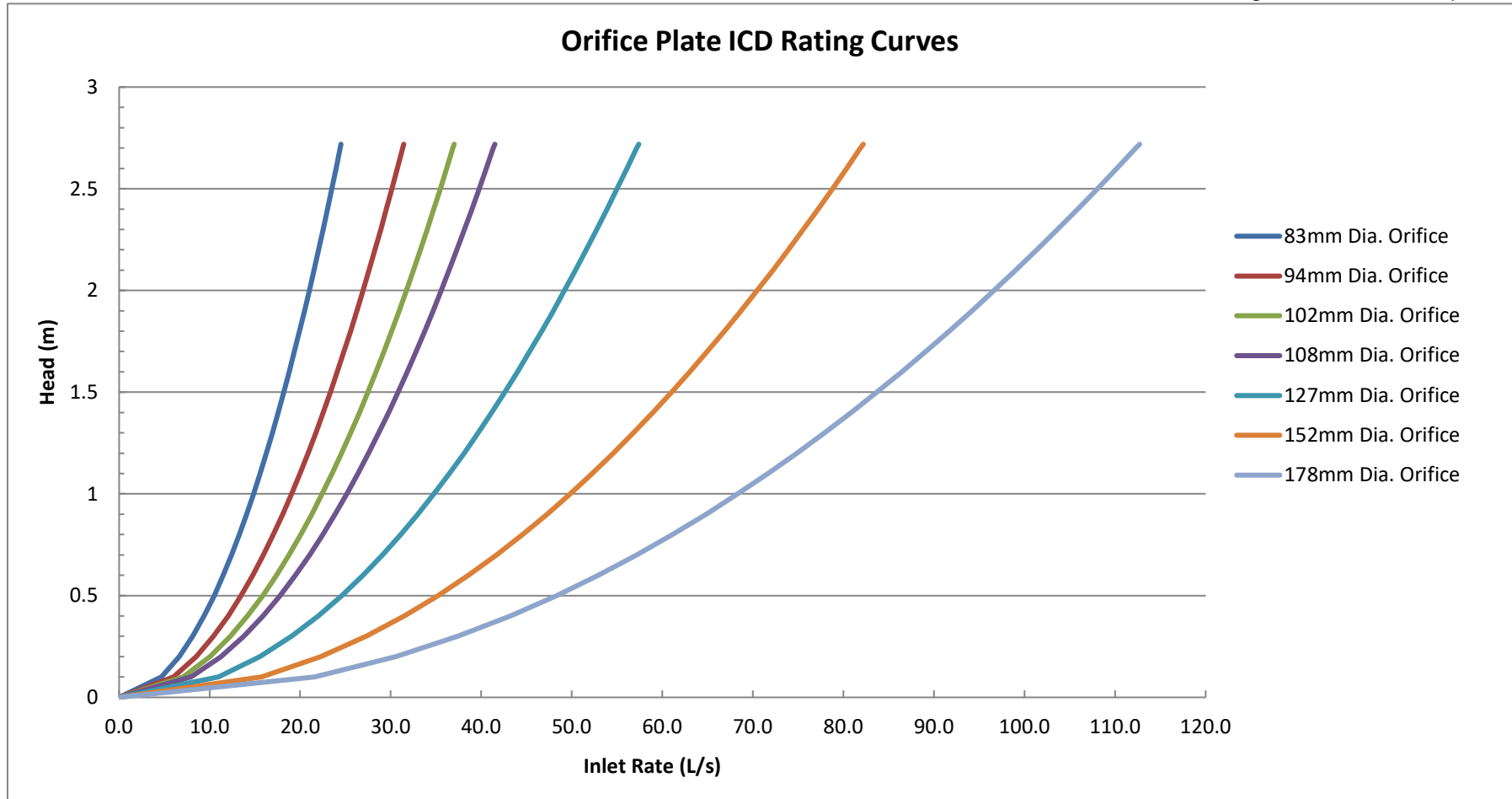

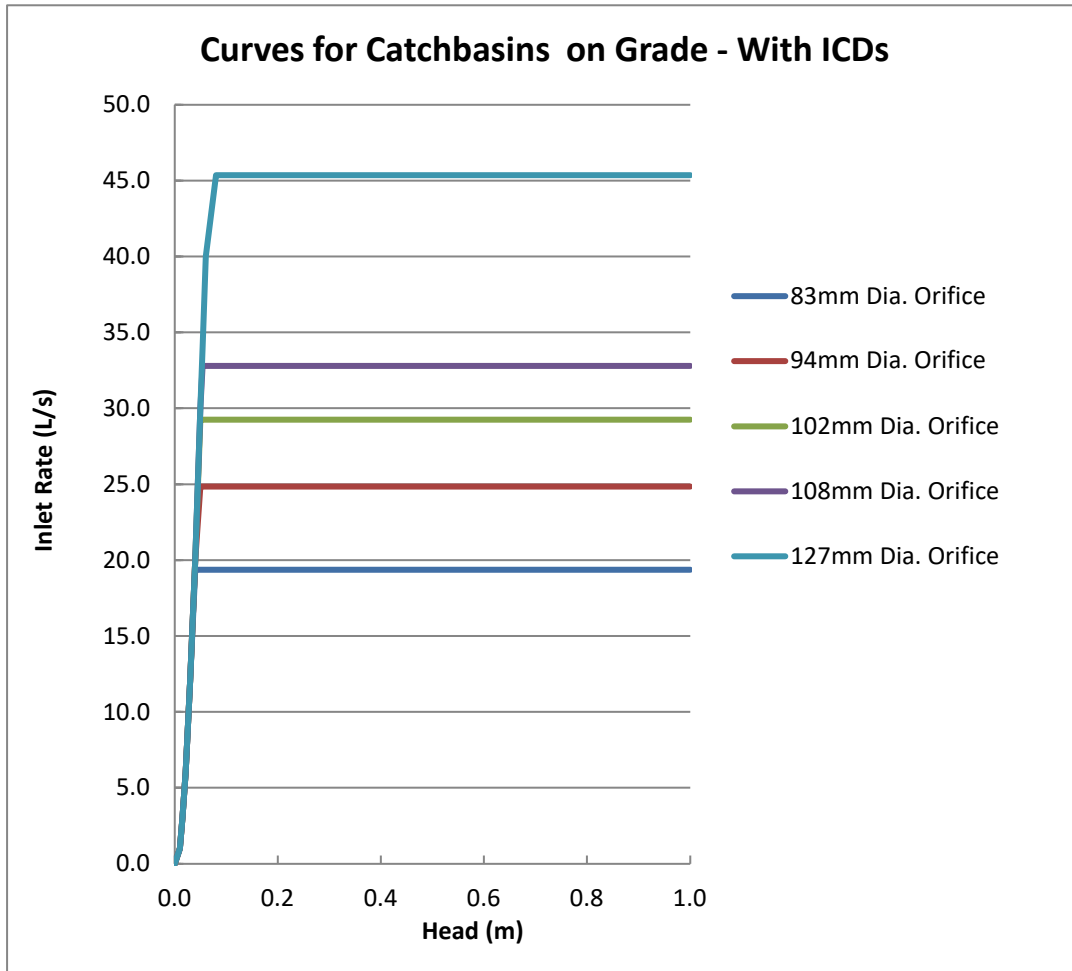

Curb Inlet Catchbasins on Continuous Grade

Depth vs. Captured Flow Curve

A standard depth vs. captured flow curve for catch basins on a continuous grade was provided to Novatech by City staff for use in a dual-drainage model of an existing residential neighbourhood. This standard curve was derived using the inlet curves in Appendix 7A of the Ottawa Sewer Design Guidelines.

Novatech reviewed the methodology used to create this standard curve (described below) and determined that it was suitable for general use in other dual-drainage models.

- MTO Design Chart 4.04 provides the relationship between the gutter flow rate (Q_g) and flow spread (T) for Barrier Curb.
- MTO Design Chart 4.12 provides the relationship between flow spread (T) and flow depth (D).
- The relationship between the gutter flow rate (Q_g) and flow depth (D) was determined for different road slopes using the above charts and Manning's equation (refer to pages 58-60 of the MTO Drainage Management Manual – Part 2);
- The relationship between approach flow (Q_a) and captured flow (Q_c) was determined for different road slopes using the design chart for Barrier Curb with Gutter (Appendix 7-A.2).
- Using the above information, a family of curves was developed to characterize the relationship between flow depth and captured flow for curb inlet catchbasins on different road slopes. The results of this exercise can be summarized as follows:
 - For a given flow depth, the gutter flow rate (Q_g) increases as the road slope increases.
 - The capture efficiency (Q_c) of curb inlet catchbasins decrease as the road slope increases.
 - The net result is that the relationship between flow depth and capture rate is largely independent of road slope: While approach flow vs. captured flow (Q_a vs. Q_c) varies significantly with road grade, flow depth vs. captured flow (D vs. Q_c) does not.

Since there was very little difference in the flow depth vs. captured flow curves for different road slopes, this family of curves was averaged to create a single standard curve for use in dual-drainage models.

Inlet Control Devices

The standard depth vs. capture flow curve was modified to account for the installation of ICDs in curb inlet catchbasins on continuous grade. Separate inlet curves were created for each standard ICD orifice size by capping the inlet rate on the depth vs. capture flow curve at the maximum flow rate through the ICD at a head of 1.2m (depth from centerline of CB lead to top of CICB frame).

1500 Merivale
Design Storm Time Series Data
3-hour Chicago Design Storms



C25mm-3.stm		C2-3.stm		C5-3.stm	
Duration	Intensity	Duration	Intensity	Duration	Intensity
min	mm/hr	min	mm/hr	min	mm/hr
0:00	0	0:00	0	0:00	0
0:10	2.21	0:10	2.81	0:10	3.68
0:20	2.75	0:20	3.5	0:20	4.58
0:30	3.68	0:30	4.69	0:30	6.15
0:40	5.73	0:40	7.3	0:40	9.61
0:50	14.29	0:50	18.21	0:50	24.17
1:00	60.28	1:00	76.81	1:00	104.19
1:10	18.9	1:10	24.08	1:10	32.04
1:20	9.7	1:20	12.36	1:20	16.34
1:30	6.53	1:30	8.32	1:30	10.96
1:40	4.94	1:40	6.3	1:40	8.29
1:50	3.99	1:50	5.09	1:50	6.69
2:00	3.37	2:00	4.29	2:00	5.63
2:10	2.92	2:10	3.72	2:10	4.87
2:20	2.58	2:20	3.29	2:20	4.3
2:30	2.32	2:30	2.95	2:30	3.86
2:40	2.1	2:40	2.68	2:40	3.51
2:50	1.93	2:50	2.46	2:50	3.22
3:00	1.79	3:00	2.28	3:00	2.98

1500 Merivale
Design Storm Time Series Data
3-hour Chicago Design Storms



C100-3.stm		C100-3+20%.stm	
Duration	Intensity	Duration	Intensity
min	mm/hr	min	mm/hr
0:00	0	0:00	0
0:10	6.05	0:10	6.14
0:20	7.54	0:20	9.05
0:30	10.16	0:30	12.19
0:40	15.97	0:40	19.16
0:50	40.65	0:50	48.78
1:00	178.56	1:00	214.27
1:10	54.05	1:10	64.86
1:20	27.32	1:20	32.78
1:30	18.24	1:30	21.89
1:40	13.74	1:40	16.49
1:50	11.06	1:50	13.27
2:00	9.29	2:00	11.15
2:10	8.02	2:10	9.62
2:20	7.08	2:20	8.5
2:30	6.35	2:30	7.62
2:40	5.76	2:40	6.91
2:50	5.28	2:50	6.34
3:00	4.88	3:00	5.86

1500 Merivale
Design Storm Time Series Data
4-hour Chicago Design Storms

C25mm-4.stm

Duration	Intensity
min	mm/hr
0:00	0
0:10	1.51
0:20	1.75
0:30	2.07
0:40	2.58
0:50	3.46
1:00	5.39
1:10	13.44
1:20	56.67
1:30	17.77
1:40	9.12
1:50	6.14
2:00	4.65
2:10	3.76
2:20	3.17
2:30	2.74
2:40	2.43
2:50	2.18
3:00	1.98
3:10	1.81
3:20	1.68
3:30	1.56
3:40	1.47
3:50	1.38
4:00	1.31

1500 Merivale
Design Storm Time Series Data
SCS Design Storms



S2-12.stm		S5-12.stm		S100-12.stm	
Duration	Intensity	Duration	Intensity	Duration	Intensity
min	mm/hr	min	mm/hr	min	mm/hr
0:00	0.00	0:00	0	0:00	0
0:30	1.27	0:30	1.69	0:30	2.82
1:00	0.59	1:00	0.79	1:00	1.31
1:30	1.10	1:30	1.46	1:30	2.44
2:00	1.10	2:00	1.46	2:00	2.44
2:30	1.44	2:30	1.91	2:30	3.19
3:00	1.27	3:00	1.69	3:00	2.82
3:30	1.69	3:30	2.25	3:30	3.76
4:00	1.69	4:00	2.25	4:00	3.76
4:30	2.29	4:30	3.03	4:30	5.07
5:00	2.88	5:00	3.82	5:00	6.39
5:30	4.57	5:30	6.07	5:30	10.14
6:00	36.24	6:00	48.08	6:00	80.38
6:30	9.23	6:30	12.25	6:30	20.47
7:00	4.06	7:00	5.39	7:00	9.01
7:30	2.71	7:30	3.59	7:30	6.01
8:00	2.37	8:00	3.15	8:00	5.26
8:30	1.86	8:30	2.47	8:30	4.13
9:00	1.95	9:00	2.58	9:00	4.32
9:30	1.27	9:30	1.69	9:30	2.82
10:00	1.02	10:00	1.35	10:00	2.25
10:30	1.44	10:30	1.91	10:30	3.19
11:00	0.93	11:00	1.24	11:00	2.07
11:30	0.85	11:30	1.12	11:30	1.88
12:00	0.85	12:00	1.12	12:00	1.88

1500 Merivale

Roadway Cross-Sections

7.0m Roadway (Left) - No Parking

0	0.35
5	0.16
5.99	0.15
6	0
9.5	0.1

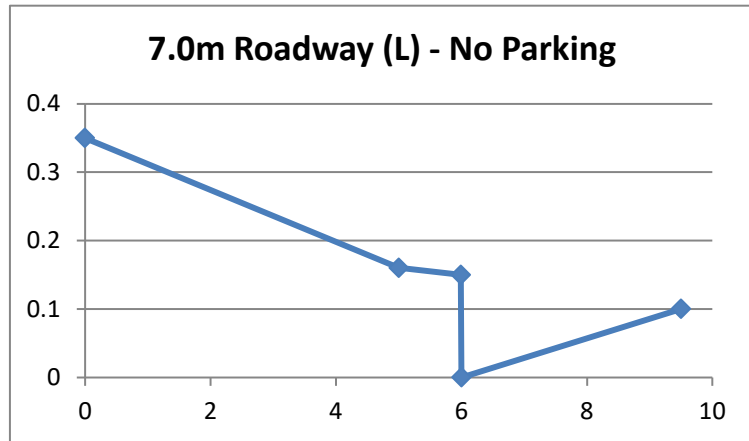

7.0m Roadway (Right) - No Parking

0	0.1
3.5	0
3.51	0.15
4.5	0.16
9.5	0.35

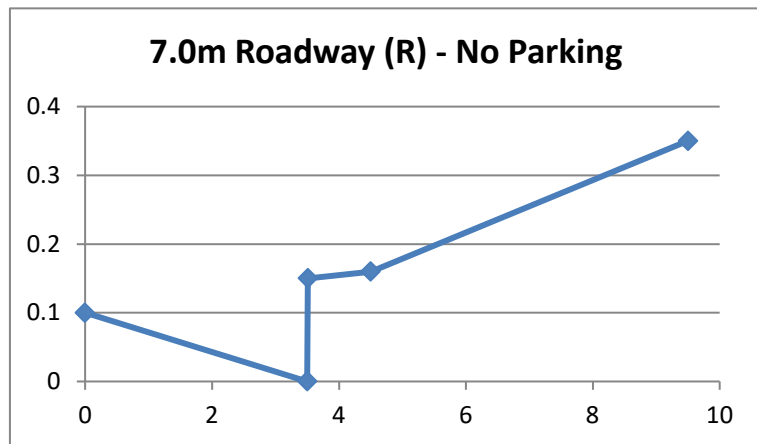

7.0m Roadway (Left) - No Parking

0	0.35
5	0.21
5.99	0.2
6	0.05
8.5	0
12	0.1

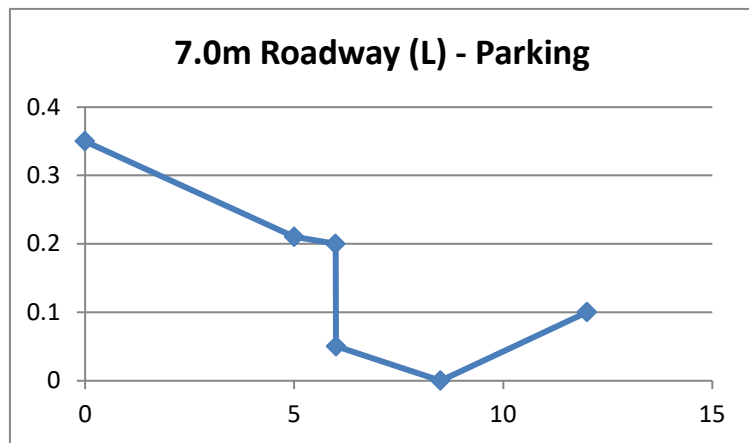

1500 Merivale

Roadway Cross-Sections

7.0m Roadway (Right) - No Parking

0	0.1
3.5	0
6	0.05
6.01	0.2
7	0.21
12	0.35

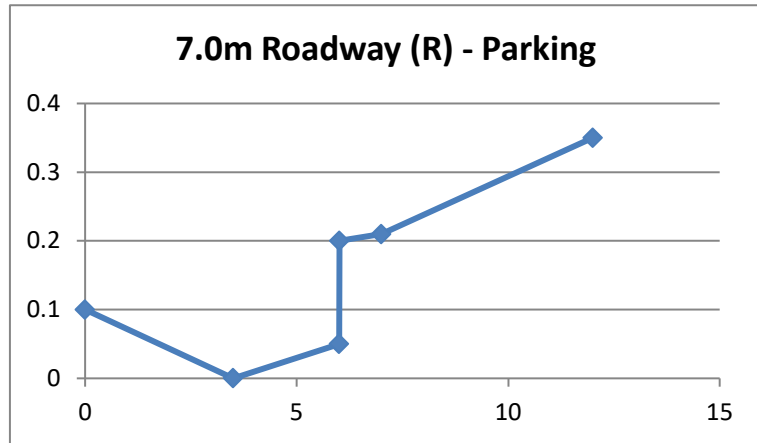

EPA STORM WATER MANAGEMENT MODEL - VERSION 5.2 (Build 5.2.4)

1500 Merivale - Detailed design of Phase 1

WARNING 04: minimum elevation drop used for Conduit 302-301
 WARNING 03: negative offset ignored for Link C15
 WARNING 03: negative offset ignored for Link C16
 WARNING 04: minimum elevation drop used for Conduit C16
 WARNING 04: minimum elevation drop used for Conduit C20
 WARNING 04: minimum elevation drop used for Conduit C26
 WARNING 04: minimum elevation drop used for Conduit C32
 WARNING 02: maximum depth increased for Node CB001
 WARNING 02: maximum depth increased for Node CB002
 WARNING 02: maximum depth increased for Node CB013
 WARNING 02: maximum depth increased for Node CB014
 WARNING 02: maximum depth increased for Node CB017
 WARNING 02: maximum depth increased for Node CB018
 WARNING 02: maximum depth increased for Node CB112
 WARNING 02: maximum depth increased for Node J13
 WARNING 02: maximum depth increased for Node PH01-STOR

 Element Count

Number of rain gages 1
 Number of subcatchments ... 37
 Number of nodes 81
 Number of links 102
 Number of pollutants 0
 Number of land uses 0

 Raingage Summary

Name	Data Source	Data Type	Recording Interval
Raingage1	03-C100yr-3hr	INTENSITY	10 min.

 Subcatchment Summary

Name Outlet	Area	Width	%Imperv	%Slope	Rain Gage
A01a	0.08	61.04	83.00	2.5000	Raingage1
CB001					
A01b	0.11	64.98	50.00	2.5000	Raingage1
CB002					
A02a	0.04	48.57	74.00	2.5000	Raingage1
CB003					
A02b	0.07	47.57	77.00	2.5000	Raingage1
CB004					
A03a	0.03	36.23	87.00	2.5000	Raingage1

A03b	0.05	32.93	79.00	2.5000	Raingage1
CB006					
A04a	0.08	40.55	94.00	2.5000	Raingage1
CB007					
A04b	0.07	35.72	77.00	2.5000	Raingage1
CB008					
A05a	0.08	42.73	100.00	2.5000	Raingage1
CB009					
A05b	0.07	47.59	79.00	2.5000	Raingage1
CB010					
A06a	0.04	29.34	100.00	2.5000	Raingage1
CB011					
A06b	0.04	27.25	77.00	2.5000	Raingage1
CB012					
B01a	0.10	66.69	89.00	2.5000	Raingage1
CB013					
B01b	0.05	51.36	86.00	2.5000	Raingage1
CB014					
B02a	0.03	27.70	91.00	2.5000	Raingage1
CB015					
B02b	0.02	20.79	100.00	2.5000	Raingage1
CB016					
B03a	0.14	84.00	93.00	2.5000	Raingage1
CB017					
B03b	0.05	103.88	66.00	2.5000	Raingage1
CB018					
B04a	0.01	23.94	100.00	2.5000	Raingage1
CB019					
B04b	0.01	21.81	64.00	2.5000	Raingage1
CB020					
B-05	0.13	58.40	94.00	2.5000	Raingage1
CB021					
BLDG01	0.15	49.46	100.00	0.5000	Raingage1
PH01-STOR					
P01-1	0.11	39.92	44.00	0.5000	Raingage1
PH01-STOR					
P01-2	0.03	30.33	59.00	0.5000	Raingage1
PH01-STOR					
PH02	0.41	118.94	60.00	0.5000	Raingage1
PH02-STOR					
PH03	0.14	34.33	10.00	0.5000	Raingage1
PH03-STOR					
PH04	0.24	27.99	100.00	0.5000	Raingage1
PH04-STOR					
PH05	0.62	84.28	81.00	0.5000	Raingage1
PH05-STOR					
PH06	0.47	86.04	72.00	0.5000	Raingage1
PH06-STOR					
PH07	0.31	72.80	69.00	0.5000	Raingage1
PH07-STOR					
PH08	0.33	98.62	67.00	0.5000	Raingage1
PH08-STOR					
PH09	0.60	63.26	77.00	0.5000	Raingage1
PH09-STOR					
PH10	0.63	66.36	67.00	0.5000	Raingage1
PH10-STOR					
PH11	0.20	58.44	76.00	0.5000	Raingage1
PH11-STOR					
xD-02	0.00	14.18	100.00	0.5000	Raingage1
DR-M					

```

xD-04      0.01  32.23   0.00  0.5000 Raingagel
DR-M
xPARK01    0.52  94.22   29.00  1.7000 Raingagel
J6
    
```

Node Summary

Name	Type	Invert Elev.	Max. Depth	Ponded Area	External Inflow
495_(STM)	JUNCTION	99.36	1.79	0.0	
502_(STM)	JUNCTION	97.72	1.83	0.0	
503_(STM)	JUNCTION	98.99	2.33	0.0	
573_(STM)	JUNCTION	98.75	1.74	0.0	
CB001	JUNCTION	92.67	1.76	0.0	
CB002	JUNCTION	92.77	1.66	0.0	
CB003	JUNCTION	94.88	0.35	0.0	
CB004	JUNCTION	94.88	0.35	0.0	
CB005	JUNCTION	96.30	0.35	0.0	
CB006	JUNCTION	96.30	0.35	0.0	
CB007	JUNCTION	97.67	0.35	0.0	
CB008	JUNCTION	97.67	0.35	0.0	
CB009	JUNCTION	99.76	0.35	0.0	
CB010	JUNCTION	99.76	0.35	0.0	
CB011	JUNCTION	101.37	0.35	0.0	
CB012	JUNCTION	101.37	0.35	0.0	
CB013	JUNCTION	93.24	1.65	0.0	
CB014	JUNCTION	93.24	1.65	0.0	
CB015	JUNCTION	95.42	0.35	0.0	
CB016	JUNCTION	95.42	0.35	0.0	
CB017	JUNCTION	93.90	2.25	0.0	
CB018	JUNCTION	93.90	2.25	0.0	
CB019	JUNCTION	96.80	0.35	0.0	
CB020	JUNCTION	96.80	0.35	0.0	
CB021	JUNCTION	95.35	1.60	0.0	
CB110	JUNCTION	92.89	2.01	0.0	
CB112	JUNCTION	93.32	1.55	0.0	
J1	JUNCTION	94.55	0.35	0.0	
J10	JUNCTION	94.46	0.35	0.0	
J11	JUNCTION	94.91	0.35	0.0	
J12	JUNCTION	96.37	0.35	0.0	
J13	JUNCTION	96.95	0.35	0.0	
J2	JUNCTION	95.84	0.35	0.0	
J3	JUNCTION	95.84	0.35	0.0	
J6	JUNCTION	95.79	0.30	0.0	
J7	JUNCTION	97.16	0.35	0.0	
J8	JUNCTION	97.16	0.35	0.0	
J9	JUNCTION	98.31	0.35	0.0	
300_(STM)	OUTFALL	92.12	1.20	0.0	
DR-M	OUTFALL	0.00	0.00	0.0	
J4	OUTFALL	101.95	0.35	0.0	
J5	OUTFALL	101.95	0.35	0.0	
MHST27978	OUTFALL	97.28	0.60	0.0	
MHST27980	OUTFALL	97.90	0.33	0.0	
MHST47195	OUTFALL	91.50	1.36	0.0	

OF1	OUTFALL	94.07	0.35	0.0
OF2	OUTFALL	94.07	0.35	0.0
OF3	OUTFALL	94.55	0.35	0.0
OF4	OUTFALL	94.55	0.35	0.0
MH101	STORAGE	92.23	1.83	0.0
MH102	STORAGE	92.27	1.81	0.0
MH103	STORAGE	92.42	1.64	0.0
MH104	STORAGE	92.58	2.10	0.0
MH105	STORAGE	93.88	2.68	0.0
MH106	STORAGE	94.35	2.82	0.0
MH107	STORAGE	94.88	3.09	0.0
MH108	STORAGE	95.89	2.70	0.0
MH109	STORAGE	98.63	2.93	0.0
MH301	STORAGE	92.62	1.94	0.0
MH302	STORAGE	92.70	1.85	0.0
MH303	STORAGE	92.75	1.74	0.0
MH304	STORAGE	92.80	1.72	0.0
MH305	STORAGE	92.89	1.69	0.0
MH306	STORAGE	93.01	2.05	0.0
MH307	STORAGE	93.07	2.63	0.0
MH308	STORAGE	93.33	2.54	0.0
MH309	STORAGE	93.74	2.53	0.0
MH310	STORAGE	94.02	2.48	0.0
MH311	STORAGE	94.89	2.30	0.0
PH01-STOR	STORAGE	93.00	3.00	0.0
PH02-STOR	STORAGE	93.00	2.00	0.0
PH03-STOR	STORAGE	94.40	2.00	0.0
PH04-STOR	STORAGE	99.50	2.00	0.0
PH05-STOR	STORAGE	99.00	2.00	0.0
PH06-STOR	STORAGE	97.80	2.00	0.0
PH07-STOR	STORAGE	94.30	2.00	0.0
PH08-STOR	STORAGE	93.70	2.00	0.0
PH09-STOR	STORAGE	93.50	2.00	0.0
PH10-STOR	STORAGE	93.50	2.00	0.0
PH11-STOR	STORAGE	93.50	2.00	0.0
SU1	STORAGE	93.00	2.00	0.0

Link Summary

Name	From Node	To Node	Type	Length	%

101-MV	MH101	MHST47195	CONDUIT	17.1	
0.2918	0.0130				
102-101	MH102	MH101	CONDUIT	11.3	
0.2661	0.0130				
103-102	MH103	MH102	CONDUIT	22.4	
0.3131	0.0130				
104-103	MH104	MH103	CONDUIT	29.9	
0.2676	0.0130				
105-104	MH105	MH104	CONDUIT	57.7	
1.9950	0.0130				
106-105	MH106	MH105	CONDUIT	13.1	
2.9892	0.0130				
107-106	MH107	MH106	CONDUIT	17.3	3.00

OCB013	CB013	MH304	ORIFICE				
OCB014	CB014	MH304	ORIFICE				
OCB017	CB017	MH308	ORIFICE				
OCB018	CB018	MH308	ORIFICE				
OCB021	CB021	MH310	ORIFICE				
OHP01	PH01-STOR	MH103	ORIFICE				
OPH02	PH02-STOR	MH104	ORIFICE				
OPH03	PH03-STOR	MH106	ORIFICE				
OPH04a	PH04-STOR	495_(STM)	ORIFICE				
OPH04b	PH04-STOR	495_(STM)	ORIFICE				
OPH05a	PH05-STOR	573_(STM)	ORIFICE				
OPH05b	PH05-STOR	573_(STM)	ORIFICE				
OPH06a	PH06-STOR	502_(STM)	ORIFICE				
OPH06b	PH06-STOR	502_(STM)	ORIFICE				
OPH07	PH07-STOR	MH309	ORIFICE				
OPH08	PH08-STOR	MH307	ORIFICE				
OPH09	PH09-STOR	MH305	ORIFICE				
OPH10	PH10-STOR	MH302	ORIFICE				
OPH11	PH11-STOR	MH304	ORIFICE				
W1	PH01-STOR	SU1	WEIR				
OCB003	CB003	MH104	OUTLET				
OCB004	CB004	MH104	OUTLET				
OCB005	CB005	MH105	OUTLET				
OCB006	CB006	MH105	OUTLET				
OCB007	CB007	MH107	OUTLET				
OCB008	CB008	MH107	OUTLET				
OCB009	CB009	MH108	OUTLET				
OCB010	CB010	MH108	OUTLET				
OCB011	CB011	MH109	OUTLET				
OCB012	CB012	MH109	OUTLET				
OCB015	CB015	MH307	OUTLET				
OCB016	CB016	MH307	OUTLET				
OCB019	CB019	MH311	OUTLET				
OCB020	CB020	MH311	OUTLET				

Cross Section Summary							

Full			Full	Full	Hyd.	Max.	No. of
Conduit	Shape	Depth	Area	Rad.	Width	Barrels	
Flow							

101-MV	CIRCULAR	0.68	0.36	0.17	0.68	1	
454.12							
102-101	CIRCULAR	0.68	0.36	0.17	0.68	1	
433.60							
103-102	CIRCULAR	0.60	0.28	0.15	0.60	1	
343.60							
104-103	CIRCULAR	0.53	0.22	0.13	0.53	1	
222.47							
105-104	CIRCULAR	0.38	0.11	0.09	0.38	1	
247.66							
106-105	CIRCULAR	0.30	0.07	0.07	0.30	1	
167.20							
107-106	CIRCULAR	0.30	0.07	0.07	0.30	1	

108-107	CIRCULAR	0.30	0.07	0.07	0.30	1	
167.01							
109-108	CIRCULAR	0.30	0.07	0.07	0.30	1	
167.36							
301-MV	CIRCULAR	0.75	0.44	0.19	0.75	1	
536.38							
302-301	CIRCULAR	0.68	0.36	0.17	0.68	1	
74.70							
303-302	CIRCULAR	0.68	0.36	0.17	0.68	1	
378.34							
304-303	CIRCULAR	0.68	0.36	0.17	0.68	1	
342.95							
305-304	CIRCULAR	0.60	0.28	0.15	0.60	1	
249.81							
306-305	CIRCULAR	0.53	0.22	0.13	0.53	1	
200.73							
307-306	CIRCULAR	0.53	0.22	0.13	0.53	1	
189.70							
308-307	CIRCULAR	0.45	0.16	0.11	0.45	1	
155.06							
309-308	CIRCULAR	0.38	0.11	0.09	0.38	1	
217.42							
310-309	CIRCULAR	0.30	0.07	0.07	0.30	1	
133.43							
311-310	CIRCULAR	0.30	0.07	0.07	0.30	1	
136.83							
C1	RECT_OPEN	0.35	2.45	0.32	7.00	1	
6095.17							
C10	ROW-R-NoPark	0.35	1.72	0.18	9.50	1	
6949.47							
C11	ROW-L-NoPark	0.35	1.72	0.19	9.50	1	
7541.87							
C12	ROW-L-NoPark	0.35	1.72	0.19	9.50	1	
6251.92							
C13	ROW-R-NoPark	0.35	1.72	0.18	9.50	1	
6054.35							
C14	ROW-L-NoPark	0.35	1.72	0.19	9.50	1	
4830.78							
C15	ROW-L-NoPark	0.35	1.72	0.19	9.50	1	
2576.19							
C16	CIRCULAR	1.00	0.79	0.25	1.00	1	
136.77							
C16_1	ROW-R-NoPark	0.35	1.72	0.18	9.50	1	
4715.32							
C16_2	ROW-R-Park	0.35	2.36	0.22	12.00	1	
7509.95							
C17	ROW-R-Park	0.35	2.36	0.22	12.00	1	
4008.73							
C18	ROW-R-NoPark	0.35	1.72	0.18	9.50	1	
4679.79							
C19	ROW-L-NoPark	0.35	1.72	0.19	9.50	1	
4833.96							
C2	ROW-R-NoPark	0.35	1.72	0.18	9.50	1	
4841.53							
C20	RECT_OPEN	0.35	1.75	0.31	5.00	1	
388.67							
C20_1	ROW-R-NoPark	0.35	1.72	0.18	9.50	1	
4169.54							
C20_2	ROW-R-Park	0.35	2.36	0.22	12.00	1	
6644.47							

C21	ROW-L-NoPark	0.35	1.72	0.19	9.50	1
4478.17						
C22	ROW-L-Park	0.35	2.36	0.23	12.00	1
4025.51						
C23	ROW-R-NoPark	0.35	1.72	0.18	9.50	1
2467.90						
C24	ROW-R-Park	0.35	2.36	0.22	12.00	1
6831.88						
C25	ROW-L-NoPark	0.35	1.72	0.19	9.50	1
4432.61						
C26	RECT_OPEN	0.35	1.75	0.31	5.00	1
388.67						
C26_1	ROW-R-Park	0.35	2.36	0.22	12.00	1
7266.70						
C26_2	ROW-R-NoPark	0.35	1.72	0.18	9.50	1
4556.76						
C27	ROW-L-NoPark	0.35	1.72	0.19	9.50	1
4723.43						
C28	ROW-L-NoPark	0.35	1.72	0.19	9.50	1
2654.32						
C29	ROW-L-NoPark	0.35	1.72	0.19	9.50	1
2605.88						
C3	ROW-L-NoPark	0.35	1.72	0.19	9.50	1
4995.30						
C30	ROW-R-NoPark	0.35	1.72	0.18	9.50	1
1617.47						
C31	ROW-R-NoPark	0.35	1.72	0.18	9.50	1
2708.36						
C32	RECT_OPEN	0.35	1.75	0.31	5.00	1
388.67						
C4	ROW-L-NoPark	0.35	1.72	0.19	9.50	1
6663.03						
C5	ROW-R-NoPark	0.35	1.72	0.18	9.50	1
6452.33						
C6	ROW-L-NoPark	0.35	1.72	0.19	9.50	1
7841.13						
C7	RECT_OPEN	0.35	2.45	0.32	7.00	1
9151.84						
C7_1	ROW-R-Park	0.35	2.36	0.22	12.00	1
11533.26						
C7_2	ROW-R-NoPark	0.35	1.72	0.18	9.50	1
7238.83						
C8	ROW-R-NoPark	0.35	1.72	0.18	9.50	1
7303.33						
C9	ROW-R-NoPark	0.35	1.72	0.18	9.50	1
6333.69						
ParkSwale	TRIANGULAR	0.30	0.27	0.14	1.80	1
210.86						
STM-206_(STM)	CIRCULAR	0.30	0.07	0.07	0.30	1
131.52						
STM-211_(1)_(STM)	CIRCULAR	0.30	0.07	0.07	0.30	1
188.02						
STM-211_(STM)	CIRCULAR	0.30	0.07	0.07	0.30	1
186.81						
STM-263_(STM)	CIRCULAR	0.30	0.07	0.07	0.30	1
125.73						
STM-264_(STM)	CIRCULAR	0.30	0.07	0.07	0.30	1
218.97						

```

*****
Transect Summary
*****

Transect ROW-L-NoPark
Area:
    0.0005  0.0020  0.0045  0.0080  0.0125
    0.0180  0.0245  0.0320  0.0404  0.0499
    0.0604  0.0719  0.0844  0.0979  0.1121
    0.1263  0.1406  0.1549  0.1692  0.1834
    0.1977  0.2124  0.2297  0.2485  0.2681
    0.2883  0.3094  0.3312  0.3537  0.3770
    0.4010  0.4258  0.4513  0.4776  0.5046
    0.5324  0.5609  0.5902  0.6202  0.6510
    0.6825  0.7148  0.7478  0.7816  0.8161
    0.8514  0.8874  0.9242  0.9617  1.0000

Hrad:
    0.0182  0.0364  0.0546  0.0727  0.0909
    0.1091  0.1273  0.1455  0.1637  0.1818
    0.2000  0.2182  0.2364  0.2546  0.2853
    0.3210  0.3566  0.3920  0.4273  0.4625
    0.4975  0.4819  0.4544  0.4893  0.5222
    0.5533  0.5828  0.6108  0.6374  0.6626
    0.6867  0.7096  0.7315  0.7524  0.7725
    0.7917  0.8102  0.8279  0.8450  0.8615
    0.8774  0.8927  0.9076  0.9219  0.9359
    0.9494  0.9626  0.9754  0.9879  1.0000

Width:
    0.0258  0.0517  0.0775  0.1034  0.1292
    0.1550  0.1809  0.2067  0.2325  0.2584
    0.2842  0.3101  0.3359  0.3617  0.3692
    0.3692  0.3693  0.3693  0.3694  0.3694
    0.3695  0.4112  0.4765  0.4958  0.5152
    0.5346  0.5540  0.5734  0.5928  0.6122
    0.6316  0.6510  0.6704  0.6898  0.7091
    0.7285  0.7479  0.7673  0.7867  0.8061
    0.8255  0.8449  0.8643  0.8837  0.9030
    0.9224  0.9418  0.9612  0.9806  1.0000

Transect ROW-L-Park
Area:
    0.0009  0.0035  0.0079  0.0141  0.0221
    0.0318  0.0433  0.0561  0.0697  0.0841
    0.0991  0.1149  0.1314  0.1487  0.1665
    0.1843  0.2021  0.2199  0.2378  0.2556
    0.2734  0.2913  0.3091  0.3269  0.3447
    0.3626  0.3804  0.3983  0.4163  0.4360
    0.4572  0.4791  0.5017  0.5251  0.5492
    0.5741  0.5997  0.6260  0.6531  0.6809
    0.7095  0.7388  0.7688  0.7996  0.8312
    0.8635  0.8965  0.9302  0.9648  1.0000

Hrad:
    0.0151  0.0302  0.0453  0.0605  0.0756
    0.0907  0.1058  0.1280  0.1505  0.1723
    0.1933  0.2138  0.2338  0.2533  0.2800
    0.3096  0.3391  0.3686  0.3980  0.4274
    0.4567  0.4859  0.5151  0.5442  0.5732
    
```

Width:

0.6021	0.6310	0.6599	0.6575	0.6219
0.6508	0.6782	0.7043	0.7290	0.7525
0.7749	0.7962	0.8165	0.8359	0.8543
0.8719	0.8887	0.9047	0.9201	0.9348
0.9489	0.9624	0.9755	0.9880	1.0000

0.0496	0.0992	0.1487	0.1983	0.2479
0.2975	0.3471	0.3717	0.3922	0.4126
0.4331	0.4535	0.4740	0.4944	0.5003
0.5003	0.5004	0.5004	0.5005	0.5005
0.5005	0.5006	0.5006	0.5007	0.5007
0.5007	0.5008	0.5008	0.5256	0.5833
0.6042	0.6250	0.6458	0.6667	0.6875
0.7083	0.7292	0.7500	0.7708	0.7917
0.8125	0.8333	0.8542	0.8750	0.8958
0.9167	0.9375	0.9583	0.9792	1.0000

Transect ROW-R-NoPark
Area:

0.0005	0.0020	0.0045	0.0080	0.0125
0.0180	0.0245	0.0320	0.0404	0.0499
0.0604	0.0719	0.0844	0.0979	0.1121
0.1263	0.1406	0.1549	0.1692	0.1834
0.1977	0.2124	0.2297	0.2485	0.2681
0.2883	0.3094	0.3312	0.3537	0.3770
0.4010	0.4258	0.4513	0.4776	0.5046
0.5324	0.5609	0.5902	0.6202	0.6510
0.6825	0.7148	0.7478	0.7816	0.8161
0.8514	0.8874	0.9242	0.9617	1.0000

Hrad:

0.0191	0.0382	0.0572	0.0763	0.0954
0.1145	0.1336	0.1526	0.1717	0.1908
0.2099	0.2290	0.2481	0.2671	0.2990
0.3358	0.3723	0.4085	0.4444	0.4801
0.5155	0.4991	0.4706	0.5060	0.5393
0.5706	0.6001	0.6280	0.6544	0.6794
0.7030	0.7255	0.7469	0.7672	0.7866
0.8051	0.8228	0.8398	0.8560	0.8716
0.8866	0.9010	0.9149	0.9283	0.9412
0.9537	0.9658	0.9776	0.9889	1.0000

Width:

0.0258	0.0517	0.0775	0.1034	0.1292
0.1550	0.1809	0.2067	0.2325	0.2584
0.2842	0.3101	0.3359	0.3617	0.3692
0.3692	0.3693	0.3693	0.3694	0.3694
0.3695	0.4112	0.4765	0.4958	0.5152
0.5346	0.5540	0.5734	0.5928	0.6122
0.6316	0.6510	0.6704	0.6898	0.7091
0.7285	0.7479	0.7673	0.7867	0.8061
0.8255	0.8449	0.8643	0.8837	0.9030
0.9224	0.9418	0.9612	0.9806	1.0000

Transect ROW-R-Park
Area:

0.0009	0.0035	0.0079	0.0141	0.0221
0.0318	0.0433	0.0561	0.0697	0.0841
0.0991	0.1149	0.1314	0.1487	0.1665

0.1843	0.2021	0.2199	0.2378	0.2556
0.2734	0.2913	0.3091	0.3269	0.3447
0.3626	0.3804	0.3983	0.4163	0.4360
0.4572	0.4791	0.5017	0.5251	0.5492
0.5741	0.5997	0.6260	0.6531	0.6809
0.7095	0.7388	0.7688	0.7996	0.8312
0.8635	0.8965	0.9302	0.9648	1.0000

Hrad:

0.0156	0.0313	0.0469	0.0625	0.0781
0.0938	0.1094	0.1323	0.1556	0.1781
0.1999	0.2210	0.2417	0.2619	0.2892
0.3195	0.3496	0.3795	0.4093	0.4390
0.4686	0.4980	0.5273	0.5564	0.5854
0.6143	0.6431	0.6718	0.6692	0.6332
0.6620	0.6892	0.7150	0.7395	0.7626
0.7846	0.8054	0.8251	0.8439	0.8617
0.8786	0.8948	0.9101	0.9248	0.9388
0.9521	0.9649	0.9771	0.9888	1.0000

Width:

0.0496	0.0992	0.1487	0.1983	0.2479
0.2975	0.3471	0.3717	0.3922	0.4126
0.4331	0.4535	0.4740	0.4944	0.5003
0.5003	0.5004	0.5004	0.5005	0.5005
0.5005	0.5006	0.5006	0.5007	0.5007
0.5007	0.5008	0.5008	0.5256	0.5833
0.6042	0.6250	0.6458	0.6667	0.6875
0.7083	0.7292	0.7500	0.7708	0.7917
0.8125	0.8333	0.8542	0.8750	0.8958
0.9167	0.9375	0.9583	0.9792	1.0000

```

*****
Analysis Options
*****
Flow Units ..... LPS
Process Models:
  Rainfall/Runoff ..... YES
  RDII ..... NO
  Snowmelt ..... NO
  Groundwater ..... NO
  Flow Routing ..... YES
  Ponding Allowed ..... NO
  Water Quality ..... NO
  Infiltration Method ..... HORTON
  Flow Routing Method ..... DYNWAVE
  Surcharge Method ..... EXTRAN
Starting Date ..... 11/21/2022 00:00:00
Ending Date ..... 11/22/2022 00:00:00
Antecedent Dry Days ..... 0.0
Report Time Step ..... 00:01:00
Wet Time Step ..... 00:01:00
Dry Time Step ..... 00:01:00
Routing Time Step ..... 2.00 sec
Variable Time Step ..... YES
Maximum Trials ..... 8
Number of Threads ..... 8
Head Tolerance ..... 0.001500 m

```

```

*****
Volume      Depth
Runoff Quantity Continuity  hectare-m  mm
*****
Initial LID Storage ..... 0.007      1.103
Total Precipitation ..... 0.434      71.667
Evaporation Loss ..... 0.000      0.000
Infiltration Loss ..... 0.086      14.162
Surface Runoff ..... 0.349      57.561
Final Storage ..... 0.007      1.104
Continuity Error (%) ..... -0.079
    
```

```

*****
Volume      Volume
Flow Routing Continuity  hectare-m  10^6 ltr
*****
Dry Weather Inflow ..... 0.000      0.000
Wet Weather Inflow ..... 0.349      3.486
Groundwater Inflow ..... 0.000      0.000
RDII Inflow ..... 0.000      0.000
External Inflow ..... 0.178      1.777
External Outflow ..... 0.526      5.258
Flooding Loss ..... 0.000      0.000
Evaporation Loss ..... 0.000      0.000
Exfiltration Loss ..... 0.000      0.000
Initial Stored Volume .... 0.182      1.816
Final Stored Volume ..... 0.183      1.827
Continuity Error (%) ..... -0.087
    
```

```

*****
Highest Continuity Errors
*****
Node J12 (18.26%)
Node CB020 (-4.30%)
Node CB019 (1.04%)
    
```

```

*****
Time-Step Critical Elements
*****
Link STM-211_(1)_(STM) (4.80%)
    
```

```

*****
Highest Flow Instability Indexes
*****
Link OCB017 (122)
Link OCB018 (115)
Link OCB001 (102)
Link OCB002 (102)
Link OHP01 (75)
    
```

```

*****
Most Frequent Nonconverging Nodes
    
```

```

*****
Node 300_(STM) (0.01%)
Node DR-M (0.01%)
Node J4 (0.01%)
Node J5 (0.01%)
Node MHST27978 (0.01%)
    
```

```

*****
Routing Time Step Summary
*****
Minimum Time Step      : 0.83 sec
Average Time Step      : 1.99 sec
Maximum Time Step      : 2.00 sec
% of Time in Steady State : 0.00
Average Iterations per Step : 2.00
% of Steps Not Converging : 0.01
Time Step Frequencies :
2.000 - 1.516 sec      : 99.99 %
1.516 - 1.149 sec      : 0.00 %
1.149 - 0.871 sec      : 0.00 %
0.871 - 0.660 sec      : 0.00 %
0.660 - 0.500 sec      : 0.00 %
    
```

```

*****
Subcatchment Runoff Summary
*****
    
```

Perv	Total Runoff mm	Total Runoff mm	Total Precip Runoff mm	Total Peak Runoff mm	Total Runoff Coeff	Total Evap mm	Total Infil mm	Imperv Runoff mm
A01a	4.79	64.37	0.05	71.67	0.00	0.00	7.41	59.58
A01b	13.76	49.65	0.06	38.24	0.898	0.00	22.10	35.89
A02a	7.32	60.44	0.03	71.67	0.00	0.00	11.34	53.12
A02b	6.45	61.73	0.04	20.54	0.843	0.00	10.06	55.27
A03a	3.68	66.13	0.02	71.67	0.00	0.00	5.66	62.45
A03b	5.90	62.61	0.03	16.08	0.923	0.00	9.17	56.71
A04a	1.70	69.16	0.06	71.67	0.00	0.00	2.61	67.46
A04b	6.43	61.70	0.04	40.34	0.965	0.00	10.08	55.27
A05a	0.00	71.77	0.06	71.67	0.00	0.00	0.00	71.77
A05b	5.90	62.61	0.04	38.69	1.001	0.00	9.18	56.71
				71.67	0.00			
				32.68	0.874			

A06a			71.67	0.00	0.00	0.00	71.78
0.00	71.78	0.03	20.83	1.002			
A06b			71.67	0.00	0.00	10.06	55.27
6.45	61.73	0.02	18.67	0.861			
B01a			71.67	0.00	0.00	4.79	63.88
3.11	66.99	0.07	48.36	0.935			
B01b			71.67	0.00	0.00	6.09	61.73
3.96	65.70	0.03	24.32	0.917			
B02a			71.67	0.00	0.00	3.91	65.32
2.55	67.88	0.02	14.21	0.947			
B02b			71.67	0.00	0.00	0.00	71.78
0.00	71.78	0.01	8.93	1.002			
B03a			71.67	0.00	0.00	3.05	66.75
1.98	68.73	0.09	67.79	0.959			
B03b			71.67	0.00	0.00	14.81	47.35
9.60	56.96	0.03	25.51	0.795			
B04a			71.67	0.00	0.00	0.00	71.74
0.00	71.74	0.01	3.47	1.001			
B04b			71.67	0.00	0.00	15.69	45.92
10.16	56.08	0.01	5.18	0.783			
B-05			71.67	0.00	0.00	2.61	67.46
1.70	69.16	0.09	63.95	0.965			
BLDG01			71.67	0.00	0.00	0.00	71.72
0.00	71.72	0.11	74.79	1.001			
P01-1			71.67	0.00	0.00	29.77	31.57
41.97	41.97	0.04	34.88	0.586			
P01-2			71.67	0.00	0.00	22.60	42.35
49.18	49.18	0.02	14.54	0.686			
PH02			71.67	0.00	0.00	18.37	43.04
10.30	53.35	0.22	155.27	0.744			
PH03			71.67	0.00	0.00	44.16	7.18
20.35	27.53	0.04	19.72	0.384			
PH04			71.67	0.00	0.00	0.00	71.69
0.00	71.69	0.17	115.84	1.000			
PH05			71.67	0.00	0.00	8.74	58.08
4.89	62.97	0.39	269.32	0.879			
PH06			71.67	0.00	0.00	12.94	51.63
7.14	58.77	0.28	193.88	0.820			
PH07			71.67	0.00	0.00	14.21	49.49
8.02	57.50	0.18	125.71	0.802			
PH08			71.67	0.00	0.00	15.00	48.06
8.66	56.72	0.18	134.12	0.791			
PH09			71.67	0.00	0.00	10.85	55.21
5.64	60.85	0.37	245.37	0.849			
PH10			71.67	0.00	0.00	15.97	48.04
7.68	55.72	0.35	229.40	0.778			
PH11			71.67	0.00	0.00	10.80	54.51
6.41	60.92	0.12	88.93	0.850			
xD-02			71.67	0.00	0.00	0.00	71.78
0.00	71.78	0.00	1.98	1.002			
xD-04			71.67	0.00	0.00	44.09	0.00
27.65	27.65	0.00	4.12	0.386			
xPARK01			71.67	0.00	0.00	36.38	20.81
35.33	35.33	0.18	119.47	0.493			

Node Depth Summary

Node	Type	Average Depth Meters	Maximum Depth Meters	Maximum HGL Meters	Time of Max Occurrence days hr:min	Reported Max Depth Meters
495_(STM)	JUNCTION	0.02	0.04	99.40	0 02:02	0.04
502_(STM)	JUNCTION	0.13	0.18	97.90	0 01:53	0.18
503_(STM)	JUNCTION	0.37	0.38	99.37	0 00:00	0.38
573_(STM)	JUNCTION	0.61	0.65	99.40	0 00:00	0.62
CB001	JUNCTION	1.36	1.48	94.15	0 01:10	1.48
CB002	JUNCTION	1.26	1.38	94.15	0 01:10	1.38
CB003	JUNCTION	0.00	0.05	94.93	0 01:10	0.05
CB004	JUNCTION	0.00	0.06	94.94	0 01:10	0.06
CB005	JUNCTION	0.00	0.04	96.34	0 01:10	0.04
CB006	JUNCTION	0.00	0.05	96.35	0 01:10	0.05
CB007	JUNCTION	0.00	0.04	97.71	0 01:10	0.04
CB008	JUNCTION	0.00	0.04	97.71	0 01:10	0.04
CB009	JUNCTION	0.00	0.03	99.79	0 01:10	0.03
CB010	JUNCTION	0.00	0.04	99.80	0 01:10	0.04
CB011	JUNCTION	0.00	0.03	101.40	0 01:10	0.03
CB012	JUNCTION	0.00	0.03	101.40	0 01:10	0.03
CB013	JUNCTION	1.36	1.40	94.64	0 01:10	1.40
CB014	JUNCTION	1.36	1.40	94.64	0 01:10	1.40
CB015	JUNCTION	0.00	0.02	95.44	0 01:10	0.02
CB016	JUNCTION	0.00	0.02	95.44	0 01:10	0.02
CB017	JUNCTION	0.87	1.94	95.84	0 01:11	1.94
CB018	JUNCTION	0.87	1.94	95.84	0 01:11	1.94
CB019	JUNCTION	0.00	0.01	96.81	0 01:08	0.01
CB020	JUNCTION	0.00	0.02	96.82	0 01:10	0.02
CB021	JUNCTION	0.04	1.41	96.76	0 01:12	1.41
CB110	JUNCTION	1.14	1.42	94.31	0 01:11	1.41
CB112	JUNCTION	1.27	1.31	94.63	0 01:10	1.31
J1	JUNCTION	0.05	0.09	94.64	0 01:10	0.09
J10	JUNCTION	0.00	0.03	94.49	0 01:10	0.03
J11	JUNCTION	0.00	0.03	94.94	0 01:10	0.03
J12	JUNCTION	0.00	0.01	96.38	0 01:13	0.01
J13	JUNCTION	0.00	0.00	96.95	0 00:00	0.00
J2	JUNCTION	0.00	0.00	95.84	0 00:00	0.00
J3	JUNCTION	0.00	0.00	95.84	0 00:00	0.00
J6	JUNCTION	0.01	0.25	96.04	0 01:13	0.25
J7	JUNCTION	0.00	0.05	97.21	0 01:10	0.05
J8	JUNCTION	0.00	0.00	97.16	0 00:00	0.00
J9	JUNCTION	0.00	0.04	98.35	0 01:08	0.04
300_(STM)	OUTFALL	2.62	2.62	94.74	0 00:00	2.62
DR-M	OUTFALL	0.00	0.00	0.00	0 00:00	0.00
J4	OUTFALL	0.00	0.00	101.95	0 00:00	0.00
J5	OUTFALL	0.00	0.00	101.95	0 00:00	0.00
MHST27978	OUTFALL	0.58	0.58	97.86	0 00:00	0.58
MHST27980	OUTFALL	1.46	1.46	99.36	0 00:00	1.46
MHST47195	OUTFALL	2.53	2.53	94.03	0 00:00	2.53
OF1	OUTFALL	0.00	0.07	94.14	0 01:10	0.07
OF2	OUTFALL	0.00	0.06	94.13	0 01:10	0.06
OF3	OUTFALL	0.04	0.08	94.63	0 01:10	0.08
OF4	OUTFALL	0.03	0.06	94.61	0 01:10	0.06
MH101	STORAGE	1.80	1.86	94.09	0 01:11	1.86
MH102	STORAGE	1.76	1.83	94.10	0 01:11	1.83
MH103	STORAGE	1.61	1.72	94.14	0 01:10	1.72

MH104	STORAGE	1.45	1.68	94.26	0	01:11	1.68
MH105	STORAGE	0.16	0.68	94.56	0	01:10	0.67
MH106	STORAGE	0.01	0.32	94.67	0	01:10	0.30
MH107	STORAGE	0.01	0.16	95.04	0	01:10	0.16
MH108	STORAGE	0.01	0.12	96.01	0	01:10	0.12
MH109	STORAGE	0.00	0.07	98.70	0	01:10	0.07
MH301	STORAGE	2.12	2.13	94.75	0	01:10	2.13
MH302	STORAGE	2.04	2.05	94.75	0	01:10	2.05
MH303	STORAGE	1.99	2.00	94.75	0	01:10	2.00
MH304	STORAGE	1.94	1.95	94.75	0	01:02	1.95
MH305	STORAGE	1.85	1.87	94.76	0	01:02	1.86
MH306	STORAGE	1.73	1.76	94.77	0	01:02	1.76
MH307	STORAGE	1.67	1.72	94.79	0	01:10	1.72
MH308	STORAGE	1.41	1.52	94.85	0	01:10	1.52
MH309	STORAGE	1.00	1.13	94.87	0	01:10	1.13
MH310	STORAGE	0.72	0.87	94.89	0	01:10	0.87
MH311	STORAGE	0.00	0.04	94.93	0	01:10	0.04
PH01-STOR	STORAGE	1.16	1.88	94.88	0	01:51	1.88
PH02-STOR	STORAGE	1.14	1.87	94.87	0	01:46	1.87
PH03-STOR	STORAGE	0.08	0.86	95.26	0	01:52	0.86
PH04-STOR	STORAGE	0.41	1.53	101.03	0	02:02	1.53
PH05-STOR	STORAGE	0.61	1.64	100.64	0	01:57	1.64
PH06-STOR	STORAGE	0.47	1.70	99.50	0	01:52	1.70
PH07-STOR	STORAGE	0.66	1.93	96.23	0	01:49	1.93
PH08-STOR	STORAGE	1.18	1.86	95.56	0	01:53	1.86
PH09-STOR	STORAGE	1.37	1.97	95.47	0	02:00	1.97
PH10-STOR	STORAGE	1.36	1.95	95.45	0	01:59	1.95
PH11-STOR	STORAGE	1.35	1.75	95.25	0	02:00	1.75
SU1	STORAGE	0.00	0.00	93.00	0	00:00	0.00

Node Inflow Summary

Total	Flow		Maximum	Maximum		Lateral	
Inflow	Balance		Lateral	Total	Time of Max	Inflow	
Volume	Error	Type	Inflow	Inflow	Occurrence	Volume	
Node	Percent		LPS	LPS	days hr:min	10^6 ltr	10^6
ltr							
495_(STM)		JUNCTION	0.00	7.73	0 02:02	0	
0.173	0.016						
502_(STM)		JUNCTION	0.00	43.91	0 01:54	0	
0.872	0.504						
503_(STM)		JUNCTION	0.00	0.07	0 00:01	0	
0.00041	16.638						
573_(STM)		JUNCTION	0.00	18.44	0 01:57	0	
0.39	-0.013						
CB001		JUNCTION	38.24	109.23	0 01:10	0.0509	
0.0999	0.052						
CB002		JUNCTION	49.44	100.11	0 01:10	0.0566	
0.000	0.000						

CB003		JUNCTION	20.54	46.52	0 01:10	0.026	
0.0508	-0.037						
CB004		JUNCTION	32.56	70.78	0 01:10	0.042	
0.0719	-0.397						
CB005		JUNCTION	16.08	45.39	0 01:10	0.0218	
0.0554	0.003						
CB006		JUNCTION	22.11	57.85	0 01:10	0.0288	
0.0615	-0.053						
CB007		JUNCTION	40.34	75.76	0 01:10	0.0567	
0.101	-0.022						
CB008		JUNCTION	31.51	55.26	0 01:10	0.0407	
0.0651	-0.006						
CB009		JUNCTION	38.69	48.49	0 01:10	0.056	
0.0676	-0.063						
CB010		JUNCTION	32.68	41.26	0 01:10	0.0426	
0.0514	-0.010						
CB011		JUNCTION	20.83	20.83	0 01:10	0.0301	
0.0301	-0.017						
CB012		JUNCTION	18.67	18.67	0 01:10	0.0241	
0.0241	-0.014						
CB013		JUNCTION	48.36	72.95	0 01:10	0.0663	
1.69	-0.000						
CB014		JUNCTION	24.32	66.27	0 01:10	0.0328	
1.46	0.001						
CB015		JUNCTION	14.21	14.21	0 01:10	0.0197	
0.0197	-0.168						
CB016		JUNCTION	8.93	8.93	0 01:10	0.0129	
0.0129	-0.105						
CB017		JUNCTION	67.79	67.90	0 01:10	0.0949	
0.0965	0.116						
CB018		JUNCTION	25.51	65.80	0 01:09	0.0308	
0.0434	0.188						
CB019		JUNCTION	3.47	28.89	0 01:10	0.00502	
0.0351	1.047						
CB020		JUNCTION	5.18	5.18	0 01:10	0.00617	
0.00617	-4.120						
CB021		JUNCTION	63.95	90.19	0 01:10	0.0899	
0.121	-0.312						
CB110		JUNCTION	0.00	103.74	0 01:13	0	
0.184	0.000						
CB112		JUNCTION	0.00	37.92	0 01:10	0	
0.747	0.001						
J1		JUNCTION	0.00	38.20	0 01:10	0	
0.746	-0.000						
J10		JUNCTION	0.00	27.07	0 01:10	0	
0.0204	-0.361						
J11		JUNCTION	0.00	7.94	0 01:10	0	
0.00895	0.485						
J12		JUNCTION	0.00	0.51	0 01:10	0	
0.000393	22.333						
J13		JUNCTION	0.00	0.00	0 00:00	0	
0	0.000 ltr						
J2		JUNCTION	0.00	0.00	0 00:00	0	
0	0.000 ltr						
J3		JUNCTION	0.00	0.00	0 00:00	0	
0	0.000 ltr						
J6		JUNCTION	119.47	119.47	0 01:10	0.183	
0.183	-0.021						
J7		JUNCTION	0.00	25.42	0 01:10	0	
0.0301	0.012						

J8		JUNCTION	0.00	0.00	0	00:00	0
0	0.000 ltr						
J9		JUNCTION	0.00	35.42	0	01:10	0
0.0442	0.118						
300_ (STM)		OUTFALL	0.00	117.05	0	01:10	0
2.08	0.000						
DR-M		OUTFALL	6.11	6.11	0	01:10	0.00583
0.00583	0.000						
J4		OUTFALL	0.00	0.00	0	00:00	0
0	0.000 ltr						
J5		OUTFALL	0.00	0.00	0	00:00	0
0	0.000 ltr						
MHST27978		OUTFALL	0.00	64.84	0	01:54	0
1.29	0.000						
MHST27980		OUTFALL	0.00	18.43	0	01:58	0
0.389	0.000						
MHST47195		OUTFALL	0.00	272.39	0	01:11	0
0.971	0.000						
OF1		OUTFALL	0.00	44.91	0	01:10	0
0.0254	0.000						
OF2		OUTFALL	0.00	101.05	0	01:10	0
0.0582	0.000						
OF3		OUTFALL	0.00	65.12	0	01:10	0
1.46	0.000						
OF4		OUTFALL	0.00	37.80	0	01:10	0
0.746	0.000						
MH101		STORAGE	0.00	272.37	0	01:11	0
0.974	-0.000						
MH102		STORAGE	0.00	272.34	0	01:11	0
0.975	0.000						
MH103		STORAGE	0.00	273.18	0	01:11	0
0.986	0.004						
MH104		STORAGE	0.00	264.40	0	01:11	0
0.726	-0.017						
MH105		STORAGE	0.00	130.34	0	01:08	0
0.255	-0.063						
MH106		STORAGE	0.00	92.95	0	01:09	0
0.193	-0.077						
MH107		STORAGE	0.00	92.02	0	01:10	0
0.154	0.105						
MH108		STORAGE	0.00	51.61	0	01:10	0
0.0842	0.001						
MH109		STORAGE	0.00	21.10	0	01:10	0
0.0338	-0.002						
MH301		STORAGE	0.00	117.03	0	01:10	0
2.09	-0.001						
MH302		STORAGE	0.00	117.01	0	01:10	0
2.14	0.003						
MH303		STORAGE	0.00	103.42	0	01:10	0
1.84	-0.000						
MH304		STORAGE	0.00	125.23	0	01:10	0
2.54	0.000						
MH305		STORAGE	0.00	121.36	0	01:10	0
1.01	0.003						
MH306		STORAGE	0.00	108.43	0	01:10	0
0.641	0.000						
MH307		STORAGE	0.00	108.38	0	01:10	0
0.641	0.000						
MH308		STORAGE	0.00	91.00	0	01:11	0
0.439	-0.006						

MH309		STORAGE	0.00	53.51	0	01:11	0
0.308	0.001						
MH310		STORAGE	0.00	45.95	0	01:10	0
0.131	-0.001						
MH311		STORAGE	0.00	5.77	0	01:10	0
0.00875	0.001						
PH01-STOR		STORAGE	124.21	124.21	0	01:10	0.168
0.308	-0.002						
PH02-STOR		STORAGE	155.27	155.27	0	01:10	0.217
0.398	-0.000						
PH03-STOR		STORAGE	19.72	19.72	0	01:10	0.0388
0.039	-0.000						
PH04-STOR		STORAGE	115.84	115.84	0	01:10	0.173
0.174	0.000						
PH05-STOR		STORAGE	269.32	269.32	0	01:10	0.389
0.467	-0.000						
PH06-STOR		STORAGE	193.88	193.88	0	01:10	0.277
0.285	0.000						
PH07-STOR		STORAGE	125.71	125.71	0	01:10	0.177
0.212	-0.001						
PH08-STOR		STORAGE	134.12	134.12	0	01:10	0.184
0.353	-0.000						
PH09-STOR		STORAGE	245.37	245.37	0	01:10	0.366
0.802	-0.002						
PH10-STOR		STORAGE	229.40	229.40	0	01:10	0.35
0.769	-0.003						
PH11-STOR		STORAGE	88.93	88.93	0	01:10	0.122
0.34	-0.001						
SU1		STORAGE	0.00	0.00	0	00:00	0
0	0.000 ltr						

Node Surcharge Summary

Surcharging occurs when water rises above the top of the highest conduit.

Node	Type	Hours Surcharged	Max. Height Above Crown Meters	Min. Depth Below Rim Meters
503_ (STM)	JUNCTION	24.00	0.083	1.947
573_ (STM)	JUNCTION	24.00	0.079	1.094
MH101	STORAGE	24.00	1.172	0.000
MH102	STORAGE	24.00	1.149	0.000
MH103	STORAGE	24.00	1.119	0.000
MH301	STORAGE	24.00	1.372	0.000
MH302	STORAGE	24.00	1.343	0.000
MH303	STORAGE	24.00	1.295	0.000
MH304	STORAGE	24.00	1.273	0.000
MH305	STORAGE	24.00	1.265	0.000

Node Flooding Summary

No nodes were flooded.

Storage Volume Summary

Max Occurrence	Maximum Outflow Storage Unit hr:min LPS	Average Volume 1000 m³	Avg Pcnt Full	Evap Pcnt Loss	Exfil Pcnt Loss	Maximum Volume 1000 m³	Max Pcnt Full	Time of days
MH101	01:04 272.39	0.003	98.4	0.0	0.0	0.003	100.0	0
MH102	01:07 272.37	0.004	97.3	0.0	0.0	0.005	100.0	0
MH103	01:01 273.76	0.003	98.2	0.0	0.0	0.003	100.0	0
MH104	01:11 266.06	0.003	69.2	0.0	0.0	0.003	79.9	0
MH105	01:10 128.01	0.000	5.8	0.0	0.0	0.001	25.2	0
MH106	01:10 91.54	0.000	0.4	0.0	0.0	0.000	11.2	0
MH107	01:10 92.02	0.000	0.2	0.0	0.0	0.000	5.1	0
MH108	01:10 51.60	0.000	0.2	0.0	0.0	0.000	4.3	0
MH109	01:10 21.08	0.000	0.1	0.0	0.0	0.000	2.5	0
MH301	00:00 117.05	0.002	100.0	0.0	0.0	0.002	100.0	0
MH302	00:00 117.03	0.002	100.0	0.0	0.0	0.002	100.0	0
MH303	00:00 103.44	0.002	100.0	0.0	0.0	0.002	100.0	0
MH304	00:00 125.27	0.002	100.0	0.0	0.0	0.002	100.0	0
MH305	00:00 121.38	0.002	100.0	0.0	0.0	0.002	100.0	0
MH306	01:02 108.57	0.002	84.4	0.0	0.0	0.002	85.9	0
MH307	01:10 108.43	0.002	63.5	0.0	0.0	0.002	65.3	0
MH308	01:10 91.73	0.002	55.6	0.0	0.0	0.002	59.8	0
MH309	01:10 53.81	0.001	39.7	0.0	0.0	0.001	44.6	0
MH310	01:10 45.77	0.001	29.2	0.0	0.0	0.001	35.2	0
MH311	01:10 5.77	0.000	0.1	0.0	0.0	0.000	1.8	0
PH01-STOR	01:51 9.60	0.157	38.6	0.0	0.0	0.254	62.7	0

PH02-STOR	01:46 13.82	0.201	57.2	0.0	0.0	0.329	93.5	0
PH03-STOR	01:52 4.20	0.002	3.8	0.0	0.0	0.023	43.2	0
PH04-STOR	02:02 7.73	0.034	20.6	0.0	0.0	0.124	76.5	0
PH05-STOR	01:57 18.41	0.133	30.7	0.0	0.0	0.355	82.0	0
PH06-STOR	01:52 14.96	0.057	23.4	0.0	0.0	0.207	84.9	0
PH07-STOR	01:49 10.26	0.054	33.1	0.0	0.0	0.157	96.6	0
PH08-STOR	01:53 8.88	0.192	59.2	0.0	0.0	0.301	92.8	0
PH09-STOR	02:00 17.37	0.482	68.6	0.0	0.0	0.691	98.3	0
PH10-STOR	01:59 18.26	0.459	67.8	0.0	0.0	0.658	97.4	0
PH11-STOR	02:00 4.89	0.237	67.4	0.0	0.0	0.308	87.6	0
SU1	00:00 0.00	0.000	0.0	0.0	0.0	0.000	0.0	0

Outfall Loading Summary

Outfall Node	Flow Freq Pcnt	Avg Flow LPS	Max Flow LPS	Total Volume 10^6 ltr
300_(STM)	99.97	24.20	117.05	2.084
DR-M	12.63	0.54	6.11	0.006
J4	0.00	0.00	0.00	0.000
J5	0.00	0.00	0.00	0.000
MHST27978	99.13	15.20	64.84	1.290
MHST27980	70.63	6.43	18.43	0.389
MHST47195	52.46	21.68	272.39	0.971
OF1	2.24	13.23	44.91	0.025
OF2	2.34	29.05	101.05	0.058
OF3	100.00	16.96	65.12	1.465
OF4	100.00	8.64	37.80	0.746
System	49.04	135.93	698.27	7.034

Link Flow Summary

Link	Type	Maximum Flow LPS	Time of Max Occurrence days hr:min	Maximum Veloc m/sec	Max/ Full Flow	Max/ Full Depth
101-MV	CONDUIT	272.39	0 01:11	0.76	0.60	1.00

102-101	CONDUIT	272.37	0	01:11	0.76	0.63	1.00
103-102	CONDUIT	272.34	0	01:11	0.96	0.79	1.00
104-103	CONDUIT	266.06	0	01:11	1.23	1.20	1.00
105-104	CONDUIT	128.01	0	01:08	1.16	0.52	1.00
106-105	CONDUIT	91.54	0	01:08	1.56	0.55	1.00
107-106	CONDUIT	92.02	0	01:10	2.34	0.55	0.76
108-107	CONDUIT	51.60	0	01:10	2.06	0.31	0.38
109-108	CONDUIT	21.08	0	01:10	1.62	0.13	0.24
301-MV	CONDUIT	117.05	0	01:10	0.26	0.22	1.00
302-301	CONDUIT	117.03	0	01:10	0.33	1.57	1.00
303-302	CONDUIT	103.44	0	01:10	0.29	0.27	1.00
304-303	CONDUIT	103.42	0	01:10	0.29	0.30	1.00
305-304	CONDUIT	121.38	0	01:10	0.43	0.49	1.00
306-305	CONDUIT	108.57	0	01:10	0.50	0.54	1.00
307-306	CONDUIT	108.43	0	01:10	0.50	0.57	1.00
308-307	CONDUIT	91.73	0	01:11	0.58	0.59	1.00
309-308	CONDUIT	53.81	0	01:11	0.49	0.25	1.00
310-309	CONDUIT	45.77	0	01:10	0.65	0.34	1.00
311-310	CONDUIT	5.77	0	01:10	0.14	0.04	0.57
C1	CONDUIT	26.25	0	01:08	0.20	0.00	0.24
C10	CHANNEL	0.00	0	00:00	0.00	0.00	0.06
C11	CHANNEL	35.75	0	01:10	0.94	0.00	0.13
C12	CHANNEL	38.24	0	01:10	0.74	0.01	0.15
C13	CHANNEL	25.97	0	01:10	0.73	0.00	0.13
C14	CHANNEL	50.71	0	01:10	0.21	0.01	0.34
C15	CHANNEL	44.91	0	01:10	0.18	0.02	0.35
C16	CONDUIT	0.00	0	00:00	0.00	0.00	0.50
C16_1	CHANNEL	27.07	0	01:10	0.89	0.01	0.12
C16_2	CHANNEL	27.02	0	01:10	0.07	0.00	0.30
C17	CHANNEL	101.05	0	01:10	0.21	0.03	0.34
C18	CHANNEL	25.42	0	01:10	1.29	0.01	0.10
C19	CHANNEL	0.00	0	00:00	0.00	0.00	0.02
C2	CHANNEL	0.00	0	00:00	0.00	0.00	0.04
C20	CONDUIT	44.54	0	01:10	0.13	0.11	0.19
C20_1	CHANNEL	0.51	0	01:10	0.43	0.00	0.02
C20_2	CHANNEL	0.16	0	01:13	0.09	0.00	0.21
C21	CHANNEL	1.53	0	01:10	0.28	0.00	0.22
C22	CHANNEL	0.00	0	00:00	0.00	0.00	0.20
C23	CHANNEL	0.00	0	00:00	0.00	0.00	0.20
C24	CHANNEL	0.00	0	00:00	0.00	0.00	0.03
C25	CHANNEL	0.00	0	00:00	0.00	0.00	0.03
C26	CONDUIT	38.78	0	01:09	0.28	0.10	0.11
C26_1	CHANNEL	7.94	0	01:10	0.37	0.00	0.07
C26_2	CHANNEL	7.89	0	01:10	0.03	0.00	0.33
C27	CHANNEL	3.00	0	01:10	0.01	0.00	0.32
C28	CHANNEL	65.12	0	01:10	0.21	0.02	0.40
C29	CHANNEL	38.20	0	01:10	0.12	0.01	0.41
C3	CHANNEL	0.00	0	00:00	0.00	0.00	0.04
C30	CHANNEL	37.92	0	01:10	0.23	0.02	0.28
C31	CHANNEL	37.80	0	01:10	0.29	0.01	0.24
C32	CONDUIT	33.97	0	01:10	0.07	0.09	0.29
C4	CHANNEL	8.57	0	01:10	0.47	0.00	0.09
C5	CHANNEL	9.80	0	01:10	0.61	0.00	0.09
C6	CHANNEL	23.75	0	01:10	0.81	0.00	0.12
C7	CONDUIT	0.00	0	00:00	0.00	0.00	0.23
C7_1	CHANNEL	35.42	0	01:10	0.63	0.00	0.11
C7_2	CHANNEL	35.42	0	01:10	1.11	0.00	0.12

C8	CHANNEL	29.31	0	01:10	0.98	0.00	0.12
C9	CHANNEL	25.42	0	01:10	0.64	0.00	0.14
ParkSwale	CONDUIT	103.74	0	01:13	0.71	0.49	0.74
STM-206_(STM)	CONDUIT	104.13	0	01:13	1.47	0.79	1.00
STM-211_(1)_(STM)	CONDUIT	64.84	0	01:54	1.22	0.34	0.76
STM-211_(STM)	CONDUIT	7.73	0	02:02	0.75	0.04	0.37
STM-263_(STM)	CONDUIT	0.07	0	00:01	0.00	0.00	1.00
STM-264_(STM)	CONDUIT	18.43	0	01:58	0.26	0.08	1.00
OCB001	ORIFICE	8.72	0	01:05			1.00
OCB002	ORIFICE	12.11	0	01:05			1.00
OCB013	ORIFICE	18.94	0	01:34			1.00
OCB014	ORIFICE	5.65	0	01:34			1.00
OCB017	ORIFICE	22.45	0	01:13			1.00
OCB018	ORIFICE	14.87	0	01:13			1.00
OCB021	ORIFICE	40.35	0	01:12			1.00
OHP01	ORIFICE	9.60	0	01:53			1.00
OPH02	ORIFICE	13.82	0	01:52			1.00
OPH03	ORIFICE	4.20	0	01:52			1.00
OPH04a	ORIFICE	2.51	0	02:02			1.00
OPH04b	ORIFICE	5.23	0	02:02			1.00
OPH05a	ORIFICE	7.73	0	01:57			1.00
OPH05b	ORIFICE	10.68	0	01:57			1.00
OPH06a	ORIFICE	5.93	0	01:52			1.00
OPH06b	ORIFICE	9.03	0	01:52			1.00
OPH07	ORIFICE	10.26	0	01:42			1.00
OPH08	ORIFICE	8.88	0	01:52			1.00
OPH09	ORIFICE	17.37	0	02:02			1.00
OPH10	ORIFICE	18.26	0	02:00			1.00
OPH11	ORIFICE	4.89	0	02:02			1.00
W1	WEIR	0.00	0	00:00			0.00
OCB003	DUMMY	19.40	0	01:02			
OCB004	DUMMY	19.40	0	01:02			
OCB005	DUMMY	19.40	0	01:03			
OCB006	DUMMY	19.40	0	01:03			
OCB007	DUMMY	21.02	0	01:10			
OCB008	DUMMY	19.40	0	01:03			
OCB009	DUMMY	13.07	0	01:10			
OCB010	DUMMY	17.45	0	01:10			
OCB011	DUMMY	11.03	0	01:10			
OCB012	DUMMY	10.07	0	01:10			
OCB015	DUMMY	6.27	0	01:10			
OCB016	DUMMY	5.92	0	01:10			
OCB019	DUMMY	2.14	0	01:08			
OCB020	DUMMY	3.64	0	01:10			

Flow Classification Summary

--- Adjusted ----- Fraction of Time in Flow Class -----
--- /Actual Up Down Sub Sup Up Down Norm
Inlet
Conduit Length Dry Dry Dry Crit Crit Crit Crit Ltd
Ctrl

```

-----
----
101-MV          1.00  0.00  0.00  0.00  1.00  0.00  0.00  0.00  0.00
0.00
102-101        1.00  0.00  0.00  0.00  1.00  0.00  0.00  0.00  0.00
0.00
103-102        1.00  0.00  0.00  0.00  1.00  0.00  0.00  0.00  0.00
0.00
104-103        1.00  0.00  0.00  0.00  1.00  0.00  0.00  0.00  0.00
0.00
105-104        1.00  0.00  0.00  0.00  1.00  0.00  0.00  0.00  0.00
0.00
106-105        1.00  0.00  0.02  0.00  0.88  0.10  0.00  0.00  0.99
0.00
107-106        1.00  0.00  0.00  0.00  0.07  0.07  0.00  0.86  0.14
0.00
108-107        1.00  0.00  0.00  0.00  0.00  0.00  0.00  1.00  0.00
0.00
109-108        1.00  0.00  0.00  0.00  0.00  0.00  0.00  1.00  0.00
0.00
301-MV          1.00  0.00  0.00  0.00  1.00  0.00  0.00  0.00  0.00
0.00
302-301        1.00  0.00  0.00  0.00  1.00  0.00  0.00  0.00  0.00
0.00
303-302        1.00  0.00  0.00  0.00  1.00  0.00  0.00  0.00  0.00
0.00
304-303        1.00  0.00  0.00  0.00  1.00  0.00  0.00  0.00  0.00
0.00
305-304        1.00  0.00  0.00  0.00  1.00  0.00  0.00  0.00  0.00
0.00
306-305        1.00  0.00  0.00  0.00  1.00  0.00  0.00  0.00  0.00
0.00
307-306        1.00  0.00  0.00  0.00  1.00  0.00  0.00  0.00  0.00
0.00
308-307        1.00  0.00  0.00  0.00  1.00  0.00  0.00  0.00  0.00
0.00
309-308        1.00  0.00  0.00  0.00  1.00  0.00  0.00  0.00  0.00
0.00
310-309        1.00  0.00  0.00  0.00  1.00  0.00  0.00  0.00  0.00
0.00
311-310        1.00  0.00  0.77  0.00  0.23  0.00  0.00  0.00  0.99
0.00
C1              1.00  0.82  0.00  0.00  0.02  0.00  0.00  0.16  0.02
0.00
C10             1.00  0.83  0.17  0.00  0.00  0.00  0.00  0.00  0.00
0.00
C11             1.00  0.78  0.02  0.00  0.07  0.13  0.00  0.00  0.01
0.00
C12             1.00  0.79  0.03  0.00  0.05  0.12  0.00  0.00  0.99
0.00
C13             1.00  0.82  0.01  0.00  0.04  0.13  0.00  0.00  0.03
0.00
C14             1.00  0.00  0.81  0.00  0.19  0.00  0.00  0.00  0.99
0.00
C15             1.00  0.00  0.98  0.00  0.02  0.00  0.00  0.00  0.94
0.00
C16             1.00  0.00  0.00  0.00  1.00  0.00  0.00  0.00  0.00
0.00
C16_1           1.00  0.00  0.84  0.00  0.04  0.13  0.00  0.00  0.87
0.00
    
```

```

C16_2           1.00  0.00  0.00  0.00  1.00  0.00  0.00  0.00  1.00
0.00
C17             1.00  0.00  0.98  0.00  0.02  0.00  0.00  0.00  0.93
0.00
C18             1.00  0.00  0.00  0.00  0.84  0.16  0.00  0.00  0.83
0.00
C19             1.00  0.86  0.14  0.00  0.00  0.00  0.00  0.00  0.00
0.00
C2              1.00  0.82  0.18  0.00  0.00  0.00  0.00  0.00  0.00
0.00
C20             1.00  0.98  0.00  0.00  0.02  0.00  0.00  0.00  0.00
0.00
C20_1           1.00  0.00  0.82  0.00  0.07  0.11  0.00  0.00  0.94
0.00
C20_2           1.00  0.00  0.00  0.00  0.03  0.00  0.00  0.97  0.03
0.00
C21             1.00  0.86  0.00  0.00  0.02  0.00  0.00  0.12  0.02
0.00
C22             1.00  0.97  0.03  0.00  0.00  0.00  0.00  0.00  0.00
0.00
C23             1.00  0.98  0.02  0.00  0.00  0.00  0.00  0.00  0.00
0.00
C24             1.00  0.83  0.17  0.00  0.00  0.00  0.00  0.00  0.00
0.00
C25             1.00  0.83  0.17  0.00  0.00  0.00  0.00  0.00  0.00
0.00
C26             1.00  0.98  0.00  0.00  0.01  0.00  0.00  0.00  0.00
0.00
C26_1           1.00  0.00  0.83  0.00  0.14  0.03  0.00  0.00  0.97
0.00
C26_2           1.00  0.00  0.00  0.00  1.00  0.00  0.00  0.00  1.00
0.00
C27             1.00  0.00  0.83  0.00  0.17  0.00  0.00  0.00  0.99
0.00
C28             1.00  0.00  0.00  0.00  1.00  0.00  0.00  0.00  0.00
0.00
C29             1.00  0.00  0.00  0.00  1.00  0.00  0.00  0.00  0.00
0.00
C3              1.00  0.81  0.19  0.00  0.00  0.00  0.00  0.00  0.00
0.00
C30             1.00  0.00  0.00  0.00  1.00  0.00  0.00  0.00  0.00
0.00
C31             1.00  0.00  0.00  0.00  1.00  0.00  0.00  0.00  0.00
0.00
C32             1.00  0.00  0.00  0.00  1.00  0.00  0.00  0.00  0.00
0.00
C4              1.00  0.79  0.03  0.00  0.13  0.04  0.00  0.00  0.99
0.00
C5              1.00  0.75  0.05  0.00  0.07  0.12  0.00  0.00  0.99
0.00
C6              1.00  0.78  0.03  0.00  0.06  0.13  0.00  0.00  0.99
0.00
C7              1.00  0.98  0.02  0.00  0.00  0.00  0.00  0.00  0.00
0.00
C7_1            1.00  0.00  0.77  0.00  0.11  0.11  0.00  0.00  0.99
0.00
C7_2            1.00  0.00  0.00  0.00  0.83  0.17  0.00  0.00  0.01
0.00
C8              1.00  0.76  0.01  0.00  0.10  0.13  0.00  0.00  0.01
0.00
    
```

```

C9          1.00  0.00  0.77  0.00  0.18  0.06  0.00  0.00  0.99
0.00
ParkSwale   1.00  0.00  0.00  0.00  0.00  0.00  0.00  1.00  0.00
0.00
STM-206_(STM) 1.00  0.00  0.00  0.00  1.00  0.00  0.00  0.00  0.00
0.00
STM-211_(1)_(STM) 1.00  0.00  0.00  0.00  1.00  0.00  0.00  0.00  0.05
0.00
STM-211_(STM) 1.00  0.00  0.01  0.00  0.96  0.03  0.00  0.00  1.00
0.00
STM-263_(STM) 1.00  0.00  0.00  0.00  1.00  0.00  0.00  0.00  0.00
0.00
STM-264_(STM) 1.00  0.00  0.00  0.00  1.00  0.00  0.00  0.00  0.00
0.00
    
```

 Conduit Surcharge Summary

Conduit	Hours Full			Hours	Hours
	Both Ends	Upstream	Dnstream	Above Full Normal Flow	Capacity Limited
101-MV	24.00	24.00	24.00	0.01	0.06
102-101	24.00	24.00	24.00	0.01	0.01
103-102	24.00	24.00	24.00	0.01	0.01
104-103	24.00	24.00	24.00	0.08	0.08
105-104	0.18	0.18	24.00	0.01	0.01
106-105	0.02	0.02	0.18	0.01	0.01
107-106	0.01	0.01	0.01	0.01	0.01
301-MV	24.00	24.00	24.00	0.01	0.01
302-301	24.00	24.00	24.00	0.58	0.59
303-302	24.00	24.00	24.00	0.01	0.01
304-303	24.00	24.00	24.00	0.01	0.01
305-304	24.00	24.00	24.00	0.01	0.01
306-305	24.00	24.00	24.00	0.01	0.01
307-306	24.00	24.00	24.00	0.01	0.01
308-307	24.00	24.00	24.00	0.01	0.01
309-308	24.00	24.00	24.00	0.01	0.01
310-309	24.00	24.00	24.00	0.01	0.01
311-310	0.01	0.01	23.83	0.01	0.01
C16	0.01	0.01	24.00	0.01	0.01
STM-206_(STM)	24.00	24.00	24.00	0.01	0.01
STM-263_(STM)	24.00	24.00	24.00	0.01	0.01
STM-264_(STM)	24.00	24.00	24.00	0.01	0.01

Analysis begun on: Wed Jul 31 11:42:14 2024
 Analysis ended on: Wed Jul 31 11:42:18 2024
 Total elapsed time: 00:00:04

DRAWING NOT TO BE USED FOR CONSTRUCTION

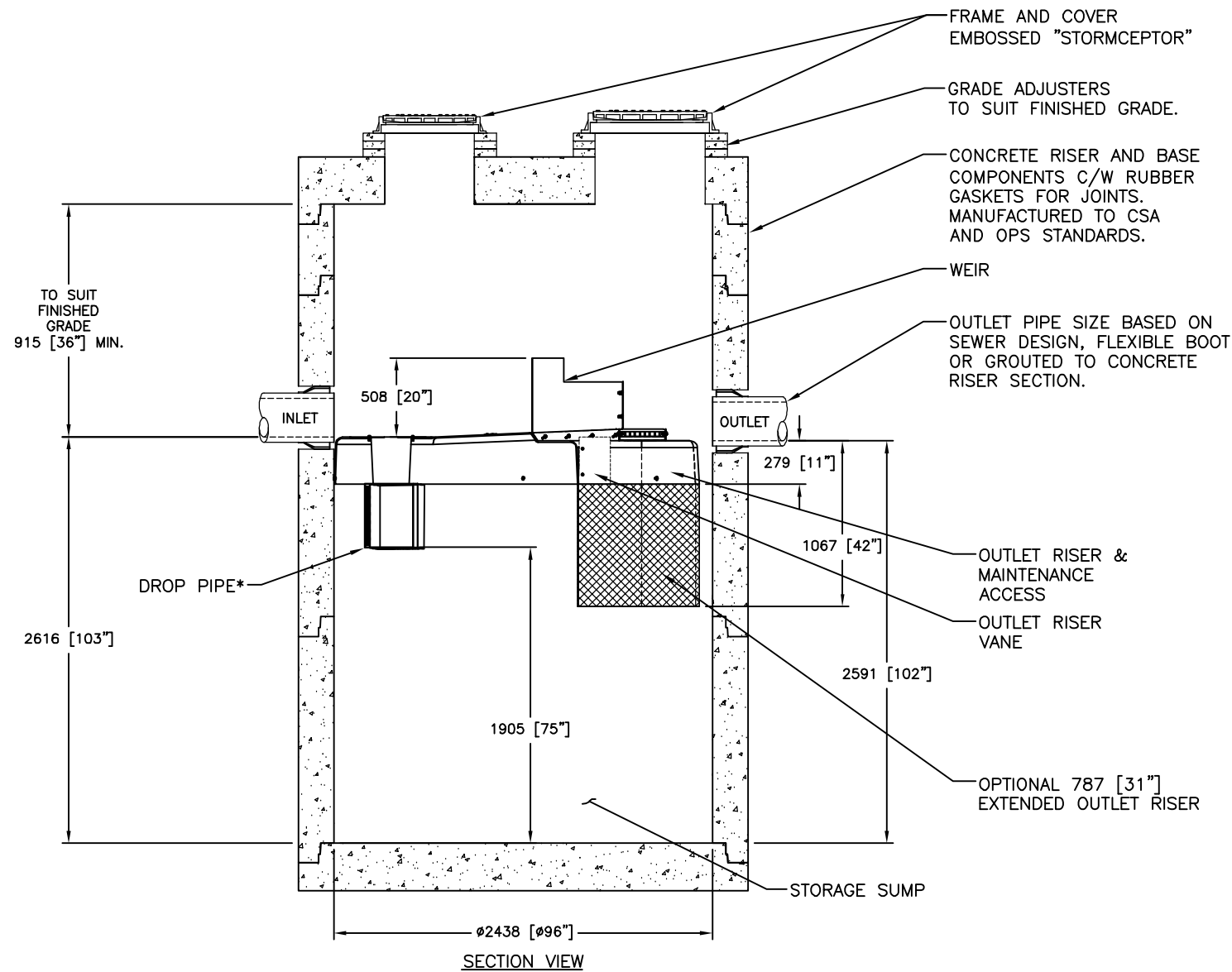

GENERAL NOTES:

- * MAXIMUM SURFACE LOADING RATE (SLR) INTO LOWER CHAMBER THROUGH DROP PIPE IS 1135 L/min/m² (27.9 gpm/ft²) FOR STORMCEPTOR EF8 AND 535 L/min/m² (13.1 gpm/ft²) FOR STORMCEPTOR EFO8 (OIL CAPTURE CONFIGURATION).
- 1. ALL DIMENSIONS INDICATED ARE IN MILLIMETERS (INCHES) UNLESS OTHERWISE SPECIFIED.
- 2. STORMCEPTOR STRUCTURE INLET AND OUTLET PIPE SIZE AND ORIENTATION SHOWN FOR INFORMATIONAL PURPOSES ONLY.
- 3. UNLESS OTHERWISE NOTED, BYPASS INFRASTRUCTURE, SUCH AS ALL UPSTREAM DIVERSION STRUCTURES, CONNECTING STRUCTURES, OR PIPE CONDUITS CONNECTING TO COMPLETE THE STORMCEPTOR SYSTEM SHALL BE PROVIDED AND ADDRESSED SEPARATELY.
- 4. DRAWING FOR INFORMATION PURPOSES ONLY. REFER TO ENGINEER'S SITE/UTILITY PLAN FOR STRUCTURE ORIENTATION.
- 5. NO PRODUCT SUBSTITUTIONS SHALL BE ACCEPTED UNLESS SUBMITTED 10 DAYS PRIOR TO PROJECT BID DATE, OR AS DIRECTED BY THE ENGINEER OF RECORD.

INSTALLATION NOTES

- A. ANY SUB-BASE, BACKFILL DEPTH, AND/OR ANTI-FLOTATION PROVISIONS ARE SITE-SPECIFIC DESIGN CONSIDERATIONS AND SHALL BE SPECIFIED BY ENGINEER OF RECORD.
- B. CONTRACTOR TO PROVIDE EQUIPMENT WITH SUFFICIENT LIFTING AND REACH CAPACITY TO LIFT AND SET THE STRUCTURE (LIFTING CLUTCHES PROVIDED)
- C. CONTRACTOR WILL INSTALL AND LEVEL THE STRUCTURE, SEALING THE JOINTS, LINE ENTRY AND EXIT POINTS (NON-SHRINK GROUT WITH APPROVED WATERSTOP OR FLEXIBLE BOOT)
- D. CONTRACTOR TO TAKE APPROPRIATE MEASURES TO PROTECT THE DEVICE FROM CONSTRUCTION-RELATED EROSION RUNOFF.
- E. DEVICE ACTIVATION, BY CONTRACTOR, SHALL OCCUR ONLY AFTER SITE HAS BEEN STABILIZED AND THE STORMCEPTOR UNIT IS CLEAN AND FREE OF DEBRIS.

FOR SITE SPECIFIC DRAWINGS PLEASE CONTACT YOUR LOCAL STORMCEPTOR REPRESENTATIVE. SITE SPECIFIC DRAWINGS ARE BASED ON THE BEST AVAILABLE INFORMATION AT THE TIME. SOME FIELD REVISIONS TO THE SYSTEM LOCATION OR CONNECTION PIPING MAY BE NECESSARY BASED ON AVAILABLE SPACE OR SITE CONFIGURATION REVISIONS. ELEVATIONS SHOULD BE MAINTAINED EXCEPT WHERE NOTED ON BYPASS STRUCTURE (IF REQUIRED).

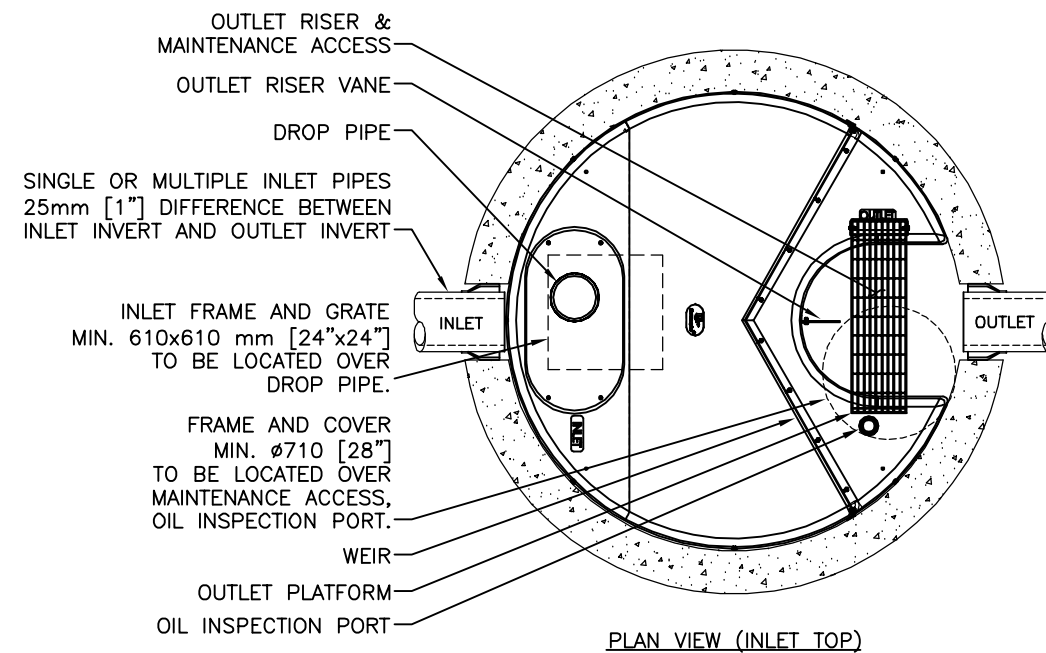
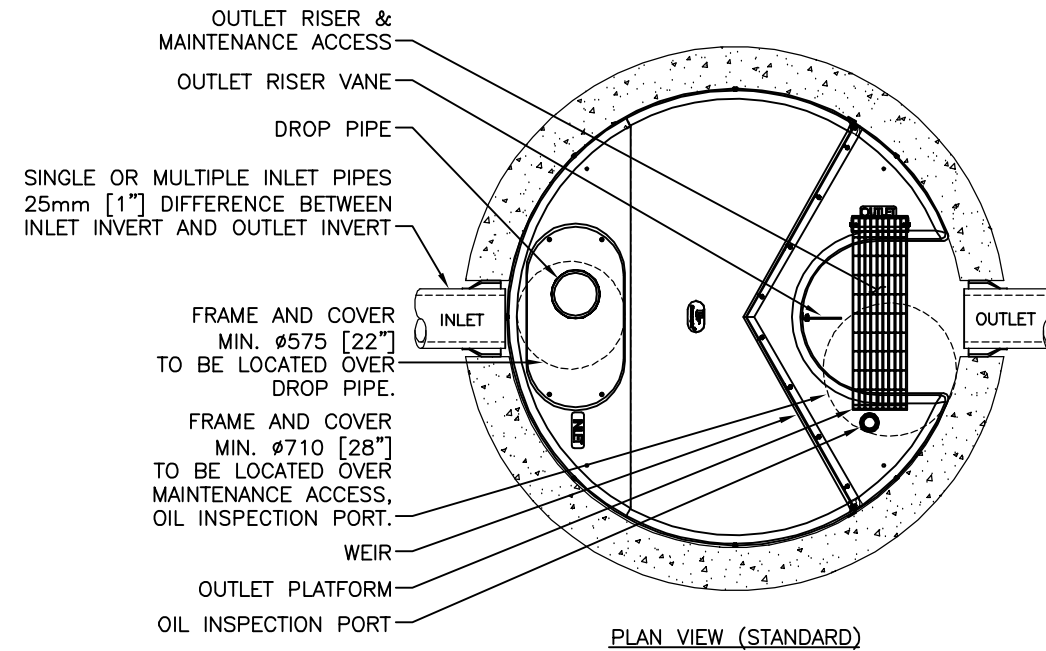

SITE SPECIFIC DATA REQUIREMENTS					
STORMCEPTOR MODEL	EFO8				
STRUCTURE ID	*				
HYDROCARBON STORAGE REQ'D (L)	*				
WATER QUALITY FLOW RATE (L/s)	*				
PEAK FLOW RATE (L/s)	*				
RETURN PERIOD OF PEAK FLOW (yrs)	*				
DRAINAGE AREA (HA)	*				
DRAINAGE AREA IMPERVIOUSNESS (%)	*				
PIPE DATA:	I.E.	MAT'L	DIA	SLOPE %	HGL
INLET #1	*	*	*	*	*
INLET #2	*	*	*	*	*
OUTLET	*	*	*	*	*
* PER ENGINEER OF RECORD					

STANDARD DETAIL NOT FOR CONSTRUCTION

This design and information is provided as a service to the product owner, engineer and contractor by Imbrium Systems ("Imbrium"). Neither the drawing, nor any part thereof, may be reproduced, stored in a retrieval system, or transmitted in any form or by any means, electronic, mechanical, photocopying, recording, or by any information storage and retrieval system, without the prior written consent of Imbrium. Failure to comply with the above conditions shall constitute an acknowledgment of the user's own risk and Imbrium expressly disclaims any liability or responsibility for such use. If discrepancies between the supplied information upon which the drawing is based and actual field conditions are discovered, the user must be responsible for immediately notifying Imbrium. Imbrium accepts no liability for designs based on missing, incomplete or inaccurate information supplied by others.

MARK	DATE	REVISION DESCRIPTION	BY
###	###/###/###	OUTLET PLATFORM	JSK
###	###/###/###	INITIAL RELEASE	JSK
###	###/###/###		
###	###/###/###		

SCALE = NTS

407 FAIRVIEW DRIVE, WHITBY, ON L1N 3J9
 TEL: 905-585-4801 CA: 416-960-9600 INTL: +1-416-960-9600
 THE ENGINEER OF RECORD IS RESPONSIBLE FOR THE ACCURACY OF THE INFORMATION PROVIDED IN THIS DRAWING. THE USER OF THIS DRAWING SHALL BE RESPONSIBLE FOR VERIFYING THE INFORMATION PROVIDED IN THIS DRAWING IS ACCURATE AND COMPLETE FOR THE PROJECT AND SITE. THE USER SHALL BE RESPONSIBLE FOR OBTAINING ALL NECESSARY PERMITS AND APPROVALS FROM THE APPROPRIATE AUTHORITIES. THE USER SHALL BE RESPONSIBLE FOR OBTAINING ALL NECESSARY INFORMATION FROM THE APPROPRIATE AUTHORITIES. THE USER SHALL BE RESPONSIBLE FOR OBTAINING ALL NECESSARY INFORMATION FROM THE APPROPRIATE AUTHORITIES.

DATE: 10/13/2017	
DESIGNED: JSK	DRAWN: JSK
CHECKED: BSF	APPROVED: *
PROJECT No.: EFO8	SEQUENCE No.: *
SHEET: 1 OF 1	

Stormceptor® EF Sizing Report

Imbrium® Systems

ESTIMATED NET ANNUAL SEDIMENT (TSS) LOAD REDUCTION

03/20/2024

Province:	Ontario
City:	Ottawa
Nearest Rainfall Station:	OTTAWA CDA RCS
Climate Station Id:	6105978
Years of Rainfall Data:	20

Project Name:	1500 Merivale (N)
Project Number:	64165
Designer Name:	Kallie Auld
Designer Company:	Novatech
Designer Email:	k.auld@novatech-eng.com
Designer Phone:	613-254-9643
EOR Name:	
EOR Company:	
EOR Email:	
EOR Phone:	

Site Name:	1500 Merivale (N)
------------	-------------------

Drainage Area (ha):	2.113
---------------------	-------

% Imperviousness:	57.00
-------------------	-------

Runoff Coefficient 'c': 0.64

Particle Size Distribution:	Fine
-----------------------------	------

Target TSS Removal (%):	80.0
-------------------------	------

Required Water Quality Runoff Volume Capture (%):	90.00
Estimated Water Quality Flow Rate (L/s):	43.78
Oil / Fuel Spill Risk Site?	Yes
Upstream Flow Control?	No
Peak Conveyance (maximum) Flow Rate (L/s):	300.00
Influent TSS Concentration (mg/L):	200
Estimated Average Annual Sediment Load (kg/yr):	1311
Estimated Average Annual Sediment Volume (L/yr):	1066

Net Annual Sediment (TSS) Load Reduction Sizing Summary	
Stormceptor Model	TSS Removal Provided (%)
EFO4	66
EFO6	80
EFO8	87
EFO10	92
EFO12	95

Recommended Stormceptor EFO Model: EFO6

Estimated Net Annual Sediment (TSS) Load Reduction (%): 80

Water Quality Runoff Volume Capture (%): > 90



THIRD-PARTY TESTING AND VERIFICATION

► **Stormceptor® EF and Stormceptor® EFO** are the latest evolutions in the Stormceptor® oil-grit separator (OGS) technology series, and are designed to remove a wide variety of pollutants from stormwater and snowmelt runoff. These technologies have been third-party tested in accordance with the Canadian ETV **Procedure for Laboratory Testing of Oil-Grit Separators** and performance has been third-party verified in accordance with the **ISO 14034 Environmental Technology Verification (ETV)** protocol.

PERFORMANCE

► **Stormceptor® EF and EFO** remove stormwater pollutants through gravity separation and floatation, and feature a patent-pending design that generates positive removal of total suspended solids (TSS) throughout each storm event, including high-intensity storms. Captured pollutants include sediment, free oils, and sediment-bound pollutants such as nutrients, heavy metals, and petroleum hydrocarbons. Stormceptor is sized to remove a high level of TSS from the frequent rainfall events that contribute the vast majority of annual runoff volume and pollutant load. The technology incorporates an internal bypass to convey excessive stormwater flows from high-intensity storms through the device without resuspension and washout (scour) of previously captured pollutants. Proper routine maintenance ensures high pollutant removal performance and protection of downstream waterways.

PARTICLE SIZE DISTRIBUTION (PSD)

► The **Canadian ETV PSD** shown in the table below was used, or in part, for this sizing. This is the identical PSD that is referenced in the Canadian ETV **Procedure for Laboratory Testing of Oil-Grit Separators** for both sediment removal testing and scour testing. The Canadian ETV PSD contains a wide range of particle sizes in the sand and silt fractions, and is considered reasonably representative of the particle size fractions found in typical urban stormwater runoff.

Particle Size (µm)	Percent Less Than	Particle Size Fraction (µm)	Percent
1000	100	500-1000	5
500	95	250-500	5
250	90	150-250	15
150	75	100-150	15
100	60	75-100	10
75	50	50-75	5
50	45	20-50	10
20	35	8-20	15
8	20	5-8	10
5	10	2-5	5
2	5	<2	5

Stormceptor® EF Sizing Report

Rainfall Intensity (mm / hr)	Percent Rainfall Volume (%)	Cumulative Rainfall Volume (%)	Flow Rate (L/s)	Flow Rate (L/min)	Surface Loading Rate (L/min/m ²)	Removal Efficiency (%)	Incremental Removal (%)	Cumulative Removal (%)
0.50	8.6	8.6	1.89	113.0	43.0	100	8.6	8.6
1.00	20.3	29.0	3.77	226.0	86.0	98	20.0	28.6
2.00	16.2	45.2	7.54	453.0	172.0	87	14.1	42.7
3.00	12.0	57.2	11.31	679.0	258.0	81	9.7	52.4
4.00	8.4	65.6	15.08	905.0	344.0	77	6.5	58.9
5.00	5.9	71.6	18.86	1131.0	430.0	72	4.3	63.2
6.00	4.6	76.2	22.63	1358.0	516.0	69	3.2	66.4
7.00	3.1	79.3	26.40	1584.0	602.0	65	2.0	68.4
8.00	2.7	82.0	30.17	1810.0	688.0	64	1.8	70.1
9.00	3.3	85.3	33.94	2036.0	774.0	63	2.1	72.2
10.00	2.3	87.6	37.71	2263.0	860.0	63	1.4	73.7
11.00	1.6	89.2	41.48	2489.0	946.0	62	1.0	74.6
12.00	1.3	90.5	45.25	2715.0	1032.0	61	0.8	75.5
13.00	1.7	92.2	49.03	2942.0	1118.0	59	1.0	76.5
14.00	1.2	93.5	52.80	3168.0	1204.0	57	0.7	77.2
15.00	1.2	94.6	56.57	3394.0	1291.0	55	0.6	77.8
16.00	0.7	95.3	60.34	3620.0	1377.0	53	0.4	78.2
17.00	0.7	96.1	64.11	3847.0	1463.0	50	0.4	78.5
18.00	0.4	96.5	67.88	4073.0	1549.0	48	0.2	78.7
19.00	0.4	96.9	71.65	4299.0	1635.0	45	0.2	78.9
20.00	0.2	97.1	75.42	4525.0	1721.0	43	0.1	79.0
21.00	0.5	97.5	79.20	4752.0	1807.0	41	0.2	79.2
22.00	0.2	97.8	82.97	4978.0	1893.0	39	0.1	79.3
23.00	1.0	98.8	86.74	5204.0	1979.0	37	0.4	79.7
24.00	0.3	99.1	90.51	5431.0	2065.0	36	0.1	79.8
25.00	0.0	99.1	94.28	5657.0	2151.0	34	0.0	79.8
30.00	0.9	100.0	113.14	6788.0	2581.0	28	0.3	80.0
35.00	0.0	100.0	131.99	7920.0	3011.0	24	0.0	80.0
40.00	0.0	100.0	150.85	9051.0	3441.0	22	0.0	80.0
45.00	0.0	100.0	169.70	10182.0	3872.0	19	0.0	80.0
Estimated Net Annual Sediment (TSS) Load Reduction =								80 %

Climate Station ID: 6105978 Years of Rainfall Data: 20

Stormceptor® EF Sizing Report

RAINFALL DATA FROM OTTAWA CDA RCS RAINFALL STATION

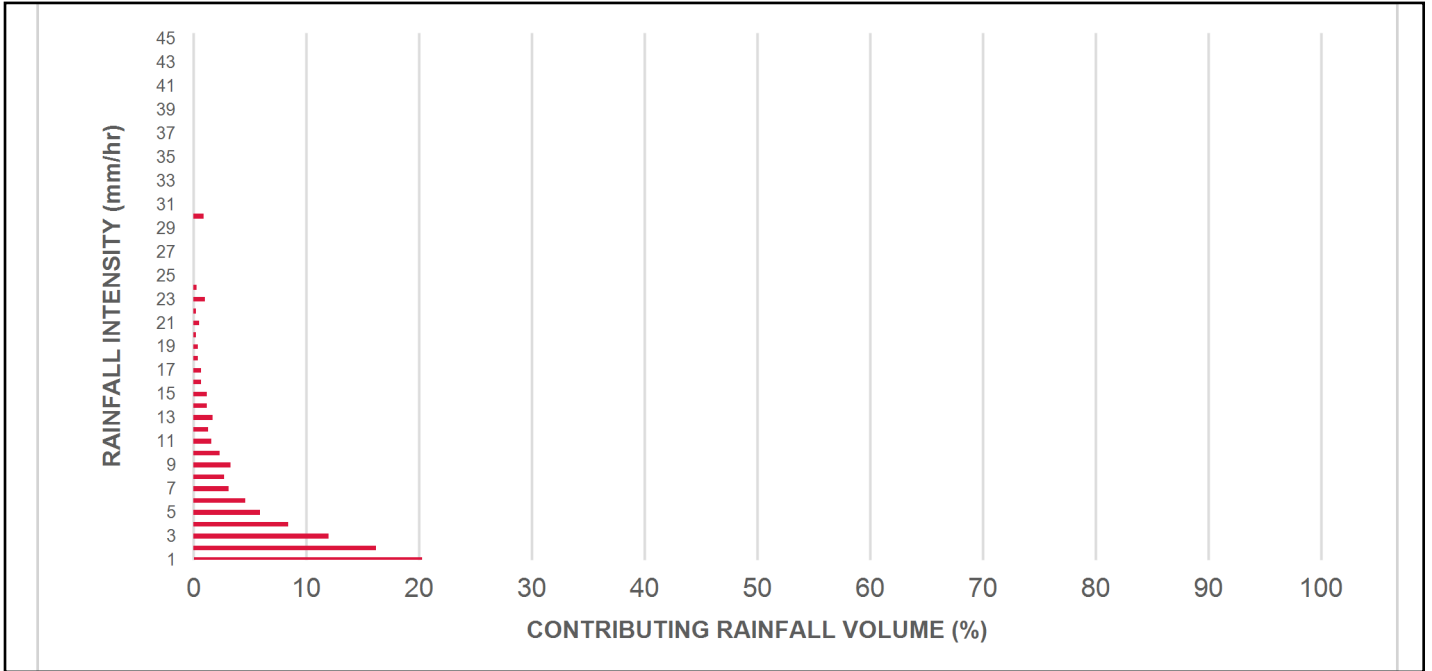

INCREMENTAL AND CUMULATIVE TSS REMOVAL FOR THE RECOMMENDED STORMCEPTOR® MODEL

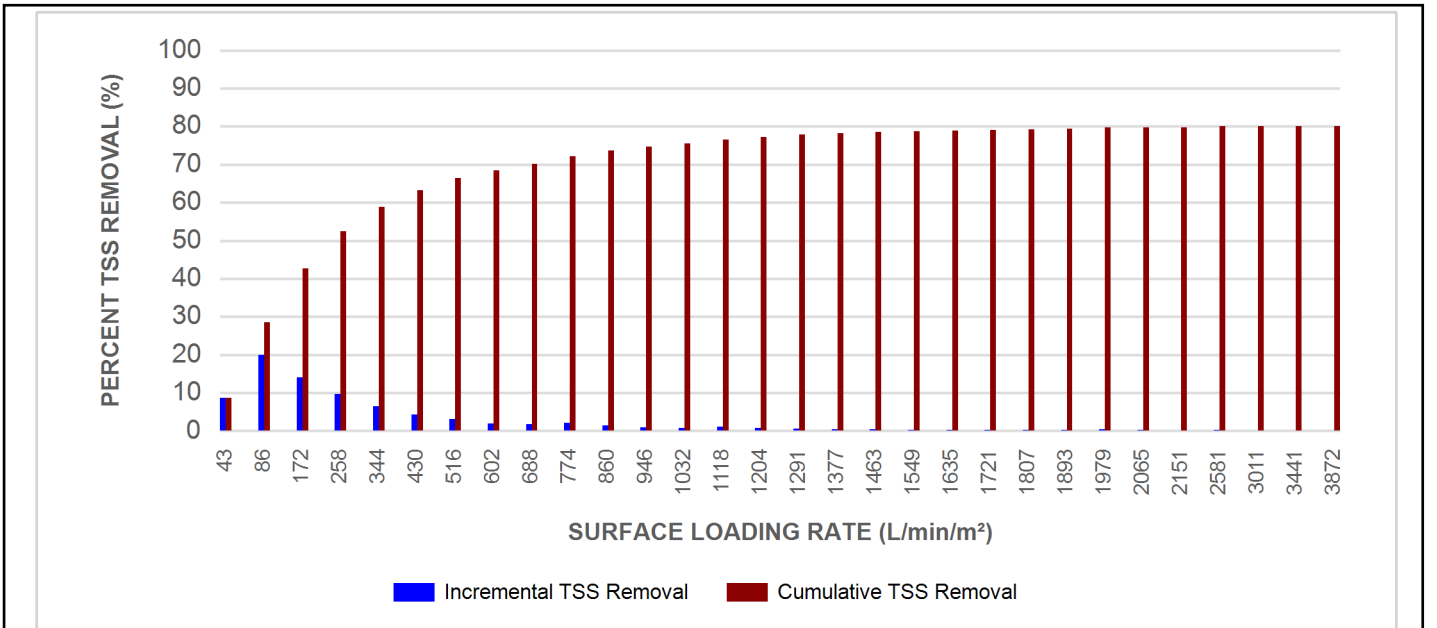

Stormceptor® EF Sizing Report

Maximum Pipe Diameter / Peak Conveyance

Stormceptor EF / EFO	Model Diameter		Min Angle Inlet / Outlet Pipes	Max Inlet Pipe Diameter		Max Outlet Pipe Diameter		Peak Conveyance Flow Rate	
	(m)	(ft)		(mm)	(in)	(mm)	(in)	(L/s)	(cfs)
EF4 / EFO4	1.2	4	90	609	24	609	24	425	15
EF6 / EFO6	1.8	6	90	914	36	914	36	990	35
EF8 / EFO8	2.4	8	90	1219	48	1219	48	1700	60
EF10 / EFO10	3.0	10	90	1828	72	1828	72	2830	100
EF12 / EFO12	3.6	12	90	1828	72	1828	72	2830	100

SCOUR PREVENTION AND ONLINE CONFIGURATION

► Stormceptor® EF and EFO feature an internal bypass and superior scour prevention technology that have been demonstrated in third-party testing according to the scour testing provisions of the Canadian ETV **Procedure for Laboratory Testing of Oil-Grit Separators**, and the exceptional scour test performance has been third-party verified in accordance with the ISO 14034 ETV protocol. As a result, Stormceptor EF and EFO are approved for online installation, eliminating the need for costly additional bypass structures, piping, and installation expense.

DESIGN FLEXIBILITY

► Stormceptor® EF and EFO offers design flexibility in one simplified platform, accepting stormwater flow from a single inlet pipe or multiple inlet pipes, and/or surface runoff through an inlet grate. The device can also serve as a junction structure, accommodate a 90-degree inlet-to-outlet bend angle, and can be modified to ensure performance in submerged conditions.

OIL CAPTURE AND RETENTION

► While Stormceptor® EF will capture and retain oil from dry weather spills and low intensity runoff, Stormceptor® EFO has demonstrated superior oil capture and greater than 99% oil retention in third-party testing according to the light liquid re-entrainment testing provisions of the Canadian ETV **Procedure for Laboratory Testing of Oil-Grit Separators**. Stormceptor EFO is recommended for sites where oil capture and retention is a requirement.

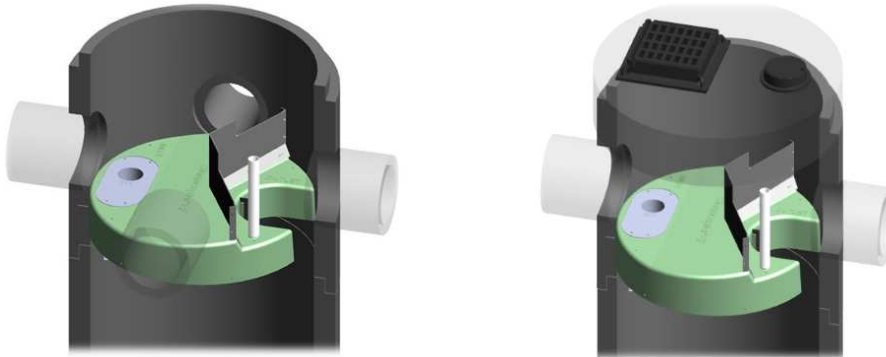

Stormceptor® EF Sizing Report

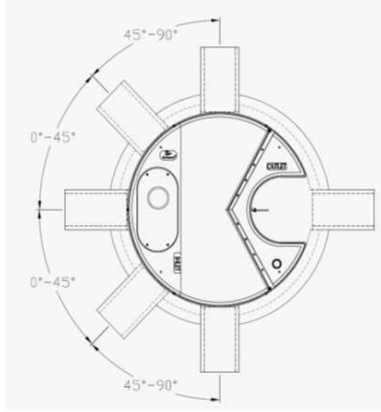

INLET-TO-OUTLET DROP

Elevation differential between inlet and outlet pipe inverts is dictated by the angle at which the inlet pipe(s) enters the unit.

0° - 45° : The inlet pipe is 1-inch (25mm) higher than the outlet pipe.

45° - 90° : The inlet pipe is 2-inches (50mm) higher than the outlet pipe.

HEAD LOSS

The head loss through Stormceptor EF is similar to that of a 60-degree bend structure. The applicable K value for calculating minor losses through the unit is 1.1. For submerged conditions the applicable K value is 3.0.

Pollutant Capacity

Stormceptor EF / EFO	Model Diameter		Depth (Outlet Pipe Invert to Sump Floor)		Oil Volume		Recommended Sediment Maintenance Depth *		Maximum Sediment Volume *		Maximum Sediment Mass **	
	(m)	(ft)	(m)	(ft)	(L)	(Gal)	(mm)	(in)	(L)	(ft³)	(kg)	(lb)
EF4 / EFO4	1.2	4	1.52	5.0	265	70	203	8	1190	42	1904	5250
EF6 / EFO6	1.8	6	1.93	6.3	610	160	305	12	3470	123	5552	15375
EF8 / EFO8	2.4	8	2.59	8.5	1070	280	610	24	8780	310	14048	38750
EF10 / EFO10	3.0	10	3.25	10.7	1670	440	610	24	17790	628	28464	78500
EF12 / EFO12	3.6	12	3.89	12.8	2475	655	610	24	31220	1103	49952	137875

*Increased sump depth may be added to increase sediment storage capacity

** Average density of wet packed sediment in sump = 1.6 kg/L (100 lb/ft³)

Feature	Benefit	Feature Appeals To
Patent-pending enhanced flow treatment and scour prevention technology	Superior, verified third-party performance	Regulator, Specifying & Design Engineer
Third-party verified light liquid capture and retention for EFO version	Proven performance for fuel/oil hotspot locations	Regulator, Specifying & Design Engineer, Site Owner
Functions as bend, junction or inlet structure	Design flexibility	Specifying & Design Engineer
Minimal drop between inlet and outlet	Site installation ease	Contractor
Large diameter outlet riser for inspection and maintenance	Easy maintenance access from grade	Maintenance Contractor & Site Owner

STANDARD STORMCEPTOR EF/EFO DRAWINGS

[For standard details, please visit http://www.imbriumsystems.com/stormwater-treatment-solutions/stormceptor-ef](http://www.imbriumsystems.com/stormwater-treatment-solutions/stormceptor-ef)

STANDARD STORMCEPTOR EF/EFO SPECIFICATION

[For specifications, please visit http://www.imbriumsystems.com/stormwater-treatment-solutions/stormceptor-ef](http://www.imbriumsystems.com/stormwater-treatment-solutions/stormceptor-ef)

STANDARD PERFORMANCE SPECIFICATION FOR “OIL GRIT SEPARATOR” (OGS) STORMWATER QUALITY TREATMENT DEVICE

PART 1 – GENERAL

1.1 WORK INCLUDED

This section specifies requirements for selecting, sizing, and designing an underground Oil Grit Separator (OGS) device for stormwater quality treatment, with third-party testing results and a Statement of Verification in accordance with ISO 14034 Environmental Management – Environmental Technology Verification (ETV).

1.2 REFERENCE STANDARDS & PROCEDURES

ISO 14034:2016 Environmental management – Environmental technology verification (ETV)

Canadian Environmental Technology Verification (ETV) Program’s **Procedure for Laboratory Testing of Oil-Grit Separators**

1.3 SUBMITTALS

1.3.1 All submittals, including sizing reports & shop drawings, shall be submitted upon request with each order to the contractor then forwarded to the Engineer of Record for review and acceptance. Shop drawings shall detail all OGS components, elevations, and sequence of construction.

1.3.2 Alternative devices shall have features identical to or greater than the specified device, including: treatment chamber diameter, treatment chamber wet volume, sediment storage volume, and oil storage volume.

1.3.3 Unless directed otherwise by the Engineer of Record, OGS stormwater quality treatment product substitutions or alternatives submitted within ten days prior to project bid shall not be accepted. All alternatives or substitutions submitted shall be signed and sealed by a local registered Professional Engineer, based on the exact same criteria detailed in Section 3, in entirety, subject to review and approval by the Engineer of Record.

PART 2 – PRODUCTS

2.1 OGS POLLUTANT STORAGE

The OGS device shall include a sump for sediment storage, and a protected volume for the capture and storage of petroleum hydrocarbons and buoyant gross pollutants. The minimum sediment & petroleum hydrocarbon storage capacity shall be as follows:

2.1.1	4 ft (1219 mm) Diameter OGS Units:	1.19 m ³ sediment / 265 L oil
	6 ft (1829 mm) Diameter OGS Units:	3.48 m ³ sediment / 609 L oil
	8 ft (2438 mm) Diameter OGS Units:	8.78 m ³ sediment / 1,071 L oil
	10 ft (3048 mm) Diameter OGS Units:	17.78 m ³ sediment / 1,673 L oil
	12 ft (3657 mm) Diameter OGS Units:	31.23 m ³ sediment / 2,476 L oil

PART 3 – PERFORMANCE & DESIGN

3.1 GENERAL

The OGS stormwater quality treatment device shall be verified in accordance with ISO 14034:2016 Environmental management – Environmental technology verification (ETV). The OGS stormwater quality treatment device shall

Stormceptor® EF Sizing Report

remove oil, sediment and gross pollutants from stormwater runoff during frequent wet weather events, and retain these pollutants during less frequent high flow wet weather events below the insert within the OGS for later removal during maintenance. The Manufacturer shall have at least ten (10) years of local experience, history and success in engineering design, manufacturing and production and supply of OGS stormwater quality treatment device systems, acceptable to the Engineer of Record.

3.2 SIZING METHODOLOGY

The OGS device shall be engineered, designed and sized to provide stormwater quality treatment based on treating a minimum of 90 percent of the average annual runoff volume and a minimum removal of an annual average 60% of the sediment (TSS) load based on the Particle Size Distribution (PSD) specified in the sizing report for the specified device. Sizing of the OGS shall be determined by use of a minimum ten (10) years of local historical rainfall data provided by Environment Canada. Sizing shall also be determined by use of the sediment removal performance data derived from the ISO 14034 ETV third-party verified laboratory testing data from testing conducted in accordance with the Canadian ETV protocol Procedure for Laboratory Testing of Oil-Grit Separators, as follows:

3.2.1 Sediment removal efficiency for a given surface loading rate and its associated flow rate shall be based on sediment removal efficiency demonstrated at the seven (7) tested surface loading rates specified in the protocol, ranging 40 L/min/m² to 1400 L/min/m², and as stated in the ISO 14034 ETV Verification Statement for the OGS device.

3.2.2 Sediment removal efficiency for surface loading rates between 40 L/min/m² and 1400 L/min/m² shall be based on linear interpolation of data between consecutive tested surface loading rates.

3.2.3 Sediment removal efficiency for surface loading rates less than the lowest tested surface loading rate of 40 L/min/m² shall be assumed to be identical to the sediment removal efficiency at 40 L/min/m². No extrapolation shall be allowed that results in a sediment removal efficiency that is greater than that demonstrated at 40 L/min/m².

3.2.4 Sediment removal efficiency for surface loading rates greater than the highest tested surface loading rate of 1400 L/min/m² shall assume zero sediment removal for the portion of flow that exceeds 1400 L/min/m², and shall be calculated using a simple proportioning formula, with 1400 L/min/m² in the numerator and the higher surface loading rate in the denominator, and multiplying the resulting fraction times the sediment removal efficiency at 1400 L/min/m².

The OGS device shall also have sufficient annual sediment storage capacity as specified and calculated in Section 2.1.

3.3 CANADIAN ETV or ISO 14034 ETV VERIFICATION OF SCOUR TESTING

The OGS device shall have Canadian ETV or ISO 14034 ETV Verification of third-party scour testing conducted in accordance with the Canadian ETV Program's **Procedure for Laboratory Testing of Oil-Grit Separators**.

3.3.1 To be acceptable for on-line installation, the OGS device must demonstrate an average scour test effluent concentration less than 10 mg/L at each surface loading rate tested, up to and including 2600 L/min/m².

3.4 LIGHT LIQUID RE-ENTRAINMENT SIMULATION TESTING

The OGS device shall have Canadian ETV or ISO 14034 ETV Verification of completed third-party Light Liquid Re-entrainment Simulation Testing in accordance with the Canadian ETV **Program's Procedure for Laboratory Testing of Oil-Grit Separators**, with results reported within the Canadian ETV or ISO 14034 ETV verification. This re-entrainment testing is conducted with the device pre-loaded with low density polyethylene (LDPE) plastic beads as a surrogate for light liquids such as oil and fuel. Testing is conducted on the same OGS unit tested for sediment removal to

Stormceptor® EF Sizing Report

assess whether light liquids captured after a spill are effectively retained at high flow rates.

3.4.1 For an OGS device to be an acceptable stormwater treatment device on a site where vehicular traffic occurs and the potential for an oil or fuel spill exists, the OGS device must have reported verified performance results of greater than 99% cumulative retention of LDPE plastic beads for the five specified surface loading rates (ranging 200 L/min/m² to 2600 L/min/m²) in accordance with the Light Liquid Re-entrainment Simulation Testing within the Canadian ETV Program's **Procedure for Laboratory Testing of Oil-Grit Separators**. However, an OGS device shall not be allowed if the Light Liquid Re-entrainment Simulation Testing was performed with screening components within the OGS device that are effective at retaining the LDPE plastic beads, but would not be expected to retain light liquids such as oil and fuel.

Stormceptor® EF Sizing Report

Imbrium® Systems

ESTIMATED NET ANNUAL SEDIMENT (TSS) LOAD REDUCTION

03/20/2024

Province:	Ontario
City:	Ottawa
Nearest Rainfall Station:	OTTAWA CDA RCS
Climate Station Id:	6105978
Years of Rainfall Data:	20

Project Name:	1500 Merivale (N)
Project Number:	64165
Designer Name:	Kallie Auld
Designer Company:	Novatech
Designer Email:	k.auld@novatech-eng.com
Designer Phone:	613-254-9643
EOR Name:	
EOR Company:	
EOR Email:	
EOR Phone:	

Site Name:	1500 Merivale (S)
------------	-------------------

Drainage Area (ha):	2.8
---------------------	-----

% Imperviousness:	75.00
-------------------	-------

Runoff Coefficient 'c': 0.75

Particle Size Distribution:	Fine
-----------------------------	------

Target TSS Removal (%):	80.0
-------------------------	------

Required Water Quality Runoff Volume Capture (%):	90.00
Estimated Water Quality Flow Rate (L/s):	67.78
Oil / Fuel Spill Risk Site?	Yes
Upstream Flow Control?	No
Peak Conveyance (maximum) Flow Rate (L/s):	130.00
Influent TSS Concentration (mg/L):	200
Estimated Average Annual Sediment Load (kg/yr):	2343
Estimated Average Annual Sediment Volume (L/yr):	1905

Net Annual Sediment (TSS) Load Reduction Sizing Summary	
Stormceptor Model	TSS Removal Provided (%)
EFO4	57
EFO6	73
EFO8	82
EFO10	88
EFO12	91

Recommended Stormceptor EFO Model: EFO8

Estimated Net Annual Sediment (TSS) Load Reduction (%): 82

Water Quality Runoff Volume Capture (%): > 90

THIRD-PARTY TESTING AND VERIFICATION

► **Stormceptor® EF and Stormceptor® EFO** are the latest evolutions in the Stormceptor® oil-grit separator (OGS) technology series, and are designed to remove a wide variety of pollutants from stormwater and snowmelt runoff. These technologies have been third-party tested in accordance with the Canadian ETV **Procedure for Laboratory Testing of Oil-Grit Separators** and performance has been third-party verified in accordance with the **ISO 14034 Environmental Technology Verification (ETV)** protocol.

PERFORMANCE

► **Stormceptor® EF and EFO** remove stormwater pollutants through gravity separation and floatation, and feature a patent-pending design that generates positive removal of total suspended solids (TSS) throughout each storm event, including high-intensity storms. Captured pollutants include sediment, free oils, and sediment-bound pollutants such as nutrients, heavy metals, and petroleum hydrocarbons. Stormceptor is sized to remove a high level of TSS from the frequent rainfall events that contribute the vast majority of annual runoff volume and pollutant load. The technology incorporates an internal bypass to convey excessive stormwater flows from high-intensity storms through the device without resuspension and washout (scour) of previously captured pollutants. Proper routine maintenance ensures high pollutant removal performance and protection of downstream waterways.

PARTICLE SIZE DISTRIBUTION (PSD)

► The **Canadian ETV PSD** shown in the table below was used, or in part, for this sizing. This is the identical PSD that is referenced in the Canadian ETV **Procedure for Laboratory Testing of Oil-Grit Separators** for both sediment removal testing and scour testing. The Canadian ETV PSD contains a wide range of particle sizes in the sand and silt fractions, and is considered reasonably representative of the particle size fractions found in typical urban stormwater runoff.

Particle Size (µm)	Percent Less Than	Particle Size Fraction (µm)	Percent
1000	100	500-1000	5
500	95	250-500	5
250	90	150-250	15
150	75	100-150	15
100	60	75-100	10
75	50	50-75	5
50	45	20-50	10
20	35	8-20	15
8	20	5-8	10
5	10	2-5	5
2	5	<2	5

Stormceptor® EF Sizing Report

Rainfall Intensity (mm / hr)	Percent Rainfall Volume (%)	Cumulative Rainfall Volume (%)	Flow Rate (L/s)	Flow Rate (L/min)	Surface Loading Rate (L/min/m ²)	Removal Efficiency (%)	Incremental Removal (%)	Cumulative Removal (%)
0.50	8.6	8.6	2.92	175.0	37.0	100	8.6	8.6
1.00	20.3	29.0	5.84	350.0	75.0	100	20.3	29.0
2.00	16.2	45.2	11.68	701.0	149.0	89	14.5	43.5
3.00	12.0	57.2	17.51	1051.0	224.0	82	9.9	53.3
4.00	8.4	65.6	23.35	1401.0	298.0	79	6.7	60.0
5.00	5.9	71.6	29.19	1751.0	373.0	75	4.5	64.5
6.00	4.6	76.2	35.03	2102.0	447.0	72	3.3	67.8
7.00	3.1	79.3	40.87	2452.0	522.0	68	2.1	69.9
8.00	2.7	82.0	46.70	2802.0	596.0	65	1.8	71.7
9.00	3.3	85.3	52.54	3153.0	671.0	64	2.1	73.8
10.00	2.3	87.6	58.38	3503.0	745.0	64	1.5	75.3
11.00	1.6	89.2	64.22	3853.0	820.0	63	1.0	76.3
12.00	1.3	90.5	70.06	4203.0	894.0	62	0.8	77.1
13.00	1.7	92.2	75.89	4554.0	969.0	62	1.1	78.1
14.00	1.2	93.5	81.73	4904.0	1043.0	61	0.7	78.9
15.00	1.2	94.6	87.57	5254.0	1118.0	59	0.7	79.6
16.00	0.7	95.3	93.41	5604.0	1192.0	57	0.4	80.0
17.00	0.7	96.1	99.25	5955.0	1267.0	56	0.4	80.4
18.00	0.4	96.5	105.08	6305.0	1341.0	54	0.2	80.6
19.00	0.4	96.9	110.92	6655.0	1416.0	52	0.2	80.8
20.00	0.2	97.1	116.76	7006.0	1491.0	49	0.1	80.9
21.00	0.5	97.5	122.60	7356.0	1565.0	47	0.2	81.1
22.00	0.2	97.8	128.44	7706.0	1640.0	45	0.1	81.2
23.00	1.0	98.8	134.27	8056.0	1714.0	43	0.4	81.7
24.00	0.3	99.1	140.11	8407.0	1789.0	41	0.1	81.8
25.00	0.0	99.1	145.95	8757.0	1863.0	39	0.0	81.8
30.00	0.9	100.0	175.14	10508.0	2236.0	33	0.3	82.1
35.00	0.0	100.0	204.33	12260.0	2608.0	28	0.0	82.1
40.00	0.0	100.0	233.52	14011.0	2981.0	25	0.0	82.1
45.00	0.0	100.0	262.71	15763.0	3354.0	22	0.0	82.1
Estimated Net Annual Sediment (TSS) Load Reduction =								82 %

Climate Station ID: 6105978 Years of Rainfall Data: 20

Stormceptor® EF Sizing Report

RAINFALL DATA FROM OTTAWA CDA RCS RAINFALL STATION

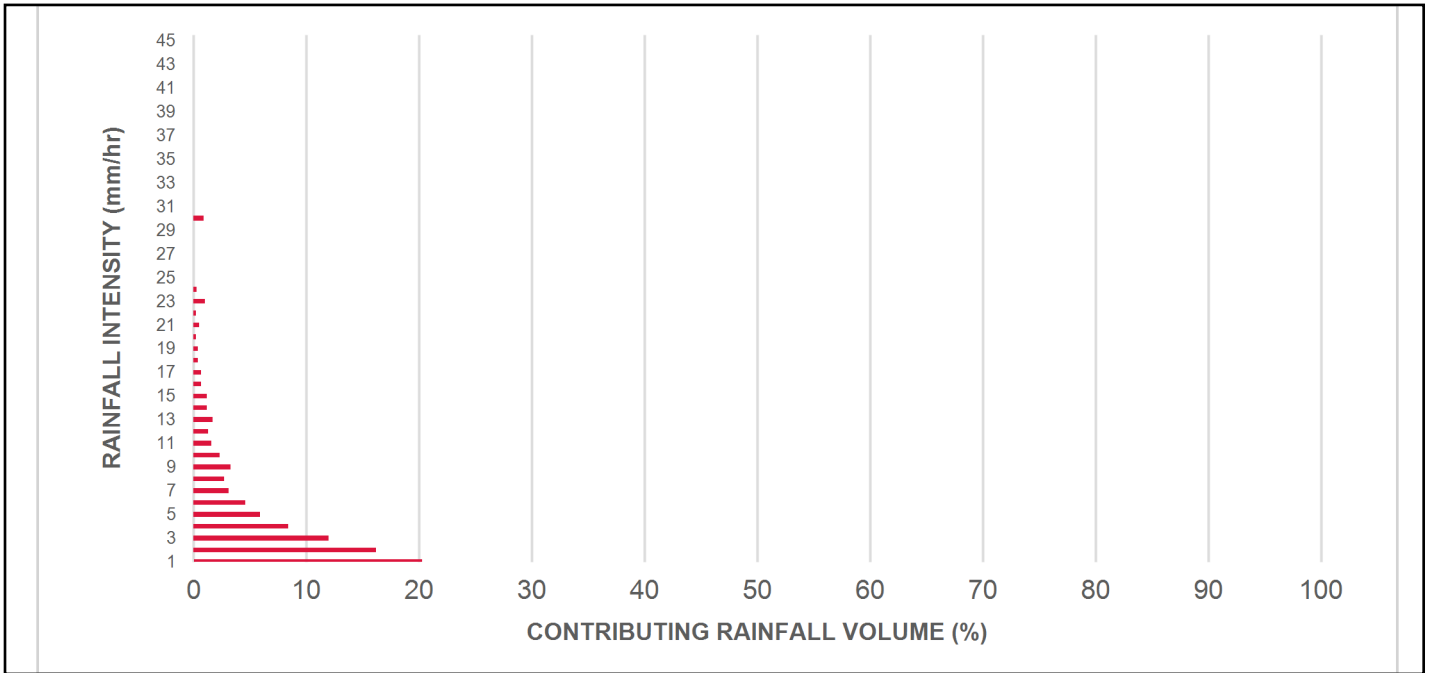

INCREMENTAL AND CUMULATIVE TSS REMOVAL FOR THE RECOMMENDED STORMCEPTOR® MODEL

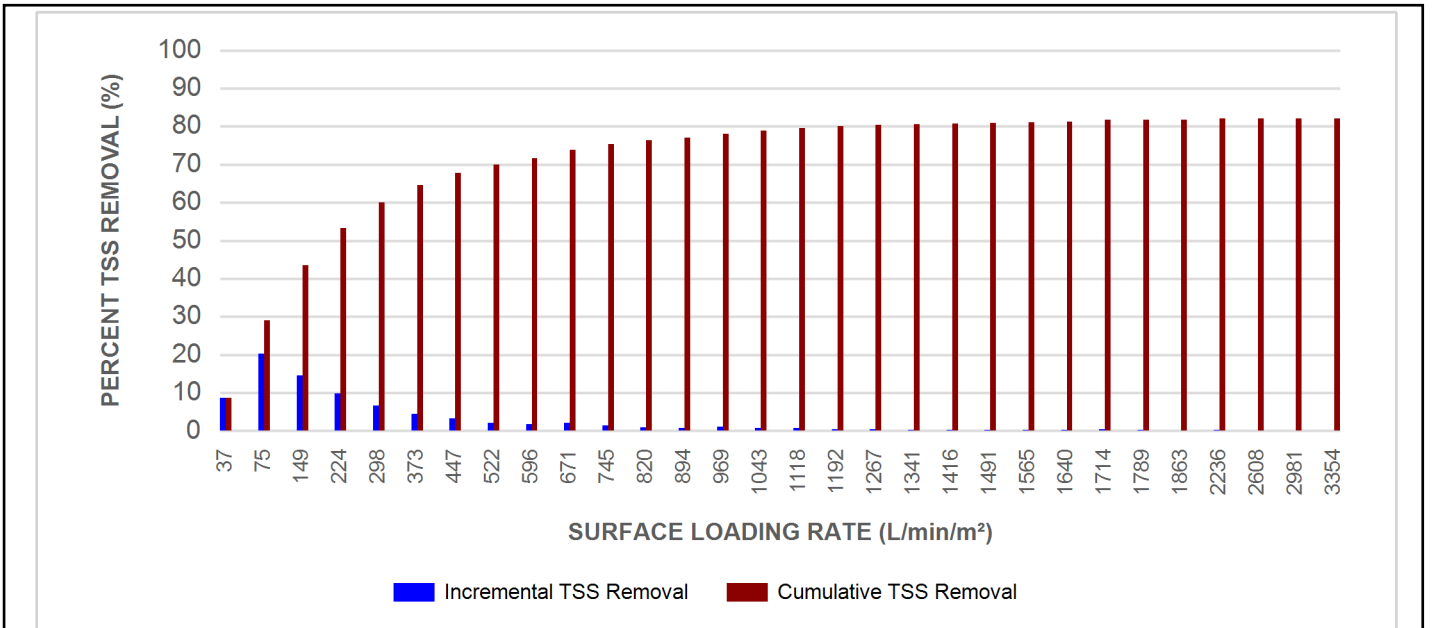

Stormceptor® EF Sizing Report

Maximum Pipe Diameter / Peak Conveyance

Stormceptor EF / EFO	Model Diameter		Min Angle Inlet / Outlet Pipes	Max Inlet Pipe Diameter		Max Outlet Pipe Diameter		Peak Conveyance Flow Rate	
	(m)	(ft)		(mm)	(in)	(mm)	(in)	(L/s)	(cfs)
EF4 / EFO4	1.2	4	90	609	24	609	24	425	15
EF6 / EFO6	1.8	6	90	914	36	914	36	990	35
EF8 / EFO8	2.4	8	90	1219	48	1219	48	1700	60
EF10 / EFO10	3.0	10	90	1828	72	1828	72	2830	100
EF12 / EFO12	3.6	12	90	1828	72	1828	72	2830	100

SCOUR PREVENTION AND ONLINE CONFIGURATION

► Stormceptor® EF and EFO feature an internal bypass and superior scour prevention technology that have been demonstrated in third-party testing according to the scour testing provisions of the Canadian ETV **Procedure for Laboratory Testing of Oil-Grit Separators**, and the exceptional scour test performance has been third-party verified in accordance with the ISO 14034 ETV protocol. As a result, Stormceptor EF and EFO are approved for online installation, eliminating the need for costly additional bypass structures, piping, and installation expense.

DESIGN FLEXIBILITY

► Stormceptor® EF and EFO offers design flexibility in one simplified platform, accepting stormwater flow from a single inlet pipe or multiple inlet pipes, and/or surface runoff through an inlet grate. The device can also serve as a junction structure, accommodate a 90-degree inlet-to-outlet bend angle, and can be modified to ensure performance in submerged conditions.

OIL CAPTURE AND RETENTION

► While Stormceptor® EF will capture and retain oil from dry weather spills and low intensity runoff, Stormceptor® EFO has demonstrated superior oil capture and greater than 99% oil retention in third-party testing according to the light liquid re-entrainment testing provisions of the Canadian ETV **Procedure for Laboratory Testing of Oil-Grit Separators**. Stormceptor EFO is recommended for sites where oil capture and retention is a requirement.

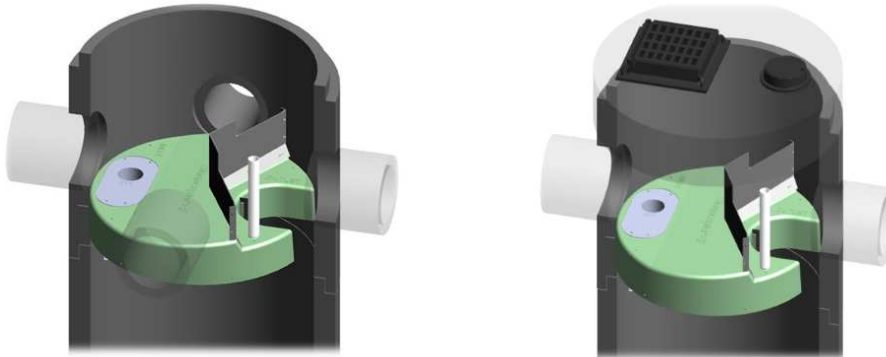

Stormceptor® EF Sizing Report

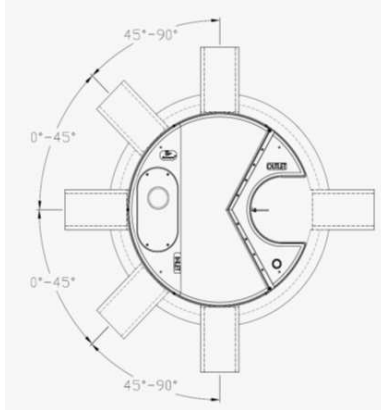

INLET-TO-OUTLET DROP

Elevation differential between inlet and outlet pipe inverts is dictated by the angle at which the inlet pipe(s) enters the unit.

0° - 45° : The inlet pipe is 1-inch (25mm) higher than the outlet pipe.

45° - 90° : The inlet pipe is 2-inches (50mm) higher than the outlet pipe.

HEAD LOSS

The head loss through Stormceptor EF is similar to that of a 60-degree bend structure. The applicable K value for calculating minor losses through the unit is 1.1. For submerged conditions the applicable K value is 3.0.

Pollutant Capacity

Stormceptor EF / EFO	Model Diameter		Depth (Outlet Pipe Invert to Sump Floor)		Oil Volume		Recommended Sediment Maintenance Depth *		Maximum Sediment Volume *		Maximum Sediment Mass **	
	(m)	(ft)	(m)	(ft)	(L)	(Gal)	(mm)	(in)	(L)	(ft³)	(kg)	(lb)
EF4 / EFO4	1.2	4	1.52	5.0	265	70	203	8	1190	42	1904	5250
EF6 / EFO6	1.8	6	1.93	6.3	610	160	305	12	3470	123	5552	15375
EF8 / EFO8	2.4	8	2.59	8.5	1070	280	610	24	8780	310	14048	38750
EF10 / EFO10	3.0	10	3.25	10.7	1670	440	610	24	17790	628	28464	78500
EF12 / EFO12	3.6	12	3.89	12.8	2475	655	610	24	31220	1103	49952	137875

*Increased sump depth may be added to increase sediment storage capacity

** Average density of wet packed sediment in sump = 1.6 kg/L (100 lb/ft³)

Feature	Benefit	Feature Appeals To
Patent-pending enhanced flow treatment and scour prevention technology	Superior, verified third-party performance	Regulator, Specifying & Design Engineer
Third-party verified light liquid capture and retention for EFO version	Proven performance for fuel/oil hotspot locations	Regulator, Specifying & Design Engineer, Site Owner
Functions as bend, junction or inlet structure	Design flexibility	Specifying & Design Engineer
Minimal drop between inlet and outlet	Site installation ease	Contractor
Large diameter outlet riser for inspection and maintenance	Easy maintenance access from grade	Maintenance Contractor & Site Owner

STANDARD STORMCEPTOR EF/EFO DRAWINGS

[For standard details, please visit http://www.imbriumsystems.com/stormwater-treatment-solutions/stormceptor-ef](http://www.imbriumsystems.com/stormwater-treatment-solutions/stormceptor-ef)

STANDARD STORMCEPTOR EF/EFO SPECIFICATION

[For specifications, please visit http://www.imbriumsystems.com/stormwater-treatment-solutions/stormceptor-ef](http://www.imbriumsystems.com/stormwater-treatment-solutions/stormceptor-ef)

STANDARD PERFORMANCE SPECIFICATION FOR “OIL GRIT SEPARATOR” (OGS) STORMWATER QUALITY TREATMENT DEVICE

PART 1 – GENERAL

1.1 WORK INCLUDED

This section specifies requirements for selecting, sizing, and designing an underground Oil Grit Separator (OGS) device for stormwater quality treatment, with third-party testing results and a Statement of Verification in accordance with ISO 14034 Environmental Management – Environmental Technology Verification (ETV).

1.2 REFERENCE STANDARDS & PROCEDURES

ISO 14034:2016 Environmental management – Environmental technology verification (ETV)

Canadian Environmental Technology Verification (ETV) Program’s **Procedure for Laboratory Testing of Oil-Grit Separators**

1.3 SUBMITTALS

1.3.1 All submittals, including sizing reports & shop drawings, shall be submitted upon request with each order to the contractor then forwarded to the Engineer of Record for review and acceptance. Shop drawings shall detail all OGS components, elevations, and sequence of construction.

1.3.2 Alternative devices shall have features identical to or greater than the specified device, including: treatment chamber diameter, treatment chamber wet volume, sediment storage volume, and oil storage volume.

1.3.3 Unless directed otherwise by the Engineer of Record, OGS stormwater quality treatment product substitutions or alternatives submitted within ten days prior to project bid shall not be accepted. All alternatives or substitutions submitted shall be signed and sealed by a local registered Professional Engineer, based on the exact same criteria detailed in Section 3, in entirety, subject to review and approval by the Engineer of Record.

PART 2 – PRODUCTS

2.1 OGS POLLUTANT STORAGE

The OGS device shall include a sump for sediment storage, and a protected volume for the capture and storage of petroleum hydrocarbons and buoyant gross pollutants. The minimum sediment & petroleum hydrocarbon storage capacity shall be as follows:

2.1.1	4 ft (1219 mm) Diameter OGS Units:	1.19 m ³ sediment / 265 L oil
	6 ft (1829 mm) Diameter OGS Units:	3.48 m ³ sediment / 609 L oil
	8 ft (2438 mm) Diameter OGS Units:	8.78 m ³ sediment / 1,071 L oil
	10 ft (3048 mm) Diameter OGS Units:	17.78 m ³ sediment / 1,673 L oil
	12 ft (3657 mm) Diameter OGS Units:	31.23 m ³ sediment / 2,476 L oil

PART 3 – PERFORMANCE & DESIGN

3.1 GENERAL

The OGS stormwater quality treatment device shall be verified in accordance with ISO 14034:2016 Environmental management – Environmental technology verification (ETV). The OGS stormwater quality treatment device shall

Stormceptor[®] EF Sizing Report

remove oil, sediment and gross pollutants from stormwater runoff during frequent wet weather events, and retain these pollutants during less frequent high flow wet weather events below the insert within the OGS for later removal during maintenance. The Manufacturer shall have at least ten (10) years of local experience, history and success in engineering design, manufacturing and production and supply of OGS stormwater quality treatment device systems, acceptable to the Engineer of Record.

3.2 SIZING METHODOLOGY

The OGS device shall be engineered, designed and sized to provide stormwater quality treatment based on treating a minimum of 90 percent of the average annual runoff volume and a minimum removal of an annual average 60% of the sediment (TSS) load based on the Particle Size Distribution (PSD) specified in the sizing report for the specified device. Sizing of the OGS shall be determined by use of a minimum ten (10) years of local historical rainfall data provided by Environment Canada. Sizing shall also be determined by use of the sediment removal performance data derived from the ISO 14034 ETV third-party verified laboratory testing data from testing conducted in accordance with the Canadian ETV protocol Procedure for Laboratory Testing of Oil-Grit Separators, as follows:

3.2.1 Sediment removal efficiency for a given surface loading rate and its associated flow rate shall be based on sediment removal efficiency demonstrated at the seven (7) tested surface loading rates specified in the protocol, ranging 40 L/min/m² to 1400 L/min/m², and as stated in the ISO 14034 ETV Verification Statement for the OGS device.

3.2.2 Sediment removal efficiency for surface loading rates between 40 L/min/m² and 1400 L/min/m² shall be based on linear interpolation of data between consecutive tested surface loading rates.

3.2.3 Sediment removal efficiency for surface loading rates less than the lowest tested surface loading rate of 40 L/min/m² shall be assumed to be identical to the sediment removal efficiency at 40 L/min/m². No extrapolation shall be allowed that results in a sediment removal efficiency that is greater than that demonstrated at 40 L/min/m².

3.2.4 Sediment removal efficiency for surface loading rates greater than the highest tested surface loading rate of 1400 L/min/m² shall assume zero sediment removal for the portion of flow that exceeds 1400 L/min/m², and shall be calculated using a simple proportioning formula, with 1400 L/min/m² in the numerator and the higher surface loading rate in the denominator, and multiplying the resulting fraction times the sediment removal efficiency at 1400 L/min/m².

The OGS device shall also have sufficient annual sediment storage capacity as specified and calculated in Section 2.1.

3.3 CANADIAN ETV or ISO 14034 ETV VERIFICATION OF SCOUR TESTING

The OGS device shall have Canadian ETV or ISO 14034 ETV Verification of third-party scour testing conducted in accordance with the Canadian ETV Program's **Procedure for Laboratory Testing of Oil-Grit Separators**.

3.3.1 To be acceptable for on-line installation, the OGS device must demonstrate an average scour test effluent concentration less than 10 mg/L at each surface loading rate tested, up to and including 2600 L/min/m².

3.4 LIGHT LIQUID RE-ENTRAINMENT SIMULATION TESTING

The OGS device shall have Canadian ETV or ISO 14034 ETV Verification of completed third-party Light Liquid Re-entrainment Simulation Testing in accordance with the Canadian ETV **Program's Procedure for Laboratory Testing of Oil-Grit Separators**, with results reported within the Canadian ETV or ISO 14034 ETV verification. This re-entrainment testing is conducted with the device pre-loaded with low density polyethylene (LDPE) plastic beads as a surrogate for light liquids such as oil and fuel. Testing is conducted on the same OGS unit tested for sediment removal to

Stormceptor[®] EF Sizing Report

assess whether light liquids captured after a spill are effectively retained at high flow rates.

3.4.1 For an OGS device to be an acceptable stormwater treatment device on a site where vehicular traffic occurs and the potential for an oil or fuel spill exists, the OGS device must have reported verified performance results of greater than 99% cumulative retention of LDPE plastic beads for the five specified surface loading rates (ranging 200 L/min/m² to 2600 L/min/m²) in accordance with the Light Liquid Re-entrainment Simulation Testing within the Canadian ETV Program's **Procedure for Laboratory Testing of Oil-Grit Separators**. However, an OGS device shall not be allowed if the Light Liquid Re-entrainment Simulation Testing was performed with screening components within the OGS device that are effective at retaining the LDPE plastic beads, but would not be expected to retain light liquids such as oil and fuel.

EPA STORM WATER MANAGEMENT MODEL - VERSION 5.2 (Build 5.2.4)

1500 Merivale - Detailed design of Phase 1

WARNING 04: minimum elevation drop used for Conduit 302-301
 WARNING 03: negative offset ignored for Link C15
 WARNING 03: negative offset ignored for Link C16
 WARNING 04: minimum elevation drop used for Conduit C16
 WARNING 04: minimum elevation drop used for Conduit C20
 WARNING 04: minimum elevation drop used for Conduit C26
 WARNING 04: minimum elevation drop used for Conduit C32
 WARNING 02: maximum depth increased for Node CB001
 WARNING 02: maximum depth increased for Node CB002
 WARNING 02: maximum depth increased for Node CB013
 WARNING 02: maximum depth increased for Node CB014
 WARNING 02: maximum depth increased for Node CB017
 WARNING 02: maximum depth increased for Node CB018
 WARNING 02: maximum depth increased for Node CB112
 WARNING 02: maximum depth increased for Node J13
 WARNING 02: maximum depth increased for Node PH01-STOR

 Element Count

Number of rain gages 1
 Number of subcatchments ... 37
 Number of nodes 81
 Number of links 102
 Number of pollutants 0
 Number of land uses 0

 Raingage Summary

Name	Data Source	Data Type	Recording Interval
Raingage1	03-C100yr-3hr	INTENSITY	10 min.

 Subcatchment Summary

Name Outlet	Area	Width	%Imperv	%Slope	Rain Gage
A01a	0.08	61.04	83.00	2.5000	Raingage1
CB001					
A01b	0.11	64.98	50.00	2.5000	Raingage1
CB002					
A02a	0.04	48.57	74.00	2.5000	Raingage1
CB003					
A02b	0.07	47.57	77.00	2.5000	Raingage1
CB004					
A03a	0.03	36.23	87.00	2.5000	Raingage1

A03b	0.05	32.93	79.00	2.5000	Raingage1
CB006					
A04a	0.08	40.55	94.00	2.5000	Raingage1
CB007					
A04b	0.07	35.72	77.00	2.5000	Raingage1
CB008					
A05a	0.08	42.73	100.00	2.5000	Raingage1
CB009					
A05b	0.07	47.59	79.00	2.5000	Raingage1
CB010					
A06a	0.04	29.34	100.00	2.5000	Raingage1
CB011					
A06b	0.04	27.25	77.00	2.5000	Raingage1
CB012					
B01a	0.10	66.69	89.00	2.5000	Raingage1
CB013					
B01b	0.05	51.36	86.00	2.5000	Raingage1
CB014					
B02a	0.03	27.70	91.00	2.5000	Raingage1
CB015					
B02b	0.02	20.79	100.00	2.5000	Raingage1
CB016					
B03a	0.14	84.00	93.00	2.5000	Raingage1
CB017					
B03b	0.05	103.88	66.00	2.5000	Raingage1
CB018					
B04a	0.01	23.94	100.00	2.5000	Raingage1
CB019					
B04b	0.01	21.81	64.00	2.5000	Raingage1
CB020					
B-05	0.13	58.40	94.00	2.5000	Raingage1
CB021					
BLDG01	0.15	49.46	100.00	0.5000	Raingage1
PH01-STOR					
P01-1	0.11	39.92	44.00	0.5000	Raingage1
PH01-STOR					
P01-2	0.03	30.33	59.00	0.5000	Raingage1
PH01-STOR					
PH02	0.41	118.94	60.00	0.5000	Raingage1
PH02-STOR					
PH03	0.14	34.33	10.00	0.5000	Raingage1
PH03-STOR					
PH04	0.24	27.99	100.00	0.5000	Raingage1
PH04-STOR					
PH05	0.62	84.28	81.00	0.5000	Raingage1
PH05-STOR					
PH06	0.47	86.04	72.00	0.5000	Raingage1
PH06-STOR					
PH07	0.31	72.80	69.00	0.5000	Raingage1
PH07-STOR					
PH08	0.33	98.62	67.00	0.5000	Raingage1
PH08-STOR					
PH09	0.60	63.26	77.00	0.5000	Raingage1
PH09-STOR					
PH10	0.63	66.36	67.00	0.5000	Raingage1
PH10-STOR					
PH11	0.20	58.44	76.00	0.5000	Raingage1
PH11-STOR					
xD-02	0.00	14.18	100.00	0.5000	Raingage1
DR-M					

```

xD-04      0.01  32.23   0.00   0.5000 Raingagel
DR-M
xPARK01    0.52  94.22   29.00   1.7000 Raingagel
J6
    
```

Node Summary

Name	Type	Invert Elev.	Max. Depth	Ponded Area	External Inflow
495_(STM)	JUNCTION	99.36	1.79	0.0	
502_(STM)	JUNCTION	97.72	1.83	0.0	
503_(STM)	JUNCTION	98.99	2.33	0.0	
573_(STM)	JUNCTION	98.75	1.74	0.0	
CB001	JUNCTION	92.67	1.76	0.0	
CB002	JUNCTION	92.77	1.66	0.0	
CB003	JUNCTION	94.88	0.35	0.0	
CB004	JUNCTION	94.88	0.35	0.0	
CB005	JUNCTION	96.30	0.35	0.0	
CB006	JUNCTION	96.30	0.35	0.0	
CB007	JUNCTION	97.67	0.35	0.0	
CB008	JUNCTION	97.67	0.35	0.0	
CB009	JUNCTION	99.76	0.35	0.0	
CB010	JUNCTION	99.76	0.35	0.0	
CB011	JUNCTION	101.37	0.35	0.0	
CB012	JUNCTION	101.37	0.35	0.0	
CB013	JUNCTION	93.24	1.65	0.0	
CB014	JUNCTION	93.24	1.65	0.0	
CB015	JUNCTION	95.42	0.35	0.0	
CB016	JUNCTION	95.42	0.35	0.0	
CB017	JUNCTION	93.90	2.25	0.0	
CB018	JUNCTION	93.90	2.25	0.0	
CB019	JUNCTION	96.80	0.35	0.0	
CB020	JUNCTION	96.80	0.35	0.0	
CB021	JUNCTION	95.35	1.60	0.0	
CB110	JUNCTION	92.89	2.01	0.0	
CB112	JUNCTION	93.32	1.55	0.0	
J1	JUNCTION	94.55	0.35	0.0	
J10	JUNCTION	94.46	0.35	0.0	
J11	JUNCTION	94.91	0.35	0.0	
J12	JUNCTION	96.37	0.35	0.0	
J13	JUNCTION	96.95	0.35	0.0	
J2	JUNCTION	95.84	0.35	0.0	
J3	JUNCTION	95.84	0.35	0.0	
J6	JUNCTION	95.79	0.30	0.0	
J7	JUNCTION	97.16	0.35	0.0	
J8	JUNCTION	97.16	0.35	0.0	
J9	JUNCTION	98.31	0.35	0.0	
300_(STM)	OUTFALL	92.12	1.20	0.0	
DR-M	OUTFALL	0.00	0.00	0.0	
J4	OUTFALL	101.95	0.35	0.0	
J5	OUTFALL	101.95	0.35	0.0	
MHST27978	OUTFALL	97.28	0.60	0.0	
MHST27980	OUTFALL	97.90	0.33	0.0	
MHST47195	OUTFALL	91.50	1.36	0.0	

OF1	OUTFALL	94.07	0.35	0.0
OF2	OUTFALL	94.07	0.35	0.0
OF3	OUTFALL	94.55	0.35	0.0
OF4	OUTFALL	94.55	0.35	0.0
MH101	STORAGE	92.23	1.83	0.0
MH102	STORAGE	92.27	1.81	0.0
MH103	STORAGE	92.42	1.64	0.0
MH104	STORAGE	92.58	2.10	0.0
MH105	STORAGE	93.88	2.68	0.0
MH106	STORAGE	94.35	2.82	0.0
MH107	STORAGE	94.88	3.09	0.0
MH108	STORAGE	95.89	2.70	0.0
MH109	STORAGE	98.63	2.93	0.0
MH301	STORAGE	92.62	1.94	0.0
MH302	STORAGE	92.70	1.85	0.0
MH303	STORAGE	92.75	1.74	0.0
MH304	STORAGE	92.80	1.72	0.0
MH305	STORAGE	92.89	1.69	0.0
MH306	STORAGE	93.01	2.05	0.0
MH307	STORAGE	93.07	2.63	0.0
MH308	STORAGE	93.33	2.54	0.0
MH309	STORAGE	93.74	2.53	0.0
MH310	STORAGE	94.02	2.48	0.0
MH311	STORAGE	94.89	2.30	0.0
PH01-STOR	STORAGE	93.00	3.00	0.0
PH02-STOR	STORAGE	93.00	2.00	0.0
PH03-STOR	STORAGE	94.40	2.00	0.0
PH04-STOR	STORAGE	99.50	2.00	0.0
PH05-STOR	STORAGE	99.00	2.00	0.0
PH06-STOR	STORAGE	97.80	2.00	0.0
PH07-STOR	STORAGE	94.30	2.00	0.0
PH08-STOR	STORAGE	93.70	2.00	0.0
PH09-STOR	STORAGE	93.50	2.00	0.0
PH10-STOR	STORAGE	93.50	2.00	0.0
PH11-STOR	STORAGE	93.50	2.00	0.0
SU1	STORAGE	93.00	2.00	0.0

Link Summary

Name	From Node	To Node	Type	Length	%

101-MV	MH101	MHST47195	CONDUIT	17.1	
0.2918	0.0130				
102-101	MH102	MH101	CONDUIT	11.3	
0.2661	0.0130				
103-102	MH103	MH102	CONDUIT	22.4	
0.3131	0.0130				
104-103	MH104	MH103	CONDUIT	29.9	
0.2676	0.0130				
105-104	MH105	MH104	CONDUIT	57.7	
1.9950	0.0130				
106-105	MH106	MH105	CONDUIT	13.1	
2.9892	0.0130				
107-106	MH107	MH106	CONDUIT	17.3	3.00

OCB013	CB013	MH304	ORIFICE					
OCB014	CB014	MH304	ORIFICE					
OCB017	CB017	MH308	ORIFICE					
OCB018	CB018	MH308	ORIFICE					
OCB021	CB021	MH310	ORIFICE					
OHP01	PH01-STOR	MH103	ORIFICE					
OPH02	PH02-STOR	MH104	ORIFICE					
OPH03	PH03-STOR	MH106	ORIFICE					
OPH04a	PH04-STOR	495_(STM)	ORIFICE					
OPH04b	PH04-STOR	495_(STM)	ORIFICE					
OPH05a	PH05-STOR	573_(STM)	ORIFICE					
OPH05b	PH05-STOR	573_(STM)	ORIFICE					
OPH06a	PH06-STOR	502_(STM)	ORIFICE					
OPH06b	PH06-STOR	502_(STM)	ORIFICE					
OPH07	PH07-STOR	MH309	ORIFICE					
OPH08	PH08-STOR	MH307	ORIFICE					
OPH09	PH09-STOR	MH305	ORIFICE					
OPH10	PH10-STOR	MH302	ORIFICE					
OPH11	PH11-STOR	MH304	ORIFICE					
W1	PH01-STOR	SU1	WEIR					
OCB003	CB003	MH104	OUTLET					
OCB004	CB004	MH104	OUTLET					
OCB005	CB005	MH105	OUTLET					
OCB006	CB006	MH105	OUTLET					
OCB007	CB007	MH107	OUTLET					
OCB008	CB008	MH107	OUTLET					
OCB009	CB009	MH108	OUTLET					
OCB010	CB010	MH108	OUTLET					
OCB011	CB011	MH109	OUTLET					
OCB012	CB012	MH109	OUTLET					
OCB015	CB015	MH307	OUTLET					
OCB016	CB016	MH307	OUTLET					
OCB019	CB019	MH311	OUTLET					
OCB020	CB020	MH311	OUTLET					

Cross Section Summary							

Full			Full	Full	Hyd.	Max.	No. of
Conduit	Shape	Depth	Area	Rad.	Width	Barrels	
Flow							

101-MV	CIRCULAR	0.68	0.36	0.17	0.68	1	
454.12							
102-101	CIRCULAR	0.68	0.36	0.17	0.68	1	
433.60							
103-102	CIRCULAR	0.60	0.28	0.15	0.60	1	
343.60							
104-103	CIRCULAR	0.53	0.22	0.13	0.53	1	
222.47							
105-104	CIRCULAR	0.38	0.11	0.09	0.38	1	
247.66							
106-105	CIRCULAR	0.30	0.07	0.07	0.30	1	
167.20							
107-106	CIRCULAR	0.30	0.07	0.07	0.30	1	

108-107	CIRCULAR	0.30	0.07	0.07	0.30	1
167.01						
109-108	CIRCULAR	0.30	0.07	0.07	0.30	1
167.36						
301-MV	CIRCULAR	0.75	0.44	0.19	0.75	1
536.38						
302-301	CIRCULAR	0.68	0.36	0.17	0.68	1
74.70						
303-302	CIRCULAR	0.68	0.36	0.17	0.68	1
378.34						
304-303	CIRCULAR	0.68	0.36	0.17	0.68	1
342.95						
305-304	CIRCULAR	0.60	0.28	0.15	0.60	1
249.81						
306-305	CIRCULAR	0.53	0.22	0.13	0.53	1
200.73						
307-306	CIRCULAR	0.53	0.22	0.13	0.53	1
189.70						
308-307	CIRCULAR	0.45	0.16	0.11	0.45	1
155.06						
309-308	CIRCULAR	0.38	0.11	0.09	0.38	1
217.42						
310-309	CIRCULAR	0.30	0.07	0.07	0.30	1
133.43						
311-310	CIRCULAR	0.30	0.07	0.07	0.30	1
136.83						
C1	RECT_OPEN	0.35	2.45	0.32	7.00	1
6095.17						
C10	ROW-R-NoPark	0.35	1.72	0.18	9.50	1
6949.47						
C11	ROW-L-NoPark	0.35	1.72	0.19	9.50	1
7541.87						
C12	ROW-L-NoPark	0.35	1.72	0.19	9.50	1
6251.92						
C13	ROW-R-NoPark	0.35	1.72	0.18	9.50	1
6054.35						
C14	ROW-L-NoPark	0.35	1.72	0.19	9.50	1
4830.78						
C15	ROW-L-NoPark	0.35	1.72	0.19	9.50	1
2576.19						
C16	CIRCULAR	1.00	0.79	0.25	1.00	1
136.77						
C16_1	ROW-R-NoPark	0.35	1.72	0.18	9.50	1
4715.32						
C16_2	ROW-R-Park	0.35	2.36	0.22	12.00	1
7509.95						
C17	ROW-R-Park	0.35	2.36	0.22	12.00	1
4008.73						
C18	ROW-R-NoPark	0.35	1.72	0.18	9.50	1
4679.79						
C19	ROW-L-NoPark	0.35	1.72	0.19	9.50	1
4833.96						
C2	ROW-R-NoPark	0.35	1.72	0.18	9.50	1
4841.53						
C20	RECT_OPEN	0.35	1.75	0.31	5.00	1
388.67						
C20_1	ROW-R-NoPark	0.35	1.72	0.18	9.50	1
4169.54						
C20_2	ROW-R-Park	0.35	2.36	0.22	12.00	1
6644.47						

C21	ROW-L-NoPark	0.35	1.72	0.19	9.50	1
4478.17						
C22	ROW-L-Park	0.35	2.36	0.23	12.00	1
4025.51						
C23	ROW-R-NoPark	0.35	1.72	0.18	9.50	1
2467.90						
C24	ROW-R-Park	0.35	2.36	0.22	12.00	1
6831.88						
C25	ROW-L-NoPark	0.35	1.72	0.19	9.50	1
4432.61						
C26	RECT_OPEN	0.35	1.75	0.31	5.00	1
388.67						
C26_1	ROW-R-Park	0.35	2.36	0.22	12.00	1
7266.70						
C26_2	ROW-R-NoPark	0.35	1.72	0.18	9.50	1
4556.76						
C27	ROW-L-NoPark	0.35	1.72	0.19	9.50	1
4723.43						
C28	ROW-L-NoPark	0.35	1.72	0.19	9.50	1
2654.32						
C29	ROW-L-NoPark	0.35	1.72	0.19	9.50	1
2605.88						
C3	ROW-L-NoPark	0.35	1.72	0.19	9.50	1
4995.30						
C30	ROW-R-NoPark	0.35	1.72	0.18	9.50	1
1617.47						
C31	ROW-R-NoPark	0.35	1.72	0.18	9.50	1
2708.36						
C32	RECT_OPEN	0.35	1.75	0.31	5.00	1
388.67						
C4	ROW-L-NoPark	0.35	1.72	0.19	9.50	1
6663.03						
C5	ROW-R-NoPark	0.35	1.72	0.18	9.50	1
6452.33						
C6	ROW-L-NoPark	0.35	1.72	0.19	9.50	1
7841.13						
C7	RECT_OPEN	0.35	2.45	0.32	7.00	1
9151.84						
C7_1	ROW-R-Park	0.35	2.36	0.22	12.00	1
11533.26						
C7_2	ROW-R-NoPark	0.35	1.72	0.18	9.50	1
7238.83						
C8	ROW-R-NoPark	0.35	1.72	0.18	9.50	1
7303.33						
C9	ROW-R-NoPark	0.35	1.72	0.18	9.50	1
6333.69						
ParkSwale	TRIANGULAR	0.30	0.27	0.14	1.80	1
210.86						
STM-206_(STM)	CIRCULAR	0.30	0.07	0.07	0.30	1
131.52						
STM-211_(1)_(STM)	CIRCULAR	0.30	0.07	0.07	0.30	1
188.02						
STM-211_(STM)	CIRCULAR	0.30	0.07	0.07	0.30	1
186.81						
STM-263_(STM)	CIRCULAR	0.30	0.07	0.07	0.30	1
125.73						
STM-264_(STM)	CIRCULAR	0.30	0.07	0.07	0.30	1
218.97						

```

*****
Transect Summary
*****

Transect ROW-L-NoPark
Area:
    0.0005  0.0020  0.0045  0.0080  0.0125
    0.0180  0.0245  0.0320  0.0404  0.0499
    0.0604  0.0719  0.0844  0.0979  0.1121
    0.1263  0.1406  0.1549  0.1692  0.1834
    0.1977  0.2124  0.2297  0.2485  0.2681
    0.2883  0.3094  0.3312  0.3537  0.3770
    0.4010  0.4258  0.4513  0.4776  0.5046
    0.5324  0.5609  0.5902  0.6202  0.6510
    0.6825  0.7148  0.7478  0.7816  0.8161
    0.8514  0.8874  0.9242  0.9617  1.0000

Hrad:
    0.0182  0.0364  0.0546  0.0727  0.0909
    0.1091  0.1273  0.1455  0.1637  0.1818
    0.2000  0.2182  0.2364  0.2546  0.2853
    0.3210  0.3566  0.3920  0.4273  0.4625
    0.4975  0.4819  0.4544  0.4893  0.5222
    0.5533  0.5828  0.6108  0.6374  0.6626
    0.6867  0.7096  0.7315  0.7524  0.7725
    0.7917  0.8102  0.8279  0.8450  0.8615
    0.8774  0.8927  0.9076  0.9219  0.9359
    0.9494  0.9626  0.9754  0.9879  1.0000

Width:
    0.0258  0.0517  0.0775  0.1034  0.1292
    0.1550  0.1809  0.2067  0.2325  0.2584
    0.2842  0.3101  0.3359  0.3617  0.3692
    0.3692  0.3693  0.3693  0.3694  0.3694
    0.3695  0.4112  0.4765  0.4958  0.5152
    0.5346  0.5540  0.5734  0.5928  0.6122
    0.6316  0.6510  0.6704  0.6898  0.7091
    0.7285  0.7479  0.7673  0.7867  0.8061
    0.8255  0.8449  0.8643  0.8837  0.9030
    0.9224  0.9418  0.9612  0.9806  1.0000

Transect ROW-L-Park
Area:
    0.0009  0.0035  0.0079  0.0141  0.0221
    0.0318  0.0433  0.0561  0.0697  0.0841
    0.0991  0.1149  0.1314  0.1487  0.1665
    0.1843  0.2021  0.2199  0.2378  0.2556
    0.2734  0.2913  0.3091  0.3269  0.3447
    0.3626  0.3804  0.3983  0.4163  0.4360
    0.4572  0.4791  0.5017  0.5251  0.5492
    0.5741  0.5997  0.6260  0.6531  0.6809
    0.7095  0.7388  0.7688  0.7996  0.8312
    0.8635  0.8965  0.9302  0.9648  1.0000

Hrad:
    0.0151  0.0302  0.0453  0.0605  0.0756
    0.0907  0.1058  0.1280  0.1505  0.1723
    0.1933  0.2138  0.2338  0.2533  0.2800
    0.3096  0.3391  0.3686  0.3980  0.4274
    0.4567  0.4859  0.5151  0.5442  0.5732
    
```

Width:

0.6021	0.6310	0.6599	0.6575	0.6219
0.6508	0.6782	0.7043	0.7290	0.7525
0.7749	0.7962	0.8165	0.8359	0.8543
0.8719	0.8887	0.9047	0.9201	0.9348
0.9489	0.9624	0.9755	0.9880	1.0000

0.0496	0.0992	0.1487	0.1983	0.2479
0.2975	0.3471	0.3717	0.3922	0.4126
0.4331	0.4535	0.4740	0.4944	0.5003
0.5003	0.5004	0.5004	0.5005	0.5005
0.5005	0.5006	0.5006	0.5007	0.5007
0.5007	0.5008	0.5008	0.5256	0.5833
0.6042	0.6250	0.6458	0.6667	0.6875
0.7083	0.7292	0.7500	0.7708	0.7917
0.8125	0.8333	0.8542	0.8750	0.8958
0.9167	0.9375	0.9583	0.9792	1.0000

Transect ROW-R-NoPark
Area:

0.0005	0.0020	0.0045	0.0080	0.0125
0.0180	0.0245	0.0320	0.0404	0.0499
0.0604	0.0719	0.0844	0.0979	0.1121
0.1263	0.1406	0.1549	0.1692	0.1834
0.1977	0.2124	0.2297	0.2485	0.2681
0.2883	0.3094	0.3312	0.3537	0.3770
0.4010	0.4258	0.4513	0.4776	0.5046
0.5324	0.5609	0.5902	0.6202	0.6510
0.6825	0.7148	0.7478	0.7816	0.8161
0.8514	0.8874	0.9242	0.9617	1.0000

Hrad:

0.0191	0.0382	0.0572	0.0763	0.0954
0.1145	0.1336	0.1526	0.1717	0.1908
0.2099	0.2290	0.2481	0.2671	0.2990
0.3358	0.3723	0.4085	0.4444	0.4801
0.5155	0.4991	0.4706	0.5060	0.5393
0.5706	0.6001	0.6280	0.6544	0.6794
0.7030	0.7255	0.7469	0.7672	0.7866
0.8051	0.8228	0.8398	0.8560	0.8716
0.8866	0.9010	0.9149	0.9283	0.9412
0.9537	0.9658	0.9776	0.9889	1.0000

Width:

0.0258	0.0517	0.0775	0.1034	0.1292
0.1550	0.1809	0.2067	0.2325	0.2584
0.2842	0.3101	0.3359	0.3617	0.3692
0.3692	0.3693	0.3693	0.3694	0.3694
0.3695	0.4112	0.4765	0.4958	0.5152
0.5346	0.5540	0.5734	0.5928	0.6122
0.6316	0.6510	0.6704	0.6898	0.7091
0.7285	0.7479	0.7673	0.7867	0.8061
0.8255	0.8449	0.8643	0.8837	0.9030
0.9224	0.9418	0.9612	0.9806	1.0000

Transect ROW-R-Park
Area:

0.0009	0.0035	0.0079	0.0141	0.0221
0.0318	0.0433	0.0561	0.0697	0.0841
0.0991	0.1149	0.1314	0.1487	0.1665

0.1843	0.2021	0.2199	0.2378	0.2556
0.2734	0.2913	0.3091	0.3269	0.3447
0.3626	0.3804	0.3983	0.4163	0.4360
0.4572	0.4791	0.5017	0.5251	0.5492
0.5741	0.5997	0.6260	0.6531	0.6809
0.7095	0.7388	0.7688	0.7996	0.8312
0.8635	0.8965	0.9302	0.9648	1.0000

Hrad:

0.0156	0.0313	0.0469	0.0625	0.0781
0.0938	0.1094	0.1323	0.1556	0.1781
0.1999	0.2210	0.2417	0.2619	0.2892
0.3195	0.3496	0.3795	0.4093	0.4390
0.4686	0.4980	0.5273	0.5564	0.5854
0.6143	0.6431	0.6718	0.6692	0.6332
0.6620	0.6892	0.7150	0.7395	0.7626
0.7846	0.8054	0.8251	0.8439	0.8617
0.8786	0.8948	0.9101	0.9248	0.9388
0.9521	0.9649	0.9771	0.9888	1.0000

Width:

0.0496	0.0992	0.1487	0.1983	0.2479
0.2975	0.3471	0.3717	0.3922	0.4126
0.4331	0.4535	0.4740	0.4944	0.5003
0.5003	0.5004	0.5004	0.5005	0.5005
0.5005	0.5006	0.5006	0.5007	0.5007
0.5007	0.5008	0.5008	0.5256	0.5833
0.6042	0.6250	0.6458	0.6667	0.6875
0.7083	0.7292	0.7500	0.7708	0.7917
0.8125	0.8333	0.8542	0.8750	0.8958
0.9167	0.9375	0.9583	0.9792	1.0000

```

*****
Analysis Options
*****
Flow Units ..... LPS
Process Models:
  Rainfall/Runoff ..... YES
  RDII ..... NO
  Snowmelt ..... NO
  Groundwater ..... NO
  Flow Routing ..... YES
  Ponding Allowed ..... NO
  Water Quality ..... NO
  Infiltration Method ..... HORTON
  Flow Routing Method ..... DYNWAVE
  Surcharge Method ..... EXTRAN
Starting Date ..... 11/21/2022 00:00:00
Ending Date ..... 11/22/2022 00:00:00
Antecedent Dry Days ..... 0.0
Report Time Step ..... 00:01:00
Wet Time Step ..... 00:01:00
Dry Time Step ..... 00:01:00
Routing Time Step ..... 2.00 sec
Variable Time Step ..... YES
Maximum Trials ..... 8
Number of Threads ..... 8
Head Tolerance ..... 0.001500 m

```

```

*****
Volume      Depth
Runoff Quantity Continuity  hectare-m    mm
*****
Initial LID Storage .....  0.007      1.103
Total Precipitation .....  0.434      71.667
Evaporation Loss .....    0.000      0.000
Infiltration Loss .....    0.086     14.162
Surface Runoff .....       0.349     57.561
Final Storage .....       0.007      1.104
Continuity Error (%) ..... -0.079
    
```

```

*****
Volume      Volume
Flow Routing Continuity    hectare-m    10^6 ltr
*****
Dry Weather Inflow .....    0.000      0.000
Wet Weather Inflow .....    0.349      3.486
Groundwater Inflow .....    0.000      0.000
RDII Inflow .....         0.000      0.000
External Inflow .....      0.178      1.777
External Outflow .....     0.526      5.258
Flooding Loss .....        0.000      0.000
Evaporation Loss .....     0.000      0.000
Exfiltration Loss .....    0.000      0.000
Initial Stored Volume ....  0.182      1.816
Final Stored Volume .....  0.183      1.827
Continuity Error (%) ..... -0.087
    
```

```

*****
Highest Continuity Errors
*****
Node J12 (18.26%)
Node CB020 (-4.30%)
Node CB019 (1.04%)
    
```

```

*****
Time-Step Critical Elements
*****
Link STM-211_(1)_(STM) (4.80%)
    
```

```

*****
Highest Flow Instability Indexes
*****
Link OCB017 (122)
Link OCB018 (115)
Link OCB001 (102)
Link OCB002 (102)
Link OHP01 (75)
    
```

```

*****
Most Frequent Nonconverging Nodes
    
```

```

*****
Node 300_(STM) (0.01%)
Node DR-M (0.01%)
Node J4 (0.01%)
Node J5 (0.01%)
Node MHST27978 (0.01%)
    
```

```

*****
Routing Time Step Summary
*****
Minimum Time Step      : 0.83 sec
Average Time Step      : 1.99 sec
Maximum Time Step      : 2.00 sec
% of Time in Steady State : 0.00
Average Iterations per Step : 2.00
% of Steps Not Converging : 0.01
Time Step Frequencies :
2.000 - 1.516 sec : 99.99 %
1.516 - 1.149 sec : 0.00 %
1.149 - 0.871 sec : 0.00 %
0.871 - 0.660 sec : 0.00 %
0.660 - 0.500 sec : 0.00 %
    
```

```

*****
Subcatchment Runoff Summary
*****
    
```

Perv	Total Runoff mm	Total Runoff mm	Total Precip Runoff mm	Total Peak Runoff LPS	Total Runoff Coeff	Total Evap mm	Total Infil mm	Imperv Runoff mm
A01a	4.79	64.37	0.05	71.67	0.00	0.00	7.41	59.58
A01b	13.76	49.65	0.06	38.24	0.898	0.00	22.10	35.89
A02a	7.32	60.44	0.03	71.67	0.00	0.00	11.34	53.12
A02b	6.45	61.73	0.04	20.54	0.843	0.00	10.06	55.27
A03a	3.68	66.13	0.02	71.67	0.00	0.00	5.66	62.45
A03b	5.90	62.61	0.03	16.08	0.923	0.00	9.17	56.71
A04a	1.70	69.16	0.06	71.67	0.00	0.00	2.61	67.46
A04b	6.43	61.70	0.04	40.34	0.965	0.00	10.08	55.27
A05a	0.00	71.77	0.06	71.67	0.00	0.00	0.00	71.77
A05b	5.90	62.61	0.04	38.69	1.001	0.00	9.18	56.71
				71.67	0.00			
				32.68	0.874			

A06a			71.67	0.00	0.00	0.00	71.78
0.00	71.78	0.03	20.83	1.002			
A06b			71.67	0.00	0.00	10.06	55.27
6.45	61.73	0.02	18.67	0.861			
B01a			71.67	0.00	0.00	4.79	63.88
3.11	66.99	0.07	48.36	0.935			
B01b			71.67	0.00	0.00	6.09	61.73
3.96	65.70	0.03	24.32	0.917			
B02a			71.67	0.00	0.00	3.91	65.32
2.55	67.88	0.02	14.21	0.947			
B02b			71.67	0.00	0.00	0.00	71.78
0.00	71.78	0.01	8.93	1.002			
B03a			71.67	0.00	0.00	3.05	66.75
1.98	68.73	0.09	67.79	0.959			
B03b			71.67	0.00	0.00	14.81	47.35
9.60	56.96	0.03	25.51	0.795			
B04a			71.67	0.00	0.00	0.00	71.74
0.00	71.74	0.01	3.47	1.001			
B04b			71.67	0.00	0.00	15.69	45.92
10.16	56.08	0.01	5.18	0.783			
B-05			71.67	0.00	0.00	2.61	67.46
1.70	69.16	0.09	63.95	0.965			
BLDG01			71.67	0.00	0.00	0.00	71.72
0.00	71.72	0.11	74.79	1.001			
P01-1			71.67	0.00	0.00	29.77	31.57
41.97	41.97	0.04	34.88	0.586			
P01-2			71.67	0.00	0.00	22.60	42.35
49.18	49.18	0.02	14.54	0.686			
PH02			71.67	0.00	0.00	18.37	43.04
10.30	53.35	0.22	155.27	0.744			
PH03			71.67	0.00	0.00	44.16	7.18
20.35	27.53	0.04	19.72	0.384			
PH04			71.67	0.00	0.00	0.00	71.69
0.00	71.69	0.17	115.84	1.000			
PH05			71.67	0.00	0.00	8.74	58.08
4.89	62.97	0.39	269.32	0.879			
PH06			71.67	0.00	0.00	12.94	51.63
7.14	58.77	0.28	193.88	0.820			
PH07			71.67	0.00	0.00	14.21	49.49
8.02	57.50	0.18	125.71	0.802			
PH08			71.67	0.00	0.00	15.00	48.06
8.66	56.72	0.18	134.12	0.791			
PH09			71.67	0.00	0.00	10.85	55.21
5.64	60.85	0.37	245.37	0.849			
PH10			71.67	0.00	0.00	15.97	48.04
7.68	55.72	0.35	229.40	0.778			
PH11			71.67	0.00	0.00	10.80	54.51
6.41	60.92	0.12	88.93	0.850			
xD-02			71.67	0.00	0.00	0.00	71.78
0.00	71.78	0.00	1.98	1.002			
xD-04			71.67	0.00	0.00	44.09	0.00
27.65	27.65	0.00	4.12	0.386			
xPARK01			71.67	0.00	0.00	36.38	20.81
35.33	35.33	0.18	119.47	0.493			

Node Depth Summary

Node	Type	Average Depth Meters	Maximum Depth Meters	Maximum HGL Meters	Time of Max Occurrence days hr:min	Reported Max Depth Meters
495_(STM)	JUNCTION	0.02	0.04	99.40	0 02:02	0.04
502_(STM)	JUNCTION	0.13	0.18	97.90	0 01:53	0.18
503_(STM)	JUNCTION	0.37	0.38	99.37	0 00:00	0.38
573_(STM)	JUNCTION	0.61	0.65	99.40	0 00:00	0.62
CB001	JUNCTION	1.36	1.48	94.15	0 01:10	1.48
CB002	JUNCTION	1.26	1.38	94.15	0 01:10	1.38
CB003	JUNCTION	0.00	0.05	94.93	0 01:10	0.05
CB004	JUNCTION	0.00	0.06	94.94	0 01:10	0.06
CB005	JUNCTION	0.00	0.04	96.34	0 01:10	0.04
CB006	JUNCTION	0.00	0.05	96.35	0 01:10	0.05
CB007	JUNCTION	0.00	0.04	97.71	0 01:10	0.04
CB008	JUNCTION	0.00	0.04	97.71	0 01:10	0.04
CB009	JUNCTION	0.00	0.03	99.79	0 01:10	0.03
CB010	JUNCTION	0.00	0.04	99.80	0 01:10	0.04
CB011	JUNCTION	0.00	0.03	101.40	0 01:10	0.03
CB012	JUNCTION	0.00	0.03	101.40	0 01:10	0.03
CB013	JUNCTION	1.36	1.40	94.64	0 01:10	1.40
CB014	JUNCTION	1.36	1.40	94.64	0 01:10	1.40
CB015	JUNCTION	0.00	0.02	95.44	0 01:10	0.02
CB016	JUNCTION	0.00	0.02	95.44	0 01:10	0.02
CB017	JUNCTION	0.87	1.94	95.84	0 01:11	1.94
CB018	JUNCTION	0.87	1.94	95.84	0 01:11	1.94
CB019	JUNCTION	0.00	0.01	96.81	0 01:08	0.01
CB020	JUNCTION	0.00	0.02	96.82	0 01:10	0.02
CB021	JUNCTION	0.04	1.41	96.76	0 01:12	1.41
CB110	JUNCTION	1.14	1.42	94.31	0 01:11	1.41
CB112	JUNCTION	1.27	1.31	94.63	0 01:10	1.31
J1	JUNCTION	0.05	0.09	94.64	0 01:10	0.09
J10	JUNCTION	0.00	0.03	94.49	0 01:10	0.03
J11	JUNCTION	0.00	0.03	94.94	0 01:10	0.03
J12	JUNCTION	0.00	0.01	96.38	0 01:13	0.01
J13	JUNCTION	0.00	0.00	96.95	0 00:00	0.00
J2	JUNCTION	0.00	0.00	95.84	0 00:00	0.00
J3	JUNCTION	0.00	0.00	95.84	0 00:00	0.00
J6	JUNCTION	0.01	0.25	96.04	0 01:13	0.25
J7	JUNCTION	0.00	0.05	97.21	0 01:10	0.05
J8	JUNCTION	0.00	0.00	97.16	0 00:00	0.00
J9	JUNCTION	0.00	0.04	98.35	0 01:08	0.04
300_(STM)	OUTFALL	2.62	2.62	94.74	0 00:00	2.62
DR-M	OUTFALL	0.00	0.00	0.00	0 00:00	0.00
J4	OUTFALL	0.00	0.00	101.95	0 00:00	0.00
J5	OUTFALL	0.00	0.00	101.95	0 00:00	0.00
MHST27978	OUTFALL	0.58	0.58	97.86	0 00:00	0.58
MHST27980	OUTFALL	1.46	1.46	99.36	0 00:00	1.46
MHST47195	OUTFALL	2.53	2.53	94.03	0 00:00	2.53
OF1	OUTFALL	0.00	0.07	94.14	0 01:10	0.07
OF2	OUTFALL	0.00	0.06	94.13	0 01:10	0.06
OF3	OUTFALL	0.04	0.08	94.63	0 01:10	0.08
OF4	OUTFALL	0.03	0.06	94.61	0 01:10	0.06
MH101	STORAGE	1.80	1.86	94.09	0 01:11	1.86
MH102	STORAGE	1.76	1.83	94.10	0 01:11	1.83
MH103	STORAGE	1.61	1.72	94.14	0 01:10	1.72

MH104	STORAGE	1.45	1.68	94.26	0	01:11	1.68
MH105	STORAGE	0.16	0.68	94.56	0	01:10	0.67
MH106	STORAGE	0.01	0.32	94.67	0	01:10	0.30
MH107	STORAGE	0.01	0.16	95.04	0	01:10	0.16
MH108	STORAGE	0.01	0.12	96.01	0	01:10	0.12
MH109	STORAGE	0.00	0.07	98.70	0	01:10	0.07
MH301	STORAGE	2.12	2.13	94.75	0	01:10	2.13
MH302	STORAGE	2.04	2.05	94.75	0	01:10	2.05
MH303	STORAGE	1.99	2.00	94.75	0	01:10	2.00
MH304	STORAGE	1.94	1.95	94.75	0	01:02	1.95
MH305	STORAGE	1.85	1.87	94.76	0	01:02	1.86
MH306	STORAGE	1.73	1.76	94.77	0	01:02	1.76
MH307	STORAGE	1.67	1.72	94.79	0	01:10	1.72
MH308	STORAGE	1.41	1.52	94.85	0	01:10	1.52
MH309	STORAGE	1.00	1.13	94.87	0	01:10	1.13
MH310	STORAGE	0.72	0.87	94.89	0	01:10	0.87
MH311	STORAGE	0.00	0.04	94.93	0	01:10	0.04
PH01-STOR	STORAGE	1.16	1.88	94.88	0	01:51	1.88
PH02-STOR	STORAGE	1.14	1.87	94.87	0	01:46	1.87
PH03-STOR	STORAGE	0.08	0.86	95.26	0	01:52	0.86
PH04-STOR	STORAGE	0.41	1.53	101.03	0	02:02	1.53
PH05-STOR	STORAGE	0.61	1.64	100.64	0	01:57	1.64
PH06-STOR	STORAGE	0.47	1.70	99.50	0	01:52	1.70
PH07-STOR	STORAGE	0.66	1.93	96.23	0	01:49	1.93
PH08-STOR	STORAGE	1.18	1.86	95.56	0	01:53	1.86
PH09-STOR	STORAGE	1.37	1.97	95.47	0	02:00	1.97
PH10-STOR	STORAGE	1.36	1.95	95.45	0	01:59	1.95
PH11-STOR	STORAGE	1.35	1.75	95.25	0	02:00	1.75
SU1	STORAGE	0.00	0.00	93.00	0	00:00	0.00

Node Inflow Summary

Total	Flow		Maximum	Maximum		Lateral	
Inflow	Balance		Lateral	Total	Time of Max	Inflow	
Volume	Error	Type	Inflow	Inflow	Occurrence	Volume	
Node	Percent		LPS	LPS	days hr:min	10^6 ltr	10^6
ltr							
495_(STM)		JUNCTION	0.00	7.73	0 02:02	0	
0.173	0.016						
502_(STM)		JUNCTION	0.00	43.91	0 01:54	0	
0.872	0.504						
503_(STM)		JUNCTION	0.00	0.07	0 00:01	0	
0.00041	16.638						
573_(STM)		JUNCTION	0.00	18.44	0 01:57	0	
0.39	-0.013						
CB001		JUNCTION	38.24	109.23	0 01:10	0.0509	
0.0999	0.052						
CB002		JUNCTION	49.44	100.11	0 01:10	0.0566	
0.000	0.000						

CB003		JUNCTION	20.54	46.52	0 01:10	0.026	
0.0508	-0.037						
CB004		JUNCTION	32.56	70.78	0 01:10	0.042	
0.0719	-0.397						
CB005		JUNCTION	16.08	45.39	0 01:10	0.0218	
0.0554	0.003						
CB006		JUNCTION	22.11	57.85	0 01:10	0.0288	
0.0615	-0.053						
CB007		JUNCTION	40.34	75.76	0 01:10	0.0567	
0.101	-0.022						
CB008		JUNCTION	31.51	55.26	0 01:10	0.0407	
0.0651	-0.006						
CB009		JUNCTION	38.69	48.49	0 01:10	0.056	
0.0676	-0.063						
CB010		JUNCTION	32.68	41.26	0 01:10	0.0426	
0.0514	-0.010						
CB011		JUNCTION	20.83	20.83	0 01:10	0.0301	
0.0301	-0.017						
CB012		JUNCTION	18.67	18.67	0 01:10	0.0241	
0.0241	-0.014						
CB013		JUNCTION	48.36	72.95	0 01:10	0.0663	
1.69	-0.000						
CB014		JUNCTION	24.32	66.27	0 01:10	0.0328	
1.46	0.001						
CB015		JUNCTION	14.21	14.21	0 01:10	0.0197	
0.0197	-0.168						
CB016		JUNCTION	8.93	8.93	0 01:10	0.0129	
0.0129	-0.105						
CB017		JUNCTION	67.79	67.90	0 01:10	0.0949	
0.0965	0.116						
CB018		JUNCTION	25.51	65.80	0 01:09	0.0308	
0.0434	0.188						
CB019		JUNCTION	3.47	28.89	0 01:10	0.00502	
0.0351	1.047						
CB020		JUNCTION	5.18	5.18	0 01:10	0.00617	
0.00617	-4.120						
CB021		JUNCTION	63.95	90.19	0 01:10	0.0899	
0.121	-0.312						
CB110		JUNCTION	0.00	103.74	0 01:13	0	
0.184	0.000						
CB112		JUNCTION	0.00	37.92	0 01:10	0	
0.747	0.001						
J1		JUNCTION	0.00	38.20	0 01:10	0	
0.746	-0.000						
J10		JUNCTION	0.00	27.07	0 01:10	0	
0.0204	-0.361						
J11		JUNCTION	0.00	7.94	0 01:10	0	
0.00895	0.485						
J12		JUNCTION	0.00	0.51	0 01:10	0	
0.000393	22.333						
J13		JUNCTION	0.00	0.00	0 00:00	0	
0	0.000 ltr						
J2		JUNCTION	0.00	0.00	0 00:00	0	
0	0.000 ltr						
J3		JUNCTION	0.00	0.00	0 00:00	0	
0	0.000 ltr						
J6		JUNCTION	119.47	119.47	0 01:10	0.183	
0.183	-0.021						
J7		JUNCTION	0.00	25.42	0 01:10	0	
0.0301	0.012						

J8		JUNCTION	0.00	0.00	0	00:00	0
0	0.000 ltr						
J9		JUNCTION	0.00	35.42	0	01:10	0
0.0442	0.118						
300_ (STM)		OUTFALL	0.00	117.05	0	01:10	0
2.08	0.000						
DR-M		OUTFALL	6.11	6.11	0	01:10	0.00583
0.00583	0.000						
J4		OUTFALL	0.00	0.00	0	00:00	0
0	0.000 ltr						
J5		OUTFALL	0.00	0.00	0	00:00	0
0	0.000 ltr						
MHST27978		OUTFALL	0.00	64.84	0	01:54	0
1.29	0.000						
MHST27980		OUTFALL	0.00	18.43	0	01:58	0
0.389	0.000						
MHST47195		OUTFALL	0.00	272.39	0	01:11	0
0.971	0.000						
OF1		OUTFALL	0.00	44.91	0	01:10	0
0.0254	0.000						
OF2		OUTFALL	0.00	101.05	0	01:10	0
0.0582	0.000						
OF3		OUTFALL	0.00	65.12	0	01:10	0
1.46	0.000						
OF4		OUTFALL	0.00	37.80	0	01:10	0
0.746	0.000						
MH101		STORAGE	0.00	272.37	0	01:11	0
0.974	-0.000						
MH102		STORAGE	0.00	272.34	0	01:11	0
0.975	0.000						
MH103		STORAGE	0.00	273.18	0	01:11	0
0.986	0.004						
MH104		STORAGE	0.00	264.40	0	01:11	0
0.726	-0.017						
MH105		STORAGE	0.00	130.34	0	01:08	0
0.255	-0.063						
MH106		STORAGE	0.00	92.95	0	01:09	0
0.193	-0.077						
MH107		STORAGE	0.00	92.02	0	01:10	0
0.154	0.105						
MH108		STORAGE	0.00	51.61	0	01:10	0
0.0842	0.001						
MH109		STORAGE	0.00	21.10	0	01:10	0
0.0338	-0.002						
MH301		STORAGE	0.00	117.03	0	01:10	0
2.09	-0.001						
MH302		STORAGE	0.00	117.01	0	01:10	0
2.14	0.003						
MH303		STORAGE	0.00	103.42	0	01:10	0
1.84	-0.000						
MH304		STORAGE	0.00	125.23	0	01:10	0
2.54	0.000						
MH305		STORAGE	0.00	121.36	0	01:10	0
1.01	0.003						
MH306		STORAGE	0.00	108.43	0	01:10	0
0.641	0.000						
MH307		STORAGE	0.00	108.38	0	01:10	0
0.641	0.000						
MH308		STORAGE	0.00	91.00	0	01:11	0
0.439	-0.006						

MH309		STORAGE	0.00	53.51	0	01:11	0
0.308	0.001						
MH310		STORAGE	0.00	45.95	0	01:10	0
0.131	-0.001						
MH311		STORAGE	0.00	5.77	0	01:10	0
0.00875	0.001						
PH01-STOR		STORAGE	124.21	124.21	0	01:10	0.168
0.308	-0.002						
PH02-STOR		STORAGE	155.27	155.27	0	01:10	0.217
0.398	-0.000						
PH03-STOR		STORAGE	19.72	19.72	0	01:10	0.0388
0.039	-0.000						
PH04-STOR		STORAGE	115.84	115.84	0	01:10	0.173
0.174	0.000						
PH05-STOR		STORAGE	269.32	269.32	0	01:10	0.389
0.467	-0.000						
PH06-STOR		STORAGE	193.88	193.88	0	01:10	0.277
0.285	0.000						
PH07-STOR		STORAGE	125.71	125.71	0	01:10	0.177
0.212	-0.001						
PH08-STOR		STORAGE	134.12	134.12	0	01:10	0.184
0.353	-0.000						
PH09-STOR		STORAGE	245.37	245.37	0	01:10	0.366
0.802	-0.002						
PH10-STOR		STORAGE	229.40	229.40	0	01:10	0.35
0.769	-0.003						
PH11-STOR		STORAGE	88.93	88.93	0	01:10	0.122
0.34	-0.001						
SU1		STORAGE	0.00	0.00	0	00:00	0
0	0.000 ltr						

Node Surcharge Summary

Surcharging occurs when water rises above the top of the highest conduit.

Node	Type	Hours Surcharged	Max. Height Above Crown Meters	Min. Depth Below Rim Meters
503_ (STM)	JUNCTION	24.00	0.083	1.947
573_ (STM)	JUNCTION	24.00	0.079	1.094
MH101	STORAGE	24.00	1.172	0.000
MH102	STORAGE	24.00	1.149	0.000
MH103	STORAGE	24.00	1.119	0.000
MH301	STORAGE	24.00	1.372	0.000
MH302	STORAGE	24.00	1.343	0.000
MH303	STORAGE	24.00	1.295	0.000
MH304	STORAGE	24.00	1.273	0.000
MH305	STORAGE	24.00	1.265	0.000

Node Flooding Summary

No nodes were flooded.

Storage Volume Summary

Max Occurrence	Maximum Outflow Storage Unit	Average Volume	Avg Pcnt Full	Evap Pcnt Loss	Exfil Pcnt Loss	Maximum Volume	Max Pcnt Full	Time of days
hr:min	LPS	1000 m ³				1000 m ³		
MH101		0.003	98.4	0.0	0.0	0.003	100.0	0
01:04	272.39							
MH102		0.004	97.3	0.0	0.0	0.005	100.0	0
01:07	272.37							
MH103		0.003	98.2	0.0	0.0	0.003	100.0	0
01:01	273.76							
MH104		0.003	69.2	0.0	0.0	0.003	79.9	0
01:11	266.06							
MH105		0.000	5.8	0.0	0.0	0.001	25.2	0
01:10	128.01							
MH106		0.000	0.4	0.0	0.0	0.000	11.2	0
01:10	91.54							
MH107		0.000	0.2	0.0	0.0	0.000	5.1	0
01:10	92.02							
MH108		0.000	0.2	0.0	0.0	0.000	4.3	0
01:10	51.60							
MH109		0.000	0.1	0.0	0.0	0.000	2.5	0
01:10	21.08							
MH301		0.002	100.0	0.0	0.0	0.002	100.0	0
00:00	117.05							
MH302		0.002	100.0	0.0	0.0	0.002	100.0	0
00:00	117.03							
MH303		0.002	100.0	0.0	0.0	0.002	100.0	0
00:00	103.44							
MH304		0.002	100.0	0.0	0.0	0.002	100.0	0
00:00	125.27							
MH305		0.002	100.0	0.0	0.0	0.002	100.0	0
00:00	121.38							
MH306		0.002	84.4	0.0	0.0	0.002	85.9	0
01:02	108.57							
MH307		0.002	63.5	0.0	0.0	0.002	65.3	0
01:10	108.43							
MH308		0.002	55.6	0.0	0.0	0.002	59.8	0
01:10	91.73							
MH309		0.001	39.7	0.0	0.0	0.001	44.6	0
01:10	53.81							
MH310		0.001	29.2	0.0	0.0	0.001	35.2	0
01:10	45.77							
MH311		0.000	0.1	0.0	0.0	0.000	1.8	0
01:10	5.77							
PH01-STOR		0.157	38.6	0.0	0.0	0.254	62.7	0
01:51	9.60							

Node	Flow Freq	Avg Flow LPS	Max Flow LPS	Total Volume 10 ⁶ ltr			
PH02-STOR	0.201	57.2	0.0	0.0	0.329	93.5	0
01:46	13.82						
PH03-STOR	0.002	3.8	0.0	0.0	0.023	43.2	0
01:52	4.20						
PH04-STOR	0.034	20.6	0.0	0.0	0.124	76.5	0
02:02	7.73						
PH05-STOR	0.133	30.7	0.0	0.0	0.355	82.0	0
01:57	18.41						
PH06-STOR	0.057	23.4	0.0	0.0	0.207	84.9	0
01:52	14.96						
PH07-STOR	0.054	33.1	0.0	0.0	0.157	96.6	0
01:49	10.26						
PH08-STOR	0.192	59.2	0.0	0.0	0.301	92.8	0
01:53	8.88						
PH09-STOR	0.482	68.6	0.0	0.0	0.691	98.3	0
02:00	17.37						
PH10-STOR	0.459	67.8	0.0	0.0	0.658	97.4	0
01:59	18.26						
PH11-STOR	0.237	67.4	0.0	0.0	0.308	87.6	0
02:00	4.89						
SU1	0.000	0.0	0.0	0.0	0.000	0.0	0
00:00	0.00						

Outfall Loading Summary

Outfall Node	Flow Freq Pcnt	Avg Flow LPS	Max Flow LPS	Total Volume 10 ⁶ ltr
300_(STM)	99.97	24.20	117.05	2.084
DR-M	12.63	0.54	6.11	0.006
J4	0.00	0.00	0.00	0.000
J5	0.00	0.00	0.00	0.000
MHST27978	99.13	15.20	64.84	1.290
MHST27980	70.63	6.43	18.43	0.389
MHST47195	52.46	21.68	272.39	0.971
OF1	2.24	13.23	44.91	0.025
OF2	2.34	29.05	101.05	0.058
OF3	100.00	16.96	65.12	1.465
OF4	100.00	8.64	37.80	0.746
System	49.04	135.93	698.27	7.034

Link Flow Summary

Link	Type	Maximum Flow LPS	Time of Max Occurrence days hr:min	Maximum Veloc m/sec	Max/Full Flow	Max/Full Depth
101-MV	CONDUIT	272.39	0 01:11	0.76	0.60	1.00

102-101	CONDUIT	272.37	0	01:11	0.76	0.63	1.00
103-102	CONDUIT	272.34	0	01:11	0.96	0.79	1.00
104-103	CONDUIT	266.06	0	01:11	1.23	1.20	1.00
105-104	CONDUIT	128.01	0	01:08	1.16	0.52	1.00
106-105	CONDUIT	91.54	0	01:08	1.56	0.55	1.00
107-106	CONDUIT	92.02	0	01:10	2.34	0.55	0.76
108-107	CONDUIT	51.60	0	01:10	2.06	0.31	0.38
109-108	CONDUIT	21.08	0	01:10	1.62	0.13	0.24
301-MV	CONDUIT	117.05	0	01:10	0.26	0.22	1.00
302-301	CONDUIT	117.03	0	01:10	0.33	1.57	1.00
303-302	CONDUIT	103.44	0	01:10	0.29	0.27	1.00
304-303	CONDUIT	103.42	0	01:10	0.29	0.30	1.00
305-304	CONDUIT	121.38	0	01:10	0.43	0.49	1.00
306-305	CONDUIT	108.57	0	01:10	0.50	0.54	1.00
307-306	CONDUIT	108.43	0	01:10	0.50	0.57	1.00
308-307	CONDUIT	91.73	0	01:11	0.58	0.59	1.00
309-308	CONDUIT	53.81	0	01:11	0.49	0.25	1.00
310-309	CONDUIT	45.77	0	01:10	0.65	0.34	1.00
311-310	CONDUIT	5.77	0	01:10	0.14	0.04	0.57
C1	CONDUIT	26.25	0	01:08	0.20	0.00	0.24
C10	CHANNEL	0.00	0	00:00	0.00	0.00	0.06
C11	CHANNEL	35.75	0	01:10	0.94	0.00	0.13
C12	CHANNEL	38.24	0	01:10	0.74	0.01	0.15
C13	CHANNEL	25.97	0	01:10	0.73	0.00	0.13
C14	CHANNEL	50.71	0	01:10	0.21	0.01	0.34
C15	CHANNEL	44.91	0	01:10	0.18	0.02	0.35
C16	CONDUIT	0.00	0	00:00	0.00	0.00	0.50
C16_1	CHANNEL	27.07	0	01:10	0.89	0.01	0.12
C16_2	CHANNEL	27.02	0	01:10	0.07	0.00	0.30
C17	CHANNEL	101.05	0	01:10	0.21	0.03	0.34
C18	CHANNEL	25.42	0	01:10	1.29	0.01	0.10
C19	CHANNEL	0.00	0	00:00	0.00	0.00	0.02
C2	CHANNEL	0.00	0	00:00	0.00	0.00	0.04
C20	CONDUIT	44.54	0	01:10	0.13	0.11	0.19
C20_1	CHANNEL	0.51	0	01:10	0.43	0.00	0.02
C20_2	CHANNEL	0.16	0	01:13	0.09	0.00	0.21
C21	CHANNEL	1.53	0	01:10	0.28	0.00	0.22
C22	CHANNEL	0.00	0	00:00	0.00	0.00	0.20
C23	CHANNEL	0.00	0	00:00	0.00	0.00	0.20
C24	CHANNEL	0.00	0	00:00	0.00	0.00	0.03
C25	CHANNEL	0.00	0	00:00	0.00	0.00	0.03
C26	CONDUIT	38.78	0	01:09	0.28	0.10	0.11
C26_1	CHANNEL	7.94	0	01:10	0.37	0.00	0.07
C26_2	CHANNEL	7.89	0	01:10	0.03	0.00	0.33
C27	CHANNEL	3.00	0	01:10	0.01	0.00	0.32
C28	CHANNEL	65.12	0	01:10	0.21	0.02	0.40
C29	CHANNEL	38.20	0	01:10	0.12	0.01	0.41
C3	CHANNEL	0.00	0	00:00	0.00	0.00	0.04
C30	CHANNEL	37.92	0	01:10	0.23	0.02	0.28
C31	CHANNEL	37.80	0	01:10	0.29	0.01	0.24
C32	CONDUIT	33.97	0	01:10	0.07	0.09	0.29
C4	CHANNEL	8.57	0	01:10	0.47	0.00	0.09
C5	CHANNEL	9.80	0	01:10	0.61	0.00	0.09
C6	CHANNEL	23.75	0	01:10	0.81	0.00	0.12
C7	CONDUIT	0.00	0	00:00	0.00	0.00	0.23
C7_1	CHANNEL	35.42	0	01:10	0.63	0.00	0.11
C7_2	CHANNEL	35.42	0	01:10	1.11	0.00	0.12

C8	CHANNEL	29.31	0	01:10	0.98	0.00	0.12
C9	CHANNEL	25.42	0	01:10	0.64	0.00	0.14
ParkSwale	CONDUIT	103.74	0	01:13	0.71	0.49	0.74
STM-206_(STM)	CONDUIT	104.13	0	01:13	1.47	0.79	1.00
STM-211_(1)_(STM)	CONDUIT	64.84	0	01:54	1.22	0.34	0.76
STM-211_(STM)	CONDUIT	7.73	0	02:02	0.75	0.04	0.37
STM-263_(STM)	CONDUIT	0.07	0	00:01	0.00	0.00	1.00
STM-264_(STM)	CONDUIT	18.43	0	01:58	0.26	0.08	1.00
OCB001	ORIFICE	8.72	0	01:05			1.00
OCB002	ORIFICE	12.11	0	01:05			1.00
OCB013	ORIFICE	18.94	0	01:34			1.00
OCB014	ORIFICE	5.65	0	01:34			1.00
OCB017	ORIFICE	22.45	0	01:13			1.00
OCB018	ORIFICE	14.87	0	01:13			1.00
OCB021	ORIFICE	40.35	0	01:12			1.00
OHP01	ORIFICE	9.60	0	01:53			1.00
OPH02	ORIFICE	13.82	0	01:52			1.00
OPH03	ORIFICE	4.20	0	01:52			1.00
OPH04a	ORIFICE	2.51	0	02:02			1.00
OPH04b	ORIFICE	5.23	0	02:02			1.00
OPH05a	ORIFICE	7.73	0	01:57			1.00
OPH05b	ORIFICE	10.68	0	01:57			1.00
OPH06a	ORIFICE	5.93	0	01:52			1.00
OPH06b	ORIFICE	9.03	0	01:52			1.00
OPH07	ORIFICE	10.26	0	01:42			1.00
OPH08	ORIFICE	8.88	0	01:52			1.00
OPH09	ORIFICE	17.37	0	02:02			1.00
OPH10	ORIFICE	18.26	0	02:00			1.00
OPH11	ORIFICE	4.89	0	02:02			1.00
W1	WEIR	0.00	0	00:00			0.00
OCB003	DUMMY	19.40	0	01:02			
OCB004	DUMMY	19.40	0	01:02			
OCB005	DUMMY	19.40	0	01:03			
OCB006	DUMMY	19.40	0	01:03			
OCB007	DUMMY	21.02	0	01:10			
OCB008	DUMMY	19.40	0	01:03			
OCB009	DUMMY	13.07	0	01:10			
OCB010	DUMMY	17.45	0	01:10			
OCB011	DUMMY	11.03	0	01:10			
OCB012	DUMMY	10.07	0	01:10			
OCB015	DUMMY	6.27	0	01:10			
OCB016	DUMMY	5.92	0	01:10			
OCB019	DUMMY	2.14	0	01:08			
OCB020	DUMMY	3.64	0	01:10			

Flow Classification Summary

--- Adjusted ----- Fraction of Time in Flow Class -----
--- /Actual Up Down Sub Sup Up Down Norm
Inlet
Conduit Length Dry Dry Dry Crit Crit Crit Crit Ltd
Ctrl

```

-----
----
101-MV          1.00  0.00  0.00  0.00  1.00  0.00  0.00  0.00  0.00
0.00
102-101        1.00  0.00  0.00  0.00  1.00  0.00  0.00  0.00  0.00
0.00
103-102        1.00  0.00  0.00  0.00  1.00  0.00  0.00  0.00  0.00
0.00
104-103        1.00  0.00  0.00  0.00  1.00  0.00  0.00  0.00  0.00
0.00
105-104        1.00  0.00  0.00  0.00  1.00  0.00  0.00  0.00  0.00
0.00
106-105        1.00  0.00  0.02  0.00  0.88  0.10  0.00  0.00  0.99
0.00
107-106        1.00  0.00  0.00  0.00  0.07  0.07  0.00  0.86  0.14
0.00
108-107        1.00  0.00  0.00  0.00  0.00  0.00  0.00  1.00  0.00
0.00
109-108        1.00  0.00  0.00  0.00  0.00  0.00  0.00  1.00  0.00
0.00
301-MV          1.00  0.00  0.00  0.00  1.00  0.00  0.00  0.00  0.00
0.00
302-301        1.00  0.00  0.00  0.00  1.00  0.00  0.00  0.00  0.00
0.00
303-302        1.00  0.00  0.00  0.00  1.00  0.00  0.00  0.00  0.00
0.00
304-303        1.00  0.00  0.00  0.00  1.00  0.00  0.00  0.00  0.00
0.00
305-304        1.00  0.00  0.00  0.00  1.00  0.00  0.00  0.00  0.00
0.00
306-305        1.00  0.00  0.00  0.00  1.00  0.00  0.00  0.00  0.00
0.00
307-306        1.00  0.00  0.00  0.00  1.00  0.00  0.00  0.00  0.00
0.00
308-307        1.00  0.00  0.00  0.00  1.00  0.00  0.00  0.00  0.00
0.00
309-308        1.00  0.00  0.00  0.00  1.00  0.00  0.00  0.00  0.00
0.00
310-309        1.00  0.00  0.00  0.00  1.00  0.00  0.00  0.00  0.00
0.00
311-310        1.00  0.00  0.77  0.00  0.23  0.00  0.00  0.00  0.99
0.00
C1              1.00  0.82  0.00  0.00  0.02  0.00  0.00  0.16  0.02
0.00
C10             1.00  0.83  0.17  0.00  0.00  0.00  0.00  0.00  0.00
0.00
C11             1.00  0.78  0.02  0.00  0.07  0.13  0.00  0.00  0.01
0.00
C12             1.00  0.79  0.03  0.00  0.05  0.12  0.00  0.00  0.99
0.00
C13             1.00  0.82  0.01  0.00  0.04  0.13  0.00  0.00  0.03
0.00
C14             1.00  0.00  0.81  0.00  0.19  0.00  0.00  0.00  0.99
0.00
C15             1.00  0.00  0.98  0.00  0.02  0.00  0.00  0.00  0.94
0.00
C16             1.00  0.00  0.00  0.00  1.00  0.00  0.00  0.00  0.00
0.00
C16_1           1.00  0.00  0.84  0.00  0.04  0.13  0.00  0.00  0.87
0.00

```

```

C16_2           1.00  0.00  0.00  0.00  1.00  0.00  0.00  0.00  1.00
0.00
C17             1.00  0.00  0.98  0.00  0.02  0.00  0.00  0.00  0.93
0.00
C18             1.00  0.00  0.00  0.00  0.84  0.16  0.00  0.00  0.83
0.00
C19             1.00  0.86  0.14  0.00  0.00  0.00  0.00  0.00  0.00
0.00
C2              1.00  0.82  0.18  0.00  0.00  0.00  0.00  0.00  0.00
0.00
C20             1.00  0.98  0.00  0.00  0.02  0.00  0.00  0.00  0.00
0.00
C20_1           1.00  0.00  0.82  0.00  0.07  0.11  0.00  0.00  0.94
0.00
C20_2           1.00  0.00  0.00  0.00  0.03  0.00  0.00  0.97  0.03
0.00
C21             1.00  0.86  0.00  0.00  0.02  0.00  0.00  0.12  0.02
0.00
C22             1.00  0.97  0.03  0.00  0.00  0.00  0.00  0.00  0.00
0.00
C23             1.00  0.98  0.02  0.00  0.00  0.00  0.00  0.00  0.00
0.00
C24             1.00  0.83  0.17  0.00  0.00  0.00  0.00  0.00  0.00
0.00
C25             1.00  0.83  0.17  0.00  0.00  0.00  0.00  0.00  0.00
0.00
C26             1.00  0.98  0.00  0.00  0.01  0.00  0.00  0.00  0.00
0.00
C26_1           1.00  0.00  0.83  0.00  0.14  0.03  0.00  0.00  0.97
0.00
C26_2           1.00  0.00  0.00  0.00  1.00  0.00  0.00  0.00  1.00
0.00
C27             1.00  0.00  0.83  0.00  0.17  0.00  0.00  0.00  0.99
0.00
C28             1.00  0.00  0.00  0.00  1.00  0.00  0.00  0.00  0.00
0.00
C29             1.00  0.00  0.00  0.00  1.00  0.00  0.00  0.00  0.00
0.00
C3              1.00  0.81  0.19  0.00  0.00  0.00  0.00  0.00  0.00
0.00
C30             1.00  0.00  0.00  0.00  1.00  0.00  0.00  0.00  0.00
0.00
C31             1.00  0.00  0.00  0.00  1.00  0.00  0.00  0.00  0.00
0.00
C32             1.00  0.00  0.00  0.00  1.00  0.00  0.00  0.00  0.00
0.00
C4              1.00  0.79  0.03  0.00  0.13  0.04  0.00  0.00  0.99
0.00
C5              1.00  0.75  0.05  0.00  0.07  0.12  0.00  0.00  0.99
0.00
C6              1.00  0.78  0.03  0.00  0.06  0.13  0.00  0.00  0.99
0.00
C7              1.00  0.98  0.02  0.00  0.00  0.00  0.00  0.00  0.00
0.00
C7_1           1.00  0.00  0.77  0.00  0.11  0.11  0.00  0.00  0.99
0.00
C7_2           1.00  0.00  0.00  0.00  0.83  0.17  0.00  0.00  0.01
0.00
C8              1.00  0.76  0.01  0.00  0.10  0.13  0.00  0.00  0.01
0.00

```



```

C9          1.00  0.00  0.77  0.00  0.18  0.06  0.00  0.00  0.99
0.00
ParkSwale   1.00  0.00  0.00  0.00  0.00  0.00  0.00  1.00  0.00
0.00
STM-206_(STM) 1.00  0.00  0.00  0.00  1.00  0.00  0.00  0.00  0.00
0.00
STM-211_(1)_(STM) 1.00  0.00  0.00  0.00  1.00  0.00  0.00  0.00  0.05
0.00
STM-211_(STM) 1.00  0.00  0.01  0.00  0.96  0.03  0.00  0.00  1.00
0.00
STM-263_(STM) 1.00  0.00  0.00  0.00  1.00  0.00  0.00  0.00  0.00
0.00
STM-264_(STM) 1.00  0.00  0.00  0.00  1.00  0.00  0.00  0.00  0.00
0.00
    
```

 Conduit Surcharge Summary

Conduit	Hours Full			Hours	Hours
	Both Ends	Upstream	Dnstream	Above Full Normal Flow	Capacity Limited
101-MV	24.00	24.00	24.00	0.01	0.06
102-101	24.00	24.00	24.00	0.01	0.01
103-102	24.00	24.00	24.00	0.01	0.01
104-103	24.00	24.00	24.00	0.08	0.08
105-104	0.18	0.18	24.00	0.01	0.01
106-105	0.02	0.02	0.18	0.01	0.01
107-106	0.01	0.01	0.01	0.01	0.01
301-MV	24.00	24.00	24.00	0.01	0.01
302-301	24.00	24.00	24.00	0.58	0.59
303-302	24.00	24.00	24.00	0.01	0.01
304-303	24.00	24.00	24.00	0.01	0.01
305-304	24.00	24.00	24.00	0.01	0.01
306-305	24.00	24.00	24.00	0.01	0.01
307-306	24.00	24.00	24.00	0.01	0.01
308-307	24.00	24.00	24.00	0.01	0.01
309-308	24.00	24.00	24.00	0.01	0.01
310-309	24.00	24.00	24.00	0.01	0.01
311-310	0.01	0.01	23.83	0.01	0.01
C16	0.01	0.01	24.00	0.01	0.01
STM-206_(STM)	24.00	24.00	24.00	0.01	0.01
STM-263_(STM)	24.00	24.00	24.00	0.01	0.01
STM-264_(STM)	24.00	24.00	24.00	0.01	0.01

Analysis begun on: Wed Jul 31 11:42:14 2024
 Analysis ended on: Wed Jul 31 11:42:18 2024
 Total elapsed time: 00:00:04



- LEGEND**
- PROPERTY LINE
 - PROPOSED CURB
 - DC — PROPOSED DEPRESSED CURB
 - FC — PROPOSED FLUSH CURB
 - PROPOSED RETAINING WALL CW GUARD RAIL
 - ▭ PROPOSED WALKWAY
 - ▨ TERRACING 3:1 SLOPE MAX (UNLESS OTHERWISE INDICATED)
 - SURFACE PONDING EXTENTS
 - PROPOSED CAP
 - PROPOSED SANITARY SERVICE
 - PROPOSED STORM SEWER
 - PROPOSED CATCHBASIN MANHOLE
 - PROPOSED CATCHBASIN
 - ▣ PROPOSED LANDSCAPE DRAIN
 - ▣ PROPOSED AREA DRAIN

- PROPOSED TRENCH DRAIN
- PROPOSED SIAMISE CONNECTION
- PROPOSED HYDRANT & VALVE
- PROPOSED VALVE AND VALVE BOX
- PROPOSED BUILDING ENTRANCE
- BOREHOLE LOCATION (REFER TO GEOTECH REPORT)
- EXISTING UTILITY POLE CW GUY WIRES
- EXISTING VALVE & VALVE CHAMBER
- EXISTING HYDRANT CW VALVE
- EXISTING SANITARY MANHOLE
- EXISTING STORM MANHOLE
- EXISTING CATCHBASIN
- EXISTING STREETLIGHT
- EXISTING PARKING LOT SIGNAGE

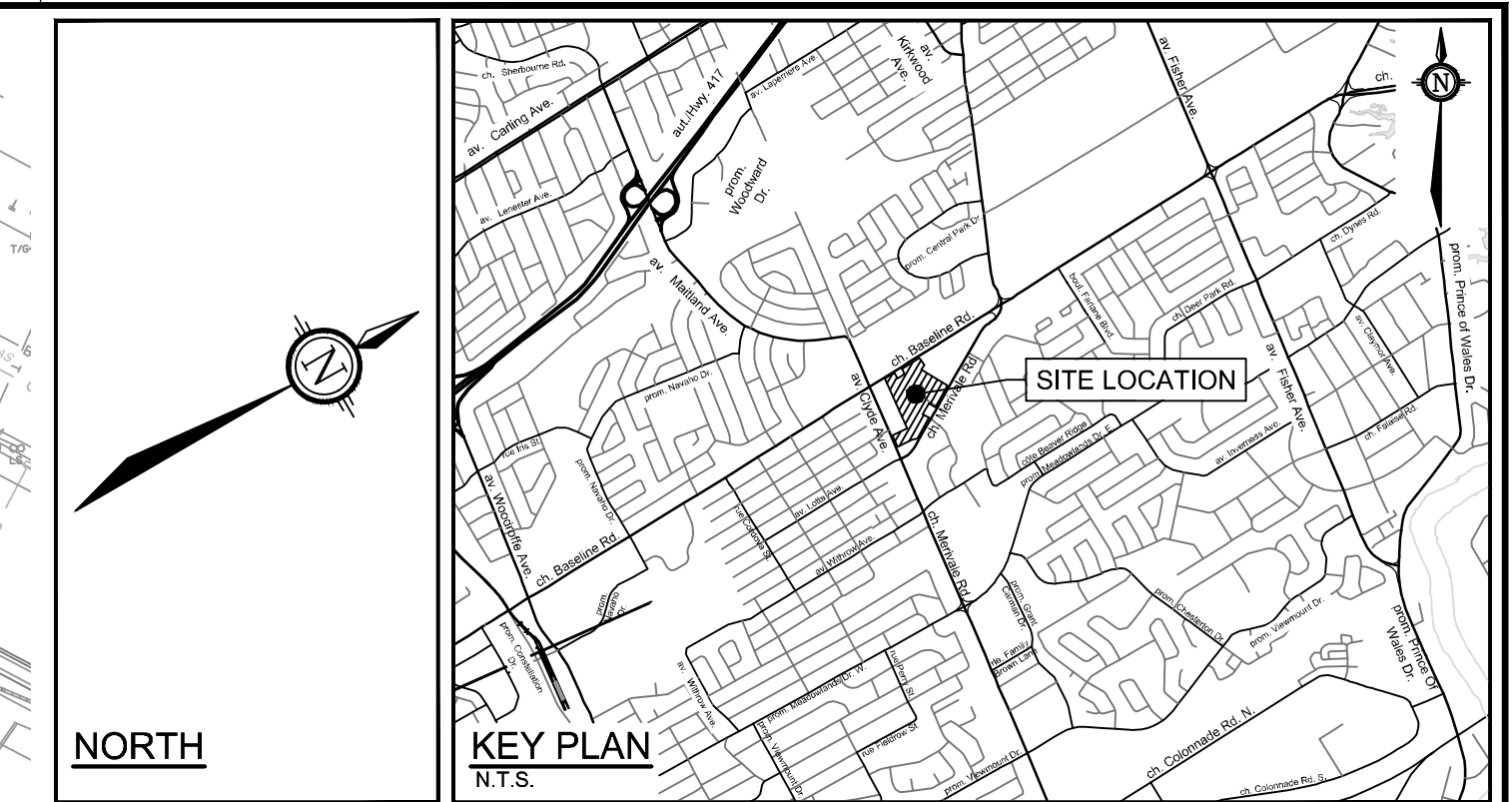

NOTE:
 THE POSITION OF ALL POLE LINES, CONDUITS, WATERMANS, SEWERS AND OTHER UNDERGROUND AND OVERGROUND UTILITIES AND STRUCTURES IS NOT NECESSARILY SHOWN ON THE CONTRACT DRAWINGS, AND WHERE SHOWN, THE ACCURACY OF THE POSITION OF SUCH UTILITIES AND STRUCTURES IS NOT GUARANTEED. BEFORE STARTING WORK, DETERMINE THE EXACT LOCATION OF ALL SUCH UTILITIES AND STRUCTURES AND ASSUME ALL LIABILITY FOR DAMAGE TO THEM.

REFER TO 121009-NDGR FOR ADDITIONAL NOTES & DETAILS

SCALE 1:500 		FOR REVIEW ONLY ARM GJM C.J.F./ARM ARM GJM		LOCATION CITY or TOWNSHIP NAME OF DEVELOPMENT DRAWING NAME PONDING PLAN		PROJECT No. 121009
1. UPDATED PER CITY COMMENTS No. REVISION		AUG 1/2024 DATE BY		Telephone (613) 254-9643 Facsimile (613) 254-5867 Website www.novatech-eng.com		REV # 1 121009-PND

C:\Users\121009\OneDrive\Documents\121009-ponding\121009-ponding.dwg PND, Aug 01, 2024, 9:41 am, emashap

TABLE 5A: Post-Development Runoff Coefficient "C" - Phase 1

Area	0.4	Ha	5 Year Event		100 Year Event	
			"C"	C _{avg}	"C" + 25%	*C _{avg}
Total	Hard	0.117	0.90	0.85	1.00	0.95
0.287	Roof	0.151	0.90		1.00	
	Soft	0.019	0.20		0.25	

* Remainder assumed hard due to
 * Roof area based on building foot
 * Soft area based on parkland det

TABLE 5B: 2 YEAR EVENT QUANTITY STORAGE REQUIREMENT - Phase 1

0.287 =Area (ha)
 0.85 = C

Return Period	Time (min)	Intensity (mm/hr)	Flow Q (L/s)	Allowable Runoff (L/s)	Net Flow to be Stored (L/s)	Storage Req'd (m ³)
2 YEAR	15	61.77	42.03	10.0	32.03	28.83
	20	52.03	35.41	10.0	25.41	30.49
	25	45.17	30.74	10.0	20.74	31.11
	30	40.04	27.25	10.0	17.25	31.05
	35	36.06	24.54	10.0	14.54	30.53

TABLE 5C: 5 YEAR EVENT QUANTITY STORAGE REQUIREMENT - Phase 1

0.287 =Area (ha)
 0.85 = C

Return Period	Time (min)	Intensity (mm/hr)	Flow Q (L/s)	Allowable Runoff (L/s)	Net Flow to be Stored (L/s)	Storage Req'd (m ³)
5 YEAR	25	60.90	41.44	10.0	31.44	47.16
	30	53.93	36.70	10.0	26.70	48.06
	35	48.52	33.02	10.0	23.02	48.34
	40	44.18	30.07	10.0	20.07	48.16
	45	40.63	27.65	10.0	17.65	47.65

TABLE 5D: 100 YEAR EVENT QUANTITY STORAGE REQUIREMENT - Phase 1

0.287 =Area (ha)
 0.95 = C

Return Period	Time (min)	Intensity (mm/hr)	Flow Q (L/s)	Allowable Runoff (L/s)	Net Flow to be Stored (L/s)	Storage Req'd (m ³)
100 YEAR	55	59.62	45.17	10.0	35.17	116.06
	60	55.89	42.35	10.0	32.35	116.44
	65	52.65	39.88	10.0	29.88	116.55
	70	49.79	37.72	10.0	27.72	116.43
	75	47.26	35.80	10.0	25.80	116.10

TABLE 5E: 100+20 YEAR EVENT QUANTITY STORAGE REQUIREMENT - Phase 1

0.287 =Area (ha)
 0.95 = C

Return Period	Time (min)	Intensity (mm/hr)	Flow Q (L/s)	Allowable Runoff (L/s)	Net Flow to be Stored (L/s)	Storage Req'd (m ³)
100 YEAR +20%	70	59.75	45.26	10.0	35.26	148.11
	75	56.71	42.96	10.0	32.96	148.32
	80	53.99	40.90	10.0	30.90	148.33
	85	51.54	39.05	10.0	29.05	148.16
	90	49.33	37.37	10.0	27.37	147.82

Equations:

Flow Equation

$$Q = 2.78 \times C \times I \times A$$

Where:

C is the runoff coefficient

I is the rainfall intensity, City of Ottawa IDF

A is the total drainage area

Runoff Coefficient Equation

$$C_s = (A_{\text{hard}} \times 0.9 + A_{\text{soft}} \times 0.2) / A_{\text{Tot}}$$

$$C_{100} = (A_{\text{hard}} \times 1.0 + A_{\text{soft}} \times 0.25) / A_{\text{Tot}}$$

TABLE 5F: Structure information - Phase 1

Structures	Size Dia.(mm)	Area (m ²)	T/G	Inv IN	Inv OUT
STORAGE TANK	N/A	48.59	90.30	N/A	n/a

TABLE 5G: Storage Provided - Phase 1

Area A-2: Storage Table				
Elevation (m)	System Depth (m)	TANK Volume (m ³)	Underground Volume (m ³)*	
90.350	0.00	0.00	0.00	
90.450	0.10	4.86	4.86	
90.550	0.20	9.72	9.72	
90.650	0.30	14.58	14.58	
90.750	0.40	19.44	19.44	
90.850	0.50	24.29	24.29	
90.950	0.60	29.15	29.15	
91.050	0.70	34.01	34.01	
91.150	0.80	38.87	38.87	
91.250	0.90	43.73	43.73	
91.350	1.00	48.59	48.59	
91.450	1.10	53.45	53.45	
91.550	1.20	58.31	58.31	
91.650	1.30	63.17	63.17	
91.750	1.40	68.03	68.03	
91.850	1.50	72.88	72.88	
91.950	1.60	77.74	77.74	
92.050	1.70	82.60	82.60	
92.150	1.80	87.46	87.46	
92.250	1.90	92.32	92.32	
92.350	2.00	97.18	97.18	
92.450	2.10	102.04	102.04	
92.550	2.20	106.90	106.90	
92.650	2.30	111.76	111.76	
92.750	2.40	116.62	116.62	
92.850	2.50	121.47	121.47	
92.950	2.60	126.33	126.33	
93.050	2.70	131.19	131.19	
93.150	2.80	136.05	136.05	
93.250	2.90	140.91	140.91	
93.350	3.00	145.77	145.77	
93.450	3.10	150.63	150.63	
93.550	3.20	155.49	155.49	
93.650	3.30	160.35	160.35	Top of tank
93.750	3.40	160.46	160.46	
93.800	3.45	160.52	160.52	
93.900	3.55	160.63	160.63	
94.000	3.65	160.74	160.74	
94.100	3.75	160.86	160.86	
94.200	3.85	160.97	160.97	
94.300	3.95	161.08	161.08	Proposed Lid elevation

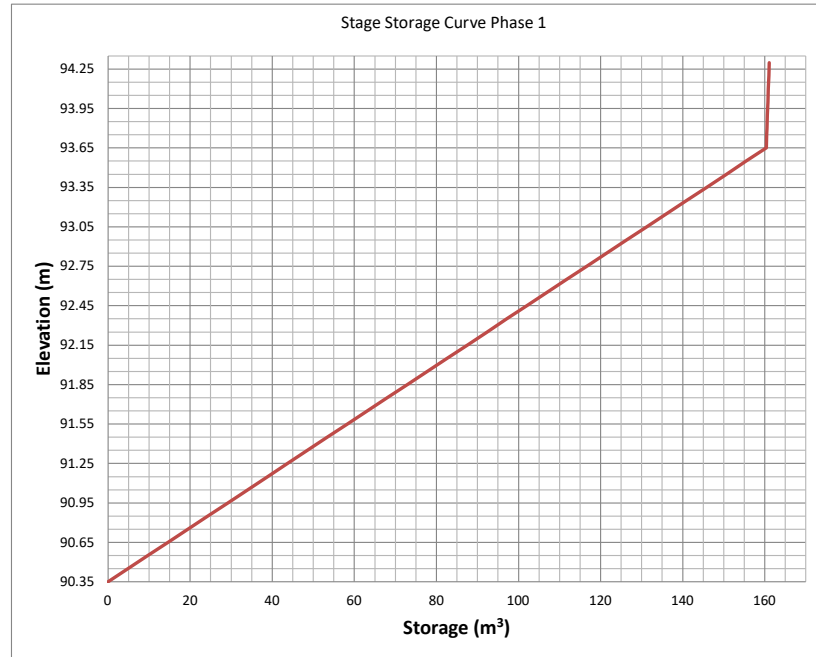

TABLE 5H: Orifice Sizing information- Phase 1

Design Event	PUMP			Outlet dia. (mm)	Required Volume (m ³)
	Flow (L/S)	Depth (m)	Elev (m)		
1:2 Year	10.0	0.64	90.99	250.00	31.11
1:5 Year	10.0	0.99	91.34	250.00	48.34
1:100 Year	10.0	2.40	92.75	250.00	116.55
1:100+20% Year	10.0	3.05	93.40	200.00	148.33

1500 Merivale
Design Storm Time Series Data
3-hour Chicago Design Storms



C25mm-3.stm		C2-3.stm		C5-3.stm	
Duration	Intensity	Duration	Intensity	Duration	Intensity
min	mm/hr	min	mm/hr	min	mm/hr
0:00	0	0:00	0	0:00	0
0:10	2.21	0:10	2.81	0:10	3.68
0:20	2.75	0:20	3.5	0:20	4.58
0:30	3.68	0:30	4.69	0:30	6.15
0:40	5.73	0:40	7.3	0:40	9.61
0:50	14.29	0:50	18.21	0:50	24.17
1:00	60.28	1:00	76.81	1:00	104.19
1:10	18.9	1:10	24.08	1:10	32.04
1:20	9.7	1:20	12.36	1:20	16.34
1:30	6.53	1:30	8.32	1:30	10.96
1:40	4.94	1:40	6.3	1:40	8.29
1:50	3.99	1:50	5.09	1:50	6.69
2:00	3.37	2:00	4.29	2:00	5.63
2:10	2.92	2:10	3.72	2:10	4.87
2:20	2.58	2:20	3.29	2:20	4.3
2:30	2.32	2:30	2.95	2:30	3.86
2:40	2.1	2:40	2.68	2:40	3.51
2:50	1.93	2:50	2.46	2:50	3.22
3:00	1.79	3:00	2.28	3:00	2.98

1500 Merivale
Design Storm Time Series Data
3-hour Chicago Design Storms



C100-3.stm		C100-3+20%.stm	
Duration	Intensity	Duration	Intensity
min	mm/hr	min	mm/hr
0:00	0	0:00	0
0:10	6.05	0:10	6.14
0:20	7.54	0:20	9.05
0:30	10.16	0:30	12.19
0:40	15.97	0:40	19.16
0:50	40.65	0:50	48.78
1:00	178.56	1:00	214.27
1:10	54.05	1:10	64.86
1:20	27.32	1:20	32.78
1:30	18.24	1:30	21.89
1:40	13.74	1:40	16.49
1:50	11.06	1:50	13.27
2:00	9.29	2:00	11.15
2:10	8.02	2:10	9.62
2:20	7.08	2:20	8.5
2:30	6.35	2:30	7.62
2:40	5.76	2:40	6.91
2:50	5.28	2:50	6.34
3:00	4.88	3:00	5.86

1500 Merivale
Design Storm Time Series Data
4-hour Chicago Design Storms

C25mm-4.stm

Duration	Intensity
min	mm/hr
0:00	0
0:10	1.51
0:20	1.75
0:30	2.07
0:40	2.58
0:50	3.46
1:00	5.39
1:10	13.44
1:20	56.67
1:30	17.77
1:40	9.12
1:50	6.14
2:00	4.65
2:10	3.76
2:20	3.17
2:30	2.74
2:40	2.43
2:50	2.18
3:00	1.98
3:10	1.81
3:20	1.68
3:30	1.56
3:40	1.47
3:50	1.38
4:00	1.31

1500 Merivale

Roadway Cross-Sections

7.0m Roadway (Left) - No Parking

0	0.35
5	0.16
5.99	0.15
6	0
9.5	0.1

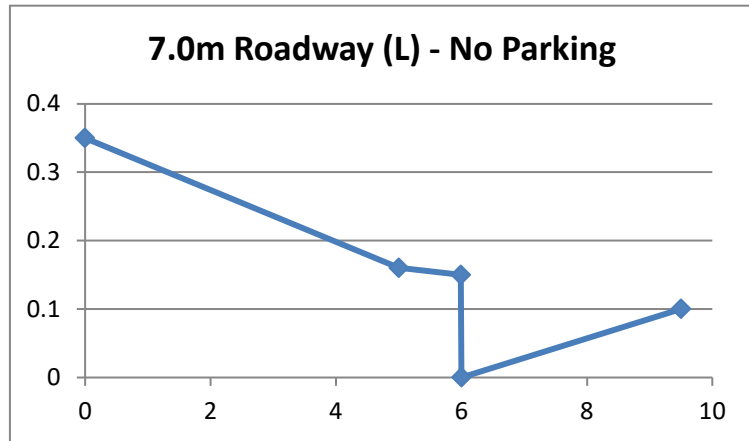

7.0m Roadway (Right) - No Parking

0	0.1
3.5	0
3.51	0.15
4.5	0.16
9.5	0.35

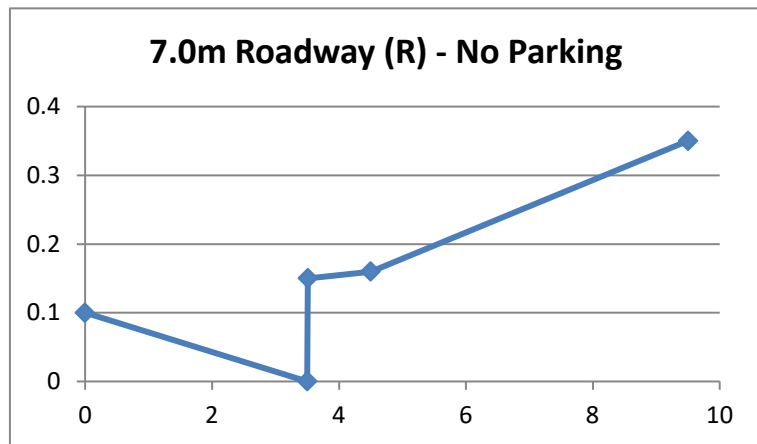

7.0m Roadway (Left) - No Parking

0	0.35
5	0.21
5.99	0.2
6	0.05
8.5	0
12	0.1

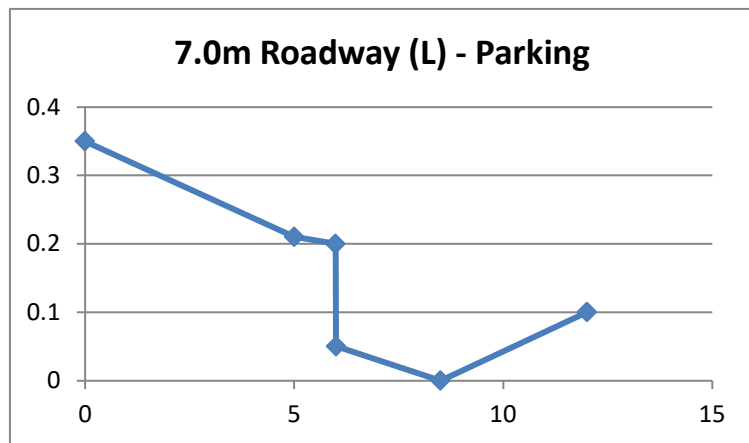

1500 Merivale

Roadway Cross-Sections

7.0m Roadway (Right) - No Parking

0	0.1
3.5	0
6	0.05
6.01	0.2
7	0.21
12	0.35

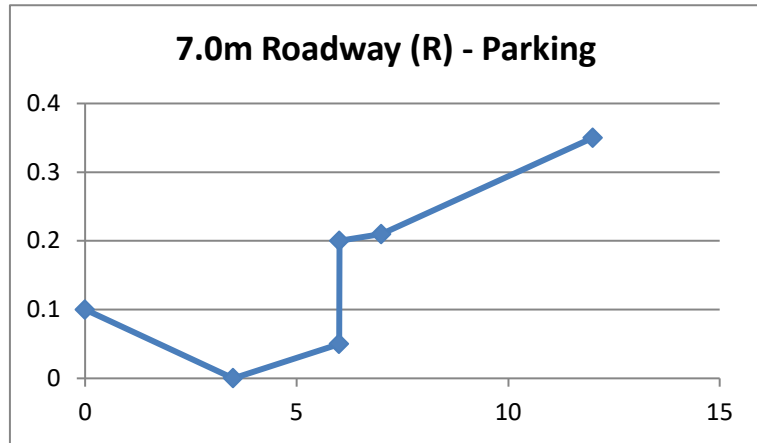

DRAWING NOT TO BE USED FOR CONSTRUCTION

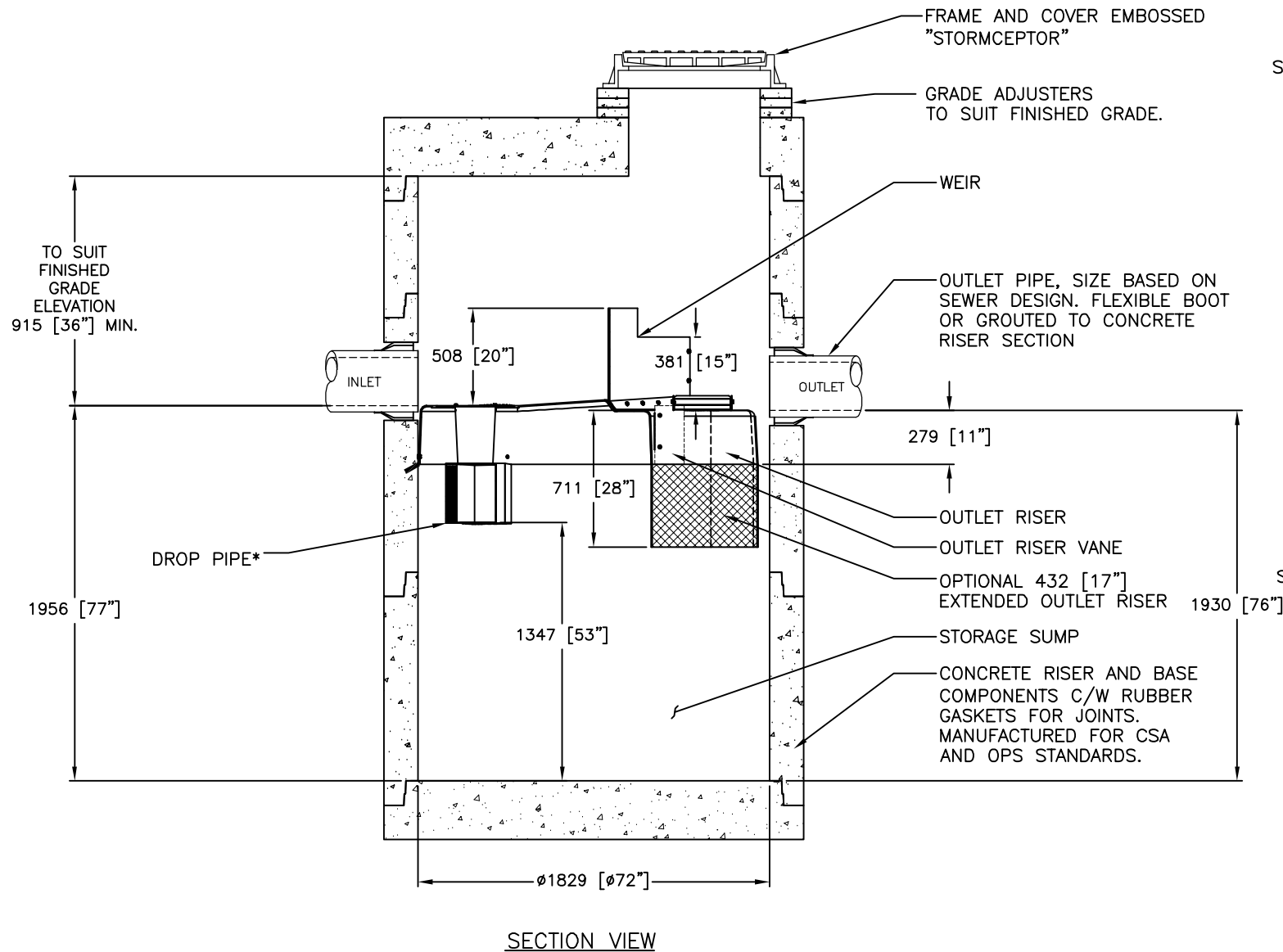

SECTION VIEW

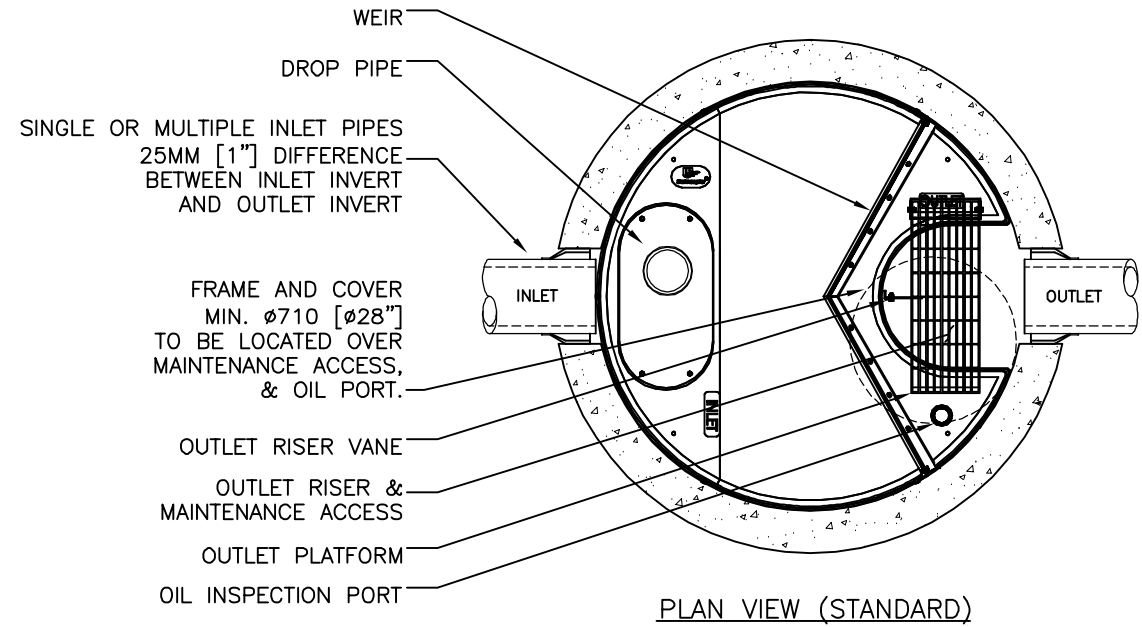

PLAN VIEW (STANDARD)

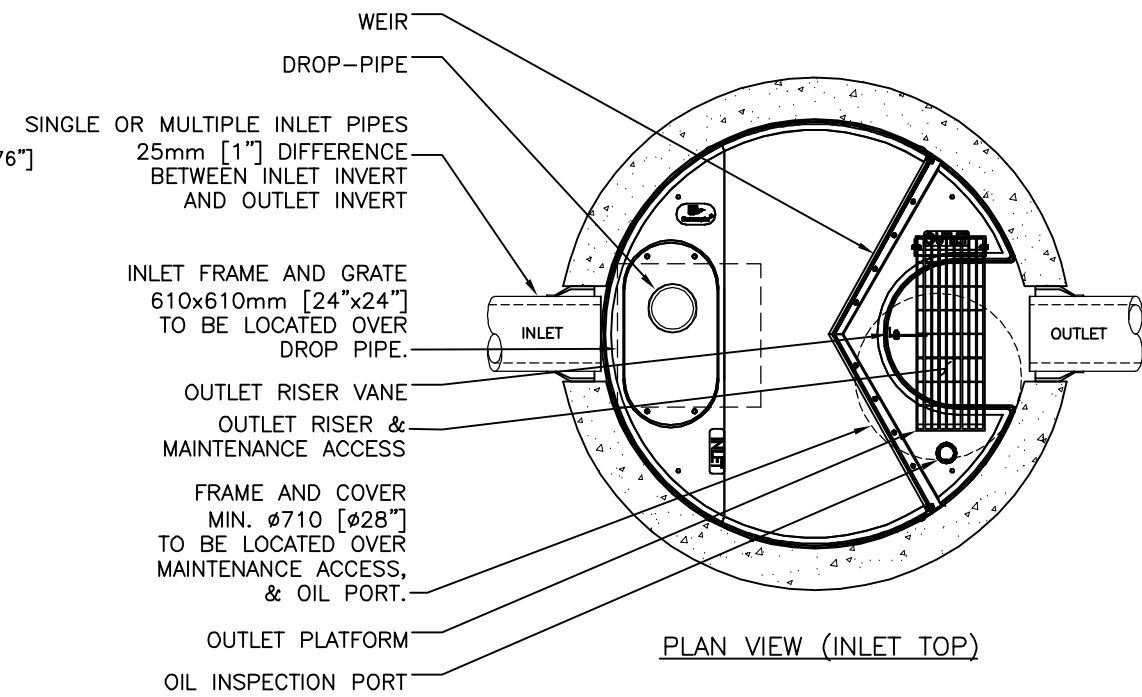

PLAN VIEW (INLET TOP)

GENERAL NOTES:

- * MAXIMUM SURFACE LOADING RATE (SLR) INTO LOWER CHAMBER THROUGH DROP PIPE IS 1135 L/min/m² (27.9 gpm/ft²) FOR STORMCEPTOR EF6 AND 535 L/min/m² (13.1 gpm/ft²) FOR STORMCEPTOR EFO6 (OIL CAPTURE CONFIGURATION).
- 1. ALL DIMENSIONS INDICATED ARE IN MILLIMETERS (INCHES) UNLESS OTHERWISE SPECIFIED.
- 2. STORMCEPTOR STRUCTURE INLET AND OUTLET PIPE SIZE AND ORIENTATION SHOWN FOR INFORMATIONAL PURPOSES ONLY.
- 3. UNLESS OTHERWISE NOTED, BYPASS INFRASTRUCTURE, SUCH AS ALL UPSTREAM DIVERSION STRUCTURES, CONNECTING STRUCTURES, OR PIPE CONDUITS CONNECTING TO COMPLETE THE STORMCEPTOR SYSTEM SHALL BE PROVIDED AND ADDRESSED SEPARATELY.
- 4. DRAWING FOR INFORMATION PURPOSES ONLY. REFER TO ENGINEER'S SITE/UTILITY PLAN FOR STRUCTURE ORIENTATION.
- 5. NO PRODUCT SUBSTITUTIONS SHALL BE ACCEPTED UNLESS SUBMITTED 10 DAYS PRIOR TO PROJECT BID DATE, OR AS DIRECTED BY THE ENGINEER OF RECORD.

INSTALLATION NOTES

- A. ANY SUB-BASE, BACKFILL DEPTH, AND/OR ANTI-FLOTATION PROVISIONS ARE SITE-SPECIFIC DESIGN CONSIDERATIONS AND SHALL BE SPECIFIED BY ENGINEER OF RECORD.
- B. CONTRACTOR TO PROVIDE EQUIPMENT WITH SUFFICIENT LIFTING AND REACH CAPACITY TO LIFT AND SET THE STRUCTURE (LIFTING CLUTCHES PROVIDED)
- C. CONTRACTOR WILL INSTALL AND LEVEL THE STRUCTURE, SEALING THE JOINTS, LINE ENTRY AND EXIT POINTS (NON-SHRINK GROUT WITH APPROVED WATERSTOP OR FLEXIBLE BOOT)
- D. CONTRACTOR TO TAKE APPROPRIATE MEASURES TO PROTECT THE DEVICE FROM CONSTRUCTION-RELATED EROSION RUNOFF.
- E. DEVICE ACTIVATION, BY CONTRACTOR, SHALL OCCUR ONLY AFTER SITE HAS BEEN STABILIZED AND THE STORMCEPTOR UNIT IS CLEAN AND FREE OF DEBRIS.

FOR SITE SPECIFIC DRAWINGS PLEASE CONTACT YOUR LOCAL STORMCEPTOR REPRESENTATIVE. SITE SPECIFIC DRAWINGS ARE BASED ON THE BEST AVAILABLE INFORMATION AT THE TIME. SOME FIELD REVISIONS TO THE SYSTEM LOCATION OR CONNECTION PIPING MAY BE NECESSARY BASED ON AVAILABLE SPACE OR SITE CONFIGURATION REVISIONS. ELEVATIONS SHOULD BE MAINTAINED EXCEPT WHERE NOTED ON BYPASS STRUCTURE (IF REQUIRED).

STANDARD DETAIL NOT FOR CONSTRUCTION

SITE SPECIFIC DATA REQUIREMENTS					
STORMCEPTOR MODEL	EFO6				
STRUCTURE ID	*				
HYDROCARBON STORAGE REQ'D (L)	*				
WATER QUALITY FLOW RATE (L/s)	*				
PEAK FLOW RATE (L/s)	*				
RETURN PERIOD OF PEAK FLOW (yrs)	*				
DRAINAGE AREA (HA)	*				
DRAINAGE AREA IMPERVIOUSNESS (%)	*				
PIPE DATA:	I.E.	MAT'L	DIA	SLOPE %	HGL
INLET #1	*	*	*	*	*
INLET #2	*	*	*	*	*
OUTLET	*	*	*	*	*
* PER ENGINEER OF RECORD					

This drawing and information shown on this drawing is provided as a service to the project owner, engineer and contractor by Imbrium Systems ("Imbrium"). Neither the drawing, nor any part thereof, may be reproduced, stored in a retrieval system, or transmitted in any form or by any means, electronic, mechanical, photocopying, recording, or by any information storage and retrieval system, without the prior written consent of Imbrium. It is to be used only for the project and site for which it is prepared and Imbrium expressly disclaims any liability or responsibility for such use. If discrepancies between the supplied information upon which this drawing is based and actual field conditions are discovered, the contractor shall be responsible for re-evaluation of the design. Imbrium accepts no liability for designs based on missing, incomplete or inaccurate information supplied by others.

MARK	DATE	REVISION DESCRIPTION	BY
###	###/###/###	OUTLET PLATFORM	JSK
###	###/###/###	INITIAL RELEASE	JSK

407 FAIRVIEW DRIVE, WHITBY, ON L1N 3J8
 TEL: 800-585-4801 CA 416-960-9800 INTL +1-416-960-9800
 THE ENGINEER OF RECORD IS RESPONSIBLE FOR THE ACCURACY OF THE INFORMATION PROVIDED ON THIS DRAWING. THE CONTRACTOR SHALL VERIFY ALL DIMENSIONS AND CONDITIONS AT THE TIME OF CONSTRUCTION. IMBRIUM SYSTEMS SHALL NOT BE RESPONSIBLE FOR ANY ERRORS OR OMISSIONS ON THIS DRAWING.

DATE:	10/13/2017		
DESIGNED:	JSK	DRAWN:	JSK
CHECKED:	BSF	APPROVED:	SP
PROJECT No.:	EFO6	SEQUENCE No.:	*
SHEET:	1 OF 1		

1500 Merivale
HGL Elevations

Manhole ID	MH Invert Elevation (m)	T/G Elevation (m)	HGL Elevation - 100yr4hr (m)	HGL Elevation - 100yr4hr+20% (m)	Clearance from T/G (100yr) (m)	Clearance from T/G (100yr+20%) (m)
MH101	92.23	94.06	94.09	94.11	-0.03	-0.05
MH102	92.27	94.08	94.10	94.12	-0.02	-0.04
MH103	92.42	94.06	94.14	94.18	-0.08	-0.12
MH104	92.58	94.68	94.26	94.35	0.42	0.33
MH105	93.88	96.56	94.55	94.69	2.01	1.87
MH106	94.35	97.17	94.65	94.81	2.52	2.36
MH107	94.88	97.97	95.04	95.07	2.93	2.90
MH108	95.89	98.59	96.01	96.02	2.58	2.58
MH109	98.63	101.56	98.70	98.71	2.86	2.85
MH301	92.62	94.56	94.75	94.75	-0.19	-0.19
MH302	92.70	94.55	94.75	94.75	-0.20	-0.20
MH303	92.75	94.49	94.75	94.75	-0.26	-0.26
MH304	92.80	94.52	94.75	94.76	-0.23	-0.23
MH305	92.89	94.58	94.76	94.76	-0.17	-0.18
MH306	93.01	95.06	94.77	94.78	0.29	0.28
MH307	93.07	95.70	94.79	94.79	0.91	0.91
MH308	93.33	95.87	94.85	94.86	1.02	1.01
MH309	93.74	96.27	94.87	94.89	1.40	1.38
MH310	94.02	96.50	94.89	94.91	1.61	1.59
MH311	94.89	97.19	94.93	94.94	2.26	2.25

1500 Merivale

Inlet Control Device Parameters



Engineers, Planners & Landscape Architects

Structure	Diameter (mm)	Max. Head (2yr) (m)	Calculated 2yr Capture Rate (L/s)	Model Results*			
				2yr Approach Flow (L/s)	2yr Capture Rate (L/s)	100yr Approach Flow (L/s)	100yr Capture Rate (L/s)
CB01	152	1.22	55.1	18.9	18.8	109.2	8.7
CB02	178	1.11	72.0	19.6	19.5	100.1	12.1
CB03	83	1.17	16.1	14.1	9.3	46.5	19.4
CB04	83	1.17	16.1	18.4	11.1	70.8	19.4
CB05	83	1.42	17.7	16.5	9.3	45.4	19.4
CB06	83	1.42	17.7	16.3	9.2	57.9	19.4
CB07	102	1.15	24.1	30.2	10.7	75.8	21.0
CB08	83	1.16	16.0	17.7	9.1	55.3	19.4
CB09	83	1.16	16.0	20.3	6.7	48.5	13.1
CB10	83	1.16	16.0	14.2	7.4	41.3	17.5
CB11	83	1.16	16.0	9.0	5.3	20.8	11.0
CB12	83	1.16	16.0	6.5	4.0	18.7	10.1
CB13	152	1.12	52.8	21.8	21.7	73.0	0.0**
CB14	83	1.16	16.0	10.5	10.3	66.3	0.0**
CB15	83	1.16	16.0	5.7	2.8	14.2	6.3
CB16	83	1.16	16.0	3.8	2.7	8.9	5.9
CB17	102	1.75	29.7	27.7	27.3	67.9	22.5
CB18	83	1.76	19.7	8.4	8.1	64.0	14.9
CB19	83	1.16	16.0	10.7	0.8	28.9	2.1
CB20	83	1.16	16.0	1.6	1.1	5.2	3.6
CB21	127	1.19	37.9	36.0	35.6	90.2	40.4

*From PCSWMM Model, 2-year & 100-year 3-hour Chicago storm distribution

**Downstream HGL boundary condition is higher than T/G for these CBs, so no inflow occurs

1500 Merivale ICD Rating Curves

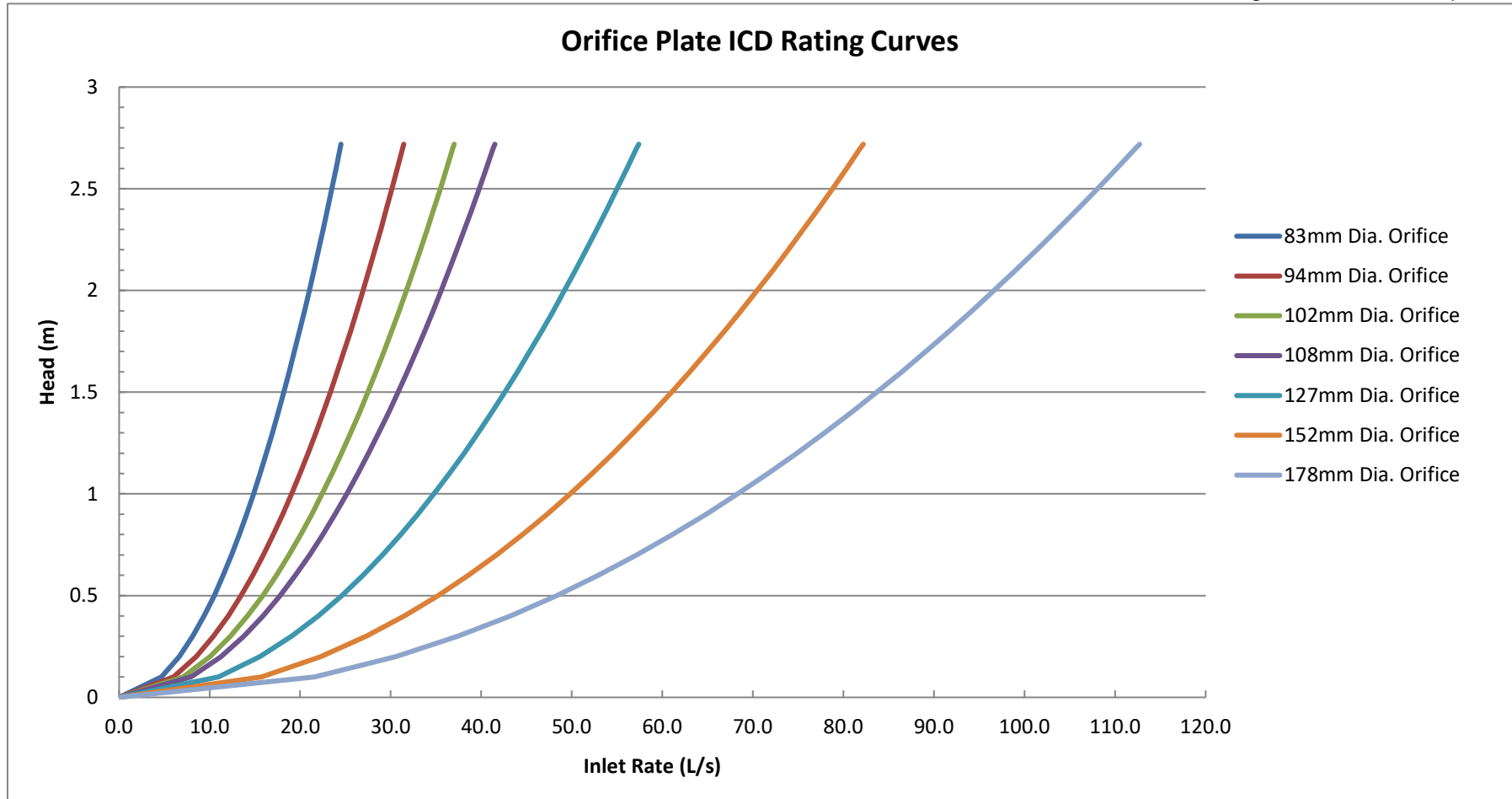

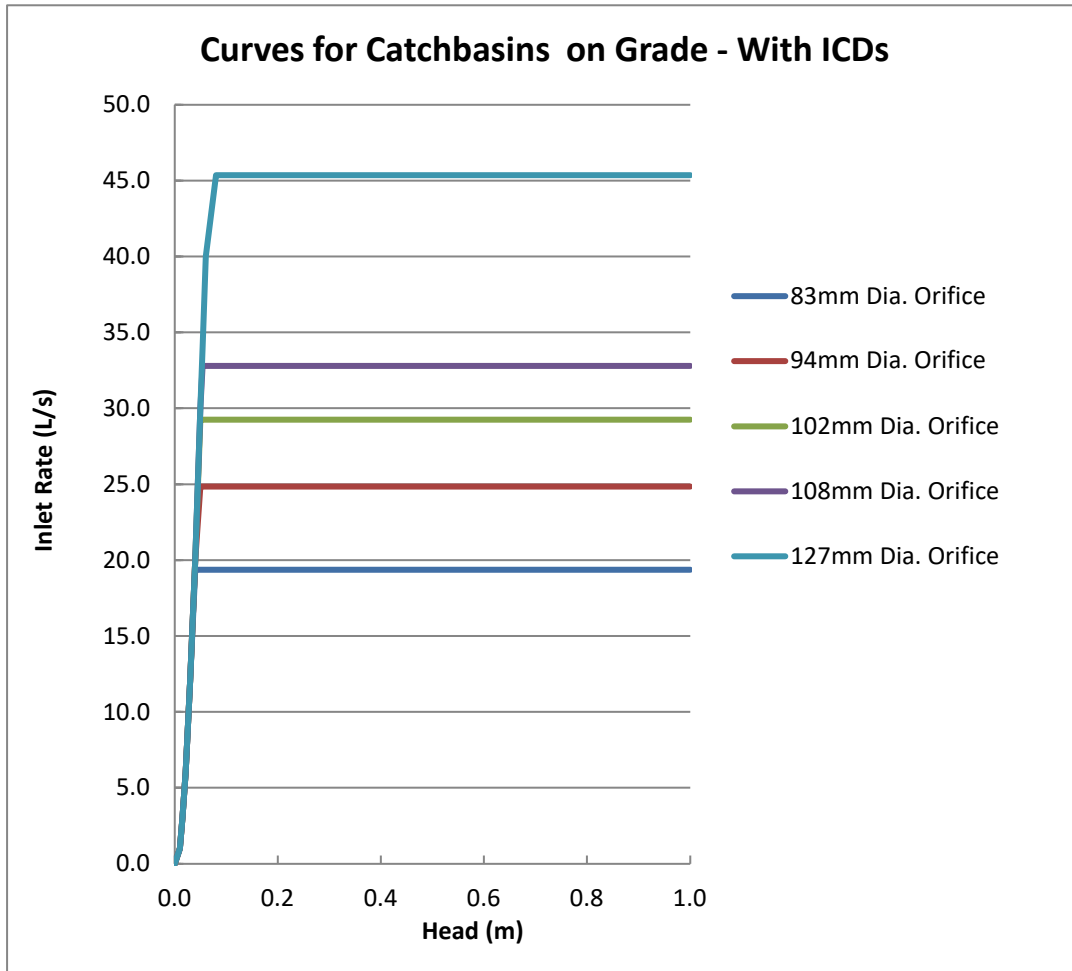

Curb Inlet Catchbasins on Continuous Grade

Depth vs. Captured Flow Curve

A standard depth vs. captured flow curve for catch basins on a continuous grade was provided to Novatech by City staff for use in a dual-drainage model of an existing residential neighbourhood. This standard curve was derived using the inlet curves in Appendix 7A of the Ottawa Sewer Design Guidelines.

Novatech reviewed the methodology used to create this standard curve (described below) and determined that it was suitable for general use in other dual-drainage models.

- MTO Design Chart 4.04 provides the relationship between the gutter flow rate (Q_g) and flow spread (T) for Barrier Curb.
- MTO Design Chart 4.12 provides the relationship between flow spread (T) and flow depth (D).
- The relationship between the gutter flow rate (Q_g) and flow depth (D) was determined for different road slopes using the above charts and Manning's equation (refer to pages 58-60 of the MTO Drainage Management Manual – Part 2);
- The relationship between approach flow (Q_a) and captured flow (Q_c) was determined for different road slopes using the design chart for Barrier Curb with Gutter (Appendix 7-A.2).
- Using the above information, a family of curves was developed to characterize the relationship between flow depth and captured flow for curb inlet catchbasins on different road slopes. The results of this exercise can be summarized as follows:
 - For a given flow depth, the gutter flow rate (Q_g) increases as the road slope increases.
 - The capture efficiency (Q_c) of curb inlet catchbasins decrease as the road slope increases.
 - The net result is that the relationship between flow depth and capture rate is largely independent of road slope: While approach flow vs. captured flow (Q_a vs. Q_c) varies significantly with road grade, flow depth vs. captured flow (D vs. Q_c) does not.

Since there was very little difference in the flow depth vs. captured flow curves for different road slopes, this family of curves was averaged to create a single standard curve for use in dual-drainage models.

Inlet Control Devices

The standard depth vs. capture flow curve was modified to account for the installation of ICDs in curb inlet catchbasins on continuous grade. Separate inlet curves were created for each standard ICD orifice size by capping the inlet rate on the depth vs. capture flow curve at the maximum flow rate through the ICD at a head of 1.2m (depth from centerline of CB lead to top of CICB frame).

1500 Merivale

Post-Development Model Parameters

Area ID	Catchment Area (ha)	Runoff Coefficient (C)	Percent Impervious (%)	No Depression (%)	Flow Path Length (m)	Equivalent Width (m)	Average Slope (%)
Roadways							
A-01a	0.079	0.78	83%	0%	12.94	61.04	2.5%
A-01b	0.114	0.55	50%	0%	17.55	64.98	2.5%
A-02a	0.043	0.72	74%	0%	8.85	48.57	2.5%
A-02b	0.068	0.74	77%	0%	14.29	47.57	2.5%
A-03a	0.033	0.81	87%	0%	9.11	36.23	2.5%
A-03b	0.046	0.75	79%	0%	13.97	32.93	2.5%
A-04a	0.082	0.86	94%	0%	20.22	40.55	2.5%
A-04b	0.066	0.74	77%	0%	18.48	35.72	2.5%
A-05a	0.078	0.90	100%	0%	18.25	42.73	2.5%
A-05b	0.068	0.75	79%	0%	14.29	47.59	2.5%
A-06a	0.042	0.90	100%	0%	14.32	29.34	2.5%
A-06b	0.039	0.74	77%	0%	14.31	27.25	2.5%
B-01a	0.099	0.82	89%	0%	14.85	66.69	2.5%
B-01b	0.050	0.80	86%	0%	9.74	51.36	2.5%
B-02a	0.029	0.84	91%	0%	10.47	27.70	2.5%
B-02b	0.018	0.90	100%	0%	8.66	20.79	2.5%
B-03a	0.138	0.85	93%	0%	16.43	84.00	2.5%
B-03b	0.054	0.66	66%	0%	5.20	103.88	2.5%
B-04a	0.007	0.90	100%	0%	2.92	23.94	2.5%
B-04b	0.011	0.65	64%	0%	5.04	21.81	2.5%
B-05	0.130	0.86	94%	0%	22.26	58.40	2.5%
Building Phases							
BLDG1	0.151	0.90	100%	0%	30.53	49.46	0.5%
P1-1	0.106	0.51	44%	0%	26.55	51.22	0.5%
P1-2	0.031	0.61	59%	0%	26.55	51.22	0.5%
BLDG2	0.243	0.90	100%	0%	-	-	0.5%
P2-1	0.163	0.20	0%	0%	-	-	0.5%
PH02	0.406	0.62	60%	0%	34.14	118.94	0.5%
BLDG3	0.076	0.90	100%	0%	-	-	0.5%
P3-01	0.065	0.20	0%	0%	-	-	0.5%
PH03	0.141	0.58	54%	0%	41.07	34.33	0.5%
BLDG4	0.242	0.90	100%	0%	-	-	0.5%
PH04	0.242	0.90	100%	0%	86.46	27.99	0.5%
BLDG5	0.336	0.90	100%	0%	-	-	0.5%
P5-1	0.181	0.70	71%	0%	-	-	0.5%
P5-2	0.101	0.45	36%	0%	-	-	0.5%

1500 Merivale

Post-Development Model Parameters

Area ID	Catchment Area (ha)	Runoff Coefficient (C)	Percent Impervious (%)	No Depression (%)	Flow Path Length (m)	Equivalent Width (m)	Average Slope (%)
Roadways							
A-01a	0.079	0.78	83%	0%	12.94	61.04	2.5%
PH05	0.618	0.77	81%	0%	73.28	84.28	0.5%
BLDG6	0.190	0.90	100%	0%	-	-	0.5%
P6-1	0.093	0.20	0%	0%	-	-	0.5%
P6-2	0.189	0.76	80%	0%	-	-	0.5%
PH06	0.472	0.71	72%	0%	54.86	86.04	0.5%
BLDG7	0.192	0.90	100%	0%	-	-	0.5%
P7-1	0.115	0.32	17%	0%	-	-	0.5%
PH07	0.307	0.68	69%	0%	42.17	72.80	0.5%
BLDG8	0.191	0.90	100%	0%	-	-	0.5%
P8-1	0.134	0.34	20%	0%	-	-	0.5%
PH08	0.325	0.67	67%	0%	32.95	98.62	0.5%
BLDG9	0.202	0.90	100%	0%	-	-	0.5%
P9-1	0.273	0.81	87%	0%	-	-	0.5%
P9-2	0.126	0.33	19%	0%	-	-	0.5%
PH09	0.601	0.74	77%	0%	95.06	63.26	0.5%
BLDG10	0.326	0.90	100%	0%	-	-	0.5%
P10-1	0.154	0.45	36%	0%	-	-	0.5%
P10-2	0.061	0.40	29%	0%	-	-	0.5%
P10-3	0.088	0.39	27%	0%	-	-	0.5%
PH10	0.629	0.67	67%	0%	94.74	66.36	0.5%
BLDG11	0.111	0.90	100%	0%	-	-	0.5%
P11-1	0.040	0.90	100%	0%	-	-	0.5%
P11-2	0.049	0.20	0%	0%	-	-	0.5%
PH11	0.200	0.73	76%	0%	34.23	58.44	0.5%
Park & Direct Runoff							
PARK1	0.519	0.40	29%	0%	55.30	94.22	1.7%
D-02	0.004	0.90	100%	0%	2.82	14.18	0.5%
D-04	0.011	0.20	0%	0%	3.41	32.23	0.5%

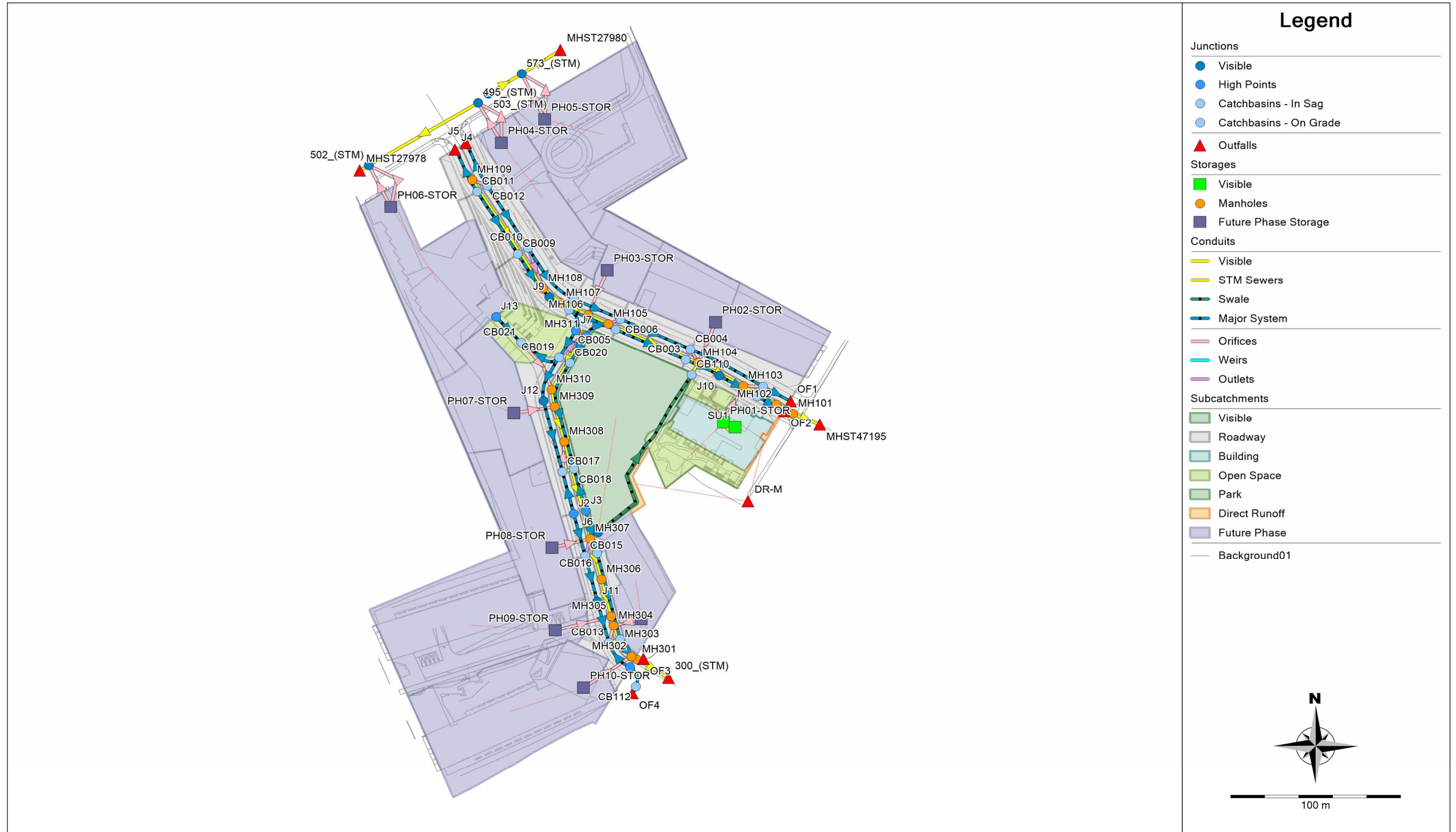

1500 Merivale

Peak Flows

Storm Distribution->		3hr Chicago					12hr SCS		
Return Period->		25mm	2yr	5yr	100yr	100yr +20%	2yr	5yr	100yr
To Merivale Road/ Parkwood Hills Minor System	North Outlet (Minor System)	96	130	202	272	314	77	134	217
	South Outlet (Minor System)	96	131	165	117	130	81	110	110
	Total to Merivale (Minor System)	192	261	367	389	444	158	244	327
To Merivale Road/ Parkwood Hills Major System	Direct Runoff	1	1	2	6	8	1	1	3
	North Outlet (Major System)	0	0	0	146	223	0	0	43
	South Outlet (Major System)	0	0	0	103	120	0	0	60
	Total to Merivale (Major System)	1	1	2	255	351	1	1	106
To Baseline/ Pinecrest Creek	Phase 4	1	3	5	8	9	4	5	8
	Phase 5	4	5	10	18	21	7	11	19
	Phase 6	3	4	4	15	17	4	6	17

1500 Merivale
ROW Ponding Depths

Structure	T/G (m)	Max. Static Ponding (Spill Depth)		2-yr Event (3hr)				5-yr Event (3hr)				100-yr Event (3hr)				100-yr Event (+20%) (3hr)			
		Elev. (m)	Depth (m)	Elev. (m)	Depth (m)	Cascading Flow?	Cascade Depth (m)	Elev. (m)	Depth (m)	Cascading Flow?	Cascade Depth (m)	Elev. (m)	Depth (m)	Cascading Flow?	Cascade Depth (m)	Elev. (m)	Depth (m)	Cascading Flow?	Cascade Depth (m)
CB01	93.97	94.07	0.10	92.89	0.00	N	0.00	93.96	0.00	N	0.00	94.15	0.18	Y	0.08	94.16	0.19	Y	0.09
CB02	93.97	94.07	0.10	92.94	0.00	N	0.00	93.87	0.00	N	0.00	94.15	0.18	Y	0.08	94.16	0.19	Y	0.09
CB13	94.44	94.55	0.11	93.51	0.00	N	0.00	94.30	0.00	N	0.00	94.64	0.20	Y	0.09	94.65	0.21	Y	0.10
CB14	94.44	94.55	0.11	93.76	0.00	N	0.00	94.49	0.05	N	0.00	94.64	0.20	Y	0.09	94.65	0.21	Y	0.10
CB17	95.70	95.84	0.14	95.43	0.00	N	0.00	95.75	0.05	N	0.00	95.84	0.14	N	0.00	95.86	0.16	Y	0.02
CB18	95.70	95.84	0.14	94.24	0.00	N	0.00	94.79	0.00	N	0.00	95.84	0.14	N	0.00	95.86	0.16	Y	0.02
CB21	96.60	96.80	0.20	96.46	0.00	N	0.00	96.63	0.03	N	0.00	96.76	0.16	N	0.00	96.82	0.22	Y	0.02

1500 Merivale
Design Storm Time Series Data
SCS Design Storms



S2-12.stm		S5-12.stm		S100-12.stm	
Duration	Intensity	Duration	Intensity	Duration	Intensity
min	mm/hr	min	mm/hr	min	mm/hr
0:00	0.00	0:00	0	0:00	0
0:30	1.27	0:30	1.69	0:30	2.82
1:00	0.59	1:00	0.79	1:00	1.31
1:30	1.10	1:30	1.46	1:30	2.44
2:00	1.10	2:00	1.46	2:00	2.44
2:30	1.44	2:30	1.91	2:30	3.19
3:00	1.27	3:00	1.69	3:00	2.82
3:30	1.69	3:30	2.25	3:30	3.76
4:00	1.69	4:00	2.25	4:00	3.76
4:30	2.29	4:30	3.03	4:30	5.07
5:00	2.88	5:00	3.82	5:00	6.39
5:30	4.57	5:30	6.07	5:30	10.14
6:00	36.24	6:00	48.08	6:00	80.38
6:30	9.23	6:30	12.25	6:30	20.47
7:00	4.06	7:00	5.39	7:00	9.01
7:30	2.71	7:30	3.59	7:30	6.01
8:00	2.37	8:00	3.15	8:00	5.26
8:30	1.86	8:30	2.47	8:30	4.13
9:00	1.95	9:00	2.58	9:00	4.32
9:30	1.27	9:30	1.69	9:30	2.82
10:00	1.02	10:00	1.35	10:00	2.25
10:30	1.44	10:30	1.91	10:30	3.19
11:00	0.93	11:00	1.24	11:00	2.07
11:30	0.85	11:30	1.12	11:30	1.88
12:00	0.85	12:00	1.12	12:00	1.88

Stormceptor® EF Sizing Report

Imbrium® Systems

ESTIMATED NET ANNUAL SEDIMENT (TSS) LOAD REDUCTION

03/20/2024

Province:	Ontario
City:	Ottawa
Nearest Rainfall Station:	OTTAWA CDA RCS
Climate Station Id:	6105978
Years of Rainfall Data:	20

Project Name:	1500 Merivale (N)
Project Number:	64165
Designer Name:	Kallie Auld
Designer Company:	Novatech
Designer Email:	k.auld@novatech-eng.com
Designer Phone:	613-254-9643
EOR Name:	
EOR Company:	
EOR Email:	
EOR Phone:	

Site Name:	1500 Merivale (N)
------------	-------------------

Drainage Area (ha):	2.113
---------------------	-------

% Imperviousness:	57.00
-------------------	-------

Runoff Coefficient 'c': 0.64

Particle Size Distribution:	Fine
-----------------------------	------

Target TSS Removal (%):	80.0
-------------------------	------

Required Water Quality Runoff Volume Capture (%):	90.00
Estimated Water Quality Flow Rate (L/s):	43.78
Oil / Fuel Spill Risk Site?	Yes
Upstream Flow Control?	No
Peak Conveyance (maximum) Flow Rate (L/s):	300.00
Influent TSS Concentration (mg/L):	200
Estimated Average Annual Sediment Load (kg/yr):	1311
Estimated Average Annual Sediment Volume (L/yr):	1066

Net Annual Sediment (TSS) Load Reduction Sizing Summary	
Stormceptor Model	TSS Removal Provided (%)
EFO4	66
EFO6	80
EFO8	87
EFO10	92
EFO12	95

Recommended Stormceptor EFO Model: EFO6

Estimated Net Annual Sediment (TSS) Load Reduction (%): 80

Water Quality Runoff Volume Capture (%): > 90



THIRD-PARTY TESTING AND VERIFICATION

► **Stormceptor® EF and Stormceptor® EFO** are the latest evolutions in the Stormceptor® oil-grit separator (OGS) technology series, and are designed to remove a wide variety of pollutants from stormwater and snowmelt runoff. These technologies have been third-party tested in accordance with the Canadian ETV **Procedure for Laboratory Testing of Oil-Grit Separators** and performance has been third-party verified in accordance with the **ISO 14034 Environmental Technology Verification (ETV)** protocol.

PERFORMANCE

► **Stormceptor® EF and EFO** remove stormwater pollutants through gravity separation and floatation, and feature a patent-pending design that generates positive removal of total suspended solids (TSS) throughout each storm event, including high-intensity storms. Captured pollutants include sediment, free oils, and sediment-bound pollutants such as nutrients, heavy metals, and petroleum hydrocarbons. Stormceptor is sized to remove a high level of TSS from the frequent rainfall events that contribute the vast majority of annual runoff volume and pollutant load. The technology incorporates an internal bypass to convey excessive stormwater flows from high-intensity storms through the device without resuspension and washout (scour) of previously captured pollutants. Proper routine maintenance ensures high pollutant removal performance and protection of downstream waterways.

PARTICLE SIZE DISTRIBUTION (PSD)

► The **Canadian ETV PSD** shown in the table below was used, or in part, for this sizing. This is the identical PSD that is referenced in the Canadian ETV **Procedure for Laboratory Testing of Oil-Grit Separators** for both sediment removal testing and scour testing. The Canadian ETV PSD contains a wide range of particle sizes in the sand and silt fractions, and is considered reasonably representative of the particle size fractions found in typical urban stormwater runoff.

Particle Size (µm)	Percent Less Than	Particle Size Fraction (µm)	Percent
1000	100	500-1000	5
500	95	250-500	5
250	90	150-250	15
150	75	100-150	15
100	60	75-100	10
75	50	50-75	5
50	45	20-50	10
20	35	8-20	15
8	20	5-8	10
5	10	2-5	5
2	5	<2	5

Stormceptor[®] EF Sizing Report

Rainfall Intensity (mm / hr)	Percent Rainfall Volume (%)	Cumulative Rainfall Volume (%)	Flow Rate (L/s)	Flow Rate (L/min)	Surface Loading Rate (L/min/m ²)	Removal Efficiency (%)	Incremental Removal (%)	Cumulative Removal (%)
0.50	8.6	8.6	1.89	113.0	43.0	100	8.6	8.6
1.00	20.3	29.0	3.77	226.0	86.0	98	20.0	28.6
2.00	16.2	45.2	7.54	453.0	172.0	87	14.1	42.7
3.00	12.0	57.2	11.31	679.0	258.0	81	9.7	52.4
4.00	8.4	65.6	15.08	905.0	344.0	77	6.5	58.9
5.00	5.9	71.6	18.86	1131.0	430.0	72	4.3	63.2
6.00	4.6	76.2	22.63	1358.0	516.0	69	3.2	66.4
7.00	3.1	79.3	26.40	1584.0	602.0	65	2.0	68.4
8.00	2.7	82.0	30.17	1810.0	688.0	64	1.8	70.1
9.00	3.3	85.3	33.94	2036.0	774.0	63	2.1	72.2
10.00	2.3	87.6	37.71	2263.0	860.0	63	1.4	73.7
11.00	1.6	89.2	41.48	2489.0	946.0	62	1.0	74.6
12.00	1.3	90.5	45.25	2715.0	1032.0	61	0.8	75.5
13.00	1.7	92.2	49.03	2942.0	1118.0	59	1.0	76.5
14.00	1.2	93.5	52.80	3168.0	1204.0	57	0.7	77.2
15.00	1.2	94.6	56.57	3394.0	1291.0	55	0.6	77.8
16.00	0.7	95.3	60.34	3620.0	1377.0	53	0.4	78.2
17.00	0.7	96.1	64.11	3847.0	1463.0	50	0.4	78.5
18.00	0.4	96.5	67.88	4073.0	1549.0	48	0.2	78.7
19.00	0.4	96.9	71.65	4299.0	1635.0	45	0.2	78.9
20.00	0.2	97.1	75.42	4525.0	1721.0	43	0.1	79.0
21.00	0.5	97.5	79.20	4752.0	1807.0	41	0.2	79.2
22.00	0.2	97.8	82.97	4978.0	1893.0	39	0.1	79.3
23.00	1.0	98.8	86.74	5204.0	1979.0	37	0.4	79.7
24.00	0.3	99.1	90.51	5431.0	2065.0	36	0.1	79.8
25.00	0.0	99.1	94.28	5657.0	2151.0	34	0.0	79.8
30.00	0.9	100.0	113.14	6788.0	2581.0	28	0.3	80.0
35.00	0.0	100.0	131.99	7920.0	3011.0	24	0.0	80.0
40.00	0.0	100.0	150.85	9051.0	3441.0	22	0.0	80.0
45.00	0.0	100.0	169.70	10182.0	3872.0	19	0.0	80.0
Estimated Net Annual Sediment (TSS) Load Reduction =								80 %

Climate Station ID: 6105978 Years of Rainfall Data: 20

Stormceptor® EF Sizing Report

RAINFALL DATA FROM OTTAWA CDA RCS RAINFALL STATION

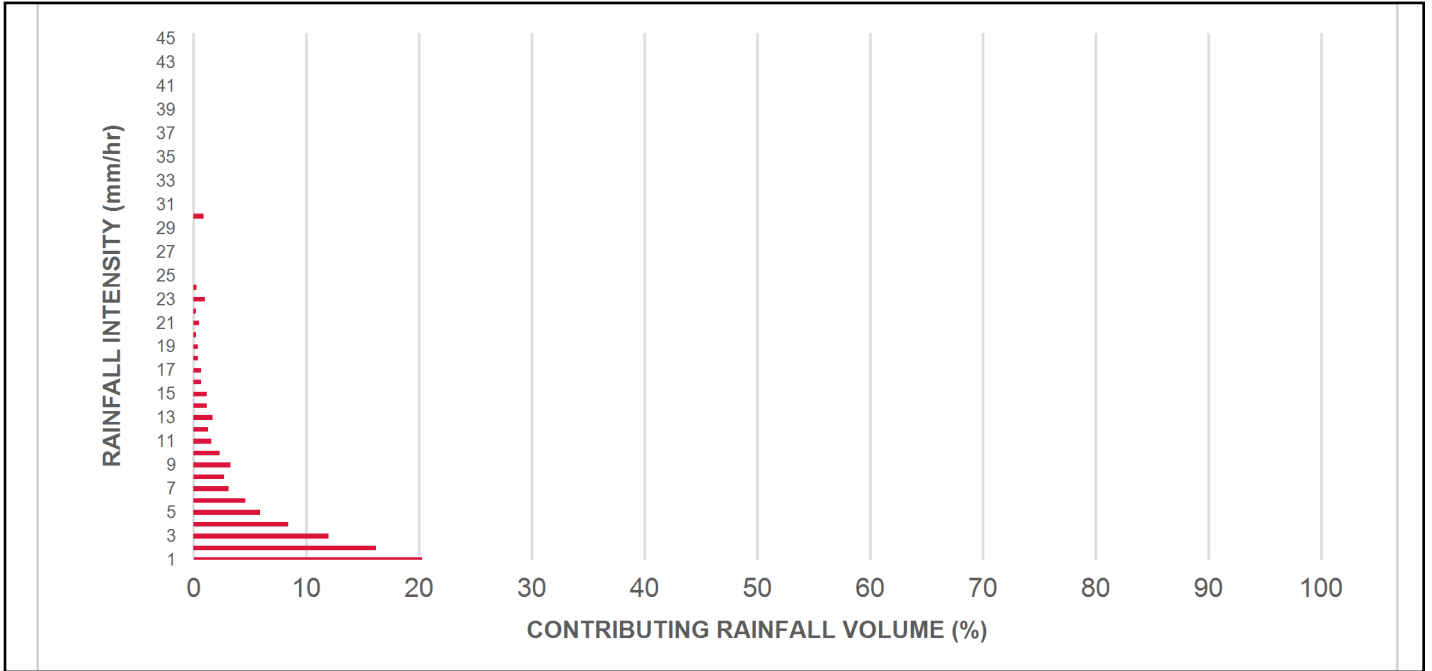

INCREMENTAL AND CUMULATIVE TSS REMOVAL FOR THE RECOMMENDED STORMCEPTOR® MODEL

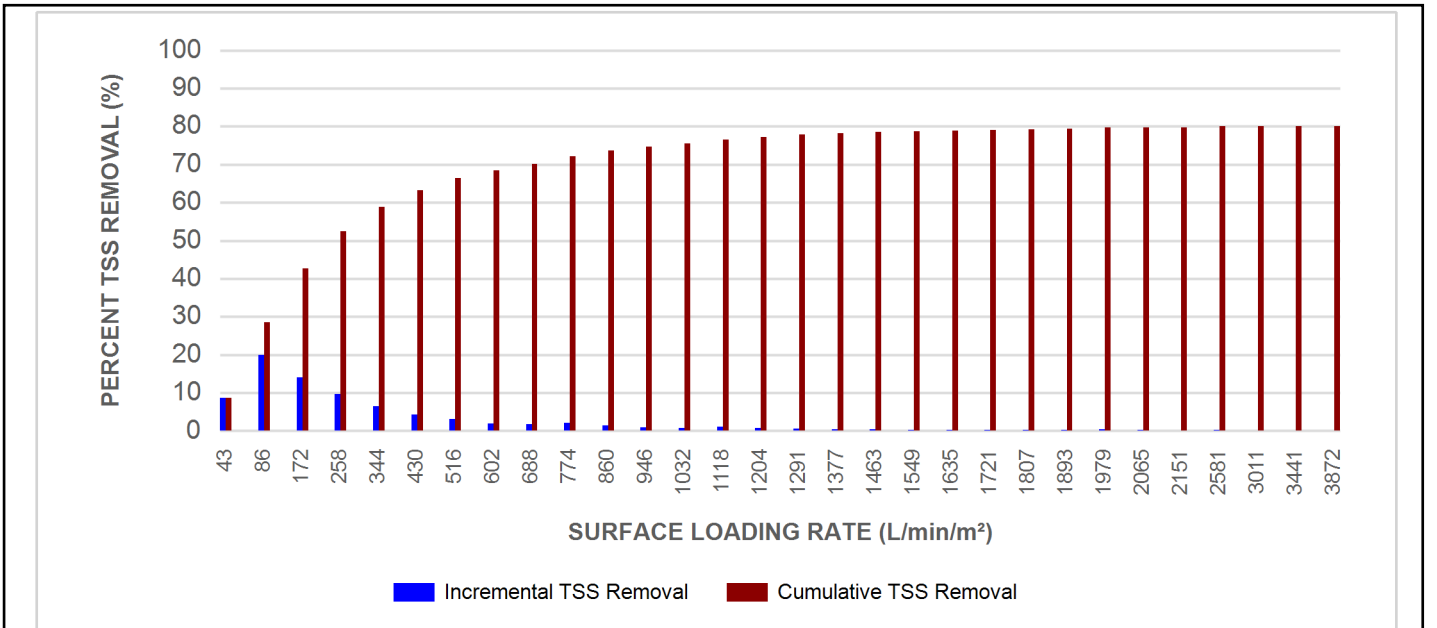

Stormceptor® EF Sizing Report

Maximum Pipe Diameter / Peak Conveyance

Stormceptor EF / EFO	Model Diameter		Min Angle Inlet / Outlet Pipes	Max Inlet Pipe Diameter		Max Outlet Pipe Diameter		Peak Conveyance Flow Rate	
	(m)	(ft)		(mm)	(in)	(mm)	(in)	(L/s)	(cfs)
EF4 / EFO4	1.2	4	90	609	24	609	24	425	15
EF6 / EFO6	1.8	6	90	914	36	914	36	990	35
EF8 / EFO8	2.4	8	90	1219	48	1219	48	1700	60
EF10 / EFO10	3.0	10	90	1828	72	1828	72	2830	100
EF12 / EFO12	3.6	12	90	1828	72	1828	72	2830	100

SCOUR PREVENTION AND ONLINE CONFIGURATION

► Stormceptor® EF and EFO feature an internal bypass and superior scour prevention technology that have been demonstrated in third-party testing according to the scour testing provisions of the Canadian ETV **Procedure for Laboratory Testing of Oil-Grit Separators**, and the exceptional scour test performance has been third-party verified in accordance with the ISO 14034 ETV protocol. As a result, Stormceptor EF and EFO are approved for online installation, eliminating the need for costly additional bypass structures, piping, and installation expense.

DESIGN FLEXIBILITY

► Stormceptor® EF and EFO offers design flexibility in one simplified platform, accepting stormwater flow from a single inlet pipe or multiple inlet pipes, and/or surface runoff through an inlet grate. The device can also serve as a junction structure, accommodate a 90-degree inlet-to-outlet bend angle, and can be modified to ensure performance in submerged conditions.

OIL CAPTURE AND RETENTION

► While Stormceptor® EF will capture and retain oil from dry weather spills and low intensity runoff, Stormceptor® EFO has demonstrated superior oil capture and greater than 99% oil retention in third-party testing according to the light liquid re-entrainment testing provisions of the Canadian ETV **Procedure for Laboratory Testing of Oil-Grit Separators**. Stormceptor EFO is recommended for sites where oil capture and retention is a requirement.

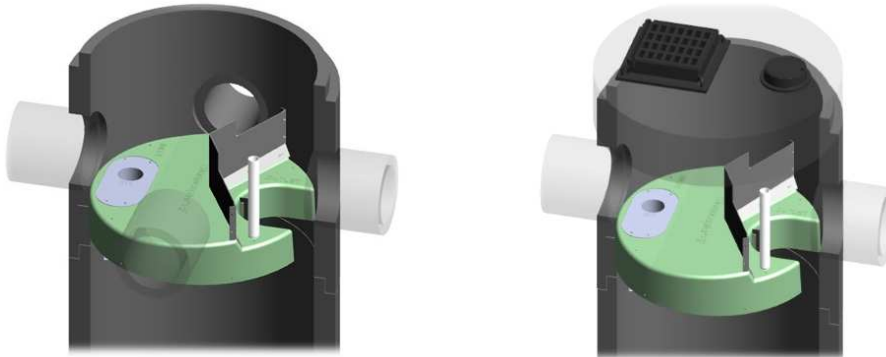

Stormceptor® EF Sizing Report

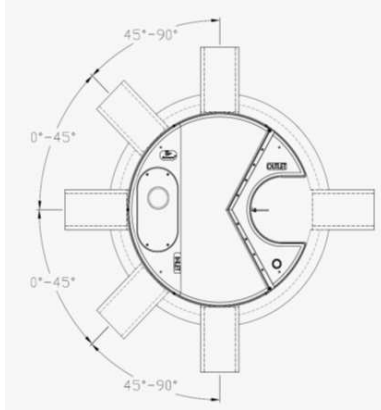

INLET-TO-OUTLET DROP

Elevation differential between inlet and outlet pipe inverts is dictated by the angle at which the inlet pipe(s) enters the unit.

0° - 45° : The inlet pipe is 1-inch (25mm) higher than the outlet pipe.

45° - 90° : The inlet pipe is 2-inches (50mm) higher than the outlet pipe.

HEAD LOSS

The head loss through Stormceptor EF is similar to that of a 60-degree bend structure. The applicable K value for calculating minor losses through the unit is 1.1. For submerged conditions the applicable K value is 3.0.

Pollutant Capacity

Stormceptor EF / EFO	Model Diameter		Depth (Outlet Pipe Invert to Sump Floor)		Oil Volume		Recommended Sediment Maintenance Depth *		Maximum Sediment Volume *		Maximum Sediment Mass **	
	(m)	(ft)	(m)	(ft)	(L)	(Gal)	(mm)	(in)	(L)	(ft³)	(kg)	(lb)
EF4 / EFO4	1.2	4	1.52	5.0	265	70	203	8	1190	42	1904	5250
EF6 / EFO6	1.8	6	1.93	6.3	610	160	305	12	3470	123	5552	15375
EF8 / EFO8	2.4	8	2.59	8.5	1070	280	610	24	8780	310	14048	38750
EF10 / EFO10	3.0	10	3.25	10.7	1670	440	610	24	17790	628	28464	78500
EF12 / EFO12	3.6	12	3.89	12.8	2475	655	610	24	31220	1103	49952	137875

*Increased sump depth may be added to increase sediment storage capacity

** Average density of wet packed sediment in sump = 1.6 kg/L (100 lb/ft³)

Feature	Benefit	Feature Appeals To
Patent-pending enhanced flow treatment and scour prevention technology	Superior, verified third-party performance	Regulator, Specifying & Design Engineer
Third-party verified light liquid capture and retention for EFO version	Proven performance for fuel/oil hotspot locations	Regulator, Specifying & Design Engineer, Site Owner
Functions as bend, junction or inlet structure	Design flexibility	Specifying & Design Engineer
Minimal drop between inlet and outlet	Site installation ease	Contractor
Large diameter outlet riser for inspection and maintenance	Easy maintenance access from grade	Maintenance Contractor & Site Owner

STANDARD STORMCEPTOR EF/EFO DRAWINGS

For standard details, please visit <http://www.imbriumsystems.com/stormwater-treatment-solutions/stormceptor-ef>

STANDARD STORMCEPTOR EF/EFO SPECIFICATION

For specifications, please visit <http://www.imbriumsystems.com/stormwater-treatment-solutions/stormceptor-ef>

STANDARD PERFORMANCE SPECIFICATION FOR “OIL GRIT SEPARATOR” (OGS) STORMWATER QUALITY TREATMENT DEVICE

PART 1 – GENERAL

1.1 WORK INCLUDED

This section specifies requirements for selecting, sizing, and designing an underground Oil Grit Separator (OGS) device for stormwater quality treatment, with third-party testing results and a Statement of Verification in accordance with ISO 14034 Environmental Management – Environmental Technology Verification (ETV).

1.2 REFERENCE STANDARDS & PROCEDURES

ISO 14034:2016 Environmental management – Environmental technology verification (ETV)

Canadian Environmental Technology Verification (ETV) Program’s **Procedure for Laboratory Testing of Oil-Grit Separators**

1.3 SUBMITTALS

1.3.1 All submittals, including sizing reports & shop drawings, shall be submitted upon request with each order to the contractor then forwarded to the Engineer of Record for review and acceptance. Shop drawings shall detail all OGS components, elevations, and sequence of construction.

1.3.2 Alternative devices shall have features identical to or greater than the specified device, including: treatment chamber diameter, treatment chamber wet volume, sediment storage volume, and oil storage volume.

1.3.3 Unless directed otherwise by the Engineer of Record, OGS stormwater quality treatment product substitutions or alternatives submitted within ten days prior to project bid shall not be accepted. All alternatives or substitutions submitted shall be signed and sealed by a local registered Professional Engineer, based on the exact same criteria detailed in Section 3, in entirety, subject to review and approval by the Engineer of Record.

PART 2 – PRODUCTS

2.1 OGS POLLUTANT STORAGE

The OGS device shall include a sump for sediment storage, and a protected volume for the capture and storage of petroleum hydrocarbons and buoyant gross pollutants. The minimum sediment & petroleum hydrocarbon storage capacity shall be as follows:

2.1.1	4 ft (1219 mm) Diameter OGS Units:	1.19 m ³ sediment / 265 L oil
	6 ft (1829 mm) Diameter OGS Units:	3.48 m ³ sediment / 609 L oil
	8 ft (2438 mm) Diameter OGS Units:	8.78 m ³ sediment / 1,071 L oil
	10 ft (3048 mm) Diameter OGS Units:	17.78 m ³ sediment / 1,673 L oil
	12 ft (3657 mm) Diameter OGS Units:	31.23 m ³ sediment / 2,476 L oil

PART 3 – PERFORMANCE & DESIGN

3.1 GENERAL

The OGS stormwater quality treatment device shall be verified in accordance with ISO 14034:2016 Environmental management – Environmental technology verification (ETV). The OGS stormwater quality treatment device shall

Stormceptor® EF Sizing Report

remove oil, sediment and gross pollutants from stormwater runoff during frequent wet weather events, and retain these pollutants during less frequent high flow wet weather events below the insert within the OGS for later removal during maintenance. The Manufacturer shall have at least ten (10) years of local experience, history and success in engineering design, manufacturing and production and supply of OGS stormwater quality treatment device systems, acceptable to the Engineer of Record.

3.2 SIZING METHODOLOGY

The OGS device shall be engineered, designed and sized to provide stormwater quality treatment based on treating a minimum of 90 percent of the average annual runoff volume and a minimum removal of an annual average 60% of the sediment (TSS) load based on the Particle Size Distribution (PSD) specified in the sizing report for the specified device. Sizing of the OGS shall be determined by use of a minimum ten (10) years of local historical rainfall data provided by Environment Canada. Sizing shall also be determined by use of the sediment removal performance data derived from the ISO 14034 ETV third-party verified laboratory testing data from testing conducted in accordance with the Canadian ETV protocol Procedure for Laboratory Testing of Oil-Grit Separators, as follows:

3.2.1 Sediment removal efficiency for a given surface loading rate and its associated flow rate shall be based on sediment removal efficiency demonstrated at the seven (7) tested surface loading rates specified in the protocol, ranging 40 L/min/m² to 1400 L/min/m², and as stated in the ISO 14034 ETV Verification Statement for the OGS device.

3.2.2 Sediment removal efficiency for surface loading rates between 40 L/min/m² and 1400 L/min/m² shall be based on linear interpolation of data between consecutive tested surface loading rates.

3.2.3 Sediment removal efficiency for surface loading rates less than the lowest tested surface loading rate of 40 L/min/m² shall be assumed to be identical to the sediment removal efficiency at 40 L/min/m². No extrapolation shall be allowed that results in a sediment removal efficiency that is greater than that demonstrated at 40 L/min/m².

3.2.4 Sediment removal efficiency for surface loading rates greater than the highest tested surface loading rate of 1400 L/min/m² shall assume zero sediment removal for the portion of flow that exceeds 1400 L/min/m², and shall be calculated using a simple proportioning formula, with 1400 L/min/m² in the numerator and the higher surface loading rate in the denominator, and multiplying the resulting fraction times the sediment removal efficiency at 1400 L/min/m².

The OGS device shall also have sufficient annual sediment storage capacity as specified and calculated in Section 2.1.

3.3 CANADIAN ETV or ISO 14034 ETV VERIFICATION OF SCOUR TESTING

The OGS device shall have Canadian ETV or ISO 14034 ETV Verification of third-party scour testing conducted in accordance with the Canadian ETV Program's **Procedure for Laboratory Testing of Oil-Grit Separators**.

3.3.1 To be acceptable for on-line installation, the OGS device must demonstrate an average scour test effluent concentration less than 10 mg/L at each surface loading rate tested, up to and including 2600 L/min/m².

3.4 LIGHT LIQUID RE-ENTRAINMENT SIMULATION TESTING

The OGS device shall have Canadian ETV or ISO 14034 ETV Verification of completed third-party Light Liquid Re-entrainment Simulation Testing in accordance with the Canadian ETV **Program's Procedure for Laboratory Testing of Oil-Grit Separators**, with results reported within the Canadian ETV or ISO 14034 ETV verification. This re-entrainment testing is conducted with the device pre-loaded with low density polyethylene (LDPE) plastic beads as a surrogate for light liquids such as oil and fuel. Testing is conducted on the same OGS unit tested for sediment removal to

Stormceptor[®] EF Sizing Report

assess whether light liquids captured after a spill are effectively retained at high flow rates.

3.4.1 For an OGS device to be an acceptable stormwater treatment device on a site where vehicular traffic occurs and the potential for an oil or fuel spill exists, the OGS device must have reported verified performance results of greater than 99% cumulative retention of LDPE plastic beads for the five specified surface loading rates (ranging 200 L/min/m² to 2600 L/min/m²) in accordance with the Light Liquid Re-entrainment Simulation Testing within the Canadian ETV Program's **Procedure for Laboratory Testing of Oil-Grit Separators**. However, an OGS device shall not be allowed if the Light Liquid Re-entrainment Simulation Testing was performed with screening components within the OGS device that are effective at retaining the LDPE plastic beads, but would not be expected to retain light liquids such as oil and fuel.

Stormceptor® EF Sizing Report

Imbrium® Systems

ESTIMATED NET ANNUAL SEDIMENT (TSS) LOAD REDUCTION

03/20/2024

Province:	Ontario
City:	Ottawa
Nearest Rainfall Station:	OTTAWA CDA RCS
Climate Station Id:	6105978
Years of Rainfall Data:	20

Project Name:	1500 Merivale (N)
Project Number:	64165
Designer Name:	Kallie Auld
Designer Company:	Novatech
Designer Email:	k.auld@novatech-eng.com
Designer Phone:	613-254-9643
EOR Name:	
EOR Company:	
EOR Email:	
EOR Phone:	

Site Name:	1500 Merivale (S)
------------	-------------------

Drainage Area (ha):	2.8
---------------------	-----

% Imperviousness:	75.00
-------------------	-------

Runoff Coefficient 'c': 0.75

Particle Size Distribution:	Fine
-----------------------------	------

Target TSS Removal (%):	80.0
-------------------------	------

Required Water Quality Runoff Volume Capture (%):	90.00
Estimated Water Quality Flow Rate (L/s):	67.78
Oil / Fuel Spill Risk Site?	Yes
Upstream Flow Control?	No
Peak Conveyance (maximum) Flow Rate (L/s):	130.00
Influent TSS Concentration (mg/L):	200
Estimated Average Annual Sediment Load (kg/yr):	2343
Estimated Average Annual Sediment Volume (L/yr):	1905

Net Annual Sediment (TSS) Load Reduction Sizing Summary	
Stormceptor Model	TSS Removal Provided (%)
EFO4	57
EFO6	73
EFO8	82
EFO10	88
EFO12	91

Recommended Stormceptor EFO Model: EFO8

Estimated Net Annual Sediment (TSS) Load Reduction (%): 82

Water Quality Runoff Volume Capture (%): > 90



THIRD-PARTY TESTING AND VERIFICATION

► **Stormceptor® EF and Stormceptor® EFO** are the latest evolutions in the Stormceptor® oil-grit separator (OGS) technology series, and are designed to remove a wide variety of pollutants from stormwater and snowmelt runoff. These technologies have been third-party tested in accordance with the Canadian ETV **Procedure for Laboratory Testing of Oil-Grit Separators** and performance has been third-party verified in accordance with the **ISO 14034 Environmental Technology Verification (ETV)** protocol.

PERFORMANCE

► **Stormceptor® EF and EFO** remove stormwater pollutants through gravity separation and floatation, and feature a patent-pending design that generates positive removal of total suspended solids (TSS) throughout each storm event, including high-intensity storms. Captured pollutants include sediment, free oils, and sediment-bound pollutants such as nutrients, heavy metals, and petroleum hydrocarbons. Stormceptor is sized to remove a high level of TSS from the frequent rainfall events that contribute the vast majority of annual runoff volume and pollutant load. The technology incorporates an internal bypass to convey excessive stormwater flows from high-intensity storms through the device without resuspension and washout (scour) of previously captured pollutants. Proper routine maintenance ensures high pollutant removal performance and protection of downstream waterways.

PARTICLE SIZE DISTRIBUTION (PSD)

► The **Canadian ETV PSD** shown in the table below was used, or in part, for this sizing. This is the identical PSD that is referenced in the Canadian ETV **Procedure for Laboratory Testing of Oil-Grit Separators** for both sediment removal testing and scour testing. The Canadian ETV PSD contains a wide range of particle sizes in the sand and silt fractions, and is considered reasonably representative of the particle size fractions found in typical urban stormwater runoff.

Particle Size (µm)	Percent Less Than	Particle Size Fraction (µm)	Percent
1000	100	500-1000	5
500	95	250-500	5
250	90	150-250	15
150	75	100-150	15
100	60	75-100	10
75	50	50-75	5
50	45	20-50	10
20	35	8-20	15
8	20	5-8	10
5	10	2-5	5
2	5	<2	5

Stormceptor® EF Sizing Report

Rainfall Intensity (mm / hr)	Percent Rainfall Volume (%)	Cumulative Rainfall Volume (%)	Flow Rate (L/s)	Flow Rate (L/min)	Surface Loading Rate (L/min/m ²)	Removal Efficiency (%)	Incremental Removal (%)	Cumulative Removal (%)
0.50	8.6	8.6	2.92	175.0	37.0	100	8.6	8.6
1.00	20.3	29.0	5.84	350.0	75.0	100	20.3	29.0
2.00	16.2	45.2	11.68	701.0	149.0	89	14.5	43.5
3.00	12.0	57.2	17.51	1051.0	224.0	82	9.9	53.3
4.00	8.4	65.6	23.35	1401.0	298.0	79	6.7	60.0
5.00	5.9	71.6	29.19	1751.0	373.0	75	4.5	64.5
6.00	4.6	76.2	35.03	2102.0	447.0	72	3.3	67.8
7.00	3.1	79.3	40.87	2452.0	522.0	68	2.1	69.9
8.00	2.7	82.0	46.70	2802.0	596.0	65	1.8	71.7
9.00	3.3	85.3	52.54	3153.0	671.0	64	2.1	73.8
10.00	2.3	87.6	58.38	3503.0	745.0	64	1.5	75.3
11.00	1.6	89.2	64.22	3853.0	820.0	63	1.0	76.3
12.00	1.3	90.5	70.06	4203.0	894.0	62	0.8	77.1
13.00	1.7	92.2	75.89	4554.0	969.0	62	1.1	78.1
14.00	1.2	93.5	81.73	4904.0	1043.0	61	0.7	78.9
15.00	1.2	94.6	87.57	5254.0	1118.0	59	0.7	79.6
16.00	0.7	95.3	93.41	5604.0	1192.0	57	0.4	80.0
17.00	0.7	96.1	99.25	5955.0	1267.0	56	0.4	80.4
18.00	0.4	96.5	105.08	6305.0	1341.0	54	0.2	80.6
19.00	0.4	96.9	110.92	6655.0	1416.0	52	0.2	80.8
20.00	0.2	97.1	116.76	7006.0	1491.0	49	0.1	80.9
21.00	0.5	97.5	122.60	7356.0	1565.0	47	0.2	81.1
22.00	0.2	97.8	128.44	7706.0	1640.0	45	0.1	81.2
23.00	1.0	98.8	134.27	8056.0	1714.0	43	0.4	81.7
24.00	0.3	99.1	140.11	8407.0	1789.0	41	0.1	81.8
25.00	0.0	99.1	145.95	8757.0	1863.0	39	0.0	81.8
30.00	0.9	100.0	175.14	10508.0	2236.0	33	0.3	82.1
35.00	0.0	100.0	204.33	12260.0	2608.0	28	0.0	82.1
40.00	0.0	100.0	233.52	14011.0	2981.0	25	0.0	82.1
45.00	0.0	100.0	262.71	15763.0	3354.0	22	0.0	82.1
Estimated Net Annual Sediment (TSS) Load Reduction =								82 %

Climate Station ID: 6105978 Years of Rainfall Data: 20

Stormceptor® EF Sizing Report

RAINFALL DATA FROM OTTAWA CDA RCS RAINFALL STATION

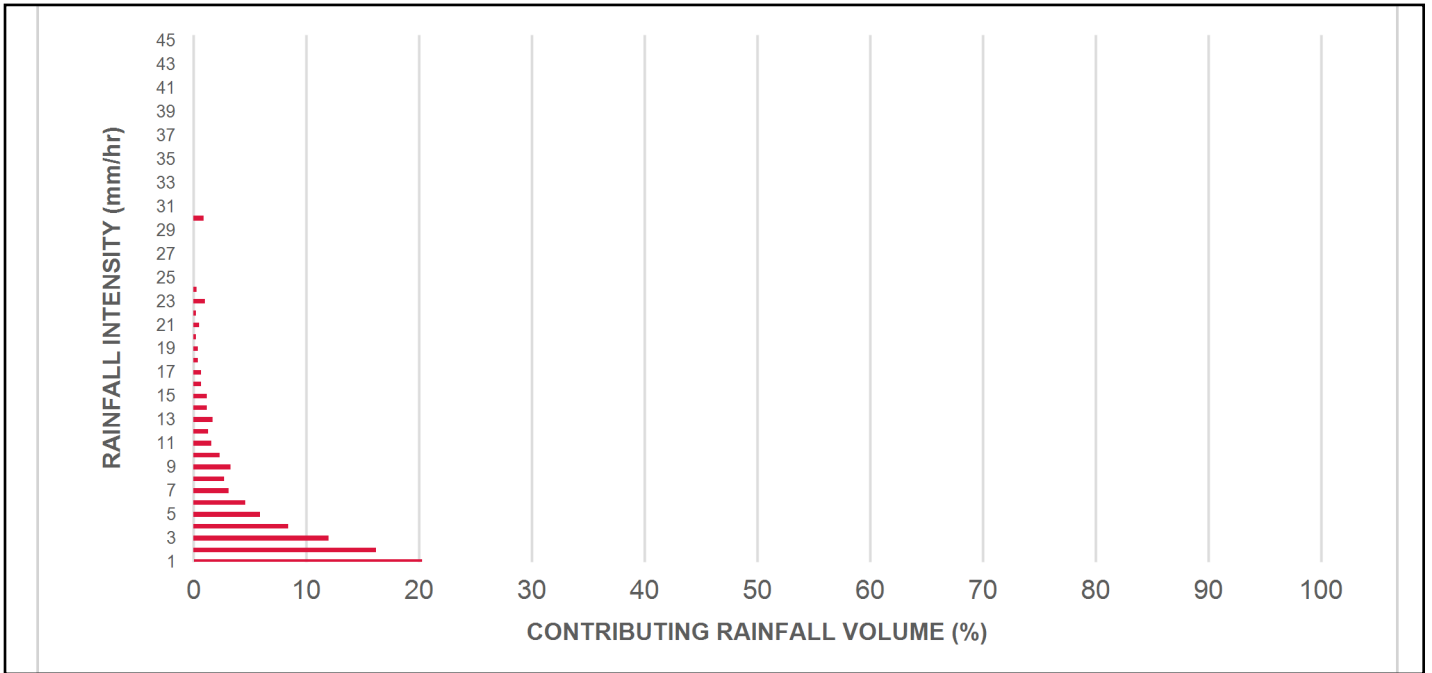

INCREMENTAL AND CUMULATIVE TSS REMOVAL FOR THE RECOMMENDED STORMCEPTOR® MODEL

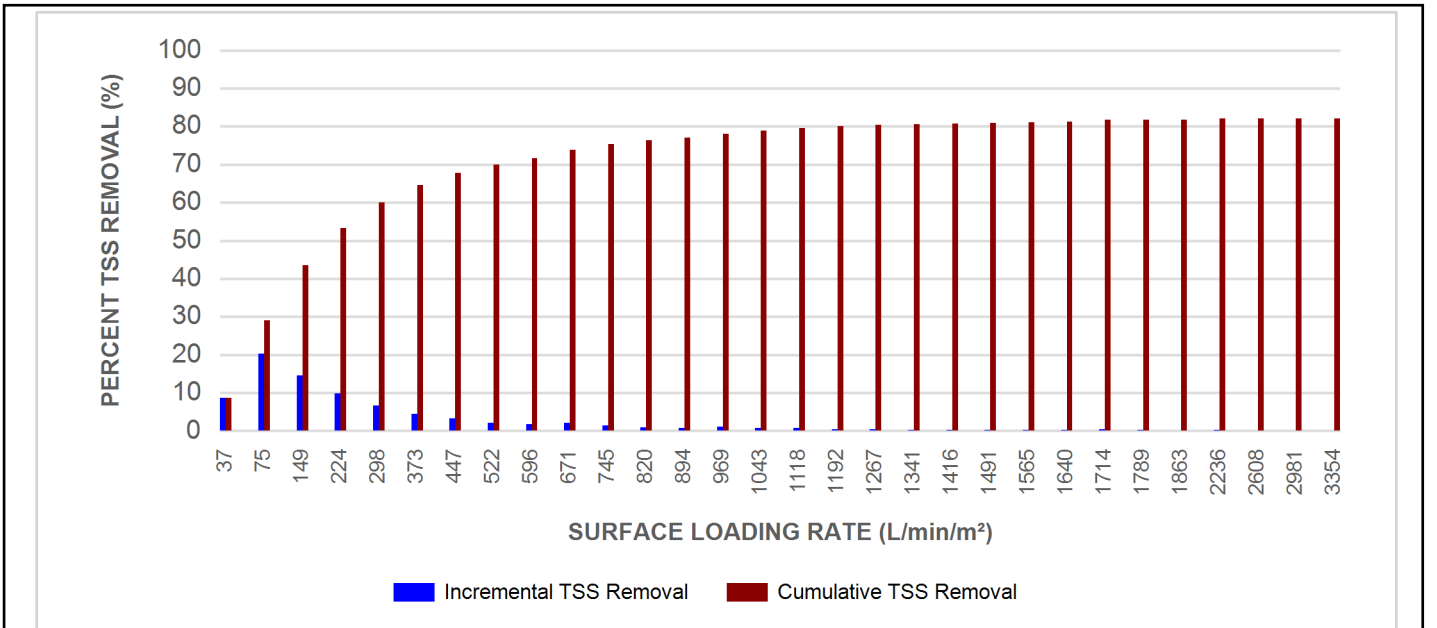

Stormceptor® EF Sizing Report

Maximum Pipe Diameter / Peak Conveyance

Stormceptor EF / EFO	Model Diameter		Min Angle Inlet / Outlet Pipes	Max Inlet Pipe Diameter		Max Outlet Pipe Diameter		Peak Conveyance Flow Rate	
	(m)	(ft)		(mm)	(in)	(mm)	(in)	(L/s)	(cfs)
EF4 / EFO4	1.2	4	90	609	24	609	24	425	15
EF6 / EFO6	1.8	6	90	914	36	914	36	990	35
EF8 / EFO8	2.4	8	90	1219	48	1219	48	1700	60
EF10 / EFO10	3.0	10	90	1828	72	1828	72	2830	100
EF12 / EFO12	3.6	12	90	1828	72	1828	72	2830	100

SCOUR PREVENTION AND ONLINE CONFIGURATION

► Stormceptor® EF and EFO feature an internal bypass and superior scour prevention technology that have been demonstrated in third-party testing according to the scour testing provisions of the Canadian ETV **Procedure for Laboratory Testing of Oil-Grit Separators**, and the exceptional scour test performance has been third-party verified in accordance with the ISO 14034 ETV protocol. As a result, Stormceptor EF and EFO are approved for online installation, eliminating the need for costly additional bypass structures, piping, and installation expense.

DESIGN FLEXIBILITY

► Stormceptor® EF and EFO offers design flexibility in one simplified platform, accepting stormwater flow from a single inlet pipe or multiple inlet pipes, and/or surface runoff through an inlet grate. The device can also serve as a junction structure, accommodate a 90-degree inlet-to-outlet bend angle, and can be modified to ensure performance in submerged conditions.

OIL CAPTURE AND RETENTION

► While Stormceptor® EF will capture and retain oil from dry weather spills and low intensity runoff, Stormceptor® EFO has demonstrated superior oil capture and greater than 99% oil retention in third-party testing according to the light liquid re-entrainment testing provisions of the Canadian ETV **Procedure for Laboratory Testing of Oil-Grit Separators**. Stormceptor EFO is recommended for sites where oil capture and retention is a requirement.

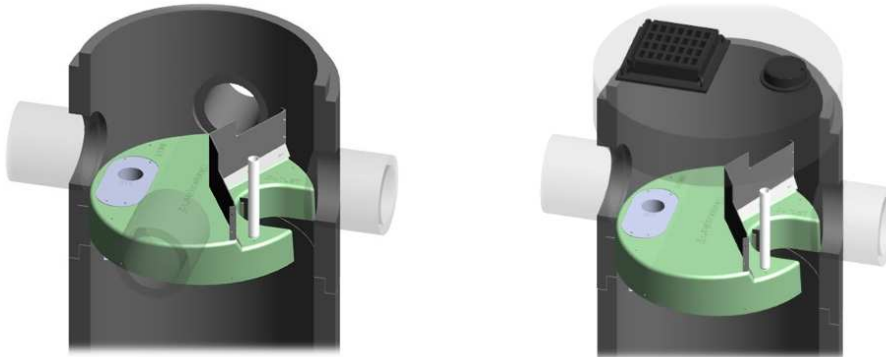

Stormceptor® EF Sizing Report

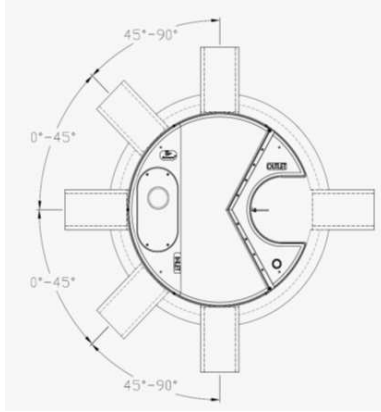

INLET-TO-OUTLET DROP

Elevation differential between inlet and outlet pipe inverts is dictated by the angle at which the inlet pipe(s) enters the unit.

0° - 45° : The inlet pipe is 1-inch (25mm) higher than the outlet pipe.

45° - 90° : The inlet pipe is 2-inches (50mm) higher than the outlet pipe.

HEAD LOSS

The head loss through Stormceptor EF is similar to that of a 60-degree bend structure. The applicable K value for calculating minor losses through the unit is 1.1. For submerged conditions the applicable K value is 3.0.

Pollutant Capacity

Stormceptor EF / EFO	Model Diameter		Depth (Outlet Pipe Invert to Sump Floor)		Oil Volume		Recommended Sediment Maintenance Depth *		Maximum Sediment Volume *		Maximum Sediment Mass **	
	(m)	(ft)	(m)	(ft)	(L)	(Gal)	(mm)	(in)	(L)	(ft³)	(kg)	(lb)
EF4 / EFO4	1.2	4	1.52	5.0	265	70	203	8	1190	42	1904	5250
EF6 / EFO6	1.8	6	1.93	6.3	610	160	305	12	3470	123	5552	15375
EF8 / EFO8	2.4	8	2.59	8.5	1070	280	610	24	8780	310	14048	38750
EF10 / EFO10	3.0	10	3.25	10.7	1670	440	610	24	17790	628	28464	78500
EF12 / EFO12	3.6	12	3.89	12.8	2475	655	610	24	31220	1103	49952	137875

*Increased sump depth may be added to increase sediment storage capacity

** Average density of wet packed sediment in sump = 1.6 kg/L (100 lb/ft³)

Feature	Benefit	Feature Appeals To
Patent-pending enhanced flow treatment and scour prevention technology	Superior, verified third-party performance	Regulator, Specifying & Design Engineer
Third-party verified light liquid capture and retention for EFO version	Proven performance for fuel/oil hotspot locations	Regulator, Specifying & Design Engineer, Site Owner
Functions as bend, junction or inlet structure	Design flexibility	Specifying & Design Engineer
Minimal drop between inlet and outlet	Site installation ease	Contractor
Large diameter outlet riser for inspection and maintenance	Easy maintenance access from grade	Maintenance Contractor & Site Owner

STANDARD STORMCEPTOR EF/EFO DRAWINGS

For standard details, please visit <http://www.imbriumsystems.com/stormwater-treatment-solutions/stormceptor-ef>

STANDARD STORMCEPTOR EF/EFO SPECIFICATION

For specifications, please visit <http://www.imbriumsystems.com/stormwater-treatment-solutions/stormceptor-ef>

STANDARD PERFORMANCE SPECIFICATION FOR “OIL GRIT SEPARATOR” (OGS) STORMWATER QUALITY TREATMENT DEVICE

PART 1 – GENERAL

1.1 WORK INCLUDED

This section specifies requirements for selecting, sizing, and designing an underground Oil Grit Separator (OGS) device for stormwater quality treatment, with third-party testing results and a Statement of Verification in accordance with ISO 14034 Environmental Management – Environmental Technology Verification (ETV).

1.2 REFERENCE STANDARDS & PROCEDURES

ISO 14034:2016 Environmental management – Environmental technology verification (ETV)

Canadian Environmental Technology Verification (ETV) Program’s **Procedure for Laboratory Testing of Oil-Grit Separators**

1.3 SUBMITTALS

1.3.1 All submittals, including sizing reports & shop drawings, shall be submitted upon request with each order to the contractor then forwarded to the Engineer of Record for review and acceptance. Shop drawings shall detail all OGS components, elevations, and sequence of construction.

1.3.2 Alternative devices shall have features identical to or greater than the specified device, including: treatment chamber diameter, treatment chamber wet volume, sediment storage volume, and oil storage volume.

1.3.3 Unless directed otherwise by the Engineer of Record, OGS stormwater quality treatment product substitutions or alternatives submitted within ten days prior to project bid shall not be accepted. All alternatives or substitutions submitted shall be signed and sealed by a local registered Professional Engineer, based on the exact same criteria detailed in Section 3, in entirety, subject to review and approval by the Engineer of Record.

PART 2 – PRODUCTS

2.1 OGS POLLUTANT STORAGE

The OGS device shall include a sump for sediment storage, and a protected volume for the capture and storage of petroleum hydrocarbons and buoyant gross pollutants. The minimum sediment & petroleum hydrocarbon storage capacity shall be as follows:

2.1.1	4 ft (1219 mm) Diameter OGS Units:	1.19 m ³ sediment / 265 L oil
	6 ft (1829 mm) Diameter OGS Units:	3.48 m ³ sediment / 609 L oil
	8 ft (2438 mm) Diameter OGS Units:	8.78 m ³ sediment / 1,071 L oil
	10 ft (3048 mm) Diameter OGS Units:	17.78 m ³ sediment / 1,673 L oil
	12 ft (3657 mm) Diameter OGS Units:	31.23 m ³ sediment / 2,476 L oil

PART 3 – PERFORMANCE & DESIGN

3.1 GENERAL

The OGS stormwater quality treatment device shall be verified in accordance with ISO 14034:2016 Environmental management – Environmental technology verification (ETV). The OGS stormwater quality treatment device shall

Stormceptor® EF Sizing Report

remove oil, sediment and gross pollutants from stormwater runoff during frequent wet weather events, and retain these pollutants during less frequent high flow wet weather events below the insert within the OGS for later removal during maintenance. The Manufacturer shall have at least ten (10) years of local experience, history and success in engineering design, manufacturing and production and supply of OGS stormwater quality treatment device systems, acceptable to the Engineer of Record.

3.2 SIZING METHODOLOGY

The OGS device shall be engineered, designed and sized to provide stormwater quality treatment based on treating a minimum of 90 percent of the average annual runoff volume and a minimum removal of an annual average 60% of the sediment (TSS) load based on the Particle Size Distribution (PSD) specified in the sizing report for the specified device. Sizing of the OGS shall be determined by use of a minimum ten (10) years of local historical rainfall data provided by Environment Canada. Sizing shall also be determined by use of the sediment removal performance data derived from the ISO 14034 ETV third-party verified laboratory testing data from testing conducted in accordance with the Canadian ETV protocol Procedure for Laboratory Testing of Oil-Grit Separators, as follows:

3.2.1 Sediment removal efficiency for a given surface loading rate and its associated flow rate shall be based on sediment removal efficiency demonstrated at the seven (7) tested surface loading rates specified in the protocol, ranging 40 L/min/m² to 1400 L/min/m², and as stated in the ISO 14034 ETV Verification Statement for the OGS device.

3.2.2 Sediment removal efficiency for surface loading rates between 40 L/min/m² and 1400 L/min/m² shall be based on linear interpolation of data between consecutive tested surface loading rates.

3.2.3 Sediment removal efficiency for surface loading rates less than the lowest tested surface loading rate of 40 L/min/m² shall be assumed to be identical to the sediment removal efficiency at 40 L/min/m². No extrapolation shall be allowed that results in a sediment removal efficiency that is greater than that demonstrated at 40 L/min/m².

3.2.4 Sediment removal efficiency for surface loading rates greater than the highest tested surface loading rate of 1400 L/min/m² shall assume zero sediment removal for the portion of flow that exceeds 1400 L/min/m², and shall be calculated using a simple proportioning formula, with 1400 L/min/m² in the numerator and the higher surface loading rate in the denominator, and multiplying the resulting fraction times the sediment removal efficiency at 1400 L/min/m².

The OGS device shall also have sufficient annual sediment storage capacity as specified and calculated in Section 2.1.

3.3 CANADIAN ETV or ISO 14034 ETV VERIFICATION OF SCOUR TESTING

The OGS device shall have Canadian ETV or ISO 14034 ETV Verification of third-party scour testing conducted in accordance with the Canadian ETV Program's **Procedure for Laboratory Testing of Oil-Grit Separators**.

3.3.1 To be acceptable for on-line installation, the OGS device must demonstrate an average scour test effluent concentration less than 10 mg/L at each surface loading rate tested, up to and including 2600 L/min/m².

3.4 LIGHT LIQUID RE-ENTRAINMENT SIMULATION TESTING

The OGS device shall have Canadian ETV or ISO 14034 ETV Verification of completed third-party Light Liquid Re-entrainment Simulation Testing in accordance with the Canadian ETV **Program's Procedure for Laboratory Testing of Oil-Grit Separators**, with results reported within the Canadian ETV or ISO 14034 ETV verification. This re-entrainment testing is conducted with the device pre-loaded with low density polyethylene (LDPE) plastic beads as a surrogate for light liquids such as oil and fuel. Testing is conducted on the same OGS unit tested for sediment removal to

Stormceptor® EF Sizing Report

assess whether light liquids captured after a spill are effectively retained at high flow rates.

3.4.1 For an OGS device to be an acceptable stormwater treatment device on a site where vehicular traffic occurs and the potential for an oil or fuel spill exists, the OGS device must have reported verified performance results of greater than 99% cumulative retention of LDPE plastic beads for the five specified surface loading rates (ranging 200 L/min/m² to 2600 L/min/m²) in accordance with the Light Liquid Re-entrainment Simulation Testing within the Canadian ETV Program's **Procedure for Laboratory Testing of Oil-Grit Separators**. However, an OGS device shall not be allowed if the Light Liquid Re-entrainment Simulation Testing was performed with screening components within the OGS device that are effective at retaining the LDPE plastic beads, but would not be expected to retain light liquids such as oil and fuel.

Appendix E
Water Servicing

Proposed Development Conditions - Baseline Connections

	Building B Phase 4	Building C Phase 5	Building D Phase 6	Totals
Studio	8	10	20	38
1 Bed Apartment	181	170	120	471
2 Bed Apartment	28	65	33	126
3 Bed Apartment	10	12	23	45
Townhome	0	0	0	0
Number of units	227	257	196	680
Population	354.4	425.7	336.6	1116.7
Total Res Daily Volume	99232.00	119196.00	94248.00	312676.00
Commercial area (m2)	118.11	101.95	56.99	277.05
Total Com Daily Volume	952.5	822.18	459.60	2234.27
Total Daily Volume (Liters)	100184.5	120018.2	94707.60	314910.3
Avg Day Demand (L/s)	1.160	1.389	1.096	3.64
Max Day Demand (L/s)	2.888	3.463	2.735	9.09
Peak Hour Demand (L/s)	6.347	7.613	6.014	19.974

Proposed Development Conditions - Merivale Connection

	Building A Phase 1	Building B Phase 2	Building B Phase 3	Building D Phase 7	Building D Phase 8	Building D Phase 9	Building E Phase 10	Building E Phase 11	Park	Totals
Studio	1	9	0	0	16	0	0	1		27
1 Bed Apartment	74	218	21	119	153	170	190	43		988
2 Bed Apartment	28	27	46	35	23	42	89	14		304
3 Bed Apartment	15	14	0	0	0	0	8	22		59
Townhome	7	8	0	8	6	0	0	5		34
Park Area (ha)	n/a	n/a	n/a	n/a	n/a	n/a	n/a	n/a	0.56	0.56
Number of units	125	276	67	162	198	212	287	85	n/a	1412
Population	229.2	439.5	126	261.7	301.1	326.2	477.7	172.7	n/a	2334.1
Total Res Daily Volume	64176.00	123060.00	35280.00	73276.00	84308.00	91336.00	133756.00	48356.00	156.8	653704.80
Commercial area (m2)	168.52	135.26	n/a	n/a	n/a	156.36	412.3	170	n/a	1042.44
Total Com Daily Volume	1359.03	1090.81	0.00	0.00	0.00	1260.97	3325.00	1370.97	0.00	8406.77
Total Daily Volume (Liters)	65535.0	124150.8	35280.0	73276.0	84308.0	92597.0	137081.0	49727.0	156.8	662111.6
Avg Day Demand (L/s)	0.759	1.437	0.408	0.848	0.976	1.072	1.587	0.576	0.002	7.66
Max Day Demand (L/s)	1.881	3.580	1.021	2.120	2.439	2.665	3.928	1.423	0.005	19.06
Peak Hour Demand (L/s)	4.128	7.868	2.246	4.665	5.367	5.854	8.618	3.121	0.010	41.88

Design Parameters

Use	Daily Demand Volume		Source
Studio	1.4	Person/unit	City of Ottawa Sewer Design Guidelines
1 Bed Apartment	1.4	Person/unit	
2 Bed Apartment	2.1	Person/unit	
3 Bed Apartment	3.1	Person/unit	
Townhome Unit	2.7	Person/unit	
Average Residential Flow	280	L/c/day	
Park	1	unit/ha	Flow assumed to be equivalent to a single unit per park hectare
Commercial:	75	L/9.3m2/day	Daily Demands from OBC Table 8.2.1.3

Residential Peaking Factors City of Ottawa Water Distribution Guidelines:

Conditions	Peaking Factor	Units
Maximum Day	2.5 x avg day	L/c/day
Peak Hour	2.2 x max day	L/c/day

Commercial Peaking Factors City of Ottawa Water Distribution Guidelines

Conditions	Peaking Factor	Units
Maximum Day	1.5 x avg day	L/c/day
Peak Hour	1.8 x max day	L/c/day

FUS - Fire Flow Calculations

As per 2020 Fire Underwriter's Survey Guidelines



Engineers, Planners & Landscape Architects

Novatech Project #: 121009
 Project Name: 1500 Merivale Road
 Date: 11/23/2022
 Input By: Curtis Ferguson, E.I.T.
 Reviewed By: Anthony Mestwarp, P.Eng

Legend

Input by User
 No Information or Input Required

Building Description: Phase 4 - 11 Storey Tower, 9 Storey Midrise
 Type I - Fire resistive construction (2 hrs)

Step		Choose		Value Used	Total Fire Flow (L/min)	
Base Fire Flow						
1	Construction Material			Multiplier		
	Coefficient related to type of construction C	Type V - Wood frame		1.5	0.6	
		Type IV - Mass Timber		Varies		
		Type III - Ordinary construction		1		
		Type II - Non-combustible construction		0.8		
Type I - Fire resistive construction (2 hrs)		Yes	0.6			
2	Floor Area					
	A	Podium Level Footprint (m ²)	2084			
		Total Floors/Storeys (Podium)	9			
		Tower Footprint (m ²)	753			
		Total Floors/Storeys (Tower)	2			
		Protected Openings (1 hr)	Yes			
	A, Total Effective Floor Area (m ²)			3,126		
F	Base fire flow without reductions					
	F = 220 C (A)^{0.5}			7,000		
Reductions or Surcharges						
3	Occupancy hazard reduction or surcharge		FUS Table 3	Reduction/Surcharge		
	(1)	Non-combustible		-25%	-15%	
		Limited combustible	Yes	-15%		
		Combustible		0%		
		Free burning		15%		
		Rapid burning		25%		
				5,950		
4	Sprinkler Reduction		FUS Table 4	Reduction		
	(2)	Adequately Designed System (NFPA 13)	Yes	-30%	-30%	
		Standard Water Supply	Yes	-10%	-10%	
		Fully Supervised System	Yes	-10%	-10%	
		Cumulative Sub-Total			-50%	
		Area of Sprinklered Coverage (m²)	15196.5	75%		
			Cumulative Total	-38%		
5	Exposure Surcharge per		FUS Table 5	Surcharge		
	(3)	North Side	>30m		0%	
		East Side	10.1 - 20 m		15%	
		South Side	Firewall-2hr		0%	
		West Side	20.1 - 30 m		10%	
					Cumulative Total	25%
Results						
6	(1) + (2) + (3)	Total Required Fire Flow, rounded to nearest 1000L/min			L/min	5,000
		(2,000 L/min < Fire Flow < 45,000 L/min)			or	83
					or	USGPM
7	Storage Volume	Required Duration of Fire Flow (hours)			Hours	1.75
		Required Volume of Fire Flow (m ³)			m ³	525

FUS - Fire Flow Calculations

As per 2020 Fire Underwriter's Survey Guidelines



Engineers, Planners & Landscape Architects

Novatech Project #: 121009
 Project Name: 1500 Merivale Road
 Date: 11/23/2022
 Input By: Curtis Ferguson, E.I.T.
 Reviewed By: Anthony Mestwarp, P.Eng

Legend
 Input by User
 No Information or Input Required

Building Description: Phase 5 - 9 & 6 Storey Midrise
 Type I - Fire resistive construction (2 hrs)

Step		Choose		Value Used	Total Fire Flow (L/min)		
Base Fire Flow							
1	Construction Material			Multiplier			
	Coefficient related to type of construction C	Type V - Wood frame		1.5	0.6		
		Type IV - Mass Timber		Varies			
		Type III - Ordinary construction		1			
		Type II - Non-combustible construction		0.8			
Type I - Fire resistive construction (2 hrs)		Yes	0.6				
2	Floor Area						
	A	Building Footprint (m ²)	3349		5,024		
		Number of Floors/Storeys	9				
		Protected Openings (1 hr)	Yes				
		Area of structure considered (m ²)					
F	Base fire flow without reductions			9,000			
Reductions or Surcharges							
3	Occupancy hazard reduction or surcharge		FUS Table 3	Reduction/Surcharge			
	(1)	Non-combustible		-25%	-15%		
		Limited combustible	Yes	-15%			
		Combustible		0%			
		Free burning		15%			
Rapid burning			25%				
4	Sprinkler Reduction		FUS Table 4	Reduction			
	(2)	Adequately Designed System (NFPA 13)	Yes	-30%	-30%		
		Standard Water Supply	Yes	-10%	-10%		
		Fully Supervised System	Yes	-10%	-10%		
		Cumulative Sub-Total			-50%		
Area of Sprinklered Coverage (m²)		22605	75%				
		Cumulative Total		-37%			
5	Exposure Surcharge		FUS Table 5	Surcharge			
	(3)	North Side	>30m		0%		
		East Side	10.1 - 20 m		15%		
		South Side	10.1 - 20 m		15%		
		West Side	10.1 - 20 m		15%		
		Cumulative Total		45%			
Results							
6	(1) + (2) + (3)	Total Required Fire Flow, rounded to nearest 1000L/min			L/min	8,000	
		(2,000 L/min < Fire Flow < 45,000 L/min)			or	L/s	133
					or	USGPM	2,114

FUS - Fire Flow Calculations

As per 2020 Fire Underwriter's Survey Guidelines



Engineers, Planners & Landscape Architects

Novatech Project #: 121009
 Project Name: 1500 Merivale Road
 Date: 11/23/2022
 Input By: Curtis Ferguson, E.I.T.
 Reviewed By: Anthony Mestwarp, P.Eng

Legend

Input by User
 No Information or Input Required

Building Description: Phase 6 - 9 Storey Midrise
 Type I - Fire resistive construction (2 hrs)

Step		Choose		Value Used	Total Fire Flow (L/min)		
Base Fire Flow							
1	Construction Material			Multiplier			
	Coefficient related to type of construction C	Type V - Wood frame		1.5	0.6		
		Type IV - Mass Timber		Varies			
		Type III - Ordinary construction		1			
		Type II - Non-combustible construction		0.8			
Type I - Fire resistive construction (2 hrs)		Yes	0.6				
2	Floor Area						
	A	Building Footprint (m ²)	1752		2,628		
		Number of Floors/Storeys	9				
		Protected Openings (1 hr)	Yes				
		Area of structure considered (m ²)					
F	Base fire flow without reductions			7,000			
F = 220 C (A)^{0.5}							
Reductions or Surcharges							
3	Occupancy hazard reduction or surcharge		FUS Table 3	Reduction/Surcharge			
	(1)	Non-combustible		-25%	-15%		
		Limited combustible	Yes	-15%			
		Combustible		0%			
		Free burning		15%			
Rapid burning			25%				
4	Sprinkler Reduction		FUS Table 4	Reduction			
	(2)	Adequately Designed System (NFPA 13)	Yes	-30%	-30%		
		Standard Water Supply	Yes	-10%	-10%		
		Fully Supervised System	Yes	-10%	-10%		
		Cumulative Sub-Total			-50%		
Area of Sprinklered Coverage (m²)		11826	75%				
Cumulative Total				-38%			
5	Exposure Surcharge		FUS Table 5	Surcharge			
	(3)	North Side	>30m		0%		
		East Side	3.1 - 10 m		20%		
		South Side	Firewall-2hr		0%		
		West Side	0 - 3 m		25%		
Cumulative Total				45%			
Results							
6	(1) + (2) + (3)	Total Required Fire Flow, rounded to nearest 1000L/min			L/min	6,000	
		(2,000 L/min < Fire Flow < 45,000 L/min)			or	L/s	100
					or	USGPM	1,585

FUS - Fire Flow Calculations

As per 2020 Fire Underwriter's Survey Guidelines



Engineers, Planners & Landscape Architects

Novatech Project #: 121009
 Project Name: 1500 Merivale Road
 Date: 11/22/2022
 Input By: Curtis Ferguson, E.I.T.
 Reviewed By: Anthony Mestwarp, P.Eng

Legend
 Input by User
 No Information or Input Required

Building Description: Phase 1 - 10 Storey Building
 Type I - Fire resistive construction (2 hrs)

Step		Choose		Value Used	Total Fire Flow (L/min)		
Base Fire Flow							
1	Construction Material			Multiplier			
	Coefficient related to type of construction C	Type V - Wood frame		1.5	0.6		
		Type IV - Mass Timber		Varies			
		Type III - Ordinary construction		1			
		Type II - Non-combustible construction		0.8			
Type I - Fire resistive construction (2 hrs)		Yes	0.6				
2	Floor Area						
	A	Building Footprint (m ²)	1395		2,093		
		Number of Floors/Storeys	10				
		Protected Openings (1 hr)	Yes				
		Area of structure considered (m ²)					
F	Base fire flow without reductions			6,000			
F = 220 C (A)^{0.5}							
Reductions or Surcharges							
3	Occupancy hazard reduction or surcharge		FUS Table 3	Reduction/Surcharge			
	(1)	Non-combustible		-25%	-15%		
		Limited combustible	Yes	-15%			
		Combustible		0%			
		Free burning		15%			
Rapid burning			25%				
4	Sprinkler Reduction		FUS Table 4	Reduction			
	(2)	Adequately Designed System (NFPA 13)	Yes	-30%	-30%		
		Standard Water Supply	Yes	-10%	-10%		
		Fully Supervised System	Yes	-10%	-10%		
		Cumulative Sub-Total			-50%		
Area of Sprinklered Coverage (m ²)		10500	75%				
Cumulative Total				-38%			
5	Exposure Surcharge		FUS Table 5	Surcharge			
	(3)	North Side	>30m		0%		
		East Side	>30m		0%		
		South Side	20.1 - 30 m		10%		
		West Side	>30m		0%		
Cumulative Total			10%				
Results							
6	(1) + (2) + (3)	Total Required Fire Flow, rounded to nearest 1000L/min			L/min	4,000	
		(2,000 L/min < Fire Flow < 45,000 L/min)			or	L/s	67
					or	USGPM	1,057

FUS - Fire Flow Calculations

As per 2020 Fire Underwriter's Survey Guidelines



Engineers, Planners & Landscape Architects

Novatech Project #: 121009
 Project Name: 1500 Merivale Road
 Date: 11/22/2022
 Input By: Curtis Ferguson, E.I.T.
 Reviewed By: Anthony Mestwarp, P.Eng

Legend	Input by User
	No Information or Input Required

Building Description: Phase 2 - 9 Storey Building
 Type I - Fire resistive construction (2 hrs)

Step		Choose		Value Used	Total Fire Flow (L/min)		
Base Fire Flow							
1	Construction Material			Multiplier			
	Coefficient related to type of construction C	Type V - Wood frame		1.5	0.6		
		Type IV - Mass Timber		Varies			
		Type III - Ordinary construction		1			
		Type II - Non-combustible construction		0.8			
Type I - Fire resistive construction (2 hrs)		Yes	0.6				
2	Floor Area						
	A	Building Footprint (m ²)	2431		3,647		
		Number of Floors/Storeys	9				
		Protected Openings (1 hr)	Yes				
		Area of structure considered (m ²)					
F	Base fire flow without reductions			8,000			
Reductions or Surcharges							
3	Occupancy hazard reduction or surcharge		FUS Table 3	Reduction/Surcharge			
	(1)	Non-combustible		-25%	-15%		
		Limited combustible	Yes	-15%			
		Combustible		0%			
		Free burning		15%			
Rapid burning			25%				
4	Sprinkler Reduction		FUS Table 4	Reduction			
	(2)	Adequately Designed System (NFPA 13)	Yes	-30%	-30%		
		Standard Water Supply	Yes	-10%	-10%		
		Fully Supervised System	Yes	-10%	-10%		
		Cumulative Sub-Total			-50%		
Area of Sprinklered Coverage (m²)		16409	75%				
Cumulative Total				-37%			
5	Exposure Surcharge		FUS Table 5	Surcharge			
	(3)	North Side	20.1 - 30 m		10%		
		East Side	>30m		0%		
		South Side	>30m		0%		
		West Side	Firewall-2hr		0%		
Cumulative Total			10%				
Results							
6	(1) + (2) + (3)	Total Required Fire Flow, rounded to nearest 1000L/min			L/min	5,000	
		(2,000 L/min < Fire Flow < 45,000 L/min)			or	L/s	83
					or	USGPM	1,321

FUS - Fire Flow Calculations

As per 2020 Fire Underwriter's Survey Guidelines



Engineers, Planners & Landscape Architects

Novatech Project #: 121009
 Project Name: 1500 Merivale Road
 Date: 11/23/2022
 Input By: Curtis Ferguson, E.I.T.
 Reviewed By: Anthony Mestwarp, P.Eng

Legend
 Input by User
 No Information or Input Required

Building Description: Phase 3 - 11 Storey Tower
 Type I - Fire resistive construction (2 hrs)

Step		Choose		Value Used	Total Fire Flow (L/min)		
Base Fire Flow							
1	Construction Material			Multiplier			
	Coefficient related to type of construction C	Type V - Wood frame		1.5	0.6		
		Type IV - Mass Timber		Varies			
		Type III - Ordinary construction		1			
		Type II - Non-combustible construction		0.8			
Type I - Fire resistive construction (2 hrs)		Yes	0.6				
2	Floor Area						
	A	Building Footprint (m ²)	763		1,145		
		Number of Floors/Storeys	11				
		Protected Openings (1 hr)	Yes				
		Area of structure considered (m ²)					
F	Base fire flow without reductions			4,000			
		F = 220 C (A)^{0.5}					
Reductions or Surcharges							
3	Occupancy hazard reduction or surcharge		FUS Table 3	Reduction/Surcharge			
	(1)	Non-combustible		-25%	-15%		
		Limited combustible	Yes	-15%			
		Combustible		0%			
		Free burning		15%			
Rapid burning			25%				
		Cumulative Sub-Total		-15%			
4	Sprinkler Reduction		FUS Table 4	Reduction			
	(2)	Adequately Designed System (NFPA 13)	Yes	-30%	-30%		
		Standard Water Supply	Yes	-10%	-10%		
		Fully Supervised System	Yes	-10%	-10%		
		Cumulative Sub-Total		-50%			
Area of Sprinklered Coverage (m²)		6295	75%				
		Cumulative Total		-38%			
5	Exposure Surcharge		FUS Table 5	Surcharge			
	(3)	North Side	20.1 - 30 m		10%		
		East Side	Firewall-2hr		0%		
		South Side	>30m		0%		
		West Side	Firewall-2hr		0%		
Cumulative Total		10%					
Results							
6	(1) + (2) + (3)	Total Required Fire Flow, rounded to nearest 1000L/min			L/min	2,000	
		(2,000 L/min < Fire Flow < 45,000 L/min)			or	L/s	33
					or	USGPM	528

FUS - Fire Flow Calculations

As per 2020 Fire Underwriter's Survey Guidelines



Engineers, Planners & Landscape Architects

Novatech Project #: 121009
 Project Name: 1500 Merivale Road
 Date: 11/23/2022
 Input By: Curtis Ferguson, E.I.T.
 Reviewed By: Anthony Mestwarp, P.Eng

Legend
 Input by User
 No Information or Input Required

Building Description: Phase 7 - 9 Storey Midrise
 Type I - Fire resistive construction (2 hrs)

Step		Choose		Value Used	Total Fire Flow (L/min)		
Base Fire Flow							
1	Construction Material			Multiplier			
	Coefficient related to type of construction C	Type V - Wood frame		1.5	0.6		
		Type IV - Mass Timber		Varies			
		Type III - Ordinary construction		1			
		Type II - Non-combustible construction		0.8			
Type I - Fire resistive construction (2 hrs)		Yes	0.6				
2	Floor Area						
	A	Building Footprint (m ²)	1920		2,880		
		Number of Floors/Storeys	9				
		Protected Openings (1 hr)	Yes				
		Area of structure considered (m ²)					
F	Base fire flow without reductions			7,000			
Reductions or Surcharges							
3	Occupancy hazard reduction or surcharge		FUS Table 3	Reduction/Surcharge			
	(1)	Non-combustible		-25%	-15%		
		Limited combustible	Yes	-15%			
		Combustible		0%			
		Free burning		15%			
Rapid burning			25%				
4	Sprinkler Reduction		FUS Table 4	Reduction			
	(2)	Adequately Designed System (NFPA 13)	Yes	-30%	-30%		
		Standard Water Supply	Yes	-10%	-10%		
		Fully Supervised System	Yes	-10%	-10%		
		Cumulative Sub-Total			-50%		
Area of Sprinklered Coverage (m²)		12960	75%				
Cumulative Total				-38%			
5	Exposure Surcharge		FUS Table 5	Surcharge			
	(3)	North Side	Firewall-2hr		0%		
		East Side	>30m		0%		
		South Side	Firewall-2hr		0%		
		West Side	10.1 - 20 m		15%		
Cumulative Total				15%			
Results							
6	(1) + (2) + (3)	Total Required Fire Flow, rounded to nearest 1000L/min			L/min	5,000	
		(2,000 L/min < Fire Flow < 45,000 L/min)			or	L/s	83
					or	USGPM	1,321

FUS - Fire Flow Calculations

As per 2020 Fire Underwriter's Survey Guidelines



Engineers, Planners & Landscape Architects

Novatech Project #: 121009
 Project Name: 1500 Merivale Road
 Date: 11/23/2022
 Input By: Curtis Ferguson, E.I.T.
 Reviewed By: Anthony Mestwarp, P.Eng

Legend
 Input by User
 No Information or Input Required

Building Description: Phase 8 - 9 Storey Midrise
 Type I - Fire resistive construction (2 hrs)

Step		Choose		Value Used	Total Fire Flow (L/min)		
Base Fire Flow							
1	Construction Material			Multiplier			
	Coefficient related to type of construction C	Type V - Wood frame		1.5	0.6		
		Type IV - Mass Timber		Varies			
		Type III - Ordinary construction		1			
		Type II - Non-combustible construction		0.8			
Type I - Fire resistive construction (2 hrs)		Yes	0.6				
2	Floor Area						
	A	Building Footprint (m ²)	1910		2,865		
		Number of Floors/Storeys	9				
		Protected Openings (1 hr)	Yes				
		Area of structure considered (m ²)					
F	Base fire flow without reductions			7,000			
Reductions or Surcharges							
3	Occupancy hazard reduction or surcharge		FUS Table 3	Reduction/Surcharge			
	(1)	Non-combustible		-25%	-15%		
		Limited combustible	Yes	-15%			
		Combustible		0%			
		Free burning		15%			
Rapid burning			25%				
4	Sprinkler Reduction		FUS Table 4	Reduction			
	(2)	Adequately Designed System (NFPA 13)	Yes	-30%	-30%		
		Standard Water Supply	Yes	-10%	-10%		
		Fully Supervised System	Yes	-10%	-10%		
		Cumulative Sub-Total			-50%		
Area of Sprinklered Coverage (m²)		12893	75%				
Cumulative Total				-38%			
5	Exposure Surcharge		FUS Table 5	Surcharge			
	(3)	North Side	Firewall-2hr		0%		
		East Side	20.1 - 30 m		10%		
		South Side	20.1 - 30 m		10%		
		West Side	10.1 - 20 m		15%		
Cumulative Total				35%			
Results							
6	(1) + (2) + (3)	Total Required Fire Flow, rounded to nearest 1000L/min			L/min	6,000	
		(2,000 L/min < Fire Flow < 45,000 L/min)			or	L/s	100
					or	USGPM	1,585

FUS - Fire Flow Calculations

As per 2020 Fire Underwriter's Survey Guidelines



Engineers, Planners & Landscape Architects

Novatech Project #: 121009
 Project Name: 1500 Merivale Road
 Date: 11/24/2022
 Input By: Curtis Ferguson, E.I.T.
 Reviewed By: Anthony Mestwarp, P.Eng

Legend
 Input by User
 No Information or Input Required

Building Description: Phase 9 - 9 Storey Midrise
 Type I - Fire resistive construction (2 hrs)

Step		Choose		Value Used	Total Fire Flow (L/min)		
Base Fire Flow							
1	Construction Material			Multiplier			
	Coefficient related to type of construction C	Type V - Wood frame		1.5	0.6		
		Type IV - Mass Timber		Varies			
		Type III - Ordinary construction		1			
		Type II - Non-combustible construction		0.8			
Type I - Fire resistive construction (2 hrs)		Yes	0.6				
2	Floor Area						
	A	Building Footprint (m ²)	2024		3,036		
		Number of Floors/Storeys	9				
		Protected Openings (1 hr)	Yes				
		Area of structure considered (m ²)					
F	Base fire flow without reductions			7,000			
		F = 220 C (A)^{0.5}					
Reductions or Surcharges							
3	Occupancy hazard reduction or surcharge		FUS Table 3	Reduction/Surcharge			
	(1)	Non-combustible		-25%	-15%		
		Limited combustible	Yes	-15%			
		Combustible		0%			
		Free burning		15%			
Rapid burning			25%				
4	Sprinkler Reduction		FUS Table 4	Reduction			
	(2)	Adequately Designed System (NFPA 13)	Yes	-30%	-30%		
		Standard Water Supply	Yes	-10%	-10%		
		Fully Supervised System	Yes	-10%	-10%		
		Cumulative Sub-Total			-50%		
Area of Sprinklered Coverage (m²)		13750	75%				
		Cumulative Total		-38%			
5	Exposure Surcharge		FUS Table 5	Surcharge			
	(3)	North Side	10.1 - 20 m		15%		
		East Side	10.1 - 20 m		15%		
		South Side	20.1 - 30 m		10%		
		West Side	>30m		0%		
		Cumulative Total		40%			
Results							
6	(1) + (2) + (3)	Total Required Fire Flow, rounded to nearest 1000L/min			L/min	6,000	
		(2,000 L/min < Fire Flow < 45,000 L/min)			or	L/s	100
					or	USGPM	1,585

FUS - Fire Flow Calculations

As per 2020 Fire Underwriter's Survey Guidelines



Engineers, Planners & Landscape Architects

Novatech Project #: 121009
 Project Name: 1500 Merivale Road
 Date: 11/23/2022
 Input By: Curtis Ferguson, E.I.T.
 Reviewed By: Anthony Mestwarp, P.Eng

Legend

Input by User
 No Information or Input Required

Building Description: Phase 10 - 9 Storey Midrise & 11 Storey Tower
 Type I - Fire resistive construction (2 hrs)

Step		Choose		Value Used	Total Fire Flow (L/min)	
Base Fire Flow						
1	Construction Material			Multiplier		
	Coefficient related to type of construction C	Type V - Wood frame		1.5	0.6	
		Type IV - Mass Timber		Varies		
		Type III - Ordinary construction		1		
		Type II - Non-combustible construction		0.8		
Type I - Fire resistive construction (2 hrs)		Yes	0.6			
2	Floor Area					
	A	Podium Level Footprint (m ²)	3263			
		Total Floors/Storeys (Podium)	9			
		Tower Footprint (m ²)	873			
		Total Floors/Storeys (Tower)	2			
		Protected Openings (1 hr)	Yes			
	A, Total Effective Floor Area (m ²)			4,895		
F	Base fire flow without reductions					
	F = 220 C (A)^{0.5}			9,000		
Reductions or Surcharges						
3	Occupancy hazard reduction or surcharge		FUS Table 3	Reduction/Surcharge		
	(1)	Non-combustible		-25%	-15%	
		Limited combustible	Yes	-15%		
		Combustible		0%		
		Free burning		15%		
Rapid burning			25%			
4	Sprinkler Reduction		FUS Table 4	Reduction		
	(2)	Adequately Designed System (NFPA 13)	Yes	-30%	-30%	
		Standard Water Supply	Yes	-10%	-10%	
		Fully Supervised System	Yes	-10%	-10%	
		Cumulative Sub-Total			-50%	
		Area of Sprinklered Coverage (m²)	23335	75%		
Cumulative Total			-38%			
5	Exposure Surcharge per		FUS Table 5	Surcharge		
	(3)	North Side	20.1 - 30 m		10%	
		East Side	>30m		0%	
		South Side	10.1 - 20 m		15%	
		West Side	>30m		0%	
Cumulative Total			25%			
Results						
6	(1) + (2) + (3)	Total Required Fire Flow, rounded to nearest 1000L/min			L/min	7,000
		(2,000 L/min < Fire Flow < 45,000 L/min)			or	L/s
					or	USGPM
7	Storage Volume	Required Duration of Fire Flow (hours)			Hours	2
		Required Volume of Fire Flow (m ³)			m ³	840

FUS - Fire Flow Calculations

As per 2020 Fire Underwriter's Survey Guidelines



Engineers, Planners & Landscape Architects

Novatech Project #: 121009
 Project Name: 1500 Merivale Road
 Date: 11/24/2022
 Input By: Curtis Ferguson, E.I.T.
 Reviewed By: Anthony Mestwarp, P.Eng

Legend	Input by User
	No Information or Input Required



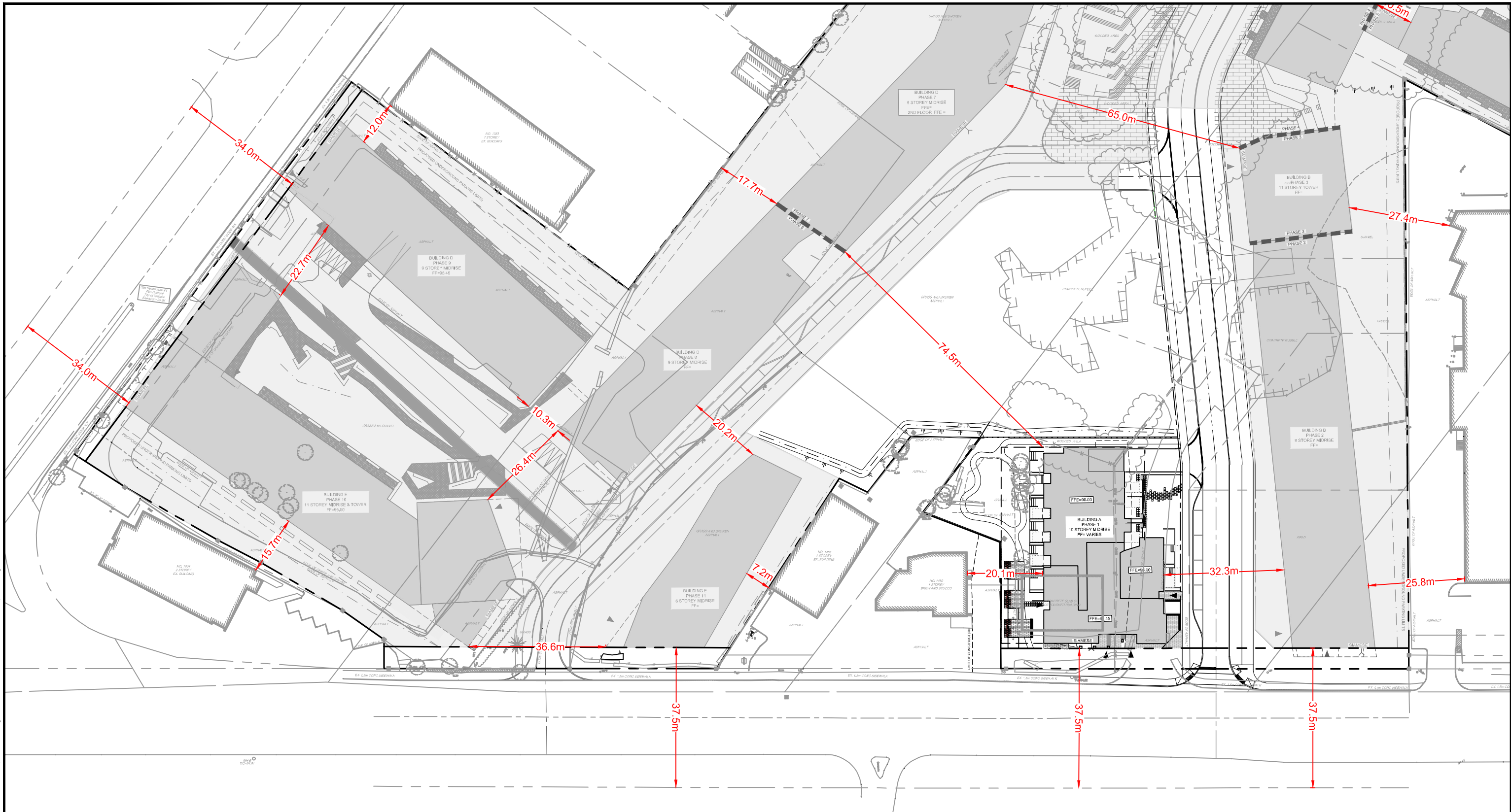

Building Description: Phase 11 - 6 Storey Midrise
 Type I - Fire resistive construction (2 hrs)

Step		Choose		Value Used	Total Fire Flow (L/min)		
Base Fire Flow							
1	Construction Material			Multiplier			
	Coefficient related to type of construction C	Type V - Wood frame		1.5	0.6		
		Type IV - Mass Timber		Varies			
		Type III - Ordinary construction		1			
		Type II - Non-combustible construction		0.8			
Type I - Fire resistive construction (2 hrs)		Yes	0.6				
2	Floor Area						
	A	Building Footprint (m ²)	1125		1,688		
		Number of Floors/Storeys	6				
		Protected Openings (1 hr)	Yes				
		Area of structure considered (m ²)					
F	Base fire flow without reductions			5,000			
		F = 220 C (A)^{0.5}					
Reductions or Surcharges							
3	Occupancy hazard reduction or surcharge		FUS Table 3	Reduction/Surcharge			
	(1)	Non-combustible		-25%	-15%		
		Limited combustible	Yes	-15%			
		Combustible		0%			
		Free burning		15%			
Rapid burning			25%				
4	Sprinkler Reduction		FUS Table 4	Reduction			
	(2)	Adequately Designed System (NFPA 13)	Yes	-30%	-30%		
		Standard Water Supply	Yes	-10%	-10%		
		Fully Supervised System	Yes	-10%	-10%		
		Cumulative Sub-Total			-50%		
Area of Sprinklered Coverage (m²)		5063	75%				
		Cumulative Total		-38%			
5	Exposure Surcharge		FUS Table 5	Surcharge			
	(3)	North Side	>30m		0%		
		East Side	3.1 - 10 m		20%		
		South Side	>30m		0%		
		West Side	20.1 - 30 m		10%		
		Cumulative Total		30%			
Results							
6	(1) + (2) + (3)	Total Required Fire Flow, rounded to nearest 1000L/min			L/min	4,000	
		(2,000 L/min < Fire Flow < 45,000 L/min)			or	L/s	67
					or	USGPM	1,057

M:\2021\1121009\CAD\Design\Figures\Hydraulic\121009 - FUS Separation.dwg, FUS SEP-1, Nov 25, 2022 - 2:28pm, cferguson



LEGEND

-  PROPERTY LINE
-  PROPOSED TACTILE INDICATOR
-  PROPOSED ENTRANCE
-  PROPOSED DEPRESSED CURB

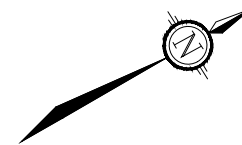

NOVATECH

Engineers, Planners & Landscape Architects
 Suite 200, 240 Michael Cowpland Drive
 Ottawa, Ontario, Canada K2M 1P6

Telephone (613) 254-9643
 Facsimile (613) 254-5867
 Website www.novatech-eng.com

CITY OF OTTAWA
 1500 MERIVALE ROAD

FUS SEPARATION

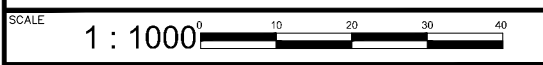



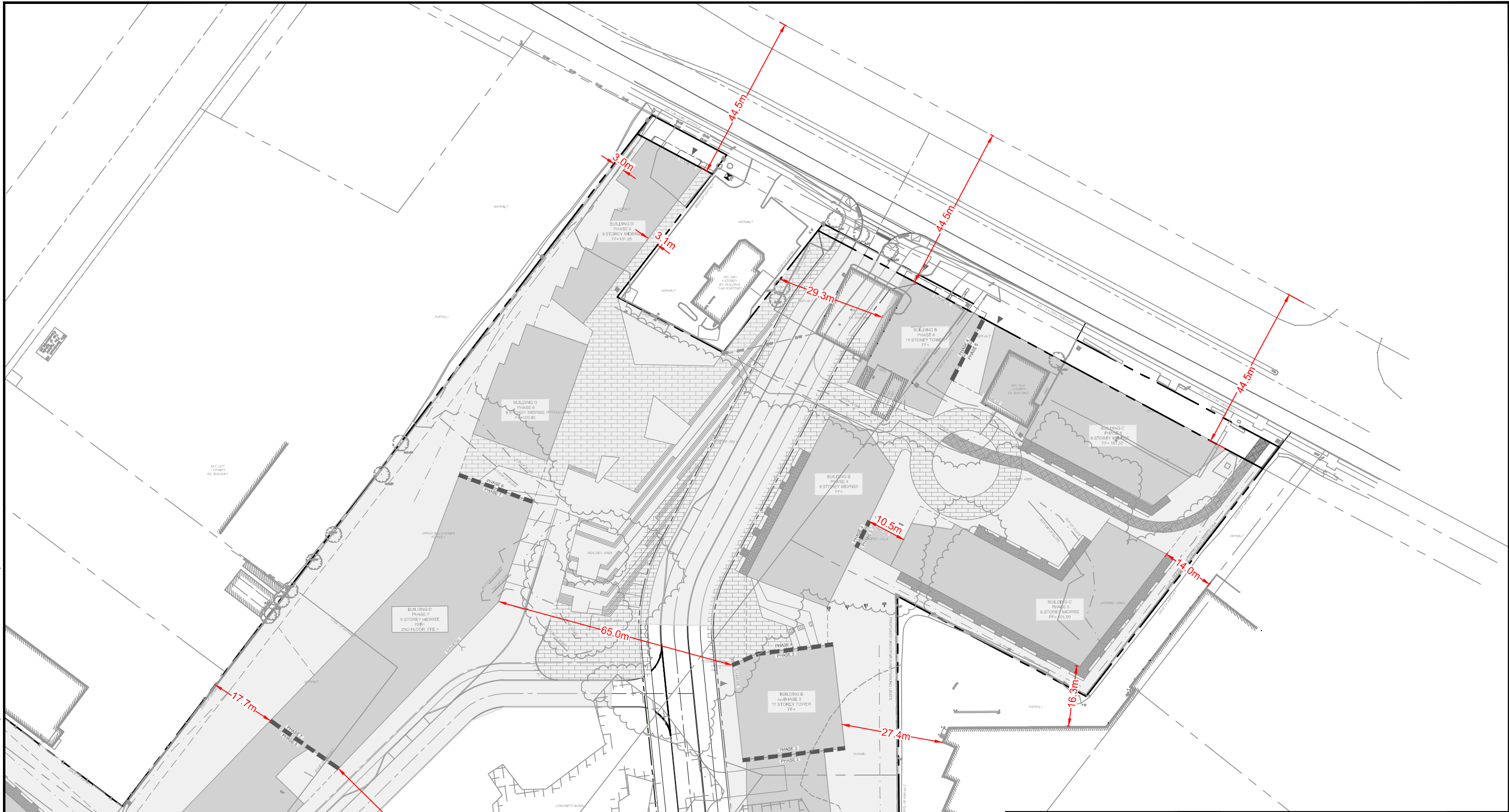

DATE	JOB	FIGURE
NOV 2022	121009	FUS-1

M:\2021\1121009\CAD\Design\Figures\Hydraulic\121009 - FUS Separation.dwg, FUS SEP-2, Nov 25, 2022 - 2:28pm, cferguson



LEGEND

-  PROPERTY LINE
-  PROPOSED TACTILE INDICATOR
-  PROPOSED ENTRANCE
-  PROPOSED DEPRESSED CURB

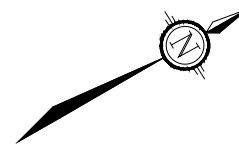

NOVATECH

Engineers, Planners & Landscape Architects
 Suite 200, 240 Michael Cowpland Drive
 Ottawa, Ontario, Canada K2M 1P6

Telephone (613) 254-9643
 Facsimile (613) 254-5867
 Website www.novatech-eng.com

CITY OF OTTAWA
 1500 MERIVALE ROAD

FUS SEPARATION

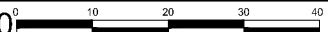
SCALE 1 : 1000 

DATE NOV 2022 JOB 121009 FIGURE FUS-1

\\novatech2018\novatech\2022\11\12\1009\CAD\Design\Figures\Hydraulic\121009 - COVERAGE PLAN.dwg, COV PLAN 1, Nov 25, 2022 - 4:08pm, cferguson

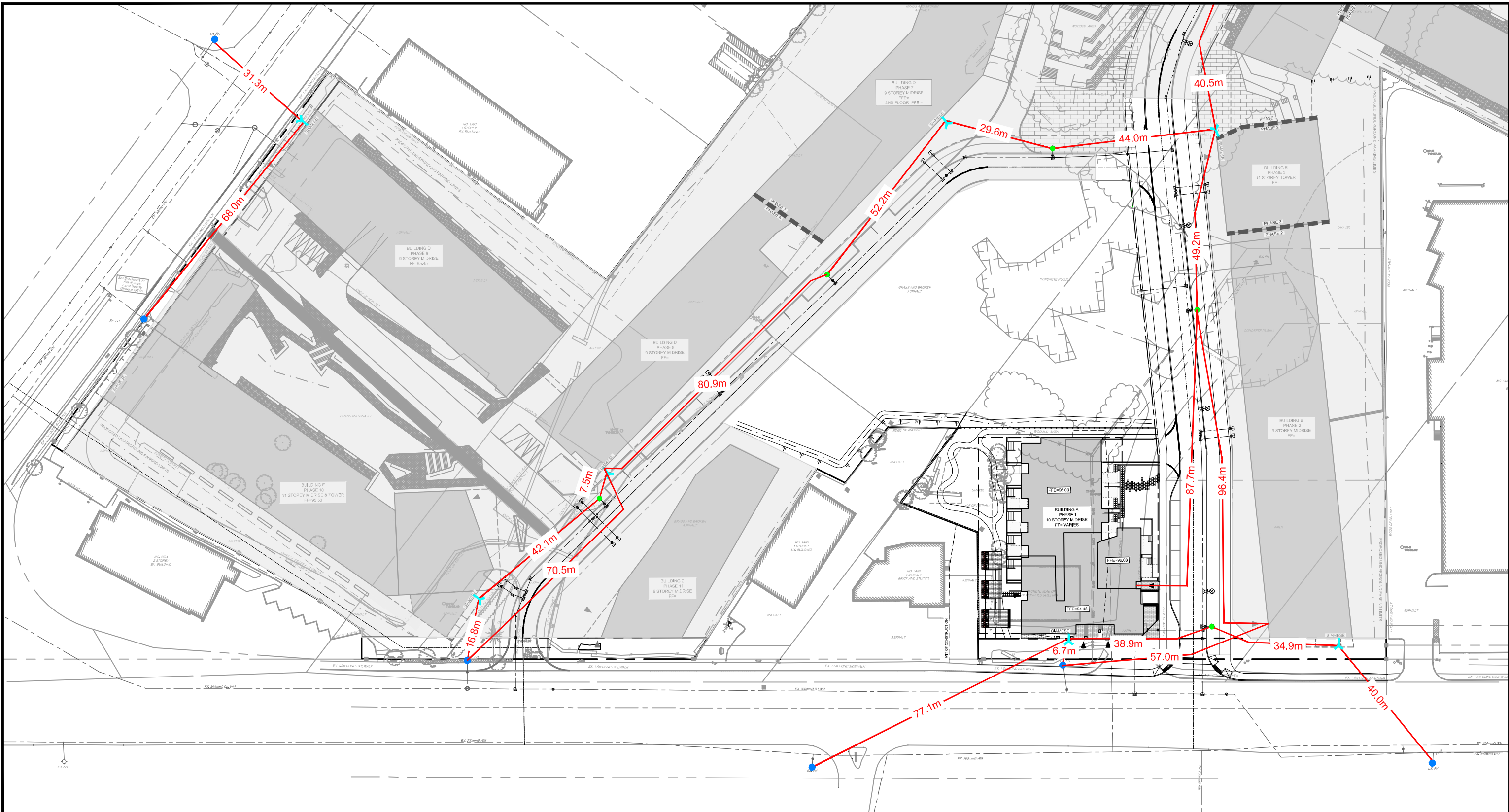

LEGEND

- PROPERTY LINE
- PROPOSED SIAMESE CONNECTION
- EXISTING CLASS AA HYDRANT
- PROPOSED HYDRANT
- DISTANCE FROM HYDRANT TO SIAMESE CONNECTION/ BUILDING ENTRANCE

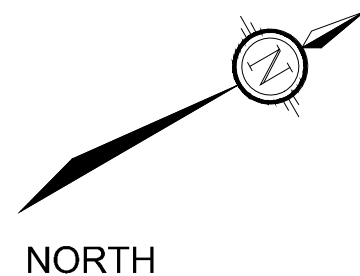

NOVATECH
 Engineers, Planners & Landscape Architects
 Suite 200, 240 Michael Cowpland Drive
 Ottawa, Ontario, Canada K2M 1P6

Telephone (613) 254-9643
 Facsimile (613) 254-5867
 Website www.novatech-eng.com

CITY OF OTTAWA
 1500 MERIVALE ROAD



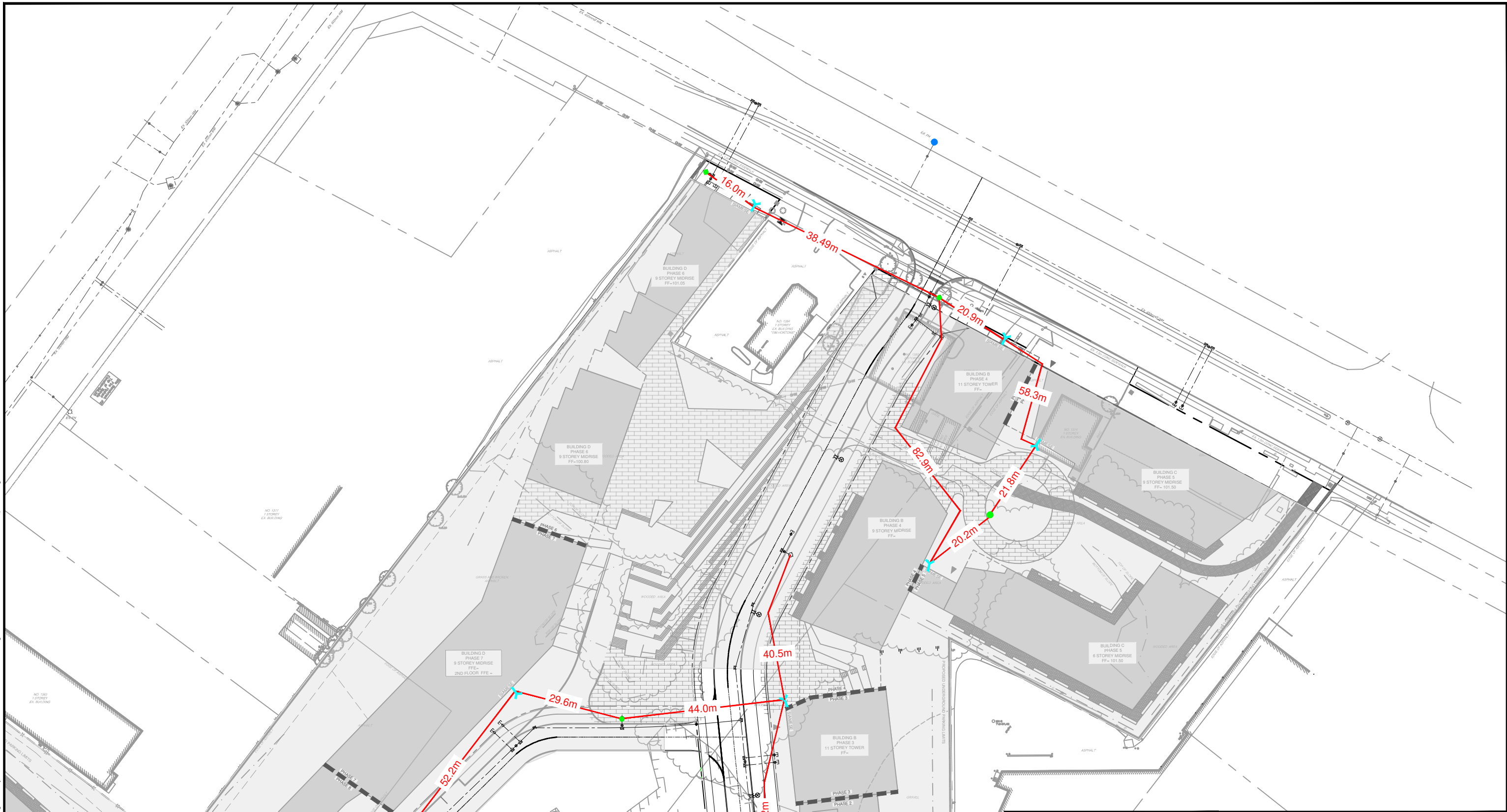

COVERAGE PLAN

SCALE	1 : 1000	
DATE	NOV 2022	JOB 121009
FIGURE	COV1	

\\novatech2018\novatech\2021\121009\CAD\Design\Hydraulic\121009 - COVERAGE PLAN.dwg, COV PLAN 2, Nov 25, 2022 - 4:08pm, cferguson



LEGEND

-  PROPERTY LINE
-  PROPOSED SIAMESE CONNECTION
-  EXISTING CLASS AA HYDRANT
-  PROPOSED HYDRANT
-  DISTANCE FROM HYDRANT TO SIAMESE CONNECTION/ BUILDING ENTRANCE

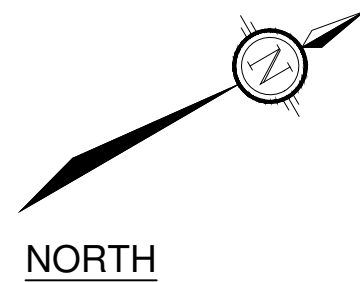

NOVATECH

Engineers, Planners & Landscape Architects
Suite 200, 240 Michael Cowpland Drive
Ottawa, Ontario, Canada K2M 1P6

Telephone (613) 254-9643
Facsimile (613) 254-5867
Website www.novatech-eng.com

CITY OF OTTAWA
1500 MERIVALE ROAD

COVERAGE PLAN

SCALE 1 : 1000 

DATE NOV 2022 JOB 121009 FIGURE COV2

From: Nathan Godlovitch <ngodlovitch@evoqarchitecture.com>

Sent: Wednesday, May 11, 2022 2:03 PM

To: Curtis Ferguson <c.ferguson@novatech-eng.com>; Sayeh Jolan <sjolan@evoqarchitecture.com>; Christine Hannouche <channouche@evoqarchitecture.com>

Cc: Anthony Mestwarp <a.mestwarp@novatech-eng.com>

Subject: RE: 121009 - 1500 Merivale Rd - Detail Confirmation

Hi Curtis

Poured concrete construction, Modified Fire Resistive (2h).

There will be firewalls between adjacent phases with horizontal exits. I will check parking extent... I think we are awaiting an understanding with the city before finalizing but I will verify.

Regards,

Nathan

Nathan Godlovitch, Arch OAQ

ARCHITECTE, COLLABORATEUR
ARCHITECT, ASSOCIATE

1435, RUE ST-ALEXANDRE, BUREAU 1000
MONTRÉAL, QC H3A 2G4
T. 514.393.9490 / 477
C. 514.270.3071

EVOQ ARCHITECTURE
ANCIENNEMENT / FORMERLY FGMDA

AVIS DE CONFIDENTIALITÉ: Ce courriel peut contenir de l'information confidentielle. Nous vous demandons de le supprimer immédiatement si vous n'en êtes pas le destinataire.
CONFIDENTIALITY NOTICE: This email may contain confidential information. If you are not the intended recipient, please delete immediately.

Pensez avant d'imprimer!  Think before you print!

AVIS DE CONFIDENTIALITÉ : Ce courriel peut contenir de l'information privilégiée et confidentielle.
Nous vous demandons de le détruire immédiatement si vous n'êtes pas le destinataire.
CONFIDENTIALITY NOTICE: This email may contain information that is privileged and confidential.
Please delete immediately if you are not the intended recipient.

From: Curtis Ferguson <c.ferguson@novatech-eng.com>

Sent: May 11, 2022 1:45 PM

To: Nathan Godlovitch <ngodlovitch@evoqarchitecture.com>; Sayeh Jolan <sjolan@evoqarchitecture.com>; Christine Hannouche <channouche@evoqarchitecture.com>

Cc: Anthony Mestwarp <a.mestwarp@novatech-eng.com>

Subject: RE: 121009 - 1500 Merivale Rd - Detail Confirmation

Nathan,

Please ignore questions about Occupancy Hazard Reduction or Surcharge below.

Instead please confirm;

- Construction Material
 - o Modified Fire Resistive Construction (2 hrs) or
 - o Fire Resistive Construction (>3hrs)

Apologizes for the confusion.

Curtis Ferguson, B.A.Sc., E.I.T. | Land Development

NOVATECH Engineers, Planners & Landscape Architects

240 Michael Cowpland Drive, Suite 200, Ottawa, ON, K2M 1P6 | Tel: 613.254.9643 EXT: 331 | Fax: 613.254.5867

The information contained in this email message is confidential and is for exclusive use of the addressee.

Montreal, March 21, 2024

Curtis Ferguson
Novatech
240 Michael Cowpland Dr., Suite 200
OTTAWA, ON, K2M 1P6

RE: 1500 Merivale – Phase 1
EVOQ Project Ref : 9426-20-00

Curtis,

This letter is to certify that the project 1500 Merivale, Phase 1 and all subsequent phases as currently anticipated, will be built as *Fire-resistive construction (Type 1)* with structural elements being built of 2-hour rated poured-in-place concrete and minor elements in protected structural steel satisfying the conditions below:

As per the FUS, a building is considered to be of Fire-resistive construction (Type I) when all structural elements, walls, arches, floors, and roofs are constructed with a minimum 2-hour fire resistance rating, and all materials used in the construction of the structural elements, walls, arches, floors, and roofs are constructed with non-combustible materials.

Yours truly,
EVOQ ARCHITECTURE INC.

Nathan Godlovitch, OAQ

Cc: Greg MacDonald, *Novatech*
Anthony Mertwarp, *Novatech*
Vincent Denomme, *Claridge Homes*

ARCHITECTS
PRINCIPALS
DIRECTORS
ALAIN FOURNIER
JULIA GERSOVITZ, O.C.
ROSANNE MOSS
GEORGES DROLET
GIOVANNI DIODATI
DIMA COOK
ERIC MOUTQUIN
SAMI TANNOURY

ARCHITECTS
ASSOCIATES
DIRECTORS
LENA BUCHINGER
ROXANNE GAUTHIER
ERIC STEIN

ASSOCIATES
MATTEO CENDAMO
JAMES CURTISS
LISE DESJARDINS
G. CATHERINE FANOUS
NATHAN GODLOVITCH
MARIANNE LEROUX
SYBIL McKENNA
NEIL McNULTY
GILLES PRUD'HOMME
MARIE-FRANCE TURGEON

From: Nathan Godlovitch <ngodlovitch@evoqarchitecture.com>
Sent: Wednesday, November 30, 2022 11:36 AM
To: Anthony Mestwarp <a.mestwarp@novatech-eng.com>
Cc: Sayeh Jolan <sjolan@evoqarchitecture.com>; Curtis Ferguson <c.ferguson@novatech-eng.com>
Subject: RE: 121009 - 1500 Merivale - FUS Email Confirmation

Hi Anthony

Responses below:

I do not have the Criteria by which the water supply is considered 'standard'. Building is fully sprinklered an has 121 residential units and 153 m2 commercial. No Pool anticipated.

Regards,

Nathan

From: Anthony Mestwarp <a.mestwarp@novatech-eng.com>
Sent: November 30, 2022 11:04 AM
To: Nathan Godlovitch <ngodlovitch@evoqarchitecture.com>
Cc: Sayeh Jolan <sjolan@evoqarchitecture.com>; Curtis Ferguson <c.ferguson@novatech-eng.com>
Subject: RE: 121009 - 1500 Merivale - FUS Email Confirmation

Hi Nathan,

I was unable to find your response to the below email. Can you please reconfirm regarding the updated design if the below sprinkler criteria applies to the revised site.

Thanks,

Anthony Mestwarp, P.Eng., Project Engineer | Land Development Engineering

NOVATECH Engineers, Planners & Landscape Architects

240 Michael Cowpland Drive, Suite 200, Ottawa, ON, K2M 1P6 | Tel: 613.254.9643 Ext. 216 | Fax: 613.254.5867

The information contained in this email message is confidential and is for exclusive use of the addressee.

From: Curtis Ferguson <c.ferguson@novatech-eng.com>

Sent: Monday, July 18, 2022 10:28 AM

To: Nathan Godlovitch <ngodlovitch@evoqarchitecture.com>

Cc: Sayeh Jolan <sjolan@evoqarchitecture.com>; Anthony Mestwarp <a.mestwarp@novatech-eng.com>

Subject: 121009 - 1500 Merivale - FUS Email Confirmation

Nathan,

I'm aware we've had this conversation over the phone previously but we need email records confirming the following;

Please clarify below for fire flow calculations:

- Sprinkler Reduction;
 - o Adequately Designed System (NFPA 13) – **Y OR N YES**
 - o Standard Water Supply – **Y OR N NOT IN OUR FIELD OF EXPERTISE. What would constitute a standard water supply? It will be whatever is necessary to service a 121 unit residential building fully sprinklered.**
 - o Fully Supervised System – **Y OR N YES**

Curtis Ferguson, B.A.Sc., E.I.T. | Land Development

NOVATECH Engineers, Planners & Landscape Architects

240 Michael Cowpland Drive, Suite 200, Ottawa, ON, K2M 1P6 | Tel: 613.254.9643 EXT: 331 | Fax: 613.254.5867

The information contained in this email message is confidential and is for exclusive use of the addressee.

AVIS DE CONFIDENTIALITÉ : Le présent courriel en provenance d'EVOQ Architecture peut contenir des renseignements confidentiels ou privilégiés. Si vous avez reçu ce message par erreur, nous vous prions d'en aviser immédiatement l'expéditeur, de supprimer ce courriel et d'en détruire toute copie.

CONFIDENTIALITY NOTICE: The present email communication from EVOQ Architecture may contain information that is confidential or privileged. If you have received this email in error, please notify the sender and destroy this email immediately as well as any copies you may have of it.

AVIS DE CONFIDENTIALITÉ : Le présent courriel en provenance d'EVOQ Architecture peut contenir des renseignements confidentiels ou privilégiés. Si vous avez reçu ce message par erreur, nous vous prions d'en aviser immédiatement l'expéditeur, de supprimer ce courriel et d'en détruire toute copie.

CONFIDENTIALITY NOTICE: The present email communication from EVOQ Architecture may contain information that is confidential or privileged. If you have received this email in error, please notify the sender and destroy this email immediately as well as any copies you may have of it.

From: Surprenant, Eric <Eric.Surprenant@ottawa.ca>
Sent: Tuesday, January 10, 2023 8:53 AM
To: Anthony Mestwarp <a.mestwarp@novatech-eng.com>
Cc: Dieme, Abi <Abibatou.Dieme@ottawa.ca>
Subject: Fw: 1500 Merivale Water Boundary Conditions

Hello Anthony,

The following are boundary conditions, HGL, for hydraulic analysis at 1500 Merivale Road (zone ME) assumed to be connected to the 406 mm on Baseline Road (Zone 2W2C), as well as a 203 mm internal loop connected to the 305 mm on Merivale Road (see attached PDF for location).

	Merivale Road (Zone ME)		Baseline Road (Zone 2W2C)		
	Connection 1	Connection 2	Connection 3	Connection 4	Connection 5
	HGL (m)	HGL (m)	HGL (m)	HGL (m)	HGL (m)
Min HGL	144.7	144.7	124.9	124.9	124.9
Max HGL	157.9	157.9	133.0	133.0	133.0
Max Day + FF (117 L/s)	152.8	152.8	N/A	N/A	N/A
Max Day + FF (133 L/s)	N/A	N/A	127.5	127.4	127.2

The maximum pressure is estimated to be more than 80 psi. A pressure check at completion of construction is recommended to determine if pressure control is required.

These are for current conditions and are based on computer model simulation.

Disclaimer: The boundary condition information is based on current operation of the city water distribution system. The computer model simulation is based on the best information available at the time. The operation of the water distribution system can change on a regular basis, resulting in a variation in boundary conditions. The physical properties of watermains deteriorate over time, as such must be assumed in the absence of actual field test data. The variation in physical watermain properties can therefore alter the results of the computer model simulation.

Thanks

Eric Surprenant, CET
 Sr, Project Manager, Infrastructure Projects, West
 Planning, Real Estate & Economic Development
 613 580-2424 ext.: 27794

Absence Alert:

From: Anthony Mestwarp <a.mestwarp@novatech-eng.com>

Sent: December 6, 2022 13:21

To: Surprenant, Eric <Eric.Surprenant@ottawa.ca>

Cc: Curtis Ferguson <c.ferguson@novatech-eng.com>; Dieme, Abi <Abibatou.Dieme@ottawa.ca>

Subject: RE: 1500 Merivale Water Boundary Conditions

**CAUTION: This email originated from an External Sender. Please do not click links or open attachments unless you recognize the source.
ATTENTION : Ce courriel provient d'un expéditeur externe. Ne cliquez sur aucun lien et n'ouvrez pas de pièce jointe, excepté si vous connaissez l'expéditeur.**

Hi Eric,

Presently phases 4-6 each are shown with individual connections to Baseline.

Phases 1-3 and 7-11 will be serviced by a proposed watermain on-site which will connect to Merivale in two locations as noted on the attached watermain connection figure.

Presently we are planning for a detailed submission of phase 1 and a serviceability level for the remaining phases.

Please let me know if you have any questions.

Regards,

Anthony Mestwarp, P.Eng., Project Engineer | Land Development Engineering

NOVATECH Engineers, Planners & Landscape Architects

240 Michael Cowpland Drive, Suite 200, Ottawa, ON, K2M 1P6 | Tel: 613.254.9643 Ext. 216 | Fax: 613.254.5867

The information contained in this email message is confidential and is for exclusive use of the addressee.

From: Surprenant, Eric <Eric.Surprenant@ottawa.ca>

Sent: Tuesday, December 6, 2022 12:22 PM

To: Anthony Mestwarp <a.mestwarp@novatech-eng.com>

Cc: Curtis Ferguson <c.ferguson@novatech-eng.com>; Dieme, Abi <Abibatou.Dieme@ottawa.ca>

Subject: Fw: 1500 Merivale Water Boundary Conditions

Hello Anthony,

I just wanted to advise you that Abi will be taking over the review of this application. I have forwarded the Boundary Conditions request and wanted to confirm the approach we would like to take.

Proposed Development Conditions - Baseline Connections

	Building B Phase 4	Building C Phase 5	Building D Phase 6	Totals
Studio	8	10	20	38
1 Bed Apartment	181	170	120	471
2 Bed Apartment	28	65	33	126
3 Bed Apartment	10	12	23	45
Townhome	0	0	0	0
Number of units	227	257	196	680
Population	354.4	425.7	336.6	1116.7
Total Res Daily Volume	99232.00	119196.00	94248.00	312676.00
Commercial area (m2)	118.11	101.95	56.99	277.05
Total Com Daily Volume	952.5	822.18	459.60	2234.27
Total Daily Volume (Liters)	100184.5	120018.2	94707.60	314910.3
Avg Day Demand (L/s)	1.160	1.389	1.096	3.64
Max Day Demand (L/s)	2.888	3.463	2.735	9.09
Peak Hour Demand (L/s)	6.347	7.613	6.014	19.974

Proposed Development Conditions - Merivale Connection

	Building A Phase 1	Building B Phase 2	Building B Phase 3	Building D Phase 7	Building D Phase 8	Building D Phase 9	Building E Phase 10	Building E Phase 11	Park	Totals
Studio	1	9	0	0	16	0	0	1		27
1 Bed Apartment	71	218	21	119	153	170	190	43		985
2 Bed Apartment	25	27	46	35	23	42	89	14		301
3 Bed Apartment	14	14	0	0	0	0	8	22		58
Townhome	7	8	0	8	6	0	0	5		34
Park Area (ha)	n/a	n/a	n/a	n/a	n/a	n/a	n/a	n/a	0.56	0.56
Number of units	118	276	67	162	198	212	287	85	n/a	1405
Population	215.6	439.5	126	261.7	301.1	326.2	477.7	172.7	n/a	2320.5
Total Res Daily Volume	60368.00	123060.00	35280.00	73276.00	84308.00	91336.00	133756.00	48356.00	156.8	649896.80
Commercial area (m2)	168.52	135.26	n/a	n/a	n/a	156.36	412.3	170	n/a	1042.44

The Boundary conditions would be provided as 3 sets of Boundary Conditions given their connection points, instead of for every single phase.

So 1st would include Phases 1, 2, 3

2nd would include Phases 4, 5, 6

and 3rd would include Phases 7 through 11.

Please confirm what the plans are for looping internally and at what Phases.

Please also let me know if you have any questions or concerns with this approach.

Thanks

Eric Surprenant, CET

Sr, Project Manager, Infrastructure Projects, West

Planning, Real Estate & Economic Development

613 580-2424 ext.: 27794

Please take note that due to current COVID situation, I am working remotely and Phone communications and messaging may not be reliable at this time. Preferred method of communications will be e-mails during this period. If your preference is telephone communication, please indicate this via e-mail and provide a contact telephone number.

Absence Alert:

From: Anthony Mestwarp <a.mestwarp@novatech-eng.com>

Sent: November 30, 2022 3:34 PM

To: Kuruvilla, Santhosh <Santhosh.Kuruvilla@ottawa.ca>

Cc: Curtis Ferguson <c.ferguson@novatech-eng.com>; Greg MacDonald <g.Macdonald@novatech-eng.com>

Subject: RE: 1500 Merivale Water Boundary Conditions

**CAUTION: This email originated from an External Sender. Please do not click links or open attachments unless you recognize the source.
ATTENTION : Ce courriel provient d'un expéditeur externe. Ne cliquez sur aucun lien et n'ouvrez pas de pièce jointe, excepté si vous connaissez l'expéditeur.**

Hi Santhosh,

I hope you are doing well.

Please find attached the updated water calculations for the 1500 Merivale site per the revised site plan.

They are also summarized below:

Merivale:

Phase 1: Avg day = 0.714, Max day = 1.77, Peak hour = 3.885, FUS= 67
Phase 2: Avg day = 1.437, Max day = 3.580, Peak hour = 7.868, FUS= 83
Phase 3: Avg day = 0.408, Max day = 1.021, Peak hour = 2.246, FUS= 33
Phase 7: Avg day = 0.848, Max day = 2.120, Peak hour = 4.665, FUS= 83
Phase 8: Avg day = 0.976, Max day = 2.439, Peak hour = 5.367, FUS= 100
Phase 9: Avg day = 1.072, Max day = 2.665, Peak hour = 5.854, FUS= 100
Phase 10: Avg day = 1.587, Max day = 3.928, Peak hour = 8.618, FUS= 117
Phase 11: Avg day = 0.576, Max day = 1.423, Peak hour = 3.121, FUS= 67
Park : Avg day = 0.002, Max day = 0.005, Peak hour = 0.010, FUS= N/A

Total : Avg day = 7.62, Max day = 18.95, Peak hour = 41.63 FUS (highest 117L/s)

Baseline Avenue:

Phase 4: Avg day = 1.160, Max day = 2.888, Peak hour = 6.347, FUS= 83
Phase 5: Avg day = 1.389, Max day = 3.463, Peak hour = 7.613, FUS= 133
Phase 6: Avg day = 1.096, Max day = 2.735, Peak hour = 6.014, FUS= 100

Total : Avg day = 3.64, Max day = 9.09, Peak hour = 19.974 FUS (highest 133L/s)

As you are aware the site will be developed over a number of years.

Calculations and figures are attached for your reference.

Please let us know if you require anything further.

Thanks,

Anthony Mestwarp, P.Eng., Project Engineer | Land Development Engineering

NOVATECH Engineers, Planners & Landscape Architects

240 Michael Cowpland Drive, Suite 200, Ottawa, ON, K2M 1P6 | Tel: 613.254.9643 Ext. 216 | Fax: 613.254.5867

The information contained in this email message is confidential and is for exclusive use of the addressee.

Boundary Conditions for 1500 Merivale Road

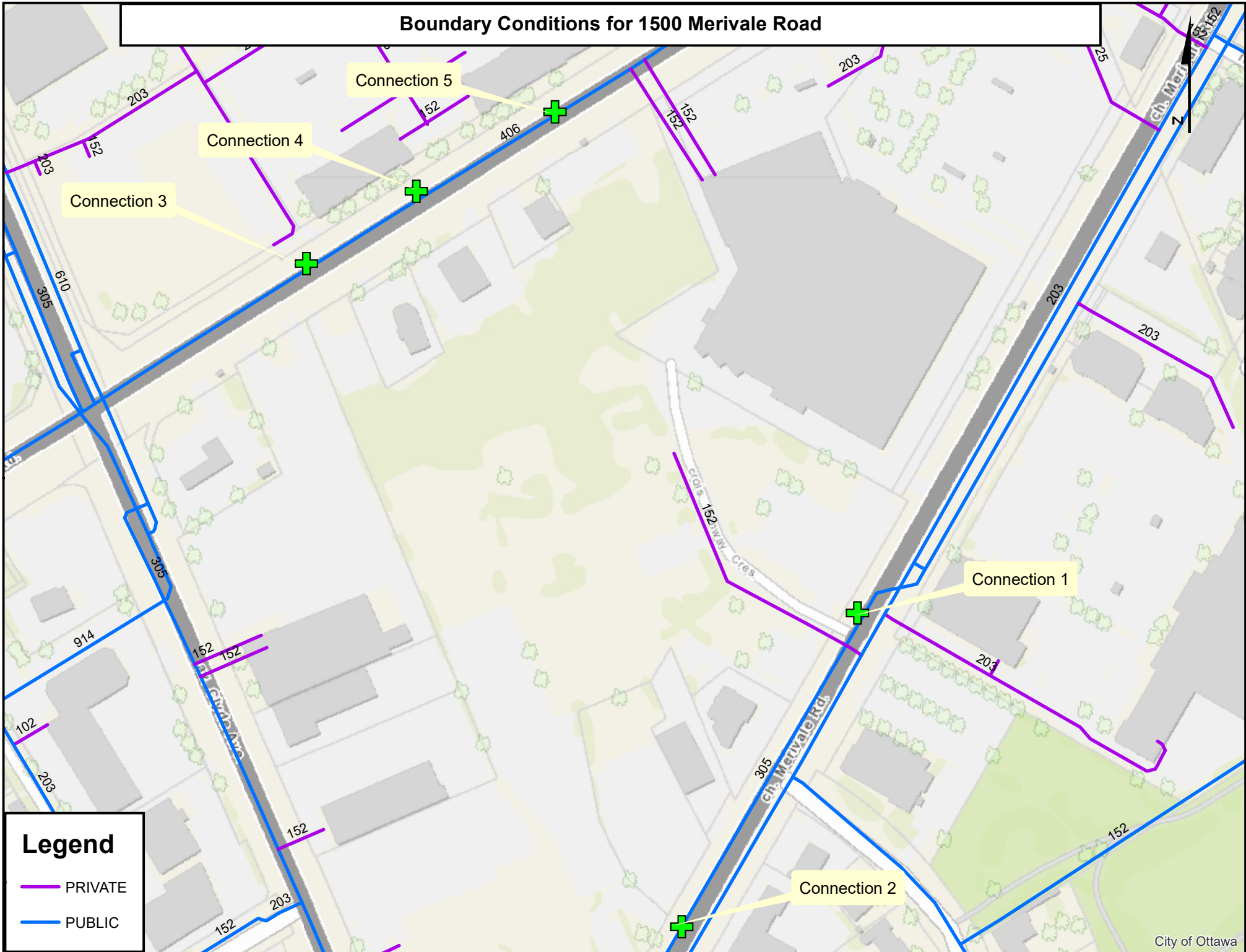

Legend

- PRIVATE
- PUBLIC

M:\2021\1121009\CAD\Design\Figures\EPA\1121009-EPA.dwg, EPA, May 29, 2023 - 12:51pm, amestwarp

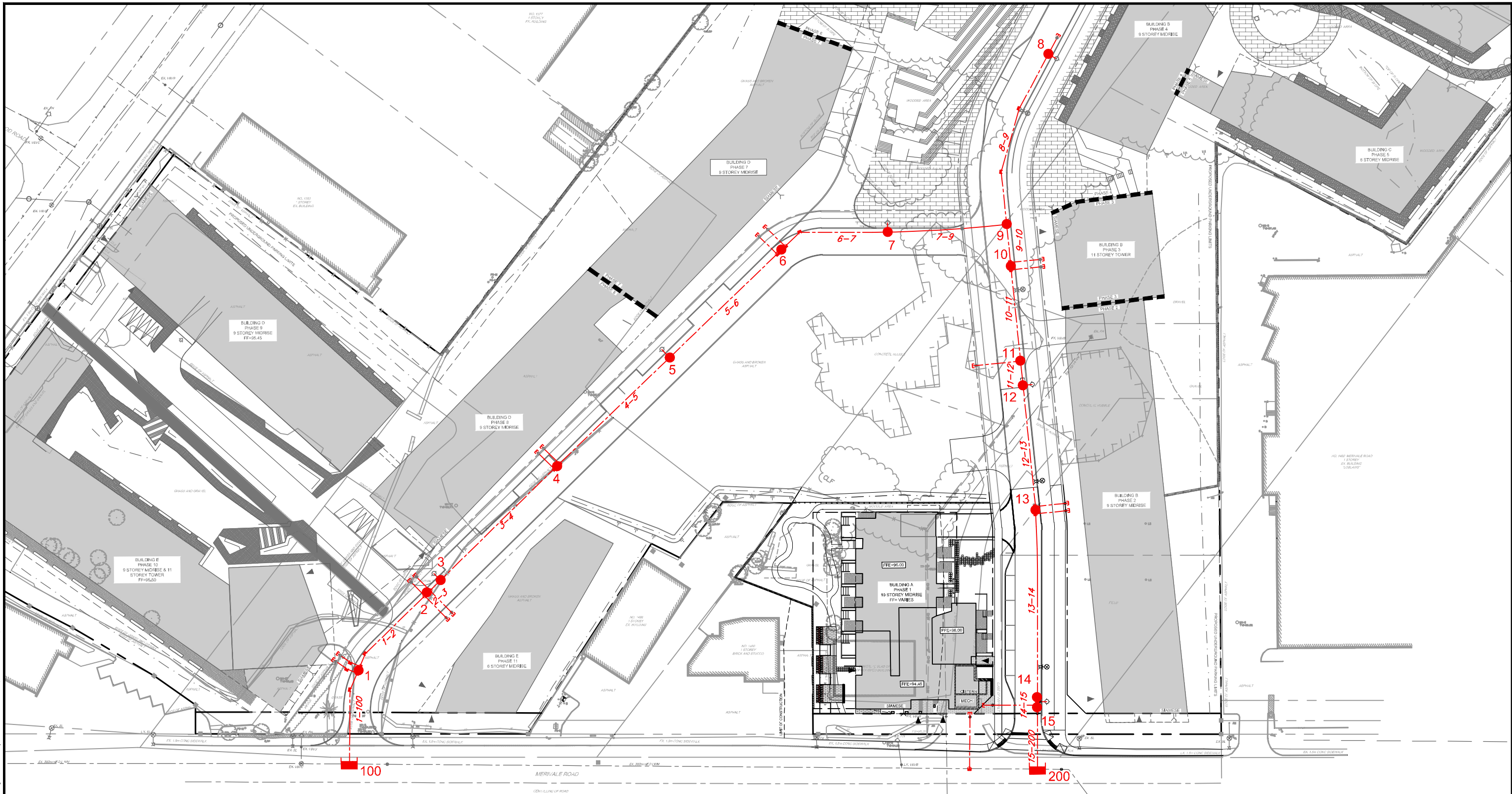

LEGEND

- 200mmØ WATERMAIN PIPE
- WATERMAIN NODE
- RESERVOIR

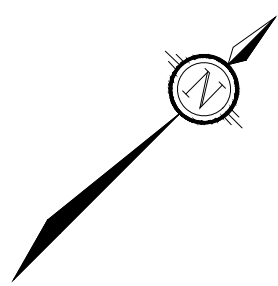

NOVATECH
 Engineers, Planners & Landscape Architects
 Suite 200, 240 Michael Cowpland Drive
 Ottawa, Ontario, Canada K2M 1P6

Telephone (613) 254-9643
 Facsimile (613) 254-5867
 Website www.novatech-eng.com

CITY OF OTTAWA
 1500 MERIVALE ROAD

WATERMAIN LAYOUT PLAN

SCALE 1 : 1000

DATE MAY 2023 JOB 121009 FIGURE EPA

Pipe Data				
Pipe	Length (m)	Diameter Nominal (mm)	Diameter Actual (mm)	Roughness Coefficient
100-1	25.55	200	204	110
1-2	21.81	200	204	110
2-3	5	200	204	110
3-4	43.66	200	204	110
4-5	41.98	200	204	110
5-6	41.61	200	204	110
6-7	54.07	200	204	110
7-9	32.02	200	204	110
8-9	48.32	200	204	110
9-10	11.22	200	204	110
10-11	25.59	200	204	110
12	6.57	200	204	110
12-13	33.61	200	204	110
13-14	51.34	200	204	110
14-15	1	200	204	110
15-200	17.17	200	204	110

High Pressure Check						
Node	Elevation (m)	Demand (LPS)	Head (m)	Pressure		Age* (hrs)
				(m)	(PSI)	
1	94.5	1.59	157.9	63.4	90.15	0.05
2	94.64	1.65	157.89	63.25	89.94	0.13
3(HYD)	94.74	0	157.89	63.15	89.80	0.17
4	95.79	0.98	157.89	62.1	88.30	0.53
5(HYD)	95.75	0	157.89	62.14	88.36	3.72
6	96.38	0.85	157.89	61.51	87.47	2.66
7(HYD)	96.88	0	157.89	61.01	86.75	1.3
8(HYD)	99.64	0	157.89	58.25	82.83	72
9	97.27	0	157.89	60.62	86.20	0.9
10	96.73	0.41	157.89	61.16	86.97	0.76
11	95.79	0	157.89	62.1	88.30	0.55
12	95.59	0	157.89	62.3	88.59	0.5
13	94.56	1.44	157.89	63.33	90.05	0.23
14	94.09	0.71	157.9	63.81	90.74	0.05
15	94.10	0	157.9	63.8	90.72	0.05
100	N/A	-4.33	157.9		0.00	0
200	N/A	-3.29	157.9		0.00	0

Maximum Age

Maximum Pressure

* Age is based on a boundary age of 0 hrs

1m of head = 1.42197 PSI

Maximum Daily Demand and Fire Flow					
Node 3 (HYD) - 117L/s Fire Demand					
Node	Elevation (m)	Demand (LPS)	Head (m)	Pressure	
				(m)	(PSI)
1	94.5	3.93	151.31	56.81	80.78
2	94.64	4.09	149.97	55.33	78.68
3(HYD)	94.74	117	149.51	54.77	77.88
4	95.79	2.44	149.80	54.01	76.80
5(HYD)	95.75	0	150.13	54.38	77.33
6	96.38	2.12	150.46	54.08	76.90
7(HYD)	96.88	0	150.94	54.06	76.87
8(HYD)	99.64	0	151.23	51.59	73.36
9	97.27	0	151.23	53.96	76.73
10	96.73	1.02	151.34	54.61	77.65
11	95.79	0	151.60	55.81	79.36
12	95.59	0	151.67	56.08	79.74
13	94.56	3.58	151.99	57.43	81.66
14	94.09	1.77	152.54	58.45	83.11
15	94.10	0	152.60	58.50	83.19
100	N/A	-94.52	152.80	0.00	0.00
200	N/A	-41.43	152.80	0.00	0.00

Minimum Pressure

Maximum Daily Demand and Fire Flow					
Node 5 (HYD) - 100L/s Fire Demand					
Node	Elevation (m)	Demand (LPS)	Head (m)	Pressure	
				(m)	(PSI)
1	94.5	3.93	151.96	57.46	81.71
2	94.64	4.09	151.23	56.59	80.47
3(HYD)	94.74	0	150.99	56.25	79.99
4	95.79	2.44	149.92	54.13	76.97
5(HYD)	95.75	100	148.94	53.19	75.63
6	96.38	2.12	149.44	53.06	75.45
7(HYD)	96.88	0	150.14	53.26	75.73
8(HYD)	99.64	0	150.56	50.92	72.41
9	97.27	0	150.56	53.29	75.78
10	96.73	1.02	150.73	54.00	76.79
11	95.79	0	151.10	55.31	78.65
12	95.59	0	151.21	55.62	79.09
13	94.56	3.58	151.67	57.11	81.21
14	94.09	1.77	152.44	58.35	82.97
15	94.10	0	152.52	58.42	83.07
100	N/A	-69.61	152.80	0.00	0.00
200	N/A	-49.34	152.80	0.00	0.00

Minimum Pressure

Maximum Daily Demand and Fire Flow					
Node 7 (HYD) - 83L/s Fire Demand					
Node	Elevation (m)	Demand (LPS)	Head (m)	Pressure	
				(m)	(PSI)
1	94.5	3.93	152.35	57.85	82.26
2	94.64	4.09	151.97	57.33	81.52
3(HYD)	94.74	0	151.86	57.12	81.22
4	95.79	2.44	151.33	55.54	78.98
5(HYD)	95.75	0	150.87	55.12	78.38
6	96.38	2.12	150.40	54.02	76.81
7(HYD)	96.88	83	149.86	52.98	75.34
8(HYD)	99.64	0	150.32	50.68	72.07
9	97.27	0	150.32	53.05	75.44
10	96.73	1.02	150.51	53.78	76.47
11	95.79	0	150.92	55.13	78.39
12	95.59	0	151.04	55.45	78.85
13	94.56	3.58	151.55	56.99	81.04
14	94.09	1.77	152.40	58.31	82.92
15	94.10	0	152.49	58.39	83.03
100	N/A	-50.04	152.80	0.00	0.00
200	N/A	-51.91	152.80	0.00	0.00

Minimum Pressure

Maximum Daily Demand and Fire Flow					
Node 8 (HYD) - 83L/s Fire Demand					
Node	Elevation (m)	Demand (LPS)	Head (m)	Pressure	
				(m)	(PSI)
1	94.5	3.93	152.4	57.9	82.33
2	94.64	4.09	152.07	57.43	81.66
3(HYD)	94.74	0	151.98	57.24	81.39
4	95.79	2.44	151.52	55.73	79.25
5(HYD)	95.75	0	151.13	55.38	78.75
6	96.38	2.12	150.73	54.35	77.28
7(HYD)	96.88	0	150.27	53.39	75.92
8(HYD)	99.64	83	147.80	48.16	68.48
9	97.27	0	150.00	52.73	74.98
10	96.73	1.02	150.21	53.48	76.05
11	95.79	0	150.68	54.89	78.05
12	95.59	0	150.82	55.23	78.54
13	94.56	3.58	151.40	56.84	80.82
14	94.09	1.77	152.36	58.27	82.86
15	94.10	0	152.46	58.36	82.99
100	N/A	-46.76	152.80	0.00	0.00
200	N/A	-55.19	152.80	0.00	0.00

Minimum Pressure

Maximum Daily Demand and Fire Flow					
Node 12 (HYD) - 83L/s Fire Demand					
Node	Elevation (m)	Demand (LPS)	Head (m)	Pressure	
				(m)	(PSI)
1	94.5	3.93	152.48	57.98	82.45
2	94.64	4.09	152.23	57.59	81.89
3(HYD)	94.74	0	152.16	57.42	81.65
4	95.79	2.44	151.82	56.03	79.67
5(HYD)	95.75	0	151.53	55.78	79.32
6	96.38	2.12	151.23	54.85	78.00
7(HYD)	96.88	0	150.90	54.02	76.81
8(HYD)	99.64	0	150.70	51.06	72.61
9	97.27	0	150.70	53.43	75.98
10	96.73	1.02	150.62	53.89	76.63
11	95.79	0	150.47	54.68	77.75
12	95.59	83	150.42	54.83	77.97
13	94.56	3.58	151.12	56.56	80.43
14	94.09	1.77	152.27	58.18	82.73
15	94.10	0	152.39	58.29	82.89
100	N/A	-41.3	152.80	0.00	0.00
200	N/A	-60.65	152.80	0.00	0.00

Minimum Pressure

Maximum Daily Demand and Fire Flow					
Node 15 (HYD) - 67L/s Fire Demand					
Node	Elevation (m)	Demand (LPS)	Head (m)	Pressure	
				(m)	(PSI)
1	94.5	3.93	152.7	58.2	82.76
2	94.64	4.09	152.64	58.00	82.47
3(HYD)	94.74	0	152.63	57.89	82.32
4	95.79	2.44	152.56	56.77	80.73
5(HYD)	95.75	0	152.52	56.77	80.73
6	96.38	2.12	152.47	56.09	79.76
7(HYD)	96.88	0	152.43	55.55	78.99
8(HYD)	99.64	0	152.41	52.77	75.04
9	97.27	0	152.41	55.14	78.41
10	96.73	1.02	152.40	55.67	79.16
11	95.79	0	152.38	56.59	80.47
12	95.59	0	152.38	56.79	80.75
13	94.56	3.58	152.36	57.80	82.19
14	94.09	1.77	152.35	58.26	82.84
15	94.10	67	152.35	58.25	82.83
100	N/A	-21.8	152.80	0.00	0.00
200	N/A	-64.15	152.80	0.00	0.00

Minimum Pressure

PEAK HOUR					
Node	Elevation (m)	Demand (LPS)	Head (m)	Pressure	
				(m)	(PSI)
1	94.5	8.62	144.59	50.09	71.23
2	94.64	8.98	144.54	49.90	70.96
3(HYD)	94.74	0.00	144.54	49.80	70.81
4	95.79	5.37	144.53	48.74	69.31
5(HYD)	95.75	0.00	144.53	48.78	69.36
6	96.38	4.66	144.53	48.15	68.47
7(HYD)	96.88	0.00	144.53	47.65	67.76
8(HYD)	99.64	0.00	144.54	44.90	63.85
9	97.27	0.00	144.54	47.27	67.22
10	96.73	2.25	144.54	47.81	67.98
11	95.79	0.01	144.55	48.76	69.34
12	95.59	0.00	144.55	48.96	69.62
13	94.56	7.87	144.57	50.01	71.11
14	94.09	3.88	144.65	50.56	71.89
15	94.10	0.00	144.66	50.56	71.89
100	N/A	-23.63	144.70	0.00	0.00
200	N/A	-18.01	144.70	0.00	0.00

Minimum Pressure

```

*****
*                               E P A N E T                               *
*                               Hydraulic and Water Quality                 *
*                               Analysis for Pipe Networks                 *
*                               Version 2.2                               *
*****

```

Link - Node Table:

Link ID	Start Node	End Node	Length m	Diameter mm
100-1	100	1	25.55	204
1-2	1	2	21.81	204
2-3	2	3(HYD)	5	204
3-4	3(HYD)	4	43.66	204
4-5	4	5(HYD)	41.98	204
5-6	5(HYD)	6	41.61	204
6-7	6	7(HYD)	54.07	204
7-9	7(HYD)	9	32.02	204
8-9	8(HYD)	9	48.32	204
9-10	9	10	11.22	204
10-11	10	11	25.59	204
12	11	12(HYD)	6.57	204
12-13	12(HYD)	13	33.61	204
13-14	13	14	51.34	204
14-15	14	15(HYD)	1	204
15-200	15(HYD)	200	17.17	204

Node Results (Average Day):

Node ID	Demand LPS	Head m	Pressure m	Quality
1	1.59	157.90	63.40	0.05
2	1.65	157.89	63.25	0.13
3(HYD)	0.00	157.89	63.15	0.17
4	0.98	157.89	62.10	0.53
5(HYD)	0.00	157.89	62.14	3.72
6	0.85	157.89	61.51	2.66
7(HYD)	0.00	157.89	61.01	1.30
8(HYD)	0.00	157.89	58.25	72.00
9	0.00	157.89	60.62	0.90
10	0.41	157.89	61.16	0.76
11	0.00	157.89	62.10	0.55
12	0.00	157.89	62.30	0.50
13	1.44	157.89	63.33	0.23
14	0.71	157.90	63.81	0.05
15	0.00	157.90	63.80	0.05
100	-4.33	157.90	0.00	0.00 Reservoir
200	-3.29	157.90	0.00	0.00 Reservoir

```

*****
*                               E P A N E T                               *
*                               Hydraulic and Water Quality                 *
*                               Analysis for Pipe Networks                   *
*                               Version 2.2                                 *
*****

```

Link Results(Average Day):

Link ID	Flow LPS	Velocity m/s	Unit Headloss m/km	Status
100-1	4.33	0.13	0.18	Open
1-2	2.74	0.08	0.09	Open
2-3	1.10	0.03	0.02	Open
3-4	1.10	0.03	0.01	Open
4-5	0.12	0.00	0.00	Open
5-6	0.12	0.00	0.00	Open
6-7	-0.73	0.02	0.01	Open
7-9	-0.73	0.02	0.01	Open
8-9	0.00	0.00	0.00	Open
9-10	-0.73	0.02	0.01	Open
10-11	-1.14	0.03	0.02	Open
12	-1.14	0.03	0.02	Open
12-13	-1.14	0.03	0.01	Open
13-14	-2.58	0.08	0.07	Open
14-15	-3.29	0.10	0.39	Open
15-200	-3.29	0.10	0.11	Open

```

*****
*                               E P A N E T                               *
*                               Hydraulic and Water Quality                 *
*                               Analysis for Pipe Networks                   *
*                               Version 2.2                                 *
*****

```

Node Results (Max Day + Fire Flow- Node 3-Phase 10):

Node ID	Demand LPS	Head m	Pressure m	Quality
1	3.93	151.31	56.81	0.00
2	4.09	149.97	55.33	0.00
3(HYD)	117.00	149.51	54.77	0.00
4	2.44	149.80	54.01	0.00
5(HYD)	0.00	150.13	54.38	0.00
6	2.12	150.46	54.08	0.00
7(HYD)	0.00	150.94	54.06	0.00
8(HYD)	0.00	151.23	51.59	0.00
9	0.00	151.23	53.96	0.00
10	1.02	151.34	54.61	0.00
11	0.00	151.60	55.81	0.00
12(HYD)	0.00	151.67	56.08	0.00
13	3.58	151.99	57.43	0.00
14	1.77	152.54	58.45	0.00
15(HYD)	0.00	152.60	58.50	0.00
100	-94.52	152.80	0.00	0.00 Reservoir
200	-41.43	152.80	0.00	0.00 Reservoir

Link Results (Max Day + Fire Flow- Node 3-Phase 10):

Link ID	Flow LPS	Velocity m/s	Headloss m/km	Status
100-1	94.52	2.89	58.13	Open
1-2	90.59	2.77	61.72	Open
2-3	86.51	2.65	91.62	Open
3-4	-30.49	0.93	6.64	Open
4-5	-32.93	1.01	7.81	Open
5-6	-32.93	1.01	8.02	Open
6-7	-35.05	1.07	8.88	Open
7-9	-35.05	1.07	8.94	Open
8-9	0.00	0.00	0.00	Open
9-10	-35.05	1.07	10.26	Open
10-11	-36.07	1.10	10.03	Open
12	-36.08	1.10	11.32	Open
12-13	-36.08	1.10	9.39	Open
13-14	-39.66	1.21	10.74	Open
14-15	-41.43	1.27	57.04	Open
15-200	-41.43	1.27	11.73	Open

```

*****
*                               E P A N E T                               *
*                               Hydraulic and Water Quality                *
*                               Analysis for Pipe Networks                 *
*                               Version 2.2                               *
*****

```

Node Results (Max Day + Fire Flow- Node 5-Phase 8):

Node ID	Demand LPS	Head m	Pressure m	Quality
1	3.93	151.96	57.46	0.00
2	4.09	151.23	56.59	0.00
3(HYD)	0.00	150.99	56.25	0.00
4	2.44	149.92	54.13	0.00
5(HYD)	100.00	148.94	53.19	0.00
6	2.12	149.44	53.06	0.00
7(HYD)	0.00	150.14	53.26	0.00
8(HYD)	0.00	150.56	50.92	0.00
9	0.00	150.56	53.29	0.00
10	1.02	150.73	54.00	0.00
11	0.00	151.10	55.31	0.00
12(HYD)	0.00	151.21	55.62	0.00
13	3.58	151.67	57.11	0.00
14	1.77	152.44	58.35	0.00
15(HYD)	0.00	152.52	58.42	0.00
100	-69.61	152.80	0.00	0.00 Reservoir
200	-49.34	152.80	0.00	0.00 Reservoir

Link Results (Max Day + Fire Flow- Node 5-Phase 8):

Link ID	Flow LPS	Velocity m/s	Headloss m/km	Status
100-1	69.61	2.13	32.82	Open
1-2	65.69	2.01	33.67	Open
2-3	61.60	1.88	47.60	Open
3-4	61.60	1.88	24.52	Open
4-5	59.16	1.81	23.22	Open
5-6	-40.84	1.25	11.98	Open
6-7	-42.96	1.31	12.98	Open
7-9	-42.96	1.31	13.06	Open
8-9	0.00	0.00	0.00	Open
9-10	-42.96	1.31	15.04	Open
10-11	-43.98	1.35	14.54	Open
12	-43.99	1.35	16.45	Open
12-13	-43.99	1.35	13.59	Open
13-14	-47.57	1.46	15.06	Open
14-15	-49.34	1.51	80.48	Open
15-200	-49.34	1.51	16.23	Open

```

*****
*                               E P A N E T                               *
*                               Hydraulic and Water Quality                *
*                               Analysis for Pipe Networks                  *
*                               Version 2.2                                *
*****

```

Node Results (Max Day + Fire Flow- Node 7-Phase 7):

Node ID	Demand LPS	Head m	Pressure m	Quality	
1	3.93	152.35	57.85	0.00	
2	4.09	151.97	57.33	0.00	
3(HYD)	0.00	151.86	57.12	0.00	
4	2.44	151.33	55.54	0.00	
5(HYD)	0.00	150.87	55.12	0.00	
6	2.12	150.40	54.02	0.00	
7(HYD)	83.00	149.86	52.98	0.00	
8(HYD)	0.00	150.32	50.68	0.00	
9	0.00	150.32	53.05	0.00	
10	1.02	150.51	53.78	0.00	
11	0.00	150.92	55.13	0.00	
12(HYD)	0.00	151.04	55.45	0.00	
13	3.58	151.55	56.99	0.00	
14	1.77	152.40	58.31	0.00	
15(HYD)	0.00	152.49	58.39	0.00	
100	-50.04	152.80	0.00	0.00	Reservoir
200	-51.91	152.80	0.00	0.00	Reservoir

Link Resultss (Max Day + Fire Flow- Node 7-Phase 7):

Link ID	Flow LPS	Velocity m/s	Headloss m/km	Status
100-1	50.04	1.53	17.72	Open
1-2	46.11	1.41	17.29	Open
2-3	42.02	1.29	22.78	Open
3-4	42.02	1.29	12.04	Open
4-5	39.58	1.21	10.99	Open
5-6	39.58	1.21	11.30	Open
6-7	37.46	1.15	10.05	Open
7-9	-45.54	1.39	14.55	Open
8-9	0.00	0.00	0.00	Open
9-10	-45.54	1.39	16.79	Open
10-11	-46.56	1.42	16.17	Open
12	-46.56	1.42	18.32	Open
12-13	-46.56	1.42	15.11	Open
13-14	-50.14	1.53	16.61	Open
14-15	-51.91	1.59	88.98	Open
15-200	-51.91	1.59	17.84	Open

```

*****
*                               E P A N E T                               *
*                               Hydraulic and Water Quality                 *
*                               Analysis for Pipe Networks                 *
*                               Version 2.2                               *
*****

```

Node Results (Max Day + Fire Flow- Node 8-Phase 4):

Node ID	Demand LPS	Head m	Pressure m	Quality
1	3.93	152.40	57.90	0.00
2	4.09	152.07	57.43	0.00
3(HYD)	0.00	151.98	57.24	0.00
4	2.44	151.52	55.73	0.00
5(HYD)	0.00	151.13	55.38	0.00
6	2.12	150.73	54.35	0.00
7(HYD)	0.00	150.27	53.39	0.00
8(HYD)	83.00	147.80	48.16	0.00
9	0.00	150.00	52.73	0.00
10	1.02	150.21	53.48	0.00
11	0.00	150.68	54.89	0.00
12(HYD)	0.00	150.82	55.23	0.00
13	3.58	151.40	56.84	0.00
14	1.77	152.36	58.27	0.00
15(HYD)	0.00	152.46	58.36	0.00
100	-46.76	152.80	0.00	0.00 Reservoir
200	-55.19	152.80	0.00	0.00 Reservoir

Link Results (Max Day + Fire Flow- Node 8-Phase 4):

Link ID	Flow LPS	Velocity m/s	Headloss m/km	Status
100-1	46.76	1.43	15.61	Open
1-2	42.83	1.31	15.05	Open
2-3	38.74	1.19	19.49	Open
3-4	38.74	1.19	10.36	Open
4-5	36.30	1.11	9.36	Open
5-6	36.30	1.11	9.62	Open
6-7	34.18	1.05	8.48	Open
7-9	34.18	1.05	8.53	Open
8-9	-83.00	2.54	45.54	Open
9-10	-48.82	1.49	19.13	Open
10-11	-49.84	1.52	18.37	Open
12	-49.84	1.52	20.83	Open
12-13	-49.84	1.52	17.15	Open
13-14	-53.42	1.63	18.69	Open
14-15	-55.19	1.69	100.40	Open
15-200	-55.19	1.69	19.99	Open

```

*****
*                               E P A N E T                               *
*                               Hydraulic and Water Quality                 *
*                               Analysis for Pipe Networks                   *
*                               Version 2.2                                 *
*****

```

Node Results (Max Day + Fire Flow- Node 12-Phase 2):

Node ID	Demand LPS	Head m	Pressure m	Quality
1	3.93	152.48	57.98	0.00
2	4.09	152.23	57.59	0.00
3(HYD)	0.00	152.16	57.42	0.00
4	2.44	151.82	56.03	0.00
5(HYD)	0.00	151.53	55.78	0.00
6	2.12	151.23	54.85	0.00
7(HYD)	0.00	150.90	54.02	0.00
8(HYD)	0.00	150.70	51.06	0.00
9	0.00	150.70	53.43	0.00
10	1.02	150.62	53.89	0.00
11	0.00	150.47	54.68	0.00
12(HYD)	83.00	150.42	54.83	0.00
13	3.58	151.12	56.56	0.00
14	1.77	152.27	58.18	0.00
15(HYD)	0.00	152.39	58.29	0.00
100	-41.30	152.80	0.00	0.00 Reservoir
200	-60.65	152.80	0.00	0.00 Reservoir

Link Results (Max Day + Fire Flow- Node 12-Phase 2):

Link ID	Flow LPS	Velocity m/s	Headloss m/km	Status
100-1	41.30	1.26	12.38	Open
1-2	37.37	1.14	11.64	Open
2-3	33.28	1.02	14.55	Open
3-4	33.28	1.02	7.81	Open
4-5	30.84	0.94	6.91	Open
5-6	30.84	0.94	7.10	Open
6-7	28.72	0.88	6.13	Open
7-9	28.72	0.88	6.17	Open
8-9	0.00	0.00	0.00	Open
9-10	28.72	0.88	7.05	Open
10-11	27.70	0.85	6.12	Open
12	27.70	0.85	6.88	Open
12-13	-55.30	1.69	20.82	Open
13-14	-58.88	1.80	22.39	Open
14-15	-60.65	1.86	120.92	Open
15-200	-60.65	1.86	23.82	Open

```

*****
*                               E P A N E T                               *
*                               Hydraulic and Water Quality                 *
*                               Analysis for Pipe Networks                 *
*                               Version 2.2                               *
*****

```

Node Results (Max Day + Fire Flow- Node 15-Phase 1):

Node ID	Demand LPS	Head m	Pressure m	Quality	
1	3.93	152.70	58.20	0.00	
2	4.09	152.64	58.00	0.00	
3(HYD)	0.00	152.63	57.89	0.00	
4	2.44	152.56	56.77	0.00	
5(HYD)	0.00	152.52	56.77	0.00	
6	2.12	152.47	56.09	0.00	
7(HYD)	0.00	152.43	55.55	0.00	
8(HYD)	0.00	152.41	52.77	0.00	
9	0.00	152.41	55.14	0.00	
10	1.02	152.40	55.67	0.00	
11	0.00	152.38	56.59	0.00	
12(HYD)	0.00	152.38	56.79	0.00	
13	3.58	152.36	57.80	0.00	
14	1.77	152.35	58.26	0.00	
15(HYD)	67.00	152.35	58.25	0.00	
100	-21.80	152.80	0.00	0.00	Reservoir
200	-64.15	152.80	0.00	0.00	Reservoir

Link Results (Max Day + Fire Flow- Node 15-Phase 1):

Link ID	Flow LPS	Velocity m/s	Headloss m/km	Status
100-1	21.80	0.67	3.76	Open
1-2	17.87	0.55	2.91	Open
2-3	13.78	0.42	2.67	Open
3-4	13.78	0.42	1.52	Open
4-5	11.34	0.35	1.07	Open
5-6	11.34	0.35	1.10	Open
6-7	9.22	0.28	0.74	Open
7-9	9.22	0.28	0.74	Open
8-9	0.00	0.00	0.00	Open
9-10	9.22	0.28	0.83	Open
10-11	8.20	0.25	0.63	Open
12	8.20	0.25	0.69	Open
12-13	8.20	0.25	0.59	Open
13-14	4.62	0.14	0.20	Open
14-15	2.85	0.09	0.30	Open
15-200	-64.15	1.96	26.44	Open

```

*****
*                               E P A N E T                               *
*                               Hydraulic and Water Quality                 *
*                               Analysis for Pipe Networks                   *
*                               Version 2.2                                 *
*****

```

Node Results (PEAK HOUR):

Node ID	Demand LPS	Head m	Pressure m	Quality
1	8.62	144.59	50.09	0.00
2	8.98	144.54	49.90	0.00
3(HYD)	0.00	144.54	49.80	0.00
4	5.37	144.53	48.74	0.00
5(HYD)	0.00	144.53	48.78	0.00
6	4.66	144.53	48.15	0.00
7(HYD)	0.00	144.53	47.65	0.00
8(HYD)	0.00	144.54	44.90	0.00
9	0.00	144.54	47.27	0.00
10	2.25	144.54	47.81	0.00
11	0.01	144.55	48.76	0.00
12	0.00	144.55	48.96	0.00
13	7.87	144.57	50.01	0.00
14	3.88	144.65	50.56	0.00
15	0.00	144.66	50.56	0.00
100	-23.63	144.70	0.00	0.00 Reservoir
200	-18.01	144.70	0.00	0.00 Reservoir

Link Results (PEAK HOUR):

Link ID	Flow LPS	Velocity m/s	Headloss m/km	Status
100-1	23.63	0.72	4.37	Open
1-2	15.01	0.46	2.09	Open
2-3	6.04	0.18	0.55	Open
3-4	6.04	0.18	0.33	Open
4-5	0.67	0.02	0.01	Open
5-6	0.67	0.02	0.01	Open
6-7	-4.00	0.12	0.16	Open
7-9	-4.00	0.12	0.16	Open
8-9	0.00	0.00	0.00	Open
9-10	-4.00	0.12	0.17	Open
10-11	-6.24	0.19	0.38	Open
12	-6.25	0.19	0.42	Open
12-13	-6.25	0.19	0.36	Open
13-14	-14.12	0.43	1.58	Open
14-15	-18.01	0.55	11.05	Open
15-200	-18.01	0.55	2.49	Open

CALCULATED WATER DEMANDS

Connection 3 - (Baseline Road) [Phase 6]

Water Demands

Average Day (Maximum HGL)= 1.10 L/s
 Maximum Day = 2.74 L/s
 Peak Hour (Minimum HGL) = 6.01 L/s
 Fire Flow (FUS) = 117.00 L/s

City of Ottawa Boundary Conditions:

Boundary conditions based on connection to 400mm dia. Watermain in Baseline Road

Average Day (Maximum HGL)= 133 m
 Peak Hour (Minimum HGL) = 124.9 m
 Max Day + Fire = 127.5 m

Watermain Analysis

Water Entry Elevation = 98.44 m

High Pressure Test = Max. HGL - Water Entry Elevation x 1.42197 PSI/m < 80 PSI

High Pressure = 49.14 PSI

Low Pressure Test = Min. HGL - Water Entry Elevation x 1.42197 PSI/m > 40 PSI

Low Pressure = 37.63 PSI

Max Day + Fire Test = Max Day + Fire Flow - Water Entry Elevation x 1.42197 PSI/m > 20 PSI

Max Day + Fire = 41.32 PSI

CALCULATED WATER DEMANDS

Connection 4 - (Baseline Road) [Phase 4]

Water Demands

Average Day (Maximum HGL)=	1.16 L/s
Maximum Day =	2.89 L/s
Peak Hour (Minimum HGL) =	6.35 L/s
Fire Flow (FUS) =	100.00 L/s

City of Ottawa Boundary Conditions:

Boundary conditions based on connection to 400mm dia. Watermain in Baseline Road

Average Day (Maximum HGL)=	133 m
Peak Hour (Minimum HGL) =	124.9 m
Max Day + Fire =	127.4 m

Watermain Analysis

Water Entry Elevation 99.79 m

High Pressure Test = Max. HGL - Water Entry Elevation x 1.42197 PSI/m < 80 PSI

High Pressure = 47.22 PSI

Low Pressure Test = Min. HGL - Water Entry Elevation x 1.42197 PSI/m > 40 PSI

Low Pressure = 35.71 PSI

Max Day + Fire Test = Max Day + Fire Flow - Water Entry Elevation x 1.42197 PSI/m > 20 PSI

Max Day + Fire = 39.26 PSI

CALCULATED WATER DEMANDS

Connection 5 - (Baseline Road) [Phase 5]

Water Demands

Average Day (Maximum HGL)= 1.39 L/s
 Maximum Day = 3.46 L/s
 Peak Hour (Minimum HGL) = 7.61 L/s
 Fire Flow (FUS) = 133.00 L/s

City of Ottawa Boundary Conditions:

Boundary conditions based on connection to 400mm dia. Watermain in Baseline Road

Average Day (Maximum HGL)= 133 m
 Peak Hour (Minimum HGL) = 124.9 m
 Max Day + Fire = 127.2 m

Watermain Analysis

Water Entry Elevation = 98.80 m

High Pressure Test = Max. HGL - Water Entry Elevation x 1.42197 PSI/m < 80 PSI

High Pressure = 48.63 PSI

Low Pressure Test = Min. HGL - Water Entry Elevation x 1.42197 PSI/m > 40 PSI

Low Pressure = 37.11 PSI

Max Day + Fire Test = Max Day + Fire Flow - Water Entry Elevation x 1.42197 PSI/m > 20 PSI

Max Day + Fire = 40.38 PSI

Appendix F
Servicing Study Guidelines Checklist

Development Servicing Study Checklist

4.1 General Content	Addressed (Y/N/NA)	Section	Comments
Executive Summary (for larger reports only).	NA		
Date and revision number of the report.	Y	COVER	COVER 2
Location map and plan showing municipal address, boundary, and layout of proposed development.	Y	DWGS	ALL DRAWINGS
Plan showing the site and location of all existing services.	Y	DWG	GP
Development statistics, land use, density, adherence to zoning and official plan, and reference to applicable subwatershed and watershed plans that provide context to which individual developments must adhere.	Y	1.0	INTRODUCTION
Summary of Pre-consultation Meetings with City and other approval agencies.	Y	APP A	
Reference and confirm conformance to higher level studies and reports (Master Servicing Studies, Environmental Assessments, Community Design Plans), or in the case where it is not in conformance, the proponent must provide justification and develop a defensible design criteria.	Y	REPORT	ALL SECTIONS
Statement of objectives and servicing criteria.	Y	REPORT	SECTION 3,4,5
Identification of existing and proposed infrastructure available in the immediate area.	Y	DWG	GP
Identification of Environmentally Significant Areas, watercourses and Municipal Drains potentially impacted by the proposed development (Reference can be made to the Natural Heritage Studies, if available).	NA		
Concept level master grading plan to confirm existing and proposed grades in the development. This is required to confirm the feasibility of proposed stormwater management and drainage, soil removal and fill constraints, and potential impacts to neighboring properties. This is also required to confirm that the proposed grading will not impede existing major system flow paths.	Y	DWG	GR

Development Servicing Study Checklist

4.1 General Content	Addressed (Y/N/NA)	Section	Comments
Identification of potential impacts of proposed piped services on private services (such as wells and septic fields on adjacent lands) and mitigation required to address potential impacts.	NA		
Proposed phasing of the development, if applicable.	Y	REPORT	FIGURE 4
Reference to geotechnical studies and recommendations concerning servicing.	Y	2/DWG	SECTION 2 AND GR/GP
All preliminary and formal site plan submissions should have the following information:			
Metric scale	Y		ALL DRAWINGS
North arrow (including construction North)	Y		ALL DRAWINGS
Key plan	Y		ALL DRAWINGS
Name and contact information of applicant and property owner	Y		DRAWINGS/REPORT SECTION 1
Property limits including bearings and dimensions	Y		REPORT
Existing and proposed structures and parking areas	Y		ALL DRAWINGS
Easements, road widening and rights-of-way	Y		ALL DRAWINGS
Adjacent street names	Y		ALL DRAWINGS

Development Servicing Study Checklist

4.2 Water	Addressed (Y/N/NA)	Section	Comments
Confirm consistency with Master Servicing Study, if available.	NA		
Availability of public infrastructure to service proposed development.	Y	2 TO 4	DWG GP
Identification of system constraints.	NA		
Identify boundary conditions.	Y	5.0	REPORT
Confirmation of adequate domestic supply and pressure.	Y	5.0	REPORT
Confirmation of adequate fire flow protection and confirmation that fire flow is calculated as per the Fire Underwriter's Survey. Output should show available fire flow at locations throughout the development.	Y	5.0	APPENDIX D
Provide a check of high pressures. If pressure is found to be high, an assessment is required to confirm the application of pressure reducing valves.	Y	5.1	REPORT
Definition of phasing constraints. Hydraulic modeling is required to confirm servicing for all defined phases of the project including the ultimate design.	Y	4.0	REPORT
Address reliability requirements such as appropriate location of shut-off valves.	Y	DWGS	GP
Check on the necessity of a pressure zone boundary modification.	Y	5.0	REPORT/APPENDIX D
Reference to water supply analysis to show that major infrastructure is capable of delivering sufficient water for the proposed land use. This includes data that shows that the expected demands under average day, peak hour and fire flow conditions provide water within the required pressure range.	Y	5.0	REPORT/APPENDIX D
Description of the proposed water distribution network, including locations of proposed connections to the existing system, provisions for necessary looping, and appurtenances (valves, pressure reducing valves, valve chambers, and fire hydrants) including special metering provisions.	Y	5.0	REPORT/GP
Description of off-site required feeder mains, booster pumping stations, and other water infrastructure that will be ultimately required to service proposed development, including financing, interim facilities, and timing of implementation.	Y	3.0	REPORT/APPENDIX B
Confirmation that water demands are calculated based on the City of Ottawa Design Guidelines.	Y	REPORT	APPENDIX B-D
Provision of a model schematic showing the boundary conditions locations, streets, parcels, and building locations for reference.	Y	REPORT	APPENDIX D

Development Servicing Study Checklist

4.3 Wastewater	Addressed (Y/N/NA)	Section	Comments
Summary of proposed design criteria (Note: Wet-weather flow criteria should not deviate from the City of Ottawa Sewer Design Guidelines. Monitored flow data from relatively new infrastructure cannot be used to justify capacity requirements for proposed infrastructure).	Y	3 TO 5	APPENDIX B-D
Confirm consistency with Master Servicing Study and/or justifications for deviations.	NA		
Consideration of local conditions that may contribute to extraneous flows that are higher than the recommended flows in the guidelines. This includes groundwater and soil conditions, and age and condition of sewers.	Y	3.0	APPENDIX B
Description of existing sanitary sewer available for discharge of wastewater from proposed development.	Y	3.0	GP
Verify available capacity in downstream sanitary sewer and/or identification of upgrades necessary to service the proposed development. (Reference can be made to previously completed Master Servicing Study if applicable)	Y	REPORT	APPENDIX B
Calculations related to dry-weather and wet-weather flow rates from the development in standard MOE sanitary sewer design table (Appendix 'C') format.	NA		
Description of proposed sewer network including sewers, pumping stations, and forcemains.	Y	3 TO 5	REPORT
Discussion of previously identified environmental constraints and impact on servicing (environmental constraints are related to limitations imposed on the development in order to preserve the physical condition of watercourses, vegetation, soil cover, as well as protecting against water quantity and quality).	NA		
Pumping stations: impacts of proposed development on existing pumping stations or requirements for new pumping station to service development.	NA		
Forcemain capacity in terms of operational redundancy, surge pressure and maximum flow velocity.	NA		
Identification and implementation of the emergency overflow from sanitary pumping stations in relation to the hydraulic grade line to protect against basement flooding.	NA		
Special considerations such as contamination, corrosive environment etc.	NA		

Development Servicing Study Checklist

4.4 Stormwater	Addressed (Y/N/NA)	Section	Comments
Description of drainage outlets and downstream constraints including legality of outlet (i.e. municipal drain, right-of-way, watercourse, or private property).	Y	3 TO 5	REPORT, GP
Analysis of the available capacity in existing public infrastructure.	Y	REPORT	APPENDIX B
A drawing showing the subject lands, its surroundings, the receiving watercourse, existing drainage patterns and proposed drainage patterns.	Y	DWG'S	GR, STM
Water quantity control objective (e.g. controlling post-development peak flows to pre-development level for storm events ranging from the 2 or 5 year event (dependent on the receiving sewer design) to 100 year return period); if other objectives are being applied, a rationale must be included with reference to hydrologic analyses of the potentially affected subwatersheds, taking into account long-term cumulative effects.	Y	4.0	APPENDIX C
Water Quality control objective (basic, normal or enhanced level of protection based on the sensitivities of the receiving watercourse) and storage requirements.	Y	4.0	APPENDIX C
Description of stormwater management concept with facility locations and descriptions with references and supporting information.	Y	4.0	APPENDIX C
Set-back from private sewage disposal systems.	NA		
Watercourse and hazard lands setbacks.	NA		
Record of pre-consultation with the Ontario Ministry of Environment and the Conservation Authority that has jurisdiction on the affected watershed.	N/A		
Confirm consistency with sub-watershed and Master Servicing Study, if applicable study exists.	N		
Storage requirements (complete with calcs) and conveyance capacity for 5 yr and 100 yr events.	Y		APPENDIX D
Identification of watercourse within the proposed development and how watercourses will be protected, or, if necessary, altered by the proposed development with applicable approvals.	NA		
Calculate pre and post development peak flow rates including a description of existing site conditions and proposed impervious areas and drainage catchments in comparison to existing conditions.	Y	4.0	APPENDIX D
Any proposed diversion of drainage catchment areas from one outlet to another.	NA		
Proposed minor and major systems including locations and sizes of stormwater trunk sewers, and SWM facilities.	Y	DWG	GP
If quantity control is not proposed, demonstration that downstream system has adequate capacity for the post-development flows up to and including the 100-year return period storm event.	Y	REPORT	APPENDIX D

Development Servicing Study Checklist

4.4 Stormwater	Addressed (Y/N/NA)	Section	Comments
Identification of municipal drains and related approval requirements.	NA		
Description of how the conveyance and storage capacity will be achieved for the development.	Y	4.0	APPENDIX D
100 year flood levels and major flow routing to protect proposed development from flooding for establishing minimum building elevations (MBE) and overall grading.	Y	4.0	APPENDIX D
Inclusion of hydraulic analysis including HGL elevations.	Y	4.0	APPENDIX D
Description of approach to erosion and sediment control during construction for the protection of receiving watercourse or drainage corridors.	Y	DWG	ESC
Identification of floodplains – proponent to obtain relevant floodplain information from the appropriate Conservation Authority. The proponent may be required to delineate floodplain elevations to the satisfaction of the Conservation Authority if such information is not available or if information does not match current conditions.	N/A		
Identification of fill constrains related to floodplain and geotechnical investigation.	Y	2.0	REPORT

Development Servicing Study Checklist

4.5 Approval and Permit Requirements	Addressed (Y/N/NA)	Section	Comments
Conservation Authority as the designated approval agency for modification of floodplain, potential impact on fish habitat, proposed works in or adjacent to a watercourse, cut/fill permits and Approval under Lakes and Rivers Improvement Act. The Conservation Authority is not the approval authority for the Lakes and Rivers Improvement Act. Where there are Conservation Authority regulations in place, approval under the Lakes and Rivers Improvement Act is not required, except in cases of dams as defined in the Act.	NA		
Application for Certificate of Approval (CofA) under the Ontario Water Resources Act.	NA		
Changes to Municipal Drains.	NA		
Other permits (National Capital Commission, Parks Canada, Public Works and Government Services Canada, Ministry of Transportation etc.)	NA		

4.6 Conclusion	Addressed (Y/N/NA)	Section	Comments
Clearly stated conclusions and recommendations.	Y	6.0	REPORT
Comments received from review agencies including the City of Ottawa and information on how the comments were addressed. Final sign-off from the responsible reviewing agency.	NA		
All draft and final reports shall be signed and stamped by a professional Engineer registered in Ontario.	Y	ALL	ALL DWGS, REPORT