



STORMWATER MANAGEMENT AND SERVICEABILITY REPORT

REVISION 3 – LIB KANATA
KANATA AVENUE AND MARITIME WAY

CITY OF OTTAWA, ONTARIO

733, chemin Jean-Adam
Piedmont
(Québec) J0R 1R3

531, boulevard Manseau
Joliette
(Québec) J6E 3E3

495, rue Frontenac
Mont-Laurier
(Québec) J9L 2L3

T 450 227-1857
info@equipelaurence.ca
equipelaurence.ca

Piedmont
Boisbriand
Joliette
Mont-Laurier
Gatineau
Montréal
Rivière-Rouge



2022-07-12

ÉQUIPE LAURENCE INC.

File: 60.04.01

July 2022

PROJECT: REVISION 5 – LIB KANATA
Stormwater Management and Serviceability Report

FILE: 60.04.01

PREPARED BY:



Olivier Morrissey, P.Eng.
Équipe Laurence inc.



Lauren Menard, CEP
Équipe Laurence inc.

VERIFIED BY:



Benoit Bray, P.Eng.
Équipe Laurence inc.

PRESENTED TO: Groupe EMD – Bâtimo Inc.
6485, rue Doris-Lussier, suite 400
Boisbriand, QC
J7H 0E8 Canada

ISSUE: July 12th, 2022

TABLE OF CONTENTS

1.0	INTRODUCTION.....	1
2.0	STORMWATER MANAGEMENT	1
2.1	CALCULATION OF PRE-DEVELOPMENT FLOWS.....	2
2.2	DESIGN CRITERIA FOR POST-DEVELOPMENT FLOWS.....	3
2.3	CATCH BASIN SUB-AREAS.....	3
2.4	POST-DEVELOPMENT: UNCONTROLLED FLOWS	4
2.5	POST-DEVELOPMENT: CONTROLLED FLOWS AND STORAGE REQUIREMENTS.....	5
2.6	STORMWATER QUALITY	6
2.7	EROSION AND SEDIMENT CONTROL	6
3.0	SANITARY SEWER DESIGN FLOWS	7
3.1	POPULATION DENSITY.....	8
3.2	AVERAGE WASTEWATER FLOWS AND PEAKING FACTORS.....	8
3.3	EXTRANEOUS FLOWS.....	9
3.4	TOTAL SANITARY SEWER DESIGN FLOW	9
4.0	DOMESTIC WATER DEMAND.....	9
4.1	BOUNDARY CONDITIONS	11
5.0	REQUIRED FIRE DEMAND	12

APPENDICES

APPENDIX A: CIVIL ENGINEERING DRAWINGS

APPENDIX B: BACKGROUND DOCUMENTS

APPENDIX C: STORMWATER FLOWS AND STORAGE REQUIREMENTS – DETAILED CALCULATIONS

APPENDIX D: SANITARY SEWER DESIGN FLOWS – DETAILED CALCULATIONS

APPENDIX E: DOMESTIC WATER DEMAND – DETAILED CALCULATIONS

APPENDIX F: REQUIRED FIRE DEMAND – DETAILED CALCULATIONS

1.0 INTRODUCTION

This project consists of the residential development of Parcels 2, 3 and 5 located at the intersection of Kanata Avenue and Maritime Way, in the suburb of Kanata. Équipe Laurence Inc. was mandated to carry out the design of the drinking water, storm and sanitary sewer systems that serve the proposed building as well as the stormwater management report. The civil engineering plans depicting the general features of the site, such as the parking areas, sewer structures and landscaping is attached to this report in Appendix A.

In this report, the design and calculations of the sanitary sewer, domestic water and stormwater management systems will be discussed. The design was completed in accordance with the following design guidelines and regulations:

- Ottawa Sewer Design Guidelines (October 2012)
- *Technical memo* written by Justin Armstrong, Project Manager from the Planning, Infrastructure and Economic Development Department. File No. PC2021-0079
- *Stormwater Management Report Kanata Town Centre*, Volumes 1 & 2, prepared by J.L. Richards, (January 1999)

- Ottawa Design Guidelines – Water Distribution (July 2010)
- Ottawa Technical Bulletin ISTB-2018-02 (March 2018)
- Water Supply for Public Fire Protection, *Fire Underwriters Survey* (1999)

2.0 STORMWATER MANAGEMENT

As part of the stormwater management system, the flow of water will be controlled on-site and discharged through a 200 mm diameter service connection. This pipe will be connected to the existing 1625 mm diameter storm sewer on Maritime way as shown on the attached plans.

According to a complementary land survey completed by *Annis, O'Sullivan, Vollebekk Ltd.* on April 13, 2021, attached in Appendix B, the subject site is primarily occupied by forested areas. In addition, the elevation difference measured between the back of the lot and the property line along the road right-of-way varies between approximately 2 and 5 m.

For the design of the stormwater management system, the calculations were done to ensure that the post-development flows are equivalent to or lesser than the pre-development overland flow. Hence, the stormwater flows for the developed site as well as the storage requirements will be explored in the following sections.

2.1 Calculation of Pre-development Flows

The pre-development overland flow was determined using the criteria outlined in the *Ottawa Sewer Design Guidelines (2012)* as well as the following site information:

- The proposed site area of 1.599 hectares.
- The Rational Method for the calculation of flow as indicated in Section 5.4.4.1 of the design guideline.
- The IDF curves and equations as indicated in Section 5.4.2 of the design guideline.
- The runoff coefficients as shown in Table 5.7 of the design guideline.

The time of concentration for the pre-developed site is of 10 minutes and the runoff coefficients used are shown in the table below.

Table 1: Forested Area Runoff Coefficients for Various Storm Events

Storm Event	Runoff Coefficient For Forested Areas
5-yr	0.20
100-yr	0.25

Using these values, the pre-development overland flow is of 111.1 L/s and 237.9 L/s for the 5-yr and 100-yr storm, respectively. The detailed calculations are attached in Appendix C.

2.2 Design Criteria for Post-Development Flows

According to the *Technical Memo*, the allowable release rate to the minor system for the proposed site will be equivalent to the pre-development flow for the 5-year storm event. As mentioned in the previous section, the predevelopment flow for the 5-year storm is of 111.1 L/s. Moreover, it is mentioned that flows in excess of the 5-yr storm allowable release rate, up to and including the 100-yr storm event, must be retained on site. Hence, these storm events must be considered for the post-development flow calculations.

In addition, to account for the effects of climate change, a 20% increase will be added to the rainfall intensities for both the 5-yr and 100-yr storm events, as per the *Ottawa Sewer Design Guideline*.

2.3 Catch Basin Sub-Areas

The catch basins sub-areas are used to collect the stormwater from its associated area. The areas of impervious and pervious surfaces are determined for each catch basin. The catch basin sub-areas are depicted on drawing C-204 in Appendix A.

The runoff coefficients used for the post-development flow calculations for the 5-year storm event are shown in the table below. The 100-year runoff coefficients are determined by increasing the following coefficients by 25%, as per the *Ottawa Sewer Design Guideline*.

Table 2: Runoff Coefficients for Various Land Uses

Land Use	5-year Runoff Coefficient	100-year Runoff Coefficient
Forested area	0.20	0.25
Grass area	0.25	0.3125
Paved and roof areas	0.90	0.95

Using this information, the average runoff coefficients corresponding to both storm events are calculated. The results are shown in Table 3 and the detailed calculations are presented in Appendix C.

Table 3: Average Runoff Coefficients for the Various Catch Basin Sub-Areas

Drainage area	Total area (m ²)	5-year runoff coefficient	100-year runoff coefficient
CB-01	1187	0.507	0.557
CB-02	1408	0.545	0.595
CB-03	521	0.900	0.950
CB-04	1424	0.606	0.682
CB-05	526	0.900	0.950
CB-06	714	0.900	0.950
CB-07	558	0.900	0.950
CB-08	682	0.900	0.950
CB-09	422	0.900	0.950
CB-10	556	0.900	0.950
Building	5600	0.900	0.950
Total	13598	0.79	0.84

* The 100-year runoff coefficients are determined by increasing the 5-year runoff coefficients by 25% as per the city of Ottawa sewer design guidelines.

2.4 Post-Development: Uncontrolled Flows

For the proposed stormwater management system, there is an uncontrolled flow at the front of the building – i.e. on the surfaces parallel to the streets – as well as on the west side of the property. The total uncontrolled surface is of 2392 m², and the calculated time of concentration is of 10 minutes. Therefore, the uncontrolled flows for the 5-year and 100-year storm events are 51.2 L/s and 95.6 L/s, respectively.

To ensure that the proposed stormwater management system is sufficiently capable of managing the 100-year storm event and abides by the Ottawa Sewer Design Guideline, the uncontrolled flow for the 100-year storm will be subtracted from the allowable release rate of 111.1 L/s (5-year storm predevelopment flow), as calculated in Section 2.2, for the worst case scenario calculations of the controlled flows as well as the storage requirements. Therefore, the allowable release rate is of 15.5 L/s.

2.5 Post-Development: Controlled Flows and Storage Requirements

The controlled flows for the developed site as well as the required storage were calculated using the Rational Method. The detailed calculations are found in Appendix C.

Table 4: Storage Requirements for an Allowable Release Rate of 15.5 L/s, using the City of Ottawa IDF Curves

Storm Event	Time of Conc. (min)	Intensity (mm/hr)	Peak Flow (m ³ /s)	Max Volume (m ³)	Outgoing Volume (m ³)	Required Storage Volume (m ³)
5-yr	135.00	21.32	0.06	516.91	113.04	403.87
100-yr	250.00	22.07	0.07	1054.59	209.34	845.26

Therefore, to retain the 100-yr storm event as mentioned in Section 2.1, the required storage volume on site is of 845.3 m³.

The required storage will be retained partly on the roof of the proposed building as well as in the storm sewer structures and pipes. The remaining volume (600m³) will be stored in an underground concrete tank which will be located along the northwest side of the underground parking as shown on the C-203 drawing (Appendix A). The proposed stormwater storage distribution is shown in Table 5.

Table 5: Proposed Stormwater Storage

Description	Parameters	Values	Units
Proposed storage volume on roof, underground concrete tank and sewer structures	5-year required storage ¹	404	m ³
	100-year required storage ¹	845	m ³
	Maximum accumulation on roof (to be verified by mechanical engineer)	150	mm
	Volume retained on roof	261	m ³
	Volume retained in underground concrete tank	600	m ³
	Volume retained in sewer structures and pipes	10	m ³
	Total storage volume available	871	m³

1 - The rain intensity is increased by 20% as per the city of Ottawa sewer design guidelines to account for climate change.

The following items related to rooftop drainage will need to be completed by the mechanical and structural engineer responsible for the design:

- Flow Control Roof Drainage Declaration
- Design table that includes the rooftop storage details and calculations for the 2-year, 5 year and 100-year events.

2.6 Stormwater Quality

Low Impact Development (LID) Best Management Practices (BMPs) should be used wherever possible as part of the proposed development. LID measures such as bioretention, permeable pavement, tree conservation and green roofs are intended to address water quality and quantity concerns. Many of these measures can't be provided for this project due to development requirements and site constraints.

As mentioned by the MVCA (see Appendix B), the runoff from the site drains towards the KTC-SWMF which provides 70% TSS removal. This facility was designed taking into consideration future needs as described in the KTC – CBD SWM report (see Appendix B) prepared by J.L. Richards & Associates Limited. The following design criteria were applied when sizing the stormwater management facility:

- 70% TSS removal
- 130m³/ha water quality storage volume including:
 - 90m³/ha permanent pool volume
 - 40m³/ha extended detention storage

As mentioned in the *Technical Memo*, the controlled flows from the site are tributary to the Kanata Town Centre Stormwater Management Facility (KTC-SWMF), which is anticipated to provide the quality control for the site runoff. All other flows, such as the roof runoff and uncontrolled flows require no treatment considering no vehicular traffic is anticipated in these areas.

2.7 Erosion and Sediment Control

Prior to, during and after construction, the following erosion and sediment control measures should be implemented to avoid the sediment transfer to existing streams and storm sewer systems. These measures are listed on the drawing C-202 in Appendix A.

Pre-Construction

- Installation of a silt fence (geotextile)
- Installation of filter cloths over all existing manholes adjacent to construction zone
- Control measures to be inspected once installed
- Installation of a mud mat at the site access point

Construction

- Minimize the extent of disturbed areas
- Protect disturbed areas of runoff
- Provide cover if disturbed areas will not be reinstated within a reasonable period of time
- Inspect silt fence regularly during construction. Clean and repair, as required.
- Control dust during construction

After Construction

- Provide permanent cover to disturbed areas (i.e. topsoil and seed)
- Remove all temporary erosion and sediment control items (silt fence and filter cloths) once disturbed areas have been reinstated

Inspections

- Erosion and sediment control measures will be inspected upon completion
- Control measures are to be inspected weekly

All control measures are to be inspected once installed as well as during construction.

3.0 SANITARY SEWER DESIGN FLOWS

The proposed sanitary sewer service connection for the new building is 250 mm in diameter and made of PVC. This pipe will be connected to the existing 825 mm diameter municipal sewer pipe on Maritime Way.

The proposed sanitary system is designed in accordance with the City of Ottawa's Sewer Design Guidelines. The calculations for the proposed development flows are shown in the following sections.

3.1 Population Density

The population density of the proposed development is calculated using the number and type of housing units within this development. The detailed calculation is shown in Table 6.

Table 6: Population Density Calculation

Unit Types	Number of Units	Persons Per Unit	Population Density
1-bedroom	222	1.4	309.4
2-bedroom	152	2.1	317.1
3-bedroom	24	3.1	74.4
		<i>Total</i>	704

Using the values in Table 4.2 of the Sewer Design Guidelines for per unit populations, the population density of the proposed development is found to be 704 people. This value will be used in the following sections to determine the sewer design flows.

3.2 Average Wastewater Flows and Peaking Factors

The average wastewater flow for residential developments of 280 L/c/d is used to determine the average day demand for residential use. The new building will also include 1,484m² of commercial areas. According to the Sewer Design Guidelines, the average wastewater flow for commercial use is of 28,000 L/gross ha/d. Using this information, the total average wastewater flow for the proposed development is calculated below.

Average wastewater flow per capita for residential use: 280 L/c/d

Average wastewater flow for residential use: 197 232 L/d

Average wastewater flow for commercial use: 28,000 L/gross ha/d

Commercial areas: 1 214m² 3 399 L/d

The Harmon equation is then used to calculate the residential peak factor. Moreover, a peak factor of 1.50 is used for commercial areas.

$$P.F. = 1 + \left(\frac{14}{4 + \left(\frac{P}{1000} \right)^{1/2}} \right) \times K, \quad \text{where } K = 1$$

Hence, the peak factor for residential use is of 3.89.

3.3 Extraneous Flows

In accordance with Article 4.4.1.4 of the Sewer Design Guidelines, an allowance for flows from extraneous sources must be considered in the calculation of the peak design flow.

The average infiltration allowance is of 0.28 L/s/gross ha for wet-weather inflow into the manholes and pipes. Therefore, with a total site area of 1.599 ha, the infiltration flow is 0.45 L/s.

3.4 Total Sanitary Sewer Design Flow

Combining the results from the above calculations, the total sanitary sewer design flow is calculated as follows:

$$Q_{design} = [(3.89 \times 196\,252 \text{ L/d}) + (1.50 \times 3\,399 \text{ L/d})] \times \frac{1}{86\,400 \text{ sec/d}} + 0.45 \text{ L/s}$$
$$Q_{design} = 9.35 \text{ L/s}$$

The summary of this calculation is shown in Appendix D.

4.0 DOMESTIC WATER DEMAND

The proposed water service connection for the new building is 200 mm in diameter and made of PVC. This pipe will be connected to the existing 600 mm diameter municipal watermain on Maritime Way. A shutoff valve will be installed at the property line as per the City guidelines.

Moreover, the watermain will be looped and connected at the service entry to the building. An isolation valve will be installed between the two water service connections.

The proposed water system is designed in accordance with the City of Ottawa's Design Guidelines for water distribution. The calculations for the proposed water demand are shown in the following sections.

We can determine the average day demand for the proposed development using the values found in Table 4.2 of the Design Guidelines as the population density of the development was determined to be 704 people in Section 2.1. Hence, average day demands of 280 L/c/d and 28,000 L/gross ha/d are used for the residential and commercial spaces, respectively.

Average day demand per capita for residential use:	280 L/c/d
Average day demand for residential use:	197 232 L/d
Average day demand for other commercial use:	28,000 L/gross ha/d
Commercial Area: 1 214 m ²	3 399 L/d

Therefore, the total average day demand is:

$$Q_{avg,day} = \left(197\,232 \frac{L}{d} + 3\,399 L/d \right) \times \frac{1}{86,400} sec/d = 2.32 L/s$$

The maximum daily demand and the maximum hour demand are calculated using the factors found in Table 4.2 of the Design Guidelines.

$$Q_{max,day} = \left(2.5 \times 197\,232 \frac{L}{d} + 1.5 \times 3\,399 L/d \right) \times \frac{1}{86,400} sec/d = 5.77 L/s$$

$$Q_{max,hr} = \left(2.2 \times 2.5 \times 197\,232 \frac{L}{d} + 1.8 \times 1.5 \times 3\,399 L/d \right) \times \frac{1}{86,400} sec/d$$

$$Q_{max,hr} = 12.66 L/s$$

The detailed calculations for domestic water demand are found in Appendix E.

4.1 Boundary Conditions

This section presents the existing boundary conditions for the water distribution system for the connection sites identified in the figure below, as provided by the City of Ottawa. Note, this information is based on current operation of the city's water distribution system.



Figure 1: Service connection locations for the water distribution system (City of Ottawa)

Table 7: Connection 1 Located on Maritime Way (City of Ottawa)

Demand Scenario	Head (m)	Pressure (psi)
Maximum HGL	161.3	89.4
Peak Hour	156.3	82.3
Max Day + Fire Demand	153.2	78.0

Ground elevation at 98.4 m

Table 8: Connection 2 Located on Maritime Way (City of Ottawa)

Demand Scenario	Head (m)	Pressure (psi)
Maximum HGL	161.3	89.6
Peak Hour	156.3	82.5
Max Day + Fire Demand	153.2	78.1

Ground elevation at 98.3 m

It must be noted that the static pressure at any fixture shall not exceed 552 kPa (80 psi) according to the Ontario Building Code for areas that may be occupied. Hence, the following pressure control measures shall be considered:

1. If possible, the systems are to be designed to residual pressures 345 to 552 kPa (50 to 80 psi) for all occupied areas outside of the public right-of-way without special pressure control equipment.
2. Pressure reducing valves are to be installed immediately downstream of the isolation valve in the building, located downstream of the meter so that it is maintained by the owner.

These pressure control measures are presented in order of preference.

5.0 REQUIRED FIRE DEMAND

The flow rates required for fire protection vary according to the zoning, the type of units, the fire resistivity of the construction materials, the ground floor area as well as many other factors. The method described in *Water Supply for Public Fire Protection*, written by the Fire Underwriters Survey (FUS) (1999) is used to estimate the fire demand required for fire protection, as per the City Guidelines.

Essentially, the required flow rate (F), expressed in liters per minute, is calculated based on the floor area of the building (A) in square meters and the type of construction (C), using the following equation.

$$F = 220 \times C\sqrt{A}$$

The value of C used is 0.8 for a non-combustible construction. According to the FUS, a non-combustible construction is "any structure having all structural members including walls, columns, piers, beams, girders, trusses, floors and roofs made of non-combustible material and not qualifying as fire-resistive construction." In this case, the building will be full non-combustible construction both for the construction type and exterior cladding.

The value of A represents the gross floor area of the building, that is, the sum of the surface area of all floors. See in the table below that surface area of each floor.

Table 7: Gross Floor Area for the Proposed Development

Floor	Surface Area Per Floor (m ²)	Number of Floors	Floor Area (m ²)
Ground Floor	5 106	1	5 106
Levels 2-3	4 386	2	8 772
Levels 4-7	3 958	4	15 832
Levels 8-9	3 442	2	6 884
Level 10-11	1 337	2	2 754
<i>Total</i>			39 348

Finally, according to the FUS method, certain reductions and increases may be applied depending on a variety of factors such as the combustibility of the occupying materials or furniture, the presence of automatic sprinklers systems as well as the development's distance from neighbouring buildings. For example, for buildings protected by automatic sprinklers designed in accordance with the NPFA 13, the flow rate required for fire protection, F, can be reduced by 50%.

Using this method, the total fire demand was determined to be 18 000 L/min. Moreover, for a duration of water supply of 2 hours, the required volume of water is of 2,160 m³. The details of the fire flow calculations are shown in the Appendix F.

APPENDIX A

Civil Engineering Plans



PROJECT:

**LIB KANATA
KANATA AVENUE AND MARITIME WAY
CITY OF OTTAWA, ONTARIO**

PROJECT NO:

600401

DATE:

2022-07-12



160, boulevard de l'Hôpital, Gatineau (Québec) J8T 8J1
T 819 303 2700
info@equipelaurence.ca | equipelaurence.ca

**LIB KANATA - KANATA AVENUE AND MARITIME WAY
PROJET 600401 - PLANS ÉMIS FOR SITE PLAN APPLICATION REVISION 5, LE 2022-07-12**

007-12-21-0153

TECHNICAL AND GENERAL SPECIFICATIONS

1.0 GENERAL SPECIFICATIONS

All work shall conform with Ontario building code, latest edition as well as local regulation and bylaws.

Contractor to verify all dimensions and report any discrepancies to the engineer immediately to get design confirmation before proceeding with construction.

Refer to the City of Ottawa for regulations and standards (supersedes provincial standards).

Refer to Ontario Provincial Standards for Roads and Public Works - Volume 3 for details.

Ontario provincial standards for roads and public works must also be respected.

Work to be performed in accordance with the Occupational Health and Safety Act and Regulations for Construction Projects.

All materials shall meet all current applicable standards set by the American Water Works Association ("AWWA"), Canadian Standards Association ("CSA"), the American National Standards Institute ("ANSI") safety criteria standards, American Society for Testing and Materials (ASTM), NSF/14, NSF/60 and NSF/61.

The Contractor will get approval for all materials selection from the Civil Engineer prior to delivery to the site.

BUILDING OWNER: EMD BATIMO

CONSULTING CIVIL ENGINEER: ÉQUIPE LAURENCE INC.

2.0 GENERAL INFORMATIONS

2.1 UNDERGROUND SERVICES

The plans show certain underground installations for the sole purpose to highlight the existence of cables, pipelines and underground structures. In the sectors where work must be performed, the contractor is responsible to verify himself with the competent authorities the existence and actual location of all cables, pipelines and existing underground structures that may affect the works.

Before beginning excavations, the contractor must thus contact the Ontario One Call (www.on1call.com), the municipal authorities and all other stake holders in order to identify on the field all existing underground structures whether they are shown on the plans or not.

He is responsible for damages to cables, pipelines and underground structures. No cost variation resulting from underground structures not shown or poorly located on the plans can be claimed against the building owner. Following the review of the plans and specifications, the contractor must notify the engineer of any error, omission or discrepancy noted by him before starting work.

2.2 EXISTING WATERMAIN AND SEWER CONDUITS

The location of the watermain and sewer pipes is approximate. The contractor must verify and validate the position and depth of the pipes by the means of meticulous excavations. Should discrepancies be observed, they must be provided to the engineer without delay in order that the required modifications are made to the construction plans. The contractor will have to coordinate with the city, the connecting works to the existing networks (watermain and sewers). No service interruption shall take place without the building owner's authorization or the relevant authorities.

2.3 PROTECTION AGAINST EROSION

As per "Erosion and sediment control guideline for urban construction"
In all areas of the building site where there is a risk of erosion, the ground must be stabilized. Runoff water must be intercepted and routed to stabilized areas and this, throughout the construction period. The contractor must use the recognized methods to prevent the transport of sediments.

- Sediment barrier
- Mud mat
- Sedimentation pond
- Filtering berm and sediment trap
- Straw bale filter

Any intervention on the building site which may cause the transfer of sediments must be simultaneously accompanied by sediment capture measures.

2.4 DRAINING OF THE EXCAVATIONS

The contractor shall take all necessary precautions to prevent the penetration of surface waters and to evacuate surface, underground or sewer waters. Waste waters must be directed towards a combined sewer or a sanitary sewer and the surface and underground waters towards a storm sewer, a combined sewer or a ditch. In all cases, the diversion site must be submitted for approval.
The contractor must assume all required pumping and cleaning costs.

2.5 PAVEMENT PROTECTION

At all times, the movement of machinery and metal tracked vehicles is prohibited on paved surfaces unless plywood sheets with a 20mm normal thickness or rubber with a 12.5mm thickness are used in order to avoid damaging pavement. All repairs or complete replacements of pavement is the contractor's responsibility, who will have to pay all the costs.

2.6 CLEANING OF SITE

At the end of the construction works and as often as requested by the project superintendent, the contractor must clean and eliminate all construction generated debris and restore all construction affected areas. The cleaning of the construction site is included in the global market unit prices.

3.0 SITE GRADING

Surface topsoil layer stripping required.
Low-lying areas may be filled by utilising soil cut from higher areas and by importing suitable fill materials.

The approved subgrade may be raised to design subgrade level with approved compactable on-site soil, providing it is placed in maximum 300 mm thick lifts and each lift is compacted to at least 95% of the material's SPMDD. As an alternative to subexcavation, a woven geotextile separator, such as Terratrack 24-15, Amoco 2002, Mirafi 500XL or equivalent, may be placed over spongy areas prior to placing the Granular 'B' sub-base layer.

4.0 CONCRETE WORKS

All weather exposed concrete shall have 5 to 8% air entrainment or as otherwise specified in Tables 2 and 4 of CSA A23.1.

Concrete sidewalk as per OPSD 310.010. Foundation consist of 150 mm minimum of granular 'A' material. Sidewalk concrete thickness shall be 200 mm.

Concrete barrier curb as per OPSD 600.110. Foundation consist of 150 mm minimum of granular 'A' material.

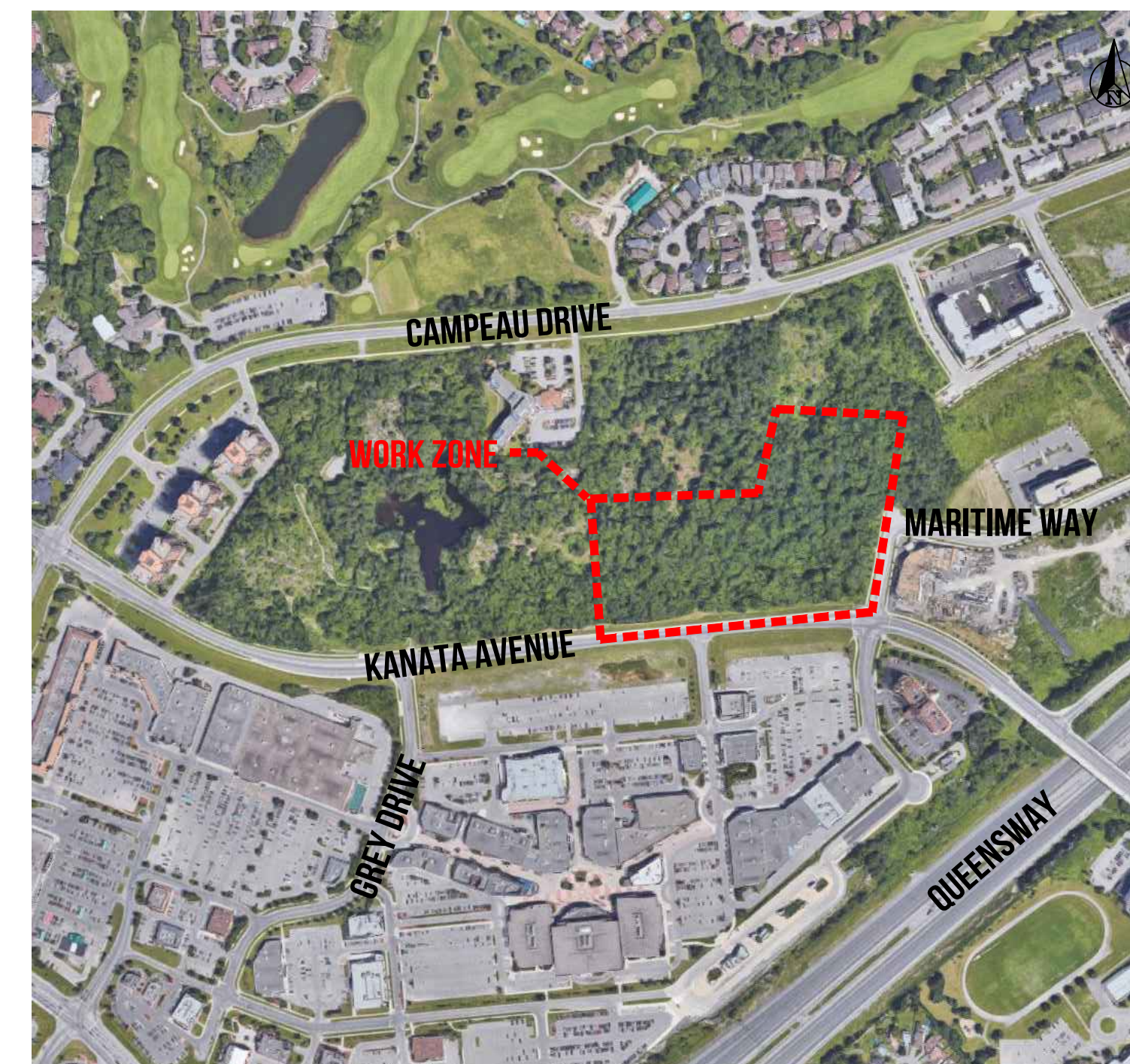

PROJECT LOCATION
NO SCALE

CIVIL ENGINEERING LEGEND

	EXISTING BUILDING
	PROPOSED BUILDING
	BOTTOM OF EMBANKMENT
	TOP OF EMBANKMENT
	DITCH CENTER
	DITCH TO BE REMOVED
	DITCH CENTER WITH ROCK FILL PROTECTION
	EXISTING FENCE
	FENCE TO BE REMOVED
	PROPOSED FENCE
	SILT FENCE BARRIER
	ISOLATED WETLAND
	EXISTING TREE
	WOODED AREA
	WOODED AREA TO BE REMOVED
	OVERLAND FLOW ROUTE
	GUARDRAIL
	STONE RETAINING WALL
	EXISTING FIRE HYDRANT
	PROPOSED FIRE HYDRANT
	EXISTING WATER SERVICE VALVE
	PROPOSED WATER SERVICE VALVE
	EXISTING WATER PIPE
	EXISTING WATER PIPE TO BE REMOVED
	PROPOSED WATER PIPE
	EXISTING DRINKING WATER SERVICE CONNECTION
	PROPOSED DRINKING WATER SERVICE CONNECTION
	EXISTING SANITARY SEWER AND MANHOLE
	PROPOSED SANITARY SEWER AND MANHOLE
	SANITARY SEWER AND MANHOLE TO BE REMOVED
	EXISTING STORM SEWER PIPE AND MANHOLE
	PROPOSED STORM SEWER PIPE AND MANHOLE
	STORM SEWER AND MANHOLE TO BE REMOVED
	CULVERT
	EXISTING CATCH BASIN OR MANHOLE-CATCH BASIN
	PROPOSED CATCH BASIN OR MANHOLE-CATCH BASIN
	EXISTING STORM SEWER MANHOLE
	PROPOSED STORM SEWER MANHOLE
	EXISTING SANITARY SEWER MANHOLE
	PROPOSED SANITARY SEWER MANHOLE
	LIGHTNING UNIT
	OVERHEAD WIRING AND GUY WIRE
	EXISTING GAS PIPELINE
	BELL CANADA UNDERGROUND CABLE
	UNDERGROUND ELECTRICAL WIRE
	PROPOSED ASPHALT SURFACE
	PROPOSED CONCRETE SIDEWALK/SLAB
	PAVER SIDEWALK
	PROPOSED GRASS SURFACE
	GRANULAR SURFACE
	PROPOSED TEMPORARY MUD MAT
	PROPOSED STONES SURFACE
	PROPOSED GRANITE STONES
	EXISTING ASPHALT SURFACE TO BE REMOVED
	EXISTING SURFACE TO BE REMOVED
	PROPOSED ELEVATION
	PROPOSED ELEVATION OF CONCRETE CURB
	PROPOSED ELEVATION OF CONCRETE SLAB
	PROPOSED TOP ELEVATION OF GRASS
	PROPOSED TOP ELEVATION OF SIDEWALK
	PROPOSED TOP ELEVATION OF RETAINING WALL
	PROPOSED BOTTOM ELEVATION OF RETAINING WALL
	EXISTING ELEVATION OF SURFACE
	GRADING SLOPES
	NORTH

LIST OF PLANS

C-201	TECHNICAL AND GENERAL SPECIFICATIONS, LEGEND AND NOTES LOCATION
C-202	PLAN VIEW EXISTING ITEMS, DEMOLITION AND EROSION AND SEDIMENT CONTROL PLAN
C-203	SITE GRADING PLAN
C-204	SITE SERVING PLAN AND DRAINAGE AREA
C-205	STANDARD SECTIONS AND DETAILS
C-206	STANDARD SECTIONS AND DETAILS II
C-207	FIRE HYDRANT COVERAGE MAP

F	FOR SITE PLAN APPLICATION REVISION 5	B.B	2022-07-12
E	FOR SITE PLAN APPLICATION REVISION 4	B.B	2022-07-07
D	FOR SITE PLAN APPLICATION REVISION 3	A.L.	2022-03-23
C	FOR SITE PLAN APPLICATION REVISION 2	A.L.	2021-10-07
B	FOR SITE PLAN APPLICATION REVISION 1	A.L.	2021-09-24
A	FOR SITE PLAN APPLICATION	A.L.	2021-09-17
REV	DESCRIPTION	BY	DATE



PROJECT:
LIB KANATA
KANATA AVENUE AND MARITIME WAY
CITY OF OTTAWA, ONTARIO



TITLE:
TECHNICAL AND GENERAL SPECIFICATIONS, LEGEND AND NOTES LOCATION

SCALE: NO SCALE

F.LACROIX, CPI	C-201.dwg
DESIGN	DRAWING
J.QUESNEL, DESSINATEUR	2021-09-14
DRAWN	DATE
B. BRAY, ING	600401
APPROVED	PROJECT NO
	PLAN NO

EROSION AND SEDIMENT CONTROL

PRE-CONSTRUCTION

- PRIOR TO ANY REMOVAL OF SOIL AND CONSTRUCTION.
- INSTALL SILT FENCE (GEOTEXTILE) AS NOTED
- INSTALL FILTER CLOTH OVER ALL EXISTING MANHOLES IN CONSTRUCTION ZONE.
- CONTROL MEASURES TO BE INSPECTED ONCE INSTALLED.
- CONSTRUCTION OF MUD MATS, SEE CONTRACTOR FOR LOCATION.

CONSTRUCTION

- MINIMIZE THE EXTENT OF DISTURBED AREAS.
- PROTECT DISTURBED AREAS OF RUNOFF.
- PROVIDE COVER (I.E. MULCH) IF DISTURBED AREAS WILL NOT BE REINSTATED WITHIN A REASONABLE PERIOD OF TIME.
- INSPECT SILT FENCE REGULARLY DURING CONSTRUCTION. CLEAN AND REPAIR, AS REQUIRED.
- CONTROL DUST DURING CONSTRUCTION.

AFTER CONSTRUCTION

- PROVIDE PERMANENT COVER TO DISTURBED AREAS (I.E. TOPSOIL AND SEED)
- REMOVE ALL TEMPORARY EROSION AND SEDIMENT CONTROL ITEMS (SILT FENCE AND FILTER CLOTHS) ONCE DISTURBED AREAS HAVE BEEN REINSTATED.

INSPECTIONS

- EROSION AND SEDIMENT CONTROL MEASURES WILL BE INSPECTED UPON COMPLETION.
- CONTROL MEASURES ARE TO BE INSPECTED WEEKLY.

CONTRACTOR TO BE RESPONSIBLE FOR INSTALLATION, INSPECTIONS AND MAINTENANCE OF ALL SEDIMENT AND EROSION CONTROL MEASURES.

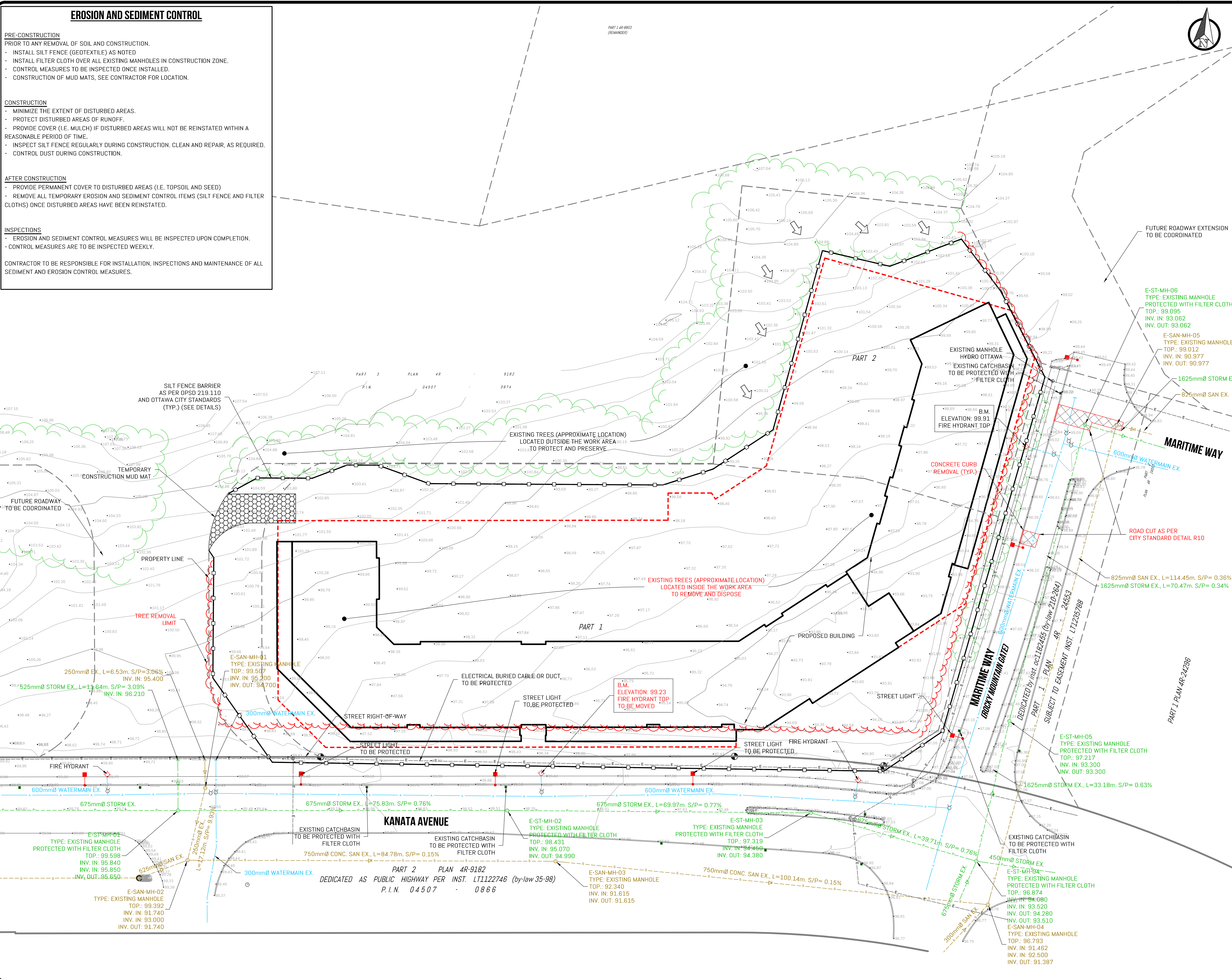

NOTE:
THE EXISTING AND PROPOSED SUBDIVISION WILL HAVE TO BE VALIDATED BY THE SURVEYOR-GEOMETER ON FILE.

SURVEY AND LOTS INFORMATION PROVIDED BY FARLEY, SMITH & DENIS SURVEYING LTD.
DATE: SEPTEMBER 13 2021
FILE NO.: 139-21
PLANIMETRIC REFERENCE SYSTEM: MTM NAD 83 ZONE 9
ALTIMETRIC REFERENCE SYSTEM: CGVD28 HT2.0

SITE PLAN PREPARED BY ROSSMANN ARCHITECTURE
DATE: SEPTEMBER 21 2021
PROJECT: 21019

EXISTING POWER DUCT BANK, WATERMAIN, STORM SEWER AND SANITARY SEWER FROM OTTAWA COORDINATING COMMITTEE CENTRAL REGISTRY AND CITY OF KANATA DEPARTMENT OF ENGINEERING

THE CONTRACTOR MUST NOTIFY ÉQUIPE LAURENCE, THE CONSULTANT, IF HE NOTICES ANY DISCREPANCIES BETWEEN THE INFORMATION PRESENTED ON THE PLANS AND THE MEASUREMENTS TAKEN ON SITE SO THAT ADJUSTMENTS CAN BE MADE.
WHEN APPLICABLE, HE MUST ALSO VERIFY THE ELEVATIONS OF EXISTING SEWERS BEFORE STARTING CONSTRUCTION AND MUST PROVIDE THE INFORMATION TO THE CONSULTANT.

REV	DESCRIPTION	BY	DATE
F	FOR SITE PLAN APPLICATION REVISION 5	B.B	2022-07-12
E	FOR SITE PLAN APPLICATION REVISION 4	B.B	2022-07-07
D	FOR SITE PLAN APPLICATION REVISION 3	A.L.	2022-03-23
C	FOR SITE PLAN APPLICATION REVISION 2	A.L.	2021-10-07
B	FOR SITE PLAN APPLICATION REVISION 1	A.L.	2021-09-24
A	FOR SITE PLAN APPLICATION	A.L.	2021-09-17



PROJECT: LIB KANATA
KANATA AVENUE AND MARITIME WAY
CITY OF OTTAWA, ONTARIO



TITLE: PLAN VIEW
EXISTING ITEMS, DEMOLITION AND
EROSION AND SEDIMENT CONTROL PLAN

SCALE: Horizontal 1:400

F.LACROIX, CPI	C-202.dwg
J.QUESNEL, DESSINATEUR	2021-09-14
B.BRAY, ING	DATE 600401
APPROVED	PROJECT NO C-202
	PLAN NO

F:\ed\projets\600401\5_Plans\C-202.dwg, 2022-07-12 12:18:58, kbarlier

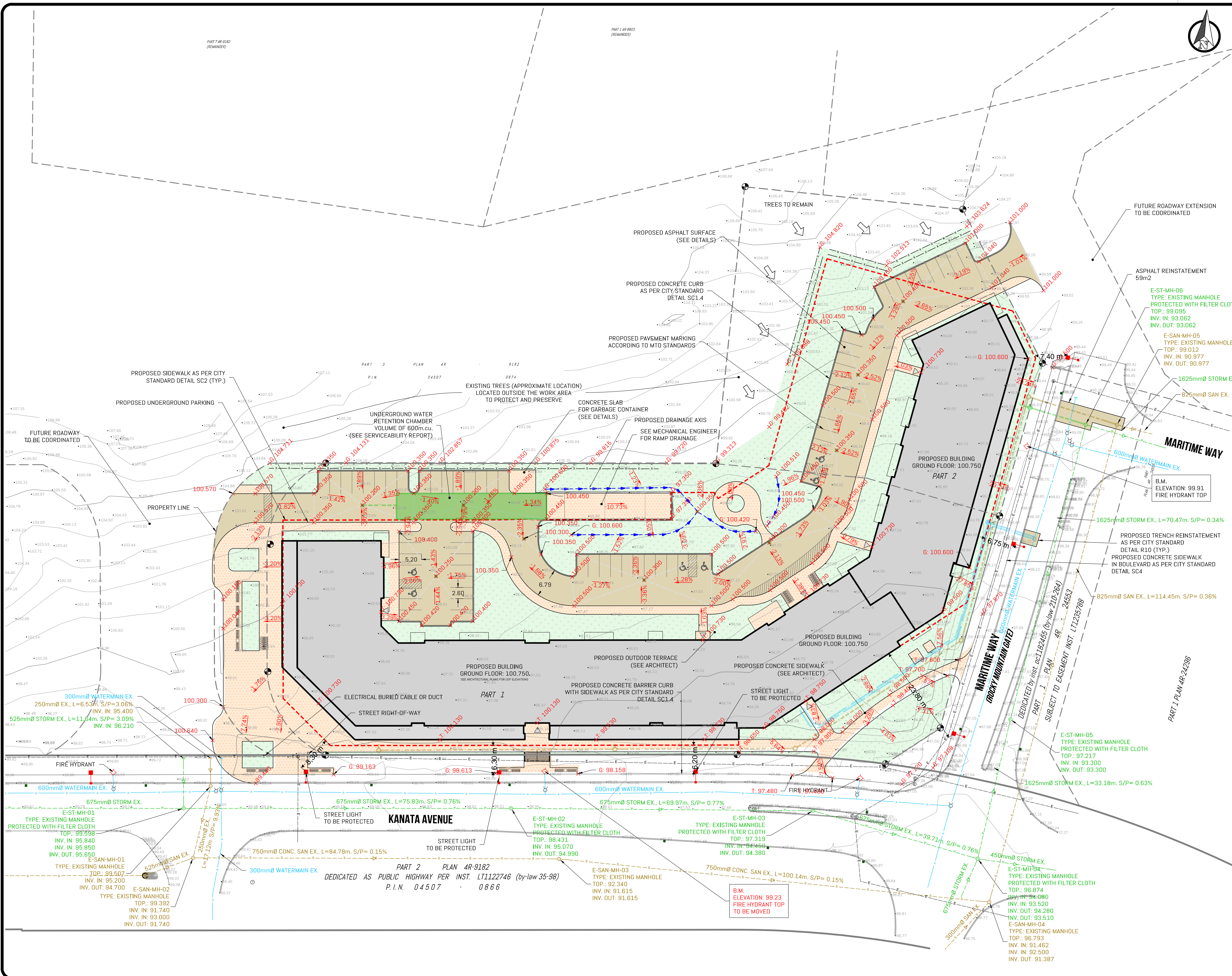

NOTE:
 THE EXISTING AND PROPOSED SUBDIVISION WILL HAVE TO BE VALIDATED BY THE SURVEYOR-GEOMETER ON FILE.

SURVEY AND LOTS INFORMATION PROVIDED BY FARLEY, SMITH & DENIS SURVEYING LTD.
 DATE: SEPTEMBER 13 2021
 FILE NO.: 139-21
 PLANIMETRIC REFERENCE SYSTEM: MTM NAD 83 ZONE 9
 ALTIMETRIC REFERENCE SYSTEM: CGVD28 HT2.0

SITE PLAN PREPARED BY
 ROSSMANN
 ARCHITECTURE
 DATE: AVRIL 21 2022
 PROJECT: 21019

EXISTING POWER DUCT BANK, WATERMAIN, STORM SEWER AND SANITARY SEWER FROM OTTAWA COORDINATING COMMITTEE CENTRAL REGISTRY AND CITY OF KANATA DEPARTMENT OF ENGINEERING

UNLESS OTHERWISE STATED, ALL PROPOSED ELEVATIONS SHOWN ON PLAN REPRESENT THE ELEVATION OF THE PAVEMENT SURFACE /PROJECTED TERRAIN.
 ADD 0.15m TO SEE THE ELEVATION OF THE SIDEWALK OR EJECTMENT

THE CONTRACTOR MUST NOTIFY ÉQUIPE LAURENCE, THE CONSULTANT, IF HE NOTICES ANY DISCREPANCIES BETWEEN THE INFORMATION PRESENTED ON THE PLANS AND THE MEASUREMENTS TAKEN ON SITE SO THAT ADJUSTMENTS CAN BE MADE.
 WHEN APPLICABLE, HE MUST ALSO VERIFY THE ELEVATIONS OF EXISTING SEWERS BEFORE STARTING CONSTRUCTION AND MUST PROVIDE THE INFORMATION TO THE CONSULTANT.

REV	DESCRIPTION	BY	DATE
F	FOR SITE PLAN APPLICATION REVISION 5	B.B	2022-07-12
E	FOR SITE PLAN APPLICATION REVISION 4	B.B	2022-07-07
D	FOR SITE PLAN APPLICATION REVISION 3	A.L.	2022-03-23
C	FOR SITE PLAN APPLICATION REVISION 2	A.L.	2021-10-07
B	FOR SITE PLAN APPLICATION REVISION 1	A.L.	2021-09-24
A	FOR SITE PLAN APPLICATION	A.L.	2021-09-17



PROJECT:
 LIB KANATA
 KANATA AVENUE AND MARITIME WAY
 CITY OF OTTAWA, ONTARIO

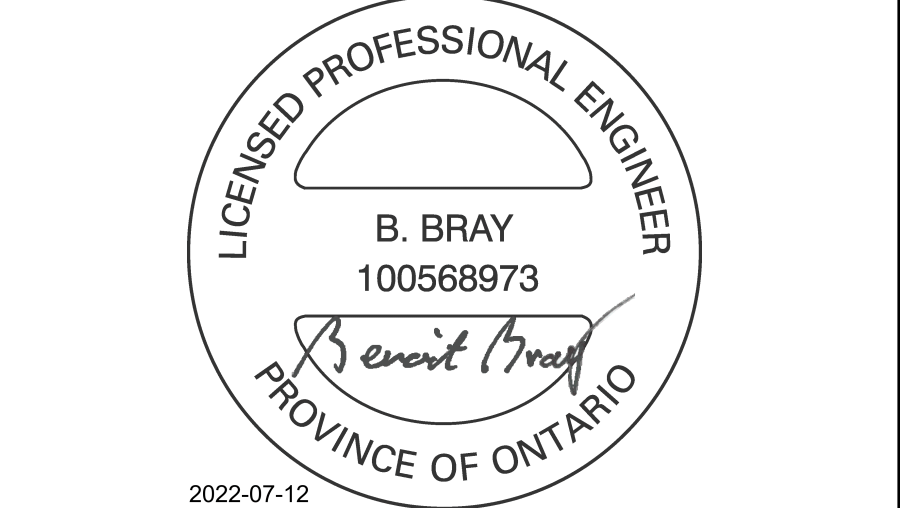
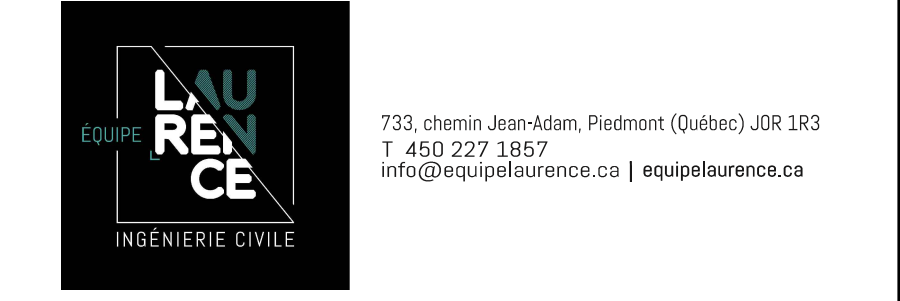

TITLE:
 SITE GRADING PLAN

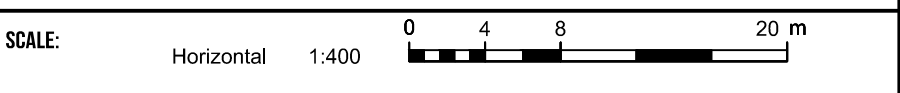

F.LACROIX, CPI	C-203.dwg
J.QUESNEL, DESSINATEUR	DRAWING 2021-09-14
B. BRAY, ING	DATE 600401
APPROVED	PROJECT NO C-203
	PLAN NO

STRUCTURE TABLE - STORM SEWER

NAME	DETAILS	ELEVATIONS/ INVERTS	RUNOFF COEFFICIENT (Cr)	SURFACE AREA (ha)
ST-MH-01	1200mm FLOWRATE REGULATOR	INV. IN: 97.680 INV. OUT: 97.680 SUMP: 97.230		
CB-01	SEE MECHANICAL	TOP: 100.450	0.557	0.119
CB-02	SEE MECHANICAL	TOP: 100.350	0.595	0.141
CB-03	SEE MECHANICAL	TOP: 100.350	0.950	0.052
CB-04	SEE MECHANICAL	TOP: 100.350	0.682	0.142
CB-05	SEE MECHANICAL	TOP: 100.300	0.950	0.053
CB-06	SEE MECHANICAL	TOP: 100.300	0.950	0.071
CB-07	SEE MECHANICAL	TOP: 100.300	0.950	0.056
CB-08	SEE MECHANICAL	TOP: 100.250	0.950	0.068
CB-09	600mm x 600mm UNDERGROUND TANK	TOP: 100.200 INV. OUT: 98.900 SUMP: 98.600	0.868	0.042
CB-10	600mm x 600mm	TOP: 100.200 INV. OUT: 98.900 SUMP: 98.600	0.827	0.056

STRUCTURE TABLE - SANITARY SEWER

NAME	DETAILS	ELEVATIONS/ INVERTS
SAN-MH-01	1200mm	INV. IN: 94.230 INV. OUT: 94.230
SAN-MH-02	915mm	INV. IN: 94.750 INV. OUT: 94.750
SAN-MH-03	915mm	INV. IN: 95.320 INV. OUT: 95.320
SAN-MH-04	915mm	INV. IN: 95.500 INV. OUT: 95.500
SAN-MH-05	915mm	INV. IN: 94.770 INV. OUT: 94.770

STORMWATER MANAGEMENT NOTES:

REFER TO "STORMWATER MANAGEMENT REPORT" PREPARED BY ÉQUIPE LAURENCE INC.

NOTE:

THE EXISTING AND PROPOSED SUBDIVISION WILL HAVE TO BE VALIDATED BY THE SURVEYOR-GEOMETER ON FILE.

SURVEY AND LOTS INFORMATION PROVIDED BY FARLEY, SMITH & DENIS SURVEYING LTD.
DATE: SEPTEMBER 13 2021
FILE NO.: 139-21
PLANIMETRIC REFERENCE SYSTEM: MTM NAD 83 ZONE 9
ALTIMETRIC REFERENCE SYSTEM: CGVD28 HT2.0

SITE PLAN PREPARED BY ROSSMANN ARCHITECTURE
DATE: AVRIL 21 2022
PROJECT: 210119

EXISTING POWER DUCT BANK, WATERMAIN, STORM SEWER AND SANITARY SEWER FROM OTTAWA COORDINATING COMMITTEE CENTRAL REGISTRY AND CITY OF KANATA DEPARTMENT OF ENGINEERING

THE CONTRACTOR MUST NOTIFY ÉQUIPE LAURENCE, THE CONSULTANT, IF HE NOTICES ANY DISCREPANCIES BETWEEN THE INFORMATION PRESENTED ON THE PLANS AND THE MEASUREMENTS TAKEN ON SITE SO THAT ADJUSTMENTS CAN BE MADE.
WHEN APPLICABLE, HE MUST ALSO VERIFY THE ELEVATIONS OF EXISTING SEWERS BEFORE STARTING CONSTRUCTION AND MUST PROVIDE THE INFORMATION TO THE CONSULTANT.

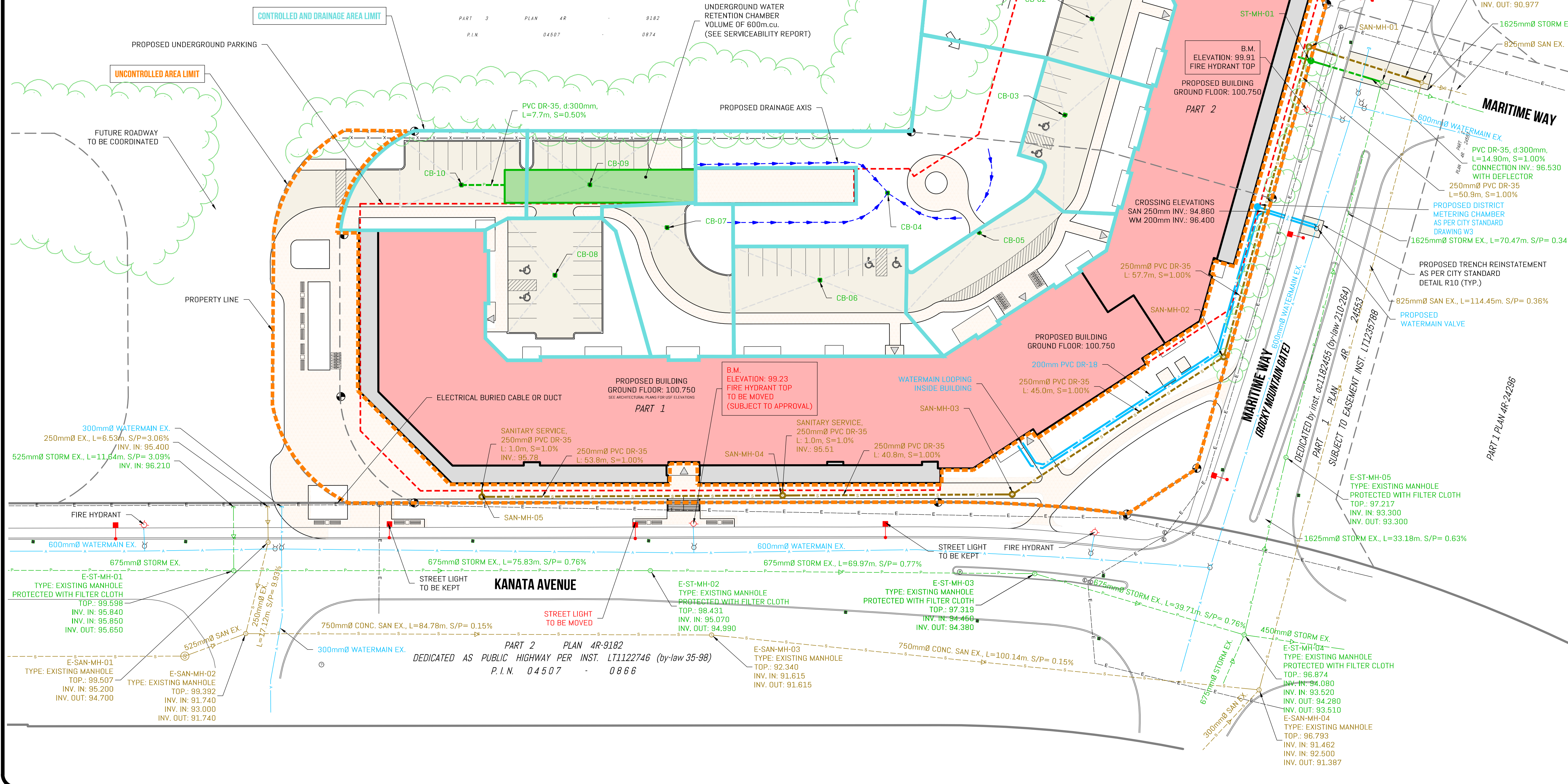

REV	DESCRIPTION	BY	DATE
F	FOR SITE PLAN APPLICATION REVISION 5	B.B	2022-07-12
E	FOR SITE PLAN APPLICATION REVISION 4	B.B	2022-07-07
D	FOR SITE PLAN APPLICATION REVISION 3	A.L.	2022-03-23
C	FOR SITE PLAN APPLICATION REVISION 2	A.L.	2021-10-07
B	FOR SITE PLAN APPLICATION REVISION 1	A.L.	2021-09-24
A	FOR SITE PLAN APPLICATION	A.L.	2021-09-17

CLIENT: **emo batimo**
CONSTRUCTION PROMOTEUR ET GESTIONNAIRE IMMOBILIER

PROJECT: LIB KANATA
KANATA AVENUE AND MARITIME WAY
CITY OF OTTAWA, ONTARIO

ÉQUIPE LAURENCE
INGÉNIEURIE CIVILE
733, chemin Jean-Jacques, Piedmont (Dorval) J0R 1R3
T 450 227 1857
info@equipe-laurence.ca | equipe-laurence.ca

LICENSED PROFESSIONAL ENGINEER
B. BRAY
100568973
PROVINCE OF ONTARIO
2022-07-12

TITLE: SITE SERVICING PLAN AND DRAINAGE AREA

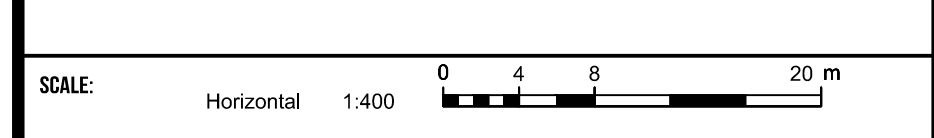

F.LACROIX, CPI	C-204.dwg
J.QUESNEL, DESSINATEUR	DRAWING 2021-09-14
B. BRAY, ING	DATE 600401
APPROVED	PROJECT NO C-204
	PLAN NO

file:///projets/600401/Plans/C-204.dwg, 2022-07-12 12:19:25, 192bits

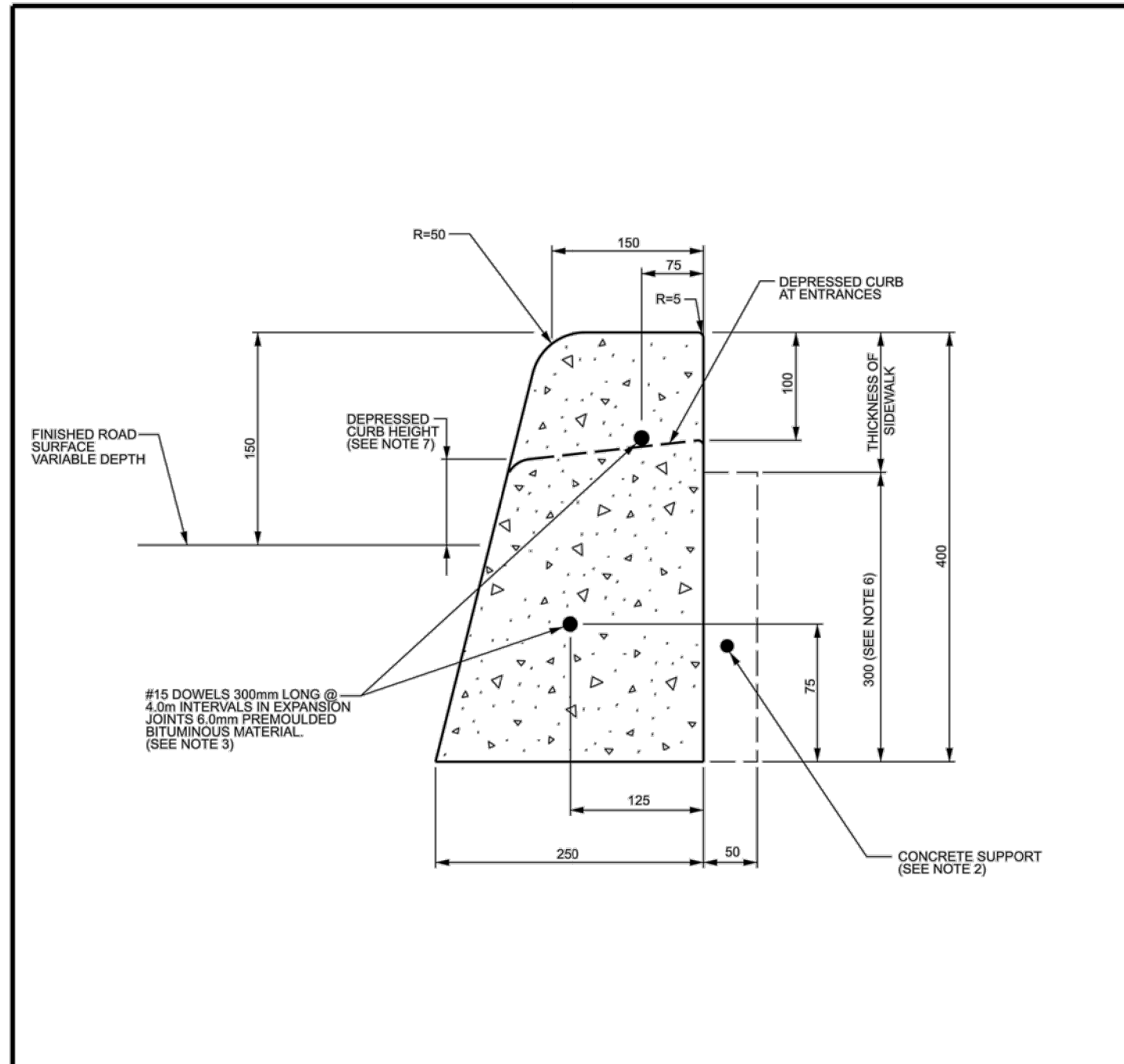

CONCRETE BARRIER CURB

- NOTES:
1. THE FULL CURB DEPTH SHALL BE CARRIED THROUGH THE DEPRESSED ACCESS CROSSING.
 2. A CONCRETE SUPPORT IS REQUIRED WHEN BUILT ADJACENT TO THE SIDEWALK.
 3. IF AN EXTRUSION CURBING MACHINE IS USED, THE EXPANSION BITUMINOUS MATERIAL AND THE #15 DOWELS ARE TO BE PLACED AT THE END OF THE EXTRUSION.
 4. ALL DIMENSIONS ARE IN MILLIMETRES UNLESS SHOWN OTHERWISE.
 5. DUMMY JOINTS SHALL BE 25mm DEEP, FRONT, BACK AND TOP OF SECTION AT 4m SPACING OR MATCH JOINTING WHERE SIDEWALK IS ADJACENT.
 6. FOR DEPRESSED CURB AT ENTRANCES USE 250.
 7. DEPRESSED CURB HEIGHT - FOR PEDESTRIAN CURB RAMPS 0 TO 6 mm AND FOR PRIVATE ENTRANCES 0 TO 13mm.

N.T.S.

	CONCRETE BARRIER CURB FOR GRANULAR BASE PAVEMENT (MODIFIED OPSD-600.110)		DATE: JANUARY 2003
	REV. DATE: MARCH 2021		
	DWG. No.: SC1.1		

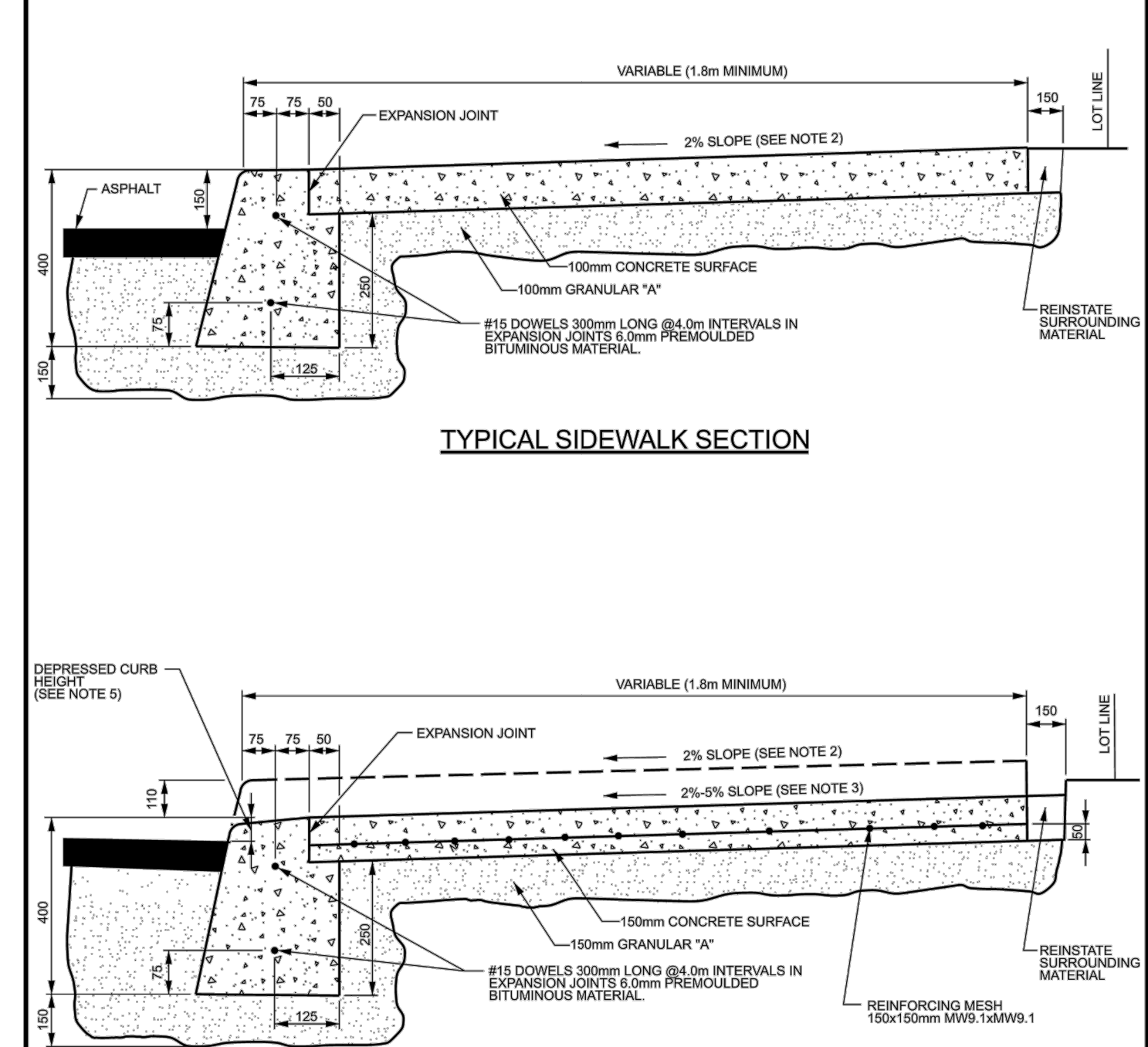

TYPICAL SIDEWALK SECTION

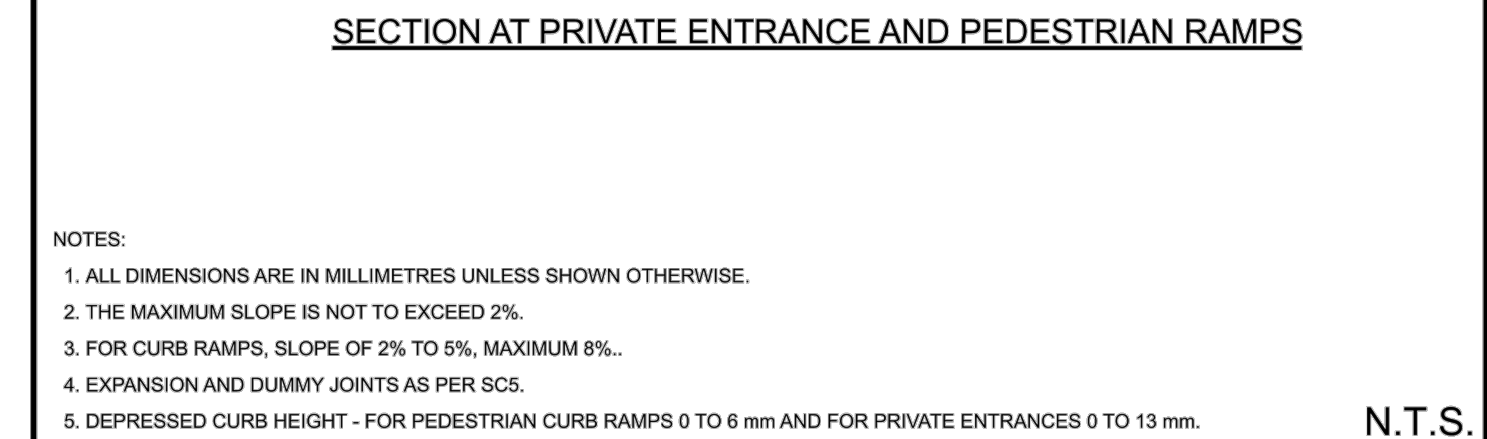

SECTION AT PRIVATE ENTRANCE AND PEDESTRIAN RAMPS

- NOTES:
1. ALL DIMENSIONS ARE IN MILLIMETRES UNLESS SHOWN OTHERWISE.
 2. THE MAXIMUM SLOPE IS NOT TO EXCEED 2%.
 3. FOR CURB RAMPS, SLOPE OF 2% TO 5%, MAXIMUM 8%.
 4. EXPANSION AND DUMMY JOINTS AS PER SCS.
 5. DEPRESSED CURB HEIGHT - FOR PEDESTRIAN CURB RAMPS 0 TO 6 mm AND FOR PRIVATE ENTRANCES 0 TO 13 mm.

N.T.S.

	CONCRETE BARRIER CURB WITH SIDEWALK		DATE: JANUARY 2003
	REV. DATE: MAY 2021		
	DWG. No.: SC1.4		

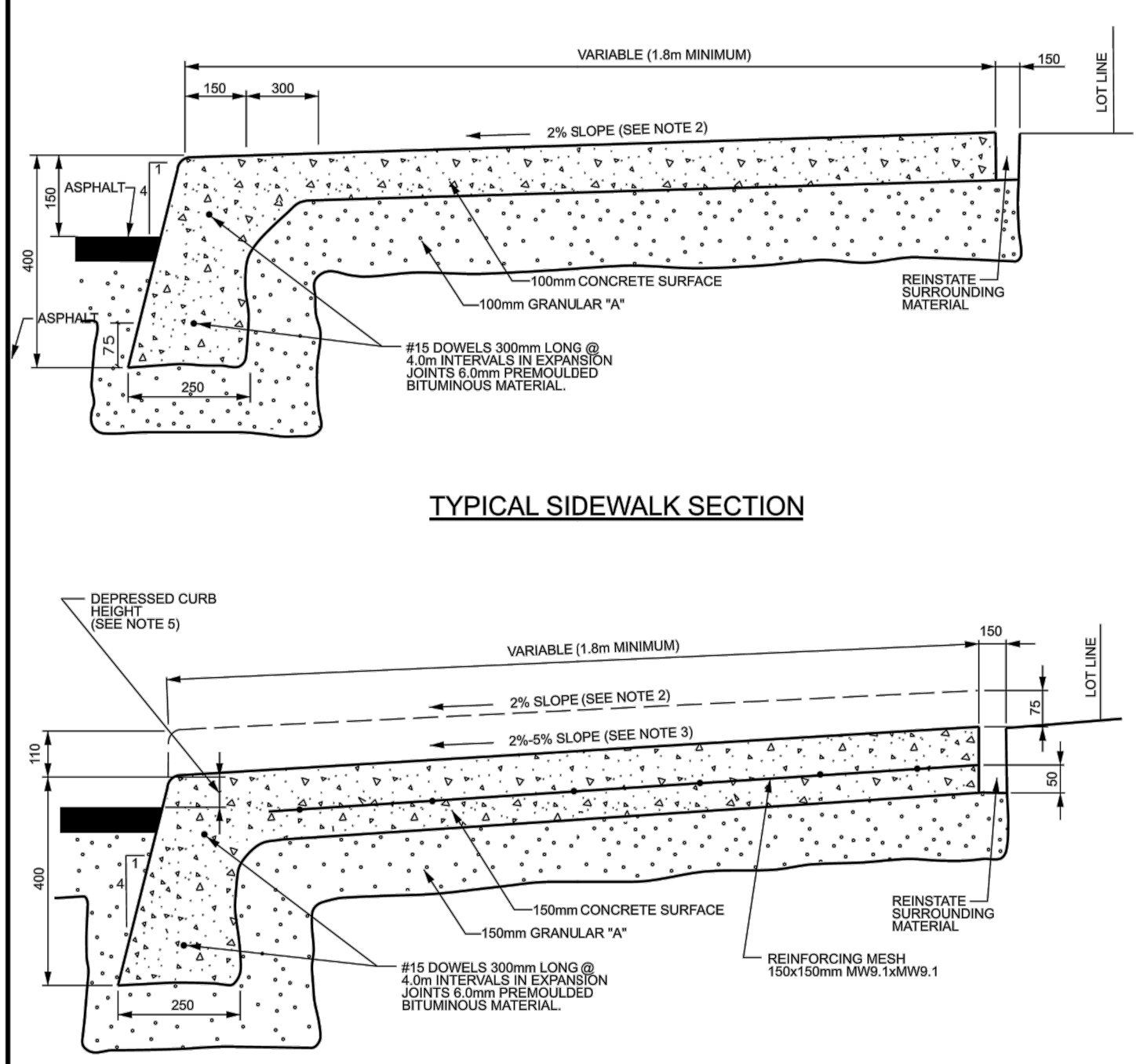

TYPICAL SIDEWALK SECTION

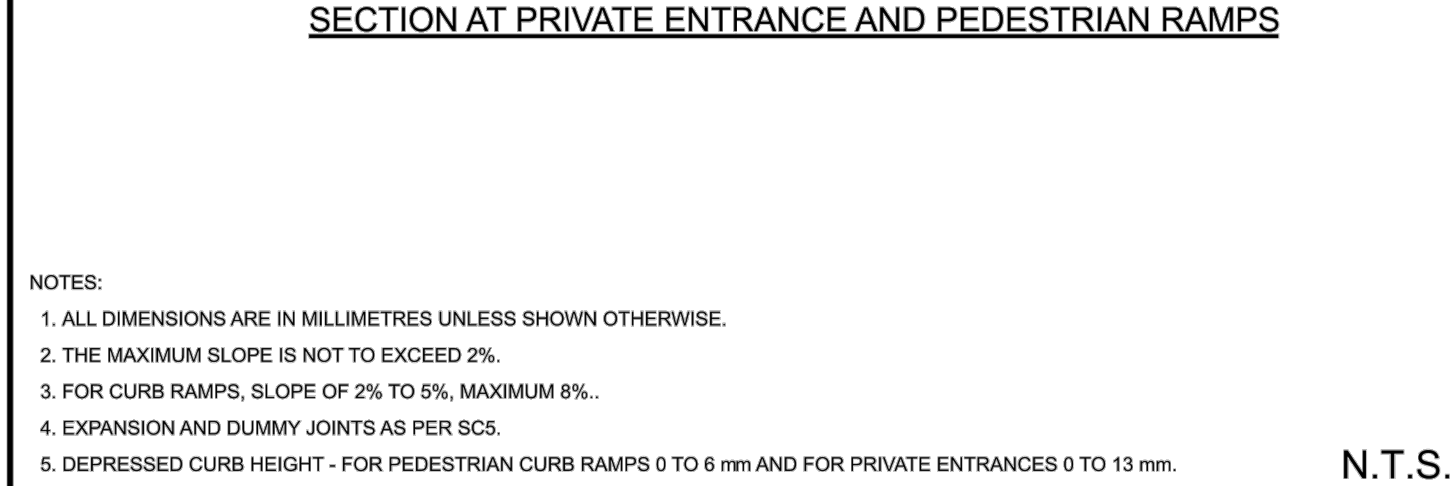

SECTION AT PRIVATE ENTRANCE AND PEDESTRIAN RAMPS

- NOTES:
1. ALL DIMENSIONS ARE IN MILLIMETRES UNLESS SHOWN OTHERWISE.
 2. THE MAXIMUM SLOPE IS NOT TO EXCEED 2%.
 3. FOR CURB RAMPS, SLOPE OF 2% TO 5%, MAXIMUM 8%.
 4. EXPANSION AND DUMMY JOINTS AS PER SCS.
 5. DEPRESSED CURB HEIGHT - FOR PEDESTRIAN CURB RAMPS 0 TO 6 mm AND FOR PRIVATE ENTRANCES 0 TO 13 mm.

N.T.S.

	MONOLITHIC CONCRETE CURB AND SIDEWALK		DATE: MAY 2001
	REV. DATE: MAY 2021		
	DWG. No.: SC2		

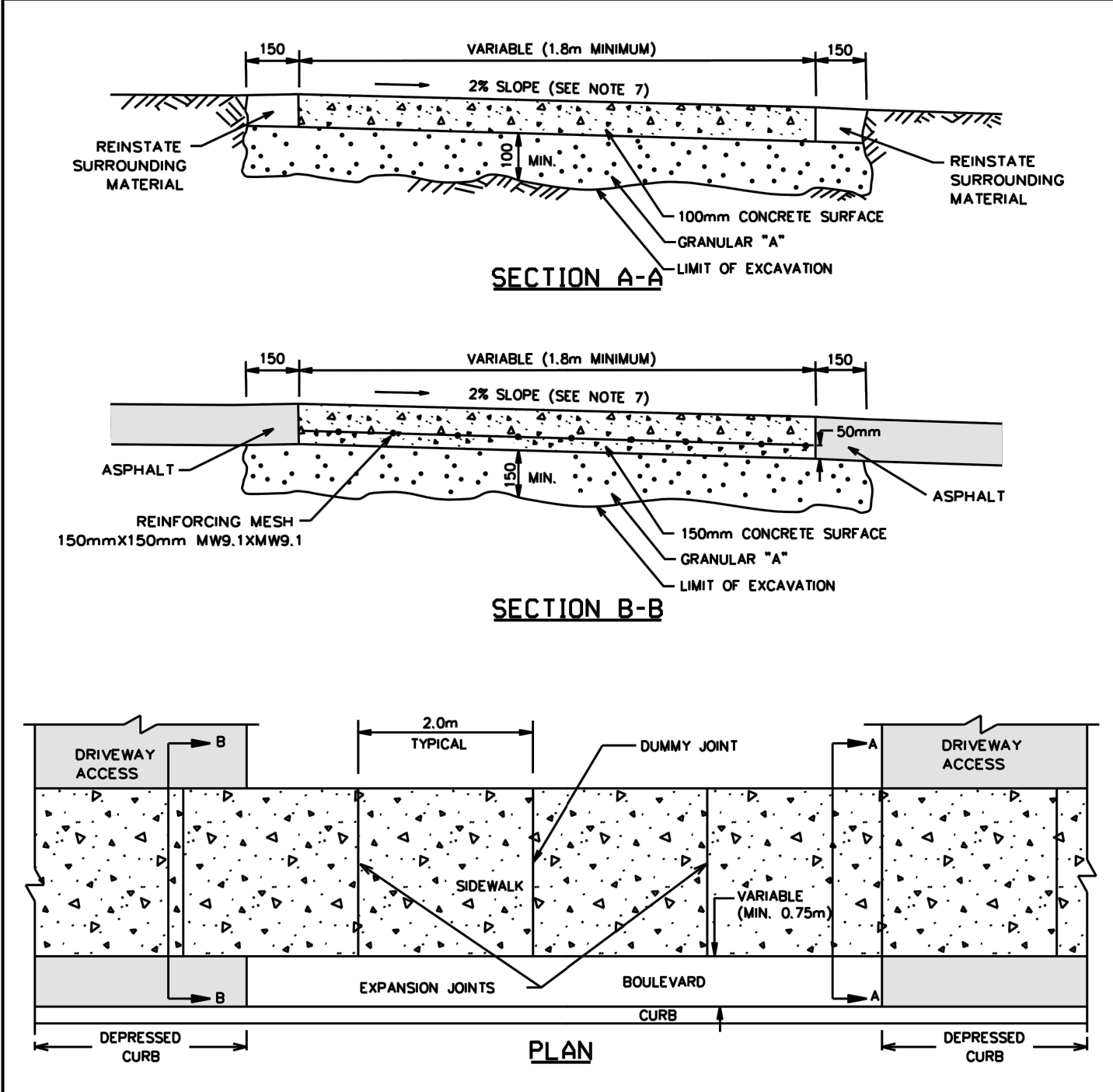

SECTION A-A

SECTION B-B

PLAN

- NOTES:
1. CONCRETE AND GRANULAR 'A' IS TO BE INCREASED TO 150mm AT THE ENTRANCE AND 150x150mm MW9.1 x MW9.1 REINFORCING MESH IS TO BE PLACED MID DEPTH WITHIN DRIVEWAY ACCESS.
 2. TRANSVERSE EXPANSION JOINTS ARE REQUIRED AT THE ENDS, THE MIDPOINT, AT INTERVALS OF 4m MAXIMUM, AND ALSO TO ISOLATE OBSTRUCTIONS FROM SIDEWALK, HYDRANTS, POLES, BUILDINGS, ETC.
 3. WHEN THE OVERALL SIDEWALK WIDTH EXCEEDS 2.5m, A LONGITUDINAL CONSTRUCTION JOINT SHALL BE CREATED AT ITS MIDPOINT.
 4. EDGES AND JOINTS ARE TO BE FINISHED WITH A 75mm EDGING TOOL.
 5. ALL CONCRETE SIDEWALKS ARE TO HAVE A BROOM FINISH UNLESS OTHERWISE SPECIFIED.
 6. ALL DIMENSIONS ARE IN MILLIMETRES UNLESS SHOWN OTHERWISE.
 7. THE MAXIMUM SLOPE IS NOT TO EXCEED 2%.
 8. INSTALL DUMMY TRANSVERSE JOINTS AS REQUIRED SO THERE IS A MAXIMUM SPACING OF 2m BETWEEN ALL JOINTS.
 9. SIDEWALK NOT TO BE DEPRESSED ACROSS DRIVEWAY ACCESSES.
 10. EXPANSION AND DUMMY JOINTS AS PER SCS

DATE: MAY 2001
REV. DATE: MARCH 2016
DWG. No.: SC4

	TYPICAL CONCRETE SIDEWALK IN BOULEVARD		DATE: MAY 2001
	REV. DATE: MARCH 2016		
	DWG. No.: SC4		

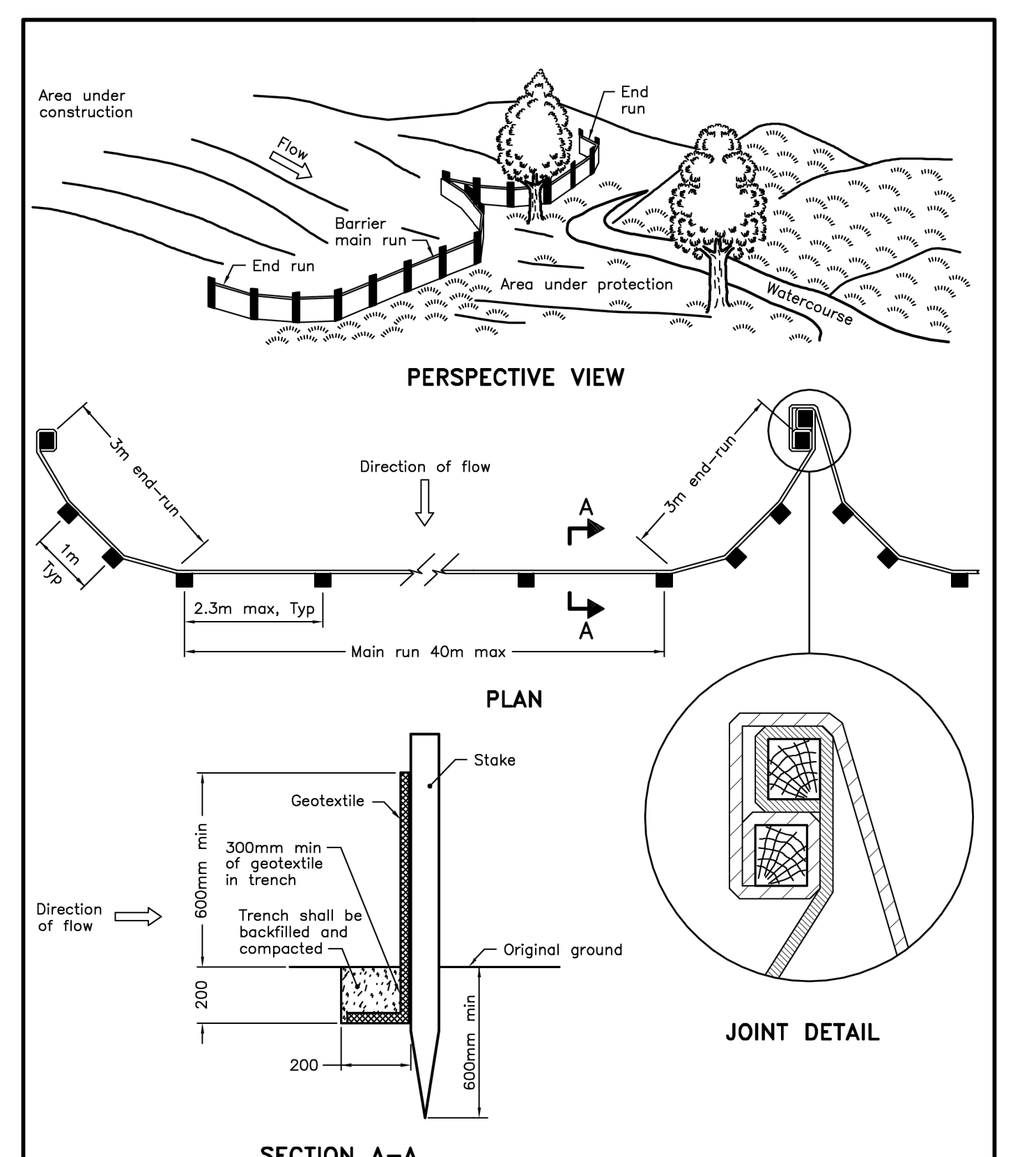

PERSPECTIVE VIEW

PLAN

JOINT DETAIL

- NOTE:
- A All dimensions are in millimetres unless otherwise shown.

ONTARIO PROVINCIAL STANDARD DRAWING		Nov 2015	Rev 2	
LIGHT-DUTY SILT FENCE BARRIER		OPSD 219.110		

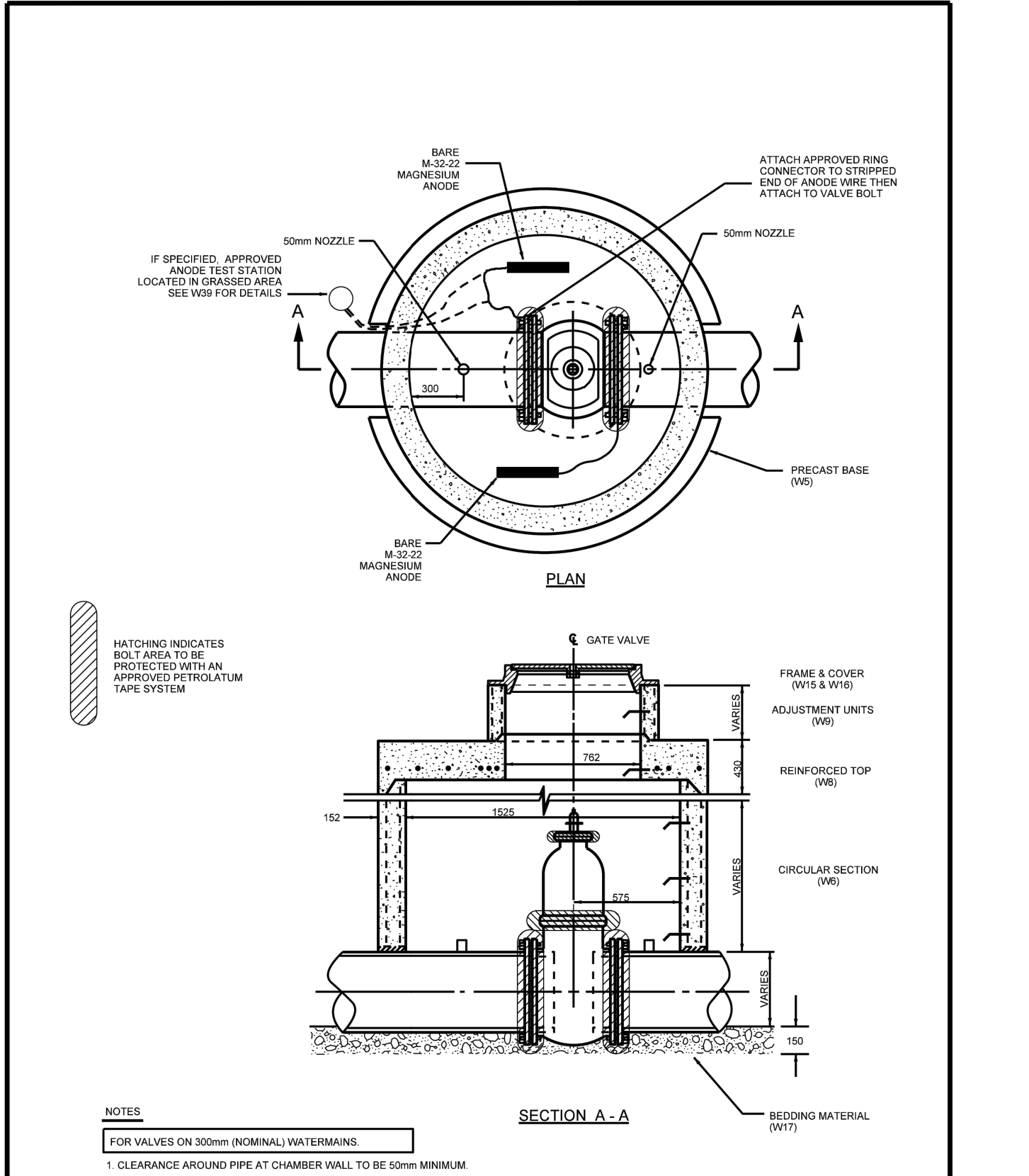

PLAN

SECTION A-A

- NOTES:
1. CLEARANCE AROUND PIPE AT CHAMBER WALL TO BE 50mm MINIMUM.
 2. VALVE CHAMBERS IN USE OF BOXES ON WATERMAINS SMALLER THAN 300mm ONLY TO BE USED, IF APPROVED BY THE CONTRACT ADMINISTRATOR.
 3. REFER TO MW-13.1 FOR ADDITIONAL REQUIREMENTS.
 4. REFER TO MW-18.15 FOR APPROVED MANUFACTURERS.
 5. ALL DIMENSIONS ARE IN MILLIMETRES UNLESS SHOWN OTHERWISE.
 6. CATHODIC PROTECTION MEASURES SHALL BE INSTALLED IN ACCORDANCE WITH MW9, MW10 AND MW12.
 7. TRACER WIRE REQUIRED FOR P.C. RIS AND HOPE WATERMAIN PIPE ONLY AS PER MW9. TRACER WIRE TO BE CONNECTED TO VALVE BOLT AS PER MW5 AND SECURED TO TOP OF CHAMBER.

DATE: MAY 2001
REV. DATE: MARCH 2021
DWG. No.: W3

	CIRCULAR CHAMBER GATE VALVES		DATE: MAY 2001
	REV. DATE: MARCH 2021		
	DWG. No.: W3		

REV	DESCRIPTION	BY	DATE
F	FOR SITE PLAN APPLICATION REVISION 5	B.B	2022-07-12
E	FOR SITE PLAN APPLICATION REVISION 4	B.B	2022-07-07
D	FOR SITE PLAN APPLICATION REVISION 3	A.L.	2022-03-23
C	FOR SITE PLAN APPLICATION REVISION 2	A.L.	2021-10-07
B	FOR SITE PLAN APPLICATION REVISION 1	A.L.	2021-09-24
A	FOR SITE PLAN APPLICATION	A.L.	2021-09-17

CLIENT:

CONSTRUCTION PROMOTEUR ET GESTIONNAIRE IMMOBILIER

PROJECT:

LIB KANATA
KANATA AVENUE AND MARITIME WAY
CITY OF OTTAWA, ONTARIO

INGENIERIE CIVILE

733, chemin Jean-Jacques, Piedmont (Dobac) J0R 1R3
T. 450 227 1857
info@equipe-laurence.ca | equipe-laurence.ca

LICENSED PROFESSIONAL ENGINEER
B. BRAY
100568973
PROVINCE OF ONTARIO
2022-07-12

TITLE:

STANDARD SECTIONS AND DETAILS

SCALE:

NO SCALE

F.LACROIX, CPI	C-205.dwg
J.QUESNEL, DESSINATEUR	DRAWING
B. BRAY, ING	2021-09-14
	DATE
600401	C-205
	PROJECT NO
	PLAN NO

D07-12-21-0153

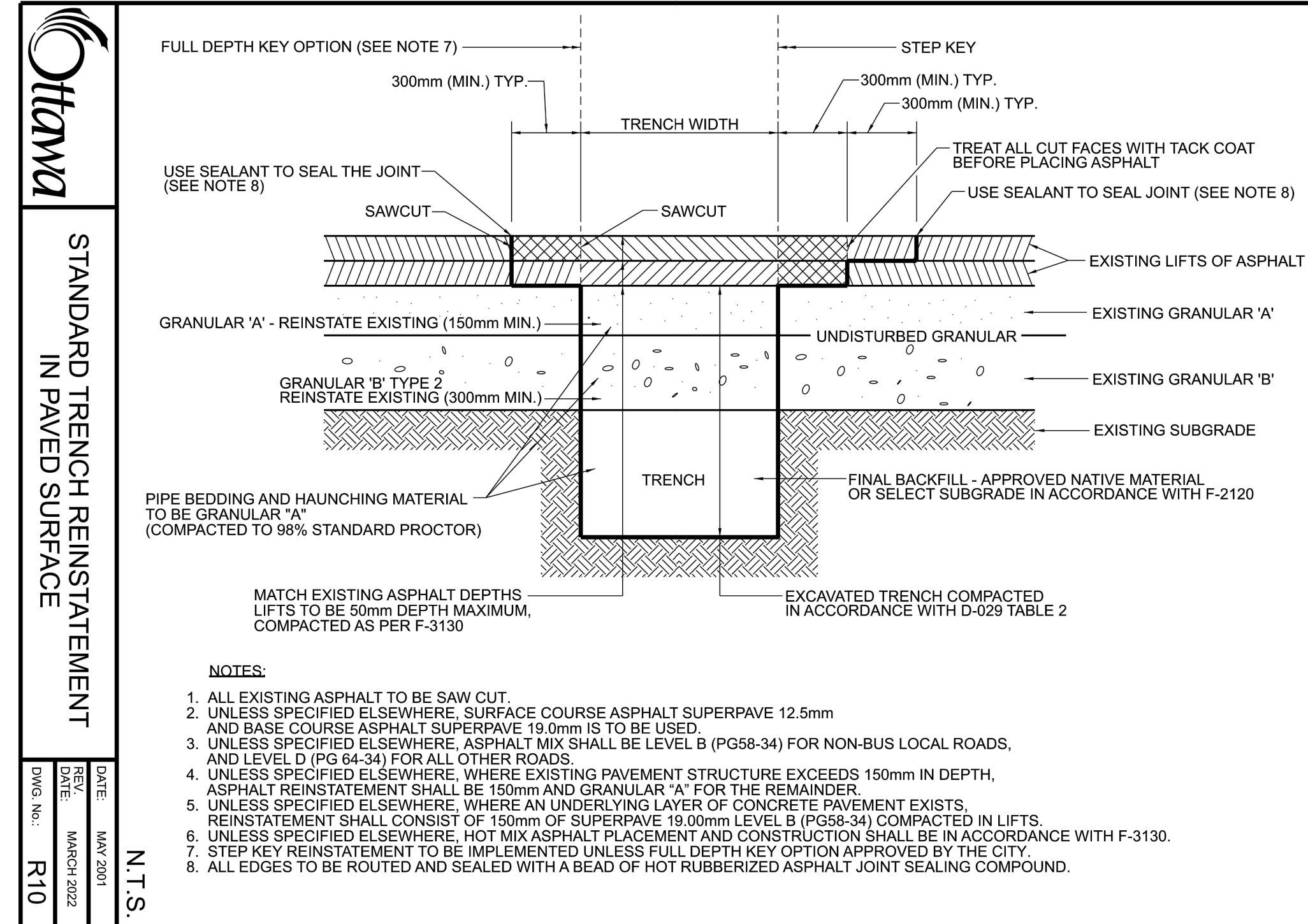

OTTAWA
STANDARD TRENCH REINSTATEMENT
IN PAVED SURFACE
DATE: MAY 2001
REVISED: MARCH 2022
DWS: R10
N.T.S.

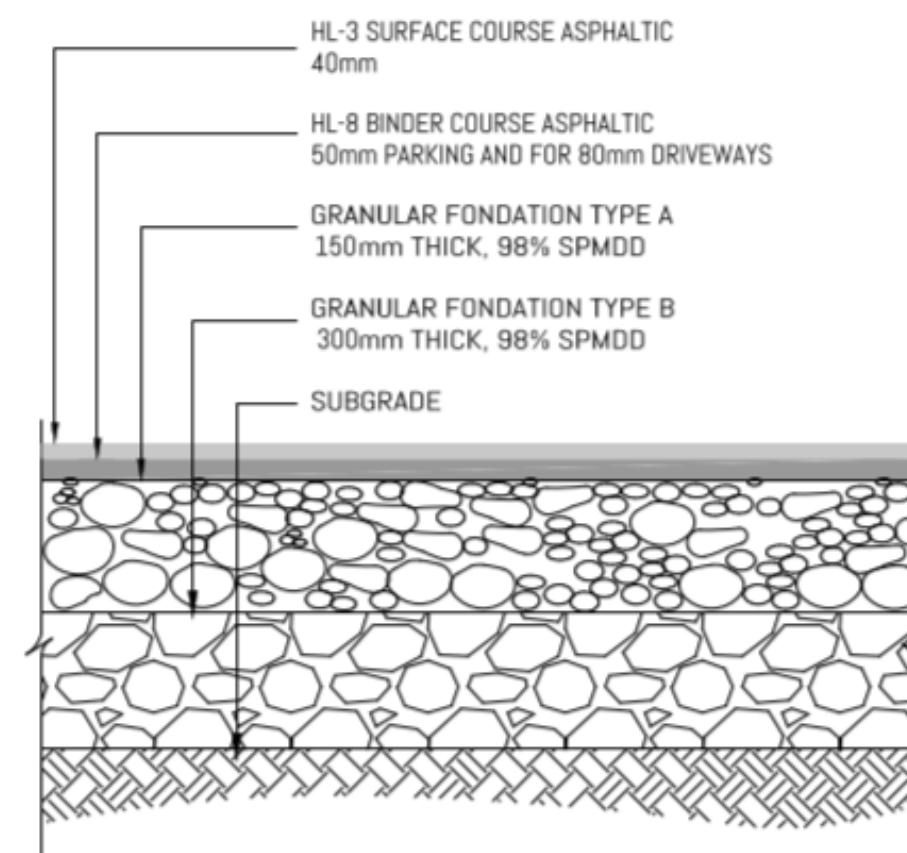

**PARKING AND ACCESS
FOUNDATION ASPHALT SURFACE**
(TO BE VERIFIED BY GEOTECHNICAL ENGINEER)

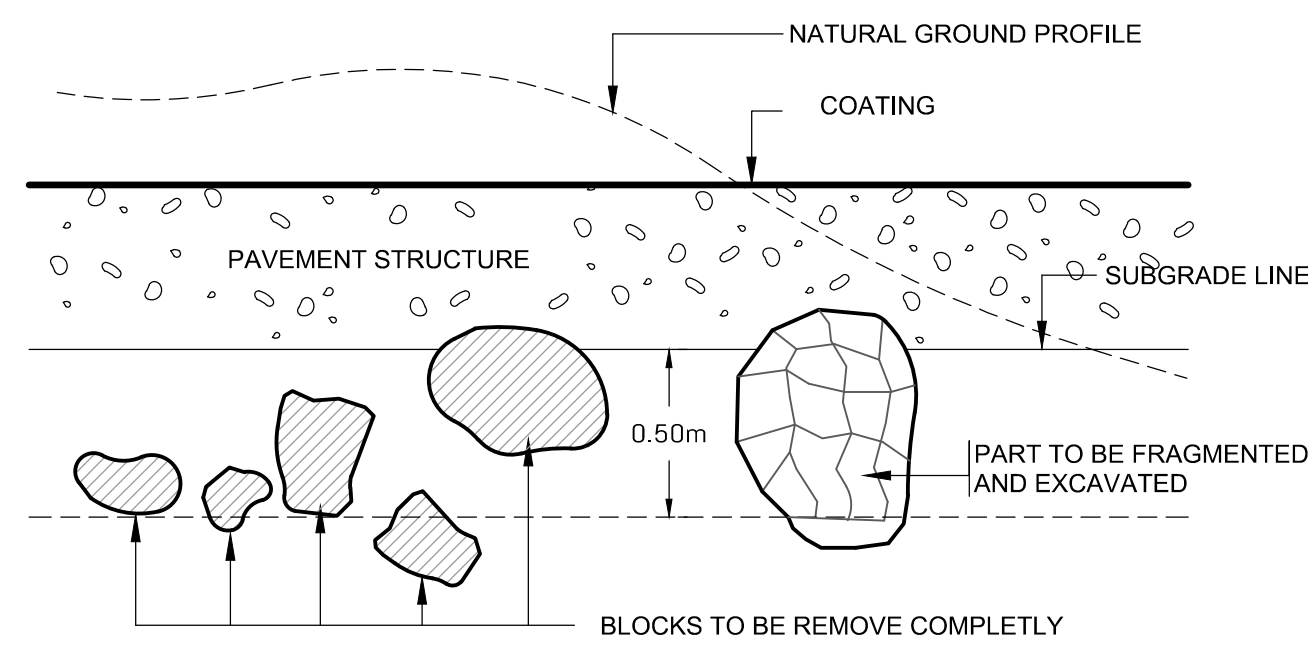

- NOTES:**
- ALL BLOCKS OVER 250mm DIAMETER PRESENT IN THE FIRST 500 mm UNDER INFRASTRUCTURE LINE MUST BE REMOVED, FRAGMENTED AND EXCAVATED TO 500 mm DEPT;
 - AFTER REMOVING BLOCS, THE EXCAVATIONS HAVE TO BE RAISED TO DESIGN SUBGRADE LEVELS WITH APPROVED COMPACTABLE ON SITE SOIL.
 - LIFTS OF 300mm THICK, COMPACTED AT 95% MSPDD
 - AS AN ALTERNATIVE TO SUBEXCAVATION, A WOVEN GEOTEXTILE SEPARATOR, SUCH AS TERRATRACK 24-15, AMOCO 2002, MIRAFI 500XL OR EQUIVALENT, MAY BE PLACED OVER SPONGY AREAS PRIOR TO PLACING THE GRANULAR 'B' SUB-BASE LAYER.

SUBGRADE PREPARATION DETAIL

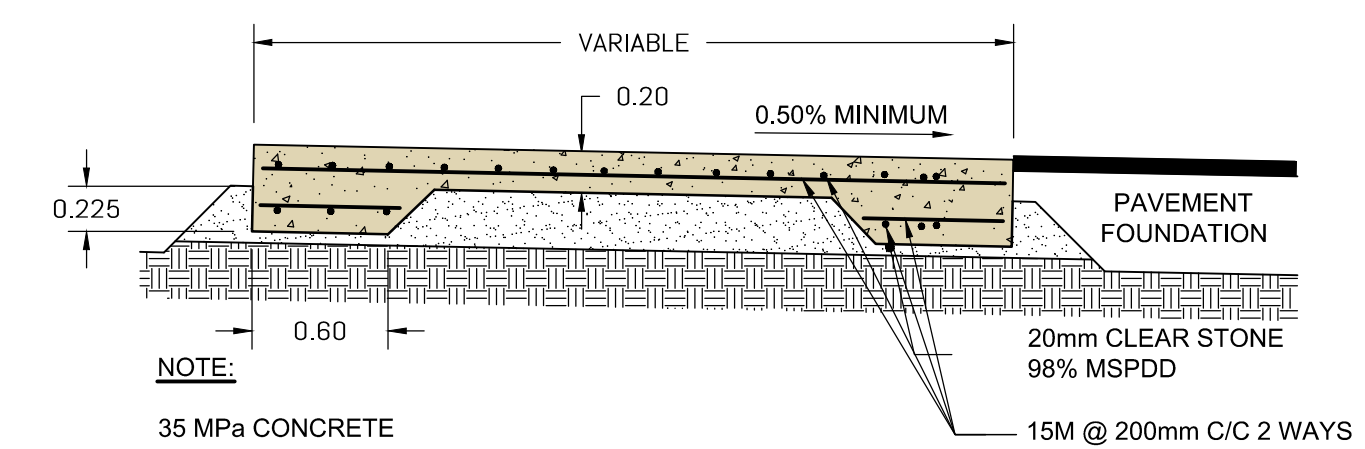

- NOTE:**
- 35 MPa CONCRETE
 - STATISTICAL STRENGTH TEST ANALYSIS TO CONFIRM THE STRENGTH LEVEL INCLUDING THE EXPECTED 7/28-DAY STRENGTH RATIO (AS PER CSA A23.1 CLAUSE 4.4.6.7)

REINFORCED CONCRETE SLAB FOR GARBAGE CONTAINERS

REV	DESCRIPTION	BY	DATE
F	FOR SITE PLAN APPLICATION REVISION 5	B.B	2022-07-12
E	FOR SITE PLAN APPLICATION REVISION 4	B.B	2022-07-07
D	FOR SITE PLAN APPLICATION REVISION 3	A.L.	2022-03-23

CLIENT: **emo batimo**
CONSTRUCTION PROMOTEUR ET GESTIONNAIRE IMMOBILIER

PROJECT: **LIB KANATA
KANATA AVENUE AND MARITIME WAY
CITY OF OTTAWA, ONTARIO**



733, chemin Jean-Adam, Piedmont (Québec) J0R 1R3
T. 450 227 1857
info@equipelaurence.ca | equipelaurence.ca



TITLE: **STANDARD SECTIONS AND DETAILS II**

SCALE: **NO SCALE**

F-LACROIX, CPI	C-206.dwg
DESIGN	DRAWING
J. QUESNEL, DESSINATEUR	2021-09-14
DRAWN	DATE
B. BRAY, ING	600401
APPROVED	PROJECT NO
	PLAN NO



FIRE FLOW DEMAND = 16,000L
 TOTAL FIRE FLOW CONTRIBUTION = 47,500L

150m FROM
 BUILDING FOOTPRINT

75m FROM
 BUILDING FOOTPRINT

BUILDING FOOTPRINT

- HYDRANTS ≤ 75m
- HYDRANTS > 75m & ≤ 150m
- HYDRANTS > 150m

REV	DESCRIPTION	BY	DATE
F	FOR SITE PLAN APPLICATION REVISION 5	B.B	2022-07-12
E	FOR SITE PLAN APPLICATION REVISION 4	B.B	2022-07-07
D	FOR SITE PLAN APPLICATION REVISION 3	A.L.	2022-03-23

CLIENT: **emo batimo**
 CONSTRUCTION PROMOTEUR ET GESTIONNAIRE IMMOBILIER

PROJECT:
 LIB KANATA
 KANATA AVENUE AND MARITIME WAY
 CITY OF OTTAWA, ONTARIO

LAURENCE
 ÉQUIPE
 INGÉNIERIE CIVILE
 733, chemin Jean-Adam, Piedmont (Québec) J0R 1R3
 T. 450 227 1857
 info@equipelaurence.ca | equipelaurence.ca



TITLE:
 FIRE HYDRANT COVERAGE MAP

SCALE: Horizontale 1:1000

F LACROIX, CPI	C-207.dwg
DESIGN	DRAWING
J. QUESNEL, DESSINATEUR	2021-09-14
DATE	
B. BRAY, ING	600401
APPROVED	PROJECT NO
	PLAN NO

APPENDIX B

Background Documents:

Land Survey by Annis, O'Sullivan, Vollebakk Ltd. on April 13, 2021

Excerpts from Stormwater Management Report for Kanata Town Centre by J.L. Richards & Associates Limited dated January 1999

MVCA Correspondence dated February 4th, 2022

MVCA Comment Letter dated December 22nd, 2021

PART OF LOTS 2 AND 3
CONCESSION 2
GEOGRAPHIC TOWNSHIP OF MARCH
CITY OF OTTAWA
Prepared by Annis, O'Sullivan, Vollebek Ltd.

Surveyor's Certificate
I CERTIFY THAT
1. This survey and plan are correct and in accordance with the Survey Act and the Surveyors Act and the regulations made under them.
2. The survey was completed on the 13th day of April, 2021.

Date: _____
T. Harbeck
Ontario Land Surveyor

Scale 1:250
0 5 10 Metres

Metric
DISTANCES SHOWN ON THIS PLAN ARE IN METRES AND CAN BE CONVERTED TO FEET BY DIVIDING BY 0.3048

Notes & Legend

Denotes	
—+—	Survey Monument Planted
—+—	Survey Monument Found
—+—	Standard Iron Bar
SSIB	Short Standard Iron Bar
IB	Iron Bar
RP	Rock Post
NT	Non-Tangential
(WT)	Witness
Mes.	Measured
(AOG)	Annis, O'Sullivan, Vollebek Ltd.
(P)	Plan 4R-9182
(P2)	Plan 4R-16146
(P3)	Plan 4R-31544
(P4)	Plan 4R-31544
(T)	Deciduous Tree
(C)	Coniferous Tree
(FH)	Fire Hydrant
(WV)	Water Valve
(M-S)	Maintenance Hole (Storm Sewer)
(M-S)	Maintenance Hole (Sanitary)
(M-T)	Maintenance Hole (Bell Telephone)
(M-T)	Maintenance Hole (Traffic)
(M-H)	Maintenance Hole (Hydro)
(T-C)	Cable Terminal Box
(VC)	Valve Chamber (Watermain)
(ST)	Underground Storm Sewer
(S)	Underground Sanitary Sewer
(CB)	Catch Basin
(S)	Sign
(UP)	Utility Pole
(AN)	Anchor
(LS)	Light Standard
(D)	Diameter
(E)	Location of Elevations
(E)	Top of Concrete Curb Elevation
(C/L)	Centreline
(P)	Property Line
(CP)	Concrete Pipe
(T/P)	Top of Pipe

Bearings hereon are grid bearings referred to the northerly limit of Kanata Avenue having a bearing of N84°02'15"E and are referenced to Specified Control Points 01919680037 and 01919791051, MTM Zone 9 (76°30' West Longitude) NAD-83 (original).

ELEVATION NOTES
1. Elevations shown are geodetic and are referred to the CGVD28 geodetic datum.
2. It is the responsibility of the user of this information to verify that the job benchmark has not been altered or disturbed and that its relative elevation and description agrees with the information shown on this drawing.

UTILITY NOTES
1. This drawing cannot be accepted as acknowledging all of the utilities and it will be the responsibility of the user to contact the respective utility authorities for confirmation.
2. Only visible surface utilities were located.
3. A field location of underground plant by the pertinent utility authority is mandatory before any work involving breaking ground, probing, excavating, etc.

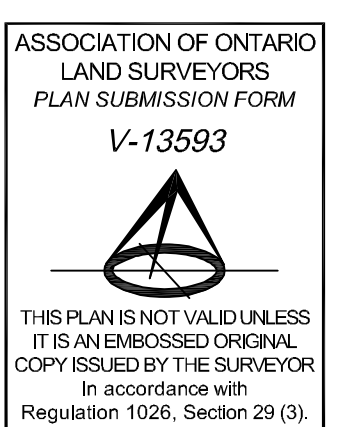

STORMWATER MANAGEMENT REPORT

**KANATA TOWN CENTRE
CENTRAL BUSINESS DISTRICT**

VOLUME 1 OF 2

January, 1999

Prepared for:

URBANDALE CORPORATION
2193 Arch Street
Ottawa, ON K1G 2H5

Prepared by:

J.L. RICHARDS & ASSOCIATES LIMITED
Consulting Engineers, Architects & Planners
864 Lady Ellen Place
Ottawa, ON K1Z 5M2

JLR 15712

4.0 PROPOSED STORMWATER MANAGEMENT FACILITY

4.1 General

Urbanization of the lands referred as the Kanata Town Centre - Central Business District will change the hydrological regime of Watts Creek. The potential impacts associated with urban runoff arise primarily from the amount of urban area that is impervious to rain and snowmelt water. These impervious urban surfaces increase the amount of surface runoff that is generated and is conveyed more efficiently to the receiving stream via a storm sewer system. Furthermore, direct runoff from urban areas is known to carry a range of potentially undesirable compounds such as high loadings of suspended solids, heavy metals, nutrient compounds etc. To mitigate these potential impacts, the 1993 Master Drainage Study, has formulated alternatives to address these concerns. The 1993 study concluded that two detention facilities (incorporating both quality and quantity controls) is the preferred option to meet the current water quality and quantity guidelines and, at the same time, protect Watts Creek's existing environmental features. In 1996-1997, the first SWMF was constructed to service Phase 1 residential lands. With the beginning of development of the Kanata Town Centre - Central Business District in 1998 and with additional development scheduled in 1999 (Hotel Site), the need for a storm sewer outlet was required. In general, the second SWMF was designed following the same overall concept outlined in the 1993 Master Drainage Study and to meet current water quality guidelines.

4.2 Stormwater Management Sizing

The water quality treatment of the proposed SWMF has been designed based on Table 4.1 of the MOEE Stormwater Manual entitled "Stormwater Management Practices Planning and Design Manual, page 173, (MOEE, June 1994)". This table recommends that for a wet pond with a protection level 2 (this type of protection includes feeding areas particularly for adult fish, areas of unspecialized spawning habitat and pool-riffle-run complexes that occur along much of a watercourse), a water quality storage volume of 130 m³/ha is required for a TSS removal of 70% of a tributary area having an average imperviousness of 70%. Furthermore, this table recommends that 40 m³/ha be used as extended detention storage and the remaining i.e. 90 m³/ha, be used as permanent pool volume. To determine the required volume for both the permanent pool and the extended detention storage, a table showing all tributary areas to the proposed stormwater management facility was developed (refer to

Appendix 'H' for table). This table shows that 61.24 ha of contributing area will be serviced by the future SWMF. The average total imperviousness for these contributing areas was found to be 74%. Based on the information presented in this table (refer to Appendix 'H'), the MOEE design manual therefore recommends that a permanent pool volume of 5512 m³ and an extended storage volume of 2450 m³ be provided to achieve the required treatment for a protection level 2 (i.e. TSS removal of 70%).

4.2.1 SWMF Design Rationale

The length to width ratio for the proposed SWMF is approximately 5 to 1 which exceeds the 3 to 1 length to width ratio recommended in the "Stormwater Management Practices Planning and Design Manual, page 76, (MOEE, June 1994)". This manual also recommends that a minimum of 24 hour drawdown time be used to minimize the possibility of short-circuiting and hence maximizing the performance of the facility. To minimize the risk of short-circuiting and maximize the TSS removal, the outlet structure of the SWMF was designed using a 48 hour drawdown time (refer to Section 4.3 for additional information). Using this outlet configuration (i.e. 48 hour drawdown time), the maximum outflow rate at elevation 90.20 m (i.e. maximum elevation of the extended detention storage) is 0.028 m³/s. With this type of restricted outflow rate and with storm inflow to the SWMF of approximately 2.83 m³/s (total flow to facility generated by a 4 hour - 25 mm Chicago design storm event), it is expected that this configuration will eliminate any possibility of short-circuiting.

The length to width ratio for the sedimentation forebay is approximately 3 to 1 which exceeds the 2 to 1 ratio recommended in the "Stormwater Management Practices Planning and Design Manual, page 89, (MOEE, June 1994)".

De: Erica Ogden <eogden@mvc.on.ca>
Envoyé: 4 février 2022 16:22
À: Lauren Menard
Cc: Benoit Bray; Olivier Morrissey
Objet: RE: Kanata Avenue - Quality Control Requirements
Pièces jointes: [150 Kanata Ave - MVCA Comment Letter - Dec 22 2021.pdf](#)

Indicateur de suivi: Assurer un suivi
État de l'indicateur: Avec indicateur

Hello Lauren,

Thank you for your e-mail. I apologize when we spoke on the phone, I hadn't realized that you were looking to discuss an application which MVCA has already reviewed a submission and provided comments on.

In case you haven't yet received them from the City, I have attached a copy of our comments from December 22, 2021.

The water quality target for this site is an enhanced level of treatment, 80% TSS removal. It is noted that the Kanata Town Centre- Stormwater Management Facility, to which the runoff from the site drains, was designed to provide only 70% TSS removal. Please explore whether BMPs/LIDs could be implemented on site to provide additional water quality treatment.

The Carp River Watershed Subwatershed Study identifies the subject site as a low groundwater recharge area, which has an annual infiltration target of 73mm/year.

If you have any other questions, I would be happy to set up a time to discuss with you.

Thank you,

Erica C. Ogden, MCIP, RPP | Environmental Planner | Mississippi Valley Conservation Authority
10970 Highway 7, Carleton Place, ON K7C 3P1
www.mvc.on.ca | c. 613 451 0463 | o. 613 253 0006 ext. 229 | eogden@mvc.on.ca

From: Lauren Menard <lménard@equipelaurence.ca>
Sent: February 2, 2022 3:05 PM
To: Erica Ogden <eogden@mvc.on.ca>
Cc: Benoit Bray <bbray@equipelaurence.ca>; Olivier Morrissey <omorrissey@equipelaurence.ca>
Subject: Kanata Avenue - Quality Control Requirements

Hi Erica,

As mentioned over the phone, we are a Civil Engineering firm based out of Quebec currently working on a project located at the intersection of Kanata Avenue and Maritime Way. See site location below.

The site is roughly 1.6 ha.

In terms of stormwater management, what would be the quality control requirements as well as the infiltration targets for this site?

Please let me know if you require any additional information.



Regards,



LAUREN MENARD CPI

20845, ch. de la Côte-Nord, bureau 204, Boisbriand (Qc) J7E 4H5
T 450 970-3100 p.271 | C 514 503-3495

lménard@equipelaurence.ca | equipelaurence.ca

[Piedmont](#) | [Boisbriand](#) | [Joliette](#) | [Montréal](#) | [Mont-Laurier](#) | [Gatineau](#)

Rejoins notre équipe de professionnels passionnés!
➔ **ENVOIE TON CV**

Conservation Partners Partenaires de conservation



File: PMRSP-31 & PMRZA-38

December 22, 2021

Lisa Stern
Development Review Planner
Planning, Infrastructure and Economic Development
City of Ottawa
110 Laurier Avenue West, 4th Floor
Ottawa, ON K1P 1J1

Dear Ms. Stern:

**Re: Application for Site Plan Control and Zoning By-law Amendment – D07-12-21-0153 & D02-02-21-0109
150 Kanata Avenue, City of Ottawa (March)**

The staff of Mississippi Valley Conservation Authority (MVCA) has reviewed the above noted application for concerns related to natural heritage and natural hazards for the subject property and surrounding lands. The scope of the natural heritage review includes wetlands, watercourses and significant valleylands, while the focus of the natural hazards review includes flood plain, unstable slopes and unstable soils.

The following comments are offered for your consideration:

Summary of Proposal

A Zoning By-law Amendment and Site Plan Control applications have been submitted for the development of a mixed use building with seven, nine and 11-storey components that wraps around the corner of Kanata Avenue and Maritime Way. The building is comprised of approximately 351 residential units and 820 m² of commercial and office space. Access is proposed to be taken from Maritime Way. A total of 445 parking spaces are proposed both at grade and underground. The applicant is seeking relief from the requirements of the Zoning Bylaw as follows:

- Increase the maximum required rear yard setback; and
- Reduce required non-residential space provided.

Property Overview

The subject site is located on the north side of Kanata Avenue west of Maritime Way, south of Bill Teron Park and north of the shopping centre. The subject site makes up a portion of a larger piece of land owned by the City which consists of public parkland and lands intended for future development. The site is currently vacant and densely vegetated. The subject site is zoned MC2 H28 (Mixed-Use Centre Zone, subzone 2) and MC5 H35 (Mixed-Use Centre Zone, subzone 5) pursuant to Zoning By-law 2008-250.

Natural Heritage

MVCA staff have been circulated the following in support of the development:

- “Bill Teron Park Expansion and Future Development Lands, Environmental Impact Statement and Tree Conservation Report” by Stantec, February 21, 2020.
- “Landscape Details, Kanata Town Centre (Parcels 2 & 3) Kanata Ave/Maritime Way” by Lames B. Lennox and Associates Inc., September 27, 2021.
- “Site Plan, Kanata Town Centre (Parcels 2 & 3) Kanata Ave/Maritime Way” by Emd Batimo, September 22, 2021.

MVCA concurs with the methods and recommended mitigation measures within the EIS, however the EIS submitted was not site specific and did not discuss the site-specific impacts of the proposed development at 150 Kanata Ave. MVCA identifies no natural heritage features within the scope of our review, associated with the subject lands.

Natural Hazards

Available soils mapping indicates there is a potential for organic soils to be associated with the subject lands. Organic soils can be a concern as they lack structure and compress so much they usually cannot support structures. MVCA notes that a Geotechnical Investigation has been completed for the proposed development which notes that topsoil and deleterious fill containing organic material should be stripped from under any buildings, paved areas and other settlement sensitive structures. MVCA identifies no other natural hazards within the scope of our review, associated with the subject lands.

Stormwater Management

MVCA staff has reviewed the following reports, with a focus on the stormwater quantity and quality management:

- Stormwater Management Report Lib Kanata, Ottawa, by Equipe Laurence Inc., September, 2021.
- Geotechnical Investigation – Proposed Mixed-Use Development, Parcels 2 and 3 of 6301 Campeau Drive, by Pinchin, July 22, 2021

The predevelopment overland flow was calculated to be 109.2 L/s and 234.0 L/s for the 5-yr and 100-yr storm, respectively. Post development flows will be restricted to the 5-yr storm up to and including the 100-yr storm plus 20%. The runoff coefficients for the 100-yr storm were increased by 25%. Excess water will be stored on the roof and in an underground storage tank.

MVCA offers the following comments for your consideration:

- i) Please include the specifications, details and location of the underground storage tank.
 - ii) Please include roof drain specifications, details and locations.
 - iii) Please include all ponding depths for the 100-yr storm.
 - iv) The Pinchin Geotechnical Investigation identified sand in the northern and western quadrants of the site. Please consider low impact development techniques as part of the design.
- i) Section 5.0 Stormwater Quality notes that “*controlled flows from the site are tributary to the Kanata Town Centre Stormwater Management Facility, which is anticipated to provide the quality control for the site runoff*”. Please include excerpts from the governing reports demonstrating the required capacity and water quality treatment for the site.
 - ii) Section 6.0 Erosion and Sediment Control notes that filter cloth will be installed over all existing

manholes. Please use catch basin inserts or a demonstrated equivalent. The Erosion and Sediment Control Plan should indicate the location of all catch basin inserts at all catch basins, catch basin manholes, and storm manholes.

- iii) Please include the installation of a mud mat under Section 6.0 Erosion and Sediment Control and include the location and detail in the erosion and sediment control plan.
- iv) Please include information on dewatering under Section 6.0 Erosion and Sediment Control such as the use of filter socks and/or dewatering traps.

Conclusion

MVCA does not object to Zoning By-law Amendment application D02-02-21-0109, as currently proposed.

MVCA recommends that the above noted stormwater management comments be addressed prior to proceeding with the Site Plan Control application D07-12-21-0153.

Thank you for the opportunity to review and comment. Please advise us of the decision in this matter.

Please contact the undersigned with any questions that may arise.

Regards,

A handwritten signature in dark ink that reads "Erica C Ogden". The signature is written in a cursive, flowing style.

Erica C. Ogden, MCIP, RPP
Environmental Planner

APPENDIX C

Stormwater Flows and Storage Requirements

Detailed Calculations

PRE-DEVELOPMENT FLOW

Parameters	Values	Units
Forested area	15990	m ²
5-year runoff coefficient	0,200	-
100-year runoff coefficient	0,250	-
Time of concentration	10	min
Pre-development 5-year flow	111,1	ℓ/s
Pre-development 100-year flow	237,9	ℓ/s

* The 100-year runoff coefficients are determined by increasing the 5-year runoff coefficients by 25% as per the city of Ottawa sewer design guidelines.

PROPOSED UNCONTROLLED FLOW

Parameters	Values	Units
Impervious surfaces	1346	m ²
Grass surfaces	1046	m ²
Forested surfaces	0	m ²
Total area	2392	m ²
5-year Runoff coefficient	0,616	-
100-year Runoff coefficient	0,770	-
Time of concentration	10	min
Uncontrolled 5-year flow	51,2	ℓ/s
Uncontrolled 100-year flow	95,6	ℓ/s

* The 100-year runoff coefficients are determined by increasing the 5-year runoff coefficients by 25% as per the city of Ottawa sewer design guidelines.

PROPOSED CATCHMENT AREAS

Drainage area	Total area (m ²)	Impervious surfaces		Grass surfaces		Forested area		5-year runoff coefficient	100-year runoff coefficient
		Area (m ²)	Runoff coefficient	Area (m ²)	Runoff coefficient	Area (m ²)	Runoff coefficient		
CB-01	1187	520	0,900	0	0,250	667	0,200	0,507	0,557
CB-02	1408	693	0,900	0	0,250	715	0,200	0,545	0,595
CB-03	521	521	0,900	0	0,250	0	0,200	0,900	0,950
CB-04	1424	825	0,900	0	0,250	599	0,200	0,606	0,682
CB-05	526	526	0,900	0	0,250	0	0,200	0,900	0,950
CB-06	714	714	0,900	0	0,250	0	0,200	0,900	0,950
CB-07	558	558	0,900	0	0,250	0	0,200	0,900	0,950
CB-08	682	682	0,900	0	0,250	0	0,200	0,900	0,950
CB-09	422	368	0,950	54	0,250	0	0,200	0,900	0,950
CB-10	556	449	0,950	107	0,250	0	0,200	0,900	0,950
Building	5600	5600	0,900	0	0,250	0	0,200	0,900	0,950
Total	13598	11456	-	161	-	1981	Weighted Cr	0,79	0,84

* The 100-year runoff coefficients are determined by increasing the 5-year runoff coefficients by 25% as per the city of Ottawa sewer design guidelines.

PROPOSED CONTROLLED FLOW

Parameters	Values	Units
5-year pre-development flow	111,1	ℓ/s
100-year uncontrolled flow	95,6	ℓ/s
Allowable release rate / Controlled flow	15,5	ℓ/s
5-year storage requirements	403,9	m ³
100-year storage requirements	845,3	m ³

**5-YEAR EVENT STORAGE REQUIREMENTS - CITY OF OTTAWA IDF CURVES
CONTROLLED FLOW OF 15.5 L/S**

Time of concentration (min)	Intensity (mm/hr)	Peak Flow (m ³ /s)	Max volume (m ³)	Outgoing volume (m ³)	Required storage volume (m ³)
5,00	169,41	0,51	152,15	4,19	147,96
10,00	125,03	0,37	224,57	8,37	216,20
15,00	100,27	0,30	270,14	12,56	257,58
20,00	84,30	0,25	302,83	16,75	286,09
25,00	73,08	0,22	328,13	20,93	307,20
30,00	64,71	0,19	348,70	25,12	323,58
35,00	58,22	0,17	366,00	29,31	336,70
40,00	53,02	0,16	380,93	33,49	347,44
45,00	48,75	0,15	394,06	37,68	356,38
50,00	45,18	0,14	405,78	41,87	363,91
55,00	42,15	0,13	416,37	46,05	370,31
60,00	39,53	0,12	426,03	50,24	375,79
65,00	37,25	0,11	434,92	54,43	380,49
70,00	35,25	0,11	443,15	58,61	384,54
75,00	33,47	0,10	450,82	62,80	388,02
80,00	31,87	0,10	458,01	66,99	391,02
85,00	30,44	0,09	464,77	71,17	393,59
90,00	29,15	0,09	471,15	75,36	395,79
95,00	27,97	0,08	477,20	79,55	397,65
100,00	26,89	0,08	482,95	83,73	399,22
105,00	25,90	0,08	488,44	87,92	400,52
110,00	24,99	0,07	493,68	92,11	401,57
115,00	24,14	0,07	498,70	96,30	402,40
120,00	23,36	0,07	503,51	100,48	403,03
125,00	22,63	0,07	508,15	104,67	403,48
130,00	21,95	0,07	512,61	108,86	403,75
135,00	21,32	0,06	516,91	113,04	403,87
140,00	20,72	0,06	521,07	117,23	403,84

*The rain intensity are increased by 20% as per the city of Ottawa sewer design guidelines to account for climate change effects

*The IDF curves were taken from the city of Ottawa sewer design guidelines.

100-YEAR EVENT STORAGE REQUIREMENTS - CITY OF OTTAWA IDF CURVES CONTROLLED FLOW OF 15.5 L/S

Time of concentration (min)	Intensity (mm/hr)	Peak Flow (m ³ /s)	Max volume (m ³)	Outgoing volume (m ³)	Required storage volume (m ³)
5,00	291,24	0,93	278,29	4,19	274,10
10,00	214,27	0,68	409,48	8,37	401,11
15,00	171,47	0,55	491,54	12,56	478,98
20,00	143,94	0,46	550,15	16,75	533,40
40,00	90,17	0,29	689,30	33,49	655,81
60,00	67,07	0,21	769,08	50,24	718,84
80,00	53,99	0,17	825,40	66,99	758,41
100,00	45,48	0,14	869,21	83,73	785,47
120,00	39,47	0,13	905,23	100,48	804,75
140,00	34,98	0,11	935,94	117,23	818,71
160,00	31,49	0,10	962,77	133,98	828,79
180,00	28,68	0,09	986,66	150,72	835,93
200,00	26,38	0,08	1008,22	167,47	840,75
220,00	24,45	0,08	1027,90	184,22	843,69
240,00	22,81	0,07	1046,03	200,96	845,07
245,00	22,43	0,07	1050,35	205,15	845,20
250,00	22,07	0,07	1054,59	209,34	845,26
255,00	21,73	0,07	1058,76	213,52	845,23

*The rain intensity is increased by 20% as per the city of Ottawa sewer design guidelines to account for climate change

*The IDF curves were taken from the city of Ottawa sewer design guidelines.

PROPOSED STORMWATER STORAGE

Description	Parameters	Values	Units
Proposed storage volume on roof, underground concrete tank and sewer structures	5-year required storage ¹	404	m ³
	100-year required storage ¹	845	m ³
	Maximum accumulation on roof (to be verified by mechanical engineer)	150	mm
	Volume retained on roof	261,0	m ³
	Volume retained in underground concrete tank	600,0	m ³
	Volume retained in sewer structures and pipes	10,0	m ³
	Total storage volume available	871	m³

1 - The rain intensity is increased by 20% as per the city of Ottawa sewer design guidelines to account for climate change.

APPENDIX D

Sanitary Sewer Design Flows

Detailed Calculations



SANITARY SEWER DESIGN FLOWS

Reference : Ottawa Sewer Design Guidelines, *Infrastructure Services Department*, October 2012

A. Population Density

(Article 4.3, Table 4.2)	Number of units	Persons Per Unit	Population Density
1-bedroom	222	1,4	310,8
2-bedroom	152	2,1	319,2
3-bedroom	24	3,1	74,4
		Total population density:	704

B. Average Wastewater Flows

(Article 4.4.1, Figure 4.3)

Average wastewater flow per capita for residential use:	280 L/c/d
Average wastewater flow for residential use:	197 232 L/d
Average wastewater flow for commercial use:	28 000 L/gross ha/d
Commercial Areas: 1214 m ²	3 399 L/d

C. Peaking Factors

(Article 4.4.1, Figure 4.3)

Residential peak factor: Harmon Equation
 K=1

$$P.F. = 1 + \left(\frac{14}{4 + \left(\frac{P}{1000} \right)^{1/2}} \right) \times K$$

Residential peak factor: 3,89
 Commercial peak factor: 1,50

D. Extraneous Flows

(Article 4.4.1.4)

Infiltration allowance:	0,28	L/s/effective gross ha	for 1.599 ha
Infiltration flow:	0,45	L/s	

F. Total Wastewater Design Flow

$$Q_{\text{design}} = [(3.89 \times 197\,232 \text{ L/d}) + (1.50 \times 3\,399 \text{ L/d})] \times 1/86\,400 \text{ sec/d} + 0.45 \text{ L/s}$$

$$Q_{\text{design}} = 9,39 \text{ L/s}$$

SANITARY SEWER CALCULATION SHEET



Manning's n = 0,013

LOCATION			RESIDENTIAL AREA AND POPULATION					COMM			INDUST			INST		C+I	INFILTRATION				PIPE						
STREET	FROM M.H.	TO M.H.	AREA (ha)	POP.	CUMULATIVE		PEAK FACT.	PEAK FLOW (l/s)	AREA (ha)	ACCU. AREA (ha)	AREA (ha)	ACCU. AREA (ha)	PEAK FACTOR (per MOE)	AREA (ha)	ACCU. AREA (ha)	PEAK FLOW (l/s)	TOTAL AREA (ha)	ACCU. AREA (ha)	INFILT. FLOW (l/s)	TOTAL FLOW (l/s)	LENGTH (m)	DIA. (mm)	SLOPE (%)	CAP. (FULL) (l/s)	VEL. (FULL) (m/s)		
					AREA (ha)	POP.																					
Maritime Way	BUILD.	SAN-MH-05						9,39			-	-	-	-	-		1,599	1,599	0,45	9,84	1,00	250	1,00	59,47	1,21		
Maritime Way	SAN-MH-05	SAN-MH-04						9,39			-	-	-	-	-		-	-	-	9,84	53,20	250	1,00	59,47	1,21		
Maritime Way	BUILD.	SAN-MH-04						9,39			-	-	-	-	-		-	-	-	9,84	53,20	250	1,00	59,47	1,21		
Maritime Way	SAN-MH-04	SAN-MH-03						9,39			-	-	-	-	-		-	-	-	9,84	40,80	250	1,00	59,47	1,21		
Maritime Way	SAN-MH-03	SAN-MH-02						9,39			-	-	-	-	-		-	-	-	9,84	45,00	250	1,00	59,47	1,21		
Maritime Way	SAN-MH-02	SAN-MH-01						9,39			-	-	-	-	-		-	-	-	9,84	57,70	250	1,00	59,47	1,21		
Maritime Way	SAN-MH-01	E-SAN-MH-05						9,39			-	-	-	-	-		-	-	-	9,84	20,10	250	2,00	84,10	1,71		
DESIGN PARAMETERS																Designed:		PROJECT: LIB KANATA									
Average Daily Flow = 280 l/p/day Comm/Inst Flow = 28000 L/ha/da Industrial Flow = 28000 L/ha/da Max Res. Peak Factor = 3,93 Commercial / Inst Peak Factor = 1,50																		LOCATION: KANATA AVENUE AND MARITIME WAY, OTTAWA, ON									
Industrial Peak Factor = as per MOE Graph Extraneous Flow = 0,28 L/s/ha Minimum Velocity = 0,76 m/s Manning's n = 0,013																Checked:		Dwg. Reference: C-204				File Ref.: 600401		Date: 2022-07-12		Sheet No. 1 of 1	

APPENDIX E

Domestic Water Demand

Detailed Calculations



DOMESTIC WATER DEMAND CALCULATION

Reference : Ottawa Design Guidelines - Water Distribution, *Infrastructure Services department*, July 2010

A. Population Density

<i>(Article 4.2.8, Table 4.1)</i>	Number of rooms	Persons Per Unit	Population Density
1-bedroom	222	1,4	310,8
2-bedroom	152	2,1	319,2
3-bedroom	24	3,1	74,4
		Total population density:	704

B. Average Day Demand

(Article 4.2.8, Table 4.2)

Average day demand per capita for residential use:		280 L/c/d	
Average day demand for residential use:		197 232 L/d	
Average day demand for other commercial use:		28 000 L/gross ha/d	
Commercial Areas:	1214 m ²	3 399 L/d	
Total average day demand:		200 631 L/d	= 2,32 L/s

C. Maximum Daily Demand

(Article 4.2.8, Table 4.2)

$$\begin{aligned}
 \text{Maximum daily demand} &= 2.5 \times 196\,252 \text{ L/d} + 1.5 \times 3\,399 \text{ L/d} \\
 &= 490\,630 \text{ L/d} + 5\,099 \text{ L/d} \\
 &= 498\,179 \text{ L/d} \\
 &= 5,77 \text{ L/s}
 \end{aligned}$$

D. Maximum Hour Demand

(Article 4.2.8, Table 4.2 and Technical Bulletin ISD-2010-2)

$$\begin{aligned}
 \text{Maximum hour demand} &= 2.2 \times (\text{Max Day}_{\text{res}}) \text{ L/d} + 1.8 \times (\text{Max Day}_{\text{com}}) \text{ L/d} \\
 \text{Maximum hour demand} &= 2.2 \times 490\,630 \text{ L/d} + 1.8 \times 5\,099 \text{ L/d} \\
 &= 1\,093\,954 \text{ L/d} \\
 &= 12,66 \text{ L/s}
 \end{aligned}$$

F. Results

Population density =	704	people
Average day demand =	2,32	L/s
Maximum daily demand =	5,77	L/s
Maximum hour demand =	12,66	L/s

APPENDIX F

Required Fire Demand
Detailed Calculations



REQUIRED FIRE DEMAND CALCULATION

References : Ottawa Technical Bulletin ISTB-2018-02, March 2018
 Water Supply for Public Fire Protection, *Fire Underwriters Survey*, 1999

A. Type of construction

Non-combustible construction : $C = 0,8$

B. Total Floor Area

	Surface Area Per Floor	Number of Floors	Floor Area
Ground Floor	5 106 m ²	1	5 106 m ²
Levels 2-3	4 386 m ²	2	8 772 m ²
Levels 4-7	3 958 m ²	4	15 832 m ²
Levels 8-9	3 442 m ²	2	6 884 m ²
Level 10-11	1 377 m ²	2	2 754 m ²
			$A = 39\,348\text{ m}^2$

D. Base Fire Flow

$$F = 220 \times C\sqrt{A} = 34\,912 \text{ L/min}$$

The base fire flow must be rounded up to the nearest 1,000 L/min, hence : $F = 35\,000 \text{ L/min}$

E. Fire Flow Adjustments

E.1 Building occupancy (adjustments to the value obtained in D)

Occupancy : Limited Combustible -15% $F = 29\,750 \text{ L/min}$ ①

E.2 Automatic sprinkler system (adjustments to the value obtained in E.1)

NPFA 13 Designed system:	Yes	-30%
Standard water supply:	Yes	-10%
Fully supervised system:	Yes	-10%

E.3 Exposure surcharge (adjustments to the value obtained in E.1)

Lenght-Height Factors (no impact on exposure surcharge calculations since distances > 30m)

North side	N/A	
East side	L (48.92m) * H (7 storeys) =	342.44
South side	N/A	
West side	L (46.99m) * H (6 storeys) =	281.94



North side	>45m	0%
East side	32.4m (30.1 to 45m)	5%
South side	>45m	0%
West side	33.1m (30.1 to 45m)	5%

Reductions from E.2 = -50% = -14 875 L/min (2)

Increases from E.3 = 10% = 2 975 L/min (3)

(1) + (2) + (3) $F = 17\ 850$ L/min

The fire flow must be rounded up to the nearest 1,000 L/min, hence : $F = 18\ 000$ L/min

F. volume of Water Required During the Fire

The duration of water supply for a fire is: 2 hours

Required Volume = 2 160 000 L = 2 160 m³

Fire Demand = 18 000 L/min Required Volume = 2 160 m³