



## TABLE OF CONTENTS

1.0	PROJECT DESCRIPTION .....	1
1.1	Purpose .....	1
1.2	Site Description.....	1
1.3	Existing Conditions and Infrastructure.....	1
1.4	Proposed Development and Statistics .....	1
2.0	BACKGROUND STUDIES.....	2
2.1	Background Reports / Reference Information.....	2
2.2	Applicable Guidelines and Standards.....	2
3.0	PRE-CONSULTATION SUMMARY .....	3
4.0	WATERMAIN .....	4
4.1	Existing Watermain .....	4
4.2	Proposed Watermain.....	4
5.0	SANITARY DESIGN .....	6
5.1	Existing Sanitary Sewer .....	6
5.2	Proposed Sanitary Sewer .....	6
6.0	PROPOSED STORM WATER MANAGEMENT .....	7
6.1	Design Criteria and Methodology.....	7
6.2	Runoff Calculations.....	7
6.3	Pre-Development Drainage.....	8
6.4	Post-Development Drainage .....	8
6.5	Quantity Control .....	9
6.6	Quality Control .....	10
7.0	EROSION AND SEDIMENT CONTROL.....	11
7.1	Temporary Measures.....	11
7.2	Permanent Measures.....	11
8.0	SUMMARY.....	12
9.0	RECOMMENDATION.....	13
10.0	STATEMENT OF LIMITATIONS.....	14

## LIST OF TABLES

Table 1: Water Demands.....	4
Table 2: Boundary Conditions Results .....	5
Table 3: Fire Protection Confirmation.....	5
Table 4: Pre-Development Runoff Summary.....	8
Table 5: Post-Development Runoff Summary .....	8
Table 6: Post-Development Restricted Runoff Summary.....	9
Table 7: Storage Summary.....	10

## APPENDICES

Appendix A: Site Location Plan

Appendix B: City of Ottawa Pre-Consultation Notes

Appendix C: Watermain Calculations

Appendix D: Sanitary Calculations

Appendix E: Pre-Development Drainage Plan

Appendix F: Post-Development Drainage Plan

Appendix G: Stormwater Management Calculations

## 1.0 PROJECT DESCRIPTION

### 1.1 Purpose

McIntosh Perry (MP) has been retained by Jim Bell Architectural Design Inc. to prepare this Servicing and Stormwater Management Report in support of the Site Plan Control process for the proposed office building, located at 1037 Carp Road within the City of Ottawa (City File No. D07-12-21-0168).

The main purpose of this report is to present a servicing design for the development in accordance with the recommendations and guidelines provided by the City of Ottawa (City), the Mississippi Valley Conservation Authority (MVCA), and the Ministry of the Environment, Conservation and Parks (MECP). This report will address the water, sanitary and storm sewer servicing for the development, ensuring that existing and available services will adequately service the proposed development.

This report should be read in conjunction with the following drawing:

- CP-19-0125, C101 – Site Grading, Drainage Plan, and Servicing Plan

### 1.2 Site Description

The property is located at 1037 Carp Road. It is described as Plan 5R-4714, Part of Lot 23, Concession 12, Geographic Township of Goulbourn, City of Ottawa. The land in question covers approximately 0.27 ha and is located between Rothbourne Rd and Echowoods Ave. The development area for the proposed works is approximately 0.27 ha.

See Site Location Plan in Appendix 'A' for more details.

### 1.3 Existing Conditions and Infrastructure

The existing site is currently undeveloped and is made up of a gravel lane, trees and bushes. There are no sanitary, water or storm services currently on site. Storm water currently sheet flows to the east corner of the site where it is collected by a rear yard swale system which flows to an existing catchbasin.

Sewer and watermain mapping collected, along with the topographic survey completed by Fairhall Moffatt & Woodland Ltd. on December 18<sup>th</sup>, 2018, indicates that the following services exist across the property frontages within the adjacent municipal right-of-way:

- 200 mm diameter ductile iron watermain; and
- 150 mm diameter private polyethylene sanitary forcemain.

### 1.4 Proposed Development and Statistics

The proposal is to develop a 2-storey office building. The building will contain 14 office units with a building area of 513.84 m<sup>2</sup>.

## 2.0 BACKGROUND STUDIES

### 2.1 Background Reports/ Reference Information

As-built drawings of existing services, provided by the City of Ottawa Information centre, within the vicinity of the site were reviewed to identify infrastructure available to service the contemplated development. A topographic survey was completed by Fairhall Moffatt & Woodland Ltd. on December 18<sup>th</sup>, 2018, and revised September 12<sup>th</sup>, 2022.

### 2.2 Applicable Guidelines and Standards

City of Ottawa:

- ◆ Ottawa Sewer Design Guidelines, City of Ottawa, SDG002, October 2012. (Ottawa Sewer Guidelines)
  - Technical Bulletin ISTB-2014-01 City of Ottawa, February 2014. (ISTB-2014-01)
  - Technical Bulletin ISTB-2018-01 City of Ottawa, January 2018. (ISTB-2018-01)
  - Technical Bulletin ISTB-2018-03 City of Ottawa, March 2018. (ISTB-2018-03)
  - Technical Bulletin ISTB-2019-01 City of Ottawa, January 2019. (ISTB-2019-01)
  - Technical Bulletin ISTB-2019-02 City of Ottawa, February 2019. (ISTB-2019-02)
- ◆ Ottawa Design Guidelines – Water Distribution City of Ottawa, July 2010. (Ottawa Water Guidelines)
  - Technical Bulletin ISD-2010-2 City of Ottawa, December 15, 2010. (ISD-2010-2)
  - Technical Bulletin ISDTB-2014-02 City of Ottawa, May 2014. (ISDTB-2014-02)
  - Technical Bulletin ISTB-2018-02 City of Ottawa, March 2018. (ISTB-2018-02)

Ministry of Environment, Conservation and Parks:

- ◆ Stormwater Planning and Design Manual, Ministry of the Environment, March 2003. (MECP Stormwater Design Manual)
- ◆ Design Guidelines for Sewage Works, Ministry of the Environment, 2008. (MECP Sewer Design Guidelines)

### 3.0 PRE-CONSULTATION SUMMARY

A pre-consultation meeting was conducted on November 18<sup>th</sup>, 2019, regarding the proposed site. Specific design parameters to be incorporated within this design include the following:

- Control 5 through 100-year post-development flows to the 5 through 100-year pre-development flows with a combined C value of lesser of the existing or 0.5.

Pre-consultation notes can be found in Appendix 'B'.

## 4.0 WATERMAIN

### 4.1 Existing Watermain

There is an existing 200 mm diameter ductile iron watermain within Carp Road. The watermain services the adjacent property as well as the fire hydrants along Carp Road. There also is an existing public hydrant in the right of way of the neighbouring property to the north.

### 4.2 Proposed Watermain

A new 150 mm diameter PVC watermain is proposed to service the site complete with a water valve located at the property line and will be connected to the existing 200 mm diameter watermain within Carp Road. The watermain is designed to have a minimum of 2.4 m cover.

The Fire Underwriters Survey 1999 (FUS) method was utilized to determine the required fire flow for the site. The 'C' factor (type of construction) for the FUS calculation was determined to be 1.0 (ordinary type construction). The total floor area ('A' value) for the FUS calculation was determined to be 995.9 m<sup>2</sup>. The results of the calculations yielded a required fire flow of 6,000 L/min. A fire flow of 2700 L/min was calculated using the Ontario Building Code (OBC) requirements. The detailed calculations for the FUS and OBC can be found in Appendix 'C'.

The water demands for the proposed building have been calculated to adhere to the Ottawa Design Guidelines – Water Distribution manual and can be found in Appendix 'C'. The results have been summarized below:

Table 1: Water Demands

Ste Area	0.27 ha
Office	75 L/(7m <sup>2</sup> /d)
Average Day Demand (L/s)	0.06
Maximum Daily Demand (L/s)	0.10
Peak Hourly Demand (L/s)	0.17
OBC Fire Flow Requirement (L/s)	45.00
FUS Fire Flow Requirement (L/s)	100.00
Max Day + Fire Flow (L/s)	100.10

The City provided both the estimated minimum and maximum water pressures, as well as the estimated water pressure during fire flow demand for the demands indicated by the correspondence in Appendix 'C'. Site plan changes have resulted in a minor reduction in water demands, however this isn't anticipated to impact the design. As shown in Table 2 below, the minimum and maximum pressures fall within the required range identified in the City of Ottawa Water Supply guidelines.



Table 2: Boundary Conditions Results

Scenario	m H2O	Pressure (kPa)
Minimum HGL	159.9	330.6
Maximum HGL	156.6	298.2
Maximum Daily + Fire Flow Demand (217 L/s)	156.4	296.3

To confirm the adequacy of fire flow to protect the proposed development, public and private fire hydrants within 150 m of the proposed building were accounted for per the City of Ottawa ISTB 2018-02. A location map showing the hydrant proximities to the site can be found in Appendix 'C'. A hydrant summary can be seen in Table 3, below.

Table 3: Fire Protection Confirmation

Building	Fire Flow Demand (L/min.)	Fire Hydrant(s) within 75m	Fire Hydrant(s) within 150m	Combined Fire Flow (L/min.)
1037 Carp Road	6,000	2	1	13,300

Based on City guidelines the existing hydrants located in the vicinity can provide adequate fire protection for the site.



## 5.0 SANITARY DESIGN

### 5.1 Existing Sanitary Sewer

There is an existing private 150mm diameter concrete sanitary forcemain within the right of way, which is not available to service the site. This sewer is tributary to the Stittsville trunk sewer.

### 5.2 Proposed Sanitary Sewer

A new septic bed located within the south side yard will be installed and sized to accommodate the development. McIntosh Perry will coordinate with the Ottawa Septic System Office for the required permits and approvals.

#### Private Sewage Systems

- Approval for on-site septic treatment will be governed by the OBC as it is understood that the Daily Design Flow proposed commercial office building will be approximately 6,720 litres per day (i.e. less than 10,000 litres per day).
- It is recommended that the proposed commercial development be serviced with Class 4 sewage systems with leaching beds constructed to discharge within the native sand as is present throughout the Site.
- Any septic systems must be constructed with all appropriate setbacks, treatment units and stipulations as per applicable Ontario Regulations.

#### Servicing Layout

- The proposed development and associated new Class 4 sewage system should follow the layout included in the Site Plan application.

#### Maintaining Groundwater Recharge

- Given that the Site lies within an area identified as high recharge within the Carp River Subwatershed Study, stormwater criteria for the development of the site are based on the pre-consultation notes provided by the City of Ottawa staff on November 18th, 2019, where post-development drainage rates must meet pre-development drainage conditions. Existing drainage patterns for the site are being maintained in accordance with the City's criteria. Best management practices are provided in the proposed development plans with regards to the on-site infiltration. The swale system and storage area will provide an opportunity for detention and infiltration of stormwater. In addition, the proposed on-site septic system has been designed for 6,270 L/d, allowing for additional groundwater recharge through infiltration within the sewage system's leaching bed.

For further design information pertaining to the on-site sewage disposal system, please refer to the septic system application.

See Sanitary Sewer Design in Appendix ‘D’ of this report for more details.

## 6.0 PROPOSED STORMWATER MANAGEMENT

### 6.1 Design Criteria and Methodology

The existing site sheet drains to Carp Road and to the rear of the property, where it is conveyed to the City sewers system via a swale and inlet catchbasin. As indicated by the pre consultation, existing flow patterns are to be maintained. Runoff from the parking lot and swales will be directed to a depressed storage area located at the northeast corner of the site. The flow will be restricted at the outlet of the depressed storage area before leaving the site. The emergency overland flow route for the proposed site will be directed northeast towards the existing swale. The quantitative and qualitative properties of the storm runoff for both the pre & post development flows are further detailed below. Stormwater Best Management Practices (SWM BMP's) will be implemented at the “Lot level”, “Conveyance” and “End of Pipe” locations. These concepts will be explained further in Section 6.6.

In summary, the following design criteria have been employed in developing the stormwater management design for the site as directed by the MVCA and the City:

#### Quality Control

- Best management practices have been implemented to promote settling of suspended solids removal using grassed swales and a grassed depressed storage area.

#### Quantity Control

- Post-development flow 5/100-year is to be restricted to match the 5/100-year pre-development flow with a maximum C value of 0.50.

### 6.2 Runoff Calculations

Runoff calculations presented in this report are derived using the Rational Method, given as:

$$Q = 2.78CIA \text{ (L/s)}$$

Where	C	= Runoff coefficient
	I	= Rainfall intensity in mm/hr (City of Ottawa IDF curves)
	A	= Drainage area in hectares

It is recognized that the Rational Method tends to overestimate runoff rates. As a result, the conservative calculation of runoff ensures that any SWM facility sized using this method is expected to function as intended.

The following coefficients were used to develop an average C for each area:

Roofs/ Concrete/ Asphalt	0.90
Grass	0.20

As per the City of Ottawa - Sewer Design Guidelines, the 5-year balanced 'C' value must be increased by 25% for a 100-year storm event to a maximum of 1.0.

### 6.3 Pre-Development Drainage

Based on the criteria listed in Section 7.1, the development will be required to restrict the 5 and 100-year flows to 21.56 L/s and 40.72 L/s, respectively.

It has been assumed that the existing development contained no stormwater management controls for flow attenuation. The estimated pre-development peak flows for the 5 and 100-year events are summarized below in Table 4.

Table 4: Pre-Development Runoff Summary

Drainage Area	Area (ha)	Q (L/s)	
		5-Year	100-Year
A1	0.27	21.91	46.93

See CP-19-0125 - PRE in Appendix 'E' for pre-development drainage areas and Appendix 'G' for calculations.

### 6.4 Post-Development Drainage

The proposed site drainage limits are demonstrated on the Post-Development Drainage Area Plan. See CP-19-0125 - POST in Appendix 'F' of this report for more details. A summary of the Post-Development Runoff Calculations can be found below.

Table 5: Post-Development Runoff Summary

Drainage Area	Area (ha)	Runoff Coefficient (5-Year)	Runoff Coefficient (100-Year)	5-Year Peak Flow (L/s)	100-Year Peak Flow (L/s)
B1	0.05	0.90	1.00	13.40	25.51
B2	0.09	0.84	0.94	21.85	41.69
B3	0.08	0.20	0.25	4.49	9.62
B4	0.02	0.22	0.27	1.22	2.58
B5	0.01	0.39	0.45	0.94	1.88
B6	0.03	0.42	0.49	3.07	6.09
Total	0.27			44.97	87.37

See Appendix 'G' for calculations. Runoff for areas B1-B5 will be restricted before leaving site. The flow will be restricted, and the required storage will be provided within the depressed storage area. The flow will be controlled by a 150 mm diameter outlet pipe and weir at the outlet of the depressed storage area. The

restriction of flow from areas B1-B5 will compensate for the unrestricted flow (Area B6) leaving the site. This quantity and quality control will be further detailed in Sections 6.5 and 6.6.

## 6.5 Quantity Control

Based on the pre-consultation notes, post-development runoff for this site has been restricted to match the total pre-development flow rate with a combined Cvalue of 0.28. (See Appendix 'B' for pre-consultation notes).

See Appendix 'G' for calculations.

Reducing site flows will be achieved using flow restrictions and will create the need for onsite storage. Runoff from areas B1 to B5 will be restricted as shown in the table below.

Table 6: Post-Development Restricted Runoff Summary

Drainage Area	Unrestricted Flow (L/S)		Restricted Flow (L/S)		Storage Required (m <sup>3</sup> )		Storage Provided (m <sup>3</sup> )	
	5-year	100-Year	5-Year	100-Year	5-Year	100-Year	5-Year	100-Year
B1	13.40	25.51	18.49	34.63	14.10	28.21	14.22	31.05
B2	21.85	41.69						
B3	4.49	9.62						
B4	1.22	2.58						
B5	0.94	1.88						
B6	3.07	6.09	3.07	6.09				
Total	44.97	87.37	21.56	40.72				

See Appendix 'G' for calculations.

Runoff from Area B1 to B5 will be restricted through a 150 mm diameter outlet pipe and a 1 m wide weir located at the outlet of the depressed storage area. The total flow leaving the depressed area will be 18.49 L/s and 34.63 L/s during the 5 and 100-year storm events, respectively. This will result in ponding depths of 23 and 36 cm for the 5 and 100-year storm events, respectively. Approximately 28.21 m<sup>3</sup> of storage will be required on site to attenuate flow to the established release rate of 34.63 L/s. Storage for this area will be located in the depressed storage area. Runoff from area B6 will be unrestricted and flow towards the back of the site before traveling off site to the exiting swale. See Table 7, below, for additional information on storage volumes.

Table 7: Storage Summary

Drainage Area	Depth of Ponding (m)	Storage Required (m <sup>3</sup> )	Storage Available (m <sup>3</sup> )	Depth of Ponding (m)	Storage Required (m <sup>3</sup> )	Storage Available (m <sup>3</sup> )
	5-Year			100-Year		
B1-B5	0.23	14.10	14.22	0.36	28.21	31.05

See Appendix 'G' for calculations.

In the event there is a rainfall above the 100-year storm event, an emergency overland flow route has been provided so that the storm water runoff will be conveyed over the northeast side of the storage area and flow off site directly to the existing swale at the back of the site.

## 6.6 Quality Control

The development of this lot will employ Best Management Practices (BMP's) wherever possible. The intent of implementing stormwater BMP's is to ensure that water quality and quantity concerns are addressed at all stages of development. Lot level BMP's typically include temporary retention of the parking lot runoff, minimizing ground slopes and maximizing landscaped areas. Some of these BMP's cannot be provided for this site due to site constraints and development requirements.

A 150 mm diameter outlet pipe located at the outlet of the depressed storage area will restrict flows from the site, causing temporary ponding within the depressed storage area. There will be an opportunity for particle settlement during this process. The City sewer system is tributary to the EcoWoods Pond where additional quality treatment is provided.

## 7.0 EROSION AND SEDIMENT CONTROL

### 7.1 Temporary Measures

Before construction begins, temporary silt fence, straw bale or rock flow check dams will be installed at all natural runoff outlets from the property. It is crucial that these controls be maintained throughout construction and inspection of sediment and erosion control will be facilitated by the Contractor or Contract Administration staff throughout the construction period.

Silt fences will be installed where shown on the final engineering plans, specifically along the downstream property limits. The Contractor, at their discretion or at the instruction of the City, Conservation Authority or the Contract Administrator shall increase the quantity of sediment and erosion controls on-site to ensure that the site is operating as intended and no additional sediment finds its way off site. The rock flow, straw bale & silt fence check dams and barriers shall be inspected weekly and after rainfall events. Care shall be taken to properly remove sediment from the fences and check dams as required. Fibre roll barriers are to be installed at all existing curb inlet catchbasins and filter fabric is to be placed under the grates of all existing catchbasins and manholes along the frontage of the site and any new structures immediately upon installation. The measures for the existing/proposed structures is to be removed only after all areas have been paved. Care shall be taken at the removal stage to ensure that any silt that has accumulated is properly handled and disposed of. Removal of silt fences without prior removal of the sediments shall not be permitted.

Although not anticipated, work through winter months shall be closely monitored for erosion along sloped areas. Should erosion be noted, the Contractor shall be alerted and shall take all necessary steps to rectify the situation. Should the Contractor's efforts fail at remediating the eroded areas, the Contractor shall contact the City and/or Conservation Authority to review the site conditions and determine the appropriate course of action. As the ground begins to thaw, the Contractor shall place silt fencing at all required locations as soon as ground conditions warrant. Please see the Site Grading, Drainage and Sediment & Erosion Control Plan for additional details regarding the temporary measures to be installed and their appropriate OPSD references.

### 7.2 Permanent Measures

Rip-rap will be placed at all locations that have the potential for concentrated flow. It is crucial that the Contractor ensure that the geotextile is keyed in properly to ensure runoff does not undermine the rip rapped area. Additional rip rap is to be placed at erosion prone locations as identified by the Contractor / Contract Administrator / City or Conservation Authority.

It is expected that the Contractor will promptly ensure that all disturbed areas receive topsoil and seed/ sod and that grass be established as soon as possible. Any areas of excess fill shall be removed or levelled as soon as possible and must be located a sufficient distance from any watercourse to ensure that no sediment is washed out into the watercourse. As the vegetation growth within the site provides a key component to the control of sediment for the site, it must be properly maintained once established. Once the construction is complete, it will be up to the landowner to maintain the vegetation and ensure that the vegetation is not overgrown or impeded by foreign objects.

## 8.0 SUMMARY

- A new 513.84 m<sup>2</sup> two-storey office building will be constructed at 1037 Carp Road;
- The FUS method estimated fire flow indicated 6000 L/min is required for the proposed development;
- A new 150 mm diameter watermain will be installed to service the site, connecting to the watermain on Carp Road;
- A new septic system will be installed to service the proposed site;
- Stormwater will sheet flow towards proposed swales which will be directed towards the depressed storage area before outletting of site at the northeast corner of the site;
- Storage for the 5 through 100-year storm events will be provided within the depressed storage area and be controlled with a 150 mm outlet pipe and weir; and
- The depressed storage area will promote particle settlement before entering the existing ditch off site.



## 9.0 RECOMMENDATION

Based on the information presented in this report, we recommend that City of Ottawa approve this Servicing and Stormwater Management Report in support of the proposed Office Building at 1037 Carp Road.

This report is respectfully being submitted for approval.

Regards,

McIntosh Perry Consulting Engineers Ltd.



Robert Freel, P.Eng.  
Senior Project Manager, Land Development  
T: 613.714.6174  
E: [r.freel@mcintoshperry.com](mailto:r.freel@mcintoshperry.com)

*Francis Valenti*

Francis Valenti, EIT.  
Engineering Intern, Land Development  
T: 613.808.2123  
E: [f.valenti@mcintoshperry.com](mailto:f.valenti@mcintoshperry.com)

## 10.0 STATEMENT OF LIMITATIONS

This report was produced for the exclusive use of Jim Bell Architectural Design Inc. The purpose of the report is to assess the existing stormwater management system and provide recommendations and designs for the post-construction scenario that are in compliance with the guidelines and standards from the Ministry of the Environment, Conservation and Parks, City of Ottawa and local approval agencies. McIntosh Perry reviewed the site information and background documents listed in Section 2.0 of this report. While the previous data was reviewed by McIntosh Perry and site visits were performed, no field verification/measures of any information were conducted.

Any use of this review by a third party, or any reliance on decisions made based on it, without a reliance report is the responsibility of such third parties. McIntosh Perry accepts no responsibility for damages, if any, suffered by any third party as a result of decisions or actions made based on this review.

The findings, conclusions and/or recommendations of this report are only valid as of the date of this report. No assurance is made regarding any changes in conditions subsequent to this date. If additional information is discovered or becomes available at a future date, McIntosh Perry should be requested to re-evaluate the conclusions presented in this report, and provide amendments, if required.

**APPENDIX A  
SITE LOCATION PLAN**





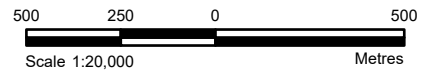

CITY OF OTTAWA

Site Location



LEGEND

-  Site Location
-  Watercourse
-  Local Road
-  Waterbody
-  Major Road
-  Wooded Area

REFERENCE

GIS data provided by the Ontario Ministry of Natural Resources and Forestry, 2021.

CLIENT:	PROJECT 1 STUDIOS	
PROJECT:	PHASE I ESA 1037 CARP ROAD, OTTAWA, ON	
TITLE:	SITE LOCATION PLAN	
<b>McINTOSH PERRY</b> 115 Walgreen Road, RR3, Carp, ON K0A1L0 Tel: 613-836-2184 Fax: 613-836-3742 www.mcintoshperry.com	PROJECT NO: CCO-19-0125	FIGURE:
	Date	Aug., 18, 2021
	Checked By	BS
		<b>1</b>

C:\Users\stunum\Documents\Projects\2019\CCO\CCO-19-0125\Mapa\LandDevelopment\CCO-19-0125\_LandDevelopment\_OptionD.aprx

**APPENDIX B**  
**CITY OF OTTAWA PRE-CONSULTATION NOTES**

**1037 Carp Road**  
**Pre-application Consultation Meeting Notes**

Location: Room 4102E, City Hall  
Date: November 18, 2019

**Attendees:** Colette Gorni, Planner, City of Ottawa  
Justin Armstrong, Engineering Intern (Infrastructure), City of Ottawa  
Josiane Gervais, Project Manager (Transportation), City of Ottawa  
Mark Richardson, Planning Forester, City of Ottawa  
Matthew Ippersiel, Planner (Urban Design), City of Ottawa  
Debbie Belfie, Planner, DG Belfie Planning and Development Consulting Ltd.  
Jim Bell, Architect, Jim Bell Architecture Design Inc.

**Regrets:** Matthew Hayley, Environmental Planner, City of Ottawa  
Justyna Garbos, Planner (Parks), City of Ottawa

**Comments from the Applicant**

1. The applicant is proposing to construct two 2-storey office buildings and an associated parking lot. The buildings are to be developed in two phases.
2. At the time of purchase, the now-owner was informed that there were sanitary services on this portion of Carp Road. It was not until the applicant first requested a pre-application consultation meeting in August 2019, that they were made aware that the sanitary sewer along Carp Road is a trunk sanitary sewer and connection to a trunk is not possible. As a result, the site requires private services to be developed. A private septic system is proposed.
3. The Official Plan (OP) has policies that do not allow for private services in the public service area. However, there is an exception in the OP that allows for a single building comprised of a commercial use to connect to private services in certain situations.
4. The proposed development has been significantly scaled back in order to meet the requirements of the OP exception. The Phase 1 building is now much smaller than originally proposed.
5. The Phase 2 lands are to remain vacant until such a time that sanitary services are accessible. At this time, the Phase 1 Building may be expanded and/or redeveloped.

**Planning Comments**

1. This is a formal pre-application consultation meeting for a “New – Site Plan Control Application – Standard”. Application form, timeline and fees can be found [here](#).

2. Cash-in-lieu of parkland will be required as a condition of approval, as per the [Parkland Dedication By-law](#). Parks will take cash-in-lieu of parkland equivalent to 2% of the value of the development area.
3. Please look for more opportunities for tree retention. As the Phase 2 lands are not to be developed for quite some time, these trees should be retained in the meantime.
4. Ensure that dimensions related to zoning provisions are shown on site plan (i.e. parking stall size).
5. Provide a rationale for the private servicing in a public service area in the planning rationale. The exception should be identified, as well as reasoning for why it is necessary, and steps taken to address the OP policies.
6. Please reach out to the applicable Ward Councillor and set up a meeting to present plans for the site.

#### Urban Design Comments

6. There is general support for the site layout and especially for locating the building(s) towards the front property line to help frame the street.
7. The design team is strongly encouraged to include more or larger windows on the building façade facing Carp Road. Avoid having a predominantly blank wall face the public realm. Additional urban design comments will be provided once the elevations are provided. Please ensure they detail materials and colours.
8. Retaining a landscaping buffer at the rear of the property is a good gesture to the neighbouring residential buildings and it is a feature that should be retained in future plans.
9. As the rear of the building will effectively be facing towards and in close proximity to the side property line, consider what relationship it will create with the neighbouring property. As shown, the rear doors will open four feet from the property line. Will they connect to a paved walkway that wraps fully around the building? Will trees be retained in this location to screen it from the neighbouring property? Will there be a fence to screen the walkway?

#### Transportation Comments

1. Follow Traffic Impact Assessment Guidelines
  - Screening form to start, full Traffic Impact Assessment if any of the triggers on the screening form are satisfied.



- Start this process asap. The application will not be deemed complete until the submission of the draft step 1-4, including the functional draft RMA package (if applicable) and/or monitoring report (if applicable).
  - Request base mapping asap if RMA is required. Contact Engineering Services (<https://ottawa.ca/en/city-hall/planning-and-development/engineering-services>)
2. ROW protection on Carp Rd between Stittsville urban area north limit and Hazeldean is 37.5m even.
  3. Clear throat requirements for offices that are <5,000 m<sup>2</sup> on an arterial is 15m (see TAC Table 8.9.3).
  4. Noise Impact Study required for the following:
    - Stationary (if there will be any exposed mechanical equipment due to the proximity to neighboring noise sensitive land uses)
  5. On site plan:
    - Show all details of the roads abutting the site up to and including the opposite curb; include such items as pavement markings, accesses and/or sidewalks.
    - Turning templates will be required for all accesses showing the largest vehicle to access the site; required for internal movements and at all access (entering and exiting and going in both directions).
    - Show all curb radii measurements; ensure that all curb radii are reduced as much as possible
    - Show lane/aisle widths.
    - Grey out any area that will not be impacted by this application.
  6. AODA legislation is in effect for all organizations, please ensure that the design conforms to these standards (see attached checklist).

Feel free to contact Josiane Gervais, Transportation Project Manager, for follow-up questions.

### Engineering Comments

#### **Water**

1. Water is available along Carp Road.

2. A watermain boundary condition request should be made for the proposed connection to the City watermain. As part of the request, anticipated domestic demands and FUS fireflow requirements (with calculations shown) should be provided along with a screenshot of the proposed connection location. The request can be sent to [justin.armstrong@ottawa.ca](mailto:justin.armstrong@ottawa.ca).

## **Sanitary**

3. Future sanitary sewer extensions along Carp Road have not been confirmed. If sanitary sewers are to be extended along Carp, extensions are not anticipated prior to 2031.
4. As there is no sanitary sewer available in Carp Road, the site will need to be serviced privately via a septic system. Although within the public service area, as per Section 2.3.2, Policy 14 of the Official Plan, where no provision for public services exists, the City may permit development on private services in defined Public Service Areas provided that it can be demonstrated to the satisfaction of the City that such development:
  - a. Is proposed in a circumstance where public services are not currently technically or financially feasible;
  - b. Can adequately be serviced by private individual services in accordance with Section 4.4;
  - c. Is of a minor nature that consists of a single building comprising a commercial, institutional or public use; residential infilling within residential clusters; a farm severance as provided for in Section 3.7.3 of this Plan or other uses of similar nature and scale;
  - d. Will not compromise the longer-term development of the area on public services.Items b. and c. will need to be demonstrated/justified as part of the site servicing submissions for the proposed development.
5. A Septic Impact Assessment is required in order to ensure that the proposed septic system does not contaminate the groundwater that is used as a source of drinking water in the surrounding area. The Septic Impact Assessment should confirm that the impact is acceptable and should identify the type of proposed septic system, level of treatment, amount of septic flow based on employment or building specs, impermeable land cover, proposed stormwater management/infiltration features, etc. There are several additional 'tools' to help ensure that there is sufficient nitrate dilution onsite specific for the Carp Road Corridor outlined in a memo dated September 26, 2016. If the consultant is unaware of the memo or for more details regarding the Septic Impact Assessment requirement, please contact Tessa Di Iorio at extension 17658 or at [tessa.diiorio@ottawa.ca](mailto:tessa.diiorio@ottawa.ca). If the septic system treats over 10,000 L/day, an ECA will be required and the MECP will review the Impact Assessment.
6. The size and location of the proposed building will likely be governed by the septic system's ability to adequately treat the sewage flows (i.e. findings of the Septic

Impact Assessment – larger building = more sewage to treat) and required offsets between the proposed septic system and the proposed building, neighbouring lots/buildings, wells, etc.

7. Proof of approval from the Ottawa Septic System Office (OSSO) will be required for the proposed septic system.
8. Mississippi Valley Conservation Authority should be consulted regarding any requirements they may have.

### **Storm**

9. Post-development peak flows for the site will need to be controlled to pre-development peak flows. The existing drainage patterns for the site must be maintained. It is imperative that additional runoff is not directed to any neighbouring property.

Feel free to Contact Justin Armstrong, Infrastructure Project Manager, for follow-up questions.

### Forestry Comments

#### **TCR requirements:**

1. a Tree Conservation Report (TCR) must be supplied for review along with the suite of other plans/reports required by the City; an approved TCR is a requirement for Site Plan approval
2. any removal of privately-owned trees 10cm or larger in diameter requires a tree permit issued under the Urban Tree Conservation Bylaw; the permit is based on the approved TCR
3. any removal of City-owned trees will require the permission of Forestry Services who will also review the submitted TCR
4. for this site, the TCR may be combined with the Landscape Plan provided all information is clearly displayed
  - a. if possible, please submit separate plans showing 1) existing tree inventory, and 2) a plan showing to be retained and to be removed trees with tree protection details
5. the TCR must list all trees on site by species, diameter and health condition – separate stands of trees may be combined using averages

6. Butternut trees are a regulated species under the Endangered Species Act and may be present on site – all butternut should be addressed within the TCR
7. the TCR must address all trees with a critical root zone that extends into the developable area – all trees that could be impacted by the construction that are outside the developable area need to be addressed.
8. trees with a trunk that crosses/touches a property line are considered co-owned by both property owners; permission from the adjoining property owner must be obtained prior to the removal of co-owned trees
9. If trees are to be removed, the TCR must clearly show where they are, and document the reason they can not be retained – please provide a plan showing retained and removed treed areas
10. All retained trees must be shown and all retained trees within the area impacted by the development process must be protected as per City guidelines listed on Ottawa.ca
  - a. The location of tree protection fencing must be shown on a plan
  - b. Include distance indicators from the trunk of the retained tree to the nearest part of the tree protection fencing
  - c. Show the critical root zone of the retained trees
  - d. If excavation will occur within the critical root zone, please show the limits of excavation and calculate the percentage of the area that will be disturbed
11. the City encourages the retention of healthy trees; if possible, please seek opportunities for retention of trees that will contribute to the design/function of the site.
12. Tree removal should be restricted to areas that are required for site development of this phase only.
13. Tree removal restrictions to accommodate for nesting birds will be in place from April 1 to August 15.
14. Please ensure newly planted trees have an adequate soil volume for their size at maturity.
15. For more information on the process or help with tree retention options, contact Mark Richardson [mark.richardson@ottawa.ca](mailto:mark.richardson@ottawa.ca)

Environmental Comments

1. The only trigger for an EIS is potential species at risk, namely the butternut tree. Accordingly, if the TCR includes butternut, an EIS is not required.

Sincerely,

A handwritten signature in cursive script that reads "Colette Gorni".

Colette Gorni  
Planner I  
Development Review - West

**APPENDIX C**  
**WATERMAIN CALCULATIONS**

## Boundary Conditions 1037 Carp Road

### Provided Information

Scenario	Demand	
	L/min	L/s
Average Daily Demand	4	0.07
Maximum Daily Demand	6	0.10
Peak Hour	11	0.18
Fire Flow Demand #1	3,000	50.00

### Location



### Results

#### Connection 1 – Carp Rd.

Demand Scenario	Head (m)	Pressure <sup>1</sup> (psi)
Maximum HGL	159.9	47.9
Peak Hour	156.6	43.2
Max Day plus Fire 1	156.4	42.8

<sup>1</sup> Ground Elevation = 126.2 m



**Disclaimer**

*The boundary condition information is based on current operation of the city water distribution system. The computer model simulation is based on the best information available at the time. The operation of the water distribution system can change on a regular basis, resulting in a variation in boundary conditions. The physical properties of watermains deteriorate over time, as such must be assumed in the absence of actual field test data. The variation in physical watermain properties can therefore alter the results of the computer model simulation. Fire Flow analysis is a reflection of available flow in the watermain; there may be additional restrictions that occur between the watermain and the hydrant that the model cannot take into account.*

# McINTOSH PERRY

## 000-19-0125 - 1037 Carp Road - Water Demands

Project:	1037 Carp Road
Project No.:	000-19-0125
Designed By:	B.G.S
Checked By:	R.D.F
Date:	July 15, 2022
Ste Area:	0.27 gross ha
Office Units	14 units
Office Area	513.84 m <sup>2</sup>

### AVERAGE DAILY DEMAND

DEMAND TYPE	AMOUNT	UNITS
Residential	280	L/c/d
Industrial - Light	35,000	L/gross ha/d
Industrial - Heavy	55,000	L/gross ha/d
Office	75	L/(7m <sup>2</sup> /d)
Amenity Space	2,500	L/(1000m <sup>2</sup> /d)
Hospital	900	L/(bed/day)
Schools	70	L/(Student/d)
Trailer Parks no Hook-Ups	340	L/(space/d)
Trailer Park with Hook-Ups	800	L/(space/d)
Campgrounds	225	L/(campsite/d)
Mobile Home Parks	1,000	L/(Space/d)
Motels	150	L/(bed-space/d)
Hotels	225	L/(bed-space/d)
Tourist Commercial	28,000	L/gross ha/d
Othe Commercial	28,000	L/gross ha/d
<b>AVERAGE DAILY DEMAND</b>	<b>3.82</b>	<b>L/min</b>
	<b>5.51</b>	<b>m<sup>3</sup>/day</b>

### MAXIMUM DAILY DEMAND

DEMAND TYPE	AMOUNT	UNITS
Residential	2.8 avg. day	L/c/d
Industrial	1.5 x avg. day	L/gross ha/d
Commercial	1.5 x avg. day	L/gross ha/d
Institutional	1.5 x avg. day	L/gross ha/d
<b>MAXIMUM DAILY DEMAND</b>	<b>5.73</b>	<b>L/min</b>
	<b>8.26</b>	<b>m<sup>3</sup>/day</b>

### MAXIMUM HOUR DEMAND

DEMAND TYPE	AMOUNT	UNITS
Residential	5.4 x avg. day	L/c/d
Industrial	1.8 x max. day	L/gross ha/d
Commercial	1.8 x max. day	L/gross ha/d
<b>MAXIMUM HOUR DEMAND</b>	<b>10.32</b>	<b>L/min</b>
	<b>14.86</b>	<b>m<sup>3</sup>/day</b>

### WATER DEMAND DESIGN FLOWS PER UNIT COUNT

CITY OF OTTAWA - WATER DISTRIBUTION GUIDELINES, JULY 2010

FOR POPULATIONS BELOW 501, MOE DESIGN GUIDELINES FOR DRINKING WATER SYSTEMS USED

# McINTOSH PERRY

## 000-19-0125 - 1037 Carp Road - OBC Fire Calculations

Project:	1037 Carp Road
Project No.:	000-19-0125
Designed By:	B.G.S
Checked By:	R.D.F
Date:	July 15, 2022

### Ontario 2006 Building Code Compendium (Div. B - Part 3)

#### Water Supply for Fire-Fighting - Office Building

Building is classified as Group : D - Business and Personal Services O

Building is of combustible construction with fire separations and fire resistance ratings provided in accordance with Subsection 3.2.2., including loadbearing walls, columns and arches. Noncombustible construction may be used in lieu of fire-resistance rating

From Div. B A-3.2.5.7. of the Ontario Building Code - 3. Building On-Site Water Supply:

(a)  $Q = K \times V \times S_{tot}$

where:

Q = minimum supply of water in litres

K = water supply coefficient from Table 1

V = total building volume in cubic metres

S<sub>tot</sub> = total of spatial coefficient values from the property line exposures on all sides as obtained from the formula:

$S_{tot} = 1.0 + [S_{side1} + S_{side2} + S_{side3} + \dots \text{etc.}]$

K	18	(from Table 1 pg A-31)
V	2,689	(Total building volume in m <sup>3</sup> .)
S <sub>tot</sub>	2.0	(From figure 1 pg A-32)
Q =	96,803.28 L	



			From Figure 1 (A-32)
S <sub>north</sub>	2.5 m	0.5	
S <sub>east</sub>	9.5 m	0.0	
S <sub>south</sub>	30.1 m	0.0	
S <sub>west</sub>	4.8 m	0.5	

\* approximate distances

#### From Table 2: Required Minimum Water Supply Flow Rate (L/s)

2700 L/min (if Q < 108,000 L)  
713 gpm



# McINTOSH PERRY

## CCO-19-0125 - 1037 Carp Road - CITY OF OTTAWA BOUNDARY CONDITION RESULTS

---

Project: 1037 Carp Road  
Project No.: CCO-19-0125  
Designed By: B.G.S  
Checked By: R.D.F  
Date: August 17, 2021

---

### Boundary Conditions Unit Conversion

---

Scenario	Height (m)	Elevation (m)	m H <sub>2</sub> O	PSI	kPa
Avg. DD	159.9	126.2	33.7	47.9	330.6
Fire Flow (200 L/s)	156.6	126.2	30.4	43.3	298.2
Peak Hour	156.4	126.2	30.2	43.0	296.3

# 1037 Carp Road Hydrant Proximities

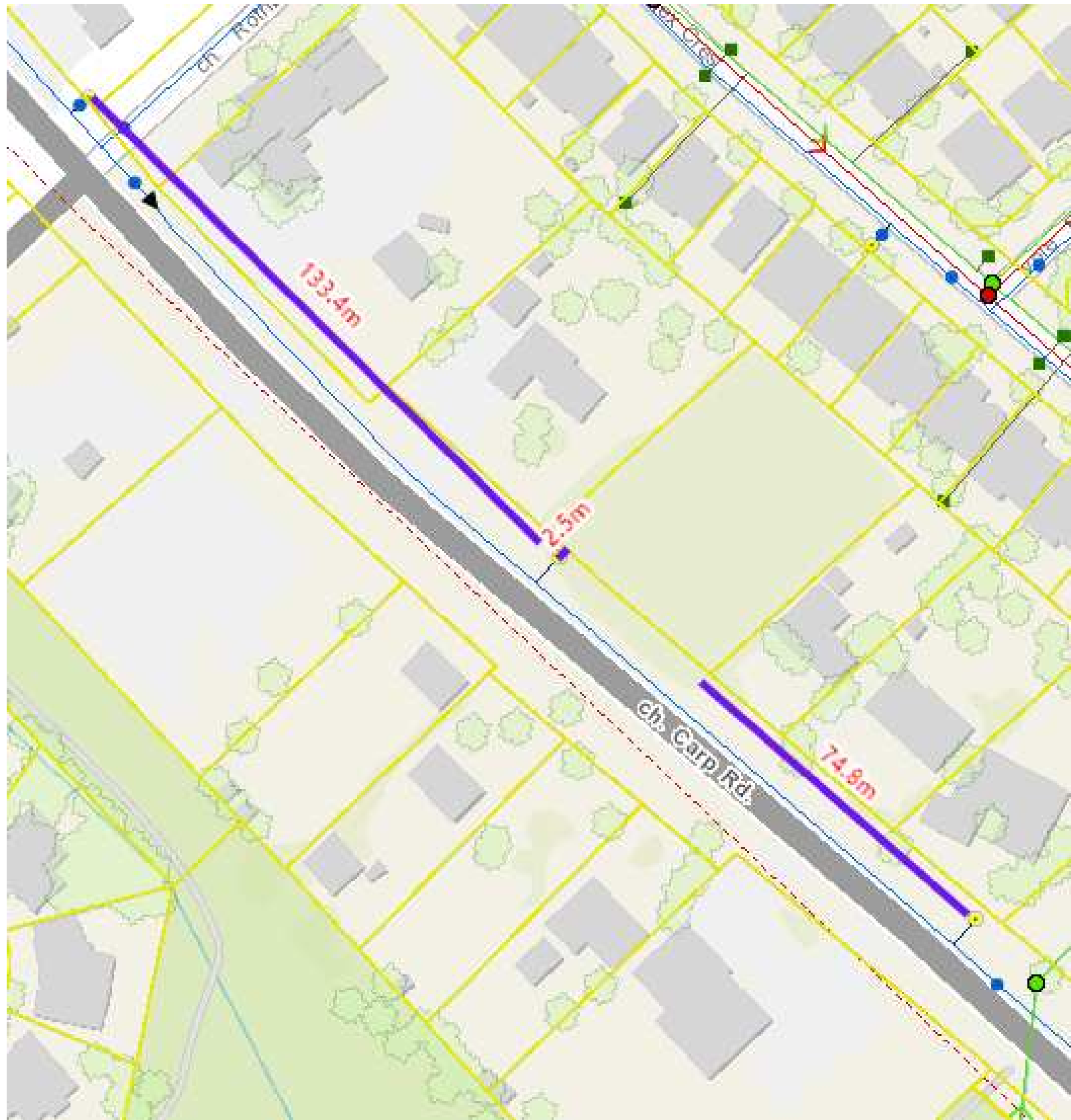

**APPENDIX D**  
**SANITARY CALCULATIONS**



# SEPTIC IMPACT ASSESSMENT (REV.1) OFFICE BUILDING – 1037 CARP ROAD

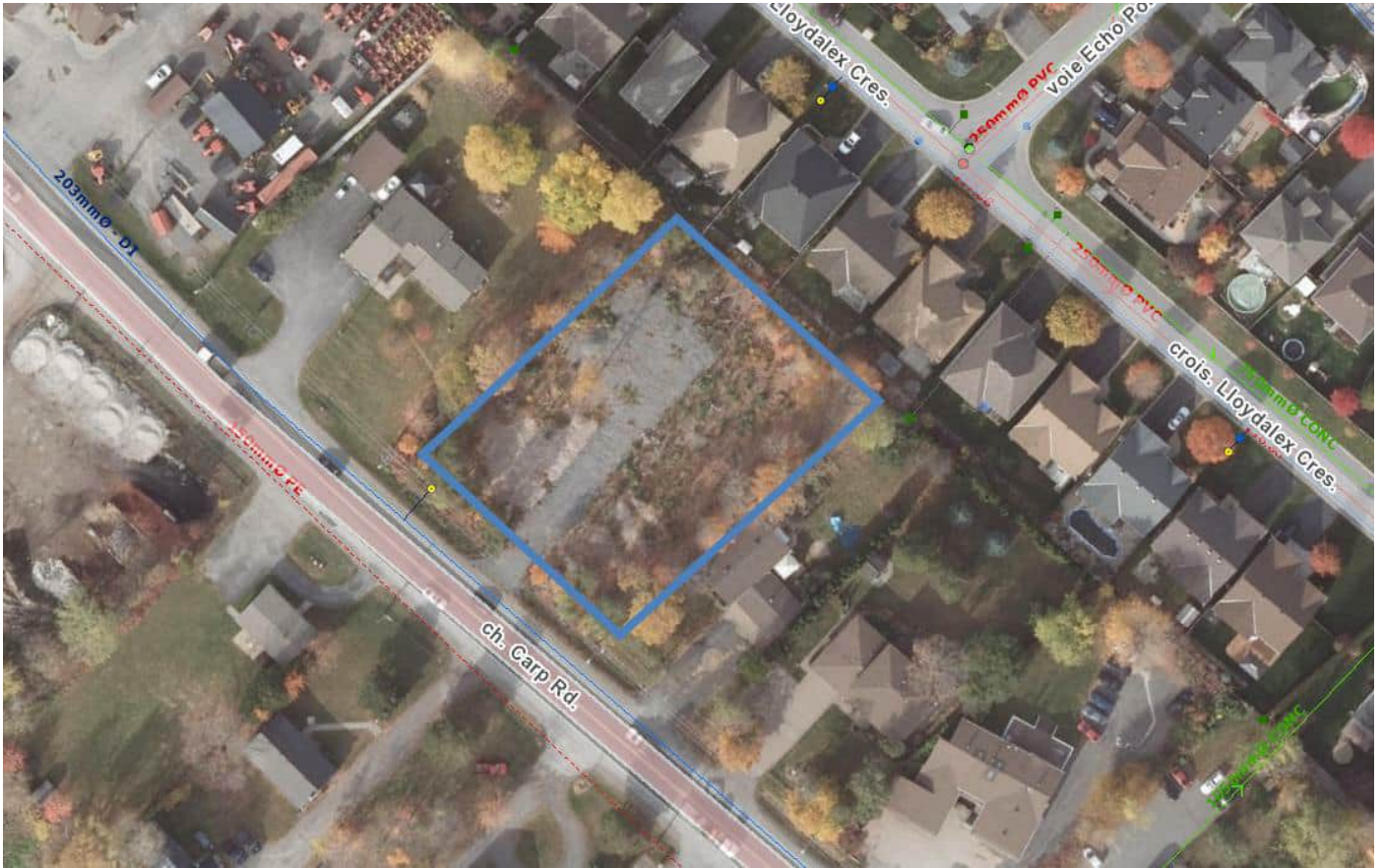

Project No.: CP-19-0125  
City File No.: D07-12-21-0162

Prepared for:

Jim Bell Architecture Design Inc.  
26 Bert G Argue Drive  
Stittsville, ON K2S 1X9

Prepared by:

McIntosh Perry Consulting Engineers Ltd.  
115 Walgreen Road  
Carp, ON K0A 1L0

Revision 1: November 28, 2022  
Original: October 4, 2021

## TABLE OF CONTENTS

<b>1.0</b>	<b>INTRODUCTION .....</b>	<b>3</b>
1.1	<i>Site Description.....</i>	3
1.2	<i>Existing Conditions and Infrastructure.....</i>	3
1.3	<i>Proposed Development and Statistics .....</i>	4
<b>2.0</b>	<b>INVESTIGATION .....</b>	<b>4</b>
2.1	<i>Site Setting .....</i>	4
2.2	<i>Neighbouring Properties and Land Uses.....</i>	4
2.3	<i>Hydrology and Hydrogeology.....</i>	4
2.4	<i>Water Well Record Review.....</i>	5
2.5	<i>Background Geology and Hydrology .....</i>	6
2.5.1	Ontario Geological Survey (OGS) – Surficial Geology .....	6
2.5.2	Ontario Geological Survey (OGS) – Bedrock Geology .....	6
<b>3.0</b>	<b>TERRAIN ANALYSIS .....</b>	<b>7</b>
3.1	<i>On-Site Investigation .....</i>	7
3.2	<i>Site Evaluation.....</i>	7
3.2.1	Overburden Depth .....	7
3.2.2	Overburden Characterization .....	7
3.2.3	Soil Classification for Private Sanitary Servicing .....	9
3.2.4	Groundwater .....	9
3.2.5	Bedrock .....	10
3.2.6	Recharge and Discharge Areas .....	10
3.2.7	Hydrogeologically Sensitive Areas .....	10
<b>4.0</b>	<b>SEPTIC IMPACT ASSESSMENT .....</b>	<b>10</b>
<b>5.0</b>	<b>RECOMMENDATIONS.....</b>	<b>12</b>
5.1	<i>Wastewater Servicing.....</i>	12
<b>6.0</b>	<b>LIMITATIONS .....</b>	<b>12</b>
<b>7.0</b>	<b>REFERENCES .....</b>	<b>14</b>

## **FIGURES**

Figure 1 - Site Location Plan

Figure 2 - Study Area and Surrounding Land Use

Figure 3 - Drainage and Topography

Figure 4 - MECP Well Record Summary

Figure 5 - Shallow Groundwater Contours and Flow Direction

## **APPENDICES**

Appendix A - Geotechnical Report

Appendix B – Monitoring Well Logs

## **1.0 INTRODUCTION**

McIntosh Perry (MP) was retained by Jim Bell Architectural Design Inc. to conduct a Sewage System Impact Assessment Report for the Site located at 1037 Carp Road, Carp, Ontario (the Site, Figure 1). It is our understanding that the Client wishes to construct a sewage system to service the proposed office building at the Site, which has triggered the need for a Site Plan Control Application. As part of pre-consultation with the City of Ottawa, it was identified that a Septic Impact Assessment was required to ensure that the proposed septic system does not impact the groundwater should it be used as a source of drinking water in the surrounding area.

This work was conducted in general accordance with the City of Ottawa’s guidance document as follows:

- City of Ottawa - Hydrogeological and Terrain Analysis Guidelines (March 2021)
- City of Ottawa memo - Carp Road Corridor – Nitrate Impact Assessment Recommendations (September 2016)

The following report describes the Terrain Analysis and associated Sewage System Impact Assessment that was undertaken. This Hydrogeological Assessment and Septic Impact Assessment addresses the following:

- General Site setting information;
- Geological and hydrogeological background;
- Site-specific conditions; and
- Existing and proposed water and wastewater infrastructure (on-site and off-site).

### **1.1 Site Description**

The property is located at 1037 Carp Road. It is described as Plan 5R-4714, Part of Lot 23, Concession 12, Geographic Township of Goulbourn, City of Ottawa. The land in question covers approximately 0.27 ha and is located between Rothbourne Rd and Echowoods Ave. The development area for the proposed works is approximately 0.27 ha.

See Figure 1 for the Site Location Plan for more details.

### **1.2 Existing Conditions and Infrastructure**

The existing site is currently undeveloped and is made up of a gravel lane, trees and bushes. There are no sanitary, water or storm services currently on site. Storm water currently sheet flows to the east corner of the site where it is collected by a rear yard swale system which flows to an existing catchbasin.

Sewer and watermain mapping collected from the topographic survey completed by Fairhall Moffatt & Woodland Ltd. on December 2018 indicates that the following services exist across the property frontages within the adjacent municipal right-of-way:

- 200 mm diameter ductile iron watermain; and

- 150 mm diameter private polyethene sanitary forcemain.

### **1.3 Proposed Development and Statistics**

The proposal is to develop a 2-storey office building. The building will contain 14 office units with a total area of 513 m<sup>2</sup>.

## **2.0 INVESTIGATION**

### **2.1 Site Setting**

At the present time, the existing lot consists of an undeveloped treed area with a gravel entrance on Carp Road. On-site vegetation consists primarily of trees. Based on a review of historical aerial photographs available on GeoOttawa along with field observations, it appears that the subject property has never been developed (earliest photo is 1976) beyond its current use, with the exception of the addition of a gravel entrance onto Carp Road and the associated tree clearing that occurred between 2017 and 2019.

The climate is humid continental with cool winters and warm summers. The 1981-2010 mean annual precipitation is approximately 943.4 mm with 223.5 cm as snow, and the mean daily temperature is 6.4 °C (Environment Canada Climate Normals for Ottawa MacDonald-Cartier Int'l Airport, ON).

### **2.2 Neighbouring Properties and Land Uses**

The Site is bounded to the north, south and west by mixed use/commercial, and residential first density land to the east.

Based on a review of MECP well records, McIntosh Perry's local knowledge of the area, as well as publicly available data from the City of Ottawa's GeoOttawa GIS database, the municipal water supply network services the subject site and all immediately surrounding properties. It is understood that even though a number of properties fronting on Carp Road which were initially serviced by individual drinking water wells have since been connected to the municipal water supply, there may still remain some properties along Carp Road that are serviced by individual drinking water wells. All residential properties immediately east of the subject site along Lloydalex Crescent and further east are of more recent construction (constructed between 2002 and present) and are understood to be fully serviced by the City's municipal infrastructure (i.e. water, storm and sanitary). Additionally, there are no available municipal sanitary sewers in the vicinity of the site along Carp Road and therefore all neighbouring properties along Carp Road are expected to be serviced with private sewage systems. Figures 2 presents the land usage for the surrounding areas, while Figure 3 presents the local topographical and hydrological information.

### **2.3 Hydrology and Hydrogeology**

Ground surface at the Site is generally relatively flat. Regional relief appears to slope to the east-northeast. Ground surface elevation at the Site varies from 122.5-125 m (geodetic). Surface drainage at the Site appears to be largely controlled by sheet flow runoff to the east with a small part of the western edge of the site

currently draining to the roadside which drains south along the east side of Carp Road and eventually discharges into Feedmill Creek. Note that site is near the headwaters of Feedmill Creek, with headwaters of Feedmill Creek originating in a small wetland located just north of Hazeldean Rd and west of Carp Rd. From there it flows to the northeast, under Hwy 417, and then through the Tanger outlet mall property. Feedmill Creek ends where it reaches the Carp River just east of Huntmar Dr. Regional groundwater is interpreted to generally follow the alignment of Feedmill Creek and flow east/northeast, towards Carp River; a review of a publicly available geotechnical report for a nearby proposed residential development at 6171 Hazeldean Road does support this (EXP Services Inc., July 24, 2020). As part of that investigation, three boreholes were advanced in the overburden/ shallow limestone bedrock to intercept the shallow groundwater aquifer and instrumented with piezometers. Static water levels monitoring conducted in the piezometers confirms that local shallow groundwater flow with the overburden/shallow limestone is to the east/north-east.

## 2.4 Water Well Record Review

MP conducted a review of MECP WWIS records within 250 m of the Site. All nineteen wells found within the study area are listed for domestic water supply usage and shown in Figure 4. The MECP Water Well Information System Records are summarized in Table 2-1 below.

**Table 2-1: MECP WWIS Summary (MECP 2021)**

Well ID	Depth (m)	Overburden Material	Depth to Bedrock (m)	Completion Material	Static Water Level (mBGS)	Well Type	Year Completed
1502945	22.9	Gravel, Medium Sand	9.1	Gray Limestone	4.6	Domestic	1956
1502952	17.7	Medium Sand, Boulders	11.6	Sandstone	4.3	Domestic	1960
1502956	24.4	Gravel, Medium Sand	12.5	Limestone	4.6	Domestic	1962
1502957	14.6	Shale, Medium Sand	9.8	Black Limestone	2.4	Domestic	1962
1502958	22.9	Gravel, Medium Sand	14.0	Black Limestone	4.9	Domestic	1963
1503046	20.7	Hardpan	11.6	Limestone	9.1	Domestic	1955
1503049	27.4	Gravel, Boulders, Quicksand	13.7	Limestone	4.9	Domestic	1961
1503100	29	Gravel, Boulders, Medium Sand	11	Blue Lime	12.2	Domestic	1962
1512249	19.5	Clay, Boulders	8.8	Gray Limestone	3.7	Domestic	1972
1513299	21.3	Clay, Stones	13.4	Gray Limestone	4.6	Domestic	1973



Well ID	Depth (m)	Overburden Material	Depth to Bedrock (m)	Completion Material	Static Water Level (mBGS)	Well Type	Year Completed
1513334	14.6	Sand, Gravel, Boulders	7.9	Dark Limestone	1.5	Domestic	1973
1513378	7	Gravel	0	Brown Gravel	1.2	Domestic	1973
1514315	10.1	Sand, Boulders, Gravel	0	Gray Gravel	3	Domestic	1974
1514493	11.9	Gravel, Boulders	0	Gray Gravel	3.7	Domestic	1974
1515281	25.9	Sand, Gravel, Boulders, Hardpan	16.5	Gray Limestone	6.7	Domestic	1976
1515305	29.6	Sand, Gravel, Boulders	10.4	Gray Limestone	4.6	Domestic	1976
1515752	37.5	Sand, Boulders, Stones	12.5	Gray Limestone	3	Domestic	1976
1517181	22.9	Sand, Gravel, Boulders	9.4	Gray Limestone	2.1	Domestic	1979
1535454	83.2	Sand, Boulders	14.6	Gray Limestone	6.2	Domestic	2005

Geological information provided by the well drillers in the WWIS records was generally consistent with Ontario Geological Survey (OGS) data published for the area. Well records described the overburden as sand and gravel and gray limestone as the bedrock. Bedrock was found between 7.9 –16.5 m below ground surface (bgs), with the average of 11.7m bgs (MECP, 2021).

## **2.5 Background Geology and Hydrology**

### *2.5.1 Ontario Geological Survey (OGS) – Surficial Geology*

Geological maps of the area classify the overburden at the Site as glaciofluvial deposits, namely river deposits and delta topset facies. Surficial geology maps of southern Ontario indicate the site is situated between organic deposits to the east and southwest, coarse-textured glaciomarine deposits to the northwest, and Paleozoic bedrock formation to the northeast and southeast. Public geological mapping also identifies three north-south linear features consisting of beach ridges and near shore bars linear features in the immediate vicinity of the site (OGS, 2021).

### *2.5.2 Ontario Geological Survey (OGS) – Bedrock Geology*

Geological maps of the area classify the bedrock under the Site as limestone, dolostone, shale, arkose, and sandstone of the Ottawa Group, Simcoe Group, and/or of the Shadow Lake Formation. (OGS, 2021)

## 3.0 TERRAIN ANALYSIS

### 3.1 On-Site Investigation

As part of a geotechnical investigation, boreholes were advanced via drilling at various locations throughout the Site to assess its geology and subsurface conditions, including properties of the on-site overburden. In total, six boreholes advanced.

Boreholes were advanced using hollow stem augers aided by track-mounted CME 850 drill rig. Boreholes were advanced to a maximum depth of 9.3 m (El. 114.2 m) below the ground level. Boreholes BH20-1 to BH20-4 were advanced to refusal on inferred bedrock, while BH-20-5 and BH20-6 were terminated in the overburden. Soil samples were obtained at 0.75 m intervals in boreholes up to 3.7 m (El. 119.9 m). Below this level, due to the uniformity of the sand layer, samples were obtained at 1.5 m intervals between 3.7 m depth (El. ~ 114.2 m) and 7.6 m depth (El. ~ 116.0 m). Below this level, the sample collection interval was changed back to 0.75 m as the soil stratigraphy changed. The samples were collected using a 51 mm outside diameter split spoon sampler following the Standard Penetration Test (SPT) procedure. Boreholes were backfilled with auger cuttings and restored to the original surface. Refer to Appendix A for draft geotechnical report, including the borehole locations and borehole logs.

All samples were logged as retrieved, and visual description and soil type identification were added to the logs. Subsequently, soil descriptions were confirmed by additional tactile examination of the soils in the laboratory. Laboratory grain-size distribution analysis on representative SPT samples was performed at McIntosh Perry geotechnical lab in accordance with the American Society for Testing Materials (ASTM) test procedures.

### 3.2 Site Evaluation

#### 3.2.1 Overburden Depth

Where boreholes were advanced to refusal, overburden across the site was found to be between 8.6m to 9.4m bgs, with an inferred bedrock elevation between 114.2 m and 115.2m.

#### 3.2.2 Overburden Characterization

In general, the site stratigraphy consists of four layers of shallow topsoil, followed by a thick deposit of sand with different portions of silt and gravel. A till layer composed of silty sand with different portions of gravel and clay was encountered below the sand layer. The till layer is underlain by Inferred bedrock at ~ El 115.0 m. For classification purposes, the soils encountered at this site can be divided into three major zones.

- a) Topsoil
- b) Sand
- c) Till
- d) Inferred Bedrock



The soils encountered during the investigation, together with the field and laboratory test results, are shown on the Record of Borehole sheets included in the Appendix A. Laboratory test results for Particle Size Distribution are also included in Appendix A. Description of the strata encountered are given below.

### 3.2.2.1 Topsoil

A layer of topsoil was encountered in at the existing surface that extend to an approximate depth of 0.9 (El. ~ 122.5 m). The topsoil layer was observed to be dark brown and composes of organic maters including peat, roots, and wood chips. Gravel and cobbles “Limestone” were encountered at the surface in BH20-3 and 20-06. The topsoil was observed to be dry to damp, very loose to loose with SPT ‘N’ value ranges from 2 to 9 blows/300mm.

### 3.2.2.2 Sand

Underlying the topsoil, was a thick layer of sand with traces of silt and gravel, observed to be light brown, dry to moist, and loose to compact. The SPT ‘N’ value ranges from 7 to 30 blows/300mm. The sand layer is followed by a till layer.

Five samples underwent grain size analysis testing, and the layer was observed to contain, on average, 2.0% gravel, 90% sand, 9% silt and clay. In BH20-03 between 4.5 m and 5.5 m depths (El. 118.9 m to 117.9 m), the sand gradation changes to gravelly sand with traces of silt. The grainsize distribution of the soil between these levels changes to contain 22% gravel, 68% sand and 10% fins. Below level 117.9, the soil change back to sand.

A summary of the grain size distribution for this layer is shown in Table 3-1. Test results are shown in Appendix A.

**Table 3-1: Grain Size Distribution of the Sand Layer**

Grain Size	Range (%)
Gravel	0 – 4
Sand	82 – 96
Fines	4 – 15

### 3.2.2.3 Till: Silty Sand, Some Gravel and Clay

A till layer composes of silty sand with different portions of gravel and clay was encountered below the sand at an approximate El. 116.0 m. The till was observed to grey, wet, and very loose to dense, with SPT ‘N’ values ranging from 1 to 54 blows/300mm. Two representative sample underwent grain size analysis testing, and the layer was observed to contain 15% gravel, 47% sand, 14% silt and clay. A summary of the grain size distribution for this layer is shown in Table 3-2.

**Table 3-2: Grain Size Distribution of the Silty Sand Layer in BH20-1**

Grain Size	(%)
Gravel	13 – 17
Sand	51 – 52
Silt	26 – 23
Clay	8 – 11

### 3.2.3 Soil Classification for Private Sanitary Servicing

Comparison of the soil classification for the Unified Soil Classification as provided in the Ministry of Municipal Affairs and Housing (MMAH) Supplementary Standard SB-6: Time and Soil Descriptions, reveals that the main shallow horizon native soil assessed on-site into which any private sewage system would discharge consists of the following:

- SP to SW: well-graded and poorly graded sands, gravelly sands, little or no fines
  - According to Table 2 of SB-6, the SP and SW group of soils have a coefficient of permeability (K) of  $10^{-1}$  to  $10^{-4}$  with a percolation time (T) of 2 to 12 min/cm. This soil type has a medium permeability, and is deemed acceptable as the native receiving soil for a proposed Class 4 sewage system.

Based on the above-noted soil classifications, it is proposed the development be serviced with a Class 4 sewage system with a leaching bed constructed to discharge within the native sand deposits present throughout the Site.

### 3.2.4 Groundwater

Groundwater was observed in five open boreholes. At the time of investigation on October 14 and 15, 2020, the depth of the groundwater ranged between 5.8 m (El. 117.8 m) to 6.1 m (El. 117.2 m). The depth and level of groundwater in five boreholes are summarized in Table 3-3. The groundwater level may be expected to fluctuate due to seasonal changes.

**Table 3-3: Groundwater Level Readings in Open Boreholes**

Borehole	Measuring Date	Surface El. (m)	Groundwater Depth (m bgs)	Water Table El. (m)
BH20-01	2020-10-14	123.6	5.8	117.8
BH20-02	2020-10-14	124.1	5.8	118.3
BH20-03	2020-10-14	123.4	5.7	117.7
BH20-04	2020-10-15	123.5	5.8	117.7
BH20-05	2020-10-15	123.3	6.1	117.2

Further to this, the site was instrumented with three monitoring wells via a drilling program overseen by McIntosh Perry on October 12, 2022 in order to obtain precise groundwater measurements. The monitoring

wells were advanced and screened at a depth sufficient to intercept the shallow groundwater table. The relative depth and elevation of groundwater in the three monitoring wells are summarized in Table 3-4 and Figure 5. The measured groundwater levels confirm that the local shallow groundwater flow is N-E, which is in agreement with regional topography/hydrology patterns, as well as findings of available background hydrogeological reports for neighbouring sites. The groundwater levels may be expected to fluctuate due to seasonal changes.

**Table 3-4: Groundwater Level Readings in Monitoring Wells**

Monitoring Well ID	Measuring Date	Top of Casing (m)	Groundwater Depth (m bTOC)	Water Table El. (m)
BH22-1MW	2020-11-07	99.26	5.94	93.32
BH22-2MW	2020-11-07	99.555	6.17	93.385
BH22-3MW	2020-11-07	100.00	6.42	93.58

### 3.2.5 Bedrock

As previously discussed, on-site bedrock is generally characterized as limestone, dolostone, shale, arkose, and sandstone of the Ottawa Group, Simcoe Group, and/or of the Shadow Lake Formation (OGS 2021), which is supported by well records that list the bedrock as either “sandstone” or “limestone”. Based on OGS karst mapping (OGS 2021), the subject is within a potential karst area, with inferred karst areas identified approximately 200 m and 400 m further east and south-west, respectively. No observations of the bedrock were made during the site investigation and given the depth of overburden on the subject site, this was does not identified as significant concern for the proposed development.

### 3.2.6 Recharge and Discharge Areas

Based on a review of topographic data, geological maps, and a site visit, it is our interpretation that the Site is predominantly a groundwater recharge zone. The Site is located on a ridge and appears to be generally well drained. It should be noted that the site is situated atop a north-south ridge that is approximately 3 meters higher than land immediately further east.

### 3.2.7 Hydrogeologically Sensitive Areas

Based on McIntosh Perry’s test pitting program and available well records in the vicinity, the Site has soil thicknesses generally exceeding 8.5 m and there were no observed areas of bedrock outcrop or karst conditions on or near the site. The proposed development area appears to be well drained and there were no areas of groundwater upwelling or significant discharge noted during fieldwork. The Site is therefore not considered to be in hydrogeologically sensitive area.

## 4.0 SEPTIC IMPACT ASSESSMENT

As part of the development application process, the City of Ottawa requires that a septic impact assessment be completed as per the City’s Hydrogeological and Terrain Analysis Guidelines. The City’s guidelines generally

follow the MECP's Procedure D-5-4 (Technical Guideline for Individual On-site Sewage Systems: Water Quality Impact Risk Assessment) outlines the following steps to be completed as part of a septic impact assessment:

- Step 1 – Lot Size Consideration
- Step 2 – System Isolation Consideration
- Step 3 – Contaminant Attenuation Considerations

There may exist circumstances however in which the three-step assessment process does not apply when determining the "Reasonable Use" of the groundwater at the Director or approval agency's discretion as outlined in Section 5.3a of Guideline D-5-4 (Fundamental Considerations). In this case, it is being proposed that the local review/approval agency consider that the local water supply aquifer on-site and downgradient (from a groundwater flow perspective) is not currently (and is not expected to ever be) used as a water supply aquifer given the availability of municipal drinking water service in the area and there are no sensitive hydrogeological receptors downgradient within the radius of influence of the site, therefore typical septic impact assessment targets (i.e. nitrate dilution targets) do not need to be assessed.

It should be noted that it is expected that there could remain a few private drinking water supply wells in use along Carp Road, but that from a shallow and regional groundwater flow perspective, it is expected that along Carp Road, only the properties immediately north and south of the subject site (i.e. 1027 and 1031 Carp Road) would be reasonably expected to potentially be impacted by subsurface discharge of sewage effluent on the subject site. It was confirmed via telephone interviews conducted with the landowners of both of these properties in August of 2021 that they are both currently serviced by the municipal water supply. It is noted that the City of Ottawa did confirm that within 500m of the site only 3 lots were not connected to the municipal services: 1044 Carp Road, 1016 Carp Road, and the lot directly to the SE of 1016 Carp Road. Since 1044 Carp Road is not developed and must connect to the municipal water if it is developed in the future, this site is not a concern. The other two lots are located adjacent to each other on the SW corner of the Carp Road and Rothbourne Road and appear to be used as an outdoor landscaping material depot. It is unclear if the facility is currently serviced by a groundwater supply well, but a review of Google StreetView suggest that the single outbuilding may not be connected to indoor plumbing or a typical Class 4 sewage system due to the presence of an outdoor portable toilet.

Overall, the primary concern with respect to septic impact assessment for the proposed development is associated with subsurface flow of sewage effluent discharge on the subject site towards the east, and therefore with the residential properties located east of the subject site (i.e. along Lloyalex Crescent and further east). To that end, all the residential properties immediately east of the subject site along Lloyalex Crescent and further east are of more recent construction (constructed between 2002 and present) and are known to be fully serviced by the City's municipal infrastructure.

Based on the above-noted discussion, the proposed development is not expected to affect any existing or potential drinking water supply aquifer and therefore it is recommended that the review agency accept that a septic impact assessment is not required due to "Reasonable Use" considerations.

## 5.0 RECOMMENDATIONS

### 5.1 Wastewater Servicing

#### Private Sewage Systems

- Approval for on-site septic treatment will be governed by the OBC as it is understood that the Daily Design Flow proposed commercial office building will be approximately 6,720 litres per day (i.e. less than 10,000 litres per day).
- It is recommended that the proposed commercial development be serviced with Class 4 sewage systems with leaching beds constructed to discharge within the native sand as is present throughout the Site.
- Any septic systems must be constructed with all appropriate setbacks, treatment units and stipulations as per applicable Ontario Regulations.

#### Servicing Layout

- The proposed development and associated new Class 4 sewage system should follow the layout included in the Site Plan application.

#### Maintaining Groundwater Recharge

- Given that the Site lies within an area identified as high recharge within the Carp River Subwatershed Study, stormwater criteria for the development of the site are based on the pre-consultation notes provided by the City of Ottawa staff on November 18<sup>th</sup>, 2019, where post-development drainage rates must meet pre-development drainage conditions. Existing drainage patterns for the site are being maintained in accordance with the City's criteria. Best management practices are provided in the proposed development plans with regards to the on-site infiltration. The swale system and storage area will provide an opportunity for detention and infiltration of stormwater. In addition, the proposed on-site septic system has been designed for 6,270 L/d, allowing for additional groundwater recharge through infiltration within the sewage system's leaching bed.

## 6.0 LIMITATIONS

This report has been prepared and the work referred to in this report has been undertaken by McIntosh Perry Consulting Engineers Ltd. for Jim Bell Architecture Design Inc. It is intended for the sole and exclusive use of Jim Bell Architecture Design Inc., their affiliated companies and partners and their respective insurers, agents, employees, advisors, and reviewers. The report may not be relied upon by any other person or entity without the express written consent (Reliance Letter) of McIntosh Perry Consulting Engineers Ltd.

Any use which a third party makes of this report, or any reliance on decisions made based on it, without a reliance letter are the responsibility of such third parties. McIntosh Perry Consulting Engineers Ltd. accept no responsibility for damages, if any, suffered by any third party as a result of decisions made or actions based on this report.

The investigation undertaken by McIntosh Perry Consulting Engineers Ltd. with respect to this report and any conclusions or recommendations made in this report reflect McIntosh Perry Consulting Engineers Ltd. judgment based on the Site conditions observed at the time of the site inspection on the date(s) set out in this report and on information available at the time of the preparation of this report.

This report has been prepared for specific application to this site and it is based, in part, upon visual observation of the Site, subsurface investigation at discrete locations and depths, and specific analysis of specific chemical parameters and materials during a specific time interval, all as described in this report. Unless otherwise stated, the findings cannot be extended to previous or future Site conditions, portions of the Site which were unavailable for direct investigation, subsurface locations which were not investigated directly, or chemical parameters, materials or analysis which were not addressed. Substances other than those addressed by the investigation described in this report may exist within the Site, substances addressed by the investigation may exist in areas of the Site not investigated and concentrations of substances addressed which are different than those reported may exist in areas other than the locations from which samples were taken.

If site conditions or applicable standards change or if any additional information becomes available at a future date, modifications to the findings, conclusions and recommendations in this report may be necessary.

We trust that this information is satisfactory for your present requirements. Should you have any questions or require additional information, please do not hesitate to contact the undersigned.

Respectfully submitted,

McIntosh Perry Consulting Engineers Ltd.



Patrick Leblanc, P.Eng.  
Practice Area Lead (Environmental Engineer)  
(613) 714-4586  
p.leblanc@mcintoshperry.com

## **7.0 REFERENCES**

City of Ottawa, March 2021. Hydrogeological and Terrain Analysis Guidelines.

EXP Services Inc, July 24, 2020. Geotechnical Investigation, Proposed Residential Development – 6171 Hazeldean Road, Ottawa, ON (Project No. OTT-00258780-B0).

OGS Earth, 2021. Ontario Ministry of Northern Development, Mines and Forestry, - Ontario Geological Survey Earth – for Google Earth. Overburden classification data for Eastern Ontario.

OGS Earth, 2021. Ontario Ministry of Northern Development, Mines and Forestry, - Ontario Geological Survey Earth – for Google Earth. Bedrock classification data for Eastern Ontario.

McIntosh Perry, November 2020. Geotechnical Report – Office Complex 1037, Carp Road (Project No. CP-19-0125).

MOE, 1996. Procedure D-5-4 Individual On-Site Sewage Systems: Water Quality Impact Risk Assessment.

# FIGURES



C:\Users\stunum\McIntosh Perry\GIS - Documents\Projects\2019\CCO\CCO-19-0125\_Bakim Land and Development\Map\LandDevelopment\OptionD\CCO-19-0125\_LandDevelopment\_OptionD.aprx

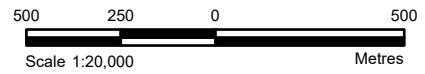

**LEGEND**

-  Site Location
-  Watercourse
-  Local Road
-  Waterbody
-  Major Road
-  Wooded Area

**REFERENCE**

GIS data provided by the Ontario Ministry of Natural Resources and Forestry, 2021.

CLIENT:	<b>JIM BELL ARCHITECTS</b>	
PROJECT:	<b>SEPTIC IMPACT ASSESSMENT 1037 CARP ROAD, OTTAWA, ON</b>	
TITLE:	<b>SITE LOCATION PLAN</b>	
<b>McINTOSH PERRY</b> 115 Walgreen Road, RR3, Carp, ON K0A1L0 Tel: 613-836-2184 Fax: 613-836-3742 www.mcintoshperry.com	PROJECT NO: CCO-19-0125	FIGURE:
	Date	Aug., 18, 2021
	Checked By	PL
		<b>1</b>

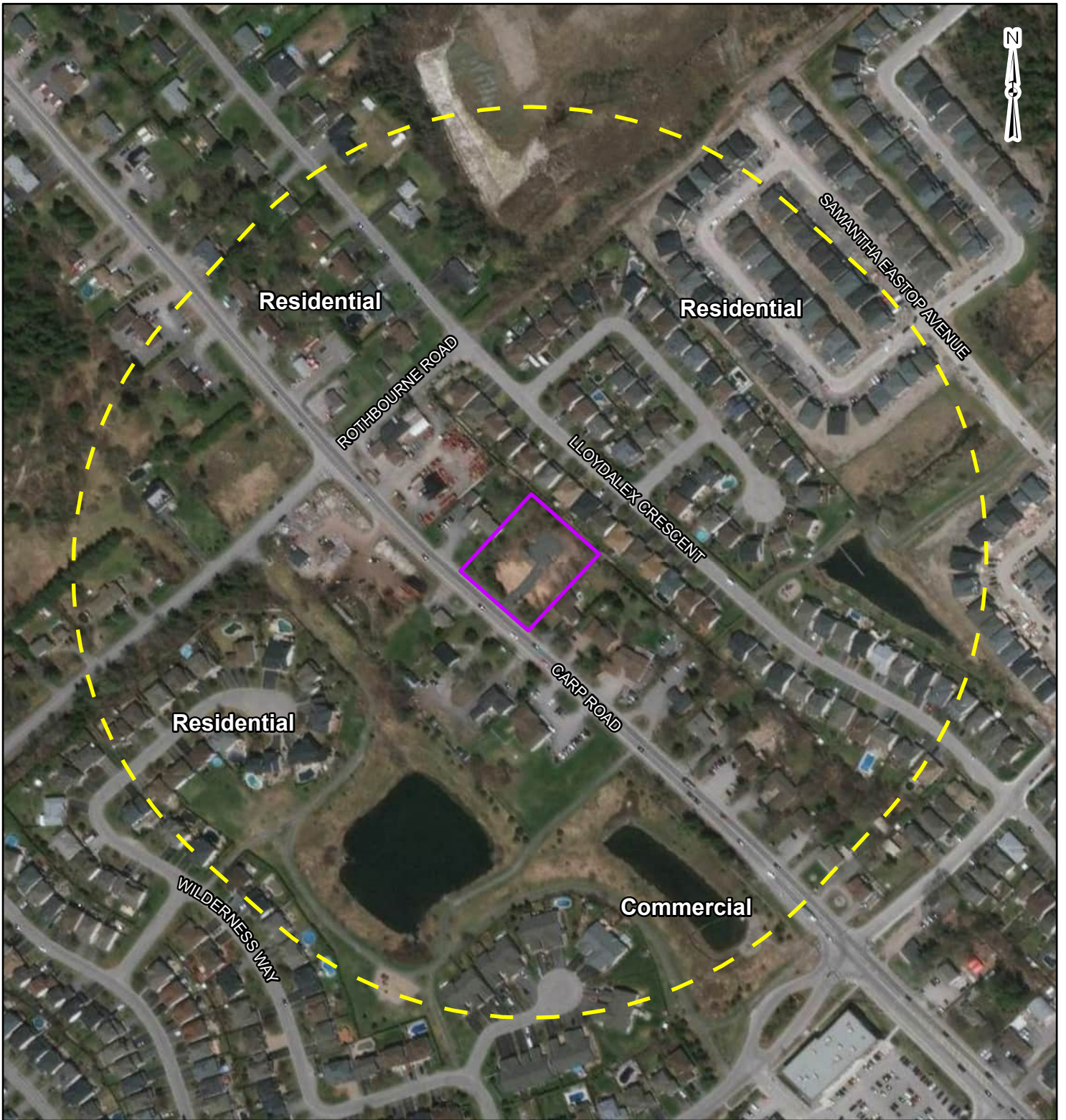

**LEGEND**

- Approximate Site Boundary
- 250m Buffer

**REFERENCE**

GIS data provided by the Ontario Ministry of Natural Resources and Forestry, 2020.

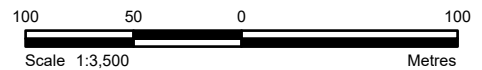

CLIENT:	<b>JIM BELL ARCHITECTS</b>		
PROJECT:	<b>SEPTIC IMPACT ASSESSMENT 1037 CARP ROAD, STITTSVILLE</b>		
TITLE:	<b>STUDY AREA AND SURROUNDING LAND USE</b>		
<b>McINTOSH PERRY</b> 115 Walgreen Road, RR3, Carp, ON K0A1L0 Tel: 613-836-2184 Fax: 613-836-3742 www.mcintoshperry.com	PROJECT NO:	CCO-19-0125	FIGURE:
	Date	Oct., 4 , 2021	<b>2</b>
	GIS	EU	
Checked By	P L		



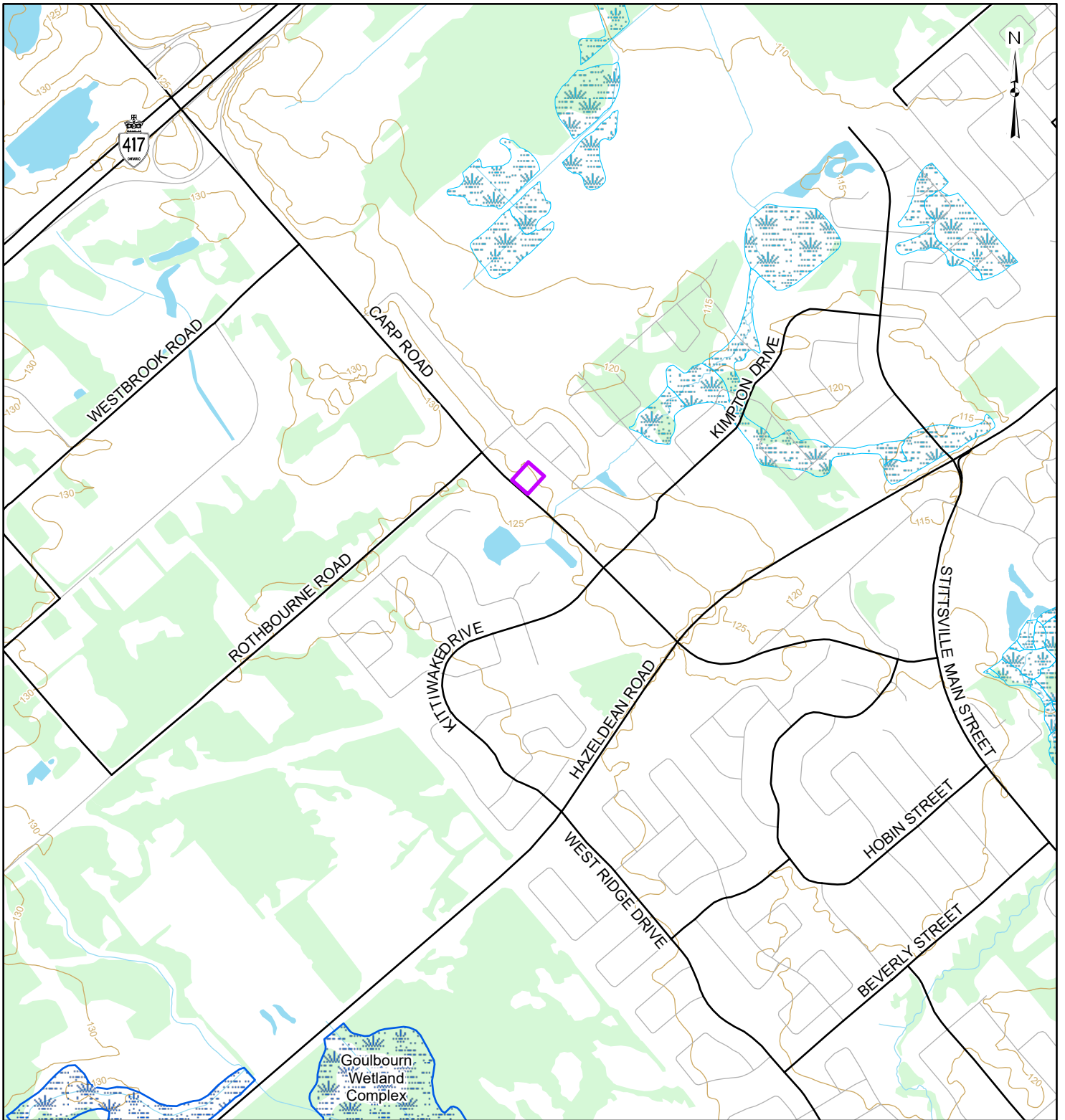

**LEGEND**

- Approximate Site Boundary
- Contour (masl)
- Local Road
- Major Road
- Watercourse
- Waterbody
- Provincially Significant Wetland
- Unevaluated Wetland
- Wooded Area

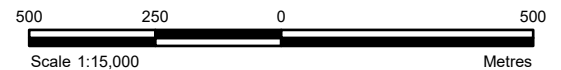

**REFERENCE**

GIS data provided by the Ontario Ministry of Natural Resources and Forestry, 2020.

<b>CLIENT:</b>	<b>JIM BELL ARCHITECTS</b>	
<b>PROJECT:</b>	<b>SEPTIC IMPACT ASSESSMENT 1037 CARP ROAD, STITTSVILLE</b>	
<b>TITLE:</b>	<b>DRAINAGE AND TOPOGRAPHY</b>	
<b>PROJECT NO:</b>	CCO-19-0125	<b>FIGURE:</b>
<b>Date</b>	Oct.4 , 2021	<b>3</b>
<b>GIS</b>	EU	
<b>Checked By</b>	P L	

**McINTOSH PERRY**  
 115 Walgreen Road, RR3, Carp, ON K0A1L0  
 Tel: 613-836-2184 Fax: 613-836-3742  
 www.mcintoshperry.com

C:\Users\stunum\McIntosh Perry\GIS - Documents\Projects\2019\CCO\CCO-19-0125\_Bakim Concrete Inc. - 1037 Carp Road\Map\Environmental\MECP Well Record\CCO-19-0125\_01\_MECPWWellRecord.aprx

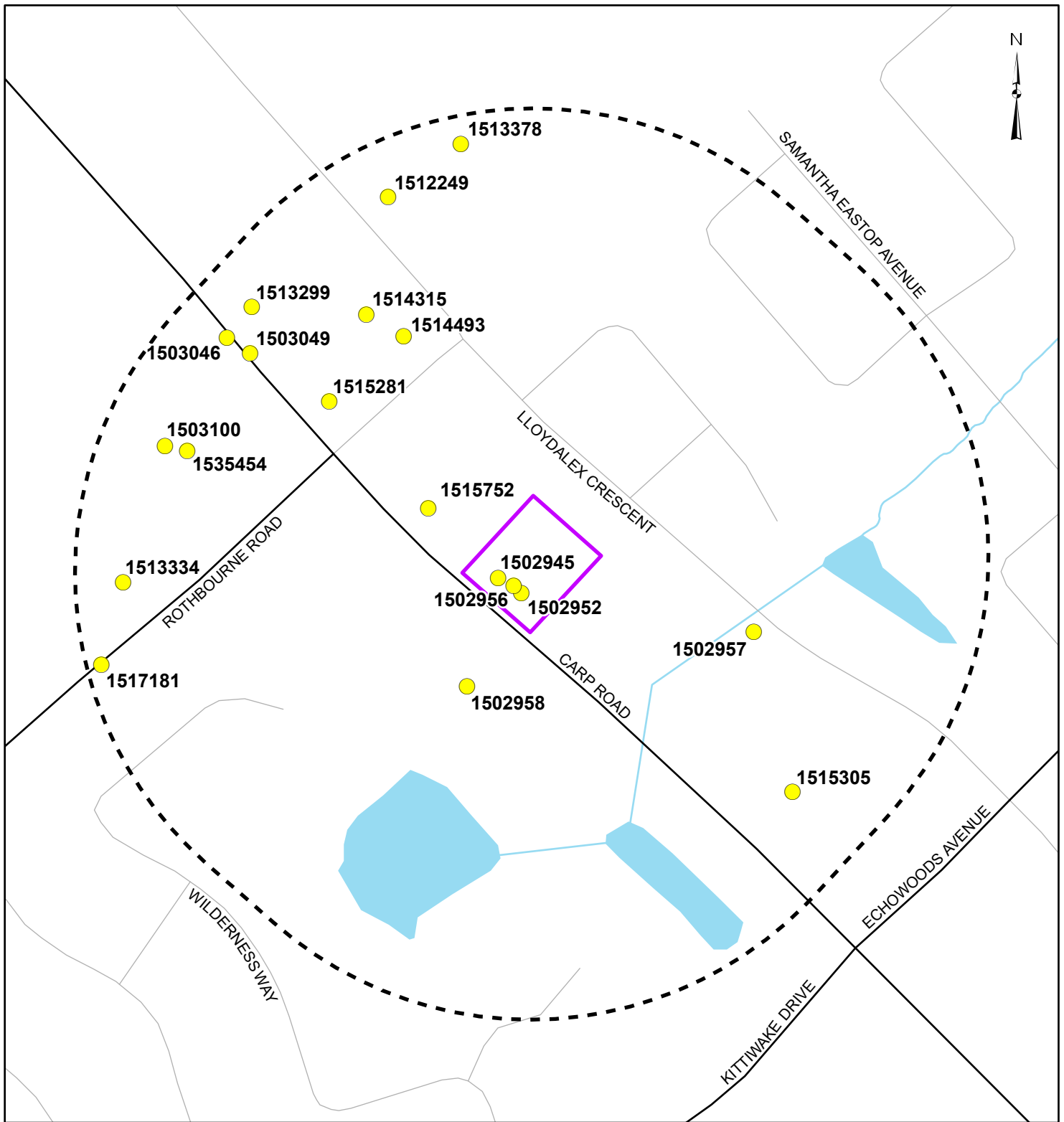

**LEGEND**

- Approximate Site Boundary
- 250m Buffer
- MECP Well Location
- Local Road
- Major Road
- ~ Waterbody
- ~ Watercourse

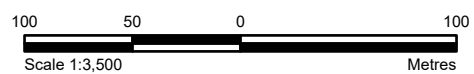

**REFERENCE**



GIS data provided by the Ontario Ministry of Natural Resources and Forestry, 2021.

<b>CLIENT:</b>	<b>JIM BELL ARCHITECTS</b>	
<b>PROJECT:</b>	<b>SEPTIC IMPACT ASSESSMENT 1037 CARP ROAD, STITTSVILLE, ON</b>	
<b>TITLE:</b>	<b>MECP WELL RECORD SUMMARY</b>	
	<b>PROJECT NO: CCO-19-0125</b>	<b>FIGURE:</b>
Date	Sep., 03, 2021	<b>4</b>
GIS	EU	
Checked By	PL	

**McINTOSH PERRY**  
 115 Walgreen Road, RR3, Carp, ON K0A1L0  
 Tel: 613-836-2184 Fax: 613-836-3742  
 www.mcintoshperry.com





**LEGEND:**  
 SHALLOW GROUNDWATER FLOW DIRECTION  
 SHALLOW GROUNDWATER COUNTOURS (NOV.7.2022)

No.	Revision/Issue	Date

**McINTOSH PERRY**  
 115 Walgreen Road, RR 3  
 Carp, ON K0A 1L0  
 Tel: 613-836-2184 Fax: 613-836-3742  
 www.mcintoshperry.com

Stamp:	Stamp:

Client:  
**JIM BELL ARCHITECTS**

Project:  
**SEPTIC IMPACT ASSESSMENT**  
 1037 CARP ROAD, STITTSVILLE, ON

Drawing Title:  
**SHALLOW GROUNDWATER CONTOURS AND FLOW DIRECTION**

Scale: 1:300	Project Number: 0CP-19-0125
Drawn by: PL	Drawing Number: <b>SIA - 5</b>
Checked By: PL	
Designed By: PL	Date: NOV/25/2022

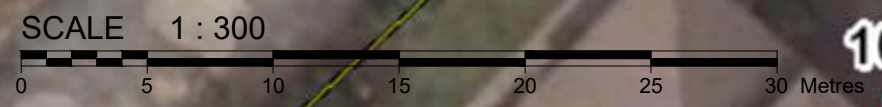

FILENAME: U:\OTAWA\01 - Project - Proposa\2019 Jobs\OCP-Projects\OCP-19-0125 Jim Bell Office Building\_1037 Carp Road\Civil\2 - Drawings\Sewage System\OCP-19-0125\_Design with SDO Nov.22.2022.dwg  
 LAST PLOTTED: Friday, November 25, 2022 10:51:52 AM  
 PLOTTER: HP DesignJet T1100PS



# APPENDIX A – GEOTECHNICAL REPORT

# OFFICE COMPLEX\_1037 CARP ROAD GEOTECHNICAL REPORT

Project No.: CP-19-0125

Prepared for:

Jim Bell Architectural Design Inc.  
26 Bert G. Argue Dr,  
Stittsville, ON K2S 1X9

Prepared by:

McIntosh Perry  
104-215 Menten Place  
Ottawa, ON K2H 9C1

November 2020

## TABLE OF CONTENTS

1.0	INTRODUCTION .....	1
2.0	SITE DESCRIPTION .....	1
3.0	PROJECT UNDERSTANDING.....	2
4.0	FIELD PROCEDURES.....	2
5.0	IDENTIFICATION AND TEST PROCEDURES .....	2
6.0	SITE GEOLOGY AND SUBSURFACE CONDITIONS.....	3
6.1	Site Geology.....	3
6.2	Subsurface Conditions.....	3
6.2.1	Topsoil .....	3
6.2.2	Sand.....	4
6.2.3	Till: Silty Sand, Some Gravel and Clay .....	4
6.3	Groundwater .....	4
6.4	Chemical Analysis .....	5
7.0	DISCUSSIONS AND RECOMMENDATIONS .....	5
7.1	General.....	5
7.2	Overview .....	6
7.3	Foundations.....	7
7.3.1	Foundation Excavation.....	7
7.3.2	Shallow Foundations.....	8
7.4	Seismic Site Classification.....	9
7.4.1	Liquefaction Potential .....	10
7.5	Engineered Fill .....	10
7.6	Slabs-on-Grade.....	10
7.7	Lateral Earth Pressure.....	11
7.8	Sidewalks and Hard Surfacing.....	11
7.9	Cement Type and Corrosion Potential .....	12
8.0	PAVEMENT STRUCTURE .....	12
9.0	CONSTRUCTION CONSIDERATIONS.....	13



---

10.0	GROUNDWATER SEEPAGE.....	14
11.0	SITE SERVICES.....	14
12.0	CLOSURE.....	15

APPENDICES

Appendix A – Limitations of Report
Appendix B – Figures
Appendix C – Borehole Records
Appendix D – Laboratory Test Results
Appendix E – Seismic Hazard Calculation
Appendix F – Relevant Standards

GEOTECHNICAL INVESTIGATION and  
FOUNDATION DESIGN AND RECOMMENDATION REPORT  
Proposed Office Complex at 1037 Carp Road, Stittsville, Ontario

## 1.0 INTRODUCTION

This report presents the factual findings obtained from a geotechnical investigation performed at the above-mentioned site for a proposed two-storey office complex with parking lot and no basement. The fieldwork was carried out on October 14, 2020, to October 15, 2020, and comprised of five foundation boreholes to a maximum depth of 9.3 m, and one pavement borehole in the parking lot to a depth of 2.1m below existing surface.

The purpose of the investigation was to explore the subsurface conditions at this site and to provide borehole location plans, a record of borehole logs, and laboratory test results. This report provides anticipated geotechnical conditions influencing the design and construction of the proposed two-storey office buildings and the parking lot. The report also includes recommendations for the foundation and parking lot pavement design. Recommendations are offered based on the authors' interpretation of the subsurface investigation and test results. The readers are referred to Appendix A, Limitations of Report, which is an integral part of this document.

The investigation was performed at the request of the Jim Bell Architectural Design Inc.

## 2.0 SITE DESCRIPTION

The site is located in a mixed residential and commercial area. It is bounded by residential dwellings with chain link fence from the northeast side, and commercial properties at the northwest and southeast. The site is accessible from Carp Road at the southwest side through a gravel driveway. A drainage ditch is bounded the site along Carp Road and a corrugated steel pipe side culvert connects the ditch under the gravel driveway.

At the time of the investigation the lot was heavily vegetated with mature trees, dead logs, and bushes and the ground is covered with limestone, wood chips, roots, and tree leaves. Trees and bushes were partially cleared from the middle of the lot to provide access to the lot. The property and borehole locations are shown in Figure 2, in Appendix B.

### 3.0 PROJECT UNDERSTANDING

It is understood that the proposed office complex includes three buildings with 1750, 3500, and 3500 square feet of footprint area which may be constructed through separate phases. All three phases are proposed as two storey buildings without a basement. A total number of 46 parking spots are provisioned.

### 4.0 FIELD PROCEDURES

The staff of McIntosh Perry Consulting Engineers (McIntosh Perry) visited the site before the drilling investigation to mark out the proposed borehole locations to obtain utility clearance to identify the location of underground infrastructures. Utility clearance was carried out by Underground Service Locators (USL-1) on behalf of McIntosh Perry. Public and private utility authorities were informed, and all utility clearance documents were obtained before the commencement of drilling work.

The equipment used for drilling was owned and operated by CCC Geotechnical & Environmental Drilling Ltd. of Ottawa, Ontario. Boreholes were advanced using hollow stem augers aided by track-mounted CME 850 drill rig. Boreholes were advanced to a maximum depth of 9.3 m (E. 114.2 m) below the ground level. Soil samples were obtained at 0.75 m intervals in boreholes up to 3.7 m (E. 119.9 m). Below this level, due to the uniformity of the sand layer, samples were obtained at 1.5 m intervals between 3.7 m depth (E. ~ 114.2 m) and 7.6 m depth (E. ~ 116.0 m). Below this level, the sample collection interval was changed back to 0.75 m as the soil stratigraphy changed. The samples were collected using a 51 mm outside diameter split spoon sampler following the Standard Penetration Test (SPT) procedure. Boreholes were backfilled with auger cuttings and restored to the original surface. Borehole locations are shown in Figure 2, included in Appendix B.

### 5.0 IDENTIFICATION AND TEST PROCEDURES

All samples were logged as retrieved, and visual description and soil type identification were added to the logs. Subsequently, soil descriptions were confirmed by additional tactile examination of the soils in the laboratory. Laboratory grain-size distribution analysis on representative SPT samples was performed at McIntosh Perry geotechnical lab in accordance with the American Society for Testing Materials (ASTM) test procedures.

Parcel Laboratories Ltd., in Ottawa, carried out chemical tests on two representative soil samples to determine the soil corrosivity characteristics.

Test procedures are listed below;

ASTM C136 – Sieve Analysis of Fine and Coarse Aggregates (LS-602)

LS-702 – Determination of Particle Size Analysis of Soils

ASTM D1586 – Standard Penetration Test (SPT) and Split-Barrel Sampling of Soils

The rest of the soil samples recovered will be stored in McIntosh Perry storage facility for a period of one month after submission of the final report. Samples will be disposed of after this time unless otherwise requested in writing by the Client.

## 6.0 SITE GEOLOGY AND SUBSURFACE CONDITIONS

### 6.1 Site Geology

Based on published physiography maps of the area (Ontario Geological Survey), the site is located within the boundary region between Ottawa Valley Clay Plains and Smiths Falls Limestone Plain. Surficial geology maps of southern Ontario indicate the site is situated on glaciofluvial deposits, between organic deposits to the east and southwest, coarse-textured glaciomarine deposits to the northwest, and Paleozoic bedrock formation to the northeast and southeast. The glaciofluvial deposits in this region are predominantly river deposits, gravel, sand, silt and clay, and delta topset facies.

### 6.2 Subsurface Conditions

In general, the site stratigraphy consists of four layers of shallow topsoil, followed by a thick deposit of sand with different portions of silt and gravel. A till layer composes of silty sand with different portions of gravel and clay was encountered below the sand layer. It was inferred the till layer is underlain by bedrock at ~ E 115.0 m. For classification purposes, the soils encountered at this site can be divided into four distinctive strata.

- a) Topsoil
- b) Sand
- c) Till
- d) Inferred Bedrock

The soils encountered during the investigation, together with the field and laboratory test results, are shown on the Record of Borehole sheets included in Appendix C. Laboratory test results are included in Appendix D. Description of the strata encountered are given below.

#### 6.2.1 Topsoil

A layer of topsoil was encountered at the existing surface that extends to an approximate depth of 0.9 (E. ~ 122.5 m). The topsoil layer was observed to be dark brown and composes of organic matters including peat, roots, and wood chips. Gravel and cobbles "Limestone" were encountered at the surface in BH20-3 and 20-06. The topsoil was observed to be dry to damp, very loose to loose with SPT 'N' value ranges from 2 to 9 blows/300mm.

### 6.2.2 Sand

Underlying the topsoil, was a thick layer of sand with traces of silt and gravel, observed to be light brown, dry to moist, and loose to compact. The SPT 'N' value ranges from 7 to 30 blows/300mm. The sand layer is followed by a till layer.

Five samples underwent grain size analysis testing, and the layer was observed to contain, on average, 2.0% gravel, 90% sand, 9% silt and clay. In BH20-03 between 4.5 m and 5.5 m depths (El. 118.9 m to 117.9 m), the sand gradation changes to gravelly sand with traces of silt. The grainsize distribution of the soil between these levels changes to contain 22% gravel, 68% sand and 10% fins. Below level 117.9, the soil change back to sand.

A summary of the grain size distribution for this layer is shown in Table 6-1. Test results are shown in Figures 4 and 5, included in Appendix B.

Table 6-1: Grain Size Distribution of the Sand Layer

Grain Size	Range (%)
Gravel	0 – 4
Sand	82 – 96
Fines	4 – 15

### 6.2.3 Till: Silty Sand, Some Gravel and Clay

A till layer composes of silty sand with different portions of gravel and clay was encountered below the sand at an approximate El. 116.0 m. The till was observed grey, wet, and very loose to dense, with SPT 'N' values ranging from 1 to 54 blows/300mm. Two representative sample underwent grain size analysis testing, and the layer was observed to contain 15% gravel, 47% sand, 14% silt and clay. A summary of the grain size distribution for this layer is shown in Table 6-2.

Table 6-2: Grain Size Distribution of the Silty Sand Layer in BH20-1

Grain Size	(%)
Gravel	13 – 17
Sand	51 – 52
Silt	26 – 23
Clay	8 – 11

## 6.3 Groundwater

Groundwater was observed in five open boreholes. At the time of investigation, October 14 and 15, 2020, the depth of the groundwater ranged between 5.8 m (El. 117.8 m) to 6.1 m (El. 117.2 m). The depth and level of

groundwater in five boreholes are summarized in Table 6-3. The groundwater level may be expected to fluctuate due to seasonal changes.

Table 6-3: Groundwater Level Readings in Open Boreholes

Borehole	Measuring Date	Surface El. (m)	Groundwater Depth (m)	Water Table El. (m)
BH20-01	2020-10-14	123.6	5.8	117.8
BH20-02	2020-10-14	124.1	5.8	118.3
BH20-03	2020-10-14	123.4	5.7	117.7
BH20-04	2020-10-15	123.5	5.8	117.7
BH20-05	2020-10-15	123.3	6.1	117.2

## 6.4 Chemical Analysis

The chemical test results conducted by Paracel Laboratories in Ottawa, Ontario, to determine the resistivity, pH, sulphate and chloride content of two representative soil samples are shown in Table 6-4 below. Chemical test results are included in Appendix D and summarized in below table.

Table 6-4: Soil Chemical Analysis Results

Borehole	Sample	Depth / El. (m)	pH	Sulphate (%)	Chloride (%)	Resistivity (Ohm-m)
BH20-01	SS-03	1.5 ~ 2.1	8.06	<0.0005	0.0009	126
BH20-03	SS-03	1.5 ~ 2.1	7.92	<0.0005	0.0007	92

## 7.0 DISCUSSIONS AND RECOMMENDATIONS

### 7.1 General

This section of the report provides engineering recommendations on the geotechnical design aspect of the project based on the project requirements and our interpretation of the subsurface soil information. The recommendations presented herein are subject to the limitations noted in Appendix A “Limitations of Report” which forms an integral part of this document.

The foundation engineering recommendations presented in this section have been developed following Part 4 of the 2015 National Building Code of Canada (NBCC) and 2012 Ontario Building Code (OBC) extending the Limit State Design approach.

## 7.2 Overview

It is understood that the proposed office complex consists of two-storey structures without a basement. It is also understood that the finished floor elevation for the proposed development will be approximately at E. 125.5 m to 126.0 m.

For the current project, the following list summarizes some key geotechnical facts that were considered in the suggested geotechnical recommendations:

- Topsoil is not a competent engineering material for construction and can undergo significant volume changes that can adversely affect the integrity of the structure, utilities as well as the parking lot pavement. Therefore, any loose materials, topsoil and organic matters need to be cleared from the footprint of the proposed buildings, the parking lot, and any form of hard landscaping.
- Considering the order of structural loads expected at the foundation level, the provision of conventional spread and strip footings is adequate. Footings are expected to be buried to resist overturning, sliding, and also to provide protection against frost action.
- The proposed structure can be designed using a seismic Site Class D provided that the boundary zones of the shear walls and all column loads are extended to and supported on the compact to dense sand layer by spread footings.
- Excavation for foundations will be advanced below the existing ground level through the topsoil and sand deposits. The sand deposit can exhibit collapsing behavior upon excavation. The sides of excavation shall be sloped from its bottom at a minimum gradient of 3H:1V. For trench excavation that is deeper than 1.2 m or a worker is required to enter, excavation shall be carried out within trench boxes, which is fully braced to resist lateral earth pressure.
- In addition, the footprint of the proposed development is adjacent to occupied residential and commercial buildings on the south, north and east, and Carp Road at west side. If excavations depth near adjacent building extend below their foundation depth, shoring system, such as sheet piles is required.
- The surface and groundwater inflow to the excavation can be handled by pumping from well-filtered sumps established on the floor of the excavation. The actual inflow into the excavation will depend on many factors including, but not limited to, the contractor's schedule, the rate of excavation, the size of the excavation, and the time of the year at which the excavation is to occur. Based on the encountered stratigraphy and the amount of groundwater intake, application for PTTW will be required only if excavations extend below groundwater level (E. ~ 119.0 m). If more precise information on potential

groundwater seepage is needed, a separate permeability test can be carried in the existing monitoring well as part of a separate scope of work.

### 7.3 Foundations

In general, the subsurface conditions in the area of the proposed low-rise building consists of a thick layer of sand that is followed by a till layer composed of silty sand with some gravel and clay layer. The depth of the bedrock is approximately at 8.6 to 9.4 m (E. ~ 114.8 m) from the existing ground surface.

It is understood that the level of finished floor for the new proposed buildings is approximately at 125.5 m to 126.0 m. Based on the freezing index for the Southern Ontario Region provided for this site, the frost penetration depth is expected at 1.8 m below the ground surface. Frost depth can be reduced to 1.5 m below finished surface for those buildings constantly heated during winter season. The underside of the foundations will likely be at an elevation of 123.7 to 124.2 m. Based on these elevations, grade raise on engineered fill is required. Granular A conforming to OPSS 1010 compacted to minimum 100% Standard Proctor Maximum Dry Density (SPMDD) shall be used for grade raise below the footings.

The SPT field test results, 'N' values within the expected depth and influence zone (twice of the footing width) of a spread footing range between 4 to 24 blows/300mm. The sand layer can be classified according to the Canadian Foundation Engineering Manual (CFEM) (2006) as loose to compacted sand. The estimated average angle of internal friction ( $\phi'$ ) within the stress influence zone below the footing is approximately 28°. The sand layer is a competent layer and can provide suitable support to the expected loads from the structure.

#### 7.3.1 Foundation Excavation

Excavation for the construction of the foundation will proceed through the native topsoil and sand deposits. Excavating of overburden soil shall be performed using conventional hydraulic excavating equipment. The Occupational Health and Safety Act (OHSA) of Ontario indicated that side slopes in the sand above the water table could be classified as Type 3 soil and below the water table as Type 4 soil and sloped no steeper than 3H:1V or be shored. If space restrictions exist, the excavations of depth greater than 1.2 m can be carried out within trench boxes, which is fully braced to resist lateral earth pressure.

In order to limit the amount of differential settlement, all footings shall be bearing on similar subgrade conditions. The subgrade shall be cleaned from all deleterious material and to be proof rolled to reduce loose spots and to prepare a smooth surface before receiving the foundation concrete. Granular A conforming to OPSS1010 compacted to minimum of 100% SPMDD shall be used for grade raise or to level any over excavation below the foundation level.

Excavation shall be kept reasonably free of water or dry and cobbles or boulders larger than 300 mm in diameter, if encountered, should be removed from the side slopes for worker safety.



## 7.3.2 Shallow Foundations

For shallow spread footings, the overburden soil below the columns and foundation walls can be excavated to the level of founding. The subgrade shall be proof rolled before constructing the spread footings.

### 7.3.2.1 Bearing Resistance

Due to the presence of a competent sand layer, shallow footings with a minimum of 1.2 m for strip footings and 1.5 m for spread footings in a shorter dimension bearing on the sand may be considered to support the structural loads of the proposed development if recommended bearing capacities are adequate.

Bearing capacities are calculated based on the methodology recommended by the Canadian Foundation Engineering Manual (CFEM). The mechanical properties of the sand layer were derived from SPT field test. The average value of SPT 'N' blows for 2B distance below the foundation level was used to estimate the effective soil friction angle,  $\phi$ . The  $\phi$ -value and the horizontal soil-footing interface friction angle,  $\delta$  are given in Table 8-2. Load and Resistance Factor Design (LRFD) approach following the National Building Code of Canada (NBCC) (2015) recommendations were used to determine the Ultimate Limit State (ULS) and Serviceability Limit State (SLS) geotechnical resistances. For ULS conditions, the unfactored ULS bearing capacity of the spread footing was determined using the general bearing capacity formula as per the CFEM (2006) using the effective soil friction angle,  $\phi$  value in Table 7-2. A geotechnical resistance factor of 0.5 as per the NBCC recommendations can be used to obtain the factored ULS bearing resistance. Furthermore, For SLS bearing capacity, allowable bearing capacity based on SPT test results and 25 mm settlement was determined.

Bearing capacities are calculated for an undisturbed subgrade. The bearing capacity of footings is also a function of the soil surcharge above the footing. Footings shall not be designed for any elevation above those noted in the bearing capacity table.

Geotechnical resistance values at the founding level (bearing capacities) are provided for Ultimate Limit State (ULS) and Serviceability Limit State (SLS). Bearing capacities are listed in the below table;

Table 7-1: Factored ULS and SLS Bearing Resistance

Footing Type	Max. D. (m)	Min. Soil Cover (m)	Min dim. (m)	ULS (kPa)	SLS (kPa)
Spread footing	121.5	1.8	1.5	300	175
Strip footing	121.5	1.8	1.2	250	150

Table 7-2: Unfactored Shearing Parameters for the Sand and Till based on SPT 'N' values

Soil Layer	$\phi$ §		$\delta'$ *
	Hatanaka and Uchida (1996)	Schmertmann (1975)	
Sand	28°	28°	21°
Till	30°	30°	21°

§  $\phi$ : Effective Soil Friction Angle

\*  $\delta'$ : Horizontal Soil-Footing Interface Friction Angle ( $\delta' = 0.75\phi$ )

### 7.3.2.2 Frost Protection

Based on the freezing index for the Southern Ontario Region provided for this site, the frost penetration depth is expected at 1.8 m below the ground surface. Frost penetration depth is estimated based on the OPSD 3090.101, Foundation Frost Penetration Depths for Southern Ontario.

The encountered native sand is classified as low frost susceptibility material based on provincial guidelines.

All perimeter and exterior foundation elements or interior foundation elements in unheated areas should be provided with a minimum of 1.8 meters of earth cover for frost protection purposes. Frost protection depth can be reduced to 1.5 m for those buildings constantly heated during the cold season.

## 7.4 Seismic Site Classification

Seismic site classification is completed based on NBCC (2015) and OBC (2012) Section 4.1.8.4 and Table 4.1.8.4.A. This classification system is based on the average soil properties in the upper 30 m and accounts for site-specific shear wave velocity, standard penetration resistance, and plasticity parameters of cohesive soils.

Selected spectral responses in the general vicinity of the site for 2% chance of exceedance in 50 years (2500 years return period) are as indicated in Table 7-3, shown below and in Appendix E;

Table 7-3: Selected Seismic Spectral Responses (2% in 50 Yrs) – NRCan 2010

Sa(0.2)	Sa(0.5)	Sa(1.0)	Sa(2.0)	PGA
0.630	0.305	0.136	0.046	0.322

Based on the subsurface condition and field and SPT values, the site can be classified as Seismic Site Class (D).

#### 7.4.1 Liquefaction Potential

Soil stratigraphy for the site consists of a thick sand deposit that extends to approximately 7.6 m below the existing ground level. The native sand layer is followed by a till layer that is approximately 1.3 m thick and followed by inferred bedrock. The groundwater is approximately at 5.7 m depth below the existing ground surface.

Liquefaction susceptibility of the native sand and till was evaluated. The native sand and till were found non-susceptible to liquefaction. The results of the analysis are presented in Appendix E.

#### 7.5 Engineered Fill

Footings shall be installed on native soil. Any over excavation shall be leveled by engineered fill. Granular A conforming to OPSS 1010 compacted to 100% Standard Proctor Maximum Dry Density (SPMDD) shall be used to level any over excavation below the foundation level. The proposed engineered fill, beyond footings influence zone, can be any material conforming to granular criteria as outlined in OPSS 1010. Material conforming to 'Granular' criteria are considered free draining and compactable and can be utilized as the engineered fill. This can apply to the backfill beyond foundation walls and engineered fill in between the footings. The engineered fill shall be compacted to a minimum of 98% SPMDD.

All fill should be placed in horizontal lifts of uniform thickness of no more than 300 mm before compaction at appropriate moisture content determined by the Proctor test. The requirement for fill material and compaction may be addressed with a note on the structural drawing for foundation or grading drawing, and with a Non-Standard Special Provision (NSSP). Any topsoil, organics, or loose sand should be removed before placing engineered fill material.

#### 7.6 Slabs-on-Grade

Slab-on-grades are considered free-floating (not attached to the foundation walls) and should be supported on a minimum of 200 mm of Granular A bedding compacted to 100% SPMDD. The requirements of the fill underneath slab-on-grade is noted in section 7.7 Engineered Fill.

If the slab on grade is proposed to support concentrated linear or point loads, the design loading shall be indicated in the structural specifications.

It is recommended that subgrade preparation and compaction efforts are approved under the supervision of a geotechnical representative.

For the design of the slab-on-grade, the modulus of subgrade reaction (k) is required. Modulus of subgrade reaction is a multi-function complex correlation that varies with the subgrade material, grade-raise fill material, and the flexural stiffness of the structural slab. However, simplified assumptions were made to estimate the

spring modulus for slab-on-grade on compacted Granular A. To estimate the modulus of subgrade reaction, it was assumed that a 2 m square section of the concrete slab-on-grade under the applied loads. Since the modulus of subgrade reaction is needed for the ultimate failure design of the slab, it is assumed the failure can occur at a 25 mm deformation. Considering these assumptions, a subgrade reaction modulus of 20,000 kN/m<sup>2</sup>/m can be used for the design of the interior slab-on-grade. This k-value is only valid for the construction of slab-on-grade on compacted Granular A bedding. This value shall not be used for the native subgrade.

## 7.7 Lateral Earth Pressure

Free draining material should be used as backfill material for foundation walls. If proper drainage is provided, “at rest” condition may be assumed for calculation of earth pressure on foundation walls. The following parameters are recommended for the granular backfill.

Table 7-4: Lateral Pressure parameters for Granular A and B and Horizontal Backfill

Pressure Parameter		Expected Value			
		Granular A	Granular B	Other OPSS1010 'Granular'	Native Sand
Unit Weight ( $\gamma$ ) kN/m <sup>3</sup>	Above groundwater	22.5	21.7	21.7	17.0
	Below groundwater	12.7	11.9	11.9	7.19
Angle of Internal Friction ( $\phi$ )		35°	32°	31°	28°
Coefficient of Active Earth Pressure ( $k_a$ )		0.27	0.31	0.32	0.36
Coefficient of Passive Earth Pressure ( $k_p$ )		3.69	3.23	3.12	2.77
Coefficient of Earth Pressure at Rest ( $k_o$ )		0.43	0.47	0.48	0.53

## 7.8 Sidewalks and Hard Surfacing

The width and extent of the sidewalks will be defined as per the architectural drawings. The designer shall provision adequate slope, based on applicable codes, to provide appropriate runoff discharge. Expansion, construction, and dummy joints shall be spaced as required by the applicable standards. Sidewalks can be categorized under residential/commercial use, and therefore, the concrete sidewalks should have a thickness of 150 to 200 mm. Requirements of OPSD 310.010 ‘Concrete Sidewalk’, OPSD 310.020 ‘Concrete Sidewalks Adjacent to Curb and Gutter’ and OPSD 310.030 ‘Concrete Sidewalk Ramps at intersection’ are recommended for the construction of the concrete sidewalk. A minimum of 150 mm bedding of OPSS Granular A compacted to 100% SPMDD is required for the concrete sidewalk panels.

All proposed new curbs shall be constructed as per applicable standards. It is recommended to follow City of Ottawa detail provided in SC3, Concrete Curb, and Sidewalk as a minimum requirement. All curbs shall receive a minimum of 150 mm Granular A bedding on approved subgrade free from soft, loose, and organic material.

## 7.9 Cement Type and Corrosion Potential

Seven soil samples were submitted to Parcel laboratories for testing of chemical properties relevant to exposure of concrete elements to sulphate attacks as well as potential soil corrosivity effects on buried metallic structural elements. Test results are presented in Table 6-4.

The potential for sulphate attack on concrete structures is moderate to low. Therefore, Type GU Portland cement may be adequate to protect buried concrete elements in the subsurface conditions encountered.

Based on electrical resistivity results and chloride content, the corrosion potential for buried steel elements is within the nonaggressive range.

## 8.0 PAVEMENT STRUCTURE

No details are provided on the traffic loads but it is understood that the parking lot and surrounding paved area is to be used frequently by light to heavy weight vehicles, and transport trucks on a daily basis. Pavement structure most likely to be placed on engineered fill material overlaying native soil. If the native soil is peat or contains high organic matter, it is recommended to be replaced with compacted Granular A or Granular B Type II and compacted to 98% SPMDD. If excavation through native subgrade is required to accommodate the pavement structure, then the subgrade should be proof rolled under the supervision of a geotechnical engineer. Should grade raise be required, compacted Granular B Type II or Granular A should be placed as needed and compacted to 98% SPMDD prior to construction of pavement structure.

The proposed pavement structure for light vehicles parking area and access road is included in Table 8-1:

Table 8-1: "Light Duty" Pavement Structure

Material		Thickness (mm)
Surface	Superpave 12.5 mm, PG 58-34	50
Base	OPSS Granular A	150
Sub-base	OPSS Granular B Type II	350

A heavier pavement structure is needed for access roads and loading docks which are known for heavy transport truck access.

Table 8-2: Truck Traffic Pavement Structure

Material		Thickness (mm)
Surface	Superpave 12.5 mm, PG 58-34	40
Binder	Superpave 19.0 mm, PG 58-34	50
Base	OPSS Granular A	150
Sub-base	OPSS Granular B Type II	450

The proposed pavement structures are designed for proof rolled subgrades or proper grade raise using granular material conforming to OPSS 1010 Granular criteria.

The base and sub base materials, i.e., Granular A for base and Granular Type B or SSM for subbase, shall be in accordance with OPSS 1010. Both base and sub-base should be compacted to 100% SPMDD. Asphalt layers should be compacted to comply with OPSS 310. Where the pavement structure is to be placed on engineered fill, the upper 600 mm of the fill should be compacted to 98% SPMDD to act as subbase.

Above recommended Superpave 12.5 and 19.0 can be replaced with HL-3 and HL-8 if required. If the required quantity of SP-19/HL-8 is small, and to avoid providing multiple asphalt mix designs, SP-19 can be replaced with SP-12.5 as long as they are placed in two separate layers. McIntosh Perry will not be responsible for cost implications of such decision.

## 9.0 CONSTRUCTION CONSIDERATIONS

Any organic material and loose sand of any kind should be removed from the footprint of the footings and all structurally load-bearing elements. Site preparation and requirements of engineered fill placement are noted in through previous sections. Refer to relevant sections for material and compaction requirements.

As noted in the previous sections, all grade adjustments due to over-excavation, within the shallow footings influence zone, shall be done using OPSS Granular A.

All backfilling shall comply with the City of Ottawa Special Provision General No. D-029 for compaction requirements, unless the design recommendations included in this report exceed provisions of D-029.

Foundation walls should be backfilled with free-draining material with granular material conforming to OPSS 1010 Granular criteria. However, the native soil can provide drainage if it is proposed to be used for any portion of the design with no compaction requirement.

A geotechnical engineer or technician should attend the site to confirm the native subgrade, type of fill material, and level of compaction. All bearing surfaces should be inspected by experienced geotechnical personnel prior to placing the footings to ensure the excavated subgrade is as the reported and recommended condition.

Vibration monitoring should be carried out during excavation and construction phases to ensure that the vibration levels at the existing surrounding structures and utilities are maintained below tolerable levels.

## 10.0 GROUNDWATER SEEPAGE

The groundwater is expected to be below the depth of the foundation level. However, depending on the construction season, surface runoff can seep into the excavation due to high hydraulic permeability of the native sand and groundwater may present above the depth of excavation. Hydraulic conductivity value of the native sand is expected approximately  $1 \times 10^{-3}$ . This hydraulic conductivity values are estimated based on soil gradation analysis. In-situ percolation tests were not performed as part of this investigation. The provided hydraulic conductivity value can be used for the selection of the pump capacity for dewatering. The excavated subgrade must be kept dry at all times to minimize the disturbance of the subgrade. If excavation proceeds below the groundwater level, the water level shall be lowered to a minimum of 1 m below the proposed bottom of excavation before excavation and compaction. Groundwater elevation is expected to fluctuate seasonally. Any surface water infiltrating into the open excavation can be removed through conventional sump and pump methods. The subgrade shall be kept dry at all times, especially before compaction and proof rolling.

Under the new regulations (O.Reg 63/16 and O.Reg 387/04), a Permit to Take Water (PTTW) is required from the Ministry of the Environment, Conservation and Parks (MOECP) if a volume of water greater than 400,000 liters per day is pumped from the excavation under normal operation, but more than 50,000 liters per day, the water taking will not require a PTTW, but will need to be registered in the EASR as a prescribed activity. Since the excavations will likely be above the groundwater level, it is considered unlikely that a PTTW would be required. The site designer shall decide on the permit application based on the expected excavation volume.

The design of the dewatering system should be the responsibility of the contractor. An outlet(s) should be identified, which the contractor can use to dispose of the pumped groundwater and incident precipitation. In order for pumped groundwater to be discharged to a City sewer, the groundwater quality needs to meet the City of Ottawa Sewer Use By-law limits, and a separate sewer discharge permit or City approval is required.

## 11.0 SITE SERVICES

At the subject site, the burial depth of water-bearing utility lines is typically 2.4 m below the ground surface. If this depth is not achievable, equivalent thermal insulation should be provided. The contractor should retain a professional engineer to provide detailed drawings for excavation and temporary support of the excavation walls during construction.

The Occupational Health and Safety Act (OHSA) of Ontario indicated that side slopes in the sand above the water table could be classified as Type 3 soil and below the water table as Type 4 soil and sloped no steeper than 3H:1V or be shored. If space restrictions exist, the excavations can be carried out within trench boxes, which is fully braced to resist lateral earth pressure.

Due to the potential for long term settlement of topsoil and organic materials and the effects of this settlement on service lines sensitive to level change, the existing topsoil, and organic materials are not considered suitable

for the support of site services. Utilities should be supported on a minimum of 150 mm bedding of Granular A compacted to a minimum of 98% of SPMDD. Utility cover can be Granular A or Granular B type II compacted to 96% SPMDD. All covers are to be compacted to 100% SPMDD if they are intersecting structural elements. The engineer designing utilities shall ensure the proposed utility pipes can tolerate compaction loads.

To extend the life of buried utilities, it is recommended utility bedding and backfill to be separated from the native soil by filter geotextile.

## 12.0 CLOSURE

We trust this geotechnical investigation report meets the requirements of your project. The “Limitations of Report” presented in Appendix A are an integral part of this report. Please contact the undersigned should you have any questions or concerns.

McIntosh Perry Consulting Engineers Ltd.



Mohammed Al-Khazaali, Ph.D., P.Eng.  
Geotechnical Engineer

N'eem Tavakkoli, M.Eng., P.Eng.  
Senior Geotechnical Engineer





## REFERENCES

- 1) Canadian Geotechnical Society, “Canadian Foundation Engineering Manual”, 4<sup>th</sup> Edition, 2006.
- 2) Ontario Ministry of Natural Resources (OMNR), Ontario Geological Survey, Special Volume 2, “The Physiography of Southern Ontario”, 3<sup>rd</sup> Edition, 1984.
- 3) Google Earth, Google, 2015.
- 4) Government of Canada, National Building Code of Canada (NBCC), “Seismic Hazard Calculation” (online), 2010.
- 5) Canadian Standards Association (CSA), “Concrete Materials and Methods of Concrete Construction”, A23.1, 2009
- 6) Government of Ontario, “Ontario Building Code (OBC),” (online), 2012.
- 7) MTO – Pavement Design and Rehabilitation Manual
- 8) Natural Resources Canada – Seismic Hazard Calculator

# GEOTECHNICAL INVESTIGATION OF OFFICE BUILDING AT 1037 CARP ROAD

## APPENDIX A LIMITATIONS OF REPORT

## LIMITATIONS OF REPORT

---

McIntosh Perry Consulting Engineers Ltd. (McIntosh Perry) carried out the field work and prepared the report. This document is an integral part of the Foundation Investigation and Design report presented.

The conclusions and recommendations provided in this report are based on the information obtained at the borehole locations where the tests were conducted. Subsurface and groundwater conditions between and beyond the boreholes may differ from those encountered at the specific locations where tests were conducted and conditions may become apparent during construction, which were not detected and could not be anticipated at the time of the site investigation. The benchmark level used and borehole elevations presented in this report are primarily to establish relative differences in elevations between the borehole locations and should not be used for other purposes such as to establish elevations for grading, depth of excavations or for planning construction.

The recommendations presented in this report for design are applicable only to the intended structure and the project described in the scope of the work, and if constructed in accordance with the details outlined in the report. Unless otherwise noted, the information contained in this report does not reflect on any environmental aspects of either the site or the subsurface conditions.

The comments or recommendation provided in this report on potential construction problems and possible construction methods are intended only to guide the designer. The number of boreholes advanced at this site may not be sufficient or adequate to reveal all the subsurface information or factors that may affect the method and cost of construction. The contractors who are undertaking the construction shall make their own interpretation of the factual data presented in this report and make their conclusions, as to how the subsurface conditions of the site may affect their construction work.

The boundaries between soil strata presented in the report are based on information obtained at the borehole locations. The boundaries of the soil strata between borehole locations are assumed from geological evidences. If differing site conditions are encountered, or if the Client becomes aware of any additional information that differs from or is relevant to the McIntosh Perry findings, the Client agrees to immediately advise McIntosh Perry so that the conclusions presented in this report may be re-evaluated.

Under no circumstances shall the liability of McIntosh Perry for any claim in contract or in tort, related to the services provided and/or the content and recommendations in this report, exceed the extent that such liability is covered by such professional liability insurance from time to time in effect including the deductible therein, and which is available to indemnify McIntosh Perry. Such errors and omissions policies are available for inspection by the Client at all times upon request, and if the Client desires to obtain further insurance to protect it against any risks beyond the coverage provided by such policies, McIntosh Perry will co-operate with the Client to obtain such insurance.

McIntosh Perry prepared this report for the exclusive use of the Client. Any use which a third party makes of this report, or any reliance on or decision to be made based on it, are the responsibility of such third parties. McIntosh Perry accepts no responsibility and will not be liable for damages, if any, suffered by any third party as a result of decisions made or actions taken based on this report.

# GEOTECHNICAL INVESTIGATION OF OFFICE BUILDING AT 1037 CARP ROAD

APPENDIX B  
FIGURES

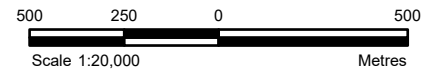
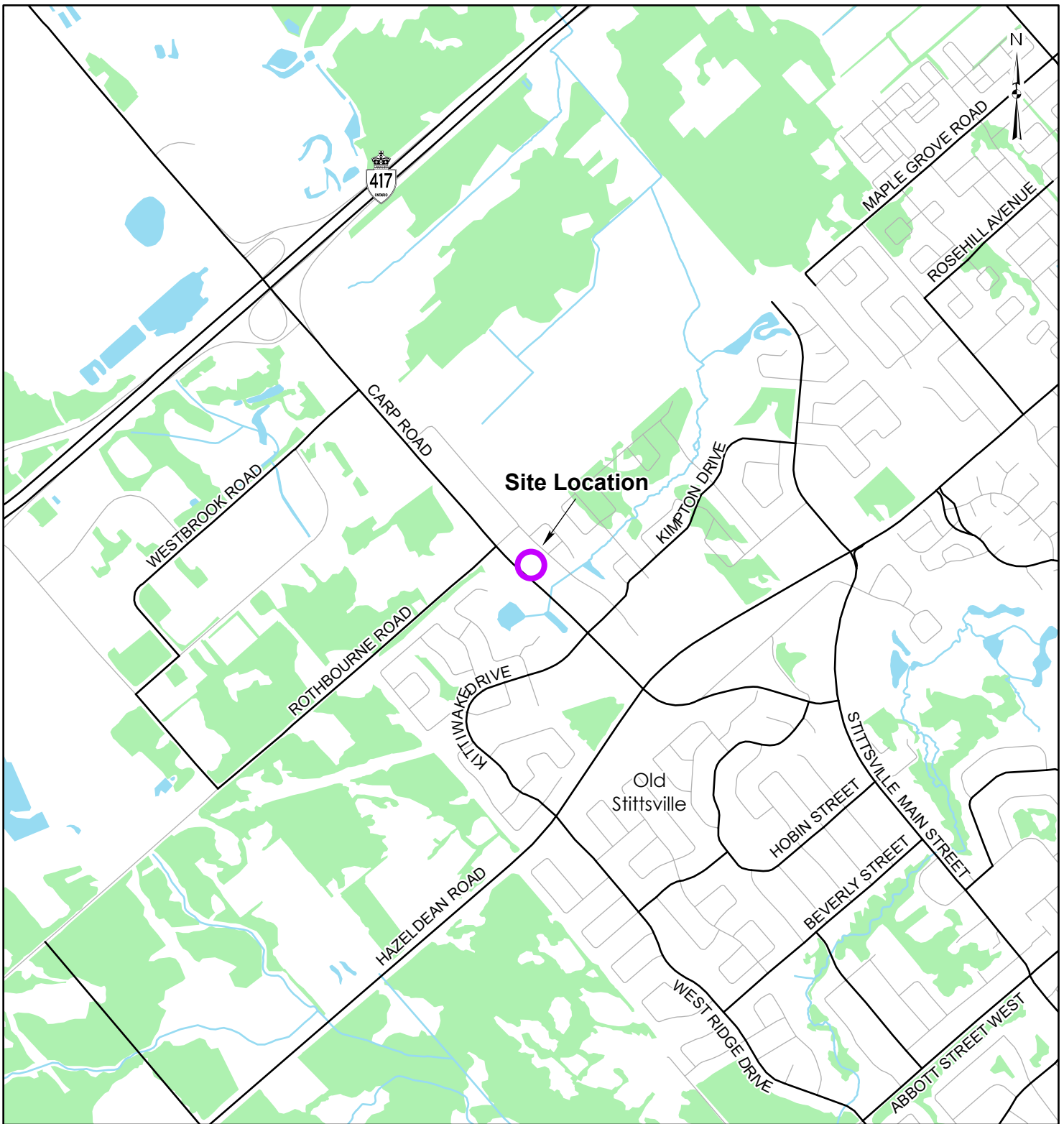

**LEGEND**

- Site Location
- Watercourse
- Local Road
- Waterbody
- Major Road
- Wooded Area

**REFERENCE**

GIS data provided by the Ontario Ministry of Natural Resources and Forestry, 2020.

CLIENT: <b>JIM BELL ARCHITECTURAL DESIGN INC.</b>	
PROJECT: <b>GEOTECHNICAL INVESTIGATION OF OFFICE BUILDINGS AT 1037 CARP ROAD</b>	
TITLE: <b>SITE LOCATION</b>	
PROJECT NO: CCO-19-0125	FIGURE: <b>1</b>
Date	Nov., 12, 2020
GIS	EU
Checked By	MA

**McINTOSH PERRY**  
 115 Walgreen Road, RR3, Carp, ON K0A1L0  
 Tel: 613-836-2184 Fax: 613-836-3742  
 www.mcintoshperry.com

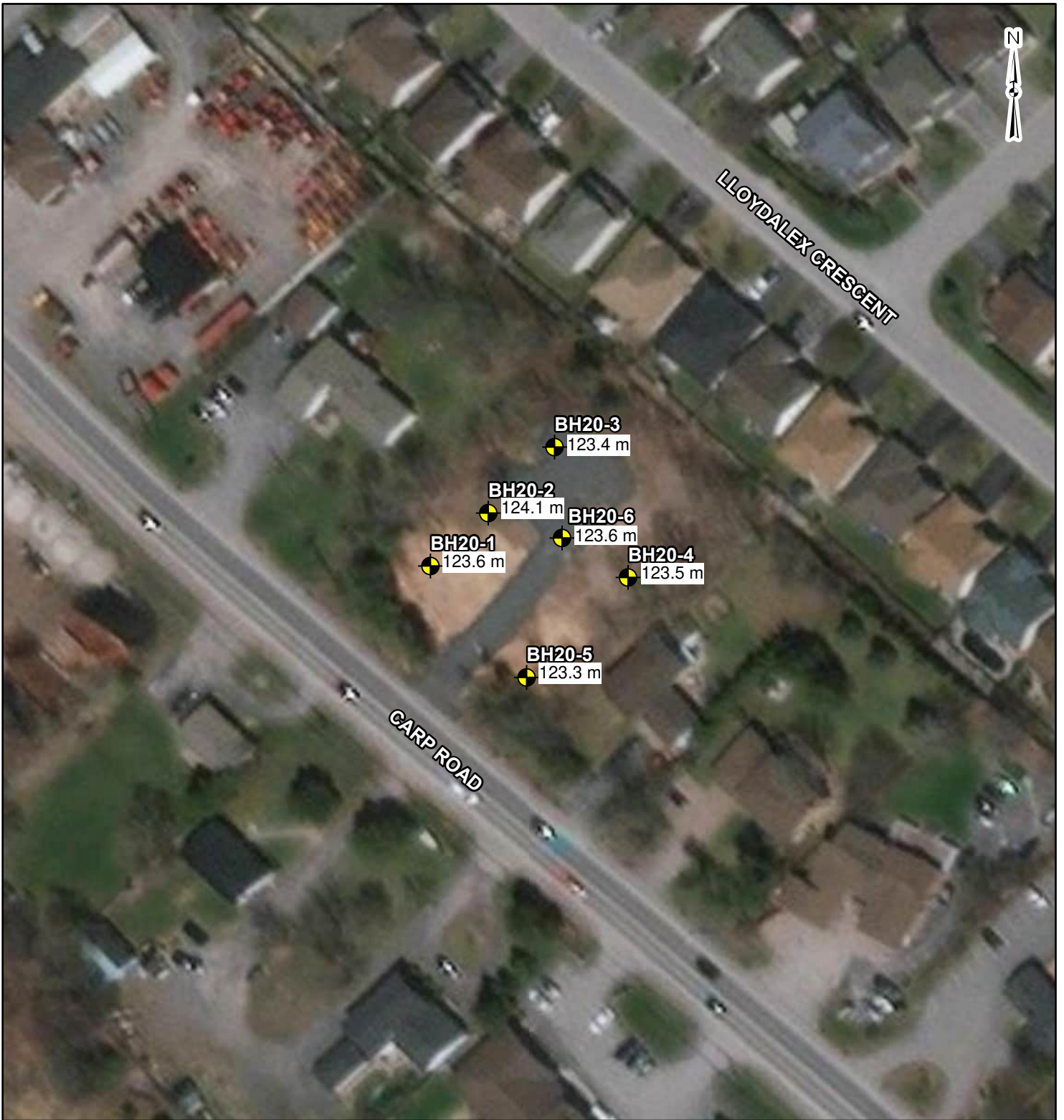

**LEGEND**

 Borehole Location

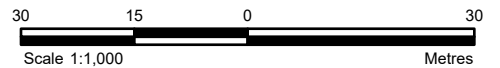

**REFERENCE**

GIS data provided by the Ontario Ministry of Natural Resources and Forestry, 2020.

CLIENT:		JIM BELL ARCHITECTURAL DESIGN INC.	
PROJECT:		GEOTECHNICAL INVESTIGATION OF OFFICE BUILDINGS AT 1037 CARP ROAD	
TITLE:		BOREHOLE LOCATIONS	
PROJECT NO: CCO-19-0125		FIGURE:	
Date	Nov., 12, 2020	2	
GIS	EU		
Checked By	MA		

**McINTOSH PERRY**  
 115 Walgreen Road, RR3, Carp, ON K0A1L0  
 Tel: 613-836-2184 Fax: 613-836-3742  
 www.mcintoshperry.com



# Particle Size Distribution Report

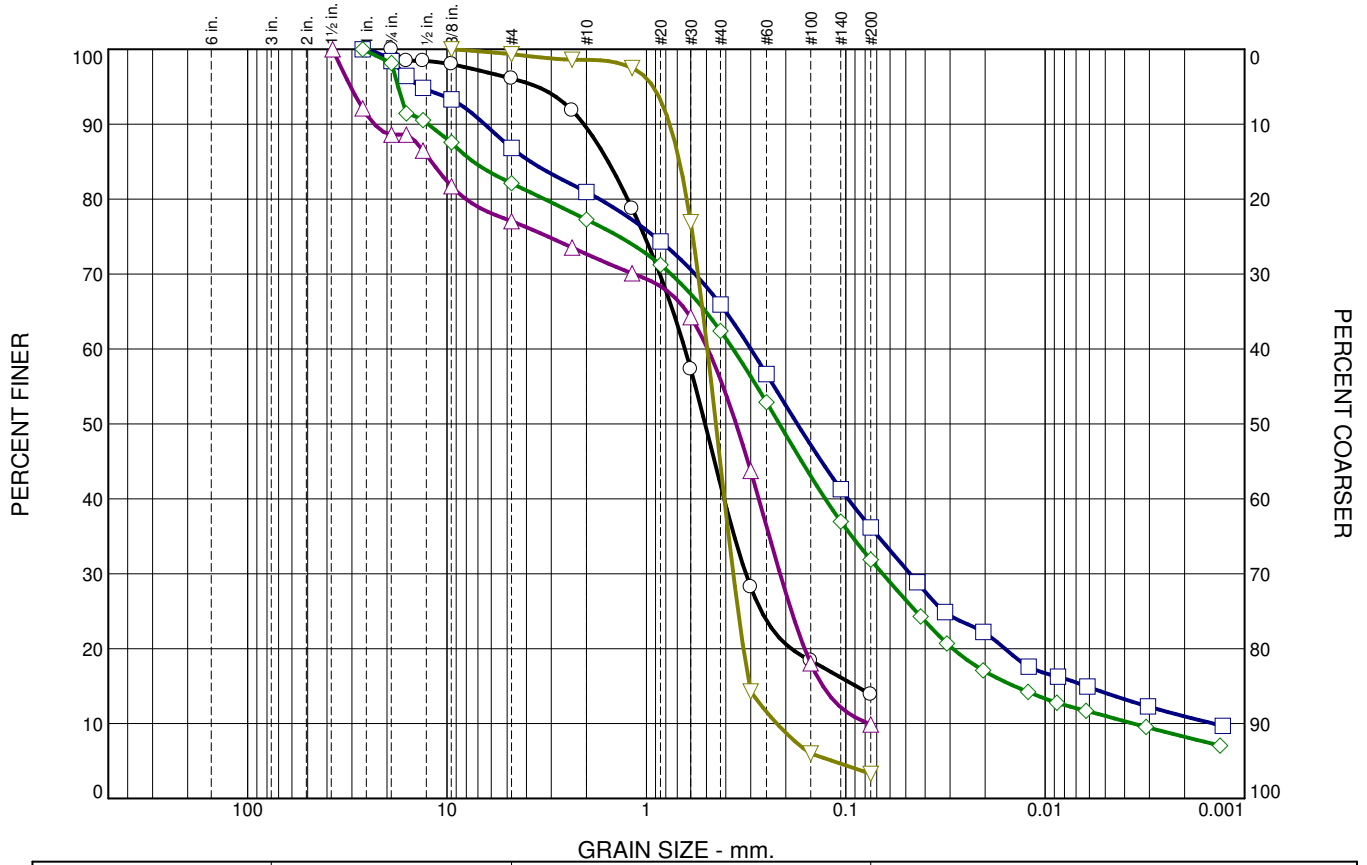

	% +75mm	% Gravel		% Sand			% Fines	
		Coarse	Fine	Coarse	Medium	Fine	Silt	Clay
○	0.0	0.0	3.9	6.5	47.7	28.0	13.9	
□	0.0	1.5	11.7	5.8	15.1	29.7	25.2	11.0
△	0.0	11.4	11.5	4.4	16.8	46.0	9.9	
◇	0.0	1.8	16.1	4.8	14.9	30.5	23.7	8.2
▽	0.0	0.0	0.7	0.7	54.1	41.2	3.3	

SOIL DATA					
SYMBOL	SOURCE	SAMPLE NO.	DEPTH (ft.)	Material Description	USCS
○	1037 Carp. Rd.	BH2001SS05	10.0-12.0'	Sand some Silt trace Gravel	
□	1037 Carp. Rd.	BH2001SS09	27.5'-29.5'	Silty Sand some Gravel some Clay	
△	1037 Carp. Rd.	BH2003SS06	15.0-17.0'	Gravelly Sand trace Silt	
◇	1037 Carp. Rd.	BH2003SS09	27.5-29.0'	Silty Sand some Gravel trace Clay	
▽	1037 Carp. Rd.	BH2005SS04	7.5-9.5'	Sand trace Silt	SP

McINTOSH PERRY

**Client:** Jim Bell Architectural Design Inc.  
**Project:** Geotech Investigation - Proposed Office Buildings 1037 Carp. Rd. Ottawa, ON.  
**Project No.:** CP19-0125

Figure 3

These results are for the exclusive use of the client for whom they were obtained.

**Checked By:** H.Smith

# Particle Size Distribution Report

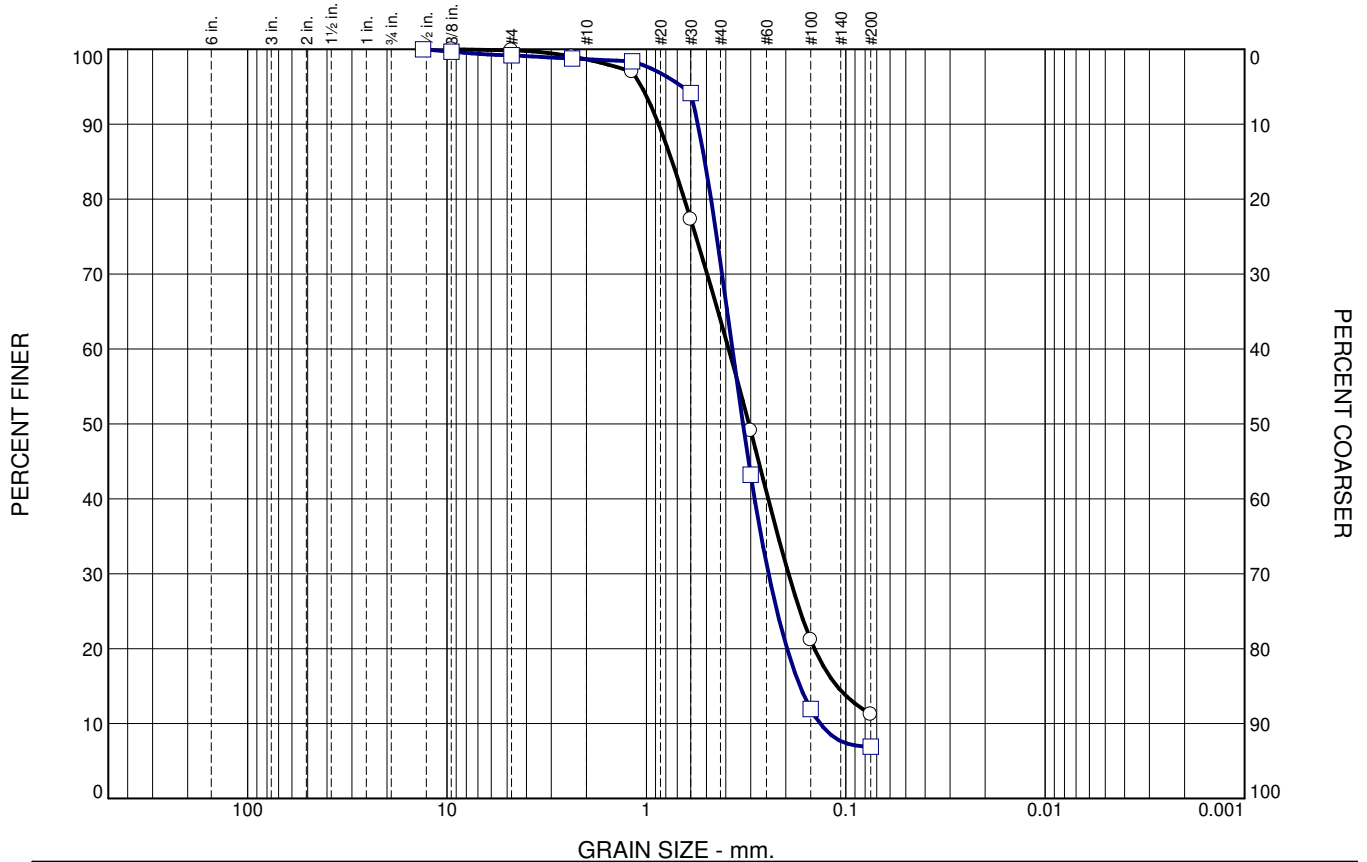

GRAIN SIZE - mm.

	% +75mm	% Gravel		% Sand			% Fines	
		Coarse	Fine	Coarse	Medium	Fine	Silt	Clay
○	0.0	0.0	0.1	1.2	34.8	52.7	11.2	
□	0.0	0.0	0.8	0.5	27.2	64.6	6.9	

## SOIL DATA

SYMBOL	SOURCE	SAMPLE NO.	DEPTH (ft.)	Material Description	USCS
○	1037 Carp. Rd.	BH2005SS08	22.5-24.5'	Sand some Silt	
□	1037 Carp. Rd.	BH2006SS03	5.0-7.0'	Sand trace Silt	

McINTOSH PERRY

**Client:** Jim Bell Architectural Design Inc.

**Project:** Geotech Investigation - Proposed Office Buildings 1037 Carp. Rd. Ottawa, ON.

**Project No.:** CP19-0125

Figure 4

These results are for the exclusive use of the client for whom they were obtained.

**Checked By:** H.Smith



# GEOTECHNICAL INVESTIGATION OF OFFICE BUILDING AT 1037 CARP ROAD

## APPENDIX C BOREHOLE LOGS

## EXPLANATION OF TERMS USED IN REPORT

**N-VALUE:** THE STANDARD PENETRATION TEST (SPT) N-VALUE IS THE NUMBER OF BLOWS REQUIRED TO CAUSE A STANDARD 51mm O.D SPLIT BARREL SAMPLER TO PENETRATE 0.3m INTO UNDISTURBED GROUND IN A BOREHOLE WHEN DRIVEN BY A HAMMER WITH A MASS OF 63.5 kg, FALLING FREELY A DISTANCE OF 0.76m. FOR PENETRATIONS OF LESS THAN 0.3m N-VALUES ARE INDICATED AS THE NUMBER OF BLOWS FOR THE PENETRATION ACHIEVED. AVERAGE N-VALUE IS DENOTED THUS  $\bar{N}$ .

**DYNAMIC CONE PENETRATION TEST:** CONTINUOUS PENETRATION OF A CONICAL STEEL POINT (51mm O.D. 60° CONE ANGLE) DRIVEN BY 475J IMPACT ENERGY ON 'A' SIZE DRILL RODS. THE RESISTANCE TO CONE PENETRATION IS MEASURED AS THE NUMBER OF BLOWS FOR EACH 0.3m ADVANCE OF THE CONICAL POINT INTO THE UNDISTURBED GROUND.

SOILS ARE DESCRIBED BY THEIR COMPOSITION AND CONSISTENCY OR DENSENESS.

**CONSISTENCY:** COHESIVE SOILS ARE DESCRIBED ON THE BASIS OF THEIR UNDRAINED SHEAR STRENGTH ( $c_u$ ) AS FOLLOWS:

$C_u$ (kPa)	0 – 12	12 – 25	25 – 50	50 – 100	100 – 200	>200
	VERY SOFT	SOFT	FIRM	STIFF	VERY STIFF	HARD

**DENSENESS:** COHESIONLESS SOILS ARE DESCRIBED ON THE BASIS OF DENSENESS AS INDICATED BY SPT N VALUES AS FOLLOWS:

N (BLOWS/0.3m)	0 – 5	5 – 10	10 – 30	30 – 50	>50
	VERY LOOSE	LOOSE	COMPACT	DENSE	VERY DENSE

ROCKS ARE DESCRIBED BY THEIR COMPOSITION AND STRUCTURAL FEATURES AND/OR STRENGTH.

**RECOVERY:** SUM OF ALL RECOVERED ROCK CORE PIECES FROM A CORING RUN EXPRESSED AS A PERCENT OF THE TOTAL LENGTH OF THE CORING RUN.

**MODIFIED RECOVERY:** SUM OF THOSE INTACT CORE PIECES, 100mm+ IN LENGTH EXPRESSED AS A PERCENT OF THE LENGTH OF THE CORING RUN. THE ROCK QUALITY DESIGNATION (RQD), FOR MODIFIED RECOVERY IS:

RQD (%)	0 – 25	25 – 50	50 – 75	75 – 90	90 – 100
	VERY POOR	POOR	FAIR	GOOD	EXCELLENT

**JOINT AND BEDDING:**

SPACING	50mm	50 – 300mm	0.3m – 1m	1m – 3m	>3m
JOINTING	VERY CLOSE	CLOSE	MOD. CLOSE	WIDE	VERY WIDE
BEDDING	VERY THIN	THIN	MEDIUM	THICK	VERY THICK

## ABBREVIATIONS AND SYMBOLS

### FIELD SAMPLING

SS	SPLIT SPOON	TP	THINWALL PISTON
WS	WASH SAMPLE	OS	OSTERBERG SAMPLE
ST	SLOTTED TUBE SAMPLE	RC	ROCK CORE
BS	BLOCK SAMPLE	PH	TW ADVANCED HYDRAULICALLY
CS	CHUNK SAMPLE	PM	TW ADVANCED MANUALLY
TW	THINWALL OPEN	FS	FOIL SAMPLE

### STRESS AND STRAIN

$u_w$	kPa	PORE WATER PRESSURE
$r_u$	1	PORE PRESSURE RATIO
$\sigma$	kPa	TOTAL NORMAL STRESS
$\sigma'$	kPa	EFFECTIVE NORMAL STRESS
$\tau$	kPa	SHEAR STRESS
$\sigma_1, \sigma_2, \sigma_3$	kPa	PRINCIPAL STRESSES
$\epsilon$	%	LINEAR STRAIN
$\epsilon_1, \epsilon_2, \epsilon_3$	%	PRINCIPAL STRAINS
E	kPa	MODULUS OF LINEAR DEFORMATION
G	kPa	MODULUS OF SHEAR DEFORMATION
$\mu$	1	COEFFICIENT OF FRICTION

### MECHANICAL PROPERTIES OF SOIL

$m_v$	$\text{kPa}^{-1}$	COEFFICIENT OF VOLUME CHANGE
$c_c$	1	COMPRESSION INDEX
$c_s$	1	SWELLING INDEX
$c_a$	1	RATE OF SECONDARY CONSOLIDATION
$c_v$	$\text{m}^2/\text{s}$	COEFFICIENT OF CONSOLIDATION
H	m	DRAINAGE PATH
$T_v$	1	TIME FACTOR
U	%	DEGREE OF CONSOLIDATION
$\sigma'_{v0}$	kPa	EFFECTIVE OVERBURDEN PRESSURE
$\sigma'_p$	kPa	PRECONSOLIDATION PRESSURE
$\tau_r$	kPa	SHEAR STRENGTH
$c'$	kPa	EFFECTIVE COHESION INTERCEPT
$\Phi$	-°	EFFECTIVE ANGLE OF INTERNAL FRICTION
$c_u$	kPa	APPARENT COHESION INTERCEPT
$\Phi_u$	-°	APPARENT ANGLE OF INTERNAL FRICTION
$\tau_R$	kPa	RESIDUAL SHEAR STRENGTH
$\tau_r$	kPa	REMOULDED SHEAR STRENGTH
$S_t$	1	SENSITIVITY = $c_u / \tau_r$

### PHYSICAL PROPERTIES OF SOIL

$\rho_s$	$\text{kg}/\text{m}^3$	DENSITY OF SOLID PARTICLES	e	1, %	VOID RATIO	$e_{min}$	1, %	VOID RATIO IN DENSEST STATE
$\gamma_s$	$\text{kN}/\text{m}^3$	UNIT WEIGHT OF SOLID PARTICLES	n	1, %	POROSITY	$I_D$	1	DENSITY INDEX = $\frac{e_{max} - e}{e_{max} - e_{min}}$
$\rho_w$	$\text{kg}/\text{m}^3$	DENSITY OF WATER	w	1, %	WATER CONTENT	D	mm	GRAIN DIAMETER
$\gamma_w$	$\text{kN}/\text{m}^3$	UNIT WEIGHT OF WATER	$s_r$	%	DEGREE OF SATURATION	$D_n$	mm	N PERCENT – DIAMETER
$\rho$	$\text{kg}/\text{m}^3$	DENSITY OF SOIL	$w_L$	%	LIQUID LIMIT	$C_u$	1	UNIFORMITY COEFFICIENT
$\gamma$	$\text{kN}/\text{m}^3$	UNIT WEIGHT OF SOIL	$w_p$	%	PLASTIC LIMIT	h	m	HYDRAULIC HEAD OR POTENTIAL
$\rho_d$	$\text{kg}/\text{m}^3$	DENSITY OF DRY SOIL	$w_s$	%	SHRINKAGE LIMIT	q	$\text{m}^3/\text{s}$	RATE OF DISCHARGE
$\gamma_d$	$\text{kN}/\text{m}^3$	UNIT WEIGHT OF DRY SOIL	$I_p$	%	PLASTICITY INDEX = $(W_L - W_P)$	v	m/s	DISCHARGE VELOCITY
$\rho_{sat}$	$\text{kg}/\text{m}^3$	DENSITY OF SATURATED SOIL	$I_L$	1	LIQUIDITY INDEX = $(W - W_P) / I_p$	i	1	HYDAULIC GRADIENT
$\gamma_{sat}$	$\text{kN}/\text{m}^3$	UNIT WEIGHT OF SATURATED SOIL	$I_C$	1	CONSISTENCY INDEX = $(W_L - W) / I_p$	k	m/s	HYDRAULIC CONDUCTIVITY
$\rho^*$	$\text{kg}/\text{m}^3$	DENSITY OF SUBMERGED SOIL	$e_{max}$	1, %	VOID RATIO IN LOOSEST STATE	j	$\text{KN}/\text{m}^3$	SEEPAGE FORCE
$\gamma^*$	$\text{kN}/\text{m}^3$	UNIT WEIGHT OF SUBMERGED SOIL						





DATE: 14/10/2020 - 14/10/2020  
 PROJECT: 19-0125 1037\_CARP  
 CLIENT: Jim Bell Architectural Design Inc.  
 ELEVATION: 124.10 m

LOCATION: 1037 Carp Road, Ottawa  
 COORDINATES: Lat: 45.271908 , Lon: -75.944623  
 DATUM: Geodetic  
 REMARK:

ORIGINATED BY: A.L.  
 COMPILED BY: AL  
 CHECKED BY: NT  
 REPORT DATE: 13/11/2020

DEPTH - feet	DEPTH - meters	SOIL PROFILE		SYMBOL	SAMPLES				GROUNDWATER CONDITIONS	DYNAMIC CONE PEN. RESISTANCE PLOT		WATER CONTENT and LIMITS (%)			REMARKS & GRAIN SIZE DISTRIBUTION (%)					
		ELEVATION - m	DEPTH - m		DESCRIPTION	TYPE AND NUMBER	STATE	RECOVERY		"N" or RQD	20	40	60	80		W <sub>P</sub>	W	W <sub>L</sub>		
		124.1		Natural ground surface																
		0.0		Topsoil: Peat, dark brown, dry, loose. Presence of organic matter.																
		123.5		Sand, traces of silt, light brown, dry, compact.																
	1	0.6			SS-01	X	29	9												
	5				SS-02	X	79	22												
	2				SS-03	X	79	20												
	3				SS-04	X	79	22												
	10				SS-05	X	75	9												
	4																			
	5																			
	15																			
	5																			
	6																			
	20																			
	7																			
	25																			
	8	116.5		Silty sand, grey, wet, very loose to loose.																
		7.6			SS-08	X	100	2												
	9																			
		115.2		Inferred Bedrock END OF BOREHOLE Water was measured in open																
	30	8.9			SS-09	X	44	REF												

5.8 m

Split spoon sampler refusal at 8.8 m  
 Auger refusal at 8.9 m

I:\LICENSES\7\Sobek\Geotec80\Style\Log\_Borehole\_v5\_NEW.sty

DATE: 14/10/2020 - 14/10/2020  
 PROJECT: 19-0125 1037\_CARP  
 CLIENT: Jim Bell Architectural Design Inc.  
 ELEVATION: 123.40 m

LOCATION: 1037 Carp Road, Ottawa  
 COORDINATES: Lat: 45.272017, Lon: -75.944466  
 DATUM: Geodetic  
 REMARK:

ORIGINATED BY: A.L.  
 COMPILED BY: M.A.  
 CHECKED BY: NT  
 REPORT DATE: 13/11/2020

DEPTH - feet	DEPTH - meters	SOIL PROFILE		SYMBOL	SAMPLES				GROUNDWATER CONDITIONS	DYNAMIC CONE PEN. RESISTANCE PLOT 20 40 60 80	SHEAR STRENGTH (kPa) Vane test: Intact (◇), Remolded (◆); Lab vane: Intact (□), Remolded (■)	WATER CONTENT and LIMITS (%)			REMARKS & GRAIN SIZE DISTRIBUTION (%)				
		ELEVATION - m	DEPTH - m		DESCRIPTION	TYPE AND NUMBER	STATE	RECOVERY				"N" or RQD	W <sub>P</sub>	W		W <sub>L</sub>	G	S	M
		123.4		Natural ground surface															
		0.0	123.2	Topsoil: Gravel, peat, Presence of cobbles and organic matter.															
		0.2		Topsoil: Peat and organic matter, dark brown, dry to moist.															
	1	122.5	0.9	Sand, traces of silt and gravel, light brown, dry, compact.	SS-01	0	5												
	5				SS-02	29	7												
	2				SS-03	87	28												
					SS-04	96	22												
	10				SS-05	100	26												
	4																		
	15	119.0	4.4	Gravelly sand, traces of silt, light brown, damp to moist, compact. Presence of cobbles.	SS-06	92	58										22	68	10
	5																	Auger rattling	
		117.9	5.5	Sand, traces of silt and gravel, brown, wet, compact.															
	6				SS-07	92	23												
	7																		
	25	115.8	7.6	Silty sand, some gravel, traces of clay, grey, wet, loose.	SS-08	29	6												
	8																		
		114.5	8.9	Inferred Bedrock	SS-09	95	REF												
	9			END OF BOREHOLE															
	30			Water was measured in open															

I:\LICENSES7\Sobek\Geotec80\Style\Log\_Borehole\_v5\_NEW.sty

DATE: 15/10/2020 - 15/10/2020  
 PROJECT: 19-0125 1037\_CARP  
 CLIENT: Jim Bell Architectural Design Inc.  
 ELEVATION: 123.50 m

LOCATION: 1037 Carp Road, Ottawa  
 COORDINATES: Lat: 45.271800, Lon: -75.944295  
 DATUM: Geodetic  
 REMARK:

ORIGINATED BY: A.L.  
 COMPILED BY: M.A.  
 CHECKED BY: N.T.  
 REPORT DATE: 13/11/2020

DEPTH - feet	DEPTH - meters	SOIL PROFILE		SYMBOL	SAMPLES				GROUNDWATER CONDITIONS	DYNAMIC CONE PEN. RESISTANCE PLOT		WATER CONTENT and LIMITS (%)			REMARKS & GRAIN SIZE DISTRIBUTION (%)			
		ELEVATION - m	DEPTH - m		DESCRIPTION	TYPE AND NUMBER	STATE	RECOVERY		"N" or RQD	20	40	60	80		W <sub>P</sub>	W	W <sub>L</sub>
		123.5		Natural ground surface														
		0.0		Topsoil: Peat and organic matter, dark brown, dry, loose.														
		123.0		Sand, traces of silt and gravel, light brown, dry to moist, compact.														
	1	0.5			SS-01	X	29	7										
	5				SS-02	X	100	24										
	2				SS-03	X	100	25										
	3				SS-04	X	75	30										
	10				SS-05	X	100	24										
	4																	
	15				SS-06	X	79	18										
	5																	
	20				SS-07	X		14										
	7																	
	25	115.9	7.6	Silty sand, grey, wet, very loose.	SS-08	X	25	1										
	8				SS-09	X	83	REF										
	9	114.9	8.6	Inferred Bedrock END OF BOREHOLE Water was measured in open														
	30																	

I:\LICENSES\7\Sobek\Geotec80\Style\Log\_Borehole\_v5\_NEW.sty

5.8 m

DATE: 15/10/2020 - 15/10/2020  
 PROJECT: 19-0125 1037\_CARP  
 CLIENT: Jim Bell Architectural Design Inc.  
 ELEVATION: 123.30 m

LOCATION: 1037 Carp Road, Ottawa  
 COORDINATES: Lat: 45.271635, Lon: -75.944536  
 DATUM: Geodetic  
 REMARK:

ORIGINATED BY: A.L.  
 COMPILED BY: M.A.  
 CHECKED BY: NT  
 REPORT DATE: 13/11/2020

DEPTH - feet	DEPTH - meters	SOIL PROFILE		SYMBOL	SAMPLES				GROUNDWATER CONDITIONS	DYNAMIC CONE PEN. RESISTANCE PLOT		WATER CONTENT and LIMITS (%)			REMARKS & GRAIN SIZE DISTRIBUTION (%)			
		ELEVATION - m	DEPTH - m		DESCRIPTION	TYPE AND NUMBER	STATE	RECOVERY		"N" or RQD	20	40	60	80		W <sub>P</sub>	W	W <sub>L</sub>
		123.3		Natural ground surface														
		0.0		Topsoil: Peat, wood chips, organic matter.	SS-01	0	2											
		122.7		Sand, traces of silt and gravel, light brown to brown, dry, Loose to compact.	SS-02	54	8											
1		0.6			SS-03	75	15											
5					SS-04	71	15											
2					SS-05	33	27											
10					SS-06	75	15											
4				Sand, some silt, grey, wet, compact to dense.	SS-07	92	16											
15					SS-08	62	32											
5					SS-09	71	54											
6		117.2																
20		6.1																
7																		
25																		
8		115.1																
		8.2		END OF BOREHOLE														
9				Water was measured in open borehole														
30																		

I:\LICENSES\7\Sobek\Geotec80\Style\Log\_Borehole\_v5\_NEW.sty

6.1 m

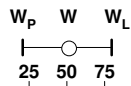
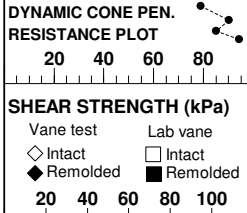

G S M C

1 96 4

0 89 11





# GEOTECHNICAL INVESTIGATION OF OFFICE BUILDING AT 1037 CARP ROAD

## APPENDIX D LAB RESULTS

Only selected pages from the third-party lab are included in this appendix

## Certificate of Analysis

**McIntosh Perry Consulting Eng. (Nepean)**

215 Menten Place, Unit 104  
Nepean, ON K2H 9C1  
Attn: Harrison Smith

Client PO:  
Project: CP19-0125  
Custody: 128663

Report Date: 2-Nov-2020  
Order Date: 28-Oct-2020

**Order #: 2044382**

This Certificate of Analysis contains analytical data applicable to the following samples as submitted:

Paracel ID	Client ID
2044382-01	BH20-01 SS03 - Carp Rd.
2044382-02	BH20-03 SS03 - Carp Rd.

Approved By:



Mark Foto, M.Sc.  
Lab Supervisor

Certificate of Analysis

Report Date: 02-Nov-2020

Client: McIntosh Perry Consulting Eng. (Nepean)

Order Date: 28-Oct-2020

Client PO:

Project Description: CP19-0125

**Analysis Summary Table**

Analysis	Method Reference/Description	Extraction Date	Analysis Date
Anions	EPA 300.1 - IC, water extraction	30-Oct-20	30-Oct-20
pH, soil	EPA 150.1 - pH probe @ 25 °C, CaCl buffered ext.	28-Oct-20	29-Oct-20
Resistivity	EPA 120.1 - probe, water extraction	30-Oct-20	30-Oct-20
Solids, %	Gravimetric, calculation	29-Oct-20	29-Oct-20

Certificate of Analysis

Report Date: 02-Nov-2020

Client: McIntosh Perry Consulting Eng. (Nepean)

Order Date: 28-Oct-2020

Client PO:

Project Description: CP19-0125

<b>Client ID:</b>	BH20-01 SS03 - Carp Rd.	BH20-03 SS03 - Carp Rd.	-	-
<b>Sample Date:</b>	15-Oct-20 09:00	15-Oct-20 09:00	-	-
<b>Sample ID:</b>	2044382-01	2044382-02	-	-
<b>MDL/Units</b>	Soil	Soil	-	-

**Physical Characteristics**

% Solids	0.1 % by Wt.	96.6	94.3	-	-
----------	--------------	------	------	---	---

**General Inorganics**

pH	0.05 pH Units	8.06	7.92	-	-
Resistivity	0.10 Ohm.m	126	92.0	-	-

**Anions**

Chloride	5 ug/g dry	9	7	-	-
Sulphate	5 ug/g dry	<5	<5	-	-

Certificate of Analysis

Report Date: 02-Nov-2020

Client: McIntosh Perry Consulting Eng. (Nepean)

Order Date: 28-Oct-2020

Client PO:

Project Description: CP19-0125

**Qualifier Notes:**

None

**Sample Data Revisions**

None

**Work Order Revisions / Comments:**

None

**Other Report Notes:**

n/a: not applicable

ND: Not Detected

MDL: Method Detection Limit

Source Result: Data used as source for matrix and duplicate samples

%REC: Percent recovery.

RPD: Relative percent difference.

NC: Not Calculated

Soil results are reported on a dry weight basis when the units are denoted with 'dry'.

Where %Solids is reported, moisture loss includes the loss of volatile hydrocarbons.

# GEOTECHNICAL INVESTIGATION OF OFFICE BUILDING AT 1037 CARP ROAD

## APPENDIX E SEISMIC HAZARD CALCULATION



# 2010 National Building Code Seismic Hazard Calculation

INFORMATION: Eastern Canada English (613) 995-5548 français (613) 995-0600 Facsimile (613) 992-8836  
Western Canada English (250) 363-6500 Facsimile (250) 363-6565

Site: 45.272N 75.945W

User File Reference: 1037 Carp Road

2020-11-12 15:13 UT

Requested by: McIntosh Perry

Probability of exceedance per annum	0.000404	0.001	0.0021	0.01
Probability of exceedance in 50 years	2 %	5 %	10 %	40 %
Sa (0.2)	0.600	0.369	0.234	0.083
Sa (0.5)	0.293	0.178	0.117	0.041
Sa (1.0)	0.132	0.084	0.053	0.017
Sa (2.0)	0.044	0.027	0.017	0.006
PGA (g)	0.308	0.191	0.115	0.034

**Notes:** Spectral ( $S_a(T)$ , where  $T$  is the period in seconds) and peak ground acceleration (PGA) values are given in units of  $g$  ( $9.81 \text{ m/s}^2$ ). Peak ground velocity is given in  $\text{m/s}$ . Values are for "firm ground" (NBCC2015 Site Class C, average shear wave velocity  $450 \text{ m/s}$ ). NBCC2015 and CSAS6-14 values are highlighted in yellow. Three additional periods are provided - their use is discussed in the NBCC2015 Commentary. Only 2 significant figures are to be used. **These values have been interpolated from a 10-km-spaced grid of points. Depending on the gradient of the nearby points, values at this location calculated directly from the hazard program may vary. More than 95 percent of interpolated values are within 2 percent of the directly calculated values.**

---

## References

**National Building Code of Canada 2015 NRCC no. 56190;** Appendix C: Table C-3, Seismic Design Data for Selected Locations in Canada

**Structural Commentaries (User's Guide - NBC 2015: Part 4 of Division B)**  
**Commentary J:** Design for Seismic Effects

**Geological Survey of Canada Open File 7893** Fifth Generation Seismic Hazard Model for Canada: Grid values of mean hazard to be used with the 2015 National Building Code of Canada

See the websites [www.EarthquakesCanada.ca](http://www.EarthquakesCanada.ca) and [www.nationalcodes.ca](http://www.nationalcodes.ca) for more information



Natural Resources  
Canada

Ressources naturelles  
Canada

Canada

**Liquefaction Evaluation for the Proposed Development on  
1037 Carp Road  
Project #: CP-19-0125**

Soil stratigraphy for the site consists of a thick sand deposit that extends to approximately 7.6 m below the existing ground level. The native sand layer is followed by a till layer that is approximately 1.3 m thick and followed by inferred bedrock. The groundwater is approximately at 5.7 m depth below the existing ground surface. Herein liquefaction susceptibility of the native sand layer and the till layer is evaluated.

For coarse-grained soils with fines content up to 35%, the corrected SPT resistance can be used to determine the susceptibility of the coarse-grained soil to liquefaction according to Canadian Foundation Engineering Manual CFEM (2006). Seven representative samples from the native sand and till layers underwent grain size analysis. The percentage of gravel, sand, silt and clay are presented in Table 1.

**Table 1: Grain Size Distribution of native Sand/Silty Sand**

Borehole No.	Sample No.	(N <sub>1</sub> ) <sub>60</sub>	Depth (m)	Gravel (%)	Sand (%)	Silt (%)	Clay (%)	r <sub>d</sub>	CSR
BH20-01	○ SS-05	9	3.0 – 3.6	4	82	15		0.97	0.020
BH20-01	△ SS-09	11	8.3 – 8.9	13	51	26	11	0.93	0.024
BH20-03	◇ SS-06	64	4.5 – 5.1	22	68	10		0.96	0.020
BH20-03	□ SS-09	8	7.6 – 8.2	17	52	23	8	0.94	0.023
BH20-05	▽ SS-04	23	2.3 – 2.9	1	96	4		0.98	0.020
BH20-05	⬢ SS-08	40	8.3 – 8.9	0	89	11		0.93	0.024
BH20-05	⊕ SS-03	34	1.5 – 2.1	1	93	7		0.99	0.020

To evaluate the liquefaction susceptibility of the native sand and till layers using SPT test results, Cyclic Stress Ratio (CSR) has to be estimated based on site seismicity characteristics that were obtained from seismic calculator available on Natural Resources Canada website. CSR can be calculated using the following formula:

$$CSR = 0.65 \times \frac{a_{max} \cdot \sigma_v}{g \cdot \sigma'_{v0}} \times r_d$$

where  $a_{max}$  is the peak ground surface acceleration for the designed earthquake,  $g$  is gravity acceleration (9.81 m/s<sup>2</sup>),  $\sigma_v$  is total vertical overburden pressure,  $\sigma'_{v0}$  is the initial effective overburden pressure and  $r_d$  is stress reduction factor at the depth of interest.  $r_d$  and CSR values are presented in Table 1.

Based on the calculated CSR and corrected SPT values, Figure 1 from CFEM can be used to evaluate the native sand and till layers susceptibility to liquefaction. The CSR results and the corrected SPT 'N' values were plotted on the figure and the native sand and till layers were found to be non-susceptible to liquefaction.

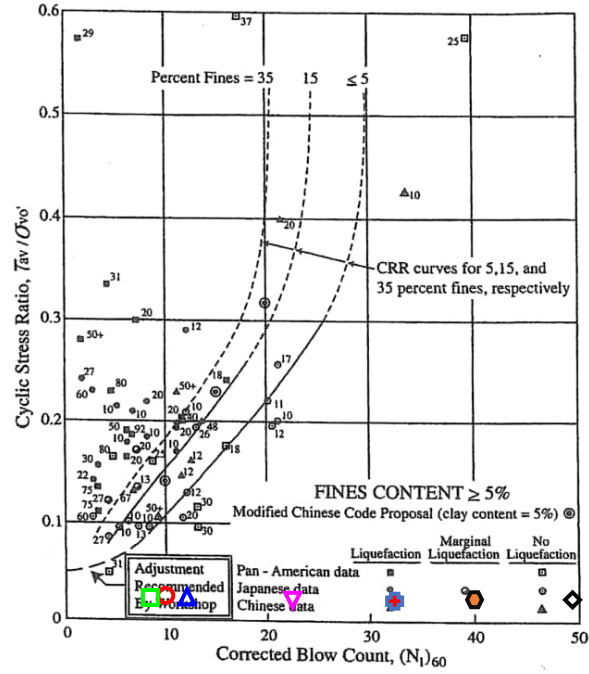
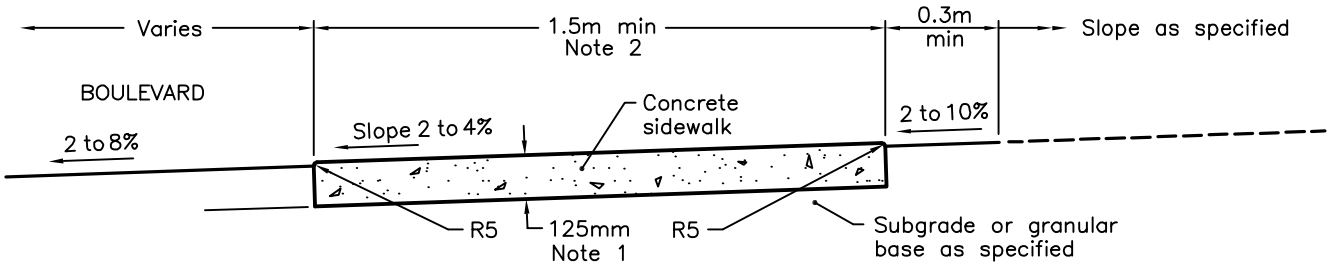

Figure 1: CRS vs Corrected SPT N value,  $(N_1)_{60}$  (modified from CFEM 2006)

# GEOTECHNICAL INVESTIGATION OF OFFICE BUILDING AT 1037 CARP ROAD

## APPENDIX F RELEVANT STANDARDS



**TYPICAL SECTION**

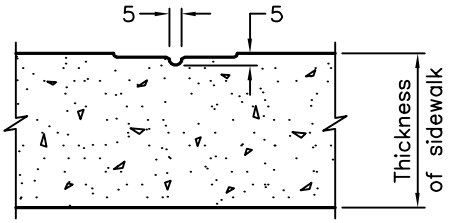

**DUMMY JOINT (OPTIONAL)**

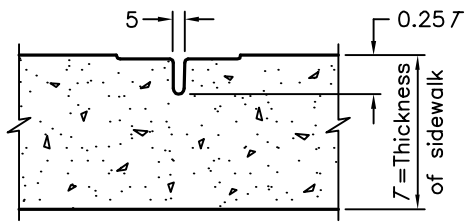

**CONTRACTION JOINT**

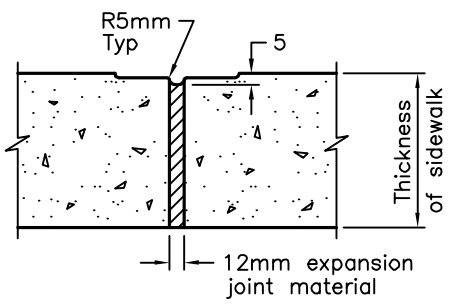

**EXPANSION JOINT**

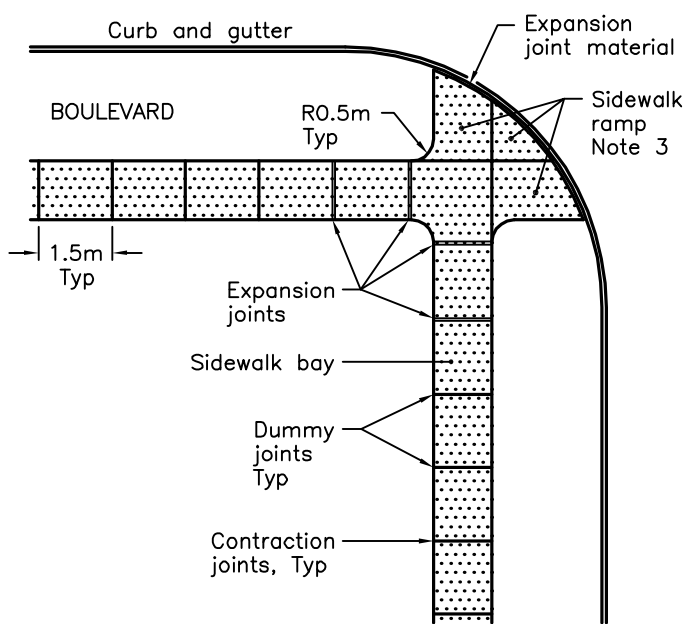

**JOINT LAYOUT**

**NOTES:**

- 1 Sidewalk thickness at residential driveways and adjacent to curb shall be 150mm. At commercial and industrial driveways, the thickness shall be 200mm.
- 2 Sidewalk width shall be wider when specified.
- 3 This OPSD shall be read in conjunction with OPSD 310.030, 310.031, 310.032, 310.033 and 310.039.
- A All dimensions are in millimetres unless otherwise shown.

ONTARIO PROVINCIAL STANDARD DRAWING	Nov 2015	Rev 2	
<b>CONCRETE SIDEWALK</b>	-----		
<b>OPSD 310.010</b>			



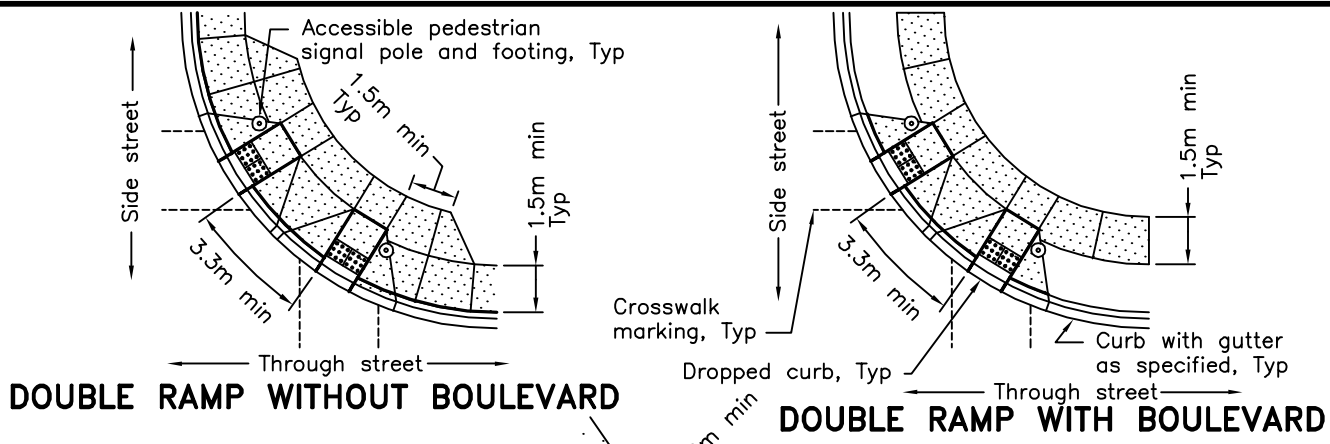

**DOUBLE RAMP WITHOUT BOULEVARD**

**DOUBLE RAMP WITH BOULEVARD**

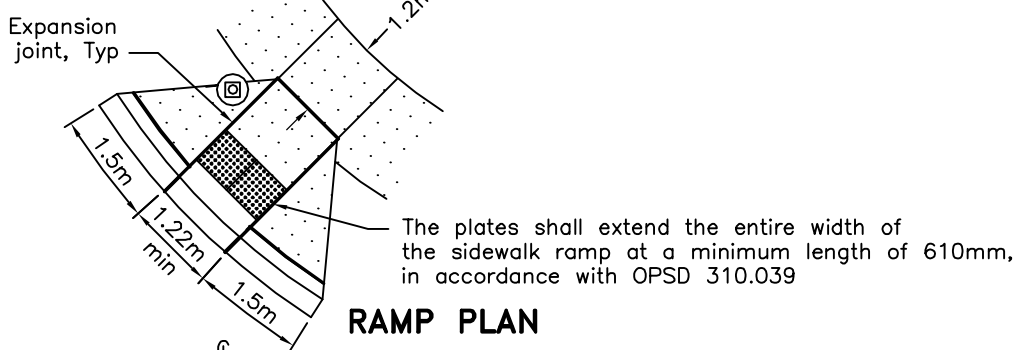

**RAMP PLAN**

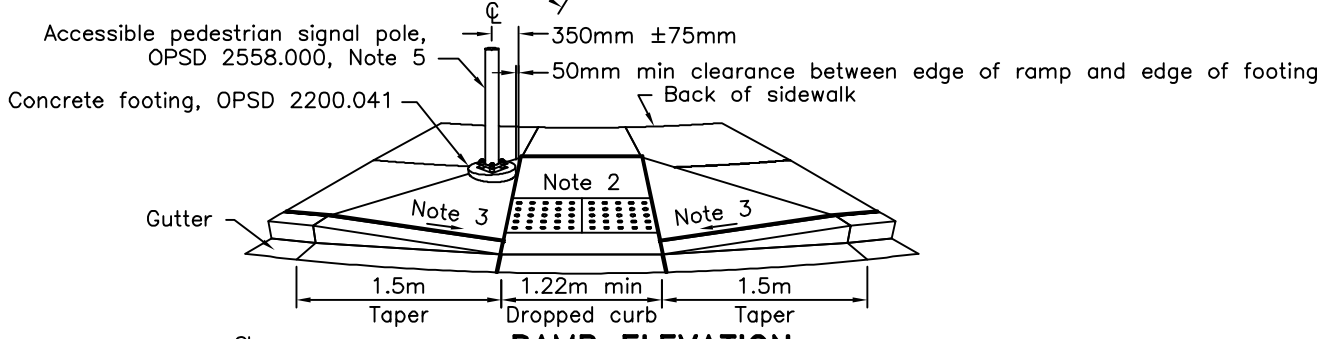

**RAMP ELEVATION**

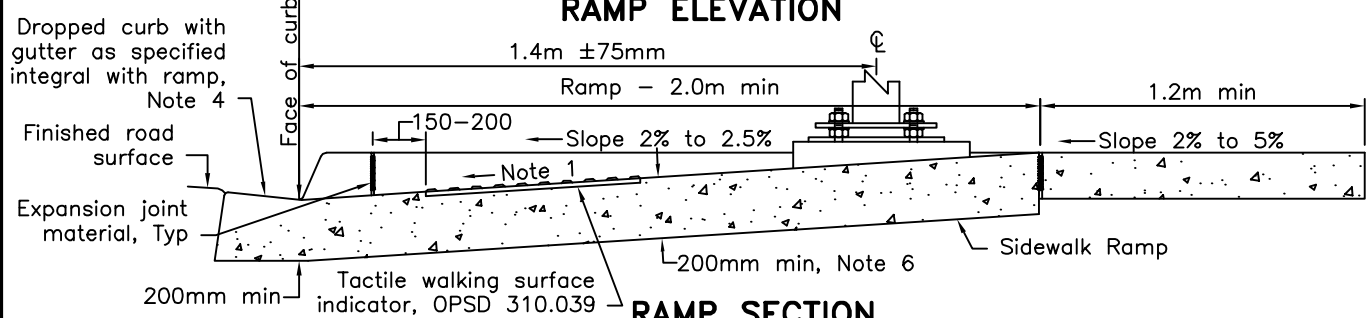

**RAMP SECTION**

- NOTES:**
- 1 Slope of ramp shall not exceed 8%.
  - 2 Cross slope of ramp shall not exceed 2% in either direction.
  - 3 Cross slope of flared side of ramp shall not exceed 8%.
  - 4 Dropped curb at ramp shall be modified to eliminate 30 mm step at gutter.
  - 5 Accessible pedestrian signal to have tactile arrow that aligns with direction of crosswalk.
  - 6 Minimum thickness of ramp is 200mm. Minimum thickness of sidewalk and flared sides adjacent to ramp is 150mm.
- A Where only one crosswalk is present at an intersection, only one curb ramp is required.  
 B All dimensions are in millimetres unless otherwise shown.

ONTARIO PROVINCIAL STANDARD DRAWING	Nov 2015	Rev 1	
<b>CONCRETE SIDEWALK RAMPS AT SIGNALIZED INTERSECTIONS</b>	-----		
<b>OPSD 310.030</b>			





## APPENDIX B – MONITORING WELL LOGS

PROJECT NO.: **OCP-19-0125**  
 PROJECT: Office Building  
 CLIENT: Jim Bell  
 PROJECT LOCATION: 1037 Carp Road

DRILLING DATA  
 Date: Oct-12-2022  
 Method: Hollow Stem Auger  
 Diameter: 200 mm  
 BH Location:

BH No: **22-1 MW**  
 DATUM:  
 ENCL NO.: 1

SOIL PROFILE		SAMPLES				DYNAMIC CONE PENETRATION RESISTANCE PLOT 20 40 60 80	PLASTIC LIMIT W <sub>p</sub>	NATURAL MOISTURE CONTENT w	LIQUID LIMIT W <sub>L</sub>	Remarks and Grain Size Distribution (%) Unit Weight (kN/m <sup>3</sup> ) Pocket Penetro. (kPa)
ELEV DEPTH	DESCRIPTION	STRATA PLOT NUMBER	TYPE	"N" BLOWS 0.3 m	GROUND WATER CONDITIONS DEPTH					
124.6	Granular Bedding									GR SA SI CL
0.0	<b>WELL INSTALLTION ONLY</b>									
1.0										
2.0										
3.0										
4.0										
5.0										
6.0										
7.0										
8.0										
9.0										
10.0										
11.0										
12.0										
13.0										
14.0										
15.0										
16.0										
17.0										
18.0										
19.0										
20.0										
21.0										
22.0										
23.0										
24.0										
25.0										
26.0										
27.0										
28.0										
29.0										
30.0										
31.0										
32.0										
33.0										
34.0										
35.0										
36.0										
37.0										
38.0										
39.0										
40.0										
41.0										
42.0										
43.0										
44.0										
45.0										
46.0										
47.0										
48.0										
49.0										
50.0										
51.0										
52.0										
53.0										
54.0										
55.0										
56.0										
57.0										
58.0										
59.0										
60.0										
61.0										
62.0										
63.0										
64.0										
65.0										
66.0										
67.0										
68.0										
69.0										
70.0										
71.0										
72.0										
73.0										
74.0										
75.0										
76.0										

1MP SOIL LOG GINT\_1037 CARP RD.GPJ MP\_OTTAWA\_FOUNDATIONS.GDT 22-10-14

GRAPH NOTES  
 30 Upper value = Field Vane Shear Strength ○ s=3%  
 3 Lower value = Vane Sensitivity Strain at Failure

PROJECT NO.: **OCP-19-0125**  
 PROJECT: Office Building  
 CLIENT: Jim Bell  
 PROJECT LOCATION: 1037 Carp Road

DRILLING DATA  
 Date: Oct-12-2022  
 Method: Hollow Stem Auger  
 Diameter: 200 mm  
 BH Location:

BH No: **22-2 MW**  
 DATUM:  
 ENCL NO.: 2

SOIL PROFILE		SAMPLES				DYNAMIC CONE PENETRATION RESISTANCE PLOT 20 40 60 80	PLASTIC LIMIT W <sub>p</sub>	NATURAL MOISTURE CONTENT w	LIQUID LIMIT W <sub>L</sub>	Remarks and Grain Size Distribution (%) Unit Weight (kN/m <sup>3</sup> ) Pocket Penetro. (kPa)
ELEV DEPTH	DESCRIPTION	STRATA PLOT NUMBER	TYPE	"N" BLOWS 0.3 m	GROUND WATER CONDITIONS DEPTH					
124.8	Granular Bedding									GR SA SI CL
0.0	<b>WELL INSTALLTION ONLY</b>									
1.0										
2.0										
3.0										
4.0										
5.0										
6.0										
7.0										
117.2										
7.6										

1MP SOIL LOG GINT\_1037 CARP RD.GPJ\_MP\_OTTAWA\_FOUNDATIONS.GDT 22-10-14

GRAPH NOTES

30 Upper value = Field Vane Shear Strength ○ s=3%  
 3 Lower value = Vane Sensitivity Strain at Failure

PROJECT NO.: **OCP-19-0125**  
 PROJECT: Office Building  
 CLIENT: Jim Bell  
 PROJECT LOCATION: 1037 Carp Road

DRILLING DATA  
 Date: Oct-12-2022  
 Method: Hollow Stem Auger  
 Diameter: 200 mm  
 BH Location:

BH No: **22-3 MW**  
 DATUM:  
 ENCL NO.: 3

SOIL PROFILE		SAMPLES				GROUND WATER CONDITIONS DEPTH	DYNAMIC CONE PENETRATION RESISTANCE PLOT				PLASTIC LIMIT w <sub>p</sub>	NATURAL MOISTURE CONTENT w	LIQUID LIMIT w <sub>L</sub>	Remarks and Grain Size Distribution (%)  Unit Weight (kN/m <sup>3</sup> ) Pocket Penetro. (kPa)
ELEV DEPTH	DESCRIPTION	STRATA PLOT NUMBER	TYPE	"N" BLOWS 0.3 m	SHEAR STRENGTH (kPa) Field, Shear Vane (x) & Sensitivity ● Quick Triaxial ○ Unconfined				WATER CONTENT (%)					
125.2	Granular Bedding													GR SA SI CL
0.0	<b>WELL INSTALLTION ONLY</b>													
125														
124														
123														
122														
121														
120														
119														
118														
117.7														
7.5														

1MP SOIL LOG GINT\_1037 CARP RD.GPJ\_MP\_OTTAWA\_FOUNDATIONS.GDT 22-10-14

GRAPH  
NOTES

30 Upper value = Field Vane Shear Strength ○ s=3%  
 3 Lower value = Vane Sensitivity Strain at Failure

## APPENDIX B – MONITORING WELL LOGS

PROJECT NO.: **OCP-19-0125**  
 PROJECT: Office Building  
 CLIENT: Jim Bell  
 PROJECT LOCATION: 1037 Carp Road

DRILLING DATA  
 Date: Oct-12-2022  
 Method: Hollow Stem Auger  
 Diameter: 200 mm  
 BH Location:

BH No: **22-1 MW**  
 DATUM:  
 ENCL NO.: 1

SOIL PROFILE		SAMPLES				DYNAMIC CONE PENETRATION RESISTANCE PLOT 20 40 60 80	PLASTIC LIMIT W <sub>p</sub>	NATURAL MOISTURE CONTENT w	LIQUID LIMIT W <sub>L</sub>	Remarks and Grain Size Distribution (%) Unit Weight (kN/m <sup>3</sup> ) Pocket Penetro. (kPa)
ELEV DEPTH	DESCRIPTION	STRATA PLOT NUMBER	TYPE	"N" BLOWS 0.3 m	GROUND WATER CONDITIONS DEPTH					
124.6	Granular Bedding									GR SA SI CL
0.0	<b>WELL INSTALLTION ONLY</b>									
1.0										
2.0										
3.0										
4.0										
5.0										
6.0										
7.0										
8.0										
9.0										
10.0										
11.0										
12.0										
13.0										
14.0										
15.0										
16.0										
17.0										
18.0										
19.0										
20.0										
21.0										
22.0										
23.0										
24.0										
25.0										
26.0										
27.0										
28.0										
29.0										
30.0										
31.0										
32.0										
33.0										
34.0										
35.0										
36.0										
37.0										
38.0										
39.0										
40.0										
41.0										
42.0										
43.0										
44.0										
45.0										
46.0										
47.0										
48.0										
49.0										
50.0										
51.0										
52.0										
53.0										
54.0										
55.0										
56.0										
57.0										
58.0										
59.0										
60.0										
61.0										
62.0										
63.0										
64.0										
65.0										
66.0										
67.0										
68.0										
69.0										
70.0										
71.0										
72.0										
73.0										
74.0										
75.0										
76.0										

1MP SOIL LOG GINT\_1037 CARP RD.GPJ MP\_OTTAWA\_FOUNDATIONS.GDT 22-10-14

GRAPH NOTES  
 30 Upper value = Field Vane Shear Strength ○ s=3%  
 3 Lower value = Vane Sensitivity Strain at Failure



PROJECT NO.: **OCP-19-0125**  
 PROJECT: Office Building  
 CLIENT: Jim Bell  
 PROJECT LOCATION: 1037 Carp Road

DRILLING DATA  
 Date: Oct-12-2022  
 Method: Hollow Stem Auger  
 Diameter: 200 mm  
 BH Location:

BH No: **22-2 MW**  
 DATUM:  
 ENCL NO.: 2

SOIL PROFILE		SAMPLES				GROUND WATER CONDITIONS	ELEVATION	DYNAMIC CONE PENETRATION RESISTANCE PLOT				PLASTIC NATURAL LIQUID LIMIT MOISTURE LIMIT			Remarks and Grain Size Distribution (%)  Unit Weight (kN/m <sup>3</sup> ) Pocket Penetro. (kPa)
ELEV DEPTH	DESCRIPTION	STRATA PLOT NUMBER	TYPE	"N" BLOWS 0.3 m	DEPTH			SHEAR STRENGTH (kPa)				W <sub>p</sub>	w	W <sub>L</sub>	
124.8	Granular Bedding														
0.0	<b>WELL INSTALLTION ONLY</b>														
1.0															
2.0															
3.0															
4.0															
5.0															
6.0															
7.0															
117.2															
7.6															

1MP SOIL LOG GINT\_1037 CARP RD.GPJ\_MP\_OTTAWA\_FOUNDATIONS.GDT 22-10-14

GRAPH  
NOTES

30 Upper value = Field Vane Shear Strength    ○ = 3%  
 3 Lower value = Vane Sensitivity                      Strain at Failure

PROJECT NO.: **OCP-19-0125**  
 PROJECT: Office Building  
 CLIENT: Jim Bell  
 PROJECT LOCATION: 1037 Carp Road

DRILLING DATA  
 Date: Oct-12-2022  
 Method: Hollow Stem Auger  
 Diameter: 200 mm  
 BH Location:

BH No: **22-3 MW**  
 DATUM:  
 ENCL NO.: 3

SOIL PROFILE		SAMPLES				GROUND WATER CONDITIONS DEPTH	DYNAMIC CONE PENETRATION RESISTANCE PLOT				PLASTIC LIMIT NATURAL MOISTURE CONTENT LIQUID LIMIT			Remarks and Grain Size Distribution (%)  Unit Weight (kN/m <sup>3</sup> ) Pocket Penetro. (kPa)
ELEV DEPTH	DESCRIPTION	STRATA PLOT NUMBER	TYPE	"N" BLOWS 0.3 m	20 40 60 80		20 40 60 80	20 40 60 80	20 40 60 80	W <sub>p</sub>	w	W <sub>L</sub>	GR SA SI CL	
125.2	Granular Bedding													
0.0	<b>WELL INSTALLTION ONLY</b>													
125														
124														
123														
122														
121														
120														
119														
118														
117.7														
7.5														

1MP SOIL LOG GINT\_1037 CARP RD.GPJ\_MP\_OTTAWA\_FOUNDATIONS.GDT 22-10-14

GRAPH  
NOTES

30 Upper value = Field Vane Shear Strength ○ s=3%  
 3 Lower value = Vane Sensitivity Strain at Failure

**APPENDIX E  
PRE-DEVELOPMENT DRAINAGE PLAN**

FILENAME: U:\Ottawa\01 - Project - Proposals\2019 jobs\CP\CP-Projects\CP-19-0125 - 5m Bell - Office Buildings\_1037 Carp Road\Civil\12 - Drawings\CP-19-0125 - Presentation.dwg  
 LAST PLOTTED: Friday, July 15, 2022 8:18 AM  
 USER: client

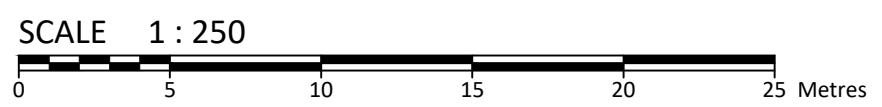
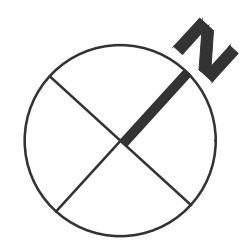
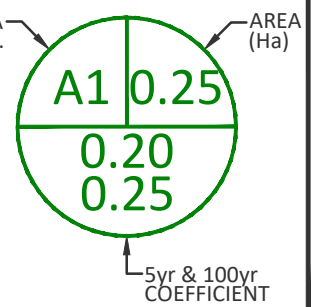
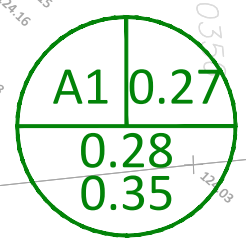

**McINTOSH PERRY**  
 115 Walgreen Road, RR3, Carp, ON K0A 1L0  
 Tel: 613-836-2184 Fax: 613-836-3742  
 www.mcintoshperry.com

Drawn by: B.G.S	Checked By: R.D.F
Scale: 1:250	Project Number: CP-19-0125

Client:	PROJECT 1 STUDIOS 300 - 260 ST. PATRICK STREET, OTTAWA, ON K1N 5K5		
Project:	PHASE 1 - OFFICE BUILDING 1037 CARP ROAD, OTTAWA, ON		
Drawing Title:	PRE-DEVELOPMENT DRAINAGE AREA PLAN		
No.	Revisions	Date	Drawing Number: <b>PRE</b>

**APPENDIX F**  
**POST-DEVELOPMENT DRAINAGE PLAN**

FILENAME: U:\Ottawa\01 - Projects - Proposals\2019 jobs\CP\CP-Projects\CP-19-0125 - Jim Bell - Office Buildings\_1037 Carp Road\Civil\12 - Drawings\CP-19-0125\_Presentation.dwg  
 LAST PLOTTED: Monday, November 28, 2022 11:17:41 AM  
 LAST FILE USED:

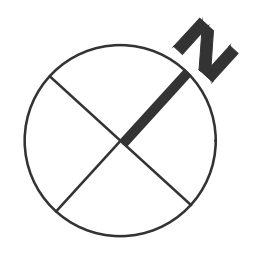
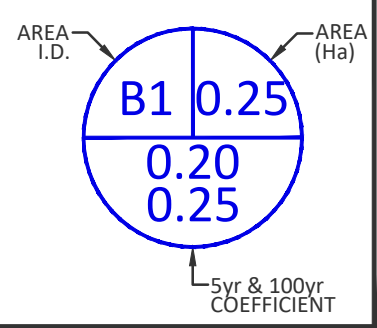
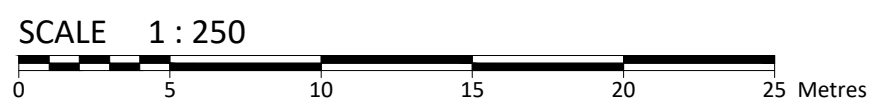
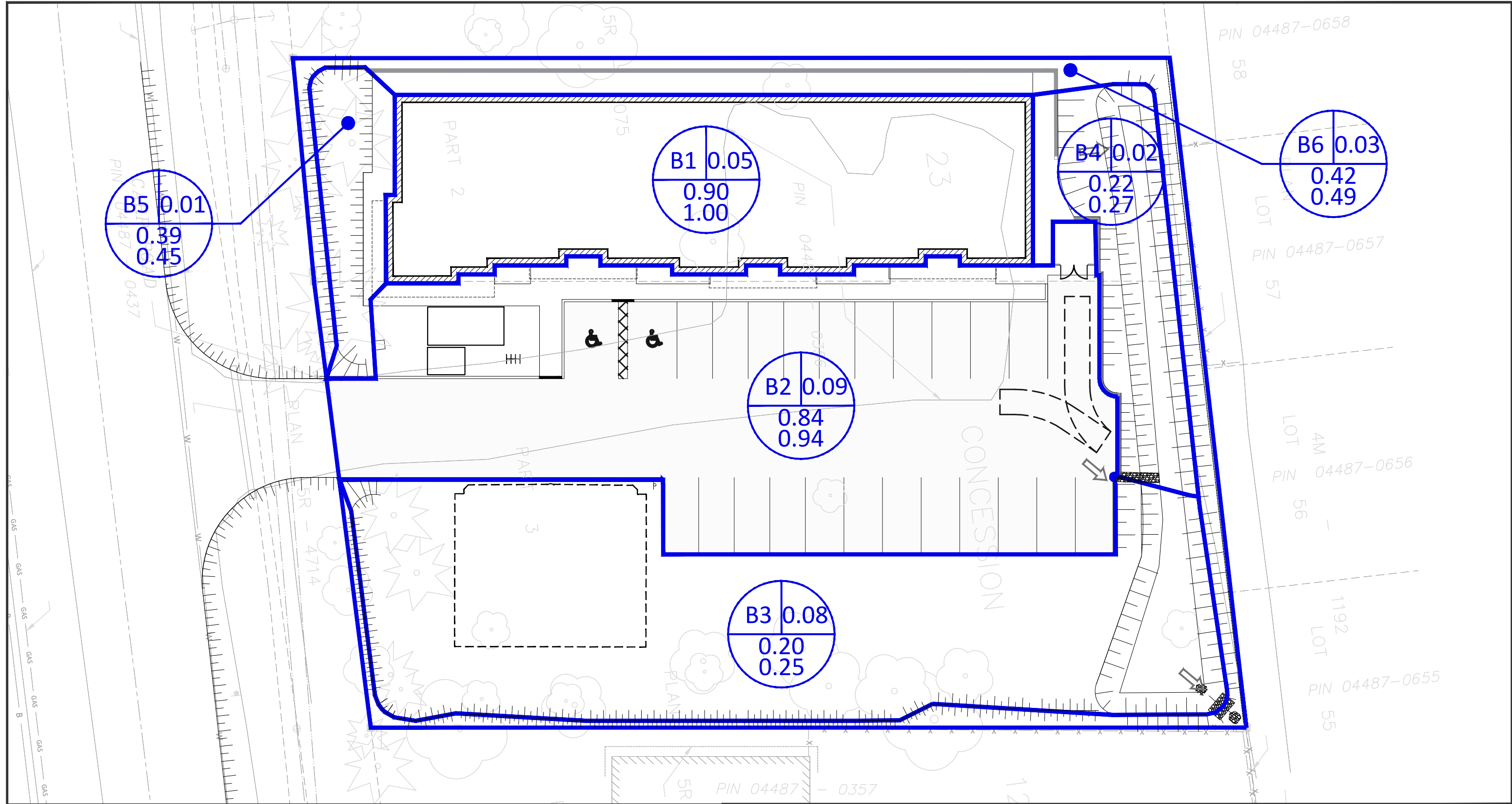

**McINTOSH PERRY**  
 115 Walgreen Road, RR3, Carp, ON K0A 1L0  
 Tel: 613-836-2184 Fax: 613-836-3742  
 www.mcintoshperry.com

Drawn by: B.G.S	Checked By: R.D.F
Scale: 1:250	Project Number: CP-19-0125

Client: <b>PROJECT 1 STUDIOS</b> 300 - 260 ST. PATRICK STREET, OTTAWA, ON K1N 5K5	
Project: <b>PHASE 1 - OFFICE BUILDING</b> 1037 CARP ROAD, OTTAWA, ON	
Drawing Title: <b>POST-DEVELOPMENT DRAINAGE AREA PLAN</b>	
1	REVISED PER CITY COMMENTS
No.	Revisions
	Date
	2022.11.28
Drawing Number: <b>POST</b>	

**APPENDIX G**  
**STORMWATER MANAGEMENT CALCULATIONS**



# McINTOSH PERRY

## CP-19-0125 - 1037 Carp Road - SWM Design

1 of 4

### Pre-Development Runoff Coefficient

Drainage Area	Area (ha)	Impervious Area (m <sup>2</sup> )	C	Gravel Area (m <sup>2</sup> )	C	Pervious Area (m <sup>2</sup> )	C	C <sub>AVG</sub> 5-Year	C <sub>AVG</sub> 100-Year
A1	0.27	0.00	0.90	537.89	0.60	2,167.79	0.20	0.28	0.35

### Pre-Development Runoff Calculations

Drainage Area	Area (ha)	C 28.5-Year	C 100-Year	Tc (min)	I (mm/hr)		Q (L/s)	
					5-Year	100-Year	5-Year	100-Year
					A1	0.27	0.28	0.35
Total	0.27						21.91	46.93

### Post-Development Runoff Coefficient

Drainage Area	Area (ha)	Impervious Area (m <sup>2</sup> )	C	Gravel Area (m <sup>2</sup> )	C	Pervious Area (m <sup>2</sup> )	C	C <sub>AVG</sub> 5-Year	C <sub>AVG</sub> 100-Year	
B1	0.05	513.92	0.90	0.00	0.60	0.00	0.20	0.90	1.00	Roof
B2	0.09	822.26	0.90	0.00	0.60	70.72	0.20	0.84	0.94	Parking
B3	0.08	0.00	0.90	0.00	0.60	775.47	0.20	0.20	0.25	Restricted
B4	0.02	6.27	0.90	0.00	0.60	182.72	0.20	0.22	0.27	Restricted
B5	0.01	22.34	0.90	0.00	0.60	61.97	0.20	0.39	0.45	Restricted
B6	0.03	79.96	0.90	0.00	0.60	170.62	0.20	0.42	0.49	Unrestricted
Total	0.27									

### Post-Development Runoff Calculations

Drainage Area	Area (ha)	C 5-Year	C 100-Year	Tc (min)	I (mm/hr)		Q (L/s)	
					5-Year	100-Year	5-Year	100-Year
					B1	0.05	0.90	1.00
B2	0.09	0.84	0.94	10	104.2	178.6	21.85	41.69
B3	0.08	0.20	0.25	10	104.2	178.6	4.49	9.62
B4	0.02	0.22	0.27	10	104.2	178.6	1.22	2.58
B5	0.01	0.39	0.45	10	104.2	178.6	0.94	1.88
B6	0.03	0.42	0.49	10	104.2	178.6	3.07	6.09
Total	0.27						44.97	87.37

# McINTOSH PERRY

## CP-19-0125 - 1037 Carp Road - SWM Design

### Required Restricted Flow

Drainage Area	Area (ha)	C 5-Year	C 100-Year	Tc (min)	I (mm/hr)		Q (L/s)	
					5-Year	100-Year	5-Year	100-Year
Total	0.27	0.28	0.35	10	104.2	178.6	21.91	46.93

Post-development 5 & 100-year flows to match pre-development 5 & 100-year flows

### Post-Development Restricted Runoff Calculations

Drainage Area	Unrestricted Flow (L/s)		Restricted Flow (L/s)		Storage Required (m <sup>3</sup> )		Storage Provided (m <sup>3</sup> )	
	5-Year	100-Year	5-Year	100-Year	5-Year	100-Year	5-Year	100-Year
B1	13.40	25.51	18.49	34.63	14.10	28.21	14.22	31.05
B2	21.85	41.69						
B3	4.49	9.62						
B4	1.22	2.58						
B5	0.94	1.88						
B6	3.07	6.09	3.07	6.09				
Total	44.97	87.37	21.56	40.72				

# McINTOSH PERRY

## CP-19-0125 - 1037 Carp Road - Site Storage

### Storage Requirements for Areas B2-B7

#### 5-Year Storm Event

Tc (min)	I (mm/hr)	B1 Runoff (L/s)	B2 Runoff (L/s)	B3 Runoff (L/s)	B4 Runoff (L/s)	B5 Runoff (L/s)	Allowable Outflow (L/s)	Runoff to be Stored (L/s)	Storage Required (m <sup>3</sup> )
10	104.2	13.40	21.85	4.49	1.22	0.94	18.49	23.41	14.05
12	94.7	12.18	19.85	4.08	1.11	0.86	18.49	19.59	14.10
14	86.9	11.18	18.23	3.75	1.02	0.79	18.49	16.47	13.83
16	80.5	10.35	16.87	3.47	0.94	0.73	18.49	13.86	13.31
18	75.0	9.64	15.72	3.23	0.88	0.68	18.49	11.66	12.59
20	70.25	9.03	14.73	3.03	0.82	0.63	18.49	9.76	11.71
22	66.1	8.51	13.87	2.85	0.78	0.60	18.49	8.11	10.70
24	62.5	8.04	13.11	2.70	0.73	0.57	18.49	6.66	9.59
26	59.3	7.63	12.44	2.56	0.70	0.54	18.49	5.37	8.38

Maximum Storage Required 5-Year (m<sup>3</sup>) = 14.10

#### 100-Year Storm Event

Tc (min)	I (mm/hr)	B1 Runoff (L/s)	B2 Runoff (L/s)	B3 Runoff (L/s)	B4 Runoff (L/s)	B5 Runoff (L/s)	Allowable Outflow (L/s)	Runoff to be Stored (L/s)	Storage Required (m <sup>3</sup> )
10	178.6	25.51	41.69	9.62	2.58	1.88	34.63	46.66	27.99
12	162.1	23.16	37.86	8.74	2.34	1.71	34.63	39.18	28.21
14	148.7	21.25	34.73	8.02	2.15	1.56	34.63	33.07	27.78
16	137.5	19.65	32.12	7.41	1.99	1.45	34.63	27.99	26.87
18	128.1	18.30	29.91	6.90	1.85	1.35	34.63	23.68	25.57
20	120.0	17.14	28.01	6.46	1.73	1.26	34.63	19.97	23.97
22	112.9	16.13	26.36	6.08	1.63	1.19	34.63	16.76	22.12
24	106.7	15.24	24.91	5.75	1.54	1.12	34.63	13.93	20.06
26	101.2	14.46	23.63	5.45	1.46	1.06	34.63	11.43	17.83
28	96.3	13.75	22.48	5.19	1.39	1.01	34.63	9.20	15.45

Maximum Storage Required 100-Year (m<sup>3</sup>) = 28.21

#### 5-Year Storm Event Storage Summary

	Water Elev. (m) =		123.03		
Location	INV. (out)	Area (m <sup>2</sup> )	Depth (m)	Head (m)	Volume (m <sup>3</sup> )
Depressed Storage Area	122.80	126.4	0.23	0.23	14.2

Storage Available (m<sup>3</sup>) = 14.2 \*

Storage Required (m<sup>3</sup>) = 14.1

#### 100-Year Storm Event Storage Summary

	Water Elev. (m) =		123.16		
Location	INV. (out)	Area (m <sup>2</sup> )	Depth (m)	Head (m)	Volume (m <sup>3</sup> )
Depressed Storage Area	122.80	161.0	0.36	0.36	31.5

Storage Available (m<sup>3</sup>) = 31.1 \*

Storage Required (m<sup>3</sup>) = 28.2

\* Available Storage calculated from AutoCAD

# McINTOSH PERRY

## CP-19-0125 - 1037 Carp Road - Outlet Control Device

For Orifice Flow, C= 0.60  
 For Weir Flow, C= 1.84

	Orifice 1	Orifice 2	Weir 1	Weir 2
invert elevation	122.80	X	123.13	X
center of crest elevation	122.88	X	X	X
orifice width / weir length	150 mm	X	1.00 m	X
weir height				X
orifice area (m <sup>2</sup> )	0.018	X	x	X

Elevation Discharge Table - Storm Routing

Elevation	Orifice 1		Orifice 2		Weir 1		Weir 2		Total
	H [m]	Q [m <sup>3</sup> /s]	H [m]	Q [m <sup>3</sup> /s]	H [m]	Q [m <sup>3</sup> /s]	H [m]	Q [m <sup>3</sup> /s]	
122.85	x	x	x	x	x	x	x	x	0.0
122.86	x	x	x	x	x	x	x	x	0.0
122.87	x	x	x	x	x	x	x	x	0.0
122.88	0.01	0.003	x	x	x	x	x	x	3.3
122.89	0.02	0.006	x	x	x	x	x	x	5.8
122.90	0.03	0.007	x	x	x	x	x	x	7.4
122.91	0.04	0.009	x	x	x	x	x	x	8.8
122.92	0.05	0.010	x	x	x	x	x	x	10.0
122.93	0.06	0.011	x	x	x	x	x	x	11.0
122.94	0.07	0.012	x	x	x	x	x	x	12.0
122.95	0.08	0.013	x	x	x	x	x	x	12.9
122.96	0.09	0.014	x	x	x	x	x	x	13.7
122.97	0.10	0.014	x	x	x	x	x	x	14.5
122.98	0.11	0.015	x	x	x	x	x	x	15.2
122.99	0.12	0.016	x	x	x	x	x	x	15.9
123.00	0.13	0.017	x	x	x	x	x	x	16.6
123.01	0.14	0.017	x	x	x	x	x	x	17.3
123.02	0.15	0.018	x	x	x	x	x	x	17.9
123.03	0.16	0.018	x	x	x	x	x	x	18.49
123.04	0.17	0.019	x	x	x	x	x	x	19.08
123.05	0.18	0.020	x	x	x	x	x	x	19.6
123.06	0.19	0.020	x	x	x	x	x	x	20.2
123.07	0.20	0.021	x	x	x	x	x	x	20.7
123.08	0.21	0.021	x	x	x	x	x	x	21.3
123.09	0.22	0.022	x	x	x	x	x	x	21.8
123.10	0.23	0.022	x	x	x	x	x	x	22.3
123.11	0.24	0.023	x	x	x	x	x	x	22.8
123.12	0.25	0.023	x	x	x	x	x	x	23.2
123.13	0.26	0.024	x	x	x	x	x	x	23.7
123.14	0.27	0.024	x	x	0.01	0.00	x	x	26.0
123.15	0.28	0.025	x	x	0.02	0.01	x	x	29.8
123.16	0.29	0.025	x	x	0.03	0.01	x	x	34.63
123.17	0.30	0.026	x	x	0.04	0.01	x	x	40.2
123.18	0.31	0.026	x	x	0.05	0.02	x	x	46.5

5-Year

100-Year

- Notes:
1. For Orifice Flow, User is to Input an Elevation Higher than Crown of Orifice.
  2. Orifice Equation:  $Q = cA(2gh)^{1/2}$
  3. Weir Equation:  $Q = CLH^{3/2}$
  4. These Computations Do Not Account for Submergence Effects Within the Pond Riser.
  5. H for orifice equations is depth of water above the centroid of the orifice.
  6. H for weir equations is depth of water above the weir crest.

**APPENDIX H**  
**CITY OF OTTAWA DESIGN CHECKLIST**

# City of Ottawa

## 4. Development Servicing Study Checklist

The following section describes the checklist of the required content of servicing studies. It is expected that the proponent will address each one of the following items for the study to be deemed complete and ready for review by City of Ottawa Infrastructure Approvals staff.

The level of required detail in the Servicing Study will increase depending on the type of application. For example, for Official Plan amendments and re-zoning applications, the main issues will be to determine the capacity requirements for the proposed change in land use and confirm this against the existing capacity constraint, and to define the solutions, phasing of works and the financing of works to address the capacity constraint. For subdivisions and site plans, the above will be required with additional detailed information supporting the servicing within the development boundary.

### 4.1 General Content

Criteria	Location (if applicable)
<input type="checkbox"/> Executive Summary (for larger reports only).	N/A
<input type="checkbox"/> Date and revision number of the report.	On Cover
<input type="checkbox"/> Location map and plan showing municipal address, boundary, and layout of proposed development.	Appendix A
<input type="checkbox"/> Plan showing the site and location of all existing services.	Site Servicing Plan (C102)
<input type="checkbox"/> Development statistics, land use, density, adherence to zoning and official plan, and reference to applicable subwatershed and watershed plans that provide context to which individual developments must adhere.	1.1 Purpose 1.2 Site Description 6.0 Stormwater Management
<input type="checkbox"/> Summary of pre-consultation meetings with City and other approval agencies.	Appendix B
<input type="checkbox"/> Reference and confirm conformance to higher level studies and reports (Master Servicing Studies, Environmental Assessments, Community Design Plans), or in the case where it is not in conformance, the proponent must provide justification and develop a defensible design criteria.	1.1 Purpose 1.2 Site Description 6.0 Stormwater Management
<input type="checkbox"/> Statement of objectives and servicing criteria.	3.0 Pre-Consultation Summary

<input type="checkbox"/> Identification of existing and proposed infrastructure available in the immediate area.	N/A
<input type="checkbox"/> Identification of Environmentally Significant Areas, watercourses and Municipal Drains potentially impacted by the proposed development (Reference can be made to the Natural Heritage Studies, if available).	Site Grading Plan (C101)
<input type="checkbox"/> Concept level master grading plan to confirm existing and proposed grades in the development. This is required to confirm the feasibility of proposed stormwater management and drainage, soil removal and fill constraints, and potential impacts to neighbouring properties. This is also required to confirm that the proposed grading will not impede existing major system flow paths.	N/A
<input type="checkbox"/> Identification of potential impacts of proposed piped services on private services (such as wells and septic fields on adjacent lands) and mitigation required to address potential impacts.	N/A
<input type="checkbox"/> Proposed phasing of the development, if applicable.	N/A
<input type="checkbox"/> Reference to geotechnical studies and recommendations concerning servicing.	Section 2.0 Background Studies, Standards and References
<input type="checkbox"/> All preliminary and formal site plan submissions should have the following information: <ul style="list-style-type: none"> <li>○ Metric scale</li> <li>○ North arrow (including construction North)</li> <li>○ Key plan</li> <li>○ Name and contact information of applicant and property owner</li> <li>○ Property limits including bearings and dimensions</li> <li>○ Existing and proposed structures and parking areas</li> <li>○ Easements, road widening and rights-of-way</li> <li>○ Adjacent street names</li> </ul>	Site Grading Plan (C101)

## 4.2 Development Servicing Report: Water

Criteria	Location (if applicable)
<input type="checkbox"/> Confirm consistency with Master Servicing Study, if available	N/A
<input type="checkbox"/> Availability of public infrastructure to service proposed development	N/A
<input type="checkbox"/> Identification of system constraints	N/A
<input type="checkbox"/> Identify boundary conditions	Appendix C
<input type="checkbox"/> Confirmation of adequate domestic supply and pressure	N/A
<input type="checkbox"/> Confirmation of adequate fire flow protection and confirmation that fire flow is calculated as per the Fire Underwriter’s Survey. Output should show available fire flow at locations throughout the development.	Appendix C
<input type="checkbox"/> Provide a check of high pressures. If pressure is found to be high, an assessment is required to confirm the application of pressure reducing valves.	N/A
<input type="checkbox"/> Definition of phasing constraints. Hydraulic modeling is required to confirm servicing for all defined phases of the project including the ultimate design	N/A
<input type="checkbox"/> Address reliability requirements such as appropriate location of shut-off valves	N/A
<input type="checkbox"/> Check on the necessity of a pressure zone boundary modification.	N/A
<input type="checkbox"/> Reference to water supply analysis to show that major infrastructure is capable of delivering sufficient water for the proposed land use. This includes data that shows that the expected demands under average day, peak hour and fire flow conditions provide water within the required pressure range	Appendix C, Section 4.2



<input type="checkbox"/> Description of the proposed water distribution network, including locations of proposed connections to the existing system, provisions for necessary looping, and appurtenances (valves, pressure reducing valves, valve chambers, and fire hydrants) including special metering provisions.	Site Servicing Plan (C101)
<input type="checkbox"/> Description of off-site required feeder mains, booster pumping stations, and other water infrastructure that will be ultimately required to service proposed development, including financing, interim facilities, and timing of implementation.	N/A
<input type="checkbox"/> Confirmation that water demands are calculated based on the City of Ottawa Design Guidelines.	Appendix C
<input type="checkbox"/> Provision of a model schematic showing the boundary conditions locations, streets, parcels, and building locations for reference.	N/A

#### 4.3 Development Servicing Report: Wastewater

Criteria	Location (if applicable)
<input type="checkbox"/> Summary of proposed design criteria (Note: Wet-weather flow criteria should not deviate from the City of Ottawa Sewer Design Guidelines. Monitored flow data from relatively new infrastructure cannot be used to justify capacity requirements for proposed infrastructure).	N/A
<input type="checkbox"/> Confirm consistency with Master Servicing Study and/or justifications for deviations.	N/A
<input type="checkbox"/> Consideration of local conditions that may contribute to extraneous flows that are higher than the recommended flows in the guidelines. This includes groundwater and soil conditions, and age and condition of sewers.	N/A
<input type="checkbox"/> Description of existing sanitary sewer available for discharge of wastewater from proposed development.	Section 5.1 Existing Sanitary Sewer

<input type="checkbox"/> Verify available capacity in downstream sanitary sewer and/or identification of upgrades necessary to service the proposed development. (Reference can be made to previously completed Master Servicing Study if applicable)	N/A
<input type="checkbox"/> Calculations related to dry-weather and wet-weather flow rates from the development in standard MOE sanitary sewer design table (Appendix 'C') format.	N/A
<input type="checkbox"/> Description of proposed sewer network including sewers, pumping stations, and forcemains.	Section 5.2 Proposed Sanitary Sewer
<input type="checkbox"/> Discussion of previously identified environmental constraints and impact on servicing (environmental constraints are related to limitations imposed on the development in order to preserve the physical condition of watercourses, vegetation, soil cover, as well as protecting against water quantity and quality).	N/A
<input type="checkbox"/> Pumping stations: impacts of proposed development on existing pumping stations or requirements for new pumping station to service development.	N/A
<input type="checkbox"/> Forcemain capacity in terms of operational redundancy, surge pressure and maximum flow velocity.	N/A
<input type="checkbox"/> Identification and implementation of the emergency overflow from sanitary pumping stations in relation to the hydraulic grade line to protect against basement flooding.	N/A
<input type="checkbox"/> Special considerations such as contamination, corrosive environment etc.	N/A

#### 4.4 Development Servicing Report: Stormwater Checklist

Criteria	Location (if applicable)
<input type="checkbox"/> Description of drainage outlets and downstream constraints including legality of outlets (i.e. municipal drain, right-of-way, watercourse, or private property)	Section 6.0 Stormwater Sewer Design & Section 7.0 Proposed Stormwater Management
<input type="checkbox"/> Analysis of available capacity in existing public infrastructure.	N/A
<input type="checkbox"/> A drawing showing the subject lands, its surroundings, the receiving watercourse, existing drainage patterns, and proposed drainage pattern.	Pre & Post-Development Plans
<input type="checkbox"/> Water quantity control objective (e.g. controlling post-development peak flows to pre-development level for storm events ranging from the 2 or 5-year event (dependent on the receiving sewer design) to 100-year return period); if other objectives are being applied, a rationale must be included with reference to hydrologic analyses of the potentially affected subwatersheds, taking into account long-term cumulative effects.	Section 6.0 Stormwater Sewer Design & Section 7.0 Proposed Stormwater Management
<input type="checkbox"/> Water Quality control objective (basic, normal or enhanced level of protection based on the sensitivities of the receiving watercourse) and storage requirements.	Section 6.0 Stormwater Sewer Design & Section 7.0 Proposed Stormwater Management
<input type="checkbox"/> Description of the stormwater management concept with facility locations and descriptions with references and supporting information.	Section 6.0 Stormwater Sewer Design & Section 7.0 Proposed Stormwater Management
<input type="checkbox"/> Set-back from private sewage disposal systems.	N/A
<input type="checkbox"/> Watercourse and hazard lands setbacks.	N/A
<input type="checkbox"/> Record of pre-consultation with the Ontario Ministry of Environment and the Conservation Authority that has jurisdiction on the affected watershed.	N/A
<input type="checkbox"/> Confirm consistency with sub-watershed and Master Servicing Study, if applicable study exists.	N/A
<input type="checkbox"/> Storage requirements (complete with calculations) and conveyance capacity for minor events (1:5-year return period) and major events (1:100-year return period).	Appendix G

<input type="checkbox"/> Identification of watercourses within the proposed development and how watercourses will be protected, or, if necessary, altered by the proposed development with applicable approvals.	Site Grading Plan
<input type="checkbox"/> Calculate pre-and post development peak flow rates including a description of existing site conditions and proposed impervious areas and drainage catchments in comparison to existing conditions.	Section 7.0 Proposed Stormwater Management Appendix G
<input type="checkbox"/> Any proposed diversion of drainage catchment areas from one outlet to another.	Section 6.0 Stormwater Sewer Design & Section 7.0 Proposed Stormwater Management
<input type="checkbox"/> Proposed minor and major systems including locations and sizes of stormwater trunk sewers, and stormwater management facilities.	Section 6.0 Stormwater Sewer Design & Section 7.0 Proposed Stormwater Management
<input type="checkbox"/> If quantity control is not proposed, demonstration that downstream system has adequate capacity for the post-development flows up to and including the 100-year return period storm event.	N/A
<input type="checkbox"/> Identification of potential impacts to receiving watercourses	N/A
<input type="checkbox"/> Identification of municipal drains and related approval requirements.	N/A
<input type="checkbox"/> Descriptions of how the conveyance and storage capacity will be achieved for the development.	Section 6.0 Stormwater Sewer Design & Section 7.0 Proposed Stormwater Management
<input type="checkbox"/> 100-year flood levels and major flow routing to protect proposed development from flooding for establishing minimum building elevations (MBE) and overall grading.	Site Grading Plan (C101)
<input type="checkbox"/> Inclusion of hydraulic analysis including hydraulic grade line elevations.	N/A

<input type="checkbox"/> Description of approach to erosion and sediment control during construction for the protection of receiving watercourse or drainage corridors.	Section 8.0 Sediment & Erosion Control
<input type="checkbox"/> Identification of floodplains – proponent to obtain relevant floodplain information from the appropriate Conservation Authority. The proponent may be required to delineate floodplain elevations to the satisfaction of the Conservation Authority if such information is not available or if information does not match current conditions.	N/A
<input type="checkbox"/> Identification of fill constraints related to floodplain and geotechnical investigation.	N/A

#### 4.5 Approval and Permit Requirements: Checklist

The Servicing Study shall provide a list of applicable permits and regulatory approvals necessary for the proposed development as well as the relevant issues affecting each approval. The approval and permitting shall include but not be limited to the following:

Criteria	Location (if applicable)
<input type="checkbox"/> Conservation Authority as the designated approval agency for modification of floodplain, potential impact on fish habitat, proposed works in or adjacent to a watercourse, cut/fill permits and Approval under Lakes and Rivers Improvement Act. The Conservation Authority is not the approval authority for the Lakes and Rivers Improvement Act. Where there are Conservation Authority regulations in place, approval under the Lakes and Rivers Improvement Act is not required, except in cases of dams as defined in the Act.	N/A
<input type="checkbox"/> Application for Certificate of Approval (CofA) under the Ontario Water Resources Act.	N/A
<input type="checkbox"/> Changes to Municipal Drains.	N/A
<input type="checkbox"/> Other permits (National Capital Commission, Parks Canada, Public Works and Government Services Canada, Ministry of Transportation etc.)	N/A

## 4.6 Conclusion Checklist

Criteria	Location (if applicable)
<input type="checkbox"/> Clearly stated conclusions and recommendations	Section 9.0 Summary  Section 10.0 Recommendations
<input type="checkbox"/> Comments received from review agencies including the City of Ottawa and information on how the comments were addressed. Final sign-off from the responsible reviewing agency.	All are stamped
<input type="checkbox"/> All draft and final reports shall be signed and stamped by a professional Engineer registered in Ontario	All are stamped