

CITY OF OTTAWA

2262 BRAESIDE AVENUE TRANSPORTATION IMPACT ASSESSMENT DRAFT FINAL REPORT

MAY 02, 2022

DRAFT

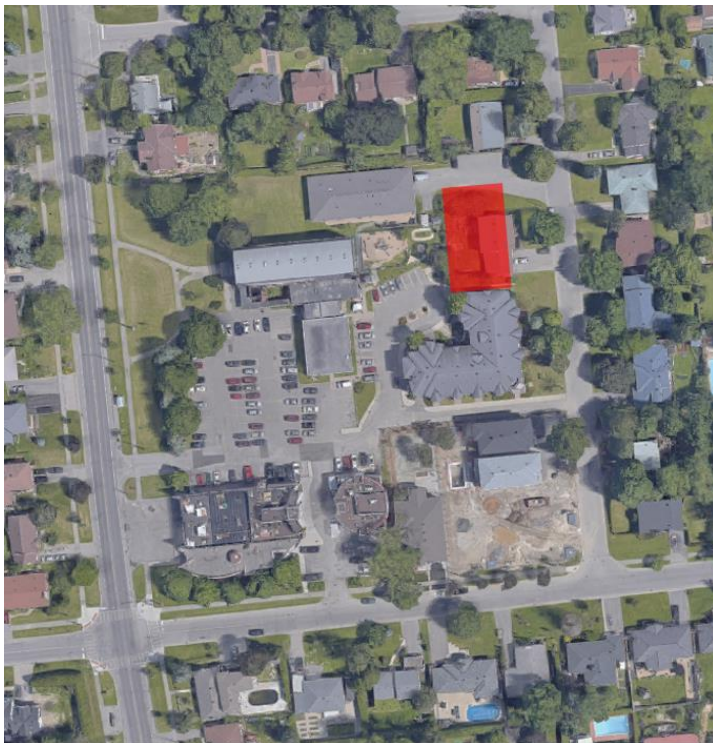



2262 BRAESIDE
AVENUE
TRANSPORTATION
IMPACT ASSESSMENT
DRAFT FINAL REPORT
CITY OF OTTAWA

DRAFT

PROJECT NO.: OUR REF. NO. 20M-01221-00
DATE: MAY 02, 2022

WSP
SUITE 300
2611 QUEENSVIEW DRIVE
OTTAWA, ON, CANADA K2B 8K2

T: +1 613 829-2800
F: +1 613 829-8299
WSP.COM



TABLE OF CONTENTS

1	SCREENING	1
2	SCOPING.....	2
2.1	Screening Form	2
2.2	Description of Proposed Development.....	2
2.3	Existing Conditions.....	3
2.3.1	Roadways and Pedestrian / Cycling Facilities.....	3
2.3.2	Intersections	4
2.3.3	Driveways	4
2.3.4	Transit Facilities	4
2.3.5	Area Traffic Management Measures.....	5
2.3.6	Peak Hour Travel Demands	5
2.3.7	Five-year Collision History	5
2.4	Planned Conditions.....	6
2.4.1	Changes to the Study Area Transportation Network.....	6
2.4.2	Other Study Area Developments.....	6
2.5	Study Area.....	6
2.6	Time Period	6
2.7	Horizon Years	7
2.8	Exemptions Review.....	7
3	FORECASTING	8
3.1	Development-Generated Travel Demand.....	8
3.1.1	Trip Generation	8
3.1.2	Trip Distribution	10
3.1.3	Trip Assignment	10
3.2	Background Network Traffic	11
3.3	Demand Rationalization.....	11
4	STRATEGY	12
4.1	Development Design.....	12
4.1.1	Design for sustainable modes	12

4.1.2	Circulation and Access	12
4.1.3	New Street Networks	13
4.2	Parking	13
4.2.1	Parking Supply	13
4.2.2	Spillover Parking	14
4.3	Boundary Streets	15
4.3.1	Alta Vista Drive	15
4.3.2	Braeside Avenue	16
4.4	Access Intersection	17
4.4.1	Location and Design of Access	17
4.4.2	INtersection Control	18
4.4.3	Intersection Design	19
4.5	Transportation Demand Management.....	19
4.5.1	Context for TDM	19
4.5.2	Need and Opportunity	20
4.5.3	TDM Program	20
4.6	Neighbourhood Traffic Management	20
4.7	Transit.....	20
4.8	Review of Network Concept.....	20
4.9	Intersection Design	20
4.10	Summary of Improvements Indicated and Modification Options.....	21

TABLES

TABLE 1-1. TRANSPORTATION IMPACT ASSESSMENT (TIA) SCREENING TRIGGERS	1
TABLE 2-1. EXISTING MODE SHARE – ALTA VISTA DISTRICT (LOW-RISE MULTIFAMILY HOUSING)	5
TABLE 2-2. FIVE YEAR COLLISION HISTORY SUMMARY	5
TABLE 2-3. EXEMPTIONS SUMMARY.....	7
TABLE 3-1. ESTIMATED TOTAL DEVELOPMENT- GENERATED PERSON-TRIPS (MULTI-UNIT LOW-RISE)	8

TABLE 3-2. DIRECTIONAL SPLITS (MULTI-UNIT LOW-RISE)	8
TABLE 3-3. EXISTING MODE SHARE.....	9
TABLE 3-4. FUTURE TRAVEL MODE SHARE TARGETS	9
TABLE 3-5. TRIPS GENERATED BY MODE	9
TABLE 3-6. TRIP DISTRIBUTION	10
TABLE 4-1. SWEEPED PATH ASSESSMENT.....	12
TABLE 4-2. MINIMUM BY-LAW REQUIREMENTS FOR VEHICULAR PARKING AND PROPOSED PARKING SUPPLY	13
TABLE 4-3. MINIMUM BY-LAW REQUIREMENTS FOR BICYCLE PARKING AND PROPOSED PARKING SUPPLY	14
TABLE 4-4. SEGMENT MMLOS - ALTA VISTA DRIVE	15
TABLE 4-5. SEGMENT MMLOS - BRAESIDE AVENUE	16
TABLE 4-6. ACCESS INTERSECTION DESIGN ELEMENTS	17
TABLE 4-7. ALL-WAY STOP (MINOR ROAD) REQUIREMENTS.....	18

FIGURES

FIGURE 2-1. AREA CONTEXT PLAN	2
FIGURE 2-2: BICYCLE AND PEDESTRIAN FACILITIES	3
FIGURE 2-3: OC TRANSPOR BUS ROUTES	4
FIGURE 2-4: STUDY AREA.....	6
FIGURE 3-1. VEHICLE TRIPS GENERATED BY DEVELOPMENT.....	10
FIGURE 4-1. ALTA VISTA DRIVE - EXISTING CROSS-SECTION	15
FIGURE 4-2. BRAESIDE AVENUE - EXISTING CROSS-SECTION.....	16
FIGURE 4-3. CITY OF OTTAWA, STANDARD DRAWING SC 7.1 CURB RETURN ENTRANCES, PRIVATE/UNSIGNALIZED (MARCH 2017).....	19

APPENDICES

A CIRCULATION COMMENT / RESPONSE



B	SCREENING FORM
C	DRAFT SITE PLAN
D	TRANS O-D SURVEY
E	DEVELOPMENT DESIGN CHECKLIST
F	AUTOTURN ANALYSIS
G	MMLOS SEGMENT CALCULATIONS
H	TDM CHECKLIST

1 SCREENING

This Transportation Impact Assessment (TIA) has been prepared to support the Site Plan Control Application and Zoning By-law Amendment for the development at 2262 Braeside in Ottawa. The TIA follows the City of Ottawa guidelines which potentially includes five steps:

- 1 Screening
- 2 Scoping
- 3 Forecasting
- 4 Analysis
- 5 TIA Report

The Screening Step determines the need to continue with a TIA Study. The development is assessed against three triggers: trip generation, location, and safety to identify the next step of the study. If one or more of the triggers is satisfied, the Scoping Step must be completed. If none of the triggers are satisfied, the TIA is deemed complete. If one or more triggers are satisfied, specific TIA components are required to be carried out depending on the combination of triggers (**Table 1-1**) that have been satisfied.

The proposed development at 2262 Braeside **satisfied the Location and Safety triggers** indicating that, as part of Steps Two through Five of the TIA process, the Design Review and Network Impact components should be completed. For reference, the completed Screening Form is provided in **Appendix B**.

Table 1-1. Transportation Impact Assessment (TIA) Screening Triggers

Next Step of the TIA Process	TIA TRIGGERS SATISFIED		
	Trip Generation	Location	Safety
<i>Design Review and Network Impact</i>	No	Yes	Yes

2 SCOPING

2.1 SCREENING FORM

The completed Screening Form is provided in **Appendix B**.

2.2 DESCRIPTION OF PROPOSED DEVELOPMENT

This Transportation Impact Assessment (TIA) has been prepared in support of the Zoning By-law Amendment and Site Plan Control Applications for the proposed development at 2262 Braeside Avenue in Ottawa, which represents a proposed extension to the existing Ellwood House retirement home at 2270 Braeside Avenue. The extension is located midblock on Braeside Avenue between Randall Avenue and Clontarf Avenue.

The property shares access points with St. Thomas The Apostle Church and Nursery School and Ottawa Fire Station 35. The property is currently zoned as a Minor Institutional Zone (I1A), Subzone A Urban Exception 1485 (I1A[1485]). **Figure 2-1** illustrates the Study Area Context.

The development information, as stated in the draft site plan attached as **Appendix C**, states that 38 new units will be built along with a net increase of 27 parking spaces in the shared parking lot with St. Thomas Church and School. As part of the Zoning By-law Amendment, parking requirements for the proposed development and other existing uses on the St. Thomas campus are proposed to be redistributed throughout reconfigured parking lots.

Two of the three existing site accesses will remain as the access/egress points to the proposed development. Both the accesses on Alta Vista Drive and Randall Avenue will remain, while the existing access on Braeside Avenue will be converted to allow for only egress. Additionally, one new access is being proposed on Alta Vista Drive, along with a realignment of an existing access on Braeside Avenue that will be for ingress only. It should be noted that the access on Randall Avenue requires the vehicles to cross through Ottawa Fire Station 35's parking lot (not the fire access).

The facility will be built as a single phase beginning in Spring 2023 with occupancy expected in 2024.

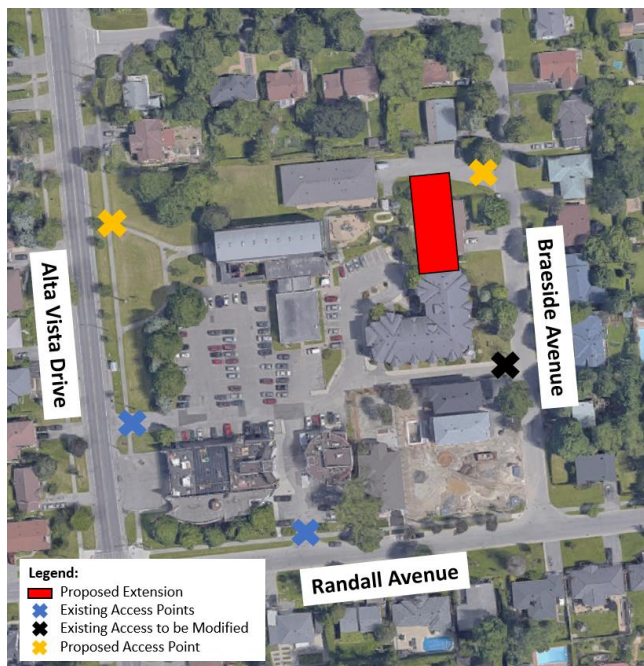

Figure 2-1. Area Context Plan

2.3 EXISTING CONDITIONS

2.3.1 ROADWAYS AND PEDESTRIAN / CYCLING FACILITIES

The three existing roadways that the TIA will consider are Braeside Avenue, Alta Vista Drive, Randall Avenue.

None of these roads are designated as truck routes as identified on the Ottawa Urban Truck Routes map (March 2021) under the jurisdiction of the City of Ottawa. The road classification for City of Ottawa roadways are defined in the City of Ottawa Official Plan, 2013, Volume 1, Section 7, Annex 1 Road Classifications and Rights-of-Way.

Braeside Avenue is an urban local road that runs in a north-south alignment with a posted speed limit of 50 km/h. It has one traffic lane in each direction. The right-of-way adjacent to the proposed development is approximately 20 metres. Street parking is permitted on both sides of the road.

Alta Vista Drive is an urban major collector road that runs in a north-south alignment with a posted speed limit of 50 km/h. It has one traffic lane in each direction. The right-of-way adjacent to the driveway of the proposed development is approximately 30 metres. Street parking is prohibited on both sides of the road.

Randall Avenue is an urban local road that runs in an east-south alignment with a posted speed limit of 50 km/h. It has one traffic lane in each direction. The right-of-way adjacent to the driveway access to the proposed development is approximately 19 metres. Street parking is permitted on both sides of the road.

The existing pedestrian and cycling facilities providing direct connections to the proposed development are shown in **Figure 2-2**. Alta Vista Drive has an on-street cycling lane and 1.5m sidewalk on both sides of the road, while Randall Avenue possesses a 1.5m sidewalk on the north side of the road.

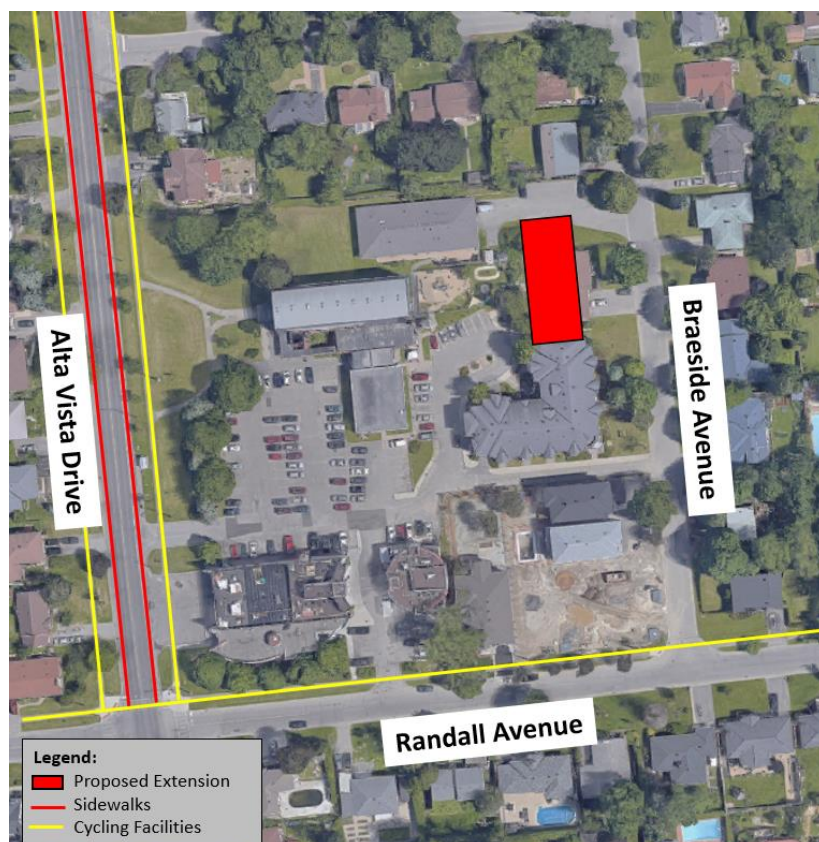

Figure 2-2: Bicycle and Pedestrian Facilities

2.3.2 INTERSECTIONS

The TIA will not consider any intersections in the study area given that the trip generation trigger was not met.

2.3.3 DRIVEWAYS

There are three existing accesses to Ellwood House.

- One access from Braeside Avenue just south of the existing Ellwood House.
- One access from Alta Vista Drive via the parking lot at St. Thomas The Apostle Church parking lot.
- One access from Randall Avenue via the parking lot for Ottawa Fire Station 35. However, it is not expected that any trips to and from 2262 Braeside Avenue will pass through this access.

Additionally, there is one access point to the former rectory at 2262 Braeside Avenue but does not provide access to the parking lot at Ellwood House.

2.3.4 TRANSIT FACILITIES

OC Transpo does not provide transit service along Braeside Avenue. The nearest transit stops are on Alta Vista Drive servicing Route #44 which goes from Hurdman O-Train to Billings Bridge Station. Route 44 is a Frequent Route that operates seven days a week with a 15-minute frequency throughout most of the day.

There are two bus stops within 300 metres of the proposed development that all service Route #44 and are on Alta Vista Drive:

- Bus Stop #7180 is within 150 m from the proposed site
- Bus Stop #7179 is within 250 m from the proposed site

Figure 2-3 highlights all OC Transpo bus stops on adjacent roadways in close proximity of the proposed development.



Figure 2-3: OC Transpo Bus Routes

2.3.5 AREA TRAFFIC MANAGEMENT MEASURES

The existing area traffic management measures identified adjacent to the proposed development site include:

- Boulevards between the sidewalk and road along Alta Vista Drive and Randall Avenue
- Sidewalks are on both sides of Alta Vista Drive
- Alta Vista Drive has curbside bike lanes on both sides of the road with painted lines to delineate from vehicular traffic

2.3.6 PEAK HOUR TRAVEL DEMANDS

The TRANS Committee was established to co-ordinate transportation planning efforts among various planning agencies located within the National Capital Region. For this analysis, the existing mode share of the Alta Vista district for low-rise multifamily housing was taken as the existing mode share. A map of the district area is provided in **Appendix D**. The TRANS mode share for the Alta Vista Area is summarized in **Table 2-1**.

Table 2-1. Existing Mode Share – Alta Vista District (Low-Rise Multifamily Housing)

TRAVEL MODE	AM PEAK PERIOD (7:00 A.M. – 9:30 A.M.)	PM PEAK PERIOD (3:30 P.M. – 6:00 P.M.)
Auto-Driver	38%	38%
Auto-Passenger	15%	19%
Transit	35%	31%
Bicycle	1%	2%
Walk	10%	10%

Source: 2021 TRANS Trip Generation Manual

Reviewing the mode share for the new development, over half are expected to use their personal vehicles to commute as either a driver or passenger. During both AM and PM peak hour periods, auto-driver and auto-passenger modes account for 53% and 57% of the total vehicles that are travelling to and from Ellwood House. Additionally, transit mode share is expected to be over 30% for both peak periods.

2.3.7 FIVE-YEAR COLLISION HISTORY

Using the collision history from the City of Ottawa Open Data, WSP reviewed the number and types of collisions (January 1, 2015 through December 31, 2019) at the three existing access points to Ellwood House. More recent and detailed five-year collision data will be requested from the City in support of a more thorough collision review.

Table 2-2 summarizes the five-year collision history on the boundary road.

Table 2-2. Five Year Collision History Summary

LOCATION	SUMMARY	TRENDS
Access Road: Alta Vista Drive and Access Point	Three collisions over the five-year period.	-
Access Road: Randall Avenue and Access Point	One collision over the five-year period.	-

2.4 PLANNED CONDITIONS

2.4.1 CHANGES TO THE STUDY AREA TRANSPORTATION NETWORK

Based on the City of Ottawa's Construction and Infrastructure projects, the only major project near the adjacent roads expected to this year is a buildings and facilities renewal at Ottawa Fire Station 35. Additionally, there are no proposed transit or active transportation improvements planned near the adjacent roads as part of the Transportation Master Plan (2013)

2.4.2 OTHER STUDY AREA DEVELOPMENTS

As indicated in the City of Ottawa's Development Application Search tool, there are no other developments near the study area that could influence it.

2.5 STUDY AREA

The limits for the Transportation Impact Assessment (TIA) study area are shown in **Figure 2-4**.



Figure 2-4: Study Area

2.6 TIME PERIOD

The time period identified for the traffic analysis are:

- Weekday Peak Hour: 3:15 p.m. to 4:15 p.m.

These are consistent with the peak hour identified in the turning movement counts that were collected at the Alta Vista Drive/Randall Avenue intersection on November 20, 2018.

2.7 HORIZON YEARS

The proposed facility is expected to be completed in one phase with a target build-out year of 2022 and full occupancy in mid 2023. In accordance with the TIA Guidelines, the following horizons will be considered for analysis

- 2023, which represents the anticipated buildout horizon,
- 2028, which represents the buildout year plus five years.

Recall that the trip generation trigger was not satisfied and thus no analysis of the adjacent intersection is proposed.

2.8 EXEMPTIONS REVIEW

Based on the review of the development and network conditions, the following elements shown in **Table 2-3** qualify for an exemption from this Transportation Impact Assessment.

Table 2-3. Exemptions Summary

MODULE	ELEMENT	EXEMPTIONS
DESIGN REVIEW COMPONENT		
4.1 Development Design	4.1.2 Circulation and Access	Not Exempted This element is only required for site plans.
	4.1.3 New Street Networks	Exempted This element is only required for plans of subdivision.
4.2 Parking	4.2.1 Parking Supply	Not Exempted This element is required for site plans.
	4.2.2 Spillover Parking	Exempted This element is only required for site plans where parking supply is 15% below unconstrained demand.
NETWORK IMPACT COMPONENT		
4.5 Transportation Demand Management	All Elements	Not Exempted This element was required for the residential component.
4.6 Neighborhood Traffic Management	4.6.1	Exempted Only required when the development relies on local or collector streets for access and total volumes exceed ATM capacity thresholds.
4.7 Transit		Exempted Required for site plans expected to have more than 60 employees on location at any given time.
4.8 Network Concept		Exempted Required when proposed development generates more than 200 person-trips during the peak hour in excess of the equivalent volume permitted by establishing zoning.

3 FORECASTING

3.1 DEVELOPMENT-GENERATED TRAVEL DEMAND

3.1.1 TRIP GENERATION

Select Base Trip Generation. The 2020 TRANS Trip Generation Manual was used to determine the base trip generation rate for a *Multi-Unit Low-Rise*:

- AM Base Rate: 1.35 person trips per unit (peak period)
- PM Base Rate: 1.58 person trips per unit (peak period)

Estimated Total Development-Generated Person-Trips. In accordance with the City of Ottawa’s Transportation Impact Assessment Guidelines (2017), peak period conversion factors, from the TRANS Trip Generation Manual, were applied to both rates to establish the trip rates for the peak hour.

Ellwood House and the proposed extension is intended to be a safe and affordable permanent home to independent seniors. The TRANS Trip Generation Manual specifically mentions age as an influencing factor on the number of trips generated during a peak hour and a 20% reduction factor was applied to the estimated person trips during each peak hour. The total development-generated person-trips are shown in **Table 3-1**.

Table 3-1. Estimated Total Development-Generated Person-Trips (Multi-Unit Low-Rise)

PEAK HOUR	UNITS	PEAK PERIOD PERSON TRIP RATE	PEAK PERIOD CONVERSION FACTOR	PEAK HOUR PERSON TRIP RATE	TOTAL PERSON TRIPS	REDUCED PERSON TRIPS
AM	38	1.35	0.50	0.68	26	21
PM		1.58	0.44	0.70	27	22

With the residential directional splits from the TRANS Trip Generation Manual, the directional distribution of vehicles entering and exiting was determined and is shown in the following table.

Table 3-2. Directional Splits (Multi-Unit Low-Rise)

PEAK HOUR	PERSON TRIPS	% ENTER	% EXIT	ENTER	EXIT
AM	21	30%	70%	6	15
PM	22	56%	44%	12	10

Identify Existing Mode Share. The existing peak hour travel demand was identified from the most recent TRANS Origin-Destination Survey and presented in **Section 2.3.6**. The existing mode share is based on those values and is shown in the following table.

Table 3-3. Existing Mode Share

PEAK PERIOD	AUTO DRIVER	AUTO PASSENGER	TRANSIT	BICYCLE	WALK
AM	38%	15%	35%	1%	10%
PM	38%	19%	31%	2%	10%

Future Mode Share Targets. The future mode share targets are provided in **Table 3-4.**

Table 3-4. Future Travel Mode Share Targets

TRAVEL MODE	COMMUTER TARGET MODE SHARE	RATIONALE
Auto Driver	38%	Future mode share targets are anticipated to be close to existing conditions based on the nature of the development
Auto Passenger	17%	
Transit	33%	
Bicycle	2%	
Walk	10%	

Projected Development Trips by Mode. Based on the future mode share targets. The number of persons trips to and from the proposed development at 2262 Braeside Avenue are shown in **Table 3-5.**

Table 3-5. Trips Generated by Mode

MODE	TRIPS GENERATED	
	AM Peak Hour	PM Peak Hour
Auto Driver	8	8
Auto Passenger	3	4
Transit	7	7
Bicycle	0	0
Walk	2	2

Trip Reduction Factors. As mentioned earlier, a 20% reduction factor was applied to account for the average age of residents at Ellwood House. No other trip reduction factors were considered for this development based on the existing operations at the Ellwood House.

3.1.2 TRIP DISTRIBUTION

Currently, there are three accesses to Ellwood House, but as mentioned in **Section 2.3.3**, it is not expected that any trips to and from 2262 Braeside Avenue will pass through the access on Randall Avenue that crosses through the parking lot for Ottawa Fire Station 35. The Site Plan (**Appendix C**) indicates two accesses along Alta Vista Drive and two on Braeside Avenue. The trip distribution by cardinal direction for the proposed development is presented as follows:

Table 3-6. Trip Distribution

DIRECTION	CARDINAL DIRECTION SPLIT (%)	
	AM Peak Hour	PM Peak Hour
North	50%	50%
South	50%	50%

3.1.3 TRIP ASSIGNMENT

Trips were assigned to the adjacent transportation network and have been based upon a good understanding of existing travel patterns and the location of the parking spaces assigned to residents of Ellwood House. Since the Braeside Avenue access points are the closest to the parking spaces, it is anticipated that most vehicle trips to and from Ellwood House will pass through the two Braeside access points. The vehicle trips for both AM and PM peak hour were assigned as follows:

- Alta Vista Drive (Northernmost Access Point): 12.5%
- Alta Vista Drive (Southernmost Access Point): 12.5%
- Braeside Avenue (Ingress at North access and Egress at South access): 75%

The overall development-generated demand at the access points is shown in **Figure 3-1**.

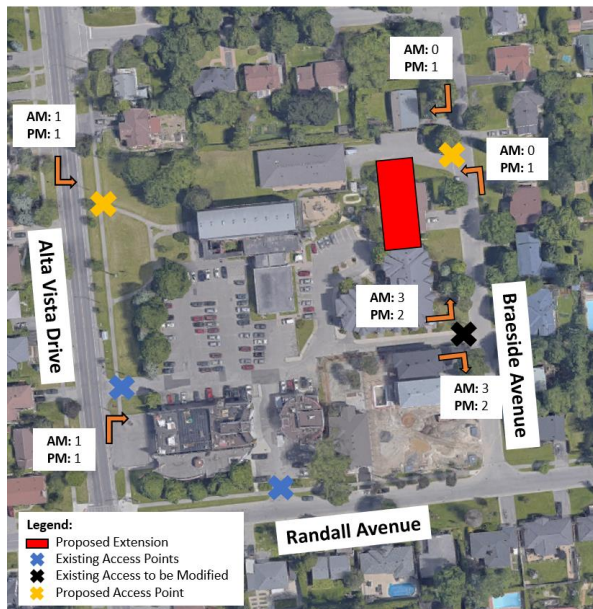

Figure 3-1. Vehicle Trips Generated by Development

3.2 BACKGROUND NETWORK TRAFFIC

Since the Trip Generation Trigger was not satisfied and the Network Analysis component of this TIA study is exempted, background network traffic considerations have not been reviewed.

3.3 DEMAND RATIONALIZATION

Since the Trip Generation Trigger was not satisfied and the Network Analysis component of this TIA study is exempted, the future capacity issues at nearby intersections is studied is not considered in detail. However, a cursory review of the impact of this development to traffic operations on Alta Vista Drive was completed.

As part of the 2008 Transportation Master Plan, the City of Ottawa conducted a Road Infrastructure Needs Study. Within that analysis the assumed capacity at the Smyth/Hydro Screenline and Alta Vista Drive is 600 veh/hour per lane per direction. Given the proximity to the Alta Vista/Randall intersection and the similar cross-section on Alta Vista Drive, it can be assumed that the capacity is similar.

A traffic count from November 2018 indicated the following through volumes on Alta Vista Drive, north of the Alta Vista/ Randall intersection:

- AM Peak Hour (Northbound): 506
- AM Peak Hour (Southbound): 416
- PM Peak Hour (Northbound): 454
- PM Peak Hour (Southbound): 602

From the 2018 traffic counts, the southbound PM peak hour volumes are already exceeding the assumed lane capacity of 600 veh/h. However, as shown in **Section 3.1.3**, most vehicle trips generated are expected to enter and exit via the Braeside Avenue accesses with only one or two vehicles expected to use the Alta Vista Drive accesses.

4 STRATEGY

4.1 DEVELOPMENT DESIGN

4.1.1 DESIGN FOR SUSTAINABLE MODES

The TDM-supportive Development Design and Infrastructure Checklist includes two checklists, one for non-residential developments, and one for residential developments. The residential development checklist was completed to assess the opportunity to implement facilities that are supportive of sustainable modes. The completed checklist is attached as **Appendix E**.

Sustainable modes include cycling, walking and transit. As indicated in the checklist and shown on the proposed site plan, the proposed development accommodates cycling by providing the necessary bicycle parking and walking by providing safe and direct pedestrian access from Braeside Avenue and the internal parking lot.

There are sidewalks within the internal parking lot that will allow pedestrians attempting to access transit facilities the ability to access the sidewalks along Alta Vista Drive or Randall Avenue. Most notably, the sidewalk along the north side of the St. Thomas Church connects to the accessible concrete walkway leading to Alta Vista Drive and nearby transit that was previously identified in Section 2.3.4. Pedestrians would still require to briefly cross through the parking lot, but most of their trip to the Alta Vista Drive sidewalk would be separated from vehicles.

Similarly, the access to the Randall Avenue sidewalk requires pedestrians to cross the parking lot for a short distance where a sidewalk is not provided. Therefore, while the pedestrian access is short and direct to the transit stations, additional support could be provided within the internal parking lot or a sidewalk could be provided along Braeside Avenue to connect to the Randall Avenue sidewalk.

4.1.2 CIRCULATION AND ACCESS

The proposed site plan (**Appendix C**) provides a continuous drive movement between the three access points within the shared parking lot for maintenance vehicles that require reverse maneuvering. The site circulation was assessed using AutoTURN 11.0 to confirm suitability of the layout for a variety of design vehicles. The results are provided in the following table and the AutoTURN swept paths are provided in **Appendix F**.

The swept path assessment indicates that the heavy single unit design vehicles will have difficulty turning into the new proposed access on Alta Vista Drive. It is recommended that this entrance be signed as a No Truck entrance with larger vehicles circulating through the site using the existing south entrance on Alta Vista Drive.

Table 4-1. Swept Path Assessment

DESIGN VEHICLE	VEHICLE REPRESENTING	FINDINGS
HSU (TAC 2017)	Municipal Services/ Waste Removal	Circulation: HSU vehicles are able to enter and exit through the existing Alta Vista Drive access. Access to Loading Dock: HSU vehicle can approach area but is not capable of fully backing into the location where the location of the potential future garbage room extension. This is unchanged from existing conditions.

4.1.3 NEW STREET NETWORKS

This section was exempted in the Transportation Impact Assessment Scoping Report submitted on October 13, 2021 and approved by the City of Ottawa on October 13, 2021. The approved exemption table is found in **Section 2.8**.

4.2 PARKING

4.2.1 PARKING SUPPLY

The proposed development parking requirements, based on its location, will be assessed in accordance with the Outer Urban/Inner Suburban Area (Area 'B') for minimum parking requirements as part of Schedule 1A to the City of Ottawa's Zoning By-Law 2008-250.

The minimum parking supply requirements for this development compared with the proposed parking supply are highlighted in **Table 4-2** and **Table 4-3**. Note that since the parking lot for all users of St. Thomas Church & School, Braeside House, and Ellwood House is shared, the parking spaces have been redistributed to meet the By-Law requirements.

Table 4-2. Minimum By-Law Requirements for Vehicular Parking and Proposed Parking Supply

TYPE	REQUIRED	CALCULATION	SITE PLAN	COMPLIANCE WITH BY-LAW
Vehicle – St. Thomas Church	103	10 spaces * 100m ² of gross floor area of assembly areas (1,027 m ²)	103	Meets the minimum requirements of the Zoning By-Law
Vehicle – St. Thomas Nursery	6	2 spaces * 100m ² of gross floor area (284.7 m ²)	6	Meets the minimum requirements of the Zoning By-Law
Vehicle – Braeside House	3	1 space * 100m ² of gross floor area (342.6 m ²)	4	Exceeds the minimum requirements of the Zoning By-Law
Vehicle – Ellwood House	8	0.25 spaces per dwelling units (30 dwelling units)	18	Meets the minimum requirements of the Zoning By-Law
Vehicle – Ellwood House Extension	10	0.25 spaces per dwelling units (38 dwelling units)		
Total	130		131	

Table 4-3. Minimum By-Law Requirements for Bicycle Parking and Proposed Parking Supply

TYPE	REQUIRED	CALCULATION	SITE PLAN	COMPLIANCE WITH BY-LAW
Bicycle – St. Thomas Nursery	1	1 spaces * 250m ² of gross floor area (284.7 m ²)	21	Meets the minimum requirements of the Zoning By-Law
Bicycle – Braeside House	2	0.25 space per dwelling unit (8 dwelling units)		
Bicycle – Ellwood House	8	0.25 spaces per dwelling units (30 dwelling units)		
Bicycle – Ellwood House Extension	10	0.25 spaces per dwelling units (38 dwelling units)		
Total	21		21	

4.2.2 SPILLOVER PARKING

This section was exempted in the Transportation Impact Assessment Scoping Report submitted on October 13, 2021 and approved by the City of Ottawa on October 13, 2021. The approved exemption table is found in **Section 2.8**.

4.3 BOUNDARY STREETS

4.3.1 ALTA VISTA DRIVE

Alta Vista Drive is a major collector road with an existing 30-metre protected right-of-way in the study area adjacent to the proposed development site. The existing cross-section (**Figure 4-1**) includes a paved area approximately 11m wide with sidewalks in each direction with no median. The right-of-way allocation exceeds the minimum width requirement of 22m for a neighborhood collector street as per the City of Ottawa’s Designing Neighborhood Collector Streets (2019) document.



Figure 4-1. Alta Vista Drive - Existing Cross-Section

4.3.1.1 MOBILITY

The segment of Alta Vista Drive within the study area is identified as a General Urban Area in the City of Ottawa’s Official Plan (2013), Schedule B (Urban Policy Plan). The development is not proposing any changes to the boundary street. The resulting MMLOS targets and scores are indicated in **Table 4-4**. The MMLOS targets are based on a policy area within 300m of a school due to its proximity to Alta Vista Public School. The MMLOS calculation sheet can be found in **Appendix G**.

Table 4-4. Segment MMLOS - Alta Vista Drive

	PLOS	BLOS	TLOS	TKLOS	VLOS
Target	A	B	D	-	VLOS Not Reported for Segments
Status Quo	C	B	D	-	

The PLOS ‘A’ is not achieved, in part, because the segment has an AADT greater than 3,000 and the operating speed along Alta Vista Drive is 50 km/h. A PLOS ‘A’ could only be attained if operating speed is reduced to 30 km/h.

4.3.1.2 SAFETY

Historical crash records for the study area were obtained from the City of Ottawa for the five years between January 2015 and December 2019. The TIA Guidelines indicate that patterns with six or more crashes should be identified. In this timeframe, there were three collisions along the roadway segment on Alta Vista Drive, and thus do not meet the TIA Guideline criteria.

4.3.2 BRAESIDE AVENUE

Braeside Avenue is a local road with an existing 20-metre protected right-of-way in the study area adjacent to the proposed development site. The existing cross-section (**Figure 4-2**) includes a paved area approximately 8m with no sidewalks or bicycle lanes. The right-of-way allocation does not meet the minimum width requirement of 22m for a neighborhood collector street as per the City of Ottawa’s Designing Neighborhood Collector Streets (2019) document.



Figure 4-2. Braeside Avenue - Existing Cross-Section

4.3.2.1 MOBILITY

The segment of Braeside Avenue within the study area is identified as a General Urban Area in the City of Ottawa’s Official Plan (2013), Schedule B (Urban Policy Plan). The development is not proposing any changes to the boundary street. The resulting MMLOS targets and scores are indicated in **Table 4-5**.

Table 4-5. Segment MMLOS - Braeside Avenue

	PLOS	BLOS	TLOS	TKLOS	VLOS
Target	A	D	-	-	VLOS Not Reported for Segments
Status Quo	F	B	-	-	

The PLOS ‘A’ is not achieved, in part, because there is no sidewalk and the operating speed along Braeside Avenue is 50 km/h. A PLOS ‘A’ could be attained with the implementation of a 1.8m sidewalk and a 2m boulevard.

4.3.2.2 SAFETY

Historical crash records for the study area were obtained from the City of Ottawa for the five years between January 2015 and December 2019. The TIA Guidelines indicate that patterns with six or more crashes should be identified. In this timeframe, there were no collisions along the roadway segment on Braeside Avenue, and thus do not meet the TIA Guideline criteria.

4.4 ACCESS INTERSECTION

4.4.1 LOCATION AND DESIGN OF ACCESS

There are three new access points proposed for this development and are indicated in the Site Plan (**Appendix C**), one on Alta Vista Drive and two on Braeside Avenue. The Alta Vista Drive entrance is proposed as full movement, whereas the Braeside Avenue entrances are ingress only (north) and egress only (south).

A design compliance check was carried out for each of the two accesses following guidelines prepared by the City of Ottawa and the Transportation Association of Canada's Geometric Design Guidelines for Canadian Roads (2017). The design compliance check is summarized in **Table 4-6**.

Table 4-6. Access Intersection Design Elements

DESIGN ELEMENTS	MINIMUM REQUIRED	ALTA VISTA DRIVE (NEW)	BRAESIDE AVENUE (SOUTH)	BREAESIDE AVENUE (NORTH)
Access Type	-	Full Movement	Egress Only	Ingress Only
One-way vs. Two-way	<25 vpd = one-way driveway <750 vpd = two-way driveway	<40 peak hour trips ~400 daily trips Two-Way	<10peak hour trips ~100 daily trips One-Way	<10peak hour trips ~100 daily trips One-Way
Entrance Width	Two- Way: 2.0m -7.3m (TAC 2017) One-Way: 3.0m-4.3m (TAC 2017)	6.9 m	3.7m	4.0 m
Corner Clearance	70m to traffic signals (TAC 2017)	>70m	>70m	>70m
Right Turn Radius	3.0 – 4.5m (TAC 2017)	1.5m	2.7m	3.0m
Sight Distance (Intersection with No Control)	Left turn: 130m (TAC 2017)	No obstruction	No obstruction	No obstruction
	Right turn: 110m (TAC 2017)	No obstruction	No obstruction	No obstruction
Throat Length	15m for Alta Vista 8m for Braeside (TAC 2017)	19m	40m	30m
Angle of Intersection	At or near 90°	Access to parking lot at intersection is 90°	Access to parking lot at intersection is 90°	Access to parking lot at intersection is 90°

DESIGN ELEMENTS	MINIMUM REQUIRED	ALTA VISTA DRIVE (NEW)	BRAESIDE AVENUE (SOUTH)	BREAESIDE AVENUE (NORTH)
Proximity to Adjacent Driveways	1m between driveways (TAC 2017)	Private driveway 15 m north of access	Private driveway 5 m south of access	Private driveway 5 m north of access
Pedestrian Crossing Consideration	Ottawa Standard Drawing SC7.1 (Curb Return Private Entrance - Unsignalized)	6.9m pedestrian crossing Ottawa Standard SC7.1 (Curb Return at a Private Entrance)	3.7m pedestrian crossing (No sidewalk on Braeside)	4.0m pedestrian crossing (No sidewalk on Braeside)
Cycling Crossing Consideration	Large curb return radii with narrow driveway to minimize crossing distance	10.5m cycling crossing	6.1m cycling crossing	7.3m cycling crossing

Generally, the proposed accesses meet the current best practices and accepted design guidance apart from the right turn radius at both accesses. Right turn radii for Alta Vista Drive and Braeside Avenue (south) do not meet the minimum TAC requirement of 3.0m and is, in part, why the turning movements from **Section 4.1.2** were not ideal.

4.4.2 INTERSECTION CONTROL

An all-way stop minimum volume warrant for the minor road was conducted in accordance with the Ontario Traffic Manual (OTM) Book 5 for both proposed accesses under the future total planning horizon. Both of the following conditions must be met to warrant a stop at the two access points as illustrated in **Table 4-7**.

Table 4-7. All-Way Stop (Minor Road) Requirements

CONDITION	FUTURE TOTAL PLANNING HORIZON	
	Alta Vista Drive	Braeside Avenue
Total vehicle volume on all intersection approaches exceeds 350 for the highest hour recorded	Estimated Volumes: AM >500 PM: >1000	Estimated Volumes: AM <200 PM: <200
Volume split does not exceed 75/25 for three-way control or 65/35 for four-way control. Volume is defined as vehicles only	Volume Splits: AM: 95/5 PM: 95/5	Volume Splits: AM: 90/10 PM: 90/10

While the total vehicle volume is expected to exceed 350 for the highest hour recorded on Alta Vista Drive, the volume split is anticipated to greatly exceed 75/25 for a three-way control intersection. Similarly, the Braeside Avenue access

is not expected to meet the necessary volume or volume split. Therefore, a stop control on the minor road was not warranted, and accordingly a traffic signal warrant was not analyzed.

For the Alta Vista entrance, pedestrian accommodations at the accesses should follow the City of Ottawa’s Standard Drawing SC7.1 for Curb Return Entrances utilizing the Private / Unsignalized entrance option which includes a continuous depressed sidewalk across the access as shown below.

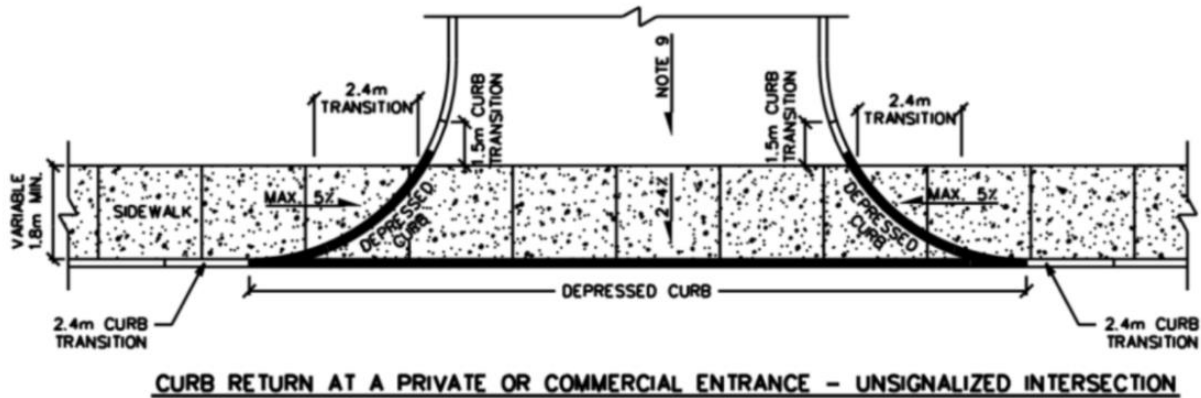

Figure 4-3. City of Ottawa, Standard Drawing SC 7.1 Curb Return Entrances, Private/Unsignalized (March 2017)

Signage options for the three driveways are provided below:

Braeside Avenue (both accesses): Wayfinding signage indicating that this is the entrance nearest the delivery truck entrance.

Alta Vista Drive: Signage indicating that no trucks shall enter from both the north and south entrances.

4.4.3 INTERSECTION DESIGN

The City of Ottawa’s Multi-modal Level of Service (MMLOS) Guildelines (2015) note that the intersection MMLOS evaluation does not apply to unsignalized intersections, The four driveway accesses are proposed to be or remain unsignalized and no further evaluation was completed.

4.5 TRANSPORTATION DEMAND MANAGEMENT

4.5.1 CONTEXT FOR TDM

Transportation Demand Management (TDM) describes a broad range of policies, programs and services designed to reduce the demand for vehicle use by influencing individual travel behaviour and providing expanded options. As mentioned in **Section 3.1.1**, the forecasted commuter mode share is: 38% auto driver, 33% transit, 17% auto passenger, 10% walking and 2% bicycle.

4.5.2 NEED AND OPPORTUNITY

With less than 10 vehicle trips expected from the proposed development during peak hours, limited impact should be anticipated to the existing road network.

4.5.3 TDM PROGRAM

The TDM-supportive Development Design and Infrastructure Checklist was completed to assess the opportunity to implement facilities that are supportive of sustainable modes. The completed checklist is attached to this report as **Appendix H**.

The sustainable mode share at the proposed development can be maximized by including the following DM measures and amenities:

- Provide shuttle service for mall and/or supermarket runs
 - Display relevant transit schedules at entrances
 - Provide one monthly preloaded PRESTO card for new residents
 - Display local area maps with walking/cycling access routes
-

4.6 NEIGHBOURHOOD TRAFFIC MANAGEMENT

This section was exempted in the Transportation Impact Assessment Scoping Report submitted on October 13, 2021 and approved by the City of Ottawa on October 13, 2021. The approved exemption table is found in **Section 2.8**.

4.7 TRANSIT

This section was exempted in the Transportation Impact Assessment Scoping Report submitted on October 13, 2021 and approved by the City of Ottawa on October 13, 2021. The approved exemption table is found in **Section 2.8**.

4.8 REVIEW OF NETWORK CONCEPT

This section was exempted in the Transportation Impact Assessment Scoping Report submitted on October 13, 2021 and approved by the City of Ottawa on October 13, 2021. The approved exemption table is found in **Section 2.8**.

4.9 INTERSECTION DESIGN

This section was exempted in the Transportation Impact Assessment Scoping Report submitted on October 13, 2021 and approved by the City of Ottawa on October 13, 2021. The approved exemption table is found in **Section 2.8**.

4.10 SUMMARY OF IMPROVEMENTS INDICATED AND MODIFICATION OPTIONS

A summary of transportation improvements proposed as part of this Transportation Impact Assessment are presented as follows:

Development Design

- a) Provisions for sustainable modes on-site have been identified through the development design checklist. The proposed site plan accommodates cycling by providing the necessary bicycle parking and walking by providing safe and direct pedestrian access from Braeside Avenue and the internal parking lot.
- b) Heavy vehicle (HSU) circulation on-site is proposed between the realigned Braeside Avenue driveway and the existing Alta Vista Drive access. It is proposed that the new north access on Alta Vista Drive be signed as No Truck Entry.

Reference: Section 4.1

Parking

- a) The proposed bicycle and vehicle parking satisfy the requirements of the Zoning By-Law (2008-250).

Reference: Section 4.2

Boundary Street Design

- a) There are no proposed changes to the cross-sections of Alta Vista Drive and Braeside Avenue adjacent to the proposed development.
- b) The status quo MMLOS assessment of Alta Vista Drive and Braeside Avenue resulted in the BLOS meeting the MMLOS targets for the General Urban policy area, while the PLOS did not achieve the target because of the narrow width of the existing sidewalks.

Reference: Section 4.3

Access Intersections

- a) **New Alta Vista Drive Access:** The access is proposed as full movement with unimpeded traffic flow along Alta Vista Drive. It provides access to Ellwood House via the connected parking lot with St. Thomas Church. Generally, the access design meets the minimum requirements provided by the TAC Geometric Design Guide for Canadian Roads, however the right turn radius may not easily accommodate the larger fleet vehicles and restricting truck access is recommended.
- b) **Realigned Braeside Avenue Accesses:** These accesses as ingress only (north access) or egress only (south access) with unimpeded traffic flow along Braeside Avenue and provides direct access to Ellwood House. Generally, the access design meets the minimum requirements provided by the TAC Geometric Design Guide for Canadian Roads, however the turning radius may not easily accommodate the larger fleet vehicles.

Reference: Section 4.4

Transportation Demand Management

- a) The existing road network has available capacity should the anticipated mode share targets not be met.

Reference: Section 4.5

APPENDIX

A CIRCULATION COMMENT / RESPONSE



COMMENT AND RESPONSE LOG

TO: File
FROM: Kimberley Hunton, P. Eng.
SUBJECT: 2262 Braeside Avenue Transportation Impact Assessment (current to May 2, 2022)
DATE: May 2, 2022

SCOPING REPORT COMMENT / RESPONSE

WSP Submission October 14, 2021
City Comments Received October 14, 2021

Section 2.8 Exemptions Review

- 1** Element 4.1.2. Clarify the rear lane delivery access needs to indicate how it is intended to function. Truck turning templates for municipal services as well as deliveries will also be required.
Will be included in Strategy Report.
- 2** Element 4.2.1. Provide a table indicating the required parking to meet the zoning by-law and the proposed number of parking spaces.
Will be included in Strategy Report.
- 3** Although the number of forecasted person trips may be less than 60, include Module 4.5 for the residential component. For example, ensuring that bicycle parking is appropriately placed and easily accessed will support this mode share. Include Module 4.5 - TDM Measures. For additional assistance with TDM strategies, contact Kathleen.Wilker@ottawa.ca
Will be included in Strategy Report.

Next Steps

- 4** **Please proceed to the forecasting report.**
Thank you. Forecasting and Strategy Report completed and submitted for comment on October 25 2021.
-

FORECASTING AND STRATEGY REPORT COMMENT / RESPONSE

WSP Submission October 25, 2021
City Comments Received February 2, 2022

Section 4.1 Development Design

- 1 In Section 4.1.1 of the report, please elaborate on the available transit facilities and the distances from the development to these facilities. Ensure that the site plan and report reflect the correct amount of ZBL parking spaces required.

Information on the available transit facilities is presented in Section 2.3.4 of the TIA Final Report. The site plan and Section 4.2.1 provide information on the ZBL parking spaces required. Additional clarification was provided in the Section 4.1.1.
- 2 Please describe the anticipated path of travel for pedestrians between the development and transit service on Alta Vista, and how this has been considered as part of a design for sustainable modes. Please describe if there are any opportunities to improve/ provide dedicated pedestrian facilities between the proposed building extension and transit stops on Alta Vista through the site (2262-2270 Braeside/ 2345 Alta Vista).

Pedestrians must choose to either walk within the internal parking lot, which does provide some sidewalk or on the street on Braeside Avenue to access either the Alta Vista Drive or Randall Avenue sidewalks. Additional text was added to the TIA Final Report in Section 4.1.1 and Appendix E (Development Design and Infrastructure Checklist).
- 3 Confirm that the proposed site plan does not conflict with the approved Alta Vista Functional Design Study

The proposed site plan does conflict with the Alta Vista Functional Design Study. More specifically, the proposed driveway on Alta Vista Drive conflicts with the location of the relocated NB bus shelter. The location of the entrance has been developed in its current location so as to preserve and maximize public space (i.e. community gardens) and provide more direct access to accessible parking. Given the construction of the proposed development is expected before the Alta Vista Corridor Road Detailed Design, it is recommended that the final bus shelter location be identified during the Alta Vista Corridor Detailed Design in consultation with OC Transpo (e.g. south of the proposed driveway).

Section 4.3 Boundary Streets

- 4 Due to the nearby Alta Vista Public School, Tables 4-4 and 4-5 should reflect the associated enhanced MMLOS targets (please refer to Exhibit 22 of the MMLOS Guidelines). Also, please provide the MMLOS calculations. For instance, Alta Vista Drive may have a PLOS value that is worse than 'D'.

Updated tables and appendix will be provided in TIA Final Report.

Section 4.4 Access Intersections

- 5 The realigned Braeside Avenue access is less than 3m away from the adjacent property line. This does not conform to section 25.1.p of the PABL and if accepted would require a bylaw exemption.

The bylaw includes an exemption where the offset can be minimized to 0.3 meters provided that the proposed access is located a safe distance from the access serving the adjacent property, adequate sightlines are provided and does not create a traffic hazard. The current plan shows a 2-meter offset. The safety review in Section 4.3.2.2 of the TIA Final Report indicates that there were no collisions on Braeside Avenue from 2015 to 2019 and given the geometric layout of the road (no bends or curves) a bylaw exemption should be feasible and will be pursued as required.
- 6 Please provide slope of accesses. Note that as per section 25.1.u of the Private Approach By-Law, the slopes should not exceed 2% for a distance of 9 metres from the street line.



Additional details will be provided in updated Site Plan.

Section 4.5 Transportation Demand Management

- 7 Please provide additional TDM measures to help reduce dependency on vehicles. For instance, to encourage transit usage, providing a prepaid Presto pass is a proven tool.
- Since the Ellwood House extension provides additional housing for independent seniors (who may be less mobile) and that the future mode share (Table 3-4) for auto driver is expected to only be 38%, there are limited opportunities for additional TDM measures. With that said, a monthly Presto card option for new residents was added to Section 4.5.3 and the TDM Checklist (Appendix H) of the TIA Final Report.

Additional Comments

- 8 Transit Services - Section 2.3.4:
- a Route 44 operates between Hurdman Station and Billings Bridge Station.
Noted and updated in the TIA Final Report.
 - b Route 44 is a 'Frequent' route that operates on a 15-minute frequency during most time periods of the day.
Noted and updated in the TIA Final Report.
 - c Route 44 services stops on Alta Vista, not Route 46.
Noted and updated in the TIA Final Report.
 - d Figure 2-3 highlights bus stops, not routes.
Noted and updated in the TIA Final Report

Prepared by:

Kimberley Hunton, P. Eng.
Project Manager, Transportation Planning

APPENDIX

B

SCREENING
FORM

City of Ottawa 2017 TIA Guidelines Screening Form

1. Description of Proposed Development

Municipal Address	2262 Braeside Avenue - Ellwood House Extension
Description of Location	Located on the west side of Braeside Ave. south of Clontarf Ave.
Land Use Classification	3.5-storey retirement home
Development Size (units)	38 residential units
Development Size (m ²)	2,375 (building gross area - including basement)
Number of Accesses and Locations	One realigned access on Braeside Avenue (NE corner of site)*
Phase of Development	Single Phase
Buildout Year	N/A

If available, please attach a sketch of the development or site plan to this form.

2. Trip Generation Trigger

Considering the Development's Land Use type and Size (as filled out in the previous section), please refer to the Trip Generation Trigger checks below.

Land Use Type	Minimum Development Size
Single-family homes	40 units
Townhomes or apartments	90 units
Office	3,500 m ²
Industrial	5,000 m ²
Fast-food restaurant or coffee shop	100 m ²
Destination retail	1,000 m ²
Gas station or convenience market	75 m ²

** If the development has a land use type other than what is presented in the table above, estimates of person-trip generation may be made based on average trip generation characteristics represented in the current edition of the Institute of Transportation Engineers (ITE) Trip Generation Manual.*

If the proposed development size is greater than the sizes identified above, the Trip Generation Trigger is satisfied.

38 residential units (ITE 252)
 Estimated <20 peak hour vehicle trips



3. Location Triggers

	Yes	No
Does the development propose a new driveway to a boundary street that is designated as part of the City's Transit Priority, Rapid Transit or Spine Bicycle Networks?		X
Is the development in a Design Priority Area (DPA) or Transit-oriented Development (TOD) zone?*		X

*DPA and TOD are identified in the City of Ottawa Official Plan (DPA in Section 2.5.1 and Schedules A and B; TOD in Annex 6). See Chapter 4 for a list of City of Ottawa Planning and Engineering documents that support the completion of TIA).

If any of the above questions were answered with 'Yes,' the Location Trigger is satisfied.

4. Safety Triggers

	Yes	No
Are posted speed limits on a boundary street are 80 km/hr or greater?		X
Are there any horizontal/vertical curvatures on a boundary street limits sight lines at a proposed driveway?		X
Is the proposed driveway within the area of influence of an adjacent traffic signal or roundabout (i.e. within 300 m of intersection in rural conditions, or within 150 m of intersection in urban/ suburban conditions)?		X
Is the proposed driveway within auxiliary lanes of an intersection?		X
Does the proposed driveway make use of an existing median break that serves an existing site?		X
Is there is a documented history of traffic operations or safety concerns on the boundary streets within 500 m of the development?		X
Does the development include a drive-thru facility?		X

If any of the above questions were answered with 'Yes,' the Safety Trigger is satisfied.

5. Summary

	Yes	No
Does the development satisfy the Trip Generation Trigger?		X
Does the development satisfy the Location Trigger?		X
Does the development satisfy the Safety Trigger?		X

If none of the triggers are satisfied, the TIA Study is complete. If one or more of the triggers is satisfied, the TIA Study must continue into the next stage (Screening and Scoping).

* It is our understanding that the potential entrance from Alta Vista Drive to parking lot 5 is to be a separate project to potentially provide contingency parking for existing uses. If considered as part of this site plan application, then the entrance would satisfy the location and safety triggers.

APPENDIX

C DRAFT SITE PLAN



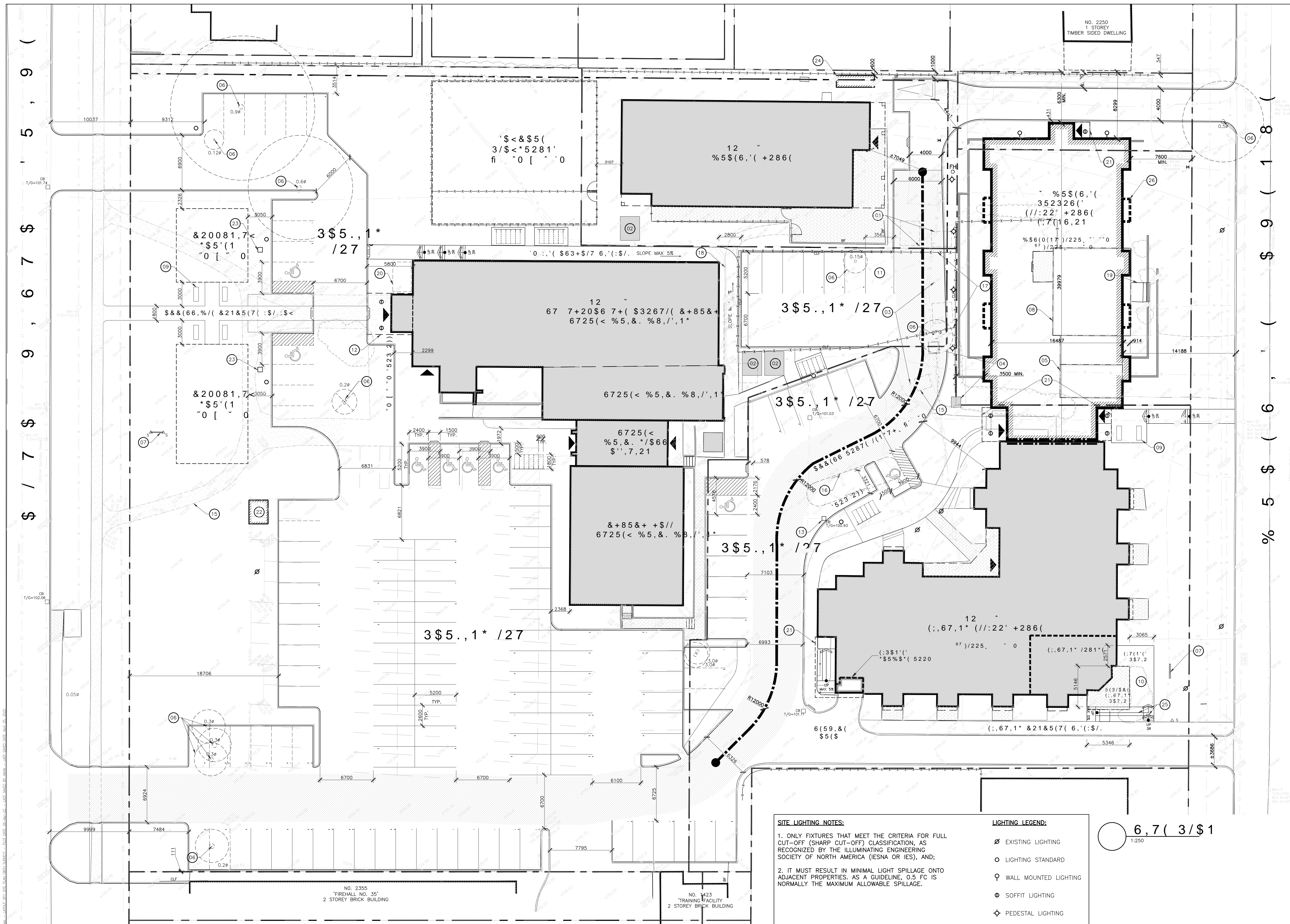

LOCATION MAP

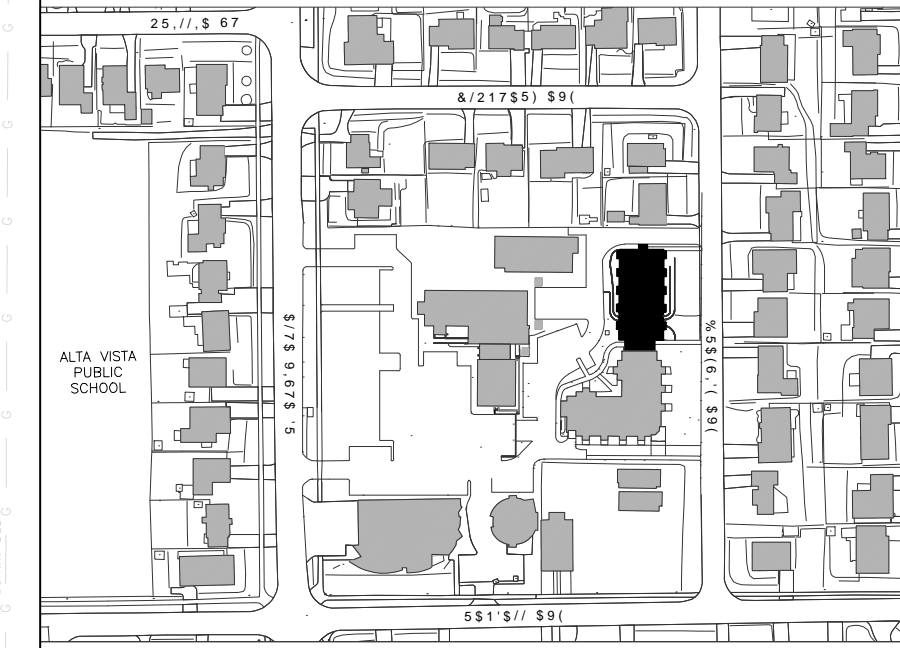

CONTACT LIST:

OWNER
 ELLWOOD HOUSE LTD.
 2270 BRAESIDE AVENUE
 OTTAWA, ON K1H 7J7
 613-521-5151

DEVELOPMENT CONSULTANT
 CENTRETOWN CITIZENS OTTAWA CORPORATION (COCOC)
 415 GILMOUR STREET, SUITE 200
 OTTAWA, ON K2P 2M8
 613-234-4065

PLANNER
 WSP INC.
 2611 QUEENSWAY DRIVE
 OTTAWA, ON K2B 8K2
 613-829-2800

ARCHITECT
 COLIZZA BRUNI ARCHITECTURE INC.
 76 CHAMBERLAIN AVENUE
 OTTAWA, ON K1S 1V9
 613-236-2944

LANDSCAPE ARCHITECT
 STUDIO RED LANDSCAPE ARCHITECTURE INC.
 76 CHAMBERLAIN AVENUE
 OTTAWA, ON K1S 1V9
 613-866-4551

STRUCTURAL ENGINEER
 D+M STRUCTURAL ENGINEERING LTD.
 120-17 ABERDEEN STREET
 OTTAWA, ON K1S 3J5
 613-651-9490

MECHANICAL/ELECTRICAL ENGINEER
 COSMEL CORP.
 175 GREER BOULEVARD, SUITE 105
 GATINEAU, QC JBT 6Z6
 819-205-3283

SURVEYOR
 FARLEY, SMITH & DENIS SURVEYING LTD.
 190 COLONNADE ROAD
 OTTAWA, ON K2E 7J5
 613-727-8226

SURVEY INFORMATION
 PART OF BLOCK N
 REGISTERED PLAN 552
 CITY OF OTTAWA

GENERAL NOTES

IT IS THE RESPONSIBILITY OF THE CONTRACTOR TO VERIFY ALL DIMENSIONS ON SITE AND REPORT ANY ERRORS AND OMISSIONS TO THE ARCHITECT. ALL CONTRACTORS MUST COMPLY WITH ALL PERTINENT CODES AND BY-LAWS. DO NOT SCALE DRAWING. THESE DRAWINGS MAY NOT BE USED FOR CONSTRUCTION UNTIL SIGNED. THIS DRAWING IS THE EXCLUSIVE PROPERTY OF COLIZZA BRUNI ARCHITECTURE INCORPORATED. COPYRIGHT RESERVED.

DEVELOPMENT INFORMATION:

ZONING:
 I1A (1485)

UNITS:
 28x TYPE A
 1 BDRM UNIT
 (NET) 47.26 M² / 508.7 FT²

6x TYPE B
 1 BDRM BARRIER FREE
 (NET) 47.28 M² / 508.9 FT²

4x TYPE C
 1 BDRM
 (NET) 44.6 M² / 479.9 FT²

38 IN TOTAL

BUILDING FOOTPRINT AREA:
 628.9 M² / 6,769 FT²

BUILDING GROSS AREA:
 (INCLUDING BASEMENT)
 2,459 M² / 26,476 FT² (NET)

COMMON AREAS (GFA)
 479 M² / 5,156 FT² (NET)

EFFICIENCY:
 80%

PARKING INFORMATION:

NUMBER OF PARKING SPACES AT 2.6M x 5.2M:
 REQUIRED: 130
 PROVIDED: 131 (8 BARRIER FREE)

LINE DENOTES:
 --- EXISTING PARKING SPACES: 104
 - - - - - PROPOSED PARKING SPACES: 27

NUMBER OF BICYCLE PARKING AT 0.6M x 1.8M:
 REQUIRED: 21
 PROVIDED: 21

OUTDOOR AMENITY AREAS:

REQUIRED MIN. TOTAL AMENITY: 228 M²
PROPOSED AMENITY AREAS:
 COMMUNITY GARDENS: 217.8 M²
 EXISTING PATIO: 20.87 M²
 PROPOSED PATIO: 27.89 M²
IN TOTAL: 266.56 M²

PERCENTAGE OF TOTAL SITE OCCUPIED BY VEGETATION AND LANDSCAPING:
 43%

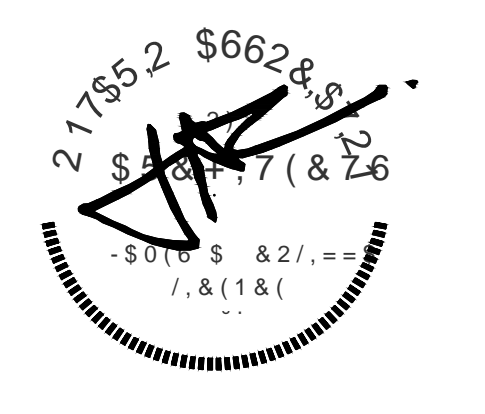

SITE LIGHTING NOTES:

- ONLY FIXTURES THAT MEET THE CRITERIA FOR FULL CUT-OFF (SHARP CUT-OFF) CLASSIFICATION, AS RECOGNIZED BY THE ILLUMINATING ENGINEERING SOCIETY OF NORTH AMERICA (IESNA OR IES), AND;
- IT MUST RESULT IN MINIMAL LIGHT SPILLAGE ONTO ADJACENT PROPERTIES, AS A GUIDELINE, 0.5 FC IS NORMALLY THE MAXIMUM ALLOWABLE SPILLAGE.

LIGHTING LEGEND:

- ⊙ EXISTING LIGHTING
- LIGHTING STANDARD
- ◐ WALL MOUNTED LIGHTING
- ◑ SOFFIT LIGHTING
- ◇ PEDESTAL LIGHTING

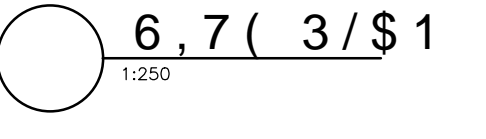

DRAWING LEGEND:

- ▒ EXISTING CONSTRUCTION
- ▒ NEW CONSTRUCTION (SCOPE OF WORK)
- TREES TO BE REMOVED
- TREES TO BE RELOCATED - REFER TO TREE CONSERVATION REPORT
- SHRUBS TO BE REMOVED
- FH EXISTING FIRE HYDRANT
- EXISTING FENCE
- ▒ RETAINING WALL
- ▒ DEPRESSED CURB AND TWSI
- ▒ BIKE RACKS
- ▒ 6M WIDE FIRE ROUTE ACCESS
- ▒ 2HR FIREWALL

DRAWING NOTES:

- ① EXISTING SHEDS TO BE RELOCATED
- ② RELOCATED SHEDS
- ③ RELOCATE LIGHT POLES
- ④ RELOCATE HYDRO TRANSFORMER
- ⑤ EXISTING RECTORY TO BE DEMOLISHED
- ⑥ REMOVE EXISTING TREES
- ⑦ EXISTING SIGNS
- ⑧ EXISTING HOME TO BE DEMOLISHED
- ⑨ 0.6Mx1.8M BENCH
- ⑩ NEW ENLARGED PATIO TO REPLACE EXISTING
- ⑪ VAN PARKING
- ⑫ REMOVE PART OF EXISTING CANOPY
- ⑬ EXISTING CATCH BASIN
- ⑭ EXISTING CONCRETE SIDEWALK TO BE REMOVED
- ⑮ EXISTING WALKWAY TO BE REMOVED
- ⑯ EXISTING PLANTER TO BE REMOVED
- ⑰ EXISTING CHAIN LINK FENCE TO BE REMOVED
- ⑱ EXISTING CONCRETE RETAINING WALL TO BE REMOVED
- ⑲ EXISTING CONCRETE PORCH AND STEPS TO BE REMOVED
- ⑳ LOCATION OF MEMORIAL
- ㉑ LINE OF NEW CANOPY ABOVE
- ㉒ 2.4Mx3.0M GARDEN SHED
- ㉓ WATER OUTLET FOR GARDEN
- ㉔ 1.5Mx4.8M GARBAGE SHED
- ㉕ CONCRETE STAIRS AND RAMP
- ㉖ BAY PROJECTION ABOVE

PARKING LOT LANDSCAPE:

DESIGNATION:

- ▒ PARKING LOT
- ▒ LANDSCAPED AREA

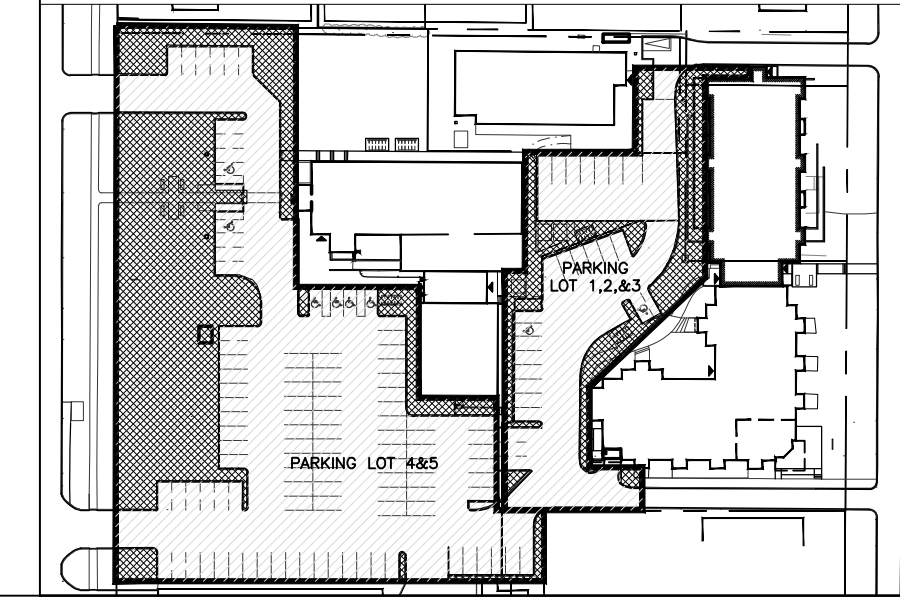

2262 BRAESIDE AVENUE, OTTAWA, ON

DRAWING TITLE
 6,7(3/\$1)

DRAWING NO.
 63

DATE
 4/25/22

PROJECT NO.
 #001-16

SCALE
 AS NOTED

DRAWN BY

3/\$1 12

APPENDIX

D TRANS O-D SURVEY

Alta Vista

Demographic Characteristics

Population	74,770	Actively Travelled	59,190
Employed Population	32,910	Number of Vehicles	37,270
Households	32,590	Area (km ²)	38.5

Occupation Status (age 5+)	Male	Female	Total
Full Time Employed	15,840	12,940	28,780
Part Time Employed	1,660	2,470	4,130
Student	8,130	8,750	16,870
Retiree	6,200	8,840	15,030
Unemployed	1,200	950	2,150
Homemaker	50	2,150	2,200
Other	630	900	1,530
Total:	33,700	36,990	70,700

Traveller Characteristics	Male	Female	Total
Transit Pass Holders	7,620	9,140	16,760
Licensed Drivers	25,060	24,810	49,870
Telecommuters	140	60	200
Trips made by residents	92,440	98,770	191,210

Selected Indicators	
Daily Trips per Person (age 5+)	2.70
Vehicles per Person	0.50
Number of Persons per Household	2.29
Daily Trips per Household	5.87
Vehicles per Household	1.14
Workers per Household	1.01
Population Density (Pop/km ²)	1940

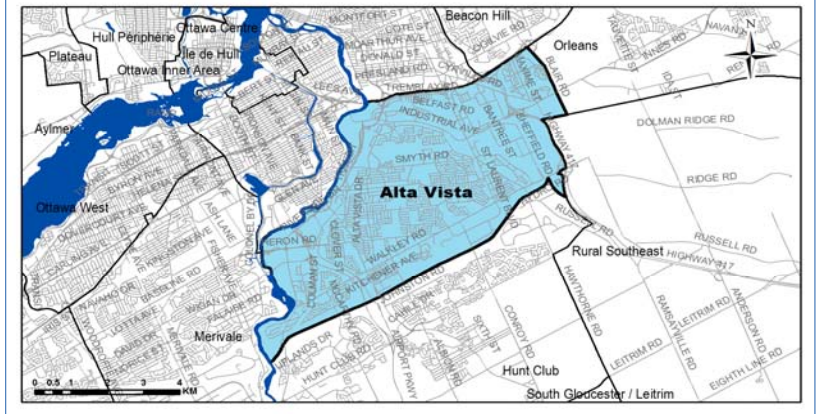

Household Size		
1 person	10,780	33%
2 persons	11,010	34%
3 persons	4,790	15%
4 persons	3,880	12%
5+ persons	2,130	7%
Total:	32,590	100%

Households by Vehicle Availability		
0 vehicles	6,320	19%
1 vehicle	16,930	52%
2 vehicles	8,030	25%
3 vehicles	1,030	3%
4+ vehicles	290	1%
Total:	32,590	100%

Households by Dwelling Type		
Single-detached	12,320	38%
Semi-detached	1,790	5%
Townhouse	4,700	14%
Apartment/Condo	13,780	42%
Total:	32,590	100%

Population

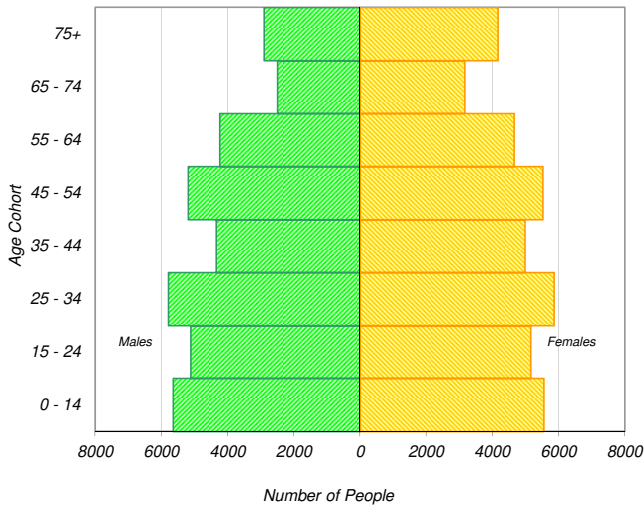

Employed Population

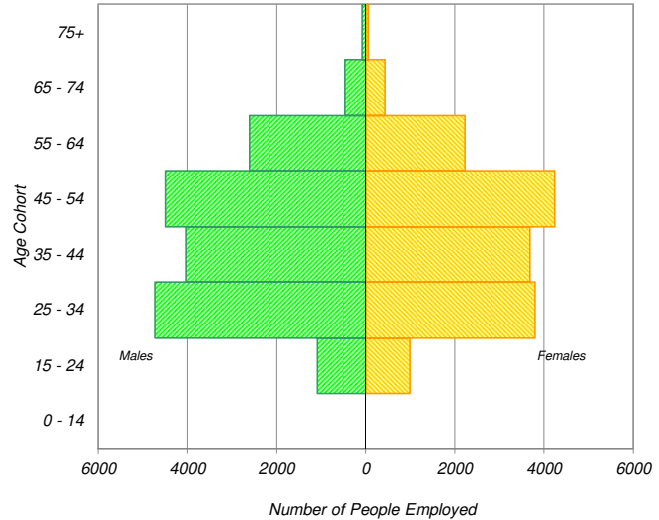

* In 2005 data was only collected for household members aged 11+ therefore these results cannot be compared to the 2011 data.

Travel Patterns

Top Five Origins of Trips to Alta Vista

AM Peak Period

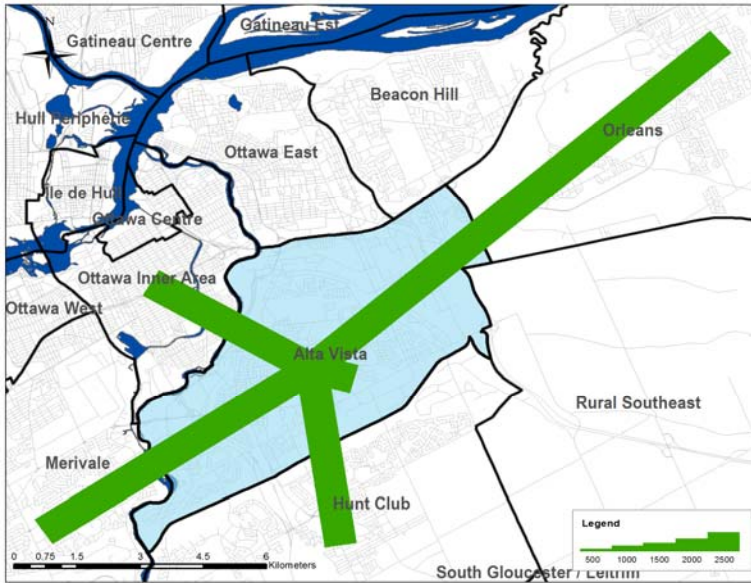

Summary of Trips to and from Alta Vista

AM Peak Period (6:30 - 8:59)

Districts	Destinations of Trips From		Origins of Trips To	
	District	% Total	District	% Total
Ottawa Centre	4,180	10%	680	1%
Ottawa Inner Area	4,970	12%	4,270	7%
Ottawa East	1,940	5%	2,370	4%
Beacon Hill	2,690	7%	1,850	3%
Alta Vista	16,220	39%	16,220	27%
Hunt Club	1,980	5%	7,990	13%
Merivale	3,010	7%	3,690	6%
Ottawa West	1,160	3%	1,550	3%
Bayshore / Cedarview	830	2%	2,330	4%
Orléans	1,050	3%	5,890	10%
Rural East	110	0%	430	1%
Rural Southeast	140	0%	1,550	3%
South Gloucester / Leitrim	160	0%	1,970	3%
South Nepean	460	1%	2,360	4%
Rural Southwest	160	0%	690	1%
Kanata / Stittsville	660	2%	1,810	3%
Rural West	20	0%	180	0%
Île de Hull	710	2%	190	0%
Hull Périphérie	360	1%	420	1%
Plateau	0	0%	680	1%
Aylmer	40	0%	480	1%
Rural Northwest	40	0%	300	1%
Pointe Gatineau	20	0%	740	1%
Gatineau Est	220	1%	270	0%
Rural Northeast	10	0%	320	1%
Buckingham / Masson-Angers	10	0%	70	0%
Ontario Sub-Total:	39,740	97%	55,830	94%
Québec Sub-Total:	1,410	3%	3,470	6%
Total:	41,150	100%	59,300	100%

Trips by Trip Purpose

24 Hours	From District		To District		Within District	
Work or related	22,370	15%	46,540	31%	10,770	13%
School	8,550	6%	8,090	5%	6,440	8%
Shopping	16,500	11%	16,600	11%	14,550	17%
Leisure	11,940	8%	13,340	9%	7,720	9%
Medical	2,990	2%	7,860	5%	2,380	3%
Pick-up / drive passenger	9,390	6%	9,900	6%	6,990	8%
Return Home	75,570	50%	44,070	29%	33,060	39%
Other	4,870	3%	6,050	4%	3,240	4%
Total:	152,180	100%	152,450	100%	85,150	100%

AM Peak (06:30 - 08:59)	From District		To District		Within District	
Work or related	13,920	56%	28,300	66%	5,390	33%
School	5,340	21%	7,330	17%	5,600	35%
Shopping	510	2%	530	1%	320	2%
Leisure	570	2%	990	2%	480	3%
Medical	500	2%	1,760	4%	460	3%
Pick-up / drive passenger	1,790	7%	2,490	6%	2,110	13%
Return Home	1,380	6%	730	2%	910	6%
Other	910	4%	940	2%	930	6%
Total:	24,920	100%	43,070	100%	16,200	100%

PM Peak (15:30 - 17:59)	From District		To District		Within District	
Work or related	820	2%	1,340	5%	740	4%
School	550	1%	90	0%	70	0%
Shopping	3,920	9%	3,630	13%	2,830	14%
Leisure	2,550	6%	2,440	9%	1,580	8%
Medical	260	1%	670	2%	300	2%
Pick-up / drive passenger	3,310	7%	2,550	9%	2,390	12%
Return Home	31,900	72%	15,950	57%	11,310	58%
Other	1,270	3%	1,230	4%	440	2%
Total:	44,580	100%	27,900	100%	19,660	100%

Peak Period (%)	Total:	% of 24 Hours	Within District (%)
24 Hours	389,780		22%
AM Peak Period	84,190	22%	19%
PM Peak Period	92,140	24%	21%

Trips by Primary Travel Mode

24 Hours	From District		To District		Within District	
Auto Driver	92,240	61%	92,670	61%	43,390	51%
Auto Passenger	24,030	16%	24,040	16%	13,430	16%
Transit	27,890	18%	27,220	18%	6,520	8%
Bicycle	2,180	1%	2,110	1%	1,390	2%
Walk	1,440	1%	1,510	1%	15,170	18%
Other	4,420	3%	4,890	3%	5,260	6%
Total:	152,200	100%	152,440	100%	85,160	100%

AM Peak (06:30 - 08:59)	From District		To District		Within District	
Auto Driver	12,430	50%	26,810	62%	6,330	39%
Auto Passenger	3,040	12%	5,100	12%	2,500	15%
Transit	7,540	30%	7,300	17%	1,700	10%
Bicycle	750	3%	750	2%	340	2%
Walk	280	1%	280	1%	3,210	20%
Other	880	4%	2,850	7%	2,140	13%
Total:	24,920	100%	43,090	100%	16,220	100%

PM Peak (15:30 - 17:59)	From District		To District		Within District	
Auto Driver	28,570	64%	15,990	57%	9,640	49%
Auto Passenger	5,930	13%	4,230	15%	3,570	18%
Transit	7,460	17%	6,420	23%	1,500	8%
Bicycle	630	1%	610	2%	470	2%
Walk	340	1%	310	1%	3,280	17%
Other	1,660	4%	340	1%	1,210	6%
Total:	44,590	100%	27,900	100%	19,670	100%

Avg Vehicle Occupancy	From District		To District		Within District	
24 Hours	1.26		1.26		1.31	
AM Peak Period	1.24		1.19		1.39	
PM Peak Period	1.21		1.26		1.37	

Transit Modal Split	From District		To District		Within District	
24 Hours	19%		19%		10%	
AM Peak Period	33%		19%		16%	
PM Peak Period	18%		24%		10%	

APPENDIX

E

DEVELOPMENT
DESIGN
CHECKLIST

TDM-Supportive Development Design and Infrastructure Checklist: *Residential Developments (multi-family or condominium)*

Legend	
REQUIRED	The Official Plan or Zoning By-law provides related guidance that must be followed
BASIC	The measure is generally feasible and effective, and in most cases would benefit the development and its users
BETTER	The measure could maximize support for users of sustainable modes, and optimize development performance

TDM-supportive design & infrastructure measures: <i>Residential developments</i>		Check if completed & add descriptions, explanations or plan/drawing references
1. WALKING & CYCLING: ROUTES		
1.1 Building location & access points		
BASIC	1.1.1 Locate building close to the street, and do not locate parking areas between the street and building entrances	<input checked="" type="checkbox"/>
BASIC	1.1.2 Locate building entrances in order to minimize walking distances to sidewalks and transit stops/stations	<input checked="" type="checkbox"/>
BASIC	1.1.3 Locate building doors and windows to ensure visibility of pedestrians from the building, for their security and comfort	<input checked="" type="checkbox"/>
1.2 Facilities for walking & cycling		
REQUIRED	1.2.1 Provide convenient, direct access to stations or major stops along rapid transit routes within 600 metres; minimize walking distances from buildings to rapid transit; provide pedestrian-friendly, weather-protected (where possible) environment between rapid transit accesses and building entrances; ensure quality linkages from sidewalks through building entrances to integrated stops/stations <i>(see Official Plan policy 4.3.3)</i>	<input type="checkbox"/> N/A
REQUIRED	1.2.2 Provide safe, direct and attractive pedestrian access from public sidewalks to building entrances through such measures as: reducing distances between public sidewalks and major building entrances; providing walkways from public streets to major building entrances; within a site, providing walkways along the front of adjoining buildings, between adjacent buildings, and connecting areas where people may congregate, such as courtyards and transit stops; and providing weather protection through canopies, colonnades, and other design elements wherever possible <i>(see Official Plan policy 4.3.12)</i>	<input checked="" type="checkbox"/> Additional support should be provided within the internal parking lot or on Braeside Avenue for pedestrians attempting to access the sidewalks on Alta Vista Drive and Randall Avenue

TDM-supportive design & infrastructure measures: <i>Residential developments</i>		Check if completed & add descriptions, explanations or plan/drawing references
REQUIRED	1.2.3 Provide sidewalks of smooth, well-drained walking surfaces of contrasting materials or treatments to differentiate pedestrian areas from vehicle areas, and provide marked pedestrian crosswalks at intersection sidewalks (see <i>Official Plan policy 4.3.10</i>)	<input checked="" type="checkbox"/>
REQUIRED	1.2.4 Make sidewalks and open space areas easily accessible through features such as gradual grade transition, depressed curbs at street corners and convenient access to extra-wide parking spaces and ramps (see <i>Official Plan policy 4.3.10</i>)	<input checked="" type="checkbox"/>
REQUIRED	1.2.5 Include adequately spaced inter-block/street cycling and pedestrian connections to facilitate travel by active transportation. Provide links to the existing or planned network of public sidewalks, multi-use pathways and on-road cycle routes. Where public sidewalks and multi-use pathways intersect with roads, consider providing traffic control devices to give priority to cyclists and pedestrians (see <i>Official Plan policy 4.3.11</i>)	<input type="checkbox"/>
BASIC	1.2.6 Provide safe, direct and attractive walking routes from building entrances to nearby transit stops	<input type="checkbox"/>
BASIC	1.2.7 Ensure that walking routes to transit stops are secure, visible, lighted, shaded and wind-protected wherever possible	<input checked="" type="checkbox"/>
BASIC	1.2.8 Design roads used for access or circulation by cyclists using a target operating speed of no more than 30 km/h, or provide a separated cycling facility	<input type="checkbox"/> N/A
1.3 Amenities for walking & cycling		
BASIC	1.3.1 Provide lighting, landscaping and benches along walking and cycling routes between building entrances and streets, sidewalks and trails	<input type="checkbox"/>
BASIC	1.3.2 Provide wayfinding signage for site access (where required, e.g. when multiple buildings or entrances exist) and egress (where warranted, such as when directions to reach transit stops/stations, trails or other common destinations are not obvious)	<input type="checkbox"/>

TDM-supportive design & infrastructure measures: <i>Residential developments</i>		Check if completed & add descriptions, explanations or plan/drawing references
2. WALKING & CYCLING: END-OF-TRIP FACILITIES		
2.1 Bicycle parking		
REQUIRED	2.1.1 Provide bicycle parking in highly visible and lighted areas, sheltered from the weather wherever possible (see <i>Official Plan policy 4.3.6</i>)	<input checked="" type="checkbox"/>
REQUIRED	2.1.2 Provide the number of bicycle parking spaces specified for various land uses in different parts of Ottawa; provide convenient access to main entrances or well-used areas (see <i>Zoning By-law Section 111</i>)	<input checked="" type="checkbox"/>
REQUIRED	2.1.3 Ensure that bicycle parking spaces and access aisles meet minimum dimensions; that no more than 50% of spaces are vertical spaces; and that parking racks are securely anchored (see <i>Zoning By-law Section 111</i>)	<input checked="" type="checkbox"/>
BASIC	2.1.4 Provide bicycle parking spaces equivalent to the expected number of resident-owned bicycles, plus the expected peak number of visitor cyclists	<input checked="" type="checkbox"/>
2.2 Secure bicycle parking		
REQUIRED	2.2.1 Where more than 50 bicycle parking spaces are provided for a single residential building, locate at least 25% of spaces within a building/structure, a secure area (e.g. supervised parking lot or enclosure) or bicycle lockers (see <i>Zoning By-law Section 111</i>)	<input type="checkbox"/> N/A
BETTER	2.2.2 Provide secure bicycle parking spaces equivalent to at least the number of units at condominiums or multi-family residential developments	<input type="checkbox"/>
2.3 Bicycle repair station		
BETTER	2.3.1 Provide a permanent bike repair station, with commonly used tools and an air pump, adjacent to the main bicycle parking area (or secure bicycle parking area, if provided)	<input type="checkbox"/>
3. TRANSIT		
3.1 Customer amenities		
BASIC	3.1.1 Provide shelters, lighting and benches at any on-site transit stops	<input type="checkbox"/> N/A
BASIC	3.1.2 Where the site abuts an off-site transit stop and insufficient space exists for a transit shelter in the public right-of-way, protect land for a shelter and/or install a shelter	<input type="checkbox"/> N/A
BETTER	3.1.3 Provide a secure and comfortable interior waiting area by integrating any on-site transit stops into the building	<input type="checkbox"/> N/A

TDM-supportive design & infrastructure measures: <i>Residential developments</i>		Check if completed & add descriptions, explanations or plan/drawing references
4. RIDESHARING		
4.1 Pick-up & drop-off facilities		
BASIC	4.1.1 Provide a designated area for carpool drivers (plus taxis and ride-hailing services) to drop off or pick up passengers without using fire lanes or other no-stopping zones	<input type="checkbox"/>
5. CARSHARING & BIKESHARING		
5.1 Carshare parking spaces		
BETTER	5.1.1 Provide up to three carshare parking spaces in an R3, R4 or R5 Zone for specified residential uses (see <i>Zoning By-law Section 94</i>)	<input type="checkbox"/> N/A
5.2 Bikeshare station location		
BETTER	5.2.1 Provide a designated bikeshare station area near a major building entrance, preferably lighted and sheltered with a direct walkway connection	<input type="checkbox"/>
6. PARKING		
6.1 Number of parking spaces		
REQUIRED	6.1.1 Do not provide more parking than permitted by zoning, nor less than required by zoning, unless a variance is being applied for	<input checked="" type="checkbox"/>
BASIC	6.1.2 Provide parking for long-term and short-term users that is consistent with mode share targets, considering the potential for visitors to use off-site public parking	<input type="checkbox"/>
BASIC	6.1.3 Where a site features more than one use, provide shared parking and reduce the cumulative number of parking spaces accordingly (see <i>Zoning By-law Section 104</i>)	<input type="checkbox"/>
BETTER	6.1.4 Reduce the minimum number of parking spaces required by zoning by one space for each 13 square metres of gross floor area provided as shower rooms, change rooms, locker rooms and other facilities for cyclists in conjunction with bicycle parking (see <i>Zoning By-law Section 111</i>)	<input type="checkbox"/>
6.2 Separate long-term & short-term parking areas		
BETTER	6.2.1 Provide separate areas for short-term and long-term parking (using signage or physical barriers) to permit access controls and simplify enforcement (i.e. to discourage residents from parking in visitor spaces, and vice versa)	<input type="checkbox"/>

APPENDIX

F

AUTOTURN
ANALYSIS

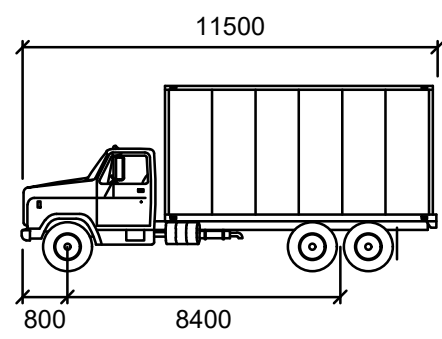
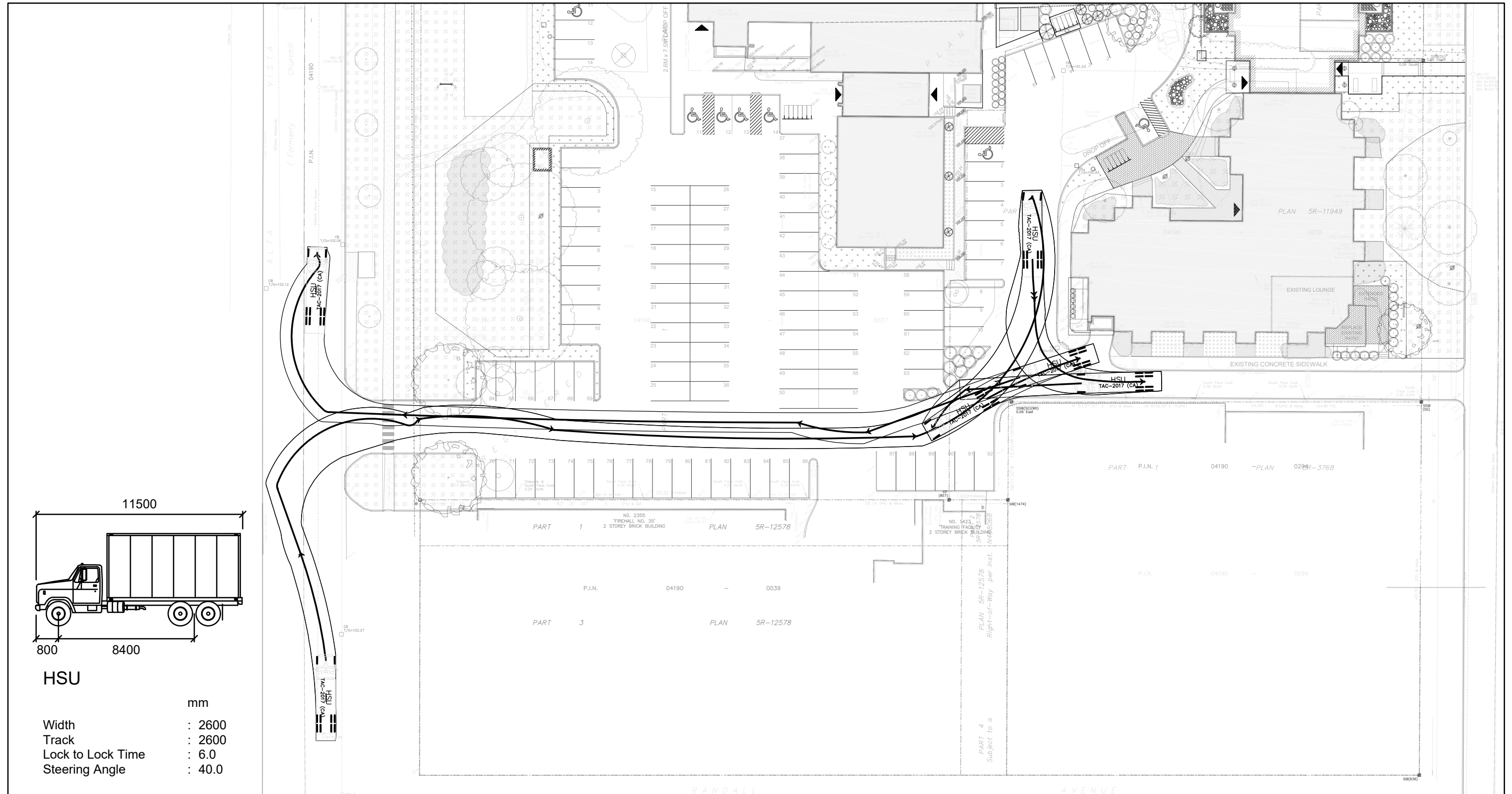

HSU

mm

Width : 2600

Track : 2600

Lock to Lock Time : 6.0

Steering Angle : 40.0



2611 QUEENSVIEW DRIVE
OTTAWA ONTARIO CANADA K2B 8K2
TEL.: 613-829-2800 | WWW.WSP.COM

A		2022-04-29	TRANSPORTATION IMPACT ASSESSMENT
IS.	RV.	DATE	DESCRIPTION

SEAL:

CLIENT:
ELLWOOD HOUSE LTD.

CLIENT REF. #: --

PROJECT:
**2262 BRAESIDE AVENUE
TRANSPORTATION IMPACT ASSESSMENT**

PROJECT NO:
20M-01221-00

DESIGNED BY:
JP/NS

DRAWN BY:
NS

CHECKED BY:
KH

DRAWING NO:
TT-01

DATE / DATE:
2022-04-29

SCALE:
1:500

TITLE:
TRUCK TURNING MOVEMENT PLAN

DISCIPLINE:
TRANSPORTATION PLANNING

ISSUE:
A

DATE OF: **2022-04-29**

RV. #
0

APPENDIX

G MMLOS SEGMENT CALCULATIONS

Multi-Modal Level of Service - Segments Form

Consultant	WSP
Scenario	Future Total
Comments	

Project	2262 Braeside Avenue TIA
Date	February 12 2022

SEGMENTS		Street A	Alta Vista Dr 1	Braeside Ave 2	Section 3	Section 4	Section 5	Section 6	Section 7	Section 8	Section 9
Pedestrian	Sidewalk Width	F	1.8 m	no sidewalk							
	Boulevard Width		0.5 - 2 m	n/a							
	Avg Daily Curb Lane Traffic Volume		> 3000	≤ 3000							
	Operating Speed		> 30 to 50 km/h	> 30 to 50 km/h							
	On-Street Parking		no	no							
	Exposure to Traffic PLoS		C	F	-	-	-	-	-	-	-
	Effective Sidewalk Width		1.5 m	1.2 m							
	Pedestrian Volume		250 ped/hr	250 ped/hr							
Crowding PLoS	B	B	-	-	-	-	-	-	-		
Level of Service	C	F	-	-	-	-	-	-	-		
Bicycle	Type of Cycling Facility	B	Curbside Bike Lane	Mixed Traffic							
	Number of Travel Lanes		≤ 1 each direction	≤ 2 (no centreline)							
	Operating Speed		≤ 50 km/h	>40 to <50 km/h							
	# of Lanes & Operating Speed LoS		A	B	-	-	-	-	-	-	
	Bike Lane (+ Parking Lane) Width		≥1.5 to <1.8 m								
	Bike Lane Width LoS		B	-	-	-	-	-	-	-	
	Bike Lane Blockages		Rare								
	Blockage LoS		A	-	-	-	-	-	-	-	
	Median Refuge Width (no median = < 1.8 m)		< 1.8 m refuge	< 1.8 m refuge							
	No. of Lanes at Unsignalized Crossing		≤ 3 lanes	≤ 3 lanes							
	Sidestreet Operating Speed		≤ 40 km/h	≤ 40 km/h							
Unsignalized Crossing - Lowest LoS	A	A	-	-	-	-	-	-			
Level of Service	B	B	-	-	-	-	-	-			
Transit	Facility Type	D	Mixed Traffic								
	Friction or Ratio Transit:Posted Speed		Vt/Vp ≥ 0.8								
	Level of Service		D	-	-	-	-	-	-		
Truck	Truck Lane Width	-									
	Travel Lanes per Direction										
Level of Service	-	-	-	-	-	-	-	-			

APPENDIX

H

TDM

CHECKLIST

TDM Measures Checklist:
Residential Developments (multi-family, condominium or subdivision)

Legend	
BASIC	The measure is generally feasible and effective, and in most cases would benefit the development and its users
BETTER	The measure could maximize support for users of sustainable modes, and optimize development performance
★	The measure is one of the most dependably effective tools to encourage the use of sustainable modes

TDM measures: Residential developments		Check if proposed & add descriptions
1. TDM PROGRAM MANAGEMENT		
1.1 Program coordinator		
BASIC	★ 1.1.1 Designate an internal coordinator, or contract with an external coordinator	<input type="checkbox"/>
1.2 Travel surveys		
BETTER	1.2.1 Conduct periodic surveys to identify travel-related behaviours, attitudes, challenges and solutions, and to track progress	<input type="checkbox"/>
2. WALKING AND CYCLING		
2.1 Information on walking/cycling routes & destinations		
BASIC	2.1.1 Display local area maps with walking/cycling access routes and key destinations at major entrances (<i>multi-family, condominium</i>)	<input checked="" type="checkbox"/>
2.2 Bicycle skills training		
BETTER	2.2.1 Offer on-site cycling courses for residents, or subsidize off-site courses	<input type="checkbox"/>

TDM measures: <i>Residential developments</i>		Check if proposed & add descriptions
3. TRANSIT		
3.1 Transit information		
BASIC	3.1.1 Display relevant transit schedules and route maps at entrances (<i>multi-family, condominium</i>)	<input checked="" type="checkbox"/>
BETTER	3.1.2 Provide real-time arrival information display at entrances (<i>multi-family, condominium</i>)	<input type="checkbox"/>
3.2 Transit fare incentives		
BASIC ★	3.2.1 Offer PRESTO cards preloaded with one monthly transit pass on residence purchase/move-in, to encourage residents to use transit	<input checked="" type="checkbox"/>
BETTER	3.2.2 Offer at least one year of free monthly transit passes on residence purchase/move-in	<input type="checkbox"/>
3.3 Enhanced public transit service		
BETTER ★	3.3.1 Contract with OC Transpo to provide early transit services until regular services are warranted by occupancy levels (<i>subdivision</i>)	<input type="checkbox"/>
3.4 Private transit service		
BETTER	3.4.1 Provide shuttle service for seniors homes or lifestyle communities (e.g. scheduled mall or supermarket runs)	<input checked="" type="checkbox"/>
4. CARSHARING & BIKESHARING		
4.1 Bikeshare stations & memberships		
BETTER	4.1.1 Contract with provider to install on-site bikeshare station (<i>multi-family</i>)	<input type="checkbox"/>
BETTER	4.1.2 Provide residents with bikeshare memberships, either free or subsidized (<i>multi-family</i>)	<input type="checkbox"/>
4.2 Carshare vehicles & memberships		
BETTER	4.2.1 Contract with provider to install on-site carshare vehicles and promote their use by residents	<input type="checkbox"/>
BETTER	4.2.2 Provide residents with carshare memberships, either free or subsidized	<input type="checkbox"/>
5. PARKING		
5.1 Priced parking		
BASIC ★	5.1.1 Unbundle parking cost from purchase price (<i>condominium</i>)	<input type="checkbox"/>
BASIC ★	5.1.2 Unbundle parking cost from monthly rent (<i>multi-family</i>)	<input type="checkbox"/>

TDM measures: <i>Residential developments</i>		Check if proposed & add descriptions
6. TDM MARKETING & COMMUNICATIONS		
6.1 Multimodal travel information		
BASIC ★	6.1.1 Provide a multimodal travel option information package to new residents	<input checked="" type="checkbox"/>
6.2 Personalized trip planning		
BETTER ★	6.2.1 Offer personalized trip planning to new residents	<input type="checkbox"/>