

# SERVICING BRIEF & STORMWATER MANAGEMENT REPORT

Ellwood House Extension  
2262 Braeside Avenue  
& Site Improvements  
2262-2270 Braeside Avenue & 2345 Alta Vista Drive  
Ottawa, Ontario

Report No. 21028

October 25, 2021  
Revised April 14, 2022  
Revised August 10, 2022  
Revised November 30, 2022

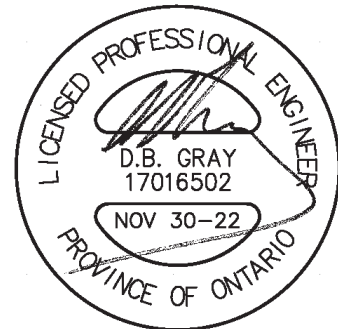

NOT VALID UNLESS  
SIGNED & DATED



*Stormwater Management - Grading & Drainage - Storm & Sanitary Sewers - Watermains*

700 Long Point Circle  
Ottawa, ON K1T 4E9

613-425-8044  
d.gray@dbgrayengineering.com

# SERVICING BRIEF & STORMWATER MANAGEMENT REPORT

Ellwood House Extension  
2262 Braeside Avenue  
& Site Improvements  
2262-2270 Braeside Avenue & 2345 Alta Vista Drive  
Ottawa, Ontario

The subject site, located in the Alta Vista area of Ottawa, is 1.27 hectares in area and is comprised of three properties: 2345 Alta Vista Drive and 2262 and 2270 Braeside Avenue. 2345 Alta Vista Drive is 8,496 sq.m. in area and is occupied by St. Thomas the Apostle Anglican Church and Braeside House (a residence for adults with developmental disabilities). Ellwood House (a seniors apartment building) is located on a 3,000 sq.m. property at 2270 Braeside Avenue; and 2262 Braeside Avenue (1,233 sq.m.) currently has a single detached dwelling (a rectory) that will be demolished.

An extension of an Ellwood House is proposed. The extension will be a 38-unit, three-storey (four-level including basement apartments) building. This report describes the services of 2262 Braeside Avenue. This report also describes the modifications to existing services (that are required to accommodate the proposed building) and addresses the stormwater management requirements of the entire site.

This report forms part of the stormwater management design for the proposed development. Refer to drawings C-1 to C-9 also prepared by D. B. Gray Engineering Inc.

## WATER SUPPLY FOR FIREFIGHTING:

There is an existing municipal fire hydrant in the Braeside Avenue municipal road right-of-way located across the street from the proposed building approximately 28 m unobstructed distance from the east entrance to the proposed building and about 60 m unobstructed distance from the north entrance. There is also an existing private on-site fire hydrant located adjacent to the northwest corner of the proposed building approximately 23 m unobstructed distance to the north entrance and about 68 m unobstructed distance to the north entrance. Since the existing fire hydrants are less than the maximum 90 m permitted, an additional on-site fire hydrant is not required. There are two other existing municipal fire hydrants in the vicinity. One hydrant is located at the northwest corner of the Clontarf Avenue / Braeside Avenue intersection about 78 m unobstructed distance to the proposed building. The other hydrant is located in the Randall Avenue road right-of-way, just west of the intersection with Braeside Avenue, about 146 m unobstructed distance to the proposed building. The Braeside Avenue municipal hydrants are Class A hydrants (colour coded green). The Randall Avenue municipal hydrant is a Class AA (colour coded blue).

As per Technical Bulletin ISTB-2021-03, on private property, where pipe size is not affected, the flow required for firefighting is to be calculated as per the Ontario Building Code (OBC). A fire demand of 3,600 L/min (60 L/s) at 138 kPa is required as per "Required Minimum Water Supply Flow Rate" as calculated using the Ontario Building Code - Appendix A - Article A-3.2.5.7 "Water Supply For Fire Fighting".

The boundary conditions (based on the city's computer model of the municipal water distribution system) for a 60 L/s fire flow were requested from the City. However, the boundary conditions revealed that available flow at 20 psi (138 kPa) is only 50 L/s. A Multi-Hydrant Analysis (with two hydrants open) was requested, and it was determined that Braeside Avenue and Clontarf Avenue hydrants flowing *"concurrently will be able to deliver the 60 L/s required fire flow while maintaining 20psi residual at both hydrants."* Therefore, there is an adequate water supply for firefighting.

As per City of Ottawa Technical Bulletin ISTB-2018-02, the aggregate fire flow of all contributing fire hydrants within 150 m of the building can be used to supply the required fire flow. The Class A Braeside Avenue fire hydrant is within 75 m and can contribute 3,800 L/min (63 L/s) as per Table 1 of ISTB-2018-02. The Class A Clontarf Avenue fire hydrant is between 75 m and 150 m and can contribute 2,850 L/min (47.5 L/s) as per Table 1 of ISTB-2018-02. However, as per the boundary conditions, we assume that only 3,600 L/s (60 L/s) is available between the two of them. The Class AA Randall Avenue hydrant, being between 75 and 150 m, can contribute 3,800 L/min (63 L/s) (as per Table 1 of ISTB-2018-02). Therefore, the aggregate flow from all hydrants in the vicinity is 7,400 L/min (123 L/s), which is greater than the required fire flow of 60 L/s.

The proposed building conflicts with the private watermain serving the on-site hydrant and will be decommissioned. A new watermain is proposed. The existing fire hydrant will remain approximately at its current location and will connect to the new watermain. The existing 150 mm watermain and fire hydrant lead is about 47 m in length from the City watermain to the fire hydrant. The proposed watermain will be about 50 m. Since the City water pressure is low, and to compensate for the longer length, about 40 m of the new watermain will be 200 mm in diameter.

#### WATER SERVICE:

Thirty-eight one-bedroom apartment units are proposed. Based on Technical Bulletin ISTB-2018-02 and the City of Ottawa Water Distribution Design Guidelines (Table 4.1 & Table 4.2: one-bedroom apartment units / 1.4 person per unit; two-bedroom apartment units / 2.1 persons per unit; and 280 L/person/day) and Ministry of the Environment Design Guidelines for peaking factors (Table 3-3) the daily average flow is 0.2 L/s with a maximum daily and maximum hourly demand of 1.5 and 2.2 L/s respectively.

To determine water pressure under these demands, boundary conditions, based on the City of Ottawa computer simulation of the water distribution system, at the subject location, are required. Based on the boundary conditions received from the City, the minimum HGL (hydraulic grade line) is 123.8 m, and the maximum is 132.3 m. With these HGLs the water

pressure at the water meter is calculated to vary from 235 kPa to 318 kPa (34 to 46 psi). As per City of Ottawa Design Guidelines: *“In accordance with MOE Guidelines, the distribution system shall be sized so that under maximum hourly demand conditions the pressures are not less than 276 kPa (40 psi).”* Since the water pressure under the maximum hourly demand is 235 kPa (34 psi), the existing City water distribution adjacent to the subject location does not meet this guideline; a booster pump will likely be required for the domestic water supply.

Based on the AWWA water flow demand curve, and a water pressure at the meter of 276 kPa (40 psi), the peak demand for the building is expected to be 2.7 L/s (164 L/min / 43 USgpm). The AWWA method calculates the instantaneous demand and is used to size the water service. This peak demand will produce an acceptable velocity of 1.4 m/s in the proposed 50 mm water service connection (up to 2.4 m/s is acceptable). The water service will connect to the 150 mm municipal watermain in Braeside Avenue.

The existing 150 mm water service for Braeside House currently connects to the existing private 150 mm watermain that will be decommissioned. This existing service will connect to the new private watermain. This will have a positive impact on water pressure and flow at Braeside House since much of the new private watermain has increased in size from 150mm to 200 mm in diameter.

The proposed building conflicts with the water service for the church (which connects directly to the 150 mm City watermain in Braeside Avenue). The size of the existing service is 25 mm where it enters the building, but part of the service may be up to 50 mm in diameter. About 52 m of the existing water service will be decommissioned. A new 50 mm water service is proposed. It will be 30.5 m in length and will connect to the new private water main. This will have a positive impact on water pressure and flow at the church since the new water service is about 21 m shorter and may be larger.

#### SANITARY SERVICE:

Based on the City of Ottawa Sewer Design Guidelines for a residential property (Technical Bulletin ISTB-2018-01, Figure 4.3: 38 one-bedroom apartment units / 1.4 person per unit; 280 l/person/day; and a 3.2 peaking factor); and based on a 0.33 L/s/ha infiltration flow; the post development flow is calculated to be 0.59 L/s. (The existing dwelling has a design flow of 0.08 L/s.) This flow will be adequately handled by the proposed sanitary sewer service connections (150 mm at 1% - 15.89 L/s capacity) since, at the design flow, it will only be about 3% full.

The proposed 150 mm sanitary service connection will connect to the 225 mm municipal combined sewer in Braeside Avenue which, with about a 1.30% slope, has a capacity of 51.20 L/s. (The next downstream segment, with a 1.71% slope, has a greater capacity of 58.72 L/s.) The 0.51 L/s increase in sanitary flows contributing to the existing 225 mm combined sewer is expected to have an acceptable impact.

The proposed building conflicts with the existing 150 mm sanitary sewer service for Braeside House (which connects directly to the 225 mm City sanitary sewer in Braeside Avenue). A

new 200 mm private sanitary sewer is proposed. This existing service will connect to the new private sanitary sewer (and part of the service will be decommissioned).

The proposed building also conflicts with the sanitary sewer service for the church (which also connects directly to the 225 mm City sanitary sewer in Braeside Avenue). This existing service will connect to the new private sanitary sewer (and part of the service will be decommissioned).

## STORMWATER MANAGEMENT:

The two main areas that are being re-developed are being controlled (both quality and quantity controlled). A new storm sewer system is proposed for the area that drains towards Alta Vista Drive; and an existing storm sewer system that drains to Braeside Avenue will be modified.

### Water Quality:

The Rideau Valley Conservation Authority (RVCA) has advised that; *“Based on the downstream stormwater outlet to a watercourse being just around 2 km, water quality treatment of ‘enhanced’ (80% TSS removal) would be the appropriate water quality target.”*

### Alta Vista Drive Drainage Area (972 sq.m.):

To meet the water quality target of 80% TSS removal an oil/grit separator (OGS) manhole (manhole MH-5) is proposed to be located downstream of the inlet control device (ICD). Specifically, a Contech Engineered Solutions CDS Model 2015-4 has been selected to achieve a minimum 80% TSS removal. Based on software supplied by the manufacturer, the CDS Model 2015-4 will remove approximately 91% of TSS from the runoff produced by the drainage area. Output from the manufacturer’s software is attached to this report. The CDS Model 2015-4 has a sediment capacity of 0.7 cubic metres and an oil/debris capacity of 232 litres.

### Braeside Avenue Drainage Area (8,228 sq.m.):

To meet the water quality target of 80% TSS removal an oil/grit separator (OGS) manhole (manhole MH-17) is proposed to be located at the most downstream end of the system. Specifically, a Contech Engineered Solutions CDS Model 2020-5 has been selected to achieve a minimum 80% TSS removal. Based on software supplied by the manufacturer, the CDS Model 2020-5 will remove approximately 83% of TSS from the runoff produced by the drainage area. Output from the manufacturer’s software is attached to this report. The CDS Model 2020-5 has a sediment capacity of 1.1 cubic metres and an oil/debris capacity of 376 litres.

An erosion and sediment control plan has been developed to be implemented during construction, (see drawing C-4 and notes 2.1 to 2.6 on drawing C-5). In summary: to filter out construction sediment; a silt fence barrier will be installed; sediment capture filter sock

inserts will be installed in all new catch basins as they are installed; and any material deposited on a public road will be removed at the end of each day.

Water Quantity:

Alta Vista Drive Drainage Area (972 sq.m.):

The stormwater management criteria for quantity control are to control the post development peak flows for the 5-year and 100-year storm events to peak flows during the 2-year storm event using a pre-development runoff coefficient or runoff coefficient of 0.5, whichever is less. It is calculated that the pre-development conditions reflect a 5-year runoff coefficient of 0.43. Therefore, based on a runoff coefficient of 0.43, a 10-minute time of concentration; and using the Rational Method; the maximum allowable release rate is 8.90 L/s for all storm events. The Modified Rational Method is used to calculate the required storage volume. The runoff coefficients for the 100-year event are increased by 25% to maximum 1.00.

Stormwater will be stored in the parking area above catch basins.

Drainage Area I (Uncontrolled Flow – 66 sq.m.):

The runoff from the entrance to the site will be allowed to flow uncontrolled. The flow from this area is calculated at 10 minutes concentration.

	100-year	5-year
Maximum flow rate:	3.28 L/s	1.72 L/s

Drainage Area II (906 sq.m.):

An inlet control device (ICD) located at the outlet pipe of catch basin / manhole CB/MH-3 will control the release of stormwater from this drainage area. The ICD will restrict the flow and force the stormwater to back up onto the asphalted surface above three catch basins (CB-1, CB/MH-2 and CB/MH-3). The ICD shall be a Hydrovex "VHV Vertical Vortex Flow Regulator" (or approved equal) and shall be sized by the manufacturer for a discharge rate of 6.00 L/s at 2.29 m head (6 L/s is lowest flowrate recommended by the City of Ottawa). It is calculated that an orifice area of 4,418 sq.mm. (75 mm in diameter) and a discharge coefficient of 0.203 will restrict the outflow rate to 6.00 L/s at 2.29 m. Based on this orifice the maximum outflow rate for the 5-year storm event is also 6.00 L/s at 2.29 m.

Drainage Area II:

	100-year	5-year
Maximum release rate:	6.00 L/s	5.94 L/s
Maximum water elevation:	102.55 m	102.51 m
Maximum stored volume:	28.37 cu.m.	10.75 cu.m.

The Entire Alta Vista Drive Drainage Area:

	100-year	5-year
Pre-development flow rate:	23.90 L/s	12.08 L/s
Maximum allowable release rate:	8.90 L/s	8.90 L/s
Maximum release rate:	9.28 L/s	7.66 L/s
Maximum stored volume:	28.37 cu.m.	10.75 cu.m.

The pre-development flow rate is calculated to be 23.90 L/s during the 100-year event; and 12.08 L/s during the 5-year event. Therefore, using the smallest ICD recommended by the City, the maximum post-development release rate for the 100-year storm event is calculated to be about 4% more than the maximum allowable; however, it is 61% less than the pre-development flow rate. The maximum post-development release rate for the 5-year storm event is calculated to be 14% less than the maximum allowable and 37% less than the pre-development flow rate.

A proposed storm sewer system will connect to existing 375 mm storm sewer in Alta Vista Drive. The unrestricted flowrate resulting from two-year storm event will produce a peak flow of 15.60 L/s which will be adequately handled by the proposed storm sewer systems with the pipe segments varying from 10 to 39% of capacity.

The stormwater flows contributing to the 300 mm municipal storm sewer in Alta Vista Drive is expected to have a positive impact given that post development flows are 37% less than pre-development.

**Braeside Avenue Drainage Area (2,044 sq.m.):**

The stormwater management criteria for quantity control are to control the post development peak flows for the 5-year and 100-year storm events to peak flows during the 2-year storm event using a pre-development runoff coefficient or runoff coefficient of 0.5, whichever is less. It is calculated that the pre-development conditions reflect a 5-year runoff coefficient of 0.44. Therefore, based on a runoff coefficient of 0.44, a 10-minute time of concentration; and using the Rational Method; the maximum allowable release rate is 19.10 L/s for all storm events. The Modified Rational Method is used to calculate the required storage volume. The runoff coefficients for the 100-year event are increased by 25% to maximum 1.00.

Stormwater will be stored in underground chambers and in the parking area above a catch basin.

**Drainage Area III (Uncontrolled Flow – 318 sq.m.):**

The runoff from around the perimeter will be allowed to flow uncontrolled. The flow from this area is calculated at 10 minutes concentration.

	100-year	5-year
Maximum flow rate:	8.08 L/s	4.09 L/s

**Drainage Area IV (1,029 sq.m.):**

An inlet control device (ICD) located at the outlet pipe of catch basin / manhole CB/MH-16 will control the release of stormwater from this drainage area. The ICD will restrict the flow and force the stormwater to back up onto underground chamber. Specifically, ten Soleno Hydrostor HS75 Chambers (or approved equal) surrounded by clear stone and wrapped in a geotextile fabric will be used. The ICD shall be a Hydrovex "VHV Vertical Vortex Flow Regulator" (or approved equal) and shall be sized by the manufacturer for a discharge rate of 6.00 L/s at 1.65 m head (6 L/s is lowest flowrate recommended by the City of Ottawa). It is calculated that an orifice area of

4,418 sq.mm. (75 mm in diameter) and a discharge coefficient of 0.239 will restrict the outflow rate to 6.00 L/s at 1.65 m. Based on this orifice the maximum outflow rate for the 5-year storm event is 4.74 L/s at 1.00 m.

	100-year	5-year
Maximum release rate:	6.00 L/s	4.73 L/s
Maximum water elevation:	99.16 m	98.59 m
Maximum stored volume:	21.89 cu.m.	15.00 cu.m.

Drainage Area Va + Vb (1,074 sq.m.)

(Drainage Area Va 697 sq.m. controlled) (Drainage Area Vb 377 sq.m. uncontrolled):

A previously developed area, 377 sq.m. in area, does not need to be controlled but is account for in the calculations. An inlet control device (ICD) located at the outlet pipe of catch basin / manhole CB/MH-7 will control the release of stormwater from this drainage area. The ICD will restrict the flow and force the stormwater to back up onto underground chamber and the asphalted surface above catch basin CB/MH-7. Specifically, three Soleno Hydrostor HS180 Chambers (or approved equal) surrounded by clear stone and wrapped in a geotextile fabric will be used. The storage requirement was calculated by ignoring the uncontrolled drainage area. The uncontrolled drainage area was then included in the calculations, and since the storage area was not increased the excess water overflows out the entrance towards Braeside Avenue (8.64 L/s during the 100-year event; and no overflow during the 5-year event). The ICD shall be a Hydrovex "VHV Vertical Vortex Flow Regulator" (or approved equal) and shall be sized by the manufacturer for a discharge rate of 6.00 L/s at 2.77 m head (6 L/s is lowest flowrate recommended by the City of Ottawa). It is calculated that an orifice area of 4,418 sq.mm. (75 mm in diameter) and a discharge coefficient of 0.184 will restrict the outflow rate to 6.00 L/s at 2.77 m. Based on this orifice the maximum outflow rate for the 5-year storm event is 5.92 L/s at 2.69 m (including the uncontrolled area).

Drainage Area Va (excluding uncontrolled area: Drainage Area IIb):

	100-year	5-year
Maximum release rate:	6.00 L/s	4.52 L/s
Maximum water elevation:	100.66 m	99.46 m
Maximum stored volume:	22.43 cu.m.	10.17 cu.m.

Drainage Area Va + Vb (including uncontrolled area):

	100-year	5-year
Maximum ICD release rate:	6.00 L/s	5.92 L/s
Maximum overflow release rate:	<u>8.64 L/s</u>	<u>0.00 L/s</u>
Total Maximum release rate:	14.64 L/s	5.92 L/s
Maximum water elevation:	100.66 m	100.58 m
Maximum stored volume:	22.64 cu.m.	17.02 cu.m.

The Entire Braeside Avenue Drainage Area (excluding uncontrolled area):

	100-year	5-year
Pre-development flow rate:	51.20 L/s	25.91 L/s
Maximum allowable release rate:	19.10 L/s	19.10 L/s
Maximum release rate:	20.08 L/s	13.35 L/s
Maximum stored volume:	55.72 cu.m.	25.17 cu.m.



The pre-development flow rate is calculated to be 51.20 L/s during the 100-year event; and 25.91 L/s during the 5-year event. Therefore, using the smallest ICDs recommended by the City, the maximum post-development release rate for the 100-year storm event is calculated to be about 5% more than the maximum allowable; however, it is 61% less than the pre-development flow rate. The maximum post-development release rate for the 5-year storm event is calculated to be 30% less than the maximum allowable and 48% less than the pre-development flow rate.

The proposed building conflicts with an existing storm sewer system which serves Braeside House, the church and east part of the site. It connects directly to the 375 mm City storm sewer in Braeside Avenue. A new 375 mm private storm sewer system is proposed. The unrestricted flowrate resulting from two-year storm event will produce a peak flow of 102.73 L/s, which will be adequately handled by the proposed storm sewer systems with the last segment being at 100% of its capacity.

The stormwater flows contributing to the 375 mm municipal storm sewer in Braeside Avenue is expected to have a positive impact given that post development flows are less than pre-development.

Ministry of Environment, Conservation and Parks (MECP) Environmental Compliance Approval (ECA):

The proposed storm and sanitary sewers cross multiple properties; however, it is effectively one property; therefore, an ECA is not expected to be required for the proposed sewers and stormwater management facility.

## CONCLUSIONS:

1. There is an existing private on-site fire hydrant; an additional on-site fire hydrant is not required.
2. There is an adequate water supply for firefighting
3. The aggregate flow from three contributing fire hydrants within 150 m of the proposed building is greater than the required fire flow.
4. The water pressure is calculated to vary from 235 kPa to 318 kPa (34 to 46 psi); and since the water pressure under the maximum hourly demand is less than 40 psi, the existing City water distribution adjacent to the subject location does not meet this guideline; a booster pump will likely be required for the domestic water supply.
5. The peak water demand will produce an acceptable velocity of 1.4 m/s in the proposed 50 mm water service connection (up to 2.4 m/s is acceptable).
6. The expected sanitary sewage flow rate will be adequately handled by the proposed sanitary sewer service connection.
7. The increase sanitary flow contributing to the existing municipal sanitary sewer is expected to have an acceptable impact.
8. The stormwater in the two main areas that are being re-developed are being controlled (both quality and quantity controlled).
9. To meet the water quality target of 80% TSS removal two oil/grit separator (OGS) manholes (manholes MH-5 and MH-16) are proposed.
10. An erosion and sediment control plan has been developed to be implemented during construction.
11. A new storm sewer system is proposed for the area that drains towards Alta Vista Drive; and an existing storm sewer system that drains to Braeside Avenue will be modified.
12. The stormwater management criteria for quantity control for both the Alta Vista Drive and Braeside Avenue drainage areas are to control the post development peak flows for the 5-year and 100-year storm events to peak flows during the 2-year storm event using a pre-development runoff coefficient or runoff coefficient of 0.5, whichever is less.
13. In the Alta Vista Drive drainage area, using the smallest ICD recommended by the City, the maximum post-development release rate for the 100-year storm event is calculated to be more than the maximum allowable; however, it is 61% less than the pre-development flow rate. The maximum post-development release rate for the 5-year storm event is calculated to be 14% less than the maximum allowable and 37% less than the pre-development flow rate.

14. In the Braeside Avenue drainage area, using the smallest ICD recommended by the City, the maximum post-development release rate for the 100-year storm event is calculated to be more than the maximum allowable; however, it is 40% less than the pre-development flow rate. The maximum post-development release rate for the 5-year storm event is calculated to be 2% less than the maximum allowable and 28% less than the pre-development flow rate.
15. The unrestricted flowrate resulting from two-year storm event will be adequately by the proposed storm sewer system connecting to the Alta Vista Drive storm sewer.
16. The unrestricted flowrate resulting from two-year storm event will be adequately by the proposed storm sewer system connecting to the Braeside Avenue storm sewer.
17. The stormwater flows contributing to the 300 mm municipal storm sewer in Alta Vista Drive is expected to have a positive impact given that the flow is bring restricted.
18. The stormwater flows contributing to the 375 mm municipal storm sewer in Braeside Avenue is expected to have a positive impact given that the flow is bring restricted.
19. A MECP ECA is not expected to be required

14-Oct-21

Ellwood House Extension  
 38-Unit 3-Storey Apartment Building  
 2262 Braeside Avenue  
 Ottawa, Ontario

Water Supply for Fire-Fighting Calculations:

As per "Required Minimum Water Supply Flow Rate" as calculated using the Ontario Building Code - Appendix A - Article A-3.2.5.7 "Water Supply For Fire Fighting".

Fire Protection Water Supply  $Q = KVS_{Tot}$

$$S_{Tot} = 1.0 + S_{Side1} + S_{Side2} + S_{Side3} + S_{Side4}$$

Spatial Coefficient	Exposure Distance m	
$S_{Side1}$	0.33	6.8 (to north property line)
$S_{Side2}$	0.00	17.5 (to east to center line of road)
$S_{Side3}$	0.00	10.0 (south - 2 hour firewall)
$S_{Side4}$	0.00	14.5 (to south property line)
$S_{Tot}$	1.33	Need not exceed 2

K (Water Supply Coefficient)

18 As per A-3.2.5.7. Table 1 (Group C Occupancy / Combustible construction with fire separations and fire resistance ratings as per OBC 3.2.2.)

V (Building Volume)

	Area sq.m.	Average Height m	Volume cu.m.
Third Floor	630.5	2.64	1665
Second Floor	630.5	2.64	1665
Ground Floor	630.5	2.64	1665
			4994 cu.m.

$$Q = KVS_{Tot}$$

$$Q = 119,096 \text{ L}$$

Required Minimum Water Supply Flow Rate 3,600 L/min 60 L/sec  
 (As per A-3.2.5.7. Table 2)

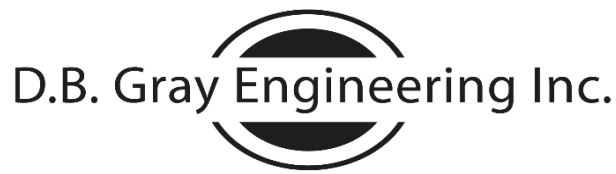

Stormwater Management - Grading & Drainage - Storm & Sanitary Sewers - Watermains  
 700 Long Point Circle  
 Ottawa, Ontario K1T 4E9  
 613-425-8044  
 d.gray@dbgrayengineering.com

14-Oct-21

## Ellwood House Extension 38-Unit 3-Storey Apartment Building 2262 Braeside Avenue Ottawa, Ontario

### Water Demand

	Number of Units	Persons Per Unit	Population
APARTMENTS:			
Bachelor	0	1.4	0
1 Bedroom:	38	1.4	53
2 Bedroom:	0	2.1	0
3 Bedroom:	0	3.1	0
Average Apartment:	0	1.8	0
<b>TOTAL:</b>	<b>38</b>		<b>53</b>

APARTMENTS:

DAILY AVERAGE:	280 litres / person / day			
	10.3 L/min	0.2 L/s	2.7 USgpm	
MAXIMUM DAILY DEMAND:	8.6 (Peaking Factor for a equivalent population of 53: Table 3-3 MOE Design Guidelines for Drinking-Water Systems)			
	89.1 L/min	1.5 L/s	24 USgpm	
MAXIMUM HOURLY DEMAND:	13.0 (Peaking Factor for a equivalent population of 53: Table 3-3 MOE Design Guidelines for Drinking-Water Systems)			
	134.1 L/min	2.2 L/s	35 USgpm	

Elevation of Water Meter:	99.86 m ASL		
Finish Floor Elevation:	98.96 m ASL		
		Static Pressure at Water Meter	
MINIMUM HGL:	123.8 m ASL	34 psi	235 kPa
MAXIMUM HGL:	132.3 m ASL	46 psi	318 kPa



Douglas Gray <d.gray@dbgrayengineering.com>

---

## RE: Boundary Condition Request - 2262 Braeside Ave

1 message

---

**Sharif, Golam** <sharif.sharif@ottawa.ca>  
To: Douglas Gray <d.gray@dbgrayengineering.com>  
Cc: Ryan Faith <r.faith@dbgrayengineering.com>

Wed, Feb 23, 2022 at 3:26 PM

Hi Doug,

Here is the response I received from the water modelling group:

“Hydrant 370027H035 is much closer to the site than Hydrant 370027H039. Measuring from Hydrant 370027H039 to the proposed building along the fire access roads may exceed 150m.

Flowing Hydrants 370027H037 and 370027H035 concurrently will be able to deliver the 60 L/s required fire flow while maintaining 20psi residual at both hydrants. Please note as per previous boundary condition provided, 50 L/s is the available fire flow at 20psi at the watermain in front of the site.”

Therefore, please confirm the unobstructed distance from the hydrants and update the design as needed. Thanks.

Sharif

---

**From:** Douglas Gray <d.gray@dbgrayengineering.com>  
**Sent:** February 15, 2022 12:26 PM  
**To:** Sharif, Golam <sharif.sharif@ottawa.ca>  
**Cc:** Ryan Faith <r.faith@dbgrayengineering.com>  
**Subject:** Re: Boundary Condition Request - 2262 Braeside Ave

**CAUTION: This email originated from an External Sender. Please do not click links or open attachments unless you recognize the source.**

**ATTENTION : Ce courriel provient d'un expéditeur externe. Ne cliquez sur aucun lien et n'ouvrez pas de pièce jointe, excepté si vous connaissez l'expéditeur.**

Hi Sharif

As you know we require a Fire Flow + Max Day of 61.5 L/s but only 50 L/s is available at 20 psi from the 150mm watermain in Braeside Ave.

Please request a Multi-Hydrant Analysis with two hydrants open: The hydrant in front of 2269 Braeside Ave (Hydrant ID 370027H037) plus the hydrant in front of 1438 Randall Ave (Hydrant ID 370027H039). (The Randall Ave hydrant is located about 146 m unobstructed distance to the proposed building.)

As per our previous request:

Average daily demand: 0.2 L/s.

Maximum daily demand: 1.5 L/s.

Maximum hourly daily demand: 2.2 L/s

Fire Flow demand: 60 L/s (based on OBC method)

Fire Flow + Max Day: 61.5 L/s

Thanks, Doug

*Stormwater Management - Grading & Drainage - Storm & Sanitary Sewers - Watermains*

**700 Long Point Circle**

**Tel: 613-425-8044**

Ottawa, Ontario K1T 4E9

[d.gray@dbgrayengineering.com](mailto:d.gray@dbgrayengineering.com)

On Wed, Oct 20, 2021 at 11:51 AM Sharif, Golam <[sharif.sharif@ottawa.ca](mailto:sharif.sharif@ottawa.ca)> wrote:

Hi Doug,

Here is the requested boundary condition:

The following are boundary conditions, HGL, for hydraulic analysis at 2262 Braeside Avenue (zone 2W2C) assumed to be connected to the 152 mm on Braeside Avenue (see attached PDF for location).

Minimum HGL: 123.8 m

Maximum HGL: 132.3 m

Available flow at 20 psi: 50 L/s, assuming a ground elevation of 99.8 m.

These are for current conditions and are based on computer model simulation.

*Disclaimer: The boundary condition information is based on current operation of the city water distribution system. The computer model simulation is based on the best information available at the time. The operation of the water distribution system can change on a regular basis, resulting in a variation in boundary conditions. The physical properties of watermains deteriorate over time, as such must be assumed in the absence of actual field test data. The variation in physical watermain properties can therefore alter the results of the computer model simulation.*

Regards,

Sharif

---

**From:** Douglas Gray <d.gray@dbgrayengineering.com>  
**Sent:** October 14, 2021 5:35 PM  
**To:** Sharif, Golam <sharif.sharif@ottawa.ca>  
**Cc:** Ryan Faith <r.fait@dbgrayengineering.com>  
**Subject:** Boundary Condition Request - 2262 Braeside Ave

**CAUTION: This email originated from an External Sender. Please do not click links or open attachments unless you recognize the source.**

**ATTENTION : Ce courriel provient d'un expéditeur externe. Ne cliquez sur aucun lien et n'ouvrez pas de pièce jointe, excepté si vous connaissez l'expéditeur.**

Hi Sharif

Please provide the boundary conditions at 2262 Braeside Ave. We have calculated the following expected demands for a 3-Storey 38-unit apartment building.

Average daily demand: 0.2 L/s.

Maximum daily demand: 1.5 L/s.

Maximum hourly daily demand: 2.2 L/s

Fire Flow demand: 250.0 L/s (based on FUS method)

Fire Flow + Max Day: 2501.5 L/s

16



Fire Flow demand: 60 L/s (based on OBC method)

Fire Flow + Max Day: 61.5 L/s

Calculations are attached.

Thanks, Doug

This e-mail originates from the City of Ottawa e-mail system. Any distribution, use or copying of this e-mail or the information it contains by other than the intended recipient(s) is unauthorized. Thank you.

Le présent courriel a été expédié par le système de courriels de la Ville d'Ottawa. Toute distribution, utilisation ou reproduction du courriel ou des renseignements qui s'y trouvent par une personne autre que son destinataire prévu est interdite. Je vous remercie de votre collaboration.

This e-mail originates from the City of Ottawa e-mail system. Any distribution, use or copying of this e-mail or the information it contains by other than the intended recipient(s) is unauthorized. Thank you.

Le présent courriel a été expédié par le système de courriels de la Ville d'Ottawa. Toute distribution, utilisation ou reproduction du courriel ou des renseignements qui s'y trouvent par une personne autre que son destinataire prévu est interdite. Je vous remercie de votre collaboration.

# Boundary Conditions for 2262 Braeside Avenue

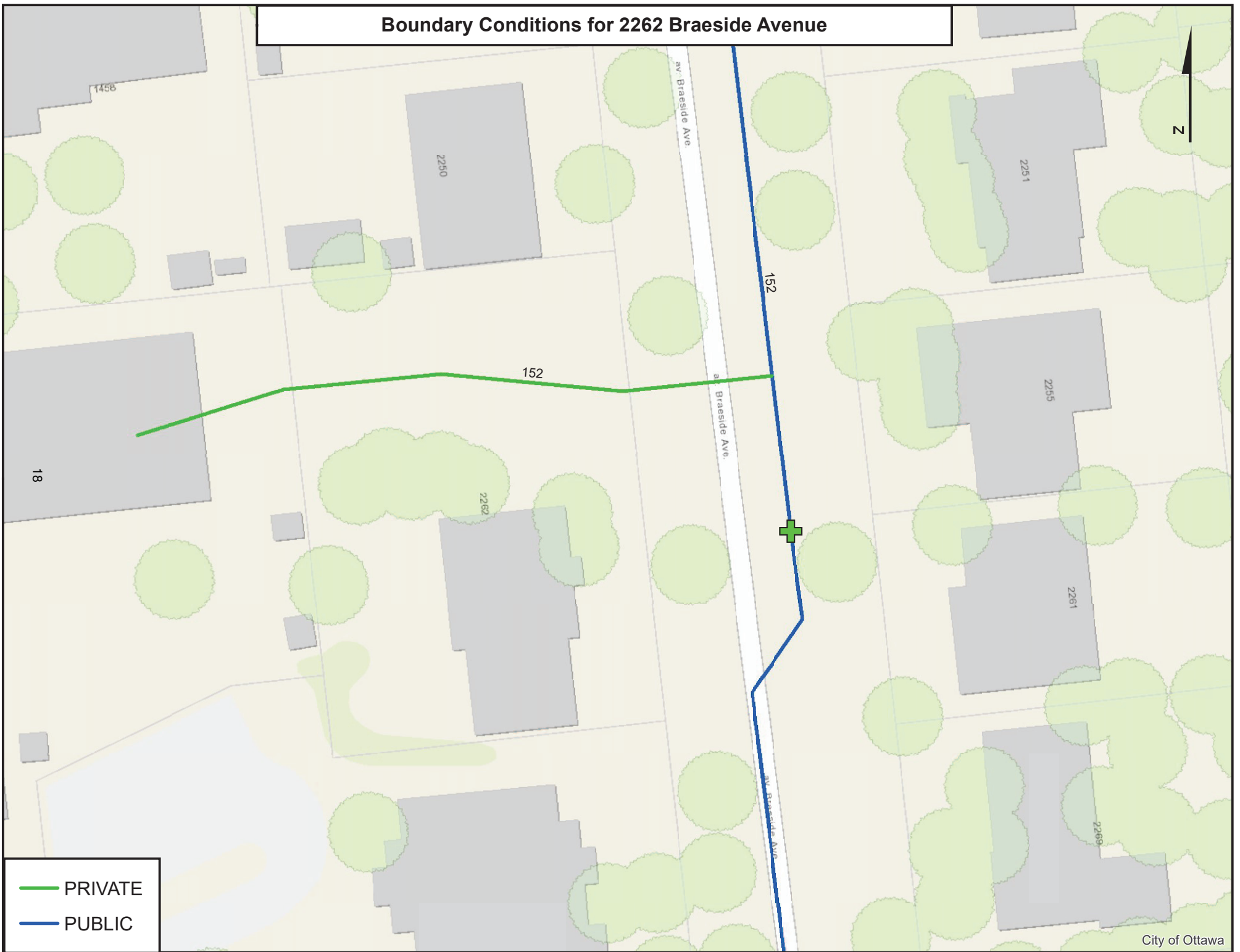

- PRIVATE
- PUBLIC

## Ellwood House Extension 38-Unit 3-Storey Apartment Building 2262 Braeside Avenue Ottawa, Ontario

### PEAK WATER DEMAND

WATER FIXTURE VALUE  
 (Table 4-2 AWWA Manual M22)

	No.	F.V.	Total
Bathtub	0	8	0
Toilet - Tank	38	6	228
Toilet - Flush Valve	0	24	0
Lavatory	38	1.5	57.0
Bidet	0	2	0
Urinal - Wall Flush Valve	0	10	0
Shower	38	2.5	95.0
Kitchen Sink	38	1.8	68.4
Dishwasher	38	1.3	49.4
Clothes Washer	4	3	12
Commercial Sink	0	4	0
Janitor Sink	2	4	8
Commercial Dishwasher	0	4	0
Commercial Clothes Washer	0	4	0
Hose 1/2 in	0	5	0
Hose 3/4 in	0	12	0
			517.8

Peak Demand (Figure 4-2 or 4-3 AWWA M22)	48	USgpm		
Pressure @ Meter	276	kPa	40	psi
Pressure Factor (Table 4-1 AWWA M22)	0.80			
Peak Demand	38	USgpm		
Irrigation - Hose 1/2 in	1		5	USgpm (includes pressure factor)
TOTAL PEAK DEMAND	164	L/min	43	USgpm
			2.7	L/s
Nominal Size	2.0	in	50	mm
	4.6	ft/s	1.4	m/s



Stormwater Management - Grading & Drainage - Storm & Sanitary Sewers - Watermains  
 700 Long Point Circle 613-425-8044  
 Ottawa, Ontario d.gray@dbgrayengineering.com

### SANITARY SEWER DESIGN FORM

Average Daily Flows  
 Residential: 280 L / capita / day  
 Commercial: 28000 L / ha / day  
 Institutional: 28000 L / ha / day  
 Light Industrial: 35000 L / ha / day  
 Heavy Industrial: 55000 L / ha / day

Peaking Factor:  
 Residential (Harmon Equation):  $1 + \frac{14}{4 + P^{0.5}}$   
 P = Population / 1000  
 Harmon Correction Factor: 0.8  
 Commercial & Institutional: 1.5 If contribution > 20%  
 Commercial & Institutional: 1 If contribution < 20%  
 Industrial: As per Ottawa Guidelines Appendix 4-B

Project: 2262 Braeside Avenue  
 Designed By: D.B.G.  
 April 14, 2022  
 Page: 1 of 1  
 n = 0.013

Infiltration Allowance: 0.33 l / s / ha

20

Location		Section							Cumulative Residential		Section Non-Residential			Cumulative					Sewer Data						Comments			
		Single Family ppu = 3.4	Semi / Townhouse ppu = 2.7	Duplex / Triplex ppu = 2.3	Apartment (average) ppu = 1.8	Apartment (1 Bed) ppu = 1.4	Apartment (2 Bed) ppu = 2.1	Apartment (3 Bed) ppu = 3.1	Area (ha)	Pop.	Peaking Factor	Area (ha)	Flow (L/ha/day)	Peaking Factor	Flow (L/s)	Area (ha)	Sewage Flow (L/s)	Infiltration Flow (L/s)	Total Flow (L/s)	Material	Actual Diameter (mm)	Nominal Diameter (mm)	Slope (%)	Length (m)		Capacity (L/s)	Velocity (m/s)	Ratio Q/Qfull
From	To	No. of Units	No. of Units	No. of Units	No. of Units	No. of Units	No. of Units	No. of Units																				
Existing Dwelling																												
Existing Dwelling	Existing 225 SAN	1							0.1233	3.4	3.20					0.1233	0.04	0.04	0.08									
Proposed Apartment Building																												
Proposed Building	Existing 225 SAN					38			0.1233	53.2	3.20					0.1233	0.55	0.04	0.59	PVC	152.4	150	2.00	18.0	22.47	1.23	0.03	
Existing 225 SAN in Braeside Avenue																												
																					225.0	225	1.30		51.20	1.29		
Existing 225 SAN in Braeside Avenue - 1st Downstream Segment																												
																					225.0	225	1.71		58.72	1.48		



Ryan Faith &lt;r.faith@dbgrayengineering.com&gt;

---

**RE: RVCA Stormwater Management Comments - 2270 Braeside Avenue**

1 message

---

**Jamie Batchelor** <jamie.batchelor@rvca.ca>  
To: Ryan Faith <r.faith@dbgrayengineering.com>  
Cc: Douglas Gray <d.gray@dbgrayengineering.com>

Mon, Oct 18, 2021 at 2:56 PM

Good Afternoon Ryan,

Based on the downstream stormwater outlet to a watercourse being just around 2 km, water quality treatment of 'enhanced' (80% TSS removal) would be the appropriate water quality target.

Jamie Batchelor, MCIP, RPP

Planner, ext. 1191

[Jamie.batchelor@rvca.ca](mailto:jamie.batchelor@rvca.ca)



3889 Rideau Valley Drive  
PO Box 599, Manotick ON K4M 1A5  
T 613-692-3571 | 1-800-267-3504 F 613-692-0831 | [www.rvca.ca](http://www.rvca.ca)

This message may contain information that is privileged or confidential and is intended to be for the use of the individual(s) or entity named above. This material may contain confidential or personal information which may be subject to the provisions of the Municipal *Freedom of Information & Protection of Privacy Act*. If you are not the intended recipient of this e-mail, any use, review, revision, retransmission, distribution, dissemination, copying, printing or otherwise use of, or taking of any action in reliance upon this e-mail, is strictly prohibited. If you have received this e-mail in error, please contact the sender and delete the original and any copy of the e-mail and any printout thereof, immediately. Your cooperation is appreciated.

---

**From:** Ryan Faith <r.faith@dbgrayengineering.com>  
**Sent:** Thursday, October 14, 2021 10:30 AM  
**To:** Jamie Batchelor <jamie.batchelor@rvca.ca>  
**Cc:** Douglas Gray <d.gray@dbgrayengineering.com>  
**Subject:** RVCA Stormwater Management Comments - 2270 Braeside Avenue

Hi Jamie,

We are working on a proposed 3 storey addition to the existing Ellwood House at [2270 Braeside Avenue](#) in Ottawa. Some of the existing parking lots are being reconfigured and new parking is proposed.

Please comment on the stormwater management for the site.

I have attached a site plan for your reference.

Thanks,

Ryan Faith

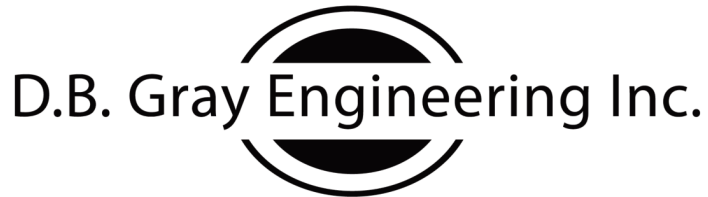

*Stormwater Management - Grading & Drainage - Storm & Sanitary Sewers - Watermains*

700 Long Point Circle

613-425-8044

Ottawa, Ontario

r.faith@dbgrayengineering.com



Douglas Gray <d.gray@dbgrayengineering.com>

**RE: CDS Sizing - Ellwood house, 2270 Braeside Ave**

**Natalie W** <natalie@echelonenvironmental.ca>  
To: Laurent Brosseau <l.brosseau@dbgrayengineering.com>  
Cc: Douglas Gray <d.gray@dbgrayengineering.com>

Wed, Jul 20, 2022 at 4:29 PM

Hi Laurent,

Thank you for the sizing request! The recommended CDS models for Area 1 and 2 (I took the liberty to name them OGS 1 and 2 respectively) are a PMSU2015-4, and a PMSU2020-5 unit. Please find attached our CDS TSS removal calculations with sample cut sheet drawings included for your files.

If you have any questions, please feel free to contact our office at your convenience.

Best Regards,

Natalie

Natalie Wong, P.Eng.

Echelon Environmental Inc.

Office Address

Mailing Address

55 Albert Street – Suite 200

5694 Hwy #7 East - Suite 354

Markham, ON

Markham, ON

L3P 2T4

L3P 0E3

PH: 905-948-0000

FAX: 905-948-0577

MOBILE: 416-476-8936

EMAIL: Natalie@echelonenvironmental.ca

**From:** Laurent Brosseau <l.brosseau@dbgrayengineering.com>

**Sent:** July-20-22 4:18 PM

**To:** Natalie W <natalie@echelonenvironmental.ca>

**Cc:** Douglas Gray <d.gray@dbgrayengineering.com>

**Subject:** CDS Sizing - Ellwood house, 2270 Braeside Ave

Hi Natalie,

We are working on a project at [2270 Braeside Ave \(Ottawa, Ontario\)](#). Could you please size the required CDS for 80% TSS removal for each of the following drainage areas?

Area 1

Roof Area: 71 sq.m

Hard Area: 829 sq.m

Soft Area: 62 sq.m

Total Catchment Area: 965 sq.m

C: 0.85

And

Area 2

Roof Area: 2454 sq.m

Hard Area: 3923 sq.m

Soft Area: 1851 sq.m

Total Catchment Area: 8228 sq.m

C: 0.74

Thanks,

--

Laurent Brosseau

**D. B. GRAY ENGINEERING INC.**

*Stormwater Management - Grading & Drainage - Storm & Sanitary Sewers - Watermains*

700 Long Point Circle

Tel: 613-425-8044

Ottawa, Ontario K1T 4E9

[l.brosseau@dbgrayengineering.com](mailto:l.brosseau@dbgrayengineering.com)



**2270 Braeside Ave - CDS TSSR (20-Jul-22).pdf**

909K





**CDS ESTIMATED NET ANNUAL SOLIDS LOAD REDUCTION  
BASED ON THE RATIONAL RAINFALL METHOD  
BASED ON A FINE PARTICLE SIZE DISTRIBUTION**



<b>Project Name:</b> 2270 Braeside Avenue	<b>Engineer:</b> D. B. Gray Engineering
<b>Location:</b> Ottawa, ON	<b>Contact:</b> L Brosseau
<b>OGS #:</b> OGS 1	<b>Report Date:</b> 20-Jul-22

<b>Area</b> 0.0965 ha	<b>Rainfall Station #</b> 215	
<b>Weighted C</b> 0.85	<b>Particle Size Distribution</b> FINE	
<b>CDS Model</b> 2015-4	<b>CDS Treatment Capacity</b> 20 l/s	

<u>Rainfall Intensity<sup>1</sup></u> (mm/hr)	<u>Percent Rainfall Volume<sup>1</sup></u>	<u>Cumulative Rainfall Volume</u>	<u>Total Flowrate (l/s)</u>	<u>Treated Flowrate (l/s)</u>	<u>Operating Rate (%)</u>	<u>Removal Efficiency (%)</u>	<u>Incremental Removal (%)</u>
0.5	9.2%	9.2%	0.1	0.1	0.6	98.7	9.0
1.0	10.6%	19.8%	0.2	0.2	1.2	98.5	10.5
1.5	9.9%	29.7%	0.3	0.3	1.7	98.4	9.7
2.0	8.4%	38.1%	0.5	0.5	2.3	98.2	8.2
2.5	7.7%	45.8%	0.6	0.6	2.9	98.0	7.5
3.0	5.9%	51.7%	0.7	0.7	3.5	97.9	5.8
3.5	4.4%	56.1%	0.8	0.8	4.0	97.7	4.3
4.0	4.7%	60.7%	0.9	0.9	4.6	97.5	4.5
4.5	3.3%	64.0%	1.0	1.0	5.2	97.4	3.2
5.0	3.0%	67.1%	1.1	1.1	5.8	97.2	2.9
6.0	5.4%	72.4%	1.4	1.4	6.9	96.9	5.2
7.0	4.4%	76.8%	1.6	1.6	8.1	96.5	4.2
8.0	3.5%	80.3%	1.8	1.8	9.2	96.2	3.4
9.0	2.8%	83.2%	2.1	2.1	10.4	95.9	2.7
10.0	2.2%	85.3%	2.3	2.3	11.5	95.6	2.1
15.0	7.0%	92.3%	3.4	3.4	17.3	93.9	6.6
20.0	4.5%	96.9%	4.6	4.6	23.0	92.3	4.2
25.0	1.4%	98.3%	5.7	5.7	28.8	90.6	1.3
30.0	0.7%	99.0%	6.8	6.8	34.5	89.0	0.6
35.0	0.5%	99.5%	8.0	8.0	40.3	87.3	0.4
40.0	0.5%	100.0%	9.1	9.1	46.0	85.7	0.5
45.0	0.0%	100.0%	10.3	10.3	51.8	84.0	0.0
50.0	0.0%	100.0%	11.4	11.4	57.5	82.4	0.0

97.0

Removal Efficiency Adjustment<sup>2</sup> = 6.5%  
**Predicted Net Annual Load Removal Efficiency = 90.5%**  
**Predicted % Annual Rainfall Treated = 100.0%**

1 - Based on 42 years of hourly rainfall data from Canadian Station 6105976, Ottawa ON  
 2 - Reduction due to use of 60-minute data for a site that has a time of concentration less than 30-minutes.  
 3 - CDS Efficiency based on testing conducted at the University of Central Florida  
 4 - CDS design flowrate and scaling based on standard manufacturer model & product specifications

**CDS PMSU2015-4-C DESIGN NOTES**

THE STANDARD CDS PMSU2015-4-C CONFIGURATION IS SHOWN. ALTERNATE CONFIGURATIONS ARE AVAILABLE AND ARE LISTED BELOW. SOME CONFIGURATIONS MAY BE COMBINED TO SUIT SITE REQUIREMENTS.

**CONFIGURATION DESCRIPTION**

GRATED INLET ONLY (NO INLET PIPE)
GRATED INLET WITH INLET PIPE OR PIPES
CURB INLET ONLY (NO INLET PIPE)
CURB INLET WITH INLET PIPE OR PIPES
CUSTOMIZABLE SUMP DEPTH AVAILABLE
ANTI-FLOTATION DESIGN AVAILABLE UPON REQUEST

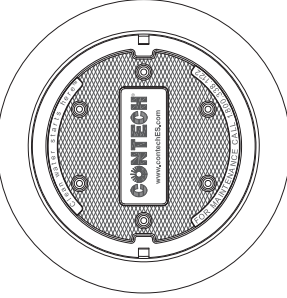

**FRAME AND COVER**  
(DIAMETER VARIES)  
N.T.S.

SITE SPECIFIC DATA REQUIREMENTS	
STRUCTURE ID	
WATER QUALITY FLOW RATE (CFS OR US)	*
PEAK FLOW RATE (CFS OR US)	*
RETURN PERIOD OF PEAK FLOW (YRS)	*
SCREEN APERTURE (2400 OR 4700)	*
PIPE DATA: I.E. MATERIAL	DIAMETER
INLET PIPE 1	*
INLET PIPE 2	*
OUTLET PIPE	*
RIM ELEVATION	*
ANTI-FLOTATION BALLAST	WIDTH
	HEIGHT
NOTES/SPECIAL REQUIREMENTS:	
* PER ENGINEER OF RECORD	

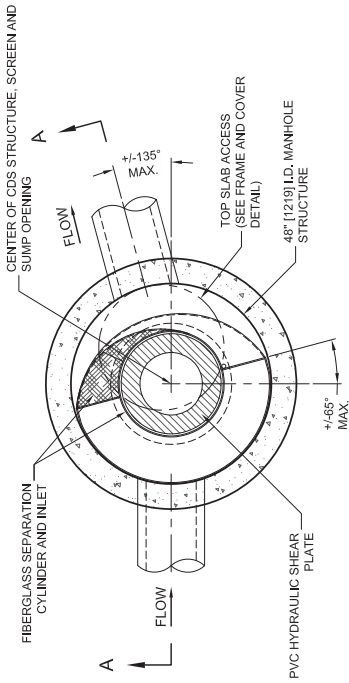

**PLAN VIEW B-B**  
N.T.S.

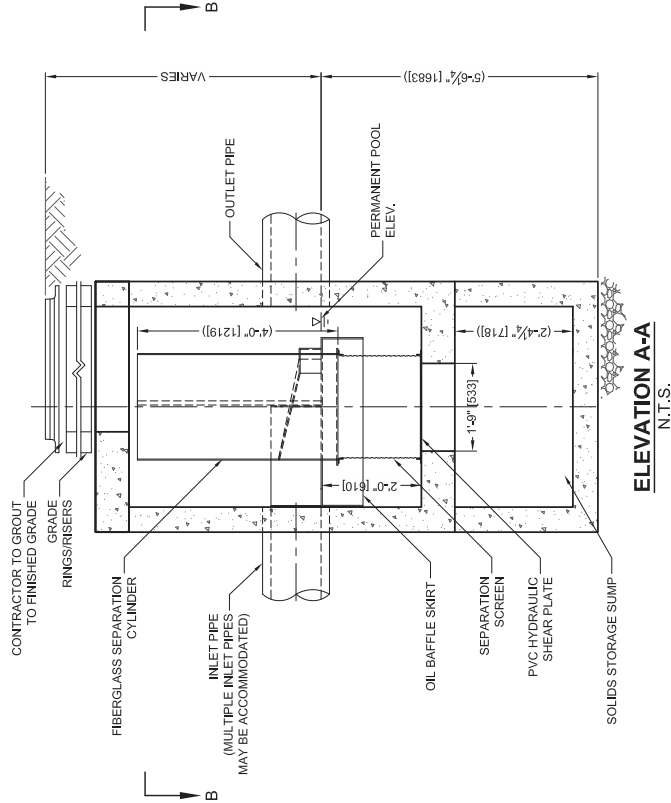

**ELEVATION A-A**  
N.T.S.

- GENERAL NOTES**
- CONTECH TO PROVIDE ALL MATERIALS UNLESS NOTED OTHERWISE.
  - CONTECH TO PROVIDE ALL DIMENSIONS UNLESS NOTED OTHERWISE.
  - FOR FABRICATION DRAWINGS WITH DETAILED STRUCTURE DIMENSIONS AND WEIGHTS, PLEASE CONTACT YOUR CONTECH ENGINEER.
  - SOLUTIONS LLC REPRESENTATIVE: [www.contech.com](http://www.contech.com)
  - CDS WATER QUALITY STRUCTURE SHALL BE IN ACCORDANCE WITH ALL DESIGN DATA AND INFORMATION CONTAINED IN THIS DRAWING.
  - STRUCTURE SHALL MEET AASHTO HS20 AND CASTINGS SHALL MEET HS20 (AASHTO M 306) LOAD RATING, ASSUMING GROUNDWATER ELEVATION AT OR BELOW THE OUTLET PIPE INVERT ELEVATION. ENGINEER OF RECORD TO CONFIRM ACTUAL GROUNDWATER ELEVATION.
  - PVC HYDRAULIC SHEAR PLATE IS PLACED ON SHELF AT BOTTOM OF SCREEN CYLINDER. REMOVE AND REPLACE AS NECESSARY DURING MAINTENANCE CLEANING.
- INSTALLATION NOTES**
- ANY SUB-BASE, BACKFILL DEPTH, AND/OR ANTI-FLOTATION PROVISIONS ARE SITE-SPECIFIC DESIGN CONSIDERATIONS AND SHALL BE SPECIFIED BY ENGINEER OF RECORD.
  - LIFTING AND LOWERING EQUIPMENT WITH SUFFICIENT LIFTING AND REACH CAPACITY TO LIFT AND SET THE CDS MANHOLE STRUCTURE (LIFTING JACKS) SHALL BE PROVIDED.
  - CONTRACTOR TO ADD JOINT SEALANT BETWEEN ALL STRUCTURE SECTIONS, AND ASSEMBLY STRUCTURE.
  - CONTRACTOR TO PROVIDE, INSTALL, AND GROUT PIPES. MATCH PIPE INVERTS WITH ELEVATIONS SHOWN.
  - CONTRACTOR TO TAKE APPROPRIATE MEASURES TO ASSURE UNIT IS WATER TIGHT, HOLDING WATER TO FLOWLINE INVERT MINIMUM. IT IS SUGGESTED THAT ALL JOINTS BELOW PIPE INVERTS ARE GROUTED.

CDS PMSU2015-4-C  
INLINE CDS  
STANDARD DETAIL

**CONTECH**  
ENGINEERED SOLUTIONS LLC  
[www.contech.com](http://www.contech.com)  
9025 Centre Pointe Dr., Suite 400, West Chester, OH 45069  
800-338-1122 513-842-7000 513-842-7883 FAX





**CDS ESTIMATED NET ANNUAL SOLIDS LOAD REDUCTION  
BASED ON THE RATIONAL RAINFALL METHOD  
BASED ON A FINE PARTICLE SIZE DISTRIBUTION**



<b>Project Name:</b> 2270 Braeside Avenue	<b>Engineer:</b> D. B. Gray Engineering
<b>Location:</b> Ottawa, ON	<b>Contact:</b> L Brosseau
<b>OGS #:</b> OGS 2	<b>Report Date:</b> 20-Jul-22

<b>Area</b> 0.8228 ha	<b>Rainfall Station #</b> 215	
<b>Weighted C</b> 0.74	<b>Particle Size Distribution</b> FINE	
<b>CDS Model</b> 2020	<b>CDS Treatment Capacity</b> 31 l/s	

<u>Rainfall Intensity<sup>1</sup></u> (mm/hr)	<u>Percent Rainfall Volume<sup>1</sup></u>	<u>Cumulative Rainfall Volume</u>	<u>Total Flowrate</u> (l/s)	<u>Treated Flowrate (l/s)</u>	<u>Operating Rate (%)</u>	<u>Removal Efficiency (%)</u>	<u>Incremental Removal (%)</u>
0.5	9.2%	9.2%	0.8	0.8	2.7	98.1	9.0
1.0	10.6%	19.8%	1.7	1.7	5.4	97.3	10.3
1.5	9.9%	29.7%	2.5	2.5	8.2	96.5	9.6
2.0	8.4%	38.1%	3.4	3.4	10.9	95.7	8.0
2.5	7.7%	45.8%	4.2	4.2	13.6	95.0	7.3
3.0	5.9%	51.7%	5.1	5.1	16.3	94.2	5.6
3.5	4.4%	56.1%	5.9	5.9	19.0	93.4	4.1
4.0	4.7%	60.7%	6.8	6.8	21.7	92.6	4.3
4.5	3.3%	64.0%	7.6	7.6	24.5	91.8	3.0
5.0	3.0%	67.1%	8.5	8.5	27.2	91.1	2.8
6.0	5.4%	72.4%	10.2	10.2	32.6	89.5	4.8
7.0	4.4%	76.8%	11.8	11.8	38.0	88.0	3.8
8.0	3.5%	80.3%	13.5	13.5	43.5	86.4	3.1
9.0	2.8%	83.2%	15.2	15.2	48.9	84.8	2.4
10.0	2.2%	85.3%	16.9	16.9	54.3	83.3	1.8
15.0	7.0%	92.3%	25.4	25.4	81.5	75.5	5.3
20.0	4.5%	96.9%	33.9	31.2	100.0	64.6	2.9
25.0	1.4%	98.3%	42.3	31.2	100.0	51.7	0.7
30.0	0.7%	99.0%	50.8	31.2	100.0	43.1	0.3
35.0	0.5%	99.5%	59.2	31.2	100.0	36.9	0.2
40.0	0.5%	100.0%	67.7	31.2	100.0	32.3	0.2
45.0	0.0%	100.0%	76.2	31.2	100.0	28.7	0.0
50.0	0.0%	100.0%	84.6	31.2	100.0	25.8	0.0

89.5

Removal Efficiency Adjustment<sup>2</sup> = 6.5%  
**Predicted Net Annual Load Removal Efficiency = 83.0%**  
**Predicted % Annual Rainfall Treated = 98.5%**

1 - Based on 42 years of hourly rainfall data from Canadian Station 6105976, Ottawa ON  
 2 - Reduction due to use of 60-minute data for a site that has a time of concentration less than 30-minutes.  
 3 - CDS Efficiency based on testing conducted at the University of Central Florida  
 4 - CDS design flowrate and scaling based on standard manufacturer model & product specifications

## CDS PMSU2020-5-C DESIGN NOTES

THE STANDARD CDS PMSU2020-5-C CONFIGURATION IS SHOWN. ALTERNATE CONFIGURATIONS ARE AVAILABLE AND ARE LISTED BELOW. SOME CONFIGURATIONS MAY BE COMBINED TO SUIT SITE REQUIREMENTS.

### CONFIGURATION DESCRIPTION

GRATED INLET ONLY (NO INLET PIPE)
GRATED INLET WITH INLET PIPE OR PIPES
CURB INLET ONLY (NO INLET PIPE)
CURB INLET WITH INLET PIPE OR PIPES
CUSTOMIZABLE SUMP DEPTH AVAILABLE
ANTI-FLOTATION DESIGN AVAILABLE UPON REQUEST

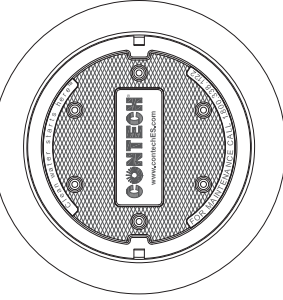

### SITE SPECIFIC DATA REQUIREMENTS

STRUCTURE ID	
WATER QUALITY FLOW RATE (CFS OR US)	*
PEAK FLOW RATE (CFS OR US)	*
RETURN PERIOD OF PEAK FLOW (YRS)	*
SCREEN APERTURE (2400 OR 4700)	*
PIPE DATA: I.E. MATERIAL	DIAMETER
INLET PIPE 1	*
INLET PIPE 2	*
OUTLET PIPE	*
RIM ELEVATION	*
ANTI-FLOTATION BALLAST	WIDTH
	HEIGHT
NOTES/SPECIAL REQUIREMENTS:	
* PER ENGINEER OF RECORD	

**FRAME AND COVER**  
(DIAMETER VARIES)  
N.T.S.

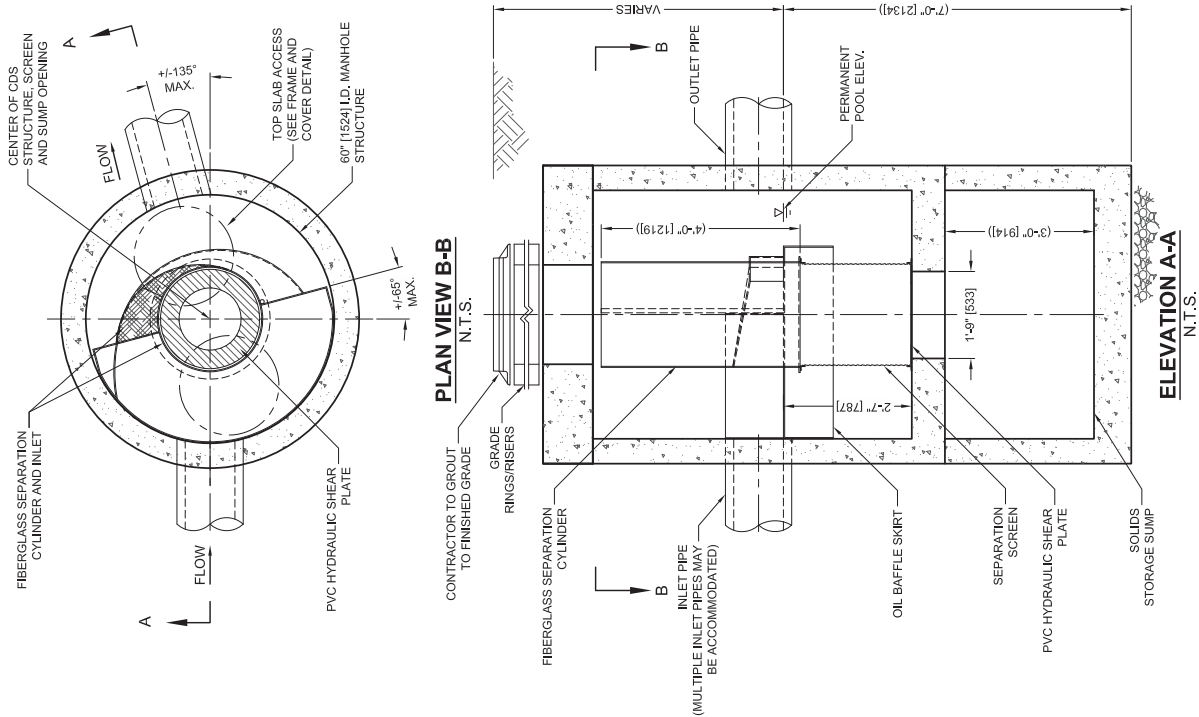

- GENERAL NOTES**
- CONTECH TO PROVIDE ALL MATERIALS UNLESS NOTED OTHERWISE.
  - CONTECH TO PROVIDE ALL FABRICATION DRAWINGS WITH DETAILED STRUCTURE DIMENSIONS AND WEIGHTS. PLEASE CONTACT YOUR CONTECH ENGINEER FOR FABRICATION DRAWINGS WITH DETAILED STRUCTURE DIMENSIONS AND WEIGHTS. [www.conteches.com](http://www.conteches.com)
  - SOLUTIONS LLC REPRESENTATIVE.
  - CDS WATER QUALITY STRUCTURE SHALL BE IN ACCORDANCE WITH ALL DESIGN DATA AND INFORMATION CONTAINED IN THIS DRAWING. CONTRACTOR TO PROVIDE AASHTO M 240 AND CASTINGS SHALL MEET M 240 (AASHTO M 306) LOAD RATING, ASSUMING GROUNDWATER ELEVATION AT, OR BELOW, THE OUTLET PIPE INVERT ELEVATION. ENGINEER OF RECORD TO CONFIRM ACTUAL GROUNDWATER ELEVATION.
  - PVC HYDRAULIC SHEAR PLATE IS PLACED ON SHELF AT BOTTOM OF SCREEN CYLINDER. REMOVE AND REPLACE AS NECESSARY DURING MAINTENANCE CLEANING.
- INSTALLATION NOTES**
- ANY SUB-BASE, BACKFILL DEPTH, AND/OR ANTI-FLOTATION PROVISIONS ARE SITE-SPECIFIC DESIGN CONSIDERATIONS AND SHALL BE SPECIFIED BY ENGINEER OF RECORD.
  - ANY SPECIAL EQUIPMENT WITH SUFFICIENT LIFTING AND REACH CAPACITY TO LIFT AND SET THE CDS MANHOLE STRUCTURE MUST BE PROVIDED.
  - CONTRACTOR TO ADD JOINT SEALANT BETWEEN ALL STRUCTURE SECTIONS, AND ASSEMBLY STRUCTURE.
  - CONTRACTOR TO PROVIDE, INSTALL, AND GROUT PIPES. MATCH PIPE INVERTS WITH ELEVATIONS SHOWN.
  - CONTRACTOR TO TAKE APPROPRIATE MEASURES TO ASSURE UNIT IS WATER TIGHT, HOLDING WATER TO FLOWLINE INVERT MINIMUM. IT IS SUGGESTED THAT ALL JOINTS BELOW PIPE INVERTS ARE GROUTED.

9025 Centre Pointe Dr., Suite 400, West Chester, OH 45069  
www.conteches.com  
800-338-1122 513-845-7000 513-845-7883 FAX

CDS PMSU2020-5-C  
INLINE CDS  
STANDARD DETAIL

## STORMWATER MANAGEMENT CALCULATIONS

The orifice calculations are based on the following formula:

$$Q = C_d \times A_o \sqrt{2gh} \times 1000$$

where:

Q = flowrate in litres per second

$C_d$  = coefficient of discharge

$A_o$  = orifice area in sq.m.

g = 9.81 m/s<sup>2</sup>

h = head above orifice in meters

Storage calculations in the paved areas above catch basins are based on the following formula for volume of a cone (or pyramid):

$$V = (A \times d)/3$$

where:

V = volume in cu.m.

A = ponding area in sq.m.

d = ponding depth in meters

## Area Draining to Alta Vista Drive Summary Tables

ONE-HUNDRED-YEAR EVENT					
Drainage Area	Pre-Development Flow Rate (L/s)	Maximum Allowable Release Rate (L/s)	Maximum Release Rate (L/s)	Maximum Volume Required (cu.m)	Maximum Volume Stored (cu.m)
AREA I (Uncontrolled Flow Off Site)	-	-	3.28	-	-
AREA II	-	-	6.00	28.37	28.37
TOTAL	23.90	8.90	9.28	28.37	28.37

FIVE-YEAR EVENT					
Drainage Area	Pre-Development Flow Rate (L/s)	Maximum Allowable Release Rate (L/s)	Maximum Release Rate (L/s)	Maximum Volume Required (cu.m)	Maximum Volume Stored (cu.m)
AREA I (Uncontrolled Flow Off Site)	-	-	1.72	-	-
AREA II	-	-	5.94	10.75	10.75
TOTAL	12.08	8.90	7.66	10.75	10.75

2262 Braeside Avenue  
 & Site Improvements  
 2262-2270 Braeside Avenue & 2345 Alta Vista Drive

Ottawa, Ontario

# Area Draining to Alta Vista Drive Drainage Areas I & II

## STORM WATER MANAGEMENT CALCULATIONS Rational Method / Modified Rational Method

### 100-YEAR PRE-DEVELOPMENT FLOW RATE

			C
Roof Area:	68	sq.m	1.00
Hard Area:	250	sq.m	1.00
Soft Area:	<u>654</u>	<u>sq.m</u>	<u>0.25</u>
Total Catchment Area:	972	sq.m	0.50
Total Catchment Area (A):	972	sq.m	
Time of Concentration:	10	min	
Rainfall Intensity (i):	179	mm/hr (100-Year Event)	
Runoff Coefficient (C):	0.50		
100-Year Pre-Development Flow Rate (2.78AiC):	23.90	L/s	

### 5-YEAR PRE-DEVELOPMENT FLOW RATE

			C
Roof Area:	68	sq.m	0.90
Hard Area:	250	sq.m	0.90
Soft Area:	<u>654</u>	<u>sq.m</u>	<u>0.20</u>
Total Catchment Area:	972	sq.m	0.43
Total Catchment Area (A):	972	sq.m	
Time of Concentration:	10	min	
Rainfall Intensity (i):	104	mm/hr (5-Year Event)	
Runoff Coefficient (C):	0.43		
5-Year Pre-Development Flow Rate (2.78AiC):	12.08	L/s	

### MAXIMUM ALLOWABLE RELEASE RATE

			C
Roof Area:	68	sq.m	0.90
Hard Area:	250	sq.m	0.90
Soft Area:	<u>654</u>	<u>sq.m</u>	<u>0.20</u>
Total Catchment Area:	972	sq.m	0.43
Total Catchment Area (A):	972	sq.m	
Time of Concentration:	10	min	
Rainfall Intensity (i):	77	mm/hr (2-Year Event)	
Runoff Coefficient (C):	0.43		
Maximum Allowable Release Rate (2.78AiC):	8.90	L/s	

# ONE-HUNDRED-YEAR EVENT

## DRAINAGE AREA I (Uncontrolled Flow Off Site)

(ONE-HUNDRED-YEAR EVENT)

			C
Roof Area:	0	sq.m	1.00
Asphalt/Concrete Area:	66	sq.m	1.00
Landscaped Area:	<u>0</u>	<u>sq.m</u>	<u>0.25</u>
Total Catchment Area:	66	sq.m	1.00
Area (A):	66	sq.m	
Time of Concentration:	10	min	
Rainfall Intensity (i):	179	mm/hr	
Runoff Coefficient (C):	1.00		
Flow Rate (2.78AiC):	3.28	L/s	



## DRAINAGE AREA II

(ONE-HUNDRED-YEAR EVENT)

				C			
	Roof Area:	68	sq.m		1.00		
	Asphalt/Concrete Area:	763	sq.m		1.00		
	Landscaped Area:	75	sq.m		0.25		
	<hr/>				<hr/>		
	Total Catchment Area:	906	sq.m		0.94		
	Water Elevation:	102.55	m				
	Invert of Outlet Pipe - CB/MH-3:	100.22	m				
	Centroid of ICD Orifice:	100.26	m				
	(ICD in Outlet Pipe of CB/MH-3)						
	Head:	2.29	m				
					Surface Storage Above Catch-Basin		
	Orifice Diameter:	75	mm	CB	Top Area	Depth	Volume
					(sq.m)	(m)	(V = A X D / 3)
	Orifice Area:	4418	sq.mm	CB-1	197	0.16	10.48
				CB/MH-2	146	0.15	7.25
	Coefficient of Discharge:	0.203		CB/MH-3	200	0.16	10.64
							cu.m
	Maximum Release Rate:	6.00	L/s		Achieved Volume:	28.37	cu.m
					Maximum Volume Required:	28.37	cu.m
					Release	Stored	Stored
	Time	i	2.78AiC	Rate	Rate	Volume	
	(min)	(mm/hr)	(L/s)	(L/s)	(L/s)	(cu.m)	
	5	243	57.33	6.00	51.34	15.40	
	10	179	42.18	6.00	36.18	21.71	
	15	143	33.76	6.00	27.76	24.98	
	20	120	28.34	6.00	22.34	26.80	
	25	104	24.53	6.00	18.53	27.80	
	30	92	21.70	6.00	15.70	28.27	
	35	83	19.51	6.00	13.51	28.37	
	40	75	17.75	6.00	11.75	28.21	
	45	69	16.31	6.00	10.31	27.84	
	50	64	15.11	6.00	9.11	27.33	
	55	60	14.08	6.00	8.09	26.68	
	60	56	13.20	6.00	7.21	25.94	
	65	53	12.44	6.00	6.44	25.11	
	70	50	11.76	6.00	5.76	24.20	
	75	47	11.16	6.00	5.16	23.24	
	80	45	10.63	6.00	4.63	22.22	
	85	43	10.15	6.00	4.15	21.16	
	90	41	9.71	6.00	3.71	20.05	
	95	39	9.32	6.00	3.32	18.91	
	100	38	8.95	6.00	2.95	17.73	
	105	36	8.62	6.00	2.62	16.52	
	110	35	8.32	6.00	2.32	15.29	
	115	34	8.03	6.00	2.03	14.04	
	120	33	7.77	6.00	1.77	12.76	
	125	32	7.53	6.00	1.53	11.46	
	130	31	7.30	6.00	1.30	10.14	
	135	30	7.09	6.00	1.09	8.81	
	140	29	6.89	6.00	0.89	7.46	
	145	28	6.70	6.00	0.70	6.09	
	150	28	6.52	6.00	0.52	4.71	
	180	24	5.65	5.65	0.00	0.00	
	210	21	4.99	4.99	0.00	0.00	
	240	19	4.49	4.49	0.00	0.00	
	270	17	4.09	4.09	0.00	0.00	
	300	16	3.75	3.75	0.00	0.00	

# FIVE-YEAR EVENT

## DRAINAGE AREA I (Uncontrolled Flow Off Site)

(FIVE-YEAR EVENT)

			C
Roof Area:	0	sq.m	0.90
Asphalt/Concrete Area:	66	sq.m	0.90
Landscaped Area:	<u>0</u>	<u>sq.m</u>	<u>0.20</u>
Total Catchment Area:	66	sq.m	0.90
Area (A):	66	sq.m	
Time of Concentration:	10	min	
Rainfall Intensity (i):	104	mm/hr	
Runoff Coefficient (C):	0.90		
Flow Rate (2.78AiC):	1.72	L/s	

# DRAINAGE AREA II

(FIVE-YEAR EVENT)

			C
Roof Area:	68	sq.m	0.90
Asphalt/Concrete Area:	763	sq.m	0.90
Landscaped Area:	75	sq.m	0.20

Total Catchment Area: 906 sq.m 0.84

Water Elevation: 102.51 m

Invert of Outlet Pipe - CB/MH-3: 100.22 m

Centroid of ICD Orifice: 100.26 m

(ICD in Outlet Pipe of CB/MH-3)

Head: 2.25 m

### Surface Storage Above Catch-Basin

Orifice Diameter:	75	mm	CB	Top Area (sq.m)	Depth (m)	Volume (V = A X D / 3)
Orifice Area:	4418	sq.mm	CB-1	105	0.12	4.05 cu.m
			CB/MH-2	73	0.11	2.60 cu.m
Coefficient of Discharge:	0.203		CB/MH-3	106	0.12	4.11 cu.m

Maximum Release Rate: 5.94 L/s Achieved Volume: 10.75 cu.m

Maximum Volume Required: 10.75 cu.m

Time (min)	i (mm/hr)	2.78AiC (L/s)	Release Rate (L/s)	Stored Rate (L/s)	Stored Volume (cu.m)
5	141	29.94	5.94	24.00	7.20
10	104	22.10	5.94	16.16	9.69
15	84	17.72	5.94	11.78	10.60
20	70	14.90	5.94	8.96	10.75
25	61	12.92	5.94	6.97	10.46
30	54	11.44	5.94	5.50	9.89
35	49	10.29	5.94	4.35	9.13
40	44	9.37	5.94	3.43	8.23
45	41	8.62	5.94	2.67	7.22
50	38	7.99	5.94	2.04	6.13
55	35	7.45	5.94	1.51	4.97
60	33	6.99	5.94	1.04	3.76
65	31	6.58	5.94	0.64	2.50
70	29	6.23	5.94	0.29	1.21
75	28	5.91	5.91	0.00	0.00
80	27	5.63	5.63	0.00	0.00
85	25	5.38	5.38	0.00	0.00
90	24	5.15	5.15	0.00	0.00
95	23	4.94	4.94	0.00	0.00
100	22	4.75	4.75	0.00	0.00
105	22	4.58	4.58	0.00	0.00
110	21	4.42	4.42	0.00	0.00
115	20	4.27	4.27	0.00	0.00
120	19	4.13	4.13	0.00	0.00
125	19	4.00	4.00	0.00	0.00
130	18	3.88	3.88	0.00	0.00
135	18	3.77	3.77	0.00	0.00
140	17	3.66	3.66	0.00	0.00
145	17	3.56	3.56	0.00	0.00
150	16	3.47	3.47	0.00	0.00
180	14	3.01	3.01	0.00	0.00
210	13	2.66	2.66	0.00	0.00
240	11	2.40	2.40	0.00	0.00
270	10	2.18	2.18	0.00	0.00
300	9	2.01	2.01	0.00	0.00

## Area Draining to Braeside Avenue Summary Tables

ONE HUNDRED YEAR EVENT					
Drainage Area	Pre-Development Flow Rate (L/s)	Maximum Allowable Release Rate (L/s)	Maximum Release Rate (L/s)	Maximum Volume Required (cu.m)	Maximum Volume Stored (cu.m)
AREA III (Uncontrolled Flow Off Site)	-	-	8.08	-	-
AREA IV	-	-	6.00	33.29	33.29
AREA V	-	-	6.00	22.43	22.43
TOTAL	51.20	19.10	20.08	55.72	55.72

FIVE YEAR EVENT					
Drainage Area	Pre-Development Flow Rate (L/s)	Maximum Allowable Release Rate (L/s)	Maximum Release Rate (L/s)	Maximum Volume Required (cu.m)	Maximum Volume Stored (cu.m)
AREA III (Uncontrolled Flow Off Site)	-	-	4.09	-	-
AREA IV	-	-	4.73	15.00	15.00
AREA V	-	-	4.52	10.17	10.17
TOTAL	25.91	19.10	13.35	25.17	25.17

2262 Braeside Avenue  
 & Site Improvements  
 2262-2270 Braeside Avenue & 2345 Alta Vista Drive

Ottawa, Ontario

# Area Draining to Braeside Avenue Drainage Areas III, IV & V

## STORM WATER MANAGEMENT CALCULATIONS Rational Method / Modified Rational Method

### 100-YEAR PRE-DEVELOPMENT FLOW RATE

			C
Roof Area:	169	sq.m	1.00
Hard Area:	525	sq.m	1.00
Soft Area:	<u>1,350</u>	<u>sq.m</u>	<u>0.25</u>
Total Catchment Area:	2,044	sq.m	0.50
Total Catchment Area (A):	2,044	sq.m	
Time of Concentration:	10	min	
Rainfall Intensity (i):	179	mm/hr	
Runoff Coefficient (C):	0.50		
100-Year Pre-Development Flow Rate (2.78AiC):	51.20	L/s	

### 5-YEAR PRE-DEVELOPMENT FLOW RATE

			C
Roof Area:	169	sq.m	0.90
Hard Area:	525	sq.m	0.90
Soft Area:	<u>1,350</u>	<u>sq.m</u>	<u>0.20</u>
Total Catchment Area:	2,044	sq.m	0.44
Total Catchment Area (A):	2,044	sq.m	
Time of Concentration:	10	min	
Rainfall Intensity (i):	104	mm/hr	
Runoff Coefficient (C):	0.44		
5-Year Pre-Development Flow Rate (2.78AiC):	25.91	L/s	

### MAXIMUM ALLOWABLE RELEASE RATE

			C
Roof Area:	169	sq.m	0.90
Hard Area:	525	sq.m	0.90
Soft Area:	<u>1,350</u>	<u>sq.m</u>	<u>0.20</u>
Total Catchment Area:	2,044	sq.m	0.44
Total Catchment Area (A):	2,044	sq.m	
Time of Concentration:	10	min	
Rainfall Intensity (i):	77	mm/hr (2-Year Event)	
Runoff Coefficient (C):	0.44		
Maximum Allowable Release Rate (2.78AiC):	19.10	L/s	

# ONE-HUNDRED-YEAR EVENT

## DRAINAGE AREA III (Uncontrolled Flow Off Site)

(ONE-HUNDRED-YEAR EVENT)

			C
Roof Area:	55	sq.m	1.00
Asphalt/Concrete Area:	56	sq.m	1.00
Landscaped Area:	<u>207</u>	<u>sq.m</u>	<u>0.25</u>
Total Catchment Area:	318	sq.m	0.51
Area (A):	318	sq.m	
Time of Concentration:	10	min	
Rainfall Intensity (i):	179	mm/hr	
Runoff Coefficient (C):	0.51		
Flow Rate (2.78AiC):	8.08	L/s	

## DRAINAGE AREA IV

(ONE-HUNDRED-YEAR EVENT)

			C		
	Roof Area:	530	sq.m		1.00
	Asphalt/Concrete Area:	178	sq.m		1.00
	Landscaped Area:	321	sq.m		0.25
	Total Catchment Area:	1029	sq.m		0.77
Water Elevation: 99.21 m					
Invert of Outlet Pipe - CB/MH-16: 97.44 m					
Centroid of ICD Orifice: 97.57 m					
(ICD in Outlet Pipe of CB/MH-16)					
Head: 1.65 m					
Orifice Diameter: 75 mm					
Orifice Area: 4418 sq.mm					
Coefficient of Discharge: 0.239					
Maximum Release Rate: 6.00 L/s					
			Underground Storage (See details on next page)		
			Chamber	Clear Stone	Volume
			Storage	Storage	(cu.m)
			(cu.m)	(cu.m)	<u>33.29</u> cu.m
			13.26	20.03	
			Achieved Volume:		33.29 cu.m
			Maximum Volume Required:		33.29 cu.m
50% of Max.					
			Release	Stored	Stored
Time	i	2.78AiC	Rate	Rate	Volume
(min)	(mm/hr)	(L/s)	(L/s)	(L/s)	(cu.m)
5	243	53.18	3.00	50.18	15.05
10	179	39.13	3.00	36.13	21.68
15	143	31.31	3.00	28.31	25.48
20	120	26.29	3.00	23.28	27.94
25	104	22.76	3.00	19.76	29.63
30	92	20.13	3.00	17.13	30.83
35	83	18.10	3.00	15.09	31.70
40	75	16.47	3.00	13.47	32.32
45	69	15.13	3.00	12.13	32.75
50	64	14.01	3.00	11.01	33.04
55	60	13.07	3.00	10.06	33.21
60	56	12.25	3.00	9.25	33.29
65	53	11.54	3.00	8.54	33.29
70	50	10.91	3.00	7.91	33.22
75	47	10.36	3.00	7.35	33.09
80	45	9.86	3.00	6.86	32.92
85	43	9.41	3.00	6.41	32.70
90	41	9.01	3.00	6.01	32.44
95	39	8.64	3.00	5.64	32.15
100	38	8.31	3.00	5.30	31.83
105	36	8.00	3.00	5.00	31.48
110	35	7.71	3.00	4.71	31.10
115	34	7.45	3.00	4.45	30.71
120	33	7.21	3.00	4.21	30.29
125	32	6.98	3.00	3.98	29.85
130	31	6.77	3.00	3.77	29.40
135	30	6.57	3.00	3.57	28.93
140	29	6.39	3.00	3.39	28.45
145	28	6.21	3.00	3.21	27.95
150	28	6.05	3.00	3.05	27.44
180	24	5.24	3.00	2.24	24.15
210	21	4.63	3.00	1.63	20.56
240	19	4.16	3.00	1.16	16.75
270	17	3.79	3.00	0.79	12.77
300	16	3.48	3.00	0.48	8.66

DRAINAGE AREA IV - continued  
(ONE-HUNDRED-YEAR EVENT)

Soleno Hydrostor HS75 Chambers

# Chambers	Installed Length of each (m)	Height (m)	Width (m)	Volume Per Chamber (cu.m)	# End Caps	Installed Length of each (m)	Volume Per End Cap (cu.m)	Chamber & End Cap Length (m)	Chamber & End Cap Volume (cu.m)
10	2.157	0.754	1.295	1.31	2	0.203	0.08	21.98	13.26

Clear Stone

Dimension Above Chamber (m)	Dimension From Side of Chamber (m)	Dimension From End of Chamber (m)	Length (m)	Width (m)	Depth (m)	Clear Stone Storage Volume (cu.m)	Clear Stone Volume (cu.m)	Clear Stone 40% Voids (cu.m)	Total Volume (cu.m)
0.20	0.75	0.30	22.58	2.80	1.00	50.07		20.03	
			Chamber Volume (cu.m)				Clear Stone Volume (cu.m)		Total Volume (cu.m)
			13.26	+			20.03	=	33.29



## DRAINAGE AREA Va

(excludes area that does not need to be controlled)

(ONE-HUNDRED-YEAR EVENT)

				C			
Roof Area:	69	sq.m		1.00			
Asphalt/Concrete Area:	484	sq.m		1.00			
Landscaped Area:	<u>144</u>	<u>sq.m</u>		<u>0.25</u>			
Total Catchment Area:	697	sq.m		0.85			
Water Elevation:	100.66	m					
					Surface Storage Above Catch-Basin		
Invert of Outlet Pipe - CB/MH-7:	97.85	m	CB	Top Area	Depth	Volume	
				(sq.m)	(m)	(V = A X D / 3)	
Centroid of ICD Orifice: (ICD in Outlet Pipe of CB/MH-7)	97.89	m	CB/MH-7	135	0.13	5.76	cu.m
Head:	2.77	m					
					Underground Storage (See details on next page)		
Orifice Diameter:	75	mm			Chamber	Clear Stone	
					Storage	Storage	Volume
Orifice Area:	4418	sq.mm			(cu.m)	(cu.m)	(cu.m)
Coefficient of Discharge:	0.184				10.52	6.14	<u>16.66</u>
Maximum Release Rate:	6.00	L/s			Achieved Volume:	22.43	cu.m
					Maximum Volume Required:	22.43	cu.m
					50% of Max.		
					Release	Stored	Stored
Time	i	2.78AiC		Rate	Rate	Volume	
(min)	(mm/hr)	(L/s)		(L/s)	(L/s)	(cu.m)	
5	243	39.74		3.00	36.74	11.02	
10	179	29.24		3.00	26.24	15.74	
15	143	23.40		3.00	20.40	18.36	
20	120	19.64		3.00	16.64	19.97	
25	104	17.00		3.00	14.00	21.01	
30	92	15.04		3.00	12.04	21.68	
35	83	13.52		3.00	10.52	22.10	
40	75	12.30		3.00	9.30	22.33	
45	69	11.31		3.00	8.31	22.43	
50	64	10.47		3.00	7.47	22.42	
55	60	9.76		3.00	6.76	22.32	
60	56	9.15		3.00	6.15	22.15	
65	53	8.62		3.00	5.62	21.92	
70	50	8.15		3.00	5.15	21.64	
75	47	7.74		3.00	4.74	21.32	
80	45	7.37		3.00	4.37	20.96	
85	43	7.03		3.00	4.03	20.57	
90	41	6.73		3.00	3.73	20.15	
95	39	6.46		3.00	3.46	19.71	
100	38	6.21		3.00	3.21	19.24	
105	36	5.98		3.00	2.98	18.75	
110	35	5.76		3.00	2.76	18.24	
115	34	5.57		3.00	2.57	17.72	
120	33	5.39		3.00	2.39	17.18	
125	32	5.22		3.00	2.22	16.63	
130	31	5.06		3.00	2.06	16.06	
135	30	4.91		3.00	1.91	15.48	
140	29	4.77		3.00	1.77	14.90	
145	28	4.64		3.00	1.64	14.30	
150	28	4.52		3.00	1.52	13.69	
180	24	3.91		3.00	0.91	9.87	
210	21	3.46		3.00	0.46	5.82	
240	19	3.11		3.00	0.11	1.61	
270	17	2.83		2.83	0.00	0.00	
300	16	2.60		2.60	0.00	0.00	

DRAINAGE AREA V - continued  
(ONE-HUNDRED-YEAR EVENT)

Soleno Hydrostor HS180 Chambers

# Chambers	Installed Length (m)	Height (m)	Width (m)	Volume Per Chamber (cu.m)	# End Caps	Length (m)	Volume Per End Cap (cu.m)	Chamber & End Cap Length (m)	Chamber & End Cap Volume (cu.m)
3	2.167	1.156	1.976	3.22	2	0.609	0.43	7.72	10.52

Clear Stone

Dimension Above Chamber (m)	Dimension From Side of Chamber (m)	Dimension From End of Chamber (m)	Clear Stone Length (m)	Width (m)	Clear Stone Storage Depth (m)	Clear Stone Volume (cu.m)	Clear Stone 40% Voids (cu.m)
0.15	0.225	0.225	8.17	2.43	1.31	15.36	6.14
			Chamber Volume (cu.m)	+	Clear Stone Volume (cu.m)	=	Total Volume (cu.m)
			10.52		6.14		16.66

# DRAINAGE AREA Va +Vb

(includes area that does not need to be controlled)

(ONE-HUNDRED-YEAR EVENT)

								C
	Roof Area:	265	sq.m					1.00
	Asphalt/Concrete Area:	597	sq.m					1.00
	Landscaped Area:	212	sq.m					0.25
Total Catchment Area:		1074	sq.m					0.85
	Water Elevation:	100.66	m					
				Surface Storage Above Catch-Basin				
Invert of Outlet Pipe - CB/MH-7:	97.85	m		CB	Top Area	Depth	Volume	
					(sq.m)	(m)	(V = A X D / 3)	
Centroid of ICD Orifice:	97.89	m		CB/MH-7	138	0.13	5.98	cu.m
(ICD in Outlet Pipe of CB/MH-7)								
Head:	2.77	m						
Underground Storage								
(See details on next page)								
Orifice Diameter:	75	mm			Chamber	Clear Stone		
					Storage	Storage	Volume	
Orifice Area:	4418	sq.mm			(cu.m)	(cu.m)		
Coefficient of Discharge:	0.184				10.52	6.14	16.66	cu.m
Maximum Release Rate:	6.00	L/s			Achieved Volume:	22.64	cu.m	
Maximum Overflow Rate:	8.64	L/s						
Total Maximum Release Rate:	14.64	L/s			Maximum Volume Required:	22.64	cu.m	
50%								
Max. ICD								
Time	i	2.78AiC	50%	Max. ICD	Release	Overflow	Stored	Stored
(min)	(mm/hr)	(L/s)	Rate	Rate	Rate	Rate	Volume	
5	243	61.74	3.00	0.00	58.74	17.62		
10	179	45.42	3.00	4.68	37.74	22.64		
15	143	36.35	3.00	8.19	25.16	22.64		
20	120	30.51	3.00	8.64	18.87	22.64		
25	104	26.42	3.00	8.32	15.10	22.64		
30	92	23.37	3.00	7.79	12.58	22.64		
35	83	21.01	3.00	7.22	10.78	22.64		
40	75	19.11	3.00	6.68	9.44	22.64		
45	69	17.56	3.00	6.18	8.39	22.64		
50	64	16.27	3.00	5.72	7.55	22.64		
55	60	15.17	3.00	5.30	6.86	22.64		
60	56	14.22	3.00	4.93	6.29	22.64		
65	53	13.39	3.00	4.58	5.81	22.64		
70	50	12.66	3.00	4.27	5.39	22.64		
75	47	12.02	3.00	3.99	5.03	22.64		
80	45	11.44	3.00	3.73	4.72	22.64		
85	43	10.93	3.00	3.49	4.44	22.64		
90	41	10.46	3.00	3.26	4.19	22.64		
95	39	10.03	3.00	3.06	3.97	22.64		
100	38	9.64	3.00	2.87	3.77	22.64		
105	36	9.28	3.00	2.69	3.59	22.64		
110	35	8.95	3.00	2.52	3.43	22.64		
115	34	8.65	3.00	2.37	3.28	22.64		
120	33	8.37	3.00	2.22	3.15	22.64		
125	32	8.10	3.00	2.08	3.02	22.64		
130	31	7.86	3.00	1.96	2.90	22.64		
135	30	7.63	3.00	1.83	2.80	22.64		
140	29	7.42	3.00	1.72	2.70	22.64		
145	28	7.21	3.00	1.61	2.60	22.64		
150	28	7.02	3.00	1.51	2.52	22.64		
180	24	6.08	3.00	0.98	2.10	22.64		
210	21	5.38	3.00	0.58	1.80	22.64		
240	19	4.83	3.00	0.26	1.57	22.64		
270	17	4.40	3.00	0.00	1.40	22.64		
300	16	4.04	3.00	0.00	1.04	18.74		

DRAINAGE AREA Va +Vb - continued  
(ONE-HUNDRED-YEAR EVENT)

Soleno Hydrostor HS180 Chambers

# Chambers	Installed Length (m)	Height (m)	Width (m)	Volume Per Chamber (cu.m)	# End Caps	Length (m)	Volume Per End Cap (cu.m)	Chamber & End Cap Length (m)	Chamber & End Cap Volume (cu.m)
3	2.167	1.156	1.976	3.22	2	0.609	0.43	7.72	10.52

Clear Stone

Dimension Above Chamber (m)	Dimension From Side of Chamber (m)	Dimension From End of Chamber (m)	Clear Stone Length (m)	Width (m)	Clear Stone Storage Depth (m)	Clear Stone Volume (cu.m)	Clear Stone 40% Voids (cu.m)
0.15	0.225	0.225	8.17	2.43	1.31	15.36	6.14
			Chamber Volume (cu.m)	+	Clear Stone Volume (cu.m)	=	Total Volume (cu.m)
			10.52		6.14		16.66

# FIVE YEAR EVENT

## DRAINAGE AREA III (Uncontrolled Flow Off Site)

(FIVE-YEAR EVENT)

			C
Roof Area:	55	sq.m	0.90
Asphalt/Concrete Area:	56	sq.m	0.90
Landscaped Area:	<u>207</u>	<u>sq.m</u>	<u>0.20</u>
Total Catchment Area:	318	sq.m	0.44
Area (A):	318	sq.m	
Time of Concentration:	10	min	
Rainfall Intensity (i):	104	mm/hr	
Runoff Coefficient (C):	0.44		
Flow Rate (2.78AiC):	4.09	L/s	

# DRAINAGE AREA IV

(FIVE-YEAR EVENT)

			C
Roof Area:	530	sq.m	0.90
Asphalt/Concrete Area:	178	sq.m	0.90
Landscaped Area:	321	sq.m	0.20

Total Catchment Area: 1029 sq.m 0.68

Water Elevation:	98.59	m
Invert of Outlet Pipe - CB/MH-18:	97.44	m
Centroid of ICD Orifice:	97.57	m
(ICD in Outlet Pipe of CB/MH-18)		
Head:	1.03	m

Orifice Diameter:	75	mm	Underground Storage (See details on next page)		
Orifice Area:	4418	sq.mm	Chamber Storage (cu.m)	Clear Stone Storage (cu.m)	Volume cu.m
Coefficient of Discharge:	0.239		8.35	6.65	15.00
Maximum Release Rate:	4.73	L/s	Achieved Volume: 15.00 cu.m		

Maximum Volume Required: 15.00 cu.m

Time (min)	i (mm/hr)	2.78AiC (L/s)	50% of Max.		
			Release Rate (L/s)	Stored Rate (L/s)	Stored Volume (cu.m)
5	141	27.53	2.37	25.16	7.55
10	104	20.32	2.37	17.95	10.77
15	84	16.29	2.37	13.93	12.53
20	70	13.70	2.37	11.33	13.60
25	61	11.87	2.37	9.51	14.26
30	54	10.52	2.37	8.15	14.67
35	49	9.46	2.37	7.09	14.90
40	44	8.62	2.37	6.25	15.00
45	41	7.92	2.37	5.55	15.00
50	38	7.34	2.37	4.97	14.92
55	35	6.85	2.37	4.48	14.79
60	33	6.42	2.37	4.06	14.60
65	31	6.05	2.37	3.69	14.38
70	29	5.73	2.37	3.36	14.11
75	28	5.44	2.37	3.07	13.82
80	27	5.18	2.37	2.81	13.50
85	25	4.95	2.37	2.58	13.15
90	24	4.74	2.37	2.37	12.79
95	23	4.54	2.37	2.18	12.41
100	22	4.37	2.37	2.00	12.01
105	22	4.21	2.37	1.84	11.60
110	21	4.06	2.37	1.69	11.17
115	20	3.92	2.37	1.56	10.74
120	19	3.80	2.37	1.43	10.29
125	19	3.68	2.37	1.31	9.83
130	18	3.57	2.37	1.20	9.36
135	18	3.46	2.37	1.10	8.88
140	17	3.37	2.37	1.00	8.40
145	17	3.28	2.37	0.91	7.91
150	16	3.19	2.37	0.82	7.41
180	14	2.76	2.37	0.40	4.30
210	13	2.45	2.37	0.08	1.02
240	11	2.20	2.20	0.00	0.00
270	10	2.01	2.01	0.00	0.00
300	9	1.84	1.84	0.00	0.00

DRAINAGE AREA IV - continued  
(FIVE-YEAR EVENT)

Soleno Hydrostor HS75 Chambers

# Chambers	Installed Length of each (m)	Height (m)	Width (m)	Volume Per Chamber (cu.m)	# End Caps	Installed Length of each (m)	Volume Per End Cap (cu.m)	Chamber & End Cap Length (m)	Chamber & End Cap Volume (cu.m)
10	2.157	0.754	1.295	0.82	2	0.203	0.05	21.98	8.35

Clear Stone

Dimension Above Chamber (m)	Dimension From Side of Chamber (m)	Dimension From End of Chamber (m)	Length (m)	Width (m)	Depth (m)	Clear Stone Storage Volume (cu.m)	Clear Stone Volume (cu.m)	Clear Stone 40% Voids Volume (cu.m)	Total Volume (cu.m)
0.20	0.75	0.75	23.48	2.80	0.38	16.63	6.65		
			Chamber Volume (cu.m)						
			8.35	+		6.65	=		15.00

## DRAINAGE AREA Va

(excludes area that does not need to be controlled)

(FIVE-YEAR EVENT)

				C			
	Roof Area:	69	sq.m	0.90			
	Asphalt/Concrete Area:	484	sq.m	0.90			
	Landscaped Area:	144	sq.m	0.20			
	Total Catchment Area:	697	sq.m	0.76			
	Water Elevation:	99.46	m				
	Invert of Outlet Pipe - CB/MH-7:	97.85	m	CB	Surface Storage Above Catch-Basin		
	Centroid of ICD Orifice:	97.89	m	CB/MH-7	Top Area (sq.m)	Depth (m)	Volume (V = A X D / 3) cu.m
	(ICD in Outlet Pipe of CB/MH-7)				0	0.00	0.00
	Head:	1.57	m				
	Orifice Diameter:	75	mm		Underground Storage (See details on next page)		
	Orifice Area:	4418	sq.mm		Chamber Storage (cu.m)	Clear Stone Storage (cu.m)	Volume cu.m
	Coefficient of Discharge:	0.184			7.59	2.58	10.17
	Maximum Release Rate:	4.52	L/s		Achieved Volume:	10.17	cu.m
					Maximum Volume Required:	10.17	cu.m
				50% of Max.			
	Time (min)	i (mm/hr)	2.78AiC (L/s)	Release Rate (L/s)	Stored Rate (L/s)	Stored Volume (cu.m)	
	5	141	20.66	2.26	18.40	5.52	
	10	104	15.25	2.26	12.99	7.79	
	15	84	12.23	2.26	9.97	8.97	
	20	70	10.28	2.26	8.02	9.63	
	25	61	8.91	2.26	6.65	9.98	
	30	54	7.89	2.26	5.63	10.14	
	35	49	7.10	2.26	4.84	10.17	
	40	44	6.47	2.26	4.21	10.10	
	45	41	5.95	2.26	3.69	9.96	
	50	38	5.51	2.26	3.25	9.76	
	55	35	5.14	2.26	2.88	9.51	
	60	33	4.82	2.26	2.56	9.23	
	65	31	4.54	2.26	2.28	8.91	
	70	29	4.30	2.26	2.04	8.57	
	75	28	4.08	2.26	1.82	8.20	
	80	27	3.89	2.26	1.63	7.82	
	85	25	3.71	2.26	1.45	7.42	
	90	24	3.56	2.26	1.30	7.00	
	95	23	3.41	2.26	1.15	6.57	
	100	22	3.28	2.26	1.02	6.12	
	105	22	3.16	2.26	0.90	5.67	
	110	21	3.05	2.26	0.79	5.21	
	115	20	2.94	2.26	0.69	4.73	
	120	19	2.85	2.26	0.59	4.25	
	125	19	2.76	2.26	0.50	3.76	
	130	18	2.68	2.26	0.42	3.27	
	135	18	2.60	2.26	0.34	2.76	
	140	17	2.53	2.26	0.27	2.26	
	145	17	2.46	2.26	0.20	1.74	
	150	16	2.39	2.26	0.14	1.22	
	180	14	2.08	2.08	0.00	0.00	
	210	13	1.84	1.84	0.00	0.00	
	240	11	1.65	1.65	0.00	0.00	
	270	10	1.51	1.51	0.00	0.00	
	300	9	1.38	1.38	0.00	0.00	



DRAINAGE AREA Va - continued  
(FIVE-YEAR EVENT)

Soleno Hydrostor HS180 Chambers

# Chambers	Installed Length (m)	Height (m)	Width (m)	Volume Per Chamber (cu.m)	# End Caps	Length (m)	Volume Per End Cap (cu.m)	Chamber & End Cap Length (m)	Chamber & End Cap Volume (cu.m)
3	2.167	1.156	1.976	2.32	2	0.609	0.31	7.72	7.59

Clear Stone

Dimension Above Chamber (m)	Dimension From Side of Chamber (m)	Dimension From End of Chamber (m)	Clear Stone Length (m)	Available Width (m)	Clear Stone Storage Depth (m)	Clear Stone Volume (cu.m)	Clear Stone 40% Voids (cu.m)	Clear Stone Total Volume (cu.m)
0.15	0.225	0.225	8.17	2.43	0.71	6.45	2.58	
			Chamber Volume (cu.m)	+		Clear Stone Volume (cu.m)	=	Total Volume (cu.m)
			7.59			2.58		10.17

**DRAINAGE AREA Va +Vb**

(includes area that does not need to be controlled)

(FIVE-YEAR EVENT)

				C		
Roof Area:	265	sq.m		0.90		
Asphalt/Concrete Area:	597	sq.m		0.90		
Landscaped Area:	<u>212</u>	sq.m		<u>0.20</u>		
Total Catchment Area:	1074	sq.m		0.76		
Water Elevation:	100.58	m				
Invert of Outlet Pipe - CB/MH-7:	97.85	m	CB	Surface Storage Above Catch-Basin		
				Top Area	Depth	Volume
				(sq.m)	(m)	(V = A X D / 3)
Centroid of ICD Orifice:	97.89	m	CB/MH-7	21	0.05	0.36 cu.m
(ICD in Outlet Pipe of CB/MH-7)						
Head:	2.69	m				
Orifice Diameter:	75	mm		Underground Storage (See details on next page)		
				Chamber	Clear Stone	
Orifice Area:	4418	sq.mm		Storage	Storage	Volume
				(cu.m)	(cu.m)	
Coefficient of Discharge:	0.184			10.52	6.14	<u>16.66</u> cu.m
Maximum Release Rate:	5.92	L/s		Achieved Volume:	17.02	cu.m
				Maximum Volume Required:	17.02	cu.m

50% of Max.

Time (min)	i (mm/hr)	2.78AiC (L/s)	Release Rate (L/s)	Stored Rate (L/s)	Stored Volume (cu.m)
5	141	32.11	2.96	29.15	8.75
10	104	23.70	2.96	20.74	12.45
15	84	19.01	2.96	16.05	14.44
20	70	15.98	2.96	13.02	15.63
25	61	13.85	2.96	10.89	16.34
30	54	12.27	2.96	9.31	16.76
35	49	11.04	2.96	8.08	16.96
40	44	10.05	2.96	7.09	17.02
45	41	9.24	2.96	6.28	16.97
50	38	8.56	2.96	5.61	16.82
55	35	7.99	2.96	5.03	16.60
60	33	7.49	2.96	4.54	16.33
65	31	7.06	2.96	4.10	16.00
70	29	6.68	2.96	3.72	15.64
75	28	6.34	2.96	3.39	15.24
80	27	6.04	2.96	3.08	14.80
85	25	5.77	2.96	2.81	14.34
90	24	5.52	2.96	2.57	13.86
95	23	5.30	2.96	2.34	13.36
100	22	5.10	2.96	2.14	12.83
105	22	4.91	2.96	1.95	12.29
110	21	4.74	2.96	1.78	11.74
115	20	4.58	2.96	1.62	11.17
120	19	4.43	2.96	1.47	10.59
125	19	4.29	2.96	1.33	9.99
130	18	4.16	2.96	1.20	9.39
135	18	4.04	2.96	1.08	8.77
140	17	3.93	2.96	0.97	8.15
145	17	3.82	2.96	0.86	7.52
150	16	3.72	2.96	0.76	6.88
180	14	3.23	2.96	0.27	2.89
210	13	2.86	2.86	0.00	0.00
240	11	2.57	2.57	0.00	0.00
270	10	2.34	2.34	0.00	0.00
300	9	2.15	2.15	0.00	0.00

DRAINAGE AREA Va +Vb - continued  
(FIVE-YEAR EVENT)

Soleno Hydrostor HS180 Chambers

# Chambers	Installed Length (m)	Height (m)	Width (m)	Volume Per Chamber (cu.m)	# End Caps	Length (m)	Volume Per End Cap (cu.m)	Chamber & End Cap Length (m)	Chamber & End Cap Volume (cu.m)
3	2.167	1.156	1.976	3.22	2	0.609	0.43	7.72	10.52

Clear Stone

Dimension Above Chamber (m)	Dimension From Side of Chamber (m)	Dimension From End of Chamber (m)	Clear Stone Length (m)	Available Width (m)	Clear Stone Storage Depth (m)	Clear Stone Volume (cu.m)	Clear Stone 40% Voids (cu.m)	Clear Stone Total Volume (cu.m)
0.15	0.225	0.225	8.17	2.43	1.31	15.36	6.14	
			Chamber Volume (cu.m)	+		Clear Stone Volume (cu.m)	=	Total Volume (cu.m)
			10.52			6.14		16.66

# STORM SEWER DESIGN FORM

## Rational Method

# TWO-YEAR EVENT

## $Q = 2.78 A i C$

November 30, 2022

n = 0.013

52

Location		Areas (ha)				Individual 2.78AC	Accum. 2.78AC	Time of Conc. (min)	Rainfall Intensity i (mm/hr)	Peak Flow Q (L/s)	Pipe Data								Notes		
		Roof C = 0.9	Hard C = 0.9	Gravel C = 0.7	Landscape C = 0.2						Material	Actual Diameter (mm)	Nominal Diameter (mm)	Slope (%)	Length (m)	Capacity (L/s)	Velocity (m/s)	Time of Flow (min)		Ratio Q/Qfull	
From	To																				
CB-1	CB/MH-2		0.0218		0.0003	0.0547	0.0547	10.00	77	4.20	PVC	254.0	250	0.43	16.3	40.7	0.80	0.34	0.10		
CB/MH-2	CB/MH-3	0.0013	0.0190		0.0064	0.0543	0.1091	10.34	76	8.24	PVC	254.0	250	0.43	16.8	40.7	0.80	0.35	0.20		
CB/MH-3	MH-5	0.0055	0.0355		0.0008	0.1030	0.2121	10.69	74	15.75	PVC	254.0	250	0.43	9.8	40.7	0.80	0.20	0.39		
MH-5	MH-6						0.2121	10.89	74	15.60	PVC	304.8	300	0.34	29.6	58.8	0.81	0.61	0.27		
											Existing 300 ST in Alta Vista Drive										
											304.8	300	0.99		100.4	1.38					
CB-A	CB-B	0.0230	0.0581		0.0120	0.2096	0.2096	10.00	77	16.10	PVC	203.2	200	1.00	2.0	34.2	1.06	0.03	0.47		
CB-B	CB/MH-D	0.0251	0.2505		0.0189	0.7001	0.9096	10.03	77	69.76	PVC	304.8	300	1.00	36.9	100.9	1.38	0.44	0.69		
CB-C	CB/MH-D	0.0056	0.0054		0.0013	0.0282	0.0282	10.00	77	2.17	PVC	203.2	200	1.00	21.3	34.2	1.06	0.34	0.06		
Church RDs	CB/MH-D	0.0300				0.0751	0.0751	10.00	77	5.76	PVC	152.4	150	1.00	11.6	15.9	0.87	0.22	0.36		
Hall RDs	CB/MH-D	0.0315				0.0788	0.0788	10.00	77	6.05	PVC	152.4	150	1.00	18.6	15.9	0.87	0.36	0.38		
CB/MH-D	CB/MH-10					0.0000	1.0918	10.48	75	81.91	PVC	304.8	300	1.00	13.5	100.9	1.38	0.16	0.81		
CB/MH-7	CB/MH-10	0.0265	0.0597		0.0212	0.2275	0.2275	10.00	77	17.47	PVC	254.0	250	0.43	22.5	40.7	0.80	0.47	0.43		
CB/MH-10	CB/MH-11	0.0163	0.0162		0.0070	0.0852	1.4044	10.64	74	104.54	PVC	381.0	375	0.35	41.6	108.2	0.95	0.73	0.97		
CB-14	CB/MH-11	0.0407	0.0066		0.0930	0.1701	0.1701	10.00	77	13.06	PVC	254.0	250	0.43	28.1	40.7	0.80	0.58	0.32		
CB-8	CB/MH-9A	0.0157			0.0043	0.0417	0.0417	10.00	77	3.20	PVC	254.0	250	0.43	13.3	40.7	0.80	0.28	0.08		
CB/MH-9A	MH-15	0.0107			0.0050	0.0296	0.0712	10.28	76	5.40	PVC	254.0	250	0.43	6.5	40.7	0.80	0.13	0.13		
MH-15	CB/MH-16	0.0038	0.0202		0.0103	0.0658	0.1370	10.41	75	10.31	PVC	254.0	250	1.50	21.1	76.0	1.50	0.23	0.14		
CB-13B	CB/MH-13A	0.0160			0.0081	0.0445	0.0445	10.00	77	3.42	PVC	254.0	250	0.43	13.1	40.7	0.80	0.27	0.08		
CB/MH-13A	CB/MH-16	0.0100			0.0050	0.0278	0.0723	10.27	76	5.48	PVC	254.0	250	0.43	9.9	40.7	0.80	0.21	0.13		
CB/MH-16	CB/MH-11					0.0000	0.2093	10.65	74	15.58	PVC	254.0	250	1.00	1.8	62.0	1.22	0.02	0.25		
CB/MH-11	MH-17					0.0000	1.7838	11.37	72	128.29	PVC	381.0	375	0.49	33.0	128.0	1.12	0.49	1.00		
MH-17	MH-12					0.0000	1.7838	11.86	70	125.46	PVC	381.0	375	0.47	7.5	125.4	1.10	0.11	1.00		
											Existing 375 ST in Braeside Avenue										
											381.0	375	1.31		209.4	1.84					

Please note the following information regarding the engineering design submission for the above noted site:

- 1) The Servicing Study Guidelines for Development Applications are available at the following address: <https://ottawa.ca/en/city-hall/planning-and-development/how-develop-property/development-application-review-process-2/guide-preparing-studies-and-plans>
- 2) Servicing and site works shall be in accordance with the following documents:
  - Ottawa Sewer Design Guidelines (October 2012) and all the Technical Bulletins including, Technical Bulletin PIEDTB-2016-01 and ISTB-2018-01
  - Ottawa Design Guidelines – Water Distribution (2010) and Technical Bulletins ISD-2010-2, ISDTB-2014-02 and ISTB-2018-02
  - Geotechnical Investigation and Reporting Guidelines for Development Applications in the City of Ottawa (2007)
  - City of Ottawa Slope Stability Guidelines for Development Applications (revised 2012)
  - City of Ottawa Environmental Noise Control Guidelines (January, 2016)
  - City of Ottawa Park and Pathway Development Manual (2012)
  - City of Ottawa Accessibility Design Standards (2012)
  - Ottawa Standard Tender Documents (latest version)
  - Ontario Provincial Standards for Roads & Public Works (2013)
- 3) Record drawings and utility plans are also available for purchase from the City (Contact the City's Information Centre by email at [InformationCentre@ottawa.ca](mailto:InformationCentre@ottawa.ca) or by phone at (613) 580-2424 x.44455).
- 4) The Stormwater Management Criteria, for the subject site, is to be based on the following:
  - i. The 2-yr storm event using the IDF information derived from the Meteorological Services of Canada rainfall data, taken from the MacDonald Cartier Airport, collected 1966 to 1997.
  - ii. For separated sewer system built pre-1970 the design of the storm sewers are based on a 2 year storm.
  - iii. The pre-development runoff coefficient or a maximum equivalent 'C' of 0.5, whichever is less (§ 8.3.7.3).
  - iv. A calculated time of concentration (Cannot be less than 10 minutes).
  - v. Flows to the storm sewer in excess of the 2-year storm release rate, up to and including the 100-year storm event, must be detained on site.
  - vi. For a combined sewer system the maximum C= 0.4 or the pre-development C value, whichever is less. In the absence of other information the allowable release rate shall be based on a 2 year storm event.
  - vii. There may be area specific SWM Criteria within SWM &/or Sub-watershed studies that may apply, please check.

5) Deep Services (Storm, Sanitary & Water Supply)



- i. A plan view of the approximate services may be seen above. Services should ideally be grouped in a common trench to minimize the number of road cuts. The sizing of available future services is:
  - a. Braeside Ave:
    - i. Sanitary – 225 mm (1964).
    - ii. Storm – 375 mm Concrete (1964).
    - iii. Water – 150 mm Iron (1954).

- ii. *Provide existing servicing information and the recommended location for the proposed connections. Services should ideally be grouped in a common trench to minimize the number of road cuts.*
- iii. *Connections to trunk sewers and easement sewers are typically not permitted.*
- iv. *Provide information on the monitoring manhole requirements – should be located in an accessible location on private property near the property line (ie. Not in a parking area).*
- v. *Review provision of a high-level sewer.*
- vi. *Provide information on the type of connection permitted*

Sewer connections to be made above the springline of the sewermain as per:

- a. *Std Dwg S11.1 for flexible main sewers – connections made using approved tee or wye fittings.*
- b. *Std Dwg S11 (For rigid main sewers) – lateral must be less than 50% the diameter of the sewermain,*
- c. *Std Dwg S11.2 (for rigid main sewers using bell end insert method) – for larger diameter laterals where manufactured inserts are not available; lateral must be less than 50% the diameter of the sewermain,*
- d. *Connections to manholes permitted when the connection is to rigid main sewers where the lateral exceeds 50% the diameter of the sewermain. – Connect obvert to obvert with the outlet pipe unless pipes are a similar size.*
- e. *No submerged outlet connections.*

6) Water Boundary condition requests must include the location of the service and the expected loads required by the proposed development. Please provide the following information:

- i. Location of service
- ii. Type of development and the amount of fire flow required (as per FUS, 1999).
- iii. Average daily demand: \_\_\_ l/s.
- iv. Maximum daily demand: \_\_\_ l/s.
- v. Maximum hourly daily demand: \_\_\_ l/s.
- vi. Hydrant location and spacing to meet City's Water Design guidelines.

#### 1. MOECC ECA Requirements –

An MOECC Environmental Compliance Approval (Input Application Type - Industrial Sewage Works or Municipal/Private Sewage Works) may be required for the

proposed development. Please contact Ontario Ministry of the Environment and Climate Change, Ottawa District Office to arrange a pre-submission consultation:

2. Phase 1 ESAs and Phase 2 ESAs must conform to clause 4.8.4 of the Official Plan that requires that development applications conform to Ontario Regulation 153/04.

7) General comments –

- i. Water supply redundancy will be required for more than 50 m<sup>3</sup>/day water demand.
- ii. The storm sewer may be discharging to Sawmill Creek subwatershed. Please verify.
- iii. Provide a Stormwater quality control discussion in the report and consult with Rideau Valley Conservation Authority (RVCA) for stormwater quality requirement.
- iv. It was noticed servicing for the Braeside House are connected through the proposed development, therefore the servicing may need re-alignment. Please explore and verify as required.
- v. The proposed building is connected to the existing building, therefore check the fire flow demand. The connection may have to design with fire resistance wall to meet the fire flow requirement. Please verify.

Should you have any questions or require additional information, please contact me directly by email at [sharif.sharif@ottawa.ca](mailto:sharif.sharif@ottawa.ca).



## City of Ottawa Servicing Study Checklist

### General Content

**Executive Summary (for large reports only):** not applicable

**Date and revision number of the report:** see page 1 of Servicing Brief and Stormwater Management Report

**Location map and plan showing municipal address, boundary, and layout of proposed development:** see drawings C-1 to C-7

**Plan showing the site and location of all existing services:** see drawings C-1 to C-7

**Development statistics, land use, density, adherence to zoning and official plan, and reference to applicable subwatershed and watershed plans that provide context to which individual developments must adhere:** not applicable

**Summary of Pre-consultation Meetings with City and other approval agencies:** not available

**Reference and confirm conformance to higher level studies and reports ( Master Servicing Studies, Environmental Assessments, Community Design Plans), or in the case where it is not in conformance, the proponent must provide justification and develop a defensible design criteria:** not applicable

**Statement of objectives and servicing criteria:** see page 2 of Servicing Brief and Stormwater Management Report

**Identification of existing and proposed infrastructure available in the immediate area:** see drawings C-1 to C-7

**Identification of Environmentally Significant Areas, watercourses and Municipal Drains potentially impacted by the proposed development ( Reference can be made to the Natural Heritage Studies, if available).** see drawings C-1 to C-7

**Concept level master grading plan to confirm existing and proposed grades in the development and drainage, soil removal and fill constraints, and potential impacts to neighbouring properties. This is also required to confirm that the proposed grading will not impede existing major system flow paths:** not applicable

**Identification of potential impacts of proposed piped services on private services (such as wells and septic fields on adjacent lands) and mitigation required to address potential impacts:** not applicable

**Proposed phasing of the development, if applicable:** not applicable

**Reference to geotechnical studies and recommendations concerning servicing:** see note 1.5 on drawing C-5

**All preliminary and formal site plan submissions should have the following information:**

- **Metric scale:** included
- **North arrow:** included
  - **(including construction North):** not included

- **Key Plan:** included
- **Name and contact information of applicant and property owner:** not available
- **Property limits:** included
  - **including bearings and dimensions:** not included
- **Existing and proposed structures and parking areas:** included
- **Easements, road widening and rights-of-way:** included
- **Adjacent street names:** included

#### **Development Servicing Report: Water**

**Confirm consistency with Master Servicing Study, if available:** not applicable

**Availability of public infrastructure to service proposed development:** see page 2 & 3 of Servicing Brief

**Identification of system constraints:** see page 2 & 3 of Servicing Brief

**Confirmation of adequate domestic supply and pressure:** see page 2 & 3 of Servicing Brief

**Confirmation of adequate fire flow protection and confirmation that fire flow is calculated as per the Fire Underwriter's Survey. Output should show available fire flow locations throughout the development:** see page 2,3 & 5 of Servicing Brief

**Provide a check of high pressures. If pressure is found to be high, an assessment is required to confirm the application of pressure reducing valves:** see page 2 of Servicing Brief

**Definition of phasing constraints. Hydraulic modeling is required to confirm servicing for all defined phases of the project including the ultimate design:** not applicable

**Address reliability requirements such as appropriate location of shut-off valves:** not applicable

**Check on the necessity of a pressure zone boundary modification:** not applicable

**Reference to water supply analysis to show that major infrastructure is capable of delivering sufficient water for the proposed land use. This includes data that shows that the expected demands under average day, peak hour and fire flow conditions provide water within the required pressure range:** not applicable

**Description of the proposed water distribution network, including locations of proposed connections to the existing systems, provisions for necessary looping, and appurtenances (valves, pressure reducing valves, valve chambers, and fire hydrants) including special metering provisions:** not applicable

**Description of off-site required feeder mains, booster pumping stations, and other water infrastructure that will be ultimately required to service proposed development, including financing, interim facilities, and timing of implementation:** not applicable

**Confirmation that water demands are calculated based on the City of Ottawa Design Guidelines:** see page 3 of Servicing Brief

**Provision of a model schematic showing the boundary conditions locations, streets , parcels, and building locations for reference:** not applicable

#### **Development Servicing Report: Wastewater**

**Summary of proposed design criteria:** see page 3 of Servicing Brief

**(Note: Wet-weather flow criteria should not deviate from the City of Ottawa Sewer Design Guidelines. Monitored flow data from relatively new infrastructure cannot be used to justify capacity requirements for proposed infrastructure):** not applicable

**Confirm consistency with Master Servicing Study and /or justification for deviations:** not applicable

**Consideration of local conditions that may contribute to extraneous flows that are higher than the recommended flows in the guidelines. This includes groundwater and soil conditions, and age and conditions of sewers:** not applicable

**Descriptions of existing sanitary sewer available for discharge of wastewater from proposed development:** see page 3 of Servicing Brief

**Verify available capacity in downstream sanitary sewer and / or identification of upgrades necessary to service the proposed development. (Reference can be made to previously completed Master Servicing Study if applicable):** not applicable

**Calculations related to dry-weather and wet-weather flow rates from the development in standard MOE sanitary sewer design table (Appendix C) format.** see page 9 of Servicing Brief

**Description of proposed sewer network including sewers, pumping stations, and forcemains:** see page 3 of Servicing Brief

**Discussion of previously identified environmental constraints and impact on servicing (environmental constraints are related to limitations imposed on the development in order to preserve the physical condition of watercourses, vegetation, soil cover, as well as protecting against water quantity and quality):** not applicable

**Pumping stations: impacts of proposed development on existing pumping stations or requirements for new pumping station to service development:** not applicable

**Forcemain capacity in terms of operational redundancy, surge pressure and maximum flow velocity:** not applicable

**Identification and implementation of the emergency overflow from sanitary pumping stations in relation to the hydraulic grade line to protect against basement flooding:** not applicable

**Special considerations such as contamination, corrosive environment etc:** not applicable

#### **Development Servicing Report: Stormwater Checklist**

**Description of drainage outlets and downstream constraints including legality of outlets (i.e. municipal drain, right-of-way, watercourse, or private property):** see page 4 of Servicing Brief and Stormwater Management Report

**Analysis of available capacity in existing public infrastructure.** not applicable

**A drawing showing the subject lands, its surroundings, the receiving watercourse, existing drainage patterns, and proposed drainage pattern:** see drawing C-3 & C-7

**Water quality control objective (e/g/ controlling post-development peak flows to pre-development level for storm events ranging from the 2 or 5 year event (dependent on the receiving sewer design) to 100 year return period); if other objectives are being applied, a rationale must be included with reference to hydrologic analyses of the potentially affected subwatersheds, taking into account long-term cumulative effects:** see Stormwater Management Report Servicing Brief and Stormwater Management Report

**Water Quality control objective (basic, normal or enhanced level of protection based on the sensitivities of the receiving watercourse) and storage requirements:** Servicing Brief and Stormwater Management Report

**Descriptions of the references and supporting information.**  
**Set-back from private sewage disposal systems.** not applicable

**Watercourse and hazard lands setbacks:** not applicable

**Record of pre-consultation with the Ontario Ministry of Environment and the Conservation Authority that has jurisdiction on the affected watershed:** the pre-application consultation record is not yet been issued

**Confirm consistency with sub-watershed and Master Servicing Study, if applicable study exists:** not applicable

**Storage requirements (complete with calculations) and conveyance capacity for minor events (1:5 year return period) and major events (1:100 year return period).** see drawings C-1 to C-7 and Servicing Brief and Stormwater Management Report

**Identification of watercourses within the proposed development and how watercourses will be protected, or , if necessary, altered by the proposed development with applicable approvals.** see drawings C-1 to C-7 and Servicing Brief and Stormwater Management Report

**Calculate pre and post development peak flow rates including a description of existing site conditions and proposed impervious areas and drainage catchments in comparison to existing conditions:** see Servicing Brief and Stormwater Management Report

**Any proposed diversion of drainage catchment areas from one outlet to another. :** not applicable

**Proposed minor and major systems including locations and sizes of stormwater trunk sewers, and stormwater management facilities. :** not applicable

**If quantity control is not proposed, demonstration that downstream system has adequate capacity for the post-development flows up to and including the 100-year return period storm event:** not applicable

**Identification of potential impacts to receiving watercourses:** Servicing Brief and Stormwater Management Report

**Identification of municipal drains and related approval requirements. :** not applicable

**Descriptions of how the conveyance and storage capacity will be achieved for the development:** see page 5 & 6 of Servicing Brief and Stormwater Management Report

**100 year flood levels and major flow routing to protect proposed development from flooding for establishing minimum building elevations (MBE) and overall grading:**

**Inclusion of hydraulic analysis including hydraulic grade line elevations. :** not applicable

**Description of approach to erosion and sediment control during construction for the protection of receiving watercourses of drainage corridors:** see notes 2.1 to 2.5 on drawing C-5

**Identification of floodplains – proponent to obtain relevant floodplain information from the appropriate Conservation Authority. The proponent may be required to delineate floodplains elevations to the satisfaction of the Conservation Authority if such information is not available or if information does not match current:** not applicable

**Identification of fill constraints related to floodplain and geotechnical investigation. :** not applicable

#### **Approval and Permit Requirements: Checklist**

**The Servicing Study shall provide a list of applicable permits and regulatory approvals necessary for the proposed development as well as the relevant issues affecting each approval. The approval and permitting shall include but not be limited to the following:**

**Conservation Authority as the designated approval agency for modification of floodplain, potential impact on fish habitat, proposed works in or adjacent to a watercourse, cut/fill permits and Approval under Lakes and Rivers Improvement Act. The Conservation Authority is not approval authority for the Lakes and Rivers Improvement Act. Where there are Conservation Authority regulations in place, approval under the Lakes and Rivers Improvement Act is not required, except in cases of dams as defined in the Act: see page 19 of Servicing Brief and Stormwater Management Report**

**Application for Certificate of Approval (CofA) under the Ontario Water Resources Act:**

**Changes to Municipal Drains. :** not applicable

**Other permits (National Capital commission, Parks Canada, public Works and Government Services Canada, Ministry of transportation etc.) :** not applicable

#### **Conclusion Checklist**

**Clearly stated conclusions and recommendations:** see page 6 & 7 of Servicing Brief

**Comments received from review agencies including the City of Ottawa and information on how the comments were addressed. Final sign-off from the responsible reviewing agency.**

**All draft and final reports shall be signed and stamped by a professional Engineer registered in Ontario:** included