

TRANSPORTATION IMPACT ASSESSMENT

**PROPOSED SELF STORAGE DEVELOPMENT
3149 HAWTHORNE ROAD
CITY OF OTTAWA**

**PREPARED FOR:
ACCESS PROPERTY DEVELOPMENT INC.**

**PREPARED BY:
C.F. CROZIER & ASSOCIATES INC.
211 YONGE STREET, SUITE 600
TORONTO, ON M5B 1M4**

**ORIGINAL TIA: FEBRUARY 2022
CURRENT: MAY 2023**

CFCA FILE NO. 2112-6007

The material in this report reflects best judgment in light of the information available at the time of preparation. Any use which a third party makes of this report, or any reliance on or decisions made based on it, are the responsibilities of such third parties. C.F. Crozier & Associates Inc. accepts no responsibility for damages, if any, suffered by any third party as a result of decisions made or actions based on this report.





Certification Form for TIA Study PM

TIA Plan Reports

On 14 June 2017, the Council of the City of Ottawa adopted new Transportation Impact Assessment (TIA) Guidelines. In adopting the guidelines, Council established a requirement for those preparing and delivering transportation impact assessments and reports to sign a letter of certification.

Individuals submitting TIA reports will be responsible for all aspects of development-related transportation assessment and reporting, and undertaking such work, in accordance and compliance with the City of Ottawa's Official Plan, the Transportation Master Plan and the Transportation Impact Assessment (2017) Guidelines.

By submitting the attached TIA report (and any associated documents) and signing this document, the individual acknowledges that s/he meets the four criteria listed below.

CERTIFICATION

- I have reviewed and have a sound understanding of the objectives, needs and requirements of the City of Ottawa's Official Plan, Transportation Master Plan and the Transportation Impact Assessment (2017) Guidelines;
- I have a sound knowledge of industry standard practice with respect to the preparation of transportation impact assessment reports, including multi modal level of service review;
- I have substantial experience (more than 5 years) in undertaking and delivering transportation impact studies (analysis, reporting and geometric design) with strong background knowledge in transportation planning, engineering or traffic operations; and
- I am either a licensed¹ or registered² professional in good standing, whose field of expertise
 - is either transportation engineering
 - or transportation planning .

^{1,2} License of registration body that oversees the profession is required to have a code of conduct and ethics guidelines that will ensure appropriate conduct and representation for transportation planning and/or transportation engineering works.

Dated at Toronto this 18 day of May, 2023.
(City)

Name : Peter Apasnore

Professional title: Transportation Engineer



Signature of individual certifier that s/he meets the above criteria

Office Contact Information (Please Print)	
Address:	<u>211 Yonge Street, Suite 600</u>
City / Postal Code:	<u>M5B 1M4</u>
Telephone / Extension:	<u>416-477-3392</u>
E-Mail Address:	<u>papasnore@cfcrozier.ca</u>

Stamp



Revision Number	Date	Comments
Rev.0	September 2021	TIA Issued for 1 st Submission (City reviewed Steps 1-3)
Rev. 1	February 2022	TIA Issued for 2 nd Submission (Fulfilling City request for Step 4 - Analysis Report)
Rev. 2	May 2023	Issued for 3 rd Submission

Executive Summary

Background

C.F. Crozier & Associates Inc. (Crozier) was retained by Access Property Development Inc. to prepare a Transportation Impact Assessment (TIA) in support of the Site Plan Application for the proposed self-storage development at 3149 Hawthorne Road in the City of Ottawa. The purpose of this TIA study is to assess the site specific requirements as well as impacts of the proposed development on the boundary road network and to recommend required mitigation measures, if warranted. The purpose of this TIA resubmission is to address comments received from the City of Ottawa staff via email correspondence (dated February 2022). A comment response letter has also been prepared as part of this resubmission, outlining how each of the City comments have been addressed.

The development proposal includes:

- A 4-storey industrial self-storage facility consisting of a total 10,842 m² Gross Floor Area (GFA).
- A total of 34 parking spaces and 2 loading spaces are proposed on the site with an additional 66 parking spaces to be shared with the existing self-storage facility.
- The site is to be served jointly by the existing full moves access at Hawthorne Road immediately south which currently serves the existing 3169 Hawthorne Road self-storage.

The proposed self-storage development is projected to generate a total of 15 and 26 person-trips during the weekday a.m. and p.m. peak hours, respectively.

Existing & Future Traffic Operations

Under the existing (2021), 2026 future background, and 2026 future total conditions, the study intersections of Hawthorne Road with Ages Drive and the existing site access are forecast to operate below capacity at a LOS "B" or better during the a.m. and p.m. peak hours. The LOS for both intersections under all study horizons is better than the target LOS "D" desired per the City's Multimodal LOS guidelines.

Similarly, under existing conditions and the future study horizons, the 95th percentile queues for the eastbound left turn at the Hawthorne Road and Ages Drive intersection is expected to occasionally exceed the storage onto the taper during the peak hours. The proposed development does not contribute trips to the eastbound left turn movement.

The proposed site access is projected to operate safely without any issues related to sight-lines, truck movements and corner clearance and spacing. Further, the access is not expected to develop recurring collision patterns, supporting the continued full-moves configuration as is existing.

The combined vehicle parking supply of 100 spaces serving both 3149 and 3169 Hawthorne Road satisfies the City's Zoning By-Law requirement for the site. Additionally, the site provides the required barrier free accessible parking spaces and bicycle parking spaces. Further, per the City's Zoning By-Law, the loading space requirements for the site is met.

Conclusion

The proposed self-storage at 3149 Hawthorne Road is forecast to have an immaterial impact on traffic operations at the boundary intersections. The Site Plan Application can be supported from a traffic operations perspective as the boundary road system is forecast to adequately accommodate the increase in traffic volumes attributable to the proposed development.

TABLE OF CONTENTS

Executive Summary	iii
1.0 Introduction	1
1.1 Background	1
1.2 Subject Property.....	1
1.3 Development Proposal	1
2.0 Screening	1
3.0 Scoping	2
3.1 Existing Conditions	2
3.1.1. Road Descriptions.....	2
3.1.2. Intersections.....	2
3.1.3. Adjacent Driveways	3
3.1.4. Existing Transit Services	3
3.1.5. Existing Active Transportation Facilities	4
3.1.6. Area Traffic Management	4
3.1.7. Turning Movement Counts	4
3.1.8. Collision History	4
3.2 Future Planned Conditions	5
3.3 Study Area, Horizons and Time Periods	5
3.4 Exemptions Review	6
4.0 Forecasting	6
4.1 Trip Generation and Mode Share Target.....	6
4.1.1. Proposed 3149 Hawthorne Road Site Trip Forecast.....	6
4.1.2. Existing 3169 Hawthorne Road Site Trip Forecast	7
4.2 Trip Distribution and Assignment	8
4.3 Background Growth.....	8
4.4 Background Developments	8
4.5 Future Background and Total Traffic Volumes	9
4.6 Demand Rationalization	9
5.0 Analysis	10
5.1 Development Design	10
5.1.1. Design for Sustainable Modes	10
5.1.2. Circulation and Access.....	10
5.2 Parking Review	10
5.2.1. Parking Supply	10
5.3 Boundary Street Design.....	11
5.4 Access Intersection Review	12
5.5 Intersection Levels of Service	12
5.5.1. Existing Intersection Operations	12
5.5.2. Future Background Intersection Operations	13
5.5.3. Future Total Intersection Operations	14
5.6 Transit.....	14
6.0 Conclusions and Recommendations	15

LIST OF FIGURES

- Figure 1:** Site Location
- Figure 2:** Site Plan
- Figure 3:** 2021 Existing Traffic Volumes
- Figure 4:** Site Generated Trip Distribution
- Figure 5:** Site Generated Trip Assignment
- Figure 6:** Background Developments Traffic
- Figure 7:** 2026 Future Background Traffic
- Figure 8:** 2026 Total Traffic Volumes

LIST OF APPENDICES

- Appendix A:** Correspondence
- Appendix B:** Screening Form
- Appendix C:** Municipal and External Report Excerpts
- Appendix D:** Turning Movement Counts
- Appendix E:** Collision Data
- Appendix F:** TDM Checklist
- Appendix G:** Truck Turning Diagrams
- Appendix H:** Level of Service Excerpts
- Appendix I:** Synchro Capacity Analysis

1.0 Introduction

1.1 Background

C.F. Crozier & Associates Inc. (Crozier) was retained by Access Property Development Inc. to prepare a Transportation Impact Assessment (TIA) in support of the Site Plan Application for the proposed industrial development at 3149 Hawthorne Road in the City of Ottawa.

This TIA study assesses the site specific requirements as well as impacts of the proposed development on the boundary road network and provides recommendations on required mitigation measures, if warranted. The TIA was conducted in accordance with the City of Ottawa's "Transportation Impact Assessment Guidelines (2017)". A terms of reference correspondence between Crozier and City of Ottawa staff further confirmed the scope of the TIA.

The purpose of this TIA resubmission is to address comments received from the City of Ottawa staff via email correspondence (dated February 2022). A comment response letter has also been prepared as part of this resubmission, outlining how each of the City comments have been addressed. The terms of reference and correspondence with the City, including the latest comments related to the first TIA submission are presented in **Appendix A**.

1.2 Subject Property

The subject property covers an area of approximately 0.73 hectares and currently consists of a vacant vegetated lot and a small self-storage access building on the southwest corner. The property, located in an industrial area, is bounded by Ages Drive to the north, an existing access to 3169 Hawthorne Road at the south, an existing self-storage development to the east and Hawthorne Road to the west. The surrounding area is characterized by commercial and industrial land uses. Refer to **Figure 1** for the site location and surrounding area.

1.3 Development Proposal

According to the site plan prepared by Architecture 49 (dated May 10, 2023), the proposed development includes the following:

- A 4-storey industrial self-storage facility consisting of a total 10,842 m² Gross Floor Area (GFA)
- A total of 34 parking spaces and 2 loading spaces are proposed on the site with an additional 66 parking spaces to be shared with the existing self-storage facility on the eastside.
- The site is to be served by the existing full moves access connection to Hawthorne Road immediately south which currently serves the 3169 Hawthorne Road self-storage facility. Upon completion of the proposed development, the site access connection is anticipated to serve both 3149 and 3169 Hawthorne Road properties

Refer to **Figure 2** for the site plan.

2.0 Screening

The City's TIA Guidelines contain a screening form highlighting the criteria based on which a TIA is required for a proposed development. There are three triggers, which includes the trip generation,

location, and safety. A TIA study is required if at least one of the triggers is satisfied.

Trip Generation Trigger – The proposed industrial development is expected to generate 15 and 26 two-way person trips during the a.m. and p.m. peak hours respectively, less than the trip generation trigger threshold of 60. However, the development has a total GFA that exceeds 5,000 m², which meets the trip generation trigger of 5,000m².

Location Triggers – The site proposes utilizing an existing access connection at 3169 Hawthorne Road. Additionally, the subject property is not located in a Design Priority Area (DPA) or Transit-Oriented Development (TOD) zone. Therefore, this trigger is not satisfied.

Safety Triggers – This trigger is satisfied as the existing driveway (that will serve the proposed site) is within 150m of the Hawthorne Road and Ages Street Intersection. Therefore, the safety trigger is satisfied.

Given that the Trip Generation and Safety trigger are satisfied, a TIA is required as requested by the City. Refer to **Appendix B** for the completed Screening Form.

3.0 Scoping

3.1 Existing Conditions

3.1.1. Road Descriptions

Hawthorne Road is a five-lane undivided arterial roadway and is classified as a truck route, allowing full loads. It runs north-south and has a posted speed limit of 70km/h. The road has two lanes per travel direction and a two-way left turn median lane. Hawthorne Road is a designated spinal bike route with on-street bike lanes on either side of the roadway. Further, for the segment adjacent the site, there is a 2 m sidewalk on the west side and a narrow paved shoulder on the east side of a street near the subject site. North of the Hawthorne Road and Ages Drive intersection, there exists 2 m sidewalks on both sides of the road which additionally serve as stop locations for OC Transpo transit services. Hawthorne Road is under the jurisdiction of the City of Ottawa.

Ages Drive is a two-lane local road. The segment of the roadway adjacent to the site is aligned west-east and has an assumed jurisdictional speed limit of 50km/h, given no posted speed limits exist. The roadway has curbs on both sides and no pedestrian or bicycle facilities. Ages Drive is under the jurisdiction of the City of Ottawa. The segment of Ages Drive east of Hawthorne Road terminates within an industrial development, essentially serving as a private access. Refer to Municipal Excerpts in **Appendix C**.

3.1.2. Intersections

As confirmed with the City, this study analyzes the following intersections:

- Hawthorne Road and Ages Drive
- Hawthorne Road and the existing 3169 Hawthorne Road Site Access

The Hawthorne Road and Ages Drive intersection is a four-legged signalized intersection. The Hawthorne Road north and south approaches both have an exclusive left turn lane, two exclusive

through lanes and an exclusive right-turn lane. The exclusive right turn lane of the north approach is channelized while the south approach right turn lane is not. The Ages Drive west approach has an exclusive left turn lane and a shared through/ right turn lane, with the right turn channelized. Though pavement markings are faded, the Ages Drive east approach has an exclusive left turn storage lane and a single shared lane for right and through traffic. The intersection features pedestrian crosswalks at all four approaches.

The Hawthorne Road and the existing 3169 Hawthorne Road Site Access is a standard driveway/roadway connection. At the Hawthorne Road north approach, the road configuration includes two through lanes and a two-way left-turn lane. The Hawthorne road south approach has an exclusive through lane and a shared lane for through and right turn movements. The east approach site access connection has a single lane for left and right turn movements.

3.1.3. Adjacent Driveways

There are a few driveway connections to Hawthorne Road within 200m of the segment of the road fronting the site herein. The driveways, as listed below are within 200 m of the site along Hawthorne Road and currently serve industrial and commercial land uses.

- One commercial driveway for 3150 Hawthorne Road
- One commercial driveway for 3180 Hawthorne Road
- One commercial driveway for 3190 Hawthorne Road
- One commercial driveway for 2610 Glenfield Drive
- Two commercial driveways for 3199 Hawthorne Road
- One industrial driveway for 3220 Hawthorne Road

Further, there are several driveways along Ages Drive in proximity to the subject site. The driveways, as listed below are within 200 m of the site and currently serve industrial and commercial land uses.

- Two industrial driveways for 3103 Hawthorne Road
- Two industrial driveways for 3105 Hawthorne Road
- Two commercial driveways for 3150 Hawthorne Road
- Two industrial driveways for 1301 Ages Drive
- One industrial driveway for 3070 Hawthorne Road

3.1.4. Existing Transit Services

A single transit bus route by OC Transpo operates serves near the site on Hawthorne. **Table 1** provides details regarding the existing bus route 47 operation.

Table 1: Existing Transit Services

Route	Span	Time of Operation	Peak Hour Headways	Bus Stops Near Site
Bus Route 47 (OC Transpo)	Hydro Road and St. Laurent Station	Monday to Friday AM Peak: 5:45 - 9:00 PM Peak: 3:00 - 6:25	30 minutes	2 stops serving both directions. Both are within 100m of the site.

Hawthorne Road has a standard 2 m sidewalk on both sides of the road where the bus stops are located. The bus route 47 only operates from Hydro Road to St. Laurent Station during the p.m. peak hours and the reverse direction during the a.m. peak hours.

Refer to **Appendix C** for transit service information.

3.1.5. Existing Active Transportation Facilities

As previously described in **Section 3.1.1.**, Hawthorne Road has a standard 2 m sidewalk on both sides of the road where the OC Transpo Bus Route 47 stops are located. Beyond this, there are sidewalks present on all corners of the Hawthorne Road and Ages Drive intersection, as well as crosswalks to permit pedestrian crossings. South of the intersection near the proposed development, there exists a standard 2m sidewalk on the west side of Hawthorne Road, and a narrow paved shoulder on the east side of the road. In addition, Hawthorne Road has non-separated bicycle lanes on both sides of the roadway. Hawthorne Road is classified as a spine route per the City of Ottawa Transportation Master Plan – Map 1 “Cycling Network – Primary Urban”.

Ages Drive has no existing active transportation facilities.

3.1.6. Area Traffic Management

There are no Area Traffic Management measures within the study area nor are there any Area Traffic Management studies in progress.

3.1.7. Turning Movement Counts

At the time of this study, due to the impact of the Covid-19 situation on travel pattern; existing counts were not undertaken; instead, the most recent traffic data available at the City was obtained and used for analysis. The City had counts for only the Hawthorne Road and Ages Drive intersection and these were undertaken on Wednesday January 25, 2017. The counts were conducted between 7 a.m. and 6 p.m., with time periods of 7:45 – 8:45 a.m. and 3:45 – 4:45 p.m. being identified as the a.m. and p.m. peak hours, respectively. The turning movement counts included vehicle, bicycle, and pedestrian movements at the study intersection. For turning movement count data, refer to **Appendix D**.

The turning movement count (TMC) data was used to estimate 2021 existing conditions at the Hawthorne Road and Ages Drive study intersection. Similarly, through movement volumes on Hawthorne Road at the existing site access were extrapolated from the Hawthorne Road at Ages Drive intersection. For ingress and egress turning movements at the existing site access pertaining the existing development, a trip generation forecast was conducted. Refer to **Sections 4.1 and 4.2** herein for details of the trip generation and distribution for the existing self-storage. The existing 2021 traffic volumes are provided in **Figure 3**.

3.1.8. Collision History

Historical collision data was obtained from the City of Ottawa for the most recent five year period available between January 1, 2014, to December 31, 2018. A collision analysis was conducted to identify any existing collision trends in the area, with the critical threshold per the City's guidelines being more than six collisions within a five-year time frame for any collision type. The collision data is included in **Appendix E. Table 2** outlines the collisions by type, severity, and weather conditions.

Table 2: Collision Data

Location	Collision Type ^[1]	Severity	Weather Conditions
Hawthorne Road and Ages Drive Intersection	Angle – 5 Rear end – 2 Sideswipe - 1 Turning Movement – 4 SMV other – 2 Total - 14	Non-fatal Injury - 1 Property Damage (PD) Only –13 Total - 14	Clear – 9 Snow – 4 Rain – 1 Total - 14
Hawthorne Road segment between Ages Drive and Stevenage Drive	Sideswipe – 2 Turning Movement – 1 SMV other – 1 Total - 4	Property Damage (PD) Only – 4 Total - 4	Clear - 2 Snow – 2 Total - 4

Notes:

[1] "SMV other" is short for "Single Motor Vehicle other" collision impact type.

As outlined in **Table 2**, the intersection of Hawthorne Road and Ages Drive and the roadway segment of Hawthorne Road between Ages Drive and Stevenage Drive has less collisions than the City threshold. Further, it is noted that, when including the existing site access, there are 7 total accesses on Hawthorne Road between Ages Drive and Stevenage Drive, and only 4 property damage only collisions recorded over 5 years. This indicates that the existing access is expected continue to operate safely for the development proposed herein.

3.2 Future Planned Conditions

The TMP Map 3 "Rapid Transit and Transit Priority Network - Ultimate" identifies a bus rapid transit (BRT) project with a station at the Russell Road and Walkley Road intersection. The BRT route is a primarily east-west corridor which intends to connect to the City's rapid transit system. Currently, the first phase of the project on Baseline Road has completed the Transit Project Assessment Process (TPAP), and is currently in the final design stages. Should the bus rapid transit line be implemented at Russell Road and Walkley Road, the route will provide enhanced transit service to the subject property. Refer to **Appendix C** for Transportation Master Plan excerpts.

Further, the City is currently updating their Transportation Master Plan which may include additional transportation network improvements in the areas surrounding the site.

3.3 Study Area, Horizons and Time Periods

As confirmed through a terms of reference correspondence with the City of Ottawa, the study area includes the intersections listed below.

- Hawthorne Road and Ages Drive
- Hawthorne Road and the existing 3169 Hawthorne Road Site Access

Further, as confirmed with the City, the study intersections are analyzed based on the weekday a.m. and p.m. peak hours for the existing (2021) and 5-year horizon (2026).

The terms of reference and correspondence with the City are included in **Appendix A**.

3.4 Exemptions Review

As required per module 2.3 of the City's TIA Guidelines, this section reviews possible exemptions that may be applied to the TIA for the proposed development herein. **Table 3** presents a summary review of the development and network conditions as well as the associated exemption status.

Table 3: Potential Exemptions Review

Module	Element	Exemption Condition	Development Status
Design Review Component			
Development Design	Circulation and Access	Only required for Site Plans	Not exempt
	New Street Networks	Only required for Plans of Subdivision	Exempt
Parking	Parking Supply	Only required for Site Plans	Not exempt
	Spillover Parking	Only required for Site Plans where parking supply is 15% below unconstrained demand	Exempt
Transportation Demand Management	All elements	Not required for Site Plans expected to have fewer than 60 employees and/or students on location at any given time	Exempt
Neighbourhood Traffic Management	Adjacent Neighbourhoods	Only required when the development relies on local or collector streets for access and total volumes exceed ATM capacity thresholds	Exempt
Network Concept	-	Only required when proposed development generates more than 200 person-trips during the peak hour in excess of the equivalent volume permitted by established zoning	Exempt

Therefore, the TIA analysis section will include a review of circulation and access, as well as parking supply and demand.

4.0 Forecasting

The proposed development will result in new traffic turning movements on the boundary road network that would otherwise not exist. This section presents the generated trips and trip assignment through the study intersections. The forecasting and trip assignment methodology conforms to modules 3.1 and 3.2 of the TIA Guidelines.

4.1 Trip Generation and Mode Share Target

4.1.1. Proposed 3149 Hawthorne Road Site Trip Forecast

Trip generation for the proposed development was forecasted using the Institute of Transportation Engineers (ITE) Trip Generation Manual, 10th Edition and the City of Ottawa TRANS Trip Generation Manual. A self storage development falls under Land Use Category (LUC) 151 "Mini-Warehouse" according to the ITE Trip Generation Manual. The results of the ITE trip generation are shown in **Table 4** below.

Table 4: 3149 Hawthorne Road ITE Vehicle Trip Generation

Site	ITE Land Use Category	Gross Floor Area (GFA)	Peak Hour	Number of Trips		
				Inbound	Outbound	Total
3149 Hawthorne Road	LUC 151: Mini-Warehousing	10,842 m ²	A.M.	7	5	12
			P.M.	9	11	20

The vehicle-trips were then converted to person-trips using the conversion factor of 1.28 for non-residential land uses as noted in the City of Ottawa’s TRANS Trip Generation Manual.

As per the City of Ottawa TIA Guidelines, the person trips were distributed by modes. The site is located within the “Hunt Club” district, therefore, mode splits from Table 12 of the “TRANS Trip Generation Manual – Summary Report” for the “Hunt Club” district was used for modal distribution.

Table 5: 3149 Hawthorne Road Person Trips by Travel Mode

Mode	Mode Split	A.M. Peak Hour		P.M. Peak Hour	
		Inbound	Outbound	Inbound	Outbound
Total Person Trips		9	6	12	14
Auto Driver	83%	8	5	10	11
Auto Passenger	5%	0	0	1	1
Transit	10%	1	1	1	2
Cycling	1%	0	0	0	0
Walking	1%	0	0	0	0

As shown in **Table 5**, the proposed development is projected to generate 15 and 26 person-trips in the a.m. and p.m. peak hour, respectively.

4.1.2. Existing 3169 Hawthorne Road Site Trip Forecast

As noted in **Section 3.1.7**, no traffic data was available at the existing site access and counts were not undertaken due to the impact of the Covid-19 on travel patterns. Therefore, trips were generated and distributed for the existing self-storage (3169 Hawthorne Road) similar to the proposed self-storage herein.

Table 6: ITE Vehicle Trip Generation

Site	ITE Land Use Category	Gross Floor Area (GFA)	Peak Hour	Number of Trips		
				Inbound	Outbound	Total
3169 Hawthorne Road	LUC 151: Mini-Warehousing	4,813 m ²	A.M.	3	2	5
			P.M.	5	5	10

As shown in **Table 6**, the results of the ITE Trip Generation for the existing 3169 Hawthorne Road self-storage facility estimates a trip generation of 5 and 10 vehicle trips in the a.m. and p.m. peak hour, respectively.

Table 7: 3169 Hawthorne Road Person Trips by Travel Mode

Mode	TRANS Survey Mode Split	A.M Peak Hour		P.M. Peak Hour	
		Inbound	Outbound	Inbound	Outbound
Total Person Trips		4	3	6	6
Auto Driver	83%	3	3	5	5
Auto Passenger	5%	0	0	0	0
Transit	10%	1	0	1	1
Cycling	1%	0	0	0	0
Walking	1%	0	0	0	0

As shown in **Table 7**, the existing 3169 Hawthorne Road self-storage facility is estimated to generate 7 and 12 person-trips in the a.m. and p.m. peak hour, respectively.

4.2 Trip Distribution and Assignment

The development generated trips and the existing 3169 Hawthorne Road self-storage trips were distributed based on the existing and expected travel patterns. The general distributions are noted below:

- 70% to/from Hawthorne Road (north approach)
- 30% to/from Hawthorne Road (south approach)

The trip distribution and trip assignment for the proposed development are presented in **Figures 4 and 5**, respectively. The trip assignment for the existing 3169 Hawthorne Road self-storage facility at the access is presented as part of **Figure 3**.

4.3 Background Growth

As confirmed through correspondence with the City of Ottawa staff, growth rates for Hawthorne Road were obtained from the Master TIA for the National Capital Business Park prepared by Novatech (dated May 2020). Per the excerpts presented in **Appendix C**, the master TIA by Novatech established a growth rate of -0.5% to 1.5% per year on arterial roadways within the study area based on a review of the City's Regional traffic forecast model. Further, per Exhibit 2.10 of the TMP (2013), the 'Inner Suburbs' (where the site is located) are projected to have a population and employment growth rates of approximately 0.3% and 1.2% per year, respectively. Similar to the master TIA, a 1% annual background growth rate compounded annually was applied to the existing traffic along Hawthorne Road. No growth rate was applied to Ages Drive as it is a local street with a short span.

4.4 Background Developments

As confirmed through correspondence with the City of Ottawa staff, background development traffic was obtained from the Master TIA Study for the National Capital Business Park. The study considered the impacts of the planned National Capital Business Park developments, located in the Hawthorne Road and Russell Road industrial area. The background traffic volumes on Hawthorne Road at the study intersections are included as a single background development, however, these traffic volumes encompass the following background developments which have been incorporated in this study:

- Site 1 (portion of 4120 Russell Road– Industrial warehouse (8,325m² GFA)
- Site 2 (portion of 4120 Russell Road) – Two industrial warehouses (17,400m² GFA)
- Site 3 (4055 Russell Road) – Three industrial warehouses (75,675m² GFA)

Excerpts of the master TIA trips are provided in **Appendix C**. The background development traffic is presented in **Figure 6**.

The background developments identified in the Master TIA Study for the National Capital Business Park were considered as well but none are expected to have any material trips at the subject study intersection. Further, most of the subject background developments are existing (or completed) and or forecast to be captured by the generic corridor growth applied to Hawthorne Road herein. Below are the additional background developments considered, but not expect to impact the study intersections herein.

- 3500 Hawthorne Road – A gas station with convenience store and a fast food restaurant with drive-through.
- 2390 Stevenage Drive – An additional approximately 13,000 m² of industrial use added to the approximately 10,000 m².
- 2480 Walkley Road – Reconfiguration of the existing Giant Tiger.
- The Hydro-Ottawa site at 2711 Hunt Club Road which includes an administration building, an office building, material management building and a PILC building per the Traffic Impact Study by Castleglenn in May 2016.

4.5 Future Background and Total Traffic Volumes

The future background traffic for the study horizons were determined as a sum of the grown existing traffic volumes (per background growth rate) and the traffic generated by the background developments. For consistency, after the projected traffic coming from the site access was assigned to the network, an adjustment was made to through movement traffic such that the volumes on Hawthorne Road between Ages Drive and the site access would match. This was done because the short distance and lack of driveways between the study intersections would preclude any additional traffic entering or leaving the network, suggesting that traffic volumes between the study intersections should be conserved.

The 2026 future background traffic is presented in **Figure 7**.

The total traffic volumes for the study horizons were determined as a sum of the future background traffic volumes and the site generated trips. The 2026 total traffic volumes are presented in **Figure 8**.

4.6 Demand Rationalization

The City's TIA Guidelines notes that if the forecasted traffic demand for an intersection or turning movement exceeds capacity (i.e., volume-to-capacity ratio exceeding 1.00), then future travel demands must be rationalized to account for capacity limitations on the transportation network. Given the forecasted volumes and the operational analysis (within **Section 5.0**), no turning movements exceed capacity under the study horizons. Therefore, demand rationalization is not

required. However, details of the operational measures of effectiveness and recommendations (where required) are presented in **Section 5.0**.

5.0 Analysis

5.1 Development Design

5.1.1. Design for Sustainable Modes

The subject site proposes pedestrian sidewalks around the self-storage building. The sidewalk connects to the paved shoulder on the east side of Hawthorne Road, which is expected to be reconstructed as a 2 m standard sidewalk between the Hawthorne Road / Ages Drive intersection and the site access as part of the development. The sidewalks allow an easy access between the building and the accessible parking, located on the east side of the building.

For all exterior access doors in the proposed development, the walking distance to the closest existing OC Transpo bus stop north of the Hawthorne Road and Ages Drive intersection is less than 250m. Therefore, with 100% of the proposed development being within 400m walking distance to the nearest bus stop, the site permits easy pedestrian access to transit service, consistent with the TIA Guidelines.

Further, the site satisfies the required measures per the Transportation Demand Management (TDM) – Supportive Development Design and infrastructure Checklist. The TDM checklist is included in **Appendix F**.

5.1.2. Circulation and Access

The internal roadway is wide and has adequate radii to support the trucks expected at the site as illustrated on the truck turning diagrams in **Appendix G**. Given the use of development as a self-storage, circulation of the site by a medium single unit truck (MSU) is adequate to account for vehicles such as the waste removal trucks, fire truck and employee vehicles are expected to be feasible given they are smaller than the design trucks.

5.2 Parking Review

5.2.1. Parking Supply

The site is located in area “C – suburban” and the applicable zoning by-law parking requirements for the proposed development are summarized in **Table 8**. As the existing 3169 Hawthorne Road self-storage buildings and the proposed storage development at 3149 Hawthorne Road on the site are all within walking distance of each other and are proposed to function together, a combined estimation of parking requirements was considered for the site.

Table 8: Parking Summary

Land Use	Gross Floor Area (GFA)	By-Law Parking Rate	Parking Required	Total Parking Required	Parking Supply
Proposed Self-storage	10,842 m ²	0.8 per 100 m ² for the first 5000 m ² GFA, 0.4 per 100 m ² thereafter	63 spaces	83 parking spaces	100 parking spaces
Existing Self-storage	4,813 m ²	0.4 per 100 m ² thereafter	19 spaces		

The vehicle parking supply of 100 spaces for both the proposed and existing self-storages satisfy the City's Zoning By-Law requirement. Additionally, the site provides the required barrier free accessible parking spaces and loading spaces. Further, the site provides 12 bicycle parking spaces for the proposed development, in conformance with the By-Law requirement of 1 per 1000 m² of GFA.

5.3 Boundary Street Design

Hawthorne Road is the only boundary street to the proposed development. As noted under **Section 3.1**, the roadway is a truck route with a posted speed limit of 70km/h and has two travel lanes in each direction (including a 3.6m curb lane width). It is assumed that the Motor Vehicle Traffic Volume along Hawthorne Road (AADT) is above 3000 vehicles per day. Hawthorne Road is a designated spinal bike route with on-street bike lanes (~2 m) on either side of the roadway. Further, there is a standard 2 m sidewalk on the west side of a street, with no separation from roadway. A narrow paved shoulder exists on the east side of the roadway near the subject site.

Table 9 highlights the existing Multi-Modal Levels of Service (MMLOS), the target minimum desirable MMLOS based on the City of Ottawa TIA supplement - MMLOS Guidelines, and the expected MMLOS after full buildout of the development. As the site is in an Urban Employment Area, the target MMLOS are based on an arterial road located within an employment area per Exhibit 22 of the MMLOS guidelines (see **Appendix H** for MMLOS excerpts).

Table 9: MMLOS Summary

Roadway	Horizon	PLOS	BLOS	TkLOS
Hawthorne Road	Existing	F	E	A
	Target	C	C	B

As presented in **Table 9**, the pedestrian level of service (PLOS), bicycle LOS (BLOS) are short of the minimum desired, while the truck LOS (TkLOS) exceeds the MMLOS target. In order to improve the existing MMLOS to the desired, the City may consider Urbanization of Hawthorne Road and reducing the posted speed limit from 70 km/h to 60 km/h. Additionally, it is recommended that a pedestrian 2 m sidewalk on the east side of the street between Ages Drive and the site access be implemented as it will improve pedestrian experience near the subject site. It is assumed that the existing paved shoulder will allow for at least 0.5 m boulevard separation between the sidewalk and the roadway. The target MMLOS outlined in **Table 9** are all expected to be achieved with the identified urbanization elements.

Transit LOS on Hawthorne Road is not included herein as data required for accurate estimate of the ratio of average transit travel speed to posted speed limit is not available. The auto traffic LOS at the study boundary intersections is presented in **Section 5.5**.

5.4 Access Intersection Review

The access to the site is at the existing access located south of the site. The access is existing and is expected to continue to serve the existing site and proposed development without safety issues as highlighted by the collision history in **Section 3.1.8**. The access has a corner clearance of 125m from Ages Drive and 90m from the private access farther south; satisfying the corner clearance (Table 8.8.2) and access spacing (section 8.9.8) requirements of the Transportation Association of Canada (TAC) Geometric Design Guide for Canadian Roads (GDGCR), along with the City of Ottawa Private Approach By-law No. 2003-447 requirement per S25.(1)(m).

The access additionally has a clear throat length exceeding the requirement of 15m as prescribed by City staff. Further, Hawthorne Road is a straight and fairly flat roadway with visibility from the access in excess of the TAC-GDCR requirements. The 5x5m sight triangle area on the northwest corner of the access connection at Hawthorne Road is free of any obstruction (i.e., less than 0.6m landscape), which ensures good sightline visibility at the access.

Additionally, section 25 of the City of Ottawa Private Approach (By-law No. 2003-447) outlines the maximum recommended number of driveways on a roadway based on property frontage. The City Private Approach By-Law indicates that for a frontage between 46 m to 150 m - one two-way private approach and two one-way private approaches or two two-way private approaches are permitted. The subject property has a frontage of approximately 135 m (including the existing access), therefore, the existing single access (to be retained) satisfies the City Private Approach By-Law.

As noted in the City comments concerning the September 2021 TIA Report, should the full-movement site access develop a pattern of collisions, the City may require conversion of the access into a right-in right-out (RIRO) configuration. It is noted that, as identified in **Section 3.1.8**, no collision type exceeds the City's threshold of more than 6 collisions near the site access, and the forecasted future traffic volumes identified in **Section 4.5** are only slightly higher from what was identified under the existing conditions (**Section 3.1.7**). Therefore, it is not expected that a recurring pattern of collisions will develop at or near the site access upon implementation of the proposed development.

Therefore, the existing access (to be retained) is adequate from a safety and operational feasibility perspective.

5.5 Intersection Levels of Service

5.5.1 Existing Intersection Operations

The auto traffic operations at the study intersections were analyzed based on of the projected 2021 existing traffic volumes illustrated in **Figure 3. Table 10** outlines the operational measures of effectiveness at the study intersections under the 2021 existing traffic volumes. The Level of Service (LOS) definitions are illustrated in **Appendix H**. Detailed capacity analysis is included in **Appendix I**.

Table 10: 2021 Existing Traffic Operations Summary

Intersection	Control	Peak Hour	Intersection V/C Ratio	Level of Service ^[1]	Average Delay per Vehicle(s)	V/C Ratio ^[2]	95 th %ile Queues > Storage Length
Hawthorne Road and Ages Drive	Signal	A.M.	0.54	A	7.9 s	0.60 (EBL)	45.9m > 40.0m (EBL)
		P.M.	0.59	A	12.3 s	0.64 (EBL)	50.9m > 40.0m (EBL)
Hawthorne Road and 3169 Hawthorne Road Site Access	Stop Controlled (Minor Street)	A.M.	0.34	B	14.2 s	0.38 (NBT)	None
		P.M.	0.36	B	11.6 s	0.31 (SBT)	None

Notes:

[1] Level of Service – The Level of Service (LOS) of an intersection is based on the intersection volume to capacity ratio as per the City of Ottawa Multi-Modal Levels of Service (MMLoS) Guidelines. The LOS of an unsignalized intersection is based on the worst average approach delay.

[2] V/C Ratio – illustrates the maximum and other lane volume to capacity ratios greater than 0.90.

As presented in **Table 10**, under 2021 existing conditions, the intersection of Hawthorne Road and Ages Drive is forecast to operate below capacity at a Level of Service (LOS) “B” or better during the a.m. and p.m. peak hours. Further, the eastbound left-turn lane currently experiences queuing issues during the a.m. and p.m. peak periods. The intersection of Hawthorne Road and 3169 Hawthorne Road Site Access is forecast to operate below capacity at a Level of Service (LOS) “B” or better during the a.m. and p.m. peak hours.

5.5.2. Future Background Intersection Operations

The auto traffic operations at the study intersections were analyzed based on of the projected 2026 future background traffic volumes illustrated in **Figure 7. Table 11** outlines the operational measures of effectiveness at the study intersections under the 2026 future background scenario.

Table 11: 2026 Future Background Traffic Operations Summary

Intersection	Control	Peak Hour	Intersection V/C Ratio	Level of Service	Average Delay per Vehicle(s)	Lane V/C Ratio ^[2]	95 th %ile Queues > Storage Length
Hawthorne Road and Ages Drive	Signal	A.M.	0.56	A	7.4 s	0.58 (EBL)	None
		P.M.	0.59	A	11.8 s	0.58 (EBL)	44.9m > 40.0m (EBL)
Hawthorne Road and 3169 Hawthorne Road Site Access	Stop Controlled (Minor Street)	A.M.	0.36	B	14.0 s	0.37 (NBT)	None
		P.M.	0.38	B	11.7 s	0.30 (SBT)	None

Notes:

[1] Level of Service – The Level of Service (LOS) of an intersection is based on the intersection volume to capacity ratio as per the City of Ottawa Multi-Modal Levels of Service (MMLoS) Guidelines. The LOS of an unsignalized intersection is based on the worst average approach delay.

[2] V/C Ratio – illustrates the maximum and other lane volume to capacity ratios greater than 0.90.

Similar to the 2021 existing conditions, under the 2026 future background conditions, both the

intersection of Hawthorne Road and Ages Drive along with the intersection of Hawthorne Road and 3169 Hawthorne Road site access is forecast to operate below capacity at a LOS “B” or better during the a.m. and p.m. peak hours. Similar to the existing conditions, 95th percentile queues are expected to exceed the eastbound left-turn storage length during the p.m. peak period.

5.5.3. Future Total Intersection Operations

The auto traffic operations at the study intersections were analyzed based on of the projected 2026 future total traffic volumes illustrated in **Figure 8**. **Table 12** outlines the operational measures of effectiveness at the study intersections under the 2026 future total scenario.

Table 12: 2026 Future Total Traffic Operations Summary

Intersection	Control	Peak Hour	Intersection V/C Ratio	Level of Service	Average Delay per Vehicle(s)	V/C Ratio [2]	95 th %ile Queues > Storage Length ^[2]
Hawthorne Road and Ages Drive	Signal	A.M.	0.56	A	7.4 s	0.58 (EBL)	None
		P.M.	0.59	A	11.8 s	0.58 (EBL)	44.4m > 40.0m (EBL)
Hawthorne Road and 3169 Hawthorne Road Site Access	Stop Controlled (Minor Street)	A.M.	0.36	B	13.7 s	0.37 (NBT)	None
		P.M.	0.38	B	11.7 s	0.30 (SBT)	None

Notes:

[1] Level of Service – The Level of Service (LOS) of an intersection is based on the intersection volume to capacity ratio as per the City of Ottawa Multi-Modal Levels of Service (MMLOS) Guidelines. The LOS of an unsignalized intersection is based on the worst average approach delay.

[2] V/C Ratio – illustrates the maximum and other lane volume to capacity ratios greater than 0.90.

Under the 2026 future total conditions, both the intersection of Hawthorne Road and Ages Drive along with the intersection of Hawthorne Road and site access are forecast to operate below capacity at a LOS “B” or better during the a.m. and p.m. peak hours. These operations are similar to the 2026 future background conditions. The LOS for both intersections is better than the target LOS “D” for the subject intersections per Exhibit 22 of the MMLOS guidelines (see **Appendix H** for MMLOS excerpts).

Similar to the existing conditions and future background conditions, the 95th percentile queues for the eastbound left turn are expected to occasionally exceed the eastbound left-turn storage onto the taper during the p.m. peak period. The development herein does not contribute any trips to the eastbound left turn movement.

5.6 Transit

Table 13 outlines the estimated additional transit ridership on OC Transpo Route 47 or any new transit routes in the area.

Table 13: Proposed Development Transit Trips

Time Period	Trips	
	Inbound	Outbound
A.M. Peak	1	1
P.M. Peak	1	2

Due to the minimal transit trip generation, identifying transit capacity changes is not required to support the proposed development.

6.0 Conclusions and Recommendations

This Transportation Impact Assessment (TIA) has assessed the transportation impacts of the proposed self-storage development at 3149 Hawthorne Road in the City of Ottawa. The analysis contained within this report has resulted in the following key findings:

- Under 2021 existing conditions, both the intersection of Hawthorne Road and Ages Drive along with the intersection of Hawthorne Road and 3169 Hawthorne Road site access is forecast to operate below capacity at a level of service (LOS) "B" or better during the a.m. and p.m. peak hours.
- The proposed self-storage development is projected to generate a total of 15 and 26 person-trips during the weekday a.m. and p.m. peak hours, respectively.
- Under the 2026 future background conditions, both the intersection of Hawthorne Road and Ages Drive along with the intersection of Hawthorne Road and 3169 Hawthorne Road site access is forecast to operate below capacity at a LOS "B" or better during the a.m. and p.m. peak hours.
- Similar to the existing and 2026 future background conditions, under the 2026 future total conditions, the study intersections of Hawthorne Road with Ages Drive and the existing site access are forecast to operate below capacity at a LOS "B" or better during the a.m. and p.m. peak hours. The LOS for both intersections under all study horizons is better than the target LOS "D" desired per the City's Multimodal LOS guidelines.
- Under existing conditions and the study horizons, the 95th percentile queues for the eastbound left turn at the Hawthorne Road and Ages Drive intersection is expected to occasionally exceed the storage onto the taper during the peak hours. The proposed development does not contribute trips to the eastbound left turn movement.
- The proposed site access is projected to operate efficiently and safely without any issues related to sight-lines, corner clearance, access spacing and truck movements. Further, the access is not expected to develop a recurring collision pattern, which supports retaining the current full-moves configuration.
- The combined vehicle parking supply of 100 spaces serving both 3149 and 3169 Hawthorne Road satisfies the City's Zoning By-Law requirement for the site. Additionally, the site provides the required barrier free accessible parking spaces and bicycle parking spaces for the combined site. Further, per the City's Zoning By-Law, the loading space requirements for the site are met.

In conclusion, the traffic generated from the proposed Self-storage at 3149 Hawthorne Road is forecast to have an immaterial impact on traffic operations at the boundary intersections. The Site Plan Application can be supported from a traffic operations perspective as the boundary road system is forecast to adequately accommodate the increase in traffic volumes attributable to the proposed development.

Minor changes to the site plan will not materially affect the conclusions contained within this Study. Should you have any questions or require further information, please contact the undersigned.

Respectfully submitted by,

C.F. CROZIER & ASSOCIATES INC.



Peter Apasnore, M.A.Sc., P.Eng., PTOE
Project Manager, Transportation

C.F. CROZER & ASSOCIATES INC.



Aidan Hallsworth, EIT
Engineering Intern, Transportation

/AH

N:\2100\2112- Access Property Dev. Inc\6007- 3149 Hawthorne Rd Self Storage\Reports\3rd Submission\2023.05.18_6007_TIA 3149 Hawthorne.docx

APPENDIX A

Correspondence

From: Dubyk, Wally <Wally.Dubyk@ottawa.ca>
Sent: June 7, 2021 3:11 PM
To: Peter Apasnore <papasnore@cfcrozier.ca>
Subject: RE: Terms of Reference - 3149 Hawthorne Road

Hi Peter,

Update to the TIA Guideline Forecasting Report

- We would like to inform all consultants making TIA Forecasting Report submissions to the City of Ottawa as part of a development application, that all new applications (pre-consultation meetings dated after March 3, 2021) must use the NEW TRANS Trip Generation Manual when forecasting site generated trips using this manual (see attached).
- The TRANS committee (a joint transportation planning committee serving the National Capital region) finalized a new manual early in March 2021. The document will be available in French and English on the TRANS website <http://www.ncr-trans-rcn.ca/surveys/2009-trip-generation>.
- The new manual has simplified the conversion from vehicle trips to person trips and then trips by modal share. The City has also developed a spreadsheet that will apply the factors of location and building type to quickly provide the existing trip numbers by mode share.

Also, the City would prefer the access off the lesser traveled roadway (Acres Drive).

Thank you,

Wally Dubyk
Transportation Project Manager - Transportation Approvals

Development Review, Central & South Branches
Wally.Dubyk@ottawa.ca

From: Peter Apasnore <papasnore@cfcrozier.ca>
Sent: June 07, 2021 2:56 PM
To: Dubyk, Wally <Wally.Dubyk@ottawa.ca>
Subject: Terms of Reference - 3149 Hawthorne Road

CAUTION: This email originated from an External Sender. Please do not click links or open attachments unless you recognize the source.

ATTENTION : Ce courriel provient d'un expéditeur externe. Ne cliquez sur aucun lien et n'ouvrez pas de pièce jointe, excepté si vous connaissez l'expéditeur.

We have been retained to prepare a Transportation Impact Assessment (TIA) for the proposed self-storage at 3149 Hawthorne Road in the City of Ottawa to support a Site Plan Application.

I have included the **screening and scoping steps** as part of this terms of reference which will also be incorporated into the TIA report. Further, given the forecasted low trip generation, I am proposing the TIA scope outlined below. Please provide me your feedback at the earliest possible.

Many Thanks,

The project proposal is detailed in the attached site plan and includes:

- A 4-storey self-storage building (8,278.4 m² GFA)
- A 1-storey records storage building (1,834.2 m² GFA)
- Associated at grade parking and site access through the existing 3169 Hawthorne Road site access

Transportation Impact Assessment (TIA)

The study will be completed in accordance with the City of Ottawa "Transportation Impact Assessment Guidelines (2017)".

- Per the TIA Guideline, the site is expected to **generate 25 and 41 two-way person trips** during the a.m. and p.m. peak hours respectively; **less than the trip generation trigger threshold of 60**. However, the GFA meets the trip generation trigger of 5,000 m².
- Given the low trip generation, analyses of the intersections listed below during the a.m. and p.m. peak hours is adequate for the site.
 - Hawthorne Road and Ages Drive

- Hawthorne Road and the existing 3169 Hawthorne Road Site Access
- The traffic data (turning movement counts, signal timing plans, collision data etc.) will be obtained from the City if available; else existing counts will be undertaken. **If existing counts are undertaken please advise if the City recommends any adjustment to account for Covid-19 impact.**
- Given the size of the development, it is expected that analysis of the existing 2021 and five years after (2026) should adequately capture the developments impacts.
- The growth rates and background development traffic on for Hawthorne Road will be obtained from the Master TIA Study for the National Capital Business Park (dated May 2020 & prepared by NOVATECH). No growth rates or background developments will be applied to Ages Street.
- Forecast the proposed development trips and assign to the boundary road network as follows:
 - Multi-modal person-trips will be determined using the Institute of Transportation Engineers' (ITE - 10th edition) and applying the conversion factor of 1.28 as noted in the City's TIA Guidelines.
 - Auto-trips will be determined using the existing modal share in the area similar to the National Capital Business Park Master TIA study by NOVATECH.
 - Trip assignment to the boundary road network will be based on the existing travel pattern in the area similar, with modification to suit the development herein and site access location.
- Intersection parameters consistent with the City's TIA guidelines and the Site 1 TIA study by NOVATECH will be used. Thus, saturation flow rate: 1800 vphpl, existing conditions PHF: 0.9, future conditions PHF: 1.0 etc. All analyses will be conducted using Synchro (Version 11) modelling software.
- Compare the future background and total traffic operations to identify if capacity issues are forecast to occur per the development proposal herein and recommend mitigation measures as necessary.
- Review the minimum vehicle and bicycle parking requirements for the proposed development per the *City of Ottawa Zoning By-law* and compare with the proposed supply.
- Prepare TIA report to present our findings and recommendations regarding the proposed development.

Peter Apasnore, M.A.Sc., P.Eng., PTOE | Project Engineer
 211 Yonge Street, Suite 301 | Toronto, ON M5B 1M4
 T: 416.477.3392

APPENDIX B

Screening Form

City of Ottawa 2017 TIA Guidelines Screening Form

1. Description of Proposed Development

Municipal Address	3149 Hawthorne Road
Description of Location	Southwest corner of Hawthorne Road & Ages Street
Land Use Classification	Industrial
Development Size (units)	N/A
Development Size (m ²)	10,854
Number of Accesses and Locations	1 - Hawthorne Road
Phase of Development	N/A
Buildout Year	2024 (anticipated)

If available, please attach a sketch of the development or site plan to this form.

2. Trip Generation Trigger

Considering the Development's Land Use type and Size (as filled out in the previous section), please refer to the Trip Generation Trigger checks below.

Land Use Type	Minimum Development Size
Single-family homes	40 units
Townhomes or apartments	90 units
Office	3,500 m ²
Industrial	5,000 m ²
Fast-food restaurant or coffee shop	100 m ²
Destination retail	1,000 m ²
Gas station or convenience market	75 m ²

** If the development has a land use type other than what is presented in the table above, estimates of person-trip generation may be made based on average trip generation characteristics represented in the current edition of the Institute of Transportation Engineers (ITE) Trip Generation Manual.*

If the proposed development size is greater than the sizes identified above, the Trip Generation Trigger is satisfied.

3. Location Triggers

	Yes	No
Does the development propose a new driveway to a boundary street that is designated as part of the City's Transit Priority, Rapid Transit or Spine Bicycle Networks?		✓
Is the development in a Design Priority Area (DPA) or Transit-oriented Development (TOD) zone?*		✓

*DPA and TOD are identified in the City of Ottawa Official Plan (DPA in Section 2.5.1 and Schedules A and B; TOD in Annex 6). See Chapter 4 for a list of City of Ottawa Planning and Engineering documents that support the completion of TIA).

If any of the above questions were answered with 'Yes,' the Location Trigger is satisfied.

4. Safety Triggers

	Yes	No
Are posted speed limits on a boundary street are 80 km/hr or greater?		✓
Are there any horizontal/vertical curvatures on a boundary street limits sight lines at a proposed driveway?		✓
Is the proposed driveway within the area of influence of an adjacent traffic signal or roundabout (i.e. within 300 m of intersection in rural conditions, or within 150 m of intersection in urban/ suburban conditions)?	✓	
Is the proposed driveway within auxiliary lanes of an intersection?		✓
Does the proposed driveway make use of an existing median break that serves an existing site?		✓
Is there is a documented history of traffic operations or safety concerns on the boundary streets within 500 m of the development?		✓
Does the development include a drive-thru facility?		✓

If any of the above questions were answered with 'Yes,' the Safety Trigger is satisfied.

5. Summary

	Yes	No
Does the development satisfy the Trip Generation Trigger?	✓	
Does the development satisfy the Location Trigger?		✓
Does the development satisfy the Safety Trigger?	✓	

If none of the triggers are satisfied, the TIA Study is complete. If one or more of the triggers is satisfied, the TIA Study must continue into the next stage (Screening and Scoping).

APPENDIX C

Municipal and External Report Excerpts

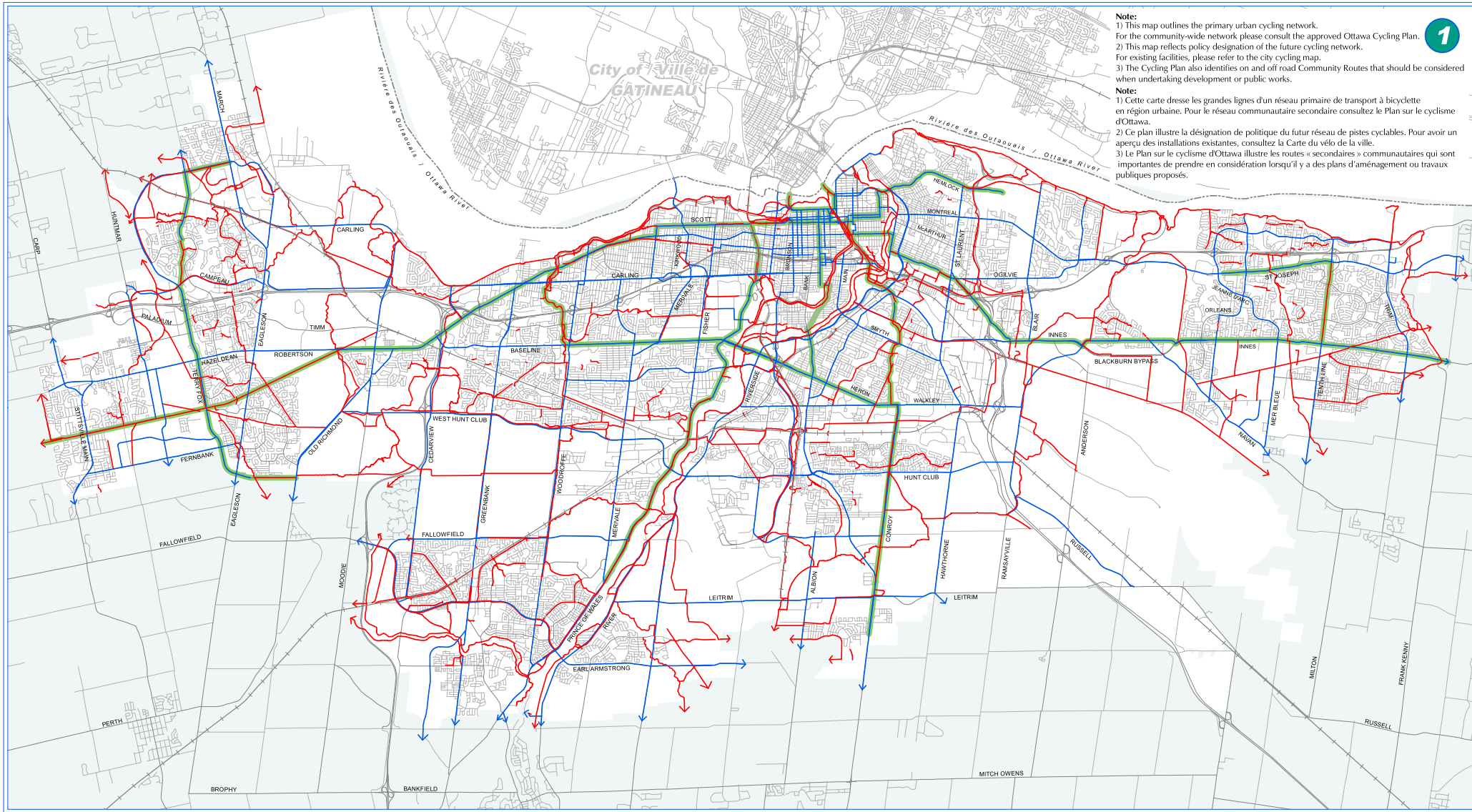

Note:

- 1) This map outlines the primary urban cycling network. For the community-wide network please consult the approved Ottawa Cycling Plan.
- 2) This map reflects policy designation of the future cycling network. For existing facilities, please refer to the city cycling map.
- 3) The Cycling Plan also identifies on and off road Community Routes that should be considered when undertaking development or public works.

Note:

- 1) Cette carte dresse les grandes lignes d'un réseau primaire de transport à bicyclette en région urbaine. Pour le réseau communautaire secondaire consultez le Plan sur le cyclisme d'Ottawa.
- 2) Ce plan illustre la désignation de politique du futur réseau de pistes cyclables. Pour avoir un aperçu des installations existantes, consultez la Carte du vélo de la ville.
- 3) Le Plan sur le cyclisme d'Ottawa illustre les routes « secondaires » communautaires qui sont importantes de prendre en considération lorsqu'il y a des plans d'aménagement ou travaux publics proposés.

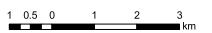

Prepared by: Planning and Growth Management Department,
Mapping & Graphics Unit, 2013
Préparé par: Service de l'urbanisme et de la gestion de la croissance, Unité de la cartographie et des graphiques, 2013

PRIMARY NETWORK	RÉSEAU PRINCIPAL
Spine Route ————	Circuit principal ————
Major Pathway ————	Sentier principal ————
Cross-town Bikeway ————	Voie cyclable transurbaine ————

TRANSPORTATION MASTER PLAN - Map 1
CYCLING NETWORK - PRIMARY URBAN
 PLAN DIRECTEUR DES TRANSPORTS - Carte 1
PLAN DU RÉSEAU URBAIN
DE PISTES CYCLABLES PRINCIPALES

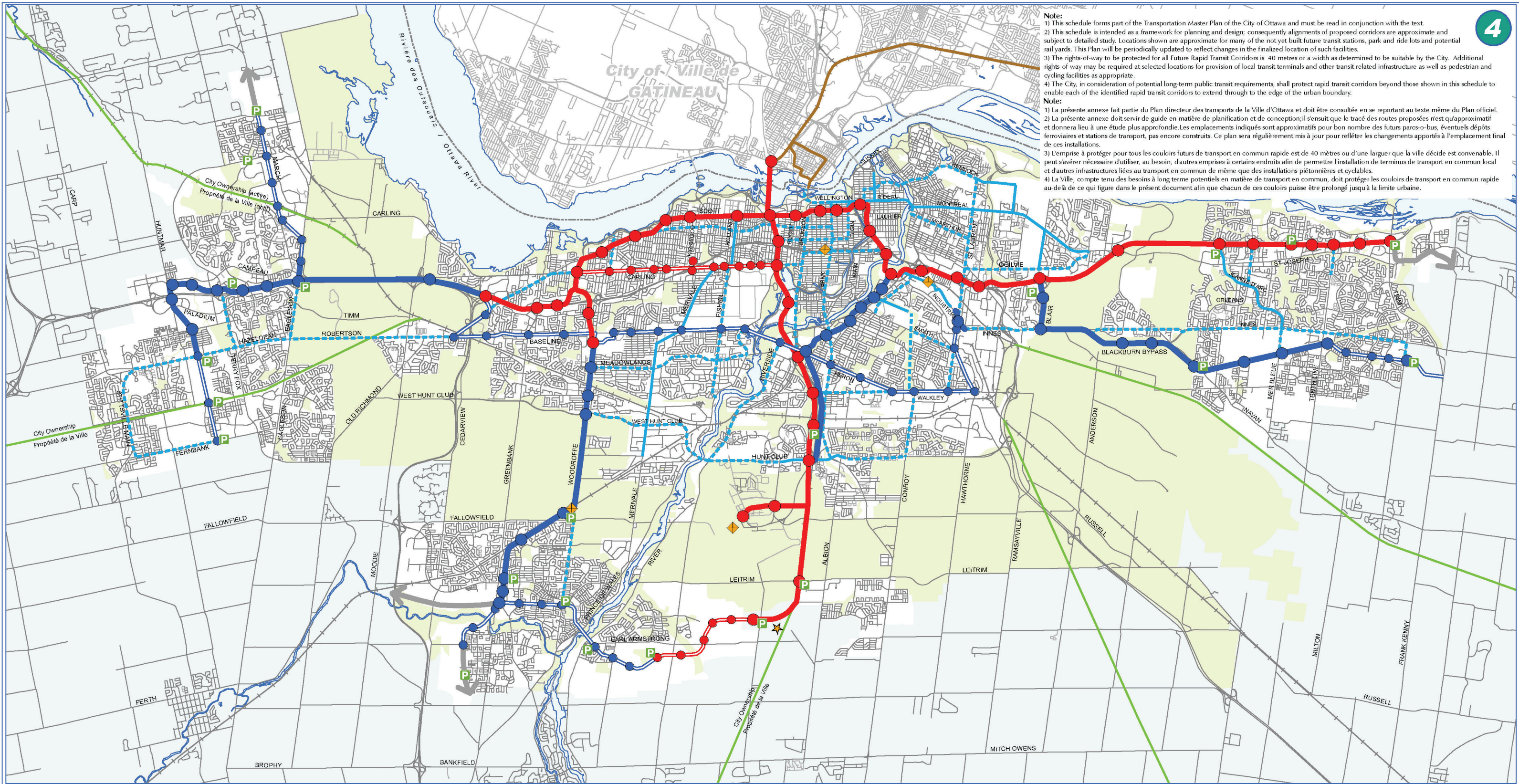

Note:
 1) This schedule forms part of the Transportation Master Plan of the City of Ottawa and must be read in conjunction with the text.
 2) This schedule is intended as a framework for planning and design, consequently alignments of proposed corridors are approximate and subject to detailed study. Locations shown are approximate for many of the not yet built future transit stations, park and ride lots and potential rail yards. This Plan will be periodically updated to reflect changes in the finalized location of such facilities.
 3) The rights-of-way to be protected for all Future Rapid Transit Corridors is 40 metres or a width as determined to be suitable by the City. Additional rights-of-way may be required at selected locations for provision of local transit terminals and other transit related infrastructure as well as pedestrian and cycling facilities as appropriate.
 4) The City, in consideration of potential long-term public transit requirements, shall protect rapid transit corridors beyond those shown in this schedule to enable each of the identified rapid transit corridors to extend through to the edge of the urban boundary.

Note:
 1) La présente annexe fait partie du Plan directeur des transports de la Ville d'Ottawa et doit être consultée en se reportant au texte même du Plan officiel. Il peut s'avérer nécessaire d'utiliser, au besoin, d'autres emprises à certains endroits afin de permettre l'installation de terminus de transport en commun local et d'autres infrastructures liées au transport en commun de même que des installations piétonnières et cyclables.
 2) La présente annexe doit servir de guide en matière de planification et de conception; il s'ensuit que le tracé des routes proposées n'est qu'approximatif et donnera lieu à une étude plus approfondie. Les emplacements indiqués sont approximatifs pour bon nombre des futurs parcs-o-bus, éventuels dépôts ferroviaires et stations de transport, pas encore construits. Ce plan sera régulièrement mis à jour pour refléter les changements apportés à l'emplacement final de ces installations.
 3) L'emprise à protéger pour tous les couloirs futurs de transport en commun rapide est de 40 mètres ou d'une largeur que la ville décide est convenable. Il peut s'avérer nécessaire d'utiliser, au besoin, d'autres emprises à certains endroits afin de permettre l'installation de terminus de transport en commun local et d'autres infrastructures liées au transport en commun de même que des installations piétonnières et cyclables.
 4) La Ville, compte tenu des besoins à long terme potentiels en matière de transport en commun, doit protéger les couloirs de transport en commun rapide au-delà de ce qui figure dans le présent document afin que chacun de ces couloirs puisse être prolongé jusqu'à la limite urbaine.

<p>Prepared by: Planning and Growth Management Department, Mapping & Graphics Unit, 2015 Préparé par: Service de l'urbanisme et de la gestion de la croissance, Unité de la cartographie et des graphiques, 2015</p>	<p>RAPID TRANSIT</p> <p>Light Rail Transit (LRT) - Grade Separated Crossings</p> <p>Light Rail Transit (LRT) - At-Grade Crossings</p> <p>Bus Rapid Transit (BRT) - Grade Separated Crossings</p> <p>Bus Rapid Transit (BRT) - At-Grade Crossings</p>	<p>TRANSPORT EN COMMUN RAPIDE</p> <p>Transport en commun par train léger (TCTL) - passages étagés</p> <p>Transport en commun par train léger (TCTL) - passages à niveau</p> <p>Transport en commun rapide par autobus (TCRA) - passages étagés</p> <p>Transport en commun rapide par autobus (TCRA) - passages à niveau</p>	<p>Park and Ride</p> <p>Transit Station - rail</p> <p>Transit Station - bus</p> <p>Conceptual Future Transit Corridor</p> <p>Abandoned Railway Corridor</p> <p>Inter-regional Stations</p> <p>Potential Rail Yard</p> <p>Gatineau Rapibus</p>	<p>TRANSIT PRIORITY</p> <p>Transit Priority Corridor (Continuous Lanes)</p> <p>Transit Priority Corridor (Isolated Measures)</p>	<p>PRIORITÉ AU TRANSPORT EN COMMUN</p> <p>Corridor donnant priorité au transport en commun (voies continues)</p> <p>Corridor donnant priorité au transport en commun (mesures isolées)</p>	<p>Parc-O-Bus</p> <p>Station du transport - train</p> <p>Station du transport - autobus</p> <p>Avenir conceptuel - Couloir de transport en commun</p> <p>Emprises ferroviaires abandonnées</p> <p>Stations interrégionales</p> <p>Cour de tirage possible pour trains</p> <p>Rapibus de Gatineau</p>	<p>TRANSPORTATION MASTER PLAN - Map 4</p> <p>RAPID TRANSIT AND</p> <p>TRANSIT PRIORITY NETWORK</p> <p>- 2031 NETWORK CONCEPT</p> <p>PLAN DIRECTEUR DES TRANSPORTS - Carte 4</p> <p>RÉSEAU DE TRANSPORT EN COMMUN RAPIDE</p> <p>ET DE TRANSPORT EN COMMUN PRIORITAIRE</p> <p>- CONCEPT DU RÉSEAU 2031</p>
---	---	--	---	---	---	---	--

Urban Truck Routes Parcours pour camions - Secteur urbain



1 March 2017
1 mars 2017

Legend / Légende

- Full Loads / Charges maximales (Red dashed line)
- Restricted Loads / Charges limitées (Purple dashed line)
- Provincial Highways / Routes provinciales (Black solid line)

0 200 400 600 800 1000 m

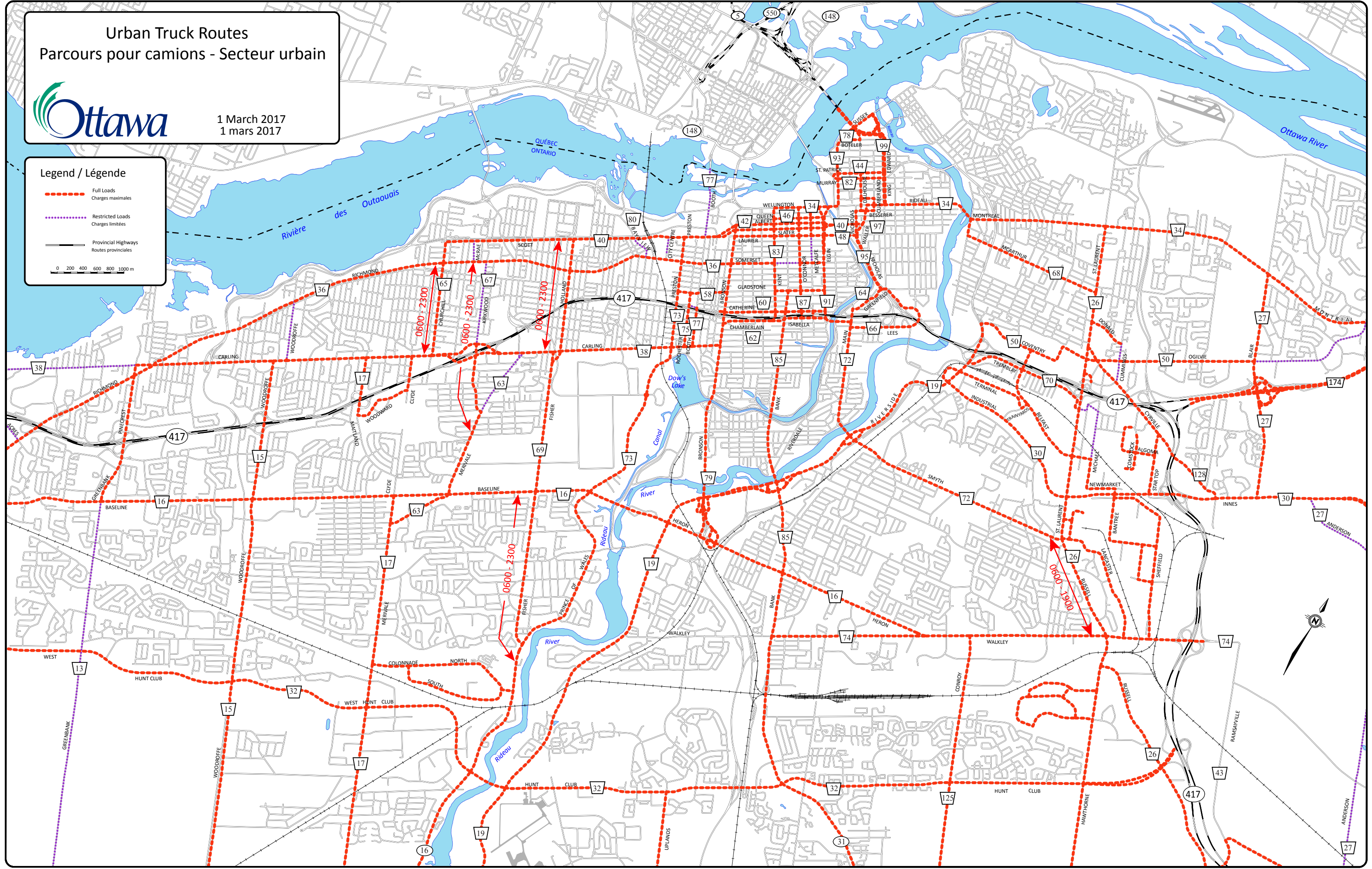



47

HAWTHORNE ST-LAURENT

Local

Monday to Friday / Lundi au vendredi
Peak periods only
Périodes de pointe seulement

PM
↑
ST-LAURENT

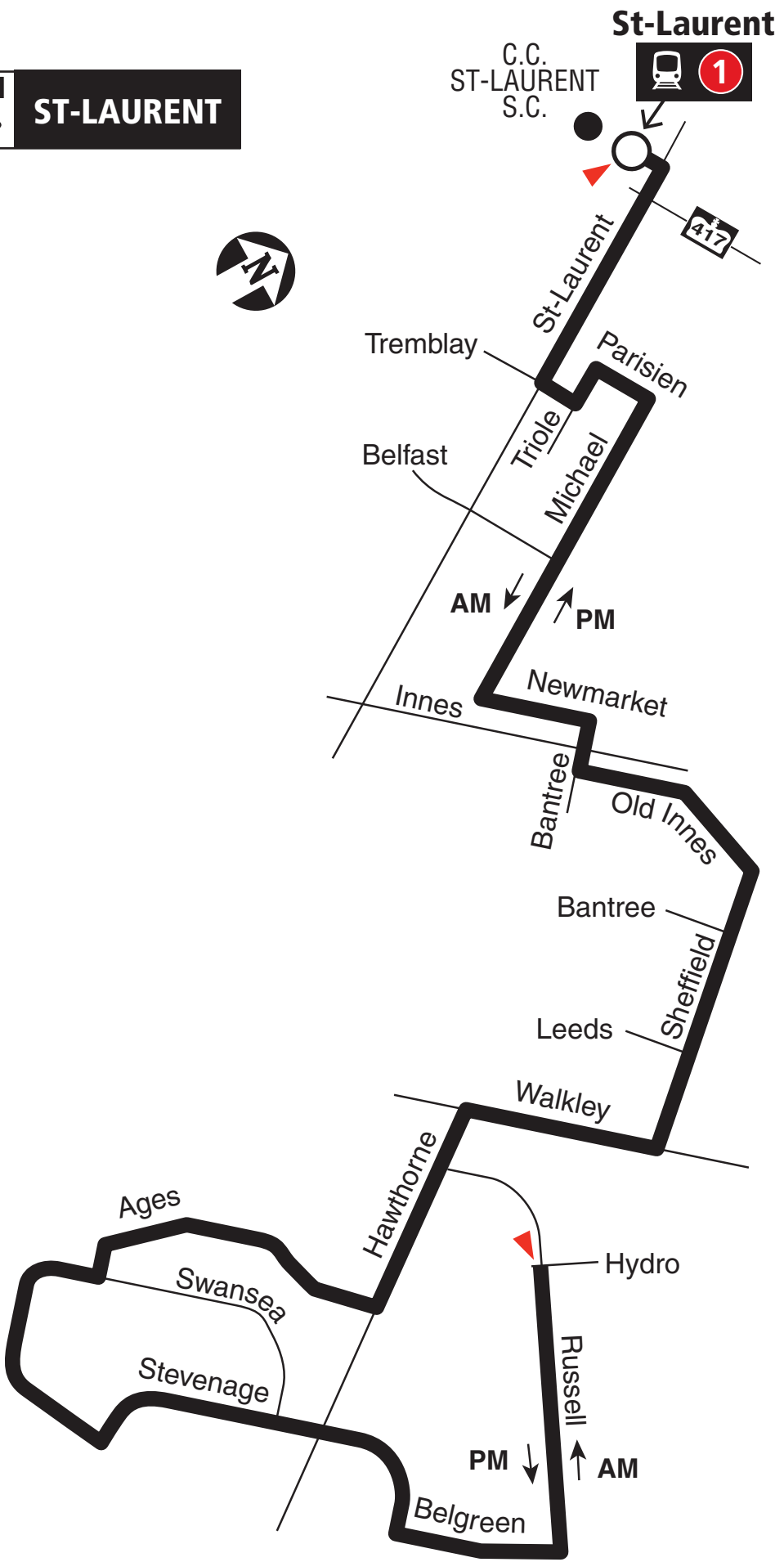

AM
↓
HAWTHORNE



Station



Timepoint / Heures de passage

2019.06

Schedule / Horaire 613-560-1000

Text / Texto 560560

plus your four digit bus stop number / plus votre numéro d'arrêt à quatre chiffres

Customer Service

Service à la clientèle **613-741-4390**

Lost and Found / Objets perdus..... **613-563-4011**

Security / Sécurité **613-741-2478**

Effective June 25, 2017

En vigueur 25 juin 2017



INFO 613-741-4390
octranspo.com



47

HAWTHORNE ST-LAURENT

Local

Monday to Friday / Lundi au vendredi
Peak periods only
Périodes de pointe seulement

PM
↑
ST-LAURENT

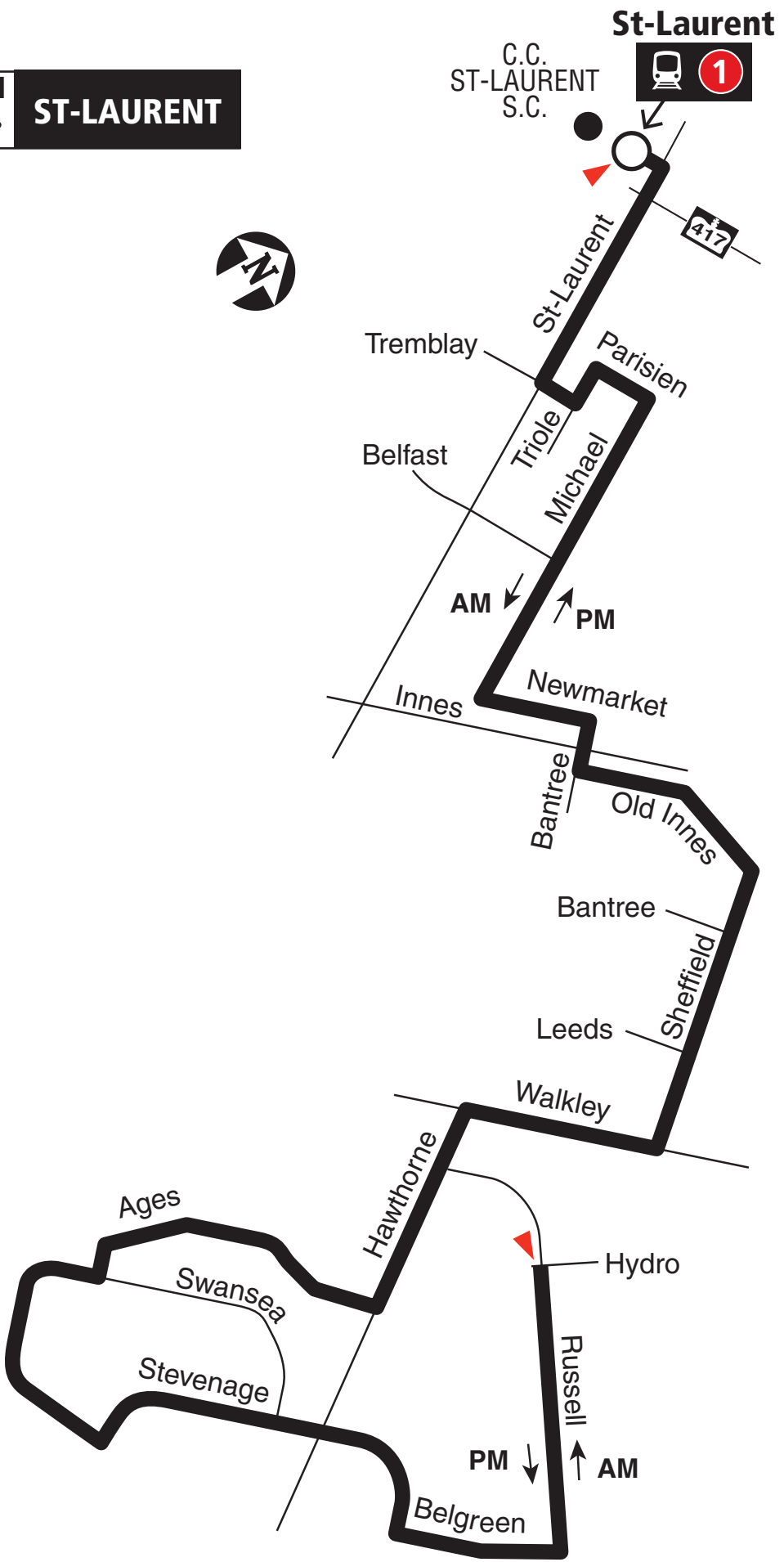

AM
↓
HAWTHORNE



Station



Timepoint / Heures de passage

2019.06

Schedule / Horaire 613-560-1000

Text / Texto 560560

plus your four digit bus stop number / plus votre numéro d'arrêt à quatre chiffres

Customer Service

Service à la clientèle **613-741-4390**

Lost and Found / Objets perdus..... **613-563-4011**

Security / Sécurité **613-741-2478**

Effective June 25, 2017

En vigueur 25 juin 2017



INFO 613-741-4390
octranspo.com

Engineering

- Land / Site Development
- Municipal Infrastructure
- Environmental / Water Resources
- Traffic / Transportation
- Structural
- Recreational

Planning

- Land / Site Development
- Planning Application Management
- Municipal Planning Documents & Studies
- Expert Witness (OMB)
- Wireless Industry

Landscape Architecture

- Urban Design & Streetscapes
- Open Space, Parks & Recreation Planning
- Community & Residential Developments
- Commercial & Institutional Sites
- Environmental Restoration



National Capital Business Park

Traffic Impact Assessment

National Capital Business Park
4055 and 4120 Russell Road
Transportation Impact Assessment

Prepared By:

NOVATECH
Suite 200, 240 Michael Cowpland Drive
Ottawa, Ontario
K2M 1P6

May 2020

Novatech File: 119124
Ref: R-2020-015

5.0 Forecasting

5.1 Development-Generated Traffic

5.1.1 Trip Generation

The proposed development is planned to be completed with three subareas consisting of:

- Site 1- one warehouse with 8,325m² (89,610ft²);
- Site 2- two warehouses with 17,400m² (187,300ft²); and,
- Site 3- three warehouses with 75,685m² (814,700ft²).

Trips generated by the proposed site development were estimated using *Trip Generation, 10th Edition* (Institute of Transportation Engineers, Washington, 2017). Person trips were estimated (See **Table 3**) using an ITE Trip to Person Trip conversion factor of 1.28, consistent with the City of Ottawa TIA Guidelines.

Table 3: Person Trip Generation

Land Use ¹	Units ²	Person Trips Generated ³					
		AM Peak Hour			PM Peak Hour		
		In	Out	Total	In	Out	Total
Site 1							
Warehouse (ITE 150)	89.6	35	11	46	13	36	49
Site 2							
Warehouse (ITE 150)	187.3	47	14	61	17	47	64
Site 3							
Warehouse (ITE 150)	120.2	39	12	51	15	39	54
High-Cube Parcel Hub Warehouse (ITE 156)	694.5	470	469	939	631	297	928
Total Development Trip Generation Sites 1-3		591	506	1097	676	419	1095
Notes: 1. Trip Generation for the associated Land Use from <i>Trip Generation 10th Edition</i> (Institute of Transportation Engineers, Washington, 2017). Trips have been increased by 28% to account for 10% non-auto mode share and average vehicle occupancy of 1.15. 2. Units are 1,000 ft ² of GFA. 3. Person trips per hour for peak hours.							

The modal shares for the proposed development are anticipated to be generally consistent with the existing modal shares (See **Table 4**) outlined in the *2011 TRANS O-D Survey Report*, specific to the Hunt Club region which indicate the modal share values for the trips to/from and within the Hunt Club district. An increase to the auto driver share has been applied based on the location of the subject site, as the site is somewhat removed from significant residential development with minimal active transportation connections and transit service. The projected person trips by modal share for this full development are shown in **Table 4**.

Table 4: Person Trips by Modal Share

Travel Mode	Existing Modal Share	Target Modal Share	AM Peak			PM Peak		
			IN	OUT	TOT	IN	OUT	TOT
Site 1								
Person Trips			35	11	46	13	36	49
Auto Driver	60%	70%	24	7	31	9	25	34
Auto Passenger	15%	15%	5	2	7	2	5	7
Transit	15%	10%	4	1	5	1	4	5
Active Trips	10%	5%	2	1	3	1	2	3
Site 2								
Person Trips			47	14	61	17	47	64
Auto Driver	60%	70%	33	10	43	11	33	44
Auto Passenger	15%	15%	7	2	9	3	7	10
Transit	15%	10%	5	1	6	2	5	7
Active Trips	10%	5%	2	1	3	1	2	3
Site 3								
Person Trips			509	481	990	646	336	982
Auto Driver	60%	70%	357	337	694	452	235	687
Auto Passenger	15%	15%	76	72	148	97	50	147
Transit	15%	10%	51	48	99	65	34	99
Active Trips	10%	5%	25	24	49	32	17	49
Total Development								
Person Trips			591	506	1097	676	419	1095
Auto Driver	60%	70%	414	354	768	472	293	765
Auto Passenger	15%	15%	88	76	164	102	62	164
Transit	15%	10%	60	50	110	68	43	111
Active Trips	10%	5%	29	26	55	34	21	55

Full Buildout of the proposed development is estimated to generate 768 two-way vehicle trips during the AM peak hour and 765 two-way vehicle trips during the PM peak hour.

5.1.2 Trip Distribution / Assignment

The overall distribution of trips generated by the development has been estimated (see below) based on the observed volumes along the study area roadways as well as a review of the existing settlement patterns.

- 10% to/from the north via Russell Road (Alta Vista)
- 10% to/from the south / east (Russell Road south, Hwy 417 E)
- 5% to/from the south (East Barrhaven and Airport via Ramsayville Road)
- 40% to/from the north/west (Hwy 417 W)
- 15% to/from the west via Walkley Road (Alta Vista, Baseline Road)
- 20% to/from the west via Hunt Club (Nepean)

Trips have been assigned based on the assumptions presented in **Table 5**.

Table 5: Trip Assignment Assumptions

	Buildings A & B	Buildings D & E	Buildings C & F
Trip Breakdown	The parcel hub (Building A) accounts for ~95% of all the Site 3 trips	These buildings account for all the Site 2 trips	Building F is ~1% of all Site 3 trips Building C is all the Site 1 trips
Hwy 417^{1,2}	50% of trips will use the Hunt Club interchange and the Street 1 connection to Hunt Club	100% of trips will use the Hunt Club interchange and the Street 1 connection to Hunt Club	80% of trips will use the Hunt Club interchange and the Street 1 connection to Hunt Club
Hunt Club W	50% of trips will use the Street 1 connection to Hunt Club, remainder will use Hawthorne to Russell	100% of trips will use the Street 1 connection to Hunt Club	100% of trips will use the Street 1 connection to Hunt Club
To / from north on Russell	70% of trips will use the north driveway	100% of trips will use the north driveway	60% of trips will use the north driveway
To / from south on Russell	30% of trips will use the north driveway	100% of trips will use the north driveway	20% of trips will use the north driveway

Notes: 1. All Highway 417 trips from and to the west not assigned to the Hunt Club Street 1 connection were assigned to the Walkley Road interchange.

Notes: 2. All Highway 417 trips from and to the east not assigned to the Hunt Club Street 1 connection were assigned to the Anderson Road interchange.

Site generated traffic volumes for the three sub area sites have been assigned to the study area intersections and are shown in **Figure 5**.

Figure 5: Site Generated Traffic Volumes

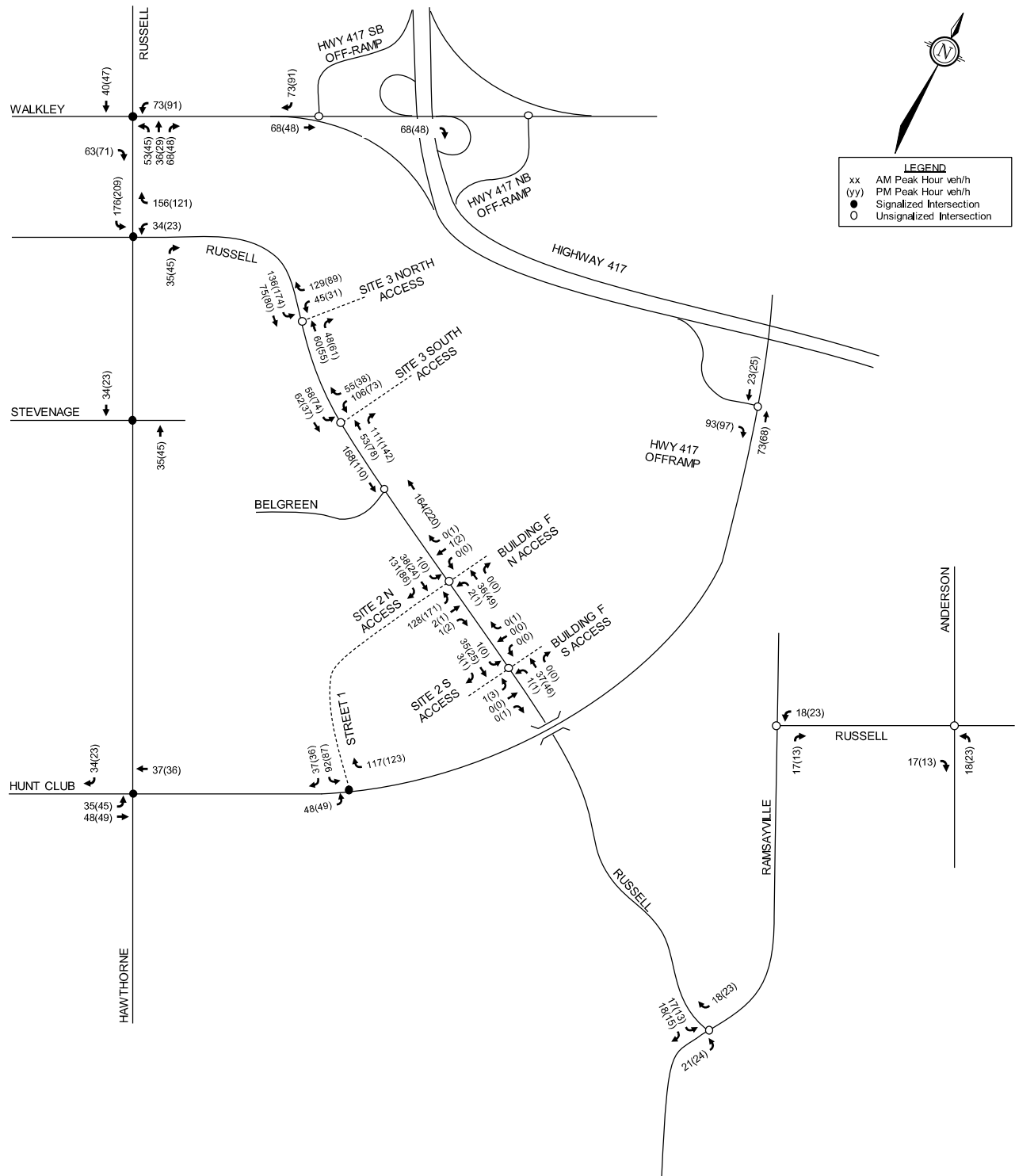

APPENDIX D

Turning Movement Counts

Survey Date: Wednesday, January 25, 2017

WO No: 36659

Start Time: 07:00

Device: Miovision

Full Study Diagram

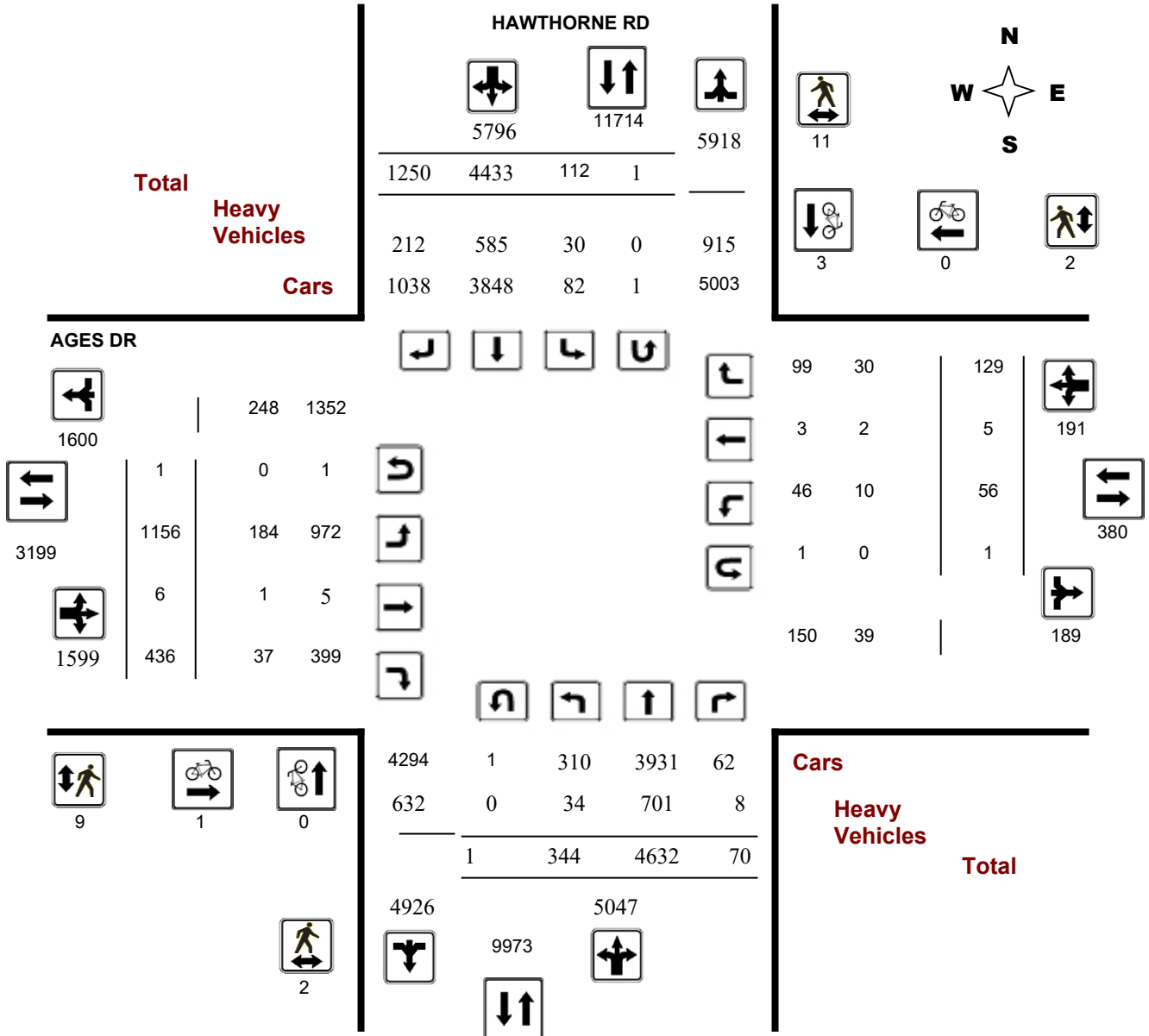

Turning Movement Count - Study Results

AGES DR @ HAWTHORNE RD

Survey Date: Wednesday, January 25, 2017

WO No: 36659

Start Time: 07:00

Device: Miovision

Full Study Peak Hour Diagram

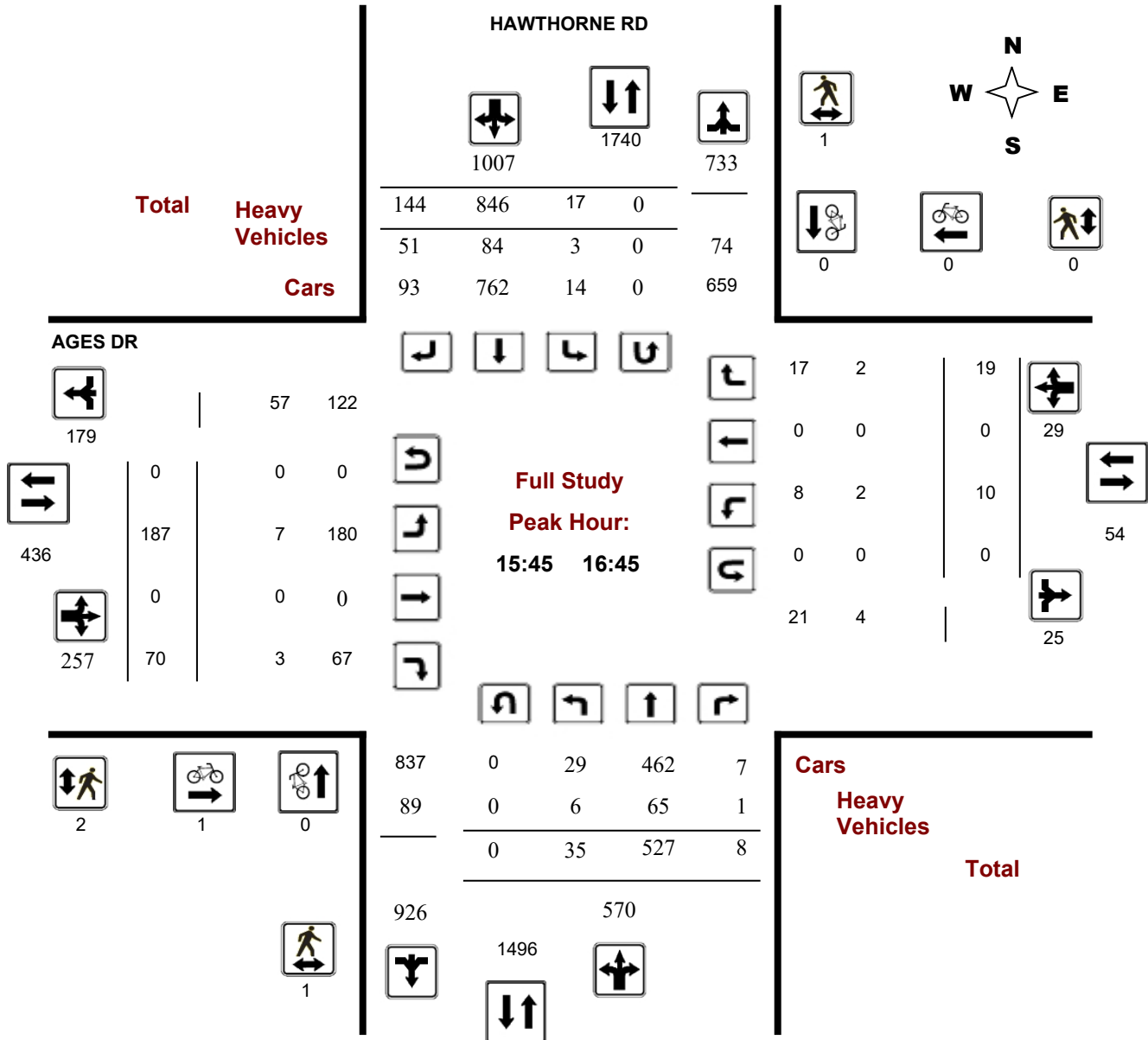

Turning Movement Count - Peak Hour Diagram

AGES DR @ HAWTHORNE RD

Survey Date: Wednesday, January 25, 2017

Start Time: 07:00

WO No: 36659

Device: Miovision

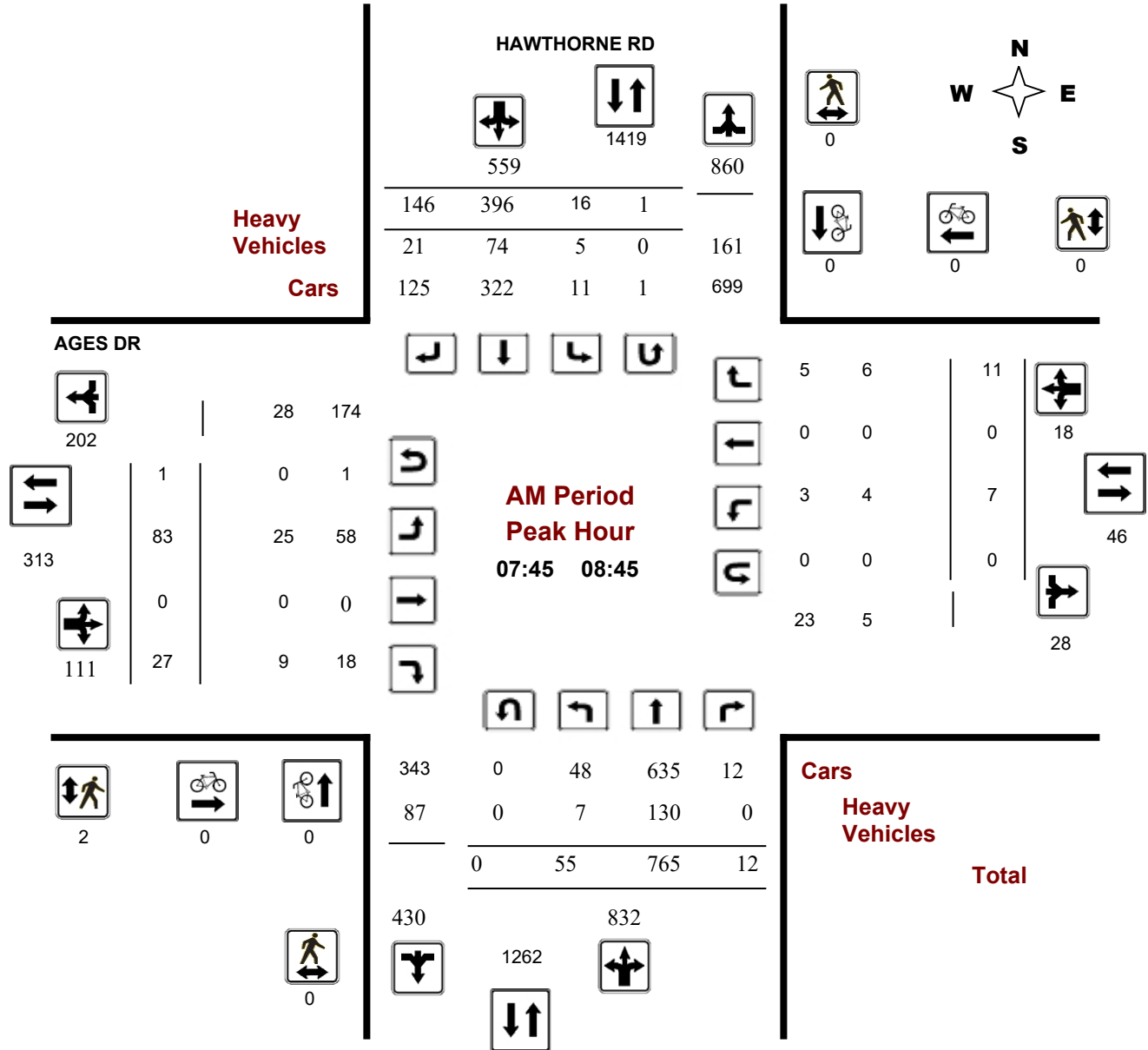

Turning Movement Count - Peak Hour Diagram

AGES DR @ HAWTHORNE RD

Survey Date: Wednesday, January 25, 2017

Start Time: 07:00

WO No: 36659

Device: Miovision

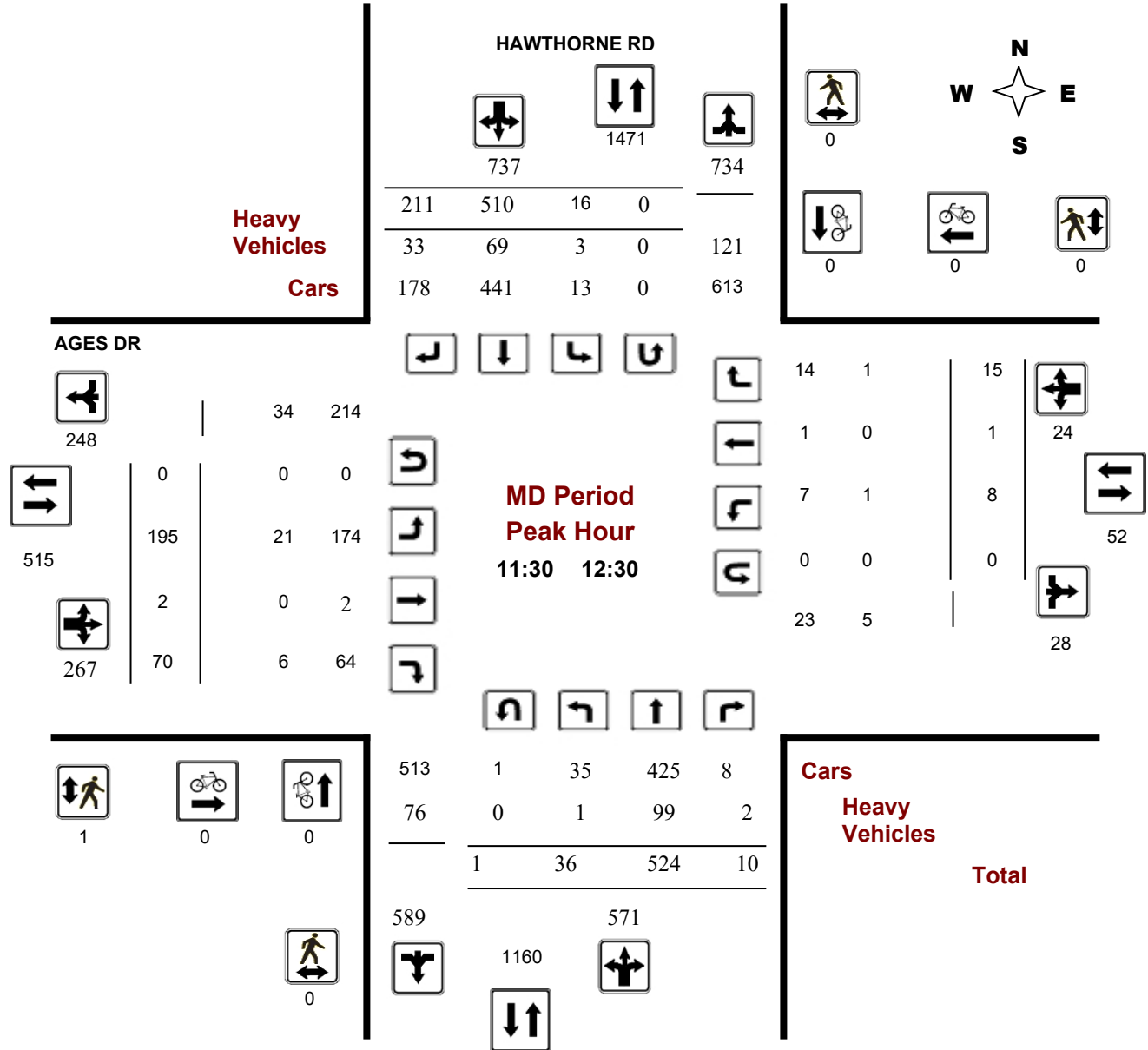

Turning Movement Count - Peak Hour Diagram

AGES DR @ HAWTHORNE RD

Survey Date: Wednesday, January 25, 2017

Start Time: 07:00

WO No: 36659

Device: Miovision

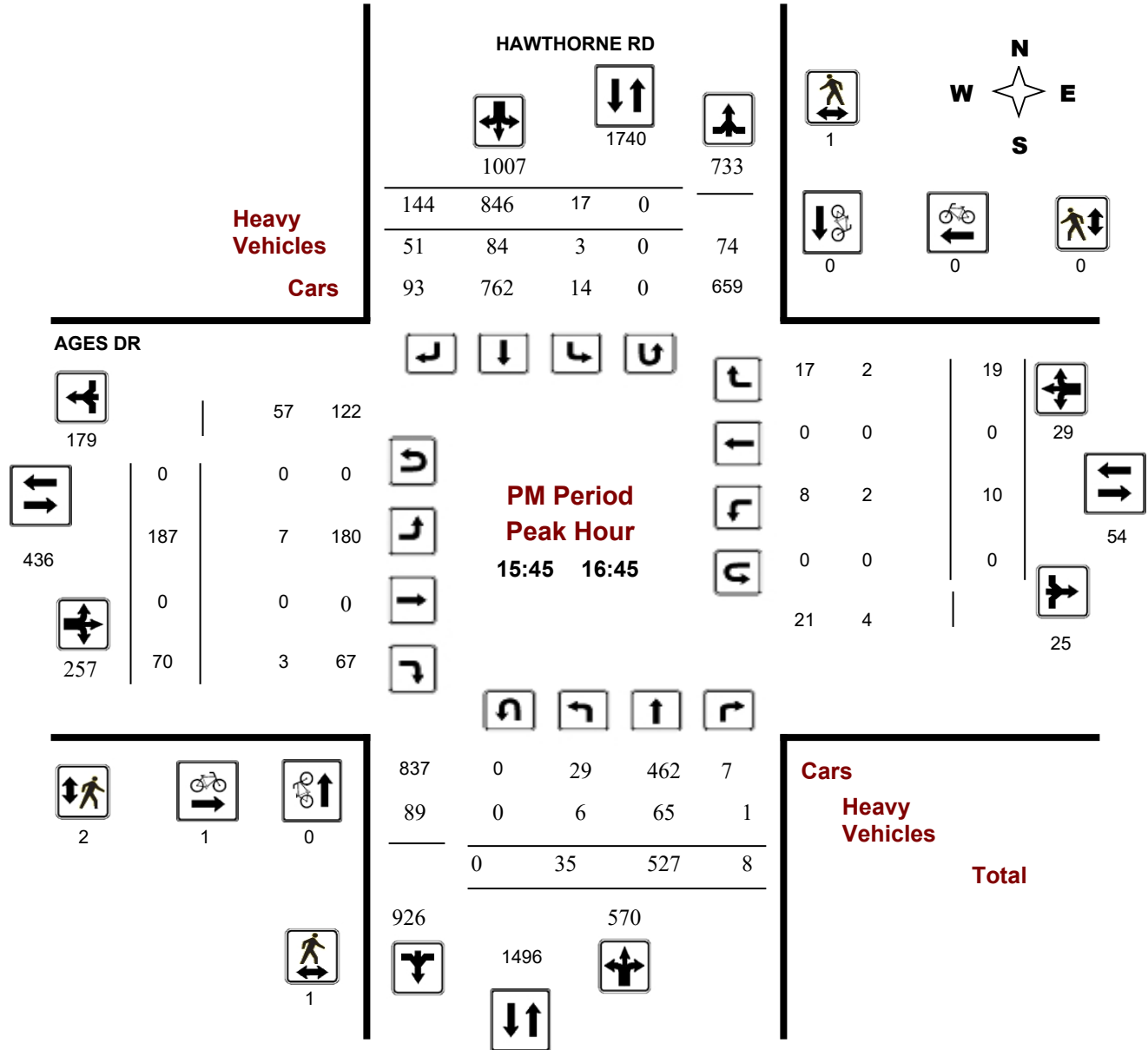



Transportation Services - Traffic Services

Turning Movement Count - Study Results

AGES DR @ HAWTHORNE RD

Survey Date: Wednesday, January 25, 2017

WO No: 36659

Start Time: 07:00

Device: Miovision

Full Study Summary (8 HR Standard)

Survey Date: Wednesday, January 25, 2017

Total Observed U-Turns

AADT Factor

Northbound: 1 Southbound: 1

1.00

Eastbound: 1 Westbound: 1

Period	HAWTHORNE RD									AGES DR									Grand Total
	Northbound			NB TOT	Southbound			SB TOT	STR TOT	Eastbound			EB TOT	Westbound			WB TOT	STR TOT	
	LT	ST	RT		LT	ST	RT			LT	ST	RT		LT	ST	RT			
07:00 08:00	42	693	18	753	19	392	177	588	1341	106	0	15	121	2	2	15	19	140	1481
08:00 09:00	50	747	8	805	14	412	118	544	1349	97	1	33	131	5	1	12	18	149	1498
09:00 10:00	47	638	12	697	13	403	176	592	1289	100	0	42	142	7	1	13	21	163	1452
11:30 12:30	36	524	10	570	16	510	211	737	1307	195	2	70	267	8	1	15	24	291	1598
12:30 13:30	56	502	7	565	23	496	187	706	1271	172	1	69	242	7	0	20	27	269	1540
15:00 16:00	40	543	6	589	12	734	161	907	1496	170	0	66	236	5	0	19	24	260	1756
16:00 17:00	34	524	6	564	13	826	127	966	1530	186	2	71	259	12	0	21	33	292	1822
17:00 18:00	39	461	3	503	2	660	93	755	1258	130	0	70	200	10	0	14	24	224	1482
Sub Total	344	4632	70	5046	112	4433	1250	5795	10841	1156	6	436	1598	56	5	129	190	1788	12629
U Turns	1			1	1			1	2	1			1	1			1	2	4
Total	345	4632	70	5047	113	4433	1250	5796	10843	1157	6	436	1599	57	5	129	191	1790	12633
EQ 12Hr	480	6438	97	7015	157	6162	1737	8056	15071	1608	8	606	2222	79	7	179	265	2487	17558
Note: These values are calculated by multiplying the totals by the appropriate expansion factor.													1.39						
AVG 12Hr	480	6438	97	7015	157	6162	1737	8056	15071	1608	8	606	2222	79	7	179	265	2487	17558
Note: These volumes are calculated by multiplying the Equivalent 12 hr. totals by the AADT factor.													1.00						
AVG 24Hr	629	8434	127	9190	206	8072	2275	10553	19743	2106	10	794	2910	103	9	234	346	3256	22999
Note: These volumes are calculated by multiplying the Average Daily 12 hr. totals by 12 to 24 expansion factor.													1.31						
Note: U-Turns provided for approach totals. Refer to 'U-Turn' Report for specific breakdown.																			



Transportation Services - Traffic Services

Turning Movement Count - Study Results

AGES DR @ HAWTHORNE RD

Survey Date: Wednesday, January 25, 2017

WO No: 36659

Start Time: 07:00

Device: Miovision

Full Study 15 Minute Increments

HAWTHORNE RD

AGES DR

Northbound

Southbound

Eastbound

Westbound

Time Period	LT	ST	RT	N TOT	LT	ST	RT	S TOT	STR TOT	LT	ST	RT	E TOT	LT	ST	RT	W TOT	STR TOT	Grand Total
07:00 07:15	9	140	1	150	4	106	43	153	303	24	0	1	25	0	1	6	7	32	335
07:15 07:30	8	169	7	184	7	90	49	146	330	35	0	5	40	0	1	0	1	41	371
07:30 07:45	13	176	4	193	3	94	31	128	321	27	0	4	31	0	0	4	4	35	356
07:45 08:00	12	208	6	226	5	102	54	161	387	21	0	5	26	2	0	5	7	33	420
08:00 08:15	7	186	1	194	2	90	31	123	317	13	0	6	19	1	0	1	2	21	338
08:15 08:30	17	181	4	202	7	102	27	136	338	23	0	8	31	4	0	4	8	39	377
08:30 08:45	19	190	1	210	3	102	34	139	349	27	0	8	35	0	0	1	1	36	385
08:45 09:00	7	190	2	199	3	118	26	147	346	34	1	11	46	0	1	6	7	53	399
09:00 09:15	7	153	3	163	3	105	34	142	305	23	0	7	30	0	0	1	1	31	336
09:15 09:30	21	174	2	197	1	94	43	138	335	18	0	9	27	3	0	4	7	34	369
09:30 09:45	8	181	6	195	2	100	46	148	343	32	0	15	47	2	0	3	5	52	395
09:45 10:00	11	130	1	142	7	104	53	164	306	27	0	11	38	2	1	5	8	46	352
11:30 11:45	9	132	2	143	3	108	45	156	299	58	1	18	77	1	0	4	5	82	381
11:45 12:00	10	121	4	135	2	117	71	190	325	46	0	24	70	2	1	1	4	74	399
12:00 12:15	7	132	1	140	4	154	48	206	346	49	1	15	65	4	0	6	10	75	421
12:15 12:30	11	139	3	153	7	131	47	185	338	42	0	13	55	1	0	4	5	60	398
12:30 12:45	14	127	1	142	5	116	44	165	307	42	1	11	54	3	0	7	10	64	371
12:45 13:00	13	121	1	135	3	116	49	168	303	56	0	13	69	3	0	7	10	79	382
13:00 13:15	14	123	2	139	9	123	51	183	322	38	0	23	61	1	0	2	3	64	386
13:15 13:30	15	131	3	149	6	141	43	190	339	36	0	22	58	0	0	4	4	62	401
15:00 15:15	10	146	1	157	3	176	34	213	370	57	0	17	74	0	0	6	6	80	450
15:15 15:30	10	141	2	153	1	154	39	194	347	34	0	15	49	3	0	4	7	56	403
15:30 15:45	11	127	0	138	2	188	41	231	369	47	0	18	65	2	0	4	6	71	440
15:45 16:00	9	129	3	141	6	216	47	269	410	32	0	16	48	1	0	5	6	54	464
16:00 16:15	6	137	0	143	1	234	33	268	411	61	0	25	86	3	0	2	5	91	502
16:15 16:30	13	111	2	126	7	199	31	237	363	38	0	14	52	1	0	7	8	60	423
16:30 16:45	7	150	3	160	3	197	33	233	393	56	0	15	71	5	0	5	10	81	474
16:45 17:00	8	126	1	135	2	196	30	228	363	31	2	17	50	3	0	7	10	60	423
17:00 17:15	12	146	2	160	0	203	31	234	394	52	0	22	74	5	0	6	11	85	479
17:15 17:30	6	116	1	123	0	178	21	199	322	25	0	16	41	2	0	3	5	46	368
17:30 17:45	8	112	0	120	1	143	23	167	287	38	0	20	58	1	0	3	4	62	349
17:45 18:00	13	87	0	100	1	136	18	155	255	15	0	12	27	2	0	2	4	31	286
Total:	345	4632	70	5047	113	4433	1250	5796	10843	1157	6	436	1599	57	5	129	191	10843	12,633

Note: U-Turns are included in Totals.



Transportation Services - Traffic Services

Turning Movement Count - Study Results

AGES DR @ HAWTHORNE RD

Survey Date: Wednesday, January 25, 2017

WO No: 36659

Start Time: 07:00

Device: Miovision

Full Study Cyclist Volume

HAWTHORNE RD

AGES DR

Time Period		Northbound	Southbound	Street Total	Eastbound	Westbound	Street Total	Grand Total
07:00	07:15	0	0	0	0	0	0	0
07:15	07:30	0	0	0	0	0	0	0
07:30	07:45	0	0	0	0	0	0	0
07:45	08:00	0	0	0	0	0	0	0
08:00	08:15	0	0	0	0	0	0	0
08:15	08:30	0	0	0	0	0	0	0
08:30	08:45	0	0	0	0	0	0	0
08:45	09:00	0	0	0	0	0	0	0
09:00	09:15	0	0	0	0	0	0	0
09:15	09:30	0	0	0	0	0	0	0
09:30	09:45	0	0	0	0	0	0	0
09:45	10:00	0	0	0	0	0	0	0
11:30	11:45	0	0	0	0	0	0	0
11:45	12:00	0	0	0	0	0	0	0
12:00	12:15	0	0	0	0	0	0	0
12:15	12:30	0	0	0	0	0	0	0
12:30	12:45	0	0	0	0	0	0	0
12:45	13:00	0	0	0	0	0	0	0
13:00	13:15	0	0	0	0	0	0	0
13:15	13:30	0	0	0	0	0	0	0
15:00	15:15	0	0	0	0	0	0	0
15:15	15:30	0	0	0	0	0	0	0
15:30	15:45	0	0	0	0	0	0	0
15:45	16:00	0	0	0	0	0	0	0
16:00	16:15	0	0	0	0	0	0	0
16:15	16:30	0	0	0	0	0	0	0
16:30	16:45	0	0	0	1	0	1	1
16:45	17:00	0	0	0	0	0	0	0
17:00	17:15	0	1	1	0	0	0	1
17:15	17:30	0	1	1	0	0	0	1
17:30	17:45	0	1	1	0	0	0	1
17:45	18:00	0	0	0	0	0	0	0
Total		0	3	3	1	0	1	4



Transportation Services - Traffic Services

Turning Movement Count - Study Results

AGES DR @ HAWTHORNE RD

Survey Date: Wednesday, January 25, 2017

WO No: 36659

Start Time: 07:00

Device: Miovision

Full Study Pedestrian Volume

HAWTHORNE RD

AGES DR

Time Period	NB Approach (E or W Crossing)	SB Approach (E or W Crossing)	Total	EB Approach (N or S Crossing)	WB Approach (N or S Crossing)	Total	Grand Total
07:00 07:15	0	2	2	0	0	0	2
07:15 07:30	0	2	2	0	1	1	3
07:30 07:45	0	3	3	1	0	1	4
07:45 08:00	0	0	0	1	0	1	1
08:00 08:15	0	0	0	0	0	0	0
08:15 08:30	0	0	0	1	0	1	1
08:30 08:45	0	0	0	0	0	0	0
08:45 09:00	0	0	0	0	0	0	0
09:00 09:15	0	0	0	0	0	0	0
09:15 09:30	0	0	0	0	0	0	0
09:30 09:45	0	0	0	0	0	0	0
09:45 10:00	0	0	0	0	0	0	0
11:30 11:45	0	0	0	0	0	0	0
11:45 12:00	0	0	0	1	0	1	1
12:00 12:15	0	0	0	0	0	0	0
12:15 12:30	0	0	0	0	0	0	0
12:30 12:45	0	0	0	0	1	1	1
12:45 13:00	0	0	0	0	0	0	0
13:00 13:15	0	0	0	1	0	1	1
13:15 13:30	0	0	0	0	0	0	0
15:00 15:15	0	0	0	0	0	0	0
15:15 15:30	0	0	0	2	0	2	2
15:30 15:45	0	0	0	0	0	0	0
15:45 16:00	0	1	1	1	0	1	2
16:00 16:15	1	0	1	0	0	0	1
16:15 16:30	0	0	0	1	0	1	1
16:30 16:45	0	0	0	0	0	0	0
16:45 17:00	0	0	0	0	0	0	0
17:00 17:15	1	1	2	0	0	0	2
17:15 17:30	0	1	1	0	0	0	1
17:30 17:45	0	1	1	0	0	0	1
17:45 18:00	0	0	0	0	0	0	0
Total	2	11	13	9	2	11	24



Transportation Services - Traffic Services

Turning Movement Count - Study Results

AGES DR @ HAWTHORNE RD

Survey Date: Wednesday, January 25, 2017

WO No: 36659

Start Time: 07:00

Device: Miovision

Full Study Heavy Vehicles

HAWTHORNE RD

AGES DR

Northbound

Southbound

Eastbound

Westbound

Time Period	Northbound			N TOT	Southbound			S TOT	STR TOT	Eastbound			E TOT	Westbound			W TOT	STR TOT	Grand Total	
	LT	ST	RT		LT	ST	RT			LT	ST	RT		LT	ST	RT				
07:00 07:15	0	17	0	17	1	13	2	16	33	13	0	0	13	0	1	4	5	18	51	
07:15 07:30	0	15	0	15	2	17	3	22	37	12	0	2	14	0	0	0	0	14	51	
07:30 07:45	2	28	1	31	1	13	4	18	49	13	0	2	15	0	0	2	2	17	66	
07:45 08:00	1	31	0	32	1	23	7	31	63	7	0	2	9	1	0	2	3	12	75	
08:00 08:15	2	42	0	44	1	23	2	26	70	3	0	1	4	0	0	1	1	5	75	
08:15 08:30	1	26	0	27	2	10	4	16	43	6	0	3	9	3	0	3	6	15	58	
08:30 08:45	3	31	0	34	1	18	8	27	61	9	0	3	12	0	0	0	0	12	73	
08:45 09:00	0	27	0	27	3	22	4	29	56	16	1	1	18	0	1	5	6	24	80	
09:00 09:15	0	33	0	33	1	21	3	25	58	6	0	1	7	0	0	1	1	8	66	
09:15 09:30	1	49	1	51	0	15	7	22	73	8	0	0	8	1	0	2	3	11	84	
09:30 09:45	0	54	0	54	2	17	10	29	83	8	0	4	12	1	0	0	1	13	96	
09:45 10:00	0	26	1	27	1	21	8	30	57	3	0	2	5	1	0	2	3	8	65	
11:30 11:45	1	27	0	28	0	11	6	17	45	6	0	1	7	0	0	0	0	7	52	
11:45 12:00	0	25	2	27	0	18	12	30	57	3	0	3	6	1	0	0	1	7	64	
12:00 12:15	0	20	0	20	2	22	6	30	50	5	0	2	7	0	0	0	0	7	57	
12:15 12:30	0	27	0	27	1	18	9	28	55	7	0	0	7	0	0	1	1	8	63	
12:30 12:45	1	25	0	26	1	23	5	29	55	7	0	2	9	0	0	2	2	11	66	
12:45 13:00	0	20	1	21	0	33	4	37	58	6	0	0	6	0	0	1	1	7	65	
13:00 13:15	2	13	0	15	3	18	6	27	42	3	0	1	4	0	0	0	0	4	46	
13:15 13:30	2	21	0	23	1	26	1	28	51	5	0	0	5	0	0	0	0	5	56	
15:00 15:15	1	19	0	20	0	14	11	25	45	3	0	0	3	0	0	1	1	4	49	
15:15 15:30	3	10	0	13	0	18	11	29	42	6	0	1	7	0	0	0	0	7	49	
15:30 15:45	1	11	0	12	1	23	10	34	46	5	0	1	6	0	0	0	0	6	52	
15:45 16:00	3	20	0	23	1	22	22	45	68	3	0	0	3	0	0	0	0	3	71	
16:00 16:15	2	17	0	19	0	20	8	28	47	1	0	2	3	2	0	2	4	7	54	
16:15 16:30	1	17	0	18	2	17	12	31	49	2	0	1	3	0	0	0	0	3	52	
16:30 16:45	0	11	1	12	0	25	9	34	46	1	0	0	1	0	0	0	0	1	47	
16:45 17:00	2	8	0	10	1	15	7	23	33	3	0	0	3	0	0	0	0	3	36	
17:00 17:15	1	6	0	7	0	13	3	16	23	4	0	1	5	0	0	0	0	5	28	
17:15 17:30	2	16	1	19	0	16	3	19	38	3	0	0	3	0	0	1	1	4	42	
17:30 17:45	2	4	0	6	0	10	3	13	19	6	0	0	6	0	0	0	0	6	25	
17:45 18:00	0	5	0	5	1	10	2	13	18	1	0	1	2	0	0	0	0	2	20	
Total:	None	34	701	8	743	30	585	212	827	1570	184	1	37	222	10	2	30	42	264	1,834



Transportation Services - Traffic Services

Turning Movement Count - Study Results

AGES DR @ HAWTHORNE RD

Survey Date: Wednesday, January 25, 2017

WO No: 36659

Start Time: 07:00

Device: Miovision

Full Study 15 Minute U-Turn Total

HAWTHORNE RD

AGES DR

Time Period		Northbound U-Turn Total	Southbound U-Turn Total	Eastbound U-Turn Total	Westbound U-Turn Total	Total
07:00	07:15	0	0	0	0	0
07:15	07:30	0	0	0	0	0
07:30	07:45	0	0	0	0	0
07:45	08:00	0	0	1	0	1
08:00	08:15	0	0	0	0	0
08:15	08:30	0	0	0	0	0
08:30	08:45	0	1	0	0	1
08:45	09:00	0	0	0	0	0
09:00	09:15	0	0	0	0	0
09:15	09:30	0	0	0	0	0
09:30	09:45	0	0	0	0	0
09:45	10:00	0	0	0	0	0
11:30	11:45	1	0	0	0	1
11:45	12:00	0	0	0	0	0
12:00	12:15	0	0	0	0	0
12:15	12:30	0	0	0	0	0
12:30	12:45	0	0	0	0	0
12:45	13:00	0	0	0	0	0
13:00	13:15	0	0	0	0	0
13:15	13:30	0	0	0	0	0
15:00	15:15	0	0	0	0	0
15:15	15:30	0	0	0	0	0
15:30	15:45	0	0	0	1	1
15:45	16:00	0	0	0	0	0
16:00	16:15	0	0	0	0	0
16:15	16:30	0	0	0	0	0
16:30	16:45	0	0	0	0	0
16:45	17:00	0	0	0	0	0
17:00	17:15	0	0	0	0	0
17:15	17:30	0	0	0	0	0
17:30	17:45	0	0	0	0	0
17:45	18:00	0	0	0	0	0
Total		1	1	1	1	4

Traffic Signal Timing

City of Ottawa, Transportation Services Department

Traffic Signal Operations Unit

Intersection:	Main: Hawthorne	Side: Ages
Controller:	MS-3200	TSD: 6447
Author:	Matthew Anderson	Date: 14-Jun-2021

Existing Timing Plans[†]

	Plan					Ped Minimum Time		
	AM Peak 1	Off Peak 2	PM Peak 3	Night 4	Weekend 5	Walk	DW	A+R
Cycle	90	85	95	65	70			
Offset	70	78	48	45	34			
NB Thru	60	55	65	36	40	7	20	4.2+1.7
SB Thru	60	55	65	36	40	7	20	4.2+1.7
EB Thru	30	30	30	29	30	7	16	3.3+3.0
WB Thru	30	30	30	29	30	7	16	3.3+3.0

Phasing Sequence[‡]

Plan:

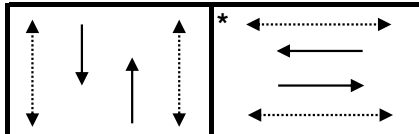

Schedule

Weekday		Saturday		Sunday	
Time	Plan	Time	Plan	Time	Plan
0:15	4	0:15	4	0:15	4
6:30	1	6:30	2	6:30	2
9:30	2	11:00	5	21:00	4
15:00	3	19:30	2		
18:30	2	22:00	4		
21:30	4				

Notes

†: Time for each direction includes amber and all red intervals

‡: Start of first phase should be used as reference point for offset

Asterisk (*) Indicates actuated phase

(fp): Fully Protected Left Turn

←.....→ Pedestrian signal

Cost is \$59.96 (\$53.06 + HST)

APPENDIX E

Collision Data

Record #	Date	Time	Location	Environment	Light	Surface Conditions	Collision Classification	Impact Type
18-4200	Thursday, May 3, 2018	11:53:00 AM	Intersection	Rain	Daylight	Wet	P.D. only	Angle
16-11708	Monday, December 12, 2016	6:49:00 PM	Intersection	Snow	Dark	Wet	P.D. only	Angle
16-2407	Thursday, February 25, 2016	6:15:00 PM	Intersection	Snow	Dark	Ice	P.D. only	Angle
15-2396	Thursday, February 12, 2015	6:20:00 AM	Intersection	Snow	Dawn	Loose Snow	P.D. only	Angle
14-7758	Tuesday, August 5, 2014	7:46:00 PM	Intersection	Clear	Daylight	Dry	Non-fatal injury	Angle
17-68	Wednesday, December 20, 2017	4:05:00 PM	Intersection	Clear	Dusk	Dry	P.D. only	Read end
15-10039	Friday, September 25, 2015	4:43:00 PM	Intersection	Clear	Daylight	Dry	P.D. only	Read end
16-11293	Monday, December 5, 2016	8:01:00 AM	Segment	Snow	Daylight	Slush	P.D. only	Sideswipe
16-1550	Thursday, February 11, 2016	1:01:00 PM	Intersection	Clear	Daylight	Wet	P.D. only	Sideswipe
15-12646	Monday, December 7, 2015	14:17:00	Segment	Clear	Daylight	Dry	P.D. only	Sideswipe
18-6702	Friday, July 20, 2018	1:37:00 PM	Intersection	Clear	Daylight	Dry	P.D. only	SMV other
15-6190	Monday, June 1, 2015	11:56:00 AM	Intersection	Clear	Daylight	Dry	P.D. only	SMV other
15-328	Thursday, January 8, 2015	5:03:00 AM	Segment	Snow	Dark	Packed snow	P.D. only	SMV other
18-1321	Thursday, February 1, 2018	7:58:00 AM	Intersection	Snow	Daylight	Loose Snow	P.D. only	Turning Movement
17-6032	Friday, October 20, 2017	4:07:00 PM	Segment	Clear	Daylight	Dry	P.D. only	Turning movement
17-67	Tuesday, August 8, 2017	2:30:00 PM	Intersection	Clear	Daylight	Dry	P.D. only	Turning Movement
16-7054	Wednesday, July 27, 2016	11:31:00 AM	Intersection	Clear	Daylight	Dry	P.D. only	Turning Movement
14-6897	Monday, July 7, 2014	10:49:00 AM	Intersection	Clear	Daylight	Dry	P.D. only	Turning Movement

APPENDIX F

TDM Checklist

3149 Hawthorne Road

TDM-Supportive Development Design and Infrastructure Checklist:
Non-Residential Developments (office, institutional, retail or industrial)

Legend	
REQUIRED	The Official Plan or Zoning By-law provides related guidance that must be followed
BASIC	The measure is generally feasible and effective, and in most cases would benefit the development and its users
BETTER	The measure could maximize support for users of sustainable modes, and optimize development performance

TDM-supportive design & infrastructure measures: <i>Non-residential developments</i>		Check if completed & add descriptions, explanations or plan/drawing references
1. WALKING & CYCLING: ROUTES		
1.1 Building location & access points		
BASIC	1.1.1 Locate building close to the street, and do not locate parking areas between the street and building entrances	<input checked="" type="checkbox"/> Refer to Site Plan.
BASIC	1.1.2 Locate building entrances in order to minimize walking distances to sidewalks and transit stops/stations	<input type="checkbox"/>
BASIC	1.1.3 Locate building doors and windows to ensure visibility of pedestrians from the building, for their security and comfort	<input checked="" type="checkbox"/> Refer to Site Plan.
1.2 Facilities for walking & cycling		
REQUIRED	1.2.1 Provide convenient, direct access to stations or major stops along rapid transit routes within 600 metres; minimize walking distances from buildings to rapid transit; provide pedestrian-friendly, weather-protected (where possible) environment between rapid transit accesses and building entrances; ensure quality linkages from sidewalks through building entrances to integrated stops/stations (<i>see Official Plan policy 4.3.3</i>)	<input checked="" type="checkbox"/> To be provided as applicable for site location.
REQUIRED	1.2.2 Provide safe, direct and attractive pedestrian access from public sidewalks to building entrances through such measures as: reducing distances between public sidewalks and major building entrances; providing walkways from public streets to major building entrances; within a site, providing walkways along the front of adjoining buildings, between adjacent buildings, and connecting areas where people may congregate, such as courtyards and transit stops; and providing weather protection through canopies, colonnades, and other design elements wherever possible (<i>see Official Plan policy 4.3.12</i>)	<input checked="" type="checkbox"/> To be provided as applicable for site location. Along with the internal sidewalks shown on the site plan, a 2 m standard sidewalk is proposed to be implemented on the east side of Hawthorne Road between Ages Drive and the site access

3149 Hawthorne Road

TDM-supportive design & infrastructure measures: <i>Non-residential developments</i>		Check if completed & add descriptions, explanations or plan/drawing references
REQUIRED	1.2.3 Provide sidewalks of smooth, well-drained walking surfaces of contrasting materials or treatments to differentiate pedestrian areas from vehicle areas, and provide marked pedestrian crosswalks at intersection sidewalks (see <i>Official Plan policy 4.3.10</i>)	<input checked="" type="checkbox"/> To be provided as applicable for site location.
REQUIRED	1.2.4 Make sidewalks and open space areas easily accessible through features such as gradual grade transition, depressed curbs at street corners and convenient access to extra-wide parking spaces and ramps (see <i>Official Plan policy 4.3.10</i>)	<input checked="" type="checkbox"/> To be provided as applicable for site location.
REQUIRED	1.2.5 Include adequately spaced inter-block/street cycling and pedestrian connections to facilitate travel by active transportation. Provide links to the existing or planned network of public sidewalks, multi-use pathways and on-road cycle routes. Where public sidewalks and multi-use pathways intersect with roads, consider providing traffic control devices to give priority to cyclists and pedestrians (see <i>Official Plan policy 4.3.11</i>)	<input checked="" type="checkbox"/> Sidewalk connection indicated on site plan. No change to cycle route connection.
BASIC	1.2.6 Provide safe, direct and attractive walking routes from building entrances to nearby transit stops	<input checked="" type="checkbox"/>
BASIC	1.2.7 Ensure that walking routes to transit stops are secure, visible, lighted, shaded and wind-protected wherever possible	<input checked="" type="checkbox"/>
BASIC	1.2.8 Design roads used for access or circulation by cyclists using a target operating speed of no more than 30 km/h, or provide a separated cycling facility	<input type="checkbox"/>
1.3 Amenities for walking & cycling		
BASIC	1.3.1 Provide lighting, landscaping and benches along walking and cycling routes between building entrances and streets, sidewalks and trails	<input type="checkbox"/>
BASIC	1.3.2 Provide wayfinding signage for site access (where required, e.g. when multiple buildings or entrances exist) and egress (where warranted, such as when directions to reach transit stops/stations, trails or other common destinations are not obvious)	<input type="checkbox"/>

3149 Hawthorne Road

TDM-supportive design & infrastructure measures: <i>Non-residential developments</i>		Check if completed & add descriptions, explanations or plan/drawing references
2. WALKING & CYCLING: END-OF-TRIP FACILITIES		
2.1 Bicycle parking		
REQUIRED	2.1.1 Provide bicycle parking in highly visible and lighted areas, sheltered from the weather wherever possible (see <i>Official Plan policy 4.3.6</i>)	<input checked="" type="checkbox"/>
REQUIRED	2.1.2 Provide the number of bicycle parking spaces specified for various land uses in different parts of Ottawa; provide convenient access to main entrances or well-used areas (see <i>Zoning By-law Section 111</i>)	<input checked="" type="checkbox"/> 10 Bicycle Parking Spaces are proposed to be provided, exceeding the 9 required.
REQUIRED	2.1.3 Ensure that bicycle parking spaces and access aisles meet minimum dimensions; that no more than 50% of spaces are vertical spaces; and that parking racks are securely anchored (see <i>Zoning By-law Section 111</i>)	<input checked="" type="checkbox"/>
BASIC	2.1.4 Provide bicycle parking spaces equivalent to the expected number of commuter cyclists (assuming the cycling mode share target is met), plus the expected peak number of customer/visitor cyclists	<input checked="" type="checkbox"/> No Bicycle Trips are projected, therefore 10 spaces is likely adequate
BETTER	2.1.5 Provide bicycle parking spaces equivalent to the expected number of commuter and customer/visitor cyclists, plus an additional buffer (e.g. 25 percent extra) to encourage other cyclists and ensure adequate capacity in peak cycling season	<input checked="" type="checkbox"/> No Bicycle Trips are projected, therefore 10 spaces is likely adequate
2.2 Secure bicycle parking		
REQUIRED	2.2.1 Where more than 50 bicycle parking spaces are provided for a single office building, locate at least 25% of spaces within a building/structure, a secure area (e.g. supervised parking lot or enclosure) or bicycle lockers (see <i>Zoning By-law Section 111</i>)	<input checked="" type="checkbox"/> Not Applicable
BETTER	2.2.2 Provide secure bicycle parking spaces equivalent to the expected number of commuter cyclists (assuming the cycling mode share target is met)	<input type="checkbox"/>
2.3 Shower & change facilities		
BASIC	2.3.1 Provide shower and change facilities for the use of active commuters	<input type="checkbox"/>
BETTER	2.3.2 In addition to shower and change facilities, provide dedicated lockers, grooming stations, drying racks and laundry facilities for the use of active commuters	<input type="checkbox"/>
2.4 Bicycle repair station		
BETTER	2.4.1 Provide a permanent bike repair station, with commonly used tools and an air pump, adjacent to the main bicycle parking area (or secure bicycle parking area, if provided)	<input type="checkbox"/>

3149 Hawthorne Road

TDM-supportive design & infrastructure measures: <i>Non-residential developments</i>		Check if completed & add descriptions, explanations or plan/drawing references
3. TRANSIT		
3.1 Customer amenities		
BASIC	3.1.1 Provide shelters, lighting and benches at any on-site transit stops	<input type="checkbox"/>
BASIC	3.1.2 Where the site abuts an off-site transit stop and insufficient space exists for a transit shelter in the public right-of-way, protect land for a shelter and/or install a shelter	<input type="checkbox"/>
BETTER	3.1.3 Provide a secure and comfortable interior waiting area by integrating any on-site transit stops into the building	<input type="checkbox"/>
4. RIDESHARING		
4.1 Pick-up & drop-off facilities		
BASIC	4.1.1 Provide a designated area for carpool drivers (plus taxis and ride-hailing services) to drop off or pick up passengers without using fire lanes or other no-stopping zones	<input type="checkbox"/>
4.2 Carpool parking		
BASIC	4.2.1 Provide signed parking spaces for carpools in a priority location close to a major building entrance, sufficient in number to accommodate the mode share target for carpools	<input type="checkbox"/>
BETTER	4.2.2 At large developments, provide spaces for carpools in a separate, access-controlled parking area to simplify enforcement	<input type="checkbox"/>
5. CARSHARING & BIKESHARING		
5.1 Carshare parking spaces		
BETTER	5.1.1 Provide carshare parking spaces in permitted non-residential zones, occupying either required or provided parking spaces (<i>see Zoning By-law Section 94</i>)	<input type="checkbox"/>
5.2 Bikeshare station location		
BETTER	5.2.1 Provide a designated bikeshare station area near a major building entrance, preferably lighted and sheltered with a direct walkway connection	<input type="checkbox"/>

3149 Hawthorne Road

TDM-supportive design & infrastructure measures: <i>Non-residential developments</i>		Check if completed & add descriptions, explanations or plan/drawing references
6. PARKING		
6.1 Number of parking spaces		
REQUIRED	6.1.1 Do not provide more parking than permitted by zoning, nor less than required by zoning, unless a variance is being applied for	<input checked="" type="checkbox"/> 37 new parking spaces are proposed, 84 spaces are required per the Zoning By-Law. However, the 190 parking spaces at the adjacent 3169 Hawthorne Road property will be shared with the proposed development, satisfying the parking requirements.
BASIC	6.1.2 Provide parking for long-term and short-term users that is consistent with mode share targets, considering the potential for visitors to use off-site public parking	<input type="checkbox"/>
BASIC	6.1.3 Where a site features more than one use, provide shared parking and reduce the cumulative number of parking spaces accordingly (<i>see Zoning By-law Section 104</i>)	<input type="checkbox"/>
BETTER	6.1.4 Reduce the minimum number of parking spaces required by zoning by one space for each 13 square metres of gross floor area provided as shower rooms, change rooms, locker rooms and other facilities for cyclists in conjunction with bicycle parking (<i>see Zoning By-law Section 111</i>)	<input type="checkbox"/>
6.2 Separate long-term & short-term parking areas		
BETTER	6.2.1 Separate short-term and long-term parking areas using signage or physical barriers, to permit access controls and simplify enforcement (i.e. to discourage employees from parking in visitor spaces, and vice versa)	<input type="checkbox"/>
7. OTHER		
7.1 On-site amenities to minimize off-site trips		
BETTER	7.1.1 Provide on-site amenities to minimize mid-day or mid-commute errands	<input type="checkbox"/>

APPENDIX G

Truck Turning Diagrams

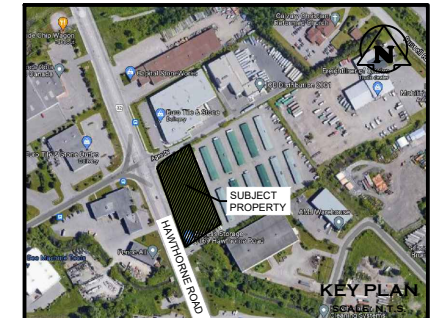
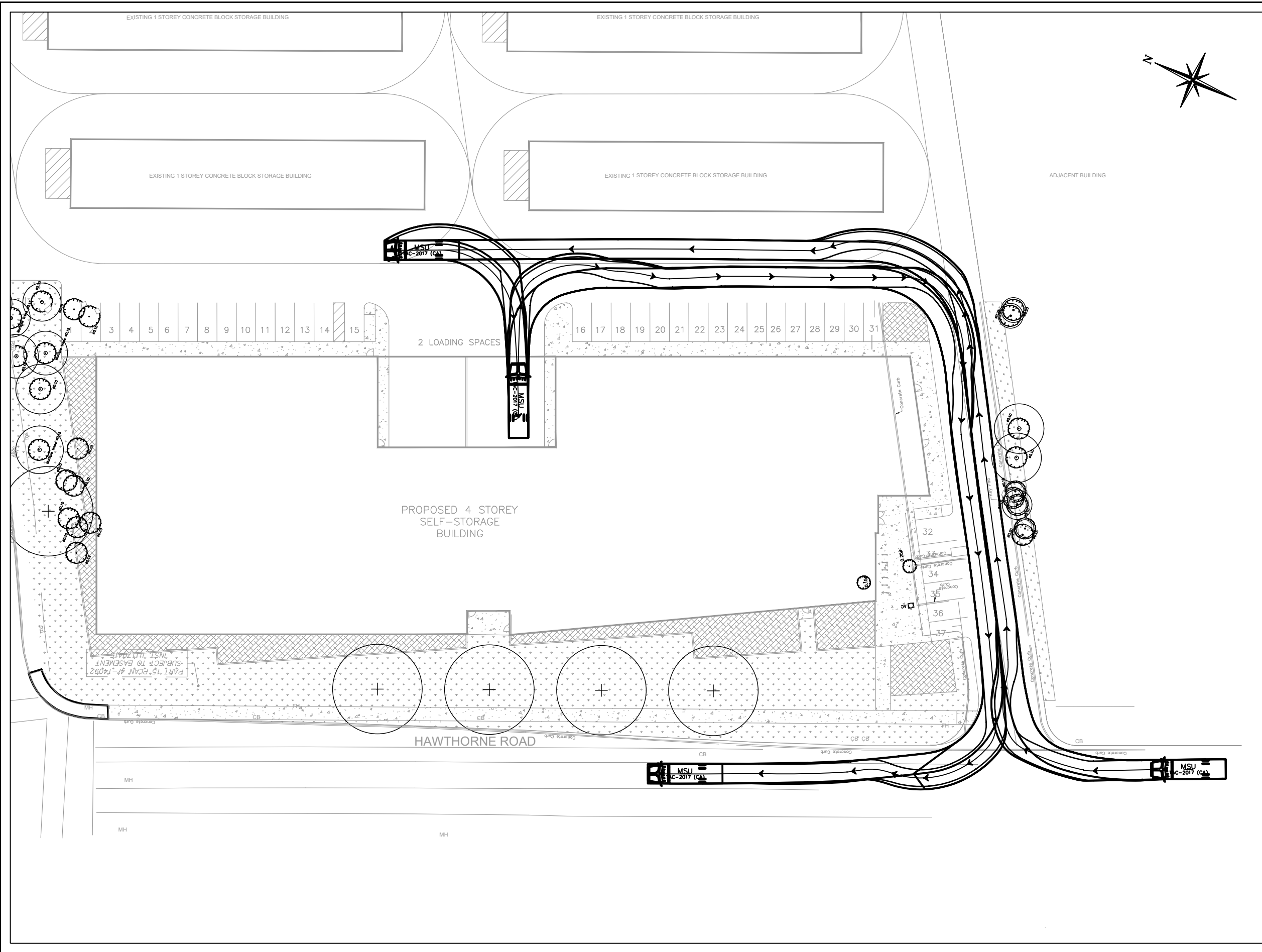

DRAFT
FOR DISCUSSION PURPOSES ONLY

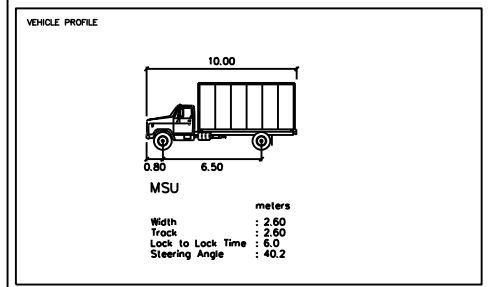
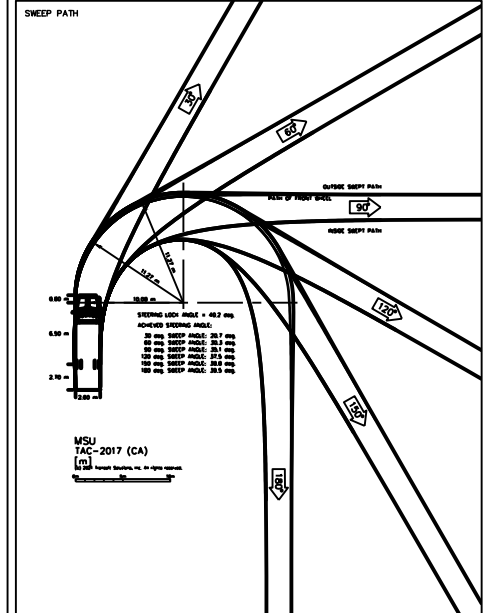

No.	ISSUE	DATE: MM/DD/YYYY
0	ISSUED FOR 1st SUBMISSION	09/23/2021

Project
**3149 HAWTHORNE ROAD
SELF STORAGE, CITY OF OTTAWA**

Drawing
**MEDIUM SINGLE UNIT (MSU) TRUCK
TURNING ANALYSIS**

CROZIER
CONSULTING ENGINEERS

ADMIRAL BUILDING
1 FIRST STREET, SUITE 200
COLLINGWOOD, ON, L9Y 1A1
705-446-3510 T
705-446-3520 F
WWW.CROZIER.CA
INFO@CROZIER.CA

Drawn By P.B. Design By Project **2112-6007**
Check By P.A. Check By Scale N.T.S. Drawing **T 300**

APPENDIX H

Level of Service Excerpts

Level of Service Definitions

Two-Way Stop Controlled Intersections

Level of Service	Control Delay per Vehicle (seconds)	Interpretation
A	≤ 10	EXCELLENT. Large and frequent gaps in traffic on the main roadway. Queuing on the minor street is rare.
B	> 10 and ≤ 15	VERY GOOD. Many gaps exist in traffic on the main roadway. Queuing on the minor street is minimal.
C	> 15 and ≤ 25	GOOD. Fewer gaps exist in traffic on the main roadway. Delay on minor approach becomes more noticeable.
D	> 25 and ≤ 35	FAIR. Infrequent and shorter gaps in traffic on the main roadway. Queue lengths develop on the minor street.
E	> 35 and ≤ 50	POOR. Very infrequent gaps in traffic on the main roadway. Queue lengths become noticeable.
F	> 50	UNSATISFACTORY. Very few gaps in traffic on the main roadway. Excessive delay with significant queue lengths on the minor street.

Adapted from Highway Capacity Manual 2000, Transportation Research Board

6 Vehicular Level of Service (LOS)

The following details outlining the evaluation of Vehicular Level of Service are extracted from the 2009 Transportation Impact Assessment Guidelines. As the TIA update is carried out, these parameters may be updated.

6.1 Intersection Capacity Analysis

An evaluation is required of any critical intersection within the study area that will potentially be affected by site generated traffic volumes during any or all of the relevant time periods and scenarios. Summaries are to be provided in tabular format clearly identifying intersection performance under existing and future traffic conditions. Where development is anticipated to proceed in phases or stages, projected performance for all intersections must be documented for the end of each phase.

Detailed output from analysis software is to be provided in an appendix to the report and copies of the electronic files should be provided on CD. Appendix B outlines parameters to be used in operational analysis of signalized intersections.

All volume to capacity (V/C) calculations relating to future conditions should be determined using signal timing optimized for the volume conditions being studied. The V/C ratio for an intersection is defined as the sum of equivalent volumes for all critical movements divided by the sum of capacities for all critical movements assuming that the V/C ratios for critical movements can be equalized. In cases where minimum pedestrian phase times prevent equalizing the level of service for critical movements, then the V/C ratio for the most heavily saturated critical movement should be considered as the V/C ratio for the intersection. Adjustment for the impact of pedestrian activated control is permitted provided detailed supporting analysis including projected pedestrian volumes is provided and discussed in advance with traffic engineering staff.

In the case of planning level or functional design projects, practitioners should undertake a two and a half hour peak period observation of volumes (typically 6:30 – 9:00 AM) to verify that the traffic volumes through the intersections reflect existing demands and to identify unusual operating conditions. For operational studies, peak hour observations are acceptable. Timing of observations and conditions observed should be documented in writing in the report.

LEVEL OF SERVICE	VOLUME TO CAPACITY RATIO
A	0 to 0.60
B	0.61 to 0.70
C	0.71 to 0.80
D	0.81 to 0.90
E	0.91 to 1.00
F	> 1.00

Intersection evaluations should identify:

- Signalized Intersections – V/C ratios for the overall intersection, as defined above, and individual movements; and
- Unsignalized Intersections - Level of service (LOS) where the LOS is between A and E; V/C where capacity is based on gap analysis if intersection LOS is F.

Existing signal timing information such as phasing, pedestrian minimums and clearance intervals must be used as a base to analyze the existing capacity of signalized intersections. This signal timing data should be obtained from the City of Ottawa Traffic Operations Division. Operational design of the signals analyzed should be in accordance with City of Ottawa signal operation practices.

3149 Hawthorne Road Multi-Modal Level of Service Targets

Multi-Modal Levels of Service Targets outlined in Red.

Exhibit 22 – Minimum Desirable MMLOS Targets by Official Plan Policy/Designation & Road Class

OP Designation / Policy Area	Road Class	PLOS	Bicycle - BLOS				Transit - TLOS ³			Truck - TrLOS		Auto - LOS ⁴
			Cross-town Bikeway	Spine Route	Local Route	Elsewhere	Rapid Transit Corridor	TP - Continuous Lanes	TP - Isolated Measures	Truck Route	Other	
Land-Use Designation												
Central Area	Arterial	A	A	C	B	D	A	C	D	D	E	E
	Collector	A	A	B	B	D	A	C	D	D	No target	E
	Local	A	A	B	B	D	A	C	D	E	No target	E
Developing Community	Arterial	C	B	C	B	D	B	C	D	D	No target	D
	Collector	C	B	C	B	D	B	C	D	D	No target	D
	Local	C	B	C	B	D	B	C	D	N/A	No target	D
Employment Area	Arterial	C	B	C	C	E	B	C	D	B	D	D
	Collector	C	B	C	C	E	B	C	D	B	D	D
	Local	C	B	D	C	No target	B	C	D	D	E	D
Entreprise Area	Arterial	C	B	C	B	D	B	C	D	B	E	D
	Collector	C	B	C	B	D	B	C	D	B	E	D
	Local	C	B	C	B	No target	B	C	D	D	No target	D
General Rural Area	Arterial	No target	N/A	D	D	No target	N/A	N/A	N/A	C	E	D
	Collector	No target	N/A	D	D	No target	N/A	N/A	N/A	C	No target	D
	Local	No target	N/A	D	D	No target	N/A	N/A	N/A	No target	No target	D
General Urban Area	Arterial	C	B	C	B	D	B	C	D	D	E	D
	Collector	C	B	C	B	D	B	C	D	D	No target	D
	Local	C	B	C	B	D	B	C	D	N/A	No target	D
Mixed Use Centre	Arterial	C	A	C	B	D	B	C	D	D	E	D
	Collector	C	A	B	B	D	B	C	D	D	No target	D
	Local	C	A	B	B	D	B	C	D	N/A	No target	D
Village	Arterial	C	B	C	B	D	N/A	N/A	N/A	D	No target	D
	Collector	C	B	C	B	D	N/A	N/A	N/A	D	No target	D
	Local	C	B		B	D	N/A	N/A	N/A	N/A	No target	D
Traditional Main Street	Arterial	B	A	C	C	D	B	C	D	D	E	D
	Collector	B	A	C	C	D	B	C	D	D	No target	D
Arterial Main Street	Arterial	C	B	C	D	D	B	C	D	D	E	D
All Other Designations	Arterial	D	B	C	C	D	B	C	D	D	No target	D
	Collector	D	B	C	C	D	B	C	D	D	No target	D
	Local	D	B	C	C	D	B	C	D	N/A	No target	D
Policy Area ²												
Within 600m of a rapid transit station	Arterial	A	A	C	B	D	A	C	D	D	E	E
	Collector	A	A	B	B	D	A	C	D	D	No target	E
	Local	A	A	B	B	D	A	C	D	N/A	No target	E
Within 300m of a school	Arterial	A	A	C	B	D	A	C	D	D	E	E
	Collector	A	A	B	B	D	A	C	D	D	No target	E
	Local	A	A	B	B	D	A	C	D	N/A	No target	E

1. This table indicates the minimum desirable target. Efforts should be made to exceed these minimum targets whenever possible, without negatively impacting the ability to achieve the minimum targets for other modes.

2. Where a policy area applies to a project or area, the modal targets should reflect the policy area targets regardless of the land use designation.

3. Transit targets are intended to be applied only for streets with a proposed or existing transit route.

4. Auto LOS is based on the two and a half hour peak period.

5. Minimum guidelines as dictated by City policy must be maintained, regardless of MMLOS targets.

N/A - Not applicable

3149 Hawthorne Road Multi-Modal Level of Service

Exhibit 4 – PLOS Segment Evaluation Table

Sidewalk Width (m)	Boulevard Width (m)	Motor Vehicle Traffic Volume (AADT)	Presence of On-street Parking	Segment PLOS			
				Operating Speed (km/h)			
				≤30	>30 or 50	>50 or 60	>60 ¹
2.0 or more	> 2	≤ 3000	N/A	A	A	A	B
		> 3000	Yes	A	B	B	N/A
			No	A	B	C	D
	0.5 to 2	≤ 3000	N/A	A	A	A	B
		> 3000	Yes	A	B	C	N/A
			No	A	C	D	E
	0	≤ 3000	NA	A	B	C	D
		> 3000	Yes	B	B	D	N/A
			No	B	C	E	F
1.8	> 2	≤ 3000	N/A	A	A	A	B
		> 3000	Yes	A	B	C	N/A
			No	A	C	D	E
	0.5 to 2	≤ 3000	N/A	A	B	B	D
		> 3000	Yes	A	C	C	N/A
			No	B	C	E	E
	0	≤ 3000	N/A	A	B	C	D
		> 3000	Yes	B	C	D	N/A
			No	C	D	F	F
1.5	> 2	≤ 3000	N/A	C	C	C	C
		> 3000	Yes	C	C	D	N/A
			No	C	D	E	E
	0.5 to 2	≤ 3000	N/A	C	C	C	D
		> 3000	Yes	C	C	D	N/A
			No	D	E	E	E
	0	N/A	D	E	F ²	F ²	
	<1.5	N/A		F ³	F ³	F ³	F ³
	No sidewalk	N/A		C ⁴	F ³	F ³	F ³

Existing

Notes:

1. On-street parking not provided on roadways with posted speed of 70 km/h or more
2. Sidewalk must be 1.8 m wide if no separation is provided (curb-face sidewalk) where speeds are high
3. Sidewalk must be 1.5 m wide to meet Provincial accessibility standards
4. Ottawa Pedestrian Plan, 2014: "all new and reconstructed urban local roads where pedestrian facilities are required in accordance with these policies but no dedicated pedestrian facility is provided, require that roads be designed for a speed of 30 km/h or lower (pending development of a new 30 km/h roadway design standard)." Where a roadway is specifically designed as 'shared space', with appropriate design controls and features, it can achieve LOS A.
5. Where a multi-use path is provided in lieu of sidewalks, the MUP can be evaluated using the same methodology.

Exhibit 11 – BLOS Segment Evaluation Table

Type of Bikeway		LOS
Physically Separated Bikeway (cycle tracks, protected bike lanes and multi-use paths). Physical separation refers to, but is not limited to, curbs, raised medians, bollards and parking lanes (adjacent to the bike lane along the travelled way i.e. not curbside).		A
Bike Lanes Not Adjacent Parking Lane - Select Worst Scoring Criteria		
No. of Travel Lanes	1 travel lane in each direction	A
	2 travel lanes in each direction separated by a raised median	B
	2 travel lanes in each direction without a separating median	C
	More than 2 travel lanes in each direction	D
Bike Lane Width	> 1.8 m wide bike lane (includes marked buffer and paved gutter width)	A
	≥1.5 m to <1.8 m wide bike lane (includes marked buffer and paved gutter width)	B
	≥1.2 m to <1.5 m wide bike lane (includes marked buffer and paved gutter width)	C
Operating Speed	≤ 50 km/h operating speed	A
	60 km/h operating speed	C
	≥ 70 km/h operating speed	E
Bike lane blockage (commercial areas)	Rare	A
	Frequent	C
Bike Lanes Adjacent to curbside Parking Lane - Select Worst Scoring Criteria		
No. of Travel Lanes	1 travel lane in each direction	A
	2 or more travel lanes in each direction	C
Bike Lane and Parking Lane Width	4.5 m wide bike lane plus parking lane (includes marked buffer and paved gutter width)	A
	4.25 m wide bike lane plus parking lane (includes marked buffer and paved gutter width)	B
	≤ 4.0 m wide bike lane plus parking lane (includes marked buffer and paved gutter width)	C
Operating Speed	< 40 km/h operating speed	A
	50 km/h operating speed	B
	60 km/h operating speed	D
	≥ 70 km/h operating speed	F
Bike lane blockage (commercial areas)	Rare	A
	Frequent	C
Mixed Traffic		
No. of Travel Lanes and Operating Speed	2 travel lanes; ≤ 40 km/h; no marked centerline or classified as residential	A
	2 to 3 travel lanes; ≤ 40 km/h	B
	2 travel lanes; 50 km/h; no marked centerline or classified as residential	B
	2 to 3 travel lanes; 50 km/h	D
	4 to 5 travel lanes; ≤ 40 km/h	D
	4 to 5 travel lanes; ≥ 50 km/h	E
	6 or more travel lanes; ≤ 40 km/h	E
≥ 60 km/h	F	
Unsignalized Crossing along Route: no median refuge		
No. of Travel Lanes on Side Street and Operating Speed	3 or less lanes being crossed; ≤ 40 km/h	A
	4 to 5 lanes being crossed; ≤ 40 km/h	B
	3 or less lanes being crossed; 50 km/h	B
	4 to 5 lanes being crossed; 50 km/h	C
	3 or less lanes being crossed; 60 km/h	C
	4 to 5 lanes being crossed; 60 km/h	D
	6 or more lanes being crossed; ≤ 40 km/h	E
	3 or less lanes being crossed; ≥ 65 km/h	E
	6 or more lanes being crossed; ≥ 50 km/h	F
4 to 5 lanes being crossed; ≥ 65 km/h	F	
Unsignalized Crossing along Route: with median refuge (> 1.8 m wide)		
No. of Travel Lanes on Side Street and Operating Speed	5 or less lanes being crossed; ≤ 40 km/h	A
	3 or less lanes being crossed; 50 km/h	A
	6 or more lanes being crossed; ≤ 40 km/h	B
	4 to 5 lanes being crossed; 50 km/h	B
	3 or less lanes being crossed; 60 km/h	B
	6 or more lanes being crossed; 50 km/h	C
	4 to 5 lanes being crossed; 60 km/h	C
	3 or less lanes being crossed; ≥ 65 km/h	D
	6 or more lanes being crossed; 60 km/h	E
	4 to 5 lanes being crossed; ≥ 65 km/h	E
	6 or more lanes being crossed; ≥ 65 km/h	F

Existing

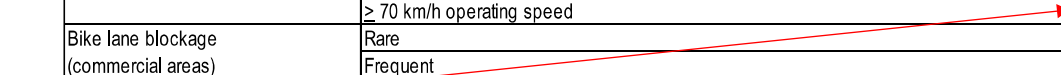

Exhibit 19 – TkLOS Evaluation Methodology

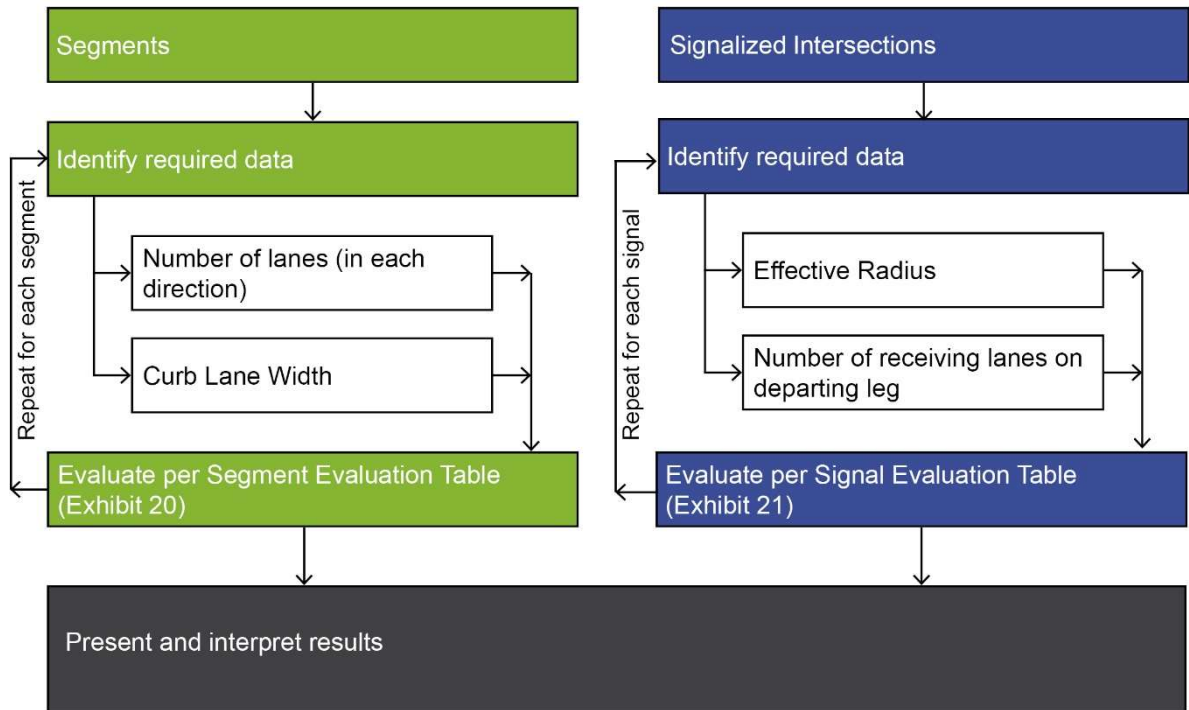

Exhibit 20 – TkLOS Segment Evaluation Table

Curb Lane Width (m)	Only two travel lanes (one in each direction)	More than two travel lanes
>3.7	B	A
≤3.5	C	A
Existing ≤3.3	D	C
≤3.2	E	D
≤3	F	E

Exhibit 21 – TkLOS Signalized Intersection Evaluation Table























Effective Corner Radius	One receiving lane on departure from intersection	More than one receiving lane on departure from intersection
< 10m	F	D
10 to 15m	E	B
> 15m	C	A

APPENDIX I

Synchro Capacity Analysis













Lanes, Volumes, Timings
1: Hawthorne Road & Ages Drive

2021 AM Existing Conditions

												
Lane Group	EBL	EBT	EBR	WBL	WBT	WBR	NBL	NBT	NBR	SBL	SBT	SBR
Lane Configurations												
Traffic Volume (vph)	84	0	27	7	0	11	55	796	12	17	412	146
Future Volume (vph)	84	0	27	7	0	11	55	796	12	17	412	146
Ideal Flow (vphpl)	1800	1800	1800	1800	1800	1800	1800	1800	1800	1800	1800	1800
Storage Length (m)	40.0		50.0	30.0		0.0	50.0		45.0	50.0		90.0
Storage Lanes	1		0	1		0	1		1	1		1
Taper Length (m)	20.0			5.0			10.0			10.0		
Lane Util. Factor	1.00	1.00	1.00	1.00	1.00	1.00	1.00	0.95	1.00	1.00	0.95	1.00
Frt		0.850			0.850				0.850			0.850
Flt Protected	0.950			0.950			0.950			0.950		
Satd. Flow (prot)	1330	1163	0	1101	998	0	1530	2956	1547	1320	2906	1357
Flt Permitted	0.750			0.738			0.488			0.307		
Satd. Flow (perm)	1050	1163	0	856	998	0	786	2956	1547	427	2906	1357
Right Turn on Red			Yes			Yes			Yes			Yes
Satd. Flow (RTOR)		408			158				40			162
Link Speed (k/h)		50			50			70			70	
Link Distance (m)		261.3			186.8			133.3			189.1	
Travel Time (s)		18.8			13.4			6.9			9.7	
Peak Hour Factor	0.90	0.90	0.90	0.90	0.90	0.90	0.90	0.90	0.90	0.90	0.90	0.90
Heavy Vehicles (%)	30%	2%	33%	57%	2%	55%	13%	17%	0%	31%	19%	14%
Adj. Flow (vph)	93	0	30	8	0	12	61	884	13	19	458	162
Shared Lane Traffic (%)												
Lane Group Flow (vph)	93	30	0	8	12	0	61	884	13	19	458	162
Enter Blocked Intersection	No	No	No	No	No	No	No	No	No	No	No	No
Lane Alignment	Left	Left	Right	Left	Left	Right	Left	Left	Right	Left	Left	Right
Median Width(m)		3.7			3.7			3.7			3.7	
Link Offset(m)		0.0			0.0			0.0			0.0	
Crosswalk Width(m)		4.9			4.9			4.9			4.9	
Two way Left Turn Lane								Yes			Yes	
Headway Factor	1.06	1.06	1.06	1.06	1.06	1.06	1.06	1.06	1.06	1.06	1.06	1.06
Turning Speed (k/h)	24		14	24		14	24		14	24		14
Number of Detectors	1	2		1	2		1	2	1	1	2	1
Detector Template	Left	Thru		Left	Thru		Left	Thru	Right	Left	Thru	Right
Leading Detector (m)	6.1	30.5		6.1	30.5		6.1	30.5	6.1	6.1	30.5	6.1
Trailing Detector (m)	0.0	0.0		0.0	0.0		0.0	0.0	0.0	0.0	0.0	0.0
Detector 1 Position(m)	0.0	0.0		0.0	0.0		0.0	0.0	0.0	0.0	0.0	0.0
Detector 1 Size(m)	6.1	1.8		6.1	1.8		6.1	1.8	6.1	6.1	1.8	6.1
Detector 1 Type	Cl+Ex	Cl+Ex		Cl+Ex	Cl+Ex		Cl+Ex	Cl+Ex	Cl+Ex	Cl+Ex	Cl+Ex	Cl+Ex
Detector 1 Channel												
Detector 1 Extend (s)	0.0	0.0		0.0	0.0		0.0	0.0	0.0	0.0	0.0	0.0
Detector 1 Queue (s)	0.0	0.0		0.0	0.0		0.0	0.0	0.0	0.0	0.0	0.0
Detector 1 Delay (s)	0.0	0.0		0.0	0.0		0.0	0.0	0.0	0.0	0.0	0.0
Detector 2 Position(m)		28.7			28.7			28.7			28.7	
Detector 2 Size(m)		1.8			1.8			1.8			1.8	
Detector 2 Type		Cl+Ex			Cl+Ex			Cl+Ex			Cl+Ex	
Detector 2 Channel												
Detector 2 Extend (s)		0.0			0.0			0.0			0.0	
Turn Type	Perm	NA		Perm	NA		Perm	NA	Perm	Perm	NA	Perm
Protected Phases		4			8			2			6	













Lanes, Volumes, Timings
2: Hawthorne Road & Site Access

2021 AM Existing Conditions

						
Lane Group	WBL	WBR	NBT	NBR	SBL	SBT
Lane Configurations			 			 
Traffic Volume (vph)	1	2	861	1	3	443
Future Volume (vph)	1	2	861	1	3	443
Ideal Flow (vphpl)	1900	1900	1900	1900	1900	1900
Storage Length (m)	0.0	0.0		0.0	20.0	
Storage Lanes	1	0		0	1	
Taper Length (m)	2.5				10.0	
Lane Util. Factor	1.00	1.00	0.95	0.95	1.00	0.95
Frt	0.910					
Flt Protected	0.984				0.950	
Satd. Flow (prot)	1462	0	3120	0	1534	3067
Flt Permitted	0.984				0.950	
Satd. Flow (perm)	1462	0	3120	0	1534	3067
Link Speed (k/h)	50		70			70
Link Distance (m)	106.8		135.2			133.3
Travel Time (s)	7.7		7.0			6.9
Peak Hour Factor	0.90	0.90	0.90	0.90	0.90	0.90
Heavy Vehicles (%)	19%	17%	17%	17%	19%	19%
Adj. Flow (vph)	1	2	957	1	3	492
Shared Lane Traffic (%)						
Lane Group Flow (vph)	3	0	958	0	3	492
Enter Blocked Intersection	No	No	No	No	No	No
Lane Alignment	Left	Right	Left	Right	Left	Left
Median Width(m)	3.7		3.7			3.7
Link Offset(m)	0.0		0.0			0.0
Crosswalk Width(m)	1.6		1.6			1.6
Two way Left Turn Lane			Yes			Yes
Headway Factor	0.99	0.99	0.99	0.99	0.99	0.99
Turning Speed (k/h)	24	14		14	24	
Sign Control	Stop		Free			Free
Intersection Summary						
Area Type:	Other					
Control Type:	Unsignalized					
Intersection Capacity Utilization	33.8%			ICU Level of Service A		
Analysis Period (min)	15					

HCM Unsignalized Intersection Capacity Analysis
2: Hawthorne Road & Site Access

2021 AM Existing Conditions

						
Movement	WBL	WBR	NBT	NBR	SBL	SBT
Lane Configurations			 			 
Traffic Volume (veh/h)	1	2	861	1	3	443
Future Volume (Veh/h)	1	2	861	1	3	443
Sign Control	Stop		Free			Free
Grade	0%		0%			0%
Peak Hour Factor	0.90	0.90	0.90	0.90	0.90	0.90
Hourly flow rate (vph)	1	2	957	1	3	492
Pedestrians						
Lane Width (m)						
Walking Speed (m/s)						
Percent Blockage						
Right turn flare (veh)						
Median type			TWLTL			TWLTL
Median storage veh			2			2
Upstream signal (m)						133
pX, platoon unblocked	0.97					
vC, conflicting volume	1210	479			958	
vC1, stage 1 conf vol	958					
vC2, stage 2 conf vol	252					
vCu, unblocked vol	1153	479			958	
tC, single (s)	7.2	7.2			4.5	
tC, 2 stage (s)	6.2					
tF (s)	3.7	3.5			2.4	
p0 queue free %	100	100			100	
cM capacity (veh/h)	284	494			618	
Direction, Lane #	WB 1	NB 1	NB 2	SB 1	SB 2	SB 3
Volume Total	3	638	320	3	246	246
Volume Left	1	0	0	3	0	0
Volume Right	2	0	1	0	0	0
cSH	396	1700	1700	618	1700	1700
Volume to Capacity	0.01	0.38	0.19	0.00	0.14	0.14
Queue Length 95th (m)	0.2	0.0	0.0	0.1	0.0	0.0
Control Delay (s)	14.2	0.0	0.0	10.9	0.0	0.0
Lane LOS	B			B		
Approach Delay (s)	14.2	0.0		0.1		
Approach LOS	B					
Intersection Summary						
Average Delay			0.1			
Intersection Capacity Utilization			33.8%		ICU Level of Service	A
Analysis Period (min)			15			

Intersection: 1: Hawthorne Road & Ages Drive

Movement	EB	EB	WB	WB	NB	NB	NB	NB	SB	SB	SB	SB
Directions Served	L	TR	L	TR	L	T	T	R	L	T	T	R
Maximum Queue (m)	42.9	13.9	8.5	12.8	16.6	40.0	25.6	2.6	9.0	28.5	11.4	6.0
Average Queue (m)	24.0	3.5	2.0	2.6	4.7	17.2	7.4	0.2	1.3	12.6	3.0	0.9
95th Queue (m)	45.9	27.1	10.1	11.2	13.6	35.8	24.6	1.8	7.1	28.9	10.5	6.7
Link Distance (m)		246.6		169.3		117.6	117.6			176.6	176.6	
Upstream Blk Time (%)												
Queuing Penalty (veh)												
Storage Bay Dist (m)	40.0		30.0		50.0			45.0	50.0			90.0
Storage Blk Time (%)	3					0	0					
Queuing Penalty (veh)	1					0	0					

Intersection: 2: Hawthorne Road & Site Access























Movement	WB	SB
Directions Served	LR	L
Maximum Queue (m)	6.8	3.5
Average Queue (m)	0.9	0.5
95th Queue (m)	5.3	3.8
Link Distance (m)	95.4	
Upstream Blk Time (%)		
Queuing Penalty (veh)		
Storage Bay Dist (m)	20.0	
Storage Blk Time (%)		
Queuing Penalty (veh)		

Network Summary

Network wide Queuing Penalty: 1

Lanes, Volumes, Timings
1: Hawthorne Road & Ages Drive

2021 PM Existing Conditions

												
Lane Group	EBL	EBT	EBR	WBL	WBT	WBR	NBL	NBT	NBR	SBL	SBT	SBR
Lane Configurations												
Traffic Volume (vph)	187	0	70	10	0	19	35	548	8	17	880	144
Future Volume (vph)	187	0	70	10	0	19	35	548	8	17	880	144
Ideal Flow (vphpl)	1800	1800	1800	1800	1800	1800	1800	1800	1800	1800	1800	1800
Storage Length (m)	40.0		50.0	30.0		0.0	50.0		45.0	50.0		90.0
Storage Lanes	1		0	1		0	1		1	1		1
Taper Length (m)	10.0			5.0			10.0			10.0		
Lane Util. Factor	1.00	1.00	1.00	1.00	1.00	1.00	1.00	0.95	1.00	1.00	0.95	1.00
Frt		0.850			0.850				0.850			0.850
Flt Protected	0.950			0.950			0.950			0.950		
Satd. Flow (prot)	1662	1488	0	1441	1394	0	1478	3087	1369	1465	3144	1146
Flt Permitted	0.744			0.706			0.251			0.408		
Satd. Flow (perm)	1302	1488	0	1071	1394	0	390	3087	1369	629	3144	1146
Right Turn on Red			Yes			Yes			Yes			Yes
Satd. Flow (RTOR)		137			306				38			160
Link Speed (k/h)		50			50			70			70	
Link Distance (m)		261.3			186.8			133.3			189.1	
Travel Time (s)		18.8			13.4			6.9			9.7	
Peak Hour Factor	0.90	0.90	0.90	0.90	0.90	0.90	0.90	0.90	0.90	0.90	0.90	0.90
Heavy Vehicles (%)	4%	2%	4%	20%	2%	11%	17%	12%	13%	18%	10%	35%
Adj. Flow (vph)	208	0	78	11	0	21	39	609	9	19	978	160
Shared Lane Traffic (%)												
Lane Group Flow (vph)	208	78	0	11	21	0	39	609	9	19	978	160
Enter Blocked Intersection	No	No	No	No	No	No	No	No	No	No	No	No
Lane Alignment	Left	Left	Right	Left	Left	Right	Left	Left	Right	Left	Left	Right
Median Width(m)		3.7			3.7			3.7			3.7	
Link Offset(m)		0.0			0.0			0.0			0.0	
Crosswalk Width(m)		4.9			4.9			4.9			4.9	
Two way Left Turn Lane								Yes			Yes	
Headway Factor	1.06	1.06	1.06	1.06	1.06	1.06	1.06	1.06	1.06	1.06	1.06	1.06
Turning Speed (k/h)	24		14	24		14	24		14	24		14
Turn Type	Perm	NA		Perm	NA		Perm	NA	Perm	Perm	NA	Perm
Protected Phases		4			8			2			6	
Permitted Phases	4			8			2		2	6		6
Minimum Split (s)	29.3	29.3		29.3	29.3		32.9	32.9	32.9	32.9	32.9	32.9
Total Split (s)	30.0	30.0		30.0	30.0		65.0	65.0	65.0	65.0	65.0	65.0
Total Split (%)	31.6%	31.6%		31.6%	31.6%		68.4%	68.4%	68.4%	68.4%	68.4%	68.4%
Maximum Green (s)	23.7	23.7		23.7	23.7		59.1	59.1	59.1	59.1	59.1	59.1
Yellow Time (s)	3.3	3.3		3.3	3.3		4.2	4.2	4.2	4.2	4.2	4.2
All-Red Time (s)	3.0	3.0		3.0	3.0		1.7	1.7	1.7	1.7	1.7	1.7
Lost Time Adjust (s)	0.0	0.0		0.0	0.0		0.0	0.0	0.0	0.0	0.0	0.0
Total Lost Time (s)	6.3	6.3		6.3	6.3		5.9	5.9	5.9	5.9	5.9	5.9
Lead/Lag												
Lead-Lag Optimize?												
Walk Time (s)	7.0	7.0		7.0	7.0		7.0	7.0	7.0	7.0	7.0	7.0
Flash Dont Walk (s)	16.0	16.0		16.0	16.0		20.0	20.0	20.0	20.0	20.0	20.0
Pedestrian Calls (#/hr)	0	0		0	0		0	0	0	0	0	0
Act Effct Green (s)	23.7	23.7		23.7	23.7		59.1	59.1	59.1	59.1	59.1	59.1
Actuated g/C Ratio	0.25	0.25		0.25	0.25		0.62	0.62	0.62	0.62	0.62	0.62

Lanes, Volumes, Timings
1: Hawthorne Road & Ages Drive

2021 PM Existing Conditions

Lane Group	EBL	EBT	EBR	WBL	WBT	WBR	NBL	NBT	NBR	SBL	SBT	SBR
v/c Ratio	0.64	0.16		0.04	0.04		0.16	0.32	0.01	0.05	0.50	0.21
Control Delay	42.3	1.5		27.7	0.1		9.6	9.0	0.0	7.5	10.9	1.9
Queue Delay	0.0	0.0		0.0	0.0		0.0	0.0	0.0	0.0	0.0	0.0
Total Delay	42.3	1.5		27.7	0.1		9.6	9.0	0.0	7.5	10.9	1.9
LOS	D	A		C	A		A	A	A	A	B	A
Approach Delay		31.1			9.6			8.9			9.6	
Approach LOS		C			A			A			A	

Intersection Summary













Area Type:	Other
Cycle Length:	95
Actuated Cycle Length:	95
Offset:	48 (51%), Referenced to phase 2:NBTL, Start of Green
Natural Cycle:	65
Control Type:	Pretimed
Maximum v/c Ratio:	0.64
Intersection Signal Delay:	12.3
Intersection LOS:	B
Intersection Capacity Utilization	58.5%
ICU Level of Service	B
Analysis Period (min)	15

Splits and Phases: 1: Hawthorne Road & Ages Drive















Lanes, Volumes, Timings
2: Hawthorne Road & Site Access

2021 PM Existing Conditions

						
Lane Group	WBL	WBR	NBT	NBR	SBL	SBT
Lane Configurations			 			 
Traffic Volume (vph)	2	4	587	2	4	956
Future Volume (vph)	2	4	587	2	4	956
Ideal Flow (vphpl)	1900	1900	1900	1900	1900	1900
Storage Length (m)	0.0	0.0		0.0	20.0	
Storage Lanes	1	0		0	1	
Taper Length (m)	2.5				10.0	
Lane Util. Factor	1.00	1.00	0.95	0.95	1.00	0.95
Frt	0.910					
Flt Protected	0.984				0.950	
Satd. Flow (prot)	1545	0	3259	0	1659	3318
Flt Permitted	0.984				0.950	
Satd. Flow (perm)	1545	0	3259	0	1659	3318
Link Speed (k/h)	50		70			70
Link Distance (m)	106.8		135.2			133.3
Travel Time (s)	7.7		7.0			6.9
Peak Hour Factor	0.90	0.90	0.90	0.90	0.90	0.90
Heavy Vehicles (%)	10%	12%	12%	12%	10%	10%
Adj. Flow (vph)	2	4	652	2	4	1062
Shared Lane Traffic (%)						
Lane Group Flow (vph)	6	0	654	0	4	1062
Enter Blocked Intersection	No	No	No	No	No	No
Lane Alignment	Left	Right	Left	Right	Left	Left
Median Width(m)	3.7		3.7			3.7
Link Offset(m)	0.0		0.0			0.0
Crosswalk Width(m)	1.6		1.6			1.6
Two way Left Turn Lane			Yes			Yes
Headway Factor	0.99	0.99	0.99	0.99	0.99	0.99
Turning Speed (k/h)	24	14		14	24	
Sign Control	Stop		Free			Free
Intersection Summary						
Area Type:	Other					
Control Type:	Unsignalized					
Intersection Capacity Utilization	36.4%			ICU Level of Service A		
Analysis Period (min)	15					

HCM Unsignalized Intersection Capacity Analysis
2: Hawthorne Road & Site Access

2021 PM Existing Conditions

						
Movement	WBL	WBR	NBT	NBR	SBL	SBT
Lane Configurations			 			 
Traffic Volume (veh/h)	2	4	587	2	4	956
Future Volume (Veh/h)	2	4	587	2	4	956
Sign Control	Stop		Free			Free
Grade	0%		0%			0%
Peak Hour Factor	0.90	0.90	0.90	0.90	0.90	0.90
Hourly flow rate (vph)	2	4	652	2	4	1062
Pedestrians						
Lane Width (m)						
Walking Speed (m/s)						
Percent Blockage						
Right turn flare (veh)						
Median type			TWLTL			TWLTL
Median storage veh			2			2
Upstream signal (m)						133
pX, platoon unblocked	0.84					
vC, conflicting volume	1192	327			654	
vC1, stage 1 conf vol	653					
vC2, stage 2 conf vol	539					
vCu, unblocked vol	837	327			654	
tC, single (s)	7.0	7.1			4.3	
tC, 2 stage (s)	6.0					
tF (s)	3.6	3.4			2.3	
p0 queue free %	100	99			100	
cM capacity (veh/h)	426	640			877	
Direction, Lane #	WB 1	NB 1	NB 2	SB 1	SB 2	SB 3
Volume Total	6	435	219	4	531	531
Volume Left	2	0	0	4	0	0
Volume Right	4	0	2	0	0	0
cSH	548	1700	1700	877	1700	1700
Volume to Capacity	0.01	0.26	0.13	0.00	0.31	0.31
Queue Length 95th (m)	0.3	0.0	0.0	0.1	0.0	0.0
Control Delay (s)	11.6	0.0	0.0	9.1	0.0	0.0
Lane LOS	B		A			
Approach Delay (s)	11.6	0.0	0.0			
Approach LOS	B					
Intersection Summary						
Average Delay			0.1			
Intersection Capacity Utilization			36.4%	ICU Level of Service	A	
Analysis Period (min)			15			

Intersection: 1: Hawthorne Road & Ages Drive

Movement	EB	EB	WB	WB	NB	NB	NB	NB	SB	SB	SB
Directions Served	L	TR	L	TR	L	T	T	R	L	T	T
Maximum Queue (m)	45.2	38.1	7.3	11.9	15.5	37.5	29.3	3.9	19.9	65.4	48.5
Average Queue (m)	29.8	5.9	2.2	3.5	4.9	23.9	12.7	0.6	4.3	42.2	24.0
95th Queue (m)	50.9	35.8	9.9	11.4	14.6	38.4	31.4	4.5	20.7	69.2	52.8
Link Distance (m)		246.6		169.3		117.6	117.6			176.6	176.6
Upstream Blk Time (%)											
Queuing Penalty (veh)											
Storage Bay Dist (m)	40.0		30.0		50.0			45.0	50.0		
Storage Blk Time (%)	7							0		3	
Queuing Penalty (veh)	5							0		0	

Intersection: 2: Hawthorne Road & Site Access























Movement	WB	SB
Directions Served	LR	L
Maximum Queue (m)	3.4	1.6
Average Queue (m)	1.0	0.2
95th Queue (m)	5.4	2.5
Link Distance (m)	95.4	
Upstream Blk Time (%)		
Queuing Penalty (veh)		
Storage Bay Dist (m)		20.0
Storage Blk Time (%)		
Queuing Penalty (veh)		

Network Summary

Network wide Queuing Penalty: 5

Lanes, Volumes, Timings
1: Hawthorne Road & Ages Drive

2026 AM Future Background

												
Lane Group	EBL	EBT	EBR	WBL	WBT	WBR	NBL	NBT	NBR	SBL	SBT	SBR
Lane Configurations												
Traffic Volume (vph)	84	0	27	7	0	11	55	872	12	17	467	146
Future Volume (vph)	84	0	27	7	0	11	55	872	12	17	467	146
Ideal Flow (vphpl)	1800	1800	1800	1800	1800	1800	1800	1800	1800	1800	1800	1800
Storage Length (m)	40.0		50.0	30.0		0.0	50.0		45.0	50.0		90.0
Storage Lanes	1		0	1		0	1		1	1		1
Taper Length (m)	20.0			5.0			10.0			10.0		
Lane Util. Factor	1.00	1.00	1.00	1.00	1.00	1.00	1.00	0.95	1.00	1.00	0.95	1.00
Frt		0.850			0.850				0.850			0.850
Flt Protected	0.950			0.950			0.950			0.950		
Satd. Flow (prot)	1330	1163	0	1101	998	0	1530	2956	1547	1320	2906	1357
Flt Permitted	0.750			0.740			0.484			0.313		
Satd. Flow (perm)	1050	1163	0	858	998	0	780	2956	1547	435	2906	1357
Right Turn on Red			Yes			Yes			Yes			Yes
Satd. Flow (RTOR)		400			162				40			146
Link Speed (k/h)		50			50			70				70
Link Distance (m)		261.3			186.8			133.3				189.1
Travel Time (s)		18.8			13.4			6.9				9.7
Peak Hour Factor	1.00	1.00	1.00	1.00	1.00	1.00	1.00	1.00	1.00	1.00	1.00	1.00
Heavy Vehicles (%)	30%	2%	33%	57%	2%	55%	13%	17%	0%	31%	19%	14%
Adj. Flow (vph)	84	0	27	7	0	11	55	872	12	17	467	146
Shared Lane Traffic (%)												
Lane Group Flow (vph)	84	27	0	7	11	0	55	872	12	17	467	146
Enter Blocked Intersection	No	No	No	No	No	No	No	No	No	No	No	No
Lane Alignment	Left	Left	Right	Left	Left	Right	Left	Left	Right	Left	Left	Right
Median Width(m)		3.7			3.7			3.7				3.7
Link Offset(m)		0.0			0.0			0.0				0.0
Crosswalk Width(m)		4.9			4.9			4.9				4.9
Two way Left Turn Lane								Yes				Yes
Headway Factor	1.06	1.06	1.06	1.06	1.06	1.06	1.06	1.06	1.06	1.06	1.06	1.06
Turning Speed (k/h)	24		14	24		14	24		14	24		14
Number of Detectors	1	2		1	2		1	2	1	1	2	1
Detector Template	Left	Thru		Left	Thru		Left	Thru	Right	Left	Thru	Right
Leading Detector (m)	6.1	30.5		6.1	30.5		6.1	30.5	6.1	6.1	30.5	6.1
Trailing Detector (m)	0.0	0.0		0.0	0.0		0.0	0.0	0.0	0.0	0.0	0.0
Detector 1 Position(m)	0.0	0.0		0.0	0.0		0.0	0.0	0.0	0.0	0.0	0.0
Detector 1 Size(m)	6.1	1.8		6.1	1.8		6.1	1.8	6.1	6.1	1.8	6.1
Detector 1 Type	Cl+Ex	Cl+Ex		Cl+Ex	Cl+Ex		Cl+Ex	Cl+Ex	Cl+Ex	Cl+Ex	Cl+Ex	Cl+Ex
Detector 1 Channel												
Detector 1 Extend (s)	0.0	0.0		0.0	0.0		0.0	0.0	0.0	0.0	0.0	0.0
Detector 1 Queue (s)	0.0	0.0		0.0	0.0		0.0	0.0	0.0	0.0	0.0	0.0
Detector 1 Delay (s)	0.0	0.0		0.0	0.0		0.0	0.0	0.0	0.0	0.0	0.0
Detector 2 Position(m)		28.7			28.7			28.7				28.7
Detector 2 Size(m)		1.8			1.8			1.8				1.8
Detector 2 Type		Cl+Ex			Cl+Ex			Cl+Ex				Cl+Ex
Detector 2 Channel												
Detector 2 Extend (s)		0.0			0.0			0.0				0.0
Turn Type	Perm	NA		Perm	NA		Perm	NA	Perm	Perm	NA	Perm
Protected Phases		4			8			2				6

Lanes, Volumes, Timings
1: Hawthorne Road & Ages Drive

2026 AM Future Background



Lane Group	EBL	EBT	EBR	WBL	WBT	WBR	NBL	NBT	NBR	SBL	SBT	SBR
Permitted Phases	4			8			2		2	6		6
Detector Phase	4	4		8	8		2	2	2	6	6	6
Switch Phase												
Minimum Initial (s)	5.0	5.0		5.0	5.0		5.0	5.0	5.0	5.0	5.0	5.0
Minimum Split (s)	29.3	29.3		29.3	29.3		32.9	32.9	32.9	32.9	32.9	32.9
Total Split (s)	30.0	30.0		30.0	30.0		60.0	60.0	60.0	60.0	60.0	60.0
Total Split (%)	33.3%	33.3%		33.3%	33.3%		66.7%	66.7%	66.7%	66.7%	66.7%	66.7%
Maximum Green (s)	23.7	23.7		23.7	23.7		54.1	54.1	54.1	54.1	54.1	54.1
Yellow Time (s)	3.3	3.3		3.3	3.3		4.2	4.2	4.2	4.2	4.2	4.2
All-Red Time (s)	3.0	3.0		3.0	3.0		1.7	1.7	1.7	1.7	1.7	1.7
Lost Time Adjust (s)	0.0	0.0		0.0	0.0		0.0	0.0	0.0	0.0	0.0	0.0
Total Lost Time (s)	6.3	6.3		6.3	6.3		5.9	5.9	5.9	5.9	5.9	5.9
Lead/Lag												
Lead-Lag Optimize?												
Vehicle Extension (s)	3.0	3.0		3.0	3.0		3.0	3.0	3.0	3.0	3.0	3.0
Recall Mode	Min	Min		Min	Min		C-Max	C-Max	C-Max	Max	Max	Max
Walk Time (s)	7.0	7.0		7.0	7.0		7.0	7.0	7.0	7.0	7.0	7.0
Flash Dont Walk (s)	16.0	16.0		16.0	16.0		20.0	20.0	20.0	20.0	20.0	20.0
Pedestrian Calls (#/hr)	0	0		0	0		0	0	0	0	0	0
Act Effct Green (s)	12.5	12.5		12.5	12.5		65.3	65.3	65.3	65.3	65.3	65.3
Actuated g/C Ratio	0.14	0.14		0.14	0.14		0.73	0.73	0.73	0.73	0.73	0.73
v/c Ratio	0.58	0.05		0.06	0.04		0.10	0.41	0.01	0.05	0.22	0.14
Control Delay	50.7	0.2		31.6	0.3		5.2	6.1	0.0	5.4	4.9	1.3
Queue Delay	0.0	0.0		0.0	0.0		0.0	0.0	0.0	0.0	0.0	0.0
Total Delay	50.7	0.2		31.6	0.3		5.2	6.1	0.0	5.4	4.9	1.3
LOS	D	A		C	A		A	A	A	A	A	A
Approach Delay		38.4			12.4			5.9			4.1	
Approach LOS		D			B			A			A	

Intersection Summary





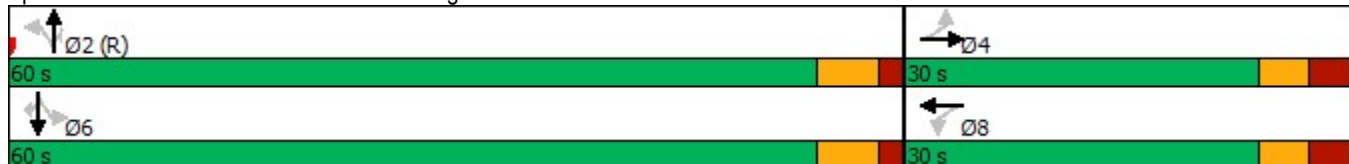







Area Type:	Other
Cycle Length:	90
Actuated Cycle Length:	90
Offset:	70 (78%), Referenced to phase 2:NBTL, Start of Green
Natural Cycle:	65
Control Type:	Actuated-Coordinated
Maximum v/c Ratio:	0.58
Intersection Signal Delay:	7.4
Intersection LOS:	A
Intersection Capacity Utilization	56.3%
ICU Level of Service	B
Analysis Period (min)	15

Splits and Phases: 1: Hawthorne Road & Ages Drive















Lanes, Volumes, Timings
2: Hawthorne Road & Site Access

2026 AM Future Background

						
Lane Group	WBL	WBR	NBT	NBR	SBL	SBT
Lane Configurations			 			 
Traffic Volume (vph)	1	2	937	1	3	498
Future Volume (vph)	1	2	937	1	3	498
Ideal Flow (vphpl)	1900	1900	1900	1900	1900	1900
Storage Length (m)	0.0	0.0		0.0	20.0	
Storage Lanes	1	0		0	1	
Taper Length (m)	2.5				10.0	
Lane Util. Factor	1.00	1.00	0.95	0.95	1.00	0.95
Frt	0.910					
Flt Protected	0.984				0.950	
Satd. Flow (prot)	1462	0	3120	0	1534	3067
Flt Permitted	0.984				0.950	
Satd. Flow (perm)	1462	0	3120	0	1534	3067
Link Speed (k/h)	50		70			70
Link Distance (m)	106.8		135.2			133.3
Travel Time (s)	7.7		7.0			6.9
Peak Hour Factor	1.00	1.00	1.00	1.00	1.00	1.00
Heavy Vehicles (%)	19%	17%	17%	17%	19%	19%
Adj. Flow (vph)	1	2	937	1	3	498
Shared Lane Traffic (%)						
Lane Group Flow (vph)	3	0	938	0	3	498
Enter Blocked Intersection	No	No	No	No	No	No
Lane Alignment	Left	Right	Left	Right	Left	Left
Median Width(m)	3.7		3.7			3.7
Link Offset(m)	0.0		0.0			0.0
Crosswalk Width(m)	1.6		1.6			1.6
Two way Left Turn Lane			Yes			Yes
Headway Factor	0.99	0.99	0.99	0.99	0.99	0.99
Turning Speed (k/h)	24	14		14	24	
Sign Control	Stop		Free			Free
Intersection Summary						
Area Type:	Other					
Control Type:	Unsignalized					
Intersection Capacity Utilization	35.9%			ICU Level of Service A		
Analysis Period (min)	15					

HCM Unsignalized Intersection Capacity Analysis
2: Hawthorne Road & Site Access

2026 AM Future Background

						
Movement	WBL	WBR	NBT	NBR	SBL	SBT
Lane Configurations			 			 
Traffic Volume (veh/h)	1	2	937	1	3	498
Future Volume (Veh/h)	1	2	937	1	3	498
Sign Control	Stop		Free			Free
Grade	0%		0%			0%
Peak Hour Factor	1.00	1.00	1.00	1.00	1.00	1.00
Hourly flow rate (vph)	1	2	937	1	3	498
Pedestrians						
Lane Width (m)						
Walking Speed (m/s)						
Percent Blockage						
Right turn flare (veh)						
Median type	TWLTL			TWLTL		
Median storage veh	2			2		
Upstream signal (m)				133		
pX, platoon unblocked	0.97					
vC, conflicting volume	1192	469	938			
vC1, stage 1 conf vol	938					
vC2, stage 2 conf vol	255					
vCu, unblocked vol	1136	469	938			
tC, single (s)	7.2	7.2	4.5			
tC, 2 stage (s)	6.2					
tF (s)	3.7	3.5	2.4			
p0 queue free %	100	100	100			
cM capacity (veh/h)	291	502	630			
Direction, Lane #	WB 1	NB 1	NB 2	SB 1	SB 2	SB 3
Volume Total	3	625	313	3	249	249
Volume Left	1	0	0	3	0	0
Volume Right	2	0	1	0	0	0
cSH	404	1700	1700	630	1700	1700
Volume to Capacity	0.01	0.37	0.18	0.00	0.15	0.15
Queue Length 95th (m)	0.2	0.0	0.0	0.1	0.0	0.0
Control Delay (s)	14.0	0.0	0.0	10.7	0.0	0.0
Lane LOS	B				B	
Approach Delay (s)	14.0	0.0	0.1			
Approach LOS	B					
Intersection Summary						
Average Delay	0.1					
Intersection Capacity Utilization	35.9%			ICU Level of Service	A	
Analysis Period (min)	15					

Intersection: 1: Hawthorne Road & Ages Drive

Movement	EB	WB	WB	NB	NB	NB	NB	SB	SB	SB	SB
Directions Served	L	L	TR	L	T	T	R	L	T	T	R
Maximum Queue (m)	36.9	13.4	12.5	13.1	36.5	27.7	4.9	11.8	29.7	13.9	3.4
Average Queue (m)	21.5	1.6	3.3	5.3	20.4	11.3	0.7	3.2	13.7	4.9	0.5
95th Queue (m)	39.8	10.1	12.1	14.5	38.8	27.6	3.8	10.6	30.8	14.4	5.1
Link Distance (m)			169.3		117.6	117.6			176.6	176.6	
Upstream Blk Time (%)											
Queuing Penalty (veh)											
Storage Bay Dist (m)	40.0	30.0		50.0			45.0	50.0			90.0
Storage Blk Time (%)	1	0			0						
Queuing Penalty (veh)	0	0			0						

Intersection: 2: Hawthorne Road & Site Access























Movement	WB	SB
Directions Served	LR	L
Maximum Queue (m)	3.4	1.8
Average Queue (m)	0.5	0.3
95th Queue (m)	3.8	2.7
Link Distance (m)	95.4	
Upstream Blk Time (%)		
Queuing Penalty (veh)		
Storage Bay Dist (m)		20.0
Storage Blk Time (%)		
Queuing Penalty (veh)		

Network Summary

Network wide Queuing Penalty: 0

Lanes, Volumes, Timings
1: Hawthorne Road & Ages Drive

2026 PM Future Background

												
Lane Group	EBL	EBT	EBR	WBL	WBT	WBR	NBL	NBT	NBR	SBL	SBT	SBR
Lane Configurations												
Traffic Volume (vph)	187	0	70	10	0	19	35	621	8	17	948	144
Future Volume (vph)	187	0	70	10	0	19	35	621	8	17	948	144
Ideal Flow (vphpl)	1800	1800	1800	1800	1800	1800	1800	1800	1800	1800	1800	1800
Storage Length (m)	40.0		50.0	30.0		0.0	50.0		45.0	50.0		90.0
Storage Lanes	1		0	1		0	1		1	1		1
Taper Length (m)	20.0			5.0			10.0			10.0		
Lane Util. Factor	1.00	1.00	1.00	1.00	1.00	1.00	1.00	0.95	1.00	1.00	0.95	1.00
Frt		0.850			0.850				0.850			0.850
Flt Protected	0.950			0.950			0.950			0.950		
Satd. Flow (prot)	1662	1488	0	1441	1394	0	1478	3087	1369	1465	3144	1146
Flt Permitted	0.745			0.711			0.262			0.402		
Satd. Flow (perm)	1304	1488	0	1078	1394	0	408	3087	1369	620	3144	1146
Right Turn on Red			Yes			Yes			Yes			Yes
Satd. Flow (RTOR)		147			299				38			144
Link Speed (k/h)		50			50			70			70	
Link Distance (m)		261.3			186.8			133.3			189.1	
Travel Time (s)		18.8			13.4			6.9			9.7	
Peak Hour Factor	1.00	1.00	1.00	1.00	1.00	1.00	1.00	1.00	1.00	1.00	1.00	1.00
Heavy Vehicles (%)	4%	2%	4%	20%	2%	11%	17%	12%	13%	18%	10%	35%
Adj. Flow (vph)	187	0	70	10	0	19	35	621	8	17	948	144
Shared Lane Traffic (%)												
Lane Group Flow (vph)	187	70	0	10	19	0	35	621	8	17	948	144
Enter Blocked Intersection	No	No	No	No	No	No	No	No	No	No	No	No
Lane Alignment	Left	Left	Right	Left	Left	Right	Left	Left	Right	Left	Left	Right
Median Width(m)		3.7			3.7			3.7			3.7	
Link Offset(m)		0.0			0.0			0.0			0.0	
Crosswalk Width(m)		4.9			4.9			4.9			4.9	
Two way Left Turn Lane								Yes			Yes	
Headway Factor	1.06	1.06	1.06	1.06	1.06	1.06	1.06	1.06	1.06	1.06	1.06	1.06
Turning Speed (k/h)	24		14	24		14	24		14	24		14
Turn Type	Perm	NA		Perm	NA		Perm	NA	Perm	Perm	NA	Perm
Protected Phases		4			8			2			6	
Permitted Phases	4			8			2		2	6		6
Minimum Split (s)	29.3	29.3		29.3	29.3		32.9	32.9	32.9	32.9	32.9	32.9
Total Split (s)	30.0	30.0		30.0	30.0		65.0	65.0	65.0	65.0	65.0	65.0
Total Split (%)	31.6%	31.6%		31.6%	31.6%		68.4%	68.4%	68.4%	68.4%	68.4%	68.4%
Maximum Green (s)	23.7	23.7		23.7	23.7		59.1	59.1	59.1	59.1	59.1	59.1
Yellow Time (s)	3.3	3.3		3.3	3.3		4.2	4.2	4.2	4.2	4.2	4.2
All-Red Time (s)	3.0	3.0		3.0	3.0		1.7	1.7	1.7	1.7	1.7	1.7
Lost Time Adjust (s)	0.0	0.0		0.0	0.0		0.0	0.0	0.0	0.0	0.0	0.0
Total Lost Time (s)	6.3	6.3		6.3	6.3		5.9	5.9	5.9	5.9	5.9	5.9
Lead/Lag												
Lead-Lag Optimize?												
Walk Time (s)	7.0	7.0		7.0	7.0		7.0	7.0	7.0	7.0	7.0	7.0
Flash Dont Walk (s)	16.0	16.0		16.0	16.0		20.0	20.0	20.0	20.0	20.0	20.0
Pedestrian Calls (#/hr)	0	0		0	0		0	0	0	0	0	0
Act Effct Green (s)	23.7	23.7		23.7	23.7		59.1	59.1	59.1	59.1	59.1	59.1
Actuated g/C Ratio	0.25	0.25		0.25	0.25		0.62	0.62	0.62	0.62	0.62	0.62

Lanes, Volumes, Timings
1: Hawthorne Road & Ages Drive

2026 PM Future Background







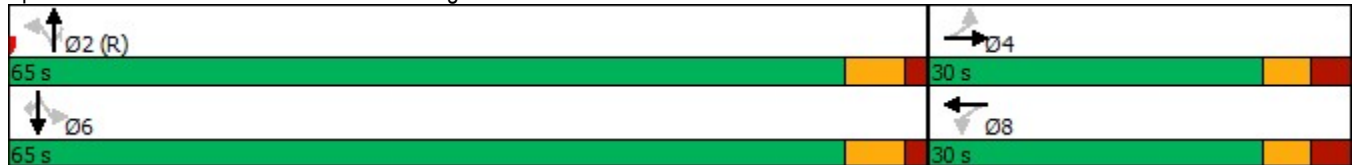





Lane Group	EBL	EBT	EBR	WBL	WBT	WBR	NBL	NBT	NBR	SBL	SBT	SBR
v/c Ratio	0.58	0.15		0.04	0.03		0.14	0.32	0.01	0.04	0.48	0.19
Control Delay	39.4	0.6		27.7	0.1		9.1	9.1	0.0	7.4	10.7	1.9
Queue Delay	0.0	0.0		0.0	0.0		0.0	0.0	0.0	0.0	0.0	0.0
Total Delay	39.4	0.6		27.7	0.1		9.1	9.1	0.0	7.4	10.7	1.9
LOS	D	A		C	A		A	A	A	A	B	A
Approach Delay		28.8			9.6			9.0			9.5	
Approach LOS		C			A			A			A	

Intersection Summary	
Area Type:	Other
Cycle Length:	95
Actuated Cycle Length:	95
Offset:	48 (51%), Referenced to phase 2:NBTL, Start of Green
Natural Cycle:	65
Control Type:	Pretimed
Maximum v/c Ratio:	0.58
Intersection Signal Delay:	11.8
Intersection LOS:	B
Intersection Capacity Utilization	58.5%
ICU Level of Service	B
Analysis Period (min)	15

Splits and Phases: 1: Hawthorne Road & Ages Drive













Lanes, Volumes, Timings
2: Hawthorne Road & Site Access

						
Lane Group	WBL	WBR	NBT	NBR	SBL	SBT
Lane Configurations			 			 
Traffic Volume (vph)	2	4	660	2	4	1024
Future Volume (vph)	2	4	660	2	4	1024
Ideal Flow (vphpl)	1900	1900	1900	1900	1900	1900
Storage Length (m)	0.0	0.0		0.0	20.0	
Storage Lanes	1	0		0	1	
Taper Length (m)	2.5				10.0	
Lane Util. Factor	1.00	1.00	0.95	0.95	1.00	0.95
Frt	0.910					
Flt Protected	0.984				0.950	
Satd. Flow (prot)	1545	0	3259	0	1659	3318
Flt Permitted	0.984				0.950	
Satd. Flow (perm)	1545	0	3259	0	1659	3318
Link Speed (k/h)	50		70			70
Link Distance (m)	106.8		135.2			133.3
Travel Time (s)	7.7		7.0			6.9
Peak Hour Factor	1.00	1.00	1.00	1.00	1.00	1.00
Heavy Vehicles (%)	10%	12%	12%	12%	10%	10%
Adj. Flow (vph)	2	4	660	2	4	1024
Shared Lane Traffic (%)						
Lane Group Flow (vph)	6	0	662	0	4	1024
Enter Blocked Intersection	No	No	No	No	No	No
Lane Alignment	Left	Right	Left	Right	Left	Left
Median Width(m)	3.7		3.7			3.7
Link Offset(m)	0.0		0.0			0.0
Crosswalk Width(m)	1.6		1.6			1.6
Two way Left Turn Lane			Yes			Yes
Headway Factor	0.99	0.99	0.99	0.99	0.99	0.99
Turning Speed (k/h)	24	14		14	24	
Sign Control	Stop		Free			Free
Intersection Summary						
Area Type:	Other					
Control Type:	Unsignalized					
Intersection Capacity Utilization	38.3%			ICU Level of Service A		
Analysis Period (min)	15					

HCM Unsignalized Intersection Capacity Analysis 2: Hawthorne Road & Site Access

2026 PM Future Background

						
Movement	WBL	WBR	NBT	NBR	SBL	SBT
Lane Configurations						
Traffic Volume (veh/h)	2	4	660	2	4	1024
Future Volume (Veh/h)	2	4	660	2	4	1024
Sign Control	Stop		Free			Free
Grade	0%		0%			0%
Peak Hour Factor	1.00	1.00	1.00	1.00	1.00	1.00
Hourly flow rate (vph)	2	4	660	2	4	1024
Pedestrians						
Lane Width (m)						
Walking Speed (m/s)						
Percent Blockage						
Right turn flare (veh)						
Median type	TWLTL			TWLTL		
Median storage veh	2			2		
Upstream signal (m)				133		
pX, platoon unblocked	0.84					
vC, conflicting volume	1181	331	662			
vC1, stage 1 conf vol	661					
vC2, stage 2 conf vol	520					
vCu, unblocked vol	844	331	662			
tC, single (s)	7.0	7.1	4.3			
tC, 2 stage (s)	6.0					
tF (s)	3.6	3.4	2.3			
p0 queue free %	100	99	100			
cM capacity (veh/h)	423	636	871			
Direction, Lane #	WB 1	NB 1	NB 2	SB 1	SB 2	SB 3
Volume Total	6	440	222	4	512	512
Volume Left	2	0	0	4	0	0
Volume Right	4	0	2	0	0	0
cSH	544	1700	1700	871	1700	1700
Volume to Capacity	0.01	0.26	0.13	0.00	0.30	0.30
Queue Length 95th (m)	0.3	0.0	0.0	0.1	0.0	0.0
Control Delay (s)	11.7	0.0	0.0	9.2	0.0	0.0
Lane LOS	B				A	
Approach Delay (s)	11.7	0.0	0.0			
Approach LOS	B					
Intersection Summary						
Average Delay			0.1			
Intersection Capacity Utilization			38.3%	ICU Level of Service	A	
Analysis Period (min)			15			

Intersection: 1: Hawthorne Road & Ages Drive

Movement	EB	EB	WB	WB	NB	NB	NB	NB	SB	SB	SB	SB
Directions Served	L	TR	L	TR	L	T	T	R	L	T	T	R
Maximum Queue (m)	44.9	6.6	8.3	7.3	17.8	40.4	32.8	4.1	10.3	64.9	51.2	4.7
Average Queue (m)	27.3	1.0	2.6	2.3	6.9	27.4	16.8	0.6	2.9	45.6	26.7	0.7
95th Queue (m)	46.9	7.3	11.2	8.5	19.3	45.3	37.9	4.7	9.3	73.0	55.7	5.5
Link Distance (m)		246.6		169.3		117.6	117.6			176.6	176.6	
Upstream Blk Time (%)												
Queuing Penalty (veh)												
Storage Bay Dist (m)	40.0		30.0		50.0			45.0	50.0			90.0
Storage Blk Time (%)	2					0	0			3		
Queuing Penalty (veh)	1					0	0			1		

Intersection: 2: Hawthorne Road & Site Access























Movement	WB	SB
Directions Served	LR	L
Maximum Queue (m)	5.2	1.8
Average Queue (m)	1.5	0.4
95th Queue (m)	6.7	3.3
Link Distance (m)	95.4	
Upstream Blk Time (%)		
Queuing Penalty (veh)		
Storage Bay Dist (m)	20.0	
Storage Blk Time (%)		
Queuing Penalty (veh)		

Network Summary

Network wide Queuing Penalty: 2

Lanes, Volumes, Timings
1: Hawthorne Road & Ages Drive

2026 AM Future Total

												
Lane Group	EBL	EBT	EBR	WBL	WBT	WBR	NBL	NBT	NBR	SBL	SBT	SBR
Lane Configurations												
Traffic Volume (vph)	84	0	27	7	0	11	55	876	12	17	473	146
Future Volume (vph)	84	0	27	7	0	11	55	876	12	17	473	146
Ideal Flow (vphpl)	1800	1800	1800	1800	1800	1800	1800	1800	1800	1800	1800	1800
Storage Length (m)	40.0		50.0	30.0		0.0	50.0		45.0	50.0		90.0
Storage Lanes	1		0	1		0	1		1	1		1
Taper Length (m)	20.0			5.0			10.0			10.0		
Lane Util. Factor	1.00	1.00	1.00	1.00	1.00	1.00	1.00	0.95	1.00	1.00	0.95	1.00
Frt		0.850			0.850				0.850			0.850
Flt Protected	0.950			0.950			0.950			0.950		
Satd. Flow (prot)	1330	1163	0	1101	998	0	1530	2956	1547	1320	2906	1357
Flt Permitted	0.750			0.740			0.481			0.311		
Satd. Flow (perm)	1050	1163	0	858	998	0	775	2956	1547	432	2906	1357
Right Turn on Red			Yes			Yes			Yes			Yes
Satd. Flow (RTOR)		395			161				40			146
Link Speed (k/h)		50			50			70				70
Link Distance (m)		261.3			186.8			133.3				189.1
Travel Time (s)		18.8			13.4			6.9				9.7
Peak Hour Factor	1.00	1.00	1.00	1.00	1.00	1.00	1.00	1.00	1.00	1.00	1.00	1.00
Heavy Vehicles (%)	30%	2%	33%	57%	2%	55%	13%	17%	0%	31%	19%	14%
Adj. Flow (vph)	84	0	27	7	0	11	55	876	12	17	473	146
Shared Lane Traffic (%)												
Lane Group Flow (vph)	84	27	0	7	11	0	55	876	12	17	473	146
Enter Blocked Intersection	No	No	No	No	No	No	No	No	No	No	No	No
Lane Alignment	Left	Left	Right	Left	Left	Right	Left	Left	Right	Left	Left	Right
Median Width(m)		3.7			3.7			3.7				3.7
Link Offset(m)		0.0			0.0			0.0				0.0
Crosswalk Width(m)		4.9			4.9			4.9				4.9
Two way Left Turn Lane								Yes				Yes
Headway Factor	1.06	1.06	1.06	1.06	1.06	1.06	1.06	1.06	1.06	1.06	1.06	1.06
Turning Speed (k/h)	24		14	24		14	24		14	24		14
Number of Detectors	1	2		1	2		1	2	1	1	2	1
Detector Template	Left	Thru		Left	Thru		Left	Thru	Right	Left	Thru	Right
Leading Detector (m)	6.1	30.5		6.1	30.5		6.1	30.5	6.1	6.1	30.5	6.1
Trailing Detector (m)	0.0	0.0		0.0	0.0		0.0	0.0	0.0	0.0	0.0	0.0
Detector 1 Position(m)	0.0	0.0		0.0	0.0		0.0	0.0	0.0	0.0	0.0	0.0
Detector 1 Size(m)	6.1	1.8		6.1	1.8		6.1	1.8	6.1	6.1	1.8	6.1
Detector 1 Type	Cl+Ex	Cl+Ex		Cl+Ex	Cl+Ex		Cl+Ex	Cl+Ex	Cl+Ex	Cl+Ex	Cl+Ex	Cl+Ex
Detector 1 Channel												
Detector 1 Extend (s)	0.0	0.0		0.0	0.0		0.0	0.0	0.0	0.0	0.0	0.0
Detector 1 Queue (s)	0.0	0.0		0.0	0.0		0.0	0.0	0.0	0.0	0.0	0.0
Detector 1 Delay (s)	0.0	0.0		0.0	0.0		0.0	0.0	0.0	0.0	0.0	0.0
Detector 2 Position(m)		28.7			28.7			28.7				28.7
Detector 2 Size(m)		1.8			1.8			1.8				1.8
Detector 2 Type		Cl+Ex			Cl+Ex			Cl+Ex				Cl+Ex
Detector 2 Channel												
Detector 2 Extend (s)		0.0			0.0			0.0				0.0
Turn Type	Perm	NA		Perm	NA		Perm	NA	Perm	Perm	NA	Perm
Protected Phases		4			8			2				6

Lanes, Volumes, Timings
1: Hawthorne Road & Ages Drive

2026 AM Future Total

Lane Group	EBL	EBT	EBR	WBL	WBT	WBR	NBL	NBT	NBR	SBL	SBT	SBR
Permitted Phases	4			8			2		2	6		6
Detector Phase	4	4		8	8		2	2	2	6	6	6
Switch Phase												
Minimum Initial (s)	5.0	5.0		5.0	5.0		5.0	5.0	5.0	5.0	5.0	5.0
Minimum Split (s)	29.3	29.3		29.3	29.3		32.9	32.9	32.9	32.9	32.9	32.9
Total Split (s)	30.0	30.0		30.0	30.0		60.0	60.0	60.0	60.0	60.0	60.0
Total Split (%)	33.3%	33.3%		33.3%	33.3%		66.7%	66.7%	66.7%	66.7%	66.7%	66.7%
Maximum Green (s)	23.7	23.7		23.7	23.7		54.1	54.1	54.1	54.1	54.1	54.1
Yellow Time (s)	3.3	3.3		3.3	3.3		4.2	4.2	4.2	4.2	4.2	4.2
All-Red Time (s)	3.0	3.0		3.0	3.0		1.7	1.7	1.7	1.7	1.7	1.7
Lost Time Adjust (s)	0.0	0.0		0.0	0.0		0.0	0.0	0.0	0.0	0.0	0.0
Total Lost Time (s)	6.3	6.3		6.3	6.3		5.9	5.9	5.9	5.9	5.9	5.9
Lead/Lag												
Lead-Lag Optimize?												
Vehicle Extension (s)	3.0	3.0		3.0	3.0		3.0	3.0	3.0	3.0	3.0	3.0
Recall Mode	Min	Min		Min	Min		C-Max	C-Max	C-Max	C-Max	C-Max	C-Max
Walk Time (s)	7.0	7.0		7.0	7.0		7.0	7.0	7.0	7.0	7.0	7.0
Flash Dont Walk (s)	16.0	16.0		16.0	16.0		20.0	20.0	20.0	20.0	20.0	20.0
Pedestrian Calls (#/hr)	0	0		0	0		0	0	0	0	0	0
Act Effct Green (s)	12.5	12.5		12.5	12.5		65.3	65.3	65.3	65.3	65.3	65.3
Actuated g/C Ratio	0.14	0.14		0.14	0.14		0.73	0.73	0.73	0.73	0.73	0.73
v/c Ratio	0.58	0.05		0.06	0.04		0.10	0.41	0.01	0.05	0.22	0.14
Control Delay	50.7	0.2		31.6	0.3		5.2	6.1	0.0	5.4	4.9	1.3
Queue Delay	0.0	0.0		0.0	0.0		0.0	0.0	0.0	0.0	0.0	0.0
Total Delay	50.7	0.2		31.6	0.3		5.2	6.1	0.0	5.4	4.9	1.3
LOS	D	A		C	A		A	A	A	A	A	A
Approach Delay		38.4			12.4			6.0				4.1
Approach LOS		D			B			A				A

Intersection Summary













Area Type: Other
 Cycle Length: 90
 Actuated Cycle Length: 90
 Offset: 70 (78%), Referenced to phase 2:NBTL and 6:SBTL, Start of Green
 Natural Cycle: 65
 Control Type: Actuated-Coordinated
 Maximum v/c Ratio: 0.58
 Intersection Signal Delay: 7.4 Intersection LOS: A
 Intersection Capacity Utilization 56.4% ICU Level of Service B
 Analysis Period (min) 15

Splits and Phases: 1: Hawthorne Road & Ages Drive















Lanes, Volumes, Timings
2: Hawthorne Road & Site Access

2026 AM Future Total

						
Lane Group	WBL	WBR	NBT	NBR	SBL	SBT
Lane Configurations			 			 
Traffic Volume (vph)	2	6	937	3	9	498
Future Volume (vph)	2	6	937	3	9	498
Ideal Flow (vphpl)	1900	1900	1900	1900	1900	1900
Storage Length (m)	0.0	0.0		0.0	20.0	
Storage Lanes	1	0		0	1	
Taper Length (m)	2.5				10.0	
Lane Util. Factor	1.00	1.00	0.95	0.95	1.00	0.95
Frt	0.899					
Flt Protected	0.988				0.950	
Satd. Flow (prot)	1452	0	3120	0	1534	3067
Flt Permitted	0.988				0.950	
Satd. Flow (perm)	1452	0	3120	0	1534	3067
Link Speed (k/h)	50		70			70
Link Distance (m)	106.8		135.2			133.3
Travel Time (s)	7.7		7.0			6.9
Peak Hour Factor	1.00	1.00	1.00	1.00	1.00	1.00
Heavy Vehicles (%)	19%	17%	17%	17%	19%	19%
Adj. Flow (vph)	2	6	937	3	9	498
Shared Lane Traffic (%)						
Lane Group Flow (vph)	8	0	940	0	9	498
Enter Blocked Intersection	No	No	No	No	No	No
Lane Alignment	Left	Right	Left	Right	Left	Left
Median Width(m)	3.7		3.7			3.7
Link Offset(m)	0.0		0.0			0.0
Crosswalk Width(m)	1.6		1.6			1.6
Two way Left Turn Lane			Yes			Yes
Headway Factor	0.99	0.99	0.99	0.99	0.99	0.99
Turning Speed (k/h)	24	14		14	24	
Sign Control	Stop		Free			Free
Intersection Summary						
Area Type:	Other					
Control Type:	Unsignalized					
Intersection Capacity Utilization	36.0%			ICU Level of Service A		
Analysis Period (min)	15					

HCM Unsignalized Intersection Capacity Analysis
2: Hawthorne Road & Site Access

2026 AM Future Total

						
Movement	WBL	WBR	NBT	NBR	SBL	SBT
Lane Configurations			 			 
Traffic Volume (veh/h)	2	6	937	3	9	498
Future Volume (Veh/h)	2	6	937	3	9	498
Sign Control	Stop		Free			Free
Grade	0%		0%			0%
Peak Hour Factor	1.00	1.00	1.00	1.00	1.00	1.00
Hourly flow rate (vph)	2	6	937	3	9	498
Pedestrians						
Lane Width (m)						
Walking Speed (m/s)						
Percent Blockage						
Right turn flare (veh)						
Median type	TWLTL			TWLTL		
Median storage veh	2			2		
Upstream signal (m)				133		
pX, platoon unblocked	0.97					
vC, conflicting volume	1206	470	940			
vC1, stage 1 conf vol	938					
vC2, stage 2 conf vol	267					
vCu, unblocked vol	1149	470	940			
tC, single (s)	7.2	7.2	4.5			
tC, 2 stage (s)	6.2					
tF (s)	3.7	3.5	2.4			
p0 queue free %	99	99	99			
cM capacity (veh/h)	290	501	629			
Direction, Lane #	WB 1	NB 1	NB 2	SB 1	SB 2	SB 3
Volume Total	8	625	315	9	249	249
Volume Left	2	0	0	9	0	0
Volume Right	6	0	3	0	0	0
cSH	424	1700	1700	629	1700	1700
Volume to Capacity	0.02	0.37	0.19	0.01	0.15	0.15
Queue Length 95th (m)	0.4	0.0	0.0	0.3	0.0	0.0
Control Delay (s)	13.7	0.0	0.0	10.8	0.0	0.0
Lane LOS	B				B	
Approach Delay (s)	13.7	0.0	0.2			
Approach LOS	B					
Intersection Summary						
Average Delay	0.1					
Intersection Capacity Utilization	36.0%			ICU Level of Service	A	
Analysis Period (min)	15					

Intersection: 1: Hawthorne Road & Ages Drive

Movement	EB	WB	WB	NB	NB	NB	NB	SB	SB	SB
Directions Served	L	L	TR	L	T	T	R	L	T	T
Maximum Queue (m)	34.5	5.6	16.0	20.3	37.1	26.6	4.0	10.8	30.8	14.9
Average Queue (m)	22.7	1.4	4.7	7.0	21.6	11.1	0.7	2.9	11.2	2.9
95th Queue (m)	37.5	8.1	16.2	18.7	38.4	26.6	4.2	10.4	25.5	10.4
Link Distance (m)			169.3		117.6	117.6			176.6	176.6
Upstream Blk Time (%)										
Queuing Penalty (veh)										
Storage Bay Dist (m)	40.0	30.0		50.0			45.0	50.0		
Storage Blk Time (%)	1		0		0	0			0	
Queuing Penalty (veh)	0		0		0	0			0	

Intersection: 2: Hawthorne Road & Site Access























Movement	WB	SB
Directions Served	LR	L
Maximum Queue (m)	6.1	4.9
Average Queue (m)	1.3	0.9
95th Queue (m)	6.9	5.3
Link Distance (m)	95.4	
Upstream Blk Time (%)		
Queuing Penalty (veh)		
Storage Bay Dist (m)		20.0
Storage Blk Time (%)		
Queuing Penalty (veh)		

Network Summary

Network wide Queuing Penalty: 0

Lanes, Volumes, Timings
1: Hawthorne Road & Ages Drive

2026 PM Future Total

												
Lane Group	EBL	EBT	EBR	WBL	WBT	WBR	NBL	NBT	NBR	SBL	SBT	SBR
Lane Configurations												
Traffic Volume (vph)	187	0	70	10	0	19	35	629	8	17	955	144
Future Volume (vph)	187	0	70	10	0	19	35	629	8	17	955	144
Ideal Flow (vphp)	1800	1800	1800	1800	1800	1800	1800	1800	1800	1800	1800	1800
Storage Length (m)	40.0		50.0	30.0		0.0	50.0		45.0	50.0		90.0
Storage Lanes	1		0	1		0	1		1	1		1
Taper Length (m)	20.0			5.0			10.0			10.0		
Lane Util. Factor	1.00	1.00	1.00	1.00	1.00	1.00	1.00	0.95	1.00	1.00	0.95	1.00
Frt		0.850			0.850				0.850			0.850
Flt Protected	0.950			0.950			0.950			0.950		
Satd. Flow (prot)	1662	1488	0	1441	1394	0	1478	3087	1369	1465	3144	1146
Flt Permitted	0.745			0.711			0.259			0.398		
Satd. Flow (perm)	1304	1488	0	1078	1394	0	403	3087	1369	614	3144	1146
Right Turn on Red			Yes			Yes			Yes			Yes
Satd. Flow (RTOR)		144			293				38			144
Link Speed (k/h)		50			50			70			70	
Link Distance (m)		261.3			186.8			133.3			189.1	
Travel Time (s)		18.8			13.4			6.9			9.7	
Peak Hour Factor	1.00	1.00	1.00	1.00	1.00	1.00	1.00	1.00	1.00	1.00	1.00	1.00
Heavy Vehicles (%)	4%	2%	4%	20%	2%	11%	17%	12%	13%	18%	10%	35%
Adj. Flow (vph)	187	0	70	10	0	19	35	629	8	17	955	144
Shared Lane Traffic (%)												
Lane Group Flow (vph)	187	70	0	10	19	0	35	629	8	17	955	144
Enter Blocked Intersection	No	No	No	No	No	No	No	No	No	No	No	No
Lane Alignment	Left	Left	Right	Left	Left	Right	Left	Left	Right	Left	Left	Right
Median Width(m)		3.7			3.7			3.7			3.7	
Link Offset(m)		0.0			0.0			0.0			0.0	
Crosswalk Width(m)		4.9			4.9			4.9			4.9	
Two way Left Turn Lane								Yes			Yes	
Headway Factor	1.06	1.06	1.06	1.06	1.06	1.06	1.06	1.06	1.06	1.06	1.06	1.06
Turning Speed (k/h)	24		14	24		14	24		14	24		14
Turn Type	Perm	NA		Perm	NA		Perm	NA	Perm	Perm	NA	Perm
Protected Phases		4			8			2			6	
Permitted Phases	4			8			2		2	6		6
Minimum Split (s)	29.3	29.3		29.3	29.3		32.9	32.9	32.9	32.9	32.9	32.9
Total Split (s)	30.0	30.0		30.0	30.0		65.0	65.0	65.0	65.0	65.0	65.0
Total Split (%)	31.6%	31.6%		31.6%	31.6%		68.4%	68.4%	68.4%	68.4%	68.4%	68.4%
Maximum Green (s)	23.7	23.7		23.7	23.7		59.1	59.1	59.1	59.1	59.1	59.1
Yellow Time (s)	3.3	3.3		3.3	3.3		4.2	4.2	4.2	4.2	4.2	4.2
All-Red Time (s)	3.0	3.0		3.0	3.0		1.7	1.7	1.7	1.7	1.7	1.7
Lost Time Adjust (s)	0.0	0.0		0.0	0.0		0.0	0.0	0.0	0.0	0.0	0.0
Total Lost Time (s)	6.3	6.3		6.3	6.3		5.9	5.9	5.9	5.9	5.9	5.9
Lead/Lag												
Lead-Lag Optimize?												
Walk Time (s)	7.0	7.0		7.0	7.0		7.0	7.0	7.0	7.0	7.0	7.0
Flash Dont Walk (s)	16.0	16.0		16.0	16.0		20.0	20.0	20.0	20.0	20.0	20.0
Pedestrian Calls (#/hr)	0	0		0	0		0	0	0	0	0	0
Act Effct Green (s)	23.7	23.7		23.7	23.7		59.1	59.1	59.1	59.1	59.1	59.1
Actuated g/C Ratio	0.25	0.25		0.25	0.25		0.62	0.62	0.62	0.62	0.62	0.62

Lanes, Volumes, Timings
1: Hawthorne Road & Ages Drive

2026 PM Future Total

Lane Group	EBL	EBT	EBR	WBL	WBT	WBR	NBL	NBT	NBR	SBL	SBT	SBR
v/c Ratio	0.58	0.15		0.04	0.03		0.14	0.33	0.01	0.04	0.49	0.19
Control Delay	39.4	0.6		27.7	0.1		9.1	9.1	0.0	7.4	10.8	1.9
Queue Delay	0.0	0.0		0.0	0.0		0.0	0.0	0.0	0.0	0.0	0.0
Total Delay	39.4	0.6		27.7	0.1		9.1	9.1	0.0	7.4	10.8	1.9
LOS	D	A		C	A		A	A	A	A	B	A
Approach Delay		28.8			9.6			9.0			9.6	
Approach LOS		C			A			A			A	

Intersection Summary











Area Type:	Other
Cycle Length:	95
Actuated Cycle Length:	95
Offset:	48 (51%), Referenced to phase 2:NBTL, Start of Green
Natural Cycle:	65
Control Type:	Pretimed
Maximum v/c Ratio:	0.58
Intersection Signal Delay:	11.8
Intersection LOS:	B
Intersection Capacity Utilization	58.5%
ICU Level of Service	B
Analysis Period (min)	15

Splits and Phases: 1: Hawthorne Road & Ages Drive















Lanes, Volumes, Timings
2: Hawthorne Road & Site Access

2026 PM Future Total

						
Lane Group	WBL	WBR	NBT	NBR	SBL	SBT
Lane Configurations						
Traffic Volume (vph)	5	12	660	5	11	1024
Future Volume (vph)	5	12	660	5	11	1024
Ideal Flow (vphpl)	1900	1900	1900	1900	1900	1900
Storage Length (m)	0.0	0.0		0.0	20.0	
Storage Lanes	1	0		0	1	
Taper Length (m)	2.5				10.0	
Lane Util. Factor	1.00	1.00	0.95	0.95	1.00	0.95
Frt	0.905		0.999			
Flt Protected	0.986				0.950	
Satd. Flow (prot)	1539	0	3256	0	1659	3318
Flt Permitted	0.986				0.950	
Satd. Flow (perm)	1539	0	3256	0	1659	3318
Link Speed (k/h)	50		70			70
Link Distance (m)	106.8		135.2			133.3
Travel Time (s)	7.7		7.0			6.9
Peak Hour Factor	1.00	1.00	1.00	1.00	1.00	1.00
Heavy Vehicles (%)	10%	12%	12%	12%	10%	10%
Adj. Flow (vph)	5	12	660	5	11	1024
Shared Lane Traffic (%)						
Lane Group Flow (vph)	17	0	665	0	11	1024
Enter Blocked Intersection	No	No	No	No	No	No
Lane Alignment	Left	Right	Left	Right	Left	Left
Median Width(m)	3.7		3.7			3.7
Link Offset(m)	0.0		0.0			0.0
Crosswalk Width(m)	1.6		1.6			1.6
Two way Left Turn Lane			Yes			Yes
Headway Factor	0.99	0.99	0.99	0.99	0.99	0.99
Turning Speed (k/h)	24	14		14	24	
Sign Control	Stop		Free			Free
Intersection Summary						
Area Type:	Other					
Control Type:	Unsignalized					
Intersection Capacity Utilization	38.3%			ICU Level of Service A		
Analysis Period (min)	15					

HCM Unsignalized Intersection Capacity Analysis
2: Hawthorne Road & Site Access

2026 PM Future Total

						
Movement	WBL	WBR	NBT	NBR	SBL	SBT
Lane Configurations			 		 	 
Traffic Volume (veh/h)	5	12	660	5	11	1024
Future Volume (Veh/h)	5	12	660	5	11	1024
Sign Control	Stop		Free		Free	
Grade	0%		0%		0%	
Peak Hour Factor	1.00	1.00	1.00	1.00	1.00	1.00
Hourly flow rate (vph)	5	12	660	5	11	1024
Pedestrians						
Lane Width (m)						
Walking Speed (m/s)						
Percent Blockage						
Right turn flare (veh)						
Median type			TWLTL		TWLTL	
Median storage veh)			2		2	
Upstream signal (m)			133			
pX, platoon unblocked	0.84					
vC, conflicting volume	1196	332	665			
vC1, stage 1 conf vol	662					
vC2, stage 2 conf vol	534					
vCu, unblocked vol	859	332	665			
tC, single (s)	7.0	7.1	4.3			
tC, 2 stage (s)	6.0					
tF (s)	3.6	3.4	2.3			
p0 queue free %	99	98	99			
cM capacity (veh/h)	419	635	868			
Direction, Lane #	WB 1	NB 1	NB 2	SB 1	SB 2	SB 3
Volume Total	17	440	225	11	512	512
Volume Left	5	0	0	11	0	0
Volume Right	12	0	5	0	0	0
cSH	551	1700	1700	868	1700	1700
Volume to Capacity	0.03	0.26	0.13	0.01	0.30	0.30
Queue Length 95th (m)	0.7	0.0	0.0	0.3	0.0	0.0
Control Delay (s)	11.7	0.0	0.0	9.2	0.0	0.0
Lane LOS	B			A		
Approach Delay (s)	11.7	0.0	0.1			
Approach LOS	B					
Intersection Summary						
Average Delay	0.2					
Intersection Capacity Utilization	38.3%		ICU Level of Service			A
Analysis Period (min)	15					

Intersection: 1: Hawthorne Road & Ages Drive

Movement	EB	EB	WB	WB	NB	NB	NB	NB	SB	SB	SB	SB
Directions Served	L	TR	L	TR	L	T	T	R	L	T	T	R
Maximum Queue (m)	44.1	14.3	8.2	11.6	21.6	50.4	33.9	2.4	9.7	62.8	45.9	7.6
Average Queue (m)	28.6	2.0	2.1	3.6	10.4	32.4	15.5	0.3	1.9	41.0	18.6	1.6
95th Queue (m)	44.4	21.7	7.7	11.1	23.0	51.5	34.4	2.6	8.7	59.6	36.1	10.0
Link Distance (m)		246.6		169.3		117.6	117.6			176.6	176.6	
Upstream Blk Time (%)												
Queuing Penalty (veh)												
Storage Bay Dist (m)	40.0		30.0		50.0			45.0	50.0			90.0
Storage Blk Time (%)	2						1	0		2		
Queuing Penalty (veh)	1						0	0		0		

Intersection: 2: Hawthorne Road & Site Access

Movement	WB	SB
Directions Served	LR	L
Maximum Queue (m)	13.2	5.0
Average Queue (m)	3.5	0.7
95th Queue (m)	11.9	4.6
Link Distance (m)	95.4	
Upstream Blk Time (%)		
Queuing Penalty (veh)		
Storage Bay Dist (m)	20.0	
Storage Blk Time (%)		
Queuing Penalty (veh)		

Network Summary

Network wide Queuing Penalty: 2

FIGURES

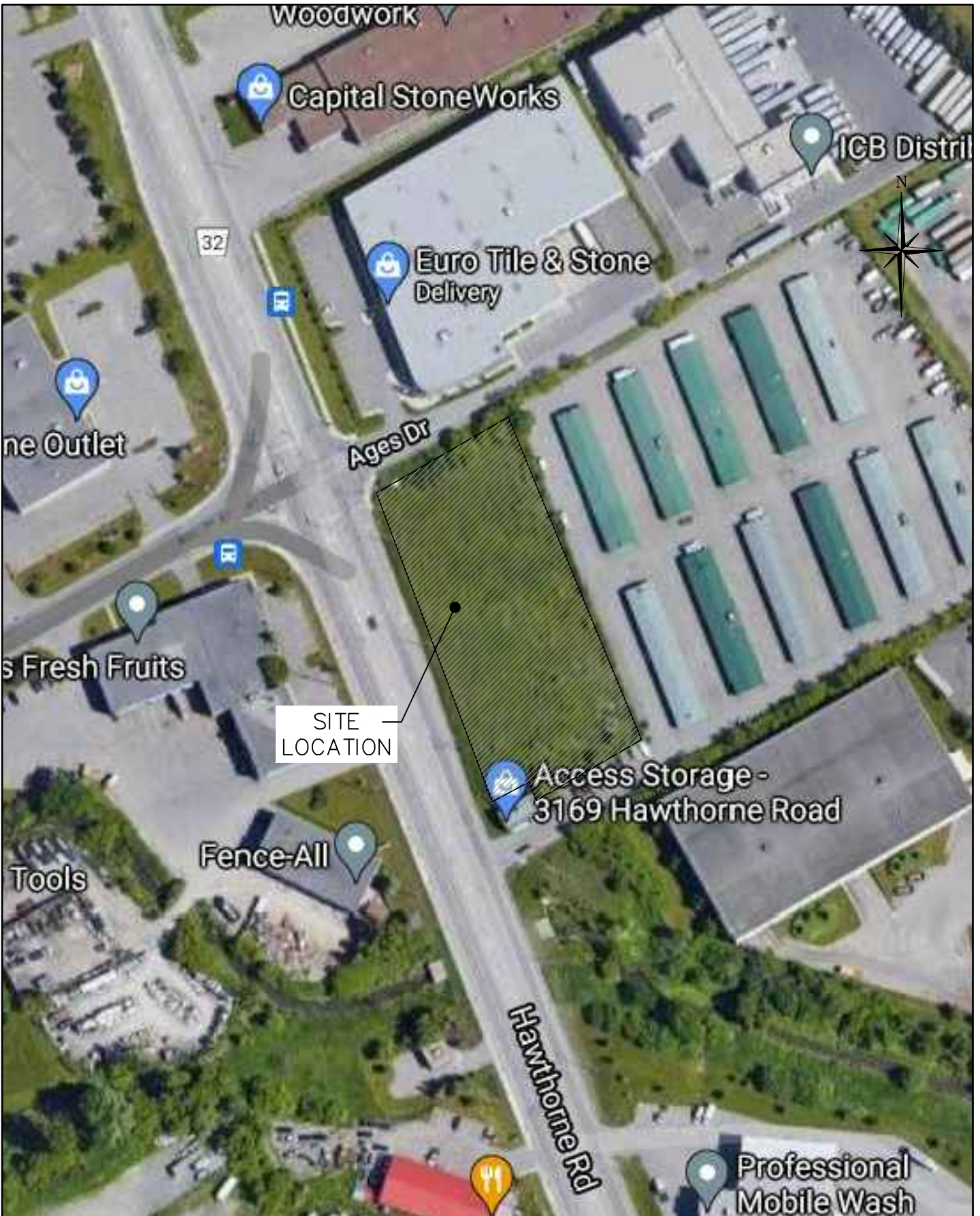

Legend	
	= SUBJECT LANDS

Project	3149 HAWTHORNE RD CITY OF OTTAWA		
Drawing	SITE LOCATION		

 CROZIER CONSULTING ENGINEERS		THE HARBOUREDGE BUILDING, 40 HURON STREET, SUITE 301, COLLINGWOOD, ON L9Y 4R3 705 446-3510 T 705 446-3520 F WWW.CROZIER.CA INFO@CROZIER.CA	
Drawn By	J.P.	Design By	A.H.
Scale	N.T.S.	Date	09/23/2021
Check By	A.H.	Project	2112-6007
			Drawing
			FIG 01

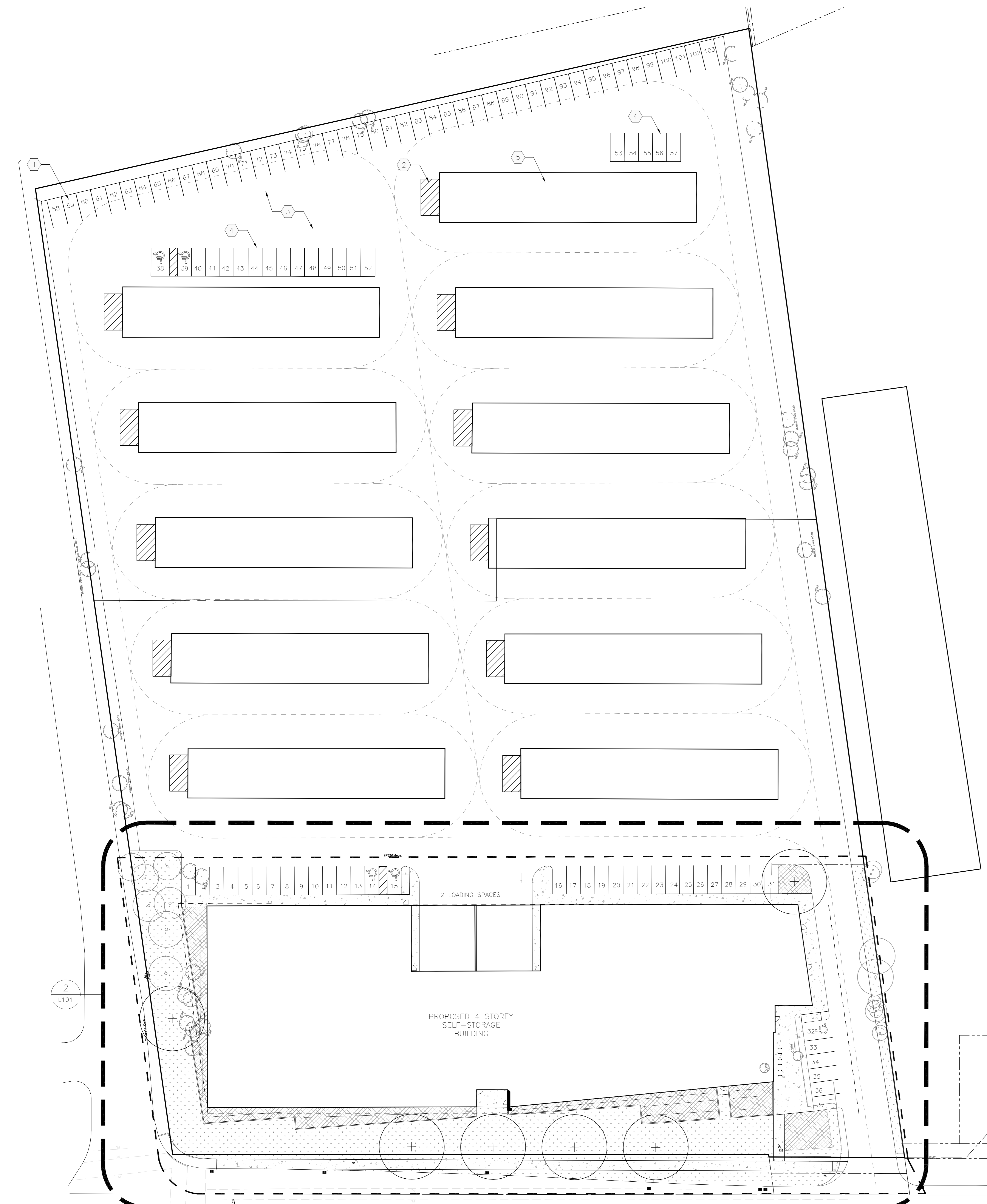

- LEGEND:**
- TOPSOIL AND SOD
 - PLANT BED
 - CONCRETE SIDEWALK
 - PROPERTY LINE
 - APPROXIMATE AREA OF WORK
 - EXISTING CURB
 - NEW CURB
 - ACCESSIBLE PARKING STALL
 - PROPOSED DECIDUOUS TREE
 - EXISTING TREE TO REMAIN. TREES TO REMAIN ARE TO BE PROTECTED TO CITY OF OTTAWA STANDARDS
 - EXISTING TREE TO BE REMOVED

- KEYNOTES:**
1. PROPOSED LOADING AREA (11)
 2. EXISTING PARKING STALLS (46)
 3. EXISTING ASPHALT SURFACE
 4. PROPOSED PARKING STALLS (20, INCLUDING 1 TYPE A & 1 TYPE B ACCESSIBLE STALLS)
 5. EXISTING 1 STOREY CONCRETE BLOCK STORAGE BUILDINGS

- LAYOUT NOTES:**
1. CONTRACTOR TO CONFIRM ALL DIMENSIONS AND REPORT ANY DISCREPANCIES TO CONTRACTOR ADMINISTRATOR PRIOR TO CONSTRUCTION
 2. LAYOUT TO BE APPROVED BY CONTRACT ADMINISTRATOR PRIOR TO ANY CONSTRUCTION OR REMOVALS
 3. ALL DIMENSIONS ARE IN METRIC UNLESS OTHERWISE NOTED
 4. CONTRACTOR IS RESPONSIBLE FOR ALL EXCAVATIONS, REMOVALS, DISPOSALS AND ROUGH GRADING AS REQUIRED TO CONSTRUCTION ALL WORKS AS SHOWN ON ALL PLANS, DETAILS AND SPECIFICATIONS
 5. LOCATION OF ALL UTILITIES SHOWN FOR ILLUSTRATION ONLY. CONTRACTOR MUST CONTRACT ALL UTILITIES REGARDING RULES FOR WORKING IN THE AREA OF THE UTILITIES PRIOR TO COMMENCEMENT OF ANY WORK. CONTRACTOR MUST CONFIRM LOCATION OF ALL UTILITIES PRIOR TO CONSTRUCTION
 6. ALL EXISTING ROADS, SIDEWALKS, CURBS, FENCING, PAVING, SODDED AREAS, AND APPROACHES, ETC. TO REMAIN TO BE PROTECTED DURING CONSTRUCTION TO CONTRACT ADMINISTRATOR'S APPROVAL AT THE CONTRACTORS OWN COSTS.
 7. ALL EXISTING TREES, SHRUB BEDS, MULCH BEDS, AND SOD TO REMAIN TO BE PROTECTED DURING CONSTRUCTION. AREAS DAMAGED DURING CONSTRUCTION TO BE REPAIRED TO CONTRACT ADMINISTRATOR'S APPROVAL AT THE CONTRACTORS OWN COST.
 8. USE SPECIFIED BACKFILL IN ALL TRENCHES RUNNING BELOW ALL STRUCTURES, PAVING, WALKWAYS, ETC.
 9. ALL HOLES AND LOW AREAS TO DESIGN SUBGRADE WITH COMPACTED FILL (SUITABLE TO SURFACE FINISH). FOR SODDED/PLANTED AREAS USE COMPACTED CLEAN EARTH FILL SUITABLE FOR PLANT GROWTH. FOR PAVED AREAS USE COMPACTED GRANULAR BASE.
 10. ALL TREES WITHIN OR IMMEDIATELY ADJACENT TO AREA OF WORK TO BE PROTECTED TO CITY OF OTTAWA TREE PROTECTION STANDARDS.

ZONING STATISTICS

SITE INFORMATION:
LEGAL DESCRIPTION:
Lot 2, Concession 6 (Rideau Front),
Geographic Township of Gloucester,
City of Ottawa

EASEMENTS:
Inst. OC1310363 Part 3, Plan 4R-25574
Inst. N679846, Part 1, Plan 4R-9620
Inst. LT1170415, Part 15, Plan 4R-14092
Inst. OC201490, By-law 2003-162
Inst. N430098 (LT605535)

MUNICIPAL ADDRESS: 3169 Hawthorne Road, Ottawa, Ontario

LOT AREA: 7,273.78 m² (Required 2,000 m² min.)

BUILDING GROSS FLOOR AREAS: Existing 4,812.4 m², Proposed 10,854 m²

MAX. BUILDING HEIGHT: 15.84 m (Required 18.0 m max.)

ZONING INFORMATION:
ZONE: Light Industrial Zone (IL)
PROPOSED LOT COVERAGE: 54% (Maximum allowable 65%)
BUILDING SETBACKS:
MIN. FRONT YARD: 8.7 (Required 7.5 m)
MIN. SIDE YARD: 7.8 m (Required 7.5 m)
MIN. REAR YARD: 7.5 (Required 7.5 m)

PARKING REQUIREMENTS:
VEHICULAR PARKING:
1. Light Industrial: 0.8 per 100 m² for first 5,000 m² gross floor area; 0.4 per 100 m² of remaining gross floor area.
1.1. Proposed building = 63.42 spaces
1.2. Existing buildings = 19.25 spaces
1.3. Total site = 83 spaces required
2. Accessible parking required = 2 Type A & 3 Type B
TOTAL PARKING PROVIDED: 103 spaces (including 2 Type A & 3 Type B)

BICYCLE PARKING:
Light Industrial: 1 per 1000 m² of gross floor area = 11 spaces required
TOTAL PARKING PROVIDED: 12 spaces

CONSULTANT - SUB CONSULTANT

CONSULTANT - SUB CONSULTANT

CONSULTANT - SUB CONSULTANT

CONSULTANT - SUB CONSULTANT

SEAL:

CLIENT:

ACCESS PROPERTY DEVELOPMENTS

CLIENT REF. #:

PROJECT:

PROPOSED SELF-STORAGE

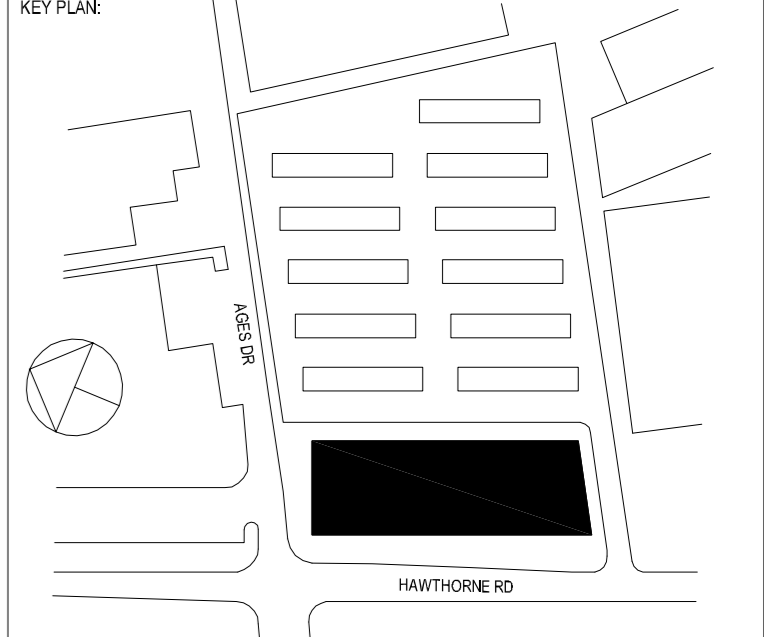

DISCLAIMER: THIS DRAWING AND DESIGN IS COPYRIGHT PROTECTED WHICH SHALL NOT BE REPRODUCED OR REARED WITHOUT WRITTEN PERMISSION BY ARCHITECTURE 49. THE CONTRACTOR SHALL CHECK THE EXISTING UTILITIES AND STREET LOCATIONS AND REPORT ALL UNKNOWNS AND OMISSIONS PRIOR TO CONSTRUCTION WORK. THE DRAWING IS NOT TO BE SCALED.

ISSUED FOR REVISION:

NO.	DATE	DESCRIPTION

NO.	DATE	DESCRIPTION
1	SEPT 13, 2021	ISSUED FOR DEVELOPMENT PERMIT
2		
3		
4		
5		
6		
7		
8		
9		
10		

PROJECT NO: 219-02055-00 DATE: 2021-09-13

ORIGINAL SCALE: As Indicated

DESIGNED BY: JAH

AMT NR: NR

CHECKED BY: JAH

DATE: 2021-09-13

DISCIPLINE: LANDSCAPE ARCHITECTURE

PROPOSED OVERALL SITE PLAN

SHEET NUMBER: **L100**

SHEET # OF

ISSUE: ISSUED FOR DEVELOPMENT PERMIT

DATE OF: 2021 09 13

1 SITE PLAN
L100 1:200

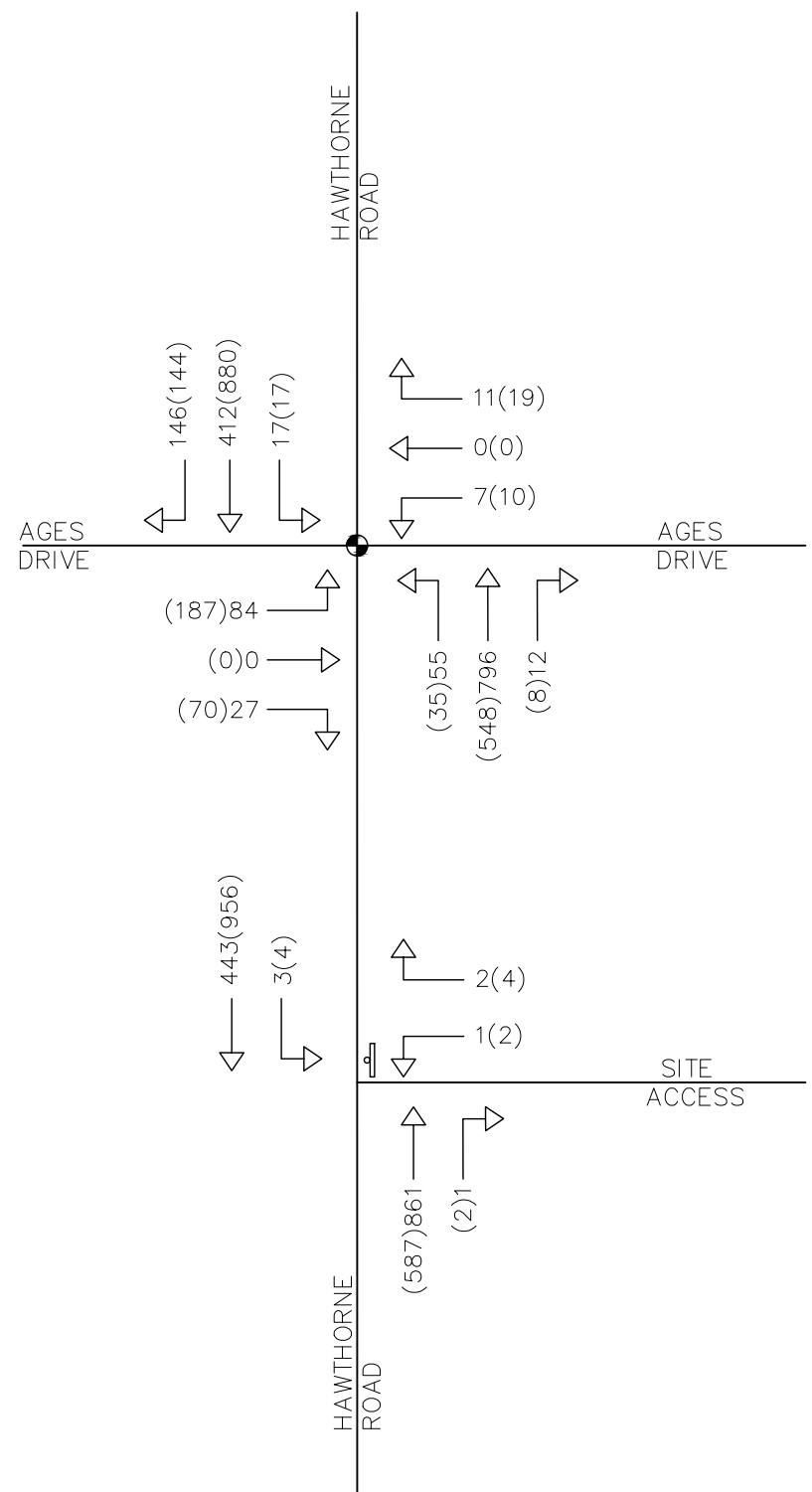
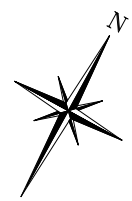

NOTE: THIS FIGURE IS FOR SCHEMATIC PURPOSES ONLY & IS NOT TO BE SCALED.

Legend SIGNAL CONTROL STOP CONTROL xx(yy) WEEKDAY A.M. (WEEKDAY P.M.) PEAK HOUR VOLUMES	Project 3149 HAWTHORNE RD CITY OF OTTAWA	 THE HARBOUREDGE BUILDING, 40 HURON STREET, SUITE 301, COLLINGWOOD, ON L9Y 4R3 705 446-3510 T 705 446-3520 F WWW.CROZIER.CA INFO@CROZIER.CA
	Drawing 2021 EXISTING TRAFFIC VOLUMES	

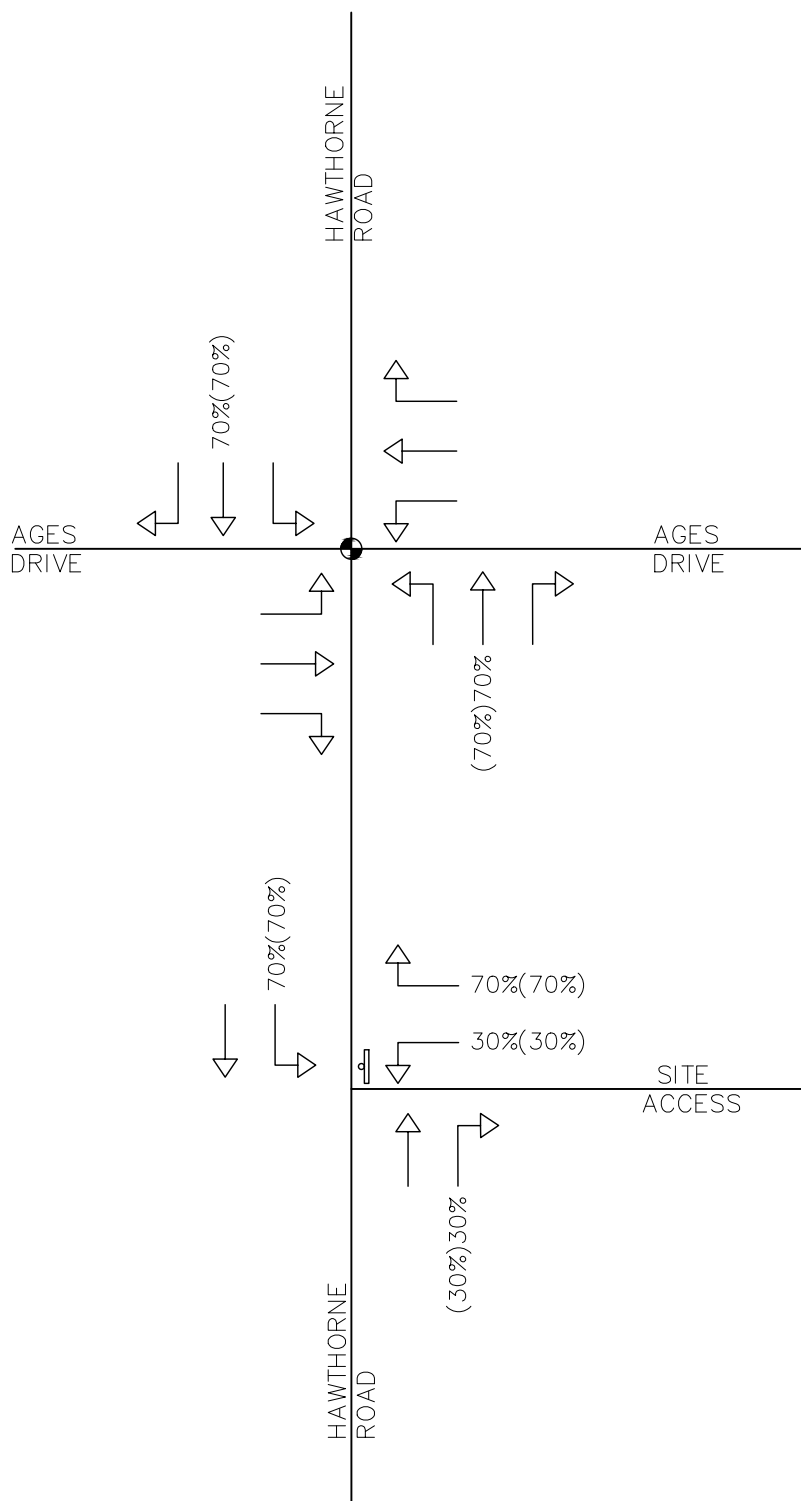
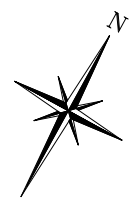

NOTE: THIS FIGURE IS FOR SCHEMATIC PURPOSES ONLY & IS NOT TO BE SCALED.

Legend SIGNAL CONTROL STOP CONTROL WEEKDAY A.M. (WEEKDAY P.M.) PEAK HOUR VOLUMES	Project 3149 HAWTHORNE RD CITY OF OTTAWA	 THE HARBOUREDGE BUILDING, 40 HURON STREET, SUITE 301, COLLINGWOOD, ON L9Y 4R3 705 446-3510 T 705 446-3520 F WWW.CFCROZIER.CA INFO@CFCROZIER.CA
	Drawing SITE GENERATED TRIP DISTRIBUTION	

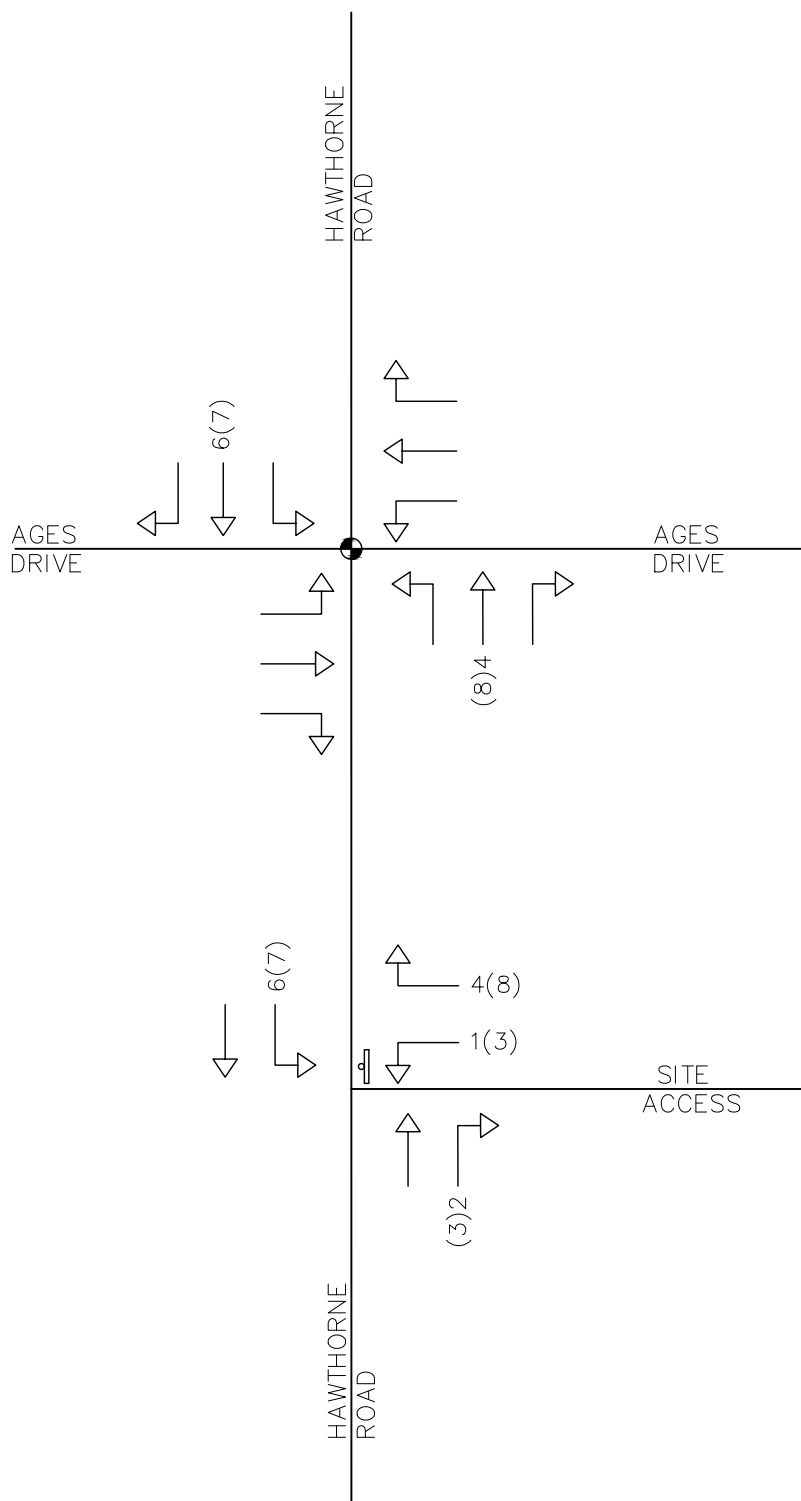
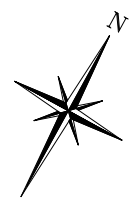

NOTE: THIS FIGURE IS FOR SCHEMATIC PURPOSES ONLY & IS NOT TO BE SCALED.

Legend SIGNAL CONTROL STOP CONTROL XX(Y) WEEKDAY A.M. (WEEKDAY P.M.) PEAK HOUR VOLUMES	Project 3149 HAWTHORNE RD CITY OF OTTAWA	 THE HARBOUREDGE BUILDING, 40 HURON STREET, SUITE 301, COLLINGWOOD, ON L9Y 4R3 705 446-3510 T 705 446-3520 F WWW.CFCROZIER.CA INFO@CFCROZIER.CA
	Drawing SITE GENERATED TRIP ASSIGNMENT	

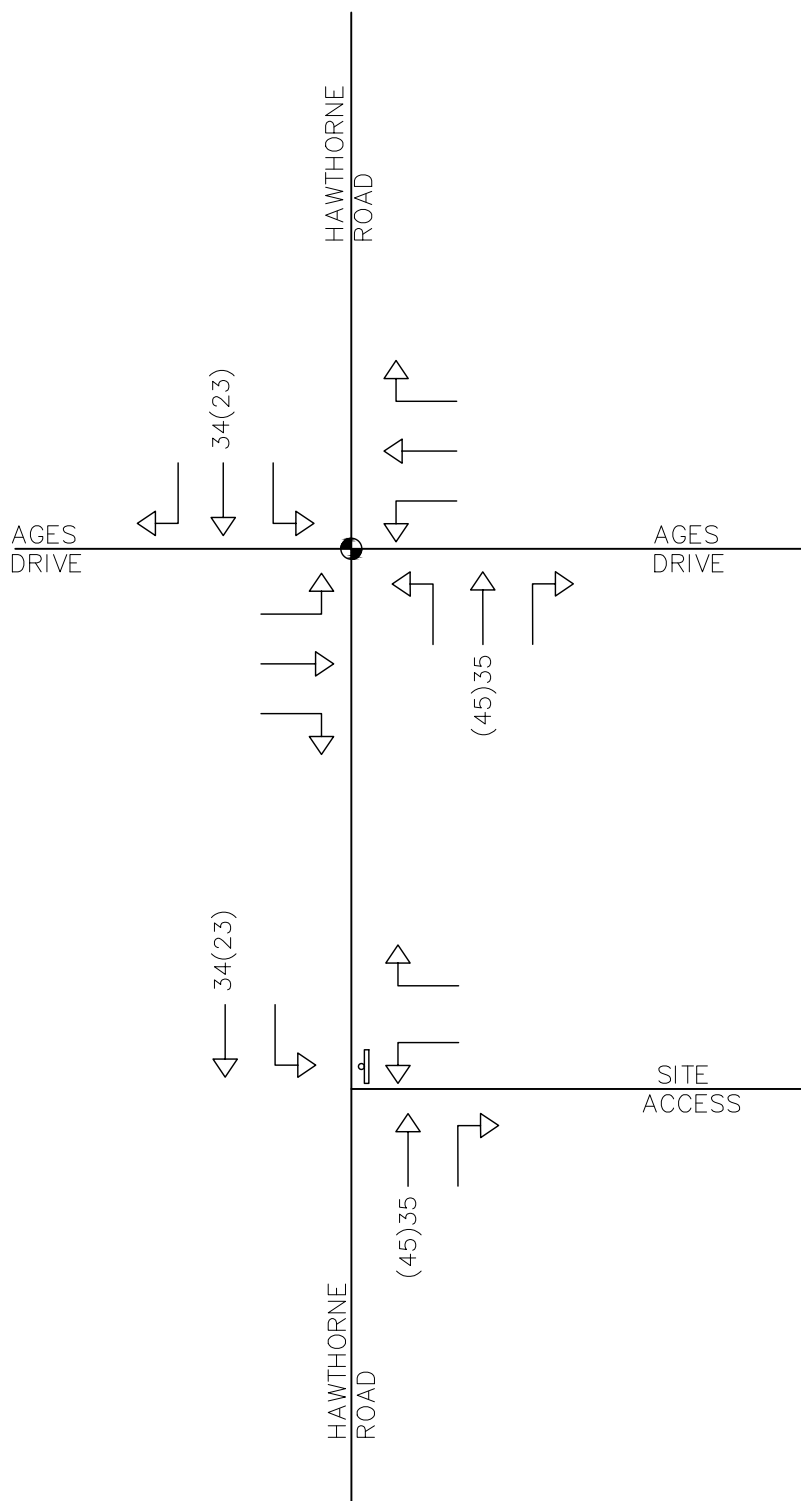
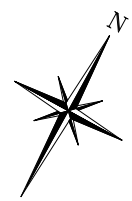

NOTE: THIS FIGURE IS FOR SCHEMATIC PURPOSES ONLY & IS NOT TO BE SCALED.

Legend SIGNAL CONTROL STOP CONTROL xx(yy) WEEKDAY A.M. (WEEKDAY P.M.) PEAK HOUR VOLUMES	Project 3149 HAWTHORNE RD CITY OF OTTAWA	 THE HARBOUREDGE BUILDING, 40 HURON STREET, SUITE 301, COLLINGWOOD, ON L9Y 4R3 705 446-3510 T 705 446-3520 F WWW.CFCROZIER.CA INFO@CFCROZIER.CA
	Drawing BACKGROUND DEVELOPMENTS TRAFFIC	

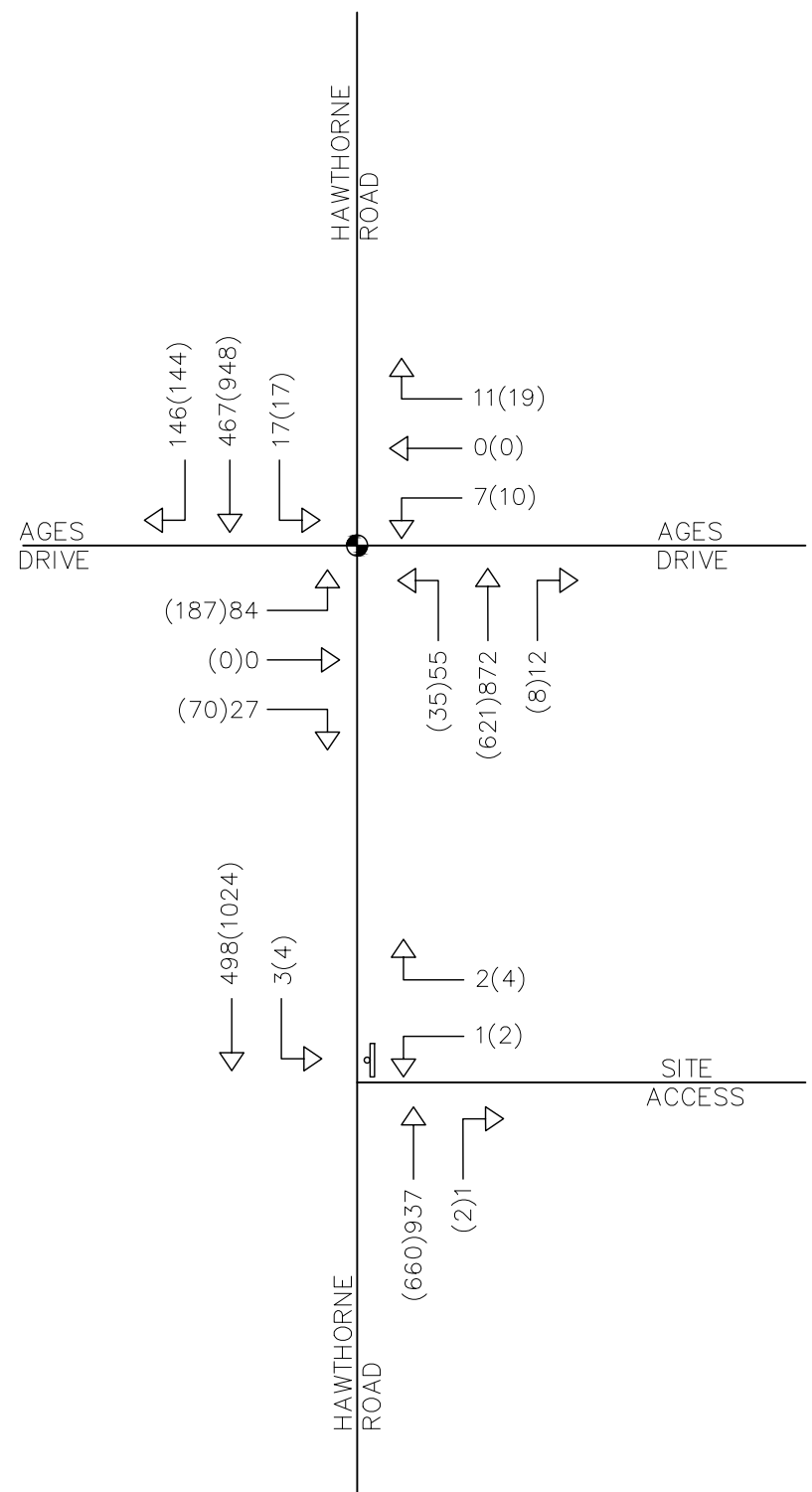
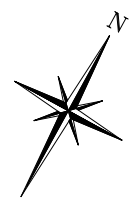

NOTE: THIS FIGURE IS FOR SCHEMATIC PURPOSES ONLY & IS NOT TO BE SCALED.

Legend SIGNAL CONTROL STOP CONTROL xx(yy) WEEKDAY A.M. (WEEKDAY P.M.) PEAK HOUR VOLUMES	Project 3149 HAWTHORNE RD CITY OF OTTAWA	CROZIER CONSULTING ENGINEERS <small>THE HARBOUREDGE BUILDING, 40 HURON STREET, SUITE 301, COLLINGWOOD, ON L9Y 4R3 705 446-3510 T 705 446-3520 F WWW.CROZIER.CA INFO@CROZIER.CA</small>
	Drawing 2026 FUTURE BACKGROUND TRAFFIC	

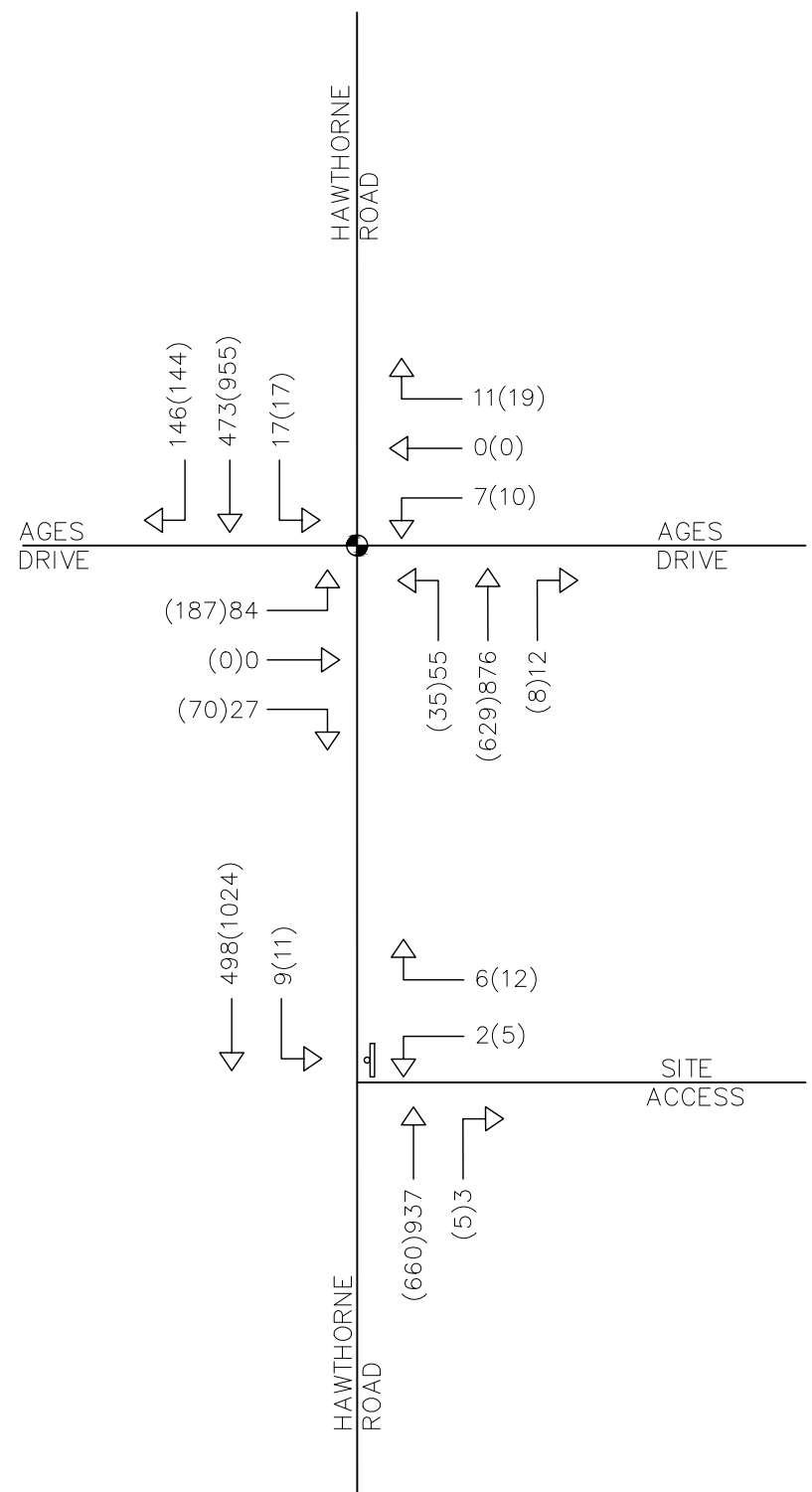
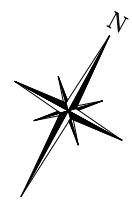

NOTE: THIS FIGURE IS FOR SCHEMATIC PURPOSES ONLY & IS NOT TO BE SCALED.

Legend SIGNAL CONTROL STOP CONTROL xx(yy) WEEKDAY A.M. (WEEKDAY P.M.) PEAK HOUR VOLUMES	Project 3149 HAWTHORNE RD CITY OF OTTAWA	 THE HARBOUREDGE BUILDING, 40 HURON STREET, SUITE 301, COLLINGWOOD, ON L9Y 4R3 705 446-3510 T 705 446-3520 F WWW.CROZIER.CA INFO@CROZIER.CA											
	Drawing 2026 TOTAL TRAFFIC VOLUMES		<table border="1"> <tr> <td>Drawn By</td> <td>J.P./T.D.S.</td> <td>Design By</td> <td>A.H.</td> <td>Project</td> <td>2112-6007</td> </tr> <tr> <td>Scale</td> <td>N.T.S.</td> <td>Date</td> <td>09/23/2021</td> <td>Check By</td> <td>A.H.</td> </tr> </table>	Drawn By	J.P./T.D.S.	Design By	A.H.	Project	2112-6007	Scale	N.T.S.	Date	09/23/2021
Drawn By	J.P./T.D.S.	Design By	A.H.	Project	2112-6007								
Scale	N.T.S.	Date	09/23/2021	Check By	A.H.								